







Portrait of William

*W. Sullivan*

*From a contemporary notice in the possession of*

THE  
JOURNAL

OF THE  
ROYAL AGRICULTURAL SOCIETY  
OF ENGLAND.

---

*Third Series.*

---

VOLUME THE SECOND.

---

PRACTICE WITH SCIENCE

---

LIBRARY  
NEW YORK  
BOTANICAL  
GARDEN

LONDON:  
JOHN MURRAY, ALBEMARLE STREET.  
1891.

.0933  
2nd series  
V. 2

PRINTED BY  
SPOTTISWOODE AND CO., NEW-STREET SQUARE  
LONDON

# CONTENTS OF VOLUME II.

## THIRD SERIES.

1891.

PORTRAIT OF JETHRO TULL . . . . . *Frontispiece*

### Special Articles.

	PAGE
Jethro Tull: his Life, Times, and Teaching . . . . . By EARL CATHCART.	1
Indian Agriculture in its Physical Aspects . . . . . By J. AUGUSTUS VOELCKER, Ph.D., B.A., B.Sc.	41
Acidity in Milk ( <i>Illustrated</i> ) . . . . . By FRANCIS T. BOND, M.D.	56
Farm Poultry . . . . . By W. B. TEGETMEIER, F.Z.S.	67
The Tubercle Bacillus ( <i>Illustrated</i> ) . . . . . By Prof. EDGAR M. CROOKSHANK, M.B.	83
Technical Education in Agriculture . . . . . By W. FREAM, B.Sc., LL.D.	95
Modern Bee-keeping ( <i>Illustrated</i> ) . . . . . By THOMAS B. BLOW, F.L.S.	112
Agriculture and the House of Russell . . . . . By ERNEST CLARKE, Secretary of the Society and Editor of the Journal.	123

Methods of Preventing and Checking the Attacks of Insects and Fungi  
(*Illustrated*). By CHARLES WHITEHEAD, F.L.S., F.G.S. 217

MAR 17 1915

	PAGE
The Survival in Farming . . . . .	257
By WILLIAM E. BEAR.	
The Work of Acidity in Cheese-Making . . . . .	275
By FRANCIS T. BOND, M.D.	
Experiences of the Severe Winter of 1890-91 . . . . .	288
By GILBERT MURRAY.	
The Canker of the Larch ( <i>Illustrated</i> ) . . . . .	299
By J. B. CARRUTHERS, F.L.S.	
Experiences of a Scotsman on the Essex Clays . . . . .	311
By PRIMROSE McCONNELL, B.Sc.	
Sugar-Beet Cultivation in Austria ( <i>Illustrated</i> ) . . . . .	325
By ERNEST CLARKE.	
The Doncaster Meeting ( <i>With a Plan</i> ) . . . . .	441
By W. FREAM, B.Sc., LL.D., Official Reporter.	
The Trials of Threshing Machines at Doncaster ( <i>Illustrated</i> ) . . . . .	482
By W. ANDERSON, C.E., D.C.L., F.R.S.	
The Trials of Cream Separators at Doncaster ( <i>Illustrated</i> ) [with a Note on the Efficiency of Separation] . . . . .	497
By J. AUGUSTUS VOELCKER, Ph.D., B.A., B.Sc.	
Miscellaneous Implements exhibited at Doncaster ( <i>Illustrated</i> ) . . . . .	521
By W. J. MALDEN.	
The Farm Prize Competition of 1891 ( <i>Illustrated</i> ) . . . . .	547
By W. C. BROWN.	
The Sources of the Nitrogen of our Leguminous Crops . . . . .	657
By Sir JOHN BENNET LAWES, Bart., LL.D., F.R.S., and J. H. GILBERT, LL.D., F.R.S.	
The Nitrifying Ferments of the Soil . . . . .	702
By J. M. H. MUNRO, D.Sc.	
Sale of Corn by Weight . . . . .	717
By R. JASPER MORE, M.P.	
Abortion in Cattle . . . . .	729
By Prof. G. T. BROWN, C.B.	
The Future of Agricultural Competition . . . . .	742
By WILLIAM E. BEAR.	

Profit Sharing in Agriculture . . . . .	771
By ALBERT GREY.	
The Dutch Agricultural Colonies . . . . .	794
By ERNEST CLARKE.	

### Official Reports.

Annual Report for 1890 of the Royal Veterinary College ( <i>Illustrated</i> ). . . . .	146
Further Report of the Education Committee on Technical Education in Agriculture, February 3, 1891 . . . . .	155
Quarterly Report of the Chemical Committee, March 1891 . . . . .	157
Report of the Consulting and Acting Consulting Chemists for the years 1889 and 1890 . . . . .	161
By J. AUGUSTUS VOELCKER, Ph.D., B.A., B.Sc., and E. W. VOELCKER.	
Report of the Consulting Entomologist, March 3, 1891 ( <i>Illustrated</i> ) . . . . .	168
By ELEANOR A. ORMEROD.	
Report of the Council to the Anniversary General Meeting of Governors and Members, May 22, 1891 . . . . .	355
Field Experiments at Woburn in 1889 and 1890 . . . . .	362
By J. AUGUSTUS VOELCKER, Ph.D., B.A., B.Sc.	
Field Experiments conducted in 1889 and 1890 by Local Agricultural Societies . . . . .	379
By J. AUGUSTUS VOELCKER, Ph.D., B.A., B.Sc.	
Reports of the Consulting Entomologist, dated May 5, 1891, and June 2, 1891 ( <i>Illustrated</i> ) . . . . .	389
By ELEANOR A. ORMEROD.	
Quarterly Report of the Chemical Committee, June, 1891 . . . . .	398
Report of the Education Committee on the Results of the Senior Examination, 1891 . . . . .	407
The Comparative Feeding Values of Decorticated and Undecorticated Cotton-cake . . . . .	585
By J. AUGUSTUS VOELCKER, Ph.D., B.A., B.Sc.	

	PAGE
Report of the Consulting Entomologist, July 28, 1891 . . . . .	595
By ELEANOR A. ORMEROD.	
The Diamond-back Moth ( <i>Illustrated</i> ) . . . . .	596
By ELEANOR A. ORMEROD.	
Quarterly Report of the Chemical Committee, July, 1891 . . . . .	631
Report of the Council to the Half-Yearly General Meeting of Governors and Members, December 10, 1891 . . . . .	805
Quarterly Report of the Chemical Committee, December, 1891 . . . . .	814
Report of the Education Committee on the Results of the Junior Examination of November, 1891 . . . . .	823
Report on the Experiments with <i>Bouillie Bordelaise</i> ( <i>Illustrated</i> ) . . . . .	828
Annual Report for 1891 of the Consulting Chemist . . . . .	835
By J. AUGUSTUS VOELCKER, Ph.D., B.A., B.Sc.	
Annual Report for 1891 of the Consulting Botanist . . . . .	845
By WILLIAM CARRUTHERS, F.R.S.	
Annual Report for 1891 of the Honorary Consulting Entomologist ( <i>Illustrated</i> ). By ELEANOR A. ORMEROD . . . . .	849
Report of the Judges on the Milking Machine exhibited at Doncaster . . . . .	854
By R. NEVILLE GRENVILLE and THOMAS RIGBY.	

---

## Notes, Communications, and Reviews.

The Cost of Wheat Growing. By JAMES A. CAIRD . . . . .	172
Pink Eye among Horses in 1890. By Prof. J. WORTLEY ANE . . . . .	175
Market Rights and Tolls. By CECIL M. CHAPMAN . . . . .	179
The Quality of Barley . . . . .	188
Permanent and Temporary Pastures . . . . .	192
The Weather of 1890 . . . . .	193
The Great Frost of 1890-91 ( <i>Illustrated</i> ) . . . . .	196
Recent Agricultural Inventions . . . . .	200
The Price of Wheat in 1890 . . . . .	204
Statistics affecting British Agricultural Interests . . . . .	205



Harvesting the Seed of Root Crops. By W. J. MALDEN . . . . .	419
Farmers' Accounts. By WESTLEY RICHARDS . . . . .	422
Some Remarkable Features in the Winter of 1890-91 . . . . .	425
Lopping and Topping Trees. By S. B. L. DRUCE . . . . .	429
Hay Harvest Forecasts, 1890 . . . . .	430
Some Relations of Biology to Agriculture. By W. FREAM, B.Sc. LL.D.	431
Recent Agricultural Inventions . . . . .	437
The Relations of the Diseases of Animals to those of Man . . . . .	634
By G. SIMS WOODHEAD, M.D.	
The Agricultural Holdings Act. By S. B. L. DRUCE . . . . .	640
The Canker of the Larch. By ROBERT ANDERSON . . . . .	643
American Farm Crops. By R. HENRY REW . . . . .	644
The Smut of Onions. By J. W. LEATHER, Ph.D. . . . .	647
Recent Agricultural Inventions . . . . .	650
Statistics affecting British Agricultural Interests . . . . .	655
The Sampling of Manures and Feeding Stuffs . . . . .	858
By J. AUGUSTUS VOELCKER, Ph.D., B.A., B.Sc.	
Experiments in the Planting of Potatoes. By GEORGE MALDEN . . . . .	864
Farming without Live Stock. By W. FREAM, B.Sc., LL.D. . . . .	870
The Late Duke of Devonshire. By ERNEST CLARKE. . . . .	875
Recent Agricultural Inventions . . . . .	879
Statistics affecting British Agricultural Interests . . . . .	883

APPENDIX.

List of Council of Royal Agricultural Society of England, 1891 . . . . .	i
Standing Committees for 1891 . . . . .	iii
Chief Officials of the Society . . . . .	v
Geographical Distribution of Members and Council . . . . .	v
List of Governors of the Society . . . . .	vii
List of Honorary Members of the Society . . . . .	xi
Summary of Members on the Register at December 31, 1890 . . . . .	xi

	PAGE
Report of the Auditors, March 2, 1891 . . . . .	xii
Balance Sheet for 1890, with appended Statements of General and Country Meeting Receipts and Expenditure . . . . .	xiv
Table showing number of Governors and Members in each year from the Establishment of the Society . . . . .	xxii
Proceedings of the Council, February 4, 1891 . . . . .	xxiii
Proceedings of the Council, March 4, 1891 . . . . .	xxxix
Principal Additions to the Library during the year 1890 . . . . .	xliv
Proceedings of the Council, April 8, 1891 . . . . .	xlix
Proceedings of the Council, May 6, 1891 . . . . .	lvii
Proceedings of the Council, June 3, 1891 . . . . .	lxv
Proceedings at the General Meeting, May 22, 1891 . . . . .	lxxv
Proceedings of the Council, June 23, 1891 . . . . .	lxxvii
Proceedings of the Council, July 29, 1891 . . . . .	lxxxii
Proceedings at the General Meeting, June 23, 1891 . . . . .	xciii
Officials and Judges at the Doncaster Meeting . . . . .	xcvii
Award of Prizes at the Doncaster Meeting . . . . .	c
Proceedings of the Council, November 4, 1891 . . . . .	clxv
Proceedings of the Council, December 9, 1891 . . . . .	clxxvi
Proceedings at the General Meeting, December 10, 1891 . . . . .	clxxxiii
Prizes offered in connection with the Warwick Meeting, June, 1892	clxxxvii

## ERRATUM.

On page 495, Part III., for "lighter," read, "lighter framed."

## DIRECTIONS TO THE BINDER.

All the pages of text (1 to 884) should come first in the bound volume; and the pages of Appendix (i to exc) at the end.

*Text* :—Pages 1 to 216 of the text are included in Part I. (March 31, 1891); pages 217 to 440 in Part II. (June 30, 1891); pages 441 to 656 in Part III. (Sept. 30, 1891); and pages 657 to 884 in Part IV. (December 31, 1891).

*Appendix* : Pages i to lviii are included in Part I.; xlix to lxxvi in Part II.; lxxviii to clxiv in Part III.; and clxv to exc in Part IV.

Cloth cases for binding can be obtained of Messrs. Spottiswoode & Co., price 1s. 3d.

JOURNAL  
OF THE  
ROYAL AGRICULTURAL SOCIETY  
OF ENGLAND.

---

JETHRO TULL: HIS LIFE, TIMES  
AND TEACHING.

MEN, like pictures, may be placed in an obscure light; but, that being so, it is for the truth-seeking biographer a congenial duty to endeavour honestly to lift an originally excellent and worthy biographical portrait into the light of the present day, to free it from the dust of ages and the cobwebs of ungrateful neglect, to raise it up on high, and crying aloud to exclaim, "Behold the true portrait of a patriotic man worthy of abiding fame, who, judged by the standard of his own age, was a giant indeed, that, by taking giant steps far away in advance, conduced perhaps more than any man to the advancement of British agriculture, and thereby benefited his fellow countrymen, and materially added to the stature of his country."

The world forgets so much and remembers so little. Until the other day Tull's grave was undiscovered, and even now no storied urn, no monumental brass, marks the modest grave of a man so worthy of honour. Yet more remarkable still is the fact that, although the student reads the name of Tull "writ large" on the face of every arable field in Great Britain, and over all the world wherever British agriculture is known and prevails, the ordinary reader—and such is fame!—will say to himself, "Who was this man? when did he live? and what did he do?"

Jethro Tull in the early years of the reign of King George the Second wrote a book, entitled *The Horse Hoeing Husbandry*,

or a *Treatise on the Principles of Tillage and Vegetation, wherein is taught a Method of introducing a sort of Vineyard Culture into the Cornfields, in order to increase their Product and diminish the Common Expense.* The principles formulated in this famous book, ultimately—but step by step and by very slow degrees—revolutionised British agriculture. Tull invented the drill; but our admiration and gratitude are chiefly due to him because of the reasons which he gave us for the utility of his undoubted invention of that now universally employed implement.

Throughout one hundred and fifty years of neglect and comparative obscurity the true light and tradition have been handed down undimmed and undiminished by the Levitic hands of a real agricultural succession of scholars and authors. They knew full well that to study Tull's book is to strip many an early agricultural philosopher of his borrowed plumes. Twenty-four years after Tull's death it was said by the personal friend and neighbour<sup>1</sup> who painted his original biographical portrait, that Tull was the first Englishman, perhaps the first writer ancient or modern, who has attempted with any tolerable degree of success to reduce the art of agriculture to certain and uniform principles; and it must be acknowledged that he has done more towards establishing a rational and practical method of husbandry than all the writers who have gone before him. Again, thirty years after, a famous pilgrimage was made by Arthur Young. "I visited," said the well-known writer, "Prosperous Farm, which the celebrated Jethro Tull has made for ever famous by a work which will unquestionably carry his name to the latest posterity."

Twenty-seven years again pass and an agricultural author,<sup>2</sup> whose *Rural Rides* and other writings are, in the literature of our country, models of nervous English, visited Prosperous. He has written thus:—

"I was born and bred amongst affairs of gardening and farming, and I was well read, but till I read Tull I knew nothing of principles. Here are, in fact, all the whole code of the principles of vegetation and of general application, whether in the cornfields, the pastures, the gardens, the coppices, the woods, and the forests."

And again he says with characteristic homespun eloquence:—"Just indignation is excited when we remember that Tull's ideas have been pillaged by a whole gang and succession of

<sup>1</sup> D. Y., of Hungerford, in the *Gent. Mag.* of 1764. This able gentleman probably belonged to the Yorke family; the surname constantly occurs in the Parish Registers, but diligent search so far has failed to connect the surname with a Christian name of which the initial is D.

<sup>2</sup> Cobbett.

‘Drill Husbandry’ banditti, who in their turn have so plundered one another, until no one of them, perhaps, could guess who was the original thief.”

Yet another writer, author of the two gems of agricultural literature, brings this true agricultural succession down to our own day and generation. His charm of manner, his many accomplishments, have left a deep and lasting impression in the hearts of some still living friends and colleagues. The author of the *History of Agriculture*<sup>1</sup> and of *Talpa* refers to the sadly interesting life of Tull, and goes on to say that “he was the greatest individual improver that agriculture ever knew. . . . There was, before the dawn of chemical and geological science, ingenuity and originality of thought groping in utter darkness of guesswork and speculation. Tull best answers the question, What can chemistry do for agriculture? So far as he was unknowingly in accord with chemical truth he was right; as he deserted it he was wrong. Deep and perfect pulverisation is the great secret of vegetable nutrition: in regard to that beautiful mystery, Tull distinguished the form without seeing the face.”

The spirit of individual enterprise was incarnate in Tull. His life exhibits all the conditions of a great and original discoverer—there is much in his history to remind the student of James Watt. By his original idea Tull was pursued rather than pursuing; his very errors and excesses are nearly as instructive as his successful experiments. In him, there was a rare combination of two faculties, perception and reflection; the flash of his common-sense genius was beautiful in its simplicity.

Great and prolific ideas are usually simple. With him the inventive faculty was a passion, an instinct; an observer, a finder-out, his eyes were as spy-glasses, observing soil, culture, vegetable productions, methods, implements, everything; he had the quick perception which sees and foresees the effects of various combinations, as well as insight, dexterity, patience, perseverance, faith, and, after a fall, the dauntless determination that imparts the conviction, “I shall rise again.” Tull’s practical nature is well demonstrated in his own words: “Writing and ploughing are two different talents; and he that writes well must have spent in his study that time which is necessary to be spent in the fields by him who will be master of the art of cultivating them.”

Tull was also an excellent mechanic, a musician, and a classical scholar of no inconsiderable attainments. He was, however, unhappily, a valetudinarian; his whole life was one long struggle with chronic disease. But these fearfully depressing influences

---

<sup>1</sup> Wren-Hoskyns.

were overborne by that never-resting energy of spirit which was his chief characteristic. Tull's own words are very sad; of his book he says, "The whole was written in pains of the stone and other diseases as incurable and almost as cruel." Tull was not without a sense of humour. For example, he rechristens an adverse book, *The Practical Husbandman*; he says it should have for title *The Cockney Husbandman*, who never practised agriculture out of the sound of Bow bells. By way of illustration he cites the case of an old woman of good eyes and strong imagination, who could see a needle upon a barn, whilst she could not see the barn itself. And, again, a gentleman who consults with his bailiff about entering upon a new scheme of husbandry is likely to have the same encouragement as a Papist, having a mind to turn Protestant, would have by asking the opinion of his confessor.

Partly by nature, chiefly no doubt from bodily infirmity, Tull was very irritable, and highly sensitive to criticism, which in his case was monstrously and outrageously offensive. He was also intolerant as regards the perversity, stupidity, and ignorance of his workmen and labourers. By these two things his life was continually embittered; poor Tull with overstrung nerves certainly did not attain to Charles Kingsley's ideal:

The world goes up, and the world goes down,  
And the sunshine follows the rain;  
And yesterday's sneer and yesterday's frown  
Can never come over again.

Patient reader—this is a Tullian phrase—"patient reader," before reaching the regular and chronological biography of Tull, it may be well to glance at the state of agricultural knowledge immediately preceding the Tullian era, and, to understand Tull and his life-work, it is almost necessary to consider briefly the agricultural, social, and political condition of the England of his day. It is well also to premise that there are very few materials for a biography. In Tull's own book there are invaluable autobiographical touches, literary manna to be carefully garnered and husbanded. So far as can at present be ascertained, only two persons who knew him personally have left written records of facts and impressions. One of these has been already referred to, the very able gentleman of Hungerford who wrote in the *Gentleman's Magazine* for 1764. His biography is the one foundation upon which all subsequent compilers have built. The other person who knew Tull intimately—a regular correspondent, who visited at Prosperous, and was often visited in town, was Charles, eighth Lord Cathcart. His MS. diary gives names, dates, and facts very exactly, although unfortunately the narrations, except on great occasions, are too often wanting

in detail and colour. Some thirty years ago, Cuthbert Johnson, F.R.S., an able and voluminous agricultural writer, took infinite pains, as a labour of love, to collect materials by search, by correspondence, by advertisement, and by the offer of a money reward. Yet, though happily his quest succeeded to some extent, he failed in tracing even the place where, after life's fitful fever, all that was mortal of weary Tull was laid to rest. Mr. Cuthbert Johnson<sup>1</sup>—who has generously sown for others to reap—thus prefaces his valuable MS. collection: "I have laboured to collect information for a personal history of this famous man, but to little purpose—his own incidental notices of himself are the most important."

To digress for a little while in the directions just now suggested: the art of agriculture, in the sense of practice with science, flourished under the Romans—Virgil, that prince of Latin poets, wrote his *Georgics* about thirty years B.C.—then agriculture pined and dwindled away during the dark ages A.D. 486–1400, being kept alive only by monasticism and by the learning of the monks. An interesting illustration of this fact appears in a recent publication.<sup>2</sup> Walter Mapes, canon of St. Paul's, archdeacon of Oxford in 1196, wrote in the Welsh language a still extant treatise on agriculture. When Caxton, the wonderful London haberdasher, set up his printing press at Westminster, a fresh and ever-increasing impulse was given to British agriculture, which has continuously ramified and extended to overspread the civilised world. Agricultural biography, chronologically arranged, containing a notice of the life and writings of the British authors on agriculture from the earliest date in 1480 to 1854, has been usefully compiled by Donaldson: he founds on previous works by West and by Loudon. A glance at the evolution of agricultural science during the period now in question, namely, from the general use of printing to the date of the new husbandry of Tull, should be useful and instructive. No doubt every inventor has stirred up some pre-existing but latent germs of his discovery. Tull is the eighty-first name on the list of recorded agricultural authors. On analysis, thirty-

---

<sup>1</sup> I am greatly indebted to Dr. Cuthbert Johnson, of Waldronhurst, Croydon, for having placed at my disposal the Tullian Collection of his late uncle, Mr. Cuthbert W. Johnson, F.R.S., barrister-at-law—a Collection which could have been formed only by an able man, after devoting to a congenial task much patient and laborious research. His personal contribution is chiefly a review and critique of Tull's book. A very appreciative notice of this voluminous agricultural author will be found in Donaldson's *Agricultural Biography*, London, 1854.

<sup>2</sup> *Gerald the Welshman*. Henry Owen, B.C.L., Corpus Christi Coll. Oxon. London. 1889.

one names may be eliminated as dross—unknown, unworthy, obscure. This leaves forty-nine authors, thus distributed: seven judges or lawyers, four bishops and clergymen, eleven scholars, college dons, or Fellows of the Royal Society, five soldiers, five land agents, four farmers, three tradesmen or citizens, two farriers, two country gentlemen, one ambassador, one dissenting minister, two surveyors, one gardener and seedsman, and one medical man. Truly, it has been well said that in other things as well as in politics important reforms usually come from without.

These are grand and ever to be remembered names: Littleton and Fitzherbert, both judges, the latter really the father of British husbandry, his work (1534) *The Booke of Husbandrie*; old Tusser with his rhyme and reason, of whom it was well said, "Thou teaching Thrift could never Thrive!" The older writers had a provoking way of mixing up agriculture proper with extraneous matter, as a chapter "on Brewing Compound Ale, a general purge and a generous medicine." The author of *Adam out of Eden*, 1626, Adam Speed, Gent., mentions turnips, potatoes, clover, hops, and flax. One of Gervoise Markham's books has a nice suggestive title, namely *Cheap and Good Husbandry*. Sir Richard Weston, ambassador (1645), by his *Discourse of Husbandry as used in Flanders* laid the foundation of an improved agriculture in Britain. Turnips, clover, flax, and other crops were previously known in England, but differed from the crops grown in Flanders as wild plants differ from those under cultivation. Hartlib was a superior person, a friend of Milton and rewarded by Cromwell; in advance of his day he suggested the foundation of an agricultural college, and died in poverty.

The Civil War made the country gentlemen poor and consequently industrious. After the Restoration they became dissipated, and husbandry for a long time was left to the tenant farmer. Pepys notes this fact, "Our gentry are grown ignorant in everything of good husbandry." The Revolution brought many eminent characters to the front, one of whom was Walter Blythe (1649). The City of London in his day petitioned against two nuisances, "Newcastle Coal in regard to the Stench; and Hops to spoil the taste of Drink." He, like Sir Richard Weston, advocated the cultivation of green fodder plants and roots. John Evelyn's illustrious name needs no heralding; philosopher, soldier, diplomatist, the *Terra* (1658) and his *Sylva* are known to all well-read agriculturists. Evelyn also wrote in his Diary, 1684, "London is so filled with the fuliginous steam of sea-coale that hardly could one see crosse the streetes." Yarranton in 1663 had an eye to the



purchase of sound seed: he mentions clover, and drilling, that was, dropping seeds in a furrow by hand as in a garden.

Worlidge in 1669 is the first to direct attention to ray grass; he suggests drilling corn, and gives a cut of a theoretical drill. After the invention of his own drill, Tull mentions this implement. Bradley, an eminent agricultural writer of those days, showed him the cut of Worlidge's drill, which he said was only a proposal and never made but in the cut.<sup>1</sup> Bradley spent 25*l.* in making one, and when finished it would perform nothing. There was no sort of structural analogy between this suggestion and Tull's subsequent invention. The views of Worlidge in regard to agriculture proper are scientific, but his knowledge of animals was very imperfect. Gabriel Reeve, of Hackney, then (1670) a rural district, is worthy of honourable mention, because, having been a practical farmer for thirty years, he travelled in Flanders "and there he saw a lesson to be learned." The potato as a field-crop is first mentioned (1681) by John Houghton, F.R.S. Donaldson was a Scotch writer of considerable repute who, whilst showing others the true and solid way, was himself always in the ditch. His book, *Husbandry Anatomised*, was published in London in 1697, and certainly was of considerable repute. Lord Cathcart had it when a boy, and it is again mentioned in a second list of his books, which included also *Adam out of Eden*. A country gentleman—"Campania Felix"—recommends, in 1700, hand manures as malt dust and pigeon's dung. My Lord Bishop of Ely (1707) chose a curiously suggestive title, *Curiosities of Nature and Art in Husbandry and Gardening*. John Mortimer, in the same year, wrote the *Whole Art of Husbandry*; the book is a distinct advance, being comprehensive and systematic, yet even he digresses in the most provoking way—trees, liquors, ale, cider, and gooseberry wine. Mortimer was a sort of early English Alderman Mechi, of Tip-tree fame. Forty bushels of hand-sown soot to the acre produced, he says, "a mighty sweet grass." 160 bushels of hot lime to the acre lasts five years. In addition to soot he recommends other hand manures, as ashes, soap ashes, rags, and malt dust. The spade used in paring and burning, of which there is a cut, is exactly that in use in our day. He advises broad-cast turnips on fallow, for consumption in March. "Few farms," Mortimer observes, "will carry three rents."

Giles Jacob, gent., 1717, had good ideas on horse-breeding—like breeds like and that sort of thing. Dr. Bradley, F.R.S., a

<sup>1</sup> There is a copy of the cut in the Cuthbert Johnson Collection—an ugly sort of great hopper, or funnel, square on the plan, mounted on four high velocipede-like wheels.

college Don, recommends (1721) a cross between the Barb horse and the English mare: the horsey Don distinctly loved a shapely and bright bay with black points. He wrote the first systematic book on the animals of the farm. Poultry, however, are not mentioned. Edward Lawrence, land surveyor, 1726, is worthy of honourable mention. He was an enlightened man, and contributed materially to the advancement of agriculture; his condensed style marks a new era. His cash and rental books, in form, are good to our day. Turnips, well hoed and cleaned, greatly improve the land, and should be fed off on the land by sheep. Vetches, both summer and winter, are great improvers. He suggests—clover seed, 12 lbs. per acre; ryegrass, 13 bushels per acre; sainfoin, 4 bushels per acre; lucerne, 14 lbs. per acre; lentils, tares, and buckwheat.

Brigadier Mackintosh wrote in 1730. He was an educated man, of sound and comprehensive views. Lord Cathcart, in his diary, mentions the Brigadier having visited him in Edinburgh Castle on the agricultural business of the Society of Scotch Improvers.

This hasty and imperfect retrospect may, to some extent, serve to illustrate the general law of continuous evolution, with constantly accelerated velocity, and to indicate more particularly the gradual—the very slow and gradual—evolution, during the period in question, of the art of agriculture in its relation to science, and how that gradual evolution prepared the way for an original thinker and reformer—in short, for the advent of Jethro Tull.

The pen of no mortal man could paint a wordy picture of the social, fiscal, and material condition of England at the Tullian era, as Hogarth with intense realism has painted to the life the men and women of all degrees, and the streets and places of London in which they lived and moved and had their being. To understand Tull perfectly and the men and women of his day, from the great gouty peer in his easy chair to the Grub Street scribbler and the beggar in the gutter, turn over carefully and mark, learn, and inwardly digest a collection of prints after Hogarth.

Lord Macaulay's<sup>1</sup> famous third chapter of the first volume of his *History* should be studied by the curious reader as complementary to this biographical sketch, and as the finest and most graphic wordy picture, painted on the most extended canvas, of the then, and immediately preceding, state of England, at a period a long way antecedent to the time when the commercial

---

<sup>1</sup> See also Mr. Lecky's *History of the Eighteenth Century*, vol. i.

element outgrew the agricultural. Turn to the map of London in those days. To the north, cattle fed and men with dogs wandered for sport over the site of Marylebone, Finsbury, and the Tower Hamlets. Islington was a solitude. To the south of the river, there was a mere fringe of houses and gardens, with the great Lambeth marsh. To the west, St. George's Hospital was in the fields. To the east, the London end of Whitechapel Street led at once into the country. Londoners, then as now, were gregarious: the gentleman about town talked of dining at his club—a tavern club; and taverns and coffee-houses there were of every kind and degree.

But in those days a wide line divided the town from the country. In our time, when the traveller breakfasts in London and dines comfortably in Edinburgh, it is difficult to realise the conditions of locomotion in Tull's day. It was easy enough, as we have seen, to get out of London; and then, in those pre-Macadam days, the highways were simply infamous—dry ditches in summer, and wet ditches in winter. Gradients were unconsidered, the way uninclosed from the fen or common over which it passed, and many deep-trodden tracks converged at a bridge or ferry, with inundations in which the traveller, floundering in darkness, might have to swim for his life. In 1725 Lord Cathcart mentions in his diary that he travelled north in June: the roads were full of water, there was the very greatest difficulty in crossing the rivers, and in his chaise he was completely wet through. In riding post there were constantly terrible falls. In January, 1734, he writes: "All went well until I arrived within three miles of Doncaster, when, suddenly, my horse fell with a crash and with me under him. I fancied myself crushed to death. I got on a mile further, but was then obliged to send for a Doncaster surgeon, who bled me. I slept at Doncaster and had a bad night. I was so bad all day I could get no further than Wetherby. Next day I was all right again, and read the King's speech with great pleasure. I had another terrible fall between North Allerton and Darlington, but was not a bit the worse." Not only were the roads, and the chaises, and the post-horses discouraging to the traveller, but there was always the exciting prospect of meeting the highwayman or the footpad and of being, in the disagreeable encounter, mulcted of felonious toll. The one redeeming feature amongst all these drawbacks and discomforts was the roadside inn, which, more often than otherwise, was clean, warm, and comfortable.

Who'er has travelled life's dull round,  
Where'er his stages may have been,  
May sigh to think he still has found  
His warmest welcome at an inn.

These miserable and dangerous roads, the ruts often by measurement four feet deep, with the wrecks of broken-down waggons strewed by the roadside, led to provincial towns very different from those which exist in our day. Manchester was a poor, ill-built market-town, with a population, all numbered, of some 6,000 souls. Birmingham was a much smaller place, and Leeds was a town only a little larger than Birmingham.

The roads, such as they were in those days, traversed thousands of square miles of moors, or furze-breaks, or fens, which are now in our day smiling cornfields. One-half the area of the kingdom was then moor, forest, or fen—and the population of England did not exceed  $5\frac{1}{2}$  millions. Commons and common fields prevailed, with a consequent intermixture and debasement of stock, amongst which infectious diseases, scab and rot, and every other sort of plague of a like nature, were disastrously rampant. Tull complains bitterly of damage done and quarrels caused by stray sheep. The statute-book since Tull's time contains thousands of Enclosure Acts; ten thousand square miles or more have been reclaimed at the sole cost of the landowner. Without any expenditure of public money, a fourth part of England has been turned from a wild to a garden. To understand Tull and his times it should always be borne in mind that in his day and long afterwards England was a wheat-exporting country; the products of the soil at that time far exceeded in value the fruits of industry.

Born as the present generation is to steam transit by land and by sea, it is difficult in our day to appreciate in any sense the difficulties in old times, before soldiers and Macadam constructed scientific roads. Difficulties of locomotion not only prevented the fusion of persons and of classes, but the well-springs of intelligence and education were dammed at their source, and the general distribution of food and commodities was rendered well-nigh impossible. Sir Walter Scott said he knew a man who remembered the Scotch mail arriving in Edinburgh from London—all England addressing all Scotland with one letter. Civilisation, indeed, advances hand in hand with locomotion.

The agricultural produce carried on the then existing infamous roads was comparatively inconsiderable. Transport from London to Birmingham was 7*l.* a ton; from London to Exeter, 12*l.* In 1696 the whole wheat, rye, barley, oats and beans annually grown in England was computed at less than ten millions of quarters. Wheat was grown only on strong land; the quantity estimated at two millions of quarters; and it was exported or consumed exclusively by well-to-do persons. The sheep and the oxen of those days, when, generally speaking, green crops were unknown,

being starved in winter, were consequently puny. Cattle were killed when the grass failed in early autumn, and the beef was salted down for winter; and at that season game and fresh-water fish were the only procurable fresh animal food.

And now, and most important of all, we come to consider the provincial persons who used these Slough of Despond roads, because these people together formed the disjunct inert mass that, with extraordinary courage, Jethro Tull set himself to move in a new and unwonted direction. The country gentleman was usually poor, and often little better educated than his groom or his gamekeeper; his pleasures were derived from the sports of the field, and his too often pot-house language was racy and redolent of the province from which he derived his origin. The farm-yard was at the back of his house, and cabbages and gooseberries grew by his front door. Yet in many respects the esquire was a gentleman: pride of family and family tradition made him sensible of responsibilities and jealous of his honour. In London the mere country squire was altogether out of his element, and looked and felt like a bumpkin, stared at by every passer-by. They certainly drank in those days—all classes; as claret was expensive, the tippie was strong beer. Beer was then not beer only, but everything that is now consumable in the nature of wine, tea, and spirits.

The rural clergy, the rank and file of the Church as a whole, were generally disregarded as a plebeian class, and probably behaved accordingly. Anyway, they were certainly not usually instructed and enlightened men: helpmates meet for Tull and his undertakings. The yeomanry were a manly and true-hearted, but unimpressionable and very dogged race, the stuff out of which Cromwell created his Ironsides; they were more numerous than the tenant-farmers. These small proprietors, with their families, were estimated at more than one-seventh of the whole population, their average income was supposed to be 60*l.* or 70*l.* a year. The tenant-farmer of those days was of inconsiderable importance; his instincts accorded with those of the yeomen; they taught him that the Tullian system, requiring as it did space and appliances, threatened his very existence—he had then given no promise of the great future that awaited his class; with neither money nor book-learning, the tenant-farmer blindly trod the shallow and crooked furrow which had been turned by his sire and his grandsire and his fore-elders from time immemorial.

Another and irresistible cause subsequently converted the yeomanry and small farmers into wage-earning labourers. Domestic industries formed an all-important element in the household economy of the small farmer: these home and consequently

dispersed industries were altogether superseded by the concentrated and crowded manufactories of the huge cotton-spinning and other industrial communities. It has, moreover, been truly said: Deduct from agriculture all the practices that have made it flourishing, and you have precisely the management of very small farms.

It was then without any doubt amongst the great and enlightened landowners—men devoted to landscape gardening and husbandry, the statesmen, the soldiers who in “Anna’s Wars” had served in Flanders, the scholars, and travellers, and, above all, in the most influential combinations of such men associated in the Scotch and Irish Societies of Improvers in Agriculture—that, as he himself cordially acknowledges,<sup>1</sup> Tull found in his endeavours appreciation, encouragement, and that which is the most sincere of all flattery, namely, intelligent and successful imitation.

Jethro Tull, the scion of an ancient Berkshire and Oxfordshire family, and heir to a competent paternal estate, was born at Basildon, in the county of Berks, in the fourteenth year of King Charles II.; he was baptised at Basildon on March the 30th, 1674, as “Jethro, the sonne of Jethro and Dorothy Tull.” The father represented a branch of the family that was long seated at Midgham, in the Kennet valley, between Newbury and Reading. A John Tull of Midgham died of the plague in 1603, and was buried in his orchard; shortly afterwards his wife Joan was carried off by the same pestilence. In 1641 Giles Tull was churchwarden of that place. The grandfather of the subject of this biographical sketch was one Giles Tull of Midgham, and from him in due form a pedigree has been deduced.<sup>2</sup> The name of Tull to this day abounds on the borders of Berkshire and Oxfordshire and the regions round about. The antiquity of the family is further vouched by an extract from the public records,<sup>3</sup> which establishes the fact that in the time of King Edward III.—1327—there was seated at that place a “Johān Tulle de Cobham.”

Jethro Tull, the agricultural author, matriculated from St. John’s College, Oxford, on July 7, 1691, then aged 17 years. He does not appear to have taken a degree. He was admitted

<sup>1</sup> Speaking of his system, “If it be ever common it must be made so by gentlemen,”—the great gentlemen farmers—“as other improvements have been.”—Tull’s Notes on the Preface.

<sup>2</sup> By the author of *Basildon Notes*: see note on p. 39. This learned gentleman cites authorities and says the name of Tull is Norman, from Tull-Noelant in Normandy. The name appears A.D. 1272 in connection with English manors.

<sup>3</sup> *Cuthbert Johnson MS.*

a student of Gray's Inn on December 11, 1693, and was called to the Bar on May 19, 1699. It is recorded in the Order-book of the Society: "Mr. Jethro Tull had full standing in commons, performed his exercise, paid his duties, received the Sacrament, and has a chamber in his own right." It is recorded also that he had two years' standing at Staple Inn, and that he was the only son and heir of Jethro Tull, of Howberry, in the County of Oxford. The original bond, dated Easter term, 1699, to duly pay charges at Gray's Inn, is, with signature<sup>1</sup>—"J<sup>e</sup>. Tull"—and seal, in the Cuthbert Johnson collection.

Later in this year, Tull married—namely, on October 26, 1699—Susanna Smith, of Burton-Dassett, in the county of Warwick, the bridegroom being described as "Jethro Tull, of Gray's Inn, gentleman." Mrs. Tull was of good family; this is particularly stated by the Hungerford friend, the original biographer, and it is further evidenced by the numerous existing tombstones in the chancel of Burton-Dassett church and in that churchyard.

The poor lady, commencing married life at an early age, probably trod an uphill and thorny path. Nothing is known of her beyond this: she survived her husband, and had one son and four daughters. As recited, she had a jointure, possibly a marriage settlement; but was not the executrix of her husband's will, which might well have been a "damnosa hæreditas." Mrs. Tull was more or less a woman of affairs, as may be gathered from this circumstance: on Sunday morning, February 28, 1731, she called on Lord Cathcart, at his house in Queen Street, Westminster, and just as he was going to church, no doubt—as indicated by adjoining entries in the diary—on her husband's urgent private affairs.

Tull studied law, not as a profession, but to investigate the principles of the Constitution, hoping to make a figure in public life; he also, and probably with the same object, made, as was usual with educated men in those days, the grand tour of Europe. Habitually a diligent observer, nothing escaped his attention. We are told he especially noted soils, culture, vegetable productions, methods, and implements. In the French vineyard culture he discovered what he thought one general method of cultivating to advantage all land in all countries. This tour was probably made between the years 1693-9, after his studentship at Gray's Inn, and before his call to the Bar and marriage. On his marriage he settled on a paternal farm in Oxfordshire.

---

<sup>1</sup> A facsimile of Tull's signature as it appears on this bond is given in the frontispiece.—(ED.)

This farm was Howberry, in the parish of Crowmarsh—being separated from Wallingford only by the Thames. Of the extent and exact position of this farm occupied by Tull nothing is certainly known. Generally speaking it is said the land in the parish is very fertile: the soil belongs to the Upper Greensand formation, rich in phosphate of lime in the form of coprolites, and bears heavy cereal crops, the wheat and barley being of the highest quality. It is particularly adapted to the growth of peas and beans, and bears heavy crops of sainfoin and other fodder plants, and potatoes, and altogether this land would appear well adapted for the purposes of experimental farming. The family circumstances that caused Tull to diverge from the course in life he had proposed to himself—namely, politics—and to take to agriculture are unknown. It was, he says, “accident not choice, made me a farmer, or rather many unforeseen accidents.” The further reasons he himself has made plain. He says:—

As to agriculture, it was not by choice, but by a sort of necessity, that I practised it; and I never kept an acre in my hands that I could reasonably dispose of to a tenant. I knew too much of the inconveniency and slavery attending the exorbitant power of husbandry servants and labourers over their masters, to propose to myself any other gain by occupying land but to repair the injuries done to it by bad tenants, and to keep it till I could let it at a reasonable rent to such as I thought good ones. I have occupied only two farms; the first was in Oxfordshire. I so much improved that farm in nine years as to let it for above a third more rent than it was ever let before; and that being almost thirty years ago, the rent is not sunk yet, but likely always to continue, or increase.

The drill was invented about the year 1701. And this, in substance, is Tull's account of his discovery:—“My diversion in youth was music; I mastered the mechanism of my organ. Plough-servants began to exalt their dominion over their masters, and a gentleman-farmer could make little profit of arable land; mine being that sort, so I resolved to plant my whole farm with sainfoin. Seed was scarce, dear, and bad, and enough could scarce be got to sow, as was usual, seven bushels to an acre. I examined and thought the matter out, and found the greater part of the seed miscarried, being bad, or too much covered, or too little covered. I observed and counted, and found when much seed had miscarried the crop was the best. Then I learned to distinguish good seed from bad, and by many trials found in my strong land that the best seed would not succeed unless covered at a certain exact depth, and I discovered the reason of this nicety. So I caused channels to be made, and sowed a very small proportion of seed, covered exactly. This was a great success.”

Next year the labourers in a body struck against this innova-



tion and were dismissed; as was said in those days, "It were more easy to teach the beasts of the field than to drive the ploughman out of his way. I resolved," says Tull, "to quit my scheme unless I could contrive an engine to plant sainfoin more faithfully than hands would do. I thought and examined all the mechanical ideas that had ever entered my imagination, and at last pitched upon the groove, tongue, and spring in the sound-board of the organ. With these a little altered, and some parts of two other instruments as foreign to the farm as the organ, I composed my machine. The first seed-box was worked on the iron gudgeon of a common wheelbarrow with a brush-harrow to cover the seed."<sup>1</sup> It was named a "drill" because when farmers used to sow their beans and peas into a furrow by hand they called the action "drilling."

Tull goes on to say:—"The drill has been used almost as long in planting most sorts of corn, for hand-hoeing, and subsequently for horse-hoeing. It has been pretended I brought the implement from France or Italy, when it is well known it had planted two farms before I went abroad, which was not until April 1711. How could I have brought that which did not exist?" Tull, even at this time, was above all things a clean farmer and waged unrelenting war against those thieves and robbers of agriculture, weeds. Tull was most particular in cleaning his seed; this he did by drawing it on a table with a table-cloth. His apt similes are happy and characteristic: "The crop of wheat with irregular intervals, under the old husbandry, by being irregular serve chiefly for the protection of weeds; for they cannot be ploughed out without destroying the corn, any more than cannons, firing at a breach whereon both sides are contending, can kill enemies and not friends." Again he says: "Under the old system the plants stand on the ground in a confused manner, like a rabble; ours like a disciplined army."

Tull's invention of the drill may be thus described<sup>2</sup>: The idea taken from the rotary mechanism of the organ is the foundation of all agricultural sowing implements . . . . The first invention was a drill-plough, to sow wheat and turnip seed in drills three rows at a time. There were two boxes for the seed, and these, with the coulter, were placed one set behind the other, so that two sorts of seed might be sown at the same time. A harrow to cover in the seed was attached. He afterwards invented a turnip-drill somewhat similar to the other, but of a lighter construction, and so arranged in regard to the dropping of seed, and

---

<sup>1</sup> *Gentleman's Magazine*, 1764.

<sup>2</sup> See J. A. Ransome's *Implements of Agriculture*.

its subsequent covering with soil, that one half of the seed should come up earlier than the other, and with a view to enable a portion at least of the young plant to escape the ravages of the turnip fly. The manner of delivering the seeds in both these drills was by notched barrels: Tull's essential principle was, in feeding the seeds, the use of cavities in the surface of solid cylinders.

Necessarily in those days there were vast difficulties in construction, the extent of which it is difficult for us to estimate. We now have perfect tools, standard gauges universally accepted and machines for measuring to the one-millionth of an inch. In Tull's day, and long after, inventors—James Watt, for example—were tortured by blundering mechanics with the rudest tools and inadequate appliances. Tull's seed-boxes were made, we are told,<sup>1</sup> “by Mr. Bennet, a very ingenious mathematical instrument maker in Crown Court, Soho.” Turning from the subject of the original drill, now only of historical interest, Tull's own pregnant sentence may be cited as summing up that question: “I owe my principles and practice originally to my travels, as I owe my drill to my organ.”

Nature and wisdom always say the same thing. Tull's attention to detail was extraordinary—perhaps unparalleled.<sup>2</sup> Indoors and out he was always studying the open book of Nature, and doubtless made many notes afterwards utilised in his published book. “No canon,” he says, “having limited what we shall think in agriculture, nor condemned any of its tenets for heresy, every man is therein a freethinker, and must think according to his reason, whether he will or no.” The foregoing fine sentence is no doubt highly characteristic of the man. “It is,” he says, “in the interest of every one who lives by bread that true principles be established in agriculture, but none ought to be allowed as such until they have been thoroughly examined; every man is well satisfied by experiments made by himself.” With the practical eye of an experienced husbandman he experimented, he entered into the habits and properties of plants, their production and nutrition. In sickness even his bedchamber was filled with various plants, with their roots, in whole or in part, so disposed in pure water or mixed fluids as to be under observation. In short, he treated the living, growing sentient plants of the farm as a zoologist or biologist might study the ways, tastes, and habits of some rare and curious animal.

Tull's usual saying, says his Hungerford friend, was this, habitually repeated: “There's more than a rent odds in saying

<sup>1</sup> *Gentleman's Magazine*, 1764.

<sup>2</sup> *Cyclo. Brit.*

to farm-servants, 'Go, do this thing or that,' or, "Come, let us go and do it'"—his version of the proverbial saying:

He who by the plough would thrive  
Must either hold himself or drive.

The practical application of this theory, bodily exertion and exposure, together with the continuous attention necessary to his operations, brought on a serious chest complaint, which rendered it absolutely necessary for him to seek a milder climate in France and Italy: the sunny South, where, in the words of his familiar Virgil, "He might quaff the pendant vintage as it grows." But, before setting out, note-book in hand, he decided to sell part of his Oxfordshire estate, and to establish his family at a farm of his own in Berkshire named "Prosperous," and situated in the parish of Shalbourne. The reasons for selling land were probably other than personal, because Tull says in one reply to his critics, "I have never spent an estate in any manner." Before going abroad he must have been some little time at "Prosperous." His daughter Mary was baptised at Shalbourne in 1710, and "I travelled," he says, "in April, 1711, being above ten years after making and using my drill. . . . I was obliged to travel for saving my life."

Tull tells us:—"I took the first hints of my horse-hoeing culture from the ploughed vineyards near Frontignan, and Setts, in Languedoc, a southern province of France, on the Mediterranean. After my return to England, I improved these hints by observing that the same sort of vineyard tillage bestowed on potatoes and turnips had the same effect on them as it had on these vines. So also in regard to corn. I was thus confirmed in the principles which, by arguing from effects to their causes, I had formed to myself, and my practice ever since has been a further confirmation of the truth of the same principles." He observes further, pursuing his Virgilian studies on the spot and with great zest, "The ancients were perfect masters of the vine- husbandry, which seems to have engrossed their rural studies, that it did not allow them so much reflection, as to apply the use of those methods to the increase of bread, which they had discovered to be most beneficial for the increase of wine." Tull tells us that he travelled through Italy, and shrewdly observed that the patrimony of St. Peter lost when compared with the hereditary estates adjoining. "I went," he says, "the whole length of Italy by land, traversing the kingdom of Naples almost all over, and made a considerable stay in many places thereof." As compared with that of other countries, he was greatly struck by the extraordinary cost of English labour.

After an absence of three years, spent in observation and studies with a view to the practical agricultural objects of his life, our traveller, in 1714, returned with well-filled notebook, from Montpellier in France, "repaired in his constitution, but embarrassed in his fortune." He returned to his Berkshire home, Prosperous Farm, a place for ever famous as the home of Tull for twenty-six years, from this period to the end of his chequered life.

The rural parish of Shalbourne is situated in the south-western corner of the county of Berks; chiefly in that county, but a portion of the parish is in Wiltshire. Partly in both these counties, but principally in Berkshire, is the farm on which Tull laboured and experimented, in health and sickness, in sunshine and in storm, often in need, necessity, and adversity, to perfect the Tullian system and to publish its principles to a then world which, speaking generally, was ungrateful and heedless, if not utterly adverse. This pleasant and secluded spot, in our day known chiefly to hunting-men and villagers, has been, as we have seen, and probably will be again, the object of many and reverential pilgrimages. Tull says of his lone farmhouse: "The lands be so remote from all farmers that they cannot be let without the house where I live, and which is situate in an air that I would not willingly part with." This is Tull's description of the farm "whereon only I have practised horse-hoeing":—"Situated on a little chalk on one side and heath ground on the other, the soil is poor and shallow. It is one of the highest farms in that part of Berks, and may be seen at ten or twelve miles' distance. The bulk of the land is, on the south side, for near a mile in length called Bitham Hills, all on flinty chalk; below is a bottom on chalk also, which has lain for many years with sainfoin. On the west side all the land is called East Hills. On the north-west is a high field called Cook's Hill, the only one not on chalk, a poor, wet, spewy soil. The soil generally is too light and too shallow to produce a tolerable crop of beans. This farm was made out of the skirts of others; great part was a sheep down with a full reputation of poverty."

Arthur Young's "pilgrimage" to "Prosperous" was in 1794, when, covered with glazed tiles of home manufacture, the old house still existed; he calls it a "wretched hovel." Arthur Young, after careful inspection, considered that the description of his farm by Tull was true and just. "Here it was," he adds, "Tull practised and registered that drill-culture which has been the origin of so many experiments, and the basis of so many publications in almost every language in Europe."<sup>1</sup> In the

<sup>1</sup> His own words; *Annals Agric.* v. 23, 172.

Cuthbert Johnson Collection there are sketches of the tumbledown little old granary and little old stable as they appeared in 1840.

Tull had a two-pronged hoe, which he called a "bidens," and, for mellow ground, one with three prongs, called by him a "tridens;" one of these last was found in the mud at the bottom of the well at "Prosperous."<sup>1</sup> A heavy and rudely made hoeing tool, such as an old roadman might use for scraping down and spreading road metal, it was probably pitched contemptuously into the well by one of Tull's bitter foes—an idle, disgusted and ultra-conservative farm-labourer.

Tull says, "I keep a team of horses, but only for the use of my tile-kiln. I do not use oxen, only bulls, bought in when they are cheapest, and I have them castrated." An original in all things, he had for this operation a method of his own. "They are called bull-stags. I yoke three in a hoe-plough." Cobbett, in his *Rural Rides*, mentions two "pilgrimages" to "Prosperous," and writes of Tull's radical husbandry—that is, going to the root—feeding the growing plant by deep tillage. The second visit was on November 20, 1821. Cobbett observes, "with Mr. Budd<sup>2</sup> I rode to-day to the farm of Tull; my companion did the same thing with Arthur Young twenty-seven years ago—it was a sort of pilgrimage."

We are told, by his friend and original biographer,<sup>2</sup> Tull set out at "Prosperous" with a firm resolution to perfect his undertaking in spite of the opposition of the lower class of husbandmen. He revised and improved all his old implements and contrived new ones, and generally pushed on his new system, demonstrating to all the world the good effects of his horse-hoeing culture. He grew without manure successive wheat crops on the same ground for thirteen years, and superior to that grown by his neighbours in the ordinary course, labour and tillage supplying the place of manure and fallow, and with the saving of at least two-thirds of the seed-wheat—a saving in the aggregate of the food of millions upon millions of people.<sup>4</sup>

---

<sup>1</sup> The hoe is said to have been at one time in the possession of the Royal Agricultural Society. Figured in the *Cuthbert Johnson Collection*.

<sup>2</sup> An eccentric attorney of Newbury; an ardent admirer of Cobbett. Many of his published letters are dated from Budd's farmhouse, Burghclere.

<sup>3</sup> *Gentleman's Magazine*, 1764.

<sup>4</sup> Sir John Lawes was so good as to read this paper, and he has favoured me with the following observations:—"Tull is quite an original genius, and a century in advance of his time. I consider he has been most unjustly accused of not placing sufficient value upon farm-yard manure; he advocated cleanliness, and saw dung was a great carrier of weeds. To give some clear idea of the value of Tull's advocacy of drill husbandry, and the freedom from weed, which can alone be obtained by the use of the drill, I may mention that, so far as statistics will allow, I have ascertained the average yield of the wheat crop

Tull's ploughs and other implements were in principle and in effect the rude forerunners of the perfected and world-famed British implements of our own day; so also his scrupulously clean husbandry, with drilling and horse-hoeing, with deep and constant tillage, is inseparably associated with the modern and most improved principles of the art of agriculture.

The exact details of Tull's practice are now subjects only of historical, not of practical, interest. The curious reader is referred to his book, in which every detail is amply set forth; the illustrations of the implements invented and used are excellent. The instinct of true genius in poor, worn-out, much-abused Tull was prophetic, and in the faith thus modestly and pathetically set forth he died:—"Some, allowed as good judges, have upon a full view and examination of my practice, declared their opinion that it would one day become the general husbandry of England."

That the Scotch farmers were the first to discover the merits of Tull's system is a fact recorded by Loudon. Boswell mentions, in his *Life of Johnson*, that in 1773, at Rasey, in the Hebrides, the great man told us that Dr. Campbell called on him, and they talked of Tull's husbandry. Campbell said something, and Dr. Johnson disputed it. "Come," said Dr. Campbell, "we do not want to get the better of one another, we want to increase each other's ideas." Dr. Johnson took it in good part, and the conversation went on coolly and instructively. Northumberland in 1780<sup>1</sup> borrowed the system from Scotland, and it gradually worked its way southward. The Tullian system, as has been said, was first taken up by certain of the great landowners of England—as, for example, Lord Ducie<sup>2</sup> and Lord Halifax<sup>3</sup>—and afterwards with great zeal by the Society of Improvers in the Knowledge of Agriculture in Scotland, a Society founded in July 1723; it lived a short but invaluable life of twenty-two years, and perished in 1745, during the distractions of the then civil war. During the whole of its life, Mr. Hope of Rankielor, the last President of the Society, was the life and soul of the Society in Scotland: a man, as Chambers well says,<sup>4</sup> who deserves to be better remembered than he is. He was the intimate friend and

---

of the world, and I am able to say that the average yield is less than it is at the present time upon my permanent wheat land, after more than sixty years absolutely without manure. Here we have the result of Tull's three great principles—drilling, reduction of seed, and absence of weed. If he were alive now and were writing for the agriculture of the world, he would, I think, be quite justified in saying everything he said in regard to cleanliness and manure."—C.

<sup>1</sup> *Northumberland Survey*, p. 100: *Cyclo. Brit.* vol. vi.

<sup>2</sup> Matthew-Ducie Moreton, created Lord Ducie, &c., 1720. Died 1735.

<sup>3</sup> George Montague, Earl of Halifax, K.B. Died 1739.

<sup>4</sup> *Dom. An. Scot.*, iii. 485.

correspondent of Lord Cathcart, and what Hope did in Scotland Lord Cathcart zealously seconded at the seat of government in London; and hence the interest of the Cathcart Diary in connection with the life of Tull. It has been truly observed—and it is a fitting preface to the Diary—that from the illustrations that lie around a subject, and opposite and parallel to it, we must seek at once elucidation and embellishment. The dashing Grey Dragoon, bred to arms in the school of Marlborough—the Diarist, born in 1686, was twelve years younger than his friend Tull, and died the same year, namely, in 1740, whilst in command of the expedition to Carthage.<sup>1</sup>

The Diarist first mentions farming on April 17, 1725: “At five this morning I left *en chaise* to be with Lord Halifax at eight o'clock. He showed us his gardens at Bushy, of which park he was ranger, and at his other lodge, Abbs Court, his horses, his farm, his cows, and everything interesting that he had, and in a manner most interesting and obliging. We dined, and returned to London in the evening.” In June 1726, the Diarist in Scotland was elected President of the Society of Scotch Improvers. He says, “I supped with them.” Again, “I spent the evening with Hope of Rankielor and others of the Society at a tavern, conversing on many projects.” In July: “I presented Hope to the Duke of Argyle,”<sup>2</sup> who gave a half-promise to visit the Ayrshire scene of the Diarist's Scotch farming operations. Passing over meetings of council and a general assembly of the Society in February 1727, mention is made of the Englishman in the Diarist's Scotch farm employ.

In April the Diarist had a visit from his friend, Hope of Rankielor, who greatly approved of his works, his system, his hedges, his trees, the manner of working the land, of the burnt earth, and the manner of draining by bavins of brushwood; in fact, Hope approved of everything. In May, the Diarist was busy in working with his levelling instruments, and happy in showing his agricultural and landscape works to his lady visitors. “Peggie Bellenden,”<sup>3</sup> a young lady celebrated in the

<sup>1</sup> See the works of Tobias Smollett. “Expedition against Carthage.”

<sup>2</sup> John, second Duke; born 1678; commanded at the Battle of Sheriffmuir Dumblane, where the Diarist is credited with having, under the Duke, saved the day by leading a squadron of dragoons over a then frozen but usually impassable morass. (Lord Mahon's *History of England*, &c., vol. i, chap. v. 2nd revised ed. Murray, 1839) The Duke is commemorated by Pope—

“Argyle, the State's whole thunder born to wield,  
And shake alike the senate and the field.”

Tradition, or Sir Walter Scott—equivalent terms—says the Duke was interested in all details—a thorough practical farmer.

<sup>3</sup> Margaret and Mary Bellenden, daughters of John, second Lord Bellenden,

memoirs of those days, is specially mentioned as one of the party; the fact is interesting as showing the interest taken even by fine ladies from town in the country pursuits of almost inaccessible Scotland. On July 14, at the King's levée in London, the Diarist witnessed a presentation, which marked an era—he saw “the Quakers presented.” Later in the month our Diarist writes, “I was with the King in the evening, who asked me about my plantations.” In August he again visited the farms at Bushy and Abbs Court.

In July 1728, the Diarist gave Lord Townshend,<sup>1</sup> who was much interested, an account of the Scotch improvers, and also of Thomas Hope, with a view of getting him a provision of 200*l.* a year. Lord Townshend received this proposition very graciously. In 1729 there was some special agricultural subscription in which Hope and the Diarist were interested; he gave as his subscription 5*l.* for three years. The Duke of Argyle, his brother Lord Ilay,<sup>2</sup> Frederick Prince of Wales and others also subscribed. On one occasion the Prince asked the Diarist if in Scotland he had many horses. “Yes, sir,” was the reply, “a great many, but they all go in the plough!” And on April 2 the Diarist writes, “I went to Sir Robert Walpole—the Prime Minister—and for the same object he paid me his subscription.” This incident of the subscription is interesting as giving the names of some of those practically interested in agriculture. On March 18 the Diary further records, “I had a long conversation with Lord Ducie about agricultural improvements; he asked me to visit him, that I might judge for myself of the advantages of the Tullian system.”

On April 8, 1730, the Diary records: “I went to Court, where I had a long conversation with Lord Halifax about the operations

---

ladies celebrated in the memoirs and poetry of those days. Horace Walpole says of the last-mentioned lady, a maid of honour to the princess: “I never heard her mentioned by anyone who did not prefer her as the most perfect creature they ever knew.” She married Col. John Campbell, a groom of the Bedchamber—was the mother of the fifth Duke of Argyle, and died 1736.

<sup>1</sup> Charles Townshend, Viscount Townshend, Lord President of the Council, born 1676, died 1738: the colleague and rival of the Prime Minister, Sir Robert Walpole. In an age of corruption, Townshend passed his public life in handling political pitch, yet finally retired into private life with hands clean and undefiled. Lord Townshend was an enthusiastic farmer. Having, as Secretary of State, attended his master, King George I. in his visits to Hanover, Lord Townshend studied turnip husbandry there, and on a large scale introduced that system into his county—Norfolk. It is interesting to observe how one great step in advance leads to another. Tull and Townshend prepared the way for Bakewell, who, with a view to improve the animals of the farm, travelled abroad, like Tull, to study, and then experimented.

<sup>2</sup> Archibald, Earl of Ilay, second son of the first Duke of Argyle, 1682–1761, and afterwards Duke of Argyle. Managed the Scotch business of the Government for Robert Walpole.



of Tull, and of Hall, a Papist attorney near Hungerford, on their manner of enriching the land with tares : 10 acres fattened 200 sheep in a summer. Later, I went to buy a barometer." On April 21 : "I was with Sir Robert Walpole<sup>1</sup> this morning, and then to Court, where I had a long conversation with Lord Halifax about my Scotch improvements, of which he much approved." On April the 28th : "I went to Court, and afterwards to the House of Lords, where I had a long conversation with Lords Bathurst<sup>2</sup> and Litchfield about agricultural improvements."

On May the 9th the Diarist writes : "Lord Halifax pressed me to be of a party to go and see Tull at Abbs Court; I accepted. I dined with Scarborough,<sup>3</sup> Chesterfield,<sup>4</sup> Albemarle,<sup>5</sup> Deloraine<sup>6</sup> and Schultz." This must have been an interesting dinner party, and no doubt Abbs Court and Tull were subjects of conversation, because Lord Scarborough, the Diarist's greatest friend, was brother-in-law of Lord Halifax. Lord Chesterfield—then Lord Steward of the Household—was the celebrated lord, the author of *Letters to his Son*. Colonel Schultz held some office at Court, a man of wit; he is celebrated in Pope's *Court Ballad* as a punster.

On May the 24th : "After dinner I walked with the King, who questioned me regarding my manner of planting trees." A day or two later, Sunday : "I went with the King to Marble Hill<sup>7</sup>—a charming place—the King constantly asked me the names of trees." On June the 11th : "After dinner I had, on the terrace at Windsor, a long *tête-à-tête* with the King; the King talked of employing certain regiments to clear and level roads through Windsor Forest, and said that he was not quite sure the Colonels approved. 'Yes, sir,' I said, 'they will like the duty; I know one at Kinsale [*i.e.* the Diarist himself] who would be very 'happie' to offer his services.' The King laughed heartily and said, 'I believe you would work for nothing.' 'Yes,' I added, 'and, to boot, pay our own marching money.' The Duke—the young Duke of Cumberland—invited me to his supper." On

<sup>1</sup> Sir Robert Walpole, Earl of Orford, Prime Minister of England, 1715-17 and 1721-42.

<sup>2</sup> Allen Bathurst, first Baron and Earl, born 1684, distinguished for wit, taste and learning; died in his ninety-first year.

<sup>3</sup> Richard, second Earl of Scarborough, K.G.; died in 1740.

<sup>4</sup> Philip Dormer Stanhope, fourth Earl of Chesterfield, K.G.; died in 1773.

<sup>5</sup> William Anne Keppel, second Earl of Albemarle, K.G., a soldier; died in 1754.

<sup>6</sup> Francis Scott, second Earl of Deloraine; born 1710, died 1739.

<sup>7</sup> Marble Hill, a little villa near Twickenham, belonged to Lady Suffolk, see *post*, page 25. Lords Burlington and Pembroke designed the house. Lord Bathurst and Mr. Pope laid out the gardens, and Gay, Swift, and Arbuthnot were self-constituted superintendents of household.

July the 22nd: "I went on horseback this morning to see the works in Windsor Forest: in less than two days several miles of road have been levelled. I saw nearly all the officers, who begged me to hint to the King that on this service the subalterns were at great disadvantage, which in the evening I did not fail to do. I did full justice to officers and men; the King was surprised and charmed at the work done by the troops." July 23: "Out walking I told the King of the character of Thomas Hope and of our Scotch improvements. The King was well satisfied, chiefly in regard to our manufacture of linen of Cambray, which would prevent English money going to France. The King seemed pleased with what I said in regard to Thomas Hope." August the 10th: "The Duke of Dorset<sup>1</sup> promises to interest himself about Hope." August 13: "I walked in the evening with the King, and read to him a letter I had from the Duke of Chandos,<sup>2</sup> thanking me for having taught his people to burn clay—a wonderful success." On August 14: "I had an invitation from Sir Robert Walpole, asking me to visit him at Houghton in Norfolk."

These incidental records of the names of some of those interested in the agricultural affairs of that day are the best evidence, so far as they go, as to the men, or some of them, and as to the influential Scotch Society which from the first appreciated and adopted the Tullian principles—principles that, for want of due care and interest, men such as those named, and many others of their class and power, would never have willingly allowed to die.

Abbs Court, or Apps Court, a manor one and a half mile north-east from Walton-on-Thames, celebrated in song by Pope, was inherited by Lord Halifax; situated on an open plain adorned with noble elms and oaks, it has a pretty look-out towards Hampton Court. Here, at this half-way house, surrounded on the home farm by instructed, intelligent, appreciative great men from London, we can picture to ourselves poor Tull in his glory. Having for the moment escaped from his everyday surroundings, his wife Susanna and her girls, "his hovel of a house" at Prosperous, and his idle, mischievous labourers, he is in the enjoyment of the few happy hours of a life usually rendered miserable

<sup>1</sup> Lionel Cranfield Sackville, seventh Earl and first Duke of Dorset; died 1763.

<sup>2</sup> James Brydges, ninth Baron and first Duke of Chandos, created 1719, known as "the Princely Chandos;" died at Canons, near Edgware, in 1744. Canons, the "Timons villa" of Pope's satire:

"At Timons villa let us pass a day

Where all cry out, 'What sums are thrown away!'"

The glory, however, was of brief duration:

"Deep harvests bury all his pride has plann'd  
And laughing Ceres reassumes the land."

by bodily suffering and petty annoyances amounting in the aggregate to mental torture. Fancy him at the age of fifty-six, as in the characteristic portrait<sup>1</sup>—which, if not by Allan Ramsay,<sup>2</sup> is at least of his school—arrayed in his best ruffled velvet coat and full-bottomed wig; and having dined well, he is depicted as demonstrating, with index finger extended and self-satisfied expression, the excellences of some excellent part of his agricultural system—a charming discourse, spiced, no doubt, with humour, and delivered with the ease of a scholarly gentleman, together with the dignity of an intuitive philosopher.

The Diarist's — Lord Cathcart's — visit to Tull at "Prosperous" was on Monday, September 7, 1730. On the Friday previous he drank tea *en famille* with Mrs. Howard—Lady Suffolk,<sup>3</sup> in those days a person of the greatest influence—and explained to her his object in going to Pontypool, which was to enlarge his knowledge of smelting and of iron manufacture. The next day he did not go out hunting with the Court, as he was preparing for his journey. The Queen was gracious, and asked why he travelled to Wales. The King asked the same question, and very graciously granted leave. Queen Caroline was a woman of great ability, a good and firm friend; her Majesty subsequently headed the list of the subscribers to Tull's book. The "Wizard of the North" has, with magic power, reproduced for us the men and women of that day—the Queen, the Duke of Argyle, Lady Suffolk, and many other interesting illustrations of this biography, English and Scotch, will be found in the *Heart of Midlothian*.

On Sunday, September the 6th, when the Diarist started at half-past nine o'clock, it rained hard; he dined at a little inn, where he picked up some useful agricultural information. From thence the ten miles to Newbury was done in fine weather. He supped with the family of Colonel Schultz. On Monday morning, the 7th, at half-past nine o'clock, the Diarist arrived at Prosperous Farm, where he was delighted with Mr. Tull, who showed him over his property, and explained without the least reserve his whole system. The Diarist left at 3 o'clock, and young Tull set

---

<sup>1</sup> Agriculturists are indebted to Mr. Martin J. Sutton, of Reading; he has, with great public spirit, purchased this interesting portrait, in order that, in the public interest, it may be safeguarded. The portrait of Tull was formerly in the possession of Mr. John Richards, F.S.A., of Camden House, Reading, the founder of the Berkshire Ashmolean Society. At his death, in 1840, it was bought by the late Mr. John Snare, of Reading; his widow, Mrs. Snare, of Kelburne Lodge, Wokingham, sold the portrait to Mr. Sutton.

<sup>2</sup> Allan Ramsay, the painter, was a fellow-countryman and friend of the Diarist.

<sup>3</sup> Lady Suffolk's *Letters*, 1712-67, London: Murray, 1824,

him on his way as far as Marlborough; thence to Bath. The roads were very bad onwards to Bristol, near which place he met Miss Vane, a lady well known in the memoirs of those days<sup>1</sup>—"she pretended to be more ill than she really is"! On horseback next morning, at half-past four A.M., to pass the Severn with the tide; the traveller arrived too soon, and passed the time at a very nice inn. Terrible roads in Monmouthshire. He arrived at Pontypool at 8 in the evening of the 9th, thoroughly wet through, and slept in a miserable inn. Next day with Mr. Hanbury. Passing over a great deal that is interesting enough, but not of agricultural interest, the Diarist, after dinner, left his host on the 12th, with much regret, having been treated with great goodness. The Severn was impassable at New Passage, so the road to Chepstow was taken; at Chepstow he took a guide to Lydney, arriving at Nymphsfield on Sunday the 13th: "Here," he says, "I changed my linen," and arrived at the house of Lord Ducie, who was in bad health and in bed. After seeing him, the Diarist supped with Mr. Moreton, the son and heir of the house, who was most kind and obliging—it is pleasant to trace a family likeness in an old picture, and to observe how agricultural proclivities tend in some families to become hereditary. Next day my lord was much worse, and they considered him in great danger. Mr. Moreton, with Mr. Adderlie, their agricultural manager, showed all the undertakings, which were very satisfactory and much admired. The site of the house is admirably chosen, and the view of the Severn very beautiful. On the 15th, at 10 o'clock, the Diarist left Woodchester Park, and Lord Ducie, who was rather better. Mr. Moreton conducted him by a beautiful valley to Hampton. Near Cirencester the Diarist was picked up by Colonel Selwyn<sup>2</sup> in his chaise: "we went seven mortal miles over infamous roads to breakfast at Wanborough." On Sept. 17, again at Newbury, the Diarist wrote to young Tull, and, resuming his journey *en chaise*, arrived at Windsor at six o'clock in the evening. He dined with the young Duke of Cumberland, and was received by him and by the princesses, his sisters, with great demonstrations of pleasure; the Duke was greatly attached to the Diarist, whose own two boys were about the same age, and playmates. Next day the King and the Court received him well; he says: "Lord Halifax paid me great compliments on the information I had gained concerning agriculture."

<sup>1</sup> Horace Walpole's *Letters*, vol. i.

<sup>2</sup> Colonel John Selwyn, equerry to the Queen, father of the better known George Selwyn, celebrated as a wit. The passion of this really tender-hearted man was to see coffins, corpses, and executions. He died in 1791, æt. 72.—See *Memoirs of George Selwyn*, by Jesse and Horace Walpole.

Lord Ducie, who, we are told, "accompanied" Tull in his operations—that is to say, the noble Lord's operations kept pace with Tull's—is twice and very suggestively mentioned in the *Horse-hoeing Husbandry Book*. In reply to critics, Tull says: "Can it be reasonably believed that a person of his Lordship's known good sense and judgment would have continued the practice of a scheme so many years and annually increased it, unless he had seen it succeed, or if upon the whole he had been a loser by it? I believe my Lord might be two or three thousand pounds out of pocket or more, but most of this money was expended upon building walls, making new ways, inclosing commons and common-fields, planting miles of quick hedges, and constructing houses and farm-buildings. I never heard there was any loss by the husbandry, but the contrary. It would be the highest reflection upon a person of his Lordship's honour and integrity to imagine he would approve a scheme on which he had observed for many years, if he had not been convinced by his own knowledge and experience that it was just."

And again an instance occurred in the case of a nobleman well skilled in agriculture, presumably Lord Ducie. He had two arable estates. On that near home Tull's four-coultered ploughs had been used with success. Some, therefore, were sent to the other and distant estate. On a subsequent visit it was found not one furrow had been ploughed with them. Bailiffs, steward, servants, and all, said the ploughs might be all very well on the one estate; yet the land was different, and they were no use here. No argument of my Lord's prevailed; so at last he went into the field himself, set the coulter, threw off his coat—and ensigns of honour—and ploughed a whole land, and so shamed the ploughmen that they condescended to plough well with the four-coultered ploughs. The moral is grandly Tullian—no new implement can expect fair play when the master is taught by servants.

The following extract from Lord Cathcart's Diary appropriately closes his agricultural year, 1730. December 2: "I went this morning to teach Sir William Strickland and his manager how to burn clay;" and again, December 4: "I stayed at home for a long conference with Sir William Strickland's agent: I explained to him many things concerning agriculture of which he was ignorant, and also my system of accounts, with which he was greatly pleased."

The year of grace 1731 saw the commencement of the publication in London of Tull's *magnum opus*, in the shape of his *Specimen of a Work on Horse-hoeing Husbandry*, in quarto—five chapters of the afterwards completed book; this,

to the intense disgust of Tull, was immediately reprinted in Ireland—pirated without acknowledgment; and in those days there was no legal remedy. So Tull writes, fearing that the whole work in like manner would be pirated, “I was come to a resolution to publish no more.”

The year 1731 was a Tullian year in Lord Cathcart’s Diary, January 12: “I wrote to Lord Stair and to Mr. Tull.” This was the Diarist’s relative and the chief originator of the Scotch Agricultural Society, Maréchal Lord Stair:<sup>1</sup> there was a trade in black cattle between the Maréchal and Lord Halifax, as in Sir Walter Scott’s *Two Drovers*, which traffic Lord Cathcart arranged. January 18: “Tull the younger and others dined with me.” January 21: “Mr. Tull called on me this morning.” Saturday, January 23: “Very frosty, I was this morning with Lord Bingley,<sup>2</sup> with Mr. Tull: my Lord greatly approved Tull’s system.” January 28: “James Campbell is very ill; I was with him.” Young Tull was fourteen years afterwards on Campbell’s staff as aide-de-camp. Sunday, February 28: “Mrs. Tull called on me in the morning before I went to church.” March 10: “I went at 7 o’clock to Rothe’s; we started with Lord Stair for Abbs Court, where we saw them drilling sainfoin and barley at one and the same time. We had a very agreeable walk all over the farm, and dined at Hampton Court with Lord Westmorland, and in good time returned to town.” March 12: “I had this morning a long conference with Mr. Tull. Yesterday wrote to Thomas Hope.” March 24: “Went on foot to Highgate to see a theodolite: then to call on Colonel James Campbell, who is better: afterwards to the House of Lords with the King: went to a coffee-house at St. Mary-le-Grand about selling Sauchie—Scotch—coal: called also on Lord Sempill, the Duke of Dorset,

<sup>1</sup> John, 2nd Earl of Stair, K.T., Field-Marshal, second in command under King George II. at the battle of Dettingen, Ambassador to France on the death of Louis XIV. The Earl died in 1747. He was the Diarist’s first cousin, and with him, as with others, at that time landscape gardening was a passion, and landscape gardening and home farming went hand in hand: he was a devoted agricultural improver. Bridgeman and Kent were then the two great professional landscape gardeners, and some of their work may be traced at the present day. They were advocates of a natural system as opposed to the hard lines, right angles, and clipped monstrosities of the Dutch school. Kent laid out Kensington Gardens, and amongst others he worked for Lord Burlington at Chiswick and Lord Cobham at Stow. The Diary so often cited is full of evidence of the passion which then prevailed in regard to that delightful art, which is the creation of the most pleasing pictures out of nature’s own locally available materials.

<sup>2</sup> Robert Benson, M.P. for the City of York, raised to the Peerage as Baron Bingley, 1713. His daughter Harriet married George Lane-Fox. She was the heiress of Bramham Park in Yorkshire. The beautiful park and gardens Lord Bingley there created remain to this day monuments of his taste and liberality.

Mr. Grant, and Dr. Haye." March 27: "Sissen came to me this morning to teach me how to plot the angles taken the other day with the theodolite. I dressed the King,<sup>1</sup> who spoke much about my regiment and strongly recommended me to keep up its strength. . . ." April 5: "I went to the House of Commons to hear the debate about Gibraltar. Letter from Mr. Tull." April 6: "Went to Lord Halifax and had a long interview with him touching the affairs of Mr. Tull." April 15: "A long conference with Mr. Tull." April 16: "A letter from Mr. Tull." April 17: "A visit from Mr. Tull." May 8: "A letter from Mr. Tull, which I answered at once." May 12: "Letters from Mr. Tull." May 21 (in Scotland): "Visited Lord Loudon and saw his home-farm." June 7: "Saw Lord Stair's home-farm, Castle Kennedy, and was not edified." June 10: "Long conversation with his manager on the method of Tull." August 31: "Letter from Young Tull." October 24: "Showed Lord Crawford my plans and the theodolite." October 30: "At home drilling wheat *à la* Tull."

November 7: "Went on Sunday to see Lord Drumore's farm near Edinburgh, which is altogether good."<sup>2</sup> November 9: "Dined at a tavern with Duncan Forbes of Culloden and Thomas Hope of Rankielor." November 13: "Dined at Hope Park, where they showed me the new winnowing machine." November 22: "Visited Lord Stair at Newliston; my Lord showed me his farm before dinner, which is in very good order; I did not approve of his manner of drilling."

Half a word fixed upon or near the time and spot is worth a cartload of recollection. These necessarily imperfect and fragmentary extracts are very typical of the day, and interesting as showing how much amongst landowners agriculture was the fashion and a subject of interest; the extracts show also that Tull was a man about town, and in conference, confabulation, and correspondence with most influential friends. And, further, after much persuasion, the considerations and communications just suggested lead up to Tull's consent—his disappointments notwithstanding—to publish, as originally intended, the whole work on Horse-Hoeing Husbandry.

---

<sup>1</sup> Groom of the Bedchamber to King George II. when Prince of Wales. Groom of the Bedchamber to the King, and subsequently Lord of the Bedchamber.

<sup>2</sup> The day before he reviewed his old regiment, the Scots Greys, and dined at a tavern with General Wade and his old comrades. All were well satisfied the one with the other. This was the famous general who made the Highland roads celebrated by the inscription:

If you had seen these roads  
Before they were made,  
You would hold up your hands  
To praise General Wade,

“I was prevailed on,” says Tull, “to change my design—not to publish any more—by several letters, one of which, from a noble peer, I make bold to insert.” It is dated “London, February 8, 1732;” on February 11, three days later, Lord Cathcart says in his diary: “I wrote to Mr. Tull; meanwhile he came to see me.” This letter that follows was probably written by Lord Halifax, and the blanks should be filled in with the name of the Diarist. The letter runs thus:—

My dear Sir,

— showed me your letter to him of the third of this month. I am extremely sorry to observe from it that you are under great discouragements at present. I am much interested in your preservation, from the happiness I have of a personal acquaintance with you, as well as from the concern I think the public has in a person who has laboured so successfully in its service. I would fain hope that the apprehensions you had from your spitting of blood are, long before this time, removed by its having ceased. If that is the case, I must conjure you, for the sake of your own glory, and for that of your country's benefit, to apply heartily, and without loss of time, to the publishing of your work. If you cannot get an amanuensis from Oxon speedily, pray let — send you one from hence. I am persuaded the subscription money will go far towards printing your book; but, if anything should be wanting, you may be assured that your friends here will contribute towards having a work so beneficial communicated to the country, and in a way that the profit arising from the sale of the book shall return to yourself. The hardship that has happened you from the re-printing your book at Dublin might easily have been prevented, if we had foreseen that the thing was to have happened; but now that we are aware of that inconvenience, you may depend upon it your friends will either get a stop put to the printing from hence, or by the means of the authority of my Lord Lieutenant of Ireland.—I am ever, with great esteem,

My dear sir, Your, &c., —.

“At length,” says Tull, “overcome by the importunities of noblemen and gentlemen of South and North Britain, as well as of Ireland, I unwillingly printed and published my humble essay.”<sup>1</sup>

From a biographical point of view the evidence of this letter, together with the extracts from the diary, are of the utmost importance. They show the impression made at the time on highly placed persons, men of the world who knew Tull personally and intimately, statesmen, soldiers, and courtiers, who had no sort of motive to flatter or exaggerate. Obviously they liked Tull personally, they considered his health and life of public importance, they regarded him as labouring for his country's benefit, and looked upon him as a public benefactor.

It is amusing to contemplate Tull in his character as a

---

<sup>1</sup> In connection with Ireland, Tull says, in reply to a request for an instructor, “No Englishman of his would venture his health in Ireland.”



courtier; he evidently mended his best pen when he wrote: "The reason there is no dedication to my essay is this: the Queen having done me the honour to subscribe to my book, I could not dedicate it to any other person, and her Majesty's royal virtues being too far above any panegyric I was able to write, I chose rather to leave it to the protection of the royal license and the laws."

The first edition of the *Horse-hoeing Husbandry* in folio<sup>1</sup> appeared in 1733, and to this a supplement was added in 1739. The book was at once translated into French, and subsequently into various Continental languages. During literary gestation and delivery, poor Tull suffered infinite pain; and immediately after delivery there was war to the knife. The fruit of his brain and its author were, as we shall see hereafter, continuously exposed to the most cruel, unjust, and savage attacks of carping critics.

"I was," says Tull in his preface, "so far from being inclined to the scribbling disease, that I had disused writing for above twenty years. I was too ill to assist when the MS. was transcribed for the printer; I was never able to correct a proof; my scribe misplaced my notes, and they did not appear in connection with the text they were intended to explain:" the scribe, ignorant of country affairs, often placed the cart before the horse. Tull groans over the trouble he underwent in connection, especially, with his plates of the implements, "with an infernal train of mechanics, scribes, printers, drawers, engravers, &c., &c., who, taking advantage of my confinement, put me to a double expense—towards which the subscriptions did next to nothing—also by delays, tricks, and fraudulent practices gave me such an embarrass that if I had foreseen I would not have underwent." Always in regard to his book Tull speaks with the modesty which is the characteristic of true greatness. "For my part, I pretend to no other merit but my endeavour to answer the desires of my friends." He writes touchingly of the inadvertencies that happen to the pen of a person in pain; because he cannot write but in a hurry.

Obviously the best commentary on Tull's book is the book itself, and in preference, as the voluminous notes are arranged

---

<sup>1</sup> The following editions are thus noted in Alibone's *Dictionary of Authors*:—"Specimen of a Work on Horse-hoeing Husbandry.' Lond. 1731. 4to. 'New Horse-hoeing Husbandry.' 1733. Folio. (Supp. 1739. Folio). 1739. Folio. 1751. Folio. 1753. Folio. 1762. 8vo. 1772. 8vo. In French by Duhamel. In English, new edition by Cobbett. 1822. 8vo. 1829." The French say Voltaire was a disciple of Tull. Voltaire was in England, 1726-28.—*Grand Dictionnaire Larousse*. Art., Tull.

with the text, Cobbett's edition;<sup>1</sup> but Cobbett leaves out all the implement matter as obsolete. The explanatory plates in the earlier editions, however, and in the *Gentleman's Magazine*, 1764, are excellent. This, in his own words, is what Tull proposed to himself when he began to write his book; but a glance at the table of contents, as printed in the foot-note, will show that the work, as was well said at the time, "ripened under his hands":—

"I. In treating of roots, it is proved that they extend horizontally to a much greater distance from the stem than it is commonly thought; and that they are in this, and in all other respects, by nature, adapted to receive the benefits of horse-hoeing husbandry.

"II. The natural and artificial pastures of plants are described.

"III. It is shown how this artificial pasture is raised by dung and by tillage, and what difference there is between the one and the other means of raising it.

"IV. That deep and proper hoeing is a sort of tillage that can supply the use of dung; and that it is for want of this tillage that few plants are brought to their full perfection.

"V. The rules for putting this husbandry into practice are shown, as far as the author's experience reacheth.

"VI. All the particular instruments necessary for that purpose are described in cuts by the inventor, with directions how to make and use them."

"My readers," Tull says, "will not accuse me of breach of promise for having exceeded my proposals."

To treat adequately of Tull's science, to recognise in his thoughts and operations the germs of subsequent discoveries, would tax the ability of a consummate scientist. The science of chemistry and that of vegetable physiology, especially chemical science, is advancing almost daily and by rapid strides. The science of Tull and his forecasts, the flash of intuitive genius, the results of imperfect experiments conducted continuously, but with inadequate appliances, are—and this cannot be too often repeated—to be judged by the standard of his own day, not of

---

<sup>1</sup> In Cobbett's edition the table of contents is thus:—Preface by Mr. Tull; chap. I., of Roots; II., of Leaves; III., of Food of Plants; IV., of Pasture of Plants; V., of Dung; VI., of Tillage; VII., of Hoeing; VIII., of Weeds; IX., of the Virgilian Husbandry; X., of Turnips; XI., of Wheat; XII., of Smuttiness; XIII., of Blight; XIV., of Saint-foin; XV., of Lucerne; XVI., of Change of Species; XVII., of Change of Individuals; XVIII., of Ridges; XIX., of the Difference between the Old and New Husbandry; Addenda to the Horse-hoeing Husbandry; Notes to the Preface.

ours; and so judged and so measured, the overtopping mental stature of Tull stands out grandly when projected on that distant and little-worked-upon background.

Tull's was essentially a fact-finding disposition; he had the true instincts of a man of science. "Truth," he said, "is like gold, the more tried the brighter—experiment for yourself." Again, and the phrase bears repetition, "in agriculture, that is, in science, every man should be a freethinker. Water when it runs off soon is beneficial; where it remains it is injurious." "It is a vulgar error that the winter rains do not enrich the earth." Tull writes of "water carrying down some impregnated earth," and of "strong land that is tenacious of such impregnated particles." His entire theory on the province of water as an instrument or vehicle in vegetable nutrition is most suggestive. He was acquainted with the rain-gauge and greatly interested in the records of rainfall. He worked with his microscope, but the instrument, he says, was a bad one, particularly in examining water in the roots of plants, and, to his apparent surprise, he found the water clear and limpid.

Tull appears to have been greatly exercised in regard to this proposition: "It is the vessels of plants that make the different flavours, the flavours are not in the earth until it has entered and been altered by the vegetable vessels."

Before proceeding further to consider Tull's science, it is only fair to cite his own words in regard to manure; he fully recognised that dung was a serious obstacle to clean farming, as it conveyed the seeds of weeds. He says: "The vulgar in general believe that I carried my farm-yard dung and threw it in a river. I have no river near; besides, my neighbours buy dung at a good price; but it is known I neither sell nor waste any dung. Against such lying tongues there is no defence."<sup>1</sup>

The greater part of the MS. before referred to of Mr. Cuthbert Johnson, F.R.S., consists of a review and criticism of the book of Tullian husbandry. The MS. probably contains to his day—that was thirty years ago—the best estimate of Tull's scientific knowledge. As limitations of space forbid a transcript, it may be useful here just to glean a little from the pages of this competent, able, and painstaking writer. "Pulverise the soil, and prevent exhaustion by weeds, is the essential Tullian principle. Tull says horse-hoeing keeps plants moist in dry weather, counteracting the bad effects of drought by pulverisation, and adds, 'dews are the richest present that the atmosphere gives to the earth.' He knew sulphur and nitre exist in the

---

<sup>1</sup> Addenda to *Horse-hoeing*.

air; dew has both of these substances. The chemistry of 1732 did not enable him to distinguish between nitre and nitric acid—aquafortis—but he did distinguish ‘an acid spirit in the air,’ and ‘much of the nature of aquafortis.’ Here he was giant strides in advance in the knowledge of his day.”

Dews, he thinks, are exhaled from rivers and moist lands, and from the expirations of vegetables. Dew is re-exhaled from waste ground, but most of that which falls on well-tilled land is retained. He well knew that rain-water contains foreign substances. Could we compute the quantity of earth—in his mind the food of plants—in rain-water, it might correspond to the quantity of earth—food of plants—taken off annually by the wheat. Tull experimented on roots with a view to ascertain how they absorb food; he placed plants of mint in plain water, salt and water, and partly in both salt and fresh water. Some he placed partly in milk, others in a strong infusion of garlic, with other constantly varied experiments, and noted the effects for his practical object.

The gases in his day were all confounded under the name of air; he was aware, however, that air passes into the leaves of plants, and that without air plants die. Enthusiasm in regard to tillage made Tull appear, as has been observed, to run a-muck against farm-yard dung, which, no doubt, with poorly fed animals, in Tull’s day, was poor stuff; twenty to thirty loads per acre were constantly used. He appreciated hand manures, especially peat ashes, which he carted twelve miles. He had a considerable knowledge in regard to capillary attraction, and the absorptive power of finely pulverised earth.

Tull drilled his turnips in six-foot ridges, sometimes in a single, sometimes in a double row, fourteen inches apart, and used dung; “it is useful, for turnips have commonly less time to grow than other plants.” He pleaded earnestly for wide intervals between the ridges of wheat, to be horse-hoed. Tull’s system, as to pickling wheat, is, in many parts of the country, followed to this day. He was also well aware of the importance of change of seed; flax-seed, he says, “brought from Holland and sown in England will bring as fine flax as there, but the very next generation is coarser.”

Tull, according to Wren Hoskyns, did not push his theory far enough: where his theory halted his practice began to fail. He did not know the object of stirring was to admit freely air and water, which contain all the organic elements of vegetation—hydrogen, carbon, and ammonia. Had he known this he would have avoided the erroneous theory which led to his want of due appreciation of the chemical value of manure as opposed to its

purely mechanical action. A very recent writer in a work of authority<sup>1</sup> thus sums the Tullian theory and with this preface: "Tull studied the principle of growth in plants, and with extraordinary, perhaps with unparalleled, attention to surrounding details. The food of plants—in his view—consists of minute particles of earth, and consequently the more worked and stirred the more is there food range for roots. Hence rows and drills wide apart, and tillage of intervals by plough and hoe and until near maturity."

If the spirits of just men made perfect could look down upon sublunary affairs, how the shade of Tull would rejoice in the chemical science of our day! This recent experiment would just be after his own heart:—peas, vetches, clover and lupins grown in sterilised sand. The plants cannot thrive—dwindle—there is no nitrogen beyond that in the seed. Add a little liquid extract of good soil, and watch the transformation: these same plants shoot out and flourish exceedingly. How a recent paper in the *Transactions and Proceedings of the Royal Society* on the sources of nitrogen in vegetation<sup>2</sup> would open his eyes to so much that was hidden and obscure! No word but amazement would describe his attitude on learning that it is supposed there are little germs essential to vegetation, and microbes in the soil which require to rouse them into vigorous action, aëration, warmth, and peculiar soil, or, in other words, pulverisation, tillage, draining, and lime. And further, that it is inferred each plant has its own familiar little microbe, to minister to its special wants and tastes, and that the little special microbe helps leguminous plants to obtain nitrogen directly from the atmosphere. But enough; in our day, in the flowing tide of modern science, outsiders are soon beyond their depth, struggling vainly with advancing waves and shouting to the humane man of science for essential assistance.

Usually the inertia of good people discourages more than the opposition of the bad. This was not so in the case of Tull. Acrimonious Grub Street criticism—"their dirty wit"—seemed to have scorched and burnt up his sensitive nature; but all the same, it never prevented his giving a Rowland for an Oliver! Difficulties of communication and a restricted newspaper press in his day, probably by concentration, rendered the venom of unjust criticism intensely venomous, and "Spit forth" to an extent not easily appreciated in our time, when writers and

<sup>1</sup> *Cyclo. Brit.*

<sup>2</sup> *Trans. R. Soc.* v. 180; *Proceedings R. Soc.* v. 47. Sir John Lawes and Dr. Gilbert.

public men are rendered, by endless conflicting newspapers and their attrition, completely pachydermatous. Tull appealed fearlessly to Chief Justice Time, and that grandest of grand juries, Posterity, and the charge agreed with the verdict, and—without the possibility of reversion—it was, and it is, altogether in Tull's favour. By consequence the ears of his virulent maligners are nailed to the literary pillory of history: in the suggestive imagery of the Book of Job,<sup>1</sup> it may be said of these enemies of Tull's—"among the bushes they brayed: under the nettles they were gathered together."

Chiefest in that bad eminence was one Stephen Switzer, a clever, well-educated man; a gardener and seedsman, and himself a reformer in his own art. He was a Hampshire man by birth, but probably of a family of foreign extraction. His garden was at Millbank; he had a stand bearing a sign of the flower-pot in Westminster Hall, close to the entrance to the Court of Common Pleas. He was the head of a Society which contained amongst others a writer whose pseudonym was "Equivocus," so that for brevity Tull called the whole gang of his tormentors the Equivocal Society, or otherwise the Secret Society. He says of them "they have blackened themselves all over with their own ink." It is not necessary for the present purpose, which is only to convey a just impression of Tull's manly life and surroundings, to do more than to cull from their writings a few beauties of literary and critical style. Tull says "the Secret Society—the Equivocal Society—likewise are not content with abusing my vegetable principles, and terming me an atheist, but also describe me by the similitude of the most odious, despicable, and pestiferous animals. They also usurp the power of the Inquisition of damning books because not their own. And again, they, the critics in question, seldom make use of any other logic than that of Billingsgate; they call me names—atheist, infidel, fool, mente captus, madman, ass, owl, viper, carping insect, &c., all feminine arguments of scurrility."

The following extract is from a book supposed to be unique,<sup>2</sup> named *The Practical Husbandman and Planter*:

And now what is there that could induce this author—Tull—to fall [in so unmannerly a manner as he has] on one of the best authors of antiquity [Virgil] and whose husbandry has stood the test of so many ages, but a too high conceit of his own opinion above that of all the rest of mankind. He might indeed have attacked a Bradley or even a Woodward (as he has done) with pretty good success; but a Virgil is certainly an Over-

<sup>1</sup> Job xxx. 7.

<sup>2</sup> In the library of Mr. Robert Hogg, LL.D., F.L.S., to whom I am indebted for the extract.—C.

match for him, and 'tis much to be wondered at that Virgil's translator,<sup>1</sup> who has so just a value for him, should let this great adept pass so long unobserved. If wit be the case, he ought to have taken care at whom he level'd it, lest like Liquour that is squirted into other People's faces, it should recoil back upon his own, and make him the Ridicule of every Reader. A conceited envious critick (and such must that Author in this case be) is a sort of Viper who (being continually nibbling at every author that comes in his way) is one of the most pestiferous Mortals that is; nor can he (as is visible in those ill-natured Remarks) escape the most admired Poet that ever wrote, though it be one who, like Steel, polishes every subject he touches, and whose metal is so hard as to break the teeth of all little carping Insects.

The learned, obliging, and fortunate possessor of the unique little book from which this elegant extract is taken appends this just, if exclamatory note, "So much for honest, unselfish, patriotic Jethro!!"

"Death and the Husbandman" is one of the spirited pictures in the series of the "Dance of Death:" there is the old husbandman holding a wheel-plough, to which four great horses are yoked, and all are vigorously engaged in drawing the last crooked furrow of the field: under the brow a village with smoke and life, and in the middle distance, glorified by the rays of the setting sun, there is a church: in order to finish off the furrow, Death, in a short shirt, skips merrily along, whipping up the leaders. Holbein, at "Prosperous," would probably have sketched Death as a mischievous agitator standing in a cart haranguing poor Tull's ignorant labourers, "whose tongues were even more nimble than their hands," and inciting his besotted neighbours to strikes and opposition; or otherwise as pouring additional gall and venom into the ink of his unjust critics; or more probably still, Holbein would have depicted the only son of the house, John Tull, as being tempted by the enemy to more foolish adventures and bubble speculations.

John Tull had the inventive faculty of his father without his stability of character. Probably through the influence of his father's friend, the Diarist, John obtained a commission in the artillery train, and it is said that at the Battle of Fontenoy he acted as aide-de-camp to General James Campbell, a lifelong friend of the Diarist, and that the General, being mortally wounded, died in John Tull's arms. Subsequently, and more than ever, he was afflicted by the madness of speculation, which then attacked all classes—a sort of reflex of the great South Sea wave. Scheme after scheme was proposed. Some of young

---

<sup>1</sup> William Benson, 1682–1754, critic, politician, author, country gentleman, wrote *Virgil's Husbandry, or an Essay on the Georgics*. First book translated in English verse.—*Dict. Nat. Biog.*

Tull's particular follies are noted in the *Gentleman's Magazine*; <sup>1</sup> history <sup>2</sup> refers generally to such schemes as importing jackasses from Spain, a wheel for perpetual motion, fishing for wrecks, &c. The inevitable end came; he was arrested for debt, and in 1764 died in the Fleet Prison. Jethro Tull, the father, doubtless with due appreciation, left to his son John by will the sum of one shilling.

Poor Tull! it may be inferred that in a financial sense he was pulled down less by bad health than by the extravagance of his improvident son; the father, a man of firm resolves, wrote thus:—

It is to the new husbandry that I owe the property of my farm. . . . I propose no more than to keep out of debt, and leave my estate better behind me than I found it, which unless some accident prevents, I shall perform. . . . But the lands of the farm I have now (Prosperous) lie so remote from all farmers, that they cannot be let without the house where I live, and which is situate in an air, that I would not willingly part with. To avoid this, and yet be out of trouble, as I was likely to be confined to my bed, I prepared materials for building a new farmhouse, and had in a manner agreed with a tenant to enter upon my farm the last summer, which was disappointed by an accident, and now perhaps I may be enforced to keep it as long as I live. However that may happen, I am confident (all things considered) that in the time I have already occupied it, if I had managed it in the common husbandry, the value of its purchase would have been lost by it, though a robust, able-bodied farmer in the clovering and turnip method might have thrived upon it: but every farmer on the old system that has rented it (and here have been few other since it was first made into a farm), that being about seventy years ago, has either broke, or quitted it before the end of his term.

There is reason to suppose that Tull's infirmities confined him to his home at Prosperous for the six years preceding his death, and indeed we are told that during much of that time his many and increasing infirmities confined him to his room; of his hundred acres of drilled wheat he says, "I have not 'seen any of it being confined within doors by many diseases which are adjudged to be the most cruel of any incident to a human body." He adds, touchingly, "I have no one here in whom I can confide." Often—how often—the rewards of mediocrity are immediately paid, those attending excellence being settled in reversion: poor Tull, in reference to the word "glory" in the before-referred-to letter from the noble lord, said pathetically of fame: 'Glory is the reward of warriors attained in the field

<sup>1</sup> A new fish warehouse was opened in Covent Garden Market for the sale of fish brought by land-carriage from seaports at a great distance. Another of the same kind has been opened in Oxford Market. This is a project of Mr. John Tull, son of the late ingenious Jethro Tull, author of the *Horse-Hoeing Husbandry*.—*Gent.'s Mag.*, 1761.

<sup>2</sup> *Hist. Eng. 18th Cent.*, Lecky.



of battle: but in our arable fields the master of them must be a slave to those people who are under the greatest obligation to serve him; and slavery is opposite to victory."

Tull's will was made on the 24th of October, 1739, some months before his death. The preamble recites: "I Jethro Tull of Shalbourn in the county of Berks Esquire being very sick and weak in body but of sound mind and memory praised be God for it do make this my last will" &c. His sister-in-law, apparently a helpful woman, Ann Smith, of Burton-Dassett, spinster, is made sole executrix: his real and personal property to be sold and divided in five equal shares, one share each to his four daughters, the fifth to his executrix. He states that, as his wife had a jointure, he did not think it reasonable to make any addition thereto. For some reason or other, Mrs. Tull—any way, in his later years—scarcely seems to have been a helpmate meet for her husband, to succour, help, and comfort him in his danger, necessity, and tribulation.

The "very sick and weak body" could no longer uphold the "sound mind"—the never-resting, energetic spirit. Death came—not Death the enemy, the morbid creation of a mediæval brain, but the beneficent Angel of Death—Azrael—the friend of poor Tull, friend of all suffering worn-out humanity, the friend of all those whose strength is but labour and sorrow. Jethro Tull died early in the month of March in the year 1740, at the age of sixty-six years.

"No man can tell where the remains of Jethro Tull, the benefactor of his kind, were deposited." So wrote Chambers<sup>1</sup> in his biographical sketch. No loving, no lingering, local tradition, no known record pointed to the hillock of mortality in the dull churchyard beneath which rested all that was mortal of one who by common consent is deemed worthy to be called a "benefactor of his kind." Mr. Cuthbert Johnson, F.R.S., offered a reward for the discovery of Tull's grave, but in vain. After twenty years of pious care, the diligence of a learned and well-known antiquary<sup>2</sup> of the Royal County was, in 1889, rewarded, and his discovery thus published<sup>3</sup> to the world:—

A cursory glance at the registers of the church of this parish (Basildon) shows that they contain many names of historical importance and interest, and by their means the writer has been able to solve a problem which has hitherto baffled all the inquiries and researches of the professional genealogist

<sup>1</sup> *Genl. Bio. Dic.* By Alex. Chambers. New ed. London: 1815.

<sup>2</sup> *Stray Notes of the Parish of Basildon in Berkshire.* By Walter Money, F.S.A., Herborough House, Newbury. I am under great obligation to this learned and agreeable gentleman for all that he has done, and endeavoured to do, to assist me in regard to this biography of a worthy of the Royal County.—C.

<sup>3</sup> *Times*, August 24, 1889.

and local historian—namely, the burial-place of Jethro Tull, the eminent experimentalist in agriculture. Jethro Tull was buried at Basildon, as will be seen from the following extract from the parish register:—"Jethro Tull gentleman of the parish of Shalburne in the county of Berks was buried March ye 9th 1740. Mem.<sup>1</sup>—This Jethro Tull Esquire was the author of a valuable book on agriculture, entitled *Horse Husbandry*.—Geo: Bellas, Rector."

So Tull was born at Basildon, and buried there. That place, situated on a beautiful reach of the river Thames, is eight miles north-west from Reading, and consequently a long distance—twenty miles as the crow flies—from Prosperous and Shalbourne. He must have expressed a yearning desire, after his troubled day on earth, to rest near the peaceful scenes of his infancy and early youth.

The world goes up, and the world goes down,  
And the sunshine follows the rain.

The world of Queen Victoria is not that of King George II. of pious memory. Yet some things remain to us of the old days; for example, the Tullian system remains and universally prevails. The old church of St. Bartholomew at Basildon dates from King Edward II.; its flint and stone dressings, defying time, are in outline sharp as ever; the fine old yew-trees in the old churchyard may flourish for ages; within the western tower of brick, with its pinnacles, the four ancient bells are now as they were long, long before Tull's rejoicing mother, unheedful of future greatness, bore her infant Jethro to be made an heir of everlasting salvation; and the old bells ring out now as they rang when the old church finally received Jethro Tull in its quiet shade; then the old peal rang out once and again its remorseless toll—brave old bells—

Peal out evermore—  
Peal as ye pealed of yore.  
Brave old bells, on each Sabbath day;  
In sunshine and gladness,  
Through clouds and through sadness,  
Bridal and burial have passed away.  
Tell us life's pleasures with death are still rife  
Tell us that Death ever leadeth to Life;  
Life is our labour and Death is our rest,  
If happy the Living the Dead are the blest.

CATHCART.

---

<sup>1</sup> Mr. Bellas was, at the time of Tull's burial, vicar of Basildon, and rector of the neighbouring parish of Yattendon.

## INDIAN AGRICULTURE IN ITS PHYSICAL ASPECTS.

To anyone interested in agriculture a tour in another country than his own cannot fail to be of much profit, and when that embraces a special and definite study of the agriculture of a distant part of the great British Empire, it is surrounded with peculiar interest. Already the growth of an export trade in agricultural produce from India has exercised a considerable bearing upon England itself, and the condition of that vast country with its teeming masses, the greater number by far engaged in the pursuit of agriculture, cannot fail to be a matter of deep concern. Looked at purely from the point of view of an agricultural observer and inquirer, I can hardly imagine any field so fertile in rewarding a careful study as India offers; and when one is privileged, as I have been, to pursue an investigation under auspices so favourable, and with advantages so great as were afforded to myself, he can scarcely fail to return deeply impressed with the general excellence of the native agriculture of India, and with the truly wonderful administration of that great and important Empire.

The object of my mission—one to which I was deputed by Her Majesty's Secretary of State for India—was to endeavour, after inquiry made on the spot, to offer such suggestions to the Government of India as might tend to the improvement of the agriculture of the country, and more particularly that which might result from the teachings of science.

In view of the fact that, although my main conclusions and recommendations have been already submitted to Government, my entire report is not yet issued, I am precluded from entering here into any debateable points as to what the duty of Government should be in the way of fostering agricultural improvement; but it may be of interest to generally review the external conditions of the agriculture of India, and briefly to indicate the principal respects in which its systems differ from our own. This will be my purpose in the present paper.

My residence in India extended over fourteen months, during which I was enabled to travel freely over the six leading provinces of the empire, the remaining two, viz. Burmah and Assam, not being comprised in the scope of my inquiry. I was thus enabled to see as great variations of agricultural practice and conditions as was possible, and to study them during each of the agricultural seasons of the year. That such a review was not only desirable, but absolutely necessary, before any sound conclusions could be

come to, those who are well acquainted with India can readily testify, and the time, alas! has been only too short to exhaust the interest in or to do justice to the subject. However, with the facilities so readily put at my service, I was able to make a tour in each of the six provinces, viz. the Punjab, the North-West Provinces and Oudh, Bengal, the Central Provinces, Bombay, and Madras, and I visited each one twice, viz. once in the cold season, and again during the rains.

The first and most natural differences that strike the newly-arrived visitor are the prevailing heat and the ever-present sun, features playing a most important part in determining the agriculture of India. As the journey is made from Bombay or other seaport into the open country, the town is rapidly left, and many an hour or even a whole day may be passed in the train before another town of any considerable size is met with, for agriculture is the staple industry and occupation of the people. But in place of the wide and often undulating fields of England, the monotony of crop-growing pleasantly broken here and there by the variation of pasture land with its feeding herds of cattle and sheep, we find in India a level plain stretching for many miles along our route, and split up into almost minute divisions, upon which not one but several crops or patches of crops may be seen growing. No hedges nor even stone walls mark the boundaries either of field or holding, for, in all but a few special districts, hedges, properly so called, will not grow, and in other parts one may traverse a thousand miles without coming across a stone even the size of a pebble.

It is not a land of large, but of very small holdings, the average area belonging to a cultivating tenant being only about five acres. On this small space he and his family, and often his brothers or other relatives with their families as well, exist—living, as it were, under a communal system. No trees surround the fields or break the landscape, unless where a poor and barren stretch will not repay cultivation, and has been left to jungle growth or remains a bare parched spot. Along the coast line may be seen dotted here and there the tall cocoanut tree; but its region is soon left behind, and an occasional *palmyra*, or toddy-palm, takes its place. It is only when the journey, it may be of several days' length, brings one to the mountain or hilly regions, that the vast forests are met with and fringe the cultivated area; otherwise, the general appearance of the country is that of a vast, heated, and, apart from the agriculture, uninteresting plain.

The workers we see on these small five-acre holdings are not the day labourers, with the farmer walking busily amongst them, but the tenant himself and his family, each taking his and

her part, and more frequently than not working *on* rather than *above* the ground—a group of scantily clad dusky men and women, here squatting down and busily weeding; here, in a similar position, cutting a crop with hand and sickle, and laying the handfuls side by side until a bundle is gradually formed; there driving along the pair or more of oxen (not horses) that pull the plough which lightly runs through the top surface of the soil but turns no furrow over; there throwing with wicker basket-scoops the water from an adjacent pool or running channel on to the growing crop, or raising it from a well in leathern buckets drawn up by bullocks with a rope and pulley. In place of grazing herds in green fields, there are wandering troops of thin half-starved cattle that roam over the barren tracks, picking up what they can, though hardly a green spot seems to reward their search, or goats that pull down and pluck every green bough or twig that offers itself, or buffaloes cooling their hides in muddy pools, from which if possible they will allow only their heads to emerge.

As we pass on, other changes are noticed: what is now in the cold season a tiny stream, and in the hot season may be dried up altogether, will in the rainy period swell into a vast swift-flowing torrent, and cover the wide bed which now lies exposed. Elsewhere a canal, or its numerous branches, carried off by engineering skill from some great river, brings the all essential water that the crops require, and without which agriculture would in many parts be at a standstill for the greater portion of the year. Yet another feature cannot fail to strike the eye: in some districts are vast plains coated with a snow-like crust and devoid of all vegetation. These are the well-known *reh* or *usar* tracts, the bringing of which into cultivation has baffled nearly every effort, but the reclamation of which would, over many thousand acres, supply food for the wants of an ever-pressing population.

As the days and the weeks go by we have no longer the changes of a fickle English climate, with its alternation of rain and sunshine, but a steady continuance of a long series of days one like the other, but always hot; then, as March is reached, it becomes hotter and hotter, until, when all the country presents at length a burnt-up appearance, there comes, about the end of June or early in July, a tremendous change. The rains descend in torrents, the rivers become swollen and flood the land, and coat the barren spots, as if by magic, with a green sward.

Such are, very briefly, some of the most prominent features that characterise the external appearance of Indian agriculture. But this, though a sketch of what may be seen, is not true by any

means of all parts generally : for I may as well say at the outset that there is hardly a statement that can be made about Indian agriculture, as deduced from any one district, which cannot be met by a precisely opposite statement taken from the experience of another. It has been well said that there is no such thing as *one* country India, or *one* Indian people. It is a continent fifteen times the extent of the whole British Isles, and made up of many countries and many peoples, all totally diverse. So also is it with regard to the agriculture : and in this consisted the very difficulty I had to meet—the impossibility of suggesting any *general* improvement which might be applicable to many parts alike. Each portion of the country must be taken by itself, and in relation to its particular surroundings and circumstances. What those were, it was my duty to ascertain and now briefly to describe.

With the above caution I would say generally that the agriculture of India is, in my opinion, excellent ; and how to improve it is a problem which is, I do not hesitate to say, a harder one than how to improve English agriculture. More than this, I have seen numerous instances of as fine and careful cultivation, combined with fertility of resource on the part of the *raiyat*, or cultivating tenant, as is to be met with in the best parts of our own country. The determining factor with the Indian cultivator is the facilities to which he has access. The excellence of his cultivation is bounded not by the use he makes of the facilities ; indeed, it is wonderful how he does utilise what he has. Nor is it bounded by his want of knowledge, but by the existence or non-existence of the essential requisites to success. I, therefore, unhesitatingly dispose of the ideas which have been erroneously entertained that the *raiyat's* cultivation is primitive and backward, and say that nearly all the attempts made in the past to teach him have failed, because he understands far better than his would-be teachers the particular circumstances under which he has to pursue his calling.

To take first the people, or rather the peoples. Agriculture is, as I have said, the main occupation of the country, and it is estimated that fully 90 per cent. of the rural population is directly engaged in its pursuit. Of the 265 millions that inhabit India, there are about 145 million Hindus, and among these, generally, the best cultivators are found. The 45 million Mahommedans are scattered among the Hindus, preponderating in some districts and being fewer in others. They are a meat-eating race, as distinguished from the Hindus, who, as a rule, are not. Large herds and flocks are therefore in the care of Mahommedans mainly, and they are also the butchers ;

among the Hindus, however, are several tribes and castes whose associations are with cattle, though for the most part with milking and breeding herds. Along the river-sides the Mahommedans predominate, and thither and into the forests the plough and the milking cattle are driven in the height of the hot season.

Without some knowledge of what is implied in the word *caste*, one is unable to appreciate the enormous influence this exerts upon the people themselves and upon their agriculture. At the same time, so complex a subject is the one of caste that without a very extensive knowledge of the country it is impossible to understand it. But that among the Hindus certain castes and races are exceptionally good and others exceptionally bad cultivators remains a fact, and that the differences are frequently to be traced entirely to the respective castes is shown by the existence side by side in the same village of superior and inferior cultivation. Certain castes, as the Brahmins and Rajputs, consider it derogatory to engage in manual labour themselves, and they employ hired labour; low castes, such as the Kachhis, on the contrary, do not scruple to even use the night-soil of town or village, which higher castes disdain to handle, and they are liberally rewarded in a magnificent resulting cultivation. Not only are there these differences, but there are castes who are noted for the special branches of agriculture which they follow: such are the growers of vegetables, the market-gardeners, the cattle breeders, the graziers, the milk suppliers. Each man follows the vocation of his particular caste, and nothing will raise him out of it into a higher one, or make him, if a cultivator, depart from the practice of that caste. The Mahommedan, or, among the Hindus, the low caste *chamar* or the "sweeper" class, may touch a bone, or collect bones for export, but to the higher caste Hindu this would be an unclean act.

In dealing, therefore, with the agriculture of India, points such as these, and many like them, which do not enter into our English agricultural conditions, have to be taken into account. True it is that the influence of caste is beginning to weaken under the spread of education and under the necessity of making the land yield more liberally for the supply of food to its overcrowded population; but it remains a powerful factor still, and one which can only be very gradually removed.

If inherent differences among the people themselves, differences which can only slowly disappear, affect the agriculture, how much must the latter be ruled by that striking feature, the Indian climate, one which neither the State nor the people can

alter? As I have indicated, the seasons are not of the varying nature of our own, but are sharply defined and continuous over the greater part of India. While everywhere and always it is more or less hot, there is a cold season ranging from December to March, during which, with the exception of occasional and uncertain showers at Christmas time, and known as the Christmas rains, no rain falls. This is the period of the *rabi* or cold-weather crops, crops which approach more to our English cultivation, and consist mainly of wheat, barley, numerous pulses, linseed and other oil-seeds. These crops, sown in November, are grown either by the aid of the rainfall of the previous *kharif* or rainy season, which still remains in the soil where it is sufficiently retentive, or, where soil is dry and sandy, by water supplied by artificial irrigation either from wells, tanks, surface reservoirs, or by the wonderful system of canals now carried throughout the country wherever practicable.

By March the cold-weather crops are reaped and the heat gradually increases, until in May and June the whole surface of the land presents a parched and burnt-up appearance, and, except in a few favoured parts, no green thing is visible. Cattle roam over the fields of stubble endeavouring to eke out an existence on what is left, and for about six weeks at this time their life is a very precarious one, for the growing and storage of fodder-crops is not in general practised, nor can the *raiyat* devote much of his small holding to his cattle. It has to keep him and his family, and pay the rent, as well as feed the cattle, so the latter consequently have only the broken straw (*bhusa*) which is left after the grain has been trodden out by the bullocks upon the threshing-floor. Grass the *raiyat* cannot grow, partly for the foregoing reasons, and partly because he has no water to supply to it, whilst more often than not the hills and forests are too far away for him to drive his cattle to for shade, shelter, and pasturage.

Just when everything appears at a standstill and forebodes the worst privation, a sudden change comes over the scene with the advent of the south-west monsoon, about the end of June or early in July, and both nature and cultivator spring at once into activity. The rain falls copiously and the dry earth sucks it in greedily; from being a barren plain, everything presents almost in a moment a green surface, and crops rapidly cover the ground. These are the *kharif* or rainy-season crops, and they are as distinct from, as the others are like, our English crops, for, though it be the rainy season, the weather is just as hot between times, and in some respects much more oppressive than even during the heat of May and June. The crops are those of



a more tropical nature—numerous kinds of millet, rice, maize, sugar-cane, cotton and others. Towards the end of September the rains cease altogether, and—except where, as in Southern India, currents set in from an opposite direction, and the north-east monsoon brings, though not always, the rains of October—no rain may again fall over the greater part of India until the next rainy season. In October the *khariif* crops are reaped, and ploughing goes on briskly on the lands reserved for the winter or *rabi* crops, which are generally sown about November.

But while this description may be taken as true for the greater part of India, it is by no means so for the whole, and it would have to be varied in almost each separate locality, for the very reason that, although the rain comes, it does not come in like quantity everywhere, nor is the soil on which it falls equally retentive. To understand rightly how this is so, one must study the physical features of the country, and also its geological nature. Stretching across the northern part of the continent from west to east, and forming its boundary, runs the great Himalayan range, whilst along the western coast, and in close proximity thereto, are the Western Ghats, leaving an opening between them and the Himalayas. It is here that the vast plains of Sind and Rajputana lie, and through this gap the south-west monsoon can enter. On the eastern side are the Eastern Ghats, whose height, as compared with the others, is insignificant. In these three ranges we have the determining factors, so far as the configuration of the country is concerned, of the different seasons. The earth's surface, in Northern India at least, which towards the close of the year has been losing its heat more rapidly than the surrounding sea, and has thus been enjoying a cold season with its accompanying temperate crops, gets gradually more and more heated up as March comes in, and so it continues, growing hotter and hotter till it becomes quite parched and vegetation is burnt up. Then a south-west current, laden with moisture from the surrounding and cooler sea, rushes in and strikes on the western side of the continent. The high Western Ghats impede its progress and cause it to deposit its moisture in heavy rainfall along the western coasts of the Bombay Presidency. But over the Ghats it cannot pass, and the consequence is that the country on the other side of them remains still a dry and heated plain. Further north, through the opening referred to above as being left between the Western Ghats and the Himalayan range, the monsoon rushes, and passing over the intensely heated plains of Sind and Rajputana (which are mostly too hot to allow the deposition of moisture to take place there), it becomes cooled as it goes farther on, and abundant

rainfall over the northern plains is the result. Over the lofty Himalayas too it cannot pass, but sweeping along gives an extremely heavy rainfall all along their base, and so on over the whole of Bengal, Assam, and Burmah, which consequently are the most wet and damp parts of the empire; here failure of rain is never known.

In these regions and along the Western Ghats the agriculture as a consequence shows a marked difference from that of other parts; it is here and under these conditions that the rice crop flourishes—for rice is not, as is too often supposed, the most general crop grown in India. In like manner, when in October the reverse current sets in and the north-east monsoon blows across the Bay of Bengal, it strikes on the eastern coast of Southern India, the part alone exposed to it. It passes, however, over the low range of the Eastern Ghats, which are not sufficiently high to impede it, and deposits its moisture as rainfall in those districts which, owing to the intervention of the lofty Western Ghats, received none from the south-west monsoon. In this way, in a favourable year, each portion of India receives to a greater or less extent its rainfall at one time or another; according to it the agricultural practice will be determined, the crops grown will vary, and, just as the force of the monsoons varies, so will there be the difference between abundance and scarcity, while, should one or the other fail in any part, the dreaded famine may stare the country in the face.

It is to guard against this latter that the efforts of Government have been and are still being most actively put forward in the supply of water through a system of irrigation by canals, in encouraging the making of wells and storage reservoirs, and lastly in the rapid extension of the railway system throughout the length and breadth of the country—measures which must have the hearty support of all who in any way understand the peculiar conditions of Indian agriculture. It has been necessary for me to explain at some length the action of the monsoons, for without it any understanding of the agriculture is impossible.

Whilst over a great part of India there are thus two clearly defined seasons, a cold and a rainy season, with their respective crops, in the southern part and in the Madras Presidency generally there is a more steady warmth throughout the entire year, and consequently there are not the regular *rabi* and *kharif* crops, but only early and late sowings of the same crops. Wheat, as a result, has no place in this more tropical climate, and though rice is largely grown, it is not by means of the rainfall alone, as in the Bengal and Bombay Presidencies, but

only where abundant irrigation from channels, streams and tanks is available. In Behar, and some other parts of Bengal, there are three rather than two crop seasons, a *bhadoi* or hot season intervening between the cold and the rainy seasons. Then it is that the indigo plant, sown in February, flourishes, and is gathered about the end of June or early in July. Sugar-cane, too, is planted in February, and grows on through the hot season, though needing abundant irrigation for its development, until the rains come and supply the natural moisture.

Along with the rainfall, the soil must be taken as determining also to a large extent the nature of the crops grown. Broadly speaking, India may be considered as divided into three distinct geological series; the first or northern portion, which is one vast alluvial area and comprises the great Indo-Gangetic plain; the second, a central zone spreading over part of Bombay, Central India and the Central Provinces, the soil being known as the black cotton-soil; and, thirdly, a rocky area comprising Madras and Southern India generally. Each division has its minor local distinctions; but, while of the northern it may be said that it is a rich alluvium, quickly drying and needing replenishment by rain or irrigation from well or canal, the black cotton-soil is very retentive and holds ample moisture from the annual rainfall, to enable the sowing of winter crops in November, so that artificial irrigation is hardly, if at all, required. In the third or rocky zone the only way to provide water is by storage tanks, or by channels led from rivers or streams, irrigation from wells being difficult. Thus, in the north may be seen regularly on the same holding the crops of both seasons, the one growing by the aid of well or canal irrigation, the other by means of the rainfall and the powerful heat. In the Central Provinces, on the contrary, are great stretches of cultivation of one and the same kind, in some districts the cold-season wheat and linseed, in others the rainy-season cotton and millets; whilst in Southern India, as explained, the crops go on much the same all the year round, and are distinguished mainly by early and late sowings.

Over individual areas, again, there will be enormous variations in the amount of rainfall, each having its correspondence in the crops grown and the method of cultivation pursued. Thus, crops which depend on a heavy rainfall and a damp climate flourish only in certain parts—Assam, for instance, with its rainfall of from 60 to 160 inches and more, produces tea luxuriantly; Behar gives the indigo cultivation; and rice belongs to Burmah, Eastern Bengal and the western coasts of Bombay. Other crops, such as wheat, require a drier climate, though water

may in some cases have to be given artificially; others again, such as the pulse crops, *gram* (*Cicer arietinum*) or *arhar* (*Cajanus indicus*), can, when once germinated, do without dependence on water, and are suited to a hot, dry climate. The indigo plant, again, is favoured in the development of leaf (the portion used for making the well-known dye) by the damp climate of Behar and Bengal; but the production of the seed goes on much better in the drier climate of the Punjab and the North-West Provinces; and so it is that the two cultivations are carried on in quite distinct parts of the country.

As I travelled about I had ample opportunities of studying the various changes in agricultural practice. To take a single province—the most northern one, the Punjab—we may have, even here in the plains, variations from the seven inches of annual rainfall in Multan to twenty-six inches at Amritsar, and thirty-five inches at Hoshiarpur; and, when one reaches the hills, as at Simla, the rainfall increases to seventy inches and more yearly. In the first-named case canals are absolute essentials to guarding against famine; in Hoshiarpur, on the contrary, the water-level is quite near the surface, and irrigation by wells is practicable everywhere. In the Bombay Presidency we may go to places like Baroda or Neriad, or to Igatpuri (where the rainfall is from 100 to 170 inches annually), and will find rice growing without any irrigation; grass headlands and live hedges too may be seen. But as we pass inland to the Khandesh district the rainfall sinks to thirty inches, and rice is replaced by cotton, millets and wheat, while neither grass nor hedges will grow. South of Bombay, in the Kistna valley, the rainfall is forty inches, at Belgaum sixty-five inches, and at Londa, a comparatively small distance off, as much as 150 inches yearly. The cultivation alters with each set of conditions. *kharif* crops being distinctive features of one part and *rabi* crops of another. Going into Eastern Bengal during the rains one sees the country in great measure inundated, the crops of rice and jute growing, as it were, out of the water itself, whereas, after the floods have subsided, the inundated land and the beds of rivers and streams are the cultivating areas for mustard and cereal crops.

Nor is the influence of varying climate seen alone in the crops, but it is marked in the cattle and even in the people themselves. On the dry plains of the Punjab especially, and also in the North-West Provinces, the bullocks are fine, large and strong; but when we come to the damper regions of Bengal they are found to be diminutive and miserable looking. Buffaloes, however, rejoice in a wet or damp climate, and they flourish in many parts of Bengal and along the Western Ghats,

taking frequently the place of bullocks as plough cattle. The Bengali, clever as he is intellectually, is a poor specimen physically, when put by the side of a Sikh from the Punjab, or even a North-West *raiyat*.

The bearing of an uncertain rainfall on the possibility of famine, and the determining of means to prevent it, are most important points. It is neither in the wettest nor, singular as it may appear, in the driest tracts, that there is the greatest danger of famine. In the former, as also on the moisture-holding black cotton-soil, there is always certainty of sufficient water; in the driest tracts, again, the *raiyat* will never venture on growing a crop unless he is certain of having water enough. But the really precarious districts are those in which there is just the chance of enough rain coming to induce the cultivator to venture on sowing a crop; for, should the rain not come or not continue, there will be a total failure of the crop, and scarcity will result. If this be followed by a second failure, what is known as famine will set in. Happily, the Government have wisely foreseen that it is these precarious tracts which most need the extension to them of means of irrigation; and happily, too, the expansion of the railway system enables the quick transmission of stores of grain. What, however, is still to fear, is, first, that a famine may come in any part before even the authorities are aware of it, for they are so few and so widely scattered, while the people themselves will never complain, but bear their misfortunes in silence; secondly, the simultaneous occurrence of famine in different regions, for, there being no stored reserves of grain in the country, it is only possible to imagine how direful in its effects such a calamity must of necessity be.

Next to people and climate, a word more must be said about the soil than has already been included. But little is known about it beyond what the cultivator himself knows practically. The main geological types are few, but the local subdivisions are many, and for each of these the *raiyat* has his particular name, and the knowledge of what it will best produce. There are no peaty soils, nor anything akin to our gravels, oolite or chalk soils, nor yet to our heavy clays, but there are the vast plains of alluvium already referred to, the singular black cotton-soil, and subsoils composed of a concretionary kind of limestone known as *kankar*. Classification of the soil according to its capabilities is the system on which assessment of the land revenue (for the Government is practically in the position of landlord) is based, and this is modified according to the various local circumstances, the facilities for irrigation, &c. In a country where irrigation plays so important a part, the relation

of soil to moisture is necessarily one of great moment. It is true that in some parts the superfluous water has to be led off the land, but this is done by carrying it in channels or by a system of embankments which prevent the rush of water over the surface, and the consequent washing away of the top soil; it is not done by any subsoil drainage system, so familiar to us in this country.

But the main problem in India is not how to remove the water, but how to bring it to the soil, and then how to keep it there. Indian soils are normally dry, English soils wet.

The mention of this naturally leads one to consider whether the native system of shallow-ploughing, or rather *scratching* the ground, is so very wrong as would-be improvers have made it out to be.

The action of the native plough resembles that of a pointed stick running just below the surface of the ground, some  $2\frac{1}{2}$  to 3 inches deep, and stirring the soil whilst it tears out and brings to the surface any infesting weed. Though there may be instances where deep-ploughing would be effectual, I believe that in the great majority of cases the native system of ploughing is the one best adapted to the conditions, and that, were a furrow-turning plough used, the result would be to lose a great deal of the precious moisture. Again, if the soil be at all stiff, the slice turned up by an English plough would speedily become baked in the hot sun and remain a brick rather than soil. The native ploughing, on the contrary, pulverises the soil, and the repeated going over the land, while it costs the cultivator no more (for the bullocks and the labour are his own), enables him to get that fine tilth which is essential to him, and thereby he does not lose the moisture. Frequently with a furrow-turning plough it would happen that weeds, instead of being torn out as they would be by the digging action of the native plough, would be buried, and there are many of these in India which would speedily spring up again and form a dense matting.

Of the soil-constituents it may be said that, while phosphoric acid, potash and lime are present in greater abundance in most Indian soils than in English ones, there is a marked deficiency both of vegetable matter and of nitrogen. Black cotton-soil has been referred to as a special feature, and it is popularly supposed to be of inexhaustible fertility. Other tracts there are which every year receive a fresh renewal of silt from rivers and mountain streams, and these in the Punjab constitute the rich wheat-growing areas which need no other manuring than what the silt affords. But there are other not so desirable effects

of river and flood, and often much land is cut up with ravines and rendered unculturable. Lastly, there is the singular appearance of a saline efflorescence known as *reh*, a mixture of various soda-salts, principally the carbonate and sulphate. In the North-West Provinces alone, between four and five thousand square miles are thus affected and rendered unproductive. Such land is termed *usar*. The singular point is that, amid these areas there are patches not only culturable, but on which some of the richest crops are grown. The problem of overcoming *usar* has long engaged the attention of Agricultural Departments. Canals are charged with bringing it, but it is clear that it is a saline deposit existing below the surface, which, under the combined influence of water and a strong evaporating force like the sun, is first dissolved and then brought to the surface, where the salts crystallise out and remain as a white incrustation.

A most interesting question, but one to which, at this stage, no definite reply can be given, arises, as to whether the soil of India is, under the system of agriculture pursued, undergoing exhaustion or not. The average yield of wheat, for example, may be set at about 12 bushels per acre over the whole country, as against the 30 bushels of England. A large proportion of this goes for export, and the increasing area under wheat shown in the agricultural returns denotes that this export is one that is likely to continue. The possibility of soil-exhaustion going on can only be determined by a careful study of what is removed from the land, and how far this is replaced either by the forces of nature or by the artificial replenishment of manuring. I have mentioned the deficiency of nitrogen which I observed in the case of several Indian soils, but it is worthy of note, too, how very large a proportion of the crops annually grown, also of the trees and shrubs, and even of the weeds, are leguminous in character, and may thus, if recent investigations be correct, possibly derive their nitrogen direct from the atmosphere.

Water, in its general bearing on the agriculture, has been referred to, but many pages might easily be occupied in describing the systems of canal irrigation, and the many ingenious devices which the native employs for lifting water on to his land, whether it be from canal, or reservoir, or from wells. All alike give rise to one marked distinction in the appearance of irrigated as compared with unirrigated, or, as it is termed, "dry" land. This consists in the dividing up of the irrigated patch or field into numerous little compartments by means of small mounds or embankments of earth some 5 or 6 inches high. This gives to the plot a honeycombed appearance, and the compartments are made to communicate with each other by

simply breaking down the dividing partition. Thus, by letting the water flow slowly, first into one compartment which is blocked off from the others, then breaking the partition and allowing the water to run into the next, the whole crop is gradually watered in turn, the cultivators meantime keeping up a regular flow along the main channel, be it from well, canal branch, or other source. This work, more especially in the case of irrigation from wells, is most admirably done, and the "garden land," as in the latter case it is called, presents some of the most splendid features of careful and high-class cultivation that one can possibly see in any part of the world.

It must not be supposed, however, that irrigation from wells is possible everywhere, for it is often the case that the water-level is too low to repay the labour of well construction, or, again, hard rock may intervene, or the water be brackish. This depends entirely upon the geological character of the district in question. It is quite possible, as *e.g.* in the case of the North-West Provinces, to find a successive series of zones running across the country, each one differing in respect of adaptability to this or that means of water-supply. First, there may be the zone where rainfall is abundant and neither canal nor well be needed; then one where the water-level is high and irrigation from wells may be a useful supplement; next a region where no canal comes and cultivation with wells is the only kind to depend upon; after that another where both canals and wells are present, and where both are needed, one to supplement the other; lastly, there may be a district where the water-level is so low that the digging of wells is impracticable, and dependence must be placed entirely upon a canal supply. It is to the extension of canals in districts such as the last named that the attention of Government and of the Irrigation Department in particular is rightly directed, inasmuch as the cultivation alters, and different crops are often grown according as canal or well irrigation is used.

This explanation shows the great variations that may be observed in the agriculture even within a moderate range, and that no one description can be made general in its application. In the alluvial Indo-Gangetic plain, as we pass from west to east we cross three tracts with quite distinct general features as regards irrigation: first, the Punjab, the country *par excellence* of canals; then the North-West Provinces and Oudh, where, as shown above, both wells and canals have their place; then Bengal, where for the most part both are unnecessary, and storage of rainfall takes place in surface reservoirs which dry up each year. On the black cotton-soil of Central India irrigation



is hardly, if at all, required, and embanking of land to hold the water up, and to prevent its washing the soil away, takes its place. Further south, on the rocky land, canals and channels again have their use, and storage of water is effected, not by shallow surface reservoirs as in Bengal, but by the digging of "tanks," as they are called, but which are really embanked lakes formed by intercepting watercourses. To the digging of wells, the formation of tanks and reservoirs and embanking of land, the Government gives encouragement through a system of advancing money at easy rates to the cultivators, and by deferring increased assessment for the improvements effected. This is known as the *taccavi* system.

The next point of striking importance in the external surroundings of agriculture is the supply of wood for timber and fuel, and the provision of grazing by means of those forests which still remain to the country. There can be little doubt that India in the past has suffered great detriment both as regards its climate and its agriculture by the reckless devastation of wood and forests which has until within recent years been allowed to go on unchecked. It is, therefore, a matter of much satisfaction that now, late though it be, the charge of the forests has been put under a responsible Department, and that they are being preserved for the benefit of the State and the welfare of the people. Not that the work is complete, nor that reservation of forest land has been effected without considerable friction from an increasing population which presses its cultivation up to the limits of the forest area in the endeavour to find room for itself. But it is equally certain that the Native, if left to himself, would as speedily exterminate what remains as he has done in the past, whether by wholesale clearance for cultivation, or by excessive grazing with cattle, and, worst of all, by the destructive herds of goats. Then, but only when too late, would the discovery be made how important is the relation which the forests bear to agriculture, and how essential to the latter the forests really are.

The spread of cultivation to the limits of the forests has altered in great measure the scope of the Forest Administration, which was at first non-agricultural and confined itself to the production of large timber. Now, however, the position is changed, and the Forest Department is recognising that the areas under its control must be more used in the direct interests of agriculture, and that, as far as possible, not only a timber supply for the great works of the country is needed, but also that the provision of wood for agricultural purposes, and for fuel, as also of fodder and pasturage for cattle, forms part of its duties. That

this is so is only fully understood when it is remembered what the *raiyat's* difficulties are in the way of providing fodder for his beasts, and when it is explained that, while the only really available source of manure is cattle-dung, this is largely burnt as fuel, and is thus lost to the land, simply because there is not a sufficiency of wood available to take its place. This agricultural loss might to a considerable extent be met by the extension of the wood-supply of the country, and steps in this direction are being taken both by the Forest Department and by the local authorities of towns. The importance of provision of pasturage and shelter for cattle in times of drought is very great, whilst in holding up the soil and preventing its denudation by the unbroken flow of water over its surface, the covering of the ground with trees and herbage has an indirect bearing upon the climate of the heated regions. In the course of a journey one frequently passes vast open but perfectly barren spaces over which large herds roam; these are not the *usar* plains referred to previously, but they are the "village wastes," the common property of the villagers, and melancholy examples do they afford of what the cultivators would, by excessive stocking and over-grazing, do with the rest of the land now under forest, were it left to their unchecked control.

I have briefly touched on the supply of manure to the land. Of this, as stated, the only really available source is the cattle-manure produced on the holdings, and of it a great part is lost owing to its being used as fuel in the absence of wood. In Indian agriculture manure by itself is not sufficient, water is needed along with it; nor is water by itself enough, manure must go with it; the two are in fact interdependent. Could the *raiyat* have both of these where there is need of them, he would be behind none in the results of his cultivating skill and diligence.

J. AUGUSTUS VOELCKER.

---

## ACIDITY IN MILK.

WHEN it is considered that directly milk passes from the udder of the cow it exhibits traces of acidity, that this acidity goes on steadily increasing the longer the milk is kept, and that it exercises a most important influence both on the value of the milk itself as an element of food and on its conversion into butter and cheese, it will be evident how essential it must be to the

proper conduct of dairying that those who have to handle milk should be able, not only to recognise the presence of acidity in it, but also to estimate with some approach to accuracy the *degree* of acidity which a given sample of milk or its products may have reached.

The chemist has for a long time been able to do this with as much precision as can be desired in any ordinary process of the kind ; but the application to dairy-work of the method which he employs, though simple enough in theory, involves practical obstacles of such a nature that in the difficulty which has been found hitherto in dealing with them must be sought the explanation of the fact, that although cheese-makers especially have for years past been appealing to the chemist for aid in helping them to determine the acidity of milk and whey, the chemist has hitherto, in this country at any rate,<sup>1</sup> made no response to their appeal. In the course of the experimental inquiries which the writer has for the last few years been carrying on in dairying, it became at an early stage evident to him that a mode of estimating acidity with fairly approximate accuracy was of the first importance ; and he has made a large number of experiments with the view of working out a process which, whilst accurate enough for practical purposes, should be so simple as to be usable by any person of ordinary intelligence. Before proceeding to describe the process itself and some of the results which are obtainable from it, it may be well to say a few words on the principles on which it is founded.

First, then, with reference to the measurement of acidity generally. If we take a vessel containing any acid liquid, such as vinegar, we can measure the *volume* of the vessel by means of a foot-rule ; we can also estimate its *weight* by putting it into the scales ; and we can determine its *temperature*, if we wish to do so, by means of the thermometer. But how are we to gauge its acidity ? We ordinarily test 'sourness' by the taste ; but a little reflection, or still better, a little experiment, will soon convince anyone who needs conviction that the sense of taste, like all the other senses, is liable to serious error, and that it is therefore quite incapable of giving information of any precision or trustworthiness. Most dairymen, however, who have any pretensions to a proper knowledge of their business are aware that better information as to acidity than the sense of taste or smell can give them may be obtained by the use of litmus-paper. If

---

<sup>1</sup> The process of acidimetry suggested in the following pages is similar in general details to that proposed by Soxhlet and Henkel, but the appliances employed by these authorities are far more complicated, and, in the writer's opinion, quite unsuited to ordinary dairy use.

a piece of blue litmus-paper is dipped into a sample even of fresh milk it gradually turns purple, and if the milk is stale the purple will change into a bright pink. By the rapidity with which this change takes place we may form a rough idea as to whether the milk is very acid or not, as we may do also by comparing the indication given by the milk with that given by vinegar. But even litmus-paper is insufficient, for want of delicacy, to indicate slight variations in acidity, or to give us any precise idea of the relative acidity of any two acid liquids which we may wish to compare with one another. For such a purpose we require a gauge, which we can apply to the acid liquid in the same way as we use a foot-rule to measure cubical capacity, or a balance to measure weight, or a thermometer to measure temperature. How is this to be obtained?

To construct such a gauge we have to take advantage of a chemical fact which is familiar to everyone, and that is, that the property of acidity which ordinary acid bodies possess can be neutralised and concealed by the addition to them of bodies of an antagonistic character, known as alkalies, such as common washing-soda. A fact which is not quite so familiar to those who have no knowledge of chemistry, but which a little simple experimentation will make very clear, is, that if we take a definite quantity of any acid liquid, say one ounce of pure vinegar, we shall find that, however often we repeat the experiment, it will always take exactly the same weight of any given sample of washing-soda to neutralise the acidity. Here, then, we have a basis for the construction of a gauge of acidity. For all that we have to do is to settle on a standard quantity of soda, and use it as a means of expressing the acidity of any liquid to which we may wish to apply it.

What we need for this purpose is a *unit weight*, just as we take the *inch* as the unit of *length* and the *degree* as the unit of *temperature*. We may, then, call the amount of acidity which our unit weight of alkali will exactly neutralise *one degree*; and it will be obvious that by thus taking as many unit weights of alkali as may be necessary to neutralise the acidity of a definite quantity of any acid liquid we can speak of its acidity as being 5, 10, or any other number of degrees, as the case may be. If we always use the same unit weight of alkali and the same bulk of liquid we shall be able to compare the acidities either of the same liquid at different times, or of different liquids, with the same ease and certainty that we can measure the contents of two different cans of milk, or estimate their temperatures at the same or at different times.

But, it may be asked, How are we to know when we have

neutralised the acidity of any given liquid? It will be obvious that the whole exactness of our gauge will depend upon this point; for if we add too much or too little alkali we shall introduce a source of error into our test which will vitiate it, and may make it practically useless. This difficulty is overcome by the adoption of a very simple device. Suppose that before adding an alkali to our acid liquid we place in the latter a piece of blue litmus-paper: the blue colour will, as before indicated, become changed into a red. Let us now cautiously add our alkali (to facilitate which we will dissolve it in water, so as to obtain a solution, which may be the more easily employed for neutralising purposes), and observe what takes place. At a certain stage of the operation the red colour of the litmus will begin to change into purple, and if more alkali is added the purple will pass again into the original blue. Here, then, in the stage which exists between the change of the red colour of the litmus into blue we have an indication of the stage of neutralisation; and the more this stage can be shortened the more exact the determination of the point of neutralisation will be.

From its property of thus indicating the point when neutralisation is reached in the mutual action of acids and alkalies on one another, litmus is technically called an *indicator*, and it belongs to a class of chemical agents all of which possess the property of being affected in the same way, and consequently of being available as indicators. Some of these bodies, unlike litmus, have no colour at all, except in the presence of either an acid or an alkali; and this is an advantage in an indicator, as it is much easier for the eye to recognise the change from *colour* to *no colour* than from one tint to another, especially when that change is from such a colour as blue to another colour like red, through all sorts of intermediate gradations of purple. Moreover, litmus is not nearly so sensitive in its reactions to acids and alkalies as some other indicators are. Amongst these is a body known as *phenolphthallein*, one of the numerous members of that most interesting group of chemical products, the derivatives of coal-tar. This substance, which when in solution gives a full purple colour in the presence of a most minute quantity of any alkali, loses that colour altogether when the alkali is neutralised by an acid; or, whilst in the presence of an acid it gives no colour at all, when the acid is neutralised by the addition of an alkali, the purple tint makes its appearance. By taking advantage, therefore, of these properties of this sensitive colour reagent, and adding a minute quantity of it to any acid solution, and then gradually adding to the mixture an alkaline solution until a

permanent purple colour is produced, we are enabled to recognise with ease the precise point when the acidity is perfectly neutralised.

Having thus arrived at a knowledge of *how* to measure acidity, it only remains to decide what *scale of measurement* we shall adopt for the purpose—that is to say, what unit of measurement we shall assume. Just as in measuring the size of a can of milk we take an *inch* for our unit, and as in estimating the temperature of the milk we take a *degree* on the thermometric scale, whatever that scale may be, as our unit of *temperature*, so in gauging the acidity of the milk we require to decide on some definite quantity of acidity which can be itself measured with certainty whenever we want to reproduce it, and in terms of which we can express or estimate the acidity of any given liquid. Now the *inch*, and also the *degree* of the ordinary thermometric scale used in this country (Fahrenheit's), are both of them arbitrary units; that is, they were originally adopted for reasons of practical convenience rather than to satisfy theoretical considerations. On the same grounds, for reasons which it is unnecessary to discuss here, the unit of acidity which the writer has adopted is one which he has found most convenient for the general objects which have to be kept in view in measuring acidity for dairy purposes. It is represented by an exceedingly minute weight of pure, dry, crystalline oxalic acid, an acid which is generally selected by the chemist for this purpose, because it can be easily obtained of uniform strength. It is simply necessary to make a solution containing a definite quantity of this acid, and then to make an alkaline solution which exactly equals it in strength, and we then know that every unit of the alkali represents one unit of our *normal* or standard acid; and if we can only measure that unit with ease and accuracy we have at our disposal a mode of measuring acidity which is, in theory, as exact and as reliable as the foot-rule or the thermometer, and is in every way comparable with them.

Now here comes in one of the practical difficulties of this question. It is very easy for the chemist to measure acidity in his laboratory, because he has not only the appliances and materials at his disposal for so doing, but the knowledge and skill which are necessary for using them, and for avoiding the fallacies into which an untrained person may easily fall in so doing. In order, in the first place, to meet the requirements of the problem, it is necessary to have as a neutraliser an alkaline solution of considerable strength, or otherwise the delicacy of the test would be proportionately impaired and its practical value in the same degree diminished. But, unfortunately, the alka-

line solutions which are best adapted for use as neutralisers, viz. caustic potash and soda, when exposed to the air become gradually weakened by absorption from it of carbonic acid, and the stronger these solutions are the more rapidly do they absorb this gas. This is, of course, fatal to their trustworthiness for measuring purposes, and they would be useless for such purposes unless they were protected from exposure to the air. In the laboratory this is easily effected by the use of devices which present no difficulty to those who are accustomed to handle delicate apparatus, and who can easily satisfy themselves whether from any accident the neutraliser solution has undergone deterioration. But for the comparatively rough purposes of the dairy, and for use by operators who would, in most cases, have had little or no training in the employment of such resources, appliances of this type would be altogether unsuitable.

Hence the problem further resolves itself into devising an arrangement in which a solution of a caustic alkali, of such strength as to be sufficiently delicate for practical requirements, can be kept with so little exposure to the air as not to materially affect the uniformity of the results which it will give. This arrangement must be of such a kind that a measured quantity can be easily drawn from it; and it must be, further, sufficiently simple to enable any person of ordinary intelligence to use it without risk of serious error; sufficiently strong to prevent it from being easily broken; and sufficiently cheap to make its cost no reasonable ground of objection.

Having thus endeavoured to explain the principles on which the *method* of measuring acidity is based, and the conditions which have to be satisfied in order to make it available for ordinary dairy requirements, it only remains to describe the specific form and strength of neutralising solution, and also the unit of measurement which the writer has adopted. The *Neutraliser* is a solution of potassium hydrate (caustic potash) of such a strength that one unit volume exactly neutralises one volume of a solution of 7.875 grammes of pure, dry, crystallized oxalic acid in one litre of water. This solution of oxalic acid is exactly one-eighth the strength of the *normal* solution as employed for ordinary laboratory purposes, and it has been adopted because it has been found by a good deal of practical experimentation to represent an alkaline solution of convenient strength for general dairy work. A higher or a lower standard of alkalinity might be employed without affecting the principle of the test; but either step is attended with disadvantages, which increase in proportion as we diverge from the standard above indicated.

A more important consideration is the unit to be adopted

for measuring the *Neutraliser* and the means by which the process of measuring is to be effected. After a great deal of experimentation it has been decided to adopt the drop as the simplest form of unit, and one which can be measured with sufficient precision for the purpose in view, provided certain simple precautions are observed. Those precautions are the use of a dropper with an outlet of standard size, and the regulation of the rate of dropping to *about* one drop per second.<sup>1</sup> The latter condition can be easily observed by anyone of ordinary intelligence; the former is satisfied by always using the same dropper. With the view of providing a dropper which may be used by various persons so as to give comparable results, the writer has adopted a nickel-plated brass tube having an external diameter of 17 B.W.G. (Birmingham Wire Gauge), as being as convenient as any for the purpose. And in order to allow of the neutralising solution being employed in the simplest possible way, a glass pipette, having a section of the above tubing attached to one end and an indiarubber capsule at the other, by pressure on which the pipette can be filled or emptied, has also been adopted.

But the most difficult element of the problem was to devise a receptacle for the *Neutraliser* in which it could be kept without exposure to the air, and from which it could be extracted so as to be measured in drops. Various forms of burette and drop-bottle have been tried, but all of them were found to be open to objections of one kind or another, from which the writer believes that a simple device which suggested itself to him is free. This consists in fixing what may be called a glass well-tube in an air-tight manner in the neck of the bottle holding the *Neutraliser*, in such a way that the bottom of the tube nearly reaches to the bottom of the bottle, and is constricted to such an extent that the metallic tube of the dropper just fits into it and projects for about half an inch below, when the dropper rests in the well-tube. By this device no air can enter the bottle except to supply the place of the solution as it is drawn off, and thus the total volume of air which can come into contact with the solution, so long as the well-tube is kept fixed in the neck of the bottle, is limited to the cubic capacity of the bottle itself; and this limit can, obviously, only be reached when the solution is quite exhausted. The amount of error which

---

<sup>1</sup> The variations in weight of water dropped from the same outlet as quickly and as slowly as possible may amount to nearly ten per cent., but a slight variation from the rate above indicated produces such a trifling error that it may be disregarded.



may thus be introduced into the test is, even at its maximum, so small that it may be disregarded. The error which may be introduced from continuous exposure of the small area of the liquid corresponding with the hole at the bottom of the well-tube is also so slight that it has no appreciable effect on the strength of the solution during any reasonable period, especially as this hole is filled by the dropper when the appliance is not in use.

The only other element of the arrangement that has to be noticed is the quantity of the liquid to be tested which is taken for a sample. For reasons of a technical kind, connected with the production of the appliance in a cheap and simple form, which it is unnecessary to explain here, the quantity adopted for the purpose is three cubic centimetres, which gives a bulk that is neither too large nor too small; and this quantity is easily taken from the gross bulk of the liquid to be tested by means of a glass sampling tube, with a rubber capsule at one end, and a mark on the tube to indicate the precise amount to be taken by it.

The general nature of the appliances thus described will be better understood by reference to the accompanying wood-cut, which represents the bottle of the *Neutraliser* with the dropping-tube resting in the well-tube, and on either side the dropping-tube itself, and the sampling tube.

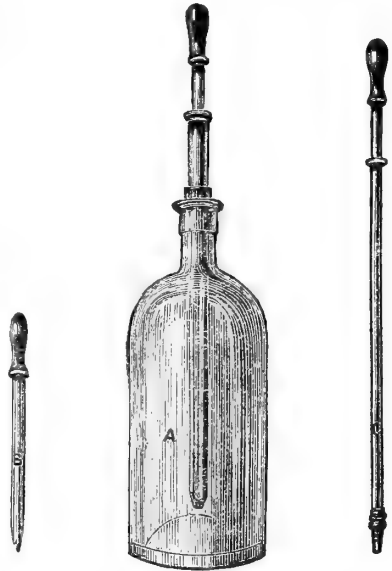

A very few words will suffice to explain the proceeding involved in making the test itself. The end of the sampling-tube is inserted in the liquid to be tested, say milk; the rubber capsule is compressed between the finger and thumb, and by this means the proper quantity of the milk is taken up in the tube, and is then squeezed out into a small glass or cup. In the same way a charge of the *Neutraliser* is taken by means of the dropping-tube and dropped into the milk, to which a minute quantity of the *Indicator* has been added, until a permanent

purple colour has been produced. The number of drops required for this purpose gives the number of *degrees of acidity* which the milk possesses.

It is only possible here to add a few words in illustration of the information which the test as thus made is calculated to give, and of the conditions under which acidity is developed in milk and its products.

If a sample of milk that has stood for a few hours in a warm place be examined by the test above described, it will be found to exhibit an acidity which may vary from 4 to 6 or 7 degrees. This acidity will be due to two distinct bodies: to lactic acid and acid salts (chiefly acid phosphates), and to carbonic acid. The former of these compounds, which may be called the *fixed* acidity, is due to the fermentation of the sugar present in the milk, and to its conversion into *lactic acid*. This acid in its turn acts upon the basic salts of the milk (alkaline and earthy phosphates), and converts them into acid salts. The carbonic acid, which may be called the *volatile* ingredient of the acidity, is produced by a further breaking up of the lactic acid. The two together make up the *total* acidity.

It is this total acidity which is determined by the test which has been above described, and it is very questionable whether any advantage is to be obtained by a separate determination of its two component parts, inasmuch as the principal effect which the development of acidity has on the milk, viz. that of rendering the casein insoluble, is produced by carbonic acid as well as by lactic acid, though, as might be supposed, from the difference in the relative intensities of these two acids, with different degrees of energy. The relative feebleness of free carbonic acid makes it much more difficult to determine with precision the amount of it which may be present in any given liquid; but a fair approximation to it may be made by using an alcoholic solution of alizarin as an indicator instead of a solution of phenolphthallein, as above described. The latter of these two reagents is affected by free carbonic acid, as it is by all other free acids or acid salts of any energy; the purple colour of an alkalisied solution being equally discharged. But the action of alizarin is different. If a drop or two of this reagent be added to a solution such as whey, the acidity of which is due to the presence of free carbonic and lactic acids as well as acid salts, a bright yellow colour is communicated to the solution. If now the acidity is gradually neutralised by an alkali a point will be reached when the yellow tint passes through an intermediate brownish tint into purple. This transition indicates the stage of neutralisation of that portion of the acidity which is caused by the lactic acid and acid

phosphates, for free carbonic acid has very slight, if any, effect on the colour of alizarin, and the alkali therefore produces its full effect directly this stage has been reached.

To take an illustration which will show the application of the test in its most marked form: A sample of whey which has been bottled and allowed to ferment under pressure, may, when uncorked, and when active effervescence has ceased, show, with phenolphthallein as an *indicator*, as much as 80 degrees of acidity. But, with alizarin, the acidity registered would be only from 30 to 40 degrees; thus demonstrating that the *volatile* acidity, due to the presence of carbonic acid, may under such conditions amount to nearly as much as the *fixed* acidity, caused by lactic acid and the acid phosphates. Indeed 40 degrees is the highest amount of acidity in whey due to fixed acid which the writer has ever observed; when that amount of acidity is reached the further generation of lactic acid is arrested, unless the free acid be neutralised by an alkali or an alkaline earth, as is done in the process for manufacturing the acid for commercial purposes.

The acidity of perfectly fresh milk may be as low as zero. Indeed in cases of local or constitutional disease the reaction of the milk may be distinctly alkaline. Such milk is absolutely unfit for cheese-making, as it rapidly undergoes the butyric fermentation, amongst the products of which are hydrogen and carbonic acid; and this leads to the permeation of the cheese by these gases, with the results, so well known to cheese-makers, of "heaving," "puffing," &c. Hence the great importance to the cheese-maker of being able to estimate the acidity of the milk which he employs, for if he finds it deficient in acidity he has the indication to push on the development of acidity, which he may do in several ways.

The amount of acidity which milk should possess for cheese-making varies from three to seven degrees, according to the time of year. In the spring, when the cows are feeding principally on the abundant herbage of early pastures, the casein of the milk will be deficient in tenacity, and a higher degree of acidity will be desirable in the milk than in the summer and autumn, when, from the grasses being seeding and the pasture comparatively dry, the tenacity of the casein will be much higher. Without the means of accurately measuring the acidity of milk in this respect, the work of the cheese-maker is mere blind empiricism; but with the aid of the acidometer he has the whole process under complete control.

A great deal of loose and inaccurate talk is often to be heard amongst so-called "practical" cheese-makers about the importance of getting the curd out of the whey before acidity is deve-

loped. As a matter of fact the progress of acidification in the cheese-vat *before* the whey is drawn off is very slow. Indeed, the degree of acidity shown by the whey at the stage when it is drawn off in the ordinary routine of the Cheddar process will be sometimes absolutely less than that of the milk before the rennet was added to it. This apparent paradox is partly due to the fact that the observation of the change of colour produced by the addition of the Indicator is more easily perceived in a transparent fluid like whey than it is in an opaque one like milk; and the eye therefore recognises the passage of the stage of neutralisation more readily in the former case than in the latter; leading to the impression of a lower grade of acidity in the whey than was exhibited by the milk.

The real rise of acidity in cheese-making does not take place until the curd is exposed to the action of the air, as in the process of cutting and piling. Then the free access of oxygen allows of the rapid development of lactic acid, and the acidity may in the course of an hour or less rise from five to twelve or fourteen degrees.

The development of acidity in cream during the progress of ripening may be easily traced by the acidometer. Here the total acidity is materially augmented by the retention of carbonic acid in the viscous fluid, and may rise to as much as sixteen degrees before the cream becomes thoroughly clotted by curding. This viscosity of cream, which interferes somewhat with the delicacy of the acidometric test, may be counteracted by diluting the cream with a given amount of water, and multiplying the degree of acidity obtained in proportion to the volume of water which has been used.

The acidometer is of great value in determining the stage to which a given sample of milk may have advanced in the process of spontaneous acidification. As the curding of milk is entirely due to the effect of the acid in neutralising the alkaline phosphates by which the casein of the milk is retained in its viscous condition, it is easy to satisfy oneself by the aid of the appliance how far any given sample of milk has progressed in this direction.

In fact, no one who handles milk, for whatever purpose, can do so with any certainty of what he is about unless he can estimate its acidity, and this it is now possible to do with as much ease and certainty as its temperature can be gauged by the thermometer or its weight determined by the balance.

FRANCIS T. BOND.

---

## FARM POULTRY.

FORTY years ago the Royal Agricultural Society offered a prize for the best essay on the rearing and management of farm poultry. This was awarded to Mr. William Trotter, of Healey Mill, Hexham, for a very practical and useful article on the subject. Since the date of its publication a great impetus has been given to poultry keeping, by the establishment of competitive shows for fancy varieties. At these shows, however, useful properties have been almost entirely ignored, and prizes have been awarded for accuracy of marking in feather, symmetry of comb, and other fancy points having no reference whatever to the value of fowls as market or table poultry, or as egg-producers. In fact, it is hardly too strong an assertion to maintain that every breed which has become a fancy or show variety has been deteriorated in practical value. The produce of eggs in particular has been utterly neglected, and many of the breeds which, before the era of poultry shows, were valued as large egg-producers, are now almost useless in that particular.

Half a century since, Spanish fowls were commonly seen in many of the large stable and fannyards about London, being kept solely for their abundant production of large white eggs. They are now known as the worst layers of any non-incubating variety, and some of the hens that have figured largely as prize-winners have never laid an egg. Amongst the incubating breeds Cochins were at one time regarded as the most prolific layers, being absolutely credited by some with the faculty of laying two or even three eggs per day. For the last forty years they have been bred solely for feather, and the result is that this breed, once possessed of certain useful properties, is now valueless except as a fancy fowl. Its introduction into our poultry yards has in fact done more harm than good to our native breeds, inasmuch as, while it has lost its own prolificacy, its deficiency of flesh upon the breast has tended considerably to depreciate the value of our table poultry with which it has been crossed.

Since the introduction of fancy poultry the importation of eggs, more especially from France, has gone on increasing to an enormous extent, a fact which some persons seek to account for by the supposition of the existence of large and extensive poultry farms in France. This belief is so thoroughly grounded in the mind of the public, that scarcely a year passes but poultry farms are started. These generally last but for a couple of

seasons, at the end of which time the capital of the founders is exhausted, and all the plant and what remains of the stock is distributed by the hammer of the auctioneer.

Poultry farms have been tried in England under every variety of condition. Large portions of land have been devoted to their service, and have in some cases been gratuitously given for the purpose. In others extensive ranges of buildings have been erected according to various plans, but in every instance the result has been the same—disastrous pecuniary failure. Numerous accounts of supposititious poultry farms in France have appeared in English journals; but they have had no existence except in imagination. Mr. Charles L. Sutherland, one of the Assistant Commissioners of the Royal Commission on Agriculture, devoted special attention to the subject in 1879 in the course of his investigation into the agricultural conditions of West Central France, and he thus describes the result of his inquiries:—<sup>1</sup>

It is a commonly received idea in England that there exist in France huge poultry farms, where fowls are kept by several hundreds, and it has been over and over again urged on English farmers to adopt this poultry farming on a gigantic scale, as some sort of means of alleviating the present depression and enabling them to make money. A long acquaintance with the chief French poultry-breeding districts, as well as answers to inquiries I have from time to time made on the subject, enable me positively to deny the existence of such establishments. The greatest number of heads of poultry that can be kept profitably on a single farm varies from 200 to 300. If a greater number than this is kept the ground becomes poisoned, and it is found impossible to rear chickens. Whenever large poultry farms have been started in England, as, for instance, at Bromley in Kent, they have failed, and chiefly owing to the above reason—a reason perfectly well known to and understood by all practical poultry keepers. The manner in which so many fowls are reared and eggs produced in France is as follows, independently, of course, of climatic influences, which must be held to be of some little account. Every peasant proprietor, every *bordier*, with perhaps two or three acres of land, keeps fowls, the produce from which is collected by dealers who scour the country. In this way a very large number of fowls in the aggregate is kept, but they are scattered about all over the country; and so well is the necessity for change of ground understood in the districts where poultry rearing is a special industry, that great sacrifices are made by the breeders to secure fresh ground on which to rear their chickens.

There can be no doubt that poultry could be much more extensively and profitably reared by the small farmers and cottagers in our own country than is now the case, and far better table fowl could be produced. The great drawbacks to the profitable keeping of poultry are identical with those alluded to by Mr. Whithead in his valuable *Hints on Vegetable and Fruit*

<sup>1</sup> *Reports of the Royal Commission on Agriculture*, Appendix to Part I. p. 816 (Parl. Paper, C. 2778, II). Quoted in *Journal*, Vol. XIX. (Second Series), p. 190.

*Farming*, issued by the Royal Agricultural Society. These he states to be "the excessively high rates charged by the railway companies for the carriage of produce, and the unsatisfactory modes of distribution. In the existing circumstances the producers get the minimum value, while the consumers have to pay the maximum price. The pernicious system of salesmen and middlemen, and the routine of markets, hinder enterprise and check production." If poultry are consigned to the markets, the producer has no check whatever on the middleman, and whatever the price to the consumer may be, he gets a very inadequate return. But in spite of these drawbacks it is believed that the cultivation of poultry may be largely and profitably extended, if it be conducted in accordance with profitable rather than fancy considerations.

#### FOWLS.

The first point to be considered in the keeping of poultry is the accommodation that can be afforded them. The practice of allowing fowls to roost in the trees, though very conducive to their health and high condition, is one that is obviously rarely practicable; but with regard to a house no particular form or character is necessary. Stalls of an unused stable or any ordinary shed can with little or no expense be converted into a poultry house as advantageous as the most expensive. The arrangements in ordinary houses are eminently unsatisfactory. Usually perches are made one higher than the other, the top-most being near the roof; the result is a twofold injury. Fowls retain their original instinct of roosting high up in trees, remote from their enemies. Consequently all ascend to the highest perch, fight for places, knock one another down, and, as they fall perpendicularly, injure and frequently break the keel of the breast-bone. When descending from the trees in the open, the fowl has the power of flying a long distance, and comes to the ground gradually. When dropping from a high perch in a confined building it comes with violence on the ground, strikes the feet against the floor, which in heavy birds induces "bumble feet," and is also apt to break the breast-bone.

These evils may be avoided by putting all the perches on one level, about three or four feet from the ground, when there will be no quarrelling for places, and the fowls can be caught when required with much greater facility. In this case, there

---

<sup>1</sup> *Hints on Vegetable and Fruit Farming.* By Charles Whitehead, F.L.S., F.G.S. Third Edition, 1890. John Murray. Price 6d.

must be no access to high rafters or cross-beams, up to which the fowls can fly. The nest-boxes which are to be seen in country poultry houses are usually placed in rows on shelves, which are sometimes in tiers, one above the other. No arrangement can be imagined better calculated to ensure the injurious dryness of the eggs, and to favour the generation of vermin which infest the sitting hens and nests.

The nests, in accordance with nature, should be on the damp ground, so that the eggs may be cooler below than above. A bushel of mould, or a thick green turf kept in its place by two or three bricks, makes the most efficient and healthy nest. They may also be made in boxes, or in old market baskets filled with moist earth. These can be covered over with an ordinary circular coop, so that the sitting hen is not molested by the others. If a hen lays away, stealing a nest in a hedge or under a corn stack, or any other obscure situation, the eggs should never be touched, if chickens are desired; as soon as the hen has laid her full clutch she will sit, and bring out a far stronger and healthier brood than will be produced under any more artificial circumstances. The exposure of the eggs to the weather does not, as many persons imagine, injure them in the slightest degree, for when a hen sits under these circumstances she usually hatches every egg.

If only one place can be devoted to both the hatching and laying fowls, it is necessary to divide the former from the latter by a piece of wire-work. For, if the laying hens are allowed to intrude upon those that are hatching, fighting—tending to a great destruction of eggs—ensues. Where it is practicable, it is always exceedingly desirable to sit two or three hens on the same day. When they have sat a week the eggs should be tested, and those which are not fertile removed. Many instruments under various names have been devised for this object, but none of them are superior to a piece of stiff cardboard, as the cover of a book, having an oval hole cut in it slightly smaller than the eggs to be examined. This is readily used with an ordinary lamp at night. The eggs should be carefully removed from under one of the hens, taken to a dark room and then examined. The cardboard is held upright between the eye and the light, and the egg is placed against the hole. If the light shines through it and it is clear, having the same appearance as a new-laid egg, it is not fertile, and it is worse than useless to replace it under the hen, as it occupies space and is liable to be broken and soil the other eggs. Those eggs that are fertile and contain chickens are perfectly dark and opaque, except at the larger end, where the air space is to be seen.



When two or three hens are set upon the same day and the eggs are examined at the end of a week, the clear ones being removed, it frequently happens that a sufficient number are taken away to enable the eggs of two hens to be given to one, or the eggs of three hens to be given to two, when a fresh sitting can be given to the hen that has been deprived of her batch. The eggs should hatch at the expiration of three weeks, viz., on the twenty-first day. The less interference that takes place at this time the better. Occasionally the life of a weakly chicken unable to get out of the shell may be saved by assisting it, but there is no doubt that more chickens are destroyed by interfering with the sitting hen on the twenty-first day than are saved by any assistance rendered. The hens should be left in the nest until the next day, when the young chicken will be strong, dry and active. The hen should then be put under a coop with her brood: if possible in a sunny place, as under a south wall.

The first food for the chicken should be egg and milk (the clear eggs removed from the hens answer admirably for this purpose). Each egg should be beaten up with a couple of tablespoonfuls of milk, and set into a custard-like mass by the side of the fire or in the oven. This should not be given to the chickens until the hen has been abundantly fed with corn and has satisfied her own hunger. For other food I much prefer to use a little canary-seed or Egyptian dari to crushed grits, which are apt to become rancid from the external covering having been removed. Bread and milk can also be given to the chicks, and sweet meal and milk; but much loss in rearing chickens occurs by the use of old meal which has been exposed to the air after grinding, and has become pungent and acrid.

The practice of cooping hens and chickens, though in many cases indispensably necessary, cannot but be regarded as an evil. The hens have no power to scratch for worms and grubs, which form the natural and by far the most advantageous food for the young. The chicks again are fed day after day in the same place, and constantly pick up food contaminated by their own dung, a practice which is certain to induce disease.

It is often alleged that hens allowed at large with young broods wander so much as to "drag them to death." This however is only the case when the hen is not well fed and she has to seek for food for herself as well as worms for her chickens. In health and vigour no chicken can compete with those that are produced by a hen who steals a nest under a hedge, and brings out a clutch of strong robust chickens, with which she returns to the homestead when they are two or three days old.

If chickens must be confined, it is much better to put each coop into a temporary run made by unrolling a coil of wire-work; this can be shifted every day on to fresh ground, a proceeding of very great advantage. Under these conditions the chickens are out in the early morning sun, instead of being shut up in the close air of a fowl-coop for some hours after they are awake, as is usually the case where the hen is confined.

The practice of tethering hens by one leg, which is frequently adopted by gamekeepers who rear pheasants, is one that may advantageously be introduced into poultry keeping. At the present time the custom is largely followed of giving chickens artificial food, which is often of very highly spiced and stimulating character. In my opinion no practice can be more objectionable. No dried animal food can equal the natural diet obtained by the hen for her chicks if she is allowed liberty, and highly spiced substances are neither natural nor desirable as food for chickens. The utilisation of the waste house scraps is most valuable. Bread soaked in milk, potatoes from the table, &c., and very small quantities of meat may be given. Care should be taken not to give fowls at any age too much animal fat; this is especially important as regards laying hens.

The temporary runs that I have recommended can be placed anywhere about the farm buildings, or still more advantageously in a garden where the young chickens can wander at will, and find much wholesome food without doing any damage. An orchard is also an exceedingly useful place for the coops or runs, as well as for the older fowls. The advantage of placing fowls in an orchard is twofold. They destroy large numbers of injurious insects, and at the same time fertilise the ground with their droppings. If an orchard is divided into two parts, one of which is used for fowl keeping and the other not, it will be found that the former is much more productive than the latter, the circumstances being equal. The late Mr. Mechi, of Tiptree Hall, used to allow his fowls to roam freely in his cornfields, and he always maintained that they did so with great advantage to themselves and with no injury to the corn.

In determining the most profitable breeds for a small farmer or cottage proprietor, we have first of all to consider whether eggs or market poultry are the more important consideration. In some places eggs pay much better than table fowls, and in others the reverse. If eggs are wanted, a non-incubating breed should be kept, as these lay a much larger number of eggs than hens that habitually sit. Formerly Spanish were largely used for this purpose, but their value, as before stated, has been utterly destroyed by their being solely cultivated as white-faced

fancy fowls. The common black Mediterranean breed, known as Minorcas, are amongst the very best layers at the present time, provided that ordinary farm-yard specimens and not show breeds, bred solely for size and regularity of comb, are selected. Leghorns, or a somewhat similar breed, have been, since their first introduction from America by myself in 1868, so closely interbred and shown as fancy fowls, that their size and vigour have much deteriorated. Their general colour is white, but recently they have been crossed with game fowls, to produce what are called Brown and Pile Leghorns, by which their vigour has been considerably increased. Andalusians, birds of the Spanish type, are also good layers, but they are now bred more exclusively for fancy marking than for profitable considerations. Spangled Hamburgs, or so-called pheasant fowls of the North of England, were formerly most profitable layers, but they also have been so exclusively bred for feather, that their valuable properties have been greatly lessened.

On the whole, I should be inclined to recommend ordinary farm-yard black Minorcas as the best breed that a small farmer can have, if the production of large white eggs is desired. I am sure, however, that no breed of fowls in existence will produce on the average anything like the number of eggs which is sometimes stated as a common result. If a farmer can obtain an average of one hundred and fifty eggs per annum from his stock, he may consider himself to have done very well. In many localities, as near towns and other populous places, it will be found desirable to use every effort to obtain new-laid eggs in the early part of the year, when they often fetch very high prices. For this purpose reliance must be placed on early hatched chickens, as the May broods do not lay freely in the cold weather.

When birds are required for market or the table, Mediterranean breeds, such as Andalusians, Minorcas, and Leghorns, are of very small value, not carrying much meat on the breast or being capable of furnishing plump and saleable chickens. For table poultry, Dorkings have a very great reputation, but the markets of London are chiefly supplied with what are known as Surrey fowls, which have been derived from the old-fashioned Dorkings that existed before the time of competitive shows. The modern show Dorking derived its greatly increased size from being crossed with the Malay breed, and what it gained in size it lost in quality and plumpness. It has also the disadvantage of being delicate. These defects may be removed by judicious crossing, and there is no doubt that the best table fowls at present produced in this country are those

resulting from crossing the Dorking either with the old-fashioned English game or the Indian game. By these means a hardy, early matured, very plump breed is produced, and at the shows of dead poultry these birds have always proved superior to others put into competition with them. I have never, under any circumstances, not even in the shows of fattened dead poultry that take place in Paris, seen better specimens of large plump table fowls of the highest quality, than those that were exhibited as the result of this crossing at the last Dairy Show held at the Agricultural Hall.

The Azeel, or Indian fighting cock, is an extraordinarily, plump, close-feathered, and heavy bird, and also crosses excellently with the Dorking or Surrey fowl; but it has two disadvantages—it is rather small, and of such exceedingly combative propensity that it is difficult to manage. Moreover, the hens are very indifferent layers, usually wanting to sit after laying ten or a dozen eggs. The crosses between the Indian game or the old-fashioned English game and Surrey or farm-yard fowls are, on the other hand, as good layers as any variety of fowl that habitually sit. There is a preference in this country for table fowls with white legs; although a most absurd one, it must not be omitted from consideration when breeding for the table, as to some extent at least it affects the price of market chickens.

I have not thought it necessary to mention particularly other crosses and other breeds of poultry as market fowl. Many farmers have sought to increase the size and value of their fowls by crossing with some of the Asiatic varieties, such as Cochins, Brahmas, Langshans, &c. It is quite true that size can be gained in this manner, but as the cross-bred birds are deficient in the amount of flesh on the breast, and carry a great deal of offal in the shape of heavy coarse bones and useless feathers, the proceeding is not desirable. Crosses of this kind have found no favour in the eyes of our more practical neighbours, the French, nor are the birds appreciated by the feeders, who buy for the purpose of fattening for the market. There has been a run recently on a cross-bred breed, manufactured some few years since in America, and known as Plymouth Rocks. These being hardy fowls, and for sitters abundant layers, they met with considerable favour in this country, especially as their well-marked plumage allowed them to be exhibited as fancy fowl. Their yellow skin and want of quality and plumpness render them however not adapted for market fowl in England. In America, where a good roast fowl is a rarity, chickens are mostly used as "broilers" when young, being split down the back and

cooked on a gridiron, when the bright yellow skin of the Plymouth Rock is not objectionable. At present the fashion in fancy poultry has tended in favour of a handsomely feathered breed, termed Wyandottes, and the Plymouth Rocks are going out of fashion. As Wyandottes have been reared exclusively for feather marking, they are, as might be expected, destitute of any merit as market fowls.

It may be asked what course should be recommended to a small farmer, who has a stock of fowls and wishes to improve them, with the view of producing good birds for the table. In many cases it would not be desirable to dispose of present stock and buy an entirely new one. The plan would be expensive, to commence with, and there might be a difficulty at the present time in getting really good birds for useful purposes. Birds that are now advertised and sold are in nine cases out of ten fancy birds, that have not been bred with any idea of their economical value. I should be disposed to recommend a small proprietor to carefully look over his stock; to get rid of all the small, weakly, undersized birds; to allow no pet fowls to remain, only those that are really the best of the stock; and then, getting rid of all male birds, to place in his yard a good close-feathered, short-legged Dorking or Surrey cock. At the end of the year this bird should be at once got rid of—killed and eaten, if it cannot be sold. The following year the best of the large pullets only should be allowed to remain. The cross-breed cockerels having been disposed of, a good heavy, short-legged, Indian or old-fashioned English game, should be obtained as the stock-bird for the season. Each year in succession a new stock-bird should be got, either Dorking, English, or Indian game. For it is the constant interbreeding which takes place in most farmyards that leads to the great deterioration of the size, condition, and constitution of the poultry.

As none of the half-bred cocks are to be kept, it is desirable to sell them as early as possible. They realise more money when young, and should be prepared for the table or market at once. The best mode of doing this, although it is not always in the power of the small farmer, is to take the cockerels away before they attain maturity, as soon as the combs begin to shoot and before the curved tail feathers can be seen. If they can be placed together in a run far removed from any hens, they will grow into large size without losing quality as table fowl: whereas, if they are allowed to run with the other fowls, they are continually chasing them and quarrelling among themselves. They cease to gain in weight and lose very much in condition, the flesh becoming hard. But this separation of the sexes in

chickens intended for the table is only practicable in farms of some considerable size. In every case it will be found desirable to sell off the cockerels, and those pullets that it is not desired to keep for stock, at an early period of their lives, or else to put them up to fatten in the ordinary manner. If fattened in coops, the cockerels should be shut up as soon as the central tail feathers are noticed as curving over the others, and they should be fed upon meal and milk until they have obtained the desired fatness.

Fowls cannot, however, be fatted without care and attention. They should be shut up in coops raised from the ground on legs, the bottom bars being about an inch and a half apart, so as to ensure cleanliness. Not more than a dozen fowls at a time should be put up together in one coop. In front a wedge-shaped trough should be placed. This should be filled three times a day with coarse fresh oatmeal mixed with milk. No more food should be given at once than will be eaten up at the time, before a fresh meal is given. The troughs should be kept thoroughly clean. It is best to have two sets, so that each can be scalded with boiling water every other day after use. At one end of the coop water should be given, and on the ledge supporting the trough a small supply of fresh clean gravel; a green turf may occasionally be put in the coop.

It is necessary to give these fatted fowls their first meal in the morning, at sunrise. If this meal is delayed until about eight o'clock, the fowls have been hungry and restless for hours, during which time the fat of the previous day has been wasted in useless exercise. About a fortnight is generally sufficient to fatten fowls, if these precautions are attended to. If the fowls are wanted fatter, they may be kept up a week longer, during which time they may be given a little hard mutton fat, such as the parings of the loin, which may be put in the scalding milk with which the oatmeal is mixed.

If fowls are wanted exceedingly fat, they must be crammed. On a large scale this is done by the aid of a cramming machine, of which Hearson's is the best that I have seen, but a small number may be crammed by hand, selecting those that have been put up to fat for a fortnight. In cramming, the oatmeal is mixed with boiling milk (to which a little mutton fat may be added, if thought desirable), sufficiently stiff to roll into sausage-shaped masses about two inches long and the size of the finger. Each fowl is taken out in succession, held in the lap, the beak kept open with the thumb and finger of the left hand; the sausage-shaped mass of meal should be dipped into milk, and placed at the back of the throat and pushed down

with the finger, the head being extended. About six or eight of these crams are given two or three times a day to each fowl, care being taken to ascertain that the previous meal has entirely passed out of the crop before another is given. Should it not have done so, the beak should be opened and some warm milk poured down the throat. The fowls thus fattened are usually spoken of in the London market as Surrey capons, but the term is incorrect, as very few of them have been operated on, nor is the operation necessary. If the fowls are killed as described, after sixteen hours' abstinence from food, it is not desirable to draw them before sending them to market, as they keep much better when not drawn, and consequently realise higher prices.

No fowl should be killed until it has fasted fourteen to sixteen hours. Those birds that it is intended to kill early in the morning should have both food and water taken away not later than four or five o'clock the afternoon before. If this is not done, and they are killed full of food, it soon decomposes, turns the birds green, and renders them comparatively worthless. Even if the food has passed out of the crop into the bowels, the fowls will not keep long, as the half-digested food in the interior causes them to spoil, and gives them an exceedingly unpleasant flavour.

With regard to the mode of killing fowls intended for sale, the almost universal practice in England is to break their necks. This should be done by seizing the legs of the fowl in the left hand and the head in the right, the back of the bird being upwards, and the comb in the hollow of the hand. If the legs of the birds are then held against the left hip and the head against the right thigh near the knee, by strongly extending the fowl, and at the same time bending the head suddenly backwards, the latter is dislocated from the top of the neck, and death results instantaneously, all the large vessels being torn across and the blood escaping into the skin of the neck. Muscular contractions, however, remain for some minutes, during which time the fowl, if put down, knocks itself about, bruising the flesh; it should therefore be held in the hand or hung up by a string round the legs to a hook in the ceiling. The fowl having been killed should be plucked whilst warm; in fact the professional killers proceed to remove the feathers immediately after dislocating the neck, as they then come out very easily and the skin does not tear. There is no cruelty in doing this, even if it be before the muscular contractions have ceased, as the head of the fowl is removed from the body, being connected only by the skin, and all sensation is at an end. When carefully plucked the fowls should be placed on their backs, the

hocks being tied together, the wings twisted behind the back, and the neck allowed to hang down so that the fluid blood accumulates in it. Under no circumstances should the breast-bone be broken, as it deteriorates very much the value of the fowl. It is needless to say that the legs and feet, if they are soiled, should be washed before the birds are sent to market.

The question may be asked whether it is most profitable to sell fowls from the yard or after being fatted. It depends entirely upon the mode in which they are kept, and the local character of the demand. If fowls are well fed in the runs, more especially when the young cocks are kept separate from the hens, they are in the finest possible condition for the table, and the expense and trouble of cooping and fattening are saved; but if they are not highly fed, and if both sexes are allowed to run together, the flesh of the birds soon becomes hard and the quality inferior. Another precaution should be taken: it is the custom of many persons to use maize for the feeding of poultry. This contains a very large percentage of yellow oil, and when given to fowls in quantity it accumulates under the skin, rendering them of a yellow colour, and consequently less saleable than they otherwise would be. There can be no doubt that the best food for making the flesh of fowls white and firm is that used in France, namely, buckwheat meal with milk; but it is hardly obtainable in this country, at least at a cost that would prove remunerative, and consequently either barley or oatmeal is usually employed. The latter, having a much higher percentage of fatty matter, is by far the more valuable. Great care should be taken that the meal used for fattening fowls has been freshly ground, and is free from any pungent or acrid flavour. It should be mixed with milk in place of water. If skimmed milk is used, the fatty matter which has been removed in the cream may be replaced advantageously by boiling up with the milk some hard mutton fat, such as the trimmings of the loins.

#### TURKEYS.

Turkeys, though exceedingly profitable, are not reared to as great an extent in this country as in France. The best breed to employ is the Cambridge crossed with the recently imported American, the crossing giving increased size and stamina. The hens when laying are very apt to conceal their nests, in which case they may be allowed to hatch their own eggs, or the latter may be removed and placed under large fowls. The eggs should be tested like those of fowls, on the eighth or tenth day, and only the fertile ones replaced in the nest. The chickens make



their appearance on the twenty-eighth day. The young are rather delicate, and should not be interfered with until the following day, as they require no feeding for the first twenty-four or thirty hours. During this time, as is the case with fowls, the young bird is digesting the yolk which is drawn into the body at the period of hatching and furnishes the first food.

Great care should be taken to place young turkeys at first in a dry situation, such as the foot of a wall facing the south, or under an open shed. The first food of the young turkeys should be egg and milk, prepared as for fowls; but it should be remembered that turkeys are much more addicted to feeding on green vegetables than fowls are. If allowed to wander at will, it will be noticed that they eat bitter herbs, such as dandelion and milky lettuces, and care little for whole corn. If ants' eggs can be obtained, such as are used by the gamekeepers for rearing pheasants, they will be found a most valuable addition to the food of young turkeys. But great dependence must be placed in the first instance on egg and milk, fresh meal and milk, lettuces run to seed, chopped dandelion, and such insect food as the birds can obtain for themselves. In wet weather, when the rain necessitates keeping them under cover, they should never be kept on hard ground, but the floor should be covered with dry soil or ashes. If the hens are cooped, the coops should be moved every day, the grass around them for some considerable distance being mown, as is done in the case of pheasant rearing.

Turkeys are particularly subject to cold in the head, causing swollen faces and sore eyes, which rapidly develops into roup, a most infectious and troublesome disease. Care must be taken therefore not to allow hens to wander with the young birds early in the morning, before the sun has dried the grass. Although delicate when young, turkeys are particularly hardy when old, and may be allowed to roost in the trees, where they do much better than in houses. For the market it is not necessary to shut them up, but they may be fed on soft food mixed with skimmed milk two or three times a day. In France, flocks of young turkeys are frequently put under the care of a girl, who drives them with a long light pole on to the stubbles, where they feed on the corn which would otherwise be wasted. This method of utilising the waste corn which is always knocked out in harvesting is very much neglected in England, although some farmers, by having movable poultry-houses on wheels, endeavour to carry it out. The rearing of turkeys is hardly to be recommended in damp localities, more especially where the soil is heavy and clayey; but in suitable situations,

where sufficient amount of attention can be given to the birds during the first few weeks of their lives, there is no form of poultry that pays better, as they always, about Christmas time or often before, realise very high prices in the markets, and can usually be sold privately, when the profit does not go into the hands of the middleman.

#### DUCKS.

The usual mode in which ducks are kept in a farmyard is the reverse of advantageous. The plan followed should be that adopted in the neighbourhood of Aylesbury and in the surrounding villages, where many tons of ducklings are reared annually and sent to the London markets, realising a most remunerative price. It is said that nearly 40,000*l.* per annum is paid to the neighbourhood for early ducklings. The breed chosen there is the white Aylesbury. The ducks are allowed on the water during the daytime, but kept under cover at night. To feed them well, the best plan is to put the food, which is generally oats, into a pan of water. If highly fed, they will lay as early as December, and the eggs are particularly valuable for producing early ducklings. They are hatched under hens on nests made in the usual manner on the ground with soft, short straw, which is much better than hay. The nest should not be allowed to become dry. If it does, the eggs may be sprinkled with lukewarm water daily. No interference with the newly hatched brood should take place until the following day. At Aylesbury the ducklings which are reared for the market are not allowed to go into water. After a few days three or four broods are given to one hen, and they are kept in small compartments in the rooms of the cottages of the rearers, or in sheds, each lot being separated by boards. The compartments are littered down with short straw, and kept particularly clean.

Unlike fowls, the young ducks require a very considerable proportion of animal food. Their first food should be hard-boiled eggs, mixed with boiled rice, and bullock's liver cut up into small pieces. This is given to them several times a day. After about a fortnight they are furnished with meal which is mixed with scalded chandler's greaves, and they also have a due supply of oats placed in water. Fed in this manner they rapidly attain a very considerable size, and at the age of ten or twelve weeks are fat enough for market. These early ducklings command a very high price. In the first of the London season nine or ten shillings a couple, or even more, is frequently given for them. At the age of about twelve weeks they begin to moult, and then the nourishment that they receive goes to the formation of new feathers, and they do

not increase in weight for another eight or ten weeks. Hence, there is no advantage in allowing them to remain over twelve weeks before killing them. The secret of success is to feed the young ones as rapidly as possible and get them into the market at the earliest possible period. Those ducks that are intended for stock, and not for killing, may be allowed to go into the water after some three or four weeks, but permitting them to swim when growing does not tend to increase their size.

The Aylesbury are by far the most profitable breed for market purposes; they are good layers and heavy birds. The Pekin breed, which has been introduced from China within the last few years, does not weigh as much as the Aylesbury, nor is it as advantageous for market. The ordinary coloured breeds of ducks are not so desirable, as the dark colour of the down, which is difficult to remove entirely, before sending to market, renders them less attractive in appearance when killed. In purchasing Aylesbury ducks for stock, the greatest care should be taken not to procure over-fatted specimens in which the belly trails on the ground. These are never fertile, both drakes and ducks being absolutely useless.

#### GEESE.

Geese will be found to be advantageous only under certain conditions. Where there is an opportunity of their grazing without expense, in the short grass of commons, they can always be kept to advantage. The large size exhibition geese are not to be recommended for farm purposes, as they are by no means good layers, and frequently are absolutely sterile. For the market the ordinary saddle-backed grey and white geese, if selected of good size and quality, are as good as can be employed. Geese as well as ducks should have a house to themselves, removed from the ordinary poultry. An unused pig-sty makes an excellent goose-pen. The nest should be made in the corner with mould covered with straw, and large enough for the goose to sit comfortably without risk of crushing the eggs. The young are hatched after thirty days, and may be fed at first with meal and milk. A little custard is also advantageous, and so are chopped lettuces and fine grass. The young at first need not be allowed to go to the water, as a large milk pan, half full of pebbles and water, is all that they require. After about a week no further care is necessary for them except giving them food. The most advantageous way to do this is to put the grain in a trough of water.

In the previous remarks I have not alluded to the employment of incubators, which are now used to a very considerable extent by those who hatch large numbers of fowls. Whether incubators can be employed advantageously by the small farmer, depends altogether upon the number of chickens that he contemplates rearing. I do not think an incubator of less size than one containing fifty eggs is at all desirable, as the external surface in proportion to the bulk renders it less easy to keep up a regular temperature, and a small number of eggs can be as easily hatched under hens. The most successful incubator is that manufactured by Hearson, in which the supply of heat is instantly shut off when it exceeds or even reaches the desired temperature, which can be regulated to any required degree. I have tested this incubator for some years, and find that it hatches as large a proportion of eggs as the best hens. The eggs are placed in circumstances in which the natural conditions of hatching are most carefully reproduced. Moisture rises from below, the heat is given above, and the natural temperature cannot possibly be exceeded, however great the excess of heat from the lamp or gas employed in the machine. Incubators in which the heat depends on the supply of hot water once or twice a day are always altering their temperature, and are consequently unsuccessful. Others, in which the eggs are exposed to the fumes of hot air rising from the combustion of a lamp, are even less to be relied upon, as the eggs do not hatch well, unless the air in which they are contained is particularly pure.

The impurity of the air is one of the chief causes why the eggs in an overcrowded or dirty fowl-house never hatch as well as those that are sat upon by the hens out in the open air, as under a hedge, or any other concealed situation. An incubator, therefore, should never be placed in a close-confined room, but in some compartment or shed where the atmosphere is particularly pure. The chicken breathes through the pores of the shell for many days before it escapes from the egg, and is particularly susceptible to the foul effects of an impure atmosphere in the early stages of existence.

Whether or not an incubator can be used depends entirely on the requirements of the farmer, but should it be determined to employ one, it is most desirable that an efficient instrument should be selected, as the use of cheaply constructed machines will only end in disappointment.

W. B. TEGETMEIER.

---

## THE TUBERCLE BACILLUS.

A VALUABLE and instructive article was contributed to Part II. of the Journal, last year by Mr. Duguid, on "Tuberculosis in Animals, and its relation to Consumption in Man," in which the author pointed out that this subject was of just as much interest and importance to stock-owners and others connected with the cattle trade as to Sanitary Medical officers and guardians of the public health.

Mr. Duguid fully justified this statement in a very temperate discussion of the possible transmission of tuberculosis from the cow to man by the flesh and milk of animals suffering from this disease, and especially in his concluding remarks on the need for legislation in Great Britain in connection with this subject, and on the vexed questions of slaughter and compensation.

No scientific subject of late has received so much attention in the columns of the daily and agricultural press as tuberculosis, and indeed the tubercle bacillus has been a topic of daily conversation. There is a desire for information on the part of intelligent laymen, while in scientific professional circles the interest attaching to tuberculosis is steadily increasing, and the importance of a thorough investigation of the subject in all its aspects is daily becoming more fully recognised. It is proposed, in this paper, to give some account of the tubercle bacillus and its products, and of the effect of Koch's liquid on tubercular animals, avoiding as much as possible all technical expressions, which would render the account unintelligible to many.

### THE DISCOVERY OF THE TUBERCLE BACILLUS.

It had long been known that consumption or tuberculosis was communicable from one animal to another by experimental inoculation, but investigators failed to find out the cause or contagium. In 1882, Koch discovered the *Bacillus tuberculosis*, and published the evidence upon which he based his conclusion that this microbe was the germ of the disease.

This minute parasite is a vegetable organism. It is found in all forms of tuberculosis in man and the lower animals. It is readily detected in the sputum or expectoration of human patients suffering from phthisis or tuberculosis of the lungs. The discovery of this micro-organism was therefore of the greatest possible value, for its presence is a certain indication of the existence of tubercular disease (see Plate I.).

## DESCRIPTION OF PLATE I.

*The Tubercle Bacillus in Man and Lower Animals.*

The figures in this plate represent the bacilli in tuberculosis of different animals, examined under the same conditions of amplification and illumination.  $\times 1200$ .

Fig. 1.—Bacilli in pus from the wall of a human tubercular cavity. In this specimen the bacilli are shorter than those in tubercular sputum, and are very markedly beaded.

Fig. 2.—Bacilli in pus from a tubercular cavity from another case in man. They are present in the preparation in enormous numbers. The protoplasm occupies almost the whole of the sheath, and the bacilli are strikingly thin and long.

Fig. 3.—Bacilli in sputum from an advanced case of phthisis, showing the ordinary appearance of bacilli in sputum—sometimes beaded, sometimes stained in their continuity—occurring both singly and in pairs, and in groups resembling Chinese letters.

Fig. 4.—Bacilli in a section from the lung in a case of tuberculosis in man. The bacilli in human tuberculosis are found in, and between, the tissue cells, and sometimes, as in equine and bovine tuberculosis, in the interior of giant cells, but not so commonly.

Fig. 5.—From a cover-glass preparation of the deposit in a sample of milk from a tubercular cow. The bacilli were longer than the average length of bacilli in bovine tissue sections, and many were markedly beaded.

Fig. 6.—From a section of the brain in a case of tubercular meningitis in a calf, showing a giant cell containing bacilli with the characters usually found in sections of bovine tuberculosis.

Fig. 7.—From a section of the liver of a pig, with tubercle bacilli at the margin of a caseous nodule.

Fig. 8.—From a cover-glass preparation of a crushed caseous mesenteric gland from a rabbit, infected by ingestion of milk from a cow with tuberculosis of the udder.

Fig. 9.—From a section of lung in a case of equine tuberculosis, showing a giant cell crowded with tubercle bacilli.

Fig. 10.—From a section of lung from a case of tuberculosis in the cat, with very numerous tubercle bacilli.

Fig. 11.—From a cover-glass preparation of a crushed caseous nodule from the liver of a fowl, with masses of bacilli. These are for the most part short, straight rods, but other forms, varying from long rods to mere granules, are also found.

Fig. 12.—From sections of the liver and of the lung in a case of tuberculosis of an ostrich (*Rhea*). Isolated bacilli are found, as well as bacilli packed in large cells, colonies of sinuous bacilli, and very long forms with terminal spore-like bodies and free oval grains.

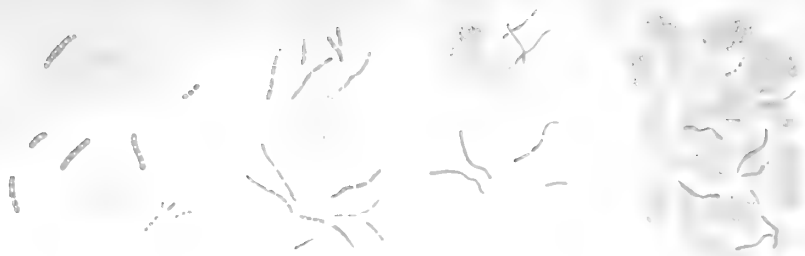

Fig 1 MAN.(Pus) Fig 2 MAN.(Pus) Fig 3.MAN.(Sputum) Fig 4. MAN.(Lung)



Fig.5. COW.(Milk) Fig.6. CALF.(Brain.) Fig.7. PIG.(Liver.) Fig.8. RABBIT (Gland.)

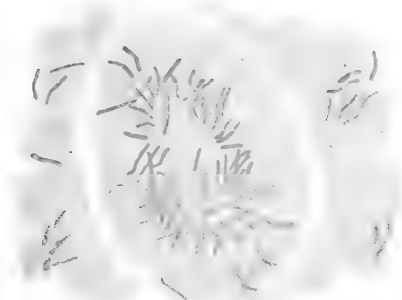

Fig. 9. HORSE. (Lung)



Fig.10. CAT. (Lung.)



Fig. 11. FOWL (Liver.)



Fig.12. OSTRICH. (Liver.)

THE TUBERCLE BACILLUS IN MAN AND THE LOWER ANIMALS





The mere discovery of a particular parasite in association with a disease is, however, no proof that it is the cause of the disease. To establish a causal relation a great deal of evidence is necessary, for it must be proved that the micro-organism *does produce* the disease in question. To obtain such evidence we must first isolate the bacillus from tubercular tissues; it must be grown artificially outside the animal body, and with a pure cultivation we must be able to produce the disease by introducing it into susceptible animals.

### THE CULTIVATION OF THE TUBERCLE BACILLUS.

Koch pointed out that, if a fragment of tissue containing the bacillus were inserted into solidified blood serum<sup>1</sup> a growth of the bacillus took place, which after a few weeks became easily visible to the naked eye. Minute dry scales developed on the surface of the cultivating medium. By sowing the bacillus in fresh tubes or flasks containing this medium, the cultivation of the bacillus could be kept up indefinitely. The cultivating medium, whatever its composition, must at the outset be free from all micro-organisms of every kind.

For most bacteria, beef-tea containing gelatine is used. A small quantity is allowed to set in a test-tube, the most convenient vessel for use in the laboratory. This medium readily liquefies if the temperature is raised; and if, therefore, it is necessary to grow the bacteria in an incubator, a meat-jelly is used in which Japanese isinglass (*agar-agar*) is substituted for the gelatine. After sowing the bacteria on the surface of this jelly, the test-tubes are placed in the incubator at the temperature of the blood.

For the cultivation of the tubercle bacillus Koch, as already mentioned, employed solidified sterilised blood serum, but the preparation of this medium took so much time and was so complicated that but few succeeded in verifying his discovery.

On the other hand, the preparation of meat-jelly is comparatively easy. A great advance was therefore made in the study of the life-history of the tubercle bacillus when the French bacteriologists, Nocard and Roux, discovered that the addition of 5 per cent. of glycerine to meat-jelly prepared with agar-agar afforded a soil on which the tubercle bacillus could be cultivated in abundance with the greatest facility.

---

<sup>1</sup> Blood is allowed to clot in clean glass vessels, and the liquid part, or serum, is decanted into test-tubes and solidified by heat.

Just as we can grow tropical plants in this country by supplying the necessary conditions of temperature, moisture, and soil in hothouses, so these microscopic plants or bacilli can be cultivated outside the animal body by supplying the necessary food and by keeping them in an incubator with careful regulation of the temperature.

It is not absolutely necessary to employ the cultivating media in a solid state, but it is preferable when we require to study the appearance as presented to the naked eye of the bacilli *en masse*. Beef-tea with glycerine, but without either gelatine or agar-agar, can be employed, and when the growth has developed to its full extent, the bacilli can be separated by filtration through porcelain, and the filtrate examined. The secretion of the bacillus, if such has been formed, is thus separated, and the changes which have taken place in the liquid by the digestion of the complex substances in the broth can be ascertained.

#### TUBERCLE BACILLI AND THE WHITE BLOOD CORPUSCLES.

Having obtained cultivations on either solid or liquid media, the next step is to inoculate susceptible animals. Koch assured us that the inoculation with the isolated bacillus of such animals as rabbits, guinea-pigs, and monkeys, produced the disease tuberculosis, and hence the tubercle bacillus is very generally accepted as the active agent in the production of this disease.

The hereditary character of consumption, however, indicates that we have to deal with something more than the life-history of the tubercle bacillus. If the disease be solely due to the inhalation of a micro-parasite, why should the disease be hereditary, and why should tuberculosis in cattle be increased by breeding in and in? We have obviously not only to deal with the parasite, but with other factors. Susceptibility to the disease can be increased by unhealthy surroundings and inherited.

According to the theory of Metschnikoff, a Russian bacteriologist, there is a constant warfare between the white blood cells<sup>1</sup> and bacteria. If an animal has immunity from or is proof against a disease, and also in cases of recovery from an attack of a disease, the white blood cells or "phagocytes" attack and

---

<sup>1</sup> The blood consists of a clear fluid called *liquor sanguinis*, with little disc-shaped bodies called red corpuscles, and colourless protoplasmic cells called white corpuscles. The latter constantly change their form by sending out and retracting delicate processes like the small unicellular organisms known as amœbæ. They migrate when a tissue is in need of repair, passing through the delicate wall of the minutest blood vessels.



a

b

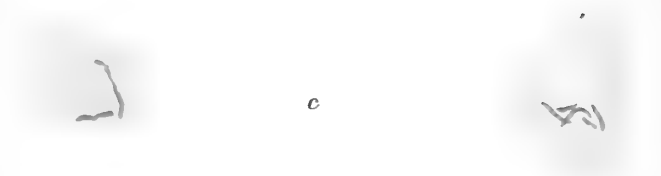

c



d

e

TUBERCLE BACILLI AND PHAGOCYTES OF THE FROG.

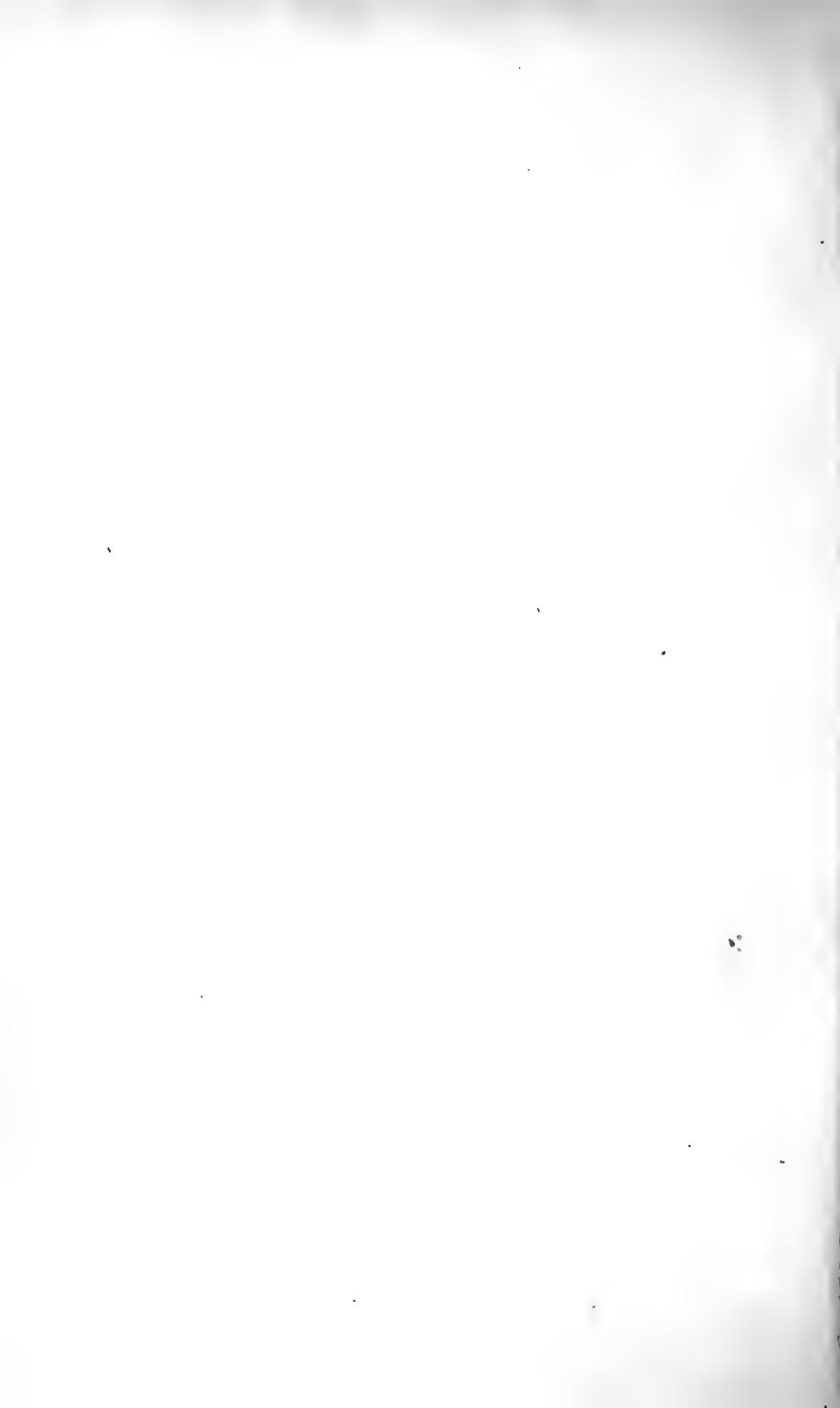

destroy the invading micro-organisms. If, on the other hand, there is no immunity, the phagocytes are unable to cope with the bacteria. The latter destroy the white blood cells, increase and multiply, and ultimately destroy their host.

These phenomena have been studied by the writer after injecting a few drops of a cultivation of the tubercle bacillus in broth into the dorsal lymph sacs of frogs, and withdrawing some of the lymph by means of a capillary pipette at intervals of a few hours and then of weeks. The lymph cells, white blood cells, or phagocytes, can be seen to take up one or more tubercle bacilli, just as an amœba takes up foreign particles. In some cases the cells are completely filled with the bacilli (see Plate II.<sup>1</sup>).

The question arises whether the cells actually take up and destroy living tubercle bacilli, or whether the bacilli are first destroyed by the blood or lymph which, in animals having an immunity, is unsuitable for the growth of the bacilli, or is even capable of destroying them. Whichever may be the right explanation, the practical lesson is that the tissues and blood must be kept in a state of health by proper hygienic surroundings, and by absolutely rejecting tubercular subjects for breeding purposes when dealing with animals, and by discouraging marriage of tubercular persons when dealing with mankind.

#### DESCRIPTION OF CULTIVATIONS OF THE BACILLUS.

Having explained the method of cultivating bacteria, it may be of interest to more fully describe the appearances of the cultivations of the tubercle bacillus. During the past year, the writer has confirmed and extended the observations of Nocard and Roux, and photographs of cultures of the bacillus are given in the accompanying woodcuts (Figs. 1-7). The bacillus was isolated from the expectoration of a phthisical patient, and successive sub-cultures have been prepared up to the tenth generation. In these photographs the part of the test tube is represented in which the meat jelly has been allowed to set with a sloping surface; on this sloping surface the bacilli were sown by means of a platinum needle, the point of which was charged with the bacilli. The platinum inoculating needle consists of two

---

#### <sup>1</sup> DESCRIPTION OF PLATE II.

##### *Tubercle Bacilli and "Phagocytes" of the Frog.*

(a) White blood cells of the frog; (b) cells enclosing single bacilli; (c) cells enclosing two or more bacilli; (d) and (e) cells packed with more or less disintegrated bacilli,

FIG. 1.

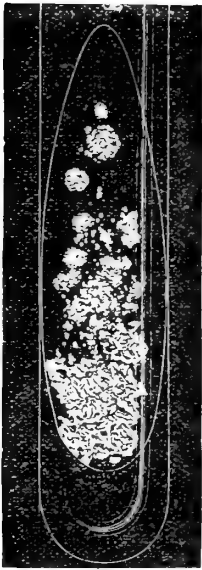

FIG. 2.

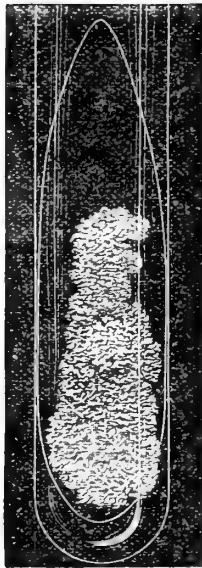
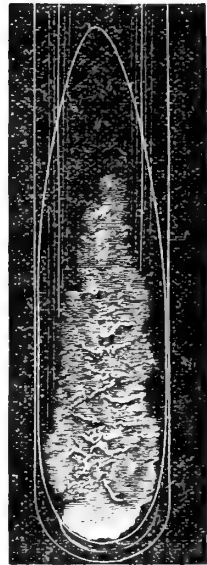

FIG. 3.



Fourth sub-cultures on glycerine agar-agar, nearly ten months old, from human tubercular sputum. Inoculated April 17, 1890. (From photographs.)

Another sub-culture on glycerine agar-agar of the same age and source as Figs. 1 and 2.

FIG. 4.

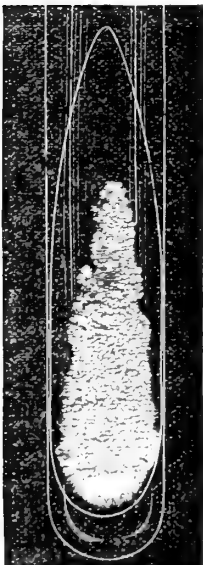

FIG. 5.

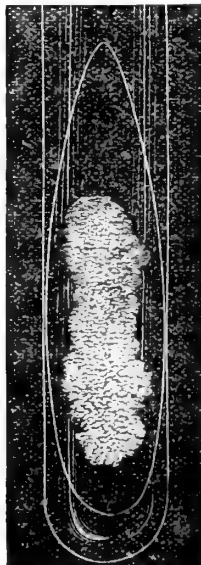
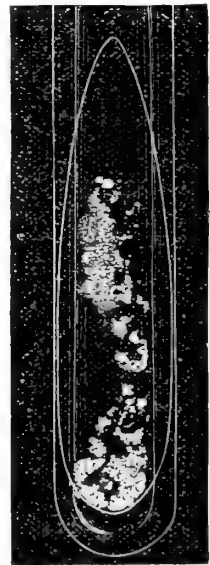

FIG. 6.



Fifth sub-culture on glycerine agar-agar more than six months old. Inoculated July 22, 1890.

Sixth sub-culture, from the same source, more than three months old. Inoculated October 15, 1890. (From photographs.)

Eighth sub-culture nearly two months old. Inoculated December 8, 1890. (From photographs.)

inches of platinum wire fused into the end of a glass rod about the length of a penholder. This needle can be sterilised by holding it in the gas-flame, and when cool the point is dipped in the bacilli to be inoculated, and then lightly traced over the surface of the jelly.

The individual bacilli increase, forming 'colonies,' which have the appearance of minute white points. These go on increasing in size, and are sometimes smooth and moist, at other times dry and crinkled. According to the number of the bacilli inoculated, the colonies will either remain isolated or join and form a more or less continuous coating.

The appearances are much more characteristic when this medium is, comparatively speaking, dry. A semi-transparent membranous growth develops and thickens, and sometimes assumes a characteristic lichenous appearance. In about six weeks to two months the culture has fully developed.

In old cultures, especially when the individual colonies remain isolated, the appearance is very characteristic. The consistency of the growth depends upon the character of the soil and the age of the culture. If the medium is moist the growth is moist and viscous, but more often it is distinctly tallowy, and in old and dry cultures scaly and friable.

In glycerine-broth, without either gelatine or agar-agar, luxuriant growths can be obtained in a few weeks. In four or five days minute flakes or specks are visible, which steadily increase in size, and, subsiding to the bottom of the flask, form ultimately a very copious deposit. This deposit is extremely tenacious, and on shaking the flask it rises in stringy masses, giving an appearance which is quite characteristic. If the flask is left undisturbed, a delicate film forms over the surface of the liquid, which can be readily broken up by gentle agitation. If undisturbed for several weeks this film increases in thickness, is irregularly fissured, and has more the appearance of tallow floating on the surface.

To be certain that the growth we have obtained is in reality a growth of the tubercle bacillus, we must examine it by the method we employ for the detection and examination of the bacilli in tubercular tissues,

FIG. 7.

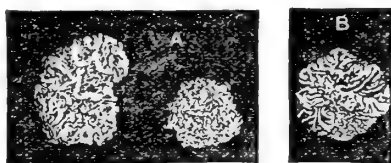

A, Isolated colonies on glycerine agar-agar after nearly ten months' growth. Sub-culture from human sputum (fourth sub-culture). B, Isolated colony after seven months' growth. (From photographs.)

## MICROSCOPICAL EXAMINATION OF THE BACILLI.

The bacilli are colourless, and therefore not easily distinguished from the tissues in which they grow; we have, therefore, to employ the process of staining them with an aniline dye. By this means we can readily differentiate the bacilli, and study their form and their relation to the tissues in which they grow. It is this method which gives us an invaluable means of ascertaining the existence of tuberculosis.

To illustrate this, let us suppose that we have to deal with an indurated condition of the udder of a cow. To distinguish between chronic inflammation and tubercular disease may be a matter of the greatest difficulty, and perhaps of impossibility, if we trust to symptoms and physical signs. And yet it is a matter of the greatest importance, for the danger of employing the milk of cows suffering from udder tuberculosis is, especially to children, a matter beyond doubt.

But if some of the milk is drawn off into a test-tube and set aside for an hour, we can readily examine the sediment for tubercle bacilli. The supernatant liquid is poured off, and a little of the sediment spread out upon a cover-glass. This is allowed to dry and is fixed by passing the cover-glass through the flame of a gas-burner or a spirit-lamp. The cover-glass is then floated, with the prepared side downwards, on hot carbolised fuchsin<sup>1</sup> in a watch-glass for three to five minutes. The cover-glass is next transferred to dilute sulphuric acid, which washes the stain out of everything except the bacilli. If desired, a contrast stain can be given to the rest of the preparation by placing the cover-glass for a couple of minutes in methylene blue. In such preparations the tubercle bacillus is stained brilliantly red, and the tissue cells and any other micro-organisms are stained blue.

In dealing with the diseases of animals, this power of retaining the stain in the presence of acid is an absolute indication of the presence of the tubercle bacillus. In man this statement does not hold good, for the same occurs in the case of the closely allied leprosy bacillus.

If now the cultivations of the bacillus are examined by the same method, we can readily detect the same bacilli; but they are found to be shorter and thicker than in human sputum, and for the most part without the beaded appearance. In old

---

<sup>1</sup> A crimson aniline dye prepared by dissolving 5 parts of crystals of fuchsin in 10 parts of alcohol and 100 parts of a 5 per cent. watery solution of carbolic acid.

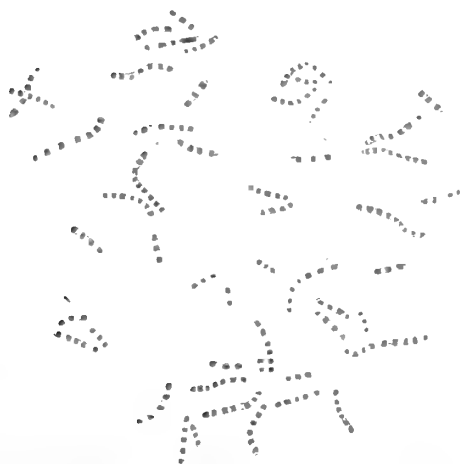

FIG. 1.



Cover-glass preparation, stained with carbolic fuchsin and treated with sulphuric acid, from a cultivation on glycerine agar-agar.  $\times 1200$ . (Powell and Lealand  $1/12$  apochrom., o.i. E.P. 10. Lamplight illum., edge of flame.)

FIG. 2.



Cover-glass preparation of a cultivation in glycerine milk stained by Neelsen's method (carbolic fuchsin and sulphuric acid.)  $\times 1200$ .

## PURE CULTIVATIONS OF THE TUBERCLE BACILLUS.



cultures on glycerine-agar-agar the number of granular or beaded bacilli increases, and there are also numbers of peculiar forms. These are long bacilli, in some cases two or three times the length of an ordinary bacillus, provided with a club-shaped enlargement, and in other cases bacilli with short lateral branches (see Plate III., fig. 1). The bacilli with swollen extremities and the branched forms were first observed by Nocard and Roux. In milk the appearance is very striking, many bacilli attaining in old cultures a great length, and all are more uniformly beaded than in any other cultivations (see Plate III., fig. 2). In old cultivations we can observe the formation of spores or seeds both in stained and unstained preparations. In the latter case they are recognised in the form of one or two highly refractive bodies in the individual bacilli.

#### CHEMICAL PRODUCTS OF THE BACILLUS.

To understand the formation and effects of the chemical products of the tubercle bacillus, it is necessary to briefly refer to a most important branch of pathological chemistry. So long ago as 1822, Gaspard and Stick discovered an intensely poisonous substance in extracts of the dead subject. In 1836, Panum found a poison in putrid material; later, a crystallisable poison, *sepsin*, was obtained from putrid beer, and a venomous nitrogenous body from putrid meat. This subject did not attract very much attention until the classical researches of Selmi. Selmi, in a celebrated poisoning case, demonstrated the presence of an alkaloid as the result of post-mortem change; up to this time the discovery of an alkaloid in the body after death was considered as a proof of a poison having been administered during life. This stimulated the investigation of these newly discovered poisons, and the researches of Gautier and Selmi established the fact that albuminoid substances undergoing decomposition<sup>1</sup> give rise to the formation of animal alkaloids. These animal alkaloids Selmi named ptomaines, from *ptoma*, a dead body. Brieger, finding that the products of putrefaction were less poisonous than the products of pathogenic bacteria, suggested the name *toxines* to distinguish the latter.

Ptomaines, or animal alkaloids, have been divided into two classes: those which are non-oxygenous, liquid, and volatile; and those which are oxygenous, solid, and crystallisable.

---

<sup>1</sup> Decomposition, or putrefaction, is the result of the growth of septic bacteria.

As examples of the non-oxygenous ptomaines, there are the following:—

*Parvoline*, an oily liquid of an amber colour, obtained from putrid mackerel and horseflesh.

*Hydro-collidine*, prepared from the same sources. This substance is so highly poisonous that it was compared by Gautier to the venom of the cobra.

*Collidine*. Another highly poisonous substance, obtained from putrid gelatine and pancreas of a bullock.

*Neuridine*, prepared from fish, flesh, and decaying cheese.

*Cadaverine*, obtained from ordinary putrefaction, from herring brine, and from pure cultivations of the common bacilli found by Koch in Asiatic cholera, and by Finkler in cholera nostras.

*Putrescine*, from putrefaction. This substance and the two former are alike poisonous, and produce some of the symptoms of cholera.

Of oxygenous ptomaines, which in some cases are found also in healthy tissues, the following may be mentioned:—

*Neurine*, from putrefaction after death.

*Choline*, from bile.

*Muscarine*, from a poisonous mushroom (*Agaricus muscarius*), and from putrid fish. All these are highly poisonous.

*Gadinine*, from putrefying codfish.

*Mytilo-toxine*, the active agent in cases of mussel-poisoning.

*Typhotoxine*. A poison isolated from pure cultivations of the bacillus of typhoid fever.

*Tetanine*, from cultivations of the bacillus of tetanus.

Meat poisoning, produced by the consumption of putrid sausages, hams, and poultry, is attributable to the presence of poisonous animal alkaloids.

But the poisonous substances of most interest to the bacteriologist are those isolated from pure cultivations of the pathogenic or disease-producing bacteria, including alkaloids and albumoses or tox-albumins, such as *cadaverine* and *putrescine* from cultivations of Koch's common bacillus; *typhotoxine*; *tetanine*; an albumose and alkaloid from the anthrax bacillus; and *tuberculin* from the tubercle bacillus.

#### TUBERCULINE.

At the International Medical Congress at Berlin, August 1890, Koch announced that he had discovered a substance which prevented the growth of tubercle bacilli, not only in tube cultivations, but in the bodies of animals. On November 14 a further publication was made, describing the effects upon lupus, con-

sümption, and other forms of tubercular disease. On January 14, 1891, Koch announced that the substance employed in his anti-tubercular treatment was a glycerine extract of pure cultivations of the tubercle bacillus. This extract now bears the name of *tuberculine*.

Koch, after pointing out that the effective substance in this extract could be precipitated by absolute alcohol, stated that "for application in practice, this purification of the glycerine extract offers no advantage." This would indicate that Koch regarded the isolation of the active material in a pure state as superfluous. It seemed to the writer, who had been simultaneously investigating the products of the tubercle bacillus, a matter of great scientific interest to determine, if possible, the chemical properties and physiological effects of the separated products. In a conjoint investigation with Mr. Herroun, the products of the tubercle bacillus in pure cultivations in glycerine-broth have been shown to contain *albumose* and an animal alkaloid, or *ptomaine*.

It is much to be regretted that the details of experiments with tuberculine on animals have not been published by Koch, and that details are wanting of the chemical properties of the substance or substances contained in his extract. The hope that the extract would prove a curative agent has almost overwhelmed the scientific side of the subject, and the information which is most likely to be of real value is probably that which has hitherto been withheld from publication.

#### EFFECT OF TUBERCULINE ON HEALTHY AND TUBERCULAR ANIMALS.

With the assistance of Dr. Abraham, who was one of the first to receive Dr. Koch's liquid from Berlin, the writer injected guinea-pigs with centigramme doses. Two tubercular guinea-pigs and one healthy one have been treated since January 7. Two other guinea-pigs in the same stage of tuberculosis were killed and carefully examined, both macroscopically and microscopically, as a guide to the condition of the internal organs in the cases selected for treatment. The first injection in the tubercular guinea-pigs caused rise of temperature, swelling of the diseased glands, and redness of the surrounding skin. The second and subsequent injections produced a rise of temperature and tenderness, but no sudden glandular swelling. In one guinea-pig, which had been inoculated with bovine tuberculosis, the tubercular glands steadily increased in size. The temperature reaction was most marked after the fourth injection, when

it reached  $107\frac{2}{5}^{\circ}$  Fahr. in two hours. After nine injections death resulted, and at the post-mortem examination the spleen, liver, and lungs were found to be diseased, the spleen and liver being almost solid masses of tubercular deposit. In the other guinea-pig, inoculated with human tuberculosis, the disease is progressing, but the animal is, at the time of writing, still living. With the exception of a very slight rise in temperature, the healthy guinea-pig was not affected by the injection. In France Jaccoud inoculated a guinea-pig with Koch's liquid, and subsequently inoculated tubercular virus; and the result led him to conclude that previous impregnation of the system with Koch's liquid had in this case no preventive action. Dujardin-Beaumez made similar experiments with similar results. Animals were inoculated with Koch's tuberculine and then with the virus of tubercle; in other cases he inoculated with tubercle first and afterwards with tuberculine. In both series the animals died of tuberculosis.

#### EFFECT OF TUBERCULINE ON CATTLE.

In the Veterinary Institute at Dorpat, Gutmann injected three tubercular cows with tuberculine. In all three animals the temperature began to rise about eleven hours afterwards, and in all during the "reaction" there was some difficulty of breathing and loss of appetite. The disease was diagnosed partly by the physical examination, and partly by the detection of bacilli in the bronchial mucus and in the milk, and by changes in the lymphatic glands. Gutmann concluded that Koch's liquid was an aid to diagnosis. At the Royal Veterinary College the writer injected a cow, supposed to be tubercular, on two occasions with doses of two and three centigrammes. The temperature, taken hourly, remained normal, but increased cough was noted. A third dose of fifty centigrammes was followed by a negative result, and a fourth dose of one gramme of the liquid produced a slight rise in temperature. The case is still under observation.

In a subsequent article the writer hopes to say more on the question of cure, and the effect on animals in relation to diagnosis.

EDGAR M. CROOKSHANK.

---

## TECHNICAL EDUCATION IN AGRICULTURE.<sup>1</sup>

It is not easy to frame a concise definition of what is meant by agricultural education, though it may be regarded as embracing a knowledge of the soil, of the plant, and of the animal. An adequate knowledge under these three heads must necessarily involve considerable time in its acquirement, and it offers a wide field of study and investigation for anyone who would wish to be, in the true sense of the term, a thorough agriculturist. Thanks to the progress of science during these later years, the means whereby it is possible to acquire a knowledge of the soil, of the plant, and of the animal have been much increased; consequently there is less excuse to-day than there was thirty or forty years ago for ignorance respecting what may be regarded as common agricultural knowledge.

Notwithstanding this, the fact remains that a knowledge of the soil, of the plant, and of the animal will not, by itself, make a man an agriculturist. He must acquire this knowledge on the one hand, but, on the other hand, he has to familiarise himself with the means and the methods by which the farmer is brought into relationship with the soil, with the plant, and with the animal—in a word, with that which is embodied in the comprehensive term “practice.”

There is still another side of the farmer's life, which, for want of a better phrase, may be called the business side: not only has the farmer to possess a knowledge of the soil, the plant, and the animal, and to rightly appreciate his own relation thereto, but he has to face his fellow men in the markets of the world. If he cannot successfully deal upon the markets, then his scientific education is practically of little use or value to him, for it is in the markets that the farmer must look for his final school of examination. No amount of scientific education, however thorough and comprehensive it may be, can be regarded as of practical agricultural value unless it is so made use of by the recipient that he can at the proper time focus, as it were, his energies on a given subject, and turn to the best advantage that which may come before him when he is brought face to face with the men from whom he has to buy and the men to whom he has to sell. A competent critic has dissented from

---

<sup>1</sup> Based upon an address delivered before the Newcastle Farmers' Club, January 3, 1891.

this view because, as he says, it reduces the farmer to the level of a huckster. Admitting, however, that scientific knowledge properly applied will enable a farmer to produce better crops and to breed better animals, without increasing their cost, it is none the less a fact that unless the commercial capacity—the trading instinct—be well developed in him, his bargains are not unlikely to prove unprofitable.

#### AGRICULTURE NOT A SCIENCE.

Whilst, therefore, it is by no means implied that a scientific and technical training will not greatly help a man in producing that which he has to sell, and in valuing that which he wishes to buy, it is desirable to emphasise the fact that agriculture is not a science. Much misunderstanding has, indeed, arisen through regarding agriculture as a science. We might as well talk of the science of plumbing, or of building, or of seamanship, as of the science of agriculture. Agriculture is an art, an industry, and, above all, it is a business in which commercial principles will come to the front as much as in any other of the many industries to which human ingenuity is applied.

#### TECHNICAL EDUCATION.

With regard to technical education in agriculture, it may be useful to point out that technical education (*τέχνη*, an art or industry) consists by no means exclusively of scientific education. There are many sciences which bear upon the art of agriculture, and which help us to understand its principles; but technical education in agriculture involves something more than instruction in the sciences which shed light upon it. These may be broadly grouped as mathematics and mechanics, physics and chemistry, and the natural history sciences, and, in so far as they bear upon agriculture, are of direct agricultural value. But, although they are useful as throwing light upon the art, or industry, or business of agriculture, they only form a part of that technical knowledge which every agriculturist should possess. In addition to these subjects, there are others, of a less purely scientific nature, which should undoubtedly be included in any complete scheme of technical instruction in agriculture. As an example may be mentioned surveying, which is to a great extent an art based upon mathematical principles.

Book-keeping, again, may be regarded as the key to the farmer's position, and it is not easy to suggest any subject capable of more direct and profitable application than this. A



farmer who can properly apportion to the various sections of his business the shares of receipts and expenditure which belong to them, has gone a long way towards solving the difficulties of his profession. Hitherto book-keeping has occupied a somewhat subsidiary position. This should not continue, for it supplies the method by which, from month to month and from year to year, a farmer can gauge his position and feel his way. A valuable result of a sound system of book-keeping is that it suggests to a farmer the discontinuance of that part of his business which is carried on at a loss, and the directing of his energies more especially to that which is proved to be profitable. It deserves to be noted that the Royal Agricultural Society long ago recognised the value of book-keeping, as a branch of agricultural education, by introducing it as an obligatory subject into the syllabus of its Senior Examination.

We might also include what may be termed commercial knowledge. There seems to be a great lack—if we take England through—of a proper comprehension of the relation of markets one to another. Commercial knowledge would, to a considerable extent, promote the comparison of the markets of different districts. With the enormous facilities for transport now existing, the influence of one market upon another is determined not so much by its geographical position as by the means or the rapidity by which produce can be transferred from one place to another. The railway, the steamship, and the telegraph help to annihilate distances. In the towns of England we consume bread made of flour grown upon the western prairies of North America, and in some of our butchers' shops we find mutton raised upon the sheep runs of New Zealand.

Another branch of technical instruction in agriculture, and one which deserves to be made more prominent than ever it has been, is that relating to statistics. It is of so much importance, that there need be no hesitation in putting it in the front rank. The reason for this has been foreshadowed in what has just been said about the markets of the world and their virtual proximity to each other, owing to the excellent facilities for transport which exist. Any farmer—particularly if he be a grazier—who will take the trouble to study the agricultural statistics of this country, will be enabled, to a certain extent, to forecast his position, and to see what would probably be the best line for him to take in the ensuing season. This assertion is not made upon a mere theoretical basis, for the plan has been put into practice by more than one shrewd farmer, who, year after year, profits by a careful study and analysis of the Agricultural

Returns of Great Britain. The Returns for the year 1890 have come out—for the first time—under the direction of Major Craigie, who is singularly apt in the art of presenting statistics. A decided improvement, especially in the matter of comparison, is noticeable in the current Returns. We learn for the first time the sources of certain agricultural products which are placed upon our markets to compete with the home products. In the course of the tables there may be observed quite a dozen distinctive details which have never hitherto been apparent in the Returns. It is submitted that statistics should enter into an agriculturist's course of study as a part of his technical education. It can hardly be called a pure science, but it is a branch of knowledge in which scientific principles are largely involved—especially in the little understood process of the determination of averages—and which bears an essential relationship to the commercial condition of the country.

#### FIELD EXPERIMENTS.

Another subject connected with technical instruction is that relating to field experiments. Field experiment, in the strict sense of the term, is the most hazardous kind of inquiry that any scientific investigator can enter upon. It is surrounded by so many difficulties and so many chances, and the errors of experiment—to use a phrase well known to scientists—are so great, that it requires a mind of the first capacity to eliminate these incidental errors and arrive at the truth. Fortunately we have, in England, the finest type of experimental farm in the world—that at Rothamsted. But that farm has been carried on under such exceedingly careful conditions that, if anyone will take the trouble to study the results established there, and in particular note the extreme exactitude which has characterised the work throughout, he will become conscious of how immensely difficult it would be to parallel these experiments elsewhere.

The successful prosecution of such investigations demands considerable experience. How, then, can we rely upon the judgment of a young agriculturist—a beginner? The student is hardly the person to ask for an opinion on an experimental point, or for the interpretation of experimental evidence. As well might we make a law student a judge in order to train him for a barrister. What we really want are men of trained habits of thought and of ripe experience. These are the men to whom such problems in original research more directly appeal. In no other industry, involving scientific principles, except that of agriculture, has it ever been suggested that the crude student should be educated

by assuming a critical mental attitude with respect to problems lying in the indefinite region between the known and the unknown.

As a matter of fact, most of the so-called agricultural experiments are directed not so much to the work of investigation as to that of demonstration. They serve as examples or illustrations, answering on a large scale the same purposes as experiments performed in a laboratory. Whilst, therefore, the prosecution of agricultural experiments, *i.e.*, of those directed to original investigation, should be kept distinct from this subject of technical instruction in agriculture, we may multiply, as much as we like, fields of demonstration, and repeat, under different conditions of climate, season, soil, and situation, the experiments carried out elsewhere.

#### THE SCIENCE AND ART DEPARTMENT.

The Science and Art Department, South Kensington, is a Government organisation which has exercised a very profound influence upon the present position of this country. It has now been in existence for upwards of thirty years, and it would be difficult to over-estimate the good it has done. It was not, however, until twelve or thirteen years ago that it first included Agriculture as a subject of instruction in which grants were made. Even then it did not recognise it as a business, because it is opposed to the rules and policy of the Department to recognise any business as such. But, just as the Department had previously recognised the "Principles of Mining"—that is to say, the scientific principles involved in or underlying the art or business of mining—so now it recognised the "Principles of Agriculture," and instituted examinations in the subject which have been continued yearly ever since. It has fallen to the writer's lot to take part in these examinations from the commencement, and he has—up to the present time—read and assigned marks to not less than 10,000 papers. There have been indubitable signs of progress from year to year. The papers written for what is called the elementary stage, by boys of twelve to sixteen years of age and upwards, are far superior now to those sent up ten years ago. The reason is that the teaching has improved. The answers of ten years ago were of a feeble character, and showed emphatically that the teachers themselves were inefficient. Now the answers are of an intelligent kind, and are often very well expressed, thereby showing that the lads are better taught. These students are mostly instructed in country schools, and chiefly in the evening. In fact,

in the Science and Art Department this country possesses an organisation which has done more than any other institution to foster and encourage the system of evening classes—a system which is being wisely followed in connection with the further extension of the study of agricultural subjects.

So long as the Science and Art Department retains the subject of the Principles of Agriculture, rural authorities will be well advised to avail themselves as much as possible of the privileges it offers. The value of the Department should not be underrated; it has a comprehensive organisation, and a large sum of money is annually at its disposal. Most of this money is paid to teachers on the results of the examination of their pupils. It is possible, in some rural districts, to group the science subjects of the Department in such a way as to provide a comprehensive curriculum. Machine construction and drawing, mechanics, physics, and steam—take these four subjects, and apply them to the principles of agriculture in the case of an intelligent boy who is going to spend his life upon the farm. A knowledge of this group of subjects would make him a very handy man amongst the machinery which is daily becoming more indispensable to the farm. Moreover, from studying such a group of allied subjects, a boy would acquire knowledge that would help him to become an efficient farm labourer, and enable him to rise to a good position as a farm bailiff. Another natural group of subjects comprises physics, chemistry, geology, botany, and animal physiology. A boy need not—it would be advisable that he should not—take all these in one winter; he might spread his studies over several winters, and it is a great advantage for the country boy to have such resources to fall back upon in the winter evenings.

There is one subject which must not be overlooked, and that is mathematics. A conclusion based upon my fourteen years' professorial experience at agricultural colleges is that a lad who is fairly competent in mathematical studies is a good medium to work upon. Those interested in the welfare of any young agriculturist should take care that in his school days the study of mathematics is not ignored. The time devoted to acquiring proficiency in arithmetic, geometry, mensuration, and the elements of algebra and trigonometry—the latter really indispensable in the case of surveying—will never be regretted.

#### MODEL FARMS.

We have yet to consider the question of instruction in the practice of agriculture, involving, as it does, personal acquaint-

ance with, and skill in the actual performance of, those multifarious manual operations which make up farm work. Whilst no one will be inclined to dispute the assertion that familiarity with farm practice can only be acquired on a farm, there has probably been no question more widely debated than that concerning the possession, or location, of such farm. Is a farm an indispensable adjunct to an institution in which agricultural education is imparted, or can the student obtain efficient practical training, suited to his requirements, elsewhere? We discuss this question later, but this may be said at present: Years ago much was heard about "model farms," and there was a period after the Great Exhibition when it was thought that the model farm would serve as the chief teacher of the future farmers of the country. Model farms were started—some of them very beautiful—but where is the model farm that ever paid its way? The most useful type of model farm to place before the young agriculturist is the farm which pays its way best. My own idea is that the model farm is the farm that year by year makes the largest profit. How it is worked is another consideration—if it makes the biggest profit, that is the model to put before our young men. The model farm which is conducted as a toy is not only valueless but injurious, because learners will see at such a farm much that would not be tolerated upon a farm that has to be worked on commercial principles.

#### CLASSES OF PEOPLE NEEDING TECHNICAL INSTRUCTION.

A Parliamentary Return<sup>1</sup> made some years ago showed that there were in England and Wales no less than 55,000 farmers who cultivate holdings of between 50 and 100 acres. These 55,000 occupiers may be regarded as, in every sense, men capable of combining practice with science, whilst the same statement may probably be made of most of the 67,000 farmers who occupy holdings of from 100 to 300 acres in extent. If they can get a certain amount of useful scientific knowledge, they are in a happy position to practically apply this knowledge, because their farms are not large enough to enable them, as a rule, to relieve themselves of manual labour. They find it ex-

<sup>1</sup> An Agricultural Return for 1886, presented to Parliament, records for England and Wales:—

Farm Holdings, 50 acres to 100 acres . . . . .	54,937	} 121,961
" " 100 " 300 " . . . . .	67,024	
" " 300 " 500 " . . . . .	11,841	} 16,608
" " 500 " 1000 " . . . . .	4,194	
" " over 1000 acres . . . . .	573	

pedient to take a share in the work of the farm, but at the same time they are men of capital. They belong to a class that may be materially benefited by the result of recent legislation, which has led to the allocation to each county<sup>1</sup> of a sum of money, originally intended for other purposes, but now available for the promotion of technical education.

Below this class we pass gradually into the large class of labourers. Perhaps there is no problem connected with rural education which occasions so much difficulty as that concerning the training of the labourer. It would be unnecessary to offer the labourer's child the same technical education as the son of the occupier of a large farm, for, possessing no capital, he does not need such education. But there are many points in which the education of the labourer's child might be materially improved, whilst the community itself would benefit thereby. Farm work is of such a nature that whoever has to get a liking for it must commence young. It is similar, in this respect, to seafaring. If a lad wishes to become a smart sailor it is futile to wait till he is 19 or 20 years of age before he first walks the deck; he must commence early in life to take an active part in the work of a sailor. So with the farm labourer—he must begin young.

Commencing at an early age, a boy contracts a liking for farm life, and becomes contented with it. Then arises the question: What can be added to this life to give it a greater interest? As a rule, directly the farm labourer has finished his day's work, he has no resource at all. Would it not be possible so to interest and instruct the children of farm labourers as to make them more useful? It seems that it would, and, indeed, at little expense, by means of a system of instruction carried into the heart of the rural districts. This education must be taken to the people; it must be made available in the villages. As an example, there can hardly be a doubt that by means of evening classes an instructor would succeed in interesting boys in the details of machinery. The teacher could, upon a black board, demonstrate such details, and he might borrow ploughs and other implements and take them to pieces so as to show the various parts, and explain the mechanical principles involved—"The Anatomy of the Plough" would form a capital subject for a lecture. Commencing thus, the boys would speedily become interested, and the interest would grow as the teacher led them

---

<sup>1</sup> For details see: "Statement as to the distribution of Beer and Spirit Duties proposed to be appropriated in aid of Local Taxation, in addition to the amount proposed to be paid in aid of Police Superannuation Funds—England and Wales." [C. 6113.]—Eyre & Spottiswoode. 1d.

on to understand more complicated appliances, such as the cream separator, the threshing machine, and the steam engine. By this method he would instruct the boys, teach them to draw working details, and perhaps prepare the way for some of them in time to become inventors. Somebody has said that the whole of the money spent by the Science and Art Department would be well spent if it enabled the country to produce a Faraday. That is perfectly true, and an intelligent grasp of the principles of machine construction on the part of the coming generation of farm labourers could hardly fail to produce useful results in the direction of improvement. All mechanical appliances would, at the same time, be subjected to better, because more intelligent, management, and considerable saving would thus result.

There are many other avenues of instruction that might be opened to the boys upon a farm. They might be taught to take an interest in the life that is around them. It is possible to take up a turnip fly, and to place it before many a farm labourer who has been hoeing turnips for twenty years, and who yet will not be able to say what the insect is. Boys might easily be induced to take an intelligent interest in the insects of the farm, and the offering of prizes for collections of injurious insects would arouse their enthusiasm. Lads pride themselves upon a knowledge of the birds' nests in their districts, and even of the number of eggs in each. If a new direction were given to their thoughts, and they were led to take as great an interest in injurious insects, the knowledge they thus acquired would be serviceable in combating the ravages of these pests. Field botany would form another subject of study, and boys might be encouraged to make collections of the weeds of arable land, and of grasses, together with their fruits and seeds.

But it is necessary to not only interest the boys and girls—we must get at the parents also. To promote this object there should be some properly defined system of education working from a recognised centre. There might be instituted a series of lessons in what might be termed rural economy, which would certainly attract the attention of farm labourers and possibly of their wives as well, and if the older people were secured the children would follow. Practical instruction might be given upon the making of butter, the management of bees, and the keeping of poultry, whilst a lecture or two upon the pig would find attentive listeners. Bees, poultry, and pigs would afford safe staples to work upon. Another suitable subject is fruit culture. In many cottage gardens good fruit trees are going to ruin because their requirements are not properly understood

and attended to. An expert teacher going through the country districts could give demonstrations on the pruning and the general culture of fruit trees, and answer questions upon points of practice. The crops usually cultivated in cottage gardens and allotments could be made the objects of similar instruction.

Some boys have an intuitive liking for and knowledge of farm stock; they know all about horses in their rough way, and others know much about cattle or sheep. Give them a chance of systematising this knowledge, aid them by the knowledge of others, and there is no telling what good might result. Village school children might, very fairly, be taught something about the machinery on the farm, and they might learn to identify the insects which destroy, as well as the weeds which infest, the crops. As bearing upon this point the following extract is quoted from a paper on "Preventable Losses in Agriculture" which the writer read before the Economic Science and Statistics Section of the British Association for the Advancement of Science, at the Manchester meeting, in September, 1887:—

The village school affords an admirable means whereby much useful instruction might be imparted to country lads, to their immediate intellectual benefit and to their subsequent welfare. For instance, attractive object lessons in botany and entomology might be made the means of familiarising boys with the habits and life histories of farm pests, and would foster in them the practice of independent observation, so that in years to come for each pair of eyes now at work there might be thousands. It surely would not be difficult to interest an intelligent village boy in the natural history of wireworms and leather-jackets, of turnip-flies and saw-flies, of birds and insects which help the farmer, and of those which injure him, of the good grasses and the bad, and of notorious weeds and parasites. Yet, whilst the school wall is adorned with pictures of the tiger and the elephant of the Indian jungle, there are none showing the metamorphosis of a click beetle or the structure of a grass. The boy may be taught to draw a map of the unstable frontiers of the south-east of Europe, which are hundreds of miles away, but he is never taught to seek out the ergot which infests the grasses, or to destroy the chrysalids which hang upon the hedgerows, or to recognise the plants of the meadow close to his cottage door. Knowledge such as this might become of much use to him, and render him a valuable and desirable servant in after years; but it is kept from him, and he grows up stolid and indolent, because, during the most impressionable years of his life, our system of education fails to interest and instruct him in matters which will be of the greatest practical importance to him, and most intimately associated with his future labours.

It is scarcely necessary to argue that it is the poorer classes who will most require the assistance of the County Councils, and of other local authorities in a position to aid them. A great work may be done in the rural districts, but it will need to be organised and directed from local centres. The agricultural labourer has always been more or less a problem, and a



somewhat difficult subject to deal with. The qualifications of a good farm labourer need to be much more varied than those of a man who obtains his livelihood by managing a machine or hewing coal. Any attempt that is made to help the labourer must primarily be of such a nature as will render him contented with his country home, and will disabuse his mind of the idea that by going away to the town he is bound to benefit his position. A first step in this direction is to improve his knowledge of those little industries on which much of his comfort depends. This is quite a different thing, however, from advocating what might be called a fine education, for that would only discourage the labourer, and make him like the man of whom it was written—

He could not sow nor reap,  
He was not wise at all,  
For though full many arts he knew,  
He badly knew them all.

#### AGRICULTURAL SIDES OF COLLEGES.

Quite recently, considerable interest has been awakened in the subject of agricultural education, and we are already becoming familiar with the phrase “the agricultural side of University Colleges.” In many of our great public schools there is what is termed “the modern side.” This “modern side” was unknown in the earlier years of the century, and hitherto the “agricultural side” has been unheard of in connection with University Colleges. This will be the case no longer. In various towns in England and Wales—in Leeds, Newcastle, Bangor—“agricultural sides” are being established, and other provincial colleges are preparing to follow suit. The question arises, How far are these colleges capable of affording efficient agricultural instruction? A little consideration will show that they may be admirably adapted to the purpose. In such institutions there is no need, in the case of a given subject, to duplicate the means of acquiring a knowledge of it simply because the students intend to follow different avocations. Very much of the chemistry which is useful to the farmer is useful also to the physician and to the iron smelter. Hence, there is no necessity for one system of instruction in general chemistry for the farmer, another for the physician, and another for the iron smelter, and, so far as they can all study in common, they should do so. Then there is the science of physics, which finds innumerable applications in all industries, and there are other subjects to which the same general rule applies,

In the University Colleges of England and Wales,<sup>1</sup> the mathematical subjects, including not only mathematics itself, but also mechanics, mechanical drawing, and building construction, are efficiently provided for. Chemistry and physics were amongst the first subjects for the teaching of which provision was made when these colleges were established. Botany and geology usually have a well assured place in the curriculum, and are capable of valuable economic applications. In connection with zoology there is room for enlargement. It should be made to include the subjects of anatomy and physiology as applied to farm animals. It might also be associated with a professorship, or lectureship, dealing with comparative pathology. Every day we are learning more and more how closely the diseases of men and of animals are allied to each other, and at the present moment a Royal Commission is inquiring into the relations of tuberculosis in animals to human health. Surveying and mensuration are subjects capable of agricultural application, and are already taught in the colleges; they are necessarily taken as subsidiary branches of engineering, or as portions of the mathematical instruction. But certain other subjects must find a place, if the colleges are to become efficient as centres of agricultural education. Such are agricultural chemistry, book-keeping, commercial knowledge, and statistics, or agricultural economics, whilst in some cases forestry should be added. These could be dealt with by means of lectureships, and then the University College might reasonably be regarded as a well-equipped institution for giving instruction in matters bearing upon agriculture.

### IS A FARM INDISPENSABLE?

The question as to whether a farm is necessary has been anticipated. An illustration will serve to show why it is not necessary to have a farm attached to the College. There is, in London, what was long known as the Royal School of Mines. It has but recently become merged in an institution called the Royal College of Science. It has enjoyed a distinguished career as the Royal School of Mines, and has turned out some of the most eminent mining engineers and practical geologists in the world. There is no mine attached to the school, nor do the students

---

<sup>1</sup> In England and Wales, exclusive of London, Oxford, and Cambridge, there are "University Colleges" at Aberystwith, Bangor, Birmingham (Mason Science College), Bristol, Cardiff, Leeds (Yorkshire College), Liverpool, Manchester (Owens College), Newcastle-upon-Tyne (College of Science), and Nottingham.

work in a mine; but they learn the principles on which the art of mining engineering is based, and they learn them so well that, after spending a certain time subsequently in acquiring practical experience, they come into the front rank of mining engineers. Then, again, we have various schools of engineering. The students in these schools are not, however, engaged in building harbour walls, lighthouses, railways, or Forth Bridges, but they learn in the schools the principles which they afterwards put into practice.

It is obvious that, if the possession of a farm is to be a *sine qua non*, the salutary movement which is now in progress in the provinces can only end in disappointment. Moreover, it would be fatal to the aspirations of the University Colleges, and they would be permanently barred from taking any steps for the promotion of agricultural education. As a matter of fact, the possession of a farm is a mere incidental circumstance, and the lack of it should offer no obstacle whatever. In the provinces, students of the sciences bearing upon agriculture need experience little difficulty in seeing good agricultural practice when they wish. Besides, the course in the colleges would not extend to more than about 32 weeks a year. This would afford the student, both in winter and summer, an opportunity to go on the farm again. It is not good policy to give the practical training and the theoretical instruction together, for it is difficult to successfully combine sustained mental labour with hard farm work. It has been attempted, but not with success. A farm attached to a college is apt to be made a convenient excuse for shirking class-room or laboratory work. Student labour in the field is an expensive luxury to him who employs it, whilst if a student has to earn his college maintenance by the sweat of his brow, his time will be occupied more with earning than with learning.

Reference is often made to the United States in support of the system of working students at an agricultural college the same as if they were reformatory boys. But even in America the practice is on the wane. The following letter from Professor L. H. Bailey, of the College of Agriculture, Cornell University, Ithaca, N.Y., speaks for itself:—

The example of the Michigan Agricultural College, which is the oldest in America, and the chief exponent of the so-called manual labour system, is the best proof of the proposition that, as facilities for instruction grow, the mere manual trainings decrease in extent. That institution still holds to its traditional purposes, and most of its faculty would no doubt disclaim any falling off in the manual labour. Yet such labour has fallen off. It was once thought that every student should labour four hours every day. In my own day, labour was required for three and a half hours until about the

middle, or near the end of my course, when it was dropped to three hours. Later, it has been dropped to two and a half hours for many or most of the students, and students are *not compelled to work every day now*. For these labour hours certain kinds of laboratory practice are substituted, as manipulations in chemistry, veterinary surgery, microscopy, and the like, and the faculty will tell you that this is *manual labour!* It simply shows that new methods are creeping in, and the old are disappearing, even when the new are struggling, as you may say, under repression. And as fast as the new ones creep in, just in that proportion does the college increase in usefulness.

As the University Colleges develop their agricultural sides, the work they do might be supplemented by farmers effecting a temporary interchange of their sons. Here is, say, a farmer in the North, who has a farmer friend in Norfolk or Wiltshire, or some other county, and they both have sons of about the same age: what more suitable than that these two young men should change places for a year? It expands a man's mind if he can see the farming and learn the markets of another district besides his own; and, in an arrangement of this kind, the college-taught student, the son of a farmer, might acquire a great amount of knowledge that would be useful and valuable to him all his life.

#### THE DISPOSAL OF THE GRANT TO COUNTY COUNCILS.

In many counties it has already been decided that a portion of the money accruing from the Beer and Spirit Duties shall go to the aid of agricultural education. It is deserving of consideration as to how far it may be expedient for counties to group themselves together, or how far it may be advisable for each county to work independently. This is really a matter to be determined locally, as it only concerns the agricultural centres themselves. Such centres are being established, as at Leeds, Newcastle, and elsewhere, whilst Bangor has constituted a centre for the last two years. These provincial centres would localise the agricultural interests of the various parts of the country, and would operate against that bureaucratic system which is ever tending towards centralisation. The centres would conveniently influence very considerable areas. The latter object might possibly be effected by commissioning local teachers, who would be appointed, presumably, by the central authority itself in each district. These local teachers should be qualified men, who would be competent to impart technical instruction in the villages and remote rural districts, in a manner not hitherto attempted. In that way would be raised up a local network of agricultural education which would permeate every region of the country. This system would make provision not only for the subjects

that have been previously referred to, but for instruction in such important matters as practical dairying, including butter and cheese making. As already intimated, the County Councils have something to look to as a type, or guide; but it will, no doubt, be prudent to hasten slowly, and not to adopt any scheme until it has been well threshed out.

### THE STATE AND AGRICULTURAL EDUCATION.

A subject of first-class importance is the relation of the State itself to these schemes of agricultural education. With regard to the Board of Agriculture, it is necessary to remember that it has only recently been called into existence. In the Act by which the Board was established occurs the following clause:—

The Board of Agriculture shall also undertake the collection and preparation of statistics relating to agriculture and forestry, and may also undertake the inspection of, and reporting on, any schools which are not public elementary schools, and in which technical instruction, practical or scientific, is given in any matter connected with agriculture or forestry, and the aiding of any school which admits such inspection and in the judgment of the Board is qualified to receive such aid, and the aiding of any system of lectures or instruction connected with agriculture or forestry, and the inspection of and reporting on any examinations in agriculture or forestry.

From this it is apparent that the functions of the Board, with reference to any kind whatever of agricultural education, are of a very extensive nature. The Board may even go so far as to assist such education, which means to furnish funds. But the Board has hitherto had only 5,000*l.* per annum at its command for this purpose. If the Board is to do more work in this direction, Parliament must be asked to sanction the grant of a much larger sum of money to be placed at the disposal of the Board.<sup>1</sup> Moreover, the granting of a yearly sum to the Board of Agriculture must no longer be a matter of uncertainty. It should be a recognised regular occurrence. It is too much to expect those who are managing institutions to raise large sums of money by means of local subscriptions, while each year the Board of Agriculture, if it makes a grant, is compelled to say that it is only a temporary one, and that no claim for its continuance can be based thereon.

It is also specially to be noted that the Board has the power of inspecting and reporting upon every kind of agricultural education in this country. Any body or corporation then, including County Councils, should be required, before spending

---

<sup>1</sup> In the Estimates for 1891-2, a sum of 8,000*l.* has been set down for the purpose indicated.

the ratepayers' money, to submit to the Board the whole of its scheme in connection with education, and show all the facilities it possesses for giving agricultural instruction.

The Act<sup>1</sup> of 1890, which places the various sums of money at the disposal of the County Councils, says that the Council of any County or County Borough may contribute such sum or any part of such sum "for the purposes of technical education within the meaning of the Technical Instruction Act, 1889, and may make that contribution over and above any sum that may be raised by rate under that Act." It does not say "must;" it says "may"—but it is believed that County Councils which disburse the money in this direction will have established a sufficiently good claim to its becoming an annual grant in aid of technical instruction. The Technical Instruction Act, 1889 [52 and 53 Vict. ch. 76], contains the subjoined clause:—

The expression "technical instruction" shall mean instruction in the principles of science and art applicable to industries, and in the application of special branches of science and art to specific industries or employments. It shall not include teaching the practice of any trade or industry or employment, but, save as aforesaid, shall include instruction in the branches of science and art, with respect to which grants are for the time being made by the Department of Science and Art, and any other form of instruction (including modern languages and commercial and agricultural subjects) which may for the time being be sanctioned by that Department by a minute laid before Parliament, and made on the representation of a local authority, that such a form of instruction is required by the circumstances of its district.

These two clauses, taken together, afford a tolerably clear indication as to what the Government desires with regard to these sums of money. More than this, however, the Chancellor of the Exchequer (Mr. Goschen), in reply to a question by the Marquis of Hartington in the House of Commons, on December 4, 1890, said: "If County Councils set themselves heartily to work to utilise the grants for important educational purposes, it will probably be difficult for any Minister to persuade Parliament to divert them." And Lord Hartington, who presided at a Conference convened by the National Association for the Promotion of Technical and Secondary Education, on December 5 last, said:—

Perhaps I may be allowed to supplement the answer of the Chancellor of the Exchequer by a consideration which I think of an important character. It is desirable to remember the source from which these grants come. They proceed from an additional tax placed upon spirits and beer. It is quite possible that a state of things might arise under which these articles would not bear the additional duty, and it would then become a question whether the grant should not be made up from some other source arising from the

<sup>1</sup> Local Taxation (Customs and Excise) Act, 1890. [53 and 54 Vict. ch. 60.]

general taxation of the country. If the grant had been placed to the reduction of rates alone, the question would arise whether Parliament would consider itself justified in imposing a new taxation upon the community to reduce the burden upon the ratepayers. It is impossible to say what answer Parliament might make to such a question; but if this grant should be applied to the establishment of important educational work which would be beneficial to the whole community, it becomes almost morally certain that it would be incumbent upon any Government that might be in power at the time not to deprive the local authorities of the grant. We are, therefore, justified in suggesting to Local Authorities that it would be a shortsighted economy to apply the grant solely to the reduction of the local taxation. The best way of securing the fund will be to see that it is used for the purpose for which it was originally granted, by stimulating existing institutions in the work which they are now doing, by adding a scientific and practical side to schools, and providing new schools where such do not now exist.

#### PUBLIC FUNDS APPLICABLE TO AGRICULTURAL EDUCATION.

The sources from which moneys applicable to purposes of agricultural education may be derived are varied. In the first place, moneys come direct from the Treasury,<sup>1</sup> from which source certain sums of money are allotted to University Colleges. In so far as the normal instruction in these colleges is given to the agricultural student, to that extent must the Treasury grant be regarded as applied to agriculture. The Treasury further subsidises the Scotch Universities. A possible source of considerable revenue is now also to be found in the Education Department. In England the Privy Council, under the New Code of Education, permits of instruction being given in agriculture to children in village schools, and it also permits of the establishment of evening classes in agriculture. In Scotland the Education Office supplies the sinews of war through the Scottish Education Department. Then, again, there is the Science and Art Department, South Kensington, which assists agriculture through its ordinary Science Classes. It also aids agriculture through the medium of Training Colleges for teachers, one of the alternative subjects which teachers in training may take being the Principles of Agriculture. It further assists agriculture through the Normal School of Science, now a part of the Royal College of Science. Another and distinct source is afforded by the Charity Commission, which has control of endowed schools, and several of these endowed schools are occupied at the present time in improving the quality of their

---

<sup>1</sup> Under the operation of the Intermediate Education (Wales) Act, 1889, the Principality is in advance of England. See the Manual on Intermediate and Technical Education (Wales), by Thomas Ellis, M.P., and Ellis Griffith.

agricultural instruction. The Home Office, in its relations to Reformatory and Industrial Schools, encourages a certain amount of instruction in manual agriculture. The Office of Works, in that it supplies funds for the Royal Botanic Gardens at Kew, where regular courses of instruction are given, assists agricultural education. We must, further, regard the County Councils as affording support to agricultural education, because in every county the County Council has power to apply the new revenues derived from the additional Duties on Beer and Spirits, or a portion thereof, to agricultural purposes. Finally, there is the Board of Agriculture, which, during each of the last three years, has expended in Great Britain a sum not exceeding 5,000*l.*, in the form of subsidies to various institutions supplying general agricultural and dairying instruction.

The success of technical education in agriculture must be determined chiefly by the inherent capabilities of those to whom it is imparted. In other words, the profitable application of the results of technical training to the varied problems that day by day present themselves to the farmer, and call for prompt solution, must ultimately depend upon the individual. Probably the gravest mistake that can be made is for a young farmer, when he enters upon his first occupancy, to think that his education is finished. It has really only just begun.

W. FREAM.

---

## MODERN BEE-KEEPING.

THE occupation of Bee-keeping ranks amongst the oldest pursuits, and in the days before the manufacture of sugar it was one of the most important industries, furnishing the principal sweet, Honey, and the chief illuminant, Bees' Wax. Yet there can be no doubt that, at the beginning of the present century, the culture of Bees had fallen to a very inferior state. Hence, it will be of interest to trace the causes that led to the rise and progress of what is now in all parts of the world a growing industry; and one, moreover, which should always be intimately associated with the agricultural and fruit-growing interests.

During the latter half of the eighteenth and the early part of the nineteenth centuries the spirit of improvement was at work,



and many busy minds were occupied, not only in investigating the natural history of the Honey Bee, but in cultivating the Bee in habitations more suited to the increased quantity and improved quality of its Honey. Space is hardly available to give a history of all who in those days laid the foundations of the now fairly perfect system of Modern Bee-keeping. Huber, Réaumur, Bonnet, Bevan, Munn, Nutt, and others, all did work that prepared the way for the practical hives of Langstroth in America and of Woodbury in Great Britain. The perfecting of these Movable Comb Hives must be looked upon as the first great step towards success. For a long time, however, Bee-keeping was far more a hobby than a business. It is true that many enthusiasts took it up and, on a small scale, made it a great success; but it was not until the Bee Keepers' Associations were formed, and practical knowledge was diffused through their agency, that the art began to assume the proportions of a national industry.

To the Americans belongs the credit of the origin of the movement. In the United States, Bee-keeping had already secured a hold upon the people when the Langstroth Hive was introduced. The Americans grasp new ideas much more quickly than we do, and it was the gigantic results achieved in California that opened our eyes to the possibilities of Bee-keeping as a great and profitable business. In California the Honey Bee was unknown, but, as the result of much persevering labour—for this was before the time of transcontinental railways—a few stocks reached there in 1850 *via* the Isthmus of Panama. They, or rather their immediate successors, sold at fabulous prices for a year or two; but, in a land literally flowing with Honey, Bees multiplied in a way that Bee Keepers had never even dreamed of. As a matter of fact, the Honey overflowed from the Hives placed in the sage bush, so that in a very few years the hill-sides became dotted with vast Bee Farms, which then were, and still are, the wonder of the world, for as yet they are unrivalled. A large export trade in liquid Honey was the natural consequence, and at first the produce came principally to this country. Now, owing to the excellent transit arrangements and the low freight rates, it nearly all goes to the Eastern States, where it is regarded as a high-grade product.

The success achieved stimulated similar work elsewhere. Nearly all our Colonies took the matter up, and marked success attended the efforts of Australia and New Zealand. Their product is now quite well known on our markets, and, on account of their favourable climates, they have been far more successful than we in this country. In Britain we can never expect to get

such good results, owing to the uncertainty of our weather, though this difficulty is lessened, in a measure, by bestowing careful management upon our stocks.

There is no doubt that the management in this country is decidedly superior. Our Apiaries are far more tidy and neat than many of the large concerns abroad, which have a neglected and untidy look about them, their Hives not being so well made or so well kept, and the paint-brush being conspicuous by its absence. Our chief difficulty at home has always been the low price at which the imported Honey is sold, this being the commodity which we have to compete with. One feature, however, is greatly in our favour—it is admitted by all authorities that no country in the world produces such delicious Honey as our own. We may not be able to get the quantity, but we can and do secure the quality, and this has been, and always will be, our main support. Honey of high quality is the natural produce of this country, and we have, therefore, only to teach our Bee Keepers how to put it upon the market in the best and most attractive form in order to lift it out of the field of low-price competition; a good article will always fetch its value. The great results achieved in the United States and in our Colonies were in Extracted or Liquid Honey alone, so that we are really without any competition at all in the matter of Comb Honey, the production of which, therefore, should always take the first place.

Only once has any attempt been made to compete with us in Comb Honey. This, however, was on a most notable occasion, and it has never been repeated. It is interesting to the readers of this article as having been in connection with the Royal Agricultural Society's Show at Kilburn in 1879. The Honey Exhibit at Kilburn was a startling one, the like not having been seen either before or since. A firm of American importers claimed to have landed the enormous quantity of 80 tons of Comb Honey in sections. Whatever might be the actual weight, it was undoubtedly a very large lot, and an immense pile was staged at Kilburn in the Bee Department—over two tons, if my memory serves me aright. The advanced British Bee Keeper of that day was alarmed at the prospect of this kind of competition in the Comb Honey business. The lesson, however, had a good effect, and stirred up great energy in the raisers of Comb Honey, the result being that we speedily learnt how to produce the best Comb Honey in sections in the world.

Up to this time Sections and Honey Extractors were comparative rarities, and we must bear in mind that the two above-named articles, with the Movable Comb Hive and Foundation,

are at the bottom of our success. The planks of our platform may be arranged thus:—Movable Comb Hives, Comb Foundation, Extractors, Sections, and, by no means least, Education.

For the last named we are indebted to the British Bee Keepers' Association, as galvanised into life by the Rev. H. R. Peel. To his great efforts, untiring perseverance, and persistent overcoming of difficulties, British Bee-keeping can never cease to be indebted. Though we had another good pioneer in the person of Mr. C. N. Abbott, with his "Bee Journal," still, it is not too much to say that Mr. Peel was everything to the cause of Bee-keeping in that day. He gave time, energy, means, and that too without stint; he clearly saw that the British Bee Keepers' Association must assume the position of a parent, and that every county in Great Britain must become its child, and be educated on this question. He therefore started on the work of forming, in the counties, Bee Keepers' Associations, in affiliation with the Central Society whose headquarters were in London, and at the time of his much lamented death he had in a great measure accomplished the work. In every county the advanced Bee Keepers were sought out and brought together into an association, and then began the work of educating the unskilled Bee Keepers of the county and of inducing all who were connected with agriculture or horticulture to commence Bee-keeping on right lines. The humble cottager was, however, the chief subject of instruction. With the spirit of a true philanthropist, Mr. Peel strove to better the position of the labourer, to raise him by means of his Bees, and to lessen his poverty by his own exertions, so that in being relieved he was not in any way pauperised or a loser of his self-respect. There are numbers of this class spread over the land who have cause to be thankful for the knowledge they gained from their County Bee Keepers' Association.

Experts were engaged, and made visits to every Bee Keeper in the county. Bees were examined and some practical work was done in each Apiary, and, in several of the largest and most successful associations, a census was taken of the number of stocks of Bees. To the local Agricultural and Flower Shows the Bee Tent was sent, and practical lectures with illustrations were given to all who desired to see and to listen. In the very early days of this Tent work great wonder was excited, and the lookers-on would scarcely believe their eyes. When the work was begun in the counties it is scarcely too much to say that it was the custom to kill 90 per cent. of the Bees at the end of the season in order to obtain their Honey.

At present we believe that this fate does not happen to 10 per cent. of them; even the peasant who has not so far advanced as to use the Movable Comb Hive, but still sticks to his straw skip, does not now kill his Bees. He has learnt how to drive them from their Honey without the use of the Sulphur Pit, and the contamination of the Honey by its fumes. He now takes his driven Bees and unites them to his weak stocks. He knows well the value of a strong stock and gets through a bad winter with but trifling loss, whereas in the old time his colonies would be decimated. If, moreover, the summer has been bad, he both unites and feeds in the autumn. His Bees then come out well in the spring and are strong, and the swarming time is therefore early. Then, to avoid loss of his swarms and the trouble of watching, he makes his swarm artificially. To have accomplished all this work is highly creditable to the County Associations. It is true that at the present time they are, to an extent, resting on their oars, but there are various reasons for this. Their active aggressive educational work is, in great measure, finished, and Associations are now doing more in the way of organising Shows for the exhibition and sale of the Honey they have taught their members to produce.

The reproach that the Honey obtained is difficult to sell has often been heard at the Association Meetings. From long experience, however, we know that this is not the case, as we can call to mind many of our best and largest Apiarians whose produce is all bespoke year by year, they having diligently worked and so obtained a name for excellence of product. The Shows, however, have done a good work, for it is well known that the very finest goods are there displayed, and therefore the best houses send their representatives to Shows to buy—hence the very fancy prices we often see written on the sale cards at these exhibitions.

The work of the Associations has further been superseded by the greatly increased circulation of the Bee periodicals. The "Bee Journal," in the hands of Mr. Abbott, was, to some extent, the organ of his own particular business, and Mr. Peel, judging that it would serve British Bee-keeping better as an entirely independent organ, purchased it, and it grew and flourished amazingly. Its success caused other Journals to spring up, all of which were short-lived, with the exception of the "Record," which in the able hands of Messrs. Raitt and Carr took a firm hold of the Northern and Scotch Bee Keepers. Wisely, we think, these journals were brought under the same management, that of Messrs. Cowan and Carr, the one representing the scientific and the other the practical side of the industry. As almost

every Bee Keeper became a subscriber to either the "Journal" or the "Record," and thus got the latest information either weekly or monthly, as the case might be, the work of the Associations naturally became less and less needful, and now only a

*Bar Frame Hive.*

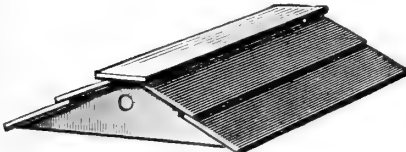

Roof.

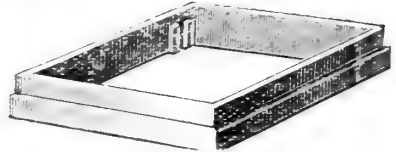

Upper part of upper body.

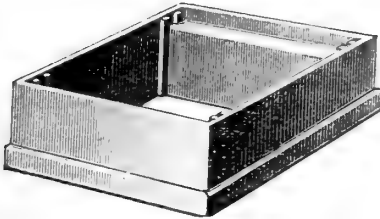

Lower part of upper body, empty.

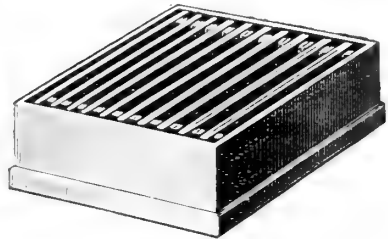

Lower part of upper body, filled with shallow bars.

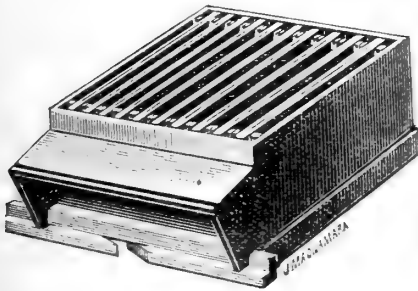

Lower body, with porch and entrances.

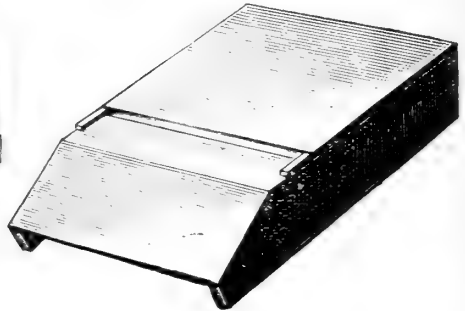

Floor-board.

very few of the still existing local Associations give their members the usual spring and autumn visits of experts.

Bee-keeping is an industry that presents unique features. Its products, Honey and Wax, cost nothing, and if not collected are wasted. The gatherers—the Bees—do their work without payment. The task of looking after the Bees is very light, so that in this business we have labour and material free. All we have to pay for is the supervision of the gatherers, the cost of

the habitation in which they dwell, and the utensils in which they deposit the products. Again, every pound of honey gathered means so much added to the national wealth, as every pound collected here means that much less foreign honey to be imported.

Few persons, even among fruit-growers and agriculturists, think of the benefits that Bees confer upon them. Without the aid of the Bee our fruit crops would, in a great measure, fail, for Bees alone fertilise a very large proportion of the blossoms. The yield of white clover or sainfoin seed is immensely increased if an Apiary is near; and this alone, apart from the profit the Bees yield directly, should induce agriculturists to keep them. One of our largest fruit-growers, Lord Sudeley, has an extensive Apiary attached to his fruit farm at Toddington, and there is no doubt whatever that did he not gain even so much as a pound of Honey per year upon them he would be repaid again and again by the fertilisation of the fruit-tree blossoms through the agency of the Bees, and the consequently greatly increased yield of fruit. We give too little thought to their importance, in so many ways, to our welfare. In olden times so much were their products prized that elaborate laws were framed for the protection of Bees, and pages might be written on this point alone. It is decidedly interesting that in Germany a law has recently been passed which embodies nearly all the old edicts on the subject, and includes strict regulations to prevent the spread of the disastrous disease called foul brood, the microscopic researches into which by Schonfeld, Helbert, Cohn, Cheshire, and Cowan are of surpassing interest, and, though not of such general importance, are quite as absorbing as the investigations of Pasteur and Koch. Within the last year or two, foul brood has also been made the subject of legislation in Canada.

There are many persons who regard Honey simply as a luxury, but it is more than this. It is a most wholesome food, and everyone who values health would do well to take it daily in quantities of two or three ounces. For children it is invaluable, and should always form part of their daily diet, the morning meal being the best time for its use. The trashy syrups of the breakfast table should be banished and Honey should take their place. Some Bee Keepers of our acquaintance eat Honey each morning in their oatmeal porridge in place of sugar, and there is no doubt it is far more wholesome than much of the sugar of the present day. For preserving some kinds of fruit it is particularly adapted, as it has not any tendency to crystallise as sugar often does. Agriculturists know its value as a cattle



Ordinary Section, not folded.

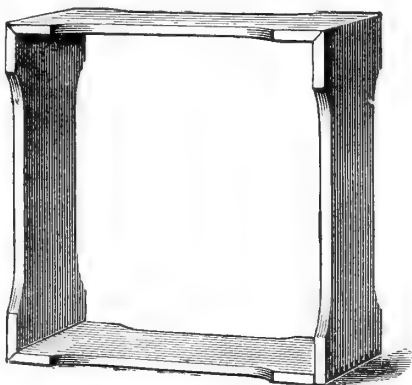

Ordinary Section, folded for use.

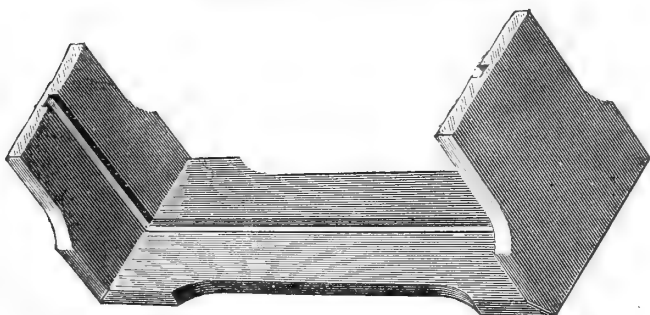

Section with groove all round inside for fixing full sheet of Comb Foundation.

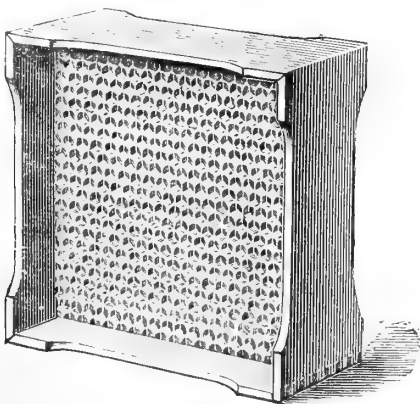

Section, as above, with full sheet of Comb Foundation fixed.

medicine. Our ancestors obtained their strong drink from it, and there are many yet who make their metheglin and mead, and find them better than the drink sold to the public at the present day. As a liqueur, an old mead of, say, ten years of age is very hard to beat.

It will be well in conclusion to give some idea of the implements in use with the Modern Bee Keeper. His Hives are still very much on the Woodbury lines, though many alterations have been made and various neat devices added to render them simple and easy to work. The floor-board should always be easily removable, and should have an ample alighting board. Tastes vary as to legs; they are useful in the winter, but should be removed, we think, when the cold snowy weather is past, and for the remainder of the season the Hive should rest on a bed of dry ashes raised about six inches above the level of the surrounding ground. The Hive should have two bodies with double walls on two sides. The lower body should have a well-spreading porch to shelter the entrance from the sun's rays, and the entrance doors should be so contrived as to open the whole width of the Hive, so that efficient ventilation may be obtained in the hot weather. The upper body should be in two parts, the lower part of the correct depth for shallow frames, as their use is very advantageous. At the same time, if the two parts of the upper body are placed together, they should form a Hive capable of taking the ordinary standard bars. Then, if supering is resorted to, all we have to do is to remove the walls from these upper bodies, when crates of Sections can be tiered one upon the other. The roof finishes off the Hive. Everything should be kept well painted, as dryness is very essential to the welfare of Bees, which were originally natives of a very much drier climate than our own. The Hive illustrations given herewith will show all points alluded to better than pages of explanation.

Sections are an important feature, as by their use we get our Comb Honey in a saleable form. The one-piece Sections are very ingenious, being strips of tough wood  $\frac{1}{2}$  inch in thickness and 2 inches wide, with tenons at each end. Three V-shaped grooves are taken out of each strip, merely a thin shaving being left at the bottom of each groove. When these V-joints are wetted they readily bend without breaking, and the tenons are pushed into each other, a perfectly square strong box being the result. We are indebted to the Americans for this device, and the invention is claimed by Mr. C. E. Parks, who manufactures about 15,000,000 yearly, of which Great



*Super for Bar Frame Hive.*

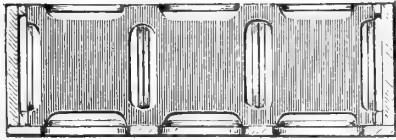
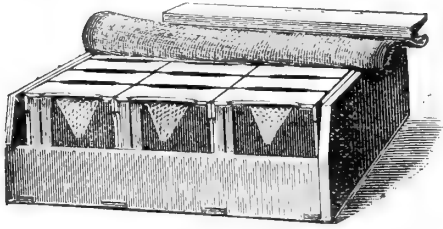

Sectional diagram, showing arrangement of Divider and Sections.

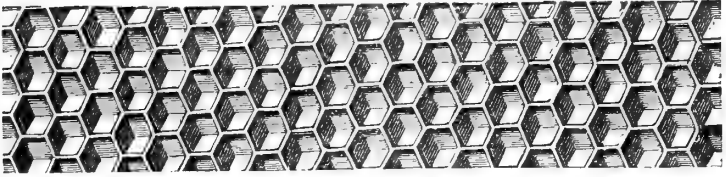

Natural based Comb Foundation.

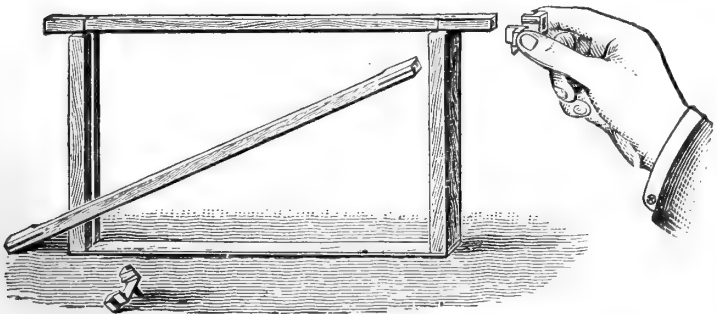
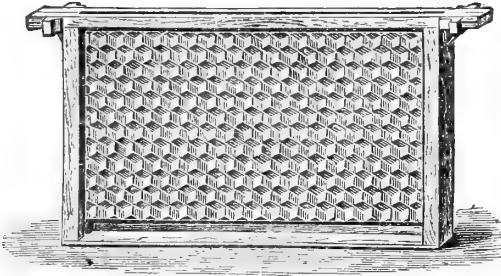

Method of fixing full sheets of Comb Foundation in Bar Frames.

Britain receives about 2,000,000 annually. We are unable to produce them in this country, as we have no suitable wood. The wood used is Basswood (*Tilia Americana*), the American Lime Tree.

The frames both of the Hives and of the Sections must be furnished with Comb Foundation. It is the free employment of this that gives us our large crops of Honey. Pure Bees' Wax is used, and the sheets are produced on roller mills. The illustrations show the devices used for the fixing of the Foundation in both Frames and Sections. In both, simplicity is the great feature.

Next comes the Extractor, consisting of a tin cylinder having revolving cages in which are placed the bar frames filled with Honey. When the cages are then caused to revolve the Honey is thrown out, and the Comb remains in the Bar Frame

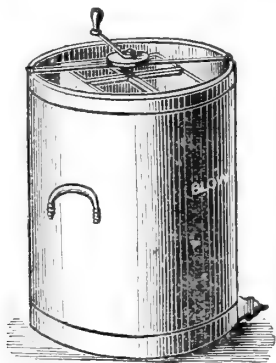

Centrifugal Honey Extractor.

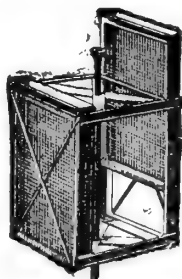

Revolving Cages of  
Centrifugal Honey Extractor.

for further use. It will be seen that a great saving is effected by being able to use the Comb time after time, instead of cutting it up and squeezing out the Honey, as was done in the old days.

To finish the whole we run our Liquid Extracted Honey into clear glass jars, furnished with pretty metal screw caps, and affix to each jar an attractive label. Our Sections we put into enamelled metal cases with glass on each side to protect the Comb from dust, &c., and our work is done.

In conclusion we may say that British Bee-keeping owes much to the Royal Agricultural Society, its annual Shows having for years been the chief meeting-place of Bee Keepers. By the lectures given in its Bee Tents, moreover, many have been induced to join the ranks of those who practise this delightful industry.

## AGRICULTURE AND THE HOUSE OF RUSSELL.

THE death of the ninth Duke of Bedford has deprived the Royal Agricultural Society of one of its staunchest and most distinguished supporters—of one who, though rarely prominent in its public proceedings, filled the office of President in the year 1880, when the Country Meeting was held at Carlisle, and whose memory will be long cherished as that of a nobleman who, with unstinted and continuous generosity, assisted in developing by experimental science the practical resources of the farm. It is therefore but just that special reference should be made in these pages to his worth and work; and advantage may be taken of the opportunity to give some account of other members of his House who were in their time similarly noteworthy as promoters of British agriculture.

It is, of course, simply in the nature of things that the possessors of vast landed estates should be more or less interested in agriculture. In several instances, however, the Earls and Dukes of Bedford have not been content with the general concern indicated by these words—for which, indeed, no credit could be claimed—but have devoted themselves with ardour and enterprise to this great national pursuit.

The first of these to make for himself a name in agricultural annals was Francis, second Lord Russell of Thornhaugh, and fourth Earl of Bedford, who succeeded to the earldom in 1627, and was mainly instrumental in accomplishing for the vast district now known as the Bedford Level that which was achieved for Norfolk a century and a half later by “Mr. Coke, of Holkham.” And in considering his work it should be borne in mind that, although he was possessed of vast estates, their revenues were insignificant compared with the princely income derived from them in these later days. The great estate surrounding Southampton House—on which the Earl’s patriot grandson cast his wistful eyes on his way to the block in Lincoln’s Inn Fields, in 1683—was, as Macaulay tells us, “renowned for peaches and snipes”; but its owner did not dream of the rent-roll now yielded by the squares and streets that occupy its site. We learn, on the same authority, that the Earl’s son, the first Duke, was most reluctant to accept advancement to the highest rank in the Peerage, for “an earl who had a numerous

family might send one son to the Temple and another to a counting-house in the City, but the sons of a duke were all lords, and a lord could not make his bread either at the Bar or on 'Change." To this fourth Earl it was, therefore, by no means a matter of indifference whether an enterprise involving enormous expenditure turned out a success or a failure; but, notwithstanding all the risks attendant upon the undertaking, he was mainly instrumental in setting on foot, and in bringing to an advanced state of completion, a stupendous task, demanding the clearest foresight as well as the highest courage.

Amongst the estates which came into the possession of John, first Earl of Bedford, in the time of Edward VI., was the Benedictine Abbey of Thorney, Cambridgeshire, which had been a religious house since the days of Alfred the Great. In Tanner's *Notitia Monastica*, published at the end of the seventeenth century, the annual value of this property was appraised at 15,240*l.* But when Francis, the fourth Earl—not long released from the Tower, to which he had been sent for having fought with Eliot and his stout compeers for the Petition of Right—succeeded to the title in 1627, he found the 18,000 acres composing the domain a mere waste, the hillock on which the Abbey had been built being the only portion not submerged by water. It seems that at a much earlier period a very different state of things prevailed, for Henry of Huntingdon, writing in the twelfth century, described the surrounding country as "very pleasant and agreeable to the eye, watered by many rivers which run through, diversified with many large and small lakes, and adorned with many woods and islands;" and William of Malmesbury, a contemporary chronicler, described the lordship as abounding in lofty trees, fruitful vines, and productive orchards, and having no waste land in any part. But in 1236, in consequence of a raging wind which lasted for eight or nine days, the sea rose to an unusual height, broke through its banks at Wisbech and other places, and caused great havoc, attended with the loss of many people and cattle. Seventeen years later a similar irruption occurred, and though the breaches in the banks were repaired, under an order from the King, the work was inadequate to prevent further mischief, and the land gradually became reduced to the state of a stagnant and pestilent morass, the water being in some parts from ten to twenty feet deep.

The natural desire to reclaim this land induced the fourth Earl to embark in a still wider undertaking, including the whole of what was formerly called the Great Level, now known (in commemoration of his great achievement) as the Bedford Level, and embracing a tract whose length extends from Toynton

in Lincolnshire to Milton in Cambridgeshire—about sixty miles—whilst its breadth reaches from Peterborough in Northamptonshire to Brandon in Suffolk—nearly forty miles. Wiffen, in his *Memoirs of the House of Russell*, states that the matter had previously engaged the attention of James I., who declared that he would no longer suffer the land to be abandoned to the waters.

Plans were accordingly made, estimates formed, and commissions issued in favour of such as might be willing to commence a general drainage; but disputes arising, the King himself, for 120,000 acres of the waste, became the undertaker of the great work, and invited over from the Low Countries Sir Cornelius Vermuyden to carry his project into effect. Vermuyden obtained for himself and the foreign adventurers whom he persuaded to embark with him in the speculation a grant of this allotment from the Crown. But meanwhile a strong jealousy of foreign intervention became rooted in the minds of the people of those parts, who, in their aversion to the Flemish engineer, earnestly solicited the Earl of Bedford, for the good of the whole country, to become the head and patron of the princely undertaking. Their request was seconded by a court of the commissioners of sewers held at Lynn. Vermuyden's contract was abandoned, and the Earl assented to their call. By a contract entered into on a commission issued by the Crown, and enrolled in the Court of Chancery, September 1, 1630, the Earl was to have 95,000 acres of the inundated land as his return for the expense and hazard consequent upon the drainage. He associated with him fourteen other gentlemen, whom his spirited example allured to take inferior shares, and the work was pursued with extraordinary zeal and perseverance. In 1637 the Earl had expended on the task the immense sum of 100,000*l.* The execution of the work being at first adjudged defective, his grant was restricted to 40,000 acres; but he still persisted in his project with an assiduity suited to his singularly energetic mind, undepressed by the many serious obstacles that impeded its accomplishment. The original grant being renewed at a session held at Ely on March 2, 1653, it was decreed that the magnificent undertaking was completely achieved—a triumph altogether unexampled in the history of British agriculture.

In the words of the historian of the Bedford Level, “a more striking instance of self-devotion to the wishes of the people, and the real benefit of the State, appears not upon the records of history;”<sup>1</sup> and no one will deny that, considering the nature of the enterprise and the risks attendant upon it, the Earl and his coadjutors richly deserved all that they got, especially as we learn from Mr. Pusey's paper in this Journal on the agricultural improvements of Lincolnshire that, “though the body of stagnant water was greatly reduced, still it was not subdued, so that the fen land was worth little, even when George III. came to the throne.”<sup>2</sup> So late as the year 1800 it was stated that more than 300,000 acres in Lincolnshire suffered, on an average, a loss of 300,000*l.* a year for want of efficient drainage,<sup>3</sup> and it was

<sup>1</sup> Wells, *History of the Bedford Level*, Vol. I. p. 106.

<sup>2</sup> Journal R.A.S.E., 1st Series, Vol. IV. (1843), p. 290.

<sup>3</sup> Mr. Albert Pell favours me with the following valuable note: “The effect of the Bedford Level adventurers' work was only to render the land ‘summer

reserved for the engineering skill of the Rennies and Telford, and the mechanical genius of Watt, to complete the great work to which this noble pioneer so determinedly set his hand. But, to use the words of Mr. Froude in one of his *Short Studies*, "if solid work well done, if the addition of hundreds of thousands of acres to the soil available for the support of English life, be a title to honourable remembrance, this Earl ranks not the lowest in the Cheneys pantheon."

The fifth Earl and first Duke, who, as has been shown, was instrumental in carrying out the scheme commenced by his father, survived its accomplishment for nearly half a century—until the year 1700. Passing by his immediate successors in the title, we come to John, the fourth Duke, who succeeded to the estates in 1732, and of whose interest in agricultural matters we have occasional glimpses in his published *Correspondence*, and in the introduction prefixed thereto by his great-grandson, the late Earl Russell. We read of his frequent journeys to his property for the purpose of marking out hedges, planting trees, and letting farms. Planting was with him a very favourite occupation, for the evergreen drive at Woburn was his work; and in 1743 he converted a rabbit warren in the park into the fine plantation, more than 100 acres in extent, known by the name of the Evergreens, to commemorate the birth of his daughter, afterwards Caroline, Duchess of Marlborough. It is related of him that on one occasion, his desire to thin the young trees being resisted by his gardener, who said it would destroy the plantation and injure his professional reputation, the Duke not only carried out his intention, but (with somewhat unmerciful sarcasm) met the objection by putting up a notice-board facing the road:—"This plantation has been thinned by John, Duke of Bedford, contrary to the advice and opinion of his gardener." Of the plantation so formed Mr. Forbes, a later gardener, says, in his preface to the *Pinetum Woburnense*, that many of the Coniferæ may be pronounced as unequalled by any other plantation in the kingdom, and that this may be chiefly attributed to the Duke's judicious thinning during their early growth.<sup>1</sup>

---

land.' In winter most of the reclaimed land was 'bright,' *i.e.*, covered with water. This was, however, all the adventurers pretended to do. It was left to others to obtain complete mastery of the water by forming subsidiary districts under Local Acts, and lifting the water by machinery into the great arterial works of the adventurers."

<sup>1</sup> "The mischief and damage arising to plantations in general from a bad system of pruning, or neglect, induced the late public-spirited Duke of Bedford [Francis] to direct a series of experiments to be made at his expense by W. Pontey, of Huddersfield, on his extensive plantations in the neighbourhood of

We are thus brought to the famous "farming Duke of Bedford," Francis, the fifth Duke, who succeeded his grandfather in 1771, when he was a boy of five, with, humanly speaking, the prospect of a long career of usefulness. This hope was, however, doomed to disappointment, for his life was cut short, in 1802, at the early age of thirty-six; not, however, before he had made his mark as one of the most eminent agriculturists of his time, a worthy contemporary and friend of Mr. Coke, of Holkham. He was instrumental in establishing one of the earliest of our local agricultural societies, and created on his estate a model farm of 300 acres, sparing no expense in supplying it with the most approved buildings and appliances. He also devoted great attention to cattle- and sheep-breeding in a systematic and intelligent fashion. Arthur Young, in his *Annals of Agriculture* for 1795, gives a long and precise account of an experiment set on foot by the Duke in 1793 for the purpose of comparing the growth, at different periods, of 7 Southdowns, 7 New Leicesters, 7 Cotswolds, and 7 Wiltshires, all shearling wethers. In the following year the experiment was repeated with 80 lambs, 20 of each sort. The weights were first taken on November 19, after eighteen hours' fast; then on February 25, 1795, when 4 Wiltshires were discarded, it being found that 16 Wiltshires ate as much as 20 of the other breeds. The 76 remaining sheep were next weighed on May 13; then on July 3, after being shorn, the wool being weighed separately; on October 15, when they were put to turnips; and on February 16, 1796, when they were sent to market. The second-best from each lot was killed and weighed in detail, and the rest were sold. The most minute particulars are given of this experiment, which is described as "a very valuable one." Its result was that the Leicesters were found to be the best, and the Wiltshires "incomparably the worst." Indeed, Mr. Young adds:—

We have to regret that the twenty Wiltshires were not continued through the trial, because in that case the inferiority of the breed would have been more decisively proved; there is reason to suppose that had this been done, they would never have fattened at all.<sup>1</sup>

But one other point remained to be ascertained after the sheep quitted the hands of the Duke of Bedford, and this, it

---

Woburn" (*Trans. Soc. Arts*, Vol. XXIV. p. 8, 1807). Mr. Pontey published two valuable books, *The Forest Pruner, or Timber Owners' Assistant*, and *The Profitable Planter*, on the title-page of which he describes himself as "Planter and Forest Pruner to the late and present Duke of Bedford."

<sup>1</sup> *Annals of Agriculture*, Vol. XXVI. p. 435.

will be seen, was put to a practical test, with an entertaining result:—

The Leicesters (says Mr. Young) have a bad reputation as mutton at the table of a gentleman, and the Southdowns are esteemed amongst the best in the kingdom. Lord Somerville purchased a leg of both these breeds, directing the butcher to cut both in the same form: his lordship gave a dinner, at which the Duke of Bedford, the President of the Board of Agriculture, and other company fond of the good cause were present—I had the honour of partaking it. The legs of mutton were placed on the table at the same time, for the company to pronounce which was the best; and the result was that by much the larger part of the company declared in favour of the Leicester, thinking while so doing that it must be Southdown. The difference in fact, however, was very small; the flesh of the Leicester was of a closer texture, but rather of a paler colour; the gravy of the Southdown of a higher flavour.<sup>1</sup>

In the Charter granted to the English Board of Agriculture in 1793, the Duke, who was then, it must be remembered, barely twenty-eight years old, was named as one of its members, and his attendance at its meetings was as regular as his many avocations would admit. He also took a prominent part in the foundation of the Smithfield Club, presiding at the first meeting held for that purpose, December 17, 1798, and officiating as its President until his death, little more than three years later. His efforts for the improvement of agriculture were, indeed, as unceasing as they were necessary, for at that time English farming was in a very primitive state. We learn from Mr. Bennett's Prize Essay on the Farming of Bedfordshire that in the Duke's early time two-thirds of that county were in common field; a third of the arable land was under a dead fallow every year; the part under crop was wofully damaged by water; the meagre-looking sheep were often swept off in entire flocks by the rot; the neat cattle were of no distinct breed; the farm implements were of the rudest kind. No one who lived in or near his time could, says Mr. Bennett, "be ignorant of the efforts which the Duke put forth to arouse the torpor-stricken agriculturists of his day." But he did not, like his friend and fellow-labourer, Mr. Coke, live to see the triumphs of improved farming, through which, according to the writer from whom we quote, there were in 1857 "scores of farms producing 50 per cent. more corn than in 1794, and supplying the metropolitan markets with a stone of meat for every pound supplied at the former period."<sup>2</sup>

Perhaps the best evidence of this popular nobleman's enthusiasm in the cause of agriculture is to be found in the accounts

<sup>1</sup> *Annals of Agriculture*, Vol. XXVI. pp. 433-4.

<sup>2</sup> See Journal, R.A.S.E. 1st Series, Vol. XVIII. (1857), p. 28.



of the famous Woburn Sheep-shearings. These "sheep-shearings" were far more important than so modest a term would imply, and were in reality important meetings, at which the Duke's tups and ewes were let at certain fixed prices, choice neat stock were exhibited, novel and improved implements were shown, wool was sold, and prizes were awarded to the most successful exhibitors. There were, indeed, all the elements of a modern agricultural show; and to these must be added the unbounded hospitality dispensed by the Duke, who entertained two or three hundred visitors at the Abbey for several days in succession. Contemporary records of these gatherings are full of interest, and we find amongst the names of those present the Duke of Manchester, the Earls of Egremont, Lauderdale, Spencer, and Winchelsea; Lords Sherborne, Preston, and Ludlow; Sir John Sebright, from Worcestershire; Sir Thomas Carr, from Sussex; Sir John Riddell, from Roxburgh; Sir John Ramsden, from Yorkshire; Sir Charles Davers, from Suffolk; Mr. Coke, of Holkham; the President (Sir John Sinclair) and Secretary (Mr. Arthur Young), of the Board of Agriculture; the President of the Royal Society (Sir Joseph Banks); Messrs. Ellman (Sussex), Parsons (Somerset), Westcar<sup>1</sup> (Bucks), Quartly (Devon), Jobson (Northumberland), Buckley and Stone (Leicestershire), Ducket<sup>2</sup> (Surrey), and many others whose patronymics are, or have been, familiar to agriculturists. In the chronicle for 1800 we are told that the call for post-horses and conveyances on the London road was so great that many could not get to Woburn till the business had commenced; others were obliged to go by indirect roads, and then, failing to get conveyances across country, were compelled to walk a number of miles.

The order of proceedings was much the same year by year. At nine in the morning of the first day of the meeting in 1800 the Duke gave a public breakfast at the Abbey, and about two hours later the company proceeded "in a grand cavalcade," headed by his Grace, to "the new farm-yard," to inspect the sheep-shearing, at which "five of the best hands that could be procured" were employed. Thence they proceeded to a building specially erected as an exhibition-room, to see the ewes or tups to be let for the ensuing season. The Duke then opened the

<sup>1</sup> At the Sheep-shearing in 1801 Mr. Westcar received the thanks of the meeting "for the successful exertion of his talents in rearing Leicestershire cattle."

<sup>2</sup> In 1799 the first gold medal of the Board of Agriculture was given to Mr. Ducket for his general merit as a cultivator, and also for having presented his skim-coulter plough to the Board, offering to fix that coulter free of expense to ploughs sent to him from any part of the kingdom.

certificates presented by competitors for his prize of fifty guineas, offered to the person who should, between the previous June and Christmas, have expended the largest sum (not less than sixty guineas) in the purchase of breeding ewes or theaves of "the New Leicester or Southdown breed."<sup>1</sup> About 3 P.M. the company returned to the Abbey, where the Duke entertained some 200 noblemen, gentlemen, and yeomen at dinner in the large hall. Here tables were laid, "which branched out in three directions, but so contrived as to have but one head, at which his Grace presided." On this occasion Prince William of Gloucester (a nephew of George III.) was at the Duke's right hand, and Lord John Russell, his brother, afterwards sixth Duke, "sat as croupier." After dinner the King's health was drunk, and this was followed by a number of toasts and "sentiments," such as "Success to Agriculture," "A Good Crop of Wheat," "The Fleece," "The Plough," "The Memory of Mr. Bakewell," and the like. This occupied the time till six o'clock, when the company again proceeded to the farm-yard, where various attractions awaited them—for example, "a very fine hog, the property of Mr. Pickford, wagon-master, supposed to weigh about 100 stone"; and, on another occasion, "a very extraordinary fat three-shear wether, of the New Leicester breed," 296 lbs. live weight, admitted by the company to be the fattest sheep they had ever seen.<sup>2</sup> In the meantime, the sheep-shearers continued their work "in a place conveniently adapted for the whole of the meeting to see them." After witnessing their performance, the Duke conducted his visitors to the "Evergreens," to see some select Devonshire oxen, and thence to the water meadow, near Birchmoor House, in Crawley Lane, where there were some fine cows of the same breed.

On the second day the tups were first shown, singly, after which sweepstakes of five guineas each, made by the Duke of Bedford, Lord Winchelsea, Lord Somerville, and Mr. Bouverie, for the best two-year-old Devon heifers, were determined in favour of Lord Winchelsea. Mr. Garrard,<sup>3</sup> "the modeller of cattle," then placed before the company his models of the prize cattle shown at the previous Smithfield Show, and of other noted animals; after which attention was directed to improved

<sup>1</sup> At the death of his Grace these premiums were discontinued, in accordance with his avowed intention, as he felt that the object in view—the introduction of these breeds into the county—had been attained.

<sup>2</sup> Details of the weight of this sheep are given in the "Annals of Agriculture," Vol. XXXIII. pp. 317-18.

<sup>3</sup> George Garrard, an animal painter and modeller, born 1760. He practised largely in modelling, and in 1802 was elected an Associate of the Royal Academy. He died at Brompton in 1826.

implements in husbandry, and, where practicable, they were set to work. This occupied the time till 3 P.M., when there was another big dinner at the Abbey; and at 6 o'clock an adjournment was made, as before, to the farmyard, where his Grace's tups were offered for the ensuing season at fixed prices, and when there were two or more claimants the hiring was determined by lot.

On the third, fourth, and fifth days—for the "sheep-shearing" usually extended from the Monday to the Friday inclusive—very much the same programme was gone through. Prizes<sup>1</sup> (amounting to about 125 guineas) were given by the Duke for cattle and sheep, and for ploughing competitions, in which ox-ploughs took part, three oxen being considered as equal in expense to two horses. The conversation at the dinners (at one of which the Duke's cups and other prizes were distributed) was, we are assured, "entirely agricultural," and was not infrequently productive of challenges: as when Mr. Coke<sup>2</sup> "offered a bet of 100 guineas that he would stock 100 acres with Southdown wethers against another 100 acres to be stocked by any four New Leicester breeders"—the respective merits of these sheep being hotly contested at the dinner-table; or when some Herefordshire breeders undertook to produce better cattle than any county in England—a challenge which was at once taken up by Sir Robert Carr on behalf of his county, Sussex.

At the farm, amongst other exhibits shown from time to time, we find "two remarkably fine and fat cows, which had been fattened by poor feed"; and "Mr. Chaplin, from Lincolnshire, exhibited some extremely fine sheep of his own breeding, which were highly approved of." Ploughing competitions usually formed part of the programme, as in 1800, when there were "five different ploughs—namely, a Northumberland, a Surrey or Duckett's, a Bedfordshire, a Norfolk, and a Scotch one—on which experiments were made in sowing turnips, by making the furrows wide apart." At another time, a dressing-machine was produced which "completely dressed a bushel of wheat in six minutes"; or the "capital mill," built by the Duke, and worked by two horses, with two men to supply it, was set to work to thresh corn, which "undergoes every operation—the chaff goes one way, the dirt or dust another," the corn

<sup>1</sup> On one occasion Mr. Garrard exhibited a model of a piece of the loin of a fat three-shear wether, which had taken a premium in the previous year, and we are told that "the fat measured seven inches"!

<sup>2</sup> At the Sheep Shearing in 1799 Mr. Coke offered the Duke 150 guineas for a Southdown ram, and Mr. Arthur Young remarks that this was "an advance in the estimation of that race."

falling into a sack and the straw into a waggon. A double harrow, "to harrow two lands at the same time," was brought from Nottinghamshire; and Mr. Salmon, the Duke's surveyor, produced a drilling-machine, drawn by one horse, to drill seven rows of any kind of seed, and so contrived that, "if the horse went crooked, the man guiding the machine could keep it straight; and, on the contrary, if the horse went straight, the machine could be made to go crooked if required."

No account of these historic gatherings would be complete without a reference to the mechanical genius of Mr. Salmon, whose very name is probably quite unfamiliar to most readers of the Journal, but whose services in the improvement of agricultural implements were of remarkable, and in his day of unique, importance. Robert Salmon was for 30 years, from 1790 to 1821, surveyor to the Dukes of Bedford, and his inventions were one of the staple attractions of the annual sheep-shearings at Woburn. In 1797, the Society of Arts awarded him thirty guineas for a chaff-cutting engine, which was the parent of all the modern chaff-cutters. At the sheep-shearing of 1801, Mr. Salmon exhibited his "Bedfordshire Drill," which became the model of all succeeding drills. In 1803 he showed a plough wherein the slade was replaced by a skew wheel, as in Pirie's modern double-furrow plough. In 1804 he brought out an excellent "scuffler," or cultivator. Two years later, in 1806, he exhibited a self-raking reaping machine, but neither this implement nor a threshing machine shown with it attracted any public notice at the time. In 1808, however, Salmon's reaper was described in *Bell's Weekly Messenger*, and it is a remarkable fact that this early machine embodied all the principles of the modern self-raker, which was not introduced until nearly sixty years later. In 1814 Salmon patented the first hay-making machine, to which modern improvement has added nothing but new details. He received, at various times, silver medals from the Society of Arts for surgical instruments, a canal lock, apparatus for pruning trees, a man-trap, and earth walls; but, perhaps, his most important work was the designing of the Duke of Bedford's Home Farm and estate buildings, at Woburn, all of which were models in their way. This great, obscure mechanician, died at Woburn in 1821, aged 69—*The Gentleman's Magazine*, in recording his decease, speaking of him as "well-known and respected by the admirers of the fine arts and sciences, the inventor of many useful and valuable inventions in surgery, agriculture, and hydraulics."

To the grief of his many friends and of the agricultural world generally, Duke Francis died on March 2, 1802, at the

early age of thirty-six. Charles James Fox, in moving the new writ for the borough of Tavistock, said of him that "to contribute to the welfare of his fellow-citizens was the constant, unremitted pursuit of his life; by his example and his beneficence to render them better, wiser and happier"; and contemporary literature is full of regrets at his "untimely decease."<sup>1</sup> The Board of Agriculture were not slow to bear testimony to the sincerity with which they, "in common with every friend to the improvement of the country," lamented the death of "the most judicious and munificent promoter of the national agriculture in all its branches." The Board resolved that a medal should be struck *in memoriam*, and should be presented in gold to their Majesties the King and Queen, H.R.H. the Prince of Wales, and the Duke of Bedford; and decided to apply to his Grace for permission to have a bust of his deceased brother for their Board-room.<sup>2</sup> In the following year (1803) no difficulty was experienced in raising upwards of 3,000*l.*, the Prince of Wales heading the list with 100 guineas, in order to erect a statue in his honour; and, the work having been entrusted to Westmacott, the bronze statue in Russell Square was the result. It was erected in 1809, and represents the Duke holding some wheat-ears in one hand, whilst the other rests on a plough, with accessory figures, at the base and on the pedestal, of agricultural stock and implements.

But perhaps the most conclusive testimony to his merits is borne by the man who, of all others, was best qualified to appreciate and least likely to exaggerate them—Arthur Young, whose well-known initials are appended to a notice in the *Annals of Agriculture*,<sup>3</sup> from which the following passages are taken:—

The agricultural world never, perhaps, sustained a greater individual loss than the husbandry of this empire has suffered by the death of the Duke of Bedford. The late Duke came to the management of his vast property in 1787, and gave very early signs of that regulated attention to business and order in the enlightened management of landed property which ensured

<sup>1</sup> In a delightfully quaint little *History of Woburn*, published in 1818, a copy of which was kindly lent me by Mr. Charles Howard, is a long panegyric of Duke Francis, accompanied by a series of stanzas, "the spontaneous effusion of an Inhabitant of Woburn," in honour of him and of the house of Russell generally.

<sup>2</sup> This bust is doubtless that by J. Nollekens, R.A., figured in the frontispiece to the *General View of the Agriculture of the County of Bedford*, published by the Board of Agriculture in 1808. It is also figured in the engraving of the "Woburn Sheep Shearing" referred to on page 136, amongst the art objects surrounding Mr. Garrard.

<sup>3</sup> Vol. XXXVIII. (1803), p. 369.

much of the celebrity that followed; but his peculiar fondness for farming was not very manifest till 1793. In July, 1795, I passed four days at Woburn, and then found many signs of a decided attention to agricultural pursuits. The first sheep-shearing celebrated by a numerous company was in June, 1797, and continued to be held in the same month every succeeding year, but with greater increasing numbers and *éclat*, till it became at last by far the most respectable agricultural meeting ever seen in England—that is, in the world—attended by nobility, gentry, farmers, and graziers, from various parts of the three kingdoms, from many countries in Europe, and also from America. Through all this period the Duke was advancing rapidly the improvement of his great farm; increasing and wonderfully ameliorating the breeds of live-stock, in which he was singularly skilled, and highly successful in all his exertions. His system of irrigation was conducted with great felicity of invention, and executed with uncommon energy.

In order that his experiments might be more varied and extensive, and applicable to a more general utility, he engaged a gentleman of most respectable talents to superintend the whole; fixed the plan of an establishment for agricultural education; arranged the idea and determined the execution of a botanical garden and a laboratory, that the improvement and cultivation of his farm might go hand-in-hand with those scientific inquiries which would offer the most precious opportunity to students of every description to avail themselves of all the assistance which liberality and talents could confer. Such an establishment, under the controul of a mind in which extent of views, clearness of understanding, and severity of judgment were happily combined, could not fail of proving of so decided a benefit to the agriculture of the whole kingdom that, much as the Duke of Bedford has been admired for what he effected, it may be safely asserted that he saw but the morning of that fame which would have attended the maturity of his exertions in this first and most respectable path of public utility.<sup>1</sup>

The work so well begun by the fifth Duke of Bedford was zealously taken up by John, the sixth Duke, who, at the sheep-shearing held three months after his lamented brother's death, gave orders that everything should be conducted as on former occasions, the general arrangements being entrusted to Lord Somerville and Mr. Coke, of Holkham, the former of whom presided at the dinners. His Grace felt, indeed, that "in the promotion of agriculture he was treading in the steps of the brother whom he succeeded, and whose memory he cherished with a degree of affection that amounted almost to veneration."<sup>2</sup> Under his direction the Woburn gatherings continued for many years to attract agriculturists from far and near. Indeed, the visitors increased in numbers, for in 1805 there were at the Abbey dinners, on Monday 236, on Tuesday 246, on Wednesday 232, and on Thursday 178. In 1810 the company in-

<sup>1</sup> Vol. XXXIX. of the *Annals of Agriculture* contains a long account of his Grace's husbandry, illustrated with plans, &c., and extending over more than 70 pp., also from the pen of Arthur Young.

<sup>2</sup> "Letter on the late Duke of Bedford," addressed by Sir William Jackson Hooker to Dawson Turner, Esq.

cluded the exiled King of France, Louis XVIII., and several of the *noblesse* who followed his fortunes and misfortunes.

On the last day of this sheep-shearing, Mr. Coke, in acknowledging the toast of his health, remarked on the great advantages which had arisen from such gatherings, and, referring to the exertions made by Sir Joseph Banks in favour of Merino sheep,<sup>1</sup> admitted the service he had rendered to our manufacturers, but thought it could hardly be expected that the breed would be serviceable in yielding mutton to the country, and proposed as a toast, "Sir Joseph Banks, and a fine fleece on a fat carcass." Sir Joseph, in responding, urged that the improvement of the Merino sheep had but just begun, but he anticipated that they were as capable of development as the Lincolnshires or Southdowns, and had no doubt that in a few years the breed would answer all the purposes which its patrons desired. Time has, however, shown that the practical agriculturist was right, and that the sanguine expectations of the great naturalist have not yet been fulfilled.

The sixth Duke also succeeded his brother as President of the Smithfield Club, and continued in office till 1813, when he resigned the post on proceeding to the Continent, but most generously placed at the disposal of the Club the sum of 125 guineas, to be offered annually in prizes, which were subsequently distributed under the name of the "Bedfordian plate and medals." On his return from abroad he resumed the presidency, which he continued to hold until 1821, when he withdrew from the Club altogether, being of opinion that its objects had been fully attained, and that it had no longer any *raison d'être*. The members were, however, opposed to its dissolution, and, after an interregnum of three years, Lord Althorp (afterwards one of the chief founders of the Royal Agricultural Society) became its third President,<sup>2</sup> and inspired its operations with renewed vigour. It is probable that a similar feeling led to the ultimate discontinuance by the Duke of the Woburn sheep-shearings, as advance was made in agricultural practice, and their usefulness was superseded by the formation of numerous agricultural societies.

An excellent idea of the scene at these famous sheep-shearings, as they were held in the days of the sixth Duke of Bedford, is obtainable from a now rare engraving from a painting by G. Garrard, A.R.A.—"the modeller of cattle" already referred to—published in May, 1811, and a copy of which (presented in November, 1875, by Messrs. Eastons and Anderson) is now

<sup>1</sup> It is stated that at the sheep-shearing in 1799 some Spanish wool from sheep bred in England was sold to the wool-staplers at 5s. per lb.

<sup>2</sup> Journal R.A.S.E., Vol. I. 3rd Series (1890), p. 149.

one of the treasures of the Society's collection of pictures. This print shows us in the centre of the picture the Duke himself, mounted on a favourite mare, and inspecting a piece of broadcloth presented by Mr. George Tollett, "of his own Merino growth." Near his Grace stand Lord Somerville, Mr. Charles Gordon Grey, and Mr. Curwen, M.P.; also, H.R.H. the Duke of Clarence (afterwards William IV.), Lord Winchelsea, Sir Watkin Williams Wynn, and Mr. Ellman. Further to the left is a group inspecting a Southdown tup, in the centre of which stands the Marquis of Tavistock (afterwards seventh Duke). In the background is Mr. Northey, M.P., on horseback, inspecting some Swedish turnips presented by Mr. Thos. Gibbs; also, Mr. Astley, Lord William Russell, Mr. Chas. C. Western, M.P., Sir Charles Bunbury, Bart., and others. On the right of the picture are two men shearing sheep, and near them is a group, including Mr. Arthur Young, Sir John Sinclair, Sir Joseph Banks, Mr. Coke, Sir George Osborne, Sir John Sebright, Col. Beaumont, and the second and third sons of the Duke, afterwards General Lord George William Russell and Earl Russell. In order "to commemorate the encouragement given by the late and present Dukes of Bedford to the art of modelling cattle," an artist (presumably Mr. Garrard himself) is represented in one corner as distributing models to the Duke's four infant sons, Wriothesley, Edward, Charles, and Francis John, amongst whom is one, Lord Charles James Fox Russell, who still happily survives to this day. Lord Charles, represented in the picture in a child's frock and a straw hat, became one of the very earliest members of the English Agricultural Society, his adhesion to it bearing date May 26, 1838; and as such he was made a Foundation Life Governor of the Royal Agricultural Society of England on March 5 of last year.

The sixth Duke himself became a Governor of the English Agricultural Society on June 6, 1838, and was one of the first Vice-Presidents of the Society, holding this office until his death on October 20, 1839, at the age of 73. The vacancy thus caused in the list of the Society's Vice-Presidents was not filled until the first General Meeting held after the Charter had been granted (May 22, 1840), when, on the motion of Mr. Raymond Barker, the Duke of Buckingham was appointed.

In addition to his conspicuous services to agriculture chronicled above, it should be added that his Grace is entitled to much credit for his experiments on the produce and nutritive qualities of grasses, the results of which are shown in the *Hortus Gramineus Woburnensis*, a costly folio produced by George Sinclair in 1816, under the Duke's direction, and containing



not only botanical descriptions of the different grasses, but also actual specimens, together with perfect and imperfect seeds, and accounts of their practical value as feed. A copy of the original edition of this work (of which several smaller editions have since been published) is to be found in the Society's library. At another time, when recovering from a severe illness, the Duke directed his attention to the cultivation of heaths, and published the result of his inquiries in a volume issued in 1825, entitled *Hortus Ericæus Woburnensis*. This was followed, in 1829, by the *Salicetum Woburnense*, descriptive of the Woburn willows; and in 1839, the year of this ardent naturalist's death, appeared the *Pinetum Woburnense*. The series also included a description of upwards of 6,000 ornamental plants and shrubs, published under the title *Hortus Woburnensis*.

The sixth Duke had by his first wife (who died in 1801) three sons: Francis, born 1788, who succeeded to the title, George William (father of the ninth duke), and John, afterwards the famous statesman; and by his second wife, seven sons (one of whom, Lord Charles James Fox, born 1807, still survives) and three daughters.

Francis, the seventh Duke, worthily supported the traditions of the family for agricultural inquiry and improvement; and he was fortunate in possessing the intimate friendship of the third Earl Spencer, whose agricultural biography has already been given in the *Journal*.<sup>1</sup> Their tastes in agriculture, politics, and rural sports were the same; and both are equally entitled to honourable fame for their efforts in improving the labourers' cottages on their estates. One who was in a position to know the facts said at the meeting of the Bedfordshire Agricultural Society in 1860 that "the highest honours that would be associated with the name of the seventh Duke of Bedford," then just appointed to the Lord-Lieutenancy of the County, "are those that he has gained for himself by the attention he has drawn, the example he has set, and the work that he has done, in advancing the welfare of the labouring classes through the instrumentality of their dwellings. The name of Bedford—whether applied to the title or the county—has long been honourably associated with improved agriculture; but it was left to the present possessor of the title to find out a crying evil, and apply the proper remedy." The Duke was, indeed, a most just and excellent landlord, granting long leases at moderate rents. He built most of the well-arranged farm homesteads and cottages which everywhere adorn the estate,

---

<sup>1</sup> *Journal R.A.S.E.*, Vol. I., 3rd Series, (1890), p. 138.

and carried out a splendid system of drainage on all his clay soils. At a time when the over-preservation of game was fashionable he set his face against it, and, although keeping the shooting in his own hands, he gave his tenantry liberty to course the hares. In his time the "Park Farm" was admirably managed, the turnip husbandry especially being of the highest order. (The arable land has since been laid down to grass, and thrown into the Park). He kept a splendid herd of Herefords, and a magnificent flock of Southdowns, and for many years there were at the Park Farm, Christmas sales of some of the finest bullocks, sheep, and pigs the country could produce.

In 1819-51 the Duke gave facilities to Mr. Lawes and Dr. Gilbert for some interesting experiments on the fattening of oxen, the results of which were communicated ten years after to the Society's Journal.<sup>1</sup> The Duke placed at the disposal of the experimenters, for the purposes of this inquiry, his numerous feeding boxes and fattening oxen at the Woburn Park Farm, the special advantages of which were the selection from and dealing with large numbers of animals, and the facility afforded by the box system for the collection and preservation of the manure—to determine the quantity and composition of which constituted an important object of the experiments. The Duke became a Governor of the Royal Agricultural Society on succeeding to the title, and maintained his association with it until his death at the age of seventy-three, in May, 1861, when he was succeeded by his only son, William, the eighth Duke, born in 1809.<sup>2</sup>

The eighth Duke was always more or less an invalid; and a large share of the management of the family estates thus fell upon his cousin and heir presumptive, Francis Charles Hastings Russell, eldest son of Major-General Lord George William Russell, G.C.B., second son of John, 6th Duke of Bedford, K.G. Lord George William Russell was for some time Envoy Extraordinary and Minister Plenipotentiary at Berlin; and thus his family were chiefly educated abroad. Mr. Hastings Russell, as he was called, served for a time in the Scots Guards, and became in 1847, at the age of twenty-eight, Member of Parliament for Bedfordshire, a position which he retained until his succession to the Dukedom,

<sup>1</sup> Journal R.A.S.E. 1st Series, Vol. XXII. (1861), p. 200.

<sup>2</sup> For the explorations in the British Museum and other mines of information relating to the past, which have resulted in the unearthing of so many interesting facts as to the earlier Dukes of Bedford, I am chiefly indebted to the literary acumen and assiduity of my friend Mr. Francis Ford. My sources of information as to the ninth Duke are too numerous to be here chronicled; but my thanks are especially due to Sir John Lawes, Mr. Dent, Mr. Charles Howard, and to the past and present managers of the Woburn Experimental Farm, Messrs. Malden, Fraser, and Elliott.

on the death of his cousin in May 1872. Although he did not take an active share in the debates in the Commons during his Parliamentary career, "never had constituency," writes a Bedfordshire elector to me, "a more exemplary member."

In 1872, Colonel Kingscote, C.B., M.P., then, as now, a very active Member of the Council of this Society, made a special effort to obtain new subscribers to the Society amongst his Parliamentary colleagues; and one of those whom he induced to join was Mr. Hastings Russell. Almost immediately afterwards the eighth Duke died, and the new Duke took up the Governorship which has been held by the head of the house of Russell ever since the Society was formed.

Very shortly after, in June 1873, his Grace was elected a Member of the Council to fill the vacancy caused by the election of Lord Kesteven as Trustee; and he speedily took an active share in the business of the Chemical and Education Committees, of which latter he was elected Chairman in 1874. He held the post of Chairman of the Education Committee until he succeeded to the Presidency in 1879, and it was chiefly owing to the efforts of His Grace and of Mr. Dent that the Society's scheme of Junior Scholarships was promulgated in 1874.

The Duke was elected a Vice-President of the Society in November 1874, on the death of the Earl of Egmont; and when the Society's Jubilee was celebrated in June 1889, he was elected a Trustee. He was chosen to succeed H.R.H. the Prince of Wales as President of the Society after the Kilburn Meeting in 1879, and retired from the Presidential Chair at the conclusion of the Carlisle Meeting in 1880—memorable for the deluge of rain, no less than 2·78 inches falling in the four days, Monday to Thursday, so that at one time the swollen Caldew, a tributary of the Eden, threatened to inundate the Show-ground. In 1874, when the Society pitched its tents at Bedford, the Duke gave 1,000*l.* to the Local Fund, and took great interest in the proceedings. In 1878 he was elected President of the Smithfield Club. Of late years his Grace has not often been seen at the Meetings of the Royal Agricultural Society in Hanover Square; but his interest in the Society's welfare continued unabated to the last, and its affairs were often the topic of conversation between him and his contemporaries on the Council.

It is, however, in his munificent endowment of the Woburn experiments that the Duke's connection with agriculture will be chiefly remembered. In the spring number of the Journal of this Society for 1875, Mr. (now Sir John) Lawes had written an article on the estimated value of manure obtained by the

consumption of different articles of food, which attracted great attention at the time, and which acquired still greater importance after the passing, in the same year, of the Agricultural Holdings Act of 1875, which provided for compensation to outgoing tenants for the unexhausted value of purchased food being subject to arbitration. The late Mr. Charles Randell was not satisfied with the results announced by Mr. Lawes, and on November 3, 1875, the Council, on his motion, carried a resolution requesting the Chemical Committee to consider the propriety and the manner of instituting a series of experiments "by practical farmers in different districts" to ascertain the actual manurial value of the kinds of food most extensively purchased.

At the instance of the Chemical Committee, this reference was extended by the Council on February 2, 1876, "so as to enable the Committee to obtain the opinion of practical and scientific witnesses as to how far the knowledge we already possess of the fertilising properties of manures and feeding stuffs, especially the latter, can be relied upon as a basis of valuation to be made under the compensation clauses of the Agricultural Holdings Act." Thereupon the Chemical Committee at once proceeded to take evidence, and the witnesses whom they examined on February 3, 4 and 28, included Mr. Lawes, Mr. E. P. Squarey, Mr. (now Sir) Jacob Wilson, Mr. Thomas Huskinson (then President of the Surveyors' Institution), Mr. Benj. Bomford (a neighbour of Mr. Randell's), Mr. Randell himself, Mr. James Martin, Major F. L. Dashwood, and Dr. Augustus Voelcker.

The evidence taken by the Committee was subsequently published by the Society in a closely-printed octavo pamphlet of 132 pages, which contains a large amount of still interesting reading. The Duke of Bedford was a member of the Committee, and although there is no formal record of it at this stage, it is evident that he had made known his willingness to allow experiments of the kind contemplated to take place at Woburn. Mr. Lawes referred in his evidence (Q. 162) to a scheme which he had drawn out for the Duke for ascertaining the manurial value of decorticated cotton-cake as against wheat; and the Chairman of the Committee, Mr. Wells, in reference to a suggestion by Mr. Squarey as to the inauguration by landowners of a series of experiments which would carry out and amplify the Rothamsted experiments, said (Q. 335): "We have had an offer from the Duke of Bedford; and I think it is very likely that if an experiment is settled upon there would be an offer of something of the kind you speak of." On Feb-

ruary 28, 1875, when the Duke was present, the late Dr. Voelcker, in reply to a direct question from the Chair, said (Q. 1033) he thought there would be great difficulty in carrying out "practical" experiments of the kind proposed in different places; that it would be better to begin with one experimental station and prove by experience the utility of such experimental stations, and then to extend them to other parts of the country; and that he should like to see one thoroughly well-established and well-conducted experimental station on land differing as much as possible from that at Rothamsted.

In the course of the inquiry and the discussion which arose in connection with Mr. Randell's motion, it appeared to be generally considered that further experimental evidence on the subject might be of much value; but it was at the same time decided that the probability of obtaining sufficiently accurate and applicable results in that way was not such as to justify the Council in making a grant for the purpose. The Chemical Committee reported in April 1876 that they felt "they would only be justified in recommending experiments, the results obtained from which would be held by a general concurrence of opinion, scientific and practical, to be thoroughly exhaustive and worthy of confidence." But they added: "An opportunity for carrying out experiments has been offered to the Society by the Duke of Bedford," and they therefore recommended "that Mr. Lawes and Dr. Voelcker be requested to draw up a scheme for carrying on at Woburn such experiments as they, in conjunction with the Chemical Committee, may determine on."

In this way originated the now famous Woburn Experimental Farm. The Duke expressed his wish that the experiments should be conducted at his own cost, and he offered to give up for the purpose Crawley Mill Farm, comprising about 90 acres, with the house and buildings. On examination, it was found that there was no suitable area on that farm, sufficiently even in character and in condition of soil, as to render it available for a considerable series of comparative experiments. Eventually, after inspection of many others, a large field of 27 acres (Stackyard field) of much more suitable land was selected on Birchmoor Farm; and his Grace with characteristic energy at once made arrangements with the tenant to give it up for the purpose, paying him compensation on the most liberal scale. Crawley Mill Farm has however been also retained, as a means of providing the requisite buildings, a residence for the manager, and the opportunity of having at command the necessary horse and hand labour for the experiments.

The experiments commenced in 1876, and up to November 16, 1877, the Duke had advanced 4,500*l.* on their account. Since then they have involved his Grace in an expenditure of not far short of 1000*l.* a year.

Although the heavy cost of these experiments was borne entirely by the Duke, and although he took the greatest interest in their establishment and progress—for he seldom or never went to Woburn without paying one or more visits, unannounced and unattended, to the experimental plots—he scrupulously abstained from interference. At the same time, he was always more ready to extend than to curtail the investigations, and frequently desired to be informed of anything required in connection with them, in order that it might be at once provided. While thus open-handed and generous, it was only in a most quiet and retiring way that he allowed himself to appear as connected with the experiments; and, indeed, he objected to mention being made of the Society's indebtedness to him.

The field experiments have now reached a stage at which their future progress will be of even greater interest and importance than before, both in a scientific and a practical direction. The land, which at one time it seemed impossible to exhaust by continuous crop-growing, now shows signs of that exhaustion, and of an approach to the limit of the efficacy of manure applied in the past. Valuable confirmation—but on different soil—of the Rothamsted inquiries respecting the continuous growth of wheat and barley is, however, forthcoming; and experiments on the laying down of land to permanent pasture are approaching a point at which the results of comparative treatment will become manifest. In the clover experiments, however, there is much still to learn in connection with the problem of "clover-sickness." The Duke's grant of the land and farm has also enabled the Society to carry out a yearly series of feeding experiments on both bullocks and sheep, the results of which, in view of the increasing importance of stock-rearing, will be of particular value.

The late Duke was a firm believer in silage as food for all kinds of stock, and at considerable expense instituted a series of experiments in relation thereto at the Heath Farm, Woburn. He took special interest in these experiments, and on four or five days after the opening of the silos, at which he was present, he visited the farm, carefully inspecting the cattle under experiment, and keenly examining their general condition. The system resolved upon by his Grace is now regularly carried out, and only last year he had a number of silage stacks made from the grass in the park. During the past winter the deer have been

fed almost entirely upon silage, and the stockman states that they prefer it to hay.

His Grace was particularly proud of his Jersey herd, and was an excellent judge of the breed. The herd was good throughout, and included many animals which would have been highly placed at the leading shows. Though he would never allow them to be exhibited for prizes, many will remember the evident pride with which they were occasionally paraded for inspection. He had the most accurate accounts kept of the weight of milk from each cow; and his dairy was justly regarded as a model. He was also very fond of Jersey beef—a too expensive luxury for most people—and considered its flavour superior to that of any other breed. On one occasion, he sent to Mr. Fraser, the manager of the Experimental Farm, a couple of sirloins of beef—one being Scotch and the other Jersey—with a note to the effect that, after tasting the two, he felt convinced that Mr. Fraser would become a convert to the Jersey beef. The Jersey bullocks and the West Highland cattle formed a very picturesque contrast in the Park, which, says Mr. Dent, “was the most evenly grazed and the best kept, both as to absence of weeds and neatness of roads, I ever saw.”

In all the details of farming operations the Duke took great pains to be well informed, and was, indeed, in every sense a practical agriculturist as well as a great landowner. The late Dr. Voelcker once said that he thought the Duke possessed the best knowledge of the details of farming of any nobleman in the country. Whilst about the land, it seemed as though his greatest interest was in matters relating to farming, and he was always well up in any question—no matter how small—that was under discussion in the agricultural papers and elsewhere. In going round the experimental plots, he was always anxious to know what was the opinion of farmers as to the prospects for the year, and what the probable prices and yields might be. This was particularly the case during those years when he was remitting large portions of the farm rents. He was, too, very open-minded—ready to apply well-considered theories to the test of practice, and to give them his support if he could depend on the reputation of the men by whom they were advanced, though he was sure to sift the matter, as far as possible, before coming to a decision.

The Duke was an earnest friend to education, and erected several schools in various parts of his estates—those at Husbourne Crawley, Ridgmount, and Steppingley, to which he frequently took his visitors, may be cited as examples. He was also careful to provide gardens and allotments for the labourers.

His courtesy to all was proverbial, for he would not enter the humblest cottage on his estate without removing his hat, and no one who recognised him was allowed to pass without reciprocal acknowledgment. No detail in the management of his estates was too small for him to go into personally. He had an excellent memory, even for statistics, and those who had business relations with him had to be very careful in their conversation if they desired not to be caught tripping.

Perhaps no one ever cared less for high rank and great wealth; and the simplicity of his tastes, and his dislike of display, gave to the public an altogether erroneous view of the generosity of his disposition. In his early life he had not been very near the title, nor was his own family wealthy; and he retained to the last in his personal habits the simplicity of a poor man. He would sometimes observe that he had lived upon all incomes, from 200*l.* to 200,000*l.*, and that he could do so again. To say that the demands on his purse, real or pretentious, were unceasing, is but to state that he shared the privileges and penalties entailed by the possession of great wealth on all who have to dispense it. But he was very tender to the poor and needy, and was always willing to assist, and to assist liberally, any good work that had a just claim on his sympathy and help. The necessary inquiries having been made and satisfied, the general direction was to send a remittance, "but with no name," and the extent of his benevolence in this anonymous form was doubtless very great. The town of Bedford, in particular, has reason to be grateful for his constant and generous help, abundant evidence of which is to be found as one passes through its streets.

One of his intimate friends, Professor Jowett, the Master of Balliol College, Oxford, has, in a sympathetic memoir appearing in the *Spectator* of March 7, 1891, thus summed up in powerful language the charitable instincts of his Grace:—

His acts of munificence were princely. He built a great many churches and schools, certainly not from the motive which is said to have impelled great men of old to the performance of such works. He liked to do for others what they were unable to do for themselves; to try, for example, experiments in agriculture which were beyond the means of ordinary persons. Yet he never valued himself on his good deeds, but would rather apologise for them. Sometimes, when he gave hundreds and thousands, he would assume the character of the receiver rather than of the conferrer of a favour. He was often believed, and sometimes believed himself, to be a pessimist; but his pessimism or cynicism was not inconsistent with the most careful fulfilment of his duties to others. In him these qualities never obscured the fine discrimination, the just allowance, the kindly sympathy, the intense compassion for *les misérables*, which in his best moments, when he was quite sure of being understood, he gave proof of in word and deed.



Mr. Dent writes: "The Duke was a very kind host, wonderfully well informed on many subjects, and with a great deal of humour underlying a rather peculiar manner. When he entertained the foreign visitors at Woburn during the Kilburn week, his felicity and facility of expression, in German, French, and English, struck every one with surprise." Mons. Jules Laverrière, of the Société Nationale d'Agriculture de France, writes to me in the same strain, with a vivid remembrance of his Grace's urbanity and hospitality on the occasion referred to by Mr. Dent. Similar testimony is forthcoming from those who attended the admirably arranged excursion of foreign visitors to Woburn during the year of the Indian and Colonial Exhibition in 1886. In fact, as the Master of Balliol observes, "it is not too much to say of him that he was one of the finest gentlemen in Europe. In his own house he took extraordinary care of his guests, and they went away delighted with him."

The graceful tribute paid to the memory of the late Duke by the Earl of Ravensworth, as President of the Royal Agricultural Society, at the first meeting of Council held after his Grace's decease, is printed *in extenso* in another part of this number; but room must also be found in the Journal for the final sentences of the *éloge* of Professor Jowett, as summing up in a few masterly words the leading characteristics of the Duke's character:

He never gained distinction because he never sought it. He would have been the first to ridicule the notion that he would be remembered a century hence. He was disinterested and unambitious, altogether free from the prejudices of rank or wealth, not without a considerable touch of genius in his nature. But he was a spectator, not an actor, on the theatre of the world. He would not have cared to be numbered among famous men. To be ignored was what he would have preferred. Yet there are a few persons for whom he did care, who will always remember him, as long as they live, to have been a highly accomplished man of a singular goodness and kindness of heart, and unlike anybody else whom they ever knew.

Immediately after his accession to the title in January of this year, Francis, the 10th Duke of Bedford, with the public spirit that has always characterised his House, spontaneously expressed his wish to provide for the continuance of the experiments at Woburn which had been inaugurated by his father, the late Duke; and the Society is thus happily able by his Grace's munificence to contemplate without anxiety the progress of a work not only valuable in itself, but of the highest importance to agriculture and to the country at large.

ERNEST CLARKE.

## Official Reports.

### ANNUAL REPORT OF THE ROYAL VETERINARY COLLEGE

*On Investigations carried on for the Royal Agricultural Society  
during the year 1890.*

IN presenting this Report to the Council of the Royal Agricultural Society, the first duty of the writer is to recognise the importance to veterinary science of the munificent grant of 500*l.* per annum for the purpose of founding a Department of Comparative Pathology and Bacteriology at the College. By the aid of this grant a completely furnished laboratory for research has been established, and has for some months past been in full operation. The effects of the action of the Royal Agricultural Society extend far beyond this immediate outcome. An impetus has thereby been given to the whole system of veterinary teaching, as exhibited in the vastly improved accommodation for students and the greatly increased facilities for demonstration which the new offices at the College afford.

As our knowledge of the part played by bacteria in the rôle of nature is extended, we recognise more and more the importance of acquiring information about their life-history, and especially so in the case of those which must be classed as pathogenic (disease-producing) or septic in their action after they have effected a lodgment in the tissues of an animal. The revolution in the practice of the physician, surgeon, and veterinary surgeon during the last twenty years will not be so much wondered at if it be kept in mind that all the loss and disappointments caused by the following diseases may be traced either directly or indirectly to the action of micro-organisms or bacteria—viz., tuberculosis, contagious pleuro-pneumonia, diphtheria, cholera, swine-fever, rabies, glanders, typhoid fever, anthrax, tetanus, leprosy, besides a whole host of others, which at present we can only rank as being probably caused by bacteria.

A concise account of the new Laboratory will be a fitting introduction to the Report of the work which has been carried on during the past year :—

The laboratory is situated on the north side of the quadrangle of the Royal Veterinary College, and consists of three rooms—viz., the preparation room, the microscope room, and a photographic dark room.

In the preparation room morbid specimens are received, dissected, hardened, and sectioned, or otherwise prepared for examination in the microscope room; and when suitable results have been obtained they are recorded for future use, if need be by means of photography, in the third or dark room.

The atmosphere is full of bacteria or germs; but fortunately the pathogenic organisms bear but a small proportion to those which seem to be harmless in their nature. Nevertheless, the fact of myriads of such organisms being present in the air renders the investigation of bacterial diseases both tedious and difficult, on account of the liability to atmospheric contamination

Fig. 1.—Steriliser with Reservoir.

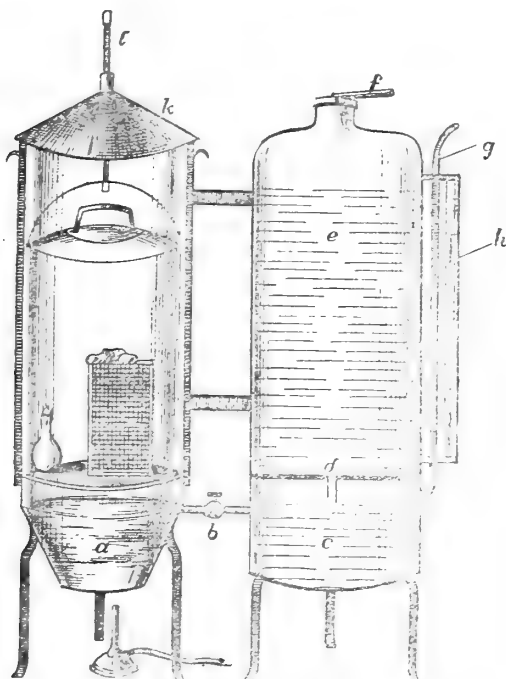

*a*, water in steam chamber; *b*, supply tube; *c*, lower chamber of reservoir; *d*, communicating pipe; *e*, reservoir; *f*, air-tight cap with lever for filling reservoir; *g*, air tube; *h*, water gauge; *i*, thermometer; *k*, felt-covered lid.

taking place during the necessary manipulations. It has been found that bacteria are unable to survive the action of heat, and when this can be applied in a moist form a much lower temperature and a shorter time will be required to kill them than if dry heat had been employed. When by this means (or otherwise) freedom from these atmospheric interlopers has been secured, our instruments and apparatus may be considered in a fit state for further use—*i.e.*, sterilised. Fig. 1 will give some idea of how this is carried out; the vessel to the left is the well-known steriliser invented by Dr. Koch, and the suggestion that to Koch's steriliser should be added the reservoir was first made by Dr. A. P. Aitken, of Edinburgh.

When the steriliser is prepared for use, the tubes, flasks, or instruments are placed in a suitable vessel and lowered into the steam chamber; a Bunsen burner is applied underneath, and in a few minutes steam rises, and can be maintained as long as may be required; the water which has evaporated being automatically replaced from the reservoir through the connecting tube (b). When the contents of a flask or tube have by this means been made pure or sterile, they can be kept so by simply plugging the orifice with cotton wool, which is found to act as a filter to the air which may pass through it.

In practice it is found that micro-organisms may be cultivated upon various media, such as the cut surface of a potato, a slice of beetroot, bread paste, and blood serum; but by far the most useful medium is the peptonised extract of beef and gelatine, so well known to all workers in this branch of scientific investigation. It is now usually made in considerable quantities, and kept ready for use in large flasks, an ingenious arrangement of which (shown in fig. 2) enables it to be drawn off into small tubes.

Fig. 2.

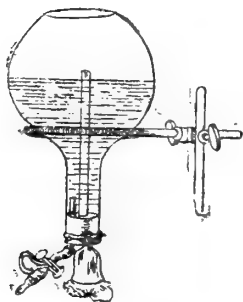

This is also the method of obtaining deposits from milk. The cream, rising to the top, leaves any sediment in the neck of the inverted flask, from which it may be easily withdrawn by means of the tap. Urinary deposits may be obtained in the same way.

Many of these organisms or germs require a higher temperature than that of our atmosphere for their cultivation, and when an investigation is being made into their action and effects on the tissues of an animal, it is needful to cultivate them at the same temperature as the animal's body.

For this purpose incubators are employed very much after the fashion of the "Artificial Mother" so well known to all interested in poultry, the source of heat being regulated automatically. The incubators in this case, however, are specially fitted up to receive tubes, flasks, and plates instead of eggs and chickens.

During an investigation into the cause of an outbreak of disease among cattle it may be found requisite to grow hundreds of these minute fungi in test-tubes and upon all of the media already mentioned, before the particular one which has caused the mischief can be discovered. Even when this stage has been reached we are only upon the threshold of our investigation, for it must be further determined how this organism propagates itself, under which of many conditions does it best thrive; its variations of form under each of those conditions must be registered, so that in future outbreaks it may be more easily recognised. After all this has been accomplished it still remains to be investigated how this disease-producing germ has obtained an entrance into the animal, how it caused the lesions which may be discovered in the various parts of the carcass, and, again, the naked-eye and the microscopical appearance of these parts must be fully and accurately described. It is proved beyond doubt by many failures that we must not rest content with doing all this once only; again and again has the whole procedure to be gone through, and varied so that errors of judgment and of manipulation may be eliminated before the result can be made public.

When it is necessary to examine the diseased carcass, a post-mortem examination is made, and, as has been already stated, the naked-eye appearance, size, and weight of the various organs are placed on record; then portions of these organs are prepared for a further examination under the microscope by being hardened in "Muller's fluid" or in alcohol. If the

Fig. 3.—Photo-micrography.—Condenser, Lime Jet, and Microscope, with Camera attached.

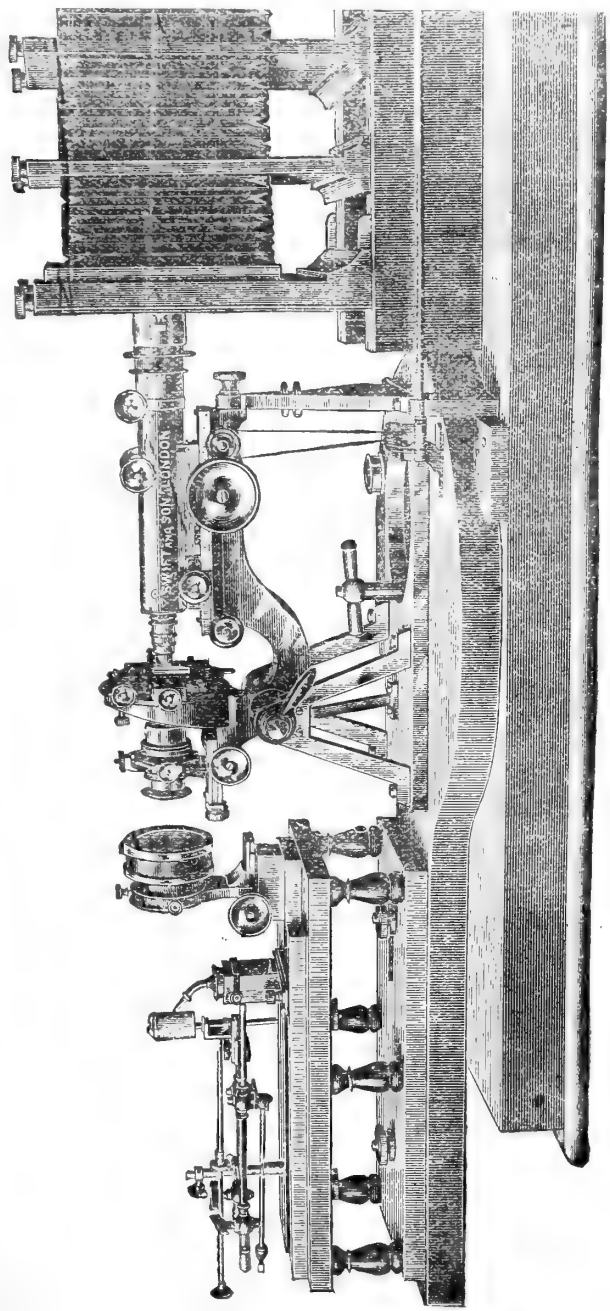

lesions have to be localised, or if their extent in an organ has to be noted, slices or "sections" of exceeding thinness are cut from it by means of a Hamilton-Bruce microtome; this instrument enabling us to obtain them of any size up to  $13 \times 9$  inches.

These sections, after being submitted to the action of various staining reagents, whereby the diseased portions are differentiated from the healthy, are mounted between two thin glasses and transferred to the microscope room for examination; but it should be kept in mind that such large sections are not always required, and as a rule much smaller ones, which can be cut about the  $\frac{1}{2000}$  part of an inch in thickness, are sufficient for all practical purposes.

The whole of the foregoing, and also such work as modelling in plaster, wax, and gelatine, is carried on in the preparation room, and from it is

Fig. 4.—Jar for Collection of Organisms from Atmosphere.

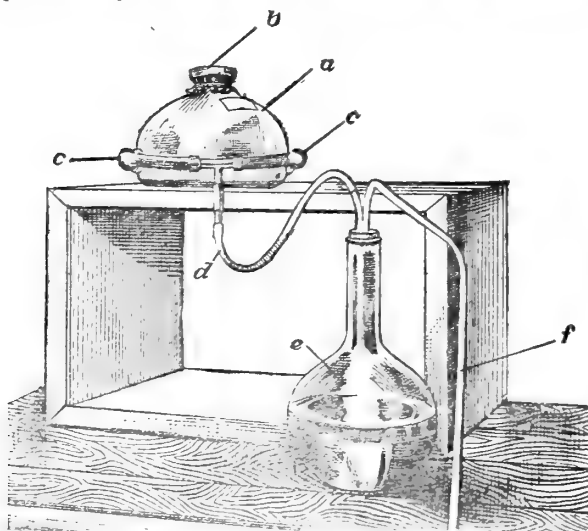

a, air jar; b, perforated rubber cap; c, elbow tubes; d, exhaust tube; e, litre flask with (f) tube leading from it.

reached the microscope room. Here the sections are placed under suitable lenses, and the results of such observation are recorded. Frequently photography, both with the ordinary camera and with the microscope and camera combined, is called into aid in this important matter. Fig. 3 illustrates the almost unique and expensive apparatus employed for photo-micrography. It was made by Messrs. Swift & Son from designs and under the superintendence of Mr. A. Pringle, of Bexley Heath; it is fitted with the oxy-hydrogen light of about 600 candle-power, and may be used to obtain enlargements up to about 4,000 diameters.

In this room is stored the apparatus not in actual use, and also some which is kept ready for emergencies.

A jar, which is of peculiar construction, and is used for the collection of organisms from the atmosphere, is worthy of notice (fig. 4). The bottom of this jar is covered with a layer of peptonised gelatine, which has been

sterilised. The air is then slowly exhausted through the orifices at *c c*, and replaced by a current which finds entrance at *b*; the organisms in this current gravitate and stick to the layer of gelatine on the bottom of the jar, and from this, when they have grown into colonies, they may be transferred to tubes for further observation, &c.<sup>1</sup>

From the foregoing description some idea of the equipment of, and of the laborious and tedious nature of the work carried on in, this department may be formed. Of course it is quite impossible in the short time that has elapsed since the laboratory was completed to furnish any results of the investigations which are at present being conducted; but, as might be expected, contagious pleuropneumonia has received a good deal of attention, and more especially a form of it wherein the lungs of the animals presented rather different appearances to those usually seen in such cases. Tuberculosis, anthrax, swine-fever, foot-rot in sheep, various morbid growths (tumours), and lungs of sheep affected with parasites have been examined.

Numerous morbid specimens have been received during the time the laboratories have been opened, and there is good reason to believe that the extent of the means of research will not be in excess of the demands which will be made upon them in the immediate future.

#### *Inquiries into Outbreaks of Disease among Farm Stock.*

On January 18 a visit was made to Hereford in reference to a cow suffering from chronic disease of the stomach and liver. The chief features of the case were general weakness, loss of appetite, progressive wasting, and suspended rumination, with other symptoms of disordered digestion. The animal died, and post-mortem examination revealed an enlarged and disorganised liver and an atrophied and much dilated state of the walls of the rumen.

At the request of a farmer residing near Southminster, an inquiry was instituted into an outbreak of anthrax in a flock of ewes. In the course of the inquiry it transpired that since 1886 several horses and pigs had died suddenly after being turned into a certain pasture on the farm, and from the description given of the symptoms and post-mortem examinations there was no doubt that the losses sustained were due to some form of blood-poisoning. In one or two instances the spleen was noticed to be considerably enlarged, and the lesions generally were such as to denote anthrax. The water supply to the suspected pastures is furnished by a brook into which, it is said, surface-drainage is received from adjacent fields, which from time to time are manured

---

<sup>1</sup> I have to thank Dr. Noel Paton and the Laboratory Committee of the Royal College of Physicians of Edinburgh for placing at my disposal the blocks from which figs. 1, 2, and 4 have been produced, and Messrs. Swift & Son for the block for fig. 3.—G. T. B.

with imperfectly-boiled flesh obtained from a neighbouring "knacker-man." The flock of ewes to which the outbreak refers was turned into these pastures for a few hours on May 1. On the 3rd, two of them died suddenly, and on the 4th three others succumbed after a brief illness. Parts of the dead sheep were given to pigs, and in a short time all that partook of them developed symptoms of anthrax. Examination of the blood of the sheep revealed the presence of anthrax organisms.

On February 1 a request was made for a visit into Surrey, where several cows presented small tumours beneath the skin of the udder, supposed to be tuberculous. General and microscopical examination of the morbid growths showed them to consist of fat, and they were reported to be quite innocent growths and in no way likely to contaminate the milk. The hereditary nature of these formations was strikingly marked in the fact that mother, daughter, and granddaughter were each and all affected.

On March 18 an inquiry was made into an outbreak of skin disease of a peculiar nature affecting a flock of sheep in Kent. The malady is reported to have prevailed in the flock for several years, resulting in the loss of four or five sheep annually. It is confined to ewes, and appears to commence shortly after the tugging season. In every case it has proved fatal. Small, ill-conditioned animals are most frequently its victims. The duration of the disease usually exceeds two or three months.

With reference to the symptoms, it is remarked that the fleece first becomes unusually light in colour, and soon the affected animals are seen to nibble the wool and to show irritation of the skin by rubbing and biting themselves. Later on the body becomes emaciated, the wool falls off in locks, until the fleece is completely shed, and death sooner or later results from exhaustion.

Examination of the skin reveals here and there small red spots scattered over the surface, and slight scurfiness. Microscopical examination of the scurf and of the skin itself was made, but no parasites were found. Post-mortem examination showed all the organs of the body to be free from organic disease. The malady is still the subject of inquiry.

A visit was made into Hampshire on April 18 respecting an outbreak of disease among sheep. At that time 100 of the flock, out of a total of 807, had died. The chief symptoms of the disease were diarrhoea and wasting, resulting in exhaustion and death. In some few instances sudden attacks of giddiness with inability to stand were the only indications of disease. The duration of the malady was from one to three weeks. In one or two instances, however, it did not exceed forty-eight hours.

Congestion and inflammatory changes in the stomach and intestines, softening of the kidneys, and a general watery state of the tissues of the body were the chief post-mortem changes. Some parasites (*Trichocephalus affinis*) were found in the large bowels, but not in large numbers. The sickness and mortality were considered to arise out of the indifferent supply of milk furnished by the ewes,



compelling the lambs to subsist almost exclusively on dry food and the tops of turnips, which they had not the power to digest.

The circumstances relating to an outbreak of anthrax on a farm in Sussex were inquired into in May last. The disease occurred in a herd of beasts of which seven or eight succumbed or were destroyed. The herd was divided into several lots, and with one exception the disease was confined to animals receiving furze as a part of their food. Large quantities of foreign grain were being used for feeding purposes, but whether this or the Indian bones with which the pastures had been freely dressed was the source of infection could not be satisfactorily determined. It was believed, however, that the sharp spines of the furze, by wounding the mouth, had opened a channel for the entrance of the virus into the system. Acting upon this view of the causation of the disease, measures of prevention were prescribed, and mortality ceased.

On June 17 a visit was made into Wiltshire, where a large mortality was reported in a flock of lambs. The disease had existed for some weeks, and had proved very destructive. Profuse diarrhoea, rapid wasting, ending in exhaustion and death, were the chief symptoms of the affection. Post-mortem examination was made in several instances, and considerable numbers of thread-worms (*Trichocephalus affinis*) were found in the large bowels of all the cases inspected. A course of treatment, general and medical, was prescribed, with the result that the mortality ceased, and the health and condition of the flock rapidly improved.

An inquiry into an outbreak of influenza fever in Lincolnshire was made in July last. The disease appeared in a stud of horses belonging to a farmer, and although it had caused serious losses, it had so far abated at the time of the inquiry as to require no special treatment.

On August 20 advice was sought respecting a sudden outbreak of disease in a herd of cattle belonging to a farmer in Berkshire. At the time of the occurrence the animals were pastured in fields adjoining the house and farmstead, and immediately preceding it a large pond in the garden had been run off into the pasture. The water carried with it a considerable amount of putrefying organic matter, and it was believed the cattle had partaken freely of this, and in consequence had become the subjects of septicæmia or blood-poisoning, which both the symptoms and post-mortem appearances denoted. Eleven animals were suddenly attacked, of which number one died and the remaining ten had to be destroyed. Dulness, stupor, muscular tremors, great prostration, and an unsteadiness in the gait were the leading symptoms. Post-mortem examination showed intense general congestion of the principal organs of the body, and blood extravasations into the tissues of the stomach, kidneys, lungs, and heart. Search was made for other possible causes of the outbreak, but none were found.

In October last inquiry was made into an outbreak of parasitic bronchitis in a herd of Jersey heifers belonging to a farmer in Worcestershire. The disease was almost exclusively confined to

animals recently imported, of which nine were attacked out of a lot of eighteen, and four died. The great percentage of deaths resulting from the disorder was not altogether due to the direct influence of the parasites, but was materially influenced by exertion and exposure while travelling to and from agricultural shows. A frequent husky cough with free expectoration, hurried breathing, diarrhœa, increasing prostration and weakness, were the leading symptoms. Post-mortem examination revealed large numbers of thread-worms (*Strongylus micrurus*) in the bronchial tubes, and considerable consolidation and disorganisation of the lungs resulting from broncho-pneumonia. With regard to treatment, it was recommended that the sick beasts be placed in a dry well-ventilated shed, and be kept perfectly quiet. The body was ordered to be clothed, and a plentiful supply of good nutritious food allowed. Diffusible stimulants and tonics were also prescribed according to the requirements of the case.

On November 10 an inquiry was made into an outbreak of cowpox in a herd of milch cows in Wiltshire, with special reference to the fitness of the milk for human consumption. The herd comprised about sixty animals, the greater number of which were suffering from the disorder. The disease had existed for several weeks when the inspection was made, and, commencing simultaneously in one or two animals, it gradually extended to others, and ultimately through nearly the whole herd. Of several men engaged in milking three were inoculated in the hands, which gave rise to an eruption similar to that on the cows' teats. The eruption as it appeared on the latter commenced in one or more thickened and slightly raised spots on the teats. In a short time these were followed by small vesicles or blebs, which on being broken by the hands in milking were soon converted into angry-looking ulcers. Further manipulation of the teats resulted in considerable swelling, and in several instances the inflammatory action extended to the udder, and this, together with imperfect milking, led on to garget and destruction of one or more of the quarters. Notwithstanding the state of the teats, and the infectious character of the disorder, all the animals continued in good general health throughout the attack. It is interesting to note that although the milk from these animals was being drunk for three weeks by large numbers of persons, no ill effects were reported from its use. It was nevertheless considered unfit for human consumption, and ceased to be used for that purpose.

*Cases of Disease in Cattle, Sheep, and Swine admitted for  
Treatment during the year 1890.*

Amongst a variety of interesting and instructive cases of disease received in the College Infirmary from members of the Society and also from district veterinary surgeons in the course of the past year were the following :—

(a) Sheep suffering from aphthous disease affecting the lips and

sometimes the legs, particularly on sandy or gritty soils, during wet and cold weather. This malady did not prove to be contagious, as healthy sheep penned with the diseased ones did not suffer.

(b) Contagious mammitis (garget) in ewes: a disease which has proved very fatal in wet weather in several districts.

(c) Cases of parasitic lung disease in lambs.

(d) Cases of pleuro-pneumonia in cattle, for experimental treatment by sulphurous acid gas, which was not proved to possess the curative properties ascribed to it.

(e) Cases of foot-rot in sheep were admitted at different times during the year, and experiments were tried to test the alleged contagious character of the disease, but without result. Further experiments will be made as opportunities occur.

(f) Several lambs were admitted suffering from diarrhœa, resulting from the invasion of tape-worms; but these parasites were not so common among lambs as they were during the previous year.

It is not possible in the space which is available for this Report to refer to the investigations which have been carried on for more than a year in reference to the life-history of the lung-worm. But a separate Report is being prepared, and will shortly be ready for publication.

G. T. BROWN, *Principal of the College.*

January, 1891.

---

## FURTHER REPORT OF THE EDUCATION COMMITTEE ON TECHNICAL EDUCATION IN AGRICULTURE.

[For previous Report, see Vol. I., Third Series (1890), page 851.]

SINCE the meeting of the Council in November last, when the subject of agricultural education was discussed, the question has been prominently brought forward at the meetings of County Councils, and of agricultural clubs and societies in most parts of England. Several letters asking for advice or suggestions on the subject of education have been received by the Secretary of the Society and by individual Members of the Committee. Almost every County Council in England proposes to devote a portion of its funds to the teaching of agriculture. It is, therefore, very desirable that these funds should be applied systematically, and not wasted over temporary or ephemeral projects.

2. The first difficulty in administering the funds, which are at present at the disposal of the County Councils, arises from the restriction imposed, "that these funds must be applied in institutions existing in the administrative county in which the funds are raised or have been granted." The Government have, however, promised to introduce a Bill to remedy this defect; and our sugges-

tions are based on the supposition that these funds may be used for assisting institutions in contiguous counties when it is evident that the inhabitants of the county so contributing would be benefited thereby.

3. We must not imagine that our agricultural population is so destitute of means of agricultural information as some people would declare. For years earnest and cultivated men, like Sir John Lawes, Sir Harry Thompson, Mr. Pusey, Mr. Chalmers Morton, Mr. Wren Hoskyns, and many more whom we could mention, gave to the public the results of their research in the pages of the Journals of the Royal Agricultural and the Bath and West of England Societies, and in the "Agricultural Gazette." Since those earlier days others have continued in the agricultural press of the present day to spread their theories and extend their teaching; and every one who has noticed farm progress for the last fifty years, both in prosperous and unfortunate times, has seen the result of this teaching. We might also mention the good work done at Cirencester, Downton, and elsewhere, and the encouragement given in this direction by the Science and Art Department and by our own Society.

4. There is now, however, a demand for something beyond this. We are asked to provide competent teachers who may instruct classes in colleges or schools, or who may take their teaching to the country villages and towns, and so bring it home to the people interested.

5. Many institutions for higher education have of late years been established, and these have already in existence the means of teaching physiology, chemistry, botany, mechanics, and other branches of science which are cognate to agriculture. It would not, we think, be difficult to find such convenient centres in most parts of England. The College of Science at Newcastle, affiliated to the University of Durham, would supply a centre for the northern counties; the Yorkshire College at Leeds for Yorkshire; the Owens College at Manchester for Lancashire and Cheshire; the University College of North Wales at Bangor for North Wales and the border counties; Nottingham for one portion of the Midlands, Birmingham for another; Cambridge for the Eastern and Oxford for the Home Counties. No doubt we have omitted some institutions; but we have sufficiently indicated that there are already in existence centres of education which might serve for groups of counties, at which could be obtained the adequate instruction of teachers, and also at which students might attend without much difficulty.

6. Groups of County Councils might agree to support the agricultural or other technical instruction at these centres. A common course of teaching might be agreed upon between the authorities of these institutions, a common standard for degrees, diplomas, and scholarships, and possibly a common Board of Examiners. To all these objects the County Councils affected might contribute; and scholarships might be given by local authorities, and by the Royal and other Agricultural Societies. It might then be possible to relinquish the Senior Examinations of the Royal

Agricultural Society, and to give instead a certain number of medals or other honours for distinguished students. New scholarships of more value than those now existing might be given for older students, without relinquishing those which we furnish for boys, and which are of considerable advantage.

7. At these centres of education the analysis and examination of manures and feeding stuffs might be carried out; research in physiology and other studies encouraged; and a class of students and teachers educated who would be available for agricultural sides in county or other middle schools. From the same source would come peripatetic lecturers, and instructors for village classes and continuation schools. We should look forward at most centres to the establishment of dairy schools, both fixed and peripatetic, and to the provision of such lectures on rural life as might equally interest the farmers' and the labourers' children.

8. It is not our province to enter into detail as to how such schemes could be carried out, but rather to suggest a general view of the subject, and to indicate that the Royal Agricultural Society and the County Councils may do more good in assisting existing institutions, and in aiding the establishment of new institutions of a similar character, than by attempting themselves to establish teaching institutions of their own.

MORETON, *Chairman.*

February 3, 1891.

[For the discussion in Council on the adoption of this Report, see page xxxiv of the Appendix.]

---

## QUARTERLY REPORT OF THE CHEMICAL COMMITTEE,

MARCH 1891.

1. Mr. J. Bayley, of Willaston Hall, Nantwich, sent on May 25, 1890, a sample of manure sold as "Blood and Bone," price 7*l.* 10*s.* per ton. The following analysis and report was returned on June 2:

Moisture . . . . .	21.30	
<sup>1</sup> Organic matter and water of combination . . . . .	22.78	
Monobasic phosphate of lime . . . . .	4.85	
Equal to tribasic phosphate of lime (bone phos- plate) rendered soluble by acid	(7.60)	}
Insoluble phosphates . . . . .	11.30	
Sulphate of lime, alkaline salts, &c. . . . .	29.76	}
Insoluble siliceous matter . . . . .	10.01	
<sup>1</sup> Containing nitrogen . . . . .		1.77
equal to ammonia . . . . .		2.15

The manure contains some bone, but the price charged for it is altogether absurd.

Repeated applications for further particulars of the transaction failed to elicit any reply from Mr. Bayley.

2. Mr. E. F. Maunder, of Crichel, Wimborne, sent on November 20, 1890, a sample of linseed-cake which was offered to him at 8*l.* per ton. The following analysis and report was returned on November 27 :

Moisture . . . . .	13.50	} 100.00
Oil . . . . .	9.01	
<sup>1</sup> Albuminous compounds (flesh-forming matters) . . . . .	26.50	
Mucilage, sugar, and digestible fibre . . . . .	31.34	
Woody fibre (cellulose) . . . . .	11.10	
<sup>2</sup> Mineral matter (ash) . . . . .	8.55	
<sup>1</sup> Containing nitrogen . . . . .	4.24	
<sup>2</sup> Including sand . . . . .	3.55	

The cake is a very impure one, containing over 3½ per cent. of sand and a considerable admixture of foreign seed, and some earth-nut husk.

In reply to inquiries Mr. Maunder wrote as follows :

December 8, 1890.

DEAR SIR.—*Re* linseed cake 1437. I have seen the party from whom I obtained the cake of which I sent you a sample. The cake was sent me by an error, as he had two lots come in, and his man loaded my wagon from the wrong lot: this is sold as an impure cake at 7*l.* 5*s.* per ton, and is manufactured in Hull.—I am, yours truly,

EDWIN F. MAUNDER.

Dr. Voelcker.

An allowance was subsequently made to the purchaser.

3. Mr. Philip Ascroft, of Rufford, near Ormskirk, sent on December 3, 1890, a sample of manure, 25 tons of which he had bought as "Blood and Bone Manure," price 3*l.* per ton on rail.

The following analysis and report was returned on December 2 :

Moisture . . . . .	15.70	} 100.00
<sup>1</sup> Organic matter . . . . .	38.50	
Phosphate of lime . . . . .	3.21	
Oxide of iron, alumina, &c. . . . .	29.14	
Sand . . . . .	13.45	
<sup>1</sup> Containing nitrogen . . . . .	2.75	
equal to ammonia . . . . .	3.34	

The manure called "Blood and Bone Manure," which you say you bought as "pure," appears to be mere refuse bone and hair material mixed with some blood. The bone is chiefly conspicuous by its absence. It is of course absurd to describe such a material as "pure" blood and bone manure; it is neither pure blood nor pure bone. As a rule, manures of this description are sold at prices very much in advance of their actual value.

Mr. Ascroft wrote, on December 15, to say that, as he had merely purchased according to a sample handed to him at the time, he had no claim against the vendor.

4. Mr. J. C. Beall, of Bletsoe Park, Bedford, sent on December 10, 1890, a sample of soot which he had bought as genuine and free from any admixture—price 45s. per ton carriage paid. The delivery appearing unusually heavy and in wet condition, Mr. Beall sent a sample for analysis. The following analysis and report was returned on December 13 :

Moisture . . . . .	16.70	}	100.00
<sup>1</sup> Organic matter and ammonia salts . . . . .	30.72		
Oxide of iron, alumina . . . . .	26.46		
Carbonate of lime, &c. . . . .	9.65		
Insoluble siliceous matter . . . . .	16.47		
<sup>1</sup> Containing nitrogen . . . . .	1.18		
equal to ammonia . . . . .	1.43		

The sample consists largely of cinders, flue scrapings, &c., and contains but little valuable soot. It is not worth anything like the price charged.

Subsequently Mr. Beall wrote that, as he had been given a very considerable reduction, he was not willing to mention the vendor's name. The amount of this reduction was 12s. 6d. per ton.

5. Mr. J. Pratt, of Lickhill Farm, Stourport, sent on January 29, 1891, a sample of a 2-ton lot of cake, which he said was sold to him as "pure," and to contain 11 to 12 per cent. of oil, the price being 8*l.* 7*s.* 6*d.* per ton, carriage paid. The following analysis and report was returned on February 4 :

Moisture . . . . .	14.25	}	100.00
Oil . . . . .	11.97		
<sup>1</sup> Albuminous compounds (flesh-forming matters) . . . . .	21.06		
Mucilage, sugar, and digestible fibre . . . . .	31.55		
Woody fibre (cellulose) . . . . .	12.57		
<sup>2</sup> Mineral matter (ash) . . . . .	8.60		
<sup>1</sup> Containing nitrogen . . . . .	3.37		
<sup>2</sup> Including sand . . . . .	4.01		

The cake, although possessing oil above the guarantee, does not contain this in the form of pure linseed-oil, for there are hemp, rape, earth-nut, spurry, and other seeds in quantity mixed with the linseed. As a consequence, the percentage of nitrogen is very low, and the fibre excessive, also there is 4 per cent. of sand present, and the cake is altogether a very impure one.

The cake was one of Hull manufacture, and was purchased of an agent in Kidderminster market. Mr. Pratt added that he would be careful how he purchased in the future, for though the agent informed him that the cake was sold as *oil-cake*, he was under the impression at the time that he was buying *linseed-cake*.

A reduction of 2*l.* 10*s.* was subsequently made.

6. Mr. R. Neville Grenville, of Butleigh Court, Glastonbury, sent on February 3, 1891, a sample of linseed-cake which had been supplied in December to a tenant of his, by Messrs. Croad & Brown,

**Bridgwater Oil Mills.** Half a ton had been purchased at 8*l.* 5*s.* per ton. The following analysis and report was returned on February 6 :

Moisture . . . . .	12·50	} 100·00
Oil . . . . .	10·76	
<sup>1</sup> Albuminous compounds (flesh-forming matters) . . . . .	26·50	
Mucilage, sugar, and digestible fibre . . . . .	32·04	
Woody fibre (cellulose) . . . . .	8·30	
<sup>2</sup> Mineral matter (ash) . . . . .	9·90	
<sup>1</sup> Containing nitrogen . . . . .	4·08	
<sup>2</sup> Including sand . . . . .	4·00	

In addition to the 4 per cent. of sand, the cake contains admixture of rape and starch-yielding seeds. It is an impure cake.

The vendor, when spoken to as to the inferiority of the cake, stated that, being out of cake at the time, he bought this lot, and was selling it for 5*s.* per ton less than he gave for it.

7. Mr. T. Holtby, of Cowlam, York, sent on February 13, 1891 a sample of manure which he had purchased at 80*s.* per ton. The following analysis and report was returned on February 18, 1891 :

Moisture . . . . .	18·25	} 100·00
<sup>1</sup> Organic matter . . . . .	16·05	
Sulphate of lime . . . . .	45·54	
Oxide of iron, &c. . . . .	2·44	
<sup>2</sup> Phosphoric acid . . . . .	1·77	
Sand . . . . .	15·95	
<sup>1</sup> Containing nitrogen . . . . .	·44	
equal to ammonia . . . . .	·53	
<sup>2</sup> Equal to phosphate of lime . . . . .	3·86	

This is a manure of but little value, and the price asked is extravagant. It is half gypsum with about 4 per cent. of phosphate of lime, and contains little more than this of any value.

Mr. Holtby said he had not asked for any guarantee, and was unwilling to give vendor's name.

The Committee have reason to know that a considerable amount of cake is being sold as "*oil-cake*" which is not made from pure linseed, but contains a large admixture of other seeds, some of which may be injurious to stock; they would, therefore, warn farmers against purchasing "*oil-cake*" under the impression that they are getting "*pure linseed-cake*," and they again wish to impress upon buyers the desirability of insisting that the invoice shall describe the purchase as "*Pure Linseed-Cake*."

EMLYN, *Chairman.*

March 3, 1891.



## REPORT OF THE CONSULTING AND ACTING CONSULTING CHEMISTS FOR 1889 AND 1890.

NOTWITHSTANDING the large accession to the number of Members of the Society which took place in 1889, there were fewer samples sent to the Laboratory for examination than in the year previous. In 1890 there was, however, a small increase in the number of samples sent by Members, as will be seen from the following comparative table :—

*List of Analyses made for Members of the Society.*

	1889	1890
Linseed-cakes . . . . .	359	454
Uncorticated cotton-cakes . . . . .	73	95
Decorticated cotton-cakes . . . . .	85	85
Compound feeding-cakes and meals . . . . .	56	35
Rice-meals . . . . .	9	6
Cereals . . . . .	18	15
Dried grains . . . . .	—	8
Silage and hay . . . . .	1	2
Butter, milk, and cream . . . . .	6	8
Waters . . . . .	117	143
Superphosphates . . . . .		
Dissolved bones and compound artificial manures . . . . .	301	276
Bones and bone-meals . . . . .	107	76
Peruvian guano . . . . .	20	18
Fish guano . . . . .	28	21
Shoddy . . . . .	20	29
Basic slag . . . . .	15	22
Sulphate of ammonia . . . . .	23	7
Nitrate of soda . . . . .	54	65
Potash salts . . . . .	20	11
Refuse materials . . . . .	54	49
Soils . . . . .	41	12
Miscellaneous . . . . .	24	10
	1,436	1,447
Analyses in connection with the Annual Country Meeting . . . . .	80	20
Analyses in connection with the Woburn experiments and those of Local Agricultural Societies . . . . .	123	79
Total . . . . .	1,639	1,546

*Linseed-cakes.*—Feeding materials, and especially linseed-cakes, have, as usual, formed a large proportion of the samples sent for examination, and, indeed, it is well that this should be the case. The Chemical Committee's Quarterly Reports show markedly the attempts of certain vendors to avoid committing themselves to a clear

guarantee of the purity of the linseed-cakes they offer for sale, and also the prevalent disregard by Members of the advice which the Society gives them, only to buy cake which is "guaranteed pure and delivered in good condition." In the spring of 1890, the Council issued to the Members of the Society a form of contract embodying these conditions, and it is gratifying to know that in the majority of cases where this guarantee has been insisted upon, a pure cake has been supplied.

The plea constantly put forward by vendors is, that it is impossible to guarantee a cake to be "pure," and this is given as an excuse for a guarantee in such terms as "made from linseed imported on a basis of 96 per cent. purity." Such a guarantee is, however, useless; that linseed is bought on a 96 per cent. basis unfortunately does not mean that it contains 96 per cent. of linseed. When a cargo of linseed is imported into this country, samples are taken and analysed by the Linseed Association, under a contract according to which, in the case of Calcutta seed, 4 per cent. of admixture is allowed. The amount of dirt and foreign seed is determined in a sample drawn from the cargo, and, should it exceed the allowed 4 per cent., a reduction is made in the price. Non-oleaginous seeds and dirt are considered valueless, but oleaginous seeds, other than linseed, are reckoned as being half the value of linseed. A cargo of linseed may thus be bought on the 96 per cent. basis, and yet not contain anything like 96 per cent. of linseed. In the quarterly report of the Chemical Committee for March 1890, a case is mentioned in which the manufacturers of a linseed-cake, which was reported on as containing an excessive quantity of sand, stated that they found that some of the seed which they had bought on the 96 per cent. basis contained no less than 28 per cent. of dirt.

A guarantee commonly insisted on by cake-makers is that of "95 per cent. pure." This is open to the objection that, after the seed has been crushed and made into cake, it is impossible to ascertain definitely whether there is 95 per cent. of linseed in it or not. Before the seed is crushed it is perfectly easy to determine this; but, when one is no longer able to pick out the individual seeds, nothing more than an approximation to the real percentage can be arrived at. Again, in such a guarantee, no notice is taken of what the 5 per cent. of impurity consists; it might be, for instance, some poisonous seed, such as castor-oil bean or mustard. Such a guarantee, further, opens the door to the wilful admixture with a pure seed of adulterants, the exact amount of which cannot be precisely determined. To the cake-makers who endeavour by careful screening to produce a really pure cake, the recognition of such a guarantee as the above is an injustice.

That linseed-cake, in order to be considered pure, should be absolutely free from every particle that is not linseed is of course impracticable. Linseed naturally contains impurities, and it is hardly possible to remove every trace of these. By careful screening, however, the purification of the seed can be carried to an extent which leaves it practically pure: and this is, in fact, actually done

by those makers who are willing to go to the necessary trouble and expense.

The existence of so many inferior cakes in the market is the fault of those farmers who look more to their actual money outlay than to seeing that they get their money's worth. So long as they are content to buy, as linseed-cake, cake which contains all the impurities which may naturally be in the seed, or which have been added to it, so long will the supply meet the demand. Were they one and all to insist on having pure cakes only, there would soon be no market for the many bad cakes sold. The term "oil-cake" is a misleading one, and may now almost be taken as synonymous with *impure* linseed cake. Such "oil-cakes" are media for getting rid of the dirt and weed seeds which are removed from linseed and other seeds, and, although they are sold at prices much below that of pure linseed cake, and are described as being "good value for the money," they are often dear at any price. Numerous cases of injury to stock have arisen through feeding on oil-cakes which have contained seeds of a deleterious nature.

That farmers are very careless in the manner in which they purchase their feeding-stuffs and manures is an indisputable fact. The common practice of taking, in return for their farm produce, cake and manures from dealers without any guarantee whatever, is a fertile source of the farmer being defrauded. The figures of an analysis are in themselves alone no sufficient guarantee; for a linseed-cake may be impure and yet show a very good analysis.

The necessity of having a guarantee such as is put out in the Society's form of contract is clearly shown by the following instance which occurred recently. A Member of the Society had purchased a quantity of linseed-cake on the strength of an analysis which indicated that the cake contained nearly 15 per cent. of oil. The cake was duly delivered in two lots, but when the cattle were tried on the second lot it was noticed that they did not like it, or do as well as before. Samples were therefore taken from each delivery and sent for analysis.

The sample representing the first delivery was found to contain 11.60, and that of the second delivery 12.27 per cent. of oil, instead of the 15 per cent. stated in the analysis on which the purchase was made. Moreover, the second delivery of cake was in a mouldy and unsound condition, and the cake had evidently been made from damaged seed not fit for feeding.

American linseed-cakes, the purity of which has been favourably spoken of in previous reports, were, at least during 1889, not nearly as good as before. Since then, however, an improvement has been shown, but the cakes are generally excessively hard and low in oil.

In reference to the value of oil in linseed-cake as a feeding constituent, an experiment carried out by Mr. F. I. Cooke, of Fritcham, King's Lynn, on behalf of the Norfolk Chamber of Agriculture, is recorded in Part II. of Vol. XXV. (1889) of the Journal, and is well worthy of attention.

A fresh adulterant for linseed and other cakes has to be added

to the already long list which vexes both farmer and analytical chemist. This is the use of the refuse from glucose manufactories. Attention was drawn to it by the receipt from an anonymous source of a memorandum in the following terms: "We send you a small sample of twenty tons of the saccharine meal just fresh made. It is the palest and sweetest we have seen. The price is 37s. 6d. per ton, free delivered to steamer here, net cash, bags 2s. each. We have had no complaints from the several seed-crushers who use it regularly, of either their oil or cake, in fact several have told us voluntarily they have not had a single complaint from their customers. We are told its composition is rice, sago, and tapioca."

Subsequent to this, the presence of this material was detected in two linseed-cakes, a close examination of which was induced by the occurrence of an abnormally high percentage of mineral matter (ash), viz. between 10 and 11 per cent., instead of about 6 per cent., as is usual in linseed-cakes. This ash on analysis was found to consist largely of sulphate of lime.

*Cotton-cakes.*—In the last report attention was drawn to a number of samples of undecorticated cotton-cake which were found to be stale or mouldy, and to the danger attending their use. Considerable improvement in this respect has since been shown, but during the past season some cases of adulteration of cotton-cake with worthless materials have been referred to in the Quarterly Reports of the Committee. There are cases, also, of cotton-cake made from seed not properly freed from the cotton-wool. The danger of using such cakes is very great, inasmuch as the cotton is apt to collect in lumps and cause irritation and subsequent inflammation of the coats of the stomach. Undecorticated cotton-cake, although having—owing to its somewhat astringent properties—a special adaptability under certain circumstances, cannot compare either in feeding or manurial value with good decorticated cotton-cake. Experiments carried out at Woburn show the decided superiority of the latter in both respects. The great difficulty, however, is to obtain decorticated cotton-cake free from hard lumps, and in anything like a moderately soft condition.

As regards meals, a word of caution is necessary. A case was recently brought to notice in which several animals had been poisoned by the use of a meal made from musty decorticated cotton-cake. One or two cases have occurred in which decorticated cotton-cake has been found to be mixed with rice and rice-meal, ostensibly for the purpose of rendering it softer. This is well enough so long as the cake is sold under the clear understanding that it is a *mixed* cake, and if it be priced accordingly. When, however, it is merely described as "decorticated cotton-cake of a soft kind," and the price has been the full one of pure decorticated cotton-cake, notwithstanding the admixture of the cheaper rice meal, the sale under such description should not be permitted.

*Hemp-cake.*—A sample of this gave on analysis:—

Moisture . . . . .	13.43
Oil . . . . .	9.10
<sup>1</sup> Albuminous compounds . . . . .	30.50
Digestible fibre, mucilage, &c. . . . .	15.36
Woody fibre . . . . .	23.53
<sup>2</sup> Mineral matter (ash) . . . . .	8.08
	100.00

<sup>1</sup> Containing nitrogen . . . . . 4.88

<sup>2</sup> Including sand . . . . . 2.09

The cake in some respects is richer than ordinary cotton-cake, though having rather more woody fibre. The extracted oil had a somewhat acid character, and hemp-cake may probably not be so good a food as cotton-cake, though, when cattle have become used to it, it may do as a substitute in the case of fattening animals.

The price, 5*l.* 10*s.* per ton at Hull, offers, however, no special inducement for its use in preference to cotton-cake.

*Rice-meal.*—A Member of the Society sent a sample of rice-meal for examination, stating that neither horses, cattle, sheep, nor pigs would eat it, although they had all been previously feeding on rice-meal. The analysis it gave was:—

Moisture . . . . .	10.58
Oil . . . . .	8.73
<sup>1</sup> Albuminous compounds . . . . .	10.75
Starch, digestible fibre, &c. . . . .	50.23
Woody fibre . . . . .	11.33
<sup>2</sup> Mineral matter (ash) . . . . .	8.38
	100.00

<sup>1</sup> Containing nitrogen . . . . . 1.72

<sup>2</sup> Including silica . . . . . 4.04

This meal was not of good quality, and, as shown by the excessive amount of woody fibre, contained a good deal of the husk left with it. As the animals possibly were previously feeding on a good quality meal, the fact of this excess of husk may not improbably have kept them from taking the new lot readily.

*Manures.*—Superphosphate, which for some time past had been sold at extremely low prices, has more recently experienced a decided rise in price. This has been caused mainly by the increased cost of labour and freight, also by the scarcity of phosphates suitable for the manufacture of good superphosphate. To meet the increased cost, superphosphates of very inferior quality, and made from low-grade phosphates, have been in several instances sold to those farmers who do not trouble to buy with a definite guarantee of quality.

The last number of the Society's Journal contains records of cases in which superphosphate has been sold at prices of 3*l.* 5*s.* and 3*l.* 10*s.* per ton, and yet has only contained from 18 to 21 per cent. of soluble phosphate. This clearly shows the necessity for farmers buying with a definite guarantee. In this connection it is satisfactory to note that the Chemical Manure Manufacturers' Associa-

tion—an association representing the leading manure manufacturers of the country—at their general meeting last year passed the following resolution :—

That this meeting is of opinion it is desirable, in the interests of the trade, that, for the future, the percentage of soluble phosphate guaranteed shall be branded on each bag sold for the home trade in a conspicuous place.

A farmer, therefore, has now only himself to blame, if he does not satisfy himself as to the quality of the superphosphate he buys.

*Dissolved Bones.*—In the published Quarterly Reports reference has been made to some cases of manures sold as “pure dissolved bones,” which on examination have proved to contain either an admixture of material other than bone, or to be made from bones which had been deprived of the greater part of their nitrogenous matter by the process of steaming them. Under the provisions of the Merchandise Marks Act it has been laid down by the highest authorities that, for a manure to be properly described as “pure dissolved bones,” it must be made from raw bones and acid only, without any admixture whatever.

*Nitrate of Soda and other Nitrogenous Manures.*—It is worthy of note that, during the two years, the numerous samples of nitrate of soda sent for analysis have all been found to be genuine ; sulphate of ammonia, with few exceptions, has also been of good quality. Samples of shoddy, wool-refuse, &c. frequently contain a large quantity of dirt, and in many instances weed-seeds occur to a large extent. These, when their vitality has not been destroyed, are a very fruitful source of spreading the growth of weeds upon land to which such shoddy is applied. Cotton-waste, a substance manurially of no value, was in one instance sold as wool-manure, and was reported upon accordingly.

*Refuse and Miscellaneous Materials used for Manure.*—The most frequent source of imposition which the farmer experiences is undoubtedly in the sale to him of materials with no proper guarantee of quality, or else under misleading descriptions worded in such a way as to make him believe that he is buying at a very low price a manure which is a very valuable one. A frequent practice with respect to many manures to which high-sounding descriptions are given, is to lay special stress on the words “guaranteed analysis,” and to publish in a conspicuous part of the circular an analysis which on a close examination is found to be not really the one guaranteed, and which does not represent the composition of the material actually sold.

Cases of the above nature have been repeatedly published in the Quarterly Reports of the Chemical Committee, but unfortunately the attraction of a low price is a strong incentive to a farmer to buy what is represented to him as being a manure worth two or three times the price asked. For example, a farmer bought 14 tons of a manure stated to be genuine Peruvian guano at 2*l.* 12*s.* 6*d.* a ton. The following was the analysis :—

Moisture . . . . .	6.76
<sup>1</sup> Organic matter . . . . .	9.89
Phosphoric acid . . . . .	23.05
Lime . . . . .	23.51
Oxide of iron, alumina, &c. . . . .	29.92
Insoluble silicious matter . . . . .	6.87
	100.00
<sup>1</sup> Containing nitrogen . . . . .	0.20
equal to ammonia . . . . .	0.24

This material did not partake at all of the nature of Peruvian guano. It contained practically no ammonia, and was simply a phosphatic material containing a large amount of iron and alumina. In another instance, a purchaser of a so-called "turnip manure," being doubtful of its quality, sent a sample for examination. The analysis showed:—

Moisture . . . . .	23.60
<sup>1</sup> Organic matter . . . . .	10.02
Sulphate of lime . . . . .	30.16
Carbonate of lime . . . . .	1.87
Oxide of iron, alumina, &c. . . . .	5.85
Phosphate of lime . . . . .	0.70
Insoluble silicious matter . . . . .	27.80
	100.00
<sup>1</sup> Containing nitrogen . . . . .	0.48
equal to ammonia . . . . .	0.58

This material was nothing but waste impure sulphate of lime, possessing very little value indeed.

*Waters.*—During 1890 an exceptionally large number of samples of water were sent for analysis. This no doubt was mainly due to the scarcity experienced in the water-supply. Many new wells were sunk, and disused wells were once more called into requisition. The water of these often proved to be greatly contaminated and altogether unfit for a drinking supply. Several waters, otherwise pure, contained, moreover, appreciable quantities of lead in solution. This in some cases amounted to as much as three-quarters of a grain per gallon. These were, as a rule, soft waters, but not in every instance.

It may, in conclusion, be mentioned that, in addition to the list of analyses given at the commencement of this Report, a very large number (upwards of 800) of partial analyses of the soils of the Woburn experimental fields were made during the year 1890.

J. AUGUSTUS VOELCKER.  
E. W. VOELCKER.

## REPORT OF CONSULTING ENTOMOLOGIST.

IMMEDIATELY on the breaking up of the long frost of December and January, inquiries regarding insect pests (then found in good health and uninjured by weather influences) recommenced as usual.

At the beginning of February I had observations (with specimens accompanying) of Cockchafers' grubs being turned up at a locality in Aberdeenshire at the rate of some hundreds to the acre. On January 29, inquiries were sent me regarding what proved to be the (sometimes) very destructive caterpillars of the Common Swift Moth, *Hepialus lupulinus*, being found in bean stubble, about six inches below the surface, with the frost still in the ground for several inches below them. These were from near Hayward's Heath, in Sussex. Also at Seaford Grange, near Pershore, about 9 or 10 o'clock in the evening of January 29, moths of various kinds were found to be about in plenty. Amongst them were females both of the Winter and of the Mottled Umber Moths.

These points are of serviceable interest to note just now, as giving proof from field observation (of what is well known scientifically) that cold—at least, such cold as is ordinarily met with in this country—cannot be depended on to destroy insect life so long as the insects are in their naturally-formed or chosen shelters. So far as effect of mere cold goes, I have found in my own experiments that beetle and fly larvæ, which had been frozen torpid, showed, except in a solitary instance, no apparent damage on being thawed, neither did butterfly chrysalids after being frozen stiff; nor did I find any damage occurring to caterpillars, whether of moths or of Ichneumon parasites, nor to Thrips, nor to the Apple-bark Acari, nor to the Phytopti, which I had opportunity of examining, exposed to similar temperatures as the above, in their natural circumstances.

If, however, their natural shelters are broken up and the creatures are exposed to alternate wet and cold, their numbers may be most serviceably diminished.

The Small or Common Swift Moth caterpillars are not often inquired about, but where they do occur they have a power of doing very great mischief. They feed at the roots of a good many kinds of garden and field crops, including grass; my own acquaintance with them has been in winter and spring, at the roots of winter beans or of bean stubble when ploughed up. These caterpillars are somewhat over an inch long, cylindrical, yellowish or whitish, with brown horny head, and the next segment horny above but pale. The other segments are usually (but not always) marked on the back with four black dots, each producing a bristle, and with a line of dots and bristles running along each side. Their colour distinguishes them from the Common Surface Moth caterpillars, and they may be known



from beetle or fly grubs by being sixteen-footed. They are to be found at work at this time of the year a little below the surface of the ground, and presently change to chrysalids in cells in the earth, from which the smallish, clay-coloured and white-marked moths come out in May.

Where the ground has no growing crop on it, the best way to prevent recurrence of the attack is to plough or skim, so as to turn the caterpillars out on the surface, or thoroughly loosen the soil round them; and, even later on, amongst growing crops, cultivating as deeply as could be managed would do some good by throwing the caterpillars out to the weather and birds.

We had a very good instance of this just lately in the case of the Cockchafer grubs found near Skene, in Aberdeenshire. These great grubs, of which specimens were sent me on February 2, were found, in ploughing up lea to a uniform depth of  $5\frac{1}{2}$  inches, to the amount of a few hundreds per acre. Those which were thrown out were found not to have sufficient vitality to rebury themselves; and as the plough was commonly followed by large birds, specified as

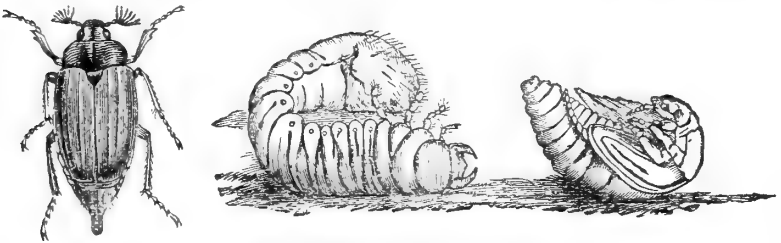

Common Cockchafer, with larva and pupa.

crows, starlings, &c. which cleared the grubs thoroughly, the work was done very satisfactorily.

The grubs sent me appeared to be full-grown, at which stage they are usually considered to go down much deeper than six inches; but on inquiry I received information that they had not been further down, for they were all found at the bottom of their burrows. There was, however, so much "foggage"—that is to say, old grass remaining on the grass-land which was being broken up—that this acted in some degree as a protection from the frost.

The above notes appear to be worth special attention as being practical observations of the serviceableness of turning out caterpillars in the winter.

With regard to the Winter Moths, and some others of the Orchard Moths, we have also trustworthy observations of even the unusually long-continued cold of the past December and January not having availed either to prevent development of the moths from their chrysalids, or to destroy the vitality of the eggs.

On the evening of January 29 (about 9 or 10 o'clock), moths were found in plenty at Seaford Grange, near Pershore, and amongst these the wingless females of the Winter Moth (*Cheimatobia bru-*

*mata*) and of the Mottled Umber Moth (*Hybernia defoliaria*) were taken on the trunks of apples, and plums, and a large number of the winged males of the Mottled Umber Moth, living and freshly caught, were found sticking in the grease-bands on the apple-trees. Other kinds, too, were identified as being present. I have also notes from a locality in Herefordshire, where caterpillar-prevention is receiving careful attention, that trees with eggs on them which were placed in heat about the middle of February were speedily found to have a full crop of caterpillars.

The non-effect of cold in doing what is called "clearing the grubs," has long been known scientifically, but it is still so little appreciated popularly that it appears worth while to note a few of these fresh field observations whilst they are still almost in progress.

With regard to considerations of prevention of Orchard Moth caterpillars (independently of weather influences), we now know, from observations of the past and previous seasons, that Winter Moths and other destructive kinds having wingless females may be found at intervals ascending the orchard trees, from somewhat before the middle of October until at least the end of March. These orchard observations clearly show that although "sticky-banding" is (as we all know) exceedingly serviceable for lessening the numbers of the great body of autumn and early winter ascending moth-pests, yet the constant complaints (such as are sent to myself yearly about May) from orchard-growers—that their trees are swarming with caterpillars, although they spared no pains in banding in autumn—have a cause beyond what autumn banding can possibly meet.

We see for ourselves, beyond what is laid down in entomological books, that there is enough presence of wingless moths to account for the subsequent attacks, besides what is owing to the presence of other kinds—as Lackey, Small Apple Ermine, Figure of 8, and other injurious kinds—which no "sticky-banding" will stop, because the moths come on the wing.

To meet this difficulty, although palliatives—such as shaking down caterpillars, smoke from specially-arranged fires, &c.—may sometimes be of use, no thorough remedy is known here, nor in the great fruit-producing countries of the world, excepting spraying the trees with insecticides of such a nature, and so applied, as will kill the whole collection of ravaging hordes at once without injuring the leafage or promise of fruit; and for this purpose the applications chiefly used, on the broad scale of United States and Canadian fruit-growing practice, have been emulsions of soft soap or applications of Paris green or London purple.

We have not tried the emulsions of soft soap on a large scale here, because there is great difficulty in so mixing the mineral oil and soft soap that they shall not presently separate and the application greatly injure the leafage. London purple, which, like Paris green, is an arsenical insecticide, has a capacity of doing much good, and in the coming season its use will probably be more widely tried. But the observations, which have now been con-

tinuously carried on from February in last year up to the present time with regard to the use of Paris green, have shown that in this country, as well as in the States and Canada, it may be applied mixed with water as a fine spray with excellent effects in clearing the caterpillars, without injuring the leafage, and without subsequent injury to the trees or anything else.

I am in constant receipt of information as to the working of these two insecticides, and shall be happy to give all information in my power on the subject to any applicant.

Amongst other attacks Clover-stem sickness is showing itself as usual, and in last week I had a portion of a warbled hide sent me showing that the year's mischief has already very badly begun. All these matters, and the usual routine of inquiries, I am attending to, to the best of my power.

ELEANOR A. ORMEROD.

*March 3, 1891.*

---

# Notes, Communications, and Reviews.

## THE COST OF WHEAT-GROWING

THERE has been much correspondence in agricultural papers lately as to the cost of growing wheat, and it is well known that the cultivation of wheat in the United Kingdom has been gradually falling off in area, during the last twenty years, until the home growth has become almost an unimportant item in the total requirements of the country.

Wheat is not so much grown, chiefly owing to the fall in price from an average of about 48s. per quarter, previous to 1880, to an average of 32s. per quarter, which may be taken as that of the last five years. This means, putting the crop at 28 bushels per acre, a loss of no less than 2*l.* 16s. per acre, or 6,954,066*l.* on the acreage of 1890, a loss that has to be borne in varying proportions by the landowner, the tithe owner, the farmer and the labourer. The purpose of this paper is to estimate how far the farmer's loss is made good to him by diminished cost of production, and with this object the following tables have been drawn up, to show the difference in the expenditure on growing an acre of wheat in the ten years previous to 1880, and the last five years.

	Before 1880			The last five years		
	£	s.	d.	£	s.	d.
Filling, carting, and spreading dung	10	0	.	10	0	.
Ploughing	10	0	.	10	0	.
Rolling	1	6	.	1	6	.
Dragging, 4s.; harrowing, 3s.	7	0	.	7	0	.
Drilling	2	4	.	2	4	.
Harrowing	1	0	.	1	0	.
Bird scaring, 1s.; spring roll, 1s.	2	0	.	2	0	.
Harvesting	15	0	.	15	0	.
Threshing, 7s. 6d.; dressing, 3s. 9d.; and marketing, 3s. 9d.	15	0	.	15	0	.
Carried forward	3	3	10	3	3	10

	Before 1890				The last five years		
	£	s.	d.		£	s.	d.
Brought forward							
Rent	1	5	0	30 % fall.	17	6	less 10 %
Tithes, rates, and taxes	10	0		25 % „	7	6	
Seed, 2 bush. @ 7s.	14	0		seed 2 bush. } @ 4s. 6d.	9	0	
	————— 2 9 0				—————		
	5 12 10				1 14 0		
	4 11 6				4 11 6		
	1 1 4			diminished cost of production.			
	£ s. d.				£ s. d.		
<i>Produce.</i>				<i>Produce.</i>			
28 bush. @ 48s. per qr.	8	8	0	28 bush. @ 32s. per qr.	5	12	0
Expenditure	5	12	10	Expenditure	4	11	6
	————— 2 15 2				————— 1 0 6		

The resulting diminished cost of production, 1*l.* 1*s.* 4*d.*, leaves 1*l.* 14*s.* 8*d.*, a deficiency that has to be put up with by the farmer as against his position prior to 1880. In other words, he made a profit in the first period of 2*l.* 15*s.* 2*d.* per acre; he now only makes 1*l.* 0*s.* 6*d.*

The first table is taken from the *Agricultural Gazette* of February 21, 1881; and it was then drawn up with the view of reducing the usual imaginary scale of expenses for growing an acre of wheat to a practical figure that might leave a margin of profit. In the second table it is estimated that there has been since, on corn-growing lands, a fall of rent of 30 per cent.; of tithes, rates, and taxes of 25 per cent.; and of labour, including money actually paid to the labourer, cost of horses, horse keep, and cost of implements and machinery, of 10 per cent.

There is no doubt a very considerable variation in the apparent cost of growing an acre of wheat in different parts of the kingdom, and there is also a very different result; but it may be allowed that when there is an increase of expenditure there is a more valuable crop, and that a cheaply-grown crop is not a heavy one. So that a generalisation is the only way to get at figures that are likely to be near the truth.

The fact of wheat being grown at a profit at all now is one not often admitted, and yet it cannot be that farmers have gone on year after year cultivating it at a loss. They have been much discouraged by the continual fall in price, and until rents, and tithes, and other expenses fell in sympathy, the crop certainly did not pay to grow; but now that there has been a general reduction, an average yield should apparently be profitable, though the small profit accruing does not leave much margin to balance the outlay on the crops that are frequently grown chiefly in preparation for wheat. Turnips fed off by sheep, and heavily manured, if followed by wheat should make it produce above the average; but unless the expense of the turnip tillage is spread over the rotation, it is impossible to regard

it as otherwise than exceedingly unremunerative. However, as the manuring, cleaning, and cultivation, and subsequent feeding off the land, where that custom prevails, are undoubtedly beneficial until the end of the rotation, it is not right to charge the whole loss in growing green crops to the next year. The same may be said with regard to the heavy dressing of farm-yard manure, which is usually applied to the ley ground ploughed up for wheat. It is certainly not nearly exhausted by the wheat, and its influence is seen through the succeeding course of cultivation.

In the table that has been quoted, no mention is made of manure further than the labour attached to it, it being assumed that the straw, the value of which is not taken into account, goes to make the farmyard manure ; or, if it is sold, that its equivalent is returned to the land in the form of bought dung or artificial fertilisers.

The aim of the cultivator of wheat must be to have his expenditure so low that there is an assured margin of profit. When that is accomplished, and when we can grow wheat remuneratively as cheaply as our foreign competitors, there appears to be no reason why our home acreage should not be gradually increased, so as to put the country generally into a sounder position as regards production of food, without in any way interfering with the doctrines of free trade.

To go back to quite another period, in comparing the various payments made by the farmer now with those in the time of Arthur Young, it is immediately noticeable that the gainer is the agricultural labourer. Though more must be allowed in the later figures for use of implements and machinery, the three following examples show the expenditure on labour to be 22*s.* 6*d.*, 27*s.* 7*d.*, and 33*s.* per acre, at the end of last century, against 63*s.* 10*d.* and 57*s.* 6*d.* at the present time.

*Arthur Young's Eastern Tour.*

Vol. I. p. 349. Doncaster, 1769.			Vol. II. p. 47. Norfolk, 1771.			Vol. III. p. 88. East Kent, 1771.		
	£	s. d.		£	s. d.		£	s. d.
One ploughing		5 0	One plough		3 0	Plough		7 0
2 harrowings		1 0	Seed and sowing		16 0	Seed and sowing		13 0
10 pecks seed		12 6	Manuring		1 5 0	Weeding		1 6
Sowings		3	Reaping and har-			Harvesting		10 0
Rent	2	10 0	vesting		7 6	Threshing		8 0
Harvesting		13 0	Threshing		5 0	Carrying		4 0
Threshing		6 8	Carrying		3 0	Rent	1	5 0
Carrying		1 8	Rent		12 0			
		<hr/>			<hr/>			<hr/>
		4 10 1			3 11 6			3 8 6
Produce, 30 bush.			Produce, 3 qrs. @			Produce, 4 qrs.		
@ 37 <i>s.</i> 4 <i>d.</i>		7 0 0	40 <i>s.</i>		6 0 0	@ 45 <i>s.</i>		9 0 0
Straw		1 10 0				Straw		15 0
		<hr/>						<hr/>
		8 10 0						9 15 0

These examples are chiefly interesting as showing that, more than a hundred years ago, the return was better than it is now, with a considerably lower outlay.

It is not easy to put a fixed sum on the wheat crop alone to

represent its cost of cultivation; an estimate only can be made, various other things being taken into consideration. In dealing with the new grounds of new countries, where they merely plough, sow, reap, and thresh year after year until the land is exhausted, there is no difficulty. But, grown as wheat is grown in England, one crop in a rotation, taking its share in the manuring, cleaning, sheep feeding, it is hard to do anything but to put the expense of the whole rotation on one side, and the receipts on the other. That, naturally, would be beyond the scope of this paper, which is more to find out whether the actual mechanical operation of growing and harvesting an acre of wheat, including rent, rates, and taxes, has become a cheaper one to nearly the same extent as the produce has declined in value.

The table quoted from the *Agricultural Gazette* of February 21, 1881, would have been considered before that time to be decidedly too low. It used to be a common saying that it would not pay to grow wheat for less than 50s. per qr., and then it came to be said that it could not be grown below 40s. per qr. At twenty-eight bushels, the money value of these two prices comes to 8*l.* 15*s.* and 7*l.* per acre, and both of them show a profit on an outlay of 5*l.* 12*s.* 10*d.* as in the table.

In reply to a circular sent to a few large growers of wheat, the answers show that the average from widely distant parts of England of the actual expense, without any charge for manure, is 4*l.* 11*s.* 7*d.* This is singularly near the estimate made of the last five years. The figures compare as under :—

	Average of answers		Last five years			
	£	s.	d.	£	s.	d.
Cultivation and seed . . . . .	. 1	19	1	1	19	6
Harvesting, threshing, and marketing . . . . .	. 1	4	1	1	7	0
Rent, tithe, rates, and taxes . . . . .	. 1	8	5	1	5	0
	4 11 7			4 11 6		

JAMES A. CAIRD.

## PINK EYE AMONG HORSES IN 1890.

INFLUENZA, in that peculiar form now known as "Pink Eye," has been largely prevalent during the past winter.

My attention was first directed to it in a large stud of horses in the north of England in October last, after which it spread in all directions, and there is perhaps hardly a provincial town of any size in which it has not prevailed to a greater or less extent. It also has been prevalent in many country districts, where serious losses have been sustained. In London the mortality, I believe, was never greater than during the recent outbreak. This has been shown by the plethora of dead horses received at the slaughtering establish-

ments of Messrs. Harrison, whose yards for several weeks were filled to repletion with carcasses. Horses of every description, under all circumstances and conditions of feeding and general management, both old and young, have been victims to the epizootic. Large studs, however, in populous centres, where many animals are crowded together under one roof, with indifferent ventilation and drainage, have suffered beyond comparison with those better managed and living under more wholesome conditions.

The existence of the epizootic during the Christmas season proved most disastrous to railway and tramway companies, parcel contractors, cab proprietors, job masters, and others whose business is so largely increased by holiday necessities. Here horses met the disease under the most adverse circumstances. Long hours, with consequent overwork, fatigue, and debility, do much to predispose to this, as to all specific fevers, to aggravate symptoms, and to bring about serious and fatal complications. Besides, it is rarely the case that establishments in populous industrial centres have the means of isolating the sick from the healthy; and, as a result, the disorder spreads from horse to horse until all or nearly all become its victims. Moreover, the mischief is usually added to when, as the result of disablement of some of the stud, others are called upon to do extra duty. These overwrought creatures, worn down by toil and fatigue, soon become receptive of the virus of the affection, and too often succumb to its influence. At such times as Christmas in town, and seedtime and harvest in the country, townsmen and agriculturists alike are disposed to risk the stud in the exigencies of the hour, and to disregard the early indications of disease. Such trifling, however, almost invariably adds to the mortality record.

The form of the disease recently prevailing was singularly free from those catarrhal symptoms which are commonly identified with influenza outbreaks. Discharge from the nostrils, soreness of the throat, and cough are quite exceptional phenomena in the course of the malady; and the more we see of the disorder, the more are we convinced that the term "influenza" embraces several febrile affections pathologically distinct from each other. The period of incubation—*i.e.* the time which elapses between the reception of the contagion and the manifestation of disease—varies somewhat in different cases, but it may be said to range between three and five days. All animals are not equally receptive of the disorder: some resist it altogether, others yield only after long exposure, and some contract it at once. A similar discrepancy is also observed with regard to its intensity, duration, and result. In one case it is mild and brief; in another it is severe, protracted, and fatal; while in yet another it runs its course rapidly, and quickly destroys life. This latter characteristic is especially the case where animals have been continued in work for a few hours after the onset of the disease.

In addition to the unfavourable conditions already enumerated, horses are predisposed to attack by any sudden change from country stables to the vitiated atmosphere of towns. Rarely have animals from the country entered the stables of our large firms and horse-



owners without speedily becoming affected with the epizootic. Great numbers of new purchases have fallen victims to the disease within a few days of their arrival, and have succumbed before entering upon the work for which they were intended. Overcrowding, inefficient ventilation, bad drainage, and various other causes which enfeeble the constitution and diminish its vital resistance, tend to augment the receptivity of the individual horse. Up to the present time, private stables have suffered comparatively little from the disorder. Increased air-space and good sanitary surroundings have proved a barrier against the disease, or, failing this, have tended to greatly shorten its duration and mitigate its effects.

Unlike the catarrhal form of influenza, there are in this disease few or no premonitions of its onset: hence it is that horses, apparently well in the morning, are found in the middle of a day's work suddenly manifesting symptoms of an urgent character. The onset of the affection is abrupt and severe—so much so that in two or three hours a horse is completely prostrated, and reduced from seeming health to a helpless invalid. Sudden and extreme prostration is the characteristic development of the early period of the disorder. In a short space of time the patient becomes dull and extremely depressed. There is lowering of the head, the eyelids droop, and the face wears an expression of extreme dulness and languor. At the same time, movements—formerly active and vigorous—become lethargic and feeble, and, less frequently, the gait is rolling and unsteady. In a state of rest the animal shifts the weight from one limb to another, and gives evidences of muscular pain and exhaustion. He will lie down for long periods, emitting now and again a deep moan; and if approached shows no disposition to resume the standing posture. Closer examination reveals a quick and feeble pulse; the breathing is more or less accelerated. The temperature of the body is heightened to the extent of three, four, or five degrees, and associated with this there is marked general prostration. The membrane of the eye is of a deep brick-red hue, and in some instances the structures of the eyelids are generally swollen, partly from the overloaded vessels and partly also from an escape of fluid into the tissues of the part. In extreme cases this dropsical state of the membrane causes the lids to be everted, or turned inside out, and there is a profuse discharge of tears. Thirst and lack of appetite are early symptoms in the attack, and for the most part the bowels are constipated.

In some outbreaks, however, and especially where animals have been closely packed in ill-ventilated and otherwise unsanitary stables, the digestive canal shows marked irritability and disorder. In other cases a foul stinking diarrhœa results, attended with signs of abdominal pain. In these examples of the affection the animal paws the ground, looks towards the flank, and repeatedly lies down in slight paroxysms of pain. These are unfavourable symptoms, and unless relief be quickly afforded a fatal termination to the case is much to be feared. A very striking clinical feature in the recent outbreak refers to the state of the bladder, which in

numerous instances has been found to be seriously involved in a general inflammation of the lining membrane. This has occasioned symptoms of abdominal pain (often referred to the bowels), and frequent staling and restlessness of the hind extremities. Swelling of the legs takes place early, and continues throughout the attack. The same condition may appear about the lips, beneath the breast, and along the course of the belly. Indeed, all the depending parts of the body show a disposition to dropsical effusion into the tissues. The duration of the disease varies from five to fifteen days. In favourable cases, symptoms of returning health are seen about the sixth day, when the head ceases to droop, the eyes become bright, a desire for food returns, and the swellings begin to disperse. The temperature of the body falls, and the pulse and respirations show a marked change both in number and character. In unfavourable cases, pulmonary complications most commonly arise in which the lungs become involved in a gangrenous or suppurative inflammation, ending in septicæmia (blood-poisoning) and death. Not infrequently pleurisy is added to pneumonia, or the disease centres itself in the large bowels and kills by gangrenous enteritis.

The proportion of animals attacked has varied considerably in different studs, depending upon special circumstances and management: in some it has not exceeded five to six per cent., while in others it has reached as high as seventy to eighty. Similar variations are noted in the mortality of the disease: in some studs it has not exceeded two or three per cent.; in others I have known it to reach as high as fifteen per cent. This greater death-rate is invariably identified with overcrowding and bad sanitation, and especially with an absence of means of segregation of the sick.

With reference to the treatment of influenza, it has to be borne in mind that it is essentially a febrile disease and, like all other specific fevers, runs a definite course. The symptoms above described are evidences of the struggle which is going on between the virus on the one side and the vital resistance of the animal on the other. Inasmuch as we cannot effectively assail the former, measures of treatment must be directed to strengthening and upholding the latter and guarding against complications which threaten in the course of the attack. The treatment of influenza, although in some individual instances simple enough, is not, from the broad standpoint of medicine, a duty to be undertaken by the amateur save at considerable risk. Numerous examples of serious and extensive losses due to amateur doctoring have recently been noticed. Much, however, may be done by the intelligent horse-owner to limit the spread of the disease, and by judicious nursing to assist the efforts of the veterinary practitioner.

Prompt and complete isolation of the sick from the healthy is of the first importance in dealing with this and other contagious disorders. The sick box or stable should be large and dry, with ample ventilation, and where practicable the temperature should be kept at between 55° and 60° Fahr. Good drainage and the frequent removal of all excrement, with general cleanliness, are important

adjuncts to medical treatment. In the summer months, when the weather is warm, the door of the stable may be thrown open ; and at all times provision should be made for the free entrance of fresh air. Protection from draught should be provided, and on no account should the animal be unduly exposed. To uphold the surface circulation and prevent internal congestions, the body should be well clothed and the legs enclosed in flannel bandages. The latter may be removed from time to time, and the legs briskly rubbed with a straw wisp ; but the body-clothing should on no account be completely taken off until the fever subsides.

In view of the prostrating influence of the disease, everything should be done to support the bodily strength. Any description of wholesome food may be allowed in small quantities, often repeated so long as the appetite remains. Cooked food, however, is preferable, if acceptable to the patient. Well-scalded oats and bran, with a fair amount of boiled linseed, form an agreeable and attractive diet for sick horses. This may be varied by scalded chaff and malt-meal. Should these be refused, the appetite may be tempted by a few carrots and old beans, or, in the summer season, by vetches, clover, rye-grass, and any other well-matured green foods. Rank, rapidly grown herbage should be avoided on account of its tendency to ferment and irritate the bowels. Medical treatment for the most part is to be directed towards subduing the fever and guarding against internal congestions. For this purpose, alcoholic stimulants or ethereal compounds are much to be preferred, and, in conjunction with saline diuretics, prove most efficient in lowering the temperature of the body. In some instances, where the bowels are much constipated, a small dose of sulphate of magnesia, given for two consecutive days, with a little aromatic powder, is usually sufficient to excite a gentle action in them. When the fever has dispersed and signs of returning health appear, convalescence may be completed by a course of iron tonics in combination with quinine or nux vomica. A plentiful supply of good food should now be offered, and slow walking exercise allowed if the weather is favourable ; but the too early resumption of work should on no account be permitted.

J. WORTLEY AXE.

---

## MARKET RIGHTS AND TOLLS.

THE Royal Commission on Market Rights and Tolls, which began its work in July 1887, presented its final report to Parliament on January 15, 1891. I had the honour of being appointed as one of the Assistant Commissioners, and as such I visited and reported upon some eighty markets in England, including Bolton, Bradford, Carlisle, Hull, Leeds, Newcastle, Norwich, Sheffield, and Sunderland, and had the opportunity of hearing from local authorities and market frequenters of all classes their opinions on most of the

subjects referred to the Commission. It is impossible here to deal exhaustively with all the evidence which was collected, for it occupies ten volumes; but it may nevertheless be instructive to examine some of the more important conclusions which have been arrived at by the Commissioners. It is unfortunate that several of these conclusions are not unanimous, so that there will in all probability be but little legislation on the subject, but for the present we may well content ourselves with the practical lessons which can be learnt from them.

By far the most important conclusion is the first :

That it is desirable to put an end to the system under which no person is allowed to hold a market within a certain distance of an already existing market, due regard being had to the interests of the present possessors of the monopoly rights.

This goes to the root of our present system of markets, and is agreed to by seven only out of the twelve Commissioners, whilst it is rejected by five. It is said by the majority that the Market Monopoly obviously belongs to a state of society wholly different from that of the present day, because the restriction of a six-mile limit by which it is guarded is quite unsuited to the rapid means of transit and communication which now exist, and there is no longer the same desire that each locality should have its own commercial centre. I do not think, however, that this conclusion necessarily follows from the premisses. It may be conceded that the old monopoly right cannot be justified, but it does not follow that all monopoly rights are therefore undesirable. The question is one of a purely practical character. Can a successful public market be established and maintained without some sort of monopoly rights? This is a matter upon which each person is certainly entitled to his own opinion, for, except in the United States, the experiment has not yet been tried. In the United States, as will be seen on p. 17 of the Report, a Market Monopoly is unknown, and the result has been twofold: first, public markets have fallen into disuse, and have given way before private enterprise; secondly, there is no longer any control exercised by the State or Local Authority over markets, except for general purposes of health and police regulations. The power of establishing markets still exists, but it is not exercised by the municipal authorities. I do not know whether the majority of the Commissioners have considered the possibility of such a result following from their conclusion, but I should suppose not, as the rest of their resolutions point to the abolition of private enterprise in markets, and to the establishment of greater control by Local Authorities. The answer given on this point by Mr. Little, who dissents from the opinion of the majority, is as follows (p. 124):—

The case of markets appears to be analogous to that of a gas or water undertaking. They exist for the convenience and advantage of the public; they are frequently established and developed at considerable cost of capital, for which no immediate return can be expected, and no extension of the public market system can be looked for if the privilege which has hitherto attached to markets be withdrawn.

Much the same reasoning is used by Mr. Allanson Picton and Mr. Pierce Mahony. On p. 125 they say :—

The advantages of a market to the community very much depend on the concentration of business in one place ; and this is largely contingent on the existence of those ancient rights. They may be objectionable when in private hands, but when held by representatives of the whole community, they may be so used as to facilitate local trade.

· Sir James Corry and Sir Thomas Martineau say on p. 123 :—

In the nature of the case it is impossible in practice to avoid market monopolies altogether. It must be remembered that a market essentially differs from a shop, the former depending on a concourse of both sellers and buyers. It is therefore impossible to make an indefinite increase of markets in any particular place, and any attempt to do so, while it might inflict serious injury on established markets, would confer no corresponding benefit on the community.

These arguments of the minority are supported by the experience obtained from the United States, and appear to me to be convincing. A choice must be made between private enterprise practically uncontrolled, on the one hand, and, on the other, public markets with monopoly rights, regulated as to charges, bye-laws, production of accounts, and restraint as to leasing, &c. There can be no doubt that the evidence which has been collected in regard to general markets is overwhelmingly against the system of private enterprise, because it leads to excessive charges, and constant disputes between the market owners and the general public. It is for this reason that the Commissioners unanimously recommend in their third conclusion :

That the Local Authorities, whether in county or borough, ought to be empowered to purchase markets now in private hands, either by agreement or by compulsion.

It is not difficult to appreciate the reason for this. If the town does not provide or regulate the market, it will have no interest in supporting it. The owner must make all that he can out of it ; and the less accommodation he provides within reason, the greater may be the competition for places ; because, when all is said and done, the farmers and vegetable growers will certainly try to sell within a walking or driving distance of their homes if possible. The idea of bad accommodation and high tolls is abhorrent to all the Commissioners, and they, therefore, resolve, not only that all market owners should make bye-laws subject to the Local Government Board, but that the stall-holders should have a right of appeal against excessive charges to the County Council. If the market monopoly is abolished, the market owner enjoys no privilege, and the public can no longer claim the right to control the management or the charges for the use of the market. If the terms of one market owner do not suit the stall-holders they must seek another, and there is nothing for them to complain of.

But, it is argued, if there is a desire for a local commercial centre, the ratepayers will not be slow to provide it. I doubt this,

No provident local authority would invest the ratepayers' money upon a concern which might at any moment prove to be an absolute loss, owing to the competition of private enterprise. I will illustrate what I mean from my experience in some of the towns which I visited in my capacity of Assistant Commissioner. In Leeds the capital expenditure upon markets is variously estimated at 162,268*l.* and 288,549*l.*, with the result that the Market Committee is unanimously against allowing private competition. It will be seen on p. 449 of Vol. IV. presented with the Report, that the Committee prevents auctioneers from selling cattle outside the market, although the auctioneers are willing to pay the market toll, which they consider a perfectly reasonable demand. At Bedford there is an excellent cattle market belonging to the town on a space of three and a half acres, but only three-quarters of the space is used, because the principal trade in sheep and pigs is carried on at a private auction mart close by. At Ripon no attempt is made to create a satisfactory public cattle market, because private individuals have been allowed to obtain prescriptive rights of market. At Sunderland the general markets are carried on at a loss of 300*l.* a year, partly because a private market has been allowed to establish itself in a more central position. At Spennymoor a rival market has arisen within a quarter of a mile of that belonging to the Local Board, but outside the district of the latter, and the result has been disastrous to the prosperity of the market (Vol. IV. p. 369).

Mr. Ashton, one of my colleagues as Assistant Commissioner, reports as to Basingstoke that "the cattle market has been crushed by the establishment of an auction mart within the town" (Vol. III. p. 385). It is evident from these examples—and many others might be cited—that free competition may ruin public markets, and that the ratepayers are not very likely to risk their money if such competition is to be allowed. Thus one of the principal objects which the Commissioners have in view, namely, that of placing markets generally under the control of local authorities, will not be attained.

Before leaving this part of the subject, I ought perhaps to point out in greater detail the objections which are made to the monopoly. These are illustrated on p. 83 of the final report by a *résumé* of a successful action brought by the owner of the Spitalfields Market against the Great Eastern Railway Company. The defendants in that case were prevented from establishing what might have proved a very useful market for the sale of roots and vegetables in London, because it happened to be within 3½ miles of a chartered market. I would say of this case that it does no doubt show the objection to any hard-and-fast lines by way of restriction, but it does not prove that the absence of all restriction is likely to be beneficial.

Further evidence as to the objection to the monopoly is given on pp. 60 to 63, where restrictions on the sale of goods outside the market are dealt with. It is clear that some of these cannot be justified, as, *e.g.* the regulation at Penrhyn that butchers shall not be allowed to sell in their own shops on market days. The chief question raised by these restrictions, however, is as to the

treatment of hawkers. Mr. Ashton says, on p. 61, that in the West of England the general markets are unable to compete with hawkers, and he is of opinion that for purposes of protection it is desirable that hawkers should pay toll or take out a licence, which he justifies on other and more general grounds. The question of hawkers will be dealt with hereafter, but I may say here that in my experience I found no instance of the price of food being enhanced by tolls upon hawkers, whereas I did find several cases of markets injured by an unrestricted system of hawking. Further, in my opinion, there is nothing so effective as a successful and flourishing market for the cheapening of food.

I have not yet said anything as to the last words of the conclusion—"due regard being had to the interests of the present possessors of the monopoly rights"—but they are very important. With regard to them there is even greater diversity of opinion among the Commissioners, and upon them is founded another suggestion, namely, the appointment of a Market Commission to determine the amount of compensation. Five of the Commissioners, who belong to the original majority, are of opinion that the sums adjudged to be due for the abolition of such rights should be paid to the holders out of the Public Funds. Lord Balfour of Burleigh thinks that such matters, being of purely local concern, should be paid for out of the local rates, without any grant from the Imperial Funds. Mr. Childers prefers no compensation at all by pecuniary payment, but he would allow to the owners, in certain cases, extension of the monopoly for a limited number of years. Sir James Corry and Sir Thomas Martineau agree with Lord Balfour of Burleigh as to Imperial Funds, but they think it would be most objectionable that Local Authorities should be compelled to burden themselves, "not for the purchase of a valuable privilege, but for an unproductive payment in respect of rights that have disappeared." I think the use of the word "compelled" is a mistake; but Mr. Little says, "It would be hopeless to expect that the ratepayers with whom the decision must rest would ever sanction the expenditure of money in purchasing, establishing, or enlarging markets, if the Market Monopoly be abolished." With this opinion I entirely agree, and the conclusions of Mr. Picton and Mr. Mahony are practically the same. This shows that under any circumstances there must be great difficulty in getting rid of the Market Monopoly; and some idea of the magnitude of such an undertaking may be gathered from the fact that at Sheffield the Duke of Norfolk possesses markets upon which he has spent 200,000*l.*, and his agent thinks it would be unfair to buy him out at 40 years' purchase. At Bradford, again, the Corporation pays to a Miss Rawson a rent of 5,000*l.* a year for the privilege of working the markets.

I need not enlarge upon this point, for the mere difficulty of an undertaking is no argument against its principle; but it may be useful to consider whether the suggested appointment of a Market Commission depends solely upon the abolition of Monopoly Rights. I think not. Resolution 24 reads as follows:—

That a Markets Rights Commission, to endure for such time as may be necessary, and to be constituted in such manner as Parliament may determine, be appointed to hear and decide all questions referred to or arising out of the foregoing resolutions.

It must be admitted that many rights have been proved to exist in England, Scotland, and Ireland, which nobody but an antiquarian or an interested ratepayer would attempt to defend. These are summed up in the sixth resolution as "Octrois, transit tolls, and all restraints whatsoever of an analogous character, on free sale, purchase, and carriage." Putting aside what I have already alluded to in regard to competitors with the market, there is very little doubt that these rights must go, and, as they are to be paid for, it is well that a Special Commission should be appointed to deal with them.

Particular examples may be usefully cited. At Newcastle an income of 5,541*l.* is obtained from a through toll which was originally granted for repairing the streets. The cost of such repairs is now provided for by a general rate, but the income is maintained for the purpose of relieving the rates. These tolls are a nuisance to everybody, but there is a difficulty in abolishing them, because they have been mortgaged for 120,000*l.* (see p. 10 of Vol. IV.). Similar tolls exist at Carlisle and at Cork, the income derived from them in the first city being 1,256*l.* a year, and in the second 2,370*l.* The corporations are naturally reluctant to give up these incomes, but they do not pretend to justify the toll which is "collected upon all goods, cattle, carts, waggons, &c. ; or upon all kinds of grain and agricultural produce passing into one or other of these cities." The same remarks apply to the Shore Placks, or Plack Dues, at Dundee. This is a duty levied upon all sorts of victuals or food, grain, flour, wheat, barley, oats, oatmeal, &c. at the rate of 8*d.* a ton on all such goods loaded or unloaded in the port of Dundee (see pp. 63 to 67 of the Report). This is obviously objectionable, and is one of the many difficulties which the Commission would have to deal with. But whether the Market Monopoly be abolished or not, the Commission would certainly find occupation in determining the compensation to be paid by Local Authorities for the purchase of markets now in private hands, besides determining the principle on which charges in a market are to be made, as suggested in the sixteenth resolution.

After the abolition of Monopoly Rights, by far the most important conclusion is that all markets should as soon as possible pass into the hands of Local Authorities, and that when once in the hands of such authorities, they should not be given up to any other body. This subject is dealt with in the third, fourth, fifth, eleventh, and fourteenth resolutions, and has already been alluded to in the discussion of the monopoly principle. It has this point in its favour, that the Commissioners are unanimous about it, and the only question in dispute is as to whether Local Authorities should be compelled to purchase or be allowed to exercise their discretion. Four of the



Commissioners appear to be in favour of compulsion. Sir James Corry and Sir Thomas Martineau say, p. 123 :—

We are of opinion that the most practical and effective reform lies in the direction, not of the abolition of market monopolies, but of the transfer of all of them now in the hands of private individuals, or self-elected trustees, to the responsible representatives of the inhabitants in their different local areas of government.

Mr. Picton and Mr. Mahony say, p. 125 :—

All public markets now in the hands of trading companies or corporations other than municipal should be taken over by Local Authorities; and the latter, if necessary, should be compelled by legislation to acquire them.

In support of this view may be cited the opinion of the late Mr. Bradlaugh, who says (p. 71)—

that the Local Authorities should be empowered and required by law to acquire all existing rights to hold markets, to levy tolls, and to make regulations in connection with markets.

It is noteworthy that the desire for compulsory powers seems to be nearly universal amongst Local Authorities, but in practice “considerably less than one-half of the markets in England and Wales are under the control and management, or in the possession of Local Authorities” (p. 69). This question of compulsion is a matter of great importance, but it does not sufficiently bear upon the character of markets to justify further discussion in these pages.

What is of more importance to consider is whether, assuming the markets to be in the hands of Local Authorities, they should be what are called “free markets”—in other words, whether market accommodation should be provided by Local Authorities free of charge. Mr. Picton and Mr. Mahony are the only Commissioners who deal with this subject directly; they say, p. 125 :—

Local Authorities should not be allowed to apply the profits of markets to the reduction of rates; but, beyond a small margin for contingencies, all excess of profit over expenses, interest, and sinking fund, should go to reduce market rates, tolls, and stallages, and to improve accommodation.

That is almost exactly the opinion of Mr. Bradlaugh, whose views appear on p. 110, and are of great interest, because he was the originator of the Markets Commission, and no doubt started it with this object. It is curious that, with the exception of Mr. Bradlaugh, there is hardly a person of any importance whose evidence can be cited in favour of this principle; but in practice it is difficult to find any places where the authorities have acted in any other spirit.

The reason is this: the rate of tolls is not allowed to be excessive in any case, and wherever the revenue from tolls is large the capital expenditure upon markets has been so great that the revenue barely provides for the maintenance and necessary extension of the market, together with a sinking fund for repayment of capital in a period of 30 or 40 years. However, the question of principle must be answered, and it is a difficult one. Why should the shopkeepers

of a town pay rates for the purpose of providing accommodation for their rivals? The answer given by the advocates of the principle is, that it is necessary for every town to provide food for its inhabitants at the cheapest possible rate. To this it is replied, on behalf of the ratepayers, that if all market tolls were abolished to-morrow the consumers would not be perceptibly benefited. Mr. W. H. Talbot, the Deputy Town Clerk of Manchester, says of his Council :

We see no justice in such a suggestion. This is property which has been paid for and is used without extortion or without unfairness. We think also that it would open the door to great abuse in the shape of favouritism and corruption of all kinds, and we do not think the consumers would be perceptibly benefited by it.

Mr. Fulford, the Chairman of the Markets Committee at Birmingham, says :—

I have no doubt that the benefit obtained by the reduction of tolls would go into the pockets of the sellers.

This is important testimony, and it is corroborated by the evidence obtained from almost every market owner in the kingdom. Such profits, moreover, can never be large, and are the natural reward of a careful and generous administration.

Next in order to free markets it is natural to consider very shortly the subject of free hawking. This is a larger subject than would at first sight appear, and in nearly every town is the cause of constant consideration and frequent dispute. The difficulties connected with it range from the important question of serious injury to the town market by competition to the comparatively unimportant question of annoyance to foot passengers by obstruction. The question certainly ought not to be ignored in any Bill which professes to deal exhaustively with markets. It is not directly dealt with by the majority of the Commissioners, but free hawking is no doubt implied in the abolition of Monopoly Rights. Mr. William Little says of it (p. 124) :—

The practice of hawking is generally permitted under certain conditions, but some amendment of the law in this particular seems desirable. I would suggest that Local Authorities, being market owners, should have the power of regulating hawking by issuing permits or licences to hawkers under conditions approved by the Local Government Board.

Mr. Picton and Mr. Mahony say (p. 125) :—

Hawkers should be freed from the charges imposed on them in the interest of markets.

I much prefer the opinion of Mr. Little, and so does Mr. Ashton ; and I think it will be found that our opinion is in accordance with the views of most market authorities, and very generally of the hawkers themselves. The first hardly requires illustration, but I may state that not only did I receive many complaints of unfair competition, and obstruction of the streets, but health officers often gave evidence to show that without some system of licences there was no protection against the sale of unwholesome food, whilst Chief

Constables stated that unlicensed hawkers were often tramps or thieves in the disguise of traders. Of the second I will give one illustration. At Newcastle I received a deputation of costermongers, whose spokesman, Mr. Charles Smith, made this curious complaint (Vol. IV. p. 25) :—

We feel that we should like to take out a licence. We feel we are not respected as we should be, as other people in the same line in other towns are. We wish to pay a small sum a-year for a licence, that would cause a more respectable class of people to engage in our trade. It would do away with children sellers; it is disgraceful to see that sort of thing going on in this town compared to other towns.

Many hawkers and costermongers have expressed to me the same opinion, and it seems to me reasonable to expect that persons who pay something, however small, for the privilege of using the streets of a town for the purpose of trade would be more respected as a class by the inhabitants than those who pay nothing.

The remaining subjects dealt with in the Report belong to administration rather than to general principles of government, but are of great importance to farmers and others who depend upon markets. Resolution 21 says, and with it few will be inclined to quarrel :—

That all inequalities of charges in respect of persons or trading classes should be prohibited, except upon account of special advantages of position or accommodation. All exemptions of persons from market charges to cease.

Resolution 22 says :—

That money payments in all cases should be substituted for tolls in kind.

It is sad to part with old friends, which remind us of the good old days of Pie Poudre Courts, but ready money is a great consoler, and we will say farewell to tongues of oxen, eggs, pints of corn, and the rest of them, with a good grace.

A matter of much current interest is embodied in Resolution 23 :

That markets which are now required to be provided with machines for weighing cattle should be furnished with sufficient and suitable accommodation for the same, the question of sufficiency and suitability to be determined by the Board of Agriculture, after inspection.

I am entirely in favour of this method of selling cattle, but I found very little support for it in the markets which I visited. At Wakefield, which is one of the largest markets in England for home-bred cattle, there is one weighbridge, but it is scarcely ever used. It takes about ten minutes to weigh a beast upon it, so that about six beasts only could be weighed in an hour; and yet I was asked to believe that it was "sufficient and suitable." To become popular this system must be made as simple and convenient as possible, and it should be taken for granted, in providing accommodation, that every farmer is a wise man, and will sell his cattle by live weight if he can find a machine.

Two or three other points deserve notice. Resolution 26 says—

That it is desirable to collect statistics of the market prices of meat, and in particular that the prices of cattle at per stone, live weight, should be collected (in the same manner as the prices of corn are now returned) in such markets as may be selected for the purpose by the Board of Trade.

Also in Resolution 25 we read—

That it is desirable to collect statistics of market prices of commodities through the agency of market owners as far as possible.

A great deal of evidence upon this subject has been collected both at home and abroad, and is referred to on pp. 111–118.

The last resolution I will call attention to is number 18 :—

That all powers given to Local Authorities in respect of markets by the Public Health Act should be extended so as to include fairs.

This is a very simple and necessary reform.

The limits of space prevent my giving to several subjects the attention which they merit ; but I hope I have said enough to show that the Royal Commissioners have expended much labour upon the subject entrusted to them, and have shown great skill in presenting the result of that labour to the public.

CECIL M. CHAPMAN.

## THE QUALITY OF BARLEY.

THE deterioration in the general quality of the barley of recent years growth is a matter sufficiently serious to demand careful investigation. Undue richness in nitrogenous ingredients confers upon the barley grain a quality which is liked neither by maltsters nor by brewers. There exists an opinion that heavy artificial manuring may be accountable for an excessive percentage of nitrogen in barley. It is possible, too, that barley grown upon land which immediately previously has carried sheep, generously fed with cake, may likewise show too high a proportion of nitrogenous matter. The subject obviously is one for discussion ; still more is it one for experiment. In anticipation that the problem will receive full investigation, certain facts and opinions are here recorded.

In his opening address on November 11, 1889, as President of the Surveyors' Institution, Mr. E. P. Squarey, after quoting the low average prices of English barley, proceeded "to call attention to a matter of grave moment to farmers and landowners disclosed in these figures. The average value of barley for ten years, from 1860 to 1870, was 36s. 1d. per quarter, and 26s. 7d. per quarter for 1886–7–8, whilst the average up to September 1, 1889, is only 25s. 4d. This variation appears to be due rather to a degradation of quality than to those causes of cheapened transport and increased areas of cultivation which have tended to reduce the value of wheat

and oats, inasmuch as the sources of supply of the best imported barley are of comparatively limited area and production. The inferior qualities of barley (certainly an exceptionally large proportion of the growth of 1888), being generally consumed on the farms, are not included in these results, and the omission of their values increases *pro tanto* the stated average. Hence English barley, ranging thirty years ago from 35s. to 42s. per quarter, now compares with an average of about 26s. per quarter, whilst the Bavarian and French barleys are currently selling from about 48s. to 50s. per quarter in Mark Lane. I suggest, then, as a most important area for inquiry, the causes of this generally lowered character and quality of barley now, as compared with that currently grown thirty years since. This degradation in quality cannot be tabulated, but my inquiries amongst corn-dealers, maltsters, and farmers, having experience of the last thirty years in all parts of England, tend to confirm the view that really fine, 'kindly,' samples of barley are now the exception where formerly they were the rule.

"The seasons have not permanently changed, the efforts to obtain the best varieties and samples of seed are persistent, and every method and variation of cropping has been tried, and yet, as I have said, the Burton brewers and maltsters are paying 45s. to 50s. per quarter for the rare best English and foreign barleys, as against the miserable average of 25s. of our markets! And no indisposition exists to use the home growths if, as formerly, good quality were obtainable in sufficient quantity."

The foregoing furnishes a practical view of the subject, as it concerns English growers. More recently it has been brought prominently and officially under the notice of French cultivators. In several of the memoirs in the *Etudes agronomiques* (1891), Professor L. Grandeau reverts to the matter, and his salient observations are here placed at the disposal of English readers.

The extension of the brewing industry, and the steadily increasing demand for beer on the part of the people of European countries, are facts commended to the consideration of the cultivators of France, a country in which the area under barley has been well-nigh stationary for a quarter of a century. The annual production of barley in France does not much exceed one-half that of Britain, whilst the average yield per acre in France is only about 57 per cent. of the corresponding yield in this country. M. Tisserand, Directeur de l'Agriculture, has endeavoured to account for this position of the barley-growing industry in a country naturally well supplied with good barley soils. He instances three facts: (1) barley yields but little straw; (2) for a long time barley grain had a value only about half that of wheat; (3) not much beer is brewed in France. For these reasons French growers have neglected barley, preferring to devote their energies to the cultivation of wheat, as being in France the more remunerative crop. But the conditions cited are no longer maintained. Every day prime samples of barley are more and more in request; the price of barley, if only of medium quality, is three-fourths of that of wheat; and good malting barley

frequently commands a figure equal to that of wheat. As, moreover, the yield of barley per acre is about one-third more than that of wheat, this is an additional argument in favour of barley. That which has been accomplished by the barley-growers of Bohemia and Moravia by careful cultivation, the selection of the best seed, and the judicious application of manures, is equally possible in France, where so much benefit has already resulted from the application of scientific principles to the culture of wheat and sugar-beet. But it is to the production of the best, and none but the best qualities of barley, that all efforts in the way of improvement should be directed.

Having thus dealt with the subject in its general aspects, M. Grandeau proceeds, in a subsequent memoir, to discuss a question of high practical interest, namely, as to how far it is expedient in the cultivation of barley to employ nitrate of soda as a fertiliser. A trade journal, the *Revue industrielle de la Brasserie et de la Malterie*, commenting on the disastrous results produced in brewing, by the use of malt made from barley in the manuring of which nitrate of soda has been employed, stated that brewers and maltsters were forming a league for the proscription of nitrate of soda, and for demanding a guarantee that barley offered for sale shall have been grown without the application of nitrate. The journal alluded to derives support for its contention from a case, recorded in the *Chemiker Zeitung*, in which one of the largest brewers of Heilbronn purchased a considerable quantity of barley grown upon a farm which enjoyed the reputation of producing excellent grain. The sample was, indeed, of fine marketable quality, and yet the first beer it yielded was of too inferior a character to be utilised. Some of the barley was therefore sent to Hohenheim for analysis, with the result that the grain was declared to be too rich in nitrogenous matter for brewing purposes. The question then arose as to the origin of this excess, and it was suggested that nitrate of soda had been freely used in manuring the crop. Inquiry at the farm confirmed this suggestion. Eventually the brewer disposed of the barley by selling it at a heavy loss to a distillery. The case, says the *Chemiker Zeitung*, is not an isolated one, nor, it adds, need it cause surprise.

It is evident that M. Grandeau is somewhat sceptical as to the influence exercised by nitrate of soda, used as a fertiliser, upon the malting quality of barley. He mentions that there are scarcely more than a dozen recorded comparative analyses of the grain of cereals (wheat, barley, and rye) grown in the same soil, with and without nitrate of soda. These, however, show a slight excess—from 0.96 to 1 per cent.—of nitrogenous matter (protein) in the grain grown with nitrate. It is difficult to believe that this small difference in the percentage of nitrogenous ingredients can account for such unfortunate results as those at the Heilbronn brewery.

Recognising the importance of the subject in farming districts devoted to the growth of malting barley, it is suggested that the problem be investigated in the field. Two adjoining areas, previously cultivated and manured in the same way throughout, should be

sown with barley of choice quality, the one area receiving, however, nitrate of soda, and the other farm-yard manure. The grain from the crops should be delivered separately to a maltster, and the beer from the one would be compared with that from the other.

Looking below the mere surface of the question, it is necessary to remember that by far the most important source of the nitrogen of the cereals is afforded by the nitrates contained in fertile soil. In whatever form, such as farmyard manure, dried blood, poudrette, shoddy, &c. nitrogen may be applied to the land, this element becomes available to crops only after the nitrogenous matter has run the gauntlet of the chemical changes which result in the production of a nitrate. These changes require for consummation varying periods of time, depending upon the temperature, the humidity, and the aeration of the soil, the nature of the raw manure, and so forth. But eventually the nitrate is produced. What, therefore, is the difference between applying nitrate of soda directly to the soil and waiting for the nitrification of crude organic matter? The difference is simply and solely one of time—the period necessary for nitrification is suppressed. There is, in effect, no change in the method of nutrition of the cereals. In the one case, as in the other, they acquire, in the state of nitrate, nitrogen needful to their development. It is true that the administration of the dose can be more accurately timed in the case of nitrate of soda. It is under the genial influence of the warmth and the light of April and May that the vegetative growth of the cereals reaches its maximum intensity, and it is at this period that the cultivator puts at the disposal of the crop the largest quantity of immediately assimilable nutriment.

Finally, M. Grandeau considers that judgment should be reserved till rigorous field experiment has demonstrated whether or not the brewing quality of barley is controlled by the nature of the fertilisers in which nitrogen is presented to the crop. He therefore urges that this season, for the information and in the interest of agriculturists, maltsters, and brewers alike, comparative experiments should be made. Upon one part of a field of barley nitrate of soda should be top-dressed as usual; upon the other part no nitrate should be applied. The brewing qualities of the resulting samples of grain would then be tested and compared.

It should be remarked that it is probable that brewers and their chemists know more about this matter than M. Grandeau suspects; and it is, of course, possible that barley grown with too much farm-yard manure may prove as unfit for malting purposes as that grown with too liberal a dressing of nitrate.

Significant as this problem may be to French barley growers, it is still more so to English cultivators. Attention is therefore directed to M. Grandeau's suggestions, and the season is yet sufficiently early for them to be put into operation in connection with the crop now occupying the land.

---

## PERMANENT AND TEMPORARY PASTURES.

Of the total area of land in England under all kinds of crop, bare fallow, and grass, more than 51 per cent. is in permanent grass. Of the similar cultivated area in Great Britain, permanent grass covers nearly 49 per cent. Approximately, therefore, half of the agricultural area of this island is in grass, so that the interests associated with grass farming are obviously great. It is to the present and prospective farmers of grass land that Mr. Sutton's work<sup>1</sup> specially appeals, and its inherent merits are such that it has not appealed in vain, for it has passed into a fourth edition in less than five years from the date of its first appearance.

The book is, in its entirety, a happy illustration of "Practice with Science." Primarily, it is a practical book written by a practical man for practical men. But Science, as the handmaid of Practice, sheds her light upon its pages, and the result is in the highest degree instructive. The early chapters deal with the drainage of grass land, cultural preparations, and the selection of grasses and clovers. The main part of the book is then occupied with descriptions of the species of plants commonly found in meadows and pastures. Next follow instructions for the spring and autumn sowing of grass seeds, the immediate after-management of new pastures, and the management and improvement of old grass land, as well as the breaking up of such land. The sections on hay-making, on grazing, and on the conversion of grass into silage, are replete with sound suggestions applicable in the field. An important division of the work is that dealing with temporary pastures, whether one, two, or three years' ley, or intended to remain down for from four to eight years.

Amongst the agricultural grasses which are figured and described are fiorin, foxtail, sweet vernal, yellow oat grass, tall oat grass, dogstail, cocksfoot, seven species of fescue, perennial rye-grass, Italian rye-grass, timothy, and four species of meadow grass (genus *Poa*). The leguminous plants dealt with are five species of *Trifolium* (white clover, red clover, cow-grass, alsike, and yellow suckling), together with common trefoil, birdsfoot trefoil, lucerne, and sainfoin. Yarrow and sheep's parsley likewise receive attention. The descriptive accounts of these various species are models of conciseness and correctness, and will be appreciated alike by the farmer and the student. The tone of the entire volume, indeed, is such as to qualify it for the field rather than the bookshelf, though as a reference manual it has no equal.

The two dozen coloured plates of grasses and clovers are skil-

---

<sup>1</sup> *Permanent and Temporary Pastures, with Descriptions and coloured Illustrations of leading Natural Grasses and Clovers.* By Martin J. Sutton. Fourth Ed. Pp. xii and 172, with 23 coloured plates. London: Simpkin, Marshall, and Co. 1891.



fully executed, and, like all true works of art, they are true to nature. Each plate is faced by a technical description of the species, accompanied by an analytical table showing the chemical composition of the plant. Woodcuts representing front and side views of the "seeds" of the grasses, natural size and magnified, will be found of great assistance to cultivators who wish to avoid sowing adulterated samples of seed.

Readers who are familiar with the modern literature of this subject, whether French, German, or American, will find it difficult to name any foreign work worthy of being ranked side by side with this admirable volume. The secret of its high quality is perhaps to be found in the circumstance that it has been a work of slow growth, based upon the accumulated experience of many years. More than a quarter of a century has elapsed since Mr. Martin Hope Sutton, the father of the author, contributed to this Journal a paper on the same subject, which has been expanded into the valuable manual now under notice. That it should have been the good fortune of an Englishman to write a work that has taken a front place in the "grass literature" of the world is a circumstance that must prove as gratifying to the author as it must be satisfactory to his brother agriculturists.

---

## THE WEATHER OF 1890.<sup>1</sup>

**First Quarter.**—The weather in *January* was very cold for the first three days, the temperature on the 1st being as much as 9°·7 below its average; then from the 4th to the end of the month it was remarkably warm, being above its average on the 6th, 7th, 12th, 13th, 15th, 16th, and 25th days, by 13°·4, 12°·3, 10°·6, 10°, 10°·4, 10°·3, and 10°·7 respectively, and on several other days it was as much as 7° and 8° above. The atmospheric pressure was below its average from the 18th to the 28th, being as much as three-quarters of an inch below on the 22nd, and nearly 1·2 inch below on the 23rd, and it was generally above on other days. The fall of rain was slightly above its average at all stations, and the S.W. wind was prevalent.

The weather in *February* was warm for the first two days, and then generally cold, dry, and with frequent frost for the rest of the month. The temperature of the air was above its average on the first two days, then below till the end of the month, with the exception of the 16th, 17th, and 18th days, when it was 3°·4, 0°·9, and 0°·7 respectively above. The atmospheric pressure was above its average from the 1st to the 11th, and from the 18th to the end of the month, being nearly three-quarters of an inch above on the 23rd. The fall

<sup>1</sup> Abstracted from the particulars supplied to the Registrar-General by James Glaisher, Esq., F.R.S., &c.

of rain was small. Snow fell on several days. Cold E. and N.E. winds prevailed.

The weather in *March* was for the first five days bitterly cold, the temperature of the air for these five days being nearly  $14^{\circ}$  below their average. The last instance of such low temperature about London in March was in the year 1845. The atmospheric pressure was below its average from the 5th to the 26th, and above on the other days, being particularly below on the 16th, when it was more than three-quarters of an inch below its average. The fall of rain was above its average at some stations and below at others, and the S.W. wind was prevalent.

**Second Quarter.**—The weather in *April* was mostly dry, with cold E. and N.E. winds. The temperature of the air was generally below its average, a few days only exceeding their averages. The atmospheric pressure was above its average during the first five days, and generally below during the remainder of the month. The fall of rain at a few stations slightly exceeded the average, but was below at most stations. The sky was generally overcast. It was a month very favourable for farming operations.

The weather in *May* was variable, but on the whole fine. Till the seventh day the weather was warm, then cold for two or three days, then warm to the 25th, which day and that preceding, viz. the 24th, were hot, and from the 26th the weather was cold to the end of the month. The atmospheric pressure was below its average till the 20th, and above it from the 21st. The fall of rain was generally above its average. Very cold winds prevailed from the 26th to the end of the month. The month was favourable for agricultural pursuits.

The weather in *June* was cold and wet. The temperature of the air was nearly constantly below its average. The atmospheric pressure was below its average from the second day to the 6th, and from the 26th, and was generally above on other days. The fall of rain was generally above the average. There were but a few fine days in the month, and the showery weather at the latter part of the month was bad for hay-making.

**Third Quarter.**—The weather in *July* was cold, dull, and wet. The temperature of the air on two or three days only was at about its average, on all other days it was below, and at times to as much as  $11^{\circ}$  or  $12^{\circ}$ . The atmospheric pressure was below its average till the 19th day, and was generally above from the 20th. The fall of rain was above its average at most places. On the 17th the fall was excessive, amounting to three inches at many places in the counties of Middlesex, Hertfordshire, and Berkshire. The fall of rain spoiled much hay, and generally the month was unfavourable for the hay crop.

The weather in *August* was cold, wet, and sunless. The temperature of the air was generally below the average; the 1st and the 5th were the only warm days in the month; the second half of the month was very cold, particularly from the 24th to the end. The

atmospheric pressure was below its average from the 10th to the 29th, particularly so from the 23rd to the 29th, and it was generally above its average till the 9th and on the 30th and 31st. The fall of rain was above the average at all stations. The bad weather of this month most seriously checked harvest operations; the corn was damaged both by wind and rain.

The weather in *September* was very fine, warm, and dry, with clear skies and bright sunshine. The temperature of the air till the 14th was generally a little below the average, the 5th and 6th were warm, as were the 10th and 11th, but to a less degree; from the 15th every day was warm and above its average mean temperature. The atmospheric pressure was below its average from the 16th to the 22nd, and above it on every other day. The fall of rain was small, and there was almost a freedom from both fogs or mists at many stations. The month was very favourable for gathering in the late harvest.

**Fourth Quarter.**—The weather in *October* was very fine and dry. The temperatures of the air during the first week and the last two days were above their averages, and below generally from the 8th to the 29th, particularly so on the 26th, 27th, and 28th days. The mean temperature of the 28th was  $16^{\circ}$  below its average, and it was the coldest day in October for many years. The atmospheric pressure till the 30th was above its average, with the exception of two or three days. The fall of rain was small.

The weather in *November* was generally fine and mild till the 24th, when very severe weather set in and continued. The temperature of the air differed but little from the average till the 12th. It was warm from the 13th to the 24th, and particularly on the 19th, 20th, and 23rd days, the mean temperature of these three days being exceptionally warm for the time of year, averaging fully  $10^{\circ}$  above their averages. On the 25th the temperature fell quickly, to the 28th, when the mean temperature at Blackheath was  $20^{\circ}\cdot 2$ , being  $21^{\circ}\cdot 4$  below the average, and the mean depression of temperature below their averages for the six days ending the 30th was  $14\frac{1}{4}^{\circ}$ . The atmospheric pressure was below its average till the 13th, and was above from the 14th, with the exception of the 23rd, 24th, and 25th days. The fall of rain was below its average about London, but was in excess at many stations in the Midland and Northern Counties.

The weather in *December* was very cold, with frequent fog and light snow. The cold was remarkable for its persistency and severity. On many days the deficiency of temperature below average exceeded  $12^{\circ}$ , on the 14th it was as large as  $17\frac{3}{4}^{\circ}$ , and on the 22nd as large as  $21^{\circ}$ . The atmospheric pressure till the 14th was for two or three days together below its average, and then for two or three days above; from the 15th to the 19th it was below, and above from the 21st. The fall of rain was small. The month is remarkable as being the coldest December in this century.

## THE GREAT FROST OF 1890-91.

THE recent prolonged period of severe cold, the extraordinary dryness of the month of February, and the blizzard of the second week of March, have introduced some disturbing factors into the normal phenomena associated with an English winter. What effect such unusual factors will produce in the succeeding summer remains to be seen. Meanwhile, the concurrence of frost and drought is being made the subject of careful investigation on the part of meteorologists. A valuable contribution to the inquiry was submitted to the Royal Meteorological Society at its meeting on February 18, by Mr. Charles Harding, F.R.Met.Soc., through whose courtesy the diagrams on pages 197 and 199 are presented. The labour involved in the preparation of Mr. Harding's paper, "The Great Frost of 1890-91," was very great, the author having found it necessary to work up the daily observations made with verified instruments at about 150 stations in the British Isles, and also at a number of Continental stations.

The frost prevailed from November 25 to January 22, a period of 59 days. It was most severe over the south-eastern counties of England, where the mean temperature for the entire spell was more than  $2^{\circ}$  below the freezing point, Cambridge having a mean of only  $28.5^{\circ}$ , whilst at seaside stations on the coast of Kent, Sussex, and Hampshire, the mean was  $32^{\circ}$ . In the extreme north of Scotland, as well as in the west of Ireland, the mean was  $10^{\circ}$  higher than in the south-east of England. In the southern Midlands, and in parts of the south of England, the mean temperature for the fifty-nine days was more than  $10^{\circ}$  below the average, but in the north of England the deficiency did not amount to  $5^{\circ}$ , and in the extreme north of Scotland it was less than  $1^{\circ}$ .

The cold, in fact, decreased gradually in a northerly and westerly direction, the Shetlands being  $11^{\circ}$  warmer than Cambridge, the Hebrides  $10^{\circ}$ , Valencia  $13^{\circ}$ , and Scilly  $13\frac{1}{2}^{\circ}$ . In the north-east, north, and west of Scotland, and the north-east of Ireland, the deficiency of temperature was less than  $2^{\circ}$ .

The lowest authentic reading was  $0.6^{\circ}$  at Stokesay, Shropshire, on December 22, and at Rounton, Yorkshire, on January 18; but almost equally low temperatures occurred at other periods of the frost. At many places in the south and south-west of England, as well as in parts of Scotland and Ireland, the greatest cold throughout the period was registered at the end of November; and at Waddon, in Surrey, the thermometer fell to  $1^{\circ}$ , a reading quite unprecedented at the close of the autumn. At Addington Hills, near Croydon, the thermometer was below the freezing point each night, with one exception, and with only two exceptions at Cambridge and Reading, whilst in the Shetlands there were only nine nights with frost, although at Biarritz frost occurred on thirty-one nights, and at Rome on six nights. At many places in England the frost was continuous night and day for twenty-five days, but at coast stations

# THE GREAT FROST OF 1890 -- 1891

ISOTHERMS AND VALUES  
SHOWING MEAN TEMPERATURE  
FOR WHOLE PERIOD

FROM  
25<sup>TH</sup> NOV: 1890 TO 22<sup>ND</sup> JAN: 1891.

DEFICIENCY OF MEANS  
FROM 20 YEARS' AVERAGE  
IN DEGREES FAHRENHEIT  
FOR WHOLE PERIOD.



in the north of Scotland there was not a single day on which the frost remained unbroken.

All round the coasts of the kingdom the sea-water was warmer than the air during the month of December, according to the records received from the lightships. On the Sussex coast the excess was 14°, on the north-east coast 6°, and off the Shetlands and round Ireland about 3°. Two feet below the surface of the Thames at Deptford the temperature of the water was continuously below 34° for thirty-two days, December 23 to January 23, the river being blocked with ice during the greater part of this time.

In Regent's Park, where skating continued uninterruptedly for forty-three days, the ice attained a thickness of over 9 inches.

Thermometers fixed at various depths in the soil, in different parts of the British Islands, showed that the frost had nowhere penetrated as far as 2 feet into the ground, but, in the south and east of England especially, there were several days on which it was recorded at a depth of one foot, whilst at 6 inches the ground was frozen for a month.

The subjoined table gives details of the prolonged frosts of the last hundred years, from which it will be seen that in the neighbourhood of London, the cold was of longer duration than in any previous frost during the last century. The next longest spell was fifty-two days in the winter of 1794-5, whilst in 1838 frost lasted for fifty days, and in 1788-9 for forty-nine days; neither the mean nor the minimum was, however, so low as in several previous cases. It is important to note that nearly all the prolonged frosts of the last century were followed by a fairly dry spring and summer, but the accompanying weather was by no means always hot.

PROLONGED FROSTS OF THE LAST CENTURY, FROM OBSERVATIONS  
MADE IN LONDON AND ITS VICINITY.

Date	Days duration	Mean maximum	Mean minimum	Mean of maximum and minimum	Absolute minimum	Days					Absolute maximum
						With minimum temp. below 20 deg.	Of continuous frost	With daily mean 32 deg. or below	With maximum temp. 32 deg. or below	With maximum temp. 40 deg. or above	
1788-9 Nov. 26 to Jan. 13	49	deg. 31·3	deg. 27·5	deg. 29·4	deg. 17·5	4	12	33	30	3	deg. 46
1794-5 Dec. 18 to Feb. 7	52	31·9	25·3	28·6	7	11	12	35	23	3	46
1813-4 Dec. 26 to Feb. 5	42	33·0	21·5	27·3	8	16	11	32	20	5	41
1838 Jan. 5 to Feb. 23	50	32·9	24·9	28·9	-4·0	9	13	31	19	5	50
1855 Jan. 10 to Feb. 25	47	34·8	24·5	29·7	11·1	12	4	31	15	7	48
1860-1 Dec. 15 to Jan. 19	36	34·9	24·8	29·9	8·0	8	3	26	9	4	47
1879 Nov. 14 to Dec. 27	44	37·2	24·7	31·0	13·7	4	2	22	6	12	55
1881 Jan. 7 to 26	20	31·8	22·1	27·0	12·7	10	9	14	12	1	41
1890-1 Nov. 25 to Jan. 22	59	33·5	25·0	29·3	12·0	10	10	41	27	9	44

1 The frost of 1788-9 has been included, as it occurred but little more than 100 years ago. The temperatures, however, are not from self-registering thermometers, but the observations used as the maximum were made at 2 P.M. and those for the minimum at 8 A.M. each day. The observations for all other periods are from self-registering thermometers.



The left-hand map on page 197 is intended to indicate, by means of isotherms and values, the mean temperatures over the United Kingdom for the whole period of the frost. The figures denote the temperatures, and the lines the various limits of—under 30°, 30° to 32°, 32° to 34°, 34° to 36°, 36° to 38°, and 38° to 40°. An isothermal line, it may be observed, is a line drawn through places possessing the same temperature—in this case the same mean temperature.

The great difference between the temperature of Scotland and Ireland, and that of England, is explained by the fact that during the whole period there was a large area of high barometric readings over Europe, which maintained an almost permanent position. The incoming disturbances from the Atlantic could not make headway into Europe, but skirted to the westward of our islands, their centres keeping well out in the Atlantic. Consequently our western coasts felt the warming influence of these disturbances, although the weather remained comparatively quiet. England, especially its eastern parts, was not at all affected by these disturbances.

The right-hand map on page 197 is designed to show the deficiency of the mean temperatures for the period of the frost, when compared with the averages of twenty years past. At Greenwich the mean was 9.5° below the average, and in some parts it was more than 10° below, while in the extreme north of Scotland it was approximately in agreement with average conditions.

It is a noteworthy fact that, as may be learnt from the diagram on page 199, on only one day—January 13—was the mean daily temperature at Greenwich in excess of the average daily mean for sixty years. Indeed, the frost was throughout remarkable on account of the absence of any high temperatures.

---

## RECENT AGRICULTURAL INVENTIONS.

*The subjects of Applications for Patents from Dec. 15, 1890, to  
March 14, 1891.*

N.B.—Where the Invention is a communication from abroad, the name of the Inventor is shown in italics, between parentheses, after the name of the applicant.

### **Agricultural Machinery and Implements, &c.**

No. of Application.	Name of Applicant.	Title of Invention.
Year 1890.		
20443	COCKER, J. N.	Potato-harvester.
20457	BARLOW, H. B. ( <i>Richards &amp; Carley</i> )	Automatic grain-weighers.
20589	TOPP, G. C.	Mowing and reaping machine.
20602	BONNÉ, C. R. ( <i>Heinsdorf</i> )	Testing quality of grain or seeds.
20696	BROWN, T.	Beater bar for threshing machines.
20739	BRADBURY, J.	Forming, binding, &c. trusses or sheaves.
20837	CHANDLER, A.	Apparatus employed in mowing and reaping,



No. of Application. Year 1891.	Name of Applicant.	Title of Invention.
137	BAYLY, J. P. ( <i>Magers</i> )	Apparatus for sharpening knives of reapers, &c.
140	" " ( <i>Webster</i> )	Cutting seed potatoes.
141	" " ( <i>Wilkin</i> )	Harvesters.
449	BOUSFIELD, E. T.	Baling hay and straw.
1081	STEPHENSON, G. & C.	Pressing hay, &c.
1276	VIGREUX, L.	Triturating straw, &c. for cattle.
1418	LANZ, H.	Threshing machines.
1442	TURNER, T. H.	Self-cleaning cylindrical wire-screens for grain, &c.
1685	BAWDEN, R.	Ploughs.
1724	LANDISS & JENNER	Threshing machines.
1889	ROE, J. P.	Spades for weeding and transplanting.
1917	BOARDMAN and others	Apparatus for planting potatoes.
1952	STARK, A.	Cord-knotters for grain-binders.
1973	COLE, W.	Harvesting machines.
1984	COTTIS, C.	Lawn-mowing machines.
2243	STRETTON, W. G.	Potato-sorting machines.
2292	NEEDLEY, F.	Threshing machines.
2350	THOMÉ, J. E.	Horse-rakes.
2980	EDWARDS, E.	Stirring and turning over malt by electricity.
3151	FRY, H. W.	Crushing or pulverising grain, &c.
3158	SHEARER and another	Land-grabbers.
3366	MATTHEWS, E. C.	Sheaf-binding harvesting machines.
3418	MUNNS ( <i>Pike</i> )	Mowing machines.
3506	ROWE, G. E.	Mowing and reaping machines.
3808	TOOTH and others	" " "
3861	DYSON	Composition for tillage purposes.
4058	CHANDLER, T. H.	Seed-drills.
4213	FRIEDERICH, P.	Corn-planters.
4439	PRING, J. E.	Hay-rakes

### Stable Utensils and Fittings—Horse-shoes, &c.

Year 1890.

20427	MURCHIE, H.	Horse-shoe.
20500	DAVIES & ATKINSON	Stopping runaway horses.
20539	BOULT ( <i>Théron</i> )	Roughing horses.
20579	DOLMAN	Stirrups.
20691	KENRICK & SCILLY	Safety stirrup-bar.
20700	LAKE ( <i>Simmons and anr.</i> )	Flooring for stables.
20723	CLARKE, T. U.	Safety stirrup.
20733	TATE, J.	Controlling horses.
20762	BOULT ( <i>Cottel</i> )	Harnessing horses and driving vehicles.
20870	BARTZ, E.	Arresting escaping horses.
21063	STRAUSSLER, J.	Shoes for horses, &c.
21146	ALLISON ( <i>Turney</i> )	Stopping runaway horses.
21179	STEEL, J.	Tethering horses, &c.
21223	MEYER	Bridle-bits.
21298	HUNTOON	Horse-neck pokes.
Year 1891.		
35	DAVENPORT, J.	Roughing horses, &c.
43	HOPE, H. C. & J. H.	Attachment to horse-shoes to prevent slipping.
61	WEBB, G. E.	Adjustable saddle-girth.
94	RAMSTER, T.	Saddle-trees.
106	WAYMOUTH, W. J.	Horse-shoes.
149	BAYLY ( <i>Magraw</i> )	Horse-blanket fastener.
178	MCKENNY, J.	Bit for horses.
197	WEED, R.	Horse-shoes.

No. of Application.	Name of Applicant.	Title of Invention.
Year 1891.		
270	ATKINSON, G. B.	Feed-bags for horses, &c.
273	CRONK, G.	Horse-shoes.
307	ALCOCK & OATES	"
313	HEIL, A.	"
338	HOOK, E.	Horse-clipping machines.
487	WALCH, E. J.	Horse-shoes.
562	SCOFIELD, E. W.	Spring horse-shoe clip with pad.
803	BINARD, V.	Stopping runaway horses.
831	CHAMBERLAIN & NASH.	Securing and releasing horses, &c. to and from stalls.
850	WINGRAVE, W. V.	Attachments for roughing horse-shoes.
1008	PAGE, M.	Fastening horse-shoes by adhesive substances.
1026	REYNOLDS, W. R.	Spring hooks for lessening jerks, &c., to draught horses.
1062	HÜBNER, W.	Safety reins and bridle.
1093	DUNKLEY, H.	Safety stirrups.
1245	BENFIELD, J., and others	Horse-shoes.
1266	KNIGHT, A. W.	"
1321	KING, G.	"
1331	MUNNS, W. H. ( <i>Marshall</i> )	Preventing horses knocking their hind legs together.
1487	CHAPMAN & MERRITT	Heel-expander for horses.
1562	GLOSSOP, J.	Horse-collars.
2047	TEMPERLEY, J.	Safety stirrup attachment.
2094	HORNSBY, G. S.	Roughing attachment for horses.
2110	FOULKES, R., and others	Horse-shoes.
2291	HOFER, F.	Tightening device for saddle-girths.
2367	NOIRAUT, B. J.	Horse-shoes.
2532	BAILEY, E.	Saddle-cloths and saddles.
2861	POLL & BENNETT.	Nose-bag.
3119	MACKLEY, G. T.	Shoes for horses.
3370	RUTTER, A. T.	Breastplate and neck-strap for horses.
3742	CLARKE & SEYMOUR	Safety stirrup.
3875	BARAWITZKA, G.	Preventing horses from running away.
4204	EASTON, H.	Reins for controlling and driving horses.
4441	BITTEN, G.	Pneumatic horse-collar.
4530	ZELLERIN and anr.	Harness.

### Carts and Carriages.

Year 1890.

20676 WEBB, H. & F. . . . Vehicles for lightening draught and easing horses' shoulders.

Year 1891.

959 THOMPSON, W. P.  
(*Gouldberg*) . . . Farm waggons.

1346 BOISRENOULT, G. H. . . . Vehicles for distributing, &c. manure.

1857 MULLETT, W. G. . . . Brake for two-wheeled vehicles.

1931 CHESTERTON, W. J. . . . Whip-socket.

3944 KENNEDY, J. . . . Chapel or dog-carts.

### Dairy Utensils, &c.

Year 1890.

20626 BAYLY (*Jordan and Porter*) . . . Motor for churns.

21068 SALENIUS, E. G. . . . Manufacture of butter.

20920 WHITEMAN & COX . . . Filtering milk.

No. of Application.	Name of Applicant.	Title of Invention.
Year 1891.		
279	BUCKLEY, I.	Churns for butter-making.
498	SCHAFFTER, M.	Milking apparatus.
713	HANLY, M. M.	Instrument for testing milk.
1547	RUSSELL, and another	Apparatus for making butter.
2038	HOPE, J.	Appliance for cutting cheese.
2175	GIBSON & CAMERON	" "
2195	WILLIAMSON, J. T.	Milk-can protector.
2709	NICHOLSON & GRAY	Milking machine.
2955	MUNNS ( <i>Kneeland</i> )	Packing and transporting butter.
3415	EVDENDEN, R. E.	Centrifugal churns.
3841	HULT	Cream-separators.
3842	STUBÉ & MAX SPIRO	Process to increase the value of whey.
3920	EVANS, G. P.	Cheese-vats.

### Poultry and Game, &c. Appliances.

Year 1891.

1468	THE BRADFORD AND DISTRICT RABBIT, CAT, &c. SOCIETY and others	Poultry pens.
1607	LANE, W. N.	Artificial brooders for chickens.
1683	LANE, W. N.	Incubator-cases.
2777	ASHMORE & WILMORE	Crushing apparatus for preparing birds' food.

### Miscellaneous.

Year 1890.

20594	FIRMIN, G.	Attachment to hurdles, &c., for sheltering.
20695	BICHON and anr.	Preventing disease in potatoes, &c.

Year 1891.

1516	COLE, W.	Facilitating the shearing of sheep.
2036	SILVER, W.	Shearing or clipping hair or wool.
2220	LANG, G.	Fencing in of farmyard and produce.
2665	HANCOCK, T. F.	Covering for hay-stacks, &c.
2720	BOULT, A. J. ( <i>Pallas</i> )	Feeding cake for cattle.
2802	ROBERTS, F. S.	Machinery for shearing and clipping.
4072	STEINBACH, A. R.	Muzzle for dogs.
4416	OUTRAM, O. A.	Drenching Bottle.

### Numbers of Specifications relating to the above subjects Published since December 13<sup>1</sup>

(with prices in parentheses).

1373 (6 <i>d.</i> ), 1392 (6 <i>d.</i> ), 1448 (6 <i>d.</i> ), 1455 (6 <i>d.</i> ), 2317 (8 <i>d.</i> ), 2403 (6 <i>d.</i> ), 2565 (6 <i>d.</i> ), 2686 (8 <i>d.</i> ), 2726 (8 <i>d.</i> ), 2780 (6 <i>d.</i> ), 2884 (8 <i>d.</i> ), 3002 (6 <i>d.</i> ), 3049 (8 <i>d.</i> ), 3134 (4 <i>d.</i> ), 3218 (6 <i>d.</i> ), 3545 (8 <i>d.</i> ), 3709 (6 <i>d.</i> ), 3779 (8 <i>d.</i> ), 3851 (11 <i>d.</i> ), 4167 (6 <i>d.</i> ), 4233 (6 <i>d.</i> ), 4278 (6 <i>d.</i> ), 4279 (6 <i>d.</i> ), 4381 (6 <i>d.</i> ), 4554 (4 <i>d.</i> ), 5134 (8 <i>d.</i> ), 5221 (6 <i>d.</i> ), 5357 (6 <i>d.</i> ), 5391 (6 <i>d.</i> ), 5395 (8 <i>d.</i> ), 5528 (6 <i>d.</i> ), 5885 (8 <i>d.</i> ), 6962 (8 <i>d.</i> ), 7986 (8 <i>d.</i> ), 8551 (4 <i>d.</i> ), 10269 (6 <i>d.</i> ), 10828 (8 <i>d.</i> ), 12904 (6 <i>d.</i> ), 13005 (8 <i>d.</i> ), 13912 (6 <i>d.</i> ), 14215 (8 <i>d.</i> ), 14417 (4 <i>d.</i> ), 14530 (6 <i>d.</i> ), 15380 (8 <i>d.</i> ), 15435 (8 <i>d.</i> ), 15897 (8 <i>d.</i> ), 16454 (6 <i>d.</i> ), 16708 (8 <i>d.</i> ), 16754 (6 <i>d.</i> ), 17144 (6 <i>d.</i> ), 17413 (8 <i>d.</i> ), 17632 (6 <i>d.</i> ), 17768 (8 <i>d.</i> ), 17781 (6 <i>d.</i> ), 17907 (6 <i>d.</i> ), 17959 (6 <i>d.</i> ), 18183 (8 <i>d.</i> ), 18911 (6 <i>d.</i> ), 19663 (8 <i>d.</i> ), 19799 (6 <i>d.</i> ), 20066 (6 <i>d.</i> ), 20691 (6 <i>d.</i> ), 20870 (6 <i>d.</i> ).
---

<sup>1</sup> Copies may be obtained at the Patent Office (Sale and Store Branch), 38 Cursitor Street, London, E.C.

# THE PRICE OF WHEAT IN 1890.

AVERAGES FOR 1890.

	s.	d.
Wheat	31	11
Barley	28	8
Oats	18	7

THE annual Imperial average price of wheat has risen 2s. 2d. a quarter above that of 1889. In the latter year the annual average was 29s. 9d., whereas in the past year it was 31s. 11d.; in 1888 it stood at 31s. 10d. The weekly fluctuation has also been greater, ranging 6s. 10d.; in 1889 it was 3s. 3d. and in 1888 8s. 1d. The lowest weekly average for the past year was 29s. 8d. on March 22, and again on April 5. The highest weekly average was 36s. 6d. on August 16. The highest weekly average for the past two years was in the month of August. The price of barley has exceeded that of wheat in several weeks in the past year, but it has never been higher than 32s. 3d. a quarter, on January 18; the lowest was 22s. 6d. on July 5; so that the fluctuation (9s. 9d.) has been greater than in the case of wheat. The fluctuation in oats was 3s. 2d.; highest 20s. 5d., on August 9; lowest 17s. 3d., on October 18. The annual Imperial average price of corn during the past year was:—Wheat, 31s. 11d.; barley 28s. 8d.; oats, 18s. 7d. The septennial tith rent-charge is 1l. 17s. 11½d. lower this year than last, it being in 1889 78l. 1s. 3½d., whereas this year it is 76l. 3s. 3½d. per 100l.—lower than it has ever been. The average from the commutation in 1836 is 100l. 13s. 2½d.

HENRY ALLNUTT,

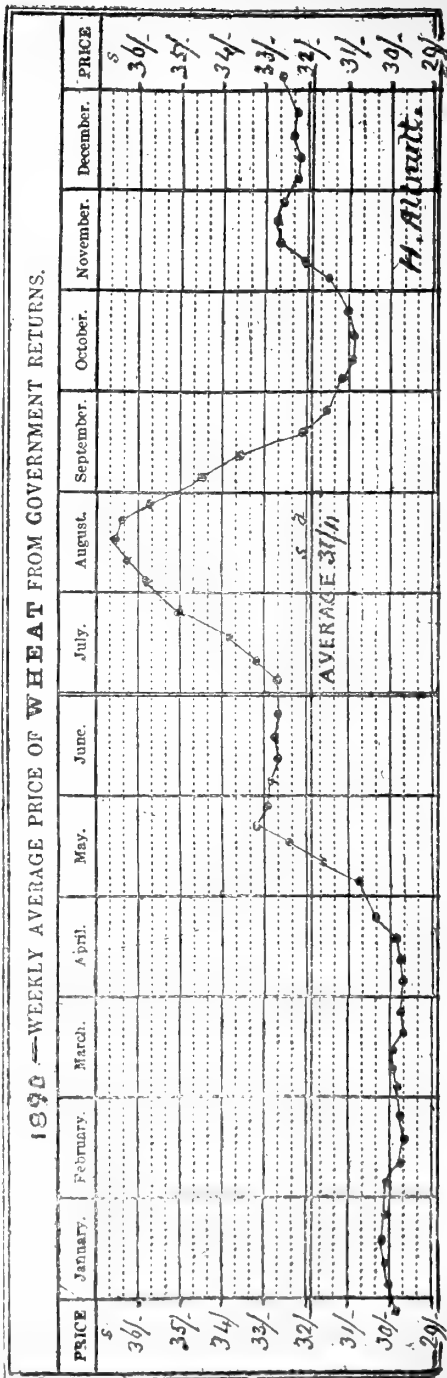

Each space between the horizontal lines indicates fourpence.

## STATISTICS AFFECTING BRITISH AGRICULTURAL INTERESTS.

TABLE I.—AVERAGE PRICES OF BRITISH CORN PER QUARTER (Imperial measure) as received from the Inspectors and Officers of Excise conformably to the Act of 45 & 46 Vict. ch. 37, in each week of the year 1890.

[From the "London Gazette."]

Week ending	Wheat		Barley		Oats		Week ending	Wheat		Barley		Oats	
1890	s.	d.	s.	d.	s.	d.	1890	s.	d.	s.	d.	s.	d.
January 4 . . . . .	30	0	30	5	18	3	July 5 . . . . .	32	8	22	6	19	10
January 11 . . . . .	30	1	31	5	18	4	July 12 . . . . .	33	2	24	2	19	4
January 18 . . . . .	30	2	32	3	18	4	July 19 . . . . .	33	10	24	6	19	6
January 25 . . . . .	30	1	32	2	18	7	July 26 . . . . .	35	0	25	2	19	10
February 1 . . . . .	30	1	32	2	18	6	August 2 . . . . .	35	10	23	4	20	4
February 8 . . . . .	29	9	31	10	18	7	August 9 . . . . .	36	3	24	5	20	5
February 15 . . . . .	29	8	31	8	18	7	August 16 . . . . .	36	6	25	4	20	3
February 22 . . . . .	29	9	31	2	18	6	August 23 . . . . .	36	5	26	2	20	1
March 1 . . . . .	29	10	30	11	18	8	August 30 . . . . .	35	9	31	3	19	2
March 8 . . . . .	29	11	30	9	18	6	September 6 . . . . .	34	6	30	11	19	1
March 15 . . . . .	29	11	30	8	18	6	September 13 . . . . .	33	7	30	3	18	8
March 22 . . . . .	29	8	30	4	18	7	September 20 . . . . .	32	1	29	11	17	9
March 29 . . . . .	29	9	29	10	18	6	September 27 . . . . .	31	6	29	9	17	8
Average of Winter Quarter )							Average of Summer Quarter )						
29 11 31 2 18 6							34 5 26 8 19 5						
April 5 . . . . .	29	8	30	0	18	1	October 4 . . . . .	31	2	29	5	17	5
April 12 . . . . .	29	9	29	9	18	6	October 11 . . . . .	30	11	29	3	17	5
April 19 . . . . .	29	10	29	10	18	6	October 18 . . . . .	30	10	29	7	17	3
April 26 . . . . .	30	4	29	2	18	6	October 25 . . . . .	31	0	29	10	17	3
May 3 . . . . .	30	9	27	9	18	8	November 1 . . . . .	31	6	29	7	17	3
May 10 . . . . .	31	7	28	3	19	2	November 8 . . . . .	32	1	29	5	17	3
May 17 . . . . .	32	5	27	7	19	3	November 15 . . . . .	32	8	29	3	17	6
May 24 . . . . .	33	2	30	5	19	10	November 22 . . . . .	32	9	28	11	17	8
May 31 . . . . .	32	11	26	5	19	10	November 29 . . . . .	32	7	29	0	17	8
June 7 . . . . .	32	10	25	1	19	8	December 6 . . . . .	32	3	28	9	17	10
June 14 . . . . .	32	8	25	7	20	0	December 13 . . . . .	32	2	28	5	17	10
June 21 . . . . .	32	9	24	11	19	11	December 20 . . . . .	32	4	28	8	17	6
June 28 . . . . .	32	8	26	0	19	6	December 27 . . . . .	32	3	28	5	17	11
Average of Spring Quarter )							Average of Autumn Quarter )						
31 7 27 9 19 1							31 11 29 1 17 6						

TABLE II.—ANNUAL AVERAGE PRICES AND QUANTITIES OF BRITISH CORN sold in the Towns in England and Wales from which Returns are received under the Corn Returns Acts, in each of the Years 1880 to 1889.

[From the "London Gazette."]

Year	Wheat		Barley		Oats		Wheat Qrs.	Barley Qrs.	Oats Qrs.
	s.	d.	s.	d.	s.	d.			
1880	44	4	33	1	23	1	1,607,908	1,591,925	164,791
1881	45	4	31	11	21	9	1,738,255	1,631,504	211,444
1882	45	1	31	2	21	10	1,903,858	1,873,820	211,699
1883	41	7	31	10	21	5	2,901,146	2,575,528	408,471
1884	35	9	30	8	20	3	2,833,132	3,149,341	492,918
1885	32	10	30	2	20	7	2,739,515	2,765,500	393,042
1886	31	1	26	7	19	0	2,739,822	2,474,466	367,083
1887	32	6	25	4	16	3	2,495,124	2,589,667	309,478
1888	31	10	27	10	16	9	2,427,861	1,911,835	255,726
1889	29	9	25	10	17	9	2,945,408	3,329,814	415,783
1890	31	11	28	8	18	7	3,439,699	3,327,991	599,033

TABLE III.—Returns published pursuant to the Corn Returns Act, 1882, and to Act of 6 & 7 Wm. IV. for *Commutation of Tithes in England and Wales*, showing what has been, during the Seven Years ending Christmas Day in each Year, the AVERAGE PRICE of an IMPERIAL BUSHEL of British Wheat, Barley, and Oats, computed from the Weekly Averages of Corn Returns in each of the years 1884-90.

[From the "London Gazette."]

Year	Average (Septennial) prices per bushel					
	Wheat		Barley		Oats	
	s.	d.	s.	d.	s.	d.
1884	5	4 $\frac{3}{4}$	4	1 $\frac{3}{4}$	2	9
1885	5	1 $\frac{3}{4}$	3	11 $\frac{3}{4}$	2	8 $\frac{1}{2}$
1886	4	11	3	10	2	7 $\frac{1}{2}$
1887	4	8 $\frac{1}{2}$	3	8 $\frac{1}{2}$	2	6 $\frac{1}{4}$
1888	4	5 $\frac{1}{2}$	3	7 $\frac{1}{2}$	2	5
1889	4	2 $\frac{1}{4}$	3	6 $\frac{1}{4}$	2	4 $\frac{1}{4}$
1890	3	11 $\frac{1}{4}$	3	7	2	3 $\frac{3}{4}$

TABLE IV.—AVERAGE PRICES OF WOOL IN EACH OF THE UNDER-MENTIONED YEARS.<sup>1</sup>

Year	ENGLISH								AUSTRAL- ASIAN	SOUTH AFRICAN
	Leicester		Half-breds		Kent		Southdown			
	Per lb.	Per lb.	Per lb.	Per lb.	Per lb.	Per lb.	Per lb.	Per lb.		
1884	8 $\frac{3}{4}$	to 9 $\frac{1}{4}$	9	to 9 $\frac{1}{2}$	9	to 9 $\frac{3}{4}$	10	to 11	1 0 $\frac{1}{2}$	1 1 $\frac{1}{2}$
1885	8 $\frac{1}{2}$	" 9	8 $\frac{3}{4}$	" 9 $\frac{1}{2}$	9	" 9 $\frac{1}{2}$	9	" 10	0 10	0 9 $\frac{1}{2}$
1886	9	" 9 $\frac{3}{4}$	9 $\frac{1}{2}$	" 10 $\frac{3}{4}$	9 $\frac{3}{4}$	" 10 $\frac{1}{2}$	9 $\frac{1}{2}$	" 10 $\frac{1}{2}$	0 9	0 9 $\frac{1}{4}$
1887	9 $\frac{3}{4}$	" 10 $\frac{1}{4}$	10	" 11	10 $\frac{1}{4}$	" 10 $\frac{3}{4}$	10 $\frac{1}{2}$	" 11	0 10 $\frac{1}{2}$	0 10
1888	9 $\frac{1}{4}$	" 10	9 $\frac{1}{2}$	" 10 $\frac{1}{2}$	9 $\frac{1}{2}$	" 10 $\frac{1}{4}$	9 $\frac{3}{4}$	" 11	0 10 $\frac{1}{4}$	0 9 $\frac{3}{4}$
1889	9 $\frac{3}{4}$	" 10 $\frac{1}{2}$	10 $\frac{1}{4}$	" 11	10 $\frac{1}{4}$	" 10 $\frac{3}{4}$	10 $\frac{1}{4}$	" 11	0 10	0 10 $\frac{1}{4}$
1890	9 $\frac{3}{4}$	" 10 $\frac{1}{2}$	10 $\frac{3}{4}$	" 11 $\frac{1}{2}$	10 $\frac{1}{4}$	" 11	11	" 11	0 10 $\frac{3}{4}$	0 9 $\frac{3}{4}$

<sup>1</sup> The prices of English wool have been calculated from the list given weekly in the *Economist* newspaper.

**TABLE V.—NUMBER OF HORSES, CATTLE, SHEEP, AND PIGS IN THE UNDERMENTIONED COUNTRIES, FOR EACH OF THE YEARS INDICATED.**  
*[From the Agricultural Returns.]*

Countries	Years	Horses	Cattle	Sheep and lambs	Pigs
		No.	No.	No.	No.
United Kingdom . . . . .	1888	1,936,702	10,268,600	28,938,716	3,815,643
	1889	1,945,386	10,272,765	29,484,774	3,905,865
	1890	1,964,911	10,789,858	31,667,195	4,362,040
Australasia . . . . .	1887	1,438,551	8,873,574	97,239,986	1,100,478
	1888	1,485,923	9,136,178	96,134,041	1,075,316
	1889	1,543,641	9,462,316	101,274,080	1,041,359
Canada <sup>1</sup> . . . . .	1887	605,276	2,049,945	1,408,701	868,530
	1888	596,218	1,928,638	1,349,044	819,079
	1889	664,541	2,040,108	1,375,521	887,126
Cape Colony . . . . .	1888	266,120	1,292,039	13,177,285	142,479
	1889	295,370	1,502,845	13,953,445	159,835
Natal . . . . .	1886	50,012	629,725	676,437	32,927
	1887	51,326	611,794	484,288	46,306
	1888	49,548	655,932	609,805	45,569
Austria . . . . .	1869	1,384,623	7,421,915	5,026,392	2,551,973
	1880	1,463,282	8,584,077	3,841,340	2,721,541
Hungary . . . . .	1870	2,158,819	5,279,193	15,076,997	4,443,279
	1880	2,078,528	5,311,378	9,838,133	4,160,127
	1884	1,748,859	4,879,038	10,594,831	4,803,639
Belgium . . . . .	1866	263,163	1,242,445	586,097	632,301
	1880	271,974	1,382,815	365,400	646,375
Denmark . . . . .	1876	352,262	1,348,321	1,719,249	503,667
	1881	347,561	1,470,078	1,548,613	527,417
	1888	373,533	1,459,527	1,225,196	770,785
France . . . . .	1886	2,938,489	13,275,021	22,616,547	5,774,924
	1887	2,908,527	13,395,259	22,880,190	5,978,916
	1888	2,891,919	13,377,368	22,630,620	5,846,578
Germany . . . . .	1873	3,352,231	15,776,702	24,999,406	7,124,088
	1883	3,522,545	15,786,764	19,189,715	9,206,195
Holland . . . . .	1886	272,700	1,530,800	802,700	458,200
	1887	274,300	1,525,600	804,300	490,254
Italy . . . . .	1875	657,544	3,489,125	6,977,104	1,553,582
	1881	660,123	4,783,232	8,596,108	1,163,916
Norway . . . . .	1865	149,167	953,036	1,705,394	96,166
	1875	151,903	1,016,617	1,686,306	101,020
Russia in Europe (Exclusive of Poland) . . . . .	1882	20,015,659	23,845,104	47,508,966	9,207,666
	1883	17,880,792	23,628,031	46,724,736	9,361,980
	1888	19,663,336	24,609,264	44,465,454	9,242,997
Sweden . . . . .	1886	484,885	2,381,467	1,443,676	548,210
	1887	481,257	2,330,706	1,377,685	571,114
	1888	482,096	2,349,098	1,349,807	610,469
United States of America . . . . .	1887	13,172,936	49,234,777	43,544,755	44,346,525
	1888	13,663,294	50,331,042	42,599,079	50,301,592
	1889	14,213,837	52,801,907	44,336,072	51,602,780

<sup>1</sup> The figures given for Canada in 1887 relate to the Provinces of Ontario, Manitoba, and the North-West Territories. In 1888 the numbers for Ontario only are shown.

TABLE VI.—ESTIMATED TOTAL PRODUCE AND YIELD PER ACRE OF THE  
AND NUMBER OF HORSES, CATTLE, SHEEP, AND PIGS, IN

[From the Agricultural Returns and

Crops	England						Wales					
	Acreage, 'thousands' (000) omitted		Produce of crops, 'thou- sands' (000) omitted		Average yield per acre		Acreage, 'thousands' (000) omitted		Produce of crops, 'thou- sands' (000) omitted		Average yield per acre	
	1889	1890	1889	1890	1889	1890	1889	1890	1889	1890	1889	1890
<b>CORN CROPS:—</b>	Acres	Acres	Bush.	Bush.	Bush.	Bush.	Acres	Acres	Bush.	Bush.	Bush.	Bush.
Wheat . . . . .	2,322	2,256	69,336	69,442	29·87	30·79	68	68	1,673	1,713	24·43	24·94
Barley or Bere . . . . .	1,776	1,776	56,037	62,250	31·55	35·06	122	120	3,548	3,622	29·07	30·24
Oats . . . . .	1,624	1,643	68,109	72,104	41·94	43·75	249	241	8,150	8,116	32·73	33·65
Rye . . . . .	59	45	—	—	—	—	1	1	—	—	—	—
Beans . . . . .	304	340	8,693	11,103	28·55	32·63	2	2	47	59	28·92	31·35
Peas . . . . .	222	216	5,840	6,223	26·32	28·70	1	2	31	40	21·16	23·62
<b>TOTAL CORN CROPS .</b>	<b>6,307</b>	<b>6,281</b>	<b>—</b>	<b>—</b>	<b>—</b>	<b>—</b>	<b>443</b>	<b>434</b>	<b>—</b>	<b>—</b>	<b>—</b>	<b>—</b>
<b>GREEN CROPS:—</b>			Tons	Tons	Tons	Tons			Tons	Tons	Tons	Tons
Potatoes . . . . .	385	348	2,337	1,959	6·08	5·62	40	40	238	177	5·95	4·43
Turnips and Swedes . . . . .	1,370	1,303	19,225	19,012	14·03	13·65	72	72	1,683	1,155	14·99	15·91
Mangolds . . . . .	318	323	5,978	5,903	18·79	18·20	7	7	122	126	17·53	17·22
Carrots, Cabbage, Kohl- rabi, and Rape . . . . .	151	161	—	—	—	—	2	3	—	—	—	—
Vetches, &c. . . . .	294	298	—	—	—	—	3	3	—	—	—	—
<b>TOTAL GREEN CROPS</b>	<b>2,519</b>	<b>2,523</b>	<b>—</b>	<b>—</b>	<b>—</b>	<b>—</b>	<b>124</b>	<b>125</b>	<b>—</b>	<b>—</b>	<b>—</b>	<b>—</b>
<b>OTHER CROPS, GRASS, &amp;c.:—</b>			Cwt.	Cwt.	Cwt.	Cwt.						
Clover and artificial grasses and permanent pasture . . . . .	9,420	9,811	—	—	—	—	1,572	1,614	—	—	—	—
Ditto for hay . . . . .	6,168	5,816	9,692	8,183	—	—	695	674	781	737	—	—
Flax . . . . .	2	2	—	—	—	—	—	—	—	—	—	—
Hops . . . . .	58	54	498	284	8·62	5·26	—	—	—	—	—	—
Small Fruit* . . . . .	37	41	—	—	—	—	1	1	—	—	—	—
<b>TOTAL OTHER CROPS .</b>	<b>15,085</b>	<b>15,724</b>	<b>—</b>	<b>—</b>	<b>—</b>	<b>—</b>	<b>2,268</b>	<b>2,289</b>	<b>—</b>	<b>—</b>	<b>—</b>	<b>—</b>
<b>Live Stock</b>		<b>Year 1889</b>		<b>Year 1890</b>		<b>Year 1889</b>		<b>Year 1890</b>		<b>Year 1889</b>		<b>Year 1890</b>
		Actual No.		Actual No.		Actual No.		Actual No.		Actual No.		Actual No.
Horses . . . . .		1,091,011		1,099,557		141,143		143,336				
Cattle . . . . .		4,352,657		4,617,641		666,101		705,115				
Sheep . . . . .		15,839,882		16,811,288		2,840,689		3,069,710				
Pigs . . . . .		2,118,385		2,355,760		240,741		258,175				

NOTE.—The produce of the Corn Crops for Ireland, which was originally given in weight, has been converted into the bushel of Beans and Peas. \* Turnips only. \* Including Beetroot. \* Gooseberries, strawberries, and



PRINCIPAL CROPS, AND ALSO THE ACREAGE UNDER OTHER CROPS AND GRASS,  
THE UNITED KINGDOM IN THE YEARS 1889 AND 1890.

[the Agricultural Produce Statistics.]

Scotland						Ireland						United Kingdom					
Acreage, thousands' (000) omitted		Produce of crops, 'thousands' (000) omitted		Average yield per acre		Acreage, 'thousands' (000) omitted		Produce of crops, 'thousands' (000) omitted		Average yield per acre		Acreage, 'thousands' (000) omitted		Produce of crops, 'thousands' (000) omitted		Average yield per acre	
1889	1890	1889	1890	1889	1890	1889	1890	1889	1890	1889	1890	1889	1890	1889	1890	1889	1890
Acres	Acres	Bush.	Bush.	Bush.	Bush.	Acres	Acres	Bush.	Bush.	Bush.	Bush.	Acres	Acres	Bush.	Bush.	Bus.	Bus.
59	62	2,194	2,200	36.94	35.49	89	92	2,681	2,639	29.87	28.58	2,539	2,479	75,884	75,994	29.89	30.66
223	216	7,842	8,062	35.09	37.36	186	182	7,277	6,860	39.07	37.60	2,308	2,294	74,704	80,794	32.37	35.23
1,016	1,014	37,182	39,968	36.61	39.43	1,239	1,221	50,637	51,107	40.87	41.86	4,128	4,124	164,078	171,295	39.75	41.54
9	8	—	—	—	—	16	15	—	—	—	—	85	69	—	—	—	—
15	16	509	536	34.10	33.33	4	4	125	162	34.05	43.61	325	362	9,375	11,860	28.87	32.77
1	1	35	31	24.85	25.48	1	1	15	19	22.46	29.30	226	220	5,921	6,313	26.27	28.71
1,323	1,317	—	—	—	—	1,535	1,515	—	—	—	—	9,611	9,548	—	—	—	—
155	142	1,012	676	6.54	4.78	787	781	2,848	1,810	3.62	2.32	1,366	1,310	6,435	4,622	4.71	3.53
478	482	7,789	7,581	16.30	15.72	2,298	2,295	3,910	4,255	13.12	14.40	2,218	2,243	32,007	32,002	14.43	14.27
1	1	19	17	17.21	14.57	44	47	622	663	14.12	14.27	370	378	6,740	6,709	18.21	17.76
9	11	—	—	—	—	52	56	—	—	—	—	216	232	—	—	—	—
14	14	—	—	—	—	38	35	—	—	—	—	351	352	—	—	—	—
657	650	—	—	—	—	1,219	1,214	—	—	—	—	4,521	4,516	—	—	—	—
2,286	2,330	—	—	—	—	9,995	10,211	—	—	—	—	23,330	24,026	—	—	—	—
601	581	958	952	—	—	2,187	2,093	4,854	4,594	—	—	9,675	9,187	16,285	14,466	—	—
—	—	—	—	—	—	114	97	—	—	—	—	116	99	Cwt.	Cwt.	—	Cwt.
—	—	—	—	—	—	—	—	—	—	—	—	58	54	498	284	8.62	5.26
4	4	—	—	—	—	—	—	—	—	—	—	—	—	—	—	—	—
2,891	2,915	—	—	—	—	12,296	12,401	—	—	—	—	33,179	33,366	—	—	—	—

Year 1889		Year 1890		Year 1889		Year 1890		Year 1889		Year 1890	
Actual No.	189,205	Actual No.	189,727	Actual No.	515,188	Actual No.	523,381	Actual No.	1,945,386	Actual No.	1,964,911
1,120,797		1,185,876		4,093,944		4,240,753		10,272,765		10,789,858	
6,951,449		7,361,461		3,789,629		4,323,805		29,484,774		31,667,195	
151,677		159,674		1,380,548		1,570,279		3,905,835		4,362,040	

bushels, at the rate of 60 lb. to the bushel of Wheat; 50 lb. to the bushel of Barley; 39 lb. to the bushel of Oats; and 60 lb. to other small fruit, including what is grown between trees in orchards and also in market gardens.

TABLE VII.—QUANTITIES AND VALUES OF CORN, MEAT, FOOD PRODUCTS, KINGDOM IN THE YEAR 1890, WITH THE

(From Trade and

	Quantities			Values		
	1888	1889	1890	1888	1889	1890
<b>ANIMALS, LIVING (for food):—</b>	No.	No.	No.	£	£	£
Oxen and Bulls . . . . .	287,266	441,811	536,518	5,130,637	8,133,468	9,682,778
Cows . . . . .	49,724	60,366	49,146	634,982	732,385	595,178
Calves . . . . .	40,098	53,044	56,929	146,155	203,454	227,591
TOTAL CATTLE . . . . .	377,088	555,221	642,593	5,911,974	9,069,307	10,505,547
Sheep and Lambs . . . . .	956,210	678,058	358,458	1,740,549	1,195,407	696,312
Swine . . . . .	24,509	25,324	4,036	74,784	95,373	14,474
TOTAL . . . . .	..	..	..	7,727,307	10,360,087	11,216,333
<b>CORN:—</b>	Cwt.	Cwt.	Cwt.			
Wheat . . . . .	57,224,934	58,602,271	60,474,180	24,971,331	22,530,838	23,584,616
Wheat Meal and Flour . . . . .	16,912,773	14,639,201	15,773,336	9,530,800	8,559,563	9,074,290
Barley . . . . .	21,277,477	17,415,943	16,677,988	6,069,190	4,968,947	4,985,406
Oats . . . . .	18,737,436	15,999,060	12,727,186	4,588,712	4,472,598	3,908,497
Peas . . . . .	2,420,847	1,688,512	1,812,488	705,747	553,503	605,099
Beans . . . . .	3,010,144	3,585,473	3,344,918	920,088	1,123,233	993,505
Maize . . . . .	25,338,651	36,203,069	43,437,634	6,881,307	8,580,080	9,863,034
Maize Meal . . . . .	14,846	24,066	57,145	8,046	19,365	30,060
TOTAL . . . . .	144,937,008	148,217,595	154,335,075	50,675,221	50,808,127	53,044,507
<b>MEAT:—</b>						
Beef, Salted . . . . .	226,636	264,542	274,726	349,259	371,580	381,734
„ Fresh . . . . .	837,414	1,379,511	1,854,593	1,920,847	3,015,180	3,923,015
Mutton, Fresh . . . . .	989,085	1,226,669	1,656,410	1,940,979	2,678,621	3,447,776
Bacon . . . . .	2,854,536	3,498,144	3,790,570	6,592,959	7,287,297	6,978,061
Hams . . . . .	728,305	977,606	1,209,446	1,923,936	2,501,484	2,869,115
Pork, Salted (not Hams) . . . . .	214,891	269,587	251,857	359,921	390,266	341,424
„ Fresh . . . . .	242,778	116,846	45,295	556,954	286,139	109,834
Meat, unenumerated— Salted or Fresh . . . . .	56,781	90,982	103,581	120,551	197,017	227,572
Meat preserved otherwise than by Salting . . . . .	542,599	642,857	734,811 <sup>1</sup>	1,377,023	1,632,333	1,946,195 <sup>2</sup>
Rabbits . . . . .	100,872	123,774	143,641	276,562	341,483	398,098
TOTAL . . . . .	6,823,827	8,590,520	10,068,239	15,218,991	18,601,309	20,622,824

<sup>1</sup> Beef, 551,098 cwt.; mutton, 78,409 cwt.; other sorts, 105,304 cwt.<sup>2</sup> Beef, 1,424,419 $\frac{1}{2}$ ; mutton, 181,482 $\frac{1}{2}$ ; other sorts, 340,294 $\frac{1}{2}$ .

AND ARTICLES AFFECTING AGRICULTURE, IMPORTED INTO THE UNITED  
CORRESPONDING FIGURES FOR 1888 AND 1889.

(Navigation Returns.)

	Quantities			Values		
	1888	1889	1890	1888	1889	1890
<b>DAIRY PRODUCE:—</b>	Cwt.	Cwt.	Cwt.	£	£	£
Butter . . . . .	1,663,314	1,927,469	2,027,717	8,902,193	10,243,728	10,598,848
Margarine . . . . .	1,138,174	1,240,760	1,079,996	3,263,826	3,652,722	3,083,731
Cheese . . . . .	1,917,541	1,909,545	2,144,074	4,542,278	4,494,554	4,975,234
TOTAL . . . . .	4,725,029	5,077,774	5,251,787	16,708,297	18,391,004	18,657,813
<b>POULTRY, &amp;C.:—</b>						
Poultry and Game, alive or dead . . . . .	—	—	—	403,197	472,686	497,858
Eggs . . . . .	Gt. Hunds. 9,320,617	Gt. Hunds. 9,416,639	Gt. Hunds. 10,291,246	3,077,109	3,122,813	3,428,802
TOTAL . . . . .	—	—	—	3,480,306	3,595,499	3,926,660
<b>FRUIT, VEGETABLES, &amp;C.:—</b>	Bushels	Bushels	Bushels			
Apples (raw) . . . . .	3,821,946	3,617,997	2,574,957	1,037,084	976,118	786,072
Fruit, unenumerated (raw)	3,039,100	2,189,508	3,584,663	1,387,271	1,149,834	1,806,811
Onions . . . . .	3,479,418	3,862,751	3,871,195	641,256	674,547	724,020
Potatoes . . . . .	2,384,144	1,864,610	1,940,100	802,110	735,999	714,257
Vegetables, unenum- erated (raw) . . . . .	—	—	—	621,771	623,789	773,590
Hops . . . . .	Cwt. 215,927	Cwt. 200,690	Cwt. 188,028	796,404	716,637	877,704
TOTAL . . . . .	—	—	—	5,285,896	4,876,924	5,682,454
<b>OTHER ARTICLES:—</b>	Cwt.	Cwt.	Cwt.			
Lard . . . . .	883,469	1,193,831	1,273,236	1,815,420	2,178,408	2,091,704
Flax . . . . .	1,833,650 Lb.	1,783,189 Lb.	1,800,469 Lb.	2,991,898	3,066,114	2,856,276
Wool, Sheep and Lambs' .	635,936,244	690,396,186	630,236,298	25,897,745	28,393,755	26,945,057
Wood & Timber:	Loads	Loads	Loads			
Hewn . . . . .	1,985,249	2,389,491	2,278,374	4,042,407	5,635,118	5,004,554
Sawn or Split, Planed or Dressed . . . . .	4,336,084	5,318,750	4,778,314	9,638,077	13,142,333	11,092,221
Staves . . . . .	143,872 Tons	170,155 Tons	155,995 Tons	590,112	694,115	689,243
Oil-Seed Cake . . . . .	259,573 Cwt.	256,296 Cwt.	280,616 Cwt.	1,620,634	1,703,521	1,743,279
Seeds: Clover and Grass .	334,432 Tons	296,314 Tons	378,589 Tons	684,185	608,097	758,294
" Cotton . . . . .	255,500 Qrs.	289,413 Qrs.	314,050 Qrs.	1,646,349	1,940,995	1,749,215
" Flax and Linseed . .	2,542,027	2,272,019	1,932,035	4,800,016	4,577,799	3,949,104
" Rape . . . . .	279,615	458,948	230,547	448,254	820,273	416,377
TOTAL . . . . .	—	—	—	54,175,097	62,760,528	57,275,321

TABLE VIII.—NUMBER AND VALUE OF LIVE CATTLE, SHEEP, AND SWINE IMPORTED INTO THE UNITED KINGDOM IN THE UNDERMENTIONED YEARS.

[From Trade and Navigation Returns.]

	Number			Value			
	1888	1889	1890	1888	1889	1890	
Oxen and Bulls	From Denmark . . .	27,385	30,047	21,238	£ 334,451	£ 359,245	£ 245,578
	„ Germany . . .	10,304	—	—	176,347	—	—
	„ Spain . . .	11,484	11,587	8,071	188,614	190,754	132,450
	„ Canada . . .	58,761	82,207	109,610	1,036,269	1,424,731	1,739,718
	„ United States . . .	142,865	291,128	384,198	2,840,911	5,793,366	7,351,981
	„ Other Countries . . .	36,467	23,842	13,401	554,245	365,372	213,051
Total . . .	287,266	441,811	536,518	5,130,837	8,133,468	9,682,778	
Cows	From Denmark . . .	35,439	47,895	32,699	410,867	539,436	357,584
	„ Sweden . . .	3,061	2,887	1,660	34,648	32,409	18,551
	„ Germany . . .	4,239	—	—	66,415	—	—
	„ Canada . . .	2,216	2,237	10,859	40,354	39,342	152,580
	„ United States . . .	630	262	441	12,415	4,285	7,234
	„ Other Countries . . .	4,139	7,085	3,487	70,283	116,913	59,229
Total . . .	49,724	60,366	49,146	634,982	732,385	595,178	
Calves	From Denmark . . .	4,235	10,911	22,021	15,959	39,474	79,308
	„ Holland . . .	35,494	41,214	33,424	128,863	160,282	143,781
	„ Canada . . .	167	144	840	454	249	1,683
	„ United States . . .	—	33	7	—	111	17
	„ Other Countries . . .	202	742	637	879	3,338	2,802
	Total . . .	40,098	53,044	56,929	146,155	203,454	227,591
Sheep and Lambs	From Denmark . . .	94,454	153,362	139,465	134,949	226,163	203,449
	„ Germany . . .	299,589	193,191	—	536,851	318,939	—
	„ Holland . . .	498,458	198,035	119,669	954,268	422,129	319,490
	„ Canada . . .	45,339	55,857	42,640	89,272	111,128	83,656
	„ United States . . .	1,203	18,690	3,904	1,956	36,288	7,900
	„ Other Countries . . .	17,167	58,923	52,780	23,253	80,760	81,817
Total . . .	956,210	678,058	358,458	1,740,549	1,195,407	696,312	
Swine	From Denmark . . .	16,325	19,719	1,420	56,521	79,036	5,671
	„ Holland . . .	8,173	1,675	362	18,230	3,189	1,205
	„ Canada . . .	—	—	—	—	—	—
	„ United States . . .	—	—	1,086	—	—	4,054
	„ Other Countries . . .	11	3,930	1,168	33	13,154	3,544
	Total . . .	24,509	25,324	4,036	74,784	95,373	14,474
Total value of all kinds . . .	. . .	. . .	. . .	7,727,307	10,360,087	11,216,333	

TABLE IX.—QUANTITY AND VALUE OF DEAD MEAT IMPORTED INTO THE UNITED KINGDOM IN THE FOUR YEARS, 1887-90.

[From Trade and Navigation Returns.]

Thousands ("000") omitted.

DEAD MEAT		1887		1888		1889		1890		
		Quantity	Value	Quantity	Value	Quantity	Value	Quantity	Value	
BACON :—	From United States . . .	2,203	4,229	1,865	3,853	2,548	4,810	2,935	4,891	
	„ Other Countries . . .	798	2,101	989	2,540	950	2,477	856	2,087	
	Total . . .	3,001	6,330	2,854	6,393	3,498	7,287	3,791	6,978	
BEEF :—	Salted . . . {	From United States . . .	203	310	213	325	254	352	263	359
		„ Other Countries . . .	15	24	13	24	11	19	12	23
		Total . . .	218	334	226	349	265	371	275	382
Fresh . . . {	From United States . . .	645	1,456	785	1,815	1,270	2,812	1,694	3,630	
	„ Other Countries . . .	13	25	52	106	110	203	161	293	
	Total . . .	658	1,481	837	1,921	1,380	3,015	1,855	3,923	
HAMS :—	From United States . . .	814	2,097	647	1,697	873	2,217	1,094	2,584	
	„ Other Countries . . .	107	293	81	227	104	284	115	285	
	Total . . .	921	2,390	728	1,924	977	2,501	1,209	2,869	
MEAT, Unenumerated :—	Salted or Fresh {	From United States . . .	6	13	3	6	22	48	17	32
		„ Other Countries . . .	41	103	54	114	69	149	87	195
		Total . . .	47	116	57	120	91	197	104	227
Preserved, other- wise than by Salting . . . {	Beef . . . . .	..	..	..	..	..	..	552	1,424	
	Mutton . . . . .	..	..	..	..	..	..	78	182	
	Other Sorts . . . . .	..	..	..	..	..	..	105	340	
Total . . .	519	1,350	543	1,377	643	1,632	735	1,940		
MUTTON, Fresh :—	From Holland . . .	63	152	88	190	78	175	116	275	
	„ Australasia . . .	441	925	543	1,104	613	1,292	897	1,823	
	„ Argentine Republic . . .	251	443	347	628	395	750	435	823	
	„ Other Countries . . .	30	57	11	19	141	362	208	527	
	Total . . .	785	1,577	989	1,941	1,227	2,579	1,656	3,448	
PORK :—	Salted or Fresh (not Hams) . . . {	From United States . . .	192	275	150	238	192	283	205	282
		„ Other Countries . . .	236	498	338	679	194	393	95	169
		Total . . .	428	773	488	917	386	676	300	451
RABBITS :—	From Belgium . . .	110	293	92	250	113	309	129	357	
	„ Other Countries . . .	7	18	9	26	11	32	14	41	
	Total . . .	117	311	101	276	124	341	143	398	
TOTAL OF DEAD MEAT . . .		6,694	14,662	6,823	15,218	8,591	18,601	10,068	20,623	

<sup>1</sup> Not separately enumerated prior to 1890.

TABLE X.—QUANTITIES AND VALUES OF BUTTER, MARGARINE, CHEESE, AND EGGS IMPORTED INTO THE UNITED KINGDOM IN EACH YEAR FROM 1888 TO 1890 INCLUSIVE.

[From Trade and Navigation Returns.]

	QUANTITIES			VALUES		
	1888	1889	1890	1888	1889	1890
<b>BUTTER</b>						
	cwt.	cwt.	cwt.	£	£	£
From Sweden . . . .	205,847	212,141	224,235	1,128,939	1,141,218	1,175,722
„ Denmark . . . .	604,512	677,491	824,749	3,335,064	3,743,576	4,422,257
„ Germany . . . .	160,915	111,027	104,450	813,198	588,660	544,271
„ Holland . . . .	155,020	151,073	156,069	784,523	767,457	792,786
„ France . . . .	439,993	566,524	525,105	2,378,835	3,073,473	2,847,144
„ Canada . . . .	9,173	22,634	15,155	40,797	95,167	60,739
„ United States . . . .	23,207	110,187	84,553	93,243	448,825	322,385
„ Other Countries . . . .	70,647	76,392	93,401	327,594	385,352	433,544
Total . . . .	1,669,314	1,927,469	2,027,717	8,902,193	10,243,728	10,598,848
<b>MARGARINE</b>						
	cwt.	cwt.	cwt.	£	£	£
From Norway . . . .	7,784	11,051	15,084	25,045	33,399	45,578
„ Holland . . . .	1,048,401	1,137,094	1,001,968	2,951,522	3,280,628	2,804,675
„ Belgium . . . .	6,676	10,527	1,684	18,130	30,269	4,454
„ Other Countries . . . .	80,313	82,088	61,260	269,129	308,426	229,024
Total . . . .	1,138,174	1,240,760	1,079,996	3,263,826	3,652,722	3,083,731
<b>CHEESE</b>						
	cwt.	cwt.	cwt.	£	£	£
From Holland . . . .	328,801	327,384	292,215	822,498	807,037	723,105
„ France . . . .	29,304	32,941	40,364	92,428	106,057	127,832
„ Canada . . . .	667,461	675,900	837,890	1,523,833	1,565,526	1,914,232
„ United States . . . .	812,130	827,626	919,408	1,905,776	1,899,864	2,081,546
„ Other Countries . . . .	79,545	45,694	54,197	197,743	116,070	128,519
Total . . . .	1,917,541	1,909,545	2,144,074	4,542,278	4,494,554	4,975,234
<b>EGGS</b>						
	great hundreds	great hundreds	great hundreds	£	£	£
From Germany . . . .	3,707,091	2,998,865	2,915,491	1,146,739	893,902	868,655
„ Belgium . . . .	1,582,929	1,817,353	1,927,477	490,011	565,057	585,032
„ France . . . .	2,692,057	2,950,566	3,089,255	1,053,309	1,181,335	1,270,092
„ Other Countries . . . .	1,338,540	1,649,855	2,359,023	387,050	482,519	705,023
Total . . . .	9,320,617	9,416,639	10,291,246	3,077,109	3,122,813	3,428,802

TABLE XI.—VALUE OF CORN IMPORTED INTO THE UNITED KINGDOM IN EACH OF THE SEVEN YEARS 1881-90.

[From Trade and Navigation Returns.]

	1884	1885	1886	1887	1888	1889	1890
	£	£	£	£	£	£	£
Wheat . . . . .	19,825,021	24,066,013	17,888,155	21,335,902	21,971,331	22,530,838	23,584,616
Wheat Flour . . . . .	10,166,010	9,651,508	8,254,407	10,020,433	9,530,809	8,559,563	9,074,290
Barley . . . . .	29,991,031	33,717,521	26,142,562	31,356,335	31,502,131	31,090,401	32,658,906
Oats . . . . .	4,228,722	4,528,823	3,968,437	3,769,272	6,069,190	4,968,947	4,965,406
Maize . . . . .	4,195,514	4,252,135	3,974,434	3,489,818	4,588,712	4,472,598	3,908,197
Maize Meal . . . . .	7,303,099	8,473,863	7,614,113	7,535,946	6,861,307	8,580,080	9,863,034
Beans and Peas . . . . .	23,970	18,811	12,899	4,934	8,046	19,365	30,060
Beans and Peas . . . . .	1,820,366	1,758,105	1,512,985	1,662,992	1,625,835	1,676,736	1,598,604
Total of Corn	47,562,702	52,740,258	43,225,430	47,819,297	50,675,221	50,808,127	53,041,507

TABLE XII.—QUANTITIES OF WHEAT, WHEAT MEAL, AND FLOUR IMPORTED INTO THE UNITED KINGDOM IN THE FIVE YEARS 1886-90; ALSO THE COUNTRIES FROM WHICH THEY WERE OBTAINED.

[From Trade and Navigation Returns.]

(Thousands ("000") omitted.)

	1886	1887	1888	1889	1890
Wheat from—	Cwt.	Cwt.	Cwt.	Cwt.	Cwt.
Russia . . . . .	3,710	5,523	21,369	21,322	19,389
Germany . . . . .	1,318	1,552	3,265	2,539	1,101
France . . . . .	3	71	20	127	$\frac{1}{2}$
Turkey . . . . .	249	2	182	667	900
Roumania . . . . .	290	585	1,419	2,862	4,654
Egypt . . . . .	41	198	730	325	425
United States . . . . .	24,621	30,505	14,647	17,016	17,201
Chili . . . . .	1,702	2,206	1,486	573	24
British India . . . . .	11,029	8,509	8,189	9,217	9,112
Australasia . . . . .	739	1,347	2,316	1,406	3,058
British North America . . . . .	3,081	3,965	1,089	1,168	1,128
Other Countries . . . . .	622	1,322	2,513	1,380	3,482
Total Wheat . . . . .	47,405	55,785	57,225	58,602	60,474 $\frac{1}{2}$
Wheat Meal and Flour from—					
Germany . . . . .	817	589	1,109	1,155	895
France . . . . .	115	98	102	91	103
Austrian Territories . . . . .	1,362	1,391	1,946	1,838	1,370
United States . . . . .	11,473	14,873	12,557	10,068	12,026
British North America . . . . .	770	959	785	1,169	933
Other Countries . . . . .	202	147	414	378	446
Total Wheat Meal and Flour . . . . .	14,739	18,057	16,913	14,699	15,773

TABLE XIII.—NUMBER OF HORSES, AND THEIR DECLARED VALUE, IMPORTED INTO, AND EXPORTED FROM, THE UNITED KINGDOM, IN EACH OF THE UNDERMENTIONED YEARS.

[From Agricultural Returns and Trade and Navigation Returns.]

Year	IMPORTED		Year	EXPORTED	
	Number	Value		Number	Value
1886	11,026	£ 189,901	1886	7,326	£ 409,045
1887	11,641	197,679	1887	9,463	547,396
1888	11,505	192,624	1888	12,880	848,311
1889	13,832	277,388	1889	14,266	984,611
1890	19,404 <sup>1</sup>	336,496	1890	12,922	629,187

<sup>1</sup> NOTE.—The countries from which horses were imported in 1890 were as follows:—Germany, 12,600; Denmark, 2,607; Holland, 1,575; France, 783; Belgium, 499; United States of America, 364; Canada, 225; and 751 from other countries.

TABLE XIV.—QUANTITIES OF CERTAIN ARTICLES OF FOREIGN AND COLONIAL PRODUCTION IMPORTED INTO THE UNITED KINGDOM IN THE YEARS 1887-90

[From Trade and Navigation Returns.]

	1887	1888	1889	1890
Bones (whether burnt or not) } tons }	51,882	65,651	62,855	69,949
Cotton, Raw . . . . . cwt.	15,903,117	15,246,408	17,159,316	16,011,350
Guano . . . . . tons	21,251	25,052	26,804	28,005
Hemp . . . . . cwt.	1,472,857	1,822,065	1,973,210	1,890,367
Hides untanned: Dry . . . . . "	627,132	585,254	575,158	455,098
Wet . . . . . "	523,393	576,176	647,250	584,948
Petroleum . . . . . gallons	77,458,062	94,177,807	102,647,478	104,809,146
Flax-seed and Linseed . . . . . qrs.	2,341,175	2,542,027	2,272,019	1,932,035



JOURNAL  
OF THE  
ROYAL AGRICULTURAL SOCIETY  
OF ENGLAND.

---

METHODS OF PREVENTING AND  
CHECKING THE ATTACKS OF  
INSECTS AND FUNGI.

No one can deny that the disorders of cultivated plants have greatly increased both in numbers and intensity, even within the recollection of middle-aged cultivators. This not only applies to Great Britain but also to every country under the sun. The crops on the recently cleared land in Australasian countries are as subject to insects and mildews as those in English fields, which have been tilled from immemorial times. Under the fierce rays of the Indian sun myriads of beetles, caterpillars, and flies, with fungi of divers kinds, frustrate the labours of the planters. In Northern latitudes, where the soil is fast bound by frost for more than half the year, all sorts and conditions of insects appear to vex the crops of corn, herbs, and fruit as soon as the ice and snow have vanished. Rusts, blights, and moulds are just as rife there as under tropical skies or in temperate climes. It will be found, for example, that the Codlin moth is as destructive in the apple orchards of Canada, the United States, and Australasia as in those of England, and that the wheat-fields in Manitoba, Minnesota, and New South Wales are becoming as subject to rust (*Ustilago segetum*) as those in the British Isles.

The interchange of seeds, fruits, plants, roots, and cuttings between all the countries of the world has tended to spread many

of the enemies and parasites peculiar to crops. In this way the appearance of new insects and fungi in countries previously free from them is easily accounted for, but it is difficult to explain the reason of the exceeding increase of some of the pests of certain crops within the last half century, and the consequent serious injury occasioned by them. For instance, aphides have come regularly upon the hop plants during the last few seasons, and would have caused utter destruction if prompt measures had not been taken against them. Within the last ten years the caterpillars of the winter-moth have become chronic pests in many of the apple-producing districts of England, having been until then the most occasional visitors in comparatively rare places.

With regard to fungi, their development in the form of mildews, moulds, blights, and rusts is even more remarkable. Fifty years ago the potato disease caused by the fungus *Phytophthora infestans* was unknown in this country, and the vines in France and Germany were free from the *Oidium Tuckeri*, which has caused such great losses in all their vineyards. Since 1878 another mildew (*Peronospora viticola*) has sorely plagued European wine-producers. It was first noticed in France in the Charentes, and spread rapidly. The hop mildew (*Podosphæra castagnei*), though known in Kent before the curious and general invasion of mildews in 1843, has since then assumed a far more virulent and chronic nature, and has extended its attack to all the hop-growing counties. Since 1875 a mildew (*Hemileia vastatrix*) has much troubled the coffee-planters in Ceylon, and within the last few years a mildew (*Peziza Willkommii*) has seriously affected larches in English and Scotch woods and forests. The apple and pear scabs (*Fusicladium dendriticum* and *Fusicladium pyrinum*) were not observed in Great Britain until after 1844. In some seasons since that date apples and pears have been greatly disfigured by the blotches, or black spots, upon them produced by these fungi. The apple scab (*Fusicladium dendriticum*) was first noticed in Canada in 1882; also in Illinois, Wisconsin, and other American States where apples are cultivated. It prevails also in the apple orchards of South Australia, where it was first seen in 1865 or 1866.

Among the most notable and calamitous visitations of insects of modern date, that of the *Phylloxera vastatrix*, or vine louse, in the French vineyards stands prominent in respect of the injury occasioned and the enormous money losses sustained. It is estimated that from 1875 to 1887 the total loss to France amounted to more than 400,000,000*l.*<sup>1</sup> These figures are based

<sup>1</sup> *Les Insectes de la Vigne.* Par Valéry Mayet (1890).

upon the report of the French Director of Agriculture, from which it is also seen that more than 3,000,000 acres, or half of the vineyards of France, were entirely destroyed by this insect. The rest of the vineyards were saved from destruction by the persistent use of most expensive remedies and methods of prevention, which have now to be constantly employed; these, and the substitution of American vines—supposed to be phylloxera proof—for the indigenous varieties, have succeeded in restoring comparative prosperity to the French cultivators of the vine.

The tiny flea-beetle known as the “fly” literally devours the turnip crop in some seasons, causing pecuniary loss that can hardly be estimated. In 1881 the attack of this beetle was very general and disastrous in England and Scotland. Miss Ormerod, in her elaborate report upon an inquiry made for the Seeds and Plant Diseases Committee of the Royal Agricultural Society, considers that the direct loss in twenty-two English and eleven Scotch counties was more than half a million of money, merely for seed, sowing, and resowing, with the necessary cultivation. The indirect loss from the failure of food for stock in these circumstances can hardly be estimated, but it must have been enormous. In most dry seasons this turnip beetle is immensely destructive in parts of the country.

The hop aphid has frequently reduced the hop crop from its estimated annual average of seven cwt. per acre to one and a half or two cwt. per acre, entailing the loss of close upon a million sterling.<sup>1</sup> But in these later days science and energy have triumphed over the enemy, so that a “blight” in hops, with its ruinous consequences, may be averted if the proper measures are taken.

Among the latest calamities that have befallen English producers through insect agency is the wholesale onslaught made upon fruit-trees by innumerable caterpillars of various moths, so that in several fruit-growing counties hundreds of acres of apple, plum, and damson trees have been stripped of leaves, blossoms, and fruit in the last three or four years, and the crops of red currants and raspberries have been nipped in the bud. Against the attacks upon fruit trees the most efficacious remedy has so far proved to be syringing or spraying the trees with “arsenites,” as Paris Green and London Purple, which are extensively used in the United States for severe attacks of insects.

The sawfly (*Nematus ribesii*), or rather its larva, frequently

---

<sup>1</sup> This aphid is termed by E. J. Lance, in his work entitled *The Hop Farmer*, “This blighter, this barometer of poverty!”

spoils the gooseberry and currant crops in plantations and gardens. Caterpillars of a moth known as *Anisopteryx Æscularia* have lately taken to eat the foliage of filbert and cob-nut trees in Kent, and cause much loss to gooseberry growers, by eating the leaves and young fruit.<sup>1</sup> The mustard beetle (*Phædon betulæ*) has much troubled the mustard-seed growers in Cambridgeshire and Lincolnshire since 1884.

There are many other insects more or less vexatious to British cultivators that might be enumerated. Enough has, however, been adduced to show that crops of all kinds are exposed to the most grave dangers from this cause, against which it is most essential that instant and constant watchfulness should be observed.

The same remarks apply to fungoid disorders, even more dangerous and insidious, whose infection can be transmitted by the breezes from field to field, even from country to country, by means of spores, or seeds, that cannot be distinguished without a microscope. Their infection may also be conveyed in plants, seeds, and tubers from one end of the world to the other.

Glancing rapidly at the chief crop-destroying fungi, the potato fungus (*Phytophthora infestans*), immeasurably the most formidable, must naturally be first mentioned. The terrible consequences of its ravages in Ireland are historical. Until lately no rational or satisfactory remedy was propounded for it. It is now believed that sulphate of copper is a valuable remedy for this disease, from experiments that have been made in the past three years in France, Belgium, and the United States. These experiments will be described later on in dealing with various substances that have been found useful against noxious insects and fungi, together with the machines for applying them.

The hop mildew (*Podosphaera castagnei*) ravaged the English gardens unchecked until about twenty-five years ago, when the planters, hearing reports concerning the beneficial use of powdered sulphur against the vine mildew in France, tried this remedy upon the hop plants. Though its action is very uncertain, depending in a great degree upon the weather, there has been a large diminution in the injuries caused by the fungus since the employment of sulphur.

Market gardeners have found the onion mildew (*Peronospora Schleideniana*) most troublesome latterly, affecting both the onions planted for seed as well as those sown for pulling for

---

<sup>1</sup> Some gooseberries were sent me from Cambridge lately which had been half eaten by these caterpillars.

market purposes. At present no important attempts have been made to stay the advances of this fungus; applications of sulphate of copper have been strongly recommended,<sup>1</sup> but no records of experiments made with this have as yet been received. This onion disease is very rife in the Canary Isles and in Bermuda, where onion culture is one of the principal industries. Mr. Shipley, in a report upon this disorder in Bermuda, states that a mixture of freshly burnt quicklime and sulphur has been applied with much advantage, and that solutions of sulphate of iron kill the fungus without injuring the onion plants.<sup>2</sup>

Incalculable losses were sustained by the coffee-planters in Ceylon through the fungus *Hemileia vastatrix* before mentioned. This appeared suddenly about the year 1876. Mr. Marshall Ward, in his report upon this to the Ceylon Government in 1881, proved beyond doubt that the disorder was communicated by the spores of the fungus conveyed by the wind. He placed strips of glass covered with glycerine at some distance from infected coffee plants, and found spores of the fungus imbedded in the glycerine, which proved that they were carried by the air. Many other experiments confirmed the conclusion that the wind conveyed the spores over considerable distances. Innumerable spores in all stages of freshness and decay were observed in the meshes of some canvas exposed among the coffee plants for several months.<sup>3</sup> Mr. Marshall Ward believed that the intervention of forest-land, which prevented the spread of the spores by the wind, had preserved certain coffee plantations from infection.

Among other fungi injurious to crops are the "smut" or "brand" of wheat (*Ustilago segetum*) and "bunt" (*Tilletia caries*), which are checked by steeping the seed wheat in sulphate of copper solutions. Rust (*Puccinia graminis*), very prevalent in some seasons, is difficult to combat, and but little has been attempted in this country in order to prevent it. In Australia it is becoming most destructive, and has, it is said, already caused a loss of 2,500,000*l.* An Intercolonial Conference upon this serious affection of the wheat crop met at Melbourne in March 1890, and recommended each of the Australian Governments to institute experiments in various directions.

---

<sup>1</sup> *Third Annual Report of the Agricultural Adviser to the Board of Agriculture* (1890).

<sup>2</sup> *Report by Mr. A. Shipley on the Onion Disease in the Bermudas.* Kew Bulletin of Miscellaneous Information. October, 1888.

<sup>3</sup> *Report on the Coffee-leaf Disease.* By H. Marshall Ward, Cryptogamist to the Ceylon Government (1881).

For instance:—

- a. On the effect as regards rust of manuring.
- b. The effect of applying lime, ferrous sulphate, and salt to the soil.
- c. The effect of applying to the rusted crops, by means of the Straw-sonizer and otherwise, solutions of sulphate of iron, sulphate of copper, &c.
- d. Efficacy of burning all straw, weeds, and other plants in the infected field, and of using other disinfected agencies with the view of destroying spores.
- e. The relative values of different varieties of wheat.
- f. The effect as regards rust of different times and modes of sowing.
- g. Investigations regarding plants that act as intermediary hosts,<sup>1</sup> and regarding all plants that are affected by rust in the different colonies.

For the fungus causing scab on apples (*Fusicladium dendriticum*) no remedies are yet used in England. In the United States and Canada most satisfactory results have been obtained from spraying the trees with carbonate of copper and ammonia—three ounces of carbonate of copper and one quart of ammonia to 28 gallons of water—also by using “eau céleste,” which is made by dissolving in hot water 2 lb. of sulphate of copper and 2½ lb. of carbonate of soda in separate vessels. These are then mixed together, 1½ pints of ammonia are added, and the whole diluted with 32 gallons of water. It is stated that this latter mixture gave the best results, and the conclusion arrived at from a series of experiments in localities where scab prevailed was that either of the copper mixtures added from 25 to 50 per cent. to the value of the crop, at a cost of not more than 2s. to 2s. 3d. for an average-sized tree. The greater number of the fruit-growers in Great Britain do not know the origin of scab upon apple and pear leaves and fruit, and have no idea that any special treatment will stay it or prevent its appearance, and they would probably smile at the suggestion that solutions of sulphate of copper would effect these desirable results. These affections have not as yet been very serious in this country, but as they will probably increase, like other fungoid diseases, attention will be fixed upon them, and there will be loud outcries for remedial measures.

Many other instances could be adduced of the increase of insects and fungi destructive to crops in this and other lands, but enough has been put forward to show how great and alarming it has been. At the same time the knowledge of economic entomology and mycology has naturally advanced, and there are now numerous skilled workers in many countries

---

<sup>1</sup> As the barberry-tree (*Berberis vulgaris*) in Great Britain.

diffusing information as to the life histories and habits of these enemies, and means to lessen and to hinder their dangerous action. In our own country there is first and foremost Miss Ormerod, the Consulting Entomologist of the Royal Agricultural Society, who has devoted her life to explain to cultivators the mischief done by certain insects, and how to destroy them or to diminish their evil effects. Professor Riley has done the same in the United States with persistent energy and splendid ability. There are a crowd of others in America working on the same lines with the utmost intelligence. Among these may be mentioned Professors Lintner and Comstock, Dr. Packard and Mr. Hubbard. All these are engaged in finding out modes of preserving crops from insect ravages. Their works and reports teem with their successes, and consequent gain to farmers, fruit-growers, and gardeners. By their science and practical skill the invasions of locusts from the Rocky Mountains into the corn-covered plains below have been wonderfully minimised. Through their sagacity the Colorado beetle has been baffled in its work of destroying potato crops by means of poisonous "Paris Green" judiciously distributed upon the leaves; while the Codlin moth, the insidious destroyer of apples, quails equally under well-directed sprayings of this and its kindred "arsenite," London Purple." <sup>1</sup>

Perhaps among the many brilliant achievements of the generals of the United States entomological army the complete victory of Professor Riley over the fluted scale (*Icerya Purchasi*) in the orange and lemon groves of California fitly bears the palm. These scale insects in 1886 and 1887 were fast destroying all the trees of the citron tribe in California, when Professor Riley had the happy thought to send a qualified person to Australia to collect and bring over quantities of a beetle (*Vedalia cardinalis*) known to feed upon the scale insects there. In an extremely short space of time this beetle, which is much like the ladybird (*Coccinella septem-punctata*, Bête de bon Dieu), that clears off the aphides from hop plants and roses, had freed the greater part of the orange and lemon trees from their foes. As Mr. Henry, another American entomologist, remarked, this was the "best stroke ever made by the Agricultural Department at Washington. The distress was very great indeed, and, had no remedy been found, the scale would probably have destroyed the

---

<sup>1</sup> All this is recorded in Professor Riley's remarkable *Missouri Reports*, and his subsequent *Reports to the United States Department of Agriculture*; also in Dr. Lintner's *Annual Reports* as Entomologist to the State of New York, and in the valuable *Reports of the United States Entomological Commission*, by Professor Riley and Dr. Packard.

citron industry of the State, for its spreading to every grove would only have been a question of time.”<sup>1</sup>

Not less important and valuable are the achievements of French *savants* in their warfare against the phylloxera, the scourge of vineyards, whose calamitous action has been previously described. By means of submersion of the land in the plains that could be irrigated, by the application of bisulphide of carbon and sulpho-carbonate of potassium, and by replanting with American vine stocks proof against these insects, the plague has almost been stayed. It is calculated that at least one million acres of vineyard have been replanted with American stocks. Until better and cheaper modes of using bisulphide of carbon and sulpho-carbonate of potassium were devised the cost was very great. The bisulphide is put into the ground in two or three holes close round the roots of each vine with a kind of hand-pump (*pal*) terminating in a tube with a short point having an orifice near its end. This is thrust into the earth, and the liquid is forced into the hole by pressure from the pump. Sulpho-carbonate of potassium is conveyed through main pipes laid in the ground in the vineyards, communicating with a second system of pipes of much smaller diameter, from which there is a third system of small india-rubber or gutta-percha hose with taps to be turned on for the treatment of each stock. By means of a steam-engine the liquid is forced through the systems of pipes. The cost of this is from 3*l.* to 6*l.* per acre. Before this improved method was introduced the cost was from 20*l.* to 30*l.* per acre, which was prohibitive to all but wealthy proprietors.<sup>2</sup> By these and other means, carried out with vigour and persistency, the phylloxera will be soon stamped out from the French vineyards. “Nowhere,” says Professor Riley, “has the combat been carried on more energetically than in France, originally the most sorely stricken country, and nowhere has so much success been achieved against phylloxera attack.”<sup>3</sup>

The same may be said with regard to the mildews which have plagued the French vineyards, the *Oidium Tuckeri* and its more dangerous congener, *Peronospora viticola*. Constant applications of powdered sulphur keep the former of these in subjection in ordinary climatic conditions, if they are made regularly at certain defined intervals. Curiously, sulphur has no effect, or comparatively no effect, upon the *Peronospora viticola*. Sulphate of copper is employed with wonderful results against the latter fungus. It was the custom to

<sup>1</sup> *Insect Life*. Edited by C. V. Riley. Washington, 1889-90.

<sup>2</sup> *Les Insectes de la Vigne*. Par Valéry Mayet. 1890.

<sup>3</sup> *Insect Life*. Edited by C. V. Riley. Washington, 1889-90.



sprinkle the grapes by the roadsides with dust mixed with verdigris to choke off marauders; after a time sulphate of copper, being cheaper, was used for this purpose. When the *Peronospora viticola* appeared in the country, in 1878, it was remarked that its effect upon the vines thus treated was modified, also that the leaves kept normally green.<sup>1</sup> This led to the trial of sulphate of copper as a remedy, which, owing mainly to the energy of MM. Prillieux, Millardet, and Gayon, has been found to be completely satisfactory. In 1886 M. Prillieux reported, at a *séance* of the Société Nationale d'Agriculture de France, that "the numerous experiments made this year have demonstrated beyond doubt the efficacy of salts of copper in combating the *Peronospora* of the vine."<sup>2</sup> At the same *séance* M. Prillieux strongly advised that careful experiments should be made to prove whether this remedy would be efficacious against the potato mildew (*Phytophthora infestans*) causing the potato disease. He stated that two or three experiments were made in 1886, but, as the conditions were not satisfactory, the results could not be accepted as in any way decisive. Upon M. Prillieux's recommendation experiments have been made in various parts of France, among which stands pre-eminently a series carried out by M. Aimé Girard in 1888, 1889, and 1890. These show plainly that sulphate of copper is as effectual against the potato mildew as against the vine mildew. Experiments carried out in Belgium at the State Agricultural School at Gembloux, under the direction of M. Petermann, and those conducted by M. Thienpont at Etichoe in East Flanders,<sup>3</sup> and others under the direction of the Agricultural Society of East Flanders at Ghent,<sup>4</sup> also proved that this mildew yields to treatment with salts of copper. In America, trials in this direction undertaken in 1889 were satisfactory, and it is learnt from an agricultural journal published at Cape Town, Africa, that "several experts have tried solutions of blue vitriol with good results on enfeebled potato crops." The experiments have only lately been conducted; the reports are, however, favourable without exception.<sup>5</sup>

It has been shown by researches made by MM. Millardet,

<sup>1</sup> *Traitement du Mildew par le Mélange de Sulfate de Cuivre et de Chaux.* Par D. Jouet. *Annales de l'Institut Agronomique*, 1886.

<sup>2</sup> *Bulletin des Séances de la Société Nationale d'Agriculture de France.* No. 10. Année 1886.

<sup>3</sup> *Le Traitement de la Maladie de la Pomme de Terre pendant l'année 1890,* par E. Thienpont. Bruxelles.

<sup>4</sup> *Rapport de la Société Agricole de la Flandre Orientale sur l'Etat de l'Agriculture dans la Province pendant l'année 1890.*

<sup>5</sup> *Agricultural Journal.* Published by the Department of Agriculture of the Cape Colony. December, 1890.

Gayon, and Schløesing<sup>1</sup> that the conidia (the minute spores) of the vine mildew cannot germinate in water containing the most infinitesimal quantity of sulphate of copper. This was proved by experiments of the following nature. The conidia of the fungus sown upon leaves that had been treated with weak sulphate of copper solution did not germinate, while conidia sown upon leaves untreated with sulphate of copper germinated perfectly in the rain-drops upon their upper surfaces. It was found that the vine leaves had great power of absorbing the sulphate of copper, as leaves treated upon their upper surfaces with sulphate of copper resisted inoculation by the fungus when conidia were sown upon their under sides, where the disease first manifests itself. Elaborate experiments reported by M. Schløesing show that the copper is retained with the greatest tenacity by the cuticle of the leaves. It is this retention which makes treatment with sulphate of copper solutions so effective as a preventive of fungoid attacks. With regard to the potato fungus, which appears first upon the under surface of the leaves and invades the plant, descending finally to the tubers, the sulphate of copper application has been shown by recent experiments to prevent the fungus from establishing itself upon the plant, just as in the case of the vine disease. It has also been shown that applications made after the fungus had been established stayed the attack and considerably increased the crop, as compared with example plots not treated. At the same time, the leaves of the plants to which sulphate of copper had been applied to cure the disease already present, preserved their greenness and vigour, while untreated plants were dead and prostrate.

The complete *rationale* of the action of sulphate of copper upon plants has yet to be explained. It is expected that the experiments that are being carried out by the Royal Agricultural Society of England in connection with the Board of Agriculture may throw some light upon this point. They will, it is fully believed, establish the fact that this is a preventive of the potato disease, and that in certain stages it will act as a cure for it.

With all these dangers besetting the crops of the field, the orchard, and the garden it is not unnatural to find a desire on the part of cultivators to be posted up in the life histories of destructive insects and fungi, and especially to be shown ways and means of averting their evil consequences. Miss Ormerod's most valuable reports, and those issued by the Agricultural Depart-

<sup>1</sup> *Recherches nouvelles sur l'action que les composés cuivreux exercent sur le développement du Peronospora de la Vigne. Note de MM. Millardet et Gayon, présentée par M. Schløesing. Comptes-rendus des Séances de l'Académie des Sciences, 1887.*

ment and its successor the Board of Agriculture, have plainly set forth details of the chief crop pests, together with the best means of preventing or mitigating their evil effects. It is, however, considered desirable that a summary should be given of the remedies suggested for the principal insect and fungoid enemies, and the best formulæ for their preparation, founded upon practical experience of their use; also that descriptions should be furnished of the machines and engines that have been proved to be useful in distributing the various prescribed substances upon plants and trees in the most regular and economical fashion. These prescriptions and the apparatus for employing them have been brought down to date. They are not yet by any means satisfactory or sufficient either from a scientific or a practical point of view. The science and practice of the treatment of plant diseases are still in their infancy, the subject having until lately been held to be of comparatively small moment and interest.

Foreign modes of dealing with insects and fungi are also noted here as being in many respects in advance of those in this country, because the losses from these causes have been of a far more serious nature.

For convenience the subject is presented under four heads, viz.:—*Corn Crops; Root and Vegetable Crops; Fruit Crops; Hops*;—under each of which the insecticides and fungicides found useful to combat some of the disorders peculiar to the respective crops are defined, and the best systems of applying them are indicated.

#### CORN, GRASS, AND CLOVER CROPS.

Unfortunately, many of the insects and fungi destructive to corn crops, from the nature and time of their attack, are not amenable to what may be termed heroic treatment, or direct applications of preventives and remedies. For illustration, the Hessian fly (*Cecidomyia destructor*), when once upon the wheat and barley plants, cannot be reached. In like manner the corn sawfly (*Cephus pygmaeus*), the ribbon-footed corn fly (*Chlorops taeniopus*), the wheat bulb fly<sup>1</sup> (*Hylemyia coarctata*), the wheat midge (*Cecidomyia tritici*), and the corn thrips (*Thrips cerealium*), when established, must be left to work their needs of mischief. The same applies to fungi, as the smut (*Ustilago segetum*), and the rust (*Uredo graminis*), against which nothing has been attempted in this country when they are upon the corn plants,

<sup>1</sup> This has caused considerable harm this season in several parts of the country, notably in Essex, Lincoln, and Hertford. Its injury appears to increase.

although it may be found before long that sulphate of copper, applied to the plants when young, will prevent the appearance of these insidious parasites. There are indirect means of preventing the appearance of the above-cited insects and fungi given in the reports already mentioned.

Wireworms, the grubs of the click beetle (*Elatér lineatus*), most troublesome ravagers of corn and other crops, can be hindered in their destructive progress by dressings of gas-lime, at the rate of 10 cwt. per acre ploughed in before a crop is taken, especially in the case of clover leys and broken-up grass land. Top dressings put on the crops in the early spring, consisting of soot, from 20 to 40 bushels per acre, or guano, from 1½ to 3 cwt. per acre, or nitrate of soda, 1 to 2 cwt. per acre, have been found valuable, acting as plant stimulants, as well as by keeping the insects from the plants. Salt put on at the rate of from 4 to 6 cwt. per acre is also useful as tending to make the neighbourhood of the plants unpleasant. Rape dust broadcasted at the rate of 4 to 8 cwt. per acre attracts wireworms to it, as they are very fond of it, and it thus gives the plants a chance of growing away from them, at the same time acting as a forcing stimulant. After all these applications the land should be well rolled with a Crosskill roller.

In some seasons the corn aphid or plant-louse (*Aphis granaria*) causes much harm, first by exhausting the juices of the corn plants—wheat, barley, and oats—and later on by getting into the ears and doing exceeding mischief. When it is seen that these aphides are on the corn plants in numbers it would be well to apply a wash of soft soap and quassia in the proportion of 7 lb. of soap to an infusion made from 6 or 7 lb. of quassia chips to 100 gallons of water.<sup>1</sup> This should be put on with the Strawsonizer, before the corn plants get too high. Or, paraffin solution might be used, made of 3 quarts of paraffin to 100 gallons of water, with 4 or 5 lb. of soft soap; or paraffin pure and simple distributed at the rate of from two to three gallons per acre by the same machine. It must be remembered that aphides multiply with incredible rapidity; early dressings may therefore effectually prevent a bad attack.

For oats affected by eelworms (*Tylenchus devastatrix*), which make the bases of the stems swell and the plants unhealthy and unproductive, applications of sulphate of potash at from 1 to 2½ cwt. per acre have been found most useful; and a mixture of

<sup>1</sup> Soft soap has cost about 15s. per cwt., and quassia 11s. per cwt., taking the average of the last five years.

Superphosphate of lime	2 cwt.	} per acre
Sulphate of potash	1 cwt.	
Sulphate of ammonia	1 cwt.	

has been found of benefit.

To eelworms are frequently due the disease of clover known as "sickness." These minute nematodes may be found in quantities in the stem of disordered clover plants, for which a dressing consisting of

Sulphate of potash	3 cwt.	} per acre
Sulphate of ammonia	1 cwt.	

has been found of great service, and another, equally efficacious, was composed as follows:—

Sulphate of iron	1 cwt.	} per acre.
Sulphate of potash	1 cwt.	
Sulphate of ammonia	1 cwt.	

Almost similar remedies to those employed against wireworms may be used for the grubs of the daddy longlegs (*Tipula oleracea*) and its congeners (*Tipula maculosa*, &c.) when they infest corn crops.

All these dressings of manure and preventive substances can be put on by hand, or with ordinary broad-casting machines,



FIG. 1.—The Strawsonizer for powdered application.

or with the Strawsonizer, whose powers of distribution are now generally acknowledged. One great advantage of this distributor is that as little as half a bushel of powdered sub-

stance can be put on per acre, and as small a quantity of liquid as a gallon per acre if desired. In many cases of insect and fungoid attacks upon plants the object in spraying is to spread the obnoxious substance all over the leaves in the form of a mist or dense fog. A very small quantity suffices to make the plants objectionable to insects and fungi.

Fig. 1 illustrates the machine for distributing powdered manures and dressings, as guano, nitrate of soda, soot, salt, lime, and for sowing corn and seed of all kinds. It is light, being worked by one horse, and will dress or sow at from two to four acres per hour. The machine consists of two driving wheels with several gearing wheels for working up the speed of the

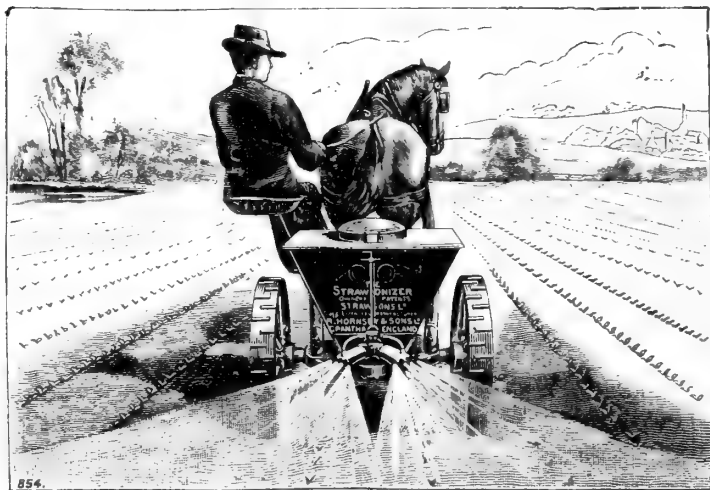

FIG. 2.—The Strawsonizer for liquid application.

small fan within, which revolves at the rate of 300 revolutions per minute. A hopper is used for powders, and a light tank, as will be seen by Fig. 2, when liquids are to be put on.

### ROOT AND VEGETABLE CROPS.

Among the worst enemies of turnip crops, and the first, is the turnip "fly," or flea beetle (*Phyllotreta nemorum*), appearing soon after the seed has germinated, and clearing off every particle of growth as fast as it is made.

A good deal may be done to prevent the attack by cultivation, by getting a fine tilth, sowing plenty of seed, and sowing

upon a stale furrow, and by rolling, &c. The best substances to apply as remedies are :—

Lime, at the rate of from 10 to 20 bushels per acre, put on in the early morning when there is dew on the plants.

Soot, at from 5 to 15 bushels, also put on early.

Mr. Fisher Hobbs's mixture of  $\frac{1}{2}$  bushel of gas lime,  $\frac{1}{2}$  bushel of quicklime, 3 lb. of sulphur, and 5 lb. of soot per acre, well mixed and put on in the early morning.

Finely powdered dry guano is also valuable, at from 1 to 2 cwt. per acre, applied when there is dew.

Pure paraffin oil, at from 1 to 3 gallons per acre, put on at any time ; or, better, paraffin with soft soap and water.

All these applications must be increased in quantity per acre if they are put on by hand. An ordinary broad-casting machine will probably require quite the maximum quantity, or even more, in order to ensure the thorough dressing of each leaf.

Each of these substances can be evenly spread over the plants by means of the Strawsonizer in the minimum quantities stated above, and will be more effectual than large quantities thrown on by hand or with old-fashioned machines. The object is to cover every leaf with fine powder or mist, and make it objectionable to the small beetles and their very minute larvæ. By this machine, from 2 to 4 acres can be treated per hour.

A very useful machine for distributing powdered substances was shown at a recent trial at Sevenoaks. It was adapted by Mr. T. Wood, of Swanley, Kent, being practically a hop sulphurator with the blast directed downwards instead of upwards. It may be used for root and corn crops before they are high, for strawberries, and for bush fruit.<sup>1</sup>

In Kent, Worcester, and Hereford, where hops and fruit are extensively grown, this machine, as shown by Fig. 26, adapted for sulphuring hops as well as for distributing powders for fruit bushes, would be very convenient.

Similar dressings may be adopted for the mustard beetle (*Black Jack*, *Phædon betulae*) to those used for the turnip beetle, though it must be said they are not always efficacious.

For the mustard beetle the following is also serviceable :—

5 lb. of soft soap well dissolved in warm water,  
The extract of 5 lb. of quassia chips, boiled,  
To 100 gallons of water.

This should be put on lightly with the Strawsonizer.

Turnip aphides, cabbage aphides, the turnip sawfly, and other insects of similar habits can be checked materially by soft soap and quassia mixtures. These have been distributed by

<sup>1</sup> See Fig. 26 (p. 255).

means of a large garden engine set upon high wheels, having a pair of hose with jets. This process is tedious, and will now be effected far better by the Strawsonizer.

The comparatively new plague of the mangel wurzel crop, the mangel fly (*Anthomyia beta*), has been affected in an important degree by spraying the plants with a composition of

1 gallon of paraffin oil mixed with 1 gallon of boiling water, in which  $\frac{1}{4}$  lb. of soft soap has been dissolved. This must be well stirred and diluted with at least 10 times its bulk of water.

Or, for the Strawsonizer set to distribute the minimum amount of liquid,

2 gallons of paraffin with 1 or 2 lb. of soft soap, to fix it well on the leaves, would suffice.

Paraffin and soft soap compositions, and quassia and soft soap washes, have been tried with advantage to prevent and check the onion fly (*Anthomyia ceparum*), the celery fly (*Tephritid onopordinis*), and the carrot fly (*Psila rosæ*, all of which are immensely destructive in market gardens and in ordinary gardens. These remedies may be put on with the Strawsonizer



FIG. 3.—The Éclair.

in large holdings, and with garden engines fitted with nozzles like the Riley, the helmet spray, the Climax, and the Stott nozzles (described later on); or with a "Knapsack" machine, of which there are several patterns in use in the French vineyards. The best of these seems to be the Éclair (Fig. 3).

The Éclair is about two feet high and consists of a copper reservoir, or vessel, holding 26 pints, made to fit on to the workman's back, being fastened there with straps

like a knapsack. A rod traverses the lower part of the reservoir inside, being worked by a lever with the workman's



hand. This does not move a piston as in ordinary pumps, but acts upon an india-rubber diaphragm, by whose sucking action the liquid is forced up through the delivery tubes with great force. With the Vermorel or the Riley nozzle the liquid can be delivered in the finest spray, or almost in single jets, and in any direction. For high trees the delivery hose can be lengthened by light canes and directed by a boy. The machine will throw a spray from 20 to 25 feet, and a jet 30 feet high. It weighs about 40 lb. when full. The cost is 35s.<sup>1</sup>



FIG. 1.—The Éclair at work.

Onion crops, a source of much profit to market-gardeners, suffer greatly from the onion mildew (*Peronospora Schleideniana*). Sulphate of copper solutions will prevent this attack if put on onion plants for seed at the end of May, and on onion plants for bulbing just as the bulbs begin to swell.

One of these is a *bouillie bordelaise*, composed of

5 lb. of sulphate of copper (bluestone),  
 2½ lb. of quicklime,  
 22 gallons of water.

One mode of preparing this is to dissolve the sulphate of copper in a wooden vessel in three gallons of boiling water. In another vessel the lime is put with four or five pints of water, and when slaked four gallons of water are added and the whole is well stirred. This is then poured into the tub containing the sulphate of copper, being passed through a sieve to keep back the particles of lime. The whole is well stirred and the rest of the water is added.

Another and a weaker preparation, prescribed by a practical vine cultivator in France, as suitable for the potato mildew, is

3 lb. of sulphate of copper,  
 1 lb. of quicklime,  
 20 gallons of water.

The sulphate of copper should be allowed to dissolve in cold water by hanging it in a coarse bag or basket in a tub. In a separate tank the quicklime is slaked and passed through a sieve

<sup>1</sup> The Éclair is sold in London by Messrs. Clark & Co., Windsor Chambers, 20 Great St. Helens, E.C.

and put into the tub with the sulphate of copper. The whole must be well stirred.

The tomato, a vegetable now cultivated upon a large scale by market-gardeners and ordinary gardeners, is much affected in some seasons by a fungus of the family *Peronosporæ*. Sulphate of copper bouillies have been proved to be efficacious



FIG. 5.—For downward spraying.

against this. These may be put on with the Eclair, or other “Knapsack,” machines.

Sulphate of copper may be used in the form of powder for mildews of various kinds. A good preparation of this consists of

	Parts
Sulphur . . . . .	50
Quicklime . . . . .	3
Sulphate of copper . . . . .	10
Pit-coal dust, very finely crushed . . . . .	37
	100

Another powder, the Skawinski,<sup>1</sup> active against fungoid growths, and used for the vine mildew, is composed of

40 lb. of sulphate of copper,  
6 lb. of quicklime,  
154 lb. of pit-coal dust, very finely crushed.

This may be put on with the soufflet, or bellows (Fig. 6), which constitutes a very useful apparatus for small holders,

<sup>1</sup> The Skawinski powder is obtainable of MM. Skawinski, Lesparre, Médoc, France, at about 9s. 6d. per cwt.

for applying powdered substances in the case of insect and fungoid attacks.<sup>1</sup>

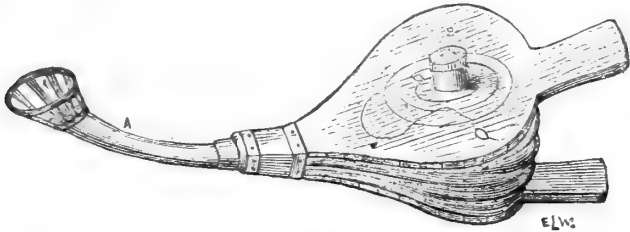

FIG. 6.

A handy pail engine for small occupiers is the Snow's Patent Universal Garden Engine (Fig. 7), which may be fixed in an ordinary pail. The pump is very strong,

forcing a powerful jet either in a single stream or in a thick fog. It is most easily worked. Fig. 8 illustrates the admirable Helmet spray jet by

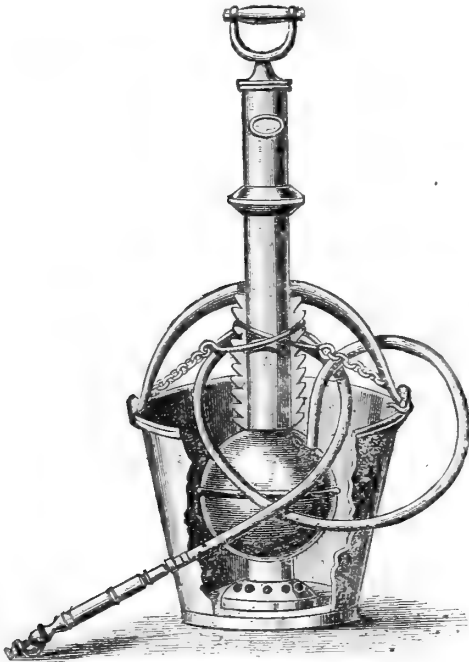

FIG. 7.—Snow's patent garden engine.<sup>2</sup>

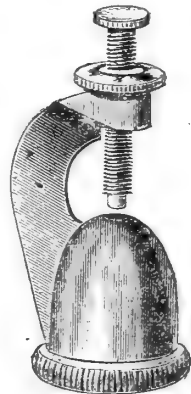

FIG. 8.—The Helmet spray jet.

which plants can be enveloped in the densest mist. This delivery can be regulated by turning a screw.

<sup>1</sup> Messrs. Clark & Co., Windsor Chambers, 20 Great St. Heiens, supply soufflets at a cost of about 3s. each.

<sup>2</sup> This and the Helmet spray jet can be obtained from any ironmonger.

From experiments before alluded to in other countries, sulphate of copper solutions, mixtures, and powders have been proved to prevent and check the action of the potato fungus (*Phytophthora infestans*).

These have been most successfully used in the form of a *bouillie bordelaise*, for which prescriptions have been given above. This should be put on as a preventive from the 15th to the 25th of June, at from 140 to 150 gallons per acre, and again four weeks or so later, especially if heavy rains have fallen. If it has not been put on early as a preventive, a dressing should be given directly the first signs of disease show upon the leaves. For the French experiments, conducted by M. Girard, the bouillie was made of 20 lb. of sulphate of copper and 10 lb. of lime to 100 gallons of water, which is rather weaker than the bouillie used for the vine mildew (*Peronospora viticola*). M. Petermann employed a bouillie of about the same strength in his Belgian experiments at Gembloux, but put on 220 gallons per acre.

M. Thienpont used a bouillie of about 16 lb. of sulphate of copper and 6 lb. of lime to 100 gallons of water at Etichove in East Flanders. M. Petermann made trials also with sulphate of iron, applying it as a bouillie composed of 20 lb. of sulphate of iron and 10 lb. of lime to 100 gallons of water, and putting on 220 gallons per acre. M. Petermann considered this as efficacious as the copper bouillie, and much cheaper.

Besides the Skawinski powder, the Podechard powder may be employed. To make this 11 lb. of lime are slaked in 2 gallons of water and 22 lb. of sulphate of copper are dissolved in  $4\frac{1}{2}$  gallons of boiling water. After this is cooled, it is mixed with the lime and water. This is put over 220 lb. of unslaked lime, which it slakes, and with which it is incorporated. From 20 to 30 lb. are usually put on per acre with the soufflet (Fig. 6).

The *bouillie bordelaise* and other liquid applications can be put on with the Éclair and other "Knapsack" machines, also with the Strawsonizer, which, however, requires to be set upon higher wheels for use among potato plants when they are high.<sup>1</sup> This machine will distribute the sulphate of copper powders equally well, but it must be remarked that these have been found by vine cultivators not nearly so effectual as the bouillies and other liquid forms, though the latter are more costly and more difficult to apply.

---

<sup>1</sup> I am informed that a special machine could be made for potato plants when high.

M. Vermorel has recently brought out a machine on the same principle as the Eclair but drawn by a small horse. It is designed specially for applying sulphate of copper bouillies to

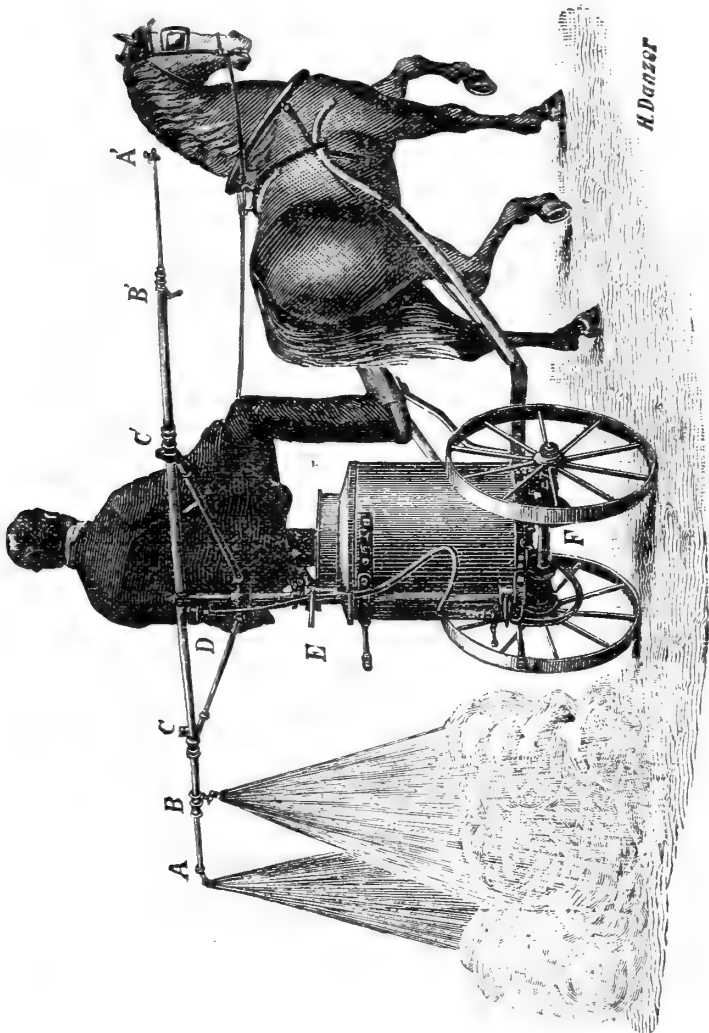

FIG. 9

potato plants. M. Vermorel states that before offering this for sale he experimented with it for two years. It consists of a copper reservoir, holding from 22 to 44 gallons according to the size of the machine, fixed upon two wheels. The wheels move

two eccentrics working the pumps, or diaphragms, like those of the hand Éclair. The liquid is forced up through the tubes and is distributed downwards over the plants through the Vermorel nozzles at A and B, as seen in Fig. 9. The width between the wheels varies with the size of the machine. The smallest machine is only 20 inches wide.<sup>1</sup>

A machine for distributing powdery materials has been recently invented by M. Vermorel. This is called "la Torpille." It is carried on the back like the Éclair, and holds about 23 lb. of powder. By the easy movement of a lever the contents of the metal tank, or reservoir, are discharged through a tube directed at pleasure, and the quantity is governed by a simple arrangement. The cost of this is about 25s.

There are many kinds of hand machines in France for putting on liquid solutions. They are chiefly made in the "Knapsack" form, to be carried on the backs of men and women. The pulvérisateur Japy is a useful machine; the pulvérisateur called "Salvator Folium," made by Berteau et Fils, in the Gironde, is also serviceable, as well as the pulvérisateur Bourdil. In Italy there are several forms of distributing machines of this character,<sup>2</sup> and in the United States there is a surprising number of bucket-pumps, "Knapsack" pumps, and aquapults.<sup>3</sup> Nothing of this kind, however, is more valuable or simple than M. Vermorel's Éclair "Knapsack" pump.

## FRUIT CROPS.

Among the most destructive insects affecting fruit crops are the caterpillars of several moths, particularly the winter moths, the lackey moth, and the ermine moth. Some of these get into the leaf and blossom buds directly the latter begin to form.

The females of the winter and other moths crawl up the stems of fruit-trees in the autumn and place eggs near the buds. It is important to stop their ascent, either by placing guards round the trees or by smearing the trunks to keep them back.

---

<sup>1</sup> The Horse Éclair (Éclair à la Traction) can be obtained at Windsor Chambers, 20 Great St. Helens, E.C.

<sup>2</sup> There is a detailed account of these in the *Istruzione per conoscere e combattere la peronospora della vite*, in the *Annali di Agricoltura*, published by the Italian Ministry of Agriculture, 1886. Rome.

<sup>3</sup> These are fully described, with legions of machinery for distributing insecticides, in the *Fourth Report of the United States Entomological Commission*, 1883-85, published by the United States Department of Agriculture.

One form of moth guard is shown in Fig. 10.

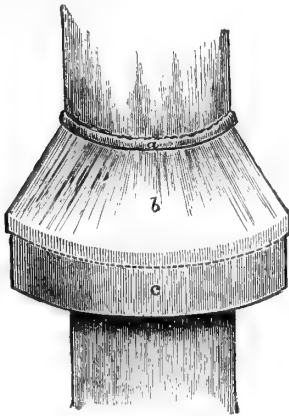

FIG. 10.—A moth guard.

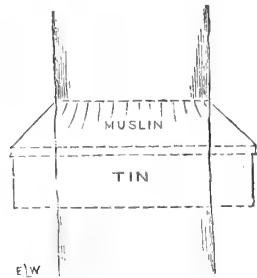

FIG. 11.—Section of moth guard.

This guard is a girdle of tin with a wide rim turned up round inside. It is fastened to strong linen or sacking, and fixed round the tree by a cord, to which the linen or sacking is sewn.

Another kind of guard (Fig. 12) is much used in the United States. It is made of wood or of tin.

These preventive measures will also be of use as regards several other insects which ascend fruit-trees, particularly the caterpillars of the Codlin moth (*Carpocapsa pomonella*), and the female of the apple bud weevil (*Anthonomus pomorum*), which ascends the trees for egg-laying.

Banding fruit-trees with sticky or greasy substances is largely adopted in the United States, in Canada, and in this country to entrap climbing insects. This must be done early, quite by the end of October, in order to prevent the female winter moths from going up the trees, and the bands must be attended to until Christmastide. This practice has been found of the greatest benefit by many fruit growers, and should be adopted and thoroughly carried out in all infested localities.

The best material for this purpose is axle-grease, or cart-grease, composed of oil of resin and carbonate of lime, as this does



FIG. 12.—Another moth guard.

not run like ordinary cart-grease made of animal fats. Care must be taken, as some of the compounds advertised have injured trees. Constant greasing, also, even with the most approved mixtures, is apt to injure the bark. It is well, therefore, to put the grease upon bands of grease-proof paper, as used by grocers, from six to eight inches wide. These can be fastened round the trees with bast or string.<sup>1</sup>

For the attacks of caterpillars upon apple, plum, damson, pear, and cherry trees, sprayings with various compositions have been found useful. These are also of advantage as against the apple-bud weevil (*Anthonomus pomorum*), the apple-sucker (*Psylla mali*),<sup>2</sup> the American blight, or woolly aphis (*Schizoneura lanigera*), the Codlin moth, and other pests.

The compositions employed in order to prevent and check the attack of destructive insects, or to clear them away altogether, should differ according to their various natures and habits. Thus, as has been well defined by Professor Riley and Dr. Packard,<sup>3</sup> those which bite and eat the foliage or blossoms, as caterpillars and the larvæ of saw-flies and the larvæ of beetles, are affected directly or killed by poisons applied to their food, while other classes of insects, such as Aphides and the Cercopidæ, living upon the sap of plants extracted by suction from the leaves or stems, are killed by a direct effect upon their bodies, or are starved out and prevented from reproduction by the unpleasant or unwholesome surroundings occasioned by oily, saponaceous, bitter, pungent, or irritating applications.

For example, caterpillars upon apple-trees would be poisoned by feeding on the leaves sprayed with solutions of Paris Green or London Purple. On the other hand, aphides, for instance of the hop plant, being covered as well as the leaves which they infest with spray from mixtures of soft soap and quassia, or of soft soap and paraffin oil, rapidly disappear. It has not been ascertained whether these act directly upon their bodies, or by making the host-leaves offensive and unbearable.

Washes are various; one has been applied with much benefit in Kent for caterpillars and larvæ of similar habits, consisting of—

<sup>1</sup> The Hon. Cecil T. Parker informs me that he has used vaseline with great advantage for banding fruit-trees. It costs 2½d. to 3d. per lb., and remains sticky throughout the winter.

<sup>2</sup> The injury caused by this tiny insect has only been recently noticed, though, as Miss Ormerod states, it is well known in Britain. Some harm has been caused by it this season in some apple orchards.

<sup>3</sup> *Fourth and Fifth Reports of the United States Entomological Commission*, 1883-1885; 1886-1890. Published by the United States Department of Agriculture,



5 to 7 lb. of soft soap,  
6 to 8 lb. of quassia chips,  
To 100 gallons of water ;

or

5 to 7 lb. of soft soap,  
4 pints of carbolic acid (Calvert's No. 5),  
To 100 gallons of water.

The same quantity of paraffin oil may be used instead of carbolic acid.

Another wash is composed of

6 to 7 lb. of soft soap,  
2 lb. of finely-ground hellebore,  
3 pints of paraffin oil,  
To 100 gallons of water.

In order to mix these washes, the soft soap must be dissolved in a tub with hot water. The quassia chips should be boiled, and the extract put in another tub. When paraffin is used it must be well stirred in boiling water before it is put into cold water. The required quantities of soft soap, quassia extract, or paraffin are put into water-carts containing cold water, which are then driven to the scene of action. A small copper is required, which can be set in a temporary shed, or even in the open, near where the washes are to be used.

#### ARSENICAL INSECTICIDES.

Arsenical insecticides are employed most extensively in the United States and Canada for the Colorado beetle, the cotton worm, the Codlin moth, the canker worm, and many other destructive insects. They are recommended by Professors Riley and Lintner, and many other United States entomologists of high standing. They have been tried in England for two seasons, but not largely, as the fruit-growers are rather afraid of their poisonous qualities.

Where they have been applied with care and thoroughness the results have been decidedly satisfactory, but it must be borne in mind that if washes made with them are too strong they will burn up the foliage and blossoms ; therefore great care and accuracy are necessary in preparing them.

Paris Green or Emerald Green (arsenite of copper) and London Purple (obtained in the manufacture of aniline dyes, and composed of lime and arsenious acid) are the chief arsenical compounds made use of in America and in this country.

In America, according to Dr. Packard, "the efficacy of London Purple is established, and it is generally preferred because of its cheapness, better diffusibility and visibility on

the foliage. London Purple seems also to injure the plant less than Paris Green."<sup>1</sup>

Experiments made with Paris Green in England prove that the proper proportion of Paris Green is—

- For apple trees, 5 oz. to 100 gallons of water.
- „ pear trees, 6 oz. to 100 gallons of water.
- „ plum and damson trees, 8 oz. to 100 gallons of water.
- „ currant trees, 8 oz. to 100 gallons of water.
- „ filbert and cob-nut trees, 6 oz. to 100 gallons of water.

For fruit-trees whose leafage is fully developed, or forest trees, a mixture of 10 oz. of Paris Green to 100 gallons of water has been found satisfactory in America. Two or three pounds of flour are added to this to retain the poison on the leaves.

In her report for May last, presented to the Council of the Royal Agricultural Society by the Seeds and Plants Diseases Committee, Miss Ormerod says:—

“Very great interest is taken in many parts of the country in the treatment for destroying orchard moth caterpillars by application of Paris Green spraying . . . We are continuing to find the benefit of last year's treatment. I have reports from various places, where the Paris Green spraying was used on a large scale, of winter moth caterpillars (up to date of report) being comparatively absent, whilst over a district where (so far as I am aware) little or nothing was done in this way, I have report of the caterpillars appearing in large numbers.”

Paris Green should be obtained always in the form of paste, as it is very difficult to mix it as powder.<sup>2</sup> It is most important that Paris Green mixtures or washes should be kept stirred while being applied, so that they may be of uniform strength, and that 3 or 4 quarts of flour should be added to each 100 gallons of mixture to make it stay upon the leaves.

#### LONDON PURPLE.

London Purple is now sold in the form of a powder. The solution has been withdrawn, as being so much more active in its effects that, unless used very weak and carefully applied in a fine spray, there is distinct danger of injury to the foliage. Dr. Lintner recommends about 1 lb. of powder to 200 gallons of water for ordinary use, and that “eight quarts of flour should be added to cause the arsenite to adhere better to the leaves and

<sup>1</sup> *Fifth Report of the United States Entomological Commission, 1886-1890.* Published by the United States Department of Agriculture.

<sup>2</sup> Paris Green can be had from Messrs. Blundell and Spence, Upper Thames Street, London, at 1s. per lb.; London Purple of Messrs. Hemmingway, 60 Mark Lane, London, at 9d. per lb.

prolong its action.”<sup>1</sup> This proportion would be rather too strong for some fruit-trees in this country. The strength of the mixture must, as also in the case of Paris Green, depend upon the age and condition of the foliage. Young, tender foliage cannot bear so strong a dressing as mature leaves. Much also depends—and this applies equally to Paris Green—upon the manner in which the mixture is put on. If it is sent up on the foliage in drenching showers it must not be so strong as if diffused in fine spray or mist, which is the proper method. The results of various experiments indicate the following proportions:—

- For apple trees, 6 oz. to 100 gallons of water.
- „ pear and cherry trees, 7 oz. to 100 gallons of water.
- „ plum and damson trees, 8 oz. to 100 gallons of water.
- „ currant and filbert trees, 8 oz. to 100 gallons of water.

It is most important that the manner of application should be of the most gentle nature. As to the time, it would be well to spray with a weakish solution just when the leaf buds begin to expand. Spraying should be avoided when the blossoms have opened, and should be done again when the fruit has set, and with a stronger mixture. As the poisons may take some time to cause any effect, patience must be observed, and considerable time allowed to elapse before they are put on again.

In using these arsenical poisons it is obvious that tubs, pails, and all vessels in which they are mixed must be kept solely for this purpose.

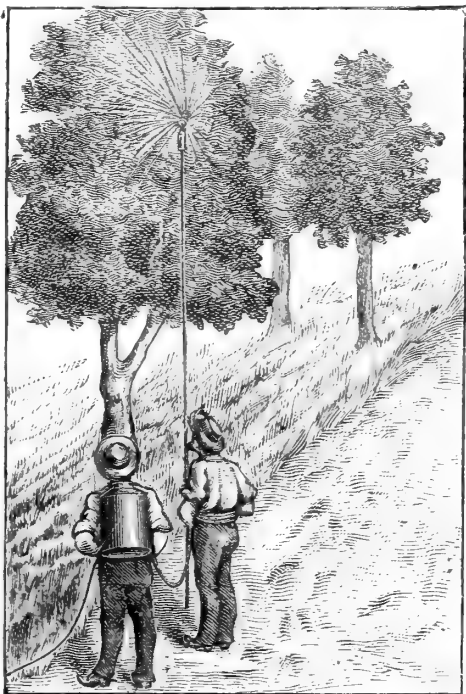

FIG. 13.—For high spraying.

<sup>1</sup> *Fifth Report of the State Entomologist on the Injurious and other Insects of the State of New York, 1889.*

They must not be put on fruit-trees or fruit-bushes whose fruit approaches ripeness. In the cases of currant bushes, and goose-berry bushes especially, whose fruit is often picked when small and green, it would be dangerous to apply them after the fruit has formed. When orchard-trees have been sprayed animals must not be turned in for some long time. Where cabbages,



FIG. 14.—For lateral spraying.

broccoli, lettuces, &c., are grown under fruit-trees it would be dangerous to use poisonous washes, as the folds of the vegetables would retain them.

Paris Green and London Purple are put on with machines having strong force-pumps and nozzles suitable for distributing liquid in the form of dense mist all over the leaves.

The *Éclair* has been found to answer well for spraying trees of moderate height and for all fruit-bushes. The modes of using it for these are indicated by Figs. 13 and 14.

For the fine distribution of liquids there can be no better

nozzle than that known as the Vermorel nozzle. In this nozzle the liquid is driven through a small orifice quite at the side of the globular chambers, and forced up in spray through an aperture in the

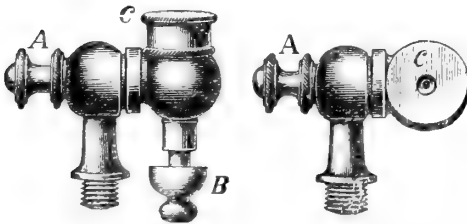

FIG. 15.—The Vermorel nozzle.

*H. Danzer.*

centre of the face or cap as shown at *c*. Fig. 15 shows a recent alteration in this nozzle, giving two globular chambers so ingeniously adjusted that the direction of the spray can be changed by moving the screw cap *A*, without interference with the flow of liquid. The outer chamber is fitted with a spring valve, which being pressed at *B* forces a pin up through the cap orifice and removes any obstruction.

Another good nozzle is the cyclone, or Riley nozzle (Fig. 16), which, like the Vermorel, has for its principal feature the situation of the inlet into the chamber as shown at *e*. This causes a rapid centrifugal movement of the liquid, which issues through

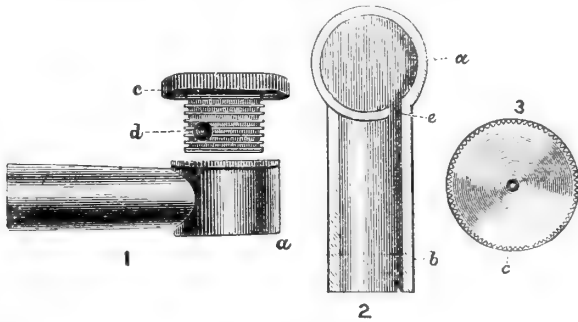

FIG. 16.—The Riley nozzle.

the cap *c* in a funnel-like spray regulated by the size of the aperture. At 1 is given the typical small-stemmed nozzle as it appears when removed from the chamber. The circular body

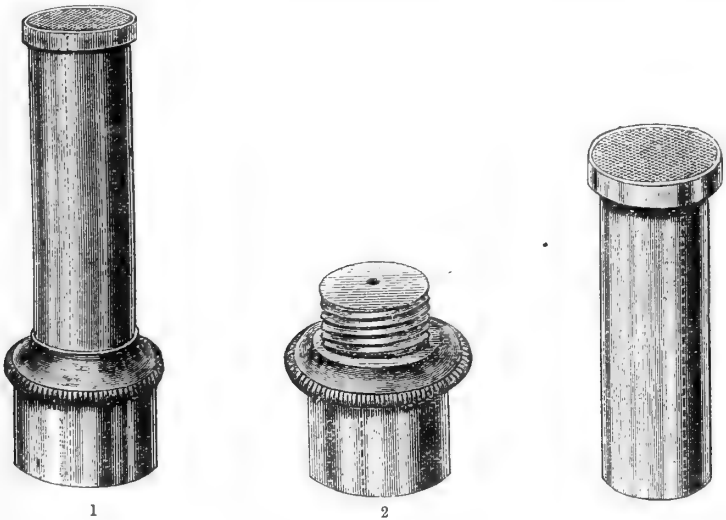

FIG. 17.—The Climax nozzle.

of this cap is chambered out inside and screws down to the bottom of 1, the orifice *d* coming in juxtaposition with *e* shown in the section 2. These parts should meet accurately. The face of the cap is shown at *c*.

There is yet another nozzle worthy of being figured, known in America as the Climax (Fig. 17), whose peculiarity is a long tubular chamber (No. 1), with its face covered with fine wire gauze; through this the liquid is forced from the orifice in No. 2 and divided into fine mist. If a strong pump is employed, liquids are thrown considerable distances with this spray.

For large fruit-trees in orchards and for those in plantations, with fruit bushes or filbert or cob-nut trees set between them,



FIG. 18.

machines like hop-washing engines or large garden engines are required.

There are two sizes of these in use.

The machine shown in Fig. 18 holds 30 gallons. It has a strong pump worked by a lever handle which forces the liquid through the hose. Three men are required for this, one at the pump and two with the hose. Either the Riley, Vermorel, or Climax nozzle can be fixed to this. The nozzle usually fitted

to it is simple, and does not distribute the liquid sufficiently. It must be reiterated that, as a rule, the object in spraying is not to send a single volume of liquid upon the trees or plants, but a dense mist to cover every particle of foliage. This machine has power enough to spray ordinary fruit-trees. In the case of exceptionally high trees the men can stand upon ladders. This is a common practice in the United States. As this machine is about 2 feet wide, it can be worked in plantations where the fruit-bushes are at least 5 feet apart.

The principle of the next size machine is the same, but it is much larger, holding 100 gallons of water and requiring a horse to move it. This is suited for orchards, and the highest trees can be sprayed with it.

Another very useful little machine is made by Messrs. Boulton and Paul, of Norwich. Being only 3 feet 2 inches wide, it can be moved about easily in plantations. It is fitted with two hose for delivery, and has a powerful pump. A peculiarity of it is that it has "dashers" within it for keeping mixtures, as of Paris Green, London Purple, soft soap, and paraffin, well stirred whilst in use. In Fig. 19 it is shown as a watering-cart also, but this apparatus may be dispensed with. A fruit-grower who tried it on bush trees about 7 feet high informed me on April 17 that he had sprayed 6,000 of these, at the rate of 2,500 per day, with 360 gallons of water in which 18 ounces of Paris Green had been dissolved.

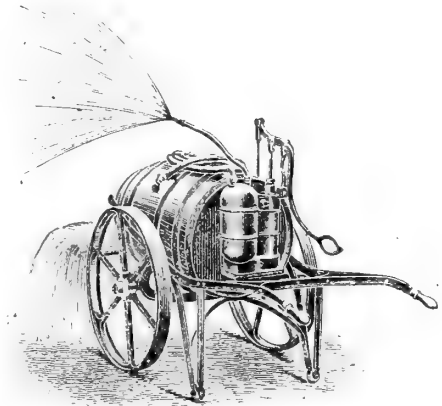

FIG. 19.

"Unless there were some arrangement for elevating the sprayer," my informant adds, "it would hardly answer for lofty standards. The nozzle known as the "Stott" works well with this machine, giving a fine and well-diffused spray (Fig. 20).

A valuable machine introduced from America is Hemmingway's American spraying machine, adapted for the distribution of London Purple, Paris Green, and other insecticides. This is highly spoken of by Professor Riley and other American ento-

mologists.<sup>1</sup> The pump of this machine is very powerful, capable of being worked to a pressure of 100 lb. on the square inch, with a moderate amount of hand power, though 50 to 60 lb.



FIG. 20.—The Stott patent sprayer.

pressure is sufficient. It sends fine mist to the height of 20 feet, and a single stream from 40 to 50 feet high. A short "delivery hose with a small nozzle is inserted in the tank to keep London Purple, Paris Green, and other mixtures uniformly

suspended by continual agitation." Hose to the length of 30 feet can be fitted to this pump, and an arrangement of brass tubing 6 feet 3 inches in length convenient for high trees.

The figures (21 and 22) show the pump working from a pail, and attached to a garden engine.

There are many other machines in use in the United States and other countries. Some are very elaborate and expensive; some are fearfully and wonderfully made; others are simple and cheap. The most practical and useful, however, have been described here,

and it is believed they will be found to work satisfactorily. The Strawsonizer and other horse washing machines have not been



FIG. 21.—Pump detached.

<sup>1</sup> This can be obtained of Messrs. Hemmingway, 60 Mark Lane, London.



described under the head of "Fruit Crops," because it is considered that they would not be practically useful in orchards, on account of the impossibility of covering large trees sufficiently with spray, and getting at all sides of the trees, during their necessarily rapid transit. These horse machines, it is obvious also, could not work in plantations with standards and fruit-bushes growing together. They may be used, with many modifications and alterations, in plantations of fruit-bushes set alone, but not where there are large trees requiring to be sprayed



FIG. 22.—Pump fitted to garden engine.

individually for some minutes. For these, hand-pump machines are essential.

There are just a few more remedies to be noticed under this head. One of these is lime used as a wash for the bodies and larger limbs of fruit-trees, put on thickly and freshly slaked in the autumn. If this is thoroughly well worked into the bark with a stiff brush, many insects in various forms will be dislodged, and the lime adhering to the bark may in a degree prevent some insects from ascending. Lime-wash also removes the green lichenous growths on the stems and limbs of fruit-trees, which serve as a cover for many pests and affect the health of the trees. When fruit-trees, particularly apple-trees, have mosses and lichens upon their branches, harbouring insects in the egg, larval, pupal, and imago form, powdered lime should be thrown

up over them in damp weather. In a short time, if this has been thoroughly done, the mosses and lichens will dry up and fall off. This operation can be performed by men having flour-scoops tied to poles.

Powdered hellebore is very efficacious against the gooseberry sawfly (*Nematus ribesii*) if put on in damp weather. Care must be taken with this, as it is most poisonous. The bushes should not be dusted when the berries are formed. This can be put on with the soufflet (Fig. 6, page 235).<sup>1</sup>

Hellebore may also be used as a solution and applied with the Éclair or other "Knapsack" machines.

For the red maggots of the raspberry moth (*Lampronia rubiella*) which have done extraordinary harm to raspberry growers this spring, lime was put on with an adapted sulphurator, but without much good. This moth appears in June, and where it has been plentiful it will be well to cut the canes back close and burn every particle.

Thick soft soap and sulphur dressings,<sup>2</sup> with paraffin added, may be brushed on the stems of black currant trees infested with the currant mite (*Phytoptus ribis*), whose mischief is rapidly spreading. The dressing should be well worked into the stems with a brush after the bushes have been pruned in the autumn. In very bad cases it would pay to cut all the wood back close, and burn every vestige of it, and work the soft-soap mixtures into the stem. The distorted leaves, or galls, which show upon the currant bushes should be picked off.

In the case of a bad attack of a weevil (*Otiorhynchus sulcatus*) upon young apple and cherry trees, round the tips of whose leading shoots it had gnawed off the bark, it was found that a dressing of very thick soft soap and paraffin preparation put round the stems quite prevented the insect from climbing up the tree. A very little is sufficient, and it is important that it should not be renewed in the same place, or the bark may be injured. These weevils have been very abundant this season, particularly in raspberry plantations. They can only be caught by tarred boards held under the canes at night while they are feeding. As they are in the ground by day, hoeing or digging frequently would move them. Lime dug in might be useful.

---

<sup>1</sup> I sent a soufflet to Mr. Albert Pell, who was anxious to find a machine to apply hellebore to check the gooseberry sawfly in Cambridgeshire. Mr. Pell writes: "You will see by the enclosed card that the soufflet is the right tool, as I felt sure it would prove to be."

<sup>2</sup> Messrs. Barford, of Chiswick, have prepared a compound of soft soap and sulphur, in which the sulphur appears to be fairly dissolved and incorporated with the soap. Miss Ormerod recommends this composition.

## HOPS.

For aphides upon hop plants the planters "wash" or spray the plants with soft soap and quassia mixtures directly "flies," winged aphides, appear upon the leaves, for in a day or two they will produce a wingless generation, termed "lice," and very soon countless swarms will be propagated.

Many remedies have been tried, but nothing is better than a solution of

6 to 7 lb. of soft soap,  
6 to 8 lb. of quassia (the extract of),  
To 100 gallons of water.

Some planters put rather more quassia and less soap, others more soap and less quassia. This application operates by the quassia making the leaves bitter and unpleasant for the aphides to put their suckers in, as well as by the mixture affecting the tender bodies of the aphides.

Another mixture has been found useful composed of—

6 to 8 lb. of soft soap,  
 $\frac{1}{2}$  lb. of tobacco extract,  
To 100 gallons of water.

And one has been tried with advantage, consisting of—

6 to 7 lb. of soft soap,  
3 to 4 pints of paraffin,  
To 100 gallons of water.

In using this much care must be taken to mix the paraffin well with the soap and water while very hot.

Hand hop-washing machines, are principally made use of by planters who have small or moderate-sized holdings. They require three men, two with the hose and one to pump. Supplies of the mixture are carried by men in common pails from the water-cart brought to the outside of the hop garden. Ordinary nozzles are generally used which send the liquid in jet form, not as fine spray, it being still held desirable to send it against the leaves with some force and in some volume, necessitating the consumption of a larger amount of liquid than if spray nozzles were employed. From one to two and a half acres a day, according to the quantity of bine, can be washed with one of these hand engines, and it takes from 200 to 400 gallons of liquid to wash one acre, varying also with the quantity of bine.

Hop-washing machines drawn by horses get over from four to five acres per day. Large planters in many cases adopt these

now, as it is most important to get all the hop plants washed in a very short time when the aphides appear. The smaller machine requires one horse. By the horse machine the

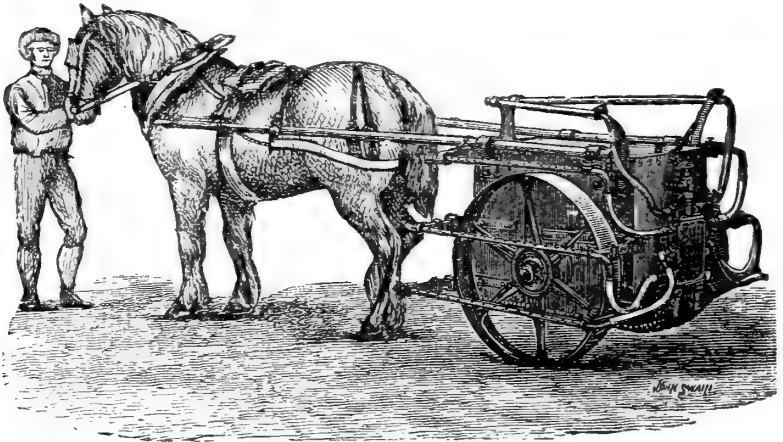

FIG. 23.—A horse hop washing machine.

various washes are forced by strong pumps set in action by the wheels, through a series of tubes arranged with mathematical

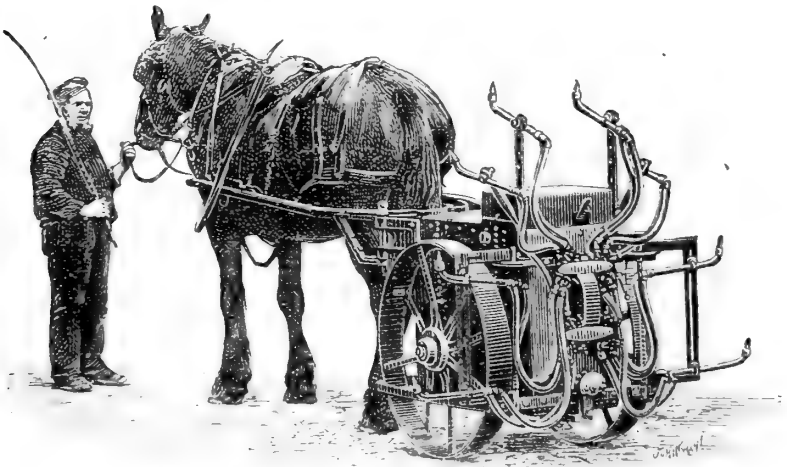

FIG. 24.—The "Mistifier."

precision on each side of the machine, having small perforations at regular intervals, serving as jets or nozzles.

The machine shown in the figure (23) above is made in several

sizes, to contain from 65 to 110 gallons.<sup>1</sup> Two horses are required with the larger-sized machines. From 500 to 700 gallons of liquid are distributed per acre with them.

An improved horse hop-washing machine has been recently patented by Mr. Muirhead, of Maidstone, called the "Mistifier" (Fig. 24).

This is made on an entirely novel principle, embodying a new application of the use of compressed air in combination with the liquid, so that a powerful stream or an atomised mist can be produced. Instead of the series of horizontal tubes with small perforations most liable to be blocked up, rows of pipes with nozzles are substituted. The nozzle attached to this machine is very good, giving a fine, well distributed spray. Swinging pipe brackets are arranged on either side, so that jets can be directed well under the leaves and close to the poles without the possibility of doing any damage to the machine.

From 100 to 350 gallons are used by this machine, according to the setting of the valves.<sup>2</sup>

The Strawsonizer has been adapted for hop-washing, but as it was not ready in time for the last season its suitability for this purpose has not yet been fully tested. In trials of recent date the planters have complained that it does not put on enough liquid, but the contention of the

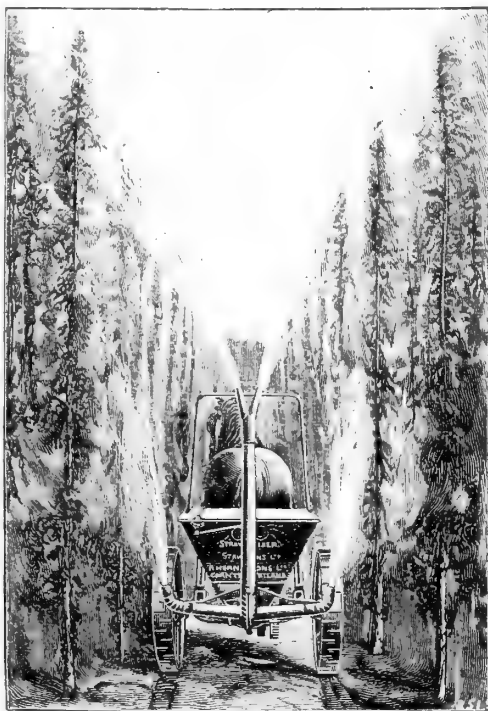

FIG. 25.—The Strawsonizer for hop-washing.

<sup>1</sup> The price ranges from 35*l.* to 48*l.*

<sup>2</sup> The price of this machine is 45*l.*

inventor is that it is better to apply a much stronger wash in small quantities, and in dense mists, so that every particle of the plant may be bedewed, rather than to send it forth in a continuous stream, much of which misses the mark and is simply wasted. Moreover, the wash does not remain so well upon the leaves if it is dashed against them. This raises the important question as to whether spraying with mist, or "squirting," as hop-washing is called by many in Kent, with sharp showers is better. There seems to be much in the argument practically demonstrated by the Strawsonizer. In the Strawsonizer the liquid issues from the nozzles in the form of spray propelled by a strong current of air. The nozzles are placed at the extremity of the air tubes, being fed with the liquid by small pipes connected with the reservoir, the supply being adjusted by intervening taps in any quantity from 1 to 80 gallons per acre. There are two pairs of nozzles for hop spraying; the lower pair takes the bottom leaves, and the upper pair the higher leaves and branches on each side of the machine. It is calculated that the "hop wash" must be used about ten times as strong as that used in ordinary machines, and it is contended that the results are equally satisfactory.

#### THE HOP MILDEW (*Podosphaera castagnei*).

As in the case of vine mildew (*Oidium Tuckeri*), for which sulphur is dusted upon the vines as a preventive measure, many hop-planters put finely powdered sulphur upon the hop plants as soon as they are up the poles. Some use the finest "flowers" of sulphur; others, a coarser kind of sulphur, probably sulphur vivum, containing grit or dust. The purest, lightest sulphur, with the particles most finely divided so that they may get into the interlacing filaments of the mildew, should be used. "Flowers" of sulphur combine these qualities. They are the first products of the sublimating and refining chambers, and fall during these processes in light showers upon the floors and walls. Their particles are spheroidal; to the touch they are unctuous. Sulphur vivum is the last product, or dross; it is heavy and has impurities and varying percentages of earthy admixture, shown by its grittiness. The particles are of irregular shape, and from their weight are more likely to rebound from the leaves when blown on them. Sulphur vivum is from 40 to 50 per cent. heavier than pure flowers of sulphur, and the amount of sulphur in it varies from 50 to 67 per cent., while in good flowers of sulphur the percentage is 95 and upwards.

The action of sulphur is materially influenced by conditions of weather. It is more powerful in heat, when volatilisation takes place, and appears to be inoperative in dull cold seasons.<sup>1</sup> It should always be put on the plants in sunny still weather, if possible, and as soon as they have got well over the poles. Another sulphuring should be given in about three weeks, and a third later on, especially if there are any traces of mildew upon

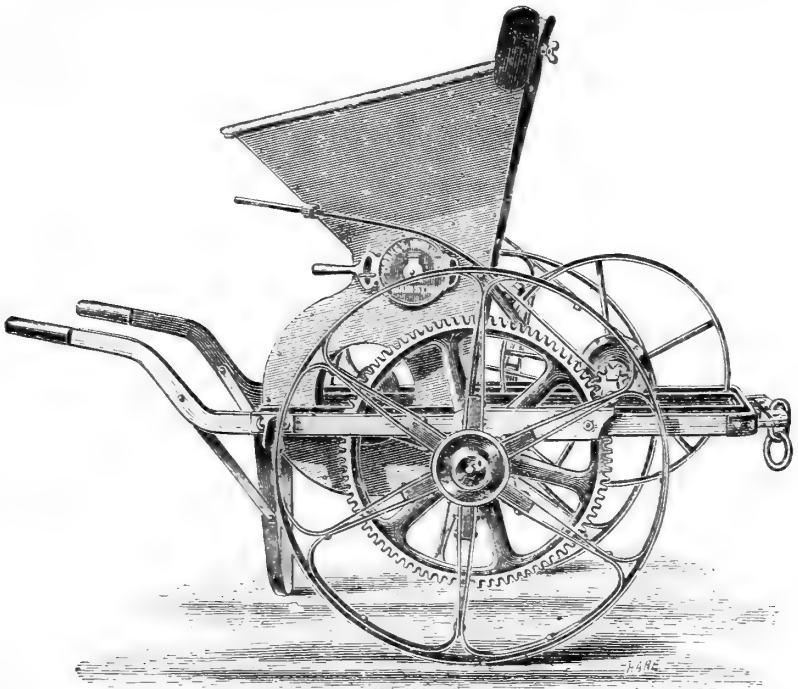

FIG. 26.—Hop sulphurator.

the “burr.” Should the fungus attack the cones when developing or when they are out, sulphur must be used again, though, if possible, this should be avoided, as brewers object sometimes to hops that have been sulphured while fully out.

The quantity of sulphur varies from 40 to 60 lb. per acre, according to its lightness and quality.<sup>2</sup> In France very small

<sup>1</sup> For details, as to sulphur and its effect on hop mildew, see *Mould or Mildew on Hop Plants*, by Charles Whitehead. Clowes and Sons, Stamford Street, London.

<sup>2</sup> The price of sulphur is from 11*l.* to 13*l.* per ton.

quantities are put on at a time, with hand bellows, or soufflets. The hop-planters make use of a machine drawn by a horse termed a "sulphurator," a sketch of which is given in Fig. 26.

This machine consists of a hopper in which the sulphur, or other powdered material, is placed. Air is driven by a fan up a blast pipe, into which the sulphur is fed by a feed-roller with a revolving brush. It is thence distributed in a dense wide-spreading cloud. Having large travelling wheels, and being light, with little friction, the draught is very easy. The feed arrangement can be adjusted while the machine is in motion, by which the amount of sulphur or other powder can be regulated. About five acres per day can be sulphured with this machine.

The price of the "sulphurator" is 12*l.* 12*s.* By cutting a hole in either side of the hopper, the sulphur or other powder may, by inserting a funnel, be directed downwards and distributed over fruit-bushes and low crops, as suggested on page 231.

Sulphate of copper solutions have been tried by a few hop-planters for mildew, but as yet no definite conclusions have been arrived at. It is believed that sulphate of copper would be efficacious against this mildew as it is against the vine mildew (*Peronospora viticola*).

There are other preventives and remedies made use of in hop plantations for insects and fungi, and other machines for applying them. The chief and most important have, however, been given.

It may be explained that in the limited space of an article, whose inception dates only from the April Council Meeting, it is impossible to allude to all the numerous insect and fungoid evils that beset the crops of cultivators, and to the many devices and inventions that human ingenuity has conceived to circumvent them.

CHARLES WHITEHEAD.

---



## THE SURVIVAL IN FARMING.

Two assertions have been frequently made in connection with the depression from which agriculture has been long suffering. One is that high farming does not pay when prices are low ; and the other is that small farmers have withstood the depression better than large farmers. My object is to examine each of these statements, and to ascertain, as far as possible, what degree of truth, if any, there is in either or both of them.

The first assertion, which will be first examined, has at present been given in its barest terms only. Those who make it usually imply, and frequently state, that high farming has been less remunerative, or more unremunerative, than low farming during the period of depression. Some have gone so far as to say that the better a man has farmed the more money he has lost ; while others have not hesitated to declare that the days of high farming are over, and that the cheap and exhaustive system which prevails in America and other new countries is the only type of farming which will survive in the future.

In all questions in dispute a great deal depends upon definitions. The reputation of high farming has suffered greatly through the extravagance and indiscretion of some of its votaries, so that it is important at the outset to state that high farming is not necessarily extravagant farming. It appears to me that the best definition of high farming is obedience to the old and wise injunction : " Feed your land before it is hungry, and clean it before it is foul." Anyone who constantly and thoroughly carries out this direction must be a high farmer. It depends, however, upon the judgment which he displays in obeying the injunction whether he is a good high farmer or a bad high farmer. Those who have thrown the greatest discredit upon high farming have been men whose knowledge of the business they have adopted was in inverse proportion to the capital at their disposal. In feeding land before it is hungry it is necessary to successful results, not only that the land should be fed, but that it should be fed with the particular food which it requires, in such quantities as experience has proved to be desirable under different circumstances. The application of the wrong manures, or of extravagant quantities of the right manures, is likely not only not to yield a profit, but even to do more harm than good. Similarly, in cleaning land before it is foul, discretion as to methods and cost of labour is of the utmost importance. Large sums of money have been wasted upon

costly and useless or unnecessary implements, and more upon hand labour rendered necessary by the neglect of cheaper means of cleaning land.

These statements may appear as truisms to experienced farmers, and yet it is necessary to make them in order to clear away sources of misapprehension. There is, too, another point upon which a disclaimer is necessary on behalf of high farming, and it is this: that ornamental farming is not essential to high farming. It is true that a thoroughly well cultivated farm must always be pleasing to the eyes of an experienced farmer, that well-kept fences are essential to cleanliness, and that there is no economy in letting implements, carriages, and machines rot for want of an occasional coat of paint. Nevertheless, money is often spent for ornamentation alone, and therefore wasted, as far as the business of farming is concerned, so that this item ought to be eliminated in considering whether high farming pays or not.

In short, high farming must be taken at its best in comparing it with low farming, also taken at its best, eliminating, as far as possible, all badness of farming of either the high or the low class. Such a comparison, indeed, would be effected if we could examine the financial records of any given number of high and low farmers in different parts of the country who have survived the long trial of depression, for it may be taken for granted that, as a rule, the incapable members of each division have collapsed. That such an examination is impossible "goes without saying." The nearest approach to it is the ascertainment of the opinions of experienced and extensive observers as to the results of the two styles of farming under the trial of depression, and this means of information I have not neglected, as will be seen presently. Before giving the evidence collected, however, I have something more to say in relation to the statement under consideration and the arguments by which it is supported.

The law of diminishing returns is often cited as proving that high farming cannot pay when prices are low. This law, however, is very misleading when stated without the qualifications which apply to it in great variety under different circumstances. There is a limit, varying with soil, climate, season, and other conditions, beyond which the profit on the production of any crop is in inverse proportion to the expenditure, becoming less and less as outlay is increased, until it vanishes and gives place to loss. It is also true that the lower the price of produce is, the sooner the limit is reached. But it is begging the question to assert, without direct proof, that, at current

prices, the limit is below the standard of expenditure recognised as constituting high farming. If we obtain an increase of 50 per cent. in a crop through putting on the land a certain quantity of manure, it is likely that the use of double the quantity of manure will give a further increase of no more than 25 per cent. In this illustration of the law of diminishing returns it is obvious that the percentage of profit is less on the heavier dressing than on the light one, and yet it may be more than sufficient to cover the extra expenditure. But, if we treble the quantity of manure, the chances are that the produce in excess of that obtained from the double dressing will not be great enough to repay the cost of the extra manure. Indeed, it often happens that a very heavy dressing does more harm than good.

A few years ago Sir John Lawes published an article in which he expressed the opinion that such high farming as was illustrated on some of his experimental plots at Rothamsted was not remunerative at the current prices of corn. That statement was quite true, except that such farming as was referred to ought to have been termed extravagant rather than merely high. The greatest average yield of wheat during thirty-eight years ending with 1889, at Rothamsted, was  $36\frac{1}{2}$  bushels an acre, obtained by the annual use of 600 lb. of ammonia salts,  $3\frac{1}{2}$  cwt. of superphosphate, 200 lb. of sulphate of potash, and 100 lb. each of sulphates of soda and magnesia. No high farmer of experience would dream of using such quantities of manure for a wheat crop, although the application is valuable for purposes of experiment. To parody a well-known saying, it is magnificent; but it is not farming.

The average yield for the same period on a plot to which two-thirds of the quantity of ammonia salts named above were applied yearly, with the same quantities of the other manures, was only  $3\frac{3}{4}$  bushels an acre less than the maximum, and the extra yield did not pay for the extra manure. But this medium dressing of ammonia salts, with the other manures, gave an average yield of  $8\frac{3}{4}$  bushels more than was obtained from the use of 200 lb. of ammonia salts, with the same quantities of other manures; and the application of the extra 200 lb. was profitable even at recent low prices. It is to be borne in mind, too, that the smallest of the three dressings would be a liberal one under an ordinary system of rotation, though not on land continuously cropped with wheat. Under the ordinary rotation, again, the potash, soda, and magnesia, for most soils, might be dispensed with. Even if we take into consideration such high farming as is illustrated on the plot to

which 14 tons of farmyard manure have been annually applied, we see that it paid better than no manure at all. On that plot the average yield of wheat during thirty-eight years was 34 bushels an acre, whereas on the unmanured plot close by it was only 13 bushels. The extra 21 bushels on the manured plot, at only 4s. a bushel, would come to 4*l.* 4s., whereas the manure, at 5s. a ton, would cost only 3*l.* 10s. If any objection be taken to the valuation of the dung, on the ground that 5s. will not cover the cost of carting and spreading, the answer is that the extra straw and chaff obtained would meet any reasonable charge for labour, including the extra expense of harvesting, threshing, and marketing the increase of produce.

We have here a fair comparison between such extreme low farming as is commonly pursued in new countries and high farming, and it is clear that the latter is the more remunerative, or the less unremunerative, of the two systems in this case. It is certain that the extensive production of 13 bushels of wheat per acre every year at 4s. a bushel would soon land the occupier of any farm in this country which would produce that quantity in the bankruptcy court; whereas, it is not certain that the annual production of 34 bushels at 4s. a bushel would not pay, under average conditions as to rent and other expenses, reduced as they are in periods of depression. But while the comparison is a fair one, as between the high and low systems of continuous wheat-growing, it is not by any means the most advantageous comparison that could be given to show the superiority of high farming. A better one, even of the same character, is afforded in the case of the Rothamsted barley experiments. The average yield of a plot manured annually with 275 lb. of nitrate of soda, and 3½ cwt. of superphosphate, was 45½ bushels during thirty-eight years, while the average yield of two unmanured plots in the same field was only 17½ bushels. The cost of the manures, at recent prices, was about 35s., and the extra barley obtained on the manured plot was over 28 bushels an acre, which at only 3s. 6*d.* a bushel would bring in 4*l.* 18s. The application of such a dressing, for barley grown in an ordinary rotation, would be high farming, and on land in good condition it might be too much. Similar comparisons might be drawn from the results of the Woburn experiments.

Other striking examples of the remunerativeness of judicious manuring may be taken from the records of experiments on the mangel crop carried out last season by the Bath and West of England Society. These experiments are particularly convenient for the purpose now in view, because the cost of each dressing of manure is given, as well as the yield of roots. The

Average results obtained at twenty-three stations show that the greatest yield—a little over 29 tons—was obtained from the application of 4 cwt. of nitrate of soda, 4 cwt. of superphosphate, and 4 cwt. of salt per acre, costing 2*l.* 15*s.* The average yield of two unmanured plots at each of the twenty-three stations was not quite 15 $\frac{3}{4}$  tons, and the increase on the manured plots just referred to averaged nearly 13 $\frac{1}{2}$  tons per acre, costing 4*s.* 2*d.* per ton. Where half the quantity of nitrate of soda was used, with the same quantities of superphosphate and salt, the increase was about 2 tons less, and the cost of the increase was only 3*s.* 3*d.* a ton.

Now, the law of diminishing returns is sometimes applied as if it meant that the returns obtained when capital is expended in manure are necessarily less in proportion to cost than those of land left to its natural resources. The comparisons just given show how entirely mistaken this idea is. In the case of the barley, the increase on the manured plot cost only 1*s.* 3*d.* per bushel, and it is certain that every bushel grown on the unmanured land cost a good deal more than that amount. Similarly, in the case of the mangel, the extra produce on one set of plots cost only 3*s.* 3*d.* a ton; whereas, the 15 $\frac{3}{4}$  tons grown on the unmanured plots must have cost at least double that sum, because the quantity at 3*s.* 3*d.* a ton comes to only 2*l.* 11*s.* an acre. Further, out of ten sets of manured plots the increase over the produce of the unmanured land cost 6*s.* 7*d.* a ton or less, although the manure, including dung in two cases, ranged in cost up to 3*l.* 8*s.* 6*d.* an acre; and, as a ton of mangel is worth more than 6*s.* 7*d.*, it may fairly be said that every one of these seven dressings was remunerative, and that, therefore, the law of diminishing returns did not apply to it. Similarly, in the case of grass land, it might be shown, by citing the results of Mr. Martin John Sutton's experiments, that the increase obtained by the use of certain manures cost less than the produce of the unmanured land.

On virgin land, obtained free of cost, the case might be different, although I imagine that few virgin soils would grow more than 15 $\frac{3}{4}$  tons of mangel per acre without manure, and, if I am right, the application of manure might be profitable. It is obvious, however, that the natural produce of rent-free virgin land costs much less than that of land in this country, and that, therefore, the law of diminishing returns would more quickly come into play in the former case than in the latter.

In short, the abstract argument in favour of judicious high farming is this—that the cost of growing a small crop with little or no manure is nearly as great as that of growing a great

crop with a liberal allowance of fertilisers, except for the difference in the cost of the manure. The other expenses of farming are but slightly affected. A good crop costs less to keep clean than a poor one, but more to harvest and dispose of.

The question becomes more complicated when we have to consider high farming consisting in the keeping and liberal feeding of a large number of live stock in proportion to acreage. Here a great deal depends upon the judgment and business capability of the farmer as buyer and seller, upon the question whether the stock are bred and reared at home or bought in as stores to be fattened, upon the class of land upon which the animals are kept, upon skill in feeding, and upon other considerations. To simplify the question, poor grazing land, only fit for the breeding and partial rearing of stock, such as the hill districts of Wales and Ireland, may be left out of account. The small area of very rich pasture in the country may also be set aside, with the remark that if it is well stocked with fattening animals it cannot be badly farmed. Wholly arable, or mixed arable and grass farms lend themselves best to the discussion now before us.

Unfortunately there is a "plentiful lack" of exact records of the cost of keeping stock, or—and this is of more importance to the question at issue—of the cost of the manure which they leave upon the farm. There is, I believe, a general concurrence of evidence to the effect that the most remunerative method of fattening stock reared on the farm is that of keeping them "doing" from the first, and selling them at an early age. Where this system is pursued, with a sufficient number of animals, it is necessarily high farming, as cake or corn is constantly being consumed. At various times I have heard or read of many instances in which stock so reared left so goodly a sum for their keep that the cost of the manure they made must have been very little. Indeed, I have heard of instances in which cattle were said to have paid well for everything they had eaten, though I have never seen a properly-kept account proving this, except in relation to breeding or dairy cows. With sheep and lambs, however, such good fortune is not very uncommon when the markets turn in favour of sellers, and this remark applies to fattening as well as to breeding. Now, the low farmer would keep fewer stock in proportion to his acreage than the high farmer, and, as a rule, an inferior description of stock, while he would not allow them much purchased food or home-grown corn. As a breeder, the low farmer has been simply "nowhere" in recent times, as he has not invested capital enough

in his business to produce the prime animals which have made all the running. As a feeder, again, he has been shut out of the advantages obtained from early maturity in fattened stock. It is doubtful whether his manure has not cost him as much to make as that of the judiciously liberal feeder, and it has not been worth half as much when made. There is, no doubt, a great deal of waste in giving cattle excessive quantities of cake; but such extravagance, except for show beasts, is less common, I believe, than it was some years ago. The principles of feeding are more generally understood than they were when nearly every farmer despised "book-knowledge," and the wastefulness referred to has been fully exposed. It is characteristic of reckless and extravagant farming, and not of such judicious high farming as is alone worth defending.

A low farmer may be, and often is, a capital judge of stock, as well as a very keen higgler. There are low farmers, too, who keep a few stock well, and others who keep a good many poorly. In either case a good buyer and seller may often make a profit if he catches the market in his favour; but this does not help the condition of his farm, and he must be a dealer rather than a farmer if he is to make up for inferior crops by profits on live-stock. A man who keeps a fair number of stock in proportion to his acreage, and feeds them well, cannot be a low farmer. There are various grades of highness and lowness in farming—so various that the line of demarcation may be difficult to draw in some cases; but, for the purposes of my argument, I have nothing to do with the class, if there be one, which may be said to represent a mean between the two main divisions, and there are comparatively few farmers who cannot be said to verge towards one or the other.

Recalling my definition of a high farmer as one who feeds his land before it is hungry and cleans it before it is foul, I wish now to call attention to a type of farmer entitled, in my opinion, to be classed as high, although perhaps this may not be generally allowed. A case which was under my observation for many years may be described as illustrating this type. This farmer's land was heavy, and chiefly arable. He did not breed or dairy, as his land would not bear stock in winter. In summer he fed off most of his green crops with fattening sheep, which had a moderate allowance of cake, reserving only enough clover and grass for hay for home consumption. In winter he fattened as many cattle as he grew roots for, giving them cake and corn as well as roots and hay. The cake was the only fertiliser which he brought on to his farm, as he did not buy any artificial or other manure. His theory was that "a farm should baste

itself," and his only departure from that principle consisted in the purchase of a moderate quantity of cake. He adhered to the four-course rotation, and he grew excellent crops. His farm was well horsed, so that he was always forward with his autumn cleaning of stubbles, and with the ploughing of his land for spring corn and roots before winter set in, also with the cultivation of land on which tares had been mown or fed. Thus his land was always clean, as well as in good heart, and but little hand cleaning of his crops was necessary. His expenditure was not heavy; but he was, in my opinion, unquestionably a high farmer. He saved money even after the period of depression was well on its way, and the condition of his farm was improved in a marked degree during his tenancy.

Before the discovery of what was until recently the missing link in the theory of the conservation or increase of fertility in farmed land, English chemists would hardly have admitted, without direct proof, that my old neighbour could have been improving the condition of his farm: because, they would have said, the cake brought on to the land was not sufficient to restore the elements of fertility sold off in corn, meat, and wool. But now that it is admitted that the growth of clover, tares, and other leguminous crops increases the fertility of the soil, at least as far as the supply of nitrogen is concerned, there is no difficulty in explaining why the farm was improved in condition. It is desirable to point out, however, that the system pursued would not have been high farming on light land, as it would not have kept up the fertility of any soil which did not possess a practically inexhaustible supply of potash and other minerals.

On some equally good land near the farm just mentioned, there were two or three farmers who kept scarcely any stock, and purchased no cake worth mentioning, and no manure. They kept their land fairly clean, and grew good crops of corn in hot seasons, but frequently had very poor crops, and they did not survive many years of agricultural depression. This reminds me of an advantage which low farmers have in such seasons as the last two, when all the heaviest of the corn crops are badly laid, while their crops may be just too light to go down, though fairly good. The tendency of heavy corn crops to lodge is the greatest of all the disadvantages of the high corn land farmer. At present, chemists have not succeeded in discovering any remedy, or even palliative, to this evil, and all that can be done to prevent it is to be careful not to sow too thickly or too early on land in high condition, and to grow stiff-strawed varieties of corn.

There are low farmers who are also clean farmers, and when



such men take a farm in good condition, they often grow satisfactory crops for many years. The experience gained in connection with the unmanured plots at Rothamsted and Woburn shows how very slow the decline of fertility is in land kept free from weeds. It is not surprising, then, that members of this best division of the low farming class often make a good living during a long tenancy. But the examples given above show that they could produce extra corn and roots at less cost than that of what they grow if they applied purchased manure judiciously; and, I believe, although actual proof is not easy to give, that they would also be better off if they kept more live stock and fed the animals well.

So far as my own experience goes, the farmers who have done best, both before and since the depression set in, have been those whom I should describe as high, but not extravagant farmers. I can call to mind only one low farmer who appeared to increase in wealth, though I have known others who have held on to their farms surprisingly, "with their noses always just over the grindstone." But one individual's experience does not count for much in relation to such a question as the one under notice, and, mindful of the fact, I have obtained from a few land and estate agents in extensive practice in different counties the results of their observation and their conclusions thereupon.

The questions to which replies were solicited were these:—

1. What class or classes of farmers have best withstood the effects of agricultural depression in your district: (*a*) high (I do not mean extravagant) farmers, or low farmers; (*b*) farmers of large (over 300 acres), medium (100 to 300 acres), or small (under 100 acres) farms?

2. What have been the principal causes of the failure of those who have not succeeded, and of the success of those who have withstood the depression?

In reviewing the replies received, reference to the second assertion referred to at the commencement of this article is necessary. This question is essentially one to be decided by evidence. The definite assertion is made that small farmers have withstood the depression better than large farmers. This may be true of some districts, and not of others, the question being whether it is true as a general rule. In the event of the assertion being verified, a further question would arise as to the reason why small farmers have withstood the depression better than large farmers.

Two of the most extensive land agents in the north of England, who do not desire their names to be published, give some-

what conflicting evidence in relation to each of the two questions. One, whose observations have been made chiefly in Cumberland and Westmoreland, where stock-rearing is the prominent feature of the farming, with dairying in the second place, says that "good farming (high, but not extravagant) has stood the depression the best"; and that not many failures have taken place, while "those that have occurred have generally been amongst the smaller class." The other witness, confining his remarks to Cumberland, says that "industrious working farmers, who personally superintend their own business thoroughly, not being amateurs, have best withstood the depression." He agrees, however, with the other observer in stating that farmers holding 100 to 300 acres have held their own best. But while the former witness names want of sufficient capital as the principal cause of failure, the latter says "insufficient practical training and want of steady application." Conversely, the latter witness attributes the success of those who have attained it to steady and continuous attention to business on the part of industrious occupiers who have an adequate knowledge of live-stock.

Writing in relation to another pasture district, the North Midland dairy and breeding country, Mr. Gilbert Murray says that "the men who have held their own are those who have bred their own stock and consumed the principal part of the cereal produce of their farms, and, in addition, have been large purchasers of supplementary foods at low prices;" also that "farms of 80 to 200 acres have been most remunerative, owing to the labour difficulty, wages being now 18s. to 21s. per week." Insufficient capital to stock the land is named as the chief cause of failure.

Extensive grazing and dairying districts, as well as a considerable area of arable land, are covered by a report from Mr. J. Perkins, junr., of Loughton, Rugby, whose observations relate to parts of Leicestershire, Northamptonshire, Rutland, Warwickshire, Staffordshire, and other counties. He is of opinion that large graziers, breeders of sheep and cattle, dairy farmers on suitable holdings, including makers of Stilton and other kinds of cheese, have done best. "High farmers," he says, "have best held their own where they used skill and judgment;" and, although "low farmers have often saved money," in too many instances it has been "at the expense of the land." "These remarks," Mr. Perkins holds, "apply to every sort and size of farm." Insufficiency of capital and want of judgment in buying and selling, as well as circumstances which affect all farmers alike, and which therefore do not elucidate the question at issue, are named as the causes of failure where it has occurred.

In the fine grazing and dairying district of Mid Bucks, according to Messrs. Reader & Son, of Aylesbury, the farmers who have best held out against the depression are "those occupying the largest farms, with that all-powerful motive-power, a sufficiency of capital, enabling them to retain their corn, cattle, &c., to await the best markets, and make the best of any advantage either in purchasing or selling. Very few farmers have actually failed in the district."

More than half the total cultivated area of Sussex being in permanent pasture, the report of Mr. J. Plumer Chapman, of Lewes, on East and Mid Sussex, may be included among the replies from pastoral districts, especially as it relates chiefly to dairy farms, from which milk is extensively sent to London, Brighton, and other towns. Excluding the hill farms, the holdings are not large, and Mr. Chapman declares in favour of small farmers as those who have best withstood the depression, and especially men who have given up wheat-growing to a great extent, substituting green crops, and keeping more stock. Insufficiency of capital to begin with, or after losses, is given as the chief cause of failure. "Those who have done best," Mr. Chapman adds, "besides sheep breeders, have usually been of the small trading class, who dispense with the service and profit of the middleman, and who have farmed at the least possible working expense."

Still selecting replies from districts mainly pastoral, the next to be noticed is one from Mr. William Sturge, of Bristol, a past President of the Surveyors' Institution. Writing from long experience in Gloucester, Somerset, Wilts, Hereford, Monmouth, and South Wales, this gentleman says in relation to all sorts of farms:—"I do not think high farmers have done better than others. Dairy and grazing farmers have done fairly well with an abatement of rent of 10 to 20 per cent. Farms of this class rarely exceed 300 acres. On the whole, small working farmers have done best. Arable farmers can hardly make both ends meet with reductions of 30, 40, and even 50 per cent. in rent." Success or failure, Mr. Sturge appears to think, has depended mainly upon the proportion of pasture to arable land.

The head agent on one of the most important estates in the country, whose name is not to be published, refers to great dairy, grazing, and arable districts in Cornwall, Devon, Dorset, Wilts, and Somerset. In this reply no opinion is expressed as to the superiority of high or low farming from an economic point of view, the writer appearing to be impressed mainly with the idea of industry and skill being the great essentials to success.

Occupiers of small and medium farms—the latter not over 200 acres, he says, have best withstood depression, and he ranks the two divisions equally in this respect. The reason he gives for their having held up better than large farmers is that the difficulty of managing labourers and leading them on in their work is increased when farms exceed 200 acres. On farms of the size named or less, it is remarked, “the farmer is foreman himself at all work.” Besides bad seasons and the lack of timely reductions of rent, the principal causes of failure are declared to have been the farmers’ “lack of economy in management and inability to suit their habits of living to altered circumstances.” The causes assigned of success in withstanding depression are reasonable rents or timely reductions, with good management and economical habits of living. For the consideration of the ladies this correspondent adds:—“I attach to the wife of the medium and small farmer more than half the credit or blame of success or non-success in the business.”

So far the evidence, as selected from pastoral districts mainly, is not overwhelmingly in favour of the views expressed in the preceding portion of this article, as the two last witnesses and one Cumberland correspondent are clearly not impressed with the virtues of high farming in periods of depression, and both favour small or medium farms rather than large ones. On the other hand, it will be noticed that the other correspondents quoted, so far, are more or less distinctly in favour of high farming, and dwell upon the importance of sufficiency of capital. On the whole, it appears that in some of the grazing and dairying districts referred to, large farmers have done best, while in others small or medium occupiers have had the advantage.

Turning to evidence from districts in which arable or mixed farming prevails generally, I find no distinct answer to my questions in a reply from a Lancashire correspondent, who is of opinion, however, that small farmers lose a great deal by absenting themselves from their business to attend two markets in a week, not, as a rule, to buy or sell, but, as they explain—“just com’ to see hoo things was goen.” Apparently, the farmers in the Lonsdale South-of-the-Sands district, to which the writer mainly refers, as a rule, have passed well through the depression, whether they are large or small occupiers.

Writing on North Yorkshire and Durham, Mr. Samuel Rowlandson says that the farming on the east side of these counties is generally mixed arable and grass, and on the west side chiefly moorland, devoted to dairying and grazing. The moorland farmers have stood the depression best, as their young cattle and lambs have made fairly good prices, while cheese has

sold pretty well. In the mixed farming districts the low farmers had the advantage during the wet seasons; but "in fair average seasons, good—not extravagant—farming will always answer the best." As to whether large or small farmers have best withstood the depression, Mr. Rowlandson says that there is no rule, as "it has depended entirely on the man himself, and the farm he occupied." He adds—"No doubt, a man with a large family of sons, all workers, has apparently done the best; but in many of these cases the wage due to the sons has not been paid. This practice has often enabled a man to pay a much higher rent than he would, had he paid for his labour, have been able to afford." The failure of some, according to my correspondent, is attributable to their occupying a larger acreage than they had capital for, and that of others to incompetent management; while rare business capability, skill in the buying and selling of stock, close attention to all details, and practical knowledge of all farm work, have enabled many to succeed in spite of the depression.

Mr. William Abbot, of Holbeach and London, says that in the South Holland district of Lincolnshire, where arable and grazing farming prevail, high farmers have passed through the period of depression better than low farmers, and large and medium occupiers better than small holders. High rents under leases taken in better times are mentioned as having caused many failures. "With low farming," it is added, "small yields have resulted, and, market prices ruling so low, produce has not made sufficient to cover expenses." Moreover, "store stock have been purchased very dear, and sold when fat very cheap." But "farmers who have farmed high, and got good crops, have been able to meet the markets better," and "some graziers have been more fortunate than others with their stock."

In Bedfordshire, with its mixed farming, according to a firm of land agents in extensive practice, "the best farmers," and those occupying "large and medium-sized farms," have passed through the bad times most successfully. Apart from the low price of corn, and the depreciation in the value of fat stock, insufficiency of capital is named as the chief cause of failure; and, conversely, the possession of plenty of capital, and the skilful farming of good land, are given as the sources of success in withstanding depression.

Mr. Charles Elsworthy, of Upwell, reporting on Cambridge-shire, where the farming is chiefly arable and grazing, says that, "taken upon the whole, medium and small farmers have withstood the depression best," and that the principal cause of failure has been "lack of capital." Grazing last year did badly, but

arable better, chiefly because potatoes were extensively grown, and sold well. The reference to lack of capital as the chief cause of failure, tells in favour of high farming.

Very distinct answers to my questions are given by Mr. H. J. Gayford, of East Raynham, Fakenham, in relation to North-west Norfolk, where the land is nearly all arable, and there are few farms under 100 acres, the general run being from 500 to 700 acres, with some up to 1000, and a few larger. He writes: "The men who have best withstood the depression are men of business capacity, with ample capital, who have always been well stocked, and have been able to economise in working expenses, and to purchase in the cheapest markets." Similar in purport is the statement that want of capital has been the chief cause of failure, and sufficient capital and enterprise the secrets of success. As to the few small farmers, Mr. Gayford says that their land is "generally badly farmed," and that they are "doing badly."

Mr. G. E. Walker, of Woodbridge, writing on East Suffolk, where the farming is chiefly arable, says that the large occupiers and those who have farmed well have come through the trial best, though a few of the small farmers have done well where the land is extra good. Increase in the cost of labour and want of capital are named as the chief causes of failure, while farming well and paying special attention to breeding have been instrumental in keeping farmers from ruinous losses, the county having distinct breeds of horses, cattle, and sheep.

With respect to Essex, where the farms are chiefly arable, the verdict of a well-known firm upon the county as a whole is that farmers who have farmed well, so as to keep up their occupations to a fair standard, have met the bad times best. No general rule applies as to size of farms, success or failure having depended upon the ability and capital of the tenant. The causes of failure mentioned are unpropitious seasons, the low prices of produce, the high prices of store cattle and sheep, and the low prices of fat stock. On heavy soils, adapted only for corn, prices, it is added, have been ruinous, although landlords, in the experience of the writer in all parts of the county, have reduced rents from 20 to 70 per cent.

Referring in general terms to all the Home Counties, Messrs. Simmons & Sons, of Reading, write as follows:—"Our experience of the last ten years is that the men who have stood their ground best in the face of the depression which has affected agriculture have been those who have occupied farms of about 250 acres, with a proportion of at least one-fourth grass, and who have directed their attention to the rearing and raising of

stock of all kinds. The causes of failure have been chiefly where tenants have tried to cultivate large arable farms with insufficient capital, relying almost entirely on the corn crop for profit. High farming on arable land has not been profitable, our experience being that a large outlay in respect of artificial feeding stuffs has failed to secure anything like a profitable return. On the other hand, those who have kept no stock have been the first almost to go to the wall. Undoubtedly, in this neighbourhood, and as far as our experience extends in any part of the district embracing what may be called the five Home Counties, the system which has held its own out of all others has been that of keeping a breeding flock in proportion to the extent of the arable land, and rearing every year a certain number of calves, thus avoiding the necessity of going to market, when, as has so often been the case in recent years, there has been no prospect whatever of a margin of profit between the price demanded for store beasts and the prospective price to be realised by their sale at the end of the season. The greatest mistake a tenant can make is to attempt to farm more land than he has capital to properly stock, and if more attention were directed to the breeding and rearing of all kinds of agricultural stock, there would, in our opinion, be fewer cases recorded of ruined agriculturists than we have, unfortunately, been accustomed to witness during the past decade."

The reply is quoted at length because there are two or three important points in it. It will be observed that Messrs. Simmons, while pronouncing against the remunerativeness of high farming on arable land, dwell more emphatically still upon the importance of having sufficient capital for the acreage held. Therefore, it may fairly be said that they regard low farming as more dangerous than high farming. Probably, if cross-examined, they would explain that it is only what they deem extravagant high farming that they find unremunerative, and not what is termed "good" farming. Some other points in their evidence which are particularly well put, come out also in the majority of the replies, and will be commented on presently.

A land agent whose practice is chiefly in Mid-Kent, where arable, hop, and fruit farming prevail, says that, leaving out of consideration the hop and fruit farms, high farmers have certainly withstood the depression better than low farmers. The chief causes of failure given are want of capital, the starving of the land, and the "absence of business habits to such an extent that it is surprising that many have ever got a living."

Mr. W. Frank Perkins, of Southampton, writing on experience gained in the county of Southampton, says:—"We

have so few high farmers here, that I am unable to give an opinion. Certainly the smallest farmers, who dairy and grow vegetables, and retail in their own carts—men of 20 to 50 acres,—have done best around here.” Insufficiency of capital, the fall in wheat, sloth in adapting their trade to the exigencies of the times, and reckless borrowing of sharpers, are given as the causes of failure; while those who have succeeded owe their success to their judgment in dealing in stock, the production of saleable crops, milk, and butter, and to humble living, the family assisting in the labour of the farm.

One of the best known land agents in Wiltshire, writing on the mixed farming districts of the Southern, Western, and Midland Counties, states that, as a rule, men who have pursued recognised systems of farming, with sufficient capital, and have conformed by domestic thrift to the reduced earnings of their farms, have best withstood the depression; also that farmers of about a hundred acres in grass districts have done best, while those holding over three hundred acres of arable land have suffered most. My correspondent adds:—“The losses incident to 1879 and following seasons largely reduced the capital of the tenant, with the result that borrowed capital was imported to an excessive amount. No improvement in prices or physical conditions occurred to enable farmers to meet their increased burdens. Hence a large class of tenant farmers absolutely disappeared, who are not yet replaced by others, which accounts for the inability to let large arable farms.”

Taking into consideration the fact that insufficiency of capital is given as the principal cause of failure in the great majority of the replies to my questions, it may fairly be said that, on the whole, they tell strongly in favour of such moderately high farming as has been advocated in this article. No doubt, reduction of expenses, referred to by several correspondents, has been essential in a period of small returns; but the reduction should not consist in the starving of the land. The bills which have been cut down to the greatest advantage have been, not the cake or the manure bill, but the household and the labour bills. There is no doubt that a good deal of superfluous and unremunerative labour was employed in the “good old times,” especially in counties where wages were low. In my opinion, nothing is less remunerative on a farm than hand labour which is not absolutely necessary. The land must be kept clean, no doubt; but it should be, as far as possible, by the plough, the cultivator, the harrow, and the horse hoe, rather than with the hand hoe. Another economy mentioned in the replies is that of dispensing with the services of middlemen,



and this is highly desirable, and might be managed to a much greater extent than it is. The possibility of selling a good deal of their produce by retail is one of the chief advantages which small farmers enjoy, though the greatest of all is the economy of labour which they effect by working with their men, and often by employing members of their own families. On the other side may be set the economy effected on large farms by the use of labour-saving implements and machines.

Another point alluded to by most of the witnesses is the need of keeping the land well stocked, which is also an argument for high farming. Skill in the buying and selling of stock is as frequently mentioned as essential, and general business ability is dwelt upon in several instances as the reason why some men have held on during the depression, while their neighbours have gone under. Business ability is, of course, essential in all branches of industry and at all times; but it has been peculiarly important in farming under the long and severe strain to which that industry has been subjected.

The advantages of breeding stock of all kinds are alluded to by several correspondents, and Messrs. Simmons particularly point out the benefit of rearing a certain number of calves every year. Apparently breeding has greatly extended of late upon medium and small farms, and if we can but clear the country of pleuro-pneumonia, as we have cleared it of foot-and-mouth disease, a further extension of this desirable movement may be expected. At such a time the opening of this country to American stores would be a calamity of the worst description. The subject is too large to be dealt with fully in this article; but, in connection with the evidence given above, it is not out of place to protest against the shortsighted views of those who would incur a great danger in order to get cheap lean stock for a year or two, or perhaps only for a few months. Home breeding would be crippled if the American stores came in great number, and dairy farming would be seriously injured through the rearing of calves being rendered unremunerative. Sooner or later, too, disease would be brought over by the foreign beasts—possibly Texas fever, and probably pleuro-pneumonia, and then, after we had been led to rely upon the foreign supply of stores for fattening, they would be shut out of the country, and something like a lean-stock famine would result.

During the last ten years the struggle for existence among the different systems of farming in the world has been severe, and the results appear to me already to show very clearly which is likely to prove the fittest, and therefore to survive. It is a notable fact that while the wheat area of Europe during the

period has increased, that of the United States and Canada has barely been maintained. Moreover, in the last five years, that of Australasia has increased by only about 200,000 acres, and the Indian acreage has fallen off. The wasteful cattle range and ranch systems of America, too, have been entirely unsuccessful of late, as is demonstrated by the fact that the number of cattle this year has failed to show an appreciable increase for the first time during twenty years, and population has been gaining ground upon cattle. Bearing in mind the fact that, during the past decade, millions of acres of new land in the United States and Canada, in which wheat is almost necessarily the first crop, have been occupied, and that, therefore, as the total acreage has been stationary, an area equal to that of the new land must have gone out of wheat cultivation, the unremunerativeness of wheat-growing in these countries may be considered proved. The whole tendency of farming in these countries is towards mixed husbandry and the production of fruit and culinary vegetables, and this means an advance in the direction of high farming, which will be accelerated with the rapid increase of population, at least in the United States. I do not agree with the prophets who predict that, in ten years, America will have ceased to export grain and meat, because I believe that higher prices will induce better farming, which will increase the fertility of the soil and therefore the yield of crops, while meat will be produced on millions of farms under an economical system, instead of under the cheap, but wasteful, range and ranch systems.

Is it credible, then, that while America is advancing towards the British system of farming, we, in this country, will retrograde in the direction of the present American system? The answer is obviously a negative one. With the best markets in the world within easy reach, British farmers will find that their interests will lie in the production of the greatest quantity of the best of everything. The depression has taught them some useful lessons in economy, one of the most important of which is that they cannot afford to bid recklessly against each other for farms. But the economy which will be practised will consist in the curtailing of wasteful business and personal expenditure, and not in the starving of their land.

As to the size of farms, it will probably vary in the future as it has varied in the past. Large and small holdings have their respective advantages for various purposes and in different localities. In arable districts at least, and so far as the production of the ordinary crops of the farm is concerned, I do not believe that a holding not too extensive to be efficiently superintended by one man can be too large for the most economical

results, provided that he has capital enough for his acreage; or that fifty-acre farmers can get a good living by growing corn and keeping a small number of live stock. In favourable situations for marketing milk, butter, fruit, vegetables, eggs and poultry, small farmers who are shrewd and industrious may do well; and cheese-makers on small holdings have always been able to hold their own, if they and their wives were good and skilful managers. But any experiment in setting small farmers up in business with State funds will be too artificial to succeed.

A good deal might be done by and for farmers to give them a better chance of success than they enjoy at present. Co-operation in buttermaking, and in the purchase of what they require, and the sale of their products, has yet to be tried in this country on an extensive scale and under the best conditions. Railway companies must be induced or compelled to treat farmers fairly, and to encourage traffic which they now handicap. Encouragement, too, should be given to the enterprising investment of capital by tenants by making it more secure than it is at present.

If space were available strong evidence might be cited in support of the opinion that the worst days of agricultural depression are over, and that a gradual, if slow, recovery of prosperity for British agriculture—indeed, for agriculture in the world at large—may be expected. If this anticipation should prove true, there will be even stronger reasons than can be given at present for predicting that the survival in farming will not be the exhausting system now general in America, or the penurious slavery inherent to a peasant proprietary, but that it will be a system of judicious high farming, in accordance with the practice which has made the finest type of British agriculture the best in the world.

WILLIAM E. BEAR.

---

## THE WORK OF ACIDITY IN CHEESE- MAKING.

IF you talk to an intelligent British cheese-maker about the practice of his art, and interrogate him about the conditions which have to be fulfilled in order to carry it on successfully, he is pretty sure, especially if he be of the Cheddar "persuasion," to make "acidity" the burden of his discourse. He has learned by experience that in some way or other—he does not know pre-

cisely how—acidity in cheese-making is the “master of the situation,” and his desire is to capture this untrained creature, to put a bit in its mouth and to harness it to his yoke, so that he may make it draw the product of his cheese-vat quietly and steadily to market instead of upsetting it prematurely into the ditch.

It is a rather singular commentary on this fact that notwithstanding the importance which the British cheese-maker thus attaches to the work of acidity in cheese-making, the literature of the art is extremely poor in information regarding it. Not only do the few text-books in the English language which deal with the theory of cheese-making either ignore the subject altogether or treat it in a meagre and confused manner,<sup>1</sup> but the French and German manuals are almost equally deficient. The comprehensive work of Von Klenze is silent in regard to it, and even the exhaustive treatise of Fleischmann dismisses it with much less consideration than might have been expected.

It may, therefore, not be unprofitable, in the interests of the British cheese-maker, to examine this problem of the influence of acidity in cheese-making, with the view of ascertaining in what it really consists and how far it is capable of being controlled; and the more so as the little that appears to be known about it by practical cheese-makers has been acquired in a purely empirical manner, and, as is commonly the case in such matters, is too often invested by them with an air of mystery which is probably proportionate to the obscurity which exists in their own minds in regard to it.

But, before discussing the work of acidity in cheese-making, it may not be out of place to say a few words as to the source from which acidity in milk is derived, and the influence which it exercises on the composition of the milk; for, unless the cheese-maker has at least a general idea on these points he cannot deal with this condition of milk with the intelligence which is necessary to command success.

In the preceding number of this Journal a description was given (“Acidity in Milk,” page 56) of an appliance by means of which the acidity in milk can not only be recognised but its amount estimated with sufficient precision for the purposes of dairying, and anyone who will provide himself with such an appliance, and will take a little trouble to employ it in examining milk under different conditions, will soon acquire an amount

---

<sup>1</sup> An exception must be made in favour of the great work of Professor Sheldon on Dairy Farming, which, in this, as in most other subjects, is an excellent exponent of the growing knowledge of the period. Nor must the writings of Duclaux be overlooked.

of knowledge on this subject which will enable him, by the aid of a few still more simple appliances, to work out a series of most instructive experiments for himself. But, even without such an appliance for measuring with precision the amount of acidity present in milk and whey, anyone who will procure a few of the blue and red litmus-papers, which may be obtained from any pharmaceutical chemist, may by their aid obtain a good deal of useful knowledge on this matter. Let us see what can be done in this direction.

If we take a sample of perfectly fresh milk from a healthy cow and test it with the litmus-papers referred to above, we shall find that whilst the blue paper is feebly reddened to a purple tint, the red paper is also blued by it to the same hue. This paradoxical effect (technically known as the *amphoteric reaction of milk*) is due to the presence in the milk at the same time of certain alkaline salts (phosphates) which act upon the blue litmus-paper in the same way as free alkalies do, and also, in all probability, to that of a small quantity of free carbonic and lactic acids, the result of fermentative action in the milk which has commenced even in the udder of the cow.

The clearness of the *alkaline* reaction may be increased by boiling the milk, but it gradually disappears as the souring of the milk proceeds.

If we are able to measure the exact acidity of the milk by means of the appliance referred to above, we shall probably find that it is not more than two or three degrees. The alkalinity, on the other hand, cannot be directly measured, unless we can avail ourselves of other resources of the chemist, and its chief importance lies in the proof which it affords that even in perfectly sound milk, at the earliest stage after its separation from the udder of the cow, a certain feeble trace of it is to be discovered by the aid of the reagent which we have employed for the purpose.

If, now, the sample of milk be left to itself and be examined from time to time with both the blue and red litmus-papers, it will be found, as indicated above, that the red litmus-paper gradually ceases to exhibit any change in tint whilst the blue paper becomes redder and redder. By the aid of an acidometer the increase of acidity in the milk can be minutely followed until it reaches from  $15^{\circ}$  to  $20^{\circ}$ , at about which stage, according to the temperature at which it has been kept, spontaneous curding of the milk will take place.

Upon what, it may be asked, does this curding depend? Clearly, in a primary degree, on the increase of acidity. That this is the case may be proved by taking another sample of fresh

milk, raising it to the same temperature as that at which the previous sample had been maintained, and adding sufficient of a solution of *lactic acid*<sup>1</sup> to raise the acidity of the milk to the degree above indicated; curdling will then take place.

As to the exact conditions under which the curd is formed, it will be sufficient here to say that it is produced by the separation in a compact and insoluble form of a constituent (*casein*) which had previously existed in the milk in a state of what may be called diffuse fluidity; a state, if not of actual solution, of diffusion which closely approaches to it, and which may be nearly compared with that produced by dissolving a small quantity of gelatin in a rather larger amount of water. If we make such a solution we shall find that the fluidity of the water is not appreciably affected; but by treating the solution with certain well-known chemical agents the gelatin can be curdled or rendered insoluble, precisely in the same way as the casein has been in the milk under observation. In the case of the gelatin the curd so formed appears in the condition of scattered flocks, just as that of milk does if the milk be kept stirred at the time when it is coagulating. But, if the gelatin be dissolved in the water in larger quantity, by the aid of heat, and the solution be allowed to cool, it then, as is well known, *gelatinises*—*i.e.* separates in a peculiar condition, intermediate between solidity and fluidity, in which the whole of the water is retained in a state of intimate union with it.

The union, indeed, in which the gelatin is thus combined with the water is so intimate that it cannot be separated from it except by drying. The jelly when once formed in this condition, which can only be done by lowering the temperature of the warm solution in the way described, has no property of contractility by which it can free itself of the water with which it is united. This is a very important point to bear in mind, because, as we shall see, it essentially distinguishes the jelly or curd of gelatin from the corresponding jelly or curd of casein.

To appreciate this distinction it is only necessary to raise the temperature of the curdled milk to about 90° F. and to observe what takes place in it. This observation will be much facilitated by scoring it across vertically, at right angles, so as to divide it into cubic columns resting on the bottom of the vessel, just as is done in cheese-making, and by also running the knife around the margin of the curd, so as to separate the latter from the surface of the vessel. On doing this we shall soon see

---

<sup>1</sup> This acid may be obtained of any pharmaceutical chemist. It is generally supplied of such a strength that it will require considerable dilution with water to adapt it for such experiments as those described in this paper.

the rifts in the curd made by the knife gradually widening and the clear whey appearing between the blocks of curd thus rendered apparent. This will go on, so long as the temperature of the mass is maintained, until the curd, which is at first soft, compressible, and easily broken up, becomes firm, resistant, and possessed of a considerable degree of cohesiveness or *tenacity*.

Now, just as it was evident that the formation of the curd was originally due to the presence in the milk of a certain degree of acidity, so it is equally clear that the casein of which it is composed possesses at the time of separating from the milk a certain amount of *spontaneous contractility*, in virtue of which it is able gradually to contract on itself, and in so doing to squeeze out the liquid whey. This power of spontaneous contraction which the curd possesses is the very foundation of cheese-making, and unless it be thoroughly recognised by the cheese-maker, and the conditions under which it can be maintained be clearly appreciated, it is impossible for him to acquire an intelligent acquaintance with the principles of his art.

The interest of the phenomenon is the greater because it is probably the best illustration which we possess of the lowest grade of organisation. In this respect, the jelly of casein, which we have already compared with the jelly of common gelatin, and have distinguished from it by the possession of this property of spontaneous contractility, may be compared, on the other hand, with another kind of jelly—viz., that of the clot which blood forms outside the vessels in which it circulates in the living body, or, after a certain time, inside them, when the body cools after death. This coagulation of the blood is caused by the gelatinisation of a body (*fibrin*) closely allied to casein in its ultimate composition, but differing from it in possessing a still higher degree of self-organising power. Into the very interesting problems of the relations exhibited by these three bodies—gelatin, casein, and fibrin—to one another, it would be out of place to enter here; they have only been thus incidentally referred to in order to impress upon the cheese-maker's mind the fact of the spontaneous contractility of the curd, and to afford illustrations which may enable him to appreciate the mechanism of the process by which the curd gradually assumes the form which he seeks to give it with the view of ultimately converting it into cheese.

In each case the jelly must be looked on in the light of a *sponge* of gelatinous material, in the interstices of which are at first retained not only the water in which the spongy fabric itself was originally dissolved, but also any matters which have, in common with the gelatinous material, been in solution in it,

as well as any others, such as, in the case of milk, the fat-globules and certain mineral constituents (earthy phosphates) which have been merely suspended in it in a state of minute division. In the case of the gelatin, this sponge is possessed of no contractility whatever, and the effect of heat on it is merely to resolve it again into a state of fluidity. But, in that of the milk jelly, when once this sponge has been organised it goes on slowly contracting and squeezing out the liquid whey from its interstices, whilst retaining in them the fatty and mineral matters, and in so doing it passes into the condition of firm, tenacious curd.

Let us now, whilst the curd is thus being organised in our sample of soured milk, take a second sample of fresh milk, of about the same degree of acidity as the first, and, after raising it to a temperature of about 90° F., mix it with enough<sup>1</sup> solution of rennet to coagulate it in about half-an-hour. We shall then obtain a jelly which, in its general appearance, is indistinguishable from that formed spontaneously in the soured milk, and which, if divided in the same way as was done with the latter, will be found to exhibit the property of spontaneous contractility as that did.

So far as we have yet gone, therefore, it is evident that the primary work of the rennet is to effect the coagulation of the casein of the milk in the same way as acidity did, and that it will do this in the presence of only a feeble degree of acid.

Let us now carry the experiment a stage farther, and, taking a third sample of fresh milk, add carefully to it, stirring the while, enough of an alkaline solution (that formed by dissolving a few crystals of common washing-soda in a teacupful of rainwater will answer the purpose) to neutralise any acidity that may be present—that is, until the milk produces no effect on *blue* litmus-paper or gives a permanent purple tint with a drop or two of the *indicator* solution (see p. 59) of the acidometric test. If now the milk, thus slightly alkalinised, be treated with solution of rennet, under the same conditions as those under which the fresh milk was renneted, it will be found that it also will in time coagulate, but that it will take much longer to do so, the actual length of time required varying with the degree of alkalinity of the milk. Moreover, when the curd has formed it will be seen to differ materially from that of the untreated milk in its want of cohesion, breaking up when touched into separate

---

<sup>1</sup> The exact amount necessary for the purpose will depend upon the quantity of milk and the strength of rennet employed. One drop of rennet to half-a-pint of milk will do for a *rough* approximation, which may be modified according to the result of experiment.



flocks. It has, in fact, all the characteristics of what is called a flocculent curd, and if any attempt is made to separate it from the whey, the latter will become turbid from the minute fragments of curd which will separate with it, forming the "white whey" which is so familiar to cheese-makers with a defective curd in the milk-vat.

It will thus be seen that whilst the presence of acidity in milk is not *essential* to enable rennet to exercise the peculiar power which it possesses of coagulating it, a certain amount of acidity in the milk when the rennet is added to it gives to the curd a degree of tenacity which renders it firm and enables it to be handled without loss of any material portion of its structure in the whey.

We have already noted that, in the case both of the milk coagulated spontaneously by souring, and in that coagulated by rennet in the presence of a small degree of acidity, the curd possesses the power of spontaneous contractility (which is really an indication of *elasticity*); but if we compare with it in this respect the curd of the alkalisied milk, we shall find that the contractility of the latter is very feeble. Instead of the rifts produced by the knife steadily widening, and the blocks of curd as steadily contracting, the curd remains an inert mass, which does in time show some slight amount of contractility, but not enough to give it anything like the firmness of the other samples, or to free it from the whey, as has occurred with them.

The indication thus afforded of the effect of a small amount of acidity in communicating elasticity and tenacity to the curd formed in milk by rennet may be still further illustrated by taking yet another sample of fresh milk and adding to it enough of a solution of lactic acid (the acid produced in milk spontaneously during souring) to give it from ten to twelve degrees of acidity, as determined by the acidometer. If the milk thus artificially soured be treated with comparatively the same quantity of rennet used in the previous experiments, and under the same conditions of temperature, &c., it will be seen to coagulate in a much shorter time than before; and if the curd be sliced, as before, the readiness with which the blocks will contract, and the comparative firmness which they will present when handled, will give proof of a high degree both of elasticity and tenacity.

From this short series of experiments, which are so simple that any person of ordinary intelligence can perform them with the aid of a few cups or basins, of solutions of soda and lactic acid, and of common litmus-papers (if an acidometer be not available), it is easy to learn in a thoroughly practical way what

are the primary effects of acidity and of its excess or deficiency on the curd produced in milk by rennet. From the results thus obtained it is not difficult to form a general idea of what will be the secondary or remote effect of the three conditions on the curd when it comes to be separated from the whey and to be handled as it requires to be in order to convert it into a compact cheese. But the practical working-out of this problem is scarcely more difficult than the experiments which we have already described. All that is necessary is to take quantities of milk which are sufficient to give such an amount of curd as can be conveniently handled<sup>1</sup>; to drain the whey off the curd after the latter has been gradually reduced to small fragments by cutting or breaking with the fingers; to then press these fragments into any convenient mould, so as to weld them into a uniform mass, and, in fact, to treat the samples of curd generally in the way in which curd is dealt with in making any ordinary type of hard cheese. One point in this after-treatment is essential in order to produce results which shall be comparable with one another and with those obtained in ordinary cheese-making, and this is that the curd shall in each case be maintained as nearly as possible at a uniform temperature, commencing at about 90° F. and falling gradually to about 65° F., at which temperature the compacted cheese should be maintained as long as is practicable.<sup>2</sup>

Let us now assume that we have converted the curd of the four samples of milk, treated as first described, into four cheeses; that we have handled these miniature cheeses in the way in which larger ones would be treated after they are taken from the cheese-vat or mould; and that we have kept them sufficiently long to allow of their undergoing those fermentative changes in which the process of ripening consists: what will be the differences, if any, which we shall observe in them?

To take first the curd obtained from the spontaneously soured milk: we shall find, at the outset, that it will have so low a degree of tenacity that it will be difficult to get it to cohere into a compact cheese at all. If we succeed in doing so, the cheese

---

<sup>1</sup> One gallon of milk is ample for this purpose in each case, and less can be made to do with a little practice.

<sup>2</sup> It has not been thought necessary to give precise instructions here as to the treatment of the curd in this series of experiments, as anyone with even a slight acquaintance with practical cheese-making will be able to judge from his own experience how to proceed. A hot-air chamber sufficient for the purposes of the experiments above suggested can be constructed out of an old biscuit tin, in which two or three holes are made as inlets and outlets of the products of combustion of a small benzoline lamp and for the introduction of a thermometer.

as it dries will become so brittle that it can scarcely be handled without some of it crumbling away. As time passes it will get drier and harder, until eventually it will break up into a number of hard, tough fragments, without either the characteristic odour or flavour of cheese, and which appreciative mites will ultimately resolve into appropriate dust. If we compare with this result that obtained from the slightly alkalisied milk, we shall observe, on the other hand, that, as has been before indicated, the contraction of the curd is so feeble that it is impossible to free it from the whey, even in a very imperfect degree, without losing a considerable portion of it in the whey, and that when we have got it into the mould it forms a sodden mass which no amount of pressure will consolidate into the consistence of a proper cheese, except at the expense of a great loss of "white whey." If the cheese so formed be kept at a high temperature (over 65° F.), it will gradually exhibit evidences of putrefactive decomposition. Gaseous products will form in it, which will distend it in one direction or another, and will ultimately cause it to burst. Either in the whole or in parts it will soften until it may become perfectly fluid. The small amount of the genuine flavour and odour of cheese which it may acquire will soon be replaced by the offensive products of putridity; and the cheese will end by becoming the congenial breeding-ground of maggots.

Such, in brief, is the contrast which the cheese made under the two opposite conditions of excess and defect of acidity exhibits. The two intermediate samples—viz., that made from ordinary fresh milk and that from milk the acidity of which has been artificially increased at the time of renneting—display, as might be expected, gradations of character which correspond to the amount of acidity present in them at the curding stage. In the first of them we shall have a product which approaches the character of a sound, well-flavoured cheese in proportion as it has been made in other respects properly. But however properly in such respects the second of these two cheeses may have been made, the vice implanted in it by the excess of acidity present at the outset will make itself more or less apparent afterwards throughout its history. It may not be as dry or as crumbly or as tasteless as the cheese which was made from the spontaneously soured milk was, but it will approach these characteristics in proportion as its acidity rises beyond the amount required to give just that degree of tenacity and elasticity to the curd which will enable it to expel all the whey but what is wanted to promote those fermentative changes on which the ripening of the cheese depends.

From all of these facts it follows that the curding of milk by rennet as practised in cheese-making is by no means a simple phenomenon. We will dismiss from our consideration here the effect on the process of variation of temperature and of variation in the character of the casein itself (dependent on variation of food, period of lactation, &c.), and will confine our attention exclusively to the relations which exist between the rennet and acidity. It is obvious that, so far as the mere coagulation of the casein is concerned, these two agents are capable of replacing one another, but in each case the curd obtained will differ materially both in its primary and in its secondary characteristics. By using excess of rennet we may, it is true, develop a considerable contractile power in the curd, but then the secondary effects of such an excess in promoting premature decomposition render its employment for that purpose fatal to the keeping quality of the cheese. Hence the need of a certain amount of acid to co-operate with the rennet and to give the curd a firmness which it would not otherwise possess.

The contractility which the curd exhibits in its earlier stages is easily destroyed, depending as it does on the maintenance of a proper degree of warmth. If the curd is chilled, and in proportion as it is so, its contractility will be paralysed, the whey being retained in it in a degree which will defy all the powers of the press to extract it, and then good-bye to any prospect of making a sound cheese.

It is often asserted that it is during the development of acidity in the whey, before the latter has been drained from the curd, that the most important influence of this agent is produced. But this is a mistake. For, if the acidity of the whey be tested whilst it is in the vat, it will be found to increase very slightly, if at all, during the time for which it is safe to leave it there. The error has arisen from mistaking the effect of the *heat* of the whey for that of its *acidity*. It is after the whey has been lifted from the curd, and the latter has been exposed to the combined effect of heat and air, that its acidity increases so rapidly.

Reference may here be made to a rather paradoxical fact connected with the development of acidity in milk, which may be noted in making the experiments described above. If, after the curd has been formed in each of the samples of renneted-milk (assuming that they have been meanwhile kept at a suitable temperature), we test them at intervals we shall find that the acidity in the whey of the sample that had been artificially soured at starting, though greater by several degrees than it was at the outset, is not appreciably more (and may

in some cases be even less) than that of the untreated milk; whilst the whey of the milk which was alkalisied may be the most acid of all. But, notwithstanding the curious change which has thus taken place in the relations of the three samples of whey in this respect, those of the curds are not apparently altered. The curd of the alkaline milk is still soft and incoherent, although its whey is now of so high a degree of acidity, whilst that of the acidified milk is still tougher than that of the others although they have overtaken it in the race of acidity.

This somewhat paradoxical fact shows conclusively that it is at the earliest stage of its formation that the permanent character of the curd is impressed upon it, and that it is at this stage also that acidity produces its special effect in modifying the peculiar action of rennet. It is true that the defect arising from deficiency of acidity at the renneting stage may to some extent be corrected by encouraging the development of acidity at a later one (that of draining, after the whey has been removed); but the error caused by excess of acidity at starting can never be effectually rectified afterwards, and the only remedy for it is to push on the ripening and marketing of the cheese as rapidly as possible.

In addition to the effect which acidity thus produces in modifying the tenacity of the curd developed by the special action of rennet, it exercises two other actions in cheese-making which are of considerable importance.

In the experiment described above we have indicated the effect of insufficient acidity as it may be shown in sound milk the natural acidity of which has been artificially neutralised by the addition to it of a certain amount of alkali. But this condition of deficient acidity may, under certain circumstances, be met with naturally in milk, and when this is the case its effect in cheese-making is most pernicious. And the reason is simply this: the absence of a certain degree of acidity—still more the presence of marked alkalinity—in fresh milk is in the great majority of cases, if not in all cases, a symptom of disease, either local or general, in the cow from which the milk has been taken, for it is caused by excess of alkaline phosphates in the milk, and this is, in its turn, due to excessive tissue-waste. Now, alkalinity in a highly organised fluid like milk is a most favourable condition for the development in it of the germs which bring about putrefactive decomposition, even if those germs are not already present in it as the result of disease.<sup>1</sup> Hence such milk exhibits, when treated with rennet, during the curding stage, unmistakable evidence of

---

<sup>1</sup> Much light has been thrown on this subject by the researches of Duclaux, a full account of which will be found in the monograph *Le Lait* (Paris, 1887: J. B. Baillière et fils. Pp. 336. 3fr. 50c.).

the commencement of decomposition in the evolution of gas. This gas, unlike that developed by the natural fermentation of the sugar of the milk (carbonic acid gas), is insoluble in the watery constituent of the milk, and therefore makes itself evident as bubbles. A certain quantity may escape to the surface of the milk during the stage of curdling, but the bulk will remain imprisoned in the curd, and may even so affect its specific gravity that instead of sinking in the whey when free to move in it, as sound curd should do, it will rise to the surface of the whey, forming the "floating curd" with which so many indifferent cheese-makers are familiar, and which has been the *bête noire* of so many cheese-factories, especially in America. Professor Sheldon suggests that it was in consequence of the trouble experienced in the earlier American cheese-factories from this cause that the attention of American dairymen was directed to the value of acidity in correcting it. This was very probably the case, for it is not only in America but in this country also that the effect of artificially developing acidity in milk which is suspected to be unsound has been empirically discovered to be a corrective, and various agents have been employed for the purpose of creating it. In some cases the result is brought about by the addition to the milk, before it is renneted, of a certain amount of sour whey, the action of which is to inoculate it with a special dose of the ferment by which acidity is developed. In others the addition of an acid, such as lactic acid (the natural acid of the milk), or an acid salt, such as the acid phosphate of lime or alum, has been employed with equally useful effect and without the risk, attendant on the employment of sour whey, of introducing with the acid-producing germs others which may exist in the whey with them, and which would give rise to special sources of mischief during the ripening stage.

But probably the least objectionable method of neutralising the defect in question is to keep the milk in the vat at the renneting temperature sufficiently long to raise the acidity to the required point before renneting it, taking care, of course, that it is well stirred meanwhile, so as to prevent the cream rising. The next best remedy is to push on the acidification of the curd during the draining stage, by cutting it up well and piling it often, so as to expose it freely to the air, at the same time *keeping it warm*. In either of these ways the mischievous effect of deficient acidity in the milk may be more or less perfectly remedied, for the development of acidity arrests the multiplication of the special germs which flourish in neutral or alkaline milk, and the growth of which is attended not only by the evolution of the gases of putrefaction, as above indicated, but by modifi-

cations of the butter-fat of the cheese which destroy its proper aroma and flavour, and substitute more or less offensive ones for them.

The second effect of acidity in cheese-making alluded to above, but to which it is only possible to make a passing reference here, is the influence which it exerts in favouring the development of the *mould* on which the successful manufacture of soft cheese of the Camembert type, or of semi-hard cheese of the Stilton and Gorgonzola type, depend. A certain degree of acidity appears to be highly conducive, if not essential, to the growth of the fungus (*Penicillium*) of which this mould consists, and which probably flourishes at the expense of the acid. Hence in both of these types of cheese, whether the mould grows outside the cheese or inside it, its production is favoured by not checking the acidity too much by salting or by cooling of the cheese in its earlier stages.

The general outline of the work of acidity in cheese-making which has been thus given, with an incompleteness of detail for which the unavoidable limitation of space must be some apology, will, it is hoped, at least offer a clue to the intelligent cheese-maker by which he will be enabled to work out for himself the rules that are necessary to enable him to avail himself of it for his own practical purposes. Two conditions only are essential to his doing this: the first is that he shall possess some appliance for measuring acidity; and the second is that he shall take some little trouble to learn how to use it properly. With such an appliance at his command and with a few ordinary vessels, such as teacups or breakfast-cups, for holding samples of milk, small quantities of solutions of rennet and of lactic acid, and a chamber of any kind in which the temperature can be maintained at from 80° to 100° F., he may without difficulty institute a series of experiments similar to those described above, by which he will soon learn more than he would by reading pages of written description. He may in this way study for himself the relative effects not only of acidity, but of rennet and of temperature, on the formation of the curd; and it is not too much to say that unless he will do this he will never become a truly intelligent cheese-maker: for it is only in this way that he can disentangle the complex problem which is presented by the combined action of these three agencies on the casein of milk.

FRANCIS T. BOND.

---

## EXPERIENCES OF THE SEVERE WINTER OF 1890-91.

IN order to place more clearly before the reader the influence of rainfall and temperature upon the produce of the soil and the health of the live stock of the farm, it is necessary to take a retrospective view of a cycle of years, for which purpose we have selected the period 1885-90. Although the mean rainfall varies considerably in different localities, yet taking the average of the last six years the deficiency throughout the whole of England is very slight. During the winter of 1890 and the spring of 1891, the springs have, in many localities, been nearly as low as they were in the dry summers of 1868 and 1870. In some districts the only supply for the stock of the farm was carried in water-carts from available points, often at some distance from the homestead.

I have in my own practice spent considerable sums in conveying water by gravitation, and in raising it by motive power, for the supply of homesteads and cottages. My experience, which coincides with the opinion entertained by other observers, is that the general extension of drainage is exercising a disturbing effect on the springs by carrying off the surface water more rapidly, and thus preventing its percolation through the soil to supply the deep wells and subterranean circulation. If this contention be correct it is obvious that the rapid removal of the surface water will reduce evaporation, and slowly decrease the amount of rainfall. Medical men are aware of the fact that certain diseases are more prevalent in a wet than in a dry season, though the latter is more fertile in its own special maladies. The same influences affect the health of the lower animals, to which we shall refer as we proceed.

During the period under consideration, farmers have sustained large losses of stock due to causes of a preventable character. The season has, on the whole, been peculiar. South of the Trent the temperature was more variable, and on the average more severe, and the snowfall much heavier, than was experienced in counties in the more northern parts of the kingdom. In some of the south-western districts of Scotland the plough was idle for little more than three weeks throughout the whole winter. In many of the eastern and southern counties of England the snow lay long and deep for many weeks. So late as the second week of March the southern and south-western counties were visited by one of the heaviest falls of snow



on record. On the 10th, 11th, and 12th of the month, snow continued to fall uninterruptedly, accompanied by a violent gale that caused great damage to shipping in the Channel and along the south-west coast. The traffic, both on road and rail, was entirely suspended; trains were blocked in snowdrifts, and were unable either to proceed on their journey or retrace their course, thereby causing great suffering, and in some instances even loss of life. The stock of the farm, where exposed to the elements, were caught in the drifts, which in places were fifteen to twenty feet deep; the sheep could not be extricated for several days, and on many farms the losses were heavy. Whilst the inhabitants of the West were experiencing all the rigours of an Arctic climate, we in the Midlands were comparatively free from snow. It was only on the elevated ranges of North Staffordshire and of the Peak districts of Derbyshire that snow was to be seen. During spring and early summer our river valleys suffer far more from late frosts than do the more elevated districts.

Where cattle were subjected to the test of the weighing machine during the spring of 1890, the price of the best class of stores per 100 lb. live weight was relatively higher than the price realised per 100 lb. for prime fat cattle of the same class and quality. Owing to the scarcity of keep and the backward state of the pastures, in April, 1891, store cattle were about 8 per. cent lower in value than they were at the same date in the previous year. At the time of writing store and fat cattle are worth the same price, a fraction under 4*d.* per lb. live weight, which shows pretty clearly the unfortunate position of the grazier who has to purchase his stock at spring. On mixed occupations, where breeding and rearing can be successfully carried on, the farmer is in a much better position. On all but the best fattening pastures this system is capable of considerable extension. In some districts the want of suitable buildings for the accommodation of the young stock hampers the tenant and retards the progress of breeding. This deficiency can be supplied by inexpensive structures, fulfilling all the economical requirements as regards labour, and maintaining the healthy condition of the animals, at a small cost compared with the usual erections of bricks and mortar and slated roofs. The sheds can be made equally comfortable at less than half the usual cost.

When the lands that have been abandoned are again brought into cultivation, and large areas that have been laid down to permanent pasture during the last ten years are again brought

under tillage, though in many cases they are not adapted to the growth of the finer cereals, they are nevertheless capable of adding considerably to the output both of milk and meat. This certainly would result under a system of co-operative dairying, where the separated milk is utilised for the raising of stock on the farm, and the cream is conveyed to a central depot, where it is made into butter or otherwise profitably utilised.

There is little complaint to be made as to the price at which good beef has been selling throughout the year, as 7*d.* to 7½*d.* per lb. is a fair price, though formerly 5*s.* per stone (of 8lb.) was considered a good price. What the grazier is suffering from is the high price of stores. We do not remember a period when the graziers of the Midland Counties were so heavily hit as they were in the season of 1890. Although there has been a considerable drop in rents, this did not save the tenants of feeding land from incurring serious losses.

Rearing has been extensively carried on during the last two or three years, so that hopes were entertained that the prices of stores would recede as stock became more plentiful; but at present there is no prospect of this hope being realised. Those who rear, aided by the low prices of auxiliary foods, have been finishing off all the best animals at an early age, and it is only the inferior or cull animals that reach the markets as stores. This is clearly apparent in all our markets in the inferior quality of the stock on offer.

The hay crop of 1890, though an average as to bulk, was, with the exception of the small quantity secured before June 20, generally of inferior quality. Much damage was done, owing to the unsettled state of the weather during the latter part of June, and throughout a great part of July. When the fine weather did set in the crops were over ripe, the seeds had been shed, and the culms had assumed a woody condition. The corn harvest, on the other hand, was secured in good condition, and the straw was of prime quality. There was in reserve an unusually large quantity of good hay, the produce of 1889. The long severe winter of 1890-91, followed by a late spring, made heavy demands upon the fodder; nevertheless the prices remain moderate. On most stock farms, the more extensive use of meals, and other artificial auxiliaries, in combination with chaffed hay and straw, prevents waste, and effects a general economy in the consumption of fodder. On some farms the litter is cut into chaff, whilst, on others, moss litter is to a certain extent replacing straw.

The root crop was an average. The experience of the mild

winter of 1889-90, still fresh in the memory of most farmers, and the great difficulty in obtaining labour in many districts, were the chief causes why the crop was not secured at the usual time. On most farms, however, the mangel crop was saved. Throughout the length and breadth of the land the swede, common turnip, and cabbage crops were, on the other hand, almost completely destroyed, the only exception being the later sown swedes. These, where drilled on the flat, took a deeper hold of the soil; hence they stood the severe weather better. Cabbages, though producing a large quantity of food, are not well adapted for winter use, being equally susceptible both to rains and to frost. During the spring of 1890 swedes were plentiful; late in March large quantities of sound roots were waiting to be eaten off free of cost on the dry soils of the East Riding of Yorkshire, whereas this year at the same date there was not a healthy root to be seen. On sound turnip land, where the crop is fed off on the ground, sheep will do as well up to the end of November or even to Christmas on soft turnips as they will on swedes, with a considerable saving in the labour bill by allowing the sheep to gnaw the roots on the ground instead of passing them through the turnip cutter.

Roots are no exception to the general principles which govern plant-growth. They attain maturity, ripen and decay. In order to prevent, or at all events to retard, the last-named contingency, they should be taken up and stored; otherwise, if left in the ground exposed to atmospheric changes, their feeding qualities deteriorate. The swede crop should be harvested early, and, if possible, during fine weather; the roots keep best when placed in small heaps of not more than two cartloads each. A moderate covering of earth is sufficient to protect them during the severest weather, provided they are not exposed to the air whilst in a frozen state. The practice more generally obtains of cutting off the end of the root with a sharp knife, and severing the leaves from the crown. If for storage in the field, in order to be cut and placed in the troughs for the fattening sheep during the winter or spring, the system is wasteful. The leaves should be severed so as not to wound the crown of the root, and the soil should be shaken off without cutting off the ends of the roots. By this means all waste from the exudation of juice is avoided. The roots are carefully cleaned as required for use, and they are found to be more crisp and nutritious, and hence more palatable and better relished by the stock.

The mild open winter of 1889-90, accompanied by heavy root crops and an over-average crop of hay, carried stock through

with a lighter requisition on the hayricks than is generally the case; hence a larger quantity of old hay of good quality was left over with which to begin the winter of 1890-91. The abundant and well-saved straw crop of 1890 was profitably utilised as prepared food, instead of, as formerly, trampled into manure in open yards. Another great advantage to the stock farmer was the low price of cereals and other auxiliary foods. The loss of the turnip crop caused to be sent to the butcher many young animals in forward condition which under ordinary circumstances would have been kept for two or three months longer, thereby not only increasing the output of meat but adding to the profits of the farmer. The depressed times have taught men the value of economy, and the more general practice which now obtains on the best farms of preparing the fodder and other foods is resulting in greater economy, so that in April there was still on most farms a fair quantity of the hay crop of 1890, though generally of inferior quality. The most conclusive argument as to the stocks is the rate of prices in the market; the best quality of hay has reached, but not exceeded, 4*l.* per ton delivered.

The use of meals and other feeding stuffs is still on the increase. Many cases have come under my notice where a yearly outlay of 40*s.* to 50*s.* per acre over the gross acreage of the farm was incurred during the cycle of low prices. Even on mixed farms, on the average an extra outlay of 15*s.* per acre has been made on the purchase of artificial foods. We do not recollect a more protracted or severe winter, lasting as it did without intermission to the end of April, and yet we have often seen the stock of the dairy districts in much lower condition at May Day.

It will probably interest the reader to place before him a detailed account of the management of a farm of 586 acres, only 24 acres of which are now in tillage, part of the old pastures being second-rate feeding land, and the remainder of the old pastures good store land: 117 acres have been laid down since 1885. The cropping for 1890 was 10 acres cereals and 14 acres mangel and cabbage, whilst 130 acres of grass land were mown. The number of stock on the farm during the winter of 1890-91 was 270 head of cattle of all ages. The hay and straw are chaffed, and the chaff is mixed with meals, pulped roots, and silage. Moss litter and uneatable straw alone are used as bedding. All cattle are tied up, excepting calves. The tillage land is strong, so the farmyard manure is applied to the land for the root crop. During the autumn the winter-made manure is applied as made to the young grass and poor pastures. In addition to a liberal

dressing of farmyard manure,  $1\frac{1}{2}$  cwt. of nitrate of soda and 3 cwt. superphosphate are applied per acre for the root crop. Four work horses are kept, besides four or five well-bred Shire mares for breeding purposes; also a variable number of young Shires of different ages.

A flock of 260 breeding ewes is maintained, in addition to which 220 tegs have been wintered. The ewes are of no special breed, the object being to obtain the greatest possible number of lambs. The prolificacy and milking capabilities of the ewes are considered in order that a large proportion of the young stock may be fit to go as fat lamb; about half the yearly produce, say 200, are sold off the ewes direct to the butcher. The yearly outlay on cake and other purchased foods is 960*l.*, and the artificial manure bill is 130*l.* Forty calves a year are reared, some of which are bred on the farm and the remainder purchased.

In addition to the stock reared on the farm, barren cows and heifers are chiefly fattened on the best pastures. On the best store land a good class of lying-off cows and heifers, picked up in the dairy districts, are sold to the London dealers when due to calve. Others are bulled on the farm, a well-bred bull being kept for the purpose. As a natural consequence, these latter remain longer on hand, care being taken that they shall calve at a time when milk is likely to be most wanted. By arranging that they shall come in at the right time, a difference of several pounds per head in their value often results. The labour bill amounts to 17*s.*  $2\frac{1}{2}$ *d.* per acre.

The farm is in the hands of a yearly tenant, subject to one year's notice to quit. I need scarcely say that the tenant is a thoroughly practical man, possessed of ample capital, and the management of the farm is in every way highly creditable to the skill and general intelligence of the occupier.

There has been no apparent scarcity of milk during the winter. All milk-selling farmers contract for the year at separate prices for the winter and the summer six months. Half the summer quantity must be furnished during the winter, otherwise the farmer renders himself liable for damages. With rare exceptions the stated quantities have been maintained; there has been very little demand for accommodation milk, and this has been met by the factories at an enhanced price, the only falling off having been during the latter part of April. I have never known so large a number of cross-bulled cows—that is, cows served to come in for the winter dairy. Farmers in the Midlands use brewers' grains largely for their dairy cows

during the winter. Mangel, where obtainable, and maize and rice meal, are favourite foods. These increase the quantity at the expense of quality, which gives rise to frequent complaints from the purchasers, who charge the farmer with watering, though he is innocent of the offence. A mixture of peas, oats, and linseed ground together, mixed with chaff, and macerated with hot water, is the best food, and roots should be used sparingly. A liberal supply of pure water at an even temperature is essential.

The sheds should be roomy and well ventilated. No single shed should be less than 18 feet wide inside the walls. Where practicable we prefer double sheds, with a central feeding passage. The mangers are made of fire-clay glazed inside. The sheds should be well lighted and ventilated, and the cold air should be admitted at the floor level, with a free exit for the heated air at the apex of the roof. No under-ground drain is admissible in a cowshed, the liquid drainage, if any, being conveyed in an open channel, and delivered into a trapped drain well outside the buildings. All floors are composed of concrete, finished on the top with a thin coating of fine stuff, and notched to prevent slipping. The best litter is peat moss; a layer six or eight inches deep is spread over the whole of the floor, a sprinkling of four-inch cut straw is scattered over the beds, and there results one of the most healthy, comfortable, and, as to the economical conservancy of the manure, most perfect sheds it is possible to make. The droppings are collected from time to time and removed, whilst the peat absorbs and preserves the urine and its valuable constituents. When the moss litter has become thoroughly saturated, it is carried out, and may be taken direct to the land, its place being supplied by a fresh dressing.

As already noticed, there was no scarcity of milk during the winter months, so that, though the demand was better, prices were not sensibly affected. Separated milk is being more appreciated, and the demand steadily increases, both in the towns and the rural villages. In some districts the owners of butter factories are delivering fresh separated milk at the doors of the working classes daily at one penny per quart. Thousands are now enjoying the luxury of a regular supply of milk, where, though situated in country districts, milk could not be formerly obtained except at prohibitive prices. Good cheese has been in demand and has realised satisfactory prices; both farmers and factors are bare of stock, and as the early make is likely to be light, the general opinion is that prices will harden. As to butter, we need never expect to compete with the foreign pro-

ducer except we adopt his methods. We have the best raw material in the world, and yet we are urged to persistently follow an unprofitable system ending in loss and disgust. Were the English dairy farmers to co-operate and produce butter in quantity, they are in a position to command the best market prices of the day. The demand for the highest quality of fresh butter is limited; only the best hotels and private families will pay the price. For first-class powdered or slightly salted butter, the demand is practically unlimited; if farmers would combine together and, instead of cultivating a fresh butter trade, would lightly salt and tub the butter on the Normandy principle, and dispatch it to market daily, it would at once take the place of the Danish and Normandy produce, and when well made it would excel either of these in quality. The Normandy butter is the produce of small holdings; the butter is churned at home, and is sent to a factory where it is graded and packed for market. Butter made in this way is never equal to that made from new milk, mixed and passed through the separator, churned and packed on the spot.

I am well acquainted with three leading Dairy Counties, and in my wanderings visit the butter markets whenever an opportunity offers. During the last three weeks of April, farmers' butter was selling at from 10*d.* to 1*s.* per pound, and in many country markets a pound means eighteen ounces. Many of the sellers sit in the market for hours, waiting for the customer who never comes; the old hands have a few regular customers, who pay their shilling and go. Even at the lower price it is not unusual for a considerable quantity to remain unsold at the end of the day. What a contrast with the cheese and butter shop round the corner! Here they are busy all day supplying the country people with Norman and Danish butter at 1*s.* 2*d.* to 1*s.* 3*d.* per pound of 16 ounces. The Co-operative Stores in a large town well known to me take 800 to 1,200 lb. per week from a factory five miles distant, instead of supplying their wants from the butter market not more than a hundred yards from their own door, and at a price for the factory butter from 3*d.* to 4*d.* per lb. above the current price in the market.

It is said butter making does not pay, nor is it likely to do so whilst made in the farmhouse. We want the light of science to illuminate the dark path of farmhouse dairy management. According to the recent utterances of some of our advanced teachers, they are still guided as to the development of the acidity of cream by taste and smell, whilst the acidity of the

curd is ascertained by the application of the red-hot poker. This leads the mind back to the days of Jesse Williams, the father of the factory system, and can scarcely be accepted as complimentary to the intelligence of the last decade of the nineteenth century. Let the landlords and tenant farmers, who are equally interested, band themselves together, erect and equip factories, and thus lay the foundation of an industry that will alike benefit the interests of agriculture and of the nation. Last year a Limited Liability Butter Factory, of which I am a director, handled about half a million gallons of milk; this year we are considerably increasing the quantity. We have now an established trade, and are well satisfied with the results. At a recent meeting an offer was placed before us from a London firm, doing a large family trade, for a given quantity per day for a fixed period at an advance of 1*d.* per lb. on the price of the best Jersey. This we declined to accept, as we can place all we make at more money. A retailer who supplies families has been making 1*s.* 8*d.* per lb. for factory butter during the winter months.

The contract prices of milk during the season of 1890-91 were practically the same as they have been for the last two or three years—1*s.* 2*d.* per barn gallon of 17 imperial pints for the six summer months, and 1*s.* 7*d.* per barn gallon for the six winter months, the farmer paying carriage. For a week or two at about Christmas time accommodation milk made 2*s.* 6*d.* per dozen of three imperial gallons, this being the measure by which milk is purchased for the Manchester market. The finest factory butter made from 1*s.* 4*d.* to 1*s.* 6*d.* per lb. wholesale, and retailers having a good family trade charged their regular customers 1*s.* 8*d.* per lb. Best Derbyshire cheese made from 52*s.* to 65*s.* per cwt. of 120 lb.; fine Cheshire made rather more money.

The lambing season in the Southern Counties, which is fully two months earlier than generally obtains in the Midlands, was successful. There was a full average crop of strong, healthy lambs, and less than the usual mortality amongst the ewes. Owing to the nearly total destruction of the root crops, and the backward state of the forage and seed crops, the breeding flocks have been with difficulty, and at great cost, carried through the trying season. The crops that best withstood the severity of the winter were the different varieties of kale. Where these crops were late-sown, and the kale seed was mixed with common green-top turnip, it is remarkable how the latter resisted the frost. This was, to some extent, due to the protection given by the kale.



Throughout the grass counties the crop of lambs was under the average, and the mortality amongst both ewes and lambs has been heavy. On many farms during the sharp weather the ewes suffered from want of a sufficient allowance of nutritive food. A foddering of poor hay once or twice a day, whilst the land was covered with snow, was totally insufficient to maintain their condition, hence as the lambing season approached the ewes were found to be weak and low in condition, whilst their milk was scanty in quantity and poor in quality. Until the rain came at the end of April the old pastures and seed layers were perfectly bare, the ewes chiefly depending on trough food. The lambs are stunted in growth, and the wool is dry, denoting an unprogressive state.

The loss on a stock farm by the failure or destruction of the root crop cannot be measured by the mere value of the crop, though this is considerable. The stock of the farm has to be reduced, and placed on the market at unsuitable seasons, and in an unfit state, whilst the animals that are left on the farm are only carried through at great cost. The loss of a root crop deteriorates the manurial condition of the land, the effect of which is felt throughout the whole rotation. On an average, we estimate the loss on a stock-breeding and rearing farm—the roots were up and stored during the autumn of 1890—at from 5*l.* to 6*l.* per acre on the area of the root crop.

The depreciation in the value of store sheep during the spring of 1891, due to the loss of the root crop, has been most serious. Throughout the great turnip-growing districts of the Southern and Eastern Counties thousands of half-ripe sheep have been slaughtered, entailing a heavy loss on the farmer, whilst greatly lessening the future output of mutton. As regards the tegs that have been carried on through the winter and spring, when the cost of artificial foods has been deducted the balance will be less than their value last November, whilst breeding ewes are worth less by 15*s.* to 20*s.* per head than they were at the above date. Throughout the turnip-growing districts of England the numbers of sheep have considerably diminished.

The ordinary forage crops were for the most part cut down by the severity of the winter, and the bleak weather of the spring has had the effect of retarding vegetation. Rye, winter oats, and tares, were probably never in so backward a state as they were at the beginning of May. We have, however, learnt a useful lesson, which I trust will not be readily forgotten—that is, that of all forage crops cultivated for spring food none is so hardy as the kale tribe, which in normal seasons produces a large amount of valuable food; its recuperative powers are of the utmost value to

the stock owner. The seed layers have been heavily stocked, and so made no progress, whilst the scarcity of keep necessitated the stocking of the mowing grounds with ewes and lambs. It is not in accordance with precedent to be able to gather an average crop of hay from land that has been eaten bare till May Day, and we have seldom known hay of good quality to be secured after midsummer.

In sheltered situations brood mares, though wintered out of doors, have done well. Where liberally supplied with nutritious food they have maintained their condition and have come through in a healthy state. The foals are dropping strong, and the mares have a good supply of milk. The young stock of different ages are housed at night in boxes with open yards, and they are allowed a run in the fields during the day. They are fed morning and evening in the boxes with oats and hay chaff, and have a supply of water always at command.

We have already hinted that certain diseases which affect the health of farm stock are more prevalent in dry than in wet seasons, whereas the diseases most prevalent in a wet season are less common in a dry one. During the winter of 1890-91 the mortality amongst every description of breeding stock was heavy, though this to a great extent was due to preventable causes. There is a disease well known to the veterinary practitioner as septicæmia, or blood poisoning, from the admission into the blood of some of the organisms which abound in putrid solutions. The parturient septicæmia is the most common and fatal, and it was from this that stock owners suffered during the winter. It generally appears within a week of parturition, and is due to local contagion conveyed by the hand of the operator in difficult cases of parturition, or is acquired when the animal lies down in a shed or box in which the germs of the disease exist. Putrefactive decomposition, involving the uterus, proceeds rapidly. When taken in time, it is readily amenable to skilful treatment. Unfortunately, the disease is generally too far advanced by the time the veterinary surgeon is called in. Candour compels me to admit that the means of prevention rest chiefly with the farmer. If, in the lambing yard, the calving boxes, which are used alternately for cows and mares, are not cleaned out for weeks, decomposing animal matter, already charged with the germs of the disease, forms a suitable host for the increase and nourishment of the special organisms. The disease is highly contagious, and whether it be lambing ewes, calving cows, or valuable breeding mares, they seldom escape. If the sheds and boxes were carefully cleaned

out and regularly disinfected, the losses from this cause are capable of being reduced to a minimum.

Tuberculosis, more generally known to dairy farmers as grapes, is a fatal and dangerous disease. As affecting cattle, it is attributed to close breeding, but although common in the dairy districts I am strongly of opinion that its origin and continuance are due to an entirely different cause. There is no inbreeding, strictly speaking, in the dairy counties. The bulls are allowed to range the pastures with the cows, and for obvious reasons are seldom used more than one year, whilst they are obtained from widely-different sources. Although, in many cases, the disease may have become hereditary, tuberculosis follows the trail of the grain waggon. Wherever brewers' grains are largely used, there cases of tuberculosis will be found most numerous. At no stage of the disease is either the flesh or the milk fit for human food. This is a disease that can only be stamped out by compensating the owner. Experienced stockmen detect the disease at the earliest stages of development. The occasional weak, hoarse grunt which is as yet the only symptom is seldom mistaken, and the animal is at once sent to the auction and passes to a new owner. Except under the conditions we have mentioned the disease is not extensively prevalent, and could be stamped out at a trifling cost. Once admit the system of compensation, and every case would be reported on its first detection. To insure this it would be desirable to frame a code of stringent regulations imposing a heavy penalty on the owner who failed or neglected to immediately report a case, or supposed case, of the disease.

GILBERT MURRAY.

---

## THE CANKER OF THE LARCH.

IN the spring of last year the attention of the Consulting Botanist of the Royal Agricultural Society was called by Lord Moreton to the extraordinary prevalence of the canker of larch-trees at Sarsden, Oxon, where a large plantation on the property of the Earl of Ducie was affected by the disease; and by Mr. Faunce de Laune to its occurrence at Sharsted in Kent, where in two different copses nearly half the trees were cankered.

The disease seriously affects the plantations in Kent where this tree is grown for hop-poles; its results however are much

more serious where the trees are grown for timber, as the canker greatly distorts the trunk, if it does not entirely kill the tree.

In the course of last summer's visit of inspection to the famous pastures of England the Consulting Botanist found cases of canker in larch plantations all over England and Wales. Indeed, the disease is unfortunately too prevalent throughout Britain, and seriously endangers the profitable growth of one of our most valuable timber trees.

It is proposed in this paper to give an account of the cause of the canker and to record the results of a somewhat lengthy investigation of the subject, based on numerous specimens kindly placed at my disposal by the Earl of Ducie and Mr. Faunce de Laune, as well as to record observations made on living trees in various parts of Britain.

The existence of canker in the larch has been known in England for a considerable time, but it is difficult to determine the exact period when the canker was first observed, as half a century ago arboriculturists attributed the internal rot of larches to the same cause as canker. In 1860 Mr. Charles MacIntosh, the well-known landscape gardener, published a special work on the larch disease in Great Britain. This contains a careful review of all the literature of the subject up to that time, as well as a record of the opinions of scientific and practical men on the origin and nature of the disease. The author believed the injuries to be due to errors or faults of cultivation. Bad draining, planting on unsuitable soils, and using inferior seedlings were considered to be the chief agents in causing the disease. Even at that time it was feared that the canker would be fatal to larch-growing in Great Britain.

In 1882 Mr. C. Y. Michie, forester to the Earl of Seafield at Cullen House, published his practical work on "The Larch." He devotes a chapter to its diseases and in a few sentences disposes of the canker. It is evidently the result, he holds, of such causes as confinement, superabundance of moisture, cold wet seasons, spring frosts, or, indeed, anything that injures the outer coating of the bark. This disease, he says, is most inveterate on wet, cold soils, such as the border-lands of Scotland and the north of England.

The English Arboricultural Society offered a prize for an essay on the canker in the larch, which was adjudicated to Mr. William Clark in April 1886. Mr. Clark considers that the disease is generally found on undrained, retentive soils of bog or clay, and that the trees attacked are often found to be unsound or widely rotten at the core. He regards the variable climate

of Britain as the cause of the disease. The microscopic fungus found on the diseased parts was in his opinion not the cause of the disease, but a result of it.

The observations and views of foresters and others who are practically acquainted with the cultivation of the larch unfortunately lose much of their value because the writers have insufficient knowledge of the nature of parasitic fungi and the effects they produce on their host plants.

The real cause of the canker was not detected till 1859, when the late Sir W. C. Trevelyan called the attention of Dr. Lindley, as editor of the *Gardeners' Chronicle*, to his discovery of a small fungus associated with the disease, and forwarded specimens to him. Dr. Lindley submitted the letter and specimens to the Rev. M. J. Berkeley, the distinguished fungologist, who perceiving the importance of the observation, after correspondence with Sir W. C. Trevelyan, dealt with it in the *Gardeners' Chronicle* for December 17, 1859. Sir W. C. Trevelyan's letters (which, in view of the lack of knowledge on the subject at the time they were written, give a singularly accurate account of the disease), have, with the rest of Berkeley's scientific correspondence, recently been acquired by the Botanical Department of the British Museum.

Mr. Berkeley, influenced by the notion generally prevailing at that time, that there existed a connection between the rot in the centre of the stem and the canker in the bark, endeavoured to trace the roots (mycelium) of the fungus, passing through the wood from the centre outwards, but without success.

This decay, sometimes called "foxing," produces first a slight discoloration of the wood in the centre of the stem, which progresses until the wood becomes soft and spongy, and ultimately completely destroyed, producing a hollow base to the stem. The process is one of simple decay in the wood, which begins at the base of the tree and gradually extends upwards. It is generally attributed to a superabundance of water in the soil, but is probably due to the decay of the original tap-root, which penetrates only a little way into the soil before its growth is arrested, while the secondary roots spread out laterally to obtain the food necessary for the tree. This original tap-root, being no longer an active organ in the life of the plant, is more liable to perish, and would influence in its decay the centre of the stem with which it was vitally connected. Proper draining would be of great help in preventing this wet-rot attacking the root and stem.

In 1855 the association of the canker with the fungus was observed by a forester in Hesse, whose report in November of

that year contains a very good and clear account of the disease, and the effects it produced on the larch-tree. He attributed it to the agency of a parasite, which he described as being in its action like those which injure the potato and the vine. Several German writers have since more or less fully described the canker. The most important description, which is indeed a thoroughly exhaustive account of the fungus and its effects, was published by Dr. M. Willkomm, Professor at the Royal Academy of Forestry at Dresden, in a work on the microscopic enemies of timber. He considered the parasite to be an already known fungus described by Fries under the name of *Corticium amorphum*.

Dr. Robert Hartig, Professor at Munich, published a volume in 1882 on the diseases of trees, and devoted a considerable portion of it to the canker of larch. He showed that the fungus which had been minutely described and figured by Willkomm was a hitherto unnamed plant, to which he gave the new designation, *Peziza Willkommii*. In his recent revision of the Fungi, Saccardo has separated this parasitic plant and its allies from *Peziza*, and constituted them an independent genus, *Dasyscypha*. But he considers the fungus of the larch to be only a variety of that found on the Scotch fir, and so names it *Dasyscypha calycina*, var. *Trevelyani*. The structural characteristics are no doubt sufficient to separate this fungus as a distinct species, apart from the consideration that it attacks only the living larch, while the *Dasyscypha calycina* is found on the dead branches of the Scotch fir. Accepting Saccardo's genus, the plant must now be called *Dasyscypha Willkommii*.

Professor Marshall Ward devotes a chapter in his work on timber and some of its diseases, to the larch canker. From his own observations, and from the works of Dr. Hartig, he gives the only complete and detailed account of this disease that we have in English. The investigations recorded here lead to conclusions somewhat differing from those of Professor Ward, as will be apparent in the course of the paper. Professor Ward holds that the fungus cannot penetrate the sound bark, but infects it only through some wound or injury; he attributes these wounds chiefly to the effect of late frost.

The larch is affected by this disease in all the conditions under which it is grown in Britain, irrespective of climate, position, or soil. I have seen it attacking trees on heights as well as on low-lying land, and on the thin calcareous soil of Kent as well as on the clayey loams of the West Riding of Yorkshire. No doubt crowded plantations favour the spreading of the fungus; while, on the other hand, open woods and

especially single trees in mixed plantations are less subject to attack.

Attention is generally in the first instance directed to the disease by the flattened and deformed portions of the stem, the free exudations of resin, and the discoloration of the bark as if covered with soot. This blackening on the bark is due to the presence of a small fungus (*Antennaria pithyophila*, Nees), which is found on the bark of several other conifers besides the larch. It has the appearance to the naked eye of a covering of soot, and its true nature therefore escapes the notice of any but a careful observer.

At certain times the surface of the depressed portion produces many minute whitish cup-shaped fungi, the interior of the cup presenting a reddish-orange colour. The fungus generally takes possession of a tree in more than one place; indeed, when a plantation is seriously affected, the fungus can be seen on all parts of the trees, even on the youngest branches.

The cup-shaped fungus on the bark is the only part of the parasite that can be distinguished by the naked eye. This is the fruiting part, pushed out from the roots (mycelium), which are in full possession of the subjacent bark, in order to ripen and shed its seeds in the air. This fungus is the true cause of the canker, as Sir W. C. Trevelyan suggested. It is a parasite sending its innumerable minute rootlets into the living bark, and taking possession of the nutritive juices which the plant prepares for its own use. The fungus lives in the bark; everywhere throughout the cankered portions the bark is completely permeated by its mycelium, consisting of extremely minute branching threads, which, by abstracting all available nourishment from the bark, kills it. Further, it feeds on the active layer below the bark from which the new wood and bark are to be formed, and destroys it so that it is unable to perform its functions. Even after this cambium layer has begun its work of actively forming new wood, the mycelium spreading in the bark above gradually arrests its formation.

As the fungus grows year after year, the mycelium extends itself in search of food into a fresh portion of the bark, and so the further formation of wood is prevented, and an ever-increasing area of depression of the trunk is produced.

In Fig. 1 the ordinary form of the stem is seen at the two extremities, and the flattening caused by the canker in the centre. The origin of the injury was at a point slightly to the left of the branch, which has at length been killed by the fungus. The mycelium has spread outwards, growing more rapidly up and down the stem, causing an elongated canker. The tree



FIG. 1.—Stem of larch nine years old, from Sbarsted, attacked by canker, with numerous specimens of the fruit of the fungus (*Ditsyscypha Willkommii*) scattered over it. Natural size.



endeavours by an increased formation of wood under the still living bark to provide adequate channels for the transmission of the sap, which is prevented wherever the mycelium is present, and to strengthen mechanically the weakened portion.

I have never found the fungus beginning an attack on an old stem. When the external bark is no longer vitally active it is unable to give nourishment to the young fungus in the early stages of growth, when it pushes out its mycelium from the germinating spore. The normal dead bark, covering a tree of several years' growth, accordingly becomes a protection to that stem. The numerous specimens examined all show that they have been attacked before they were three or at the most four years old.

It must not, however, be forgotten that any part of the tree less than three or four years old is liable to be attacked, consequently a plantation, say of twelve years old, may have escaped the canker, but if spores reach it under suitable conditions, the upper and younger parts of the stem and branches will probably be attacked.

In Fig. 2 we have an instance of a tree attacked twice by the canker, first at the beginning of its fourth year's life, and later on in the same year another attack was made at the opposite side, so that in the fifth year a very small proportion of healthy bark was left, and very little wood was laid on; a greater activity of wood forming, though over a small area, took place in the sixth year, which was again reduced by the vigorous life of the parasite in the seventh year, and it is difficult to believe that, had the tree not been cut down, it could have survived another year.

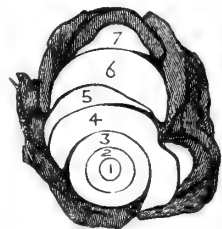

FIG. 2. Section of stem of larch, from Sharsted, attacked by canker at the end of its third year, and nearly destroyed in its seventh year. Natural size.

Fig. 3 is a section of a tree cut down in the spring of the tenth year of its life, which was attacked at the close of its third year, and the fungus surrounded half the stem, so that in the fourth year the wood was formed only round one half of the tree. During the five other years before the tree was cut down the canker continued to hold possession of even more than half the circumference, so that in the end the original centre, consisting of the first three years' growth, was outside the tree. The resin due to the attack of the fungus is shown in a large mass below to the left of the figure.

Fig. 4 is the section of a stem cut down at the beginning of the thirteenth year of its existence, which has been

attacked at the end of its second year, as shown in the lower portion of the figure. The stem has been attacked in five other places a little above or below the place where the section was made, but sufficiently near to exhibit some of the injury done to the tree at each place. The canker shown at its origin outside the second year's growth has prevented the wood forming from A to A. At A on the left side of the stem the new wood has extended over the injured portions of the previous two years' growth. The continuation of the twelfth annual ring is broken by the second canker from B to B, and extends in the section to the eighth year's growth, the origin of the canker existing lower down the stem. The next interruption to the

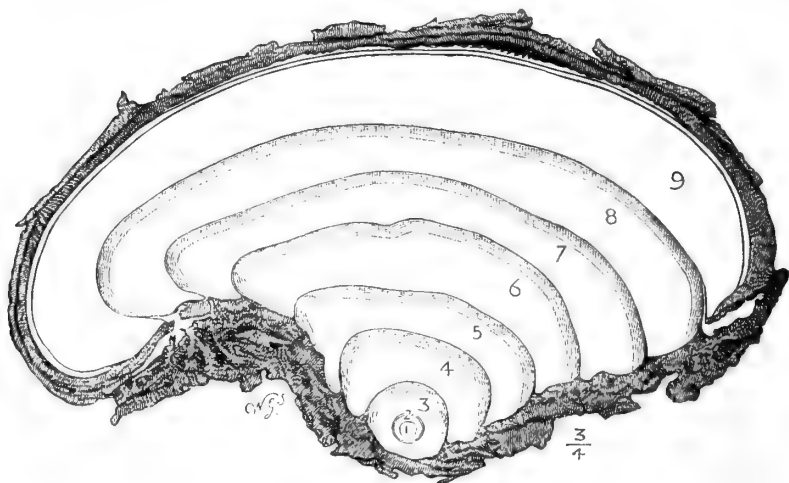

FIG. 3. Section of stem of larch, from Sarsden, Oxon, attacked by canker at the end of its third year. Three-fourths of the natural size.

formation of wood is shown between C and C, and the gap here is filled in with a mass of resin, r. The fungus has destroyed the bark between D and D, and the effect of the disease is also shown on either side of E. The white patches in the bark represent matted masses of mycelium.

The fact that the trees are attacked in the early stages of their life, as shown in the sections, is confirmed by a recent examination of a young plantation at Sarsden planted in 1887. A number of diseased larches were found which had been attacked in 1888 in the portion of the tree that was two years old.

The evil influence of the fungus on the larch is, as we have seen, entirely due to the life of the mycelium of the fungus in

the tissues of the bark. It penetrates the cells and fills their interior, extracting for its own nourishment the substance of the

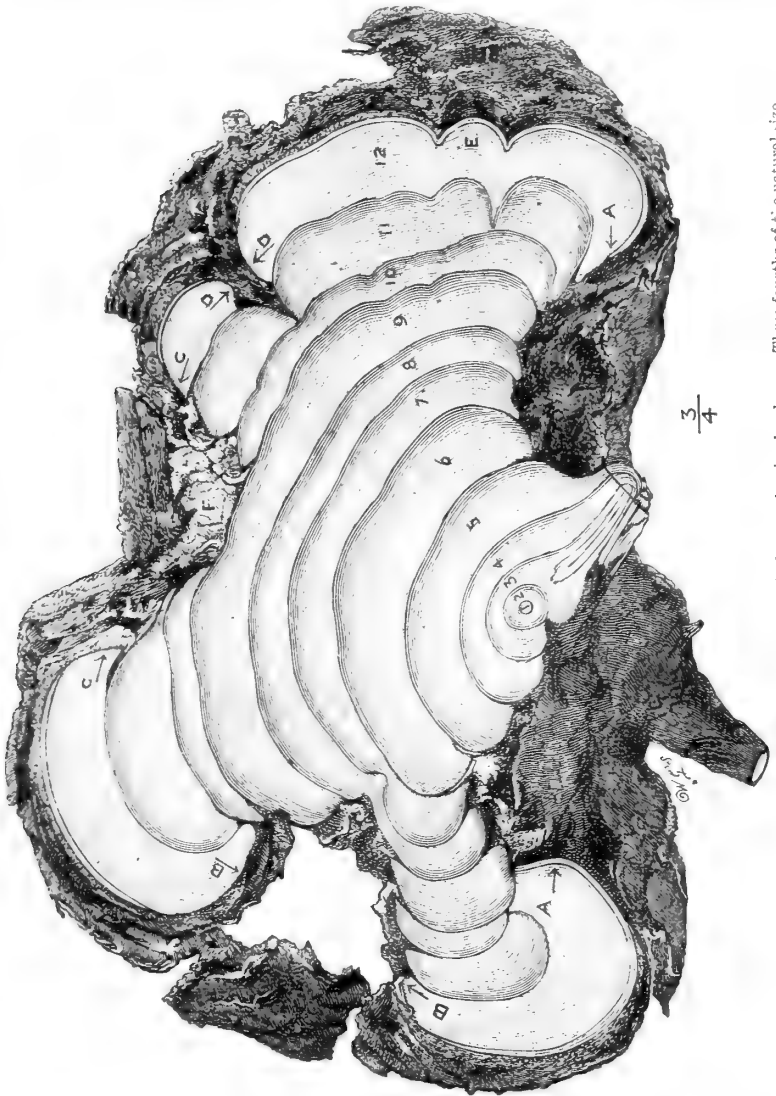

FIG. 4.—Section of a larch, from Sarsden, Oxon, attacked by canker in six places. Three-fourths of the natural size.

bark, and pushes its way to the inner surface of the bark, where it consumes the active cambium layer.

The fungus in the course of time pushes its way to the

exterior, compact masses are found near the surface of the bark, and these give rise to the minute, roundish, white bodies which are seen scattered over the diseased part in Fig. 1.

These white bodies gradually increase in size and open out into flattened cups with a raised white border and a flat concave centre of a bright orange colour. Fig. 6 represents a piece of bark from a tree in a small plantation near Newton Morrell, North Yorkshire, with large and well-developed cups of the fungus.

In Fig. 7 we have a highly magnified section of a young and scarcely

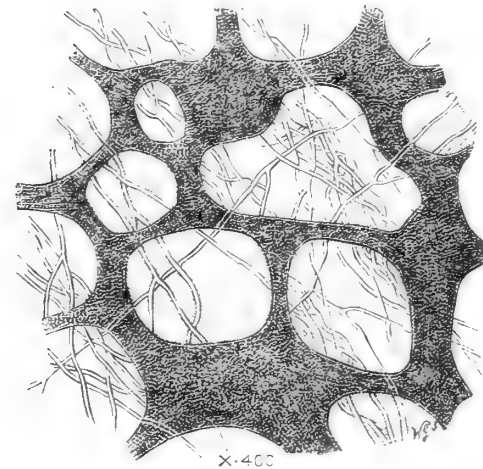

FIG. 5.—Bark cells, showing the threads of the mycelium of *Dasyscypha Willkommii*, magnified 400 times.

opened fruit, as well as a mature one. The mass of mycelium terminating in the fruit is shown in this section. The bright

orange-coloured centre of the fruit contains the seeds or spores of the fungus. It consists of an immense number of minute elongated sacs intermingled with empty threads. Each sac (Fig. 8) contains eight spores of an oval form arranged obliquely.

When the spores are ripe, the top of the sac splits off like a little cup and allows them to es-

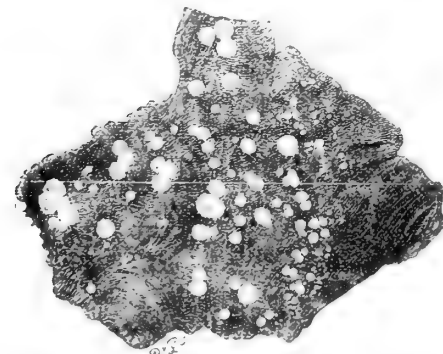

FIG. 6. Piece of bark with fruits of the canker fungus. Natural size.

cape. One cannot realise the enormous number of spores which are produced by a single cup. These innumerable spores are carried about in the air, and wherever they settle on the bark of a young larch and find sufficient moisture to cause them to germinate and enable them to push their minute roots into the

bark, canker is originated. When the fruits are ripe and the spores are discharged, the air is filled with them. They are so microscopic that the eye cannot detect them, yet each spore is able under suitable conditions to germinate. It has been stated that it is necessary for the spores to fall on an abrasion or a wound on the stem or branch of a tree in order to effect an entrance, but

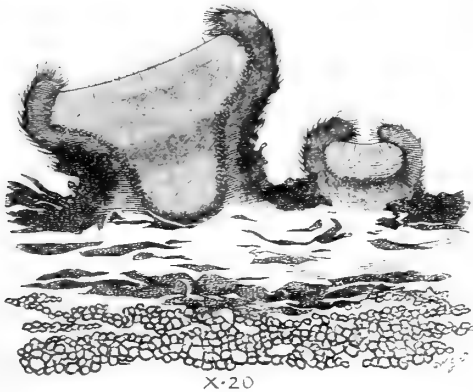

FIG. 7.—Section through two fruits of the fungus, magnified 20 times.



FIG. 8.—Spore-bearing sacs of the fungus, magnified 400 times.

the examination of a very large series of recently attacked larches does not confirm this view. It appears that the spore germinates on the surface of the bark, but it is possible that it may fall or be washed into a crack. In the first stage of its life it is dependent on the external moisture. Should the atmosphere be dry, and should there be no water on the bark, the spore could not germinate, and myriads of spores continually perish in this manner. But if it obtains the very little supply of water needed, the spore sends out a small thread which pushes its way into the bark, and having got hold of the bark it is no longer affected by external dryness or moisture. It obtains all it needs from the living juices of the tree. The numerous cases examined, especially in very young trees just attacked, furnish no evidence that the fungus can infect the larch only through a wound or injury. The bark in such young trees is found to be unbroken. This fungus has the same power as the potato fungus of penetrating the protective covering of the plant, but in this case it

can penetrate only the young bark. Bark four or five years old appears to be impervious to the attack of the fungus.

It should be carefully observed that this disease is limited to the cankered portions of the stem, being purely a local injury, and that the trunk below is healthy, there being no connection between the disease and the roots of the tree. It cannot be communicated to other parts of the tree by the juices or through the wood. Each fresh canker is caused by a new and independent attack and is entirely due to the germination of the spores of the fungus on the bark, and is not in any way the result of the physical causes which have been credited with it, such as confinement, excess of moisture, cold or wet seasons, spring frosts, &c., except so far as these have favoured the growth of the spore by providing the moisture necessary for its germination.

From this account of the canker it must appear that no method can be suggested which will effectually prevent the attack of larches by this disease. Were it clear that the spores could gain entrance into the tree only through a wound or injury, arboriculturists, by keeping the bark of their larches uninjured, would ward off the disease. It is, however, plain that the spore secures a hold without the presence of a wound, and consequently any treatment with a view to preserving the young bark from injury is of no avail.

The time to take steps to prevent or cure the canker is when the trees are very young. When planting, each one should be carefully examined, to discover if it has already been attacked, and every specimen found to be diseased should be rejected and destroyed by fire. Careful inspection should frequently be made of the young plantations, so as to detect the first appearance of the disease. This can be determined externally even before the small white cup makes its appearance, by the darker and depressed appearance of the bark where the fungus is growing, and should there be any doubt as to the presence of the fungus, the slightest cut with the knife will show the very dark colour of the injured bark. If this dark bark is carefully cut away the disease would be arrested. No portion of the diseased bark must be left, else the mycelium of the fungus will continue to live and spread from that portion through the healthy bark. It must be remembered that the fungus does not penetrate the wood, so that when the bark is removed the seat of the disease is got rid of.

The same operation may be performed on older trees, but when the canker is large there is little hope of the wood growing over the injury, whereas in the young tree one has good reason to expect that the injury may speedily be repaired by new wood

gradually spreading over the exposed surface. To encourage this it would be well to dress the exposed portion with some substance fitted to protect it.

The fragments of diseased bark which are cut off should not be left on the ground, but should be carefully put in a bag and afterwards destroyed by burning.

The conditions which are essential to the successful growth of other timber trees are all equally important in the case of the larch. The crowding of healthy trees, while not advantageous to their growth, is very dangerous when a tree is attacked, as the infection of its neighbours by the spores is greatly facilitated.

Though every effort be made to combat the disease in districts where plantations are extensively attacked, and the trees have been greatly reduced in value, it may deserve consideration whether it would not be better to replace the larch by other trees suitable to our climate, and fitted for the purposes for which the larch has been so long employed.

J. B. CARRUTHERS.

---

## EXPERIENCES OF A SCOTSMAN ON THE ESSEX CLAYS.

THE occupation of land in Essex by Scotsmen has become so frequent that the settlers are often termed the "Scotch Colony," although they are scattered up and down the county, and occupy different kinds of soil. Ongar, Brentwood, and Chelmsford, however, represent the sort of centres where the greatest number are to be found. A very large proportion, in fact the majority, are from the district in Ayrshire of which Kilmarnock is the centre; and as this is a famous dairying locality, it follows that the immigrants brought their dairying propensities with them, and largely converted their farms into milk manufactories. It is doubtful if, of recent years, dairying pays better than other forms of farming; but when people have been accustomed to it, like it, and have the necessary technical skill, they do well to adopt it, even in a new and untried country.

The question has been asked, Why so many Scottish farmers come to this and other parts of England? The question may be answered in a very few words—excessive rents at home. There is not the least doubt that "the depression" has been very badly felt in some parts of Scotland, especially the eastern agricultural

half; but the dairy districts were the last to feel the storm, and have weathered it best. In the case of these latter, much of the work is done by the farmer and his family, especially in the smaller holdings, and there has been a tremendous competition for every vacant farm. This, of course, raised the rent, and even now there are so many would-be tenants that the one who is, unfortunately, the successful competitor for a vacant holding, has offered a rent which means a ceaseless struggle to enable him to make ends meet.

This combination of high rents and a greater number of farmers than can possibly obtain farms can only mean that the latter must "hive off" to another locality. About eight or ten years ago reports and advertisements of vacant farms in the south of England appeared in the papers—notably in the *North British Agriculturist*,—land actually going begging for tenants; so we turned our eyes southward. First one or two came, and finding the taste good, sent back a satisfactory report to their friends behind. When these latter came, they in their turn sent for other friends, until now the country is overrun with us.

The first consideration is, of course, the rent; and the Essex squires, never having been accustomed to what a Scotsman would call a big rent, meeting with tenants who had, came to terms with comparative ease. The chief difficulty has been the buildings. In the North there is always a superabundance of stone of some sort—sandstone, basalt, granite, &c.—so that the farm offices, however inadequate they may be, are solid and substantial. Here in Essex there is no stone of any value.

This want of cheap building material has necessitated the extensive use of the native timber (oak and English elm), and thus we see whole homesteads made of oak framing and elm boarding. When these are new, they are as good as any one could desire—cheap, comfortable, and easily adapted to any kind of stock; but when old and rotten, and settled down off the plumb, they need to be accompanied by very cheap land indeed to catch the North-countryman. Thus the landlord has often to lay out a considerable sum on the buildings in merely putting them into tenantable order. Besides this, there are often many additions and alterations required for the new style of farming being introduced, such as fitting up a byre, bringing water in pipes to the house and yard, &c.

Coming from a country where long leases were the rule, it was a novel experience to have farms as yearly tenants; but I, for one, prefer to have it so. On this farm where I write there was at first a short lease—now expired—and we now sit on at a twelve-months' notice; the Agricultural Holdings Act, plus



nitrate of soda, makes me feel easy in mind regarding this. The majority of in-comers, however, have had their choice in this matter, but I have not heard of any who have taken a long lease.

It is a gratifying feature of this Northern irruption that no English farmer has lost a home to make way for the in-comers, so far as I am aware. The farms were either quite unoccupied, worked by the landlord, or the old tenant was leaving in any case, and if the North-countryman had not arrived there would have been no tenant at all. As to the reasons why the latter succeeds where the former failed (or apparently does so—for ten years is perhaps too short a time in which to judge of the success of a movement), I have my own opinion, but it is outside the scope of this paper to enter on this question.

The title of this article is to some extent misleading regarding the nature of the soil in Essex. A very large extent is, of course, a stiff clay soil, formed from the weathering of the London clay proper; but there is quite as much of the surface of the county occupied by what is known to geologists as Bagshot sands and gravels, boulder clay, glacial drift, &c. In fact, a look at the one-inch scale Geological Survey map shows that there is comparatively little of the brown colouring indicating the clay formation. It occurs chiefly in the hollows and valleys, while the tops of the elevations and knolls are occupied more or less with soil full of flint gravel, and of quite a different nature from the clay. For one thing, it is not so fertile naturally as the clay, and in some places is actually barren, forming the various "heaths" and forest-lands (such as Epping Forest) of the county. Where the lighter soils of the boulder clay and glacial drift prevail, however, we have a very fertile district, such as the famous Roothings of Essex.

Another practical difference between the heavy and the lighter soils is shown in the manuring. Coming from a district where whole or dissolved bones were almost the only artificial manure used (excepting, of course, nitrate of soda), we preferred to stick to them, but found they had not the slightest effect. I have always been in the habit, during the last few years, of leaving a ridge unmanured right down a field when applying a dressing of artificials, and of giving the next ridge a double dose. By this means one can tell pretty accurately the effect of an application of any dressing, without going to all the trouble of measuring and calculating, as is the case with elaborate experiments. I thus found that on our clay phosphatic manures have no direct appreciable effect. On the other hand, all nitrogenous manures, such as guano—with, of course, nitrate of

soda and sulphate of ammonia—tell instantly and advantageously. Notwithstanding the fact that guano is far above its value if reckoned by units, in the same way as we value other artificials, yet it is the most profitable in the end. I find that bones are adhered to, however, by those Scotsmen who occupy the lighter and more gravelly soils. The latter are, of course, more easily cultivated, and the times of working less dependent on the weather; but that is not saying much, because both are difficult enough. A great point in favour of Essex is the comparatively small average rainfall. The same soil in the North would be looked on as almost hopeless; but here we think it the best of all, and, in fact, when we are advising a “brither Scot” who is on the outlook for land in the South, we always warn him to beware of light land, and take the heavy in preference. When I see South-country Englishmen bewailing the misfortunes of clay-land farmers, I cannot help wondering if it is their limited experience makes them do so. If they had to farm clay land in Scotland with forty inches of rainfall per annum, they would know more, and have something to complain about.

I was born on a farm in Ayrshire where the soil is as stiff as any I have seen here, lying, as it does, on the red and yellow boulder clay of the coal districts. Here, however, the rainfall is only half, and light land would be burnt up where clay land is benefited; while the “inherent fertility” of the clay is superior. Of course, I am referring to land which can be ploughed with two horses abreast; three-horse land I believe to be rather scarce. I am aware that there is some such land where it is absolutely necessary to put three horses in a line to plough it; but in one instance where I saw this done, I found when the man went away to dinner that I could pull the plough myself, as the soil was so light. I infer from this that three horses are often put in where there is no need for them. I am able to give the exact measure of the stiffness of our soil, however, from dynamometer trials of different ploughs. In lea land, ploughing with Ransome’s “Newcastle” wheel plough, and Howard’s “Essex” plough, the draught is one cwt. for every inch in depth of the furrow—a five or six inch furrow requiring five or six cwt. to pull the plough. This we find a pair of horses can do for a day of seven to eight hours, although it is quite three times as much as ordinary land, and four times that of some light land. I have tried three or four kinds of the American chilled ploughs, which do so well on light land, but the draught was no easier than Ransome’s with mould-board No. 95, while the short stilts rendered it impossible to guide them steadily. If any soil is stiffer than this, then I hold a very

decided opinion that it ought not to be cultivated at all, at least with horses.

While on the subject of ploughs, I may mention that no Scotsman can possibly approve of the native Essex wooden implement. Apart altogether from its clumsiness, it has two faults: the mould-board has not got twist enough, so that it does not turn the furrow-slice properly; while the share commonly used has too wide a feather, so that the furrow-slice is cut clean out, and will not hold against the mould-board sufficiently to be turned. These defects do not appear in stubble or fallow ploughing, but become at once apparent in lea land; in fact, I thought the ploughing was well enough for the first three or four years after I came to Essex, and it was only when we began to break up land which had been laid away in pasture for that length of time that the gaping, badly-turned furrows could be seen, and led me to try other and more improved ploughs. North-countrymen who have brought their old ploughs with them find they do not suit the soil: the mould-boards are too short and wide set, so that two horses cannot pull them; while if the wearing surfaces are of the country-smithy, cast-iron kind, the friction would be too much for even three horses.

I must acknowledge, however, that there are many things about the native system of ploughing superior to that of the North, and these we have of course adopted. In opening up lea land from the flat, it is the custom here to "plough out" two furrows in what will be the centre of the ridge or "stetch." One of the said furrows is "chucked away," and then the furrows are ploughed inwards of the full depth from the first. In the Scottish method, the furrows are ploughed inwards from the beginning—very narrow and shallow at first, and the result is that, though the crown may be perfectly level across (one of the tests of good ploughing at matches), yet the grass springs all too readily among the crop where these shallow furrows are. I find our ploughmen lay off the ridges (or "stetches") much more easily than ever I was accustomed to in the North. A man will "draw off" a field with his plough and a pair of horses with no assistance, and do it perfectly well. He carries a 7-foot measuring stick in the body of his plough, with which to lay off the widths; a few twigs cut from the nearest fence are used as marks, or saplings split down the middle so as to show a white face which can be seen at a distance, and that is all. The reins hang loose on the stilts of the plough, the horses are guided by the voice alone, and the result is furrows of marvellous straightness. It is not uncommon in the North to see two men with sticks painted like barbers' poles, and a tape, or even Gunter's

chain, measuring off the land for the ploughman who comes behind.

The native arable farming we immigrants found on coming might be described as an irregular four-course shift: wheat, bare fallow, roots, English broad red clover, beans and peas, were grown in various orders, to suit particular circumstances, the wheat and fallow occurring as often as possible. The bare fallow was the only thing to which we had particular objection, as on the face of it we could not see how cheap wheat was to pay the expenses of a dear fallow, and its own expenses as well. Of course, fallowing is not entirely unknown in the North on clay soils, but it is the next thing to being unknown. The Agricultural Returns some time ago showed that, while in Scotland only 1 acre is fallowed out of every 254 (arable), in England there is 1 in 27, or, taking Essex alone, 1 in 15. Climate has, of course, a good deal to do with this, fallowing being very difficult in a wet district. But a very slight acquaintance with the philosophy of farming showed us that the benefits to be derived were purchased too dearly. It is carried out for the purpose of killing weeds, and for mixing and pulverising the soil, so that more plant-food may be set free. Regarding the killing of the weeds, I shall have something to say later on; but I may here say that it certainly does not kill thistles; it simply "breeds thistles," and they increase in direct proportion to the amount of land fallowed. Any one can see this proved by noticing how soon a heap of bare earth in a grass field gets smothered over with them, as the down blowing in autumn is fixed by the loose soil, and every seed grows, while not one in a thousand takes root on the grass. Regarding the second point, every one knows that removing a crop, without replacing by manure the ingredients removed from the soil, must eventually impoverish that soil. In fact, the soils of many farms known to me have been so reduced that only a very poor crop can be reaped, and the new men have had to launch out money very largely in order to bring the soil up to a fair standard.

It is a proof of the great natural fertility of the Essex clays that they have stood this scourging system so long without absolutely giving out. It is wonderful the effect that dung from cake- and meal-fed cows has on such a soil. On our farm at Ongar, we were informed on taking it that it did not require manure, and had seldom had any supplied. We find that a respectable crop is not to be had without a dressing of some sort, and it is only getting into form now on going through the second rotation, and there are dozens of farms of the same

kind. No Scotsman can ever be brought to see the necessity for three, four, or five ploughings; if the land has to be fallowed, it will be done with a three-horse grubber, getting over from three to five acres per day. In fact, we cannot help thinking that our English neighbours literally waste the labour of men and horses, from the laborious way of doing their work, and the clumsy machines with which they do it. I remember seeing on this farm six horses in a set of harrows on the fallow land, with two men sitting on the top driving; also, four horses in a Crosskill roller, while three or four were always put in a drill; now there is not a tool on it needs more than two horses to pull, except a three-horse drag-harrow; an American two-horse drill sows seed and manure at one operation. The Suffolk drill we found so cumbrous that we threw ours aside, and I sowed the seed broadcast by hand for a year or two. Wheat grown on land treated to so much expensive labour does not of course pay: it would not pay even if it were tithe and rent free, and it is part of the object of this paper to show how the Scottish colony in Essex work on a much cheaper scale, and, so far as I have yet seen, with gratifying results.

The first thing was to reduce the number of men and horses; for however sorry one may be about depriving working-men of their opportunity of earning a wage, self-preservation is the first law of Nature, and a farmer obviously could not find work for men to his own detriment. This has been done in a variety of ways: partly by using more modern implements, partly by doing without a fallow, and partly by putting away some of the arable land into temporary pasture. The first of these requires no explanation, as the Americanising of our machinery is a thing that is gradually going on, and we are getting lighter and handier tools every day. If fallowing is abolished, however, one wants to know what is going to take its place. Roots, of course, have generally done so; but the writer is opposed to root-growing—at least, in the South country; and on this holding (a square mile in extent) the root area has been gradually diminishing, until it has at last arrived at zero. If the land has been properly cultivated and treated, however, I do not hesitate to say that a fallow is quite unnecessary. But to attain this end the soil must be properly ploughed to begin with (a thing very seldom done), so that all grass, weeds, and surface-rubbish be properly covered in, and to as great a depth as possible. This gives the crop a start, so that the weeds never get up to any extent, and are thus partly choked or weakened. I have seen one ridge with a perfectly clean stubble after the lea crop of oats was removed, and the next ridge excessively foul—the difference being due

to the ploughing alone. The next thing is to have the crop well manured. If there has not been dung put in the land, then there must be artificials given; but I prefer both together—the artificials rich in nitrogen. Then there must be thick seeding. I am convinced that many crops—especially wheat—are sown too thin, and are lost for this reason. So we use quite 50 per cent. more seed per acre than many in the neighbourhood do, and are satisfied with the results. All these things combined produce comparatively thick, heavy crops, which help to smother all other growths, so that weeds never become so rampant as where a thin, poor crop, on badly ploughed land, is grown. For the same reason, we find tares one of the best crops, and always grow as many as we can possibly use, to be followed by wheat.

But, of course, all this would not be sufficient to keep the land perfectly clean, so that it is necessary to attend to some other alterations in the management—and a description of these I now take up.

As a point of great importance in the system of reducing labour, there comes the reduction of the laboured area by the putting away in temporary pasture. The making of permanent pastures is a subject that has been greatly exercising the agricultural mind for some years past; but I do not hesitate to state my personal opinion that, on ordinary soils, this is a great mistake, though, of course, there are many exceptional cases where the land ought to be in grass, and never ploughed up again. But putting into grass for a few years is quite a different matter, and has everything to recommend it. It is, in fact, adopting a six, seven, or eight years' rotation, three, four, or five of which are in "seeds." By this means the total amount of actually ploughed land is permanently reduced, as for every lea field broken up there is one laid down; at the same time, the "vegetable soul" of the soil is renovated by the formation of a young turf, while the weeds disappear more or less.

We thus attain a great many desirable ends, the first of which—saving of labour—has already been commented on. Regarding the second, it may be pointed out that the perpetual cultivation of land not only tends to reduce its store of fertility, but actually to change the mechanical nature of the soil. A clay soil like ours becomes stickier, and worse to work, a state of matters greatly modified by the growth of a mat of roots of grasses for a time. In the same way the effect of a dressing of dung ploughed in is wonderful. Practical farmers are well aware of the good crops derived from newly broken up land, and the superior benefit accruing from any manures put on such a

soil. As to its effects in enabling us to clean land, arable land has developed weeds peculiar to itself, and these will not grow among pasture for any length of time, any more than wheat will grow there. There are three grasses which foul our land here—couch-grass (*Triticum repens*), black bent (*Alopecurus agrestis*), and water-grass (*Agrostis vulgaris*). The first two of these literally die out of themselves whenever the land is put into pasture on this soil. On light soil couch would likely persist, but not so on our stiff clay. The last one mentioned is our greatest trouble, at least where the fields are wet; but it also succumbs to manuring. Instead, therefore, of the laborious and expensive cleaning of land by a bare fallow or by roots, we simply plough properly, manure heavily, grow good crops, lay the land down to grass, and there is no further trouble. I do not, of course, mean it to be inferred that there is not a single blade of couch, or the like, on the farm, but I certainly maintain that there is not enough to be troublesome, or conspicuous, or enough to sensibly interfere with the growth of any crop. To this I must except some seventeen acres on which roots were grown in former years. Although 50s. per acre was spent in hand-hoeing in addition to horse-hoeing, yet the land is now, when laid away in “seeds,” overrun with “water-grass,” and I doubt if it will clean itself without cropping and sowing down once more. Otherwise the farm is practically as clean as there is any need for it to be.

The composition of the grass mixture will interest many, and I have already been often asked for it. It has been the result of a good many years' experience now, and I made it up and modified it largely from noticing the kinds of grasses which naturally throve best, or were most conspicuous in the locality. It has been objected that I omit meadow fescue. This grass is very scarce in the locality, and therefore I never thought of adding any of it, though possibly it might do better in such a mixture on arable land. I have, however, tried tall fescue in the mixture, but without getting it to grow satisfactorily. The tall oat-grass (*Avena elatior*) grows abundantly along the fences, but I have also failed to get it to grow well. I have therefore—after altering a little from year to year—settled down to the following kinds and quantities per acre :

	lb.		lb.
Perennial rye-grass . . .	13	Perennial clover (broad) . . .	3
Italian rye-grass . . .	5	White clover . . .	2
Cocksfoot . . .	5	Alsike clover . . .	2
Timothy . . .	3	Trefoil (or Lucerne) . . .	2
Meadow foxtail . . .	2		—
Red clover (broad) . . .	3		40

This costs about 1*l.* per acre on the average of years, and we have been abundantly satisfied with the results, and have no difficulty in disposing of the big crops of "mixture" we have mown off many of the fields. We have been advised that, for a four or five years' lea, less seed would do per acre; but I am a great believer in thick seeding, and think that grass often fails from too small a quantity being sown. There does not appear to be any failure after a few years, such as I often hear about, but the sward goes on improving, so that it is with regret we break it up again when its turn comes round. Of course, the land is put into good heart to begin with, but then that is one essential part of the system. These "seeds" are either cut for hay, or grazed with milk-cows, sheep, or bullocks, just as it happens to suit.

It will thus be seen that fairly good crops are grown at a minimum of cost, and that making wheat profitable at 30*s.* per quarter is no mystery at all—in fact, it is the most profitable corn crop we have where the straw can be disposed of for a fair price. It will be inferred as a necessary corollary, that the crops ought to be improving year by year, and we find that they are. Our first wheat crops averaged 3 and 3½ quarters per acre; the crop of 1888 was 5 quarters, of 1889 was 4 quarters, and of 1890 was 4½ quarters. But the most striking improvement is in the oats. The weight per bushel five years ago was 38½ lb.; now it is 40 lb., a difference I attribute solely to the muck, which is the "mither o' the meal-kist," and which has been applied to fields which never had a dressing before, at any rate during the present generation.

While on this subject, I must not omit to mention the part played by gas-lime in ameliorating the soil. The action of lime on a clay soil is well-known, and in this district we use immense quantities of the spent lime from the London gasworks, which we get at the cost of the carriage. It is applied in various ways, and many are foolish enough to use it without manure. We have applied it raw to the coarse parts of pasture lands, but it seemed to make them still coarser, at least during the first year. Some mix it with earth for compost for top-dressings, and some apply it to the fallows. We prefer to apply it raw, at the rate of from 4 to 6 tons per acre, in autumn, to the lea land that is to be ploughed up during the winter. By this means all "grubs" are killed, the turf is partly killed, the soil is made more friable, while, of course, the natural fertility is stimulated. By itself, I have seen it act on a crop as strongly as nitrate of soda, but the soil must be fed along with it. Its effect on the mechanical texture of the soil is wonderful. I remember one case of a field that was partly dressed and partly



left undressed with it, and in broadcasting the seed afterwards, I could feel the difference in the soil in stepping from the one part to the other every time I went up and down the stetches, because the limed part was so much more loose and friable. Some maintain that it does no good to the soil, either mechanically or manurially, but we would not like to farm without it here. Of course, the land is ready for a fresh dressing every time the grass is ploughed up. I have not seen the crop killed by as much as 6 tons per acre, while, even on the permanent pasture land, 3 or 4 tons put on raw did not do any injury in this way. There are two varieties of this spent lime used here—the blue and the white. It is generally understood that the former is more poisonous than the latter, from having been used longer in purifying the gas; but for this reason it is more effectual in its action, and its poisonous sulphites are oxidised long before the crop is sown.

I do not happen to know of anyone who continues making silage here, notwithstanding the great benefits which we read have been derived from its use. In the excessively wet season of 1888 a good many tried it on the stack system, but I have not seen or heard of any that continued the experiment. The conclusion arrived at was that ensilage would do for wet weather, but that it is better to make hay if we could possibly get sunshine. A stack of silage was made on this farm, and a haystack built on the top for pressure; but the silage heated excessively, and I have been told that there was not enough pressure. At any rate, this silage decreased the milk-yield of the cows very rapidly when fed to them on two separate occasions, and it had to be given to store cattle. We have not tried any since. As no roots are grown, the succulent food of the cows in winter is entirely made up of chaffed hay, bean-meal, ground oats, and boiling water—a mixture that I have satisfied myself over and over again is better and cheaper than either roots or silage, and which is in almost universal use in the dairy districts of Scotland.

One of the greatest changes in the system of farming, brought about by the in-comers, has been the general turning to dairying. It was not, of course, entirely unknown before, but it was only a single farmer here and there who followed it, while the great majority of the in-comers—being already dairymen—have kept on at it. Many, indeed, as they were leaving farms in Scotland, simply transported the whole of their live and dead stock to the South, hiring a special train for the purpose, and starting a fully-equipped herd of cows at the very first. It would appear that the district was celebrated for its dairies long ago, before the era of corn-growing set in, more especially for

butter—as Suffolk was at one time celebrated for cheese. In Mrs. Beeton's *Book of Household Management*, it is stated that Epping butter is the kind most esteemed in London; and I remember learning out of my geography at school, more than twenty years ago, that Epping was "famous for butter." These statements, however, must have been traditions descended from the ancients, for, so far as I am aware, most of the butter sold about Epping now has been made either in Normandy or in Ireland, for the few dairy-farms in the neighbourhood are all taken up with the new milk trade. That does not alter the fact, however, that much of the land is exceedingly good butter-yielding soil, but it is not all of this kind, unfortunately, for I know of instances where the butter yielded from a given quantity of cream is at least 30 per cent. less than in some other cases. So far as I can make out, the "boulder clay and drift" soils of the district are better than the London clay in cream- and butter-yielding power—contrary to my expectation,—and this irrespective of feeding or treatment of the animals. The proximity to London, however, and the superior handiness of the new milk trade, has made us all take to this style of working. Most of us have come here to escape the drudgery of cheese- or butter-dairies, such as are the rule in the South-west of Scotland, and many would prefer to have sheep and cattle, with no cows at all; so that if we must have a dairy, it will be on the easiest system. It must be acknowledged that cows do very well in the district, and though new milk is not as profitable now as it was six or seven years ago, yet it has a great many things to recommend it. A very large quantity of the produce of the farm can be consumed at home, thus retaining a larger proportion of the fertility of the soil; the money is received in monthly instalments as you need it, in place of only at one or two periods of the year; and an immense quantity of valuable dung is manufactured at home. Of course I am referring to dairying where large quantities of cake and meal are bought in, the residue of which goes to enrich the land.

Unfortunately some of the proprietors of the district have formed the idea that cows impoverish land, and refuse to let their farms to dairymen, and this in spite of all the evidence that has been made public on the matter respecting the small amount of fertility removed in milk, and the large amount returned in the cake and meal. One large farm in this neighbourhood was refused to a Scotsman for this reason, and it is at present being farmed by a bailiff.

Reference has been made to the application of dung to the arable land, and it is from the cows that most of it is pro-

cured. But there is not enough of it, and in our case several hundreds of tons of stable manure have to be brought on by rail; the home-made material, however, always gives the best results.

The breed of cows which we nearly all prefer is, of course, the Ayrshire, though many take to the Shorthorns. The belief in the Scottish breed is not, however, due to prejudice, because we can make more money through them than through other kinds. They cost less to start with, as the most of us (coming from their native district) can get a truck-load sent south at the lowest possible figure; and we find they milk as well as the ordinary Shorthorns, and rather better than at home, while they need decidedly less food. The drawback is that, in this district, the old cows sell at very little; but as the loss is spread over five or six years, it does not amount to so much. Those who work with Shorthorns prefer to buy in immediately after calving, keeping them only one season, and then disposing of them to the butcher. We find our Ayrshires tend to grow larger and coarser than the usual type of the breed; but, on the whole, the change to a hotter and drier climate seems to agree with them. Being of a more nervous temperament than the phlegmatic Shorthorn, the torment of flies in the heat of summer affects them more, so that it has been found necessary to put them indoors during the hot afternoons, and feed with tares or other green forage. They take kindly to the old, permanent "meads," however, and the quality of the milk yielded on this class of land is superior.

A word may be said regarding the milking of the cows. This is almost universally done by women in Scotland, and it was quite a change to have men and lads at it. We find, however, that it is generally better to take on lads, and teach them, than to have older men who have previously been accustomed to larger cows, such as Shorthorns or Dutch. Dairying has thus become quite a feature of the district, and where six or eight years ago only one or two persons were engaged in it, there are now a dozen. But it is only a feature, and the rest of the farming goes on pretty much as usual. With us on this farm there is quite as much capital invested in sheep and bullocks as in milch cows, while there is always a large amount of meadow hay and "mixture" for sale.

Of all the different breeds of sheep which are common in the locality, there are none that give us more satisfaction than the Romney Marsh, but unfortunately the supply is limited; Suffolks and Hampshires are more common, but during the last year or two the price of store animals has been so high that there was no chance of buying with any room for profit in selling fat. On

several occasions we have, therefore, brought Scottish sheep south, and have had much better results. These are "Crosses" (Border-Leicester Blackfaces) and "Half-breds" (Border-Leicester Cheviots)—sometimes designated in Scotland "Greyfaces" and "Whitefaces" respectively.

The initial cost is comparatively less, and there is a larger percentage profit left on the outlay. These sheep are, as far as possible, grazed on the "seeds" above described, being, of course, allowed cake from the beginning of the year, having been purchased in during the previous fall. Many will think that a breeding-flock would better suit the circumstances, and no doubt there is much to be said in favour of this view, more especially as bought-in ewes in lamb do well. But then a regular flock means a professional shepherd, with all the troubles of the sheep-world added on to those of the dairy. During the occupancy of a previous tenant, however, sheep were the only stock.

Live-stock from the North do not always prove a success, however. We have had three- and four-year-old Highland bullocks from Islay, as a change from the Welsh or Shorthorn animals usually bought at Barnet or in the neighbourhood, and these did very well. But the butchers grumbled about their not being as well filled up with fat inside as they expected, and as weighing-machines were not in vogue then, they got their own way. From this it will be inferred that the land is not such as will "fat a bullock," and we find it needs a large quantity of cake with any breed. It will be noticed that Scotsmen have practically two strings to their bow in the matter of live-stock, because if the local supply does not suit them, they have their native district to fall back on, where prices are generally easier; and there is no doubt this choice of markets gives a better chance of profit very often. Dealers, or friends left in the North, can send up a few truck-loads of sheep or cattle on the shortest notice.

I must not close without detailing one more experience—that relating to haymaking. The difference between the English and Scottish systems of haymaking has been so often commented on in the farm journals as to need no detailed description here. It may be shortly stated by the present writer—who has made hay in both countries—that the English system is immensely superior to the other, but entirely inadmissible in Northern districts. In the South the hay is stacked out of the swathe, and allowed to "sweat" in the stack. If this were done in the North, it would go "rotten black as muck," excepting, perhaps, in a very dry season. It must first be built into little ricks in the field, where a preliminary heating is gone

through, before it is fit for the stack. I have seen hay stacked in the South with perfect safety that would only be considered in Scotland fit to cock ("quile," as it is called). This means, of course, that the labour is very much less, and, in fact, only costs about one-third or one-fourth of the sum per acre that we paid in the North, although the wages per man are nearly alike. We find it averages from 4s. 6d. to 5s. 6d. per acre for labour, or about 4s. per ton of hay made. This is, of course, simply due to the style of working which the climate permits. Heated hay is looked on with suspicion in Scotland; hay will not be looked at here at all unless it is heated, and "as brown as a berry." Since the advent of so much "mixture" hay here, however, there is a greater tendency to believe in the benefits of green-cured fodder. Personally, however, I prefer that which has had a gentle "sweat."

One might go on almost indefinitely describing the various experiences met with in changing from North-country to South-country farming. Details might be given regarding the labourers and the method of working, wages, the beer question, &c.,—all of which are different from what we are used to in the North, and which intimately concern the success or failure of the farming—and of the improvements (or what we believe to be improvements) on the native methods. But the most prominent points have been touched on, and perhaps enough has been said to show why West-country Scots have taken so kindly to Essex soil.

PRIMROSE MCCONNELL.

---

## SUGAR-BEET CULTIVATION IN AUSTRIA.

IN an article on the subject of the present position of agriculture in Austria-Hungary, which appeared in the last volume of the *Journal*,<sup>1</sup> I endeavoured to give a picture of the various agencies for the advancement of agriculture which exist in the Dual Monarchy, and to deal generally with what may be called the administrative side of the question.

The actual practice of agriculture in the country is less easy to describe in general terms. It is of every grade of merit and

---

<sup>1</sup> *Journal*, Vol. I. (3rd Series), 1890, pp. 673-709.

every degree of intensity; and it would of course be impossible to give, within the limits of the pages of the Journal, any full-length description of the varieties of cultivation, crops and live-stock in an Empire four times the size of England and Wales, with every sort of soil, climate, altitude—an agglomeration of twelve or more different races, with the physical and mental characteristics of the Teuton, Czech, Magyar, Italian, Pole, Russian, and Turk. Such a description, even if room could be found for it, would not be of much value to the British farmer, since the circumstances of different countries and nationalities vary so greatly that it might not be wise for him to copy in England methods of cultivation found successful in Alpine valleys or Hungarian plains.

There is, however, one important agricultural industry in Austria-Hungary that has at the present moment a very particular interest for us in this country, now that renewed efforts are being made to draw public attention to the manufacture of home-grown sugar; and it occurred to me, therefore, that it might be useful if, whilst I was in Austria on the business of the International Agricultural Congress last autumn, I made a special investigation on the spot into the cultivation of the sugar-beet. Mainly through the good offices of Chevalier Max. von Proskowitz, the indefatigable Honorary Secretary of the Congress, to whose cheery companionship and never-failing forethought I owe most of the pleasure of my visit, I was enabled to make under the most favourable auspices a detailed inspection of two typical sugar factories and a number of beet farms in Northern Austria, at Lundenburg and Wischau respectively, and to collect much of the information summarised in the following pages.

At Lundenburg I inspected eight separate farms of a total area of 7,050 acres, which are under the personal management of Herr Kuffner, the proprietor of the sugar factory; and at Wischau ten farms of a total area of 5,800 acres, which are under the control of the Company owning the factory. At this last factory, 40,000 tons of beet-root are dealt with annually, and 300 workmen are employed, excluding the labourers on the farms.

#### THE BEET-SUGAR INDUSTRY ON THE CONTINENT.

In the discussions which have of late taken place as to the possibility of growing sugar-beet in this country, the allegation has been made that the system of bounties practised by foreign nations is the only real impediment in the way of its profitable

cultivation in the United Kingdom. It is undeniable that equally good sugar-beets can be raised in England as on the Continent; and if countries like Holland, Belgium, and Northern France, with climates very similar to our own, can grow beet successfully, there appears no valid reason from the agricultural point of view why we should not have home-grown sugar. The crux is, Can we grow it at a profit, in view of the competition of bounty-fed sugar from abroad? This it would be foreign to my present purpose to discuss. Moreover, the question of bounties is one of high complication, and a recent attempt by our Government to deal with it by an International Convention met with disastrous failure.

The augmented consumption of sugar by the people, the remarkable changes in its countries of origin, and the extraordinary increase in the production of beet sugar as compared with that from cane, are all facts of extreme economic importance. It is not perhaps generally recognised that whereas thirty years ago beet sugar only represented about one-fifth of the total production of the world, it now represents more than a half. The subjoined table<sup>1</sup> shows this very strikingly, though it must be stated that 1889-90 was an exceptionally favourable year for beet-roots:—

*The World's Production of Sugar during the last seven Years.*

Year	Beet sugar	Cane sugar	Total production
	Tons	Tons	Tons
1883-1884	2,361,000	2,323,000	4,684,000
1884-1885	2,546,000	2,351,000	4,897,000
1885-1886	2,220,000	2,340,000	4,560,000
1886-1887	2,730,000	2,345,000	5,075,000
1887-1888	2,452,000	2,470,000	4,922,000
1888-1889	2,765,000	2,280,000	5,045,000
1889-1890	3,500,000	2,278,000	5,778,000

It is seen from the above table that the production of cane sugar has remained stationary or even diminished during the last septennial period, while the production of beet sugar has greatly increased.

Austria is the second largest producer of beet sugar in the world. The subjoined summary shows in tabular form the figures for the different continental countries for the last four completed years or "campaigns," and for the present campaign of 1890-1, as estimated by the well-known expert, Mr. F. O. Licht of Magdeburg, and is self explanatory.

<sup>1</sup> *La Sucrerie Indigène*, March 11, 1890, p. 232.

*Production of Beet Sugar on the Continent of Europe for the last five years.*

Country	1890-1891	1889-1890	1888-1889	1887-1888	1886-1887
	Tons	Tons	Tons	Tons	Tons
Germany . . . .	1,335,000	1,264,607	990,604	959,166	1,012,968
Austria . . . .	760,000	753,078	523,242	428,616	523,059
France . . . .	700,000	787,989	466,767	392,824	485,739
Russia . . . .	530,000	456,711	526,387	441,342	487,460
Belgium . . . .	200,000	221,480	145,804	140,742	135,755
Holland . . . .	65,000	55,813	46,040	39,280	36,098
Other Countries	80,000	80,000	87,000	79,980	69,127
Total . . . .	3,670,000 (estimated)	3,619,678	2,785,844	2,481,950	2,750,206

Of the countries named in this table, Germany is a very considerable exporter to other countries, especially to England, the German product representing about two-thirds of our total imports of beet sugar. Austria is the next largest exporter, its sugar going mainly to Mediterranean countries and the East, but some of it coming to England *via* Germany.

The growth of the beet sugar industry on the Continent since it first became of economic importance is well shown in the following table, extracted from a valuable paper by Dr. O. J. Broch on *Les Excitants Modernes*.<sup>1</sup>

*Production of Sugar-Beet on the Continent of Europe.*

Average of years	Germany	France	Austria-Hungary	Russia	Belgium	Holland	Other countries	Total in Europe
	Tons	Tons	Tons	Tons	Tons	Tons	Tons	Tons
1836-9	5,700	42,400	1,000	—	—	—	—	49,000
1840-4	13,900	27,800	3,300	—	—	—	—	45,000
1845-9	15,000	40,000	4,000	—	—	—	—	59,000
1850-4	70,200	68,300	15,600	11,200	8,000	—	—	174,000
1855-9	104,300	117,200	41,000	40,000	14,100	—	—	317,000
1860-4	112,400	137,700	62,300	60,000	19,500	—	—	422,000
1865-9	195,500	238,900	76,900	175,000	36,700	—	2,000	725,000
1870-4	251,900	376,100	111,200	200,000	70,000	—	6,000	1,015,000
1875-9	311,600	362,800	300,000	320,000	66,200	20,000	10,000	1,420,000
1880-4	667,400	406,000	478,000	281,000	75,000	20,000	10,000	1,940,000
1885-9	991,000	402,000	471,000	476,000	121,000	35,000	51,000	2,547,000

## THE SUGAR-BEET INDUSTRY IN AUSTRIA.

The cultivation of the sugar-beet in Austria on anything like a large scale dates back about sixty years, but it has especially

<sup>1</sup> *Bulletin de l'Institut Internationale de Statistique*, Tome II. 1887, p. 240. (The figures for the last quinquennial period have been calculated by myself.)



developed during the last half of that period, as shown in the following table :—

	1830	1860	1870	1880	1888
Number of factories	100	125	215	227	215
Tons of beet used	490,000	1,430,000	3,300,000	4,700,000	6,000,000

On the average of the ten years 1879–88, 494,000 acres in Austria were devoted to the cultivation of sugar-beet, of which 318,000 acres were in Bohemia and 150,000 in Moravia. The annual yield during the same period was 3,750,000 tons, or an average of rather more than  $7\frac{1}{2}$  tons per acre (in some parts of Bohemia 10 tons).

Olivier de Serres, in his writings of 1590, makes mention of the red beet as having only recently been introduced into Europe, and as yielding a juice which “on boiling is similar to sugar-syrup.” But the root does not seem to have been considered as having an industrial value, and was cultivated only for the table or for cattle food, until 1747, when Margraff, a member of the Berlin Academy of Sciences, believing sugar to be a regular constituent of plants other than the sugar-cane, made examination of different varieties of vegetables, and succeeded in separating from several kinds varying quantities of crystallisable sugar, beet being found to be the richest. This important discovery, however, remained dormant for nearly half a century, when one of Margraff’s pupils, Karl Franz Achard, director of the Academy of Sciences at Berlin, again took up the line of research started by his preceptor, and finally succeeded in extracting sugar from the root on a comparatively large scale. Prior to this, sugar had been obtained exclusively from the sugar-cane, and was for the most part produced in the colonies of the different countries, though in all cases refined in Europe.

The first attempts in Austria to obtain sugar from various native plants had been made by Professor Jaquin in Vienna as early as 1799, and by Dr. Ries in St. Pölten in 1803. Conrad Adam in Vienna carried out experiments with the beet on a larger scale; he settled in Harowitz in 1800. The first great success was not, however, obtained with the beet as a producer of sugar, but with maple-juice—a method which was first introduced on the estates of the Prince of Liechtenstein at Eisgrub.<sup>1</sup> Even this effort led to no permanent result, for it soon appeared that the beet was the most fitted for the production of native sugar; and when, in consequence of the decree of the Emperor Francis I., dated January 14, 1831, the production of sugar from

<sup>1</sup> A charming spot near Lundenburg, with extensive forests and a magnificent palace, visited by me in the course of my inspection.

beet was relieved of the payment of industrial taxes during a period of ten years, the manufacture of beet sugar became finally and firmly established in Austria.

The first Austrian beet-sugar factory was erected at Dobrowitz in Bohemia by Carl Weinrich, by order of Prince Thurn and Taxis; in the same year factories were built in Moravia at Kirchwidern, in Lower Austria at Staatz, and in Galicia at Krzywczwyce, near Lemberg. The first undertaking of the kind in Silesia was in 1832 at Ober-Suchau.<sup>1</sup> Except the factory in Dobrowitz, none of those above mentioned are still in existence; but they had many vigorous successors, and, according to the latest statistics, there were 215 factories at work, of which 136 were in Bohemia, 49 in Moravia, 9 in Silesia, 3 in Lower Austria, 1 in Galicia, and 17 in Hungary. The beets used for sugar weighed, in 1888, six million tons; the sugar produced weighed 750,000 tons, and of this there was exported 450,000 tons.<sup>2</sup>

For a long series of years, a tax has been levied on sugar in Austria; and the particular method of its being levied has been the subject of much debate and many changes. A law of 1865 replaced a former system of duties on the actual weight of the beet by theoretically fixing the yield of the quantities of beet used. But it was found that the actual yield was often more than the legal yield, so that a quantity of sugar escaped taxation, and improvements in manufacture accentuated this advantage to the makers.

Further laws were passed in 1878 and 1880, the last of which fixed an excise duty equal to 8*d.* per cwt. of fresh beet, and granted a drawback of about 10*s.* for every cwt. of sugar exported.

The incidence of this duty gave rise, however, to dissatisfaction, and the two Governments of Austria and Hungary submitted therefore to the Chambers, in 1887, a new law which

<sup>1</sup> More detailed information as to the history and development of the Austrian sugar industry appears in a Pamphlet, entitled: *The Technical Development of the Sugar Industry in Austria*, by F. Strohmayer (Vienna, 1890), published by the "Centralverein für Rübenzucker Industrie."

<sup>2</sup> Amongst other "agricultural industries" of Austria may be mentioned 47,708 distilleries, producing in 1888 nearly 20 million gallons of proof spirit; 100 maltings, besides those at breweries; and 1,835 breweries, 772 of which were in Bohemia. There were brewed in Austria in 1888 very nearly 300 million gallons of that light beer so much affected by the population. Pilsen in Bohemia gives its name to a beer which has come to be regarded in England as typical of the beverage drunk in such quantities in all German and Austrian towns; but most of the Austrian beers have a mild and soft taste, and Pilsener has a strong—almost medicinal—bitter flavour, due to the far-famed Saaz hops, grown in the vicinity.

came into force on August 1, 1888.<sup>1</sup> This law abandons the whole previous system, and makes the actual produce the basis for the levying of the duty. In place of a tax on the raw material, the amount of sugar produced is subject to tax at the rate of 11 florins per 100 kilos. (about 9s. per cwt.); and instead of the drawback allowances on export, a direct bounty on exportation is granted at the following rates:—

				<i>s.</i>	<i>d.</i>	
(a)	Sugar polarising	99.5 and over	. . .	2	4	per cwt.
(b)	" "	93 to 99	. . .	1	7½	"
(c)	" "	88 to 93	. . .	1	6¼	"

It has been further provided that if the export bonus during the producing season, *i.e.* from August 1 to July 31 of the following year, should exceed 5,000,000 fl. (417,000*l.*), such excess amount must be refunded to the Government *pro rata* by the sugar producers.

This law was much criticised at the time, being regarded as a concession made to the powerful sugar interests, and it was argued that a subsidy of 5,000,000 florins annually was thereby granted to the 200 sugar manufacturers of Austria, at the expense of the community. The Finance Minister, however, declared that "it was, as a matter of principle, correct that bonuses or premiums should not be granted, but that it was, on the other hand, an undoubted fact that so long as other States accorded bonuses, the beet-root sugar industry could not subsist without similar support."<sup>2</sup>

#### AXIOMS OF SUGAR-BEET GROWING.

In a report presented by Dr. Wm. McMurtrie to the Department of Agriculture at Washington in 1880,<sup>3</sup> the axioms of sugar-beet growing are very succinctly stated in the subjoined words, which I make no apology for adopting as the text of the more detailed observations on the subject contained in the following pages :

Choose well-drained, permeable soils, not overcharged with nitrogenous, organic, or soluble mineral matters. Choose the best qualities of seed.

<sup>1</sup> See Parliamentary Papers respecting International Conference on Sugar Bounties, C. 5259 of Session 1888, p. 104, and C. 5260, p. 71. See also observations of Count Kuefstein at the second sitting of the Conference, Nov. 28, 1887 (C. 5260, p. 102).

<sup>2</sup> Mr. Phipps to the Marquis of Salisbury, Vienna, Nov. 2, 1887. Parliamentary Paper C. 5259 of 1888, p. 81.

<sup>3</sup> *Report on the Culture of the Sugar-Beet*: By William McMurtrie, E.M., Ph.D.; agent and representative of the United States Department of Agriculture at the Paris Exposition of 1878. Washington, 1880.

Give preference to smaller seeds. The best beets for all purposes are long, tapering, and smooth; do not grow out of the ground; are of moderate size; and are dense and heavy. Plough deeply and as frequently as may be necessary to make the soil mellow. The more it approaches that of a garden in physical condition, the more favourable it will be for culture of the beet.

Be careful in choice of manures to be employed. Remember that insoluble and not easily assimilable nitrogenous organic compounds, before they can be of use to the crop, must be thoroughly disintegrated and decomposed. They must therefore be applied sufficiently in advance of the crops to secure this effect. Soluble nitrogenous compounds may be applied immediately in advance of, or simultaneously with, planting; and of these the nitrates are preferable. Nitrogenous compounds have a tendency to extend the period of growth, and delay the time of ripening. This tendency is counteracted by the phosphates, in consequence of which they increase the production of sugar.

Stable manures must in all cases be worked into the soil with the autumn ploughing. Do not apply more than 10 to 15 tons per acre, and supplement it with nitrate of soda and superphosphate of lime at the rate of from 200 to 400 lb. of each per acre, according to the character of the soil.

Alkaline salts should be applied with great caution, and only to soils manifestly wanting them. They add to the cost of culture, and often reduce the industrial value of the crop.

Plant closely. Separate the beets by about 8 inches in the row.

Cultivate early and often, and continue as long as the leaves will permit, but not longer than the middle of July. Do not harvest until the crop is thoroughly ripe, but it must not be allowed to be injured by frost.

Store the roots in such a way that they may be protected from extremes of temperature and moisture, and observe care in ventilating trenches or cellars; otherwise the roots will rapidly deteriorate.

### SOILS ADAPTED FOR SUGAR-BEET.

Experts are not altogether agreed as to the soil best adapted for the beet, but it may be stated generally that the physical characteristics of the soil which tend to render it best suited to the cultivation of the beet are porosity of surface and subsoil, to admit of drainage of superfluous water and of free circulation of the air, and power of absorbing and holding in a condition convenient for ready assimilation the elements of plant food existing within it or coming from external sources.

The climate most suitable for beet-growing is a moderately warm one, with a sufficiency of moisture. The plant does not thrive in rough mountain regions. Its quality improves in dry years, but wet years are favourable to its gross produce. Rain in July and August gives weight, but a dry September gives sugar.

Beet will thrive upon almost any soil which is well cultivated, but especially prefers a deep, moist, loamy soil, containing chalk and marl. A good mangel, turnip, or potato soil is

excellent for the purpose, provided it contains plenty of lime. It is essential that the soil should be capable of deep cultivation, as the plough must penetrate to a depth of 8 to 10 inches, and the subsoil plough 6 inches below that. The roots must be buried almost entirely in the ground to yield their full proportion of sugar, and must penetrate freely into the subsoil if they are not to be stunted and to run too much to tops.

There is no soil so well suited for beet as a good, well-worked, deeply cultivated, and thoroughly drained clay-loam; or, in other words, a soil containing a good deal of clay, with a fair proportion of sand. On calcareous soils the roots are generally small, rich in sugar, and yield a juice of great purity.

Most good clay-loams contain sufficient lime to meet the requirements of the beet-root crop. Many light soils, on the other hand, being poor in lime, are much improved by the application of clay, marl, chalk, or quicklime previous to ploughing up the land in autumn.

The subsoil has an important influence on this, as on all root crops. It should be sufficiently friable to allow the ready penetration of the roots, and be thoroughly well drained; for it is vain to hope to grow successfully good sugar-beet on land resting on a stiff, cold, and partially drained subsoil. In dealing with rather heavy land particular attention has to be paid to autumn cultivation. Deep ploughing in autumn and stirring the subsoil without turning it up, and above all steam cultivation—much practised by the large factories in Austria—are some of the means of preparing such land for beet roots. "In short," says the late Dr. Voelcker in a report on the subject in this *Journal*,<sup>1</sup> which I have laid largely under contribution, "the same rules which apply to the proper cultivation of the soil for other root crops should guide the farmer in preparing his land for sugar-beets."

Too much stress cannot be laid upon the necessity of carefully choosing and properly preparing the land intended for the cultivation of sugar-beet. To obtain long, clean, properly shaped roots, the plants must have a sufficient depth of soil to grow in, as nothing fosters the development of side roots more than the stoppage of the passage of the tap root by the hardness or bad quality of the subsoil.

#### PLACE OF THE BEET ROOT IN THE ROTATION.

The most suitable preparation for sugar-beet is a white straw crop, or well-manured potatoes. Wherever possible, beet is

<sup>1</sup> *Journal R. A. S. E.*, Vol. V. (2nd Series), 1869.

made both to follow and precede a corn crop. Clover or "seeds" should not precede beet, for although the roots grow to a large size and yield well after clover-seeds, they remain poor in sugar and take up too much saline matter from the decomposing remains of the preceding crop. Beet is usually followed by spring wheat. All experience points to the fact that repeated sowing of beet on the same land is ruinous to the cultivator, even where immense quantities of farmyard manure are applied, and where a return is made to the land of all the constituents taken from it by the beet.

At Lundenburg, the following two sorts of rotations were found, one applied to the heavier soils, and the other to the lighter soils.

*Heavier Soils.*

- (a) Winter or summer wheat, with dung;
- (b) Sugar-beet with artificial manures.
- (c) Barley.
- (d) Rye or Lucerne.

*Lighter Soils.*

- (a) Rye, with dung.
- (b) Sugar-beet, with artificial manures.
- (c) Barley or Oats.

At Wischau the rotations were found to be more elastic and to be varied according to circumstances, although alternations were carefully observed. The most common rotations are :

- I. (1) Autumn-sown cereals, (2) Sugar-beet, (3) Barley, (4) Sugar-beet, (5) Barley, (6) Clover, Peas, &c.
- II. (1) Autumn-sown cereals, (2) Sugar-beet, (3) Barley, (4) Clover.
- III. (1) Autumn-sown cereals (2) Sugar-beet, (3) Barley, (4) Sugar beet for seed, (5) Autumn-sown cereals (6) Sugar-beet, (7) Clover.
- IV. (1) Wheat, (2) Sugar-beet, (3) Barley, (4) Peas, (5) Autumn Rye, (6) Sugar-beet, (7) Barley, (8) Sainfoin, (9) Sainfoin and sometimes (10) Sainfoin.

"The fundamental principle of the cultivation," says M. Gustav Skutezky, the manager of this estate, "is to grow by judicious alternations those plants which promise the greatest yields. We abandon the regular fixed rotation after due consideration of the weather and the preparedness of the soil, in cases where the sowing cannot be made under the most advantageous conditions."

VARIETIES OF BEET MOSTLY IN USE.

All kinds of sugar-beets are botanically identical with the common garden beet, *Beta vulgaris*. The differences in varieties have arisen by reason of special selection and culture, producing a pure strain of some valuable peculiarity in the beet.

These accidental valuable qualities, by careful selection, have become fixed, and are associated with certain external properties which have thus come to be regarded as distinguishing characteristics. The shape and size of the beet, its colour, the character of the foliage, whether erect or spreading, &c., are the most frequent marks of distinction. The varieties are frequently designated by the names of those who have developed them, or by the name of the town or locality in which they have been grown, or by their colour.

The importance of proper selection of the variety or race of the beet to be grown for sugar is strongly insisted upon by all writers on the subject. A beet giving a large cultural yield, rich in sugar, involves no more cost to the grower in its production than one giving a small yield and low saccharine value. It is therefore desirable to choose those varieties which will give the largest returns, and be at the same time the most satisfactory in every way to the grower who has to produce them, and to the manufacturer who has to extract the sugar.

Experience shows that roots of moderate size yield a juice which contains a smaller percentage of mineral and organic impurities and affords a greater yield of sugar than larger ones; and it appears to be regarded almost as an axiom that the smaller the beet the richer in sugar.

Up to a certain point, this is true. The great richness in sugar of a beet depends upon the absence of zones of purely cellular tissue, and the predominance of fibrous tissue more dense and more slowly formed. But it is not less true that between roots of the same richness, there may exist considerable differences of weight and size, and the great object of the improved varieties is to harmonise as far as possible the qualities of cultural yield and industrial value.

Quality being so important a feature in the cultivation of the beet, the utmost care is taken to sow only those varieties that can be relied upon for good results; and to the selection and improvement of seeds, having these characteristics, an enormous amount of care and study has been devoted by scientists, seed-merchants, and producers.

When the question of sugar-beet growing in England was first brought prominently forward by Mr. Duncan's bold but unsuccessful experiment at Lavenham, about twenty years ago, the kind of beet most in favour with Continental growers was the Silesian (see Fig. 1), on account of its free yield of roots and vigorous growth. The interest of this kind is now, however, little more than historical; for in the course of the last twenty years it (with its sub-varieties of Magdeburg, Breslau,

Imperial, Electoral, and the like) has gone almost completely out of cultivation in favour of newer, richer, and more prolific descendants of the old Silesian stock, the most famous of which are the White Improved Vilmorin, and the Klein-Wanzleben.

The White Improved Vilmorin beet, though originally a French variety (being called after the well-known seed firm of Vilmorin, Andrieux & Co., of Paris), has a great reputation all over Central Europe, and the quantity of it annually distributed is immense. I found it in use at all the sugar factories I visited in Austria, and highly spoken of for its exceptional richness, its great purity, and its good keeping qualities. Originally descended directly from the old white Silesian beet, it has been the subject of careful and persistent cultivation for considerably

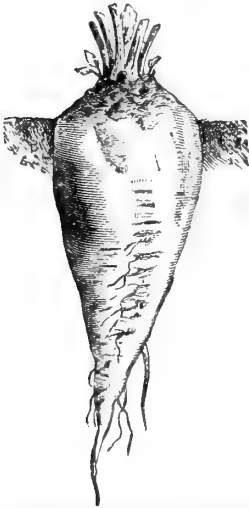

FIG. 1.—The Silesian Sugar-beet.



FIG. 2.—The White Improved Vilmorin Sugar-beet.

over thirty years, with the result that its qualities of richness and purity have now become fixed and constant. Some thousands of analyses have shown it to yield up to as high a proportion of sugar as 16 per cent. of the weight of the roots,  $1\frac{3}{4}$  lb. of sugar per gallon of juice being a very ordinary yield with it.

A density of the juice of from 1.075 to 1.080, which corresponds to a proportion of 14 to 15 per cent. of sugar in the root, is quite common. The average crop is from 12 to 14 tons of roots per acre, but over 16 tons of excellent roots are not infrequently obtained.

The particular characteristic of the Vilmorin beet is the



predominance of fibrous or sugar-bearing tissue, which gives to the flesh a greyish tint. Its appearance is well shown in Fig. 2. Two qualities of high value which it possesses are those of not deteriorating under conditions which are habitually injurious to the richness of sugar-beets (such as acid soils, the application of certain manures, and the like) and its excellent keeping qualities. Where several varieties of beet are grown, it is often the practice to reserve the Vilmorin beets to be pulped last, as being those that lose and spoil the least by keeping.

The other variety of beet which is most extensively cultivated, particularly in Germany and Austria, is the Klein-Wanzleben — so called from the town (near Magdeburg) where its seed is chiefly cultivated. This has a straight, conical root, often large at the top and rapidly tapering (see Fig. 3). It is distinguished from the Vilmorin variety by the clearer and paler colour of its leaves. It succeeds best in alluvial soils of moderate fertility, and in the plains; in lands very rich in humus, it ripens badly, and loses much of its richness. Under suitable conditions of climate, it yields an even more luxuriant crop than the Vilmorin, giving easily 14 tons in ordinary soils, and exceeding 16 tons in very favourable circumstances. Up to as much as 15 to 16 per cent. of sugar is obtainable from it, and under specially favourable circumstances even more.



FIG. 3.—The Klein-Wanzleben beet.

At Wischau, Klein-Wanzleben was found to be the variety chiefly used, as uniting a high polarisation to a satisfactory yield per acre. Herr Skutezky said that, "in view of the sugar-tax, the selection of Klein-Wanzleben is made in consideration of these two incomparable qualities, as it is necessary to satisfy both manufacturers and cultivators."

In the paper by Dr. Augustus Voelcker, already alluded to

as having been published in this Journal in 1869, he thus defines the characteristics of a good sugar-beet; and though improvement has steadily progressed in the plant since he wrote, his words still hold good:

1. Good sugar-beets have a regular pear-shaped form.

2. They do not throw out many fibrous-branched roots or forks. Forked roots are difficult to clean, and not so readily pulped as well-grown symmetrical pear-shaped roots.

3. They have a white, firm, and dense flesh, and clean sugary taste. Soft and spongy thick-skinned roots are always more watery than beets of a uniformly firm, hard, and close texture.

4. They should generally weigh from  $1\frac{1}{4}$  to 2 lb. Very small or very large roots are not usually well suited for the manufacture of sugar. Roots weighing under  $\frac{3}{4}$  lb. are frequently woody, and besides sugar contain too large a proportion of other constituents, which prevent in a large measure the extraction of crystallised sugar from the juice, whilst roots weighing more than  $2\frac{1}{2}$  lb. are generally too watery and too poor in sugar.

5. They should always have small tops, and no tendency to become necky.

6. Such roots do not show much above ground, but grow almost entirely in the ground. Roots, the tops of which grow above ground, do not yield so much sugar as others that bury themselves better in the soil, for the heads of the roots, being exposed to light, turn greenish, and yield less crystallisable sugar than the parts covered by the soil. Manufacturers of sugar cut off the greenish-coloured heads of the roots before they are pulped, and hence much waste takes place when beet roots grown in a large measure above ground are sent to the manufactory.

7. Generally speaking, the higher the specific gravity of a beet root, the more it is esteemed for its sugar-producing qualities. Good roots are considerably more dense than water, and rapidly sink to the bottom of a vessel filled with water.<sup>1</sup>

8. The expressed juice of good beet-roots has a clean, sweet taste, and a specific gravity of from 1.060 to 1.070. When very rich in sugar, the specific gravity of the juice rises above 1.070, reaching occasionally 1.075 to 1.078.<sup>2</sup>

#### BEE T ROOTS FOR SEED.

The production of seed is one of the most important operations connected with the sugar-beet industry. On the care and skill which are displayed in this process depend the maintenance and improvement of the sugar-producing qualities of the beet. The beets which are to be preserved for seed are called "mothers," and are carefully stored in the manner explained afterwards. They are selected at the time of harvesting from specially grown beet, or from fields of beet which have shown

<sup>1</sup> The fact that a root does not sink in a liquid of given density is, however, no sure proof of its bad quality, since in most roots a cavity in the neck exists which is full of air and of extremely variable size. It may cause very rich roots to float when they would sink if solid.

<sup>2</sup> In consequence of the increased richness in sugar, the specific gravity is now at its best, 1.080 to 1.090.

particularly good qualities on analysis.<sup>1</sup> The weight of the roots selected for mothers should be about the average of the best sugar-beets, from 20 to 24 ounces. Smaller beets than these would show a higher percentage of sugar, but it is not wise to produce a race of small beets by selecting the seed from the very smallest and richest beets grown. The size of the "mothers" having been decided, the beets are next selected for their shape and external appearance. Those regular in shape and smooth in external form are preferred. Roots of irregular shape, or with more than one tap-root, should be rejected.

The beets to be preserved for seed are harvested with unusual care to avoid injury. The neck is not cut away, but the leaves are removed by cutting off the stems without injuring the neck of the beet. The clamping should be of such a nature as to entirely protect the beets from frost, and yet prevent their growth until the spring. The beets are removed at an early date in the spring, and are immediately subjected to analysis for the final selection.

At Wischau, I found a prominent feature was made of the cultivation of beet for seed. The roots intended for this purpose are chosen every year in a special laboratory, with the guidance afforded by the polarisation of the juice. Well-formed roots are first selected in the fields in the autumn, and are again examined in the spring, when they are weighed. Any root of less than  $1\frac{1}{2}$  lb. is rejected. With an instrument not unlike a cheese-borer a small cylindrical piece is taken out of each beet weighing over  $1\frac{1}{2}$  lb., and its specific gravity tested.

About 40 per cent. pass this test, and are sent for more complete examination to the laboratory. There another but larger cylindrical piece is bored obliquely out of the beet, and its juice is examined with the polariscope to ascertain what percentage of sugar it contains. From the best of those with a high polarisation, the roots weighing over  $1\frac{3}{4}$  lb. are selected to form the very best class, "Supra élite."

In 1890, 18,068 beets were selected at Wischau by the specific gravity test for further examination, two chemists and fourteen other persons being employed in this operation. Of this number of roots 333, or 1.84 per cent., were classed as "Supra élite"; 6,865, or 37.977 per cent., as "Elite," and used for the cultivation of the finest seed; 6,716, or 37.10 per cent., as second

---

<sup>1</sup> Messrs. Rabbethge and Giesceke, the famous cultivators of the Klein-Wanzleben variety, who have been growing beet for seed for upwards of thirty years, state that in 1889-90 they tested 2,782,300 roots, from which they selected 3,043 roots, equal to 0.1 per cent., for seed-growing purposes.

quality, used for seed to sell; and 4,154, or 23 per cent., as third quality, and discarded.

The cultivation of sugar-beet for seed has reached such a stage of perfection that it is easy to modify the root according to the needs or wishes of the producer; and as a consequence a large number of growers are accustomed to produce for themselves, either in whole or in part, the seed which they need. Seed-growing requires, however, so much attention, trouble, and organisation, that the seed is usually purchased from the firms of merchants who devote themselves to beet-seed cultivation.

Austria has perhaps been rather behind France and Germany in its cultivation of special improved varieties of beet seed, and has been content to import seed from foreign nations. But there are a few scientific growers of beet for seed in Moravia who have a high reputation for their products, foremost amongst whom must be placed Chev. Em. von Proskowetz, Junr., of Kwassitz, and Herr Jirku, of Birnbaum.

#### SOWING.

The field in which beet is to be sown should, as already indicated, be ploughed in the autumn to the depth of from eight to ten inches. The plough in each furrow should be followed by a subsoiler, which will loosen the soil to the depth of about six inches more. Each field should thus have the soil prepared by thoroughly loosening it to the depth of from fourteen to sixteen inches.<sup>1</sup> The land being exposed through the winter becomes quite mellowed, and in the spring can be got ready by a simple preparation of the surface. This should be done by a thorough cultivating until the surface of the soil is reduced to perfect tilth.

The season for sowing extends from the beginning of April to the first week in May. Sown too early in spring, the roots are very apt to run to seed during growth, especially if spring frosts should set in, and if the sowing be delayed too long, the crop may not get fully ripe before it has to be taken up. The best time for sowing is considered in Moravia to be the middle of April (from April 10 to 20), when the thermometer should range between 50° and 60°; for at this temperature the seed will germinate most surely and most rapidly. Under ordinary

<sup>1</sup> In some of the better soils of Austria, as at Wischau, which is situated in the wonderfully fertile valley of the Hanna, the soil is ploughed with the steam-plough to the depth of fourteen or fifteen inches: the subsoiler being only used on lighter lands, where it is desired to avoid bringing up obnoxious matter from below.

circumstances the steeping of the seed in water is dispensed with, but occasionally the steeping of the seed for twelve hours in water at a temperature of 120° Fahr. advances the growth of the plant.

The quantity of seed sown rises to as much as 31 lb. per acre. It is only by this liberal use of seed that a sufficiently close crop can be assured, especially under unfavourable conditions as to weather, &c.

The distances between the drills and between each plant are regulated according to the various agricultural conditions in which the land may be. The better the soil the closer the roots may be grown. If grown too far apart on good land, the beet roots become larger, but remain poor in sugar; and, on the other hand, planted too near each other, the roots get rich in sugar, but remain small, and the value of the produce in either case is less than when both extremes are avoided.

Fifteen years ago the usual width between the rows was sixteen inches. Some estates in Austria tried for a few seasons fifteen inches and then fourteen inches; but nearly all have eventually returned to fifteen or sixteen inches, which is the width generally adopted. With this distance, the roots may be separated from each other by about eight inches in the rows.

For the sowing of the seed, specially designed drills are customarily used; but any drill that will deliver the seed regularly and in sufficient quantity will answer every purpose. The seed is either drilled in lines, or is dibbled. Machines, too, are used, though not so commonly, that distribute at the same time pulverised artificial manures; but these are being discarded in favour of broad-casting machines. The seed should be covered to the depth of from half an inch to one and a half inch, according to the condition of the soil. If the soil be moist and in good condition, the seed should not be covered more than half an inch. If, on the other hand, the soil be very dry, it should be covered to the depth of one and a half inch. After the sowing, a Cambridge roller is passed over the field.

#### CULTIVATION.

As soon as the plants are large enough to show in the rows, cultivation with the horse or hand hoe should be commenced. A good deal of the hoeing is done by hand; but there is a great variety of hoeing-machines in the market, from the simple and primitive implement shown in Fig. 4 to the highly elaborate compound machines sent out from the works of such makers as Clayton and Shuttleworth at Vienna, Rudolph Sack of Leipzig,

or the Schlick Company of Buda-Pesth. Illustrations of an implement which combines in itself the functions of a drill, a hoe,

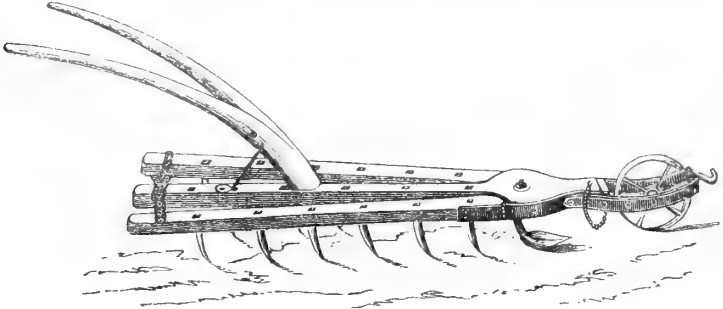

FIG. 4.—One-row Horse Hoe.

and a moulder or ridger, are shown in Figs. 5 and 6, the different appliances being fitted to the frame of the machine according to the use to which it is to be put.

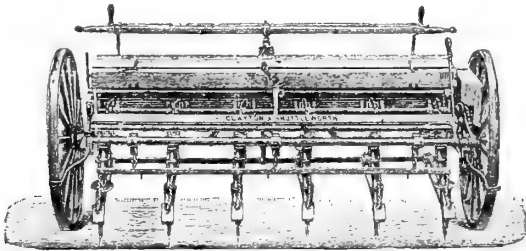

FIG. 5.—Combined Drill and Hoe, &c., shown as a Drill.

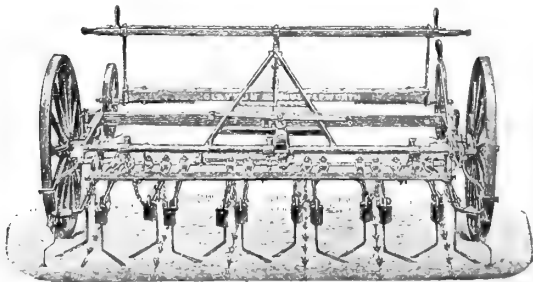

FIG. 6.—The same, shown as a Hoe.

When the plants show four leaves the process of thinning should take place. If the rows be sixteen inches apart, a vigorous plant should be left every eight inches. Careful selection

should be made and all the puny plants destroyed. It is better to save the vigorous plants even if regular intervals are not preserved, but no space should be left greater than twelve to fifteen inches in extent. Much of the thinning can be done by a narrow hoe, but where the plants are very close together, at the place where the plant to be preserved is to grow, the work must be done by hand. It is well to give a thorough hand-hoeing at the same time, and the subsequent cultivation, in most seasons, may be carried on with horse power.

When the plants are more advanced a few deeper cultivations may be desirable, and for these any good cultivator may be used. The cultivation in all cases should be conducted for the two-fold purpose of keeping the crop entirely free from weeds, and for preserving a proper tilth of the surface of the soil. At least once a fortnight during the period of growing the beet field should be cultivated. If the season be very dry, more frequent cultivation will be found useful. The final cultivation should leave the soil practically level. During cultivation care should be taken not to injure either the leaves or the root of the beet; and when the foliage of the growing crop begins to cover well the surface of the soil cultivation may be suspended.

The cultivation of the beet, like that of the mangel and of root-crops generally, consists, in fact, in timely and careful thinning, weeding, and keeping the soil in a loose and friable state, by means of the harrow and the horse- or hand-hoe. As long as the young plants are not injured by hand-hoeing, the repeated application of the hoe from time to time is attended with the greatest benefit to the crop.

#### MANURES AND MANURING.

Next to the soil, manure has a powerful influence on the quality of sugar-beet. If possible, beet should not be grown in freshly dunged soils, though with the improved varieties and on good land this is not now considered so injurious as it used to be in rendering the roots poor in sugar and overcharged with saline matters. The presence of an excess of saline matters in the juice of the beet is much dreaded by the manufacturer of sugar, inasmuch as it largely prevents the extraction of the sugar in a crystallisable state.

If the soil, however, is very poor, it is impossible to grow anything like a crop without manure; in that case farmyard manure must be applied to the land in autumn, or 3 or 4 cwt. of guano, or a mixture of guano, bone-dust, and superphosphate

and sulphate of potash. Peruvian guano has been used with advantage for beet on naturally poor soils, and when applied in moderate quantities in autumn it greatly benefits this crop.

Ammoniacal salts, guano, rotten dung, and in general all nitrogenous manures, require to be used with discrimination, for their tendency is to encourage the luxuriant growth of tops, and to diminish the percentage of sugar in the roots. A certain amount of available nitrogen in the soil appears to be necessary for the healthy growth of the sugar-beet, and hence the use of guano or animal manures cannot be dispensed with when the soil on which the crop is intended to be grown is either naturally very poor, or out of condition by repeated cropping. On the other hand, nitrogenous manures, such as guano, sulphate of ammonia, or rotten dung, should not be applied to beet when the land is in good heart. For soils in good agricultural condition an extra supply of nitrogenous organic matter or ready formed ammonia does harm, inasmuch as, though it produces a very heavy crop, it both diminishes the percentage of sugar in the roots, and prevents the manufacturer obtaining, in a crystallised form, as large an amount of sugar as he can produce from beet containing the same percentage of sugar, but grown without the use of nitrogenous manure.

Superphosphate of lime may be applied to the land with excellent effect at the time when the seed is drilled in. Bone-dust also does good. On light soils, in which potash is generally deficient, a mixture of superphosphate and sulphate of potash has been found most serviceable to beet in many cases, not only upon light sandy soils but upon all soils in a comparatively poor agricultural condition.

The constituents to be taken into account in the necessary restitution to the soil for the growth of beet are potash, phosphoric acid, magnesia, and nitrogen. The quantities of these constituents in 1,000 lb. of beet and beet leaves, averaged from numerous analyses, are as follows:—

Constituents	Roots lb.	Leaves lb.
Potash . . . . .	3·3	6·5
Phosphoric acid . . . . .	0·8	1·3
Magnesia . . . . .	0·5	3·0
Nitrogen . . . . .	1·6	3·9
Total ash . . . . .	7·1	18·1

Of all these fertilisers, that which combines in itself in the highest degree all the elements of plant food, and which is naturally the most economical, is farmyard manure. To provide the necessary dung, as well as to eat up the refuse pulp



after the sugar has been extracted from the beet, a large head of cattle must be kept. At each place visited the manure was found to be carefully preserved in large, square, bricked dung-pits, under the charge of special labourers who had no other duty. The drainings are regularly pumped up from the bottom of the pit, and distributed by hose over the surface, so as to keep the dung moist and to consolidate it. So great was the anxiety to show us everything, that for our special delectation this process was exhibited in action at each farm visited, until our olfactory nerves compelled us to cry "enough."

Care is taken that the manure is applied at a time when its fertilising qualities can most speedily assert themselves; so that it is never spread in the spring, save in exceptional cases, and then only for dressing mixed seeds, peas, oats, potatoes, or beet intended for seed. The greater part of the dung collected during the winter is not therefore applied till the month of June for the clover stubble. If the quantity of dung is not sufficient to fertilise the autumn-sown corn at this season, the cereals are manured with artificials. The manure remaining after July is reserved exclusively for beet, for which the manure should be dug in during the autumn.

At the Wischau farms, which have a total area of 5,800 acres, about 1,250 acres are manured annually with farmyard dung; and in addition the following quantities of artificials have been used during the last three years—

	1888 cwt.	1889 cwt.	1890 cwt.
Nitrate of soda . . . . .	44	52	55
Superphosphate of lime . . . . .	70	80	83
Basic slag . . . . .	7	—	7
Gypsum . . . . .	20	18	29

These manures permit of nearly all the arable land being dressed annually, in addition to the fertilisation due to the farmyard dung, which is for the most part supplemented by artificials. There is no regular rule as to these supplementary manures, which are applied according to the productive power of the different fields. Herr Skutezky supplied us with details as to the manuring of each crop, but it is only necessary to say here that the beets are fertilised with farmyard dung, with 8 cwt. of superphosphate and 4 to 5 cwt. of nitrate of soda. In cases where the roots cannot be dressed in autumn either with dung or compost, 10 to 12 cwt. of superphosphate and 6 to 7 cwt. of nitrate of soda are supplied. The beet for seed receives 6 to 8 cwt. of nitrate of soda and 10 to 12 cwt. of superphosphate. The areas manured in the last three years have been as follows:—

	1888	1889	1890
Farmyard dung . . . . .	1,042	1,289	1,308 acres
Composts, with "Saturation-Scum" <sup>1</sup> . . . . .	351	268	308 "
Artificial . . . . .	3,748	4,284	4,235 "

About 27 per cent. of the total area at Wischau was under beet, exclusive of that devoted to beet for seed; 8 per cent. to autumn-sown wheat; 2 per cent. to spring wheat; 11 per cent. to rye; 25 per cent. to barley; 3 per cent. to oats; 13 per cent. to clover and mixed seeds; and the balance to peas, lupins, potatoes and unproductive land.

Very much the same proportions were found at Lundenburg, except that beet occupied quite 30 per cent. of the ground. On this estate dung is applied every three years to the heavier soils, and every four years to the lighter soils. Artificial manures are used for the sugar-beet and sometimes also for rye and barley. About 20 tons of dung and 2 to 3 cwt. of chemical manures are used per acre. These last, which consist of superphosphate, nitrate of soda, sulphate of ammonia, and sulphate of potash, are distributed broadcast, mostly by hand. Herr Kuffner prefers applying the artificials by hand, because he objects to the ground being trodden by horses after ploughing. Others prefer distributing manures by machines on account of the greater evenness and regularity of the work, even in windy weather.

#### RIPENING OF ROOTS.

Beet roots generally get ripe in about five months. When sown in the middle of April they will thus be ripe in an average season about the middle of September. Much depends, however, on the season and the character of the land in bringing the crop to maturity. The best time for taking it up is when the roots are nearly ripe. This stage of development is recognised by most of the leaves turning yellow and flabby. As the roots ripen, the summer leaves, which are very large and have long stout stalks, dry up and fall away, and leaves are developed which are smaller and have short stalks. When these leaves are laid flat and turn yellow, the root is ripe.

Should the weather be cold and no rain fall in autumn, the crop may be left in the ground without injury a week or fort-

<sup>1</sup> In German, "*Saturations-Schlamm*." This is the precipitate of the three clarifications of the beet root juice, twice with carbonic acid and lime, and once with sulphuric acid and lime. These precipitates contain a great many organic impurities (nitrogenous matter), as well as the potash and other inorganic salts

night after the roots are quite ripe. But should the autumn be warm and wet, growth starts again, and larger leaves are thrown out. This should be avoided by all means, inasmuch as the leaves in that case are produced in a great measure at the expense of stored-up sugar in the roots. Nothing does so much injury to beet as a second growth of tops after the roots have become ripe, and hence the safest plan is to take them up as soon as possible after the crop has arrived at maturity.

A good indication of maturity is afforded when a root is cut in two with a knife. If the newly cut surfaces of the beet rapidly turn colour on exposure to the air, the ripening process is not completed; but if they remain unchanged, or turn only slightly reddish, it may be taken for granted that the beets are sufficiently ripe to be taken up. Immature roots sliced with a knife rapidly turn first red, then brownish, and finally quite dark on the surface touched by the knife.

#### THE HARVEST.

The time of harvesting is not always coincident with the time of ripening (*i.e.* when the leaves have become yellow and faded), since a large quantity of the roots must be pulled before they are fully ripe, in order to provide the necessary raw material to the sugar factories, which generally begin their work in September; moreover, the grower has to be careful that the roots are not overtaken while in the ground by severe frosts. In such cases the harvest begins with the ripest plants. The process of lifting out of the ground can be accomplished by means of the spade, but a very popular implement is a fork (*Rüben-Heber*) with a shoulder above the bifurcation to press the foot upon. The labourer loosens the earth round the beet with this fork, and with his left hand pulls up the root by the tops, shaking off as much earth as possible before placing the beet on the ground. It is very important not to damage the roots by pricking or bruising, or they will be more liable to decay when stored.

Labour being cheap, most of the work is done by hand; but the beets are also ploughed out by a variety of implements not unlike our potato-diggers in England. One such machine of Moravian construction is figured in the margin (Fig. 7.)

The crop should be harvested in fine dry weather and when



FIG. 7.—Moravian beet-lifter.

the ground is in the driest condition. If the ground be wet at the time of pulling, the earth will adhere to the root, and this will also produce a tendency to decay. Moreover, trouble will arise in the determination of the ton in the delivery of the crop to the manufacturer. In most cases the leaves are removed from the roots in the field, either at the time of lifting or at the time of loading the carts or waggons in which they are to be transported, either directly or to storage. The top of the beet, called the neck, is cut off with the leaves from the root so as to remove, with the top, that portion of the beet to which the stalks of the leaves have been attached. Very often the necks are cut off with the spade, as the roots lie in rows on the ground. The work is not done so neatly as with a knife or sickle, but a great deal faster. The object of removing this portion of the beet is to prevent the mineral salts, which have accumulated in large quantities therein, from entering the factory, as these mineral salts exercise a very deleterious influence on the crystallisation of the sugar.

If there be danger from frost the roots are piled in pyramidal heaps, either before or after the removal of the leaves, in such a manner that they may be covered by their leaves or by straw. The leaves are removed by a knife, sickle, or other instrument, sufficiently strong and heavy that the operation may be effected at a single stroke. It is estimated that in all twenty labourers are necessary to pull and prepare for transportation from the field the crop of one acre in a day.

Great care is needed in harvesting the crop, for the slightest injury to the roots is followed by a proportionate loss of sugar. When injured by careless manipulation in trimming or otherwise, fermentation is rapidly set up in the injured roots, the crystallisable sugar is converted into fruit-sugar or glucose, which does not crystallise, and is consequently lost.

The leaves and tops, which cannot be used as food for animals in their fresh state, are sometimes siloed (*eingesüuert*) for that purpose. They are thrown into holes made in the field and trodden in, being heaped up high enough to form a roof about a foot above the surface. In sandy soil they can be made sour at once, but in stiffer soils they are best laid aside and allowed to fade a little, and lose some of their water by evaporation. The covering of earth must be sufficiently thick to prevent the penetration of rain and air. Beet leaves, soured in this way, last for two years; and mixed with chaff and hay they are given to cattle and sheep. They are not, however, regarded as good food; and are often left on the field and ploughed in.

## STORAGE OF ROOTS.

When beets are to be preserved for manufacture during the winter months, or for the production of seed, special precautions have to be taken to preserve them from wet and frost. It is desirable that they should be left on the ground for a short time before they are clamped, in order that they may lose as much of their moisture as possible. The roots, however, should not be left long exposed to the air, and never to the sun. It is well, therefore, to cover temporarily the roots with their tops, in the field, before clamping. In storing, special care should be taken to prevent germination and throwing out fresh tops. As light, heat, and moisture greatly favour germination, which is necessarily attended with loss of sugar, the roots should be specially guarded against these injurious influences.

The most effectual plan to preserve the roots in good condition is to select a dry and suitable locality, to pile the roots in pyramidal clamps, about six feet broad at their base, and seven feet high, and to cover the clamps immediately with dry earth. At first the roots should be covered but slightly, in order that the moisture may readily evaporate, and subsequently, when frost sets in, another layer of earth, not exceeding one foot in thickness, may be placed on the clamps. If at once a thick layer of earth is placed upon the roots, the moisture which they throw off cannot freely escape, and in consequence they are apt to heat and to suffer changes which diminish the amount of crystallisable sugar which they contain.

The best temperature for preserving the roots in the fresh state is from 35° to 40° Fahr., and the roots should be so arranged in storage that they are not more than three feet from an air-passage,<sup>1</sup> in order to secure constant and regular renewal of the air to carry off noxious gases and superfluous moisture, and to regulate the temperature—which has always a tendency to rise. The trenches must also be thoroughly drained, so that any water that may collect in the bottom may run off.

## MANUFACTURE OF SUGAR.

The concern of the agriculturist proper in the manufacture of sugar from beet is limited to the beginning, viz., the growth of the root itself, and to the end, viz., the feeding of live stock with the residual pulp. The actual process of the making of

---

<sup>1</sup> Most factories use these air-passages, but Herr Skutezky tells me he prefers to do without them: and certainly at Wischau his beets are very well preserved,

the sugar is of secondary interest only, from the point of view of the readers of this Journal, and must be dismissed therefore in a few words. The machinery for sugar manufacture is somewhat complicated, and appears to become more so year by year: for at the Agricultural Exhibition held in the Prater at Vienna last autumn, there were quite a number of novelties for the improvement of different branches of the process claiming attention in the very interesting pavilion erected by the Central Society for the Beet-sugar Industry in the Austro-Hungarian Monarchy.<sup>1</sup>

The system of manufacture has been greatly changed since the invention by Julius Robert, of Seelowitz, of the diffusion process, and, as at present conducted, is best described in the words used by Mr. H. W. Wiley, Chemist to the United States Department of Agriculture, in a very valuable Memorandum on the Culture of the Sugar-Beet (Farmer's Bulletin, No. 3), recently published by his Department.<sup>2</sup>

The beets are first conveyed to washing-tanks provided with suitable apparatus for keeping them in motion and transferring them toward the end from which the fresh water enters, in order that the whole of the adhering soil, together with any sand and pebbles, may be completely removed. By a suitable elevator the beets are next taken to a point above the centre of the battery, whence they are dropped into a slicing apparatus by which they are sliced into thin pieces of greater or less length, so that when placed in the cells of the battery they will not lie so closely together as to prevent the circulation of the diffusion juices. The slices next pass into the diffusion battery in which the sugar is extracted. The extracted slices are carried through a press by which a portion of the water is removed, and they are then in suitable condition for use as cattle food.

The diffusion juices are carried to carbonatation or saturation tanks, where they are treated with from 2 to 3 per cent. of their weight of lime and afterward with carbonic acid until nearly all of the lime is precipitated. The slightly alkaline juices are next passed through filter presses by which the precipitated lime and other matter are removed. The juices pass next to a second set of carbonatation tanks, in which they undergo a treatment in each particular similar to the one just mentioned, except that the quantity of lime added to the second saturation is very small as compared with that of the first.

The refiltered juices from the second saturation are carried to the multiple-effect vacuum-pan and reduced to the condition of syrup. The syrups are taken into the vacuum strike pan and reduced to sugar, containing from 6 to 10 per cent. of water. The uncrystallised syrups, together with the water, are separated from the sugar by the centrifugals, and form the molasses. The molasses is either reboiled and a second crop of crystals

<sup>1</sup> For a description of the exhibits in this pavilion, see "*Oesterreichisch-Ungarische Zeitschrift für Zucker-Industrie und Lan wirthschaft*," Jahrgang xix. Heft iv. (1890).

<sup>2</sup> The publications of the Washington Department of Agriculture compel admiration for their succinctness and practical character. I have found Mr. Wiley's paper invaluable in the preparation of this sketch, and have not hesitated to quote freely from it.

obtained, or is treated in various ways for separating the sugar which it still contains.

If refined sugar is to be made, the juices and syrups are passed over bone-black to decolourise them, and the crystals are washed in the centrifugal in order to make them perfectly white. Another method consists in treating the juice with sulphurous acid and purifying the crystals by washing them with syrups of varying degrees of consistency until all the molasses adhering thereto are washed away.

#### FEEDING OF STOCK WITH REFUSE PULP.

The waste products from the sugar factories consist of molasses and the refuse pulp. The molasses are used for various purposes, and their utilisation in distilleries is largely on the increase. The pulp makes a most excellent cattle food, its value being fully 20 per cent. that of the beet, and being often assessed at a higher figure. It is much esteemed for its fattening qualities, and it is regarded by some as equal if not superior in nutritive properties to the roots from which it is obtained.

The pulp may be fed either in the fresh state or preserved in silos. Extensive experiments have recently been successfully made in drying the pulp and preserving it in the dry state; but this method is not yet generally adopted.

It has, when fresh, a rather insipid or but slightly sweet taste, and rapidly turns faintly acid on keeping. It is given to fattening beasts mixed with straw, chaff, meal, and similar materials, as by itself it is rather deficient in flesh-forming compounds. Kept for any length of time, it turns decidedly acid, and on some of the farms that I visited, there was a very pungent odour in the mixing room. It is, however, quite as much relished in this state by cattle and sheep as when fresh, probably because the lactic acid, which is generated during the time of keeping, makes it more digestible. Except in its more acid taste, old pulp differs but slightly in its appearance and general character from new.

I saw at both the factories I visited a great number of very fine animals in process of fattening, though their pedigree seemed to be of a nondescript order. Herr Kuffner of Lundenburg has quite a reputation for his cattle, and at the show of butcher's beasts held at Vienna during last year's exhibition, a Diploma of Honour was unanimously awarded to him by the jury for his excellent collection of fat cattle. At Lundenburg about 2,000 beasts are fattened every year. Some of them consist of beasts who have done their share of work in the fields; but the majority are animals bought directly at cattle

markets in order to be fattened immediately. Herr Kuffner buys only young and well-developed beasts of the variety known as the German race, and of about 70 stones live weight. The fattening process usually lasts from 140 to 155 days. Each beast in good condition receives per day, 112 lb. of beet-pulp from the factory, 7 lb. of hay, and 7 lb. of chopped straw; 2 lb. of groats after the fourth week, increasing gradually to 4 lb. in the twelfth week, and to 7 lb. in the last week; 1 lb. of oil-cake after the second week, increasing in the seventh week to 2 lb., and in the ninth week to 3 lb.; 1 lb. of straw, and a pinch of salt. The destination of the beasts was not stated, but they probably go to Vienna, which is only three hours off.

At Wischau about 1,000 beasts are fatted annually, chiefly for consumption at Brunn, the capital of Moravia, and a large fine city of 95,000 inhabitants, chiefly occupied in the cloth and machinery trade. The beasts at Wischau are mostly of the Styrian and Moravian breeds. Only young heavy beasts are bought in, of at least 84 stones live weight. The fattening usually lasts 150 days.

#### LABOUR.

Labour is not expensive in the beet-growing districts. For the harvest season, a large number of workmen from distant localities are employed, the wages of day labourers being 9*d.* to 1*s.* a day for men and 8*d.* to 10*d.* a day for women. These wages are often doubled when piece-work is in force, as it is for most of the operations of the farm. The system of administration of the farms was found almost universally to be very elaborate and exact: so that any statistical fact desired, as to labourers employed, wages, yields, or live stock, was at once forthcoming without delay or difficulty.

I had the curiosity to inquire somewhat closely into the farm staff at Wischau, and I found they numbered altogether 371, divided as follows: 30 salaried officers engaged in various capacities, 8 shepherds, 24 foremen, 29 stablemen, 163 herdsmen, 22 dairymaids, and 125 labourers. All these received their wages in cash, with the exception of a very few who also had allowances in kind.

The number of extra hands employed during the season of cultivating and harvesting the roots is often from two to three thousand. The work of cultivation is paid for by the day, as it is considered that it is done better under this system than by piece-work. The average wages of day labourers are 8*d.* per



day, decreased to  $6\frac{1}{2}d.$  in the short days of winter, but increased to  $10d.$  or  $1s.$  in times of pressure.

Harvesting and threshing are, on the contrary, always done by piece-work, a special employé being set apart to make these payments. The price paid for pulling beet is from  $8s. 4d.$  to  $16s. 8d.$  per acre.

On most farms the greater proportion of the agricultural operations in which animals are required are performed by oxen; but horses are coming more into favour for certain purposes, and, at both Lundenburg and Wischau, I found good teams of horses, though much lighter in character than those to which we are accustomed in England.

At Lundenburg there are 170 horses, and about 350 draught-oxen in the busy time; and at Wischau there were 79 horses and 450 oxen for work on the farms, besides 641 fattening beasts, 223 dairy cows, 23 young oxen, 12 bulls, 6 calves, and 101 sheep. The horses are of no particular breed, being either purchased in the country or brought from Hungary. The working oxen were at Wischau exclusively of the Hungarian breed, which is famous for draught purposes and is very hardy.

At Lundenburg horses receive per day 11 to 13 lb. of oats or crushed maize, and 15 lb. of hay; draught-oxen, 112 lb. of beet-pulp, 11 lb. of meadow hay, 4 lb. of chopped straw, and 3 lb. of groats, besides 14 oz. of salt per day. The rations at Wischau were much the same, except that there was less pulp, and less hay; but more straw and 3 lb. of oilcake for the oxen.

#### GENERAL REMARKS.

As to the profitableness of beet cultivation from a purely agricultural point of view, it is not possible to give any very precise information, since the money results of growing the root depend almost wholly upon the price obtained for the manufactured article—sugar. Dr. G. Shack-Sommer, of Liverpool, who has recently made a praiseworthy attempt to direct attention in this country to the subject of beet-growing, says<sup>1</sup> that “from the very best authorities on the Continent he has gathered the information that the immediate result of opening a beet-root factory in convenient proximity to the growers is to increase the value of land by one-third.” However this may be, it is undeniable that the intensive cultivation of the soil which

---

<sup>1</sup> *Journal of the Society of Chemical Industry*, April 30, 1891.

the beet requires, and without which the growing of it should not be attempted, improves the land, and enables it, directly or indirectly, to give busy and remunerative employment to a considerable quantity of labour.

Sugar is now low in price, and the Austrian manufacturers are, like their fellows elsewhere, eloquent as to the meagreness of their profits. Those of them who have made contracts for a term of years with farmers to supply roots, at rates which now appear to them high, demand a revision of prices, and talk of limiting the production. There is an agitation in Austria, as in England, about the lowering of railway rates, and the Government is chided for not taking steps for the "development of exports."

These are all matters into which it would be impossible for me to dwell here at any length. The fact remains that for some parts at least of Austria the cultivation of the sugar-beet has been the mainspring and the mainstay of all agricultural improvement; and to it is due most of the activity, the progress, and the prosperity of the districts which I visited.

ERNEST CLARKE.

---

# Official Reports.

## REPORT OF THE COUNCIL

*To the Anniversary General Meeting of Governors and Members, held in the Hall of the Royal Medical and Chirurgical Society, at 20 Hanover Square, W., on Friday, May 22, 1891.*

THE Council have to report the following changes in the List of Governors and Members during the year which has elapsed since the last Anniversary Meeting in May 1890 :—5 new Governors and 648 Members have joined the Society, 7 have been reinstated under Bye-Law 12, and 4 Members have qualified as Governors ; whilst the deaths of 3 Annual Governors, 7 Life Governors, 1 Honorary Member, 137 Life Members, and 145 Annual Members have been reported. A total of 34 Members have been struck off the books under Bye-Law 10, owing to absence of addresses ; 150 under Bye-Law 11, for arrears of subscriptions ; and 223 have resigned.

2. Amongst other Governors and Members whose loss by death the Society has had to deplore since the beginning of the present year are the Duke of Bedford, K.G., and the Earl of Powis (Trustees of the Society), the Duke of Somerset, Earl Beauchamp, Earl Granville, K.G., Lord Edward Cavendish, M.P., Lord Heytesbury (a Member since 1843), the Rt. Hon. G. A. F. Cavendish-Bentinck, M.P., Sir Richard Sutton, Bart., Sir Matthew Wilson, Bart. (a Member since 1840), Mr. Thomas C. Baring, M.P., Mr. Henry A. Brassey, Col. Hambro, M.P., Col. P. S. Humberston (a Member of the Council from 1858 to 1865), Mr. Edmund Beck, of Sandringham, Mr. Nathaniel Clayton, of Lincoln, and Mr. David Greig, of Leeds.

3. These and other changes bring the total number of Governors and Members now on the Register to 10,928, divided as follows :

- 34 Foundation Life Governors (Members elected before the granting of the Charter on March 26, 1840) ;
- 60 Governors paying an annual subscription of 5*l.* ;
- 83 Life Governors who have compounded for their annual subscriptions ;
- 19 Honorary Members ;

196	(brought forward)
6,921	Members paying an annual subscription of 1 <i>l.</i> ;
16	Members who, having paid annual subscriptions for 50 Years, have become Life Members ;
3,731	Life Members who have compounded for their annual subscriptions ;
64	Life Members by Examination ;
<hr/>	
10,928	Total number of Governors and Members ;
or a net decrease of 56 Members during the year.	

4. Since the last Meeting the Society has sustained a very severe loss by the death of the Duke of Bedford, a Trustee of the Society, and one of its most munificent benefactors. His Grace not only provided the land for the establishment of the Society's Experimental Farm at Woburn in the year 1876, but most generously bore the whole cost of the valuable experiments carried on there since that time. The Duke acted as Chairman of the Education Committee of the Society from 1874 to 1879, when he succeeded H.R.H. the Prince of Wales as President of the Society after the Kilburn Meeting. Though not often present of late years at the meetings of the Council, His Grace continued to the last to take an active interest in the Society's welfare. The Council have great gratification in reporting that the present Duke of Bedford, on succeeding to the title, spontaneously expressed his wish to provide for the carrying on of the experiments at Woburn as heretofore, thereby ensuring the continuance of a work not only valuable in itself, but of the highest importance to agriculture and to the country at large.

5. The Council have also to regret the loss by death of the Earl of Powis, another of the Trustees of the Society. The late Earl joined the Council as long ago as 1856, and had ever since taken an active interest in the general business of the Society. Lord Powis was President in the year 1860-61, on the occasion of the very successful Meeting held at Leeds, and was elected a Trustee of the Society soon after the termination of his presidency.

6. The vacancy caused by the death of the Duke of Bedford has been filled by the transference of the Earl of Ravensworth to the list of Trustees ; and to fill other vacancies Mr. E. Wilfrid Stanyforth, of Kirk Hammerton Hall, York, and Lt.-Col. J. E. Curtis-Hayward, of Quedgeley, Gloucester, have been elected Members of the Council.

7. The accounts for the year 1890 have been examined and certified by the Auditors and Accountants of the Society, and are published in the current number of the Journal. The final results of the working of the year are that, after writing off the customary percentages for depreciation, the Society's assets amounted at December 31, 1890, to 35,176*l.* 13*s.* 2*d.*, as against 38,056*l.* 7*s.* 10*d.* at the end of 1889.

8. The Council have made further contributions amounting to 200*l.*, to the funds of the Mansion House United Association on Railway Rates, making in all 300*l.* subscribed by the Society towards safeguarding the interests of agriculturists in the Parliamentary inquiry now proceeding; and they have also granted, out of the annual fund at the disposal of the Veterinary Committee, a sum of 50*l.* towards the expenses of the International Congress of Hygiene which is to be held in London next August, and which will have a section specially devoted to the consideration of the relations of the diseases of animals to those of man.

9. The Society's forthcoming Country Meeting at Doncaster promises to prove of great interest and exceptional magnitude. The total amount of space allotted in the Implement Department is 12,743 feet run, exclusive of open ground space, as compared with 9,078 feet at Plymouth last year, 15,602 feet at Windsor in 1889, 10,743 feet at Nottingham in 1888, and 8,217 feet at Newcastle in 1887. With the exception of the Exhibition at Windsor, the entry of Implements is, in fact, larger than any since the year 1884, when 12,904 feet were allotted at the Shrewsbury Meeting. The total entries of Live Stock (horses, cattle, sheep, and pigs) are 2,240, as compared with 1,769 at Plymouth, 4,014 at Windsor, 1,875 at Nottingham, and 1,833 at Newcastle. The entries of Live Stock are thus nearly 400 in excess of any previous ordinary Meeting of the Society, notwithstanding the operation of the new rule limiting to three the number of entries in the same class that can be made by any Exhibitor. There are 717 entries of horses, 669 of cattle, 649 of sheep, and 205 of pigs, besides 803 of poultry, 55 of cheese, and 189 of butter.

10. The general arrangements for the Meeting are well advanced. The Implement Yard and the Dairy will be open to Members of the Society and the public on Saturday, June 20, when the charge for admission to non-members will be 2*s.* 6*d.* The judging will take place in all the classes on Monday, June 22, when the charge for admission will be 5*s.* On Tuesday and Wednesday the charge for admission will be 2*s.* 6*d.* each day; and on the last two days, Thursday and Friday, it will be 1*s.* each day.

11. Twenty-nine candidates have entered for the competitions of Buttermakers for the Society's Prizes and Certificates, to take place in the Showyard, from Tuesday, the 23rd, to Thursday, the 25th June. Twenty-six shoeing-smiths practising in the Society's District E (*i.e.* the county of York) will compete for the Prizes offered for shoeing Hunters and Agricultural Horses on the Tuesday, Wednesday and Thursday of the Meeting. Arrangements are in progress for the delivery by experts of lectures on Dairy matters and on Horse-Shoeing in the course of the week.

12. At the Show of Horses which was held at the Royal Agricultural Hall last March, under the auspices of the Royal Commis-

sion on Horse Breeding, of the Hunters' Improvement and Hackney Horse Societies, and of this Society, and which was honoured by the presence of Her Majesty the Queen, their Royal Highnesses the Prince and Princess of Wales, and other members of the Royal family, the three Premiums offered by the Society for Thoroughbred Stallions serving mares in District E during the present season were awarded to Mr. David Cooper's *Linnæus*, Mr. E. Hodge Banks's *Moss Hawk*, and Mr. Thomas Carr's *Crom-A-Boo*.

These stallions, which will be exhibited at the Doncaster Meeting from the morning of Monday, June 22, to the evening of Wednesday, June 24, are located for the season as follows:—*Linnæus* at his owner's stables, Bainesse, Catterick, travelling also to Bedale, Northallerton, Scotch Corner and Richmond; *Moss Hawk*, Driffield and travelling the district; and *Crom-A-Boo*, Ripon and travelling the district.

13. As already reported, invitations for the holding of the Society's Country Meeting of 1892 in their respective localities were received from the city and county of Gloucester and the town and county of Warwick; and on the 4th February last deputations from both districts waited upon the Council in support of these invitations. After duly weighing the merits of the sites and other accommodation offered by both Gloucester and Warwick, the Council decided to accept the invitation of the latter; and the Country Meeting of 1892 will therefore be held at Warwick, in the grounds of the Castle Park. The historic interest of this site, its beautiful situation, and the proximity of Birmingham and other large centres of population in the Midlands, lead the Council to anticipate at the Warwick Meeting a highly successful gathering.

14. The Council have already decided to hold, in connection with the Warwick Meeting, trials of Ploughs in competition for prizes in eight classes, as follows:

Class	First Prize.	Second Prize.
1. For the best single-furrow plough for light land . . . . .	£10	£5
2. For the best single-furrow plough for strong land . . . . .	£10	£5
3. For the single-furrow plough best adapted for a press-drill and broad-cast sowing . . . . .	£10	£5
4. For the best two-furrow plough . . . . .	£10	£5
5. For the best three-furrow plough . . . . .	£10	£5
6. For the best digging plough for light land . . . . .	£10	£5
7. For the best digging plough for heavy land . . . . .	£10	£5
8. For the best one-way plough . . . . .	£10	£5

These trials will take place early in the spring of 1892, on land selected by the Society, in the neighbourhood of Warwick; and the competing ploughs will, after the trials, be retained in the possession of the Society until the Warwick Meeting, when they will all be exhibited together in the Showyard in a space set apart for the purpose. Entries for the prizes must be made on or before Saturday, July 25, 1891.

15. In accordance with the usual rotation of Districts, the Country Meeting of 1893 will be held in District G, which consists of the counties of Chester and Lancaster and of North Wales.

16. The Council have appointed Mr. Lewis P. Rees, of 5 Lammas Street, Carmarthen, a Provincial Veterinary Surgeon of the Society. The Examiners on the diseases of animals of the farm other than the horse, in the examinations for the diploma of the Royal College of Veterinary Surgeons held last year, have reported that the following gentlemen attained the greatest distinction :—

Mr. J. E. Row, Veterinary Infirmary, Newgate Street, Chester.

Mr. F. E. PLACE, 4 Parker's Place, Exmouth.

The Society's Silver Medal has, therefore, been awarded to Mr. Row, and the Bronze Medal to Mr. Place.

17. In the Department of Comparative Pathology at the Royal Veterinary College, which is assisted by a grant from the Society, important investigations relative to the diseases of farm stock have been carried on. Foot-rot among sheep has been for some time a subject of inquiry, and experiments have been made with a view of determining to what extent the disease is contagious. At present, a number of sheep are pastured on a clay subsoil, diseased and healthy animals being penned together ; while, as a control experiment, some sheep which have not been exposed to contact with foot-rot are penned on another part of the meadow. Experiments have also been conducted to test the communicability of tubercle to susceptible animals by feeding on meat from tuberculous cattle, such meat being, so far as could be ascertained, free from tubercle bacilli. These experiments have been attended with positive results in a large proportion of the animals which were fed. Directions have also been given for an inquiry into the causation of abortion in cattle.

18. Pink-eye among horses has lately attracted a great deal of attention, and the question of including the disease under the provisions of the Contagious Diseases (Animals) Acts has been much debated. At one time there was a strong feeling in favour of this action being taken. But the view seems to have undergone considerable modification when it was realised that any interference with the free movement and use of horses over a large extent of country would cause serious interruption to trade. Pink-eye is a form of influenza which is not fatal if the animals attacked are put under proper veterinary treatment as soon as signs of illness are apparent. The most serious losses have occurred here and in America in consequence of the practice of working horses while suffering from the disease.

19. It was reported to the Members in December, 1889, that the Society's Consulting Chemist, Dr. J. Augustus Voelcker, had been selected by the Secretary of State for India, on the recommen-

dation of Sir James Caird, to advise the Indian Government, after personal examination and inquiry, as to the best course to be adopted for the improvement of Indian agriculture by scientific means. Dr. Voelcker has now returned to his duties, and the Council report with gratification that the Government of India have cordially acknowledged the character and value of his work during his mission in that country. During Dr. Voelcker's absence his duties as Consulting Chemist were very ably and efficiently discharged by his brother, Mr. E. W. Voelcker, upon whom the Council have conferred the Life Membership of the Society in recognition of their appreciation of his services.

20. The number of samples analysed in the laboratory on behalf of Members from December to the end of April has been 727. The subject of the better regulation of the Sale of Fertilisers and Feeding Stuffs, which has been brought before Parliament, is one in which the Society is greatly interested, and it is sincerely to be hoped that such measures will be adopted as will give practical effect to the recommendations which this Society's Chemical Committee have for so long been endeavouring to impress upon the Members, but which have heretofore lacked any legal force or support.

21. Feeding experiments both on Sheep and on Bullocks have been carried out at Woburn during the winter. Those with Bullocks were in repetition of an experiment of a former year, upon the comparative values of decorticated and undecorticated cotton cake. The Field experiments are being continued as heretofore.

The Norfolk Chamber of Agriculture, the Royal Manchester, Liverpool, and North Lancashire Agricultural Society, and the Essex Agricultural Society have, as in former years, carried out the system of local experiments inaugurated in 1886.

22. It appears from the Consulting Botanist's report that the quality of the grass seeds continues this year to be satisfactory, but that the clovers have been less pure than in previous years, and have contained a larger proportion of the seeds of dodder. Investigations have been made into fungoid diseases affecting the larch and oak. The ingredients in pasture and in hay likely to prove injurious to stock have been investigated in a number of cases. Ergot was found to be frequently present, but not in quantity sufficient to be injurious.

23. The Council have, at the request of the Board of Agriculture, undertaken to organise and carry out a series of experiments in different districts of England and Wales, for the purpose of testing the efficacy of sulphate of copper as a preventive of the special fungus which attacks the potato plant. It is proposed that the selected potato-plots shall be dressed with sulphate of copper upon a uniform plan, by a person appointed by the Society; that the crops shall in the course of their growth be inspected by the Con-



sulting Botanist ; and that the produce when dug up shall be separated and weighed under the superintendence of an officer of the Society.

**24.** The work of the Consulting Entomologist is going on steadily. Information is being constantly desired regarding the habits of crop insects and the means of preventing their ravages, and to some extent also regarding timber and forest insects. Warble attack is also receiving attention. A far greater amount of interest is being taken by the public in practicable methods of lessening loss from orchard insect attacks than has ever previously been the case, and from the minute care that is being bestowed there is great hope of good results. Correspondence also frequently takes place in this department as to the best methods of promoting plain and practical instruction in Agricultural Entomology, in connection with the increased attention bestowed on Technical Agricultural Education in various parts of the country.

**25.** The question of Technical Education in Agriculture, in connection with the recent allocation to County Councils of grants under the Local Taxation (Customs and Excise) Act, 1890, has again received the serious consideration of the Education Committee. They have presented two valuable reports on the subject, which have been adopted by the Council and published in the Journal. As numerous inquiries have been addressed to the Society on behalf of County Councils by persons seeking for information, it has been deemed desirable to reprint these reports, together with an instructive article on the general question of Technical Education in Agriculture, contributed by Dr. W. Fream to the current number of the Journal, for distribution in pamphlet form to Members of the Education Committees of County Councils and to others interested in the matter. The Education Committee have also been charged by the Council with the preparation of a Text Book for the teaching of Agriculture in Elementary and Continuation schools, which it is proposed to issue at an early date under the authority of the Society.

**26.** Twenty-one candidates entered and thirteen actually competed at the Society's Senior Examinations which took place from the 12th to the 16th of this month. The answers of the candidates are now under the consideration of the Examiners, and the results will be announced at the Meeting of Council to be held in June.

By Order of the Council,

ERNEST CLARKE,

*Secretary.*

## FIELD EXPERIMENTS AT WOBURN IN 1889 AND 1890.

### A. EXPERIMENTS ON CONTINUOUS CORN GROWING.

#### I. *The continuous growth of Wheat.*<sup>1</sup>

THE years 1889 and 1890 comprised the thirteenth and fourteenth seasons of consecutive wheat crops. The variety grown was Bro-wick red wheat, 9 pecks per acre of seed being dibbled in by hand, Nov. 7-9 in 1889, and Oct. 24-26 in 1890. The same manures have, with the variations mentioned in the table of results, been used each year since 1877 on the respective plots. The mineral manures were sown on plots 4, 5, 6, 8 and 9 two or three days before the seed went in, and the nitrogenous top-dressings of ammonia-salts (sulphate of ammonia and muriate of ammonia in equal parts) and nitrate of soda were applied in spring (April 16-17) to the plots 2, 3, 5, 6, 8 and 9, due to receive them. Plots 1 and 7 have been left without manure since the commencement in 1877, while plot 4 has had only the mineral manures during the same period. On plot 11B, farmyard manure at the rate of about 7 tons per acre was applied early in February. This had been made by bullocks in the feeding-boxes in December consuming definite weights of food, so that the manure produced might yield the estimated amount of 200 lb. ammonia per acre when put on the land, and afford thus a comparison with the effect of ammonia applied in the form of nitrogenous top-dressings on plots 2, 3, 5, 6, 8, and 9. Plot 11A, which last had this same manuring with farmyard manure in 1882, has since had none, in order to see how long the effect of the application would remain. On plots 10A and 10B the same experiment had been tried, but with only a half-dressing (about 4 tons), of farmyard manure. This amount proving, however, of little efficacy, it was decided to try in place of it a material like rape-cake, which supplies organic nitrogenous matter to the crop. Accordingly, both plots 10A and 10B received on Jan. 23, 1889 a dressing of about 8 cwt. per acre of rape-cake, this yielding 50 lb. of ammonia per acre to the land. After this application in 1889 plot 10A was left in 1890 without any further dressing, but it was renewed on 10B, 100 lb. of ammonia to the acre being applied to this plot in 1890.

The rainfall for the year 1889 was 23·67 inches, almost identical with that of the very unfavourable year 1888. May was an exceptionally wet month, while both in July and August there were 11 wet days. In 1890 the rainfall was considerably less, viz. 16·8 inches, but although April and May were fine bright months, there

<sup>1</sup> These experiments are for the purpose of showing the effect of different artificial manures, and of farmyard manure, upon corn crops grown year after year on the same land.

TABLE I.—PRODUCE OF CONTINUOUS WHEAT.

PLOTS ½ acre	MANURES PER ACRE, applied every year since 1877	THIRTEENTH SEASON, 1889 FOURTEENTH SEASON, 1890.									
		PRODUCE PER ACRE					PRODUCE PER ACRE				
		Dressed Corn			Straw, Chaff, &c.	Dressed Corn			Straw, Chaff, &c.		
		Wei- ght	Num- ber of Bus- hels	Wei- ght per Bus- hel		Wei- ght	Num- ber of Bus- hels	Wei- ght per Bus- hel			
lb.	lb.	lb.	lb.	lb.	lb.	lb.	lb.	lb.	lb.		
775	13.1	59.2	14 2 2	827	14.1	58.7	14 2 22				
1	Unmanured.	775	13.1	59.2	14 2 2	827	14.1	58.7	14 2 22		
2	200 lb. ammonia-salts, contain- ing 50 lb. Ammonia	1,552	26.3	59.08	26 1 27	1,445	24.7	58.38	19 2 15		
3	275 lb. nitrate of soda, contain- ing Nitrogen=50 lb. Ammonia	1,042	18.9	55.06	23 0 2	1,727	31.2	55.29	26 3 14		
4	200 lb. sulph. potash, 100 lb. sulph. soda, 100 lb. sulph. magnesia, 3½ cwt. superphos- phate of lime	729	12.2	59.75	15 1 27	898	15.4	58.37	15 0 6		
5	200 lb. sulph. potash, 100 lb. sulph. soda, 100 lb. sulph. magnesia, 3½ cwt. superphos- phate of lime, and 200 lb. ammonia-salts, containing 50 lb. Ammonia	2,130	35.5	59.91	37 3 11	1,829	30.3	60.21	26 3 0		
6	200 lb. sulph. potash, 100 lb. sulph. soda, 100 lb. sulph. magnesia, 3½ cwt. superphos- phate of lime, and 275 lb. nitrate of soda, containing Nitro- gen=50 lb. Ammonia	1,771	30.5	58.03	36 2 1	1,967	34.1	57.62	31 1 4		
7	Unmanured.	779	13.9	55.75	14 0 4	918	15.7	58.33	14 2 24		
8A	200 lb. sulph. potash, 100 lb. sulph. soda, 100 lb. sulph. magnesia, 3½ cwt. superphos- phate of lime	—	—	—	—	1,568	26.0	60.30	23 0 18		
8B	Ditto	1,240	21.2	58.5	19 0 6	—	—	—	—		
8B	The same minerals as above, and 400 lb. ammonia-salts, con- taining 100 lb. Ammonia	—	—	—	—	2,350	39.0	60.25	31 2 2		
8A	Ditto	2,578	44.4	58.0	45 1 6	—	—	—	—		
9A	200 lb. sulph. potash, 100 lb. sulph. soda, 100 lb. sulph. magne- sia, 3½ cwt. superphosphate of lime	—	—	—	—	1,008	18.2	58.62	17 2 22		
9B	Ditto	642	11.4	56.25	11 3 14	—	—	—	—		
9B	The same minerals as above, and 550 lb. nitrate of soda, con- taining Nitrogen=100 lb. Ammonia	—	—	—	—	2,358	42.3	55.75	38 0 12		
9A	Ditto	1,814	32.8	55.23	42 3 8	—	—	—	—		
10A	1882-8. No Manure (having re- ceived about 4 tons Farmyard Manure, giving 100 lb. Am- monia, each year 1877-81)	1,158	19.8	58.4	20 2 6	1,050	17.6	59.62	15 2 16		
10A	1889. Rape-cake about 8 cwt., containing Nitrogen=50 lb. Ammonia.	—	—	—	—	—	—	—	—		
10A	1890. No Manure	—	—	—	—	—	—	—	—		
10B	1877-88. Farmyard Manure about 4 tons, giving 100 lb. Ammonia, each year	—	—	—	—	—	—	—	—		
10B	1888. No Manure	—	—	—	—	—	—	—	—		
10B	1889. Rape-cake about 8 cwt. containing Nitrogen=50 lb. Ammonia.	1,416	23.8	59.4	25 0 10	1,830	30.4	60.17	28 1 26		
10B	1890. Rape-cake, about 16 cwt. containing Nitrogen=100 lb. Ammonia	—	—	—	—	—	—	—	—		
11A	No Manure (having received manure as 11B in each of the five seasons previous to 1882, but none in 1882 or since).	922	15.8	58.23	15 2 0	1,178	19.7	59.62	18 1 14		
11B	Farmyard Manure, estimated to contain Nitrogen=200 lb. Ammonia. Weight about 7 tons.	1,796	30.5	58.9	27 2 16	1,736	29.5	58.75	31 1 22		

were many wet days in June, July, and August. Under these circumstances the crop of 1889 was very thin and but little superior to that of 1888, nor did that of 1890 show any large increase. The crops were cut and harvested Aug. 17-29 in each year. The results are given in Table I., page 363.

The yields of the duplicate unmanured plots agree very closely in 1889; in 1890 plot 7 is rather the higher. Minerals alone have as usual given no increase. In 1889 ammonia salts, whether used alone or with mineral manures, produced a larger crop than nitrate of soda, but in the drier year, 1890, the exact reverse was the case, nitrate of soda in each instance then showing the higher return. The appearance of the plots on which these nitrogenous top-dressings are used is, in the earlier stages, very poor and the plant is very uneven, nevertheless towards harvest they seem to pull up wonderfully, and the yield is much more than it has seemed likely to be. The small increase (two bushels) from putting on in 1889 the double dressing of nitrate of soda is very noticeable, and while the omission of ammonia-salts for a single year reduces the corn to 21 bushels, the effect of leaving out nitrate of soda is to take it as low as 11.4 bushels, which is even below the unmanured yield. This greater diminution in the case of nitrate of soda is also very marked in 1890. The effect of rape cake, applied so as to give 100 lb. of ammonia per acre, is greater than that of farmyard manure estimated to contain double that amount. Plot 11A still seems to show the presence of some unexhausted fertility from the farmyard manure put on in former years.

## II. *The continuous growth of Barley.*

THE duration of these experiments is the same as those on wheat growing, so that the results now to be recorded are those of the thirteenth and fourteenth years of consecutive barley crops. The plan of manuring is the same as with the wheat. Golden Melon barley at the rate of nine pecks per acre was drilled in 1889 on March 13th, and in 1890 on April 3rd; the mineral manures were applied the day previously and the farmyard manure for plot 11B, which had been made during December, was put on as a top-dressing just after sowing was finished. Rape-cake was given to plot 10 a few days later, and the nitrogenous top-dressings were made on April 29 in 1889 and May 9 in 1890. 1889 was a most unfavourable year for barley, and heavy storms occurring in July knocked down the crop very much, especially on the highly manured plots. 1890 was a more favourable season for barley, and an average yield was obtained.

Cutting and harvesting of the crop took place August 13-29 in year. The results are given in Table II. opposite.

Mineral manures produced no increase in 1889, and only about three bushels in 1890. The results from the use of nitrate of soda or from ammonia-salts when used alone were closely alike both years, but used in combination with minerals, nitrate of soda gave

TABLE II.—PRODUCE OF CONTINUOUS BARLEY.

PLOTS, ½ acre	MANURES PER ACRE, applied every year since 1877	THIRTEENTH SEASON, 1889						FOURTEENTH SEASON, 1890			
		PRODUCE PER ACRE						PRODUCE PER ACRE			
		Dressed Corn			Straw, Chaff, &c.	Dressed Corn			Straw, Chaff, &c.		
		Weight	Number of Bushels	Weight per Bushel		Weight	Number of Bushels	Weight per Bushel			
	lb.		lb.	cwt. qr. lb.	lb.		lb.	cwt. qr. lb.			
1	Unmanured . . . . .	573	10·8	53·0	6 1 4	1,558	29·5	52·82	14 2 2		
2	200 lb. ammonia-salts, contain- ing 50 lb. Ammonia . . . . .	1,515	28·0	54·04	13 1 6	2,126	39·6	53·61	19 1 18		
3	275 lb. nitrate of soda, contain- ing Nitrogen=50 lb. Am- monia . . . . .	1,425	27·6	51·62	15 0 27	2,029	39·2	51·75	21 0 7		
4	200 lb. sulphate of potash, 100 lb. sulphate of soda, 100 lb. sul- phate of magnesia, 3½ cwt. superphosphate of lime . . . . .	687	13·0	52·75	5 2 25	1,736	32·2	53·96	13 3 11		
5	200 lb. sulph. potash, 100 lb. sulph. soda, 100 lb. sulph. magnesia, 3½ cwt. superphos- phate of lime, and 200 lb. am- monia-salts, containing 50 lb. Ammonia . . . . .	1,778	32·3	54·94	14 1 11	2,697	49·2	54·81	22 3 2		
6	200 lb. sulph. potash, 100 lb. sulph. soda, 100 lb. sulph. magnesia, 3½ cwt. superphos- phate of lime, and 275 lb. nitrate of soda, containing Nitrogen=50 lb. Ammonia . . . . .	1,794	34·6	51·9	21 1 20	2,800	52·1	53·71	26 0 17		
7	Unmanured . . . . .	667	13·1	50·83	6 2 3	1,292	24·6	52·54	12 0 6		
8A	200 lb. sulph. of potash, 100 lb. sulph. of soda, 100 lb. sulph. of magnesia, 3½ cwt. super- phosphate of lime . . . . .	—	—	—	—	1,856	34·6	53·62	17 3 20		
8B	Ditto . . . . .	1,194	21·9	54·5	9 1 2	—	—	—	—		
8B	The same minerals as in 8B, and 400 lb. ammonia-salts, con- taining 100 lb. Ammonia . . . . .	—	—	—	—	2,814	51·9	54·17	28 2 4		
8A	Ditto . . . . .	2,172	41·7	52·0	29 0 12	—	—	—	—		
9A	200 lb. sulph. of potash, 100 lb. sulph. of soda, 100 lb. sulph. of magnesia, 3½ cwt. super- phosphate of lime . . . . .	—	—	—	—	2,274	42·2	53·90	21 1 4		
9B	Ditto . . . . .	958	18·1	53·0	8 3 20	—	—	—	—		
9B	The same minerals as in 9B, and 550 lb. nitrate of soda, con- taining Nitrogen=100 lb. Am- monia . . . . .	—	—	—	—	2,780	54·0	51·41	31 1 22		
9A	Ditto . . . . .	1,986	39·1	50·75	33 1 14	—	—	—	—		
10A	1882-8. No Manure (having received about 4 tons Far- yard Manure, giving 100 lb. Ammonia, each year 1877-81) 1889. Rape-cake, about 8 cwt., containing Nitrogen=50 lb. Ammonia . . . . .	1,120	21·4	52·25	12 3 4	1,634	31·1	52·50	14 3 14		
10B	1890. No Manure . . . . . 1877-87. Farmyard Manure, about 4 tons, giving 100 lb. Ammonia, each year . . . . . 1888. No Manure . . . . . 1889. Rape-cake, about 8 cwt., containing Nitrogen=50 lb. Ammonia . . . . . 1890. Rape-cake, about 16 cwt., containing Nitrogen=100 lb. Ammonia . . . . .	998	18·8	53·12	10 2 22	2,032	39·1	51·94	22 1 8		
11A	No Manure (having received manure as 11B in each of the five seasons 1877-81, but none in 1882 or since) <sup>1</sup> . . . . .	1,274	24·1	52·75	12 3 12	1,952	36·9	52·87	19 0 12		
11B	Farmyard Manure, estimated to contain Nitrogen=200 lb. Am- monia. Weight about 7 tons <sup>2</sup> . . . . .	1,462	27·2	53·66	13 1 12	2,774	51·8	53·50	26 2 18		

<sup>1</sup> In 1888 farmyard manure as in 11B was applied in error

<sup>2</sup> Omitted in 1888 in error.

about two bushels increase and considerably more straw. Doubling the dressing of nitrate of soda gave only 4 bushels more in 1889, and 2 bushels extra in 1890. Rather more relative increase was obtained from doubling the ammonia-salts, but nitrate of soda gave the higher total yields. The omission of the top-dressing for a single year did not in either season give such marked distinctions as heretofore, between ammonia-salts and nitrate of soda, when severally omitted. Thus in 1889 when ammonia-salts were left out the yield fell to 21.9 bushels and to 18 bushels when nitrate of soda was not put on; but in 1890 the crop grown on the residue of the nitrate of the former year was even higher than that from the ammonia-salts. It is only fair, however, to mention that in this year plot 8A was very patchy indeed. Plot 2 as usual looked at first extremely bare in parts. In 1889 neither farmyard manure nor rape cake applied as top-dressings told well, and in 1890 the effect of the rape cake was not nearly so marked—when compared with the farmyard manure—as in the case of the wheat crop.

#### B. THE ROTATION EXPERIMENTS.

These experiments were designed to ascertain, in brief, whether the difference between the high manurial value of decorticated cotton-cake when consumed on the land, as compared with the lower one of maize-meal, is brought out in the respective crops grown by the use of each, and also if the same difference is shown when artificial manures of estimated equivalent strength to decorticated cotton-cake and maize-meal severally are used.

The original plan of experiment was to manure for the root-crop with dung made by the consumption of decorticated cotton-cake and maize-meal respectively, then to feed off the roots on the land, following with barley, and after that clover, which latter was eaten off with decorticated cotton-cake and maize-meal once more, in preparation for the wheat crop. After following this plan for two entire four-course rotations, viz. 1877-84, it was found that the expected difference was not shown, but that full crops had been produced by the poorer manuring. The plan was accordingly altered, and the field divided into two halves, the crops on one half being grown without any manure, and being successively removed

Year	Rotation, No. 1. 4 acres	Rotation, No. 2. 4 acres	Rotation, No. 3. 4 acres	Rotation, No. 4. 4 acres
1885	Seeds	Roots	—	—
1886	Wheat	Barley	Seeds	Roots
1887	Roots	Seeds	Wheat	Barley
1888	Barley	Wheat	Roots	Seeds
1889	Seeds	Roots	Barley	Wheat
1890	Wheat	Barley	Seeds	Roots

off the land with the idea of removing its accumulated over-fertility, while on the other half manuring with decorticated cotton-cake and

maize-meal respectively is still continued, but much smaller amounts are used and only once in the rotation, viz. when the roots are being fed off. This plan has been continued from 1885 up to the present. The table on page 366 represents the cropping.

*Seeds.*—Red clover was sown among the barley early in May at the rate of 16 lb. per acre. The following year it was cut, for the first time in June, and the second time in the middle of August. The weights obtained in 1889 and 1890 are given in Table III.

TABLE III.—PRODUCE OF CLOVER HAY IN 1889 (ROTATION 1) AND 1890 (ROTATION 3) AFTER BARLEY.

PLOTS, $\frac{1}{2}$ -Acre	Manures	Produce per Acre							
		1889				1890			
		tons	cwt.	qr.	lb.	tons	cwt.	qr.	lb.
Manured once in the rotation by feeding off roots with dec. Cotton-cake and Maize-meal respectively.	1 { No manure (after barley—cotton-cake plot). . . }	4	1	0	18	2	17	0	4
	2 { No manure (after barley—maize-meal plot). . . }	4	6	0	14	3	0	0	24
	3 { No manure (after barley—artificial equivalent of cotton-cake dung plot). }	4	2	2	10	3	6	1	14
	4 { No manure (after barley—artificial equivalent of maize-meal dung plot). }	4	1	2	14	3	13	3	22
Unmanured since 1885.	5 { No manure (after barley—cotton-cake plot). . . }	3	17	2	18	2	19	1	2
	6 { No manure (after barley—maize-meal plot). . . }	3	16	1	4	3	7	0	2
	7 { No manure (after barley—artificial equivalent of cotton-cake dung plot). }	4	2	1	14	3	16	3	12
	8 { No manure (after barley—artificial equivalent of maize-meal dung plot). }	3	17	2	0	3	19	2	22

Although in the barley crop of 1888 preceding the clover of 1889, the manured half (plots 1, 2, 3, 4,) had shown much higher returns than the unmanured half, whilst there was indication of this also with the barley of 1889, the differences are not observable in the above clover crops.

*Wheat.*—After ploughing up the previous clover-root, 8 pecks per acre of Browick wheat were drilled late in October or early in November in each year, and the crop was cut and harvested August 15–28 the following year. The results are given in Table IV., page 368.

In both years, and more especially in 1889, there is evidence of the somewhat higher fertility of the plots comprising the manured half of the rotation. Also in 1890 the superiority of the cotton-cake to the maize-meal plots is indicated throughout. It might be mentioned here that in 1885 when wheat was last grown on Rota-

TABLE IV.—PRODUCE OF WHEAT IN 1889 (ROTATION 4), AND IN 1890 (ROTATION 1), AFTER CLOVER.

Plots ½-Acre	Manures	Produce per Acre—DRESSED CORN, 1889						Produce per Acre—DRESSED CORN, 1890								
		Head-Corn			Tail-Corn			Head-Corn			Tail-Corn					
		Weight	Bu- s- hels	Wei- ght per Bus- hel	Weight	Bu- s- hels	Wei- ght per Bus- hel	Weight	Bu- s- hels	Wei- ght per Bus- hel	Weight	Bu- s- hels	Wei- ght per Bus- hel			
		cwt. qr. lb.	lb.	lb.	cwt. qr. lb.	lb.	cwt. qr. lb.	lb.	lb.	cwt. qr. lb.	lb.	cwt. qr. lb.	lb.			
1 Manured once in the rota- tion by feeding off roots with dec. cotton- cake, and maize- meal, respec- tively.	3	(No manure (after clover—cotton- cake plot)	14 0 7½	27-22	57-88	2 24½	2-3	34-7	28 3 21	22 2 5	41-24	61-22	3 15	2-1	46-7	32 2 19½
		(No manure (after clover—maize- meal plot)	16 0 0½	30-34	59-07	2 7	1-6	39-0	31 0 19	21 1 26½	39-41	61-06	3 3½	2-0	43-0	30 3 15½
		(No manure (after clover—artificial equivalent of cot- ton-cake dung plot)	16 2 21	31-44	59-48	3 27	2-7	40-2	32 2 0½	21 3 11½	40-04	61-12	3 27	2-4	46-0	33 0 22½
		(No manure (after clover—artificial equivalent of maize-meal dung plot)	15 3 12½	29-86	59-5	3 23½	2-8	38-5	31 2 11½	20 3 14	38-35	60-69	3 8	2-0	45-0	34 0 7
5 Unman- ured since 1886	7	(No manure (after clover—cotton- cake plot)	13 1 27½	25-04	60-35	2 13½	1-8	39-0	24 3 21	20 1 8	37-66	60-43	3 20	2-3	45-0	30 2 16½
		(No manure (after clover—maize- meal plot)	15 0 10½	28-22	59-9	1 0 15½	2-8	45-2	27 0 8	18 3 4½	35-16	59-84	3 27½	2-5	43-5	27 3 23
		(No manure (after clover—artificial equivalent of cot- ton-cake dung plot)	14 3 11½	27-67	60-1	2 8½	1-6	39-5	25 1 24½	21 3 0	40-32	60-41	3 13½	2-2	43-7	31 0 26½
		(No manure (after clover—artificial equivalent of maize-meal dung plot)	14 1 3	26-71	59-86	2 0½	1-4	39-5	23 2 15	21 1 4	37-53	60-53	3 20	2-4	43-2	31 1 18



tion 4, the average produce was 45 bushels. That the season mainly, and not alone the exhausting effect of the crops grown and removed, has caused the lowering to 25 bushels, is shown by the much higher produce obtained on Rotation 1 in 1890.

*Barley.*—This crop followed roots. Over one half of the rotation mangel was grown without manure, and was carted off the land entirely. On the other half swedes were grown with 3 cwt. of mineral superphosphate per acre to insure a crop, and after weighing the produce, a portion (viz.  $2\frac{1}{2}$  tons per acre in 1888, and 7 tons per acre in 1889, as well as all the leaves,) of the crop was removed from each plot, so as not to enrich the land too much, and the remainder (about 6 tons per acre) was fed off by sheep during the winter as follows :—

Plot 1, with 400 lb. decorticated cotton-cake per acre.

Plot 2, with 400 lb. maize-meal per acre.

Plots 3 and 4, without purchased foods, but to the barley were subsequently applied artificial manures estimated to be equivalent to the cotton-cake and maize-meal dung respectively.

The sheep had also a little wheat-straw chaff (1 cwt. per acre) given to them when feeding off the roots.

After ploughing up the land, barley—8 pecks per acre—was drilled in spring (March 16 in 1889, and April 2 in 1890), red clover being sown over the plots early in May. The manures representing the artificial equivalents of the cotton-cake and maize-meal dung were applied to plots 3 and 4, the mineral portion at the time of sowing the barley, and the nitrogenous portion (in the form of nitrate of soda) when the corn was well up. The crop was cut and harvested August 14–30 in each year. The results are given in Table V., page 370.

It is the barley crop immediately following the consumption of cake and meal on the land with roots that has given the best indication, so far, of differences of manurial value between the cotton-cake and maize. But neither in 1889 nor 1890 is this as marked as before. Where artificial equivalents to these foods have been used the distinctions are clear, both in the plots of 1889 and of 1890. The plots 1 and 2 of 1889 seem, however, to give anomalous results, which may possibly be due in great part to the difficulty of manuring evenly with sheep when going over the land.

With the exception of these two plots, there are the same distinctions that have been previously observed in favour of cotton-cake and its artificial equivalent, as against maize-meal and its equivalent—as also between the manured and unmanured halves of the rotation.

*Roots.*—Mangel seed, 6 lb. per acre, was drilled over one half (the unmanured) of the rotation, on April 29 in both 1889 and 1890, and on the manured half, 3 lb. of swede seed per acre were drilled early in June with 3 cwt. of mineral superphosphate to ensure a crop. The mangel produced a fair crop, especially in 1890, the roots being ready to pull on October 10, but only by November 1,

TABLE V.—PRODUCE OF BARLEY IN 1889 (ROTATION 3) AND IN 1890 (ROTATION 2), AFTER (a) SWEDES FED OFF, (b) MANGEL CARTED OFF.

Plots of ½-acre	Manures	Produce per Acre—Dressed Corn, 1889						Produce per Acre—Dressed Corn, 1890													
		Head-Corn			Tull-Corn			Head-Corn			Tull-Corn										
		Weight	Buss-hels	Wght per Bus-hel	Weight	Buss-hels	Wght per Bus-hel	Weight	Buss-hels	Wght per Bus-hel	Weight	Buss-hels	Wght per Bus-hel								
		cwt. qr. lb.	lb.	cwt. qr. lb.	lb.	cwt. qr. lb.	lb.	cwt. qr. lb.	lb.	cwt. qr. lb.	lb.	cwt. qr. lb.	lb.	cwt. qr. lb.	lb.						
Manned once in the rotation by feeding off roots with dec.	1 After Swedes fed off with cotton-cake	14	3 11½	27.63	60.2	2	6½	1.4	46	19	1 10	21	0 20	43.41	64.65	1	26	1.1	50	23	3 14½
		14	2 6	29.78	64.73	1	2	7	45	17	0 16	19	2 0½	39.66	65.08	1	8	8	48	20	3 18
		17	3 22	37.56	63.48	2	14½	1.6	44	25	2 14	21	1 16½	43.76	64.76	1	8½	8	48	25	0 04
		16	3 15	31.62	61.62	1	4	7	45.5	21	1 15	17	2 6	35.84	64.85	26	6	6	46	18	3 5½
Unmanned since 1886.	5 { No manure (after mangel carted off—cotton-cake plot)	12	1 15	25.25	54.94	21½	5	5	46	13	3 25	18	2 27	38.59	64.39	1	17½	9	51	20	1 16
		13	0 2½	26.86	54.9	25	6	6	44.5	18	0 21	16	3 13	34.71	64.42	1	13	8	49	17	3 22
Unmanned since 1886.	6 { No manure (after mangel carted off—maize-meal plot)	14	8 18	30.34	55.03	24½	5	5	45	20	1 21	17	2 9½	36.81	65.00	1	10½	8	49.5	20	2 14
		14	1 24	29.17	64.78	23	5	5	46	19	0 20	15	3 23	32.54	64.92	27½	6	6	47	19	1 4½

TABLE VI.—PRODUCE OF SWEDES AND MANGEL IN 1889 AND IN 1890 AFTER WHEAT.  
SWEDES (ROTATION 2) (ROTATION 4)

Plots, 5-acre	Manure per acre	Produce per acre, 1889		Produce per acre, 1890					
		Roots		Leaves		Roots		Leaves	
		tons	cwt. qr. lb.	tons	cwt. qr. lb.	tons	cwt. qr. lb.	tons	cwt. qr. lb.
Manured once in the rotation by feeding off roots with decorticated cotton-cake and maize-meal respectively	{ 3 cwt. superphosphate (after wheat—cotton-cake plot) } { 3 cwt. superphosphate (after wheat—maize-meal plot) } { 3 cwt. superphosphate (after wheat—artificial equivalent of cotton-cake dung plot) } { 3 cwt. superphosphate (after wheat—artificial equivalent of maize-meal dung plot) }	12	8 0 16	2	0 3 18	tons	cwt. qr. lb.	tons	cwt. qr. lb.
		12	5 2 26	2	2 3 18				
		10	4 0 18	1	15 0 24	No crop		No crop	
		10	17 0 14	1	17 0 8				
Unmanured since 1885	{ No manure (after wheat—cotton-cake plot) } { No manure (after wheat—maize-meal plot) } { No manure (after wheat—artificial equivalent of cotton-cake dung plot) } { No manure (after wheat—artificial equivalent of maize-meal dung plot) }	15	7 2 4	4	4 2 4	10	6 0 4	3	18 3 6
		13	8 1 10	4	0 2 18	13	12 2 16	4	14 2 8
		12	4 0 8	3	11 1 20	14	8 3 24	4	13 0 2
		11	13 0 8	3	2 2 18	12	10 3 10	4	2 0 8

MANGEL

in 1889. The swede crop was pulled in 1889 on November 14, the crop being heavier than usual, but in 1890 (rotation 4) the swedes began to go off very much at the beginning of August, "finger and toe" disease manifesting itself very badly, and ultimately there was no crop at all on any of the four plots of this rotation.

The results obtained are given in Table VI., page 371.

The very fair crops of mangel taken off this land, although no manure whatever has been given to it since 1885, show that there is still much in the soil which is capable of removal by crops. At the same time the failure of swedes on rotation 4 in 1890, while mangel thrived without manure, opens up an interesting question as to the different nature of growth of these crops and the food they respectively feed on in the soil, and their methods of obtaining such food. It was on this same rotation (rotation 4) that the swedes in 1886 produced a very small crop, and the tops were entirely blighted. Mangel, on the other hand, produced however 17 to 19 tons per acre.

#### C. FURTHER EXPERIMENTS IN LANSOME FIELD ON THE COMPARATIVE MANURIAL VALUES OF DECORTICATED COTTON-CAKE AND MAIZE-MEAL.

These experiments began in 1885, and consist of six plots. The 4-course rotation is adopted, and manure is used only once in the rotation. In 1885 it was applied direct for the barley crop, but in 1889 the swedes grown in 1888 were fed off with sheep on all the plots. Plots 1 and 4, however, received no further manure, but on plot 2 the sheep had, as in the rotation experiments, 400 lb. per acre of decorticated cotton-cake, and on plot 5 400 lb. of maize-meal per acre, while on plots 3 and 6 decorticated cotton-cake-meal and maize-meal in quantity estimated to supply the same amounts of manurial ingredients as the cotton-cake and maize-meal dung respectively did, were severally spread as top-dressings just after the barley was sown. This was about March 15, 1889. Cloverseed (red and white mixed) was sown among the barley early in May. The barley crop was cut and harvested August 9-31, 1889, and the clover crop of 1890 cut twice, viz. on June 20 and August 19, 1890.

The results for the two years are given in Table VII. opposite.

Both in the barley crop of 1889 and in the succeeding clover of 1890, the highest produce has been obtained from plot 3, to which decorticated cotton-cake meal is applied direct as a manure. The results of the duplicate plots 1 and 4 confirm the observation of previous years that No. 1 more nearly represents the "unmanured yield." Maize-meal fed on the land has proved better than the same spread as manure.

These experiments on the poorer soil of Lansome Field appear likely to yield useful evidence to supplement the investigations in Stackyard Field, where the rotation experiments are in progress.

TABLE VII.—PRODUCE OF BARLEY IN LANSOME FIELD IN 1889 AFTER SWEDES FED OFF, AND OF CLOVER HAY IN 1890 AFTER BARLEY.

PLOTS ½ acre	Manure used per Acre for Barley in 1889	Produce of Barley per Acre—DRESSED CORN, 1889						Straw, Chaff, &c. per Acre	Produce of Clover Hay per Acre, 1890
		HEAD-CORN			TAIL-CORN				
		Weight	Bushels	Weight per Bushel	Weight	Bushels	Weight per Bushel		
1	Swedes fed off . . . . .	cwt. qr. lb. 13 2 27	27.73	lb. 55.5	qr. lb. 1 8	lb. 50	cwt. qr. lb. 18 0 14	2 11 16	
2	Swedes fed off with 400 lb. decorticated { cotton-cake . . . . .	16 2 15	34.08	54.66	2 19	48	24 1 26	2 8 3 4	
3	Swedes fed off and barley top-dressed with { decorticated cotton-cake meal, containing the same amount of manurial constituents as the dung in No. 2, but applied direct to the land . . . . .	18 2 22	36.09	58.03	2 13	49	32 2 11	3 10 3 4	
4	Swedes fed off . . . . .	16 1 24	33.53	55.0	1 3	48	17 2 17	2 19 2 16	
5	Swedes fed off with 400 lb. maize-meal . . . . .	17 2 4	35.65	55.09	1 4	50	19 2 17	2 13 3 16	
6	Swedes fed off and barley top-dressed with { maize-meal, containing the same amount of manurial constituents as the dung in No. 5, but applied direct to the land . . . . .	15 1 16	31.28	55.11	22	48	16 2 20	2 12 1 8	

## D. EXPERIMENTS ON PERMANENT PASTURE.

Four plots were laid down in Great Hill Bottom Field in 1886, and two others, in 1888, with mixtures of grass and clover seeds at varying cost, as follows :

						Per acre	
						s.	d.
1886	Plot 1A	9,869,000	seeds	without	rye-grass, costing	20	10
"	"	1B 14,968,000	"	with	"	17	6
"	"	2A 14,394,000	"	without	"	29	11½
"	"	2B 19,447,000	"	with	"	24	3½
<hr/>							
1888	"	3A 16,000,000	"	without	"	26	0
"	"	3B 8,000,000	"	without	"	13	0

One half of each plot is manured yearly with 5 cwt. per acre decorticated cotton-cake-meal and mown for hay, the other is fed off with sheep consuming the same amount of cake on the plots. In 1889 and 1890 the meal was sown in March on the halves to be mown, and two cuttings were taken, the first near the end of June, the second early in September. The sheep feeding off the grass went over it four times in 1889 (beginning August 4, June 1, July 13, and September 10), and three times in 1890 (beginning May 12, June 28, August 27), the first time without cake and afterwards with it.

The produce of the hayed plots is given in Table VIII.

TABLE VIII.—PRODUCE OF HAY PER ACRE IN GREAT HILL BOTTOM.

Plot	Produce per acre														
	Total produce of the three years 1886-88		Produce in 1889		Produce in 1890										
	tons	cwt.	qr.	lb.	tons	cwt.	qr.	lb.		s.	d.				
1A	8	18	2	25	3	9	1	0	2	8	3	10	Without rye-grass, cost per acre	20	10
1B	8	9	0	26	2	15	0	4	2	3	1	4	With	17	6
2A	8	18	1	6	3	6	1	0	2	8	0	10	Without	29	11½
2B	9	4	0	24	2	17	2	12	2	2	0	0	With	24	3½
<hr/>															
1888															
3A	1	10	0	17	4	19	1	25	3	4	2	18	Thick seeding	26	0
3B	1	0	1	25	5	0	3	6	3	6	1	23	Thin	13	0

## E. MISCELLANEOUS EXPERIMENTS.

1. *Varieties of Oats.*

Three varieties, viz.—“New Zealand,” “Cluster,” and “American Triumph” were sown side by side in Road Piece Field in 1889 at the rate of 9 pecks per acre and manured alike. The first two varieties were ready to cut on August 8, but the American one not until August 22. The harvest results were :—

Plots $\frac{1}{2}$ acre	PRODUCE OF OATS PER ACRE		DRESSED CORN		
	Weight		Bushels	Weight per Bushel	Straw, Chaff, &c
1. New Zealand Oats . . .	cwt. gr. lb.			lb.	cwt. gr. lb.
2. "Cluster" Oats . . .	17 3 10	45.93	43.5	23 1 22	
3. "American Triumph" Oats	21 0 14	59.9	39.5	30 1 6	
	17 3 26	59.17	34.04	39 3 26	

### II. Varieties of Barley.

Two varieties of barley, "Prize Prolific" and "Goldenthorpe," were drilled side by side in Butt Furlong on March 20, 1889, at the rate of 8 pecks of seed per acre. The results at harvest were:—

Plots $\frac{1}{2}$ acre	PRODUCE OF BARLEY PER ACRE		DRESSED CORN		
	Weight		Bushels	Weight per Bushel	Straw, Chaff, &c.
1. "Prize Prolific" Barley .	cwt. gr. lb.			lb.	cwt. gr. lb.
2. "Goldenthorpe" Barley .	18 2 8	40	52	25 1 22	
	18 2 24	39.4	53.12	29 1 4	

### III. Experiment on Liming.

Three acres were selected early in 1889 in Lansome Piece, a field which was believed to be in need of liming, as indicated by previous swede crops showing a tendency to "finger and toe." On Jan. 23-25, 1889, two of the three acres were limed, the one with four tons, the other with two tons of lime per acre, the third acre being left unlimed. The plots were again divided and manured as shown in the following plan, swedes being drilled in—3 lb. seed per acre—on June 14.

#### MANURES PER ACRE.

6	5	4	3	2	1
4 tons lime per acre		2 tons lime per acre		no lime	
1 cwt. nitrate of soda	3 cwt. superphosphate	3 cwt. superphosphate	5 cwt. basic cinder	3 cwt. superphosphate	5 cwt. basic cinder
		1 cwt. nitrate of soda	1 cwt. nitrate of soda		
9		8		7	
4 tons lime per acre		2 tons lime per acre		no lime	

The swedes were pulled and weighed on December 13, 1889. The results were :—

Plot	Manures used per Acre		Weight of Roots (Swedes) per acre				
			tons cwt.	qr.	lb.		
7	Unlimed	{	No manure . . . . .	11	13	1	4
1			5 cwt. basic cinder . . . . .	13	13	1	20
2			3 cwt. superphosphate . . . . .	13	8	0	0
8	2 tons lime per acre	{	No manure . . . . .	14	5	0	0
3			5 cwt. basic cinder . . . . .	14	9	1	20
			1 cwt. nitrate of soda . . . . .				
4			3 cwt. superphosphate . . . . .	16	6	3	12
	1 cwt. nitrate of soda . . . . .						
9	4 tons lime per acre	{	No manure . . . . .	11	7	0	0
5			3 cwt. superphosphate . . . . .	14	5	1	20
6			1 cwt. nitrate of soda . . . . .	16	3	3	12

Notwithstanding the liming there were on all the plots patches of roots affected with "finger and toe."

From a comparison of the results it would appear that the dressing of four tons of lime to the acre had not been effectual, but that of two tons had produced decided benefit in each case. A similar case of good resulting from the application of two tons of lime per acre, and—for the first year at least—of no good being done by four tons of lime, was observed in the experiments of the Royal Manchester Liverpool and North Lancashire Society three years back.

As between "basic cinder" and superphosphate there is no definite evidence of superiority of one to the other, since comparing plots 4 and 6 the increase of crop produced over plots 1, 2, and 3 appears to be due to the nitrate of soda rather than to the phosphatic element.

#### IV. *Experiments on Potatoes with Box and Yard Manure (made with different foods), and with artificial manure.*

After the conclusion of the bullock-feeding experiments of the winter of 1888-9, the dung was removed out of the boxes and the open yard. It was thought that it might be interesting to keep the different lots separate and grow with them a crop of potatoes. On one side of the boxes four bullocks had been feeding for 145 days on roots and hay with additional food as follows :—linseed cake 2·88 lb., barley 4 lb., and *decorticated* cotton-cake 3·30 lb. per head daily ; on the other side four others had the same food except that *undecorticated* cotton-cake was substituted for decorticated. In the yard, bean-meal was consumed instead of cotton-cake, but the manure made here was of course of indefinite nature, and not like that made in the boxes, the approximate composition of which



could be ascertained. 12 tons of dung to the acre were used in each case. Side by side with these an artificial mixture was tried, composed as follows :—

3 cwt. mineral superphosphate	}	8 cwt. per acre, costing 35s. 6d. per acre.
3 cwt. kainit		
2 cwt. sulphate of ammonia		

The potatoes (magnums) were planted on May 9, 1889, in Road Piece Field, the manure having been in all cases applied to the land previously. The crop was dug and weighed on September 26 and 27. The following were the results :—

Plot	Manure per acre	Produce per acre
		tons cwt. qr. lb.
1	{ 12 tons dung made from decorticated cotton-cake . . . . . }	8 13 1 20
2	{ 12 tons dung made from undecorticated cotton-cake . . . . . }	7 6 3 12
3	{ 12 tons farm-yard manure . . . . . }	7 16 2 8
4	{ 3 cwt. superphosphate . . . . . }	9 9 3 12
	{ 3 cwt. kainit . . . . . }	
	{ 2 cwt. sulphate of ammonia . . . . . }	

By this it will be seen that the artificial manure produced the largest crop, and it is worthy of note that there were no more small potatoes in this produce than in any of the others. The most interesting part of the experiment, however, is that which brings out the superior manurial effect of the decorticated cotton-cake dung—as against that from the undecorticated cake.

The composition of the farmyard manure used on plot 3 was too indefinite to justify certain conclusions being drawn, but, as mentioned, the animals in the yard had bean-meal fed to them largely.

V. *Lathyrus sylvestris*.

A small plot 8 × 8 feet was sown with the seed of this plant on April 6, 1888, but it lay dormant until August, when the plant began to come up. It gave no crop, however, until the next year, when it was cut green on August 29, 1889, the yield being 35 lb. green crop, or, if calculated to the acre, 10 tons 12 cwt. 2 qr. 22 lb. green produce per acre. This plot being so small, a larger one was sown in April 1890. Although the seed duly germinated, there was no crop fit to cut in 1890.

It should be borne in mind that the price of the seed was no less than 2l. 2s. per lb., and that for sowing an acre as much as 50 lb. of seed are recommended, an outlay of over 100l. an acre !

The produce of this same plot in 1890, also cut and weighed green, was :—

Plot	Produce of plot	Produce per acre				
		lb.	tons	cwt.	qr.	lb.
8 x 8 ft. }	1st cutting, July 16 . . . . .	38	11	10	3	20
	2nd cutting, September 12 . . . . .	17	5	3	1	7
	Total . . . . .	55	16	14	0	27

In addition to the experiments here recorded there are in progress experiments on the duration of the life of clovers, and of different varieties of grasses and their respective yields. These are separately reported on by the Consulting Botanist to the Society.

During the winter months feeding experiments both with bullocks and with sheep were carried out at Woburn in 1889 and 1890. These are separately recorded also.

Crawley Mill Farm is situated near Woburn, Bedfordshire; the soil is a very light reddish loam, about 9 inches deep, with a subsoil of almost pure sand.

**RAINFALL at WOBURN during 1889 and 1890, taken daily at CRAWLEY MILL FARM.**

	Inches			Inches	
	1889	1890		1889	1890
January . . . . .	1.09	1.97	July . . . . .	2.84	2.73
February . . . . .	1.46	.82	August . . . . .	1.55	1.47
March . . . . .	1.99	1.78	September . . . . .	1.98	.46
April . . . . .	2.43	1.61	October . . . . .	3.04	1.43
May . . . . .	4.45	1.34	November . . . . .	.97	2.32
June . . . . .	1.04	1.69	December . . . . .	.83	.18
			Total . . . . .	23.67	16.80

**RAINFALL in 1886, 1887, 1888, 1889, 1890.**

	1886.	1887.	1888.	1889.	1890.
Inches . . . . .	25.05	15.04	23.94	23.67	16.80

**DURING the HARVEST MONTHS of AUGUST and SEPTEMBER the RAINFALL was—**

	1886.	1887.	1888.	1889.	1890.
Inches . . . . .	2.61	2.62	3.19	3.53	1.93

## FIELD EXPERIMENTS CONDUCTED IN 1889 AND 1890 BY LOCAL AGRICULTURAL SOCIETIES.

THE three societies which, in conjunction with the Royal Agricultural Society of England, began in 1886 to take up experimental work in the field continued their investigations during 1889 and 1890. These societies were the following :

The Essex Agricultural Society.

The Royal Manchester, Liverpool, and North Lancashire Agricultural Society.

The Norfolk Chamber of Agriculture.

### I. ESSEX AGRICULTURAL SOCIETY.

(*Abstract of Report of Mr. Bernard Dyer, B.Sc., F.C.S., F.L.S., &c., Consulting Chemist to the Society, and Mr. E. Rosling, F.R.M.S., of Melbourn, Chelmsford.*)

In 1889, as in previous years, there were two sets of experiments :—

A. Continuation of the mangel experiments of 1888, by the growth of oats (unmanured), in order to ascertain the after-effects of the manures applied for the mangel.

B. Experiments in mangel manuring differing somewhat from the previous experiments.

A.—In both 1887 and 1888 it was found that the heaviest and most highly-manured mangel crop was followed by the best oat crop. These results are practically confirmed once more by the experiments of 1889.

As reported in 1888, there was a partial failure of the mangel crop of that year, which, together with other circumstances, prevented the drawing of satisfactory conclusions so far as the manuring for mangel was concerned. Oats followed upon the same land, and the following table (page 380) gives the summary of the results for the two years.

From a consideration of these results, it appears that the use of dung alone gave a return of less than half a ton of mangel (owing, to a great extent, to failure of plant), and an increase of  $12\frac{1}{2}$  bushels of oats and 6 cwt. straw. The use of artificials without nitrate of soda, in addition to dung, gave nearly 3 tons of mangel more than dung alone, but not an appreciably larger oat crop. Dressings of artificials, including in each case 2 cwt. of nitrate of soda in addition to dung, gave about 4 tons of mangel more than dung alone, 3 bushels more of oats, and 4 cwt. more straw. When the artificial dressing added to the dung included 4 cwt. of nitrate of soda per acre, the increase over dung alone was, on the average, nearly  $6\frac{1}{2}$  tons of mangel and 12 bushels of oats.

PLOT	Manures used for Mangel in 1888 Average yield per acre	1888 Mangel			1889 Oats			
					Grain		Straw	
		tons	cwt.	qr.	bushels	tons	cwt.	qr.
1	No manure (2 plots) . . . . .	14	10	3	52·8	1	8	2
2	Dung, 12 tons per acre . . . . .	14	19	0	65·3	1	15	0
3	{ Dung, with artificials, <i>excluding</i> ni- trate of soda (3 plots) . . . . . }	17	17	0	65·6	1	17	3
4	{ Dung, <i>with</i> 2 cwt. per acre nitrate of soda, and with or without other artificials (4 plots) . . . . . }	19	2	2	68·5	1	18	5
5	{ Dung, <i>with</i> 4 cwt. per acre nitrate of soda, and with or without other artificials (4 plots) . . . . . }	21	6	3	77·0	1	18	0
6	{ Nitrate of soda, 4 cwt. per acre, with or without other artificials, but <i>without</i> dung . . . . . }	17	19	2	66·3	1	14	0

[*Note.*—The artificials other than nitrate of soda were:—Superphosphate 3 cwt., basic cinder 4 cwt., guano 2 cwt., 4 cwt., and 6 cwt. per acre.]

The plots without dung, but with artificial dressings, each including 4 cwt. of nitrate of soda per acre, gave, on an average,  $3\frac{1}{2}$  tons of mangel, about  $10\frac{1}{2}$  bushels of oats, and 5 cwt. more straw per acre than the average of the unmanured plots. These results clearly confirm the experience arrived at in the two preceding years on this farm—viz., that the heavy manuring of mangel with artificials does *not* injuriously affect the land for the next crop.

A table is given in the Report showing the cost of the manures, and of the increase in crops due to them. Reckoning roots at 10s. per ton, oats at 2s. a bushel, and straw at 2l. per ton, it appears that, if dung be charged at 5s. per ton, the only profits shown in the two years are where artificials were used, dung alone making a loss. Dung and 4 cwt. nitrate of soda made a profit of 2l. 1s. per acre; dung and 2 cwt. guano, a profit of 3l. 4s. 6d. The heavy dressing of 4 cwt. guano and 4 cwt. nitrate, in addition to dung, gave a loss. On the undunged plots, 4 cwt. nitrate of soda alone gave a total profit of 1l. 3s. 5d., the addition of phosphatic manures bringing the profit up to 1l. 15s. 6d.

The results, taken with those of previous years, seem to point out that dung, as regards its effect on the two crops, is too dearly valued at 5s. per ton as a fertiliser; although, as will be seen in the following account of the 1889 mangel experiments, dung has, sometimes, other and not less valuable functions than those of a mere fertiliser.

B.—The experiments on mangel were carried out on a gravelly loam containing abundance of lime in the form of chalk-stones. It was in another part of the field used for the experiments of 1887. The manures were this time restricted to dung, Peruvian guano of cheap quality, and nitrate of soda. The guano was applied before sowing, and when 4 cwt. of nitrate were used, 1 cwt. was sown before the seed, the remainder in three top-dressings of 1 cwt. each, at

intervals of about a month. When 2 cwt. of nitrate only were used, they were applied in two top-dressings.

There were three plots under each of six different systems of treatment. The average results of each set were:—

Manures per acre	Mangel Yield per acre tons cwt. qr.	
No manure (mean of three plots) . . . . .	9	14 0
12 tons dung (mean of three plots) . . . . .	10	10 2
12 tons dung and 2 cwt. nitrate of soda (mean of three plots) . . . . .	14	0 3
12 tons dung and 4 cwt. nitrate of soda (mean of three plots) . . . . .	15	8 3
No dung: 6 cwt. guano and 2 cwt. nitrate of soda (mean of three plots) . . . . .	14	10 1
No dung: 6 cwt. guano and 2 cwt. nitrate of soda (mean of three plots) . . . . .	15	13 0

Dung alone gave an increase of  $16\frac{1}{2}$  cwt. roots, as compared with no manure. The addition to the dung of 2 cwt. nitrate of soda raised the increase to 4 tons  $6\frac{3}{4}$  cwt., while the addition to the dung of 4 cwt. nitrate increased it to 5 tons  $14\frac{3}{4}$  cwt. Roughly speaking, the dung was, manurially, a failure; but the addition of 2 cwt. nitrate, at a cost of under 1*l.*, gave  $3\frac{1}{2}$  tons more roots, and that of 4 cwt. nitrate, at a cost of under 2*l.*, gave nearly 5 tons more roots than dung alone. On the undunged plot, the dung was replaced by guano and nitrate of soda—6 cwt. of the former, and 2 cwt. and 4 cwt. respectively of the latter. The increase in roots in these cases did not cover the cost of the manures, though experience on this land renders it probable that the deficit will be more than recovered in the oats of the next year.

But the most interesting feature in the Report relates to the indirect value of dung under special conditions. When the plant was in the seed-leaf it was overtaken by drought, which punished chiefly the upper part of the field. The seedlings were observed in many spots to flag and die off, this being traced to an attack of grubs at the roots. The plant, in fact, died off to such an extent that large patches were left in the field, which remained bare all the season, and had to be excluded in weighing up the crops. At the time (late autumn) at which I visited the field in conjunction with the experimenters, it presented a curious and very interesting appearance, by reason of the striking symmetry in the areas of "gap" or bare soil, and the sharp way in which they seemed to be almost ruled off *en bloc* from the well-clothed areas, on at least three sides of each. The experimental plots were situated in the midst of a large field all cropped with mangel, and *all dunged*, save for the undunged, experimental plots. The bare regions referred to were almost sharply confined to certain of these undunged plots—viz., all those in the upper half of the field; while a good plant grew and matured on the dunged plots lying between them, and on the non-experimental, dunged ground above them and

on either side. It was impossible to doubt that the absence of the dung was closely connected with the failure of plant, and its presence with the comparative immunity from failure. As the actual cause of the failure was grub, the advantage gained by the dunged plots would seem to have been due to the more rapid and vigorous growth of the dunged plant, or to the coming up and survival of more seedlings. But whether this is to be attributed to a greater power of holding moisture in dunged land, or to greater warmth caused by fermentation, or to yet other causes, it is difficult to suggest. But the experience was so striking as to lead the experimenters to advise that, whatever results may be shown by mere artificial manuring, no farmer, in the dry climate of Essex, should abandon farmyard dung in growing mangel. The rainfall for the year was only 21.42 inches. The mangel experiments will probably be continued another year.

## II. THE ROYAL MANCHESTER, LIVERPOOL, AND NORTH LANCASHIRE AGRICULTURAL SOCIETY.

(Abstract of Report of Mr. Alf. Smetham, F.I.C., &c., Consulting Chemist to the Society.)

THE experiments, commenced in 1885, at Saltney, near Chester, and in 1886, at Rostherne, on Lord Egerton of Tatton's Estate, have been continued on the lines indicated in the Report for 1888.<sup>1</sup>

At Saltney the experiments were devised with a view to determine the best and most economical mixture of seeds for one, two, and three years' ley, and for permanent pasture. The results of the experiments on the plots laid down for one and two years have already been described, and for practical purposes need no further comment, except it be to note that Plots 8, 9, and 11, sown for two years' ley, have stood sufficiently well to serve for three years' ley.

Two plots only were sown for three years' ley, Plot No. 7 having produced the larger crops in the first two years. This superiority was fully maintained in the third year, as will be seen from the following table:—

	Dry matter per acre in produce.						Total dry matter per acre in three years' produce.		
	1887		1888		1889				
	cwt.	qr. lb.	cwt.	qr. lb.	cwt.	qr. lb.	cwt.	qr.	lb.
Plot 6.	34	1 0	22	0 22	18	0 22	74	2	16
Plot 7.	39	0 0	25	1 9	21	0 0	85	1	9

The cost of seeding being the same in both instances, the following mixture (plot 7) stands out as the one that has proved best for three years' ley.

2 lb. Italian rye-grass.	2 lb. timothy.
5 lb. perennial rye-grass.	1 lb. crested dogstail.
5 lb. cocksfoot.	4 lb. cowgrass.
3 lb. meadow fescue.	1½ lb. white clover.
2 lb. meadow foptail.	1½ lb. alsike clover.
1 lb. hard fescue.	

<sup>1</sup> See Journal, Vol. xxv., s.s., 1889, p. 295.

The five plots sown for permanent pasture continue to make good progress. Nos. 1 and 3 appear to be the best. Taking the quality and the yield of grass together, No. 3 seems to be a more serviceable mixture than No. 1. These mixtures are as follows :—

No. 1.		No. 3.	
24 lb. Devonshire ever-green rye-grass.	2 lb. Italian rye-grass.	4 lb. meadow foxtail.	
4 lb. crested dogstail.	6 lb. cocksfoot.	3 lb. white clover.	
4 lb. wild white clover.	5 lb. meadow fescue.	1 lb. red clover.	
$\frac{1}{2}$ lb. sweet vernal grass.	3 lb. tall fescue.	1 lb. alsike clover.	
	3 lb. timothy.		

The costs of these mixtures were, in 1885, No. 1, 16s. 9d. per acre, and No. 3, 11. 8s. 1d. per acre.

The wild white clover in No. 1 continues to spread very rapidly. Mr. Holland, the Society's Botanist, in his report, speaks of its absolutely perennial character.

At Rostherne the experiments on grasses, commenced in 1887, are conducted in duplicate, with the exception that on one-half of the field the seeds were sown with oats, and on the other with wheat. Each of these plots was in 1888 divided into two equal parts, one of which was grazed, and the other mown and converted into hay. In 1889 the hurdles were moved, so that half of the portions mown in 1888 should be grazed, and half of the portions grazed in 1888 should be mown. In 1890 the hurdles were moved back to their original position again.

Thus, four divisions of the land were obtained :—

- (1) One portion continuously mown.
- (2) " " continuously grazed.
- (3) " " first mown, then grazed and mown alternately.
- (4) " " first grazed, then mown and grazed alternately.

The following table gives the results up to 1890.

**ROSTHERNE.—WEIGHTS OF HAY PER ACRE, 1888, 1889, 1890.**

*Plots seeded down with Wheat in 1887.*

Plot	Continuously mown						mown 1888 grazed 1889 mown 1890		grazed 1888 mown 1889 grazed 1890			
	1888		1889			1890		1890		1889		
	cwt.	qr.	cwt.	qr.	lb.	cwt.	qr.	cwt.	qr.	cwt.	qr.	lb.
A	47	0	40	0	0	23	0	22	2	22	2	4
B	31	0	20	0	0	16	0	22	0	14	0	0
C	38	0	28	0	0	17	0	24	0	18	0	0
D	34	2	30	0	0	19	0	23	0	17	0	0

*Plots seeded down with Oats in 1887.*

	30	0	32	0	0	26	0	25	0	36	1	0
L	30	0	32	0	0	26	0	25	0	36	1	0
K	29	0	29	2	16	23	0	21	0	27	1	0
J	33	2	37	1	0	26	0	24	0	29	2	4
I	33	0	36	0	0	25	0	26	0	25	0	0

It is noticeable that the mown portions of the field show considerably thicker roots than the grazed portions. Lucerne and sainfoin have almost entirely disappeared.

A comparison of the above figures shows very clearly the deteriorating effect of grazing in the first year. The weights of hay in 1889 were much less on the plots grazed in 1888 than where the plots were mown each year. On the other hand, alternate grazing and mowing, after mowing in the first year, has caused no falling off of produce.

		cost of seeding per acre	
		<i>s.</i>	<i>d.</i>
Plots A and L	are for permanent pasture without rye-grass	. . .	43 10
" B " K "	" " " with "	. . .	31 7
" C " J "	" four years' ley without "	. . .	30 6
" D " I "	" " " with "	. . .	25 1

Mixtures for two years' ley were also sown in the same field. The results have been :—

		Sown with wheat		
		Dry matter in 1888	Dry matter in 1889	Total in two years
		cwt. qr. lb.	cwt. qr. lb.	cwt. qr. lb.
Plot E	.	29 2 15	24 2 0	54 0 15
Plot F	.	25 1 14	19 0 18	44 2 4

		Sown with oats		
		Dry matter in 1888	Dry matter in 1889	Total in two years
		cwt. qr. lb.	cwt. qr. lb.	cwt. qr. lb.
Plot H	.	25 1 26	28 1 7	53 3 5
Plot G	.	23 2 16	20 3 21	44 2 9

The mixtures were as follows :—

*Plots E and H.*—6 lb. cocksfoot, 10 lb. timothy, 2 lb. perennial red clover, 2 lb. alsike clover, 1 lb. white clover. Cost per acre, 13*s.* 8*d.*

*Plots F and G.*—6 lb. Italian rye-grass, 4 lb. cocksfoot, 2 lb. meadow fescue, 2 lb. tall fescue, 2 lb. timothy, 2 lb. perennial rye-grass, 4 lb. red clover, 1½ lb. white clover, 1½ lb. alsike clover, 1 lb. trefoil. Cost per acre, 17*s.* 3*d.*

It will thus be seen that the plots in which the rye-grasses have been replaced by other grasses have yielded the largest quantities of hay in both the first and second seasons.

### III. NORFOLK CHAMBER of AGRICULTURE.

(*Abstract of Report of Mr. F. I. COOKE, of Flitcham, King's Lynn.*)

#### *Experiments upon Wheat.*

The experiments in 1889 and 1890 included an exact repetition of those of 1888 upon wheat, which have been already recorded in the Journal.<sup>1</sup> The wheat was grown after seeds, and in the ordinary four-course rotation of the county. The main object in view was to find what manure, or mixture of manures, is, in the absence of

<sup>1</sup> Vol. xxv., s.s., p. 290.



farmyard manure, the most economical to use for wheat. The trials were carried out at Cawston, at Flitcham, and at Bolwick. The Cawston land is a very poor, light, surface-soil of some 5 to 6 inches in depth, upon a sandy subsoil; that of Flitcham, a thin, light, and hungry top-soil, upon the Upper Chalk; that of Bolwick a deep and rich loam, resting upon a white and sandy subsoil.

The following table gives the most prominent results obtained in 1889.

WHEAT AFTER ROTATION SEEDS, 1889.

Plot	Manures per acre	Place of experiment	Produce per acre	
			Head-corn	Straw
			bushels	cwt. qr. lb.
1	Nothing . . . . .	Cawston . .	22·18	21 0 13
		Bolwick . .	35·46	30 0 10
		Flitcham . .	27·50	20 0 10
2	{ 4 cwt. rape-cake (sown in autumn) . . . . .	Cawston . .	26·29	28 2 2
		Bolwick . .	40·62	33 3 20
		Flitcham . .	27·96	23 1 26
4	{ 4 cwt. rape-cake . . . . . 1 cwt. muriate of potash (sown in autumn) . . . . .	Flitcham . .	34·53	30 0 10
5	{ 4 cwt. rape-cake . . . . . 2 cwt. superphosphate . . . . . 1 cwt. muriate of potash (sown in autumn) . . . . .	Cawston . .	30·62	34 0 12
		Flitcham . .	29·21	23 2 8
14	10 loads dung . . . . .	Flitcham . .	37·96	28 2 8

The wheat at Cawston in no case gave a profit from the manures, although the season could scarcely be called unfavourable for such land. No manure proved thus the most economical of all.

The highest yield (nearly 31 bushels per acre), and the best quality of grain, were obtained from 4 cwt. rape-cake, 2 cwt. superphosphate, and 1 cwt. of muriate of potash (plot 5).

At Bolwick, with the exception only of the unmanured plots, and those which received either superphosphate or potash, or both of these minerals, the whole of the plots were levelled with the ground before the wheat was ripe. In no case did the increase of produce warrant the expenditure on the manures.

At Flitcham, as usual, the most notable results were obtained from applications of potash. Thus, whilst 4 cwt. of rape-cake alone gave 28 bushels of grain, and the same rape-cake with nitrate of soda and sulphate of ammonia 29 and 28 bushels respectively, the addition of 1 cwt. of muriate of potash to the rape-cake, whether with or without a dressing of superphosphate, produced 34 bushels per acre of wheat. Or, in other words, 1 cwt. of muriate of potash, costing 8s. 6d., judiciously applied, increased the yield of wheat by

6 bushels per acre. Farmyard manure, too, here had much better success than at the other stations. At all three stations, in 1889, much more markedly than in 1888, the rape-cake proved itself a safer medium for the application of the requisite nitrogen than the more soluble nitrogenous manures.

The main results obtained in 1890 were:—

### WHEAT AFTER ROTATION SEEDS, 1890.

Plot	Manures per acre	Place of experiment	Produce per acre			
			Head-corn	Straw		
			bushels	cwt.	qr.	lb.
1	Nothing . . . . .	Cawston . .	26·87	29	1	4
		Bolwick . .	31·40	27	0	21
		Flitcham . .	25·93	23	3	20
2	{ 4 cwt. rape-cake (sown in autumn) . . . . .	Cawston . .	30·31	30	2	4
		Bolwick . .	34·37	30	0	0
		Flitcham . .	28·59	26	1	0
3	1 cwt. sulphate of ammonia .	Cawston . .	29·06	30	3	16
		Flitcham . .	31·56	31	0	8

At Cawston the wheat stood up well, but both at Flitcham and Bolwick it was much beaten down. Here the best money return was from using simply 1 cwt. per acre of sulphate of ammonia. Rape-cake gave the same increase, but at a higher cost. The land at Bolwick gave evidence of the beneficial use of mineral manures, but in no case was there an adequate return for the manure. At Flitcham similar results to those at Cawston were obtained, an outlay of 12s. for 1 cwt. per acre of sulphate of ammonia producing an increase of 5 bushels of wheat and 7 cwt. of straw per acre.

*Experiments to test the Value upon Wheat after Rotation Seeds of the unexhausted residue of Manures applied for Mangel in 1886, no Manure having been applied since that date. (Whitlingham Farm.)*

Plot	Manures per acre applied to Mangel in 1886	Produce per acre, 1889			
		Head-corn	Straw		
		bushels	cwt.	qr.	lb.
1	20 loads dung . . . . .	33·75	33	0	24
2	{ 10 loads dung . . . . .	33·12	30	0	10
6	{ 4 cwt. superphosphate . . . . .	32·34	31	0	18
	{ 2 „ nitrate of soda . . . . .				
	{ 3 „ common salt . . . . .				

When, in 1886, the very large dressing of twenty loads of dung was applied to Plot 1 for mangel, but without giving a return in the yield of roots at all adequate to the supplies of plant-food thus

given to the soil, it was determined to find how much of the unexhausted residue of the dung left after the mangel crop was removed could be recovered in future crops. Three plots, accordingly, were carried through the entire four-course rotation. The total results obtained during the four years may be summarised as follows:—

RESULTS OBTAINED IN 1886, 1887, 1888, AND 1889.

Plot	Manure used for mangel in 1886	1886	1887	1888	1889
		Mangel tons	Barley bushels	Seeds (Green produce) tons	Wheat bushels
1	20 loads dung . . . . .	23	43	9 $\frac{1}{2}$	33 $\frac{3}{4}$
2	{ 10 loads dung . . . . . 2 cwt. nitrate of soda . . . }	27	41 $\frac{1}{4}$	8 $\frac{1}{4}$	33
6	{ 4 cwt. superphosphate, ni- trate of soda, and salt . . }	25	38 $\frac{1}{2}$	8	32 $\frac{1}{4}$

The soil is of a light and porous nature, and to this, doubtless, is due the apparently enormous loss of fertilising matter in the dung—matter containing probably as much nitrogen as would be found in 12 cwt. of nitrate of soda, besides phosphates and potash. It is never well to allow too much emphasis to be laid upon the results of a single experiment, especially when the outcome is very unexpected. It may be well to observe, however, that the soil of the three plots in question has all along given every indication of evenness of character, and that the utmost accuracy has been observed throughout the experiments, so that the record is a record of fact, whatever may be the explanation.

These results find a parallel in the case of the Woburn experiments upon the residual values of manures, and seem to indicate that upon light lands any great amount of capital sunk in the soil in the form of a heavy dressing of farmyard manure applied at one single time is not likely to produce a return in future crops.

*Experiments upon Barley (after Swedes carted off).*

In 1889 one series was carried out at Bolwick, but, the unmanured plots yielding very high returns, the influence of the manures was not clearly marked. One point is worthy of notice—that common salt had a weakening rather than a strengthening effect upon the straw, the corn of the plots where it was used being more laid than on the others.

In 1890 the experiment was repeated at Cawston, and a capital barley crop was reaped.

The main results are recorded in the table on page 388.

The unmanured produce was high; superphosphate and muriate of potash—when without nitrogen—gave no increase; but 1 $\frac{1}{2}$  cwt. of nitrate of soda gave the most economical results of all, both in grain and straw—15 more bushels of corn being obtained, at a cost

Plot	Manures per acre	Head-corn	Straw		
		bushels	cwt.	qr.	lb.
1	No manure . . . . .	32·61	20	3	26
2	{ 1 cwt. nitrate of soda . . . . . 2 „ superphosphate . . . . . }	43·51	29	2	16
6	{ 1 $\frac{1}{3}$ cwt. sulphate of ammonia . . . . . 2 „ superphosphate . . . . . }	42·81	27	3	12
8	{ 1 „ muriate of potash . . . . . 1 $\frac{1}{2}$ „ nitrate of soda . . . . . }	47·03	29	3	8
9	{ 1 $\frac{1}{2}$ „ „ „ . . . . . 3 $\frac{1}{2}$ „ salt . . . . . }	44·60	29	2	6
10	{ 2 „ superphosphate . . . . . 1 „ muriate of potash . . . . . }	30·46	21	2	20
14	{ Roots folded with sheep and a dressing of 3 $\frac{1}{2}$ cwt. of fish salt . . . . . }	46·32	28	3	20

of about 14s. Nitrate of soda gave a better return than sulphate of ammonia, and the addition of salt to nitrate of soda proved of no benefit. No better result was gained by folding sheep on the roots than with 1 $\frac{1}{2}$  cwt. per acre of nitrate of soda.

*Experiments upon Mangel after Wheat. The Wheat had received ten Loads per Acre of Dung (Bolwick Farm). The results in 1889 were:—*

Plot	Manures applied per acre						Roots per acre			Tops per acre				
	Super-phosphate	Common salt	Nitrate of soda	Nitrate of soda (top-dressing)	Muriate of potash	Dung								
	cwt.	cwt.	cwt.	cwt.	cwt.	cwt.	tons	cwt.	qr.	lb.	tons	cwt.	qr.	lb.
1	—	—	—	—	—	—	17	1	2	8	4	10	2	8
2	4	3	1	1	—	—	21	6	1	4	4	2	2	8
3	—	3	1	1	—	—	19	1	1	4	5	9	0	0
4	—	3	2	2	—	10	23	19	2	8	5	16	1	4
5	4	3	2	2	—	—	24	14	1	20	4	14	1	4
6	—	3	2	2	—	—	20	17	2	8	4	15	0	16
7	—	3	1	1	—	10	24	11	1	4	5	3	0	0
8	4	—	1	1	1	—	23	5	1	4	4	7	3	12
9	—	—	—	—	—	—	16	5	0	16	4	17	2	24

The soil is a deep, rich, and friable loam upon white sand.

These experiments were in exact repetition of several previous ones, with the object, amongst others, of showing the value, if any, of superphosphate for mangel, and the relative advantages of common salt and muriate of potash. In the present instance, and for the first time in the history of the Norfolk experiments, the effects of the superphosphate were clearly beneficial. And contrary also to, at any rate, some former experience, the potash proved itself more useful than the common salt. The most economical manure, for the land and season, was a mixture of 4 cwt. superphosphate, 1 cwt. muriate of potash, and 2 cwt. of nitrate of soda, at a cost of about 40s. per acre.

Further experiments carried out at Bolwick in 1890 on another field, again showed a gain from the use of superphosphate for the mangel crop. The Bolwick soil, however, as noticed in other experiments, appears to be deficient in phosphates, and the question is still open whether the beneficial effect of superphosphate shown here would be found in other parts of Norfolk. The earlier experiments of the Chamber pointed to the reverse.

*Salt Experiments upon Barley.*

These experiments were tried in 1890 at Bolwick and at Whitlingham ; the land had in each case been half-folded with sheep. The results were :—

PRODUCE OF BARLEY PER ACRE, 1890.

Locality	Plot	Manure per acre	Head-corn	Straw
Bolwick . . . {	1	3 cwt. fish salt . . .	bushels 46·09	cwt. qr. lb. 25 3 26
	2	No salt . . . . .	51·71	30 3 11
Whitlingham . {	1	3 cwt. fish salt . . .	52·81	35 1 22
	2	No salt . . . . .	49·37	32 2 10

These results point to no definite conclusion. At Bolwick the corn was much more laid on the salt plot than on that without salt. At Whitlingham rather more produce came from the salt plot, and neither crop was laid much.

Experiments on permanent grass-land, begun some seasons past, continued to show in 1889 and 1890 annual deterioration from continuous mowing, and the uselessness of artificial manures to prevent this. Farmyard manure and folding of sheep gave decidedly the more satisfactory results.

The Report of the Norfolk Chamber contains the record of several other field experiments carried out during the two years, and, in addition, that of the sheep-feeding experiments, which are of much utility, and are therein set out in full detail.

J. AUGUSTUS VOELCKER.

REPORTS OF THE CONSULTING  
ENTOMOLOGIST.

MAY 5, 1891.

SINCE my report of March 3 (page 168) the usual amount of application has been made regarding farm insect pests, but far more than has ever occurred before respecting various kinds of insects seriously injurious in fruit growing. About 400 applications for my Paris Green pamphlet have been received, and as in many cases a

written reply as to points of orchard insect prevention was also needed, the correspondence has been unusually large.

The crop attacks reported have been of the common kinds, as of daddy-long-legs grubs, wheat-bulb-maggot, turnip-gall-maggot, wireworms, clover-weevil-maggot, and the like, but rarely to a serious extent, excepting with regard to wheat-bulb-maggot and clover stem sickness, which may need a word.

This clover attack may be known (without any microscopic examination for the eel-worms which give rise to it) by the deformed growth of the infested plants. Many of the shoots will be found to be short, swollen, and with their side shoots placed almost close together as large swollen buds, or deformed in many other ways, and often decaying away below at ground level. The best remedy for this attack is a dressing of sulphate of potash



FIG. 1.—Wheat-bulb fly (*Hylemyia coarctata*) magnified, and lines showing nat. size; maggots and chrysalids, nat. size and mag.; mouth apparatus, and extremity of tail, with tubercles, mag.; infested plant.

3 cwt., with sulphate of ammonia 1 cwt., per acre. This has been found (especially in experiments at Rothamsted) to answer excellently both in stopping attack and in giving a vigorous growth, the good effects continuing to the second crop.

Where experimental clover plots have been destroyed by "stem sickness," clover succeeding on the same ground will be extremely likely to be attacked, unless the ground is properly trenched. Common digging, or even double digging, is not to be trusted to, as thus the surface soil infested by eel-worms, and pieces of infested shoot, are left near the surface to communicate the attack to the next crop.

Wheat-bulb-maggot is now appearing to a serious extent in various places, and it is very much to be wished that some experiments could be undertaken as to its prevention, for it is the cause of much loss almost yearly. The little yellowish maggot feeds

in the stalk or so-called bulb of the young wheat, and so destroys the infested shoot, and then turns to a chrysalis, from which the greyish two-winged fly comes out in a few weeks. At present (unless by a good stimulating dressing the side shoots and the plants not attacked can be pushed on so as to give some return), we know of no means of lessening the heavy loss that occurs where this bulb-maggot gains possession.

The attacks of willow-beetle have for some years caused so much damage that I am now in correspondence, and also if possible will have personal consultation, with a leading grower as to measures which are reasonably practicable for clearing the pests on a broad scale.

Inquiry has also been sent on the disputed question as to whether moles were doing good or harm. I therefore suggested in a case where they were in very great numbers, and running surface burrows in corn land, that a dozen should be caught, and examination made as to what they were feeding on. If this proved to be wireworms or grubs injurious to the crop, it would probably be best to leave the moles alone, otherwise it would be well to lessen their excessive numbers.

The great attention that has been bestowed on prevention of orchard moth caterpillars is proving of further service by drawing observation to various other kinds of orchard infestation, which, from inquiries sent me, appear to be less generally known about, excepting by skilled and trained growers, than could be thought possible.

One point is a confusion of the little reddish bark mites, or acari, and their bright red eggs, with the "red spider," so well known as infesting leafage, especially of hops and wall-fruit trees. As this misunderstanding draws off attention from measures to check the really serious infestations, it is perhaps as well to mention it.

Another attack, less understood than it should be, regarding which inquiry is sent, is that of the woolly aphid, commonly known as "American blight." This is easily recognised (Fig. 2) by the white woolly patches, or even long tufts of white cotton-wool-like matter, noticeable where the aphides congregate, and also by the diseased knots on young shoots, and large, cankered, swollen and cracked masses on older parts of infested trees. The attack may be easily kept down by syringing and rubbing soft soap or some kind of soft soap wash (or any other of a great number of applications which will stifle the aphides) on to the infested trees, or into the cracked and infested places. Also, as far as may be, pruning off infested shoots, and smoothing down the large masses of cankered growth, so that there may be no sheltering places for attack.

The black-currant gall mite (Fig. 3) has become a serious and widespread trouble in bush-fruit farming. This *Phytoptus ribis* is a microscopic mite, which causes the black-currant buds, instead of developing properly, to swell into mere small green abortive knobs. On opening these lately I have found not only the minute cylindrical

four-legged mite, but also that the eggs were plentifully present, which shows the desirableness of breaking these buds off and

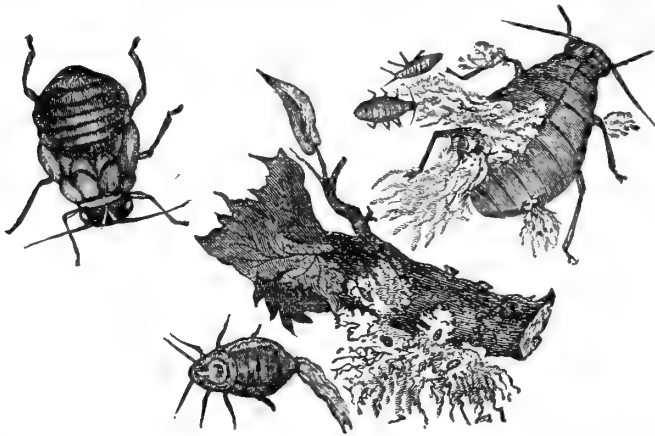

FIG. 2.—Woolly aphid; infested apple spray, nat. size; wingless viviparous female and young clothed with cottony fibres, *above*, and small egg-bearing female, *beneath*, the spray; pupa, with slight cottony growth; all magnified.

destroying them. Cutting back the infested shoots, and burning them, of course checks spread of attack, but in this case there is the

loss of the whole crop of the shoot, instead of merely that from abortion of a part of the buds. The best application which has been reported is that of a soft soap and sulphur wash. This may be allowed to run down, and thus choke infested nooks. This attack is one needing special observation, for it is very injurious, and very difficult to meet. From examination of specimens lately sent me, I think, however, that a dipterous parasitic larva (that is to say, the maggot of a two-winged fly) is doing good service by feeding on the mites.

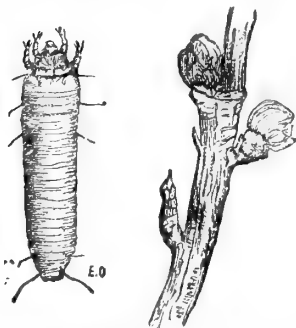

FIG. 3.—Phytoptus (? species) enormously mag. Infested black currant buds.

Very great interest is taken in many parts of the country in the treatment for destroying orchard moth caterpillars by spraying with Paris Green, and the Evesham Fruit Experimental Committee are continuing to bestow very careful attention upon methods of working, the most serviceable kinds of spraying implements, and other details. I am myself assisting, so far as lies in my power, both personally and by reference to official entomologists in the United States and Canada.

The only point in which we differ from the latter is that, whereas in America the plum leafage is found to be more easily injured by



spraying than the apple, here the reverse is the case. We find that, while we do not advise more than 1 oz. of Paris Green in 20 gallons of water for apple leafage, the plum leafage will usually bear a mixture of 1 oz. in 10 gallons. This strength, Dr. Lintner writes me, would, in the United States, "bring every leaf off the plums;" but whether the difference is from climatic influence or from difference in kind of plum we have not yet made out.

We are continuing to find the benefit of last year's treatment. I have reports, from various places where the Paris Green spraying was used on a large scale, of winter-moth caterpillars (up to date of report) being comparatively absent, whilst over a district where (so far as I am aware) little or nothing was done in this way I have report of the caterpillars appearing in large numbers. In all my communications I have been careful to point out that the experiments were simply directed to checking the ravages of moth caterpillars, or insects which bite and swallow the leafage, and (on the face of the thing) that the treatment did not appear likely to get rid of the kinds of infestations which, like aphides, feed by piercing down through the outer tissues and drawing up sap from below. Nevertheless, I have a trustworthy instance sent me in which aphid attack was cleared by this spraying, so that, though I would not on any account advise its trial on hops, it may be worth while to experiment more extensively.

A great improvement has been made in the manufacture of Paris Green by grinding it much finer, consequently on which it does not deposit so much as before when mixed with water; also it can be procured damp (as a paste), by which means much of the difficulty of mixing the dry powder, and inconveniences from the powder flying about in mixing, are avoided.

Amongst other insecticides, I am giving attention to a mixture of soft soap and sulphur, made very nearly on a recipe which has been found serviceable in South Australia, and recommended by the late Mr. Frazer Crawford (the Government Inspector under the Vine, Fruit, and Vegetables Protection Act) in his report, printed by direction of the Hon. the Commissioner of the Crown Lands. This Australian mixture has been found especially serviceable against such attacks as aphid and mildew together, with red spider, gall mites, &c., and likewise against moth caterpillars harbouring in bark. I have so very often to recommend the use of soft soap and sulphur washes as a preventive for insect attacks of various kinds, that, if this mixture answers as well on continued experiment as seems likely at present, it may save much trouble to be able to purchase it.

Inquiry has been sent me, and also I have been in correspondence with firms in various parts of the country, as to the desirability of issuing a mixture (or emulsion, as it is called) of soft soap and Paris Green. I do not advocate this, partly because, so far as I am aware, we have no precedents on acknowledged authority as to the effects of the mixture according to any given recipe; partly because, the strength of Paris Green in the mixture being possibly

variable, much mischief to foliage might ensue ; and also partly because, from chemical changes which would or might arise, the aceto-arsenite or Paris Green might become another form of copper, and the name of " Paris Green Emulsion " be not accurate.

What the effects might be I cannot say, but in my own recommendations I limit myself entirely to the use of Paris Green simply mixed with water, or with the addition of a little flour, in the way of which we have many years' record as safe and serviceable.

In the apparatus for distribution of insecticides we are improving almost from week to week. With regard to large and expensive spraying machines, these are sufficiently before the public, but for a convenient form where there is no room for wheeled apparatus we still find the knapsack known as L'Éclair (figured on page 232) answer excellently. It throws a good spray to the height of about fifteen feet, and by a very simple adaptation arranged by a co-operator of our Evesham Committee, and which each operator could make for himself, the spray can be given an additional elevation, throwing it up to twenty or twenty-five feet. I am now in correspondence as to having the sprayers adapted by the manufacturers to give this greater height.

As it is a great object to avoid extra expense, I may mention that for greater heights we are finding that an ordinary garden engine will answer perfectly well with the outlay of a few shillings. A water-barrel on two wheels with sufficient pumping force (something of the nature of the kind known as the Farringdon Hop and Plant Washer) answers well, with the form of sprayer known as " Stott's " nozzle, attached by a piece of hose and a tap union. By this apparatus a fine spray can be thrown to a height of forty feet, and implements often at hand may be made available without special outlay.

One more point is still greatly needing attention, namely, warble extirpation. The great losses by this attack are constantly urged on me, and I am doing all I can ; but, unlike the orchard work, the carrying out of operations rests not with well-instructed owners, but in many cases with those who are wholly ignorant, and very careless, so that something to meet this difficulty is greatly needed.

JUNE 2, 1891.

Since my report of the 5th of May, applications have been sent, as usual, regarding various kinds of crop and orchard insect attacks, but for the most part these do not need special mention now. But amongst them, that of the wheat-bulb maggot, the larva of the *Hylemyia coarctata*, has once again been doing such serious mischief that I have been endeavouring to collect all the information I could about it, and now beg to submit a special report on the subject.

I have received reports of the infestation being present at various localities in Essex and Cambridgeshire, also round Bedford, at Hertford, near Alford in Lincolnshire, near Dalton-on-Tees, and in the district near Gloucester, and also near Tewkesbury.

From Southminster, in Essex, the attack was reported as worse than ever this year, many of the wheats being so bad that they had to be ploughed up in some cases, and patched with oats in many others ; and another note from Essex about the beginning of May mentioned that what had been a full plant in the field attacked a month before had then wasted down 50 per cent. in the infested part, and was still going. From near Tewkesbury (to take a return from the other side of the country) a correspondent who has watched the attack for many years writes me that he does not ever remember it so extensive as it is this season, and that he estimated the loss on the clay-land fallow wheat at nearly one-half. Reports from other localities also confirm these observations, and those of previous years, regarding the great loss caused by the maggot in the young wheat plant.

This attack appears to be steadily becoming more prevalent. It was first regularly reported as a crop pest (though obviously present before) in 1881, and in 1882 I reared the fly, so that we were able to identify the infestation, but no further special notice of it occurred until 1886. Since then we have had it in 1888-89-90, and now again this year, and the attacks of 1888 and the present season have both been bad.

The injury, as previously mentioned, is caused by a small maggot, which feeds in the heart of the young wheat. This may be observed beginning to affect the plant by the first days of April, or earlier. The maggots change to the chrysalis state in or by the destroyed shoots in May, or early in June, and the fly comes out, in this country, as far as I have seen at present, at the end of June, or the beginning of July. It is a little black and grey two-winged fly, not at all unlike the common onion fly.

The reports given this season confirm the previous observations, that the attack is mainly or often found after fallow, or on fields, or portions of fields, where the surface has been exposed during the preceding summer, as where patches of turnips have failed, potato leafage been thin over the ground, or the crop dug early ; or, again, where clover has failed ; and a special observation was sent of where oat crop was cut very close to the ground (during a spell of hot weather last summer), the infestation of the bulb maggot afterwards following the line to which the close crop extended almost to an inch.

The infestation may occur after many kinds of crops, but from collation of the great number of observations which have been sent me, it appears to me that its presence is very much influenced by the state of the surface of the land, and likewise by the method and date of the mechanical operations of cultivation of the surface of the land, respectively in the summer, before or the time immediately before the date of sowing.

Observations have been sent of the headlands not being attacked, even to the difference showing as of a framing like that of a picture of the vigorous wheat round the attacked crop. In one instance it was noted that the saved headlands had been worked hard by the

trampling of the horses. Also in another instance (at Dalton-on-Tees) it was reported to me on special inquiry, that in a field so badly attacked that the wheat was gone altogether in some places, yet the "head riggs" which had been trampled escaped attack entirely.

The fact of open land favouring prevalence of attack is also pointed to by greater infestation having been found where the soil was hollow at the top of the ridges, by reason of the plough throwing the slices together from opposite directions. Notes have also been sent of land stirred by ploughing, scarifying, &c., in September and October, having the infestation, whilst contiguous land not worked quiet escaped.

From inquiries in one district, I found that some fifty years ago it was the regular custom to roll fallow land after it was sown with wheat in the autumn, to prevent it being turned out by the frost. The loosening by frost is of course well known; but on examination being made in many fields of this district that were now said to be "turned out," it was found that in every instance it was the wheat-bulb maggot, and not the frost, that had done the mischief. This observation seems worth attention in connection with the others about "firmed" soils, and, my reports being from well-known correspondents, all details would be easily procurable.

Date of autumn sowing appears not to affect attack. I have notes of maggot presence after sowing in October, November, December, and January, and of a December sown crop being totally destroyed, but I have no notes of the infestations having been found on spring-sown wheat, nor, on special inquiry, have I been able to find that it has been observed. This is a point which it would be useful to have precise information about.

Rank manures appear to increase the virulence of the attack. I have notes of wheat after turnips manured with fish, and also after cabbages manured with sprats and fed off by sheep, having to be ploughed up, or being destroyed, and the attack is repeatedly mentioned as following feeding off by sheep. Also where pond mud was used as a fertiliser the attack was very severe, the area precisely corresponding with the portion of the field where the mud dressing had been thrown. Some chemical manures, however, appear possibly to do good. In one case of attack after dead fallow on the greater part of a field, two portions of which had been in mangel, a dressing of ten cwt. of superphosphate of lime to the acre gave a vigorous wheat crop, with no signs of maggot.

I had hoped that we might have discovered locality of summer brood in wild grasses, and especially in couch grass, but three years' careful observations of a scientific correspondent have failed to show presence of the pest in any grasses in ordinarily accessible localities.

Therefore (so far as I am aware) we do not even know whether there is a summer brood, and consequently we do not know whether the autumn and winter attack is started by egg-laying of what may be called the old flies, which have lived on from the middle of the

summer, or of fresh flies from a summer brood of which we do not yet know the locality—or (which observations so far seem to me most to point to) from eggs laid in the land, the maggots from which, in due season, attack the autumn and winter-sown corn.

Further observations are very much needed to give some basis for generally practicable measures of prevention, as at present this attack is a cause of great loss, more especially in the Eastern Counties, not only to the extent of damaging the young wheat often to the necessity of ploughing in or patching, but also, as shown by the notes with which I was favoured for publication (see p. 51 of my 14th Report) by Mr. Michael Ellison, of Barber Woodhouse, near Rotherham, is liable both to lessen the yield on attacked plants which have survived to maturity, and likewise very much to lessen the quality of the grain.

I should be glad to give any information in my power to any applicant, and also to receive any, with a view to forming a more complete report. Amongst the various points, anything bearing on the preceding condition of the land as to cropping or fallowing, and particularly any details regarding surface treatment (as harrowing or scarifying, or rolling and trampling), would be desirable.

Amongst other crop attacks, inquiries have been sent regarding the turnip-seed weevil (*Ceutorhynchus assimilis*) and the blossom beetle (*Meligethes aeneus*), both of which are doing mischief. In the latter case not only flowers of the cabbage tribe, but apple-blossom buds also were found infested by the little dark-greenish beetles. In this case, however, where the trees are only of a moderate height, something may be done to lessen attack, at least in garden treatment, by jarring the branches, so as to cause the beetles to fall on tarred cloths or boards laid below.

Serious injury has been caused in raspberry plantations by a small red caterpillar, agreeing both in appearance and habits with that of the raspberry moth, the *Lampronia rubiella*. This turns to chrysalis in the bud within which it has fed, or close to it, as in the shrivelled young leaves around. It is now turning, or has lately turned, to chrysalis state, and no time should be lost in breaking off and destroying all infested buds or shoots. Where this has been already done, as it has very carefully on some plantations, the attack next year may be expected to be much lessened.

Since writing the above, the first of my own specimens developed on June 1, from the chrysalis, and agreed in every respect observable with the description of *Lampronia rubiella*. This is a small moth, somewhat about the size of a clothes moth, with the upper wings brownish, spotted with yellow, two of the spots on the inner margin of the wing much larger than the others, and four on the outer margin large enough to be noticeable, the others much smaller, the under wings fuscous, the head yellowish, face somewhat greyer.

I have received an application from the Secretary of the Falkland Islands Company regarding some kind of fly which is considered to have been recently imported into the Islands, and is proving very

injurious to meat. As this matter is of considerable importance, I am doing what I can about it. I have asked for specimens to be sent over, and also for information what the cargo of the ship was in which the infestation was supposed to be brought, and where it came from.

Meanwhile, I have suggested a very simple arrangement, which I know answers excellently out of doors, for attracting many kinds of flies, which they do not escape from, and so without trouble are destroyed; and also one or two other arrangements which might be expected to be of use, especially that all waste and rubbish at the butcher's should be collected at short intervals, and so treated that the maggots should be destroyed. This seems all that can be done at present; when specimens and information arrive I will duly attend to them.

ELEANOR A. ORMBROD.

## QUARTERLY REPORT OF THE CHEMICAL COMMITTEE.

JUNE, 1891.

THE following five cases have reference to purchases of linseed-cakes which were sold with a guarantee of purity, but were found on examination to be impure.

They exemplify the uselessness of such a guarantee as "95 per cent.," or "made from linseed of 95 per cent. purity" (expressions which can only be properly applied to the seed, and not to the manufactured cake), and, indeed, of any guarantee other than that of "pure linseed-cake."

1. Mr. Silvanus Brown, of Slipton, Thrapston, Northampton, sent for analysis on February 3, 1891, a sample of linseed-cake. The following report was returned to him on February 7:—

Moisture . . . . .	12·04	} 100·00
Oil . . . . .	8·33	
<sup>1</sup> Albuminous compounds (flesh-forming matters) . . . . .	25·37	
Mucilage, sugar, and digestible fibre . . . . .	34·69	
Woody fibre (cellulose) . . . . .	8·56	
<sup>2</sup> Mineral matter (ash) . . . . .	11·01	
<sup>1</sup> Containing nitrogen . . . . .	4·06	
<sup>2</sup> Including sand . . . . .	5·50	

This cake has a considerable amount of sand in it. This ought not to exist. The quality is low.

A second sample, sent on March 3 by Mr. Brown from the same

delivery, was found to contain 3.10 per cent. of sand. A five-ton lot had been purchased on a basis of "95 per cent. purity."

In reply to inquiries for further particulars, Mr. Brown wrote that the merchant was a young man of business, and he would be sorry to cause him any injury, but he had come to the conclusion not to purchase anything of him in future.

2. Mr. G. C. Robertson, of Widmerpool, Nottingham, forwarded for analysis on March 31, 1891, a sample of linseed-cake of which two tons had been purchased from Messrs. Wright Bros. & Co., of Hull (who are also the manufacturers), at 8*l.* per ton, carriage paid. The order ran as follows:—

"Messrs. Wright—Two tons, Pure, 95 per cent. Linseed-cake."

The words on the invoice were:—

"Two tons 95 per cent. Linseed-cakes @ 8*l.* = 16*l.*"

The report on this sample was:—

		April 6, 1891.
Moisture . . . . .		11.80
Oil . . . . .		10.65
<sup>1</sup> Albuminous compounds (flesh-forming matters) . . . . .		27.56
Mucilage, sugar, and digestible fibre . . . . .		36.14
Woody fibre (cellulose) . . . . .		7.25
<sup>2</sup> Mineral matter (ash) . . . . .		6.60
		} 100.00
<sup>1</sup> Containing nitrogen . . . . .		4.41
<sup>2</sup> Including sand . . . . .		1.45

The cake is not pure; it has a considerable amount of foreign seeds, among which *spurry* and *platykop* are most prominent, and *rape* is there also. The cake is made from seed not properly cleaned.

Upon Mr. Robertson complaining, the following reply was received from the vendors:—

G. C. Robertson, Esq.,  
Widmerpool, Nottingham.

April 24, 1891.

SIR,—We thank you for your favour of 22nd inst., with extract from a report of Dr. Voelcker on the cake we last sent you. The linseed we use for our 95 per cent. cakes (for we suppose you refer to the linseed cakes) is bought with a guarantee that it shall contain not less than 95 per cent. of pure linseed, according to the London Linseed Association's certificate of analysis of samples taken during discharge here by independent parties. If, *as is the fact*, our cakes are made solely of such seed, we fully comply with the guarantee we give; not, indeed, of *absolute* purity, which is well-nigh impossible, but of a percentage of 95 of purity, which is considered by practical men all that is reasonable. It is therefore immaterial to us what Dr. Voelcker may allege to the contrary, except that such reports are calculated to cause prejudice in the minds of consumers, though, at the same time, they no doubt suggest (perhaps unintentionally) the need there is that the watchfulness of the agricultural chemists should never be relaxed





hurst, and the manufacturers, Messrs. Brook & Co., Tovil Oil Mills, Maidstone. The report on this cake was as follows :—

April 20, 1891.	
Moisture . . . . .	11·35
Oil . . . . .	13·16
<sup>1</sup> Albuminous compounds (flesh-forming matters) . . . . .	26·18
Mucilage, sugar, and digestible fibre . . . . .	31·83
Woody fibre (cellulose) . . . . .	10·73
<sup>2</sup> Mineral matter (ash) . . . . .	6·75
} 100·00	
<sup>1</sup> Containing nitrogen . . . . .	4·19
<sup>2</sup> Including sand . . . . .	1·90

The cake is not properly free from impurities, such as *rape-seed*, *earth-nut*, &c., and has high fibre and too much sand.

In correspondence it was elicited that the cake was guaranteed to the vendor as being made only of the best Calcutta linseed, bought on a basis of 96 per cent. purity.

5. Capt. J. H. Burstall, of Hessle Mount, Hull, sent on April 20, a sample of linseed-cake. The following report was given :—

April 24, 1891.	
Moisture . . . . .	12·05
Oil . . . . .	11·66
<sup>1</sup> Albuminous compounds (flesh-forming matters) . . . . .	28·31
Mucilage, sugar, and digestible fibre . . . . .	31·65
Woody fibre (cellulose) . . . . .	7·73
<sup>2</sup> Mineral matter (ash) . . . . .	8·60
} 100·00	
<sup>1</sup> Containing nitrogen . . . . .	4·53
<sup>2</sup> Including sand . . . . .	3·45

The cake is an impure one, containing a considerable quantity of weed-seeds, chiefly *spurry*, and  $3\frac{1}{2}$  per cent. of sand.

In reply to inquiries Capt. Burstall said :—

May 8, 1891.

DEAR SIR,—As one of the firm from whom I bought the linseed cake is a personal friend I don't wish to take any further steps. It was sold as 95 per cent., but not pure.—Yours faithfully,

J. H. BURSTALL.

The following case shows the danger of purchasing without a guarantee of any kind.

6. Mr. William Lester, of Espley Farm, Hodnet, Salop, sent on March 10, 1891, a sample which was invoiced to him as linseed-cake. The following report was returned :—

March 18, 1891.

Moisture . . . . .	13·75	} 100·00
Oil . . . . .	13·90	
<sup>1</sup> Albuminous compounds (flesh-forming matters) . . . . .	25·12	
Mucilage, sugar, and digestible fibre . . . . .	26·65	
Woody fibre (cellulose) . . . . .	8·13	
<sup>2</sup> Mineral matter (ash) . . . . .	12·45	
<sup>1</sup> Containing nitrogen . . . . .	4·02	
<sup>2</sup> Including sand . . . . .	5·75	

The cake is an impure one, containing, besides starchy ingredients in some quantity and also *rape*, nearly 6 per cent. of sand, which is highly objectionable.

Upon being pressed for information Mr. Lester wrote :—“The agent has made a very considerable allowance on this cake. I had no guarantee as to the purity of it, so I do not wish any further steps taken in the matter.”

The following cases refer to dissolved bones.

7. Capt. H. Heaton, of Stetchworth Park, near Newmarket, agent to Lord Ellesmere, sent on April 27, a sample of what had been described to him as “pure Dissolved Bones.” On this the following report was given :—

April 30, 1891.

Moisture . . . . .	9·21	} 100·00
<sup>1</sup> Organic matter and water of combination . . . . .	19·89	
Monobasic phosphate of lime . . . . .	18·93	
Equal to tribasic phosphate of lime (bone phosphate) rendered soluble by acid	(29·64)	
Insoluble phosphates . . . . .	11·46	
Sulphate of lime, alkaline salts, &c. . . . .	37·74	
Insoluble silicious matter . . . . .	2·77	
<sup>1</sup> Containing nitrogen . . . . .	2·04	
Equal to ammonia . . . . .	2·48	

This is not made altogether from *raw* bone and acid only, although it is a good manure.

Twenty tons of this had been purchased at 7*l.* per ton less 5 per cent. delivered.

The manufacturers in their circular described two different articles under the name of “pure Dissolved Bones,” viz. :—

No. 4.—*Pure Dissolved Bones.*—Made of steamed and raw bones dissolved with sulphuric acid.

No. 4a.—*Pure Dissolved Bones.*—An exceptionally high-class article, made of raw bone meal only, dissolved with sulphuric acid, by a method recently discovered by us, which enables us to produce a dry and finely pulverised article without the use of any “drier.”

It is understood in the trade that “pure Dissolved Bones” shall consist of *raw* bones and acid only, and the term ought

not to be applied, as in the case under notice, to a mixture of "steamed and raw bones dissolved with sulphuric acid."

It is desirable to put purchasers on their guard in respect to this.

8. A large farmer in the West of England purchased, direct from the manufacturers, 35 tons of "Dissolved-bone Manure," upon the basis of a contract under which the firm in question supplied a Farmers' Club in the neighbourhood, and which contract read as follows :—

The dissolved bone to be derived from raw bones ground before being dissolved, must contain not less than 24 per cent. of soluble phosphate, 8 per cent. of insoluble phosphate, and 1 per cent. of ammonia.

The invoice, however, simply read as follows :—

Dissolved Bone Manure	{	1 per cent. ammonia.
		24 per cent. soluble phosphates.
		8 per cent. insoluble phosphates.

The following report was sent upon the sample forwarded for analysis :—

February 14, 1891.

Moisture . . . . .	15.57	} 100.00
<sup>1</sup> Organic matter and water of combination . . . . .	15.69	
Monobasic phosphate of lime . . . . .	14.50	
Equal to tribasic phosphate of lime (bone phosphate) rendered soluble by acid	(22.70)	
Insoluble phosphates . . . . .	12.98	
Sulphate of lime, alkaline salts, &c. . . . .	35.65	
Insoluble silicious matter . . . . .	5.61	
<sup>1</sup> Containing nitrogen . . . . .	0.83	
Equal to ammonia . . . . .	1.01	

Though coming nearly up to the figures of the guarantee, this sample is not what you state in your letter it should be, viz., "wholly derived from bones." It contains other phosphate than obtained by dissolving pure bones.

A long correspondence ensued, the purchaser claiming that he had a right to expect "pure dissolved bones," and nothing else, the vendors, on the other hand, contending that they had complied with the guarantee and that the interpretation to be put on the clause of the contract was, that ground raw bones must be used in the manufacture of the manure, and that only the ammonia need be derived from the raw bones.

They pointed out further that the analysis of a sample made from raw bones and acid only would not work out to the figures contained in the guarantee, and further, that such a manure could not be sold at anything like the price they quoted.

The vendors in a letter said :—

The interpretation we put on this clause is that ground raw bones must be used in the manufacture of the manure, which has been done; if,

however, as one might infer from Dr. Voelcker's report, that bones and nothing else should have been dissolved, we at once confess that such has not been the case, neither can we admit that the contract is entitled to this construction, as the analysis required makes this impossible. We quite admit that the clause in question is open to almost any construction.

In reference to this case it is desirable to point out the necessity of caution in framing contracts, and of insisting upon the insertion upon the invoice of the words "pure Dissolved Bones;" for, though the statements of the manufacturers were perfectly correct, the manure was not one which could be said to properly conform to the description given in the form of contract.

The following case is an instance of low-class superphosphate being supplied:—

9. Mr. F. Reynard, of Sunderlandwick, Driffield, sent on April 21 a sample of superphosphate, 27 tons of which had been purchased from an agent of a manure company, it being guaranteed to yield 26 per cent. of soluble phosphate.

On analysis the sample proved to have only 16.59 per cent. of soluble phosphate.

Mr. Reynard, not having used any, obliged the vendors to take it back at their own expense.

The three remaining cases refer to more or less worthless feeding stuffs and manures.

10. Mr. R. Neville-Grenville, of Butleigh Court, Glastonbury, sent on March 21 a sample of so-called "Improving Meal."

On this the following report was given:—

	April 2, 1891.
Water of combination . . . . .	20.70
Sulphate of lime . . . . .	78.20
Matter insoluble in acid, &c. . . . .	1.10
	} 100.00

This "Improving Meal," as it is called, is very fine sulphate of lime (gypsum). As you can get any quantity of gypsum for about 1*l.* a ton, this "meal" at 4*l.* 15*s.* per ton would be excessively dear, even supposing it to have any feeding value, which it has not.

The meal had been offered to a local miller by the vendors, Messrs. James Arkell & Co., Gloucester, in accordance with the following letter:—

Gloucester: March 7, 1891.

DEAR SIR,—We are in receipt of yours, and have the pleasure of handing sample of our Improving Meal, price 4*l.* 15*s.* per ton at your station, in bags lent free until emptied, for lots of two tons and upwards. We only supply one miller in a district, and have not sent any into yours, so shall be pleased to supply you only there.

With the certainty of present high prices of barley, maize, &c., continuing,

you would find this a most serviceable article; some of our customers express regret at not having had the opportunity of using it before, and would not now be without any. Your order will be esteemed.—Truly,  
 JAMES ARKELL & Co.

11. Mr. J. Redman, of Winterbourne, Swindon, sent on March 21 a sample of meal for analysis, saying that it was "Oat Sharps" and was offered to him at about 4*l.* per ton.

The following was the report on the material :—

		April 6, 1891.
Moisture	. . . . .	10.38
Oil	. . . . .	0.33
<sup>1</sup> Albuminous compounds (flesh-forming matters)	. . . . .	0.69
Mucilage, sugar, and digestible fibre	. . . . .	54.81
Woody fibre (cellulose)	. . . . .	30.40
<sup>2</sup> Mineral matter (ash)	. . . . .	3.39
		} 100.00
<sup>1</sup> Containing nitrogen	. . . . .	0.11
<sup>2</sup> Including sand	. . . . .	2.84

This is nothing more than oat husks, and is almost entirely fibrous material, having but little feeding value. The price asked for it is altogether absurd, and I would not advise you to use it.

Mr. Redman did not purchase any of the meal.

12. Mr. J. C. Buckwell, of 3 New Road, Brighton, sent for examination on February 26 a sample of manure which was sold to him as "Silicate Manure," for vines. He had purchased two tons, the price being 7*l.* per ton; the vendors were the Patent Silicate Manure Co., Chemical Works, Hemel Hempstead, Herts. The following was the analysis returned :—

		April 10, 1891.
Moisture	. . . . .	4.95
<sup>1</sup> Organic matter	. . . . .	5.79
Sulphate of lime	. . . . .	22.95
Oxide of iron, &c.	. . . . .	2.30
Insoluble silicious matter	. . . . .	64.01
		} 100.00
<sup>1</sup> Containing nitrogen	. . . . .	0.89
Equal to ammonia	. . . . .	1.08

This is little more than sand and sulphate of lime. It is scandalous to charge such a price as 7*l.* a ton for a material like this.

Mr. Buckwell said that it was supposed to contain a very large proportion of soluble silicates, and was strongly recommended for vines. On examining the sample, Dr. Voelcker found that the manure contained no soluble silicates at all, and wrote to Mr. Buckwell as follows :—

To my report I may add that I have tested the manure carefully, and it contains practically no soluble silicates at all, and the availability is just about equal to that of *ground flints*, which, indeed, the manure sent by you virtually is, together with some sulphate of lime and a little organic matter.

Whether 7*l.* a ton is a fair price for such a material or not I think my report to you has clearly indicated.

The circular sent by the company contained testimonials from the gardeners to the following noblemen :—Lord de Ramsey, Earl De la Warr, Marquis of Hartington, Duke of Hamilton and Brandon K.T., Lord Middleton, Earl of Radnor, Earl of Carnarvon, Lord Northbourne, Marquis Conyngham, Duke of Rutland, Lord Stafford, Earl of Effingham.

The following report was also contained in the circular :—

#### REPORT ON MR. PIFFARD'S PATENT SILICATE MANURE.

Chemical Laboratory, 54 Holborn Viaduct, London :  
September 1, 1888.

We have analysed a sample of the Silicate Manure invented by Mr. Bernard Piffard, of Hill House, Hemel Hempstead. We find, as the result, that this manure contains a very large proportion of silicic acid, much of which is, no doubt, in a form capable of ready assimilation by vegetation.

The absolute necessity of a supply of silicic acid to cereals in particular is well known. In this invention we have an ingenious endeavour to adapt natural methods of conveying silicic acid in a suitable form to plants.

We are of opinion that this invention is based upon sound principles, and it is very probable that the idea which guided Mr. Piffard in the preparation of his Silicate Manure has led him to conclusions which will prove of considerable importance to agriculturists generally.

(Signed) ARTHUR HILL HASSALL, M.D. Lond.  
EDWIN GODWIN CLAYTON, F.C.S., F.I.C.

On Mr. Buckwell inquiring what the particular virtue of the manure consisted in, he received the following letter from the manufacturers :—

#### THE PATENT SILICATE CO.

The Chemical Works, Hemel Hempstead, Herts :  
John C. Buckwell, Esq., Brighton. May 2, 1891.

DEAR SIR,—In reply to yours of May 1 we beg to thank you for your cheque and return receipt.

We are not surprised at Dr. Voelcker failing in his analysis to discover the cause of an unsurpassing success. We have made many attempts to get copies of the various analyses that have been made of our manure, but have hitherto only succeeded in one instance, namely, that of Professor Stein's, the Danish State Chemist : his was totally wrong.

If you would kindly forward us Dr. Voelcker's analysis we could better judge whether he had detected the ingredients that its virtue is due to.

As regards the "virtue" of the manure, that is detailed on the circulars and attended to by the most responsible persons.

And if Dr. Voelcker asks to what that virtue is due, we must respectfully decline informing him.

We have no objection to the Royal Agricultural analysing it, but we decline giving an explanation.

We trust you will make your experiments without prejudice.—We are,  
dear Sir, yours truly,  
B. PIFFARD, P. S. M. Co.

(Signed) R. A. WARREN, *Chairman.*

June 2, 1891.

## REPORT OF EDUCATION COMMITTEE ON THE RESULTS OF THE SENIOR EXAMINATION, 1891.

THE Committee have to report that twenty-one candidates entered, and thirteen actually competed, at the Society's Senior Examinations which took place from the 12th to the 16th of May last, and that of these thirteen competitors nine have satisfied the Examiners.

2. The following eight candidates, placed in order of merit, have gained first-class certificates with the Life Membership of the Society, the first four being entitled in addition to the prizes stated below :—

1. RAOJI BHAILÁL PATEL, Royal Agricultural College, Cirencester. *First Prize of 25l.*
2. EDRIC DRUCE, Royal Agricultural College, Cirencester. *Second Prize of 15l.*
3. JAMES GUNTER, Estate Office, Glasbury, Radnorshire. *Third Prize of 10l.*
4. JOSEPH LISTER, Agricultural College, Aspatria. *Fourth Prize of 5l.*
5. HENRY FREDERICK HILL, Agricultural College, Aspatria.
6. PERCY CHARLES BURTON, The Elms, Pontyclown, Glamorgan.
7. ERNEST ALLEN STAPLEDON, Royal Agricultural College, Cirencester.
8. HARRY AUSTIN LINDSAY YOUNG, Loseley House, West Horsley, Leatherhead.

3. The following candidate, having passed in Agriculture and in three of the four other compulsory subjects, is entitled to a second-class certificate :—

9. ROBERT JAMES IRVING, Blackhall House, Carlisle.

4. Of the compulsory subjects there were two failures in Agriculture, two in Chemistry, three in Book-keeping, one in Land Surveying. There were no failures in Agricultural Engineering. Of the optional subjects there were eight failures in Botany, one in Geology, four in Anatomy, and one in Agricultural Entomology.

5. The Examiner in Agriculture (Mr. T. H. Thursfield) reports that "the agricultural knowledge of the candidates had been gained in very varied localities, and knowing from previous experience the probability of this, and having found a difficulty in making proper allowance for it, the questions were set so as to be equally suited to all comers.

"Nearly the whole of the papers were satisfactory, and showed very considerable knowledge, even where the candidate had evidently not had the advantage of being practically engaged in Agriculture. The views expressed as to probable success in farming were varied, but not encouraging to those about to embark in it."

6. Only two candidates failed in Chemistry, whereas last year no less than eight, or half of the competitors, proved unable to pass in this subject. The Examiner in General Chemistry (Professor Liveing) makes no comments upon the Examination; but the Examiner in Agricultural Chemistry (Dr. J. Augustus Voelcker) remarks that "with one exception the papers have been very satisfactory indeed, and, considering the number of candidates, there has been a wonderful evenness of character throughout. All but one of the thirteen candidates obtained two-thirds or more of the marks obtainable; and one candidate lost only nine marks in the written and two marks in the *vis-à-voce* examination."

7. The Examiner in Book-keeping (Mr. C. Gay Roberts) points out that one candidate obtained full marks and observes that "most of the candidates succeeded fairly well in the journalising and posting, but in drawing out the Profit and Loss Account and the Balance Sheet many of them failed."

8. The Examiner in Mensuration and Land Surveying (the Rev. Professor Twisden) reports that "the first five questions [see page 414] were in many cases correctly answered, and for the most part in such a way as not to call for remark. In question 1, however, the answer was often found in Yards, though the form of the question seems to suggest Chains and Links. In question 2, when the first part has been answered, the second diameter might be seen to be four and a half times the first. The answer was found, in all but one instance, by a long independent process. Nearly all the solutions of question 5 depended on the prolongation of a short line. In question 6 the scale suggested is small, but this causes no difficulty in drawing the diagram, and I should have expected that all the candidates would have got so far as to make the plan; but this was by no means the case. In two or three instances, however, not only was the plan drawn, but a very good approximation to the area was also obtained in spite of the smallness of the scale. Question 7 was answered, on the whole, very well. There were, of course, several mistakes in the work of one and another; but in a good many instances the form was rightly completed, and the section correctly drawn. The calculation in question 8 proved to be beyond the powers of the candidates, as was the case with a similar question last year."

9. The Examiner in Agricultural Engineering (Dr. William Anderson) reports that, upon the whole, the work done this year is better than last. He says:—"The sketching and drawing is again bad, and points, I think, to a defect in the curriculum of the agricultural and science colleges, because no less than ten out of the thirteen candidates have had college training. The reason why I insist upon the importance of drawing is because I am persuaded that it is the best means of making the students acquainted with the details of mechanism of the implements which they will have to use and keep in repair. By way of illustration of my meaning I may mention that twelve candidates attempted question 16—'Sketch an ordinary cartwheel and describe its various parts.' The answers were poor in every case, and the state of knowledge is well illustrated by the



introduction to one of the answers, which was, 'I know what a cartwheel is, right enough, but I can't sketch it; it gets like a fly-wheel.' The questions which were dealt with in the most satisfactory manner were those connected with Physics or those in which some chemical knowledge was necessary. The information possessed by the students relating to the properties of ordinary building materials is poor and seems to indicate that very little instruction is given in this subject."

10. Of the optional subjects only four competitors out of twelve succeeded in satisfying the Examiner in Botany (Mr. W. Carruthers, F.R.S.), and the papers are characterised by him as "very poor, showing a want of accurate knowledge of Elementary Botany." The Examiners in Geology and Anatomy (Professor Rupert Jones and Professor Simonds) make no comments upon the quality of the papers submitted to them. The Examiner in Agricultural Entomology (Miss E. A. Ormerod) reports that, "as a whole, the candidates have very fairly correct views as to the effects of good cultivation in lessening damage from insect attack, and in some cases there are good replies as to prevention of Turnip Flea Beetle attack, and also treatment of grass and clover land before breaking up to clear wireworm. Warble attack they are also perfectly at home in the cure of. It is to be wished, however, that they were more perfectly acquainted with the distinctions between insects in their grub and caterpillar (*i.e.* larval) state, as this is important practically."

11. The general result of the Examination shows a very satisfactory proportion of successes, but more attention appears to be necessary to the subject of Botany.

12. The following Table gives the marks assigned by the Examiners to the work done by each candidate in the several subjects.

Name of Candidate	Age of Candidate	Agriculture, Paper, <i>max.</i> 200	Agriculture, <i>viva voce</i> , <i>max.</i> 100	Chemistry, <i>max.</i> 200.	Book-keeping, <i>max.</i> 200	Land Surveying, <i>max.</i> 200	Agri. Engineering, <i>max.</i> 200	a. Botany, <i>max.</i> 100	a. Geology, <i>max.</i> 100	a. Anatomy, <i>max.</i> 100	a. Agri. Entomology, <i>max.</i> 100	Total Marks
+	32	104	65	+	+	+	154	+	+	+	75	+
*Burton, P. C. . . . .	23	131	65	132	140	137	152	+	78	50	+	885
*Druce, E. . . . .	19	161	75	145	200	144	138	+	66	50	75	1,054
*Gunter, J. . . . .	31	158	85	110	105	100	148	52	83	60	90	991
*Hill, H. F. . . . .	27	124	80	119	120	129	170	+	71	55	100	968
†Irving, R. J. . . . .	21	125	50	153	+	131	167	51	86	70	100	933
*Lister, J. . . . .	15	123	65	116	115	142	125	51	76	70	100	983
+	41	143	60	+	+	104	150	+	80	+	60	+
*Patel, R. B. . . . .	25	137	70	151	185	172	162	51	79	+	100	1,107
+	26	+	55	143	145	143	140	+	88	50	50	+
*Stapledon, E. A. . . . .	19	121	70	120	115	102	160	+	66	+	70	824
+	17	+	60	134	130	150	127	+	67	50	75	+
*Young, H. A. L. . . . .	30	117	55	119	165	159	167	—	—	—	—	782

REMARKS.

• First-class certificate and life membership.

† Second-class certificate.

a Optional subjects.

— Did not attempt.

+ Failed, not having obtained half the maximum marks in the subject.

13. In view of the fact that eight of the candidates who originally entered failed to present themselves at the Examination, the Committee recommend that the deposits of such of them as were not absent on account of ill-health be retained by the Society for the present. They also recommend that in future the deposit paid by an absent candidate should not be returned, unless such candidate presents himself for examination within the two following years.

(Signed) MORETON,

June 2, 1891.

Chairman.

### EXAMINATION IN AGRICULTURE.

MAXIMUM NUMBER OF MARKS FOR THIS PAPER, 200.

PASS NUMBER, 100.

*Tuesday, May 12th, from 2 p.m. till 5 p.m.*

N.B.—It is hoped that all the questions will be answered. Nos. 1, 2, 7, 8 may be answered shortly. Nos. 3, 4, 5, 6 should be answered as fully as time will allow. Base all your answers upon the average conditions and prices of the year 1890. Leave a margin to the left hand of your paper, and six lines, at least, clear after each answer.

*Assume that you intend to adopt Agriculture as an occupation and for a livelihood, that you require a farm, and have the capital to stock it.*

#### FARM.

##### *Description.*

1. State shortly the description of farm that with the present agricultural outlook you would select; state your reasons and the points to which you would pay particular attention in such selection. State how you would judge of the climate and of the soil, and its capabilities of production.

##### *Capital.*

2. State shortly the acreage, the time of entry, the system of farming which you would adopt, the rent (to include tithe) at which you think such a farm could be taken, the capital you would consider necessary for the farm proper (apart from the house), and how you would allocate it.

*Assume that you have been in occupation of such a farm for a few years, that it is in proper rotation and condition, and that you are farming it according to the system stated above. Describe generally the management of the farm for one year under the following heads, viz.:—*

#### RECEIPTS FROM FARM.

##### *Crops.*

3. State the rotation and acreage of cropping, with the general management of each crop respectively, both as regards arable and grass land, specifying annual produce per acre and receipts from produce sold.

*Live Stock.*

4. State number, description, and general management of the live stock (farm horses included), giving annual purchases and sales with prices and amounts.

*Dairy.*

5 Describe the general management of the dairy (if any), and give annual receipts from dairy produce sold.

## EXPENDITURE UPON FARM.

*Manual Labour.*

6. State number, description, and wages of labourers that you would employ, specifying extra work and piece work, with prices, showing annual expenditure upon manual labour.

*Feeding Stuff, Manure, &c.*

7. State shortly the annual expenditure respectively upon cakes and feeding stuffs, manure, seed grain and other seeds, renewals and repairs to implements, machinery, &c., tradesmen's farm bills, rates, taxes, insurance, &c.

## SUMMARY.

*Profit and Loss.*

8. State shortly any other items, with the amounts, which should be included under the head of farm receipts or expenditure, and show the financial result of the year's farming.

## VIVÂ VOCE EXAMINATION IN AGRICULTURE.

MAXIMUM NUMBER OF MARKS, 100. PASS NUMBER, 50.

*Wednesday Afternoon, May 13th.*

## EXAMINATION IN BOOK-KEEPING.

MAXIMUM NUMBER OF MARKS, 200. PASS NUMBER, 100.

*Friday, May 15th, from 10 a.m. till 1 p.m.*

Journalise the following transactions: post them into a ledger: make out a Profit and Loss Account and a Balance Sheet.

On September 30, 1889, John Thompson receives from his father, Henry Thompson, 4,000*l.*, and agrees to pay him interest at the rate of 3 per cent. per annum.

He becomes tenant of a farm at a rent of 400*l.* a year, and pays the outgoing tenant for—

	£	s.	d.
Horses . . . . .	180	0	0
Hay, Straw, and Feeding Stuff . . . . .	325	0	0
Live Stock, <i>i.e.</i> Cattle, Sheep, Pigs, and Poultry . . . . .	400	0	0
Implements . . . . .	150	0	0
Growing Crops, Tillages, and Manures . . . . .	520	0	0
He deposits in the Bank . . . . .	2,425	0	0

He draws cheques during the year for—

House expenses . . . . .	106	0	0
Wages . . . . .	880	8	0
Rent . . . . .	100	0	0
Rates, Taxes, and Insurance . . . . .	75	5	0
Petty Cash . . . . .	35	0	0
Seeds and Manures . . . . .	308	4	6
Horses . . . . .	55	0	0
Cattle . . . . .	607	10	0
Sheep . . . . .	710	15	0
Pigs . . . . .	43	0	0
Implements . . . . .	175	0	0
Tradesmen's bills . . . . .	96	7	6

His bills for Feeding Stuffs amount to 350*l.* 9*s.*, and he pays 200*l.* on account of them.

He receives and pays into the Bank for—

	£	s.	d.
Corn sold . . . . .	403	5	9
Cattle „ . . . . .	406	10	0
Pigs „ . . . . .	57	0	0
Wool „ . . . . .	60	0	0

He sells 250 sheep at 35*s.* a head to J. Matthews, and receives from him 375*l.* on account.

He sells to his Landlord 50 loads of Hay at 3*l.* 10*s.* and 20 loads of Straw at 30*s.*

On Sept. 29, 1890, his valuations are :

Cattle unsold . . . . .	633	0	0
Sheep „ . . . . .	740	0	0
Pigs „ . . . . .	30	0	0
Poultry „ . . . . .	7	0	0
Horses „ . . . . .	210	0	0
Corn „ . . . . .	707	0	0
Hay and Straw unsold . . . . .	226	0	0
Growing Crops and Tillages . . . . .	825	0	0
Foods purchased . . . . .	183	10	0
Seeds and Manures . . . . .	175	0	0
Petty cash in hand . . . . .	6	5	2
Unpaid Tradesmen's bills . . . . .	28	7	4
Implements at cost price, less 8 per cent. for depreciation.			

## EXAMINATION IN CHEMISTRY.

MAXIMUM NUMBER OF MARKS, 200. PASS NUMBER, 100.

### A. GENERAL CHEMISTRY.

Thursday, May 14th, from 10 a.m. till 1 p.m.

1. Give an account of the properties of nitrogen, and of its oxides.
2. Describe the preparation of hydrochloric acid, and explain the chemistry of the process. Show, by examples, the chemical action of that acid on different metallic oxides and hydrates.
3. Explain how you could determine the proportion of sulphuric acid in a sample of ammonium sulphate. How could you detect calcium sulphate and sodium sulphate if they were mixed with the ammonium sulphate?

4. Show how to determine the amount of water vapour in the air at any given time and place. Point out the causes which tend to equalise the distribution of water vapour in the atmosphere.

5. What gases are usually found in solution in rain water? How may they be extracted? What circumstances increase the solubility of gases in water? Give examples.

6. Sulphurous acid, ferrous sulphate, and grape sugar are all reducing agents: explain what this means, and give examples in illustration of their reducing action.

7. Give some account of the occurrence in nature, and of the properties, of alumina and its hydrate.

8. What are the grounds for regarding carbonic acid as a dibasic acid? Calculate the weight of slaked lime needed to convert 1,000 grams of carbonate of soda into caustic soda, and to convert a like weight of the bicarbonate also into caustic soda. ( $\text{Na} = 23$ ,  $\text{Ca} = 40$ .)

9. What is the relation between urea and ammonia; and how may urea be made to yield ammonia?

10. Explain the chemical relations of starch, sugar, and cellulose. Plants produce such substances from carbonic acid and water under the influence of sunshine: show on what principle sunshine is necessary for the result.

## EXAMINATION IN CHEMISTRY.

MAXIMUM NUMBER OF MARKS, 200. PASS NUMBER, 100.

### B. AGRICULTURAL CHEMISTRY.

*Thursday, May 14th, from 2 p.m. till 5 p.m.*

1. The occurrence of chloride of sodium (common salt) in a soil may be the cause of its infertility, so also may the presence of certain compounds of iron. State whence these may arise, in what quantity the former (chloride of sodium) is known to be injurious, and how they may be removed.

Account for the fact that, despite the above, both common salt and sulphate of iron may be used as manures.

2. Take the case of a country which exports to a large extent its grain crops, and returns only about one-quarter of the straw in the form of manure, this being practically the only manurial source available, what would you say should be the agricultural condition of the soil as regards its capability for producing future crops? Explain in what ways natural richness or judicious rotation might affect the result, at least temporarily.

3. What is an "oil-cake"?

What are the principal objections to the use of the term "oil-cake," and why should farmers insist upon being supplied with "pure linseed-cake"?

4. Which are the principal "sugars" that are met with in agricultural chemistry? Give the chief occurrences and properties of each.

5. Discuss, quantitatively, the rainfall as a supplier of food to plants. What causes may produce variations in its composition?

6. Explain what differences a field may exhibit in the succession of crops grown upon it, according as to whether it has been old pasture land recently ploughed up, or has been for a long time arable. To what chemical causes may these be due?

7. Give examples of the effects of high manuring on crops, as regards quantity, maturity, and chemical composition.

8. What is animal charcoal? How is it produced, and to what does it owe its purifying power? How does wood charcoal differ from it?

## EXAMINATION IN MENSURATION AND LAND SURVEYING.

MAXIMUM NUMBER OF MARKS, 200. PASS NUMBER, 100.

*Tuesday, May 12th, from 10 a.m. till 1 p.m.*

1. What is the numerical value of an acre, expressed (a) in square yards, (b) in square chains, (c) as a fraction of a square mile?

A rectangular piece of land has an area of 9 acres 2 roods 37 poles; the length of one side is 9.94 chains; what is the length of the adjacent side?

2. What is the number of yards in the diameter of a circular enclosure whose area is one acre? (N.B.  $7\pi = 22$ .)

What would be the number of yards in the diameter if the area were 20 acres 1 rood?

3. Pieces of round timber, each  $9\frac{1}{2}$  feet long, are cut into planks; in the process the following cuts are made: 15 cuts 25 inches deep, 15 cuts 22 inches deep, 3 cuts 13 inches deep, and 34 cuts 6 inches deep; what will be the charge for the cuts, at 5 shillings a hundred square feet?

4. A solid of irregular shape is found to weigh 75,423 grains in water, and 84,537 grains in air; find the volume of the solid, having given that a cubic inch of water weighs 252.8 grains.

What would the calculated volume be if it were assumed that the weight of a cubic foot of water is 1,000 ounces (avoird.)?

5. A and B are two accessible points, not very far apart, separated by a pond, or other obstacle; show how to lay down on the ground a line equal in length to A B, using only tapes and pickets, and without producing any short line, or measuring any angle.

6. A B C D E is a piece of ground enclosed by five lines; the following lengths are measured, viz.: the sides, A B 2,875, B C 3,648, C D 4,020, D E 4,874, E A 3,578, and two diagonals, A C 6,126, A D 4,783; all in links. Take the line A C to be three inches long and draw a scale; then, using the scale, draw a plan of the ground, and find its area from the plan.

7. A, B, C, D, E, F are points in succession along a road, and the surveyor is supposed to be going from A to F; he first puts his level at X, between A and B, and afterwards at Y, between E and F; the levelling staff is held successively at A, B, C, D, E, F, and the following entries are made:

Station	Back Reading	Intermediate	Forward	Distance
X .	6.40	—	—	—
	—	13.21	—	300
	—	3.78	—	650
	—	8.04	—	1,680
Y . . .	—	—	12.92	2,179
	3.15	—	—	—
	—	—	6.75	3,207

The distances are, of course, from A to B, B to C, &c., and are in links. Complete the form by entering rise, fall, and reduced level, assuming that A is 20 feet above the datum line; and draw a section of the ground, using as a horizontal scale 1 inch equal 5 chains, and as a vertical scale 1 inch equal to 10 feet.

8. A, B, C are three points; from A to B is 1,200 yards, from B to C is 2,874 yards; at A, A B bears N.  $23^{\circ}18'$  W., and at B, B C bears N.  $72^{\circ}47'$  E.; calculate the distance from A to C, and the bearing of A C at A. Verify the results by construction, using a scale of 1 inch equal to 500 yards.

EXAMINATION IN AGRICULTURAL ENGINEERING.

MAXIMUM NUMBER OF MARKS, 200. PASS NUMBER, 100.

*Wednesday, May 13th, from 10 a.m. till 1 p.m.*

N.B.—*Not more than half the questions should be attempted.*

1. Explain what is meant by elastic limit and ultimate stress in materials.

2. What conditions are to be observed in designing surfaces which are to work on each other, as, for example, axles in their bearings, or the slide blocks guiding the piston-rod cross-heads of steam engines on their slides?

3. Describe the construction and the mode of graduating an ordinary mercurial thermometer, and state what is meant by the absolute zero of temperature.

4. Explain what is meant by "temperature," by "specific heat," and by "latent heat."

5. Explain the cause of the difference of specific heat of gases at constant volume and at constant pressure.

6. Explain and illustrate by sketches the action of wind upon the sails of a windmill.

7. Sketch an ordinary single-acting 3-inch hand suction and force pump, such as is commonly used in wells or for domestic supply. Mark the principal dimensions.

8. What is the usual method of freeing water from mechanical impurities and rendering it fit for domestic use? Sketch and describe an installation to yield 3,000 gallons per 24 hours.

9. Describe the process by which the potential energy in coal is converted into useful work by means of a non-condensing steam engine.

10. A condensing steam engine is required to work up to 30 indicated horse-power measured in the cylinder. Calculate the quantity of feed and of condensing water required per hour. You may assume such boiler pressure, temperatures of water, and efficiency of the engine as you think will probably obtain in a good engine.

11. What is the difference between a gas and a petroleum engine?

12. Sketch carefully and dimension as far as you can a 12-inch metallic piston.

13. Describe the system of steam ploughing by means of two engines and a balance plough.

14. Sketch and describe a horse-hoe.

15. What is the use of a horse-rake? Describe its action, illustrating your description by sketches.

16. Sketch an ordinary cart-wheel, and describe its various parts.

17. Describe a chaff-cutter, and illustrate your description by sketches, and explain the safety appliances.

18. Show how two lay shafts, say 10 feet apart and crossing each other at right angles, can be driven by a flat belt so that there will be no tendency of the belt to come off. State whether the direction of revolution is a material factor in the arrangement.

---

## EXAMINATION IN BOTANY.

MAXIMUM NUMBER OF MARKS, 100. PASS NUMBER, 50.

*Friday, May 15th, from 2 p.m. till 4 p.m.**Seven questions at least must be answered.*

1. Describe the apex of the root and its method of growth; wherein does it differ from the growth of the stem?
2. What are the principal constituents of the ash of a plant, and how did the plant obtain them?
3. Explain: Endosperm, dicotyledon, glume, spore, hybrid, mycelium.
4. State the cause or causes of the death of a seed.
5. Describe the fruit and seed of wheat: what are the parts of the embryo, and what are their different functions in germination?
6. Describe the nature of hop mildew, and state what preventive or curative means you would employ in dealing with it.
7. What grasses and other plants are suitable for laying down permanent pasture in a good and well-drained soil? Give your reason for the selection of each specimen.
8. Describe in some detail one of these parasites—ergot, dodder, or broom rape—giving its natural order, host plant, method of attack, resultant injury, and suggestions for remedy.
9. Give the characters of the natural order Umbelliferæ, and specify some cultivated plants of the order, and some dangerous plants found in Britain.
10. Name and describe in systematic order the plants marked A and B.

## EXAMINATION IN GEOLOGY.

MAXIMUM NUMBER OF MARKS, 100. PASS NUMBER, 50.

*Saturday, May 16th, from 10 a.m. till 1 p.m.*

1. Describe some of the most common kinds of Granitic rocks, and state where they occur in the British Islands.
2. Illustrate by diagrams *folding* and *contortion* of strata, also *unconformity* and *overlap*. What inferences, with reference to geological time, can be drawn from these conditions of strata?
3. What are the main directions of *strike* and *dip* in the strata constituting England? What Surface-features do you recognise in association with those conditions?
4. What Fossils would serve to show that a series of strata had been formed under freshwater (river or lake) conditions, and what would show that they had been formed in the sea?
5. What are the organic constituents and the chemical composition of Peat? Describe the mode of its formation?
6. Mention the localities where Peat chiefly occurs in the British Islands. State how it used to be made serviceable as a manure, and what it is used for at the present day.
7. Describe in detail of what and how sands, clays, and limestones, respectively, are formed in nature.



8. Enumerate the chief Limestones of the British Islands, and state for what purposes they are respectively used.

9. Draw a Geological Section across any part of the British Islands, and describe it in detail.

10. Write a brief essay on the Physical Geography and Geology of any one of the large Counties in England, Wales, Scotland, or Ireland. Give one or more sketches or diagrams in illustration.

11. For any *six* of the following Genera, state the Natural Order to which each belongs, and mention one or more of its species, with the Geological Formations in which they are found: Ananchytes, Anthracosia, Asaphus, Baculites, Belemnites, Belinurus, Calymene, Cidaris, Coccosteus, Dalmanites Dentalina, Dicerias.

12. Name and describe *four* of the Specimens on the Table.

---

### EXAMINATION IN ANATOMY AND ANIMAL PHYSIOLOGY.

MAXIMUM NUMBER OF MARKS, 100. PASS NUMBER, 50.

*Saturday, May 16th, from 2 p.m. till 4 p.m.*

1. Given that the digestive organs of ruminating animals are more complex than those of other animals, name the several divisions of the stomach of the ox, and say in which digestion is effected.

2. On inspection of a small portion of each of these divisions, say how you would recognise to which of them it belonged.

3. Describe in general terms the anatomy of the heart, making especial mention, however, of the vessels which convey the blood to and from it in both the systemic and pulmonic circulation.

4. What is meant by the term of a standard pulse, and what is the average number of healthy pulsations in the horse, ox, and sheep?

5. Explain the difference which exists in the condition of the heart and that of the arteries when their pulsatory action is felt.

6. State how the normal temperature of the body is maintained, and under what circumstances it would become increased, or, on the contrary, diminished.

7. Name the several blood-vessels which unite to form the large vessel that enters the liver for the secretion of bile, and give the name of the vessel.

8. Say into what part of the intestinal canal the biliary duct enters, and name the animal of the farm in which a gall-bladder does not exist.

9. Say on what the variation in the colour of the skin depends in pied animals, and name the parts of the body where an accumulation of some of the follicles of the skin exists, and give an illustrative example.

10. Name the divisions of the vertebral column, and state the relative number of bones in each division in the horse and ox.

11. Given that bones of the vertebræ form a continuous cavity, say what is lodged within it and name the chief function of such encased organ.

---

## EXAMINATION IN AGRICULTURAL ENTOMOLOGY.

MAXIMUM NUMBER OF MARKS, 100. PASS NUMBER, 50.

*Friday, May 15th, from 4 p.m. till 5 p.m.*

*Candidates will not be expected to answer all the questions in this paper. The replies are to be as short as possible, and where the candidate is not acquainted with the scientific name of an insect, the generally received English name will be accepted.*

1. Name some of the insect attacks most commonly injurious to turnips—as to the crop in the seed leaves; or to the leafage generally; or to flower or seed; or to roots.
  2. Describe a few of the chief characteristics of attack of turnip flea-beetle, or of some other common turnip attack.
  3. State very shortly some of the measures of treatment of land beforehand, or of treatment of the growing crop, which are useful for prevention or remedy of attack of turnip flea-beetle.
  4. Give some of the reasons why good cultivation of land, or stimulating dressings, or sometimes date of sowing, act well in lessening amount of harm from insect infestation.
  5. Say what treatment you would think desirable before, and during course of, breaking up old pastures or clover leys, in order to lessen amount of wire-worm presence.
  6. How can you tell the difference between various kinds of larvæ, *i.e.* between the maggot of a two-winged fly, and the grub of a beetle, or the caterpillar of a moth or butterfly (speaking generally, and not noting exceptional cases)?
  7. Give examples of an order of insects, or of some special insects, which are injurious only in the larval stage; or in both larval and imago (or perfect) stage; or in all three stages, *i.e.* as larva, pupa, and perfect insect.
  8. How do insects breathe, or draw in air?
  9. How would you apply the knowledge of method of inhaling air supplies practically, as a means of checking attack, say of ox warble maggot, or of *aphides* (or plant lice) in any stage?
  10. State, giving the scientific or popular name of the infestation, what it is that causes the deformed growths known as "tulip root" or "segging" in oat plants, and as stem-sickness in clover.
  11. Mention what kind of chemical applications have been found successful both for prevention and remedy of tulip root and stem-sickness.
-

# Notes, Communications, and Reviews.

## HARVESTING THE SEED OF ROOT-CROPS.

THE root crop of the United Kingdom covers nearly 3,000,000 acres annually, which necessitates the growth of at least three times as many pounds weight of seed to sow the land once. During the last few years there has been an almost unprecedented freedom from the attacks of the turnip-fly and other injurious insects; and, as the seasons have been moist at the time of seeding, very few acres have required re-seeding. It frequently happens, however, that for a series of years a very considerable breadth has to be re-sown. Seed-merchants have to be prepared for such an emergency, and it thus becomes necessary to grow much more seed than is required for sowing the land once. Roughly, at least 10,000,000 lb. of seed are required annually, and this, at an average weight of 50 lb. per bushel, means that 200,000 bushels of sound seed are required for the home trade alone. In addition to this, however, a large export trade has to be met.

The yield of seed is very variable, and, although 35 bushels are grown with some frequency, 20 bushels is a good average yield of turnip seed per acre, notwithstanding the high culture to which the crop is subjected. The growing of this class of seeds is therefore an important branch of agriculture.

By far the greater portion of the seed is obtained from small plants produced in seed-beds sown in August and transplanted in the autumn, or occasionally in February, when the land has been unfavourable for the work earlier. Great care is taken to keep the land free from weeds and generally in a high state of cultivation. The earliest seed ripens in July.

The White Turnip is the first to ripen, and is closely followed by the Hybrid variety. The Swede is generally from ten days to a fortnight later. Kohl-rabi, Thousand-headed Kale, and Cabbage come very soon after the Swede. Mangel is very much later, not being fit to cut before September, and occasionally October.

The seed of the cruciferous plants is not allowed to become thoroughly ripe before being cut, or great loss results, for when it is

perfectly ripe the seed falls out with ease, a mere shaking by the wind being sufficient to dislodge a large proportion. As the plants are set close together, varying from 40,000 to 60,000 per acre, and as these grow into stout shrubs, 3 feet or 4 feet in height, which throw out lateral branches so as to form a dense growth in which the individual plants are almost lost, a considerable amount of pulling is necessary to disentangle them, especially, as is often the case, when the crop has fallen flat on the ground. The crop is therefore cut at the time when the sap has commenced to leave the plants, when the pods are turning yellow, and the seed has lost its greenness. If cut too soon the seed does not ripen thoroughly, which is indicated on threshing by the purple rather than the black colour of the sample. If the land is weedy this crop must be cut sooner than it otherwise would be, as the weeds tend to mat it together, causing it to be more difficult to pull out the plants, and thereby entailing great loss of seed. If the seed is not sufficiently ripe its germinating powers are weak. Some judgment is therefore necessary in determining the best time for commencing to cut. The cutting is generally done by the piece, and costs, according to the quality of the crop, from 7s. to 10s. per acre, 7s. 6d. to 8s. 6d. being the usual price paid. A short fagging-hook is most commonly used, and the worker grasps the stems of the plants with one hand whilst he chops with the other. The handful is then drawn out, and laid in bundles or sheaves. It is, however, not usual to tie them, although this is occasionally done.

The sheaves are left on the ground for a week or two, in order to become thoroughly dry and ripened, and it rarely happens, even under the most favourable conditions, that they are fit to thresh in less than a fortnight. If threshed before absolutely dry, the seed heats subsequently, and if not carefully handled is ruined. Whilst on the ground the sheaves are turned occasionally, so that the seed may be equally ripened throughout, and also to prevent the seed from growing when the weather is wet. It is a very anxious time for the farmer, as a strong wind, especially a whirlwind, often turns the sheaves and knocks out many bushels per acre. A hailstorm or heavy thunder shower will frequently knock out half the seed, and in continued wet weather much of it begins to grow. Every turning occasions loss, and as it becomes riper the loss is proportionately greater. The best plan is to turn the sheaves while the dew is on them, as the pods are tougher then. Turnip-seed shells out the most easily, whilst Kale and Cabbage suffer least in this respect.

It is not usual to stack the sheaves, as much loss of seed is inevitable during the moving, and there is great increase in the expense. Nevertheless, it is sometimes found advisable to stack in seasons when there is great absence of sunshine, for it is otherwise impossible to get the seed sufficiently dry for storing without leaving it subject to loss from the meteorological causes already mentioned. The threshing is therefore generally carried out in the field, and it is one of the busiest sights on the farm. All the seed will not knock out unless it is absolutely dry, and though three-

fourths of the seed might fall out with the greatest ease the remainder would be very obstinate. The threshing can only be carried out whilst the seed-pods are quite free from moisture, and there are few mornings sufficiently free from dew for a start to be made before 8 o'clock, whilst after heavy dews and mists threshing cannot be commenced before noon. So susceptible is the seed-crop to moisture that the effect of dew in the evening can be realised by the workers on the threshing-cloths before it can be felt by hand, or is shown on the shoes of those who are loading in the field. The threshing-day is therefore a limited one, and one of ten hours' duration is very exceptional. All available hands are gathered together as soon as a start is considered advisable, and a piece of ground is cleared of stumps and other inequalities, so that the threshing-cloths may be laid down. For a moderately large set, such as will be described below, two cloths, each 10 yards by 12 yards, carefully sown together so as to retain all the seed, are firmly pinned down with iron pins. It is necessary that the sheets should be stretched very tightly, or the forkings, rakings, and brushings will be rendered troublesome.

The usual arrangement of hands is that there should be two sets of loaders in the field, each composed of two pitchers and a lad to steady the load, which is not piled very high. All of it is laid inside the "raves" of the cart, or the seed would jolt out while in transit to the cloths. Large seed-growers provide special carts for carrying seed: these are made with long bodies, 12 feet to 14 feet in length and 7 feet wide, the sides being hinged as in railway trucks, so that they may be let down, and the load rolled out quickly. Great care must be taken to pick up the sheaves in such a way that the seed does not shake out. If the fork is stuck carelessly into the seed end, or if the sheaf is lifted with a jerk, there is much loss. It must be slipped between the stems, and lifted with a smooth even motion straight to the cart. The loads are taken to the cloth, and are rolled on to it, the sole duty of one man being to empty. Two men receive the material and immediately lay it in long wads, nearly the full length of the cloth, and two iron rollers, each ridden by stout lads, or by the master or his sons, are driven up and down the wads twice, these being rapidly turned to receive a fresh rolling. This rolling and turning are continued until the wad has crossed the cloth, the rapidity being controlled by the ease with which the seed comes out. The haulm is then stacked outside the cloth; or, as is often preferable, loaded on to carts for use elsewhere as stack-bottoms. In all, five to seven men are engaged working the wads across the cloths, and loading up the straw, all finding employment, as at some periods there are two wads in working at the same time. Besides these, three men are engaged in raking off the pods, and another man in brushing the seed into a heap. The seed is then put on to a coarse riddle 6 feet in length and 3 feet 6 inches in breadth, and the coarse material is worked off, the seed being then passed through the winnowing to separate the chaff and dust, this employing five or six additional hands. The seed is now

sacked up. About 130 bushels of seed may be thus threshed and cleaned in the course of a good day's work. If the seed is not cleaned at the time, there is an excessive amount of labour involved in bagging up and carting home, for, after the pods are separated, a sack (of 16 pecks) would only contain about 5 pecks of seed.

About 25 hands all told are required for the entire operation, and to those unaccustomed to the process it is surprising how rapidly and systematically it is done. It compares very favourably with the leisurely manner in which most of the work on the farm is carried out. A slightly different process is sometimes contrived on the cloths, when the wads, instead of being straight, are made horse-shoe shape, and the seed is worked into the centre. The riddling goes on here also, and the seed is worked towards the heel of the shoe, finally passing out through the winnower, to be then bagged up.

Mangel-seed is rather more expensive to cut, costing from 8s. to 10s. per acre. It is cut when a brown shade has spread over the plant, but it cannot be left until the whole of the plant dies down; in fact, the plant has to be killed. The crop is not fit to cut until September, and occasionally until October. It is cut with a fagging-hook, and tied and shocked like wheat. After standing for some few weeks it is stacked in narrow stacks, to prevent its heating, and is threshed out by the steam threshing machine.

The price paid for the seed of root-crops has rendered its growth unpopular, for, with the risks which attend it at all stages, it is found to be a precarious enterprise. Some idea of the hazardous nature of the crop may be gathered from the fact that insurance companies, which insure against damage from hail, charge 15s. per acre for turnip-seed and only 4*d.* for wheat. The low price of wheat induced many new growers to take up the growing of seeds, with the result that the price now paid is less than two-thirds of what it was a few years ago. If wheat should maintain the price it reached in May of this year, it is very unlikely that farmers will be found to grow seed of root-crops at the present prices. Wheat-growing is more reliable, and at current quotations more profitable.

W. J. MALDEN.

---

## FARMERS' ACCOUNTS.

THE question of technical education for farmers now being considered and discussed is no doubt an important one, as scientific training and more complete technical knowledge are necessary to enable farmers to meet the altered state of prices brought about by foreign competition.

The ground-work of improved education should be the science of arithmetic, now taught in every board school. The farmer

should learn first to keep a cash-book, and ledger, which would be a true record of all his transactions, and from which profit and loss accounts of a reliable character could be made. Until farmers put this system into practice they can have no accurate knowledge of how they are progressing or where losses occur. It is the keeping of accurate accounts, with a proper cost-book, that enables our manufacturers to compete successfully with unrestricted importations of every kind. It is the acknowledged and universally adopted principle upon which competition is met, and farmers as producers of commodities subject to this intense competition can claim no exemption from the general rule if they wish to succeed in their occupation. It will of course give them some additional trouble, but this is a necessary consequence of increased competition which all producing industries have had to contend with. Farm accounts of *cost* are difficult to keep, but nevertheless they can be kept, so as to be of great practical value. Balance-sheets are easily made, and are necessary to show the net result of the year's transactions, but more than this is wanted. Profit and loss accounts of cattle are also easily kept, when live weight is adopted as a basis of calculation, but not otherwise, if the cause of loss is to be ascertained.

Referring to the cattle trade, which is the largest and one of the most important of agricultural industries, no satisfactory cost-book (record of accounts) can be kept without introducing the element of weight as the basis of calculation. It is the only *fact* that can be ascertained on the subject, and my proposition is to substitute this *fact* for a mere matter of opinion, the variations of opinions being such that they cannot be represented by figures.

It is not sufficient for a banker's account to show *when* losses have been sustained, if it does not also show *where* and *how* they have been incurred. It is this latter knowledge that is required, in order that a repetition of the loss may be met, and if possible avoided.

The proposition to base calculations on the live weight of cattle is a perfectly practicable one, and not new; but in England the proper means have not been provided for carrying it out. Farmers are good judges of the quality and breed of stock best suited to the land they occupy. This their experience teaches them. But they want more accurate knowledge of the weight they are buying and the weight they are selling, or in other words the quantity to be bought or sold, which is a distinct question from quality, and the answer to which can only be given them by the scales. A weighing machine is as necessary an implement on a stock farm as a plough on an arable farm, if any accurate knowledge of the size, growth, and value of stock is to be obtained.

My own experience is that if the right kind of stock be selected, they will put on 27 or 28 live stone (14 lb.) farm weight during the period of summer grazing. I give from 20s. to 25s. worth of cake in the two months before they are sold. The whole of this 27 or 28 live stones gain in weight is not the grazier's to sell, as

cattle lose fully five per cent. in going to market and standing there. There is therefore only 22 or 23 stone available for sale. If a butcher comes to my farm I take him off five per cent. from the farm weight, thereby reducing it to market weight. I consider that if store cattle are to pay the grazier a fair profit, they should be bought in the autumn at 1s. to 1s. 2d. a live stone less than the average price of beef per live stone when they are sold, and if bought about May 1, at 6d. a live stone less. An official record of live weight prices of store cattle would therefore be a most valuable guide.

This has not been possible the last year or two, except in the case of Canadian stores, which have been bought more in accordance with the price of beef. Autumn buying of stores must depend upon the means a farmer has of keeping them through the winter without losing weight, and it is desirable that grazing farms should have a little arable land attached, though details of this kind are well known to all practical farmers. The price of stores will of course always be subject to variations, but if farmers would accustom themselves to take the weight of their store cattle at the time of purchase, it would be a check upon their own judgment and would help to check the great variety of prices often given for the same class of cattle, in the same market, on the same day; and in a short time they would know what they could afford to give. The live weight at the time of purchase would also be a valuable record, as by taking the live weight when sold fat, it would enable the graziers to see what their land had done, and also which breed of cattle had fared best. All this is at present conjecture and matter of opinion, but it would be far more satisfactory to have it as matter of fact. The buying in of stores is a most important question to all feeders of cattle. The smaller cattle of good quality under 90 stone alive at market make the most money and do not come so much into competition with the American killed beef as does the larger class of Shorthorns weighing 100 live stone and upwards.

With respect to the sale of fat stock, the quality and condition will determine the price per live stone, and of this the farmers who have fed the cattle will be the best judge. They will soon learn the percentage of dressed meat the stock are likely to yield. A moderately well-fed animal will yield about 57 per cent., the better fed animals as much as 60 or 61 per cent. All cattle will of course vary more or less in the percentage of meat they yield, which must be arrived at by taking averages. If cattle are picked as they are ready to be sold, a good judge will estimate their carcass yield to within one or two per cent. Many butchers are very good judges and keep accurate accounts of the live weight of the cattle they buy as well as of the dead weight of meat they yield, and are perfectly able to buy their fat cattle by live weight, and many do so. A farmer may kill a test beast or two in average condition, and, taking the fasted live weight and dead weight, this will be a guide to the percentage of meat they are likely to yield. Or he may sell a few to a local butcher by weight, and see them weighed, and in this way much



valuable information may be gained. In a short time the system would become familiar, and no possible harm could result from adding such reliable information to a farmer's present knowledge, as it would do away with one of the two great elements of uncertainty that now exist, and assist his judgment in valuing the other.

WESTLEY RICHARDS.

---

---

## SOME REMARKABLE FEATURES IN THE WINTER OF 1890-91.

THE abnormal character of the recent winter continues to be made the subject of investigation on the part of meteorologists. In a paper read before the Royal Meteorological Society on April 15 last, Mr. Frederick J. Brodie, F.R.Met.Soc., remarked that the peculiarities in temperature were by no means the only features of interest in a very extraordinary season. A cold winter is usually, though not invariably, brought about by an undue prevalence of anticyclonic<sup>1</sup> conditions, and there has been no season within recent years in which this characteristic was more strongly marked than in that of 1890-91.

*Barometric Pressure.*—During the frost, which lasted from the close of November to about January 21 or 22, the weather over England was affected mainly by a huge high-pressure system which extended over the Continent from Russia. In February the Russian anticyclone gave way, but a new one advanced over France and

---

<sup>1</sup> As this term is of frequent occurrence the following elucidatory notes are taken from the Hon. Ralph Abercromby's *Weather*, pp. 7, 47: "Within the last twenty years a new treatment of weather-problems has been introduced, by which the whole aspect of meteorology has been changed. By this method a chart of a large area of the earth's surface is taken, and after marking on the map the height of the barometer at each place [at one and the same time], lines are drawn through all stations at which the barometer marks a particular height. Thus, a line would be drawn through all places where the pressure was 30.0 inches, another through all where it was 29.8 inches, and so on at any intervals which were considered necessary. These lines are called *isobars*, because they mark out lines of equal pressure."

"An *anticyclone* is an area of high pressure surrounded by nearly circular isobars. These are always a considerable distance apart, and extend over a large area. The pressure is highest in the centre, and gradually diminishes outwards. The air is calm and cold in the central portion, while on the outskirts the wind blows round the centre in the direction of the hands of a watch, not exactly parallel to the isobars, but spirally outwards. Unlike a cyclone, which is commonly in rapid motion, an anticyclone is often stationary for many days together."—ED.

Germany from the south-westward, and as the borders of this system extended northwards over a considerable portion of our islands, the conditions over England remained, for the most part, under the influence of high barometer readings. As a result of the very marked persistence of anticyclonic weather it appears that the mean pressure over the British Isles was above the average in all three of the winter months. In December 1890 the excess was slight in the southern parts of the United Kingdom, but large (0·3 in. or more) in the north and east of Scotland. In January 1891 the difference from the mean amounted to between 0·10 and 0·15 in. over Great Britain, but to 0·20 in. in the south of Ireland. The most remarkable difference was, however, in February, when the mean pressure over the United Kingdom was from 0·3 to 0·5 in. above the average in all districts, the greatest excess being found over England and the east of Ireland. At Kew Observatory, the mean pressure for February derived from the hourly readings of the self-registering barograph was no less than 30·474 ins., or 0·479 in. in excess of the average for the twenty years 1871-90, and 0·087 in. higher than in any month of the same extended period.

The effect of so constant a prevalence of anticyclonic conditions upon temperature has been dealt with in Mr. C. Harding's paper on "The Great Frost of 1890-91" (see page 196 of this volume of the Journal). Its influence upon the winds, the weather, and the rainfall of the winter were no less marked, and are deserving of special notice.

*Wind.*—Firstly, as regards the wind, we find that over the United Kingdom generally the winter was unusually quiet. Even in the extreme west and north, where the weather was influenced from time to time by low-pressure systems which advanced from the Atlantic, the gales experienced were neither frequent nor severe, while over England there was an almost entire absence of the ordinary winter storms.

The influence of repeated anticyclonic weather during last winter is shown very forcibly by the unusually high percentage of calms in London, the actual value (22 per cent.) being more than double the average, and considerably higher than in any other winter of the past twenty years. The number of gales experienced in the Metropolis was only two as against an average of seven, and of severe gales there were absolutely none whatever. The weather over this part of the country was, in fact, less stormy than any we have had since the winter of 1875-76, when the number of gales was equally small. In the seasons both of 1876-77 and 1884-85 there were in London six times as many gales as there were in 1890-91.

The prevalence of calm weather was, however, not the only interesting feature. From an examination of the proportion of winds experienced from various points of the compass we learn that there was a very large falling-off in the percentage of winds from between

south and west, and a decided increase in the percentage of winds from between north and east. Taking the points from between south-east and west as representing the equatorial, or mild, winds, we find that the total percentage during last winter was only 38, the average for the previous twenty seasons being 61. Taking, on the other hand, the points between north-west and east, as representing the polar, or cold, winds, it appears that the total percentage was 40, or 10 more than the average for the previous twenty years. Summing up, therefore, the state of the wind as experienced last winter in London, we find that when the weather was not absolutely calm, there was an undue prevalence of breezes from some cold quarter. The percentage of winds from the southward did not amount to one half of the average.

*Fog.*—The anticyclonic conditions which prevailed over England so constantly throughout the winter were accompanied, as one would naturally expect, by frequent fogs, more particularly over the inland districts, and most especially of all in the neighbourhood of London. The gloominess of the weather, as experienced in the metropolis, is shown very forcibly by the subjoined table, which gives for the whole of the past twenty winters the number of days on which fog was reported, together with the average for the entire period, and the actual number experienced in 1890-91.

*Table showing Number of Days of Fog in London during each Winter, 1870-71 to 1890-91.*

Winter	No. of days of fog	Winter	No. of days of fog	Winter	No. of days of fog	Winter	No. of days of fog
1870-71	11	1875-76	22	1880-81	32	1885-86	33
1871-72	10	1876-77	9	1881-82	31	1886-87	39
1872-73	24	1877-78	22	1882-83	32	1887-88	20
1873-74	31	1878-79	23	1883-84	18	1888-89	32
1874-75	17	1879-80	43	1884-85	18	1889-90	32

Average number of days of Fog during the winter . . . 25  
 Actual number experienced in 1890-91 . . . 50

It will be seen that not only was the prevalence of foggy weather in London greater last winter than in any of the previous twenty seasons, but that it amounted to no less than twice the average. The nearest approach to so foggy a winter was in 1879-80, when the number of days was 43, or seven less than that recorded during the winter under discussion. In no other season was the number anything like so great as it was last winter, and in three of the seasons quoted the amount of fog was less than one quarter of that experienced in 1890-91.

*Rainfall.*—In December the aggregate amount of rain was less than an inch in all parts of England, with the exception of the south-western and extreme northern counties, as well as in many of the central parts of Scotland, while in isolated parts of the same localities it amounted to less than half an inch. The amount was, in fact, considerably less than the average in all districts excepting the south coasts of Devon and Cornwall, where, owing to heavy falls which occurred on the 5th and 18th, there was no great divergence from the normal. In January the rainfall was far more abundant than in December, but the amount over the country generally was again much less than the average, the deficiency being most marked in the south-east of Scotland and the north-east of England. The absence of rain in the months of December and January was, however, quite insignificant as compared with the remarkable drought of February. Over nearly the whole of England the total amount of rain in the last-mentioned period was less than a tenth of an inch, the only districts in which this quantity was exceeded being small and isolated portions of our north-eastern, eastern, and south-eastern counties (and even in these localities the aggregate fall was made up largely of water yielded by dew and fog), and the counties of Cumberland, Westmoreland, and Lancashire, where an appreciable quantity of genuine rain fell during the early part of the month. In the neighbourhood of Dublin also the total amount was as small as it was over the greater part of England; but, farther to the westward, as well as in Wales and the eastern parts of Scotland, it increased to between one tenth and one half of an inch, while in the north of Scotland it was in excess of the average. Over the United Kingdom generally the month was in all probability the driest February ever experienced, and in many parts of England it was also the driest month on record, the aggregate fall in some places being absolutely *nil*.

As regards the winter as a whole, it appears that over by far the greater part of England, with the eastern half of Ireland, and the eastern, central, and southern parts of Scotland, the aggregate rainfall was less than half the average, the only English localities in which this proportion was exceeded being the south-western and extreme southern coasts. In portions of Lancashire, the north-eastern counties, and the central parts of Scotland, the amount was less than 30 per cent. of the average, one of the smallest aggregates being at Blackpool, where the winter rains did not amount to more than one-fourth of the normal. Over the south and south-west coasts of England, the western half of Ireland, and portions of central and north-eastern Scotland, the proportion varied between 50 and 70 per cent. of the average, while in the north of Scotland (though not in the Shetlands and Hebrides) the percentage ranged between 70 and 90. In London the winter was not quite so dry as that of 1873-74, but there can be little doubt that, taking England as a whole, it was one of the driest on record.

It must not be forgotten, however, that the deficiency of rain was by no means confined to the winter months. With the exception of the extreme northern and north-western portions of the Kingdom, where heavy rains fell during October and November, the autumn of last year was also unusually dry, this being more especially the case over the eastern, central, and southern parts of England, where the aggregate amount for the season was in many instances less than half the normal. Over nearly the whole of the remainder of England, and also in the south-east of Ireland, the aggregate for the six months was less than 70 per cent. of the average; while over a considerable part of Scotland, with the north of England and the central parts of Ireland, it varied between 70 and 90 per cent. In the north-west of Ireland the proportion of rain was more than 90 per cent., while in the north of Scotland, including the Hebrides, it was in excess of the average. In London the autumn and winter months were, as a whole, the driest on record, and a similar remark applies to Oxford.

It will be seen in conclusion, remarks Mr. Brodie, that, irrespective of the prolonged frost, the season under discussion was characterised by various features which distinguished it from any other winter of recent years. Almost every element in the weather was influenced to an abnormal degree by the remarkable prevalence of high barometrical pressure, and if we were called upon to define the season of 1890-91, we should have little hesitation in giving it the name of the "Anticyclonic" winter.

ED.

---

## LOPPING AND TOPPING TREES.

As many farm leases contain a clause to the effect that the tenant may not "cut, lop, top, or crop" the trees (except pollards) on the farm, it may be useful to report the following case, in which the Court of Appeal recently decided that to "lop" a tree is not the same thing as to "top" one. The case (*Unwin v. Hanson*<sup>1</sup>) arose under the 65th section of the Highways Act, 1835 (5 & 6 W. IV. c. 50), under which magistrates have power to order trees which overhang the highway, or damage it by excluding the sun and wind from it, or which obstruct it, to be pruned and lopped so as to prevent such damage or obstruction. The plaintiff was the owner of land adjoining a highway, and he brought his action against the defendant, who was the assistant-surveyor of the parish highways,

---

<sup>1</sup> Reported in the *Times Law Reports*, Vol. VII. p. 488.

for injuring his trees by improperly cutting them. The defendant relied for his defence on the above-mentioned section of the Highways Act, 1835, and on a magistrates' order made under it which directed him to "lop and top" the trees in question. The plaintiff contended that "topping" and "lopping" trees were different operations, and that though the Act gave power to the magistrates to order the trees to be "lopped," it gave them no power to order them to be "topped." And so the Court decided.

The Master of the Rolls, in giving judgment, said that when Parliament had to deal with matters relating to the general public it used words in their ordinary and general sense, but when it dealt with particular businesses or transactions, and used words which had a particular meaning in connection therewith, the words so used must bear such particular meaning. The Highways Act referred to country matters, and had to be administered by country justices, and it spoke of the "lopping" of trees. It would be mere pedantry for the Court to pretend not to know that "lopping" was always understood by people who had anything to do with trees as meaning the cutting off the lateral branches, and that cutting off the head of the tree was called "topping" it. "Lopping" and "topping" were entirely different, and "lopping" did not include "topping." The defendant therefore, when he "topped" the plaintiff's trees, exceeded the power given him by the Act, which only authorised him to "lop" them, and he must therefore be held liable.

S. B. L. DRUCE.

---

## HAY HARVEST FORECASTS, 1890.<sup>1</sup>

THE results of the checking of the Hay Harvest Forecasts during the haymaking period of 1890 show that, notwithstanding the unsettled weather which prevailed during the summer months of last year, the general percentage of success again reached 89. The same degree of success was attained in 1889, which, to that date, was the highest recorded. The largest general percentage (95) was reached in Scotland, E., while the smallest (86) was in England, E.

The telegrams were sent daily between 3.30 p.m. and 4 p.m. on each week-day for about five weeks, beginning on June 9, in the Eastern and Southern districts of England, and ending on July 26 over the greater part of England, and about a fortnight later in most parts of Scotland.

In addition to the usual recipients, telegrams were sent to six other gentlemen at their own cost. Among them was Mr. J. Fergus-

---

<sup>1</sup> Particulars supplied by the Meteorological Office.

## SUMMARY OF RESULTS.

Districts	Names of Stations	Percentages				Total Percentage of Success
		Complete Success	Partial Success	Partial Failure	Total Failure	
Scotland, N.	Munlochy and Golspie	52	35	8	5	87
Scotland, E.	{ Aberfeldy, Glamis, and Rothiemay }	53	42	5	—	95
England, N.E.	Chatton and Ulceby	57	31	10	2	88
England, E.	Rothamsted and Thorpe	54	32	13	1	86
Midland Counties	Cirencester and East Retford	50	42	6	2	92
England, S.	{ Reading, Maidstone, Down- ton, and Horsham }	52	42	6	—	94
Scotland, W.	{ Stranraer, Islay, and Dum- barton }	60	28	12	—	88
England, N.W.	Leyburn and Prescot	47	38	12	3	85
England, S.W.	{ Tortworth, Clifton, Bridgend, and Glastonbury }	52	36	11	1	88
Ireland, N.	{ Moynalty and Edgeworths- town }	55	37	5	3	92
Ireland, S.	{ Tralee, Kilkenny, and Par- sonstown }	50	37	9	4	87
Mean for all districts		53	36	9	2	89

son, of Thetford, who remarks: "They (the forecasts) have been only too true." Sir Richard Paget, of Shepton Mallet, says: "As a general rule they have been absolutely correct, and only very occasionally has there been a slight error in direction of wind."

## SOME RELATIONS OF BIOLOGY TO AGRICULTURE.

At the formal opening of the new building of the Biological Department of the University of Toronto, advantage was taken of the occasion to bring together some of the distinguished biologists of the North American Continent, each of whom delivered an address upon that branch of biological research with which he was most familiar. The intimate relationship between biology and agriculture was aptly illustrated in several of the addresses, particularly in the three dealing respectively with Pathology, the Sporozoa, and Scientific Work.

*Pathology as related to Biology.*—Dr. W. H. Welch, professor of pathology in the Johns Hopkins University, Baltimore, dealt with

pathology in its relations to general biology. He defined biology as the study of life in all its forms and activities, both normal and abnormal. No branch of knowledge can exceed this in interest and importance ; none has made greater advances during this century of scientific progress. Pathology is that section of biology which deals with the study of life in its abnormal forms and activities. It embraces the investigation of the causes of disease, of the anatomical changes produced by disease in the organs and tissues of the body, and of the alterations in function resulting from disease ; it therefore constitutes the scientific basis of practical medicine. Preventive and curative medicine is constantly making beneficent applications of pathological discoveries, and the most intelligent and efficient treatment of disease is becoming more and more that which is founded upon the most accurate knowledge of its nature and causes.

As an illustration of the achievements of modern pathology, it is instructive to contrast the imperfect, meagre, and confusing information of former times with the extent of our present knowledge concerning one of the greatest of disease-scourges—tuberculosis. Merely a few years ago, not only was the specific cause of tuberculosis unknown, but there was no general appreciation of the fundamental fact that this is one of the infectious diseases. The knowledge of the frequency, and wide distribution, of tuberculous disease in other parts of the animal body than in the lungs is an acquisition of modern pathology. The pathological anatomy of tuberculosis, which not long ago was one of the most confusing chapters in pathology, has been made clear. The greatest addition to our knowledge of tuberculosis, and, in fact, one of the greatest achievements of modern science, is the discovery of the specific living germ which causes the disease in question. It is now practicable to study, both within and without the body, the form and properties of this germ, as well as the conditions which are favourable and those which are hostile to its preservation and development.

The points of contact between animal and vegetable pathology are more numerous than might at first glance appear. The student of animal pathology can draw many instructive lessons from such subjects as the behaviour of wounds and parasitic affections in plants. Too much, perhaps, is made of the separation between the pathology of man and that of the lower animals. While there is a wide distinction in the dignity of the object of study, yet, from a scientific point of view, this separation is of little account. Pathological investigations of the diseases of animals constitute no less genuine and valuable contributions to pathology in general than do similar investigations of human diseases. The advancement in recent years in the education and aims of those who devote themselves to the study of animal pathology will serve to bring into closer relationship the students of human and those of comparative medicine. Insistence is laid on the fact that the pathologist, whose sole knowledge of such a disease as tuberculosis is derived from the study of the disorder as it occurs in man, has a far less complete understanding of it



than one who is familiar with the striking peculiarities of this affection in cattle, sheep, swine, fowls, and other animals.

Especial importance necessarily attaches to the study of such diseases as are communicable from animals to man, as, for instance, glanders, anthrax, tuberculosis, many entozoic affections, &c. ; and, in general, these are the animal diseases which have received the most attention from students of human pathology. The experimental production of diseases in the lower animals affords an insight, to be gained in no other way, into the causes, development, lesions, and functional manifestations of many disorders. Experience, however, has shown that grave errors are likely to be committed by experimental pathologists who have no knowledge of the natural diseases and conditions of the animals used for experimentation. Often, for example, those studying the question of experimental tuberculosis have mistaken for genuine tubercles the nodules produced by parasitic entozoa, and have thus been led to form misleading conclusions.

An important and promising field of pathological study is to be found in the infectious diseases of animals and of plants, not only on account of the great economic interests often involved, but also because it affords a means of widening and deepening our conceptions as to the causes, development, prevention, and treatment of infectious diseases in general. Any pathologist who is at all familiar with the remarkable and peculiar conditions, under which the so-called Texas cattle fever of the United States develops and spreads, will realise that the complete elucidation of all the etiological factors of this disease would not only contribute to the solution of a great economical problem, but would also open fresh points of view in our conceptions of infectious agents and their properties. It is not a small thing that questions which were once considered to be wholly transcendental, as, for instance, the doctrine of immunity against infectious diseases, should have been brought within the working domain of experimental pathology. The interesting studies of heredity by Weismann and others pertain in part to pathology, and also illustrate forcibly the value of the comparative method of research.

*The Sporozoa.*—In discussing the pathogenic (*i.e.* disease-producing) Sporozoa, Professor Ramsay Wright, of the University of Toronto, stated that the Sporozoa are a group of low forms of animal life, belonging to the sub-kingdom Protozoa, which, in consequence of the universal adoption of a parasitic mode of life, possess certain peculiarities of structure and reproduction which mark them off quite sharply from the rest of the sub-kingdom. The structural peculiarities consist chiefly in the absence of any specialised organs for locomotion, or for the ingestion of food, whilst the reproductive peculiarities are found in the formation of large numbers of characteristic spores—whence the name Sporozoa, given by Leuckart. They are all unicellular animals, occasionally so large as to be visible to the unaided eye, but often—especially those of pathological interest—quite microscopic. Four orders are distinguished: (1) Gregarinidia, (2) Sarcosporidia, (3) Myxo-

sporidia, (4) Microsporidia. It should be clearly understood that these organisms are in no way related to the Bacteria.

The Gregarinidia are best known in the form of minute worm-like parasites in the intestines of insects and other invertebrate animals. The Sarcosporidia (*sarx*, flesh) are so named from the circumstance that they are generally found in the muscular tissues of vertebrate animals. They have long been known in the flesh of pigs, sheep, and other animals, where they may occur in considerable numbers without apparently affecting the health of their host. When present in large numbers, however, they may give rise to various symptoms, according to the group of muscles involved. They are, moreover, not confined to the muscular fibre, for they occur in the connective-tissue of the œsophagus (or gullet) of the sheep, forming there tumours of considerable size. The third order is not of agricultural interest. The Microsporidia include organisms, the spores of which are so small that they have been mistaken for Bacteria. They occur as parasites of the tissue-elements of insects, and, in the form of the pebrine of the silkworm, have led to enormous losses in silk culture in Europe. M. de Quatrefages calculated that, in the first thirteen years after the outbreak of pebrine, France lost 40,000,000*l.* from the ravages of this sporozoon.

Of the Gregarinidia there is a group, the Coccidia, which are true cell-parasites, though a brief free, or wandering, stage in their career permits the young forms to invade new cells or new hosts. The best known is *Coccidium oviforme*, from the liver of the rabbit. It occurs in caseous nodules and cysts of the liver, which are full of the parasites in their encapsuled stage (the so-called psorosperms). Several cases are recorded in which man has been attacked by the same parasite, and in one instance twenty cysts full of coccidia were found in the liver. There seems to be little doubt that cysts of this nature, full of caseous material, have often been misinterpreted in the past, and closer attention in the future may establish that such psorospermiosis of the liver is not so rare as has been supposed. The epidermal cells of the skin are also subject to attacks of Coccidia, and Pfeiffer has given a detailed account of the forms which cause a contagious skin-disease in poultry, and which were originally described by Bollinger in 1873. The cells are invaded by the Coccidia, and their nuclei are thrust aside as the parasite grows and proceeds to sporulation. The spores are at once capable of propagating the disease, which, therefore, may be artificially produced by inoculation—and, indeed, if planted on the mucous membrane of the throat, instead of on the skin, the spores take on a flagellate, instead of an amœboid, form, but penetrate the epithelial cells and give rise to a diphtheritic condition, which is very contagious amongst the poultry exposed to infection. *Molluscum contagiosum* and certain other forms of skin-disease in the human subject are likewise attributed to Coccidia, and it is probable that these organisms will be proved to have a close relationship to the development of cancer. Scheurlein's bacillus of cancer has turned out on examination to have nothing to do with the disease.

Perhaps the most interesting of all the Sporozoa are those forms which invade the blood-cells and, by the disintegration of these, lead to serious disease. Such forms have been found in India in the blood of mules suffering from an epidemic pernicious anæmia, the so-called Surra-disease. The comparative parasitology of the blood is, however, yet in its infancy. Enough has been said to show that not only Bacteria, but low forms of animal life, furnish important pathogenic organisms, and that continued comparative researches on the whole group of the Sporozoa are required to fill up the gaps in our knowledge of those forms which are pathogenic to domesticated animals.

*Encouragement of Scientific Work.*—Dr. Victor C. Vaughan, professor of bacteriology in the University of Michigan, dwelt on the necessity of encouraging scientific work. "Science is knowledge; art is the application of knowledge. Science consists of facts; art utilises these facts. Science investigates; art adapts. Science is the foundation; art is the superstructure. Science is the mariner who sails out over the seas of ignorance, and discovers fair islands and broad continents of truth; art is the immigrant who comes later, and tills the soil, and builds the cities."

All living things consist of individual parts called cells. Some of the lowest forms of life are simple free cells, and are termed unicellular. In such cases, this single cell must perform all the vital functions. It must digest, absorb, excrete: but its range of functions is necessarily limited. In ascending the scale of organised life, a multiplication and differentiation of cells becomes noticeable. In the higher animals certain cells have for their sole function the elaboration of the digestive juices, others are employed in the separation of effete and poisonous matters from the blood and their elimination from the system, and so on. Health is maintained by the proper and correlative activity of these various groups of cells.

Within the last fifteen years it has been clearly demonstrated that the introduction of some of the lower forms of vegetable life, called Bacteria, into the body of man and other animals produces disease. The study of these micro-organisms has brought into existence and developed the science of Bacteriology. A large amount of information has already been accumulated in this field of scientific work, so that the art of the preservation of health—hygiene—and the art of restoration to health—medicine—have benefited by many valuable practical applications of these scientific facts. There are numerous problems to be solved concerning Bacteria. What chemical alterations do they cause in the various media in which they grow? What fermentations do they induce? Why is it that an alteration in the environment so materially affects the virulence of some of them? Why is it that the bacillus of anthrax is so invariably fatal to certain animals whilst others enjoy perfect immunity against the same germ?

Two factors enter into the causation of infectious disease. First,

there must be susceptibility in certain cells of the body ; secondly, the inciting cause is the specific micro-organism. Indeed, it might be said that the primary cause lies in the tissue itself. Then there is the ever-interesting subject of immunity against disease secured by the use of sterilised culture of the various specific micro-organisms. Is such immunity, which has already been obtained in a number of diseases, due to a true vaccination, or is it simply due to the establishment of a tolerance for a poison ? How long will the immunity thus secured continue ?

The study of food and drink by the bacteriologist has only begun. In many of the infectious diseases the specific poison finds its way into the body through the mouth. The chief source of infection with cholera in India is the drinking-water, which is collected during the rainy season in tanks that not only serve the inhabitants for water-supply, but are also used as laundry and bath tubs. And, in the western world, many towns discharge their sewage into bodies of water from which they or other communities derive their supply for drinking purposes. The risk of seriously affecting the health, by eating food which has partially undergone putrefactive changes, increases every year with the growing consumption of canned and otherwise preserved food.

Every important scientific discovery sooner or later finds its practical application. What could have been more unpromising of practical results than the discovery by Pollemler, in 1849, of micro-organisms in the blood of an animal sick with anthrax ? When this observer reported that he had seen minute forms of life in the blood, some said that the objects were bits of fibrin, others that they were not real at all but due to defects in the glass, while still others hinted very strongly that the defects really existed in the observer's brain ; but truth prevailed, and from that observation, or discovery, as a starting-point, the science of Bacteriology has been developed to its present importance, and, by virtue of the facts underlying this science, the spread of infectious diseases has been checked in a manner that would never have been thought of in the past. It was owing to knowledge, founded upon the discovery under notice, that Asiatic cholera was arrested in New York harbour in 1888, and prevented from spreading through the United States and Canada.

W. FREAM,

---

## RECENT AGRICULTURAL INVENTIONS.

*The subjects of Applications for Patents from March 16, 1891, to June 6, 1891.*

N.B.—Where the Invention is a communication from abroad, the name of the Inventor is shown in italics, between parentheses, after the name of the applicant.

**Agricultural Machinery and Implements, &c.**

No. of Application.	Name of Applicant.	Title of Invention.
4651	BARRETT, C. F.	Save-all or carrier for reaping-machines.
4741	BICKERTON, R. & R. B.	Distributors for seed sowing.
4742	BLUNT, A. H. P.	Collecting and loading hay.
4937	BOULT, J. A. ( <i>Moxon</i> )	Seeding-machines.
4944	BOULT, A. J. ( <i>La Pierre</i> )	Seed-sowing-machines.
4946	KING, A.	Forks and hoes.
5984	TAYLOR, J. L.	Self-cleaning garden-rake.
5179	EDWARDS, W.	Sowing grain.
5206	TODD, F. E.	Sheaf-binding harvesters.
5477	ZILLWOOD, A.	Reaping and mowing-machines.
6966	LAKE ( <i>Reynolds</i> )	Hay tedders.
6074	HORN, W. W. ( <i>Schuett</i> )	Dividers for mowing-machines.
6109	LAMPITT, C.	Separating, &c., barley, &c.
6576	SLEEP, W. H. & R. H.	Ploughs.
6652	LEE, J. H.	"
6653	LEE, J. H.	Disc-harrows.
6666	COTTIS, C.	Horse-hoes.
6776	BIRO, E. and another	Hay-knife.
6842	BOULT ( <i>Moxon</i> )	Seeding-machines.
6844	THOMPSON ( <i>McKay</i> )	Plant-setters and seed-planters.
6891	FLOAT & GOWERS	Chaff cutters.
7930	GULLAN	Gathering corn, &c.
7012	MARSHALL, J.	Potato-diggers.
7102	MANTLE, A. W.	Mowers.
7196	BARKER, W. H.	Harvesting-machines.
7847	AHNER, H. A.	Machine for uprooting weeds, &c.
8187	DRAYDON and others	Turnwrest-ploughs.
8236	ROBERTS, H.	Hay and straw elevators.
8247	EDWARDS, J. R.	Elevators for hay, &c.
8553	BOULT ( <i>Severance</i> )	Sheaf-binding harvesters.
8737	WILLIAMS, R. H.	Ploughs.
8750	GIBBS, H. W. ( <i>Tassio</i> )	Threshing-machines.
8788	COOMBS, E. T.	Harrows.
8931	HAILEY, H.	Horse-hoes.
8996	CHANDLER, T. H.	Seed-drills.
9099	NICHOLSON, W. N.	Horse-rakes.
9111	ATTERTON & TILBROOK	Corn and seed-drills.
9141	HORN, W. W. ( <i>Selliss</i> )	Hay-racks or ladders.

No. of Application.	Name of Applicant.	Title of Invention.
9195	TIMMIS, R. . . .	Canvasses of sheaf-binders.
9302	WOOLDRIDGE, E. . . .	Potato-planter.
9322	NORTON & MITCHELL . . . .	Sheaf-carriers of reaping-machines.
9364	HUXTABLE, J. . . .	Horse-rakes.
9406	TIMMIS, R. . . .	Reaping and mowing-machines.
9455	THOMPSON, W. P. ( <i>Gayon</i> )	Spades, hoes, &c.
9586	TIMMIS, R. . . .	Securing ends of canvas in sheaf-binders, &c.
9588	WEIR, C. . . .	Carriers for hay, &c., crops.

### Stable Utensils and Fittings—Horse-shoes, &c.

4999	TEMPERLEY, J. . . .	Saddles.
5097	TOZER, A. . . .	Harness and stable fittings.
5117	WOODMAN & JENKINS . . . .	Safety saddle-bars.
5148	FINCH, T. F. . . .	Horse-shoes.
5152	SCHULZ & STAHLCKER	Curry-combs.
5176	BAYLIS, J. H. . . .	Horse-shoes.
5186	PANZER, C. A. . . .	Safety stirrup.
5459	BROWNE-CAVE, R. H. C.	Ointment for splints, curbs, &c.
5471	WOODMAN & JENKINS . . . .	Stirrups.
5512	VON EULENFELD . . . .	Tightening device for saddle-girths.
5516	WITTEY, G. C. . . .	Horse-shoes for asphalt pavements.
5541	CHART & DUFF . . . .	Combined nailed or nailless horse-shoe.
5686	RUSSELL & DOWNING . . . .	Saddles.
5762	WARD & HURMAN . . . .	Nose-bag for horses, &c.
5964	EASTON, H. . . .	Driving-reins.
6095	PROCTOR & HARTLEY . . . .	Horse-shoes.
6176	HOLDSWORTH & BULLARD	Slipless horse-shoes.
6209	BRIGGS & PRIESTLEY . . . .	Nailless horse-shoes.
6239	FISCHER, C. L. . . .	Quickly unharnessing fallen horses.
6523	BROWN & FRANKLIN . . . .	Horse-clipping machine.
6720	PAGE & MACDONALD . . . .	Attaching horses to mangers.
6739	HORN, W. W. ( <i>Fosker &amp; Church</i> ) . . . .	Riding-saddle.
6875	LOGAN, M. . . .	Drain for stable-stalls.
7017	CLIFFORD, S. E. . . .	Bits for bridles.
7021	TRENCH, F. C. . . .	Saddle-girths.
7029	FATHERS, T. H. . . .	Portable shoeing-forge for stable use.
7111	JUTSON & POUPARD . . . .	Nailless horse-shoes.
7176	MCGILLIVRAY, J. . . .	Horse-shoes.
7439	TAYLOR, G., and another . . . .	Horse-shoes.
7503	CORMONT, C. F. H. . . .	Harness.
7621	GREENHALGH, A. . . .	Saddles.
7611	CONNELL, J. C. . . .	Harness.
7642	MENDEL, A. . . .	"
7681	CANNON, T. M. . . .	Administering medicines to horses, &c.
7844	RIMINGTON, M. F. . . .	Saddles.

No. of Application.	Name of Applicant.	Title of Invention.
8321	JACKMAN, J. . . .	Measuring the withers and backs of horses.
8411	HENSHAW, T. S. ( <i>Avit</i> ) . . .	Stopping runaway horses.
8451	VON BRIESEN, O. . . .	Controlling restive and runaway horses.
8465	HOLDSWORTH & BALLARD . . . .	Bits and reins.
8683	BARBER-STARKEY, . . .	Safety stirrups,
8741	LARDONNOIS, N. A. . . .	Quickly harnessing, &c., horses.
8773	BURTON, J. . . .	Horse-shoe to prevent slipping.
8828	ZACHARIAS, J. . . .	Ventilating horse-clothing.
9088	WINCER, C. . . .	Harness saddles.
9619	CAWDLE, T. H. . . .	Horse-clothing.
9649	GREEN, F. W. & SWAN, G. A. . . .	Harness attachments for road vehicles.

### Carts and Carriages.

4974	DOYLE, T. W. . . .	Adjustable safety device for vehicles.
5312	FRANCE, D. . . .	Carts and other two-wheeled vehicles.
6595	BOULT, A. J. ( <i>Gelhar</i> ) . . .	Vehicle brakes.
6996	MURGATROYD, E. . . .	Carts, carriages, &c.
9048	COGAN, F., and others . . .	Lighting vehicles by electricity.
9150 9151	} DAWSON, P. . . .	Brakes or skids for waggons, carts, &c
9324		
9506	HILL, N. H. . . .	Carts.

### Dairy Utensils, &c.

6241	WISE ( <i>Jonsson</i> ) . . . .	Centrifugal milk separator.
6250	LAKE ( <i>Nilsson</i> ) . . . .	Facilitating the milking of cows.
7318	SPIES, A. . . .	Churns.
7638	EYBE, J. W. & GRAHAM . . . .	Securing milk cans to doors.
7828	DUNN, J. . . .	Moulding butter and forming into pieces of given size and weight, &c.
7995	MITCHELL, W. . . .	Milking machine.
8056	WILLIAMS, W. . . .	Cheese cutter.
8240	HORN, W. W. ( <i>Wood</i> ) . . .	Cooler and strainer for milk.
5002	WALTERS, W. B. . . .	Pneumatic churn.
5019	WISE, W. L. ( <i>Walters</i> ) . . .	Churns.
8977	WELLMAN, E. S. T. . . .	Driving churns.
9011	THOMPSON. ( <i>L'Huillier</i> ). . .	Churns.
9422	LARSEN, A. C. . . .	Milk separators.
9534	JENKINS, A. . . .	Metal seal for milk cans.
9547	SHIELDS & ELLIOTT. . . .	Teats for milking machines.

### Poultry and Game, &c., Appliances.

4737	MARSDEN, T. . . .	Appliance for feeding birds.
4747	GARDINER, A. . . .	Exhibition and travelling pen.
5380	MARSHALL, J. B. . . .	Preserving eggs.

No. of Application.	Name of Applicant.	Title of Invention.
6123	MEAD, W.	. Poultry coop.
6473	HATHWAY, J.	. Apparatus for carrying eggs,
8110	CASHMORE, C.	. Treating eggs in incubators.
8779	HUNTER, R.	. Pheasant coops.
8954	PATON W. J. G.	. Heat regulator for incubators.

**Miscellaneous.**

5306	WILMOT, A. T.	. Beehive.
5317	BURGON, C. & H.	. Shearing or clipping sheep, &c.
6015	ROBINSON, G. & BADGER, A.	. Securing horses, cows, &c.
6255	DUNN, J. & W.	. Cattle-food.
6704	HORNER, L. M.	. Dog kennels.
7011	MCDONALD, A.	. Tethers.
7165	BONNE, C. R.	. Measuring, &c., supply of oats to cattle.
7249	DAY, J. H. & A. S.	. Drenching bottle.
8315 } 8476 }	RIPLEY, R.	. Dog-muzzles.
8789	MUNNS ( <i>Chapman</i> )	. Apparatus for watering stock.
9527	YATES, T.	. Combined sheep-rack and manger.

**Numbers of Specifications relating to the above subjects Published since March 14<sup>1</sup>**

(with prices in parentheses).

## Specifications of 1890.

3862 (*4d.*), 3988 (*6d.*), 4330 (*6d.*), 4376 (*6d.*), 4461 (*8d.*), 6319 (*6d.*), 6532 (*6d.*), 6551 (*8d.*), 6717 (*6d.*), 6767 (*6d.*), 6792 (*6d.*), 7064 (*6d.*), 7377 (*11d.*), 7539 (*8d.*), 7588 (*6d.*), 7652 (*8d.*), 7746 (*6d.*), 7778 (*6d.*), 7779 (*6d.*), 7813 (*8d.*), 8014 (*6d.*), 8041 (*8d.*), 8342 (*8d.*), 8323 (*6d.*), 8596 (*1s. 1d.*), 8650 (*8d.*), 9455 (*8d.*), 9487 (*8d.*), 9804 (*8d.*), 9955 (*8d.*), 10411 (*6d.*), 11437 (*8d.*), 12648 (*8d.*), 16412 (*11d.*), 17174 (*8d.*), 20423 (*4d.*), 20700 (*6d.*), 20652 (*6d.*), 21081 (*6d.*), 21223 (*6d.*), 21146 (*6d.*), 21298 (*6d.*).

## Specifications of 1891.

959 (*8d.*), 1316 (*6d.*), 1187 (*6d.*), 1499 (*6d.*), 2291 (*6d.*), 3506 (*6d.*), 3598 (*6d.*), 3808 (*6d.*), 4153 (*6d.*), 5186 (*6d.*), 5249 (*11d.*), 5317 (*8d.*), 5512 (*6s.*), 6319 (*6d.*), 6473 (*6d.*).

<sup>1</sup> Copies may be obtained at the Patent Office (Sale and Store Branch), 38 Cursitor Street, London, E.C.



JOURNAL  
OF THE  
ROYAL AGRICULTURAL SOCIETY  
OF ENGLAND.

---

THE DONCASTER MEETING, 1891.

IN selecting Doncaster as the place of its Country Meeting for 1891 the Royal Agricultural Society entered upon new ground, never having hitherto met within thirty miles of this famous centre in South Yorkshire. It was, however, not the fault of Doncaster that more than half a century should have elapsed since the birth of the Society before it had an opportunity of welcoming "the Royal" within its borders, for as long ago as 1848 it was one of half-a-dozen towns which extended an invitation to the Society on the occasion of its first visit to the county of broad acres—an invitation that was repeated in 1861, when Leeds was the successful competitor.

The Society has met on four previous occasions in Yorkshire—at York in 1848, under the presidency of the second Earl of Yarborough; at Leeds in 1861, under the presidency of the late Earl of Powis; at Hull in 1873, under the presidency of Earl Cathcart; and at York, for the second time, in 1883, under the presidency of the Duke of Richmond and Gordon, K.G.

THE SHOW-GROUND.

An extent of 80 acres of almost level ground upon Doncaster Town Moor afforded an admirable site for the showyard. As will be seen from the plan on page 443, the ground occupied a portion of the area surrounded by the racecourse, whilst the entrances

were opposite the permanent Grand Stand. An extensive sweep of greensward just within the entrance gates effectually prevented any congestion of traffic. In laying out the ground the Surveyor had utilised to the full the natural facilities which were at his disposal. The main central avenue was flanked on either side by two lateral avenues, so that on entering the yard the visitor had before him a choice of five distinct routes past the implement shedding to the live-stock departments at the farther part of the ground.

The showyard was about a mile from the town, and the high road between Doncaster and the Town Moor—probably one of the best-known roads in England—left an agreeable impression upon the minds of those who travelled it. The trees which border it were in the prime of their foliage, the roadway was maintained in excellent condition throughout the week, and the broad footpaths enabled it to be devoted exclusively to wheel traffic.

#### PRIZES AND ENTRIES.

Situated in the heart of the horse-breeding country, it was anticipated that Doncaster would attract a great show of horses; and this expectation was amply realised. The number of horses entered, 717, was considerably more than double the number in the Plymouth catalogue last year. The sections which stood out conspicuously in point of numbers were the Hunters, the Shires, and the Hackneys. The Shires, indeed, were catalogued in almost the identical number by which they were represented at the Jubilee Show at Windsor, in 1889.

The locality in which the Show is held must necessarily exercise an influence in determining the specific breeds of live-stock amongst which competition shall, year by year, be invited. In comparing, in this respect, the Doncaster Meeting with its immediate predecessor, there is no change to be noticed in the horse sections. With cattle and sheep, however, it is different, and the Southern breeds specially provided for at Plymouth had to give place to Northern breeds at Doncaster. The cattle sections common to the two Meetings were the Shorthorns, Herefords, Devons, Sussex, Welsh, Red Polled, Jersey, Guernsey, Kerry, Dexter, and Dairy Cows. But the locally developed South Devon (or South Hams) cattle, classed at Plymouth, could obviously claim no place at Doncaster. On the other hand, certain of the Scotch breeds—the Aberdeen Angus, the Galloway, and the Ayrshire—to which Plymouth would have been *Ultima Thulé*, appropriately enough found a place at a Meeting held north of



the spot to which Prince Charles Edward penetrated with his ill-fated army a century and a half ago.

The influence of locality becomes more emphasised in the case of sheep. Such longwools as the Leicester, the Cotswolds, and the Lincolns, and such shortwools as the Oxfords, Shropshires, Southdowns, Hampshires, and Suffolks, follow "the Royal" wherever it goes. These, at Plymouth, were supplemented by the "Horns" of Somerset and Dorset, the Devon Longwools, the South Devons, the Dartmoors, and the Exmoors, all of which were absent at Doncaster. In their place, however, visitors enjoyed the opportunity of inspecting nearly 150 pens variously occupied by Wensleydales, Border Leicesters, Cheviots, Black-faced Mountain Sheep, Lonks, and Herdwicks.

#### A RETROSPECTIVE GLANCE.

It is instructive to glance back at the last Yorkshire Meeting, held in the city of York eight years previously. On that occasion, in both the Shorthorn and the Hereford sections, family classes were added. The Red Polled cattle appeared under their old name of "Norfolk and Suffolk," whilst the Aberdeen Angus cattle were catalogued as Polled Angus or Aberdeen. No classes were provided for Guernsey, Kerry, and Dexter cattle. Of sheep, the Lonks, the Herdwicks, and the Suffolks had no distinctive place in the catalogue, and had to seek refuges amongst the "Other Long Wools" or the "Other Short Wools," of which there were male and female classes of each. In the pig sections, the Tamworths enjoyed no separate classification in 1883, but they figured in the prize list for "Any Other Breed." There were no feathered exhibits at York, whilst the cheese and butter competitions possessed in a high degree the merit of simplicity. There was merely one class for each, the former for a half-hundredweight of Yorkshire cheese of any make, the latter for six pounds of fresh butter. A working dairy found no place in the programme, and there was no provision either for butter-making competitions or for horse-shoeing contests. Classes for cider and perry, and for jams and preserved fruit, were likewise unprovided eight years ago.

In the Implement Section prizes were this year offered for combined portable threshing and finishing machines; for cream separators, both hand and power; and for mechanical milking machines. In 1883, the only competition in this department was for the best equipped dairy, suitable for not more than 20 cows. This year 94 implements were entered as "new," with the object

of securing the Society's Silver Medal. This medal was awarded for (1) an improvement in a weighing-machine for cattle, (2) a manure distributor, (3) an improvement in a cream separator, (4) a milking machine, and (5) a sheaf binder. In 1883, nine medals were severally awarded for a butter worker and table combined, a straw trussing machine, a straw yealming machine, a steam plough, a wire rope for steam cultivation, a horse hoe, a corn screen, a threshing machine, and a dredger.

Subjoined is a statement of the entries at the Doncaster Meeting, together with those of the preceding eight years, including the Show held at York in 1883:—

Number of animals entered	Doncaster, 1891	Plymouth, 1890	Wind-sor, 1889	Nottingham, 1888	Newcastle, 1887	Norwich, 1886	Preston, 1885	Shrewsbury, 1884	York, 1883
Horses . . .	717	333	996	546	500	493	438	407	611
Cattle . . .	669	642	1,644	644	626	681	539	579	462
Sheep . . .	649	571	1,109	537	513	446	433	490	412
Pigs . . .	205	223	265	143	194	203	203	211	200
<b>Total . . .</b>	<b>2,240</b>	<b>1,769</b>	<b>4,014</b>	<b>1,875</b>	<b>1,833</b>	<b>1,823</b>	<b>1,613</b>	<b>1,687</b>	<b>1,685</b>
Poultry . . .	783	695	861	343	405	191	325	—	—

Shedding in Implement Yard (in feet) [exclusive of open ground space]	Doncaster, 1891	Plymouth, 1890	Wind-sor, 1889	Nottingham, 1888	Newcastle, 1887	Norwich, 1886	Preston, 1885	Shrewsbury, 1884	York, 1883
Ordinary . . .	8,343	6,117	10,378	7,253	5,508	7,155	8,417	9,315	9,569
Machinery in motion . . .	2,106	1,291	2,496	1,607	1,125	2,017	2,063	2,035	1,949
Special shedding (including seeds, models, &c.)	2,024	1,670	2,728	1,883	1,584	1,640	1,520	1,554	1,618
<b>Total . . .</b>	<b>12,473</b>	<b>9,078</b>	<b>15,602</b>	<b>10,743</b>	<b>8,217</b>	<b>10,812</b>	<b>12,000</b>	<b>12,904</b>	<b>13,136</b>

### THE SHOW.

The Implement Department was open to the public on Saturday, June 20, and the entire yard from Monday, June 22, to Friday, June 26. The Saturday was extremely hot and brilliant, and during the day most of the entries of live-stock arrived and took up their allotted places. The weather record of the Meeting was decidedly satisfactory. Sunday morning was dull and overcast, but gave place to a delightful afternoon and evening. Monday, the judging day, was cool and cloudy, with an occasional burst of sunshine, followed by a light fall of rain late in the afternoon. Tuesday morning was fine, but heavy rain began to fall between 2 and 3 P.M., and continued for the remainder of the day—fortunately, it commenced too

late to seriously interfere with the attendance of the paying public. The three remaining days—Wednesday, Thursday, and Friday—were bright and pleasant.

On the Sunday the usual custom was followed of holding Divine Service on the Showground. It commenced at 11 A.M., by which time the large marquee was filled to overflowing, the attendance being computed at about 800. The Rev. Canon Tebbutt, M.A., vicar of Doncaster, officiated, and preached an eloquent sermon from the text (Genesis xlvii. 3), "What is your occupation?"

Business commenced in earnest on the Monday morning, when, at an early hour, the Honorary Director, Sir Jacob Wilson, met the Stewards and the Judges of live-stock, and, having briefly indicated the course to be followed, dismissed these gentlemen to their respective duties. The attendance was larger than usual for the five-shilling day, and this led to the various judging rings being well patronised by visitors, who manifested keen interest in the proceedings, and in the announcement of the awards.

On Tuesday the general meeting of members took place on the ground; the chair being occupied by the Earl of Ravensworth, President of the Society. A report of the meeting is given in the Appendix, page xciii. The band of the Yorkshire Dragoons occupied the band-stand on this and the remaining days of the Show, and played selections of music at intervals. The performances were remarkably good, and proved to be highly popular.

On the evening of the same day the Mayor of Doncaster (Alderman Charles Stockil), to whose cheery and ever-ready assistance much of the success of the Meeting was due, gave a banquet at the Mansion House, Doncaster, to the Council and officers of the Royal Agricultural Society. The Mayor, who occupied the chair, having submitted the loyal toasts, proposed that of "The Army, Navy, and Reserve Forces," to which Earl Cathcart responded. The toast of "The Royal Agricultural Society of England," also proposed from the chair, was, in the absence of the Earl of Ravensworth, acknowledged by the Earl of Feversham, the President-elect of the Society. Before resuming his seat his Lordship proposed the health of the Mayor, with hearty acknowledgments of great kindness and generous hospitality. The toast of "The Town and Commerce of Doncaster" was proposed by Sir Jacob Wilson. Alderman Smith, in responding, made allusion to the markets of Doncaster, and to the importance of the town as an agricultural centre.

Wednesday, June 24th, was the red-letter day of the Don-

caster Meeting, being that selected for the royal visit. Their Royal Highnesses the Prince and Princess of Wales were staying at Wentworth Wodehouse as the guests of Earl Fitzwilliam, and with their noble host and a large house party they drove on to the Showground at noon. Lord Fitzwilliam's yellow carriages turned out in the old style, four-in-hand, with numerous outriders and mounted men; and the effect of the procession along the central avenue was heightened by the brilliancy of the midsummer sunshine. Luncheon was laid in the Royal Pavilion, which formed so beautiful and conspicuous a feature in the middle of the Showyard. The parade of live-stock in the great ring was excellently arranged, particularly that of the cattle, and was the subject of general admiration. The royal party, which included the Duke of Clarence and Avondale and the Princesses Victoria and Maud of Wales, did not leave the ground till after four o'clock.

The "people's day"—as fine a day, fortunately, as could have been wished—was Thursday, when 57,580 people paid 1s. each for admission. This number, large as it was, fell short of the number on the corresponding day at York in 1883, and was very decidedly below the corresponding numbers at Newcastle in 1887 and at Nottingham in 1888.

The charges for admission were those which have usually been adopted during recent years—2s. 6d. on the Implement Day, 5s. on Monday, 2s. 6d. on Tuesday and Wednesday, and 1s. on Thursday and Friday. The experiment, tried at Plymouth, of having three 1s. days and only one 2s. 6d. day, was not repeated.

As will be gathered from an inspection of the subjoined table, the aggregate attendance of paying visitors at Doncaster occupies a fair average position amongst the totals of recent years. It must be remembered that at Doncaster there is no large local population to fall back upon. Had it been otherwise, it can hardly be doubted that the fine weather would have tempted the inhabitants of the neighbourhood to pass the turnstiles in their thousands, and thus to have largely increased the total attendance.

Day of Show	Don- caster, 1891	Ply- mouth, 1890	Wind- sor, 1889	Notting- ham, 1888	New- castle, 1887	Nor- wich, 1886	Preston, 1885	Shrews- bury, 1884	York, 1883
Implement day .	344	194	493	1,826	1,209	148	394	194	300
1st day (Mon.) .	2,681	1,234	6,223	1,671	1,097	625	3,557	2,183	3,012
2nd day (Tues.)	12,331	10,008	18,809	11,103	11,331	8,074	21,713	11,211	15,768
3rd day (Wed.) .	18,530	39,308	24,690	9,057	12,020	10,894	19,318	13,474	21,820
4th day (Thurs.)	57,580	32,371	32,965	88,832	77,410	42,774	34,302	49,374	63,097
5th day (Fri.) .	20,034	14,026	44,493	35,438	24,305	42,394	14,908	17,690	24,120
Total . . .	111,500	97,141	155,707 <sup>1</sup>	147,927	127,372	104,909	94,192	94,126	128,117

<sup>1</sup> Including 28,034 on the sixth day (Saturday).

In noticing below the various classes at the Doncaster Meeting, they are taken in the catalogue order. The views of the Judges of the respective sections are embodied, and, where necessary, quotations are given verbatim from the Judges' reports. The names of Stewards and Judges, with the complete list of Awards, will be found in the Appendix, page xcvii.

#### LIGHT HORSES.

*Thoroughbred Stallions.*—This was not a competitive class, being restricted to the three horses which won the three premiums of 200*l.* each, offered by the Society, and special Gold Medals provided by the Doncaster Local Committee, at the Spring Show, held at the Royal Agricultural Hall, London, March 3 to 6, 1891. They were Mr. Thomas Carr's *Crom-A-Boo*, foaled in 1881, bred by Mr. J. Ridley; Mr. David Cooper's *Linnæus*, foaled in 1878, bred by Mr. A. Harrison; and Mr. Edwin Hodge Banks's *Moss-Hawk*, foaled in 1880, bred by the owner. During the season of 1891, *Crom-A-Boo* stood at Ripon, and travelled the district; *Linnæus* stood at Bainesse, and travelled to Bedale, Northallerton, Scotch Corner, and Richmond; and *Moss-Hawk* stood at Driffield, and travelled the district.

*Hunters.*—This section was arranged in 11 classes, the same number as at the Windsor Meeting in 1889. Last year at Plymouth there were six classes. At Doncaster the classes were taken alternately by two sets of Judges, the one set dealing with Classes 1, 3, 5, 7, 9, 11; and the other set with Classes 2, 4, 6, 8, 10. For such a horse-breeding district, the display of hunters was disappointing, and the quality "did not come up to expectation, particularly in the younger classes."

Class 1, for hunter mare and foal, was good both in number and in quality. Mr. Frank B. Wilkinson's first-prize mare *Jessie*, a fourteen-year-old bay, with remarkably neat fore-hand, has a long showyard record. Next was placed Mr. Isaac D. Dunn's *Atalanta*, whose loins and quarters are faultless. Both these mares possess exceptional merit. Mr. Frederick Blenkin's *Princess Beatrice* was third.

Class 2, for hunter mare or gelding, up to 15 stone, foaled in 1885 or 1886, furnished some fine specimens of weight-carrying hunters, Messrs. Bennet and Martyn's first-prize gelding *Nimrod* "being especially a horse of merit."

Class 3, for hunter mare or gelding, up to 12 stone, foaled in 1885 or 1886, attracted a larger number of entries than any



other of the hunter classes. Nevertheless, although it included several useful horses, there was, with the exception of Mr. J. F. Laycock's first-prize bay gelding *Marquis*, nothing to call for special remark.

The four-year-old hunter geldings (Class 4) were deserving, taken as a whole, of special commendation. The place of honour was assigned to Mr. Andrew J. Brown's *Carrick*, the second and third prizes going respectively to Mr. Thomas Darrell's *Wyedale* and Mr. John Hadland's *Pilot*.

The four-year-old hunter mares (Class 5) made but a poor show, at the head of which was placed Messrs. Robinsons' bay mare *Gone Away*.

In Class 6, for three-year-old hunter geldings, Mr. Andrew J. Brown's first-prize winner, *The General*, "is a horse of exceptional merit, full of quality and strength, and a fine goer." The second- and third-prize winners, Mr. George H. Spraggon's *Rocket* and Mr. W. E. Lawson's *Blaze*, "show both quality and power."

The smallest of the Hunter Classes was Class 7, for three-year-old fillies. It was redeemed from mediocrity by the presence of Mr. James Martin's *Dorothy* and of Mr. Ernest Chaplin's *Phæbe*.

Hunter geldings foaled in 1889 (Class 8) made a good display, and, with few exceptions, were conspicuous for their growth. The substantial awards went, in order, to Mr. Thomas A. Cornthwaite's *Gamester*, Mr. Edmund Broumpton's *Marmion*, and Mr. G. A. Walker's *The Dane*.

In a commendable class of hunter fillies foaled in 1889 (Class 9), the prize-winners—Mr. W. Muzeen's *Modesty*, Dr. S. P. Budd's *Lady Scot*, and Mr. Rhodes Waterhouse's chestnut filly by Knight Templar—all promise to grow into valuable hunters.

Class 10, for hunter colts foaled in 1890, in which Mr. Frank B. Wilkinson's *The Curate* was first, "was very disappointing, and a long way below the average."

Class 11, for hunter fillies foaled in 1890, at the head of which was placed Mr. James Martin's *Mrs. O'Shea*, was likewise not satisfactory. "A want of bone and substance" was prominently noticeable.

Of the 33 prizes awarded in the Hunter Classes, 20 went to Yorkshire exhibitors, whilst two went to Nottinghamshire and two to Lincolnshire, nine other counties—Durham, Leicester, Middlesex, Norfolk, Northumberland, Somerset, Stafford, Warwick, and Westmoreland—securing one prize each. In Classes 1, 4, 5, and 10 all the prizes went to Yorkshire exhibitors.

*Coach Horses.*—These were shown in seven classes, as against

four classes at Plymouth in 1890. Class 17, for two-year-old coaching geldings, was, however, vacant, thus reducing the effective number to six classes. The display partook largely of a local character, so that, of the 17 prizes awarded, 16 went to Yorkshire exhibitors. All the prizes were offered by the Doncaster Local Committee.

Of coaching stallions foaled in 1886, 1887, or 1888 (Class 12), the Earl of Londesborough's *Prince Humbert* showed more quality than any of his competitors. Mr. George Burton's *Lord Risby* was second, and Mr. George Scoby's *Fortunatus* was third. The last-named is of "nice quality and well turned, but undersized."

Class 13, for two-year-old stallions, was the largest and the best of the Coaching Classes. No difficulty was felt in awarding the first prize to Messrs. W. and C. Harrison's *Sir James*. Mr. John Kirby's second-prize stallion *Kirby's Peacock* is a "nice level horse with fair action." Mr. Thomas Carr was third with *Salisbury*, "a very nice mover, and showed quality."

Class 14, for coaching mare and foal, made up in quality what it lacked in numbers. The first prize went to a grand stamp of mare in Mr. Thomas Kelsey's *Phyllis*, though she was closely pressed by Mr. F. J. Pettinger's *Recherché*. Mr. W. Parkin-Moore's *Lady Rosedale* took the third prize.

Of the three-year-old coaching geldings (Class 15), the Judges say that some would have made good stallions. Mr. John Kirby's *Elegance*, Mr. F. H. Stericker's *Criterion*, and Messrs T. and R. Richardson's *Grimston* were placed in the order indicated.

Three-year-old coaching fillies (Class 16) made a small but good display, at the head of which was placed Mr. John Kirby's *Lady Mary*. Of fillies foaled in 1889 (Class 18), Mr. John White's first prize, *Ainsty Pride*, "is full of quality, a fine mover, rather light on its back, and a trifle short in quarters." The second prize went to Mr. V. Prodhams's *Grateful*.

*Hackneys*.—The 128 entries in this section made an imposing display, especially when compared with the 33 entries which represented the breed at Plymouth. Of the 30 prizes awarded in the ten classes, Yorkshire took twelve, Sussex six, Norfolk four, Lancashire three, Nottinghamshire two, and one each went to Derby, Hunts, and Kent.

Two classes were allotted to hackney stallions foaled previously to 1889. In Class 19, for stallions above 15 hands, Mr. Richard Tennant's first-prize horse, *Connaught*, to whom was awarded the male championship, "is perhaps as good a type of a hackney sire as is to be found in the kingdom at the present

time." Mr. Frederick Childerhouse's *M.P.* worthily filled the second place, "but did not quite go with the same dash." Mr. Alfred Lewis's *Tip Top Shot* "is a very taking horse, but perhaps not quite of the same hackney type as the other two." In Class 20, for stallions above 14 hands and not exceeding 15 hands, Mr. John Henry Smith's *Sensation 6th* "is a young horse of great promise; he shows plenty of quality, has fine riding shoulders, and moves with plenty of freedom." It is a rare experience for Mr. Harry Livesey's *Evolution* to find himself in the second place, but the Judges were unanimous in giving the younger horse the precedence. Mr. Seth Lofthouse's *Lord Rattler* was third. This class, as a whole, "was only just a fair one."

Class 21, for hackney stallions foaled in 1888, was of moderate quality, and calls for no special comment. Mr. Henry Moore's *Caxton* was placed first.

Class 22, for stallions foaled in 1889, was regarded by the Judges as the best of the hackney stallion classes. It contained many animals of high merit, auguring well for the future of hackney breeding. The first prize went to Mr. F. Brough's *Enthorpe Performer*, "a beautiful horse full of quality, a fine all-round mover, and likely to develop into a hackney of the right type." He was placed in reserve for the male championship. The second-prize animal, Mr. Benjamin How's *Broughton Reality*, "is a colt with much substance and goes with great courage, and is adapted to do much good upon mares with quality." Mr. William Yeoman's third prize, *Romulus*, "is a fine slashing horse, and only wants time to fill in and make a very valuable animal." Five other horses in this class were noticed.

Class 23, for hackney brood mare and foal, above fifteen hands, was of superior quality. The prizes went, first to His Royal Highness the Prince of Wales for *New York*; second and third to Mr. Harry Livesey for *Countess* and *Lady Marton*—all high-class animals. Mr. Livesey's mares were of a type that the Judges preferred to the first-prize winner, but the exceptional movement of the Prince of Wales's mare secured her the first place. It may here be mentioned that His Royal Highness made as many as seven entries in the horse classes.

Class 24, for brood mare and foal, above fourteen hands and not exceeding fifteen hands, was well filled. The first-prize animal, Mr. Harry Livesey's *Lily*, "is a beautiful mare, and goes with great force"; she was reserve to the same exhibitor's female champion. The second, Mr. F. W. Buttle's *Rosalind*, "is of the useful sort," and "by her superior force of action" was awarded precedence over Mr. Livesey's *Nellie 3rd*.

Class 25, for hackney mare or gelding, above fourteen hands,

up to 15 stone, foaled in 1885, 1886, or 1887, was chiefly remarkable for the first-prize animal, Mr. William Pope's *Nelly*, "a beautiful hackney with fine manners, and considerably ahead of the others in the class."

Class 26, for mare or gelding, above fourteen hands, up to 12 stone, foaled in 1885, 1886, or 1887, though numerically strong, was somewhat disappointing in merit. Mr. Richard Wright's *Silver King* was first.

Of Class 27, hackney fillies foaled in 1888, exactly the reverse may be said; for though small in numbers it furnished the champion hackney mare in Mr. Harry Livesey's *Lady Keyingham*, whilst the Earl of Londesborough's second and third prize fillies, *Vanity* and *Odd Stockings*, "are good enough to win in almost any company."

The two-year-old hackney fillies (Class 28) made up a fair class, at the head of which was placed Mr. James W. Temple's *Lady Dereham*.

*Ponies* were present in only half the number by which they were represented at Plymouth.

Pony stallions, not exceeding fourteen hands (Class 29), included quite a sensational animal in the first-prize winner, Mr. Charles E. Cooke's *Cassius*. Mr. G. H. R. Francis's *Lord Barsham* proved himself "a good all-round goer." Class 30, for pony brood mare and foal, not exceeding fourteen hands, was of fair quality, Mr. Christopher W. Wilson's *Snorer* being of a thoroughly representative character. Class 31, for pony mare or gelding, above thirteen hands and not exceeding fourteen hands, was of poor quality. Class 32, for mare or gelding not exceeding thirteen hands, was, on the contrary, good, and the first prize went to Mr. William Pope's *Princess*, "an exceptionally fine mover."

*Harness Horses and Ponies*, shown in harness with suitable vehicles, comprised two classes for harness mares or geldings. Class 33, exceeding fourteen hands, was made up of a very poor lot, at the head of which stood Mr. Thomas Bentley's *Performer*. In Class 34, not exceeding fourteen hands, the leading honour fell to Mr. William Pope's thirteen-year-old mare *Magpie*, "who had the pace of the second prize"—Mr. Daplyn's *Norfolk Model*—"which is a very nice mare."

#### HEAVY HORSES.

*Shires*.—These were three times as numerous as at Plymouth last year, and the numbers only fell three short of the remarkable entry at Windsor in 1889. Great merit was displayed through-

out the whole exhibit, but more especially in the young classes of both sexes—a circumstance full of encouragement to the breeders of Shires. Of the 21 prizes awarded amongst the seven classes, six went to Lancashire, four to Warwickshire, two to Essex, two to Huntingdonshire, and one each to the counties of Leicester, Middlesex, Nottingham, Stafford, Worcester, and York, and one to Scotland.

Amongst the three-year-old stallions (Class 35) were some weighty animals, capable of doing good service for the breed. The substantial honours went, in the order indicated, to Mr. P. Albert Muntz's *Forest King* (reserved for the male championship), the Cannock Agricultural Company's *Hartington II.*, and Mr. Alexander Crawford's *Leake Pioneer*. These were selected rather as sires than as what are often designated show-ring animals.

A big class of two-year-old stallions (Class 36) brought forward some grand animals, including the male champion, Mr. John Rowell's *Bury Victor Chief*, which the Judges are of opinion is the best two-year-old that has been seen since the commencement of the Shire Horse Society. Mr. Charles E. Galbraith's *Twilight* was second, and Lord Middleton's *Silver Prince II.* was third. Despite its general excellence, there were a few animals in this class which had better have remained at home.

The yearling stallions (Class 37) were headed by a colt of size and quality, in Mr. Walter Gilbey's *Saxon Conqueror*, "which must make a grand horse." The second-prize winner, Mr. Thomas Shaw's colt, though of smaller size, is of high merit. Mr. Peter Blundell's *Prince Harold*, which was placed next, is of great substance. Many other animals in this class would have taken prizes had they not been in such good company.

The mares and foals (Class 38) made a weak class, albeit they furnished the female champion in Mr. Fred Crisp's *Starlight*, which secured the like honour at the Shire Horse Show held in February last. She was worthily followed by a nice level roan which moved well, Mr. Muntz's *Dunsmore Fashion*. The Duke of Portland's *Scarcliffe Kathleen* was third. "The foals were a mean lot."

The three-year-old fillies (Class 39) found much favour in the eyes of the Judges, who commended the whole class, "and cannot say too much in their praise." Two of the animals were good enough for champions, and Mr. J. P. Cross's *Mavourneen* secured the reserve card for the female championship. Mr. John Conchar's *Flower of May* was second, and Lord Winmarleigh's *Wagtail* was third.

The two-year-old fillies (Class 40) included animals of

great size, but some of the best were slightly overdone. The solid honours went, in order, to Messrs. H. and R. Ainscough's *Aurora*, Mr. James Blyth's *Blythwood Bountiful*, and Lord Hindlip's *Hindlip Lady*.

The yearling fillies (Class 41) were of very good character throughout. "A better animal than the first-prize filly (Mr. T. Horrocks Miller's *Marina*) has been seldom met with at any show." Mr. John Rowell's *Bury Countess* "was of great merit." The third prize went to Mr. Walter B. Longton's *Cronton Ladylike*.

*Clydesdales* made up 57 entries, against 36 at Plymouth last year, and 93 at Windsor in 1889. Of the *Clydesdales* in the Doncaster catalogue, 30 were entered from Scotland, 23 from England, and four from Wales. Of the 20 prizes awarded in the seven classes, 14 went to Scotland, four to England and two to Wales. The two champion prizes and the reserves were secured by Scotch exhibitors.

In a small but good class of three-year-old stallions (Class 42) the first prize went to Mr. William Montgomery's *Breastplate*, and the second prize to Mr. William Graham's *Maccash*,—"both first-class animals, having good feet and legs, free action, and possessing all the characteristics of the breed."

The largest class of *Clydesdales* was that for two-year-old stallions (Class 43), which contained 13 entries, some of them possessing remarkable excellence. Mr. William Renwick's *Prince Alexander* is a splendid type of the breed, and was selected to wear the male champion colours. The reserve champion card went to Mr. Andrew Montgomery's *Prince Patrick*, an admirable mover, and possessed of first-rate feet and bone. Mr. A. Montgomery's *Macquhae* took the third prize.

The yearling stallions (Class 44) quite maintained the quality of the older classes. Mr. A. Montgomery's *Ross Macgregor* was placed first.

Class 45, for mare and foal, attracted some useful entries. The prize-winners—Mr. William Graham's *Lizzie of Inchparks*, the Earl of Cawdor's *Bell*, and Lord Polwarth's *Comfort*—"were a first-class lot, and quite the stamp to propagate the best class of *Clydesdale* horses."

The three-year-old fillies (Class 46) furnished the female champion in Mr. Sinclair Scott's *Scottish Snowdrop*. The Earl of Cawdor's *Decreto* was second, and Mr. Patrick Stirling's *Brenda of Kippendavie* was third. "The second, third, and fourth were also splendid specimens of the breed, any one of which might have made a good first in any showyard, possessing as they did plenty of size, and the best of bone, feet, and action."

Of two-year-old fillies (Class 47) six came forward. Mr. William Montgomery's first-prize filly *Crosby Rose* "was a very superior animal, and was reserved for the cup."

In an excellent class of yearling fillies (Class 48) the first prize went to the Earl of Galloway's *Lillie Langtry*, and the second prize to Mr. Andrew Mitchell's *Muriel*. These were of exceptionally good quality, and the Judges considered that there was very little difference between them.

*Suffolk.*—Though much nearer the home of the breed, Doncaster failed to attract as many entries of Suffolk horses as Plymouth, the respective numbers being 56 and 41. With four exceptions, all the 41 entries were made from the county of Suffolk, which carried off 13 out of the 14 prizes awarded in the five classes.

The three-year-old stallions (Class 49) were fairly representative of the Suffolk breed. "As a whole they were rather beyond the average size, and perhaps if the same bulk had in most cases been closer to the ground the great characteristic of the breed would have been a more pronounced feature." Mr. James Toller's *Rainbow* "is a wholesome kind of farmer's cart-horse, with no remarkable defect, uniformly built, and of great size and power—enough so to recommend him to those who aim at breeding London horses." Mr. Horace Wolton's *Trumpeter* "is perhaps rather more of the Suffolk stamp, but his somewhat cross front and low heels are against him." Mr. William Everitt's *Warrior* "is a very smart but undersized model of a Suffolk horse."

Of the stallions foaled in 1889 (Class 50) Messrs. I. Pratt and Son's *Eclipse*, "though not particularly handsome, and with less of the Punch type than in the two horses placed next to him, affords little to find fault with,—his feet and legs are good, and he moves very well." The Duke of Hamilton's *Wedgewood 2nd* "is a somewhat overtopped colt, but of vast width and muscular development."

In Class 51, for mare and foal, whilst the Duke of Hamilton's *Queen of Diamonds* went at once to the front, the claim to second place was warmly contested by Mr. W. Henry Hewitt's *Juno* and Mr. Horace Wolton's *Pearl*.

The three-year-old fillies (Class 52) did not give the Judges much trouble. The first prize went to the Duke of Hamilton's *Morella*, "a grand, all-round good mare, big, handsome, and truly made." Mr. James Toller's *Violet*, "a filly with almost enough silver hairs to be called a roan," was a fair second.

The two-year-old fillies (Class 53) furnished another winner from the Duke of Hamilton's stables in *Queen of Trumps*, "a

short-legged thick-built mare, with lumpy, upright, short shoulders, which gave her fore-end a common look." Messrs. Wilson's *Darling*, "too long and loose-made for a model Suffolk," was second. But for her fore-legs, Mr. Hume-Webster's *The Miller's Daughter* might well have gone to the front.

*Agricultural Horses.*—These were rather more numerous than at Plymouth, and were generally of great weight and size. In Class 54, for geldings of any breed, foaled in 1887 or 1888, there were seven entries from Yorkshire and four from other counties. Lord Wantage took the first prize. The three entries in Class 55, which were all present, came exclusively from Yorkshire, Mr. Henry Lawson's *Briton* being placed first.

The report upon the results of the veterinary examination of Stallions will be found in the Appendix, page lxxxix.

#### CATTLE.

*Shorthorns* were in the catalogue to the number of 116, which is about double the entry at Plymouth last year. Scotland sent 12 entries, but only from two exhibitors; Wales accounted for four entries, and Ireland for one. The English entries came from as many as 21 counties; Yorkshire being responsible for 21 entries, Nottinghamshire for 17, Cumberland for nine, and Lincoln, Norfolk, and Northumberland for half-a-dozen each. Of the 21 prizes awarded in the seven classes, six went to Scotland (Berwickshire), besides the two champion plates; 14 went to England (Wilts three, York three, Berks two, Cumberland two, Notts one, Northumberland one, Rutland one, Worcester one) and one to Wales (Carmarthenshire).

Shorthorn bulls, born in 1885, 1886, 1887, or 1888 (Class 56), made up a fairly numerous section of moderate quality, at the top of which was placed Mr. Evan Jones's three-year-old roan *Nugget*.

In a good lot of two-year-old bulls (Class 57) the male champion was found in Lord Polwarth's *Windsor Royal*. Amongst the yearling bulls (Class 58) were several very promising young animals, with, however, "a tail" of moderate ones. Here, Mr. Willingham Fowler's *Eryholme Prince 35th* received the reserve card for the champion plate.

Cows born before 1888 (Class 59), though but a small entry, were all good. Lord Polwarth's *Wave of Indiana* was first, and his *Wave of Loch Leven* was second.

The three-year-old heifers (Class 60) made up a very good



class. The first-prize heifer, Lord Polwarth's *Truth*, was decorated with the female champion colours. Mr. William Graham's *Windsor's Beauty* was second, and the Duke of Northumberland's *Fairy Rosebud* was third.

The best of the Shorthorn Classes was that for two-year-old heifers (Class 61), and the Judges commended the lot. Lord Polwarth's *Gladsome Wave* was placed in reserve to the same exhibitor's older heifer for the championship. Her Majesty the Queen was awarded the second prize for *Rosalind*, and Mr. Deane-Willis was third with *Lady Madge*.

Yearling heifers (Class 62) made up a large class of moderate quality, at the head of which was placed Messrs. Harrison's *Fern 8th*, followed by the Queen's *Rosemary* and Mr. Deane-Willis's *Vinolia*.

*Herefords*, which were shown in six classes, appeared in rather fewer numbers than at Plymouth. They led off with a very grand class of aged bulls (Class 63), Mr. W. H. Cooke's *Grove Wilton 4th* possessing special excellence. The Earl of Coventry's *White Boy* "is of great scale, but not so level as the first-prize winner." Mr. J. Hungerford Arkwright's *Spring Jack* "is smaller but of good type."

Amongst the two-year-old bulls (Class 64), the first and second prize animals—Mr. Arkwright's *Rose Cross 2nd* and Mr. A. E. Hughes's *Ironclad*—are "remarkably good specimens of the breed"; whilst Mr. Stephen Robinson's third-prize bull *Sterling* "is not so perfect in form, but likely to make a good stock bull." The yearling bulls (Class 65) were a less satisfactory display than might be expected at a "Royal" Show.

Class 66, for cows born in or before 1888, contained three splendid animals,—the Earl of Coventry's *Ladywood*, and Mr. Thomas Feun's *Bravura* and *Downton Fancy*. "The third-prize cow would have been placed first if she had not had a black nose. The first-prize cow showed better character and was more like a breeding animal than the second-prize cow."

The two-year-old heifers (Class 67) were a fine class, the first and second heifers—Mr. Richard Green's *Diana* and Mr. E. S. Godsell's *Sunbeam*—being very superior animals. Yearling heifers (Class 68) were a large class of good quality. Mr. Green's first-prize heifer *Perilla* "possesses great scale, with quality and character."

*Devons* were a long way from home at Doncaster, and they were catalogued only to the number of 20 as against 52 at Plymouth last year. With one exception the ten prizes awarded in the four classes all went to West Country herds, and Sir

William Williams took all the first prizes. The exhibits throughout manifested careful and judicious breeding. The first and second prize animals in Classes 69 and 70, for bulls, and the first prize animal in Class 72, for young heifers, displayed in a marked degree the correct type and true character of the Devon breed.

*Sussex* cattle appeared in the same number at Doncaster as at Plymouth. There was no competition in the aged-bull class, but the Judges had no difficulty in awarding the first prize (Class 73) to its solitary occupant, Mr. C. T. Lucas's *Golden Horn*. In Class 74, the prizes went to Mr. Joseph Godman's *Oxford Duke 4th*, Mr. Stewart Hodgson's *Rochester*, and Mr. W. Stewart Forster's *Gondolier*—all very useful animals. "The younger bulls did not show to the best advantage, as they were heavily handicapped by being classed with animals so much older." In Class 75, the prize-winning cows were those of Mr. Hodgson, Mr. Forster, and Mr. Louis Huth. All the heifers in Class 76 were commended, the winners—Major Best's *Pearl*, Mr. George White's *Ninon*, and Mr. Hodgson's *Crocus 3rd*—being exceedingly good. The disparity of ages made the Judges' task a difficult one.

*Welsh*.—Of this hardy breed there were four exhibitors and ten entries, all of the latter being present. Small as is this number, it is more than double the entry of Welsh cattle at Plymouth. Those at Doncaster all came from the Principality, and were all good specimens of the breed. Lord Harlech's first-prize bull (Class 77) "is of great scale and shows strong constitution." Col. Henry Platt's first-prize heifer (Class 78) "would do credit to any breed." The same breeder's Windsor champion, *Tudno*, was placed second.

*Red Polled* cattle, though very much nearer to East Anglia, only came forward in the same number as at Plymouth. Hence the Judges say, "We were much disappointed to find the competition for this useful breed of cattle of so limited a character, nor do we think the standard of merit at all equal to that of many previous exhibitions." The 29 entries were arranged in four classes. Of aged bulls (Class 79) only four were shown, and the first and second prize animals were of good type, the former, Mr. J. J. Colman's *Bardolph*, obtaining the champion prize as the best Red Polled animal, and the latter, Mr. Tyssen Amherst's *Masher*, getting the reserve. Amongst the young bulls (Class 80) Mr. Colman's *The Gem* was first; and though there were but four entries the competition was so strong that the Judges recommended the award of a third prize.

Of the cows (Class 81) Mr. Harry P. Green's *Gleam 3rd* was first, but "some difficulty was experienced in making

the awards, in consequence of animals of only a little over two years old having to compete with elderly matrons." In Class 82, several of the heifers scarcely presented the appearance of breeding animals. Some of the younger ones were of good type, but were rather small for their age. Mrs. Elizabeth Perkins took the first prize with *Ivy 3rd*.

*Aberdeen-Angus*, not represented at Plymouth last year, made up 27 entries, in four classes, at Doncaster. Of these, 17 were entered from English herds, and 10 from herds in Scotland. As showing the extensive area covered by the "Doddies," it is worth noting that, of the entries from England, Northumberland sent five, Notts three, Yorks three, Bucks two, Durham two, Lincoln one, and Sussex one. The Scotch entries were—Aberdeen four, Inverness two, Perth two, Fife one, Ross one. Of the twelve prizes awarded, Scotland took four, and England eight. English exhibitors took all three prizes for the young heifers (Class 86).

The display was of a distinctly meritorious character. The aged bulls (Class 83) reached a very high standard, and Mr. Arthur Egginton's *Epsom* was placed first. Class 84, for young bulls, was well filled, and the place of honour was occupied by Mr. James T. Cathcart's *Julius Caesar*. The cows (Class 85) were of a quality which is rarely to be seen excelled in public competition; whilst the heifer class was most creditably filled. In the former, the Marquis of Huntly's *St. Agnes* was first; in the latter (Class 86), Mr. Egginton's *Valentine 5th*.

*Galloways* made a fine show. Of the 24 entries, six were from the English side of the border. The aged bulls (Class 87) comprised a couple of excellent specimens from the Duke of Buccleuch's herd. For young bulls (Class 89) the leading honours went to Mr. James Cunningham. The cows (Class 89) were a meritorious lot, more especially the prize-winners—Mr. Cunningham's *Maggie of Tarbreoch*, the Countess of Carlisle's *Vaudeville of Closeburn*, and the Duke of Buccleuch's *Pride 4th of Drumlanrig*. In a good class of heifers the first prize went to Sir Robert Jardine's *Lady Tidy 3rd of Castlemilk*, "a first class animal, possessed of great substance and quality although only one year old."

*Ayrshires*.—The Scotch milking breed made a very small show of half-a-dozen entries, equally divided into two classes. Of three good bulls (Class 91) the first prize animal was Mr. Mark J. Stewart's *Hover of Southwick*—"as good an animal as we have seen this season in Scotland." The cows (Class 92) were all worthy of their prizes, Mr. Andrew Mitchell's first prize cow, *Eleanor*, being of good quality and very stylish.

*Jerseys*.—There were 192 entries of this favourite breed, the number being somewhat in excess of that in the Plymouth catalogue. The quality of the individual animals was, as a rule, very high. The 18 prizes awarded in the six classes were well scattered, Herts taking four, Essex three, Somerset three, Pembroke two, Yorks two, Bucks one, Cambridge one, Derby one, and Dorset one. Of the 18 decorated cattle, 11 were bred in Jersey, and 7 in England and Wales.

Amongst the aged bulls (Class 93), the Judges found that the wide differences between the ages placed the older animals at a great disadvantage, as the younger ones are almost invariably more symmetrical. The first prize went to a bull of great richness in Mr. J. W. Crookes's *Pomona's Daily*. Though of similar type, Sir Reginald Graham's *Norton Nero* was "not so rich and not so good in setting on of tail." Mr. W. E. Budgett's third-prize bull, *Roseberry*, possessed great length and quality. These three bulls were none of them island-bred.

Of the yearling bulls (Class 94) the first-prize animal, Mrs. McIntosh's *Penny Come Quick* "has grand lines, a heifer-like head, and great length, but is a trifle throaty." Lord Rothschild's *Gift*, "not quite so good in line of rump and setting of tail," was second; and Mr. Percival H. Fowler's *Bird*, "of great merit but rather light in quarter," was third. These winners were all island-bred.

In Class 95, for cows in milk, born in or before 1887, the first prize went to Mr. James Blyth's *Lady Safety*, "a small cow of true Jersey type, with splendidly shaped udder and fine milking points." The Earl of Londesborough's *Précoce II.* is "an excellent dairy cow, but shows a tendency to lightness in the near-side quarter of the fore-bag." Mr. William Arkwright was third with *Carillon*, "a grey cow, rather undersized, but of great milking capability; not quite clean in throat." There was scarcely an animal in this class which did not possess considerable merit. The three winners were island-bred.

Class 96, for three-year-old cows, was the smallest of the Jersey classes, the entries numbering twenty-five. The substantial awards all went to island-bred cows. The first-prize cow, Mr. Walter Barron's *Lady of the Lake 4th*, carried a remarkable udder, which was, however, slightly wanting in colour. She was almost equalled by Mr. Blyth's *Princess Alice*, but the latter is "a little long on the leg." Mr. Joseph Brutton's *Mabel 21st* is a yellow fawn of good quality.

In the two-year-old heifers (Class 97), the winner was Mr. H. J. Cornish's *Miranda*, "a bronze fawn of great beauty,

with good head and horn, and good udder." Mr. Brutton's *Golden Lass 7th* proved a little coarse in the hind quarters. Mr. Baxendale's *Berberis* is a home-bred heifer of great milking quality, "but a little ungainly in horn."

The yearling heifers (Class 98) made the largest of the Jersey classes, with 40 entries. The first prize went to Lord Rothschild's *Pontorson 2nd*, "a grey calf with perfect outline, good promise of udder, and well-placed teats. Mr. Edwin Cash's *Mamie* has great depth and quality, but is not perfect in touch. Mr. J. W. Crookes took third prize with *Bessie Black*. These three heifers are all home-bred.

*Guernsey.*—In the four classes there was a total of 51 entries, of which 46 went into the ring. The former number compares with 72 in the Plymouth catalogue; but the distance of Doncaster no doubt had its effect, and only five animals were entered direct from the island. The quality of the display was, on the whole, equal to the average of recent years. Of the 12 prizes awarded, seven went to animals bred in Guernsey.

Several of the aged bulls (Class 99) possessed great merit, and the first prize was awarded to Mr. Christie-Miller for *Our Prince*. This bull was island-bred, as were also the second and third, Mr. H. M. Ozanne's *Ringleader* and Colonel Shakerley's *Paradox*.

Only five yearling bulls (Class 100) came before the Judges. "This, in point of merit, was the weakest class in the section, the animals being more or less inclined to throatiness." The winners were none of them island-bred.

Class 101, for cows calved in or before 1888, was of great merit. Before finally making their awards the Judges had the selected animals milked in order to assure themselves that the udders when empty were still satisfactory. Sir Francis Montefiore's island-bred *Fortuna* was first, Mr. Julian Stephens's island-bred *Muriel* was second, and the Hon. Mrs. A. Baillie Hamilton's home-bred *Romaine 3rd* was third.

The two-year-old heifers and yearling heifers competed together in Class 102, and the contest resulted in the victory of three island-bred animals, Sir F. Montefiore's *Volunteer* being first. This was the largest of the Guernsey classes, 21 animals coming forward. "The Judges found great difficulty in making their awards in consequence of having to compare yearling with two-year-old heifers." As a matter of fact each of the winners was nearly  $2\frac{1}{2}$  years old. "The younger animals have very little chance in competing with those a year older, many of which have calved, or are near calving, and showing signs of udder development." Although the class was open to heifers "born in the

year 1889 or 1890," the catalogue shows that more than two-thirds of the entries were born in 1889.

*Kerry and Dexter Kerry.*—The aggregate entry of these breeds was less than half as large as that at Plymouth in the preceding year. Irish exhibitors were, on account of recent regulations, absent; but the English exhibitors represented as many as nine different counties: Bucks, Cambs, Hants, Kent, Norfolk, Notts, Oxon, Rutland, and Wilts.

Kerry bulls (Class 103) were "a poor class of six animals," in which Mr. Martin J. Sutton's *Kidmore Prince* was first, and Mr. Charles Adeane's *Blackamoor* was second. "Undoubtedly the best animal *per se* was No. 1309 (the Duchess of Newcastle's *Forest Shamrock*); but if the rules of the Irish Kerry Herd Book Society are to be regarded, especially in male animals—a point open to question,—he was disqualified on such rules. The two animals, first and second, were the only two of which mention could be made."

Kerry cows or heifers (Class 104) entered the ring to the number of 11. It was a nice class on the whole, though several animals were deficient in formation of the udder. The first prize fell to Mr. Martin J. Sutton's *Peep*, and the second prize to the Marquis of Lansdowne's *Enda*. "The first-prize cow, although having more white than permitted by the Irish Kerry Herd Book Society, could not be passed, as she is in every other respect a very perfect specimen of a Kerry and a dairy cow. The second-prize animal was a good typical Kerry, and the other noticed cows were all thoroughly good specimens."

Amongst the Dexter bulls (Class 105) Lord Ashburton's *Chung* "was easily first." The second-prize bull, Mr. Sutton's *Othello*, and Mr. Swithinbank's reserve, "were very equal in merit, there being very little to choose between them." The second-prize animal, however, "had the advantage in touch."

Class 106, for Dexter cows or heifers, was a very strong class, in which the solid awards went to Lord Ashburton's *Queen Mab* and Mr. Swithinbank's *Denham Lady Limerick*. When seven out of the 16 had been drafted, the placing of the others was a matter of considerable difficulty, and eventually the Judges were obliged to ask the umpire to decide between the first two animals—a task in which Mr. Robertson confessed there was very little margin of choice.

"It is very clear," say the Judges, "that if the presence of *white* in Kerrys is to disqualify, as at present insisted upon by the Irish Kerry Herd Book Society, injustice will be done to good individual animals, and great injury to the breed in general."

## DAIRY CATTLE MILKING TRIALS.

Six prizes, amounting in the aggregate to 60*l.*, were offered for cows in-milk, of any breed or cross, the awards going to the animals which yielded the largest quantity of milk at two milkings, provided the quality of the milk did not fall below a standard of 12 per cent. of solids and 3 per cent. of butter-fat. The cows were divided into two classes (107 A and 107 B), according as their live-weights, taken after being milked dry, came above or below 1,100 lb.

The cows were milked dry on Monday morning, June 22, in presence of the Steward of Cattle, Mr. C. S. Mainwaring, after which their live weights were taken on a platform weighing machine, conveniently erected by Messrs. Avery, of Birmingham, at the end of the dairy cattle shed. The weights then registered were those for the purposes of the competition, and it was found that of the twelve entries there was one absentee (No. 1372), and that Division A comprised six, and Division B five animals.

The two milkings by which the competition was decided were made on Monday evening, June 22, at 5 P.M., and on Tuesday morning, June 23, at 7 A.M. The milk yielded was weighed, and samples were on each occasion taken for analysis, and sent for examination to the Society's laboratory.

The table on page 465 gives particulars as to the cows, their live weights, the quantity and quality of the milk yielded, and the consequent awards.

As distinguished from the competitions of former years it is noticeable, reports Dr. Voelcker, that in only one case (No. 1374) did the quality of the milk given fall below the standard, and even then only just below it. In more than one case it was ascertained that the competitors had taken the precaution to have the milk of their cows analysed before they were sent to the Show, in order to know that the conditions would be satisfied. It will be noticed, however, that in one or two instances the quality of the Tuesday morning's milk was below the standard, though that of the Monday evening was well above it. As the conditions did not specify that at each separate milking the standard must be reached, the average quality of the yield of the two milkings was taken as the determining factor, and, as may be seen, in all cases except one (No. 1374) it was reached.

In Division A the first prize was awarded to *Dairyman's Pride*, a roan cross-bred cow, five years old, belonging to a local exhibitor, Mr. James Brammer. She had never been exhibited

at any show before this; but the owner, knowing the large yield of milk the cow gave, sent her for competition, as the Show was in the neighbourhood. This cow gave the extraordinarily large yield of  $72\frac{1}{2}$  lb. of milk at two milkings, a quantity considerably in excess of anything recorded either at Plymouth last year or at Windsor in 1889, the greatest yield from any cow at the latter Show being  $64\frac{1}{2}$  lb. Naturally the quality was not high, but on the average of the two milkings it came above the standard, showing 12·01 per cent. of solids and 3·07 per cent. of fat. This cow had calved on April 25, and the owner stated that she only went dry for about four weeks. Bean and pea-meal, oats, and maize-meal, with a little linseed-cake, were the usual additional foods. Mr. George Church secured the second and third prizes in this division with two shorthorns, one of them, No. 1368 (*Miss Cope*), being well known at milking competitions, and having shortly before won at the Oxfordshire Show. However, she was here placed below her companion, No. 1369 (*Nancy*), the latter having calved as recently as June 2, while *Miss Cope* had calved on April 6. Bean-meal and crushed oats, with, in winter, cotton- and linseed-cake, are the additional foods Mr. Church uses. The Shorthorn cow No. 1370 (*Strawberry*) only lost the third prize by a few ounces less yield of milk.

It is worthy of note in this competition that, although there were cows entered which weighed 1,300 lb. and 1,400 lb. live weight, by far the greatest yield was given by the lightest cow of all, her weight being only 1,127 lb., so that she narrowly escaped being placed in the other division.

In Division B, although the yields do not equal the Windsor returns in 1889, the quality of both morning and evening milkings was extremely good, and in no case was the standard not reached. Here, again, the first prize was won by the lightest cow, and the second prize by the next lightest, the heaviest cow of all only obtaining the third place. The first and second prizes went to Jersey cows, the third to No. 1369A, a big cow of unknown breeding, belonging to Mr. George Church, who thus secured three of the six prizes offered. This cow, *Flower*, had taken a silver medal at last year's Dairy Show. The first prize cow, No. 1373 (*Daystar 2nd*), belonging to Mrs. Swan, was a beautiful animal, and showed remarkable development of the milk veins. She was no less than eleven years old, and had calved on April 1. Mr. Salisbury Baxendale's four-year-old Jersey cow, *Blossom*, was second.



CLASS 107.—COWS IN MILK, OF ANY BREED OR CROSS, GIVING THE GREATEST QUANTITY OF MILK CONTAINING NOT LESS THAN 12 PER CENT. SOLIDS AND 3 PER CENT. BUTTER-FAT.

No. in Catalogue	Name of Exhibitor	Breed of Cow	Live-weight	Yield of Milk in lb.			Total Yield	Results of Analysis						Award		
				Monday evening		Tuesday morning		Monday evening's milk		Tuesday morning's milk		Solids	Fat		Solids	Fat
				lb.	oz.	lb.		oz.	per cent.	per cent.	per cent.					
<b>DIVISION A</b>																
<i>(Cows over 1,100 lb. live-weight)</i>																
1366	James Brammer . . .	Crossbred	1127	33 8	39 0	72 8	3.52	12.38	2.69	11.71	1st Prize					
1368	George Church . . .	Shorthorn	1281	26 4	32 4	58 8	3.78	12.77	3.29	12.12	3rd Prize					
1369	George Church . . .	Shorthorn	1407	29 12	35 0	64 12	3.81	12.88	3.14	11.77	2nd Prize					
1370	John Evens . . .	Shorthorn	1225	26 0	32 4	58 4	3.67	13.23	3.17	12.86	—					
1371	Sir F. Montefiore, Bart. . .	Guernsey	1134	17 14	20 2	38 0	3.99	13.30	3.35	12.85	—					
1374	T. & F. Train . . .	—	1358	20 4	35 0	55 4	2.53	11.53	3.41	12.45	{ Below Standard					
<b>DIVISION B</b>																
<i>(Cows under 1,100 lb. live-weight)</i>																
1364	S. Baxendale . . .	Jersey	854	16 8	20 12	37 4	5.05	14.31	4.94	14.12	2nd Prize					
1365	Mrs. Blackwell . . .	Jersey	889	12 0	15 4	27 4	5.95	15.88	5.32	15.19	—					
1367	J. Brutton . . .	Jersey	777	10 14	12 12	23 10	5.72	15.02	4.59	14.16	—					
1369A	George Church . . .	—	1078	16 8	19 6	35 11	5.34	13.25	4.22	12.38	3rd Prize					
1373	Mrs. Swan . . .	Jersey	847	21 11	24 14	46 12	5.17	14.65	4.31	13.81	1st Prize					
1372	Absent . . .	—	—	—	—	—	—	—	—	—	—					

J. AUGUSTUS VOELCKER, Consulting Chemist.

June 24, 1891.

## SHEEP.

*Leicesters.*—It was hardly creditable to the breeders of Leicester sheep that they should make a smaller entry at Doncaster than at Plymouth. Excepting the first and second prize pens in the ram classes, Leicesters do not call for any special comment, though the Judges were pleased with the shearling ewes.

*Cotswolds.*—Two dozen pens were entered, which again falls short of the Plymouth entry. The quality was good. The two-shear rams, for which Mr. Russell Swanwick was first and second, gave much satisfaction; and the Judges noticed all the pens that were occupied. The shearling rams, in which class Mr. Robert Garne was first, were equally satisfactory. Of ram lambs, Mr. Garne's prize pens were "very good, but backward in condition." Messrs. Bagnall's prize pens of ewes were typical specimens of the breed.

*Lincolns.*—The Lincoln breeders took advantage of their proximity to the place of meeting, and entered to nearly twice the extent of their display at Plymouth. The substantial honours throughout went either to Mr. Henry Dudding or to Mr. Robert Wright. The shearling rams were a specially strong class, both in numbers and in quality.

*Oxford Downs* were shown in about the same strength as at Plymouth. The two-shear rams made up a small but excellent class, Mr. John C. Eady's first-prize ram possessing exceptional merit. Mr. John Treadwell carried away all the money offered for shearling rams,—a good class in which 14 animals faced the Judges. The ram lambs, in which Mr. Albert Brassey's pen was placed first, were so good that they were all noticed. In a capital lot of shearling ewes, Mr. Eady's first-prize pen was especially noteworthy.

*Shropshires.*—The cultivators of the West Midland breed of sheep may look back with satisfaction upon their imposing display at Doncaster. Two sets of Judges took the Shropshires in hand, the one set dealing with the rams, and the other with the ram lambs and ewes. The Judges of rams "congratulate the breeders of Shropshires on the wonderful entry of 127 rams in two classes, nearly all of which put in an appearance, some from the most distant parts of the United Kingdom, both Scotland and Ireland being most creditably represented. There were 41 different exhibitors, plainly showing the still increasing popularity of this breed. A considerable number of sheep in each class were sold in the yard at high figures for exportation to America and the Colonies; at the same time we were pleased

to hear that some of the most valuable sires were retained at very remunerative prices to perpetuate the breed in this country."

Of two-shear rams there were 26 entries present. Mr. George Lewis's first-prize ram is a typical animal of the breed, with capital fore-quarters and good masculine head. Mr. A. S. Berry's second-prize ram, "though hardly so pleasing in character, is a wonderfully straight good sheep with capital coat and skin." The third-prize sheep, exhibited by Mrs. Barrs, is "of grand scale, with good lean flesh."

The shearling rams made up an extraordinary entry of nearly 100 animals, many of them possessing exceptional quality. Mr. W. F. Inge's first-prize ram was a sheep of capital form and character, standing square on his legs, "though we could have wished him to have moved with greater freedom." Messrs. Bradburne's second-prize ram, despite his being of nice character and well on his legs, was "hardly so pleasing in form or firm in his coat." The third prize went to a sheep of very much the same type, and the strength of the whole class is shown in the circumstance that as many as 23 animals were selected for nominal honours.

Of ram lambs 17 pens were filled, and they made a highly creditable show. Mr. Richard Brown's first-prize pen "was of very good quality and size, and free from any defects in the way of stubs or grey ears, &c." The second-prize and reserved pens were compact lambs of beautiful quality.

The class for shearling ewes produced some splendid specimens of the Shropshire breed, and on account of their uniformity of character some difficulty was experienced in adjudicating. After a close contest the first prize was awarded to Mrs. Barrs for a pen of great size and evenness. Mr. Inge's second-prize pen "was not on quite so large a scale, but of beautiful quality."

*Southdowns.*—There were 81 pens entered at Doncaster, against 75 at Plymouth. East Anglian breeders took all the four first prizes and an equal number of others, only three of the eleven prizes awarded going to Sussex flocks.

The dozen entries of two-shear rams did not make up a strong class, though the prize animals were good. The first prize went to the Prince of Wales for "a remarkably true-made sheep of excellent quality." Mr. Colman's second-prize ram was "nearly of equal merit," and the Duke of Richmond and Gordon's third-prize sheep "true to Southdown type." One of the Judges (Mr. Fulcher) suggests the abolition of classes for two-shear sheep, and says "there can be little doubt that to

feed a ram for show after he has attained maturity seriously impairs, and often totally destroys, his usefulness as a breeding animal."

Shearling rams made a creditable display. In placing the first two animals, it was necessary to seek the opinion of an umpire, the result being that the first prize went to Mr. Colman and the second to the Prince of Wales.

In the class for ram lambs the first prize pen—also from Sandringham—obtained its position on account of the lambs being so well matched, this, combined with their quality, more than compensating for some lack of size. Mr. Lucas's second-prize pen looked younger, but were a highly promising lot. "We were sorry to find several lambs disfigured by embryo horns."

The Southdowns were seen at their best in the female class. "Seldom has such a splendid array of ewes been seen at the Royal, and in appreciation of their merits we highly commended the whole class." The Duke of Hamilton and Brandon's first-prize winners, says Mr. Gorringe, "were marvellously symmetrical and their quality was excellent;" whilst Mr. Fulcher reports: "These ewes remind me of old Babraham days, when Southdowns had more colour, size, and strength of constitution than those of the present day." The second prize went to Mr. Colman and the third prize to Mr. Toop for "pens of the highest merit."

*Hampshire Downs.*—Of these, 50 entries were made—about a dozen more than at Plymouth. Most of the leading breeders were represented, and the early maturing qualities of the breed were much in evidence. For two-shear rams the first prize went to Mr. Robert Coles for a very good sheep, Mr. Frank R. Moore's second-prize ram being a "trifle high on the leg." Amongst the shearling rams Mr. John Barton took the first prize for a massive sheep of good constitution. "Perhaps the best sheep in the class took no honours, as he was so fat he was unable to stand to be judged; he belonged to Mr. Henry Lambert."

Ram lambs mustered in good force, and were very near together in several cases. Mr. Lambert came to the front with a pen of lambs of high quality; whilst another pen of strong useful lambs secured the second place for Mr. Barton. The shearling ewes were an excellent lot, and besides the first and third prize pens of Mr. William Newton and the second-prize pen of Mr. Joshua East, several other pens were noticed.

*Suffolks.*—These black-faced sheep were shown in the same number as at Plymouth. The Marquis of Bristol was first for two-shear rams and for ram lambs, Mr. Edward Gittus being first for shearling rams. The "gems of the Suffolks" on this

occasion were, however, the shearling ewes, for which the first prize went to Mr. Joseph Smith for a pen of the genuine Suffolk type, and the second to Messrs. Roberson and Gough for some remarkably neat and well-grown ewes.

*Wensleydales.*—At a Yorkshire Meeting it was appropriate that a section should be set apart for Wensleydale sheep, of which 41 pens were entered from nine different breeders. They all hailed from that north-western district of the county of which Thirsk, Bedale, and Kirkby Lonsdale are the centres. The display, taken as a whole, was fairly satisfactory, and furnished an opportunity of seeing some typical specimens of the breed. In a fair class of two-shear rams, Mr. J. O. Trotter's first-prize sheep and Mr. John Heugh's second-prize sheep were both good animals. Mr. Heugh was the most successful exhibitor in a large class of shearling rams. The ram lambs, though good in quality, were, owing to the late spring, very backward in condition. The shearling ewes were an exceedingly good class,—the Judges “have never seen a better.” Mr. Heugh was again first, both for lambs and for ewes.

*Border Leicesters* naturally found a place at a North Country meeting. There were 30 entries, of which 10 were from Scotland. The exhibitors numbered seven, Yorkshire providing four, Cumberland one, and Scotland two. The Judges regarded the display as “an improvement on previous years, both in numbers and quality.” There were three classes, and in each case the first prize went to the Right Hon. A. J. Balfour, M.P. “The class of old rams was a fair turn-out. The competition was closer in the shearling rams, some very nice animals being shown. The show of shearling ewes was very good indeed comprising some very fine specimens of Border Leicesters.” On account of the number and excellence of the exhibits the Judges suggested a third prize in each class.

*Cheviots.*—The three classes attracted 16 entries, sent exclusively by two Northumberland exhibitors. The honours were divided as equally as possible between Mr. Jacob Robson and Mr. John Robson. The old rams were a good class, the shearling rams being not so meritorious. “Part of the rams were in the wool, unshorn, and part shorn. The Judges cannot approve of this mixture, and would suggest that it would be better if all were shorn.” There was a close competition amongst the shearling ewes, and the class was very deserving of commendation.

*Black-Faced Mountain.*—Twenty-six entries were made on behalf of six English and three Scotch exhibitors. The old rams were of high merit, an entry by Mr. J. Archibald being first. “The

animal carrying first honours," say the Judges, "combines in a high degree the distinctive qualities of this hardy breed, and seldom, if ever, has a better appeared before us in a showyard, north or south." Mr. Sinclair Scott's ram was placed at the head of a fair lot of shearlings, and Mr. Donald T. Martin's pen was first in a very meritorious class of shearling ewes. The Judges suggest that in future this breed of sheep should be shown either in the wool, or clipped.

*Lonks.*—Of this local breed, seven entries were made, representing three flocks. Messrs. Walton Brothers took all three first prizes. The first-prize ram was good in every way, and the second one was well deserving of a prize. The two shearling rams were also good, and the ewes were a first-rate class.

*Herdwicks.*—Twenty-two entries from five flocks made up this display. Mr. William Abbott's first-prize ram showed not only fine symmetry, but was destitute of black wool, which often occurs in this breed, and which the Judges think very objectionable. The shearling rams were the best class; almost every one deserved a prize, and there was great difficulty in placing them. Mr. James C. Bowstead took the first prize, and Mr. Henry C. Howard the second. In a good class of ewes Mr. Abbott's first-prize pen excelled both in symmetry and in wool. The Judges suggest that in future a third prize be given in all classes. "The Herdwicks come a long distance, and can live upon poor rocky mountain land, where no other class can live."

#### PIGS.

*Large White Breed.*—There were only 33 entries, against 52 at Plymouth. Boars born in 1890 were "a very poor class, with the exception of the first prize"—Mr. Sanders Spencer's Boar pigs, for which Mr. Joseph Nuttall was first, displayed "great want of merit." Breeding sows, on the other hand, made "a good class, one of the best in the Show"; the Hon. Mrs. Meynell Ingram took the first and second prizes. In "a fair class" of sow pigs one of Mr. Spencer's pens was first.

*Middle White Breed.*—There were 26 entries, which was about the same as last year. There were only two boars, "neither good." Boar pigs were "very poor." As to breeding sows, "the winning pigs were good, but the class on the whole was disappointing compared with former shows." Of sow pigs the first-prize pen was good, "but showing too much large character;" the rest were inferior.

*Small White Breed.*—These were rather more numerous than at Plymouth. For boars the Hon. D. P. Bouverie took

the first prize for an animal "true to type, but rather plain in his head." Boar pigs produced but a weak competition. The breeding sows were fairly good, the first and second prize animals—Mrs. Meynell Ingram's—being "of very even merit." The class of sow pigs was "very poor."

"The general exhibition of white pigs," say the Judges, "is of a very disappointing character, both as regards number and quality, and greatly inferior to former Shows of the Society."

*Berkshires*, although entered to the extent of nine more pens than last year, were "not so good as usual." Boars were a very moderate class. The winner was a fairly good pig; the second "a useful pig with a sow's head." Boar pigs made a moderate class; "the winners were a nice even pen, but not particularly well marked." Breeding sows were a very good class; Mr. Nathaniel Benjafield's first-prize sow, "a very good and typical specimen of the breed," received the champion prize. Sow pigs made a better class than the young boars, the winners being level and neat. "Two useful pens of pigs could not be noticed owing to an absence of the typical white tail in one animal in each pen."

*Any Other Black Breed* was very sparsely represented, the four classes attracting but 13 entries, all from two breeders, of whom Mr. George Pettit was the more successful. They were an average show as compared with former years.

*Tamworths* came forward in about the same number as last year. With the exception of the sow class they have been seen to better advantage. Boars were a very moderate class, "the winner being only a fairly good pig." Boar pigs were not a good class; "the first-prize pen were typical of the breed; second and third prizes moderate." The sows, for which Messrs. Norman were first, were "a very good class indeed, the winner being a first-class specimen of the breed; all the winners were good, and we find the black hair and spots are gradually disappearing." Sow pigs made a fairly good class, the winners being an even pen of good colour and quality. A spotted pig rather spoilt the second pen, and the third pen, though very even, were short of hair.

#### POULTRY.

It is the opinion of the Judges that, regarded as a whole, the Poultry Section was superior to anything of the kind that has gone before. The high quality of the display was rendered the more remarkable on account of the late and disastrous breeding time. The prominence given to the strictly useful breeds as distinguished from the purely ornamental ones is

justified in the results, for the *flesh, egg, and early maturity* classes were specially well patronised and most creditably represented.

*Dorkings* were capital specimens, and there was a good entry in most of the classes, a considerable number of the exhibits being from the best yards of either colour. *Old English Game* were highly meritorious in the adult classes, and afforded excellent material for building up marketable and profitable strains of farmers' fowls. The chickens were less satisfactory; "the commercial essentials were all there, but juveniles of the 'old type' are by no means attractive." *Indian Game* exhibited a distinct advance. The quality of the adult exhibits of this fine table variety was excellent, and was exemplified in size, proportion, and beauty. The display of chickens, both cockerels and pullets, was beyond expectation,—“judged solely from a market standpoint, the whole 42 would have been a startling exhibition for any West-end poultry shop.” *Brahmas*, though less numerous than *Dorkings*, brought forward some winners of great merit. *Cochins* were highly meritorious so far as the winning birds were concerned. The chickens, however, were exceedingly backward. *Langshans* were represented by an exceptionally good lot of old birds, in nice condition. The chickens were well-grown and full of character. *Wyandottes*, chiefly Silvers, had suffered much in plumage, owing to the weather. The adult males were superior to the hens, the latter providing—save in the winners—nothing of conspicuous merit. The chickens were a typical lot, and included a few birds of exceptional promise. *Plymouth Rocks* had, in the old classes, some of the best specimens in the country; whilst the large entry of chickens worthily upheld the reputation of this variety for early maturity and hardihood. *Scotch Greys* were a failure, or nearly so, both in numbers and in quality. To account for this, it is suggested that breeders are transferring their affections to the *Plymouth Rocks*. *Minorcas* made up a very even, well-balanced lot,—altogether a fine collection. What faults there were had arisen from exposure, or as incidents of the breeding season, or might have been due to “fancy's exacting conditions.” *Andalusians* were quite a superior display. The adult birds were present in great force, and exhibited the highest degrees of beauty and usefulness. Chickens were neither so numerous nor so good. *Leghorns* in the adult classes showed, excepting the winners, nothing above medium quality. The chickens, mostly of the white variety, formed, on the other hand, one of the best sections of young birds in the Show. They were big smart showy birds, combining the triple qualifications of early development, capacity for laying, and beauty. *Hamburghs* were mostly



well shown, and several pens of chickens possessed high merit. The *Any Other Variety* section produced very few entries, but their quality was first class.

*Ducks* were fairly well represented. The distinctive characteristics of the *Aylesbury* and the *Pekin* were more conspicuously illustrated than for some years past, and the salutary influence of the Waterfowl Club was visibly exemplified. The successful exhibitors at Doncaster include some of the most prominent breeders and improvers of these two varieties. *Rouens* afforded signs of improvement in shape and quality, and the advance in size and in early maturity was specially noticeable in the young classes. The *Any Other Variety* section was disappointing alike in numbers and in quality. "There is certainly an encouraging opening for the improvement of that useful variety, the *Cayuga*, but we do not seem to have any pioneers of this species."

*Geese* furnished but small classes. These birds are naturally early moulters, and it is possible that their rough condition in June leads to the withholding of birds from exhibition at this period. Breeders are, however, reminded that "geese are judged less by feather than by size, shape, and symmetry—a circumstance that should conduce to larger entries at summer shows."

*Turkeys* made up a fairly representative display, the great improvement of late years in the *Bronze Turkey* being distinctly noticeable.

*Table Poultry*.—The Judge in this section (Mr. Edward Brown) has furnished the following details:—

Although there were two fewer classes provided this year than was the case at Plymouth, the entries show an increase of nine. This is entirely in the chicken classes, for there were two couples fewer of table ducks. And, further, the increase is found in the cross-bred sections, which were a failure twelve months ago, when they numbered only three entries for four classes, whereas at Doncaster there were 14 entries in two classes, and the crosses were fairly well varied. The number of pure breeds exhibited was 3 couples both at Plymouth and Doncaster. The section attracted considerable attention, and proved to be of great interest.

In order to make the Table Poultry department of as great value as possible, it was arranged that all the selected fowls should be weighed both before and after being killed, and the statistics given below may be very helpful in noting the possibilities of early maturity. Prior to making these selections every fowl washanded, and those with badly bent breast-bones were rejected, as well as others which indicated their unsuitability for presentation as table fowls. Some of the ducks were not as clean-plucked as could have been wished, but they were at an unsuitable age, having new feathers just shooting out.

The following are my notes on the respective classes, together with the weights of exhibits alive and dead:—<sup>1</sup>

<sup>1</sup> The live birds were weighed together; dead separately.

**Class 255.** Pair of cockerels of 1891, of any pure breed. In this class there were only four couples to compete, of which three were killed.

No.	Alive.	Dead.	Prize.
630.	Weight 9 $\frac{3}{4}$ lb. Indian Game, medium size, excellent type.	Weights (1), 4 lb. 15 oz.; (2) 3 lb. 15 oz.; very plump, well formed, good colour of flesh and skin.	} 1st
633.	12 $\frac{1}{2}$ lb. Dark Dorkings, rough and coarse, appeared to have been fattened and gone off.	(1) 4 lb. 15 oz.; (2) 6 lb. 2 oz.; large and fleshy, one spoiled by tumour on breast, and bent breast-bone.	
634.	10 lb. Dark Dorkings, nice-sized frames, but short of flesh; good legs and feet.	(1) 4 lb. 9 oz.; (2) 4 lb. 7 oz.; a little coarse in skin, but a nice pair and fairly plump.	} 2nd

**Class 256.** Pair of pullets of 1891, of any pure breed. Seven entries, all of which were sent, and six were selected for killing.

No.	Alive.	Dead.	Prize.
635.	9 $\frac{1}{2}$ lb. Plymouth Rocks; well forward, large, and handled well for this variety of fowl.	(1) 4 lb. 6 oz.; (2) 4 lb. 8 oz.; very thin clear skins, capital colour of flesh; a beautiful pair of chickens.	} 1st
636.	7 lb. 4 oz. Indian Game; well forward, nice shape, and very plump; medium size.	(1) 3 lb. 6 oz.; (2) 3 lb. 3 oz.; very good colour, and well fleshed.	
637.	8 lb. Silver Wyandottes, one wearing 1891 ring; good size and appearance.	(1) 3 lb. 10 oz.; (2) 3 lb. 13 oz.; nice shape, but deficient in quantity of flesh; fair quality of skin.	} h.c.
639.	6 lb. 10 oz. Dark Dorkings; very small, nice legs and feet.	(1) 3 lb. 4 oz.; (2) 2 lb. 7 oz.; very small, and coarse in skin.	} 2nd
640.	8 $\frac{1}{2}$ lb. Indian Game; tight-feathered, hard condition, very plump, excellent weight.	(1) 3 lb. 15 oz.; (2) 4 lb. 2 oz.; one slightly bent breast, and a little dark in skin, but very plump, and a fine pair.	
641.	9 $\frac{3}{4}$ lb. Dark Dorkings; well forward, good size, shape, and nice legs and feet.	(1) 4 lb. 4 oz.; (2) 4 lb. 9 oz.; did not fulfil promise; coarse and dark in skins.	} h.c.

**Class 257.** Pair of cockerels of 1891, of a first cross from any pure breeds. Six entries, but one not sent. Three pairs were selected for killing.

No.	Alive.	Dead.	Prize.
642.	7 lb. 4 oz. Indian Game and Dorking; fair size and plumpness, whitish legs.	(1) 3 lb. 3 oz.; (2) 3 lb. 8 oz.; a neat pair, plump and well formed, but dark in flesh.	} 3rd
644.	10 $\frac{3}{4}$ lb. Silver Grey Dorking and Indian Game; second biggest birds in the chicken classes; fleshy, and good shape.	(1) 5 lb. 5 oz.; (2) 4 lb. 12 oz.; very long in body, rather heavy thighs, somewhat coarse in skin, but a fine pair of chickens.	
646.	9 lb. 6 oz. Indian Game and Coloured Dorking; large, well forward chickens, handled well, good legs and feet.	(1) 4 lb. 10 oz.; (2) 4 lb. 4 oz.; capital size, very plump indeed, lovely colour of flesh and skin, white legs.	} 1st
647.	Indian Game and Coloured Dorking; the largest birds in the chicken classes, but not selected on account of badly bent breasts. They were, however, killed by mistake.	(1) 5 lb. 8 oz.; (2) 5 lb. 12 oz.; very coarse in skin, and spoiled by bent breast-bones. They were also yellow in legs.	

Class 258. Pair of pullets of 1891, of a first cross from any pure breeds. In this exceedingly good class were eight entries, of which only five pairs were sent. The entire class was selected for killing.

No.	Alive.	Dead.	Prize.
648.	7½ lb. Langshan and Indian Game; smallish but close and compact, slightly feathered legs.	(1) 3 lb. 2 oz.; (2) 3 lb. 7 oz.; thin skins and very plump, but dark in colour.	3rd
651.	6 lb. 12 oz. Dorking and Game or Brahma was given as the cross—evidently the latter, from the slightly feathered legs.	(1) 3 lb. 1 oz.; (2) 2 lb. 15 oz.; coarse in skin and flesh.	h.c.
652.	7½ lb. Silver Grey Dorking and Dark Brahma, small but neat, well formed, slightly feathered legs.	(1) 3 lb. 3 oz.; (2) 3 lb. 6 oz.; small, fairly fleshed, rather coarse in skin.	
653.	9 lb. Silver Grey Dorking and Indian Game; good size, capital shape, well developed, one slightly bent in breast-bone.	(1) 4 lb. 5 oz.; (2) 3 lb. 11 oz.; large and very plump, one beautiful in flesh and skin, other bruised on breast and with bent keel.	2nd
655.	9 lb. 6 oz. Indian Game and Coloured Dorking; large and good size, fine shape, one with yellow and other with dark legs.	(1) 4 lb. 12 oz.; (2) 3 lb. 15 oz.; long in bodies, large, and good shape, thin transparent skins, fine flesh, but slightly dark on breasts.	1st

Class 275. Pair of ducklings of 1891, of any pure breed. There were five entries, of which four couples were on exhibition.

No.	Alive.	Dead.	Prize.
765.	10¾ lb. Aylesburys; of good type, shapely, and good heads.	(1) 4 lb. 7 oz.; (2) 5 lb. 4 oz.; not very even in colour, moderate in flesh development.	h.c.
766.	10¾ lb. Aylesburys; of similar character, handled better.	(1) 5 lb. 4 oz.; (2) 4 lb. 10 oz.; nice colour, good bodies.	2nd
767.	12½ lb. Aylesburys; very large and well fleshed, pale in beaks, apparently been fattened.	(1) 5 lb. 7 oz.; (2) 6 lb. 2 oz.; wonderfully forward, and of excellent colour, best in duckling classes.	1st
768.	9¾ lb. Pekins; of nice quality.	(1) 4 lb. 9 oz.; (2) 4 lb. 1 oz.; like all Pekins, yellow but even, rather bony.	3rd

Class 276. Pair of ducklings of 1891, of a first cross from any pure breeds. Six entries, one absent.

No.	Alive.	Dead.	Prize.
770.	9 lb. 10 oz. Rouen and Aylesbury; not well developed.	(1) 4 lb. 8 oz.; (2) 4 lb. 10 oz.; coarse in skin.	
771.	9 lb. 6 oz. Rouen and Aylesbury; one white and one coloured in plumage.	(1) 4 lb. 3 oz.; (2) 4 lb. 5 oz.; coarse in skin.	
772.	10 lb. Rouen and Pekin; dark plumage and bills, well developed.	(1) 4 lb. 2 oz.; (2) 4 lb. 14 oz.; disappointing, rough and coarse.	3rd
773.	11 lb. 2 oz. Pekin and Aylesbury; large and well formed.	(1) 5 lb. 8 oz.; (2) 5 lb. 2 oz.; very massive, well fleshed, good colour, but coarse in skin.	2nd

	<i>Alive.</i>		<i>Dead.</i>	<i>Prize.</i>
774.	8 lb. 12 oz. Pekin and Aylesbury; small compact bodies, heavy for size.	(1) 3 lb. 13 oz.; (2) 3 lb. 12 oz.;	lovely colour, well fleshed, compact, and a perfect pair but for size; quality splendid.)	} 1st

It will be of interest to show the loss of weight of all the birds killed, but as it was difficult to arrange for this to be done individually, the following figures are for pairs:—

No.	Breed	Alive		Dead		Loss oz.
		lb.	oz.	lb.	oz.	
630.	Indian Game . . . . .	9	12	8	14	14
633.	Dark Dorkings . . . . .	12	8	11	1	23
634.	Dark Dorkings . . . . .	10	0	9	0	16
635.	Plymouth Rocks . . . . .	9	8	8	14	10
636.	Indian Game . . . . .	7	4	6	9	11
637.	Silver Wyandottes . . . . .	8	0	7	7	9
639.	Dark Dorkings . . . . .	6	10	5	11	15
640.	Indian Game . . . . .	8	8	8	1	7
641.	Dark Dorkings . . . . .	9	12	8	13	15
642.	Indian Game and Dorking . . . . .	7	4	6	11	9
644.	Dorking and Indian Game . . . . .	10	12	10	1	11
646.	Indian Game and Dorking . . . . .	9	6	8	14	8
648.	Langshan and Indian Game . . . . .	7	8	6	9	15
651.	Dorking and Brahma . . . . .	6	12	6	0	12
652.	Dorking and Brahma . . . . .	7	4	6	9	11
653.	Dorking and Indian Game . . . . .	9	0	8	0	16
655.	Indian Game and Dorking . . . . .	9	6	8	11	11
765.	Aylesbury ducks . . . . .	10	12	9	11	17
766.	Aylesbury ducks . . . . .	10	12	9	14	14
767.	Aylesbury ducks . . . . .	12	8	11	9	15
768.	Pekin . . . . .	9	12	8	10	18
770.	Rouen and Aylesbury . . . . .	9	10	9	2	8
771.	Rouen and Aylesbury . . . . .	9	6	8	8	14
772.	Rouen and Pekin . . . . .	10	0	9	0	16
773.	Pekin and Aylesbury . . . . .	11	2	10	10	8
774.	Pekin and Aylesbury . . . . .	8	12	7	9	19

It would be unadvisable to draw any general inference from the above statistics, because, as the fowls were not drawn, the loss was merely that of feathers and lower limbs. Still, it is interesting to note how small the loss was with Indian Game and Indian Game crosses.

In conclusion, I would suggest to the Council of the Royal Agricultural Society that two or more classes for fowls sent dead would be of great service, and should be popular, filling a niche that is left open by the present arrangement. As it is essential that fattened fowls should be killed where they are fed, in that they rapidly lose weight and condition if sent alive, no encouragement is given to those who fatten for market. Such a class might be for capons or non-caponised fowls. I should further like to suggest that the age of all fowls be stated, for some of the best fowls in my classes at the Doncaster Show were just about three months old, while others which did not look nearly so well were much older.

#### CHEESE.

The 56 entries of cheese fell a score short of the number staged at Plymouth. Last year, in the three staple classes of Cheddar, Cheshire, and Stilton, the cheeses had to be those of the

preceding year's make; on this occasion they were to have been made in the current year. *Cheddar* furnished a small show of only seven entries, no doubt owing to the backwardness of the season. One lot was disqualified on account of its weighing only  $45\frac{3}{4}$  lb. instead of 50 lb. per cheese. Of *Cheshire* there were 10 entries, and the general quality was fair, many dairies being rather soft. *Stilton*, six entries, was a fair show for the time of year; the first prize was a very good entry, both in quality and in flavour. The effort to encourage the local makes of cheese in Yorkshire did not meet with much response, there being only two entries of *Cotherstone* and six of *Wensleydale*. In both cases the display was of so poor a quality that the first prize was withheld. *Cheeses of any other British make* were of fair quality, and compared favourably with some of the select classes. *Cream Cheeses* were a limited show, and the hot weather affected some of the exhibits. Of *British Soft Cheese* there were only two lots, and neither was good enough for a first prize.

Regarded as a whole, the exhibition of cheese must be looked upon as a poor one—a circumstance of which the withholding of three of the first prizes is sufficiently significant.

#### BUTTER.

The entries were about the same number as last year, although the classes were two less, no provision being made at Doncaster for scalded cream butter and whey butter, which together attracted three dozen entries at Plymouth.

Fresh butter, free from salt, was not a fine class. The exhibits had evidently suffered from having been made four or five days before being judged,—“this invariably affects a pure butter with no salt.” Class 290 comprised 92 entries, and, as a whole, the quality was good, as, being slightly salted, the flavour was preserved. Most of the entries of salt butter had suffered through not having been properly protected. “We would strongly advise the placing of these butters in well-glazed crocks, and then kept covered with an inch-and-a-half of strong brine.”

#### CIDER AND PERRY.

The entries were only half as numerous as at Plymouth. Still, the 28 entries of cider showed the interest the competition excited though it took place in a non-cider country. Of these entries, Devonshire contributed 10, Herefordshire 10, Gloucestershire five, and Somerset three, the laurels going to Gloucestershire.

There were but very few really good samples, and only one of an exceptional character, Mr. Henry Thomson's. "This was exhibited in two classes, cask and bottle, and bore evidence of judgment in the selection of fruit and in the after-treatment. Although rather crude in some respects, it contained all the elements of a really fine cider, and was well worthy of a first award in both classes."

The old bottled cider class was so inferior that the Judge could not recommend the award of any of the prizes. "The samples were without flavour; several were in bad condition, and had completely lost what little pretensions to character they originally possessed."

"If," remarks the Judge, "cider-growers generally would but discard local tastes and local prejudices, and study to raise the quality of British cider, we should soon find a greater national demand spring up, which would give an impetus to fruit-growing, especially to the production of superior apples, and furnish a substitute for some of the light wines now so freely imported at great cost to the country. As to the comparison of good honest cider with *cheap* champagne, every impartial critic would incline to the opinion that our own product is by far the best, and certainly the most economical. Despite the more sunny climates of some other apple-growing countries, we have in our soil and temperature all necessary conditions for the production of the finest cider the world can provide. But to obtain this result it is urgently necessary to use only the best fruit grown on suitable soil."

There were but four exhibits of bottled perry—"on the whole fairly good." The first and second awards were given to excellent samples, from quite opposite descriptions of fruit.

#### JAMS AND PRESERVED FRUITS.

In the Report of the Plymouth Meeting it was stated respecting this section, "The entries in these classes were disappointingly few, but the Council have thought it best to continue the prizes for another year, in the hope that more competitors may be induced to come forward and to take an interest in jam-making." Unfortunately, the entries at Doncaster—only four in all—were less than half the number last year, whilst two of the classes were entirely vacant. All the entries were placed by the Judge, who reports that the quality of the exhibits leaves nothing to be desired, and shows a vast improvement as compared with the exhibits at the Jubilee Show at Windsor.

## HIVES AND HONEY.

The four Judges (the Rev. J. F. Boddier, Mr. W. B. Carr, Mr. Jesse Garratt, and Mr. Walter Martin), who officiated in this section, have sent the following report:—

The Bee Department of the Show was this year admirably laid out, and it would be difficult to suggest any improvement in the method of displaying either the honey or the appliances.

The plan followed had the double advantage of allowing for the convenient inspection of the various articles by bee-keepers and others specially interested, while not interfering with free locomotion on the part of the great body of visitors. The close proximity of the lecturing tent was also very advantageous: indeed the whole arrangements of the department were most creditable to the officials who had them in charge.

The entries in the more important classes were considerably better than last year, notably in those for collections of bee appliances, observatory hives stocked with bees, and useful inventions: the exhibits in these three classes being about double the number staged at Plymouth. Referring to Class 301 for observatory hives, we would suggest the introduction in next year's schedule of a rule making it compulsory that all hives exhibited with living bees shall have facilities for and be so staged so that the bees shall have free egress and ingress therefrom. This would do away with the almost cruel practice of staging hives in which the bees are imprisoned during the whole time the Show continues. Several hives of the latter type were shown at Doncaster, and as usual caused the death of some hundreds of the bees confined therein.

While bearing testimony to the general excellence of the workmanship in most of the goods shown, we may confine our remarks to the consideration of such articles in each class as possess some plain, or original, or improvement on what has been shown before. In this connection it was noticeable that the terribly severe winter of 1899-00, and the consequent heavy mortality among bees, has had some influence in encouraging the manufacture of hives with a loose outer case, for the protection of bees against the weather, both First and Second Prizes in Class 302 "For the best hive for general use" being awarded to hives of this type. In Class 304, for Honey Extractors, the machine taking first place had attached to it—for use if desired—a novelty in the shape of an "extra chain bearing" similar to those used on cycling machines, but we doubt if the advantage gained is worth the extra cost entailed, many practical men preferring the simple and direct action of a handle attached to the central rod of the revolving cage. Class 305 for section racks produced eight entries, the highest award being given to one with hanging-frames in which the sections were worked, instead of the ordinary rack. The idea is not a new one, but the box shown claimed to remedy the defects of previous ones of the same type.

In the class for rapid-feeders, some good ones were shown, and we are pleased to observe that makers are still endeavouring to improve this useful adjunct to the Apiary. In Class 312 for useful inventions, there were fifteen entries, the most important, from a commercial point of view, being a hive in which the several parts are held together by a twin-dovetail joint almost entirely without the use of nails. The idea of the designer is to have these hives cut by machinery and sent out in the flat, so that bee-keepers may build up their hives at home, and thereby save cost of labour and carriage. There is no doubt that a firm and rigid joint is secured by the stout angle-

pieces on which the twin-dovetail is cut, and some ingenuity is displayed in the adaptation of this angle-piece to the various parts.

The further development of this idea will be watched with some interest, proposing, as it does, to make a radical change in hive manufacture. A silver medal was awarded to this exhibit, and also to the section box mentioned in Class 305. A new frame, with its top bar divided nearly, but not quite, through the wood, so that the upper side of the bar affords no lodgment for the wax moth, received a bronze medal.

Coming to the Honey Classes, the entries were numerous, but the lateness of the season and the early date on which the Show was held, had a somewhat adverse effect on the quantity staged, and the compilers of the schedule showed their wisdom in admitting honey of previous years in competition with that of the current season. The difficulty, however, of judging old and new honey in the same class makes it advisable to consider the desirability of separate classes for each, so that they may be judged on their respective merits.

It was gratifying to notice the amount of interest taken in the Bee Department by farmers and the general public, as testified by the numbers passing through this portion of the Show, and the large audiences attending the lectures in the bee-tent.

#### THE BUTTER-MAKING COMPETITIONS.

The Dairy was, as usual, most complete in its arrangements for the competition of butter-makers, though, as the Judges remark, "the handsome prizes offered, amounting to 64*l.*, were worthy of a far larger number of entries, the more especially as no entry fee is charged." They add, "When new appliances are provided by makers, they should very thoroughly prepare them for use. It takes several days to do this, and some of the workers laboured under the disadvantage arising from its not being done."

Special care was taken to supply the competitors with portions of cream identical in quantity and quality, as, unless this is done, a very important part of the test—namely, the weight of butter produced—is liable to be defective. In this way 14 lb. of cream was given to each competitor.

In the first competition—open to the United Kingdom—there were ten candidates (eight of whom were females), and all competed. The second competition was for female members of a farmer's family not in service or working for wages, and in this case thirteen competed. The third competition, restricted to dairymaids in service who had never won a prize exceeding 1*l.* in value at any competition, and the fourth competition, for dairymaids residing in the county of York, attracted but three entries each.

In all the classes "the work was generally good." The first and second prize winners (Miss Evelina E. Fritchley and Mrs. C. L. Horton) in the second competition "did exceedingly good work."



The lectures and demonstrations given daily by Miss Maidment were a source of attraction to large numbers of visitors, whilst the scientific and practical discourses delivered by Dr. Voelcker and Mr. Rigby were listened to with great interest.

#### THE HORSE-SHOEING COMPETITIONS.

These contests were limited to shoeing-smiths in the county of York, there being 14 competitors in Class 1 (Hunters) and 12 competitors in Class 2 (Agricultural Horses), though a larger muster might have been expected.

Some excellent work was done in the Hunter class. The time occupied in taking off a fore-shoe, preparing the foot, making and fitting one fore-shoe and one hind-shoe and setting on the former, varied from 29 to 39 minutes. The first-prize winner, a really excellent workman, and, as the *vivá voce* examination afterwards proved, a man with a good knowledge of the anatomy of the horse's foot, made the best record as to time. The 2nd, 3rd, and 5th prize winners passed a good *vivá voce* examination, whilst the 4th prize winner and the two highly commended competitors, though good workmen, knew but little of the structure of the foot.

In the Agricultural Horses class the work was not exceptionally good. The time varied from 26 to 36 minutes. In the *vivá voce* examination three of the prize winners showed a fair knowledge of the foot, but the others examined knew nothing of its structure.

"In recent years," say the Judges, "a very decided improvement has taken place as to the treatment of the sole and frog. They are not now pared and reduced in strength as they used to be, but there is still far too much rasping of the nail of the foot after the shoe has been put on. We noticed one competitor who, after rasping and filing, finished up by polishing the crust with emery-paper."

Owing to the excellent selection of horses made by the Assistant Steward in charge (Mr. Claude Pilkington), their feet were uniformly good, thus giving every competitor the same chance to show his skill.

#### CONCLUSION.

Yorkshire has been well termed "an epitome of England," and the Society may look back with satisfaction upon its Fifth Meeting in our largest county. It was a fine-weather Meeting, and, thanks to the hearty co-operation of the Local Committee

and the Doncaster Agricultural Society, it presented many pleasant and agreeable features. If there was one attraction that may on this occasion claim to have been supreme, it was the Horse Ring. That this should have been so is what might have been anticipated from the associations of the district. The dense crowds of well-behaved and well-dressed people who literally hemmed in the great ring—especially on the Wednesday and the Thursday—afforded an earnest demonstration of the love which an Englishman has for a horse. Whatever other claims it may have to live in the memory of those who visited it, the Doncaster Show will long be remembered for its great gathering of Hunters, and its magnificent display of Hackneys and Shires.

W. FREAM.

---

## THE TRIALS OF THRESHING MACHINES AT DONCASTER.

At the Cardiff Meeting of the Society, in 1872, competitive trials were held for two classes of Threshing Machines—

(1.) For the best Combined Portable Threshing and Finishing Machine, to be worked by steam, and adapted for the preparation of corn for market.

(2.) For the best Combined Portable Threshing Machine, to be worked by steam, which has no corn screen or other apparatus for sorting the grain for market.

In each of these classes there were no less than fifteen competitors.

In the period which has elapsed since these trials, the second class of machine has practically disappeared. The Council of the Society, therefore, in arranging for trials of Threshing Machines for 1891 decided that there should be only one class of machine, viz., Finishing Machines, and they offered first, second, and third prizes of 100*l.*, 50*l.*, and 25*l.* for the best “Combined Portable Threshing and Finishing Machine, to be worked by steam, and adapted to the preparation of corn for market (the width not to exceed 4 ft. 8 in. inside the frame, and the width of drum not to exceed 4 ft. 6 in.)”

Whilst at the former trials no restriction was made as to the size of the machine—the length of drum varying from 52½ in. to 57 in.—it was decided that on the present occasion the length of drum was not to exceed 4 ft. 6 in., within which dimension

all machines used in this country would be included, and which would also lead practically to uniformity in size of the machines.

The special features of merit in the machines were fully discussed and the points of merit to be awarded for them were decided upon; and copies of these, together with the general conditions, were published in April 1890, the entries being made returnable on August 1, 1890.

The points representing perfection were stated in the regulations as follows:—

Clean threshing . . . . .	30
Clean shaking . . . . .	10
Cavings free from corn . . . . .	5
Chaff free from corn . . . . .	6
Chaff free from cavings, seeds, and dirt . . . . .	5
<sup>1</sup> Straw unbroken . . . . .	5
Corn uninjured . . . . .	15
Cleanness of delivery from machines . . . . .	2
(i.e., absence of lodgment).	
<sup>1</sup> Perfection of finishing . . . . .	5
(i.e., screening or sorting).	
Construction and convenience of working . . . . .	6
Power in proportion to results . . . . .	5
Economy of attendance . . . . .	4
Price . . . . .	2
	—
	100

<sup>1</sup> In threshing the barley and oats, the points of straw unbroken will not be given, but will be added to the points allowed for perfection of finishing, making the number 10.

The trials were to be with wheat, barley and oats, and “those machines which appear to the Judges of sufficient merit, after preliminary trials with both wheat and barley, will be run for a final trial, of not less than one hour with wheat, one hour with barley, and half-an-hour with oats, in order to enable a more correct and satisfactory judgment of their merits to be arrived at.”

Nine exhibitors originally entered for this competition, but of this number four eventually withdrew, leaving five machines to compete. The following is a list of the competing firms: James Coultas; E. Foden, Sons, & Co.; W. Foster & Co.; Gibbons & Robinson; W. Tasker & Sons.

The arrangements for the trials were very similar to those at Cardiff. A large temporary shed was erected, affording sufficient space in its length to allow of three machines being got into place for working simultaneously, as also for a fourth machine for re-threshing the straw and cavings; this machine, with combined trusser, together with the engine for working it, was kindly lent by Messrs. Hornsby, of Grantham. The width

of the shed allowed the delivery of the straw from the machines under trial, and its transport for re-threshing, to take place under cover. Along the length of the shed, in front of same, a line of rails was fixed. On this were mounted on trolleys two engines provided by Messrs. Davey, Paxman & Co., of Colchester, for driving the machines under trial. One engine (a single-cylinder engine) was used when necessary for the preliminary trial, the other (a compound engine of the Newcastle Prize type) was connected by a coupling shaft to the dynamometer, which was also mounted on the same trolley, and through which the threshing machine under trial was driven, the exact amount of power taken during the trial being thereby measured. The trolleys could be readily moved to and fro by a rope and crab into any required position for driving the machines.

At the entrance to the shed was a large weigh-bridge, lent by Messrs. Pooley & Sons, on which each cartload of corn was weighed as it came in from the stack. A small portable weighing machine was used for weighing the threshed corn. The stacks of corn were close to the shed, and were protected by rick cloths. Fortunately the weather during the trials was all that could be desired; but it would be advisable in future trials to get all the ricks under cover, so as to avoid cartage through the open, as, had the weather been wet, there must have either been an interruption to the work, or a want of uniformity in the corn served to the machines. The trials commenced on Tuesday, June 16, the Judges being Dr. W. Anderson, C.E., F.R.S., Colonel Grantham, and Mr. S. Rowlandson.

The order (determined by lot) in which the machines were tried was as follows:—(1) Foster, No. 4,156; (2) Tasker, No. 4,144; (3) Coultas, No. 607; (4) Gibbons, No. 4,142; (5) Foden, No. 4,152. This order is adhered to throughout the tabular statements of the results of the trials.

An examination of these machines showed that they would all be capable of getting through their preliminary trials; and as there was an ample supply of corn, a slight deviation in procedure from that originally contemplated was adopted, it being decided that each machine, having got through the exhibitors' preliminary trial, should at once go on to the hour's trial in wheat, to be followed immediately by the runs with barley and oats. This effected a very considerable saving of time in shifting from one machine to another.

It may be noted, in comparing the present trials with those of 1872, that whereas at Cardiff a given quantity of corn was weighed out to the various machines for their several runs, on the present occasion the duration of the trial was made the

uniform element, being one hour each for wheat and for barley, and half-an-hour for oats, the result being that each trial dealt with more than three times the amount of corn used at Cardiff.

As soon as the machine to be tested was got into place, it was first run idle up to the regulation belt speed of 1.884 feet per minute. A preliminary trial of fifty sheaves or thereabouts was allowed to each machine to enable the exhibitor to complete all adjustments for working to the best advantage. The results were not recorded by the Judges, though the run afforded them the opportunity of observing special features to be noted during the official trials which followed. As soon as the exhibitor had completed his adjustments, and the machine was working satisfactorily, he declared the number of attendants necessary for the trials, which in every case, save one, was four, the exception being Messrs. Foden's machine, worked by three attendants. It should be here mentioned that the Society found men for putting the corn on to the stages of the machines, and for clearing away the full sacks, the straw and the cavings. The exhibitors' men fed the machine, attended to the spouts, and looked generally to the working parts. It had been suggested, probably as a consequence of a suggestion in the Cardiff report, that at future trials it would be well that the feeding of all the machines should be done by the same man. No doubt this would be interesting, and, if it were done, the results probably might be very different; but it is a condition which it would be well-nigh impossible to carry out fairly. Obviously, an inexperienced feeder could not be employed, and an experienced one must have gained his knowledge in working a machine which, if not of the same make as one of those he would have to work in the trial, must have been of a type more closely resembling one machine than another. Consequently, with every desire to deal impartially, he could not but work more efficiently on the machine more closely resembling the one he had been used to. There is, no doubt, a very great difference in the way machines are fed, and with this fact no one should be better acquainted than the makers; it should rest with them to put the best feeders they can procure to do their work.

The machine, having quite cleared itself of corn, was stopped, and, after everything was seen to be in proper order, it was again started. So soon as it had acquired an uniform speed the signal was given for the feeding to commence, the time of such start being noted. Feeding was continued for the specified time and then stopped, after which the machine was allowed to run idle for ten minutes to clear itself. During the trials, notes were taken by the Judges of all that occurred; not only were the

samples of grain examined, but the straw, as it came from the machine, was carefully scrutinised to see to what extent it was broken. The cavings also underwent frequent examination with reference to grain passed over with them.

The corn in the sheaf was, as already stated, weighed on its way to the machine, whilst any corn not used within the specified time was weighed back, and the net weight thus obtained was taken. The various samples of corn delivered by the machine were weighed separately, as was also any grain recovered from re-threshing. During the whole of the trial the dynamometer was keeping its record of the power used, and afterwards the machine was run idle and the power taken in that condition was ascertained. From these various observations the accompanying tables have been compiled by the Society's Engineers.

Table I. (page 488) gives in a tabular form a brief description of the various machines.

Table II. (page 489) gives a record of the observations taken during the official trial runs, together with the deductions made from them.

*Foster's Machine.*—Messrs. Foster were the first to start, and having got through their preliminary trial, they at once proceeded to their hour's run of wheat. The total wheat in sheaf served on to the machine was 6,826 lb., and this was threshed without any interruption during the run; the products in grain were 2,061 lb. of firsts, 100 lb. of seconds, and 17 lb. of thirds. On re-threshing the straw and cavings, 24.5 lb. of grain were recovered. The horse-power expended was 9.01.

Following on with their barley trial of an hour, 5,472 lb. of corn in the sheaf were served out, and the products in grain were 2,544.5 lb. of firsts, 138.5 lb. of seconds, 18.25 lb. of thirds, and on re-threshing 36.75 lb. were recovered. During this run a slight interruption occurred owing to the fly-wheel of the engine getting loose; but as this was in no wise connected with the working of the machine, the full 8½ minutes stoppage was allowed. The horse-power measured was 8.4.

The trial with oats followed, in which 3,708 lb. of sheaf corn were served out, and the products were 1,501 lb. of firsts, 34.25 lb. of seconds, 11.75 lb. of thirds, and 9 lb. recovered by re-threshing. The horse-power was 9.5. The power taken by the machine running idle was 4.53 h.p.

The first trial in wheat having been made from the upper portion of the rick, a second run of an hour with this machine was made in wheat on June 19, with the following result: corn in sheaf served out, 5,125 lb.; products, 1,982.75 lb. of firsts, 38.25 lb. of seconds, 9.5 lb. of thirds. In this trial there was no

re-threshing, but assuming the amount recovered to be in the same proportion as in the first trial, there is a gain in the yield of grain as compared with the weight of sheaf corn.

The best corn in the wheat trials was too much broken, but the straw and cavings were clean threshed. The machine made a good sample of the barley, but did not separate the seconds from the best corn in the oats as well as it might have done.

*Tasker's Machine.*—Following on Messrs. Foster's trials, the wheat trial of Messrs. Tasker was taken on the evening of the same day. The machine having been adjusted, 6,668 lb. of sheaf corn were served out, the products being 2,518·5 lb. of firsts, 160·25 lb. of seconds, 43 lb. of thirds, and recovered from re-threshing, 12·25 lb. The horse-power taken was 7·27.

On the next morning the trial of this machine was resumed with barley, when 6,008 lb. of sheaf corn were served out, the products being 2,629·5 lb. of firsts, 327·5 lb. of seconds, 59 lb. of thirds, and recovered from re-threshing, 26·25 lb. The horse-power was 7·68.

In the half-hour's run with oats which followed, 3,052 lb. of sheaf corn were served out, the products being 1,166·5 lb. of firsts, 36·25 lb. of seconds, 12½ lb. of thirds, and recovered from re-threshing, 3¼ lb. Horse-power 6·95. The power taken to run idle was 4·0 h.p.

This machine separated the firsts, seconds, and thirds very regularly. The straw and cavings were clean threshed, but in the barley too much corn was left in the cavings. The oats were very well threshed.

*Coultas's Machine.*—The next machine to be tried was that of Mr. Coultas. The sheaf corn served out during the hour's run was 6,972 lb., the grain products being 2,619·25 lb. of firsts, 31·5 lb. of seconds, 16·75 lb. of thirds, and 8·5 lb. of fourths; recovered from re-threshing, 23½ lb. The power taken was 8·15 h.p.

During the barley trial of one hour, 3,488 lb. of sheaf corn were served out, and the grain products were 1,587 lb. of firsts, 107 lb. of seconds, 51 lb. of thirds, 18·5 lb. of fourths, and recovered from re-threshing 33·5 lb. The power taken was 7·66 h.p.

For the half-hour run with oats, 1,692 lb. of sheaf corn were served out, and the yield in grain was 801 lb. of firsts, 27 lb. of seconds, 12 lb. of thirds, 9 lb. of fourths, and recovered by re-threshing, 7·25 lb. The power taken was 8·42 h.p.

In all these runs the feeding and consequent running of the machine were most irregular. Far too much of the best corn was left amongst the seconds and thirds. The thirds nearly equalled the seconds; in fact, all the corn was badly separated in the wheat trials. The barley was not as clean threshed as it

RESULTS OF TRIALS OF THRESHING MACHINES, DONCASTER, 1891.  
TABLE I.—Construction, Speeds, Surfaces, Speed and Drum Relations.

Cata- logue No.	1	2	3	4	5	6	7	Shakers			Caving riddles					
								Nominal power	Cata- logue price	Revolutions per minute	Beaters	How worked	Stroke	Length	Width	Stroke
4156	Foster, W., & Co.	8	£ 155	cwt. 75	in. 22.0	ft. in. 4 5	1,000	8 Goucher	2 cranks	in. ft. 45 = 375	ft. in. 5 6	3 10.5	in. ft. 30 = 25	sq. ft. 21.2		
4144	Tasker, W., & Sons	8	140	86	21.5	4 5.75	1,065	8 Grays	2 cranks	50 = 416	4 9	4 2	45 = 375	19.75		
607	Caultas, Jas.	8	140	72	22.0	4 5	1,018	8 Grays	2 cranks	50 = 416	6 0	4 2	40 = 333	25.0		
4142	Gibbons & Robinson	8	125	75	23.0	4 5	1,032	8 Goucher	1 crank	30 = 25	5 0	3 9.5	30 = 25	19.0		
4152	Folien, E., Sons, & Co.	8	145	76	22.0	4 5.5	1,032	8 Goucher	2 cranks	50 = 416	5 1	4 0	30 = 25	20.3		
—	Mean	—	—	77.5	—	—	1,029	—	—	—	—	—	—	21.0		

Name of maker	Dressing riddles <sup>1</sup>						Fan, 1st blast		Fan, 2nd blast		Finishing riddles				Screen	
	Length	Width	Area	Stroke	How worked	Diameter	Diameter	Diameter	Length	Width	Area	How worked	Length	Width	Area	Name
Foster, W., & Co.	ft. in. 2 10.5	ft. in. 1 6.5	sq. ft. 4.42	in. ft. 3.0 = 25	Riddle crank	ft. in. 1 8	ft. in. 1 8	ft. in. 1 4	ft. in. 2 4.25	3.13	Riddle crank	ft. in. 1 10	ft. in. 2 6	4.58	Riddle crank	Rainforth
Tasker, W., & Sons	2 9	1 8	4.57	4.5 = 375	Riddle crank	Nil	Nil	1 4	1 10	2.43	Riddle crank	1 4	2 11	5.0	Riddle crank	Penny
Caultas, Jas.	3 11	1 7	6.33	4.0 = 333	Riddle crank	1 8	1 3	1 75	No finishing sieves used	—	Shaker crank	1 75	—	—	Shaker crank	Penny
Gibbons & Robinson	4 0	1 7	6.33	3.0 = 25	Shaker crank	1 8	1 3	—	—	—	—	—	—	—	—	—
Folien, E., Sons, & Co.	4 2.5	1 10	7.72	3.0 = 25	Riddle crank	2 6	1 8	—	—	—	—	—	—	—	—	—
Mean	—	—	5.83	—	Riddle crank	—	—	—	—	—	—	—	—	—	—	—

<sup>1</sup> The dimensions here given are those of the grain sieve.



**RESULTS OF TRIALS OF THRESHING MACHINES, DONCASTER, 1891.**  
**TABLE II.—Results of Trials.**

No.	1	2	3	4	5	6	7	8	9	10	11	12	13	14	15	16	17	18
Cate- logue No.	Name of maker	Descrip- tion of corn threshed	Weight of corn in sheaf served out	Time run- ning per minute	Corn in sheaf threshed per minute	Delivered into sacks				From second thresh- ing	Total grain	Yield or ratio of weight of grain to weight of corn in sheaf threshed	Grain per min- ute	Horse- power	Foot pounds per min. of sheaf corn threshed	H.P. whole ma- chine	H.P. drum and fans	H.P. H.P. only
						First	Seconds	Thirds	Fourths									
4156	Foster & Co.	Wheat	lb. 6,286	min. 60	lb. 1137	lb. 2,061.0	lb. 100	lb. 17	lb. —	lb. 24.5	lb. 2,292.5	per cent. 32.4	lb. 367	9.01	2,601	4.53	—	2.51
	"	Barley	5,472	60	91.2	2,544.5	138.5	18.25	—	36.75	2,738.0	50.1	45.7	8.4	3,040	—	—	—
	"	Oats	3,708	30	123.6	1,501.0	34.25	11.75	—	9.0	1,556.0	41.8	51.8	9.5	2,530	—	—	—
	"	Final	5,125	27.5	186.3	1,982.7	38.25	9.5	—	—	2,030.45	39.6	74.6	—	—	—	—	—
4144	Mean													2,722				
	Tasker & Sons	Wheat	6,068	60	111.1	2,578.5	169.25	43.0	—	12.25	2,721.75	48.0	45.3	7.28	2,628	4.0	—	—
	"	Barley	6,908	60	100.1	2,629.5	327.5	59.0	—	26.25	3,042.25	50.6	50.7	7.68	2,534	—	—	—
	"	Oats	3,952	30	101.7	1,166.5	36.25	12.5	—	3.25	1,218.5	39.9	40.6	6.95	2,881	—	—	—
607	Mean													2,681				
	Conitas	Wheat	6,972	60	116.2	2,619.25	31.5	16.75	—	23.5	2,699.5	38.7	44.8	8.47	2,405	5.47	—	—
	"	Barley	3,488	60	68.1	1,587.0	107.0	51.0	18.5	33.5	1,797.0	51.5	29.6	7.66	4,360	—	—	—
	"	Oats	1,692	30	56.1	801.0	27.0	12.0	9.0	7.25	856.25	50.6	28.2	8.42	4,320	—	—	—
4142	Mean													3,863				
	Gibbons & Robinson	Wheat	7,732	60	128.8	2,849.5	76.0	54.5	—	13.25	2,992.25	38.7	49.8	11.05	2,835	5.89	4.69	3.67
	"	Barley	6,476	60	112.4	3,085.5	186.5	74.5	—	32.75	3,379.5	62.2	51.3	10.04	3,125	—	—	—
	"	Oats	2,996	30	99.9	1,135.5	25.25	16.5	—	5.0	1,182.25	39.2	39.8	10.25	3,382	—	—	—
4152	Mean													3,114				
	Gibbons & Robinson	Wheat	5,852	35.5	164.0	2,190.5	29.75	21.25	—	—	2,211.5	38.3	63.2	10.04	2,020	—	—	—
	"	Barley	8,141	60	140.4	3,102.5	101.0	21.75	—	—	3,244.5	39.9	55.9	10.44	2,460	5.79	4.47	2.41
	"	Oats	5,812	60	96.8	2,720.0	105.5	24.0	—	23.25	2,872.75	49.7	48.0	10.07	3,441	—	—	—
4152	Mean													2,428				
	Foden & Sons	Wheat	4,626	30	151.2	1,712.25	30.25	11.0	—	7.5	1,761.0	38.1	58.7	11.35	2,428	—	—	—
	"	Barley	6,387	27.5	230.1	2,097.0	82.5	18.25	—	—	2,197.75	34.4	82.8	9.34	1,340	—	—	—
	"	Final												2,776				

\* These figures are exclusive of what might have been recovered by re-threshing.

should have been, but in the oats good work was made. The quantity threshed was small compared with the other machines.

*Gibbons and Robinson's Machine.*—On the morning of June 18, the trial of this machine was commenced, some little time being expended in its adjustment. The following are the results of the three runs made on that day. During the hour's run with wheat 7,732 lb. of sheaf corn were served out, the products being 2,849·5 lb. of firsts, 75 lb. of seconds, 54·5 lb. of thirds, and recovered by re-threshing, 13¼ lb. The power taken was 11·05 h.p.

In the run with barley 6,476 lb. of sheaf corn were served out, the grain products being 3,085·5 lb. of firsts, 186·5 lb. of seconds, 74·75 lb. of thirds, and recovered from re-threshing, 32·75 lb.

Of oats the sheaf corn served out was 2,996 lb., and the products in grain were 1,135·5 lb. of firsts, 25·25 lb. of seconds, 16·5 lb. of thirds, and recovered from re-threshing, 5 lb.

A second trial with wheat was made with the following result. The weight of sheaf corn served out was 5,852 lb.; the products in grain were 2,190·25 lb. of firsts, 29·75 lb. of seconds, 21·25 lb. of thirds. The time occupied by this run was 35½ minutes, and the power taken was 10·04 h.p.

In this trial the proportion of weight of grain to weight of sheaf corn is almost identical with the first run in wheat. The feeding was very indifferent, and an allowance of 8½ minutes had to be made consequent on the machine becoming choked.

The wheat-straw and cavings were clean threshed, the chaff being remarkably free from dust and corn. Good work was made in the barley trials, and the chaff from the oats was the best the Judges had seen. The machine would have done more work had the feeder been well served.

*Foden's Machine.*—On the afternoon of the 14th inst. the trials of this machine were made. Commencing with the wheat run of an hour, the amount of sheaf corn weighed out was 8,144 lb., the resulting grain being 3,102·5 lb. of firsts, 101 lb. of seconds, 21¾ lb. of thirds, and recovered from re-threshing 19 lb., the power taken being 10·44 h.p.

The quantity of barley in sheaf served out was 5,812 lb., the resulting grain products being 2,720 lb. of firsts, 105·5 lb. of seconds, 24 lb. of thirds, and 23¼ lb. recovered from re-threshing. The power taken was 10·07 h.p.

During the half-hour's run with oats, the corn in sheaf served out was 4,626 lb., the resulting grain products being 1,712·25 lb. of firsts, 30·25 lb. of seconds, 11 lb. of thirds, and from re-threshing, 7½ lb. The power taken was 11·35 h.p.

A second trial with wheat was made, the duration of which

was 27.75 minutes. During this time, 6,387 lb. of sheaf corn was fed into the machine, the result in grain produce being 2,097 lb. of firsts, 82.5 lb. of seconds, 18.25 lb. of thirds. The power taken was 9.34 h.p. This was a most remarkable run, as no less than 230 lb. of corn per minute were fed into the machine, without the slightest sign at any time of choking, the machine running perfectly steadily.

In the previous trial the driving belt partially fouled the base of the dynamometer; this was rectified in the second trial, which to some extent accounts for the reduced power, but it is mainly accounted for by the absolute uniformity of feed.

The wheat was well threshed, but the chaff was not nearly so clear of dust and weeds as Messrs. Gibbons & Robinson's. A very good sample of the barley was produced, and good work was done in the trial with oats.

The enormous amount of grain threshed by this machine, especially in the final run with wheat, was due, in a great measure, to the extraordinary skill of both the feeder and the server. These men were perfectly trained, and not a second was lost, the feeding being as even as possible.

Note was taken in each instance of the setting of the drums of the various machines for the different kinds of corn to be passed through. The result showed that there was no uniformity of practice as to the setting: while one machine worked different kinds of corn with the same setting, other machines in some cases varied the adjustment in opposite directions. It would appear that the setting is regulated as much by the manner of feeding as by the nature of the corn. To ascertain the power taken to drive various parts of the machines, tests were made with three of them running, in the first instance, empty, then with the drum and fans only, and, lastly, with the drum alone (see columns 16, 17, and 18 of Table II.). The drum takes about one half of the whole power of the machine; in the case of Gibbons & Robinson's machine, it acquired even more. This is probably accounted for by the fact that, during the official run, the bearings had got hot, and, although time was given for adjusting and lubricating these before running the machine idle, it would seem that the result was not as satisfactory as might have been expected. The additional power required for the other motions of this machine is low.

In Foden's machine, the steadying effect of the large fan over the drum was very noticeable.

The points awarded according to the regulations for the various trials placed Messrs. Foden's machine (No. 4152) first, and

*Sectional Elevation of Messrs. E. Foden, Sons, & Co.'s Threshing Machine (Art. 4152)*

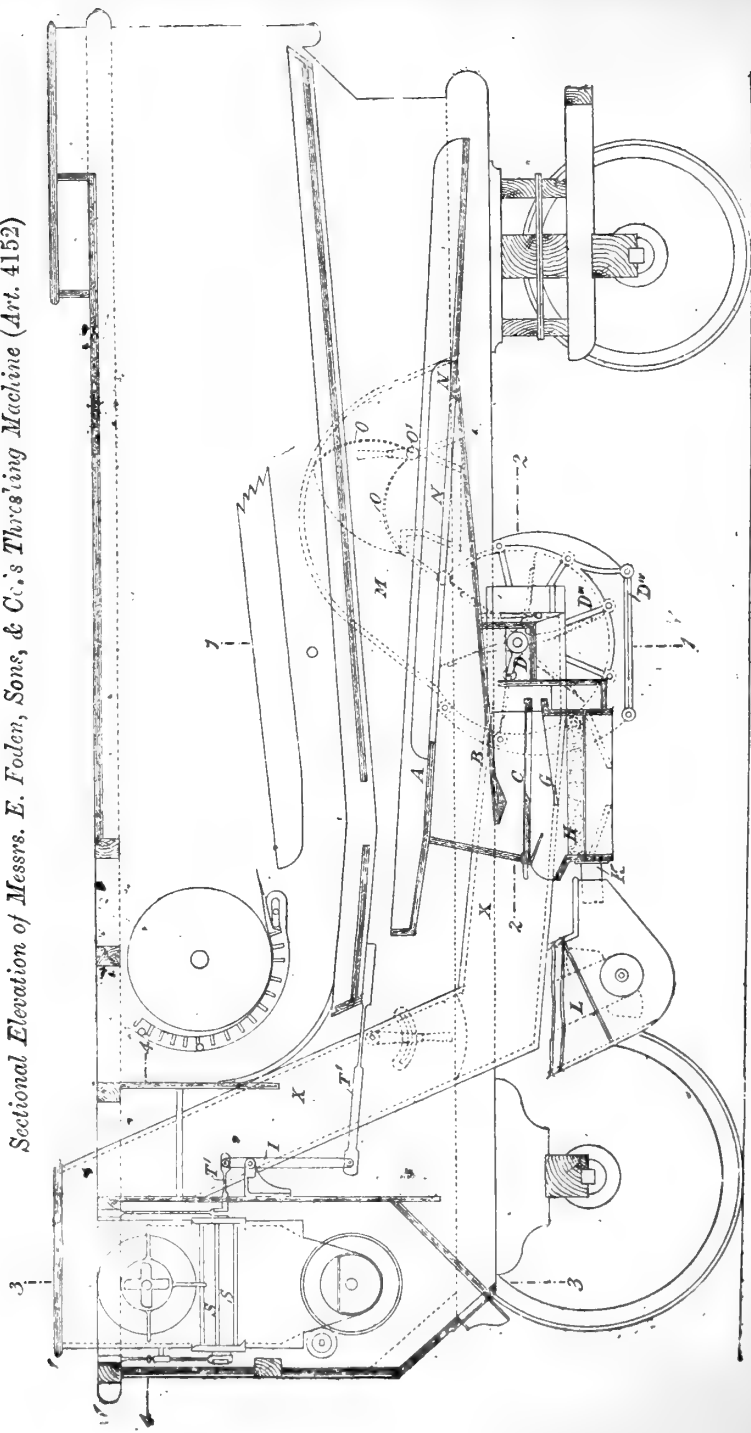

Messrs. Gibbons & Robinson's (No. 4142) and Messrs. Tasker's (No. 4144) equal second, and it was decided to class the implements in accordance with these results.

The following is a detailed description of the three prize machines.

*Foden's Machine.*—The special feature of this machine (see opposite page) consists in the employment of an exhaust fan for the first and second dressing of the grain, as also for the elevation of the chaff and its delivery into bags.

The fan (*D*) is fixed on the left side forward. The grain and other material, passing through the caving riddle (*A*), are led by a return board (*B*) to a chaff riddle (*C*), which receives a shaking movement, causing the grain to pass along the board to its edge, and to fall over it. Air is drawn through the riddle (*C*), the lighter materials being carried into the centre of the fan, and, passing through it, are delivered by the channel (*M*) into sacks or through a canvas pipe 13 in. in diameter to a convenient distance. The outer casing of the fan is perforated to allow of the escape of dust from the chaff. The grain passes through the riddle on to the return board (*G*), and from this on to the lower riddle (*H*), which stops the larger impurities and allows the grain to pass through on to a seed riddle. Here the seeds are separated, the grain passing through a spout to the elevator, which raises it to the upper part of the machine, where it is delivered by means of a worm into the awner. The awner and smutter are in one apparatus, and consist of a cylinder 13 in. in diameter by 9 in. long, roughened inside by hemispheres of about  $\frac{1}{2}$  in. diameter, 1 in. pitch. With this revolves a shaft which carries three sets of four arms of peculiar shape, which work through the grain, breaking off the awns and disengaging the smut. These arms are in halves, and can easily be replaced by others of different shape if necessary. The grain passes from the awner by a door so adjusted as to offer a suitable amount of resistance, this being regulated by a weighted lever. The grain falls over inclined louvre boards, which have a vibrating motion imparted to them from a lever and rods (*T*, *I*) in connection with the shoe. Through these louvre boards a current of air is drawn in by a special fan on the spindle of the smutter; it takes an upward direction, carrying with it the lighter corn and delivering it into a chamber, the lip of which is adjustable, so as to vary, according to circumstances, the distance through which the light corn has to be lifted. The strength of the blast from this fan can also be regulated by a shutter which can be opened or closed from the



outside of the machine. The good grain passes along the louvre boards into a passage which leads it into a rotary screen, which separates it into its various qualities, when it is delivered through shoots into the sacks. By adjusting suitable shutters the corn can be sent down to the sacks without passing through the smutter.

The machine was well framed, the bearings of the drum spindle being arranged in a casting which fits in between the verticals of the machine framing; the same casting contains the adjustments of the concave, making a very compact and strong arrangement; the main bearing pedestals are inclined at  $45^{\circ}$ .

In working, the machine was merely secured by quoins under the hind wheels, yet it was remarkably steady, and on effecting the various movements by hand it was evident that the balance throughout was very good.

Needle lubricators, neatly protected by suitable sockets provided on the pedestals, are in use on every bearing of importance.

The safety arrangement over drum aperture seems adequate. It consists of a rectangular hood, the top board of which can be advanced over the aperture as may be desired, and the feeding board is hinged so as to fold over the opening if pushed against. The whole arrangement has its sides hinged to the machine so that they can be put down flat for travelling.

*Tasker's Machine.*—The drum of this machine (see opposite page) is  $21\frac{1}{2}$  in. diameter by 4 ft. 6 in. long. The blast is worked by one fan (*F*) alone, there being three directions in which the air is delivered, as shown on accompanying diagram (*M*, *M*<sup>1</sup>, *M*<sup>2</sup>), which also clearly indicates the course taken by the grain during the process of threshing and separating.

The protection to the drum opening is good in design; a curved hood folds over the opening, by pressure either on the feeding board or applied direct to the hood. The opening, however, appears to be too large, so that with its present setting the protection will not be of much use.

The awner and smutter are in one, and consist of a conical cylinder ribbed internally, and having working inside it four arms terminating in bars of about 2 in. by  $\frac{1}{4}$  in., set a little spirally. The amount of work done can be regulated by altering the delivery opening. The screen is of the ordinary kind, except that the wires are of a V-section, the point of the V being turned inwards. In working, the hind wheels of the machine are secured by scotches, and also by a strap from the frame of the machine to the rim of the wheels. The machine is lighter than the others.

*Gibbons and Robinson's Machine.*—This machine (see p. 496)

has some special features; the whole of the reciprocating parts are driven by a single five-throw crank (*D*), which passes under the five shakers and is connected to them by brackets (*G*) two feet long,

*Sectional Elevation of Messrs. Gibbons & Robinson's Threshing Machine (Art. 4142).*

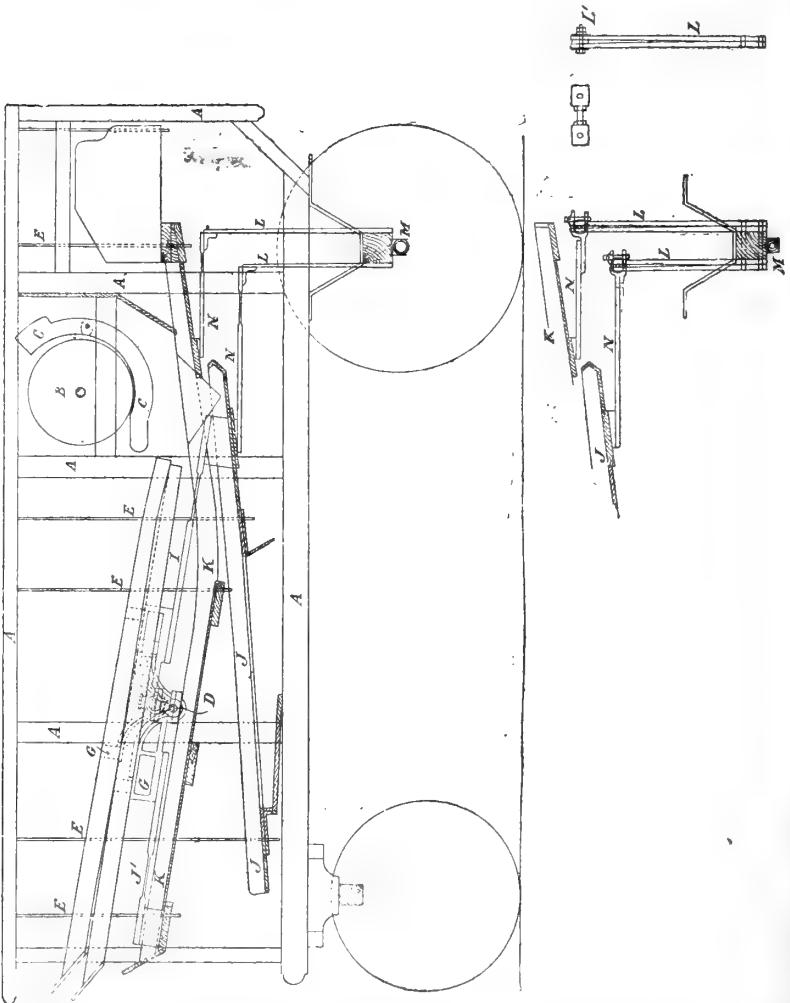

which take a firm hold of each shaker. To the same brackets are connected stiff ash connecting rods (*I*), which operate the shoes, which are supported in the usual way by vertical elastic ash ties, but have also bolted to them rigidly the rods from the



crank pedestals, so that the intermediate cranks work the upper shoe, and the three remaining, viz. the two outer and the inner, work the lower shoe, the two sets of cranks being placed opposite each other.

By this arrangement the shakers are practically supported in the vertical sense by the shoes, and therefore need not bear heavily (if at all) on the cranks; and the same connection prevents the centrifugal force due to the rotation of the crank from throwing the shakers upwards. In addition, and in order to provide a stop for the end-on momentum of the shoes, each is connected by stiff rods (*N, N*) to two pairs of vertical ash springs (*L, L*) which have their lower ends firmly bolted to the rear axle (*M*). These springs have a resisting power of about 210 lb. When at the extreme of their play, the bending of them absorbs the momentum of the shoes, and the power so stored is given out again in the return stroke. The principle is the same as that involved in the air-compressor of Willan's Single-acting High-speed Engine, or of the Worthington Compound Duplex Pump.

The arrangement in rear of the machine for the awner, second riddle, and screen is very simple and complete. The whole machine is well designed and well made, is strong, and runs very steadily.

In concluding this Report, I feel it necessary to express the obligations the Society is under to Mr. Milnthorp and his staff for their very ready and willing assistance, which materially lightened the work of the Stewards and Engineers, not a single hitch having occurred throughout the trials.

W. ANDERSON,

---

## THE TRIALS OF CREAM SEPARATORS AT DONCASTER.

THE trials under notice are undoubtedly the most important of all those with mechanical Cream Separators which, up to the present time, have been conducted in the United Kingdom. At various shows of the Royal Agricultural Society, the Bath and West of England Society, and the British Dairy Farmers' Association, separators have been brought into competition, and a prize or medal has from time to time been awarded to one or the other; but, with hardly an exception, the competition has been of a very limited nature, and in most cases the competing machines

have all been the exhibits of one firm, or at most of two. Besides this, in no instance previously have the machines been submitted to exhaustive trials; the power required to do the work has rarely been determined or taken into account, and awards have been made more as the result of general inspection than anything else. Now for the first time an attempt has been made to combine the various points at issue. For this purpose there were associated as judges, an engineer, a practical dairy-farmer, and a chemical expert. Four entire days were set apart, previous to the commencement of the Show, for the trials.

It may also be said that though, since the introduction in 1879 of cream separators into England, great improvements have been effected in individual machines, yet the prestige of winning a prize at the "Royal" was sufficient to attract the largest competition that has been brought together, and to exhibit the latest novelties, so that the trial was one comprising all the machines which are at the present time competing for popular favour.

The present would appear, accordingly, a good opportunity for reviewing the history of cream separators in England, and for noting briefly the most important modifications that have been introduced, and the principal machines that have been brought forward.

#### POWER MACHINES.

It was at the great International Show of the Royal Agricultural Society at Kilburn, in 1879, that a machine capable of separating the cream from milk by means of centrifugal force was exhibited for the first time in England. This was the "Laval" centrifugal cream separator, the invention of the Swedish chemist, Dr. de Laval. On that occasion it was awarded a silver medal, and succeeded in separating 30 gallons of milk in 52 minutes. Analyses of the skim-milk showed it to have only .22 per cent. of butter-fat left in it, and 93 per cent. of the butter-fat of the whole-milk to have been abstracted. In a second trial .46 per cent. of butter-fat was found to be left in the skim-milk, and in a third and later trial .31 per cent. Seeing that the ordinary modes of skimming milk generally leave about  $\frac{3}{4}$  per cent. of butter-fat, the advance shown was very great.

The "Laval" separator is figured and described in vol. xv. of the Second Series of this Journal (1879), p. 705, and the analytical results obtained with it by the late Dr. Voelcker are given in vol. xvi. (1880), pp. 160-2.

At the Derby Show of the Society in 1881 three different centrifugal cream separators were exhibited, viz. the "Laval;" the "Lefeldt," a German machine constructed on the same principle as the "Laval," but very cumbrous; and a Danish machine, the "Nielsen-Petersen," which was destined to be a close competitor with the "Laval." The Danish machine differed from the others in having an open instead of a closed cylinder, and also in the method of skimming; further, it could deal with a larger quantity of milk, and separated 65 gallons per hour. Full descriptions and illustrations of both the Danish machine and the "Laval" are given in vol. xvii. of the Second Series of this Journal (1881), pp. 639, 642-3.

The first competition among separators was held at the Reading Show of the Society, in 1882, when a gold medal was offered. Originally there were ten entries, but, owing to an injunction that had been obtained for infringement of patent, only four machines, the exhibits of two different makers and representing two distinct principles, actually competed. These were, the "Laval" (Swedish), and a machine by Heinr. Petersen, known as the "Hamburg Centrifugal Separator." This latter is figured and described in the Journal, vol. xviii. (1882), p. 621. The Gold Medal was awarded to the "Laval" separator, which, showing  $\frac{2}{10}$  of a horse-power, separated 53 gallons of milk in the hour, and left on an average .24 per cent. of butter-fat in the skim-milk. The Hamburg machine required  $\frac{2}{10}$  of a horse-power, and separated 80 gallons in the hour, the skim milk containing in one case .26 per cent. and in another .41 per cent. of butter-fat.

At the succeeding Shows of the Society, viz. York 1883, Shrewsbury 1884, Preston 1885, and Norwich 1886, the "Laval" (now exhibited by the Dairy Supply Company, and capable of separating 60 gallons per hour), and the Danish machine of Nielsen-Petersen, manufactured by Burmeister and Wain, and exhibited by the Aylesbury Dairy Company, held the field alone.

At the Annual Show of the British Dairy Farmers' Association in October 1884, however, these two machines had come into competition, consequent on the offering of a Gold Medal by the Association, and at the conclusion the medal was awarded to the "Laval" separator. The trial, however, was allowed not to be thoroughly satisfactory nor complete; the time given was too brief, and the power required for working was not tested. The "Laval" separator left .67 per cent. of fat in the skim-milk, the Danish machine .18 per cent. in one case and .32 per cent. in another.

At the Newcastle Show of the Royal Agricultural Society in

1887, an improved "Laval" machine was shown, known as the "Laval A1," and capable of separating 90 gallons per hour; also a "Laval" worked by a steam turbine, and called the "turbine cream separator." This latter is figured and described in the *Journal*, vol. xxiv. (1888), p. 208.

At the Nottingham Show in 1888 a new machine, the first of British construction, the "Victoria," was introduced. It was exhibited by Freeth & Pocock, and manufactured by Watson, Laidlaw & Co., Glasgow. The chief features of the "Victoria" were, that it was a self-skimming machine, emptied itself completely, and was easily cleaned. The wheels imparting the motion were arranged on the sun-and-planet type. It met with favourable notice from the Judges of Implements, and is figured in the *Journal*, vol. xxv. (1889), p. 99. At this same Show further improvements were exhibited, especially in the form of "heaters" for warming the whole-milk before going into the separator, and the skim-milk as well after separation. The "Victoria" machine was also exhibited at the Newport show of the Bath and West of England Society the same year; on trial, it left only .11 per cent. of butter-fat in the skim-milk. The Danish (Nielsen-Petersen) and "Laval A1" machines were also exhibited here.

At the Windsor Show in 1889 the "Laval A1" was again exhibited, and also a new power machine, the "Alexandra," manufactured by Koefoed & Hanberg of Copenhagen, and shown by R. A. Lister & Co., Dursley. The "Alexandra" is figured and described in the *Journal*, vol. xxv. (1889), p. 530.

In a competition for a gold and a silver medal offered by the Bath and West of England Society at Exeter in 1889, five power machines entered, comprising the "Laval A1," the "Turbine Cream Separator," the "Victoria" (two sizes), and Lister's "Alexandra." The weights of butter produced from equal quantities of cream were almost alike, and the skim-milk in each case contained but little butter-fat. The principal results obtained were:—

	"Laval A1"	"Turbine Separator" "Oscar"	"Victoria" (small)	"Victoria" (large)	"Alexandra"
Time occupied in separating 300 lb. milk . . . . .	20 mins.	18 mins.	39 mins.	20 mins.	18 mins.
Butter obtained on churning . . . . .	24 lb. 8 oz.	24 lb. 10 oz.	24 lb. 8 oz.	24 lb. 8½ oz.	23 lb. 11½ oz.
Butter-fat in skim-milk . . . . .	.15 per cent.	.10 per cent.	.16 per cent.	.08 per cent.	.17 per cent.

The Judges, while allowing that there was very little, if anything, to choose between the machines, awarded the gold medal to the "Laval A1," as showing the most important points in practical working, and gave the silver medal to Lister's "Alexandra," for ingenuity and simplicity of construction.

Lastly, at the Plymouth Show of the Royal Agricultural Society in 1890 the "Alexandra" separator was shown, with an improvement in the shape of a "heater" for the milk before passing into the separator.

HAND MACHINES.

These first made their appearance at the Newcastle Show of 1887, when a prize was offered for a one-man-power separator. For this, three machines entered, viz. a "Laval" vertical hand separator, a "Laval" horizontal machine (both the exhibits of the Dairy Supply Company), and a "Danish" (Burmeister & Wain's) hand separator (exhibited by the Aylesbury Dairy Company). The last-named was injured and did not compete, so the prize was left to the two "Lavals," of which the vertical one was adjudged the best, it separating 23½ gallons of milk in the hour, and appearing to be within the power of one man, while the horizontal machine, probably through some mal-adjustment, seemed to be beyond one man's capability. These machines were similar in principle to the power machines already described, and merely smaller in size and different in pattern. The vertical hand "Laval" is described and figured in the Journal, vol. xxiv. (1888), p. 199. The horizontal machine was subsequently improved and is now known as the "Windsor."

In the same year, at the Dorchester Show of the Bath and West of England Society, the same three machines appeared. Once more something went amiss with the Danish separator, and, though in the trial there was little to choose between the two "Lavals," the Judges gave the gold medal to the vertical machine as being simpler and more easily cleaned than the horizontal. Both machines are figured and described in the Journal of the Bath and West of England Society, vol. xix. (1887-8), pp. 6-8. The chief results were:—

	Vertical "Laval"	Horizontal "Laval"
Gallons of milk separated per hour . . . . .	25 gallons	35 gallons
Butter-fat in skim-milk . . . . .	14 per cent.	17 per cent.

At the Nottingham Show in 1888 there was no competition for hand separators, but the Judges of Implements reported a decided advance to have been made in the machines sent for exhibition, they now being well within the power of a lad.

Two machines, viz. the Danish (Burmeister & Wain's) hand separator, and a yet smaller size of the vertical "Laval" hand machine than had been shown before, and called the "Baby," were on view. They are both figured and described in this Journal, vol. xxv. (1889), pp. 98-9. The Danish machine separated 15 gallons of milk per hour, and the "Baby" 12 gallons.

Two fresh machines were exhibited at the Jubilee Show at Windsor in 1889, these being the "Star" hand separator (exhibited by the Aylesbury Dairy Co.) and the "Victoria" hand separator of Freeth and Pocock. These are figured and described in the Journal, vol. xxv. (1889), pp. 526-9. In the former the novelty was, that the driving gear was fixed to the top part of the frame of the machine. A sufficient trial could not be given to it at Windsor, and it was recommended for re-exhibition at Plymouth, though it did not, however, appear there. In a trial made at Windsor the "Star" machine left .15 per cent. of butter-fat in the skim-milk, and the "Victoria" .17 per cent.

Lastly, at the Plymouth Meeting, in 1890, the Danish hand separator, now capable of separating 35 gallons per hour, was shown, and was provided with a cream regulator. At the Bath and West of England Society's Show at Rochester, the same year the "Alexandra" hand separator of Lister & Co. was first shown.

This account brings us down to the present year, when the following prizes were announced for competition at the Doncaster Show of 1891:—

- CLASS II. Cream Separator (power machine). First prize, 30*l.* Second prize, 20*l.*  
 CLASS III. Cream Separator (hand machine). First prize, 20*l.* Second prize, 10*l.*

The entries received for the respective classes were:—

CLASS II.—*Cream Separators. (Power Machines).*

No. in  
Catalogue

- 957 Freeth & Pocock, Wandsworth Road, London, S.W. The "Victoria," price 40*l.* Skim Milk Elevator attached, 5*l.* extra.  
 1032 R. A. Lister & Co., Dursley, Glos. The "Alexandra," No. 2, price 49*l.*

No in  
Catalogue

- 1234 Dairy Supply Co., Museum Street, W.C. The "Reading Royal," price 45*l.*  
1235 Dairy Supply Co., Museum Street, W.C. The "Leviathan," price 62*l.*  
4293 H. C. Petersen & Co., Copenhagen. Burmeister & Wain's, Size B, price 43*l.* 5*s.*

CLASS III.—*Cream Separators. (Hand Machines).*

- 958 Freeth & Pocock, Wandsworth Road, S.W. The "Victoria," price 13*l.* 10*s.*  
1333 R. A. Lister & Co., Dursley, Glos. The "Alexandra," No. 7, price 21*l.* 12*s.* 6*d.*  
1236 Dairy Supply Co., Museum Street, W.C. The "Baby," price 12*l.* 10*s.*  
1237 Dairy Supply Co., Museum Street, W.C. The "Windsor," price 24*l.*  
1238 Dairy Supply Co., Museum Street, W.C. The "Alpha Baby," price 16*l.* 10*s.*  
1239 Dairy Supply Co., Museum Street, W.C. The "Alpha Windsor," price 28*l.*  
4294 H. C. Petersen & Co., Copenhagen. Burmeister & Wain's, Size X, No. 1, price 23*l.* 5*s.*

The names of the Judges were:—

R. NEVILLE GRENVILLE, Butleigh Court, Glastonbury, Somerset.  
THOMAS RIGBY, Sutton Weaver, viâ Warrington.  
J. AUGUSTUS VOELCKER, 12 Hanover Square, W.

All the entries duly made their appearance and were submitted to trial. It will be observed that in each class four different makers and four distinct types of machine were represented. These comprised really all which had been successfully introduced previously, and also four new implements, one being the "Leviathan," a power machine shown by the Dairy Supply Co.; two hand machines of the same company, viz. the "Alpha Baby" and the "Alpha Windsor;" and lastly the "Alexandra" hand separator of Lister & Co.—which was new to these Shows, though it had been exhibited at the Bath and West of England Society's Show at Rochester in 1890. The "Victoria," "Alexandra," and "Danish" (Burmeister & Wain's), among the power, and the "Victoria," "Alexandra," "Baby," "Windsor," and "Danish" (Burmeister & Wain's) among the hand machines, were much as they have been described and figured in the foregoing references, and the "Reading Royal" (power) is the improved "Laval," now capable of separating 150 gallons per hour. The real novelty consisted in the addition to the "Laval" power machine and to the two "Laval" hand machines, viz. the "Baby" (vertical) and "Windsor" (horizontal), of an arrangement of discs, fitted into the drum of the

separator, the machines being now called respectively, the "Leviathan," the "Alpha Baby," and the "Alpha Windsor."

A series of separate thin sheet-steel discs placed one above another are interposed in the drum, being loosely arranged around the spindle on which they are, so to say, threaded, and are kept about  $\frac{1}{16}$  of an inch apart from each other by means of projections stamped on them. In the "Alpha Baby" machine there are twenty-six discs, each measuring  $2\frac{1}{2}$  inches across the top opening, and 4 inches across the bottom; the "Alpha Windsor" has twenty-seven similar discs, but in the "Leviathan" there are fifty-six, and of larger size, these measuring  $2\frac{5}{8}$  inches across the top opening and 9 inches across the bottom.



A single disc, as used in the "Alpha" machines and in the "Leviathan."

A sketch of a single disc is here given. By the interposition of the discs the milk is divided up into thin layers, and, each disc acting itself as a miniature separator, the separation is much more rapidly effected, for, as demonstrated at the trial, the result is practically to double the outturn. This was the case in all three of the machines to which the arrangement was attached.

Against this must be set the extra time and trouble required in cleaning and re-adjusting the discs after each time of working, and, of course, also the extra cost.

The trials commenced on Wednesday, June 17, and occupied this and the three following days. The points to which the attention of the Judges was specially directed were the following:—

1. Price.
2. Power taken per gallon.
3. Efficiency of separation.
4. Means of regulating thickness of cream.
5. Facility for dismantling and cleaning.
6. Mechanical construction.
7. Freedom from froth, both of skim-milk and cream.

In Table I. (page 506) are given the respective prices, power employed, number of revolutions, &c.; while in Table II. (page 507) the particulars of the separation and its efficiency are stated.

The machines were all driven for testing by means of an electric motor, actuated by a dynamo driven by a balanced engine as ordinarily made by the Society's Engineers, the power being ascertained by the quantity of current used. This was read off by Mr. Prentice, one of the engineering assistants, by means of delicate instruments. So delicate was this test that, upon one of the exhibitors applying a pocket revolution indi-



cator to the countershaft of his machine, the extra power taken by this small instrument was clearly shown. There has always been some difficulty in getting a good record of small powers by existing dynamometers, and this plan seems to be a good solution of the difficulties hitherto experienced. It was tried by the Society for the first time on this occasion, at the suggestion of Mr. Neville Grenville, and although some exhibitors made an objection to it, through a technicality in the application not quite agreeing with the printed conditions of the trial, yet in the end it proved most satisfactory, and far superior to the old hand dynamometer. The latter was also used for the satisfaction of any objectors to the new system.

It remains to compare the results and to mention other points which influenced the Judges in determining the destination of the awards in either class.

## CLASS II. POWER MACHINES.

A measured run of from twenty to thirty minutes was given to each machine on June 18, the separated products being weighed and the skim-milk analysed. In other trials given subsequently the power and other factors were determined. For convenience of comparison the results of separation are stated for the hour and in percentages, the temperatures in degrees Fahrenheit. The loss includes what was left in the drum and bowl of the machine, and thus in giving the amount per hour this has been multiplied, for there would in reality not be more than one and the same quantity at the end of the hour than after a lesser period.

No. 957, *The "Victoria,"* price 40*l.*—This machine separated in the hour about 90 gallons, the smallest quantity of the five competing machines. The power required was 1·91 h.p., which was fair, but the efficiency of this machine was not so high as that of any of the others. The number of revolutions was 7,500 per minute, and the temperature of separation from 92° to 96° Fahr. The separation, however, was, along with that of the "Reading Royal" machine, the most perfect, 97·2 per cent. of the butter-fat of the whole-milk being removed, and only 0·11 per cent. of the fat being left in the skim-milk. The loss also was very small, the bowl, as explained before, emptying itself completely. In power of regulating the thickness of cream, all the machines, with the exception of the Danish one, No. 4294, were about on a par, and effected this fairly. The Danish machine was decidedly superior in this respect. The "Victoria"

TABLE I.—THE MECHANICAL RESULTS.  
*Power Machines.*

No.	Machine	Quantity of milk separated per hour	Horse-power	Number of revolutions per minute	Temperature of separation	Price	Remarks
957	"Victoria"	lb. 900	1.910	7,500	deg. Fahr. 92°—96°	£ 40 0 0	—
1032	"Alexandra"	1,448	1.162	7,000	86°—96°	49 0 0	1st prize
1234	"Reading Royal"	1,170	2.574	7,700	88°—93°	45 0 0	2nd prize
1235	"Leviathan"	3,512	1.296	6,000	84°—98°	62 0 0	—
4293	Burmeister & Wain's	1,250	1.717	4,000	88°	43 5 0	—
<i>Hand Machines.</i>							
958	"Victoria"	186	.15	Revolutions of handle 48	96°—100°	13 10 0	—
1033	"Alexandra"	338	.17	38—42	86°—92°	21 12 6	—
1236	"Baby"	132	.05	48	88°	12 10 0	—
1237	"Windsor"	327	.23	46	88°	24 0 0	—
1238	"Alpha Baby"	300	.09	50	88°—90°	16 10 0	equal 2nd prize
1239	"Alpha Windsor"	554	.12	42—45	89°—96°	28 0 0	1st prize
4294	Burmeister & Wain's	364	.13	54	68°—72°	23 5 0	equal 2nd prize

TABLE II.—THE CHEMICAL RESULTS.  
Hand Machines.

No.	Machine	Quantities separated per hour				Percentage			Butter-fat		Tempera- ture of separa- tion	Remarks
		Milk	Cream	Skim- milk	Loss, &c.	Cream	Skim- milk	Loss, &c.	Butter- fat in whole milk	Butter- fat in skim- milk		
		lb. or lb. about gal.	lb.	lb.	lb.	percent.	percent.	percent.	percent.	percent.	deg. Fahr.	gallons per hour
958	"Victoria"	186 "	23'9	168'5	3'6	12'7	86'3	2'0	3'41	0'08	96°-100°	—
1033	"Alexandra"	338 "	68'2	268	11'8	17'2	79'3	3'5	3'41	0'05	86°-92°	55
1236	"Baby"	132 "	20	107'9	4'1	15'1	81'8	3'1	3'41	0'75	88°	15
1237	"WindSOR"	327 "	31'5	270	22'5 <sup>1</sup>	10'5	82'6	6'9 <sup>1</sup>	3'41	0'157	88°	25
1288	"Alpha Baby"	300 "	29	262'8	8'2	9'7	87'6	2'7	3'41	0'87	88°-90°	30
1239	"Alpha Windsor"	554 "	57'8	482'8	13'4	10'4	87'1	2'5	3'41	0'81	89°-96°	60
4204	Burmeister & Wain's.	364 "	71'8	277	15'2	10'7	76'1	4'2	3'41	0'89	68°-72°	32
<i>Power Machines.</i>												
967	"Victoria"	900 "	98'9	793'6	7'5	11'0	88'2	8	3'51	0'11	92°-96°	—
1082	"Alexandra"	1,448 "	107'6	1,291'8	48'6	7'5	89'2	3'3	3'92	0'143	86°-96°	200
1284	"Reading Royal"	1,170 "	117	987'1	90'0 <sup>1</sup>	10'5	81'8	7'7 <sup>1</sup>	4'11	0'129	88°-93°	150
1286	"Leviathan"	3,512 "	299'3	3,127'2	85'5	8'5	89'1	2'4	3'47	0'331	84°-98°	360
4293	Burmeister & Wain's.	1,250 "	184'7	969'4	95'9	14'8	77'5	7'7	3'39	0'311	88°	150

Leak in machine.

took twenty-one minutes to dismantle and clean, and two minutes to put together again; the bowl was rather difficult to clean well. A good deal of vibration was noticed in the running. A point in favour was the facility for elevating the

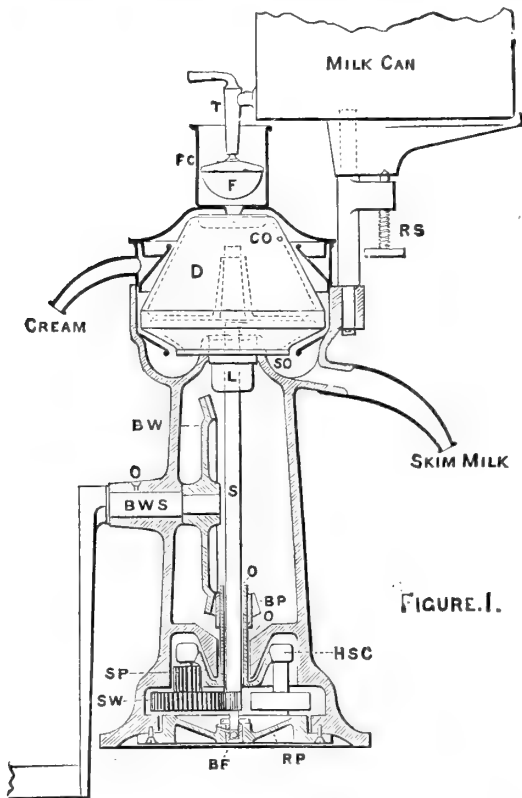

FIGURE I.

FIG. 1.—Section of the "Victoria" Power Separator.

skim-milk after passing from the separator, this being a matter of importance in large dairies. On the other hand this was the only machine to produce any excessive frothiness of cream and skim-milk.

No. 1032, *The "Alexandra,"* No. 2, price 49*l.*—This machine separated about 144½ gallons of milk per hour, though stated to be able to deal with 200 gallons hourly. The power required was 1·162 h.p., and in this respect it came out best of all, and only inferior to the "Leviathan" in the matter of efficiency. The revolutions were 7,000 per minute, and temperature of

separation 86° to 96° Fahr. The separation was good, it standing next to the "Reading Royal" and "Victoria": 96.7 per

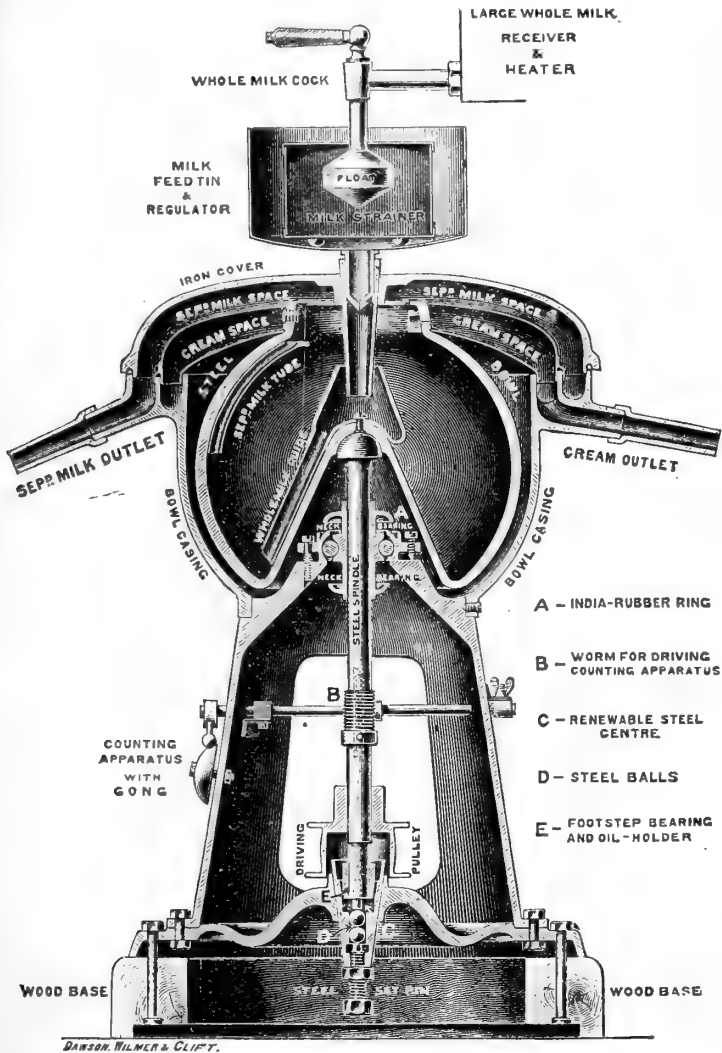

FIG. 2.—Section of "Alexandra" Power Separator.

cent. of the butter-fat in the whole-milk was removed, and 0.143 per cent. of fat left in the skim-milk. The loss was not

large. Dismantling and cleaning (which by the way was very thoroughly done) took twenty-six minutes, and two-and-a-quarter minutes to set up again. This is a similar machine to that described in the Report on the Implements at Windsor (vol. xxv. Second Series, p. 530), but with some improvements in minor details. It did its work well, is simple in construction, easy to clean, and has one most noticeable feature which no other separator had, in that it has not to be bolted down or fixed in any way. Consequently, even when running at full speed, if the belt (a thin cotton one) wants tightening, it is only necessary to pull the machine and the belt is at once put to the right tension. When finished with, it can be rolled away like a milk churn, and no special foundations are wanted. These are matters of importance in many situations, and show also how perfectly well balanced the parts must be, a most essential point in high-speed machinery. A separate contrivance, in the form of a very simple centrifugal pump attached to the machine, enables the skim-milk to be elevated after separation. Further reference is made to this machine in the report upon Miscellaneous Implements (see p. 537).

To this separator the First Prize in this class was awarded.

No. 1234, *The "Reading Royal,"* price 45*l.*—This machine separated 117 gallons of milk per hour, the stated capability being 150 gallons. The power required was 2·574 h.p., which gave the worst result in this respect, and also only showed a higher efficiency than the "Victoria." The number of revolutions was 7,700 per minute, and temperature of separation 88° to 93° Fahr. Separation was very efficiently performed, the best result being obtained—viz. 97·4 per cent. of the butter-fat in the whole-milk removed, and only 0·129 per cent. of fat left in the skim-milk. The loss was large, but was due partly to a leak in the machine during its first trial run. It took fourteen minutes to dismantle and clean, and one-and-a-half minute to put together, this being a good result, though the cleaning, &c., were not so thoroughly nor so easily done as with the "Alexandra."

To this machine the Second Prize was awarded in this class.

No. 1235, *The "Leviathan,"* price 62*l.*—This is the "Laval" power machine fitted with the steel discs referred to on p. 504. It separated the enormous quantity of 351 gallons in the hour, this result being close upon the 360 gallons it was stated to deal with. In consequence of this, it necessarily requires constant feeding and attention. The power used was 1·296 h.p., a result next best to the "Alexandra," and the efficiency of this machine was the highest of any. The revolutions were 6,000 per

minute, the temperature of separation 84° to 98° Fahr. The separation, however, was not efficiently performed in comparison with the others, for only 91½ per cent. of the butter-fat in the whole-milk was removed, and as much as 0·331 per cent. of fat left in the skim-milk. This was the worst result obtained, and

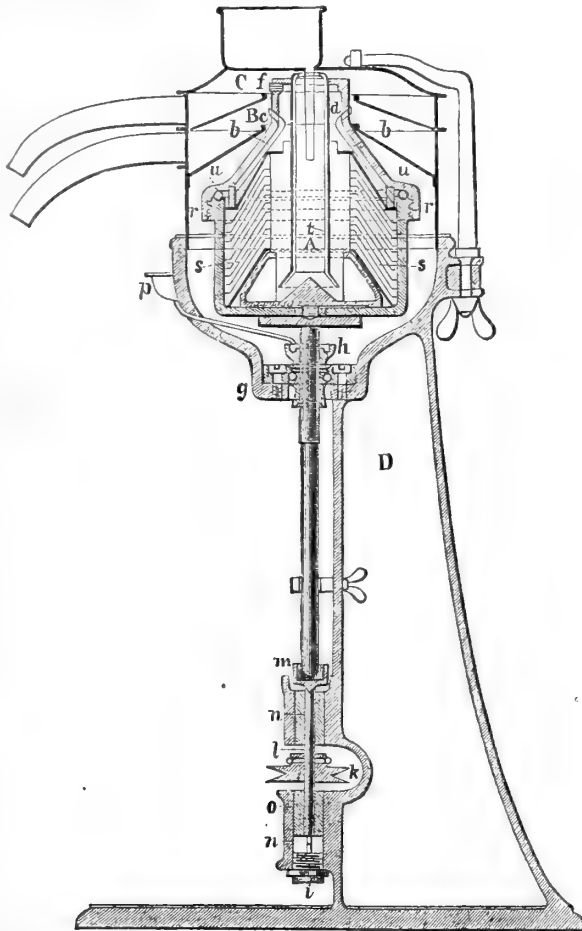

FIG. 3.—Section of "Leviathan" Power Separator.

undue haste to get through the large amount the machine was stated to deal with may have had to do with the imperfect separation. The loss for such a machine was little. Dismantling and cleaning occupied thirty-five minutes, and putting together four minutes more. It could not be said to be easy to

clean, but the rapidity with which this separator got through its work was wonderful. It is an excellent machine, and well fitted for dairy factories of the largest kind, while the application of the discs is a clever invention and in many cases well worth the extra cleaning and care required in their use.

No. 4293, "*Burmeister and Wain's*" (Danish), size B, 43l. 5s. ---125 gallons of milk were separated in the hour, 150 gallons being the quantity stated. The power employed was 1·717 h.p., this being fair, but in efficiency the machine came out inferior to the "*Leviathan*" and the "*Alexandra*." The number of revolutions was 4,000 per minute, and the temperature of separation 88° Fahr. The separation was only better than in the case of the "*Leviathan*," and inferior to the other three machines, 92·9 per cent. of the butter-fat of the whole-milk being removed, and 0·311 per cent. of fat being left in the skim-milk. The loss in working was large, the drum holding so much. This was the only machine that could really be easily regulated to produce thick or thin cream at will whilst in motion. This was done by withdrawing the cream tube so as to take only the outer wall of cream, or, by advancing it, to take a thicker shaving (to which the action may be likened) off the cream, and thus more milk with it, thereby making the resulting cream of a thinner consistency. It occupied fifteen minutes to dismantle and clean the machine, and six minutes to put it together again. This separator was a fine strong machine, and worked very well: to it was fitted "*Jönsson's Intermediate Motion*," which prevents the allowed maximum speed from being exceeded. This machine was able to elevate the skim-milk as it came from the separator.

From the foregoing remarks on the several machines it may be gathered that, in point of power required for working, the "*Alexandra*" machine was the best, and the "*Leviathan*" next best, while, in the matter of efficiency, these two machines also stood before the others. Whereas, however, the separation effected by the "*Alexandra*" and "*Reading Royal*" machines was excellent, the "*Leviathan*" and Danish machines failed very considerably. For simplicity of construction, facility of dismantling and cleaning, as also in its ready portability, the "*Alexandra*" had no equal, and, in the end, this machine stood, in the Judges' opinion, well ahead of its rivals.

Between the other machines there was but little to choose, and better separation on the part of either the "*Leviathan*" or the Danish machine might have put one of them in the position taken by the second-prize winner, the "*Reading Royal*," which,



though inferior to them in respect of power required and efficiency, effected much better separation, and, besides separating a quantity sufficient for all but exceptional circumstances, was easier of dismantling and cleaning than the "Leviathan." The latter was essentially a machine for a large factory, but otherwise it was felt by the Judges that its extra cost, and the need of extra attention, care and time in cleaning, &c., would not be warranted. The Danish machine was an excellent one in construction, and separated a large quantity of milk, but the separation was inefficient, though the regulation of thickness of cream was best done by this separator. The "Victoria" gave separation of high quality, but dealt with the smallest amount of milk, and was the only one to produce excessive frothiness of cream.

Accordingly the Judges' award was:—

FIRST PRIZE of 30*l.* to R. A. LISTER & Co., Dursley, for No. 1032, The "Alexandra" No. 2; price 49*l.*

SECOND PRIZE of 20*l.* to the DAIRY SUPPLY Co. for No. 1234, The "Reading Royal," price 45*l.*

### CLASS III. HAND MACHINES.

These were tried very exhaustively, measured runs of from twenty minutes to half-an-hour being given to the machines on each of the three days, June 17, 19, 20. The amount of milk separated was the average of three runs, and at one of them samples of the skim-milk were taken for analysis. The quantities of milk dealt with being smaller than with the power-machines, one and the same lot of milk could be used for all, and was, after thorough mixing in a tank, given out to each machine alike. The results are stated in the same terms as in the case of the power machines—viz. the separated products in pounds per hour and in percentages, the temperatures in degrees Fahrenheit. The loss includes what was left in the drum or bowl, and appears more when multiplied for the hour's run than would be the case in reality, as there would be only the same amount at the end of the hour as after a much shorter time.

No. 958, *The "Victoria,"* price 13*l.* 10*s.*—18½ gallons of milk were separated in the hour, with a horse-power of .15, which was very fair, though, as with the power machine, when the efficiency was considered, the result came out badly, and inferior to all except the "Baby." Two-and-a-half minutes were taken in getting up speed, the skim-milk came three-quarters of a minute later, and the cream in one-and-a-half minutes. The number of revolutions of the handle was 48,

the temperature of separation  $96^{\circ}$  to  $100^{\circ}$  Fahr. As regards separation, this machine showed the best result, and that an extraordinarily good one, for no less than 98.3 per cent. of the butter-fat in the whole-milk were removed, and the very low percentage of .068 left in the skim-milk. This is the best result obtained up to now in trials. The loss was low, the machine nearly emptying itself. The thickness of cream could be regulated well, though not so well as with the Danish machine. On the other hand the cream and skim-milk were decidedly frothy, a point not noticeable in the case of any of the other machines. Dismantling and cleaning occupied twelve minutes, and setting up again half a minute, the machine being fairly easy to clean. The speed was got up by an ingenious train of wheels of the sun-and-planet type.

No. 1033, *The "Alexandra,"* No. 7, price 21*l.* 12*s.* 6*d.*—This machine separated  $33\frac{1}{2}$  gallons of milk in the hour, though stated to be able to do 55 gallons. The power required was .17 horse-power, making the "Alexandra," with the "Windsor" machine, the worst in this respect, and thus very different to the power machine of corresponding type. Skim-milk came in three minutes, and cream in four minutes after starting. The number of revolutions of the handle was 38 to 42, and the temperature of separation  $86^{\circ}$  to  $92^{\circ}$  Fahr. The separation was good, and though only fourth in order of merit, less than  $\frac{1}{10}$  per cent. (.095) butter-fat was left in the skim-milk, and 97.8 per cent. of the total butter-fat in the whole-milk was removed. This was the simplest machine to dismantle, clean, and set up again, the first two operations occupying 13 minutes, and the last three-quarters of a minute. The cleaning was very thoroughly done, this not being the case with all the machines. Although stated to be able to produce thin or thick cream as desired, there was some defect in the machine, as it was not able to regulate this at all.

No. 1236, *The "Baby,"* price 12*l.* 10*s.*—13 gallons per hour were separated by this machine, 15 gallons being its stated capacity. The power required was .05 horse-power, but in the matter of efficiency the result was the worst of the seven competing machines. The skim-milk came in one minute, and the cream in two minutes after starting; the number of revolutions of the handle was 48 per minute, the temperature of separation  $88^{\circ}$  Fahr. The separation was most effectual, being next best to that of the "Victoria"; 98.2 per cent. of the butter-fat was removed from the whole-milk, and the very low percentage of .075 of fat was left in the skim-milk. The power of regulating the thickness of cream was inferior, and only a slight alteration

could be effected. In dismantling and cleaning six minutes were occupied, and half a minute in putting together again. The cleaning was easily performed, though not quite so well as with the "Alexandra." The construction of the "Baby" is practically that of the improved "Laval" or "Reading Royal," only in smaller compass.

No. 1237, *The "Windsor,"* price 24*l.*—This machine is a hand "Laval" of horizontal pattern, instead of vertical as in the case of the "Baby." It separated a considerably larger quantity of milk than the latter, viz.  $32\frac{1}{2}$  gallons per hour. The price is, however, nearly double, and the machine in question required more power to work.  $\cdot 23$  horse-power was required. It took  $\frac{3}{4}$  min. after starting, for the skim-milk to come, and  $1\frac{1}{4}$  min. for the cream. The number of revolutions of the handle was 46 per minute, the temperature of separation  $88^{\circ}$  Fahr. The separation, perhaps owing in part to a leak that occurred in the machine, was not as good as that of any of the other six machines, and the loss from the same cause was much the highest. Nevertheless, though inferior to others, the separation could not be called at all bad, for 96.2 per cent of the butter-fat was removed from the whole-milk, and only  $\cdot 157$  per cent of fat left in the skim-milk. The thickness of cream could be regulated very much better in this and the other horizontal machine than in the corresponding vertical "Lavals." 12 mins. were taken in dismantling and cleaning, and  $1\frac{1}{4}$  min. in putting together again. This was not so readily effected as in the vertical separators. A feature in the construction was the employment of a handle which could swing loosely to and fro, although the machine was still separating. This ingenious contrivance is of value as eliminating a source of danger from a handle revolving at a rapid rate when the hand power is removed, as it would be at the end of separating, although the drum would continue to revolve for a considerable time longer.

No. 1238, *The "Alpha Baby,"* price 16*l.* 10*s.*—This and the next machine to be described, the "Alpha Windsor," are the foregoing ones, Nos. 1236 and 1237, with the addition of the arrangement of discs described already. The effect has been to increase the quantity of milk separated, from 13 gallons per hour in the "Baby," to 30 gallons per hour in the "Alpha Baby," and this at an increased cost of 4*l.* 10*s.* only. The power required was  $\cdot 09$  horse-power, the second best result, as was also the case with regard to efficiency. After starting, cream came in  $1\frac{1}{2}$  min. The number of revolutions of the handle was 50 per minute, the temperature of separation  $88^{\circ}$ – $90^{\circ}$  F. Separation was well performed, though four machines showed

even better results, viz. the "Victoria," "Baby," "Alpha Windsor," and Danish machines. 97.7 per cent. of the total butter-fat was removed, and only .087 per cent. of fat left in the skim-milk. The loss was slight. As with the "Baby," regulation of thickness of cream could not be well effected. Naturally, owing to the interposition of the discs, cleaning could not be so

easily done either. It occupied 11 mins. to dismantle and clean, and one minute to set up again, but the cleaning was not done well. Still, this and the cost would appear to be compensated for by the larger amount separated. The construction of this machine was decidedly good, and equal to any other. To it an equal Second Prize with the Danish hand machine was awarded.

No. 1239, "Alpha Windsor," price 28*l.*— This was the "Windsor" machine, No. 1237, fitted with the arrangement of discs for which a Silver Medal was awarded by the Judges of Miscellaneous Implements, and which is figured on page 524. Instead of 32½ gallons being separated per hour, 55 gallons could here be

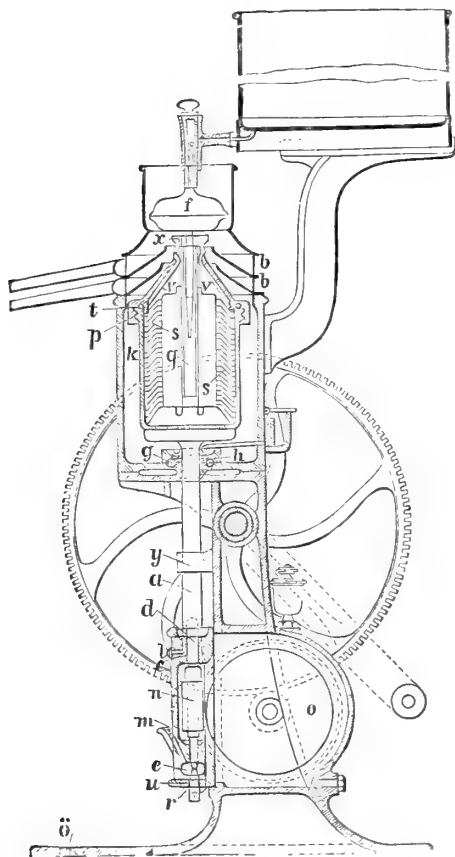

FIG. 4.—Section of "Alpha Baby" Hand Separator.

done. The expenditure of power was 0.12 horse-power, but in respect of efficiency the best result was obtained with this machine. Added to this, very effectual separation, and good construction, with large quantity of milk separated, combined to place the "Alpha Windsor" in the first position. The number of revolutions of the handle was 42 to 45, the tem-

perature of separation  $89^{\circ}$ – $96^{\circ}$  F. Only .081 per cent. of butter-fat remained in the skim-milk, 97.9 per cent. (the third best result) being removed from the whole-milk. The loss during separation was small. Regulation of thickness of cream could be well performed. Cleaning, owing to the discs, took, of course, longer than in the "Windsor." The time occupied in dismantling and cleaning was  $21\frac{1}{2}$  mins., and in setting up again  $\frac{1}{2}$  min. The construction of the machine was very good, and the loose swinging handle referred to before was attached. To this machine the First Prize was awarded.

No. 4294, "*Burmeister and Wain's*" (Danish), size X, No. 1, price 23l. 5s.—This was a strong well-made machine, with open cylinder, and the same in principle as the power machine No. 4293, already described. It separated 36 gallons of milk in the hour, and required .13 horse-power, showing a good result as to power and efficiency, though not equal to either of the two "Alpha" machines. The number of revolutions of the handle was 54, the temperature of separation much the lowest of any, viz.  $68^{\circ}$  to  $72^{\circ}$  Fahr. The separation was excellent, as, although standing only fourth in order, 97.8 per cent. of butter-fat in the whole-milk was removed, and only .099 per cent. left in the skim-milk. In power of regulating the thickness of cream the Danish hand machine was, as was the case with the power one, decidedly the best, and could produce thick and thin cream at will, without stopping the motion. The loss of milk stands rather high, owing mainly to the large amount left in the drum. Dismantling and cleaning occupied six minutes, and

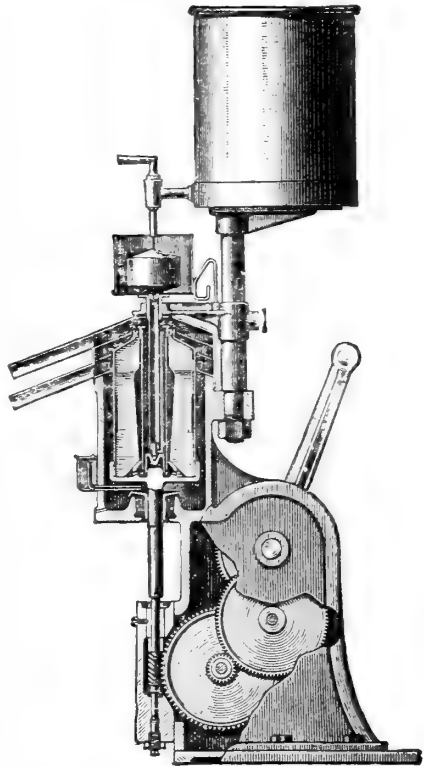

FIG. 5.—Section of Burmeister and Wain's Hand Separator

putting together again one-and-a-quarter minute. Cleaning could be very easily done.

To this machine an equal Second Prize with the "Alpha Baby" was awarded.

A perusal of the foregoing notes will readily show that, by virtue of the large quantity of milk it could deal with, the small expenditure of power and moderate cost of the latter in relation to quantity separated, as also by the efficient separation it achieved, the power of regulating thickness of cream, and general good construction, the "Alpha Windsor" obtained the highest award.

Between the merits of the "Alpha Baby" and the Danish machine the Judges could not discriminate, for, while the former gave rather a better result as regards power and efficiency, yet the separation and regulation of cream, as well as facility for cleaning, were superior in the Danish machine. The "Alexandra" failed entirely in regulating the flow of cream, and did not show the good result as to power that the "Alexandra" power machine did in the other class. It was, however, the easiest of all to clean. The "Baby" machine failed principally in the matter of efficiency, and in regulating the thickness of cream; the "Victoria," while giving the best separation, showed also high cost for the power; and lastly, the "Windsor" required rather much power, and gave less efficient separation, with more loss of milk.

The trials showed that the new improvement in the addition of the discs was very effective, and constituted a distinct advance, so that the extra care and cost would be warranted. In the "Laval" machines the horizontal type had the advantage over the vertical, of separating a larger quantity, and of regulating the thickness of cream better, while, on the whole, the power required was no more and the separation as effectual.

The Judges accordingly made their awards in this class, as follows:—

FIRST PRIZE of 30*l.* to DAIRY SUPPLY Co. for No. 1239, The "Alpha Windsor," price 28*l.*

SECOND PRIZE of 20*l.* divided between { II. C. PETERSEN & Co. for No. 4294 "Burmeister & Wain's" size X, No. 1; price 23*l.* 5*s.*  
DAIRY SUPPLY Co. for No. 1238, The "Alpha Baby," price 16*l.* 10*s.*

The Judges desire to express their obligations to the Steward of Dairying, the Hon. Cecil T. Parker, and to the Hon. Alex. Parker, Assistant-Steward, for the help they rendered during the four days of the trials, and the provision by them of all that was requisite for the proper carrying out of the same.

## NOTE ON THE EFFICIENCY OF SEPARATION.

The extent to which each machine was able to effect the removal of the cream from the skim-milk was made an important feature in these trials. Accordingly, weighed quantities of milk were given out, its quality being tested by analysis, the resulting products severally weighed, and the skim-milk subsequently analysed to see how much butter-fat was left in it. In Table II. (p. 507) are given the results obtained. One item, however, that under the heading "Loss, &c.," requires some explanation. In this is included, not only what was actually missing, *i.e.*, lost by spilling or evaporation, but also what was left in the drum or bowl of the separator. The trials varied in duration from twenty minutes to half an hour, or, in the case of the power machines, somewhat longer. Hence, in calculating the quantities per hour, the amount left in the drum has been reckoned more than once, although it is clear that had the operation gone on uninterruptedly for the full hour there would have been at the end only one and the same quantity as at the close of the shorter run. This makes the loss appear higher than it would otherwise be.

In two cases, No. 1237 (hand) and No. 1234 (power), there was at the first of the trial runs a leak in the machine, which caused an abnormally high loss to appear. This was remedied at subsequent trials.

*Hand Machines.*—For testing the efficiency of separation, one lot of milk was taken and thoroughly mixed in a large tank, quantities being weighed out from it to the different machines, according to their capacities. The whole-milk gave on analysis:—

Water	.	.	.	.	.	.	87.72
Butter-fat	.	.	.	.	.	.	3.41
Solids-not-fat	.	.	.	.	.	.	8.87
							100.00

The observations and records as to quantity separated, &c., were taken from three different trial runs on June 17, 19, and 20 respectively. The variations of temperature shown in the table are due to different temperatures being used in different trials. The results show very perfect separation indeed. With six out of the seven machines the percentage of butter-fat left in the skim-milk fell into the second place of decimals, and, as will be seen, practically 98 per cent. of the butter-fat in the milk was extracted by them. The most perfect separation was that effected by the "Victoria" machine, and the result is the best

recorded so far in an exhaustive trial. The worst result was that from the "Windsor" machine, but it is only fair to add that at the time of trial there was a leak in this machine, and this may have had to do with the separation not being so perfect. As between the six other machines there was practically little to choose. It is noticeable that the new arrangement of discs employed in the case of the "Alpha Baby" and "Alpha Windsor" machines, while nearly doubling the outturn, did not in any way reduce the efficiency of separation; also that, taking these two machines as representatives of the horizontal and vertical patterns, the separation was equally good in either case. The facility for regulating the thickness of the cream was observed in separate trials. In this respect the Danish machine, No. 4294 (Burmeister & Wain) was decidedly the best, then came the "Victoria" and the two "Windsor" machines. The two "Baby" machines were not so good, and the "Alexandra" decidedly the worst. The only machine that produced cream of excessive frothiness was the "Victoria."

It may be interesting to append, for the purpose of comparison, the results, as regards efficiency of separation, obtained at some previous trials:—

	Percentage of Butter-fat left in Skim-milk		
	R.A.S.E., Windsor, 1889	Bath and West, Dor- chester, 1887	Bath and West, New- port, 1888
	per cent.	per cent.	per cent.
"Victoria" hand machine . . . . .	·17	—	—
"Star" hand machine . . . . .	·15	—	—
"Laval" horizontal hand separator . . . . .	—	·17	—
"Laval" vertical hand separator . . . . .	—	·14	—
Shallow pan system (hand skimming) . . . . .	—	·86	·40
Cooley deep system (hand skimming) . . . . .	—	·50	—

The results now obtained, it will be observed, are very considerably superior.

*Power Machines.*—The trials took place on June 18 and June 20. Much larger quantities of milk being required, it was impossible to obtain sufficient of one quality to deal it out alike to each machine. Consequently, separate analyses were made of the whole-milk in each case, as well as of the skim-milk. The time of running was from half-an-hour to three-quarters. The loss, as in the case of the hand machines, includes what was left in the drum or bowl, though, owing to the longer time of running, the results when stated per hour are more nearly the real ones than with the hand machines. There was a leak in No.



1234, "Reading Royal" machine, on the occasion of the first trial.

The results show the separation to have been good in the case of three out of the five machines, but not so good with the remaining two. The degree of separation, however, is by no means equal to that obtained by the hand machines. The probability is that more complete separation could have been effected had not the competitors been anxious at the same time to separate the maximum quantity of milk the machines were stated to be able to do. The best machines in respect of efficient separation were the "Reading Royal" and the "Victoria," then came the "Alexandra." Both the "Leviathan" and the Danish machine (Burmeister & Wain's) were inferior. In ability to regulate the thickness of cream, the Danish machine, however, stood decidedly first, the contrivance for effecting this being very simple and eminently satisfactory. The others were much on a par. As in the hand machines, the "Victoria" was the only one to produce excessive frothiness of cream. By way of comparison with former trials the following may be noted:—

Power machines	Percentage of Butter-fat left in Skim-milk		
	R.A.S.E., Kilburn, 1879	Bath and West, Newport, 1888	Bath and West, Exeter, 1889
"Victoria" . . .	—	·11	·18
"Laval" . . .	·22	—	—
"Laval A1" . . .	—	—	·15
"Lister's" . . .	—	—	·17

The results now recorded show accordingly a small improvement in the case of the "Victoria," "Alexandra," and "Reading Royal" machines, but the other two machines have not separated nearly so efficiently.

J. AUGUSTUS VOELCKER.

## MISCELLANEOUS IMPLEMENTS EXHIBITED AT DONCASTER.

OUT of ninety-five Miscellaneous Implements entered at Doncaster for the Society's Silver Medals, under the designation of "New Implements for Agricultural and Estate purposes," all but three were shown. A very considerable number of these implements exhibited improvements of practical value, and there

was evidence of a marked effort in most instances to simplify construction as well as to lighten the draught or power required to work the machines. On the recommendation of the Judges (Messrs. J. W. Kimber and W. J. Malden) four medals were awarded at the Show to machines, or to principles applicable to machines, which were considered to possess novelty and usefulness to a special extent, whilst one machine, recommended for further trial, was also awarded a Silver Medal after its merits had been subsequently tested. There were several others in the Showyard which might have been thought worthy of recognition had there been a somewhat less important award than the medal to be conferred. The medals were awarded as follows:—

No. in Catalogue.	Exhibitor.	Nature of Implement.
57.	W. & T. AVERY . . .	Improved dial indicator for cattle weighing machine.
609.	JAMES COULTAS . . .	Manure distributor.
1239.	DAIRY SUPPLY Co. . .	Appliance for increasing separation in Laval cream separator.
1325.	JOHN GRAY . . .	Mechanical milking machine.
113.	J. & H. KEYWORTH & Co. .	Harvester and rear-discharge binder, with low platform.

#### SILVER MEDALS.

*Messrs. W. & T. Avery*, Digbeth, Birmingham.—In the Dial Cattle Weighbridge (Art. 57) exhibited by this firm, it was the dial which more particularly attracted notice. Within the dial, and towards the outer rim, are three separate circular sections, each carrying figures from 0 to 9. When the weight is arrived at these sections revolve, and the figures representing the number of stones (14 lb.) are brought opposite an open slot in the face of the dial, where they remain fixed, and as the figures are 3 inches in height, the weight is boldly indicated. On the insertion of a ticket in the slot at the side of the dial case a printed impression of the weight is made, so that the actual weight is recorded in a manner beyond dispute. The weighbridge itself is specially constructed so that the working of the dial does not impair the accuracy of the machine. The steel-yard works without loose weights.

The custom of selling animals by live weight in the open market is gradually extending, but it has not made the progress that its supporters have desired, probably because the weights recorded and announced have not been considered reliable. With a dial, which can be placed in any convenient position, so as to allow those surrounding an auction ring to see the weight while the animal is still on the platform, this objection

is avoided; and it may be expected that the practice of selling store animals by live weight will receive an impetus should this machine come into general use.

Mr. James Coultas, Grantham—The Manure Distributor (Art. 609) is of decidedly novel design. Artificial manures are for the most part heavy, and many of them have great powers of absorption, and are thus frequently in a moist condition when taken to the field for distribution. When substances which possess the characteristics just mentioned are placed in a hopper or feed-box, and especially when they are subjected to the jolting which occurs when a vehicle is drawn across rough fields, they become so consolidated that they will not fall freely through small ports or openings, and are therefore difficult to distribute with the

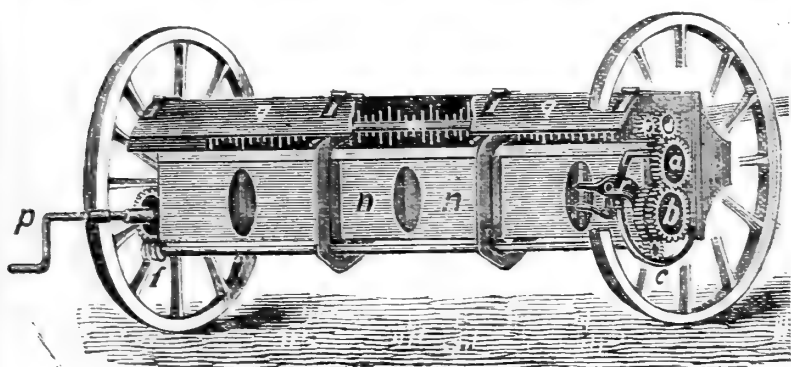

FIG. 1.—"Schlor" Patent Manure Distributor.

degree of accuracy required in the case of highly concentrated manures.

In most machines revolving spindles carrying studs, or some other form of stirrer, are used to keep up a constant flow of manure to the outlets. This they do with varying success, but if the manure is very moist or tenacious, they work it up into a paste, and make the distribution unequal and unsatisfactory. The difficulty of distributing moist manures is overcome in the "Schlor" patent distributor (fig. 1) as shown by Mr. Coultas. The feed-trough or manure box, made from 7 ft. to 10 ft. in length, is carried between two travelling wheels, and directly over the box is a revolving rake in the form of a spindle, along which a large number of prongs or spikes are placed helically. By means of gearing driven from the travelling wheels the rake is made to revolve, and at the same time the manure is gradually forced up to the top of the box, the bottom of the box being made to work

slowly and almost imperceptibly upwards, and to carry the contents of the box with it. As the manure is brought in contact with the spikes of the rake it is tumbled over the edge, and falls in a continuous stream to the ground. The rake and the box are worked in unison, and by altering the gearing the speed at which both are moved may be changed, so that any quantity between 70 lb. and 10 cwt. of a substance such as nitrate of soda may be applied per acre. The speed is determined by the pace of the horse, and as the substance does not change its density or consistency the distribution is necessarily uniform, and is practically perfect. The weight of the material does not affect the evenness of the distribution, and the machine will sow grass seeds, grain, superphosphate of lime, or nitrate of soda equally well. The parts are few, and there is little likelihood of the machine getting out of order. The price of the machine, to distribute 7 ft. wide, is 20*l.*

*The Dairy Supply Company, Limited*, Museum Street, W.C.—The special feature in this case (Art. 1239) is an arrangement of thin conical discs (fig. 2) which, when placed inside the bowl of the cream separator, greatly increases the working powers of the machine. The discs are fitted to the various forms of the Laval Separator, and are attached to the spindle of the drum.

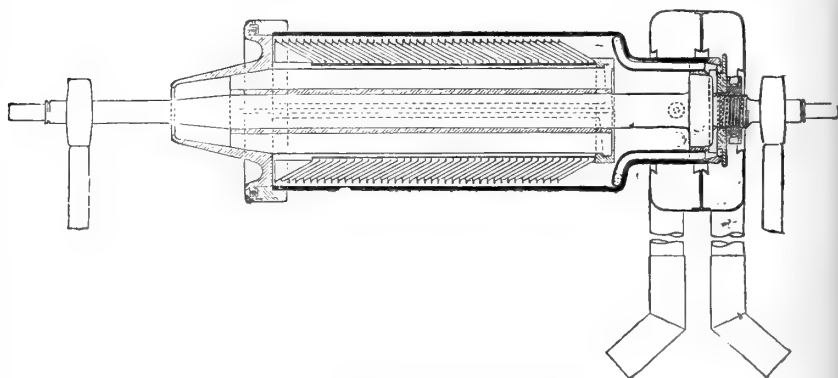

FIG. 2.—Arrangement of Discs in Separator.

They are made of steel, and, except that the base is cut out to allow the spindle to pass through them, they resemble the common patty-pan in shape. A number of discs are threaded on the spindle, but, by means of grooves in each disc, they are prevented from coming closely together, a space of one-sixteenth of an inch being left between each pair. The spindle is passed through the bowl, and is secured by means of a screw. The

effect of the discs is to laminate the milk, and thus render it more easily acted upon by the centrifugal force than when it is in a dense unbroken column. The power required to work the discs is exceedingly small, and though the arrangement adds an additional part to be cleaned, there is nothing intricate about it. An attendant possessing ordinary intelligence can at once understand the construction, and, with a reasonable amount of care, need find little difficulty in washing and adjusting it. The extra trouble is but a slight drawback in comparison with the great advantage obtained by the use of the discs, for they double the working capacity of the bowl into which they are inserted, and may, therefore, be regarded as one of the greatest improvements ever applied to cream separators. They may be fitted to machines of any size. The cost of each disc is one shilling.

*Mr. John Gray*, Stranraer, Wigtown, N.B.—Nicholson and Gray's new patent Milking and Self-Registering Machine (Art. 1325) was subjected to several trials in the Showyard, as it was entered for competition in Class 4, for Mechanical Milking Machines. The work done was of such a satisfactory nature that the Judges in Class 4 called special attention to it, and although it was not entered as a new machine, there were novelties in its design of sufficient value to render it worthy of the special Showyard recognition of the Silver Medal. As a further trial of this machine, under conditions more satisfactory than were possible in a hot and crowded Showyard, has been ordered by the Council, it is only necessary here to notice the chief novelties in its design.

The cups do not embrace the teats of the cow closely, but are held to the udder by suction, the cow's teats being suspended within them. The non-injurious character of the action which takes place is shown by the natural condition in which the teats are left after milking. Machines previously exhibited caused the blood to be drawn down to the teat in such a manner that the teat was left in a congested state, showing that an unnatural pressure had been applied. This was further proved by the fact that the milking properties of the animals were so seriously impaired, that in course of time they ceased to have any value as dairy cows.

*Messrs. J. & H. Keyworth & Co.*, 35 Tarleton Street, Liverpool, exhibited the "Adriance" Harvester and Rear Discharge Binder, manufactured by Messrs. Adriance Platt & Co., of New York, U.S.A. The machine differs from most binders in use in that it possesses but one canvas apron, the two vertical and the buttor canvases being dispensed with, and their places taken by revolving sprockets to gather the grain,

with a revolving disc to shape the butts of the sheaf. The delivery of the sheaf is effected by means of a discharger-fork, which carries the sheaf to the back of the machine and deposits it on its butt out of the track of the horses. The manner in which the work is effected may be gathered from the accompanying illustrations. The grain when cut is received by the platform apron, and carried by it to a series of revolving sprockets and a revolving buttor disc placed in the rear of the inner divider. These carry the grain upwards through a throat-way on to curved ways or feeder-scrolls, which serve to support it, and also to keep the sprockets clean and to prevent any winding of the grain. Above the sprockets, the feeder-scrolls and the

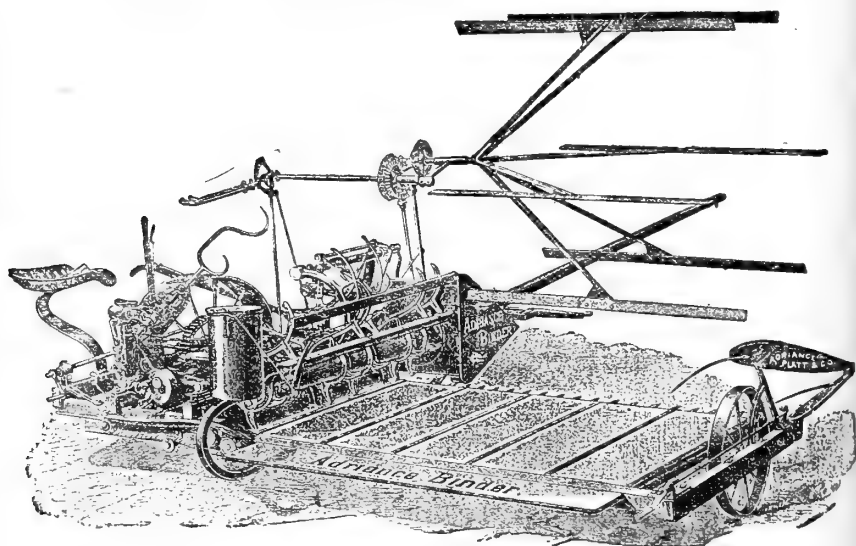

FIG. 3.—The "Adriance" Harvester and Binder.

upper compressor form the grain receptacle, in which the grain remains until sufficient for a bundle has accumulated. In fig. 3 the parts are shown in the position in which the binding mechanism is at rest, and the feeder-sprockets are operating to feed grain into the receptacle. When sufficient grain accumulates in the receptacle to raise the trip or bundle-sizer, it puts the binder mechanism in motion, and the needle which is in position above the receptacle, descends, enclosing the grain within the cord, and at the same time moves towards the binder deck, which is on the opposite side of the feeder-throat from the grain-receptacle. The needle is not forced through a mass of packed grain, but one of the sloping sprockets marked with a

star is timed to act with the needle and leave a clear way for the point (see fig. 4), and the whole needle moves away from the incoming grain, as shown in figs. 5 and 6. Fig. 5 shows the needle about half-way in its movement carrying the bundle to the binding-deck, which is close to the driving-wheel, and beginning the wide separation of the grain to be bound from

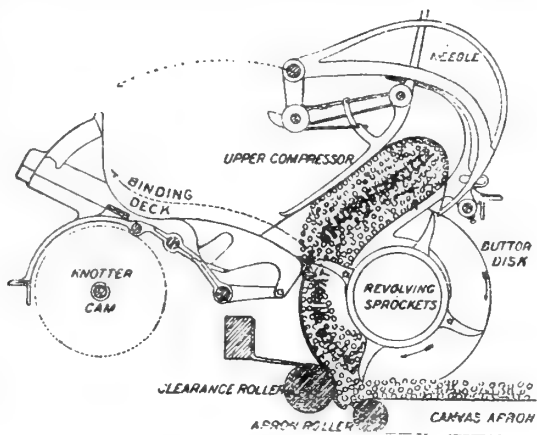

FIG. 4.—Section of the "Adriance" Binder.

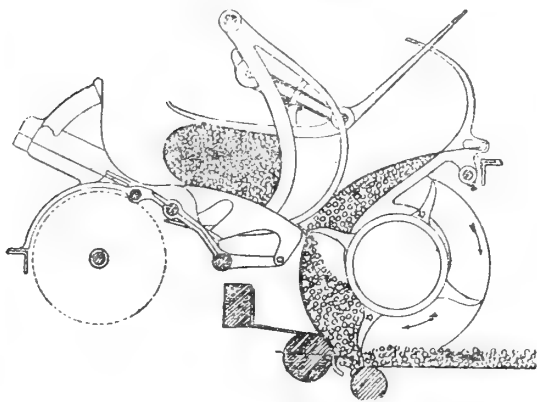

FIG. 5.—Section of the "Adriance" Binder.

that which is being fed into the receptacle. Fig. 6 shows the bundle, B, fully compressed on the binding-deck in readiness for tying. The side compressor, C, which relieves the needle from strain, is shown in this cut. The tie is effected when both the needle and discharger-fork are relieved from work and are returning to position, and while another bundle

is gathering in the receptacle. The return of the needle is not over the track of the downward movement, but over a different course, the point following the dotted line shown in

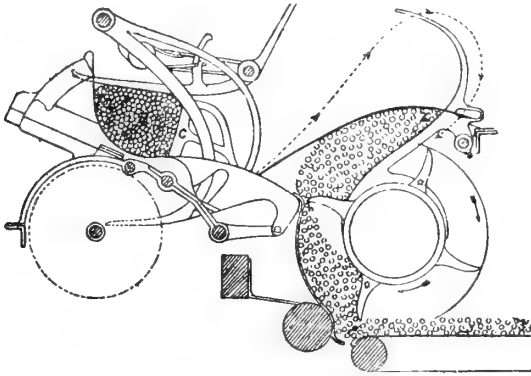

FIG. 6.—Section of the "Adriance" Binder.

figure 6 passing above the grain in the receptacle. This needle motion, in conjunction with a special rocking binder-arm, is an important feature in the separation. Every motion of the

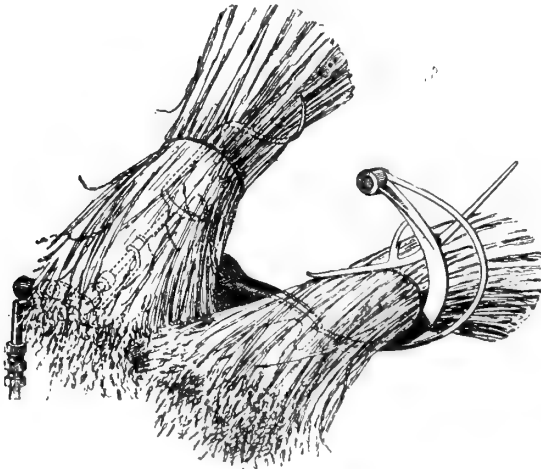

FIG. 7.—Discharger-fork of the "Adriance" Binder. The dotted line shows the centre of motion in turning the bundle.

needle and swinging binder-arm is controlled by one crank, and harmony of movement consequently results. The discharger-fork, which is pivoted at the rear corner of the binder-frame, lifts the bound sheaf from the deck, and, turning it completely over



endwise (fig. 7), delivers it gently on the butts in the rear of the machine. The whole work is therefore effected without vertical aprons, and the sheaf is never raised more than about 15 inches. Vertical aprons formed the most convenient method of bringing the corn to the sheafing and tying apparatus that had suggested itself to makers of binders hitherto, but they are cumbrous, and necessitate a multiplicity of working-parts, thus adding to the intricacy of the machine, which from the variety of duties it has to perform is necessarily complex. The work of the two extra aprons has not been thoroughly successful, as they frequently cause stoppages through shrinking when they become wet; and they are liable to knock out ripe grain as it is being carried up between them.

The "Adriance Binder" was tried on Mr. Milnthorp's farm on a heavy crop of green rye and did highly satisfactory work. The draught was apparently light; and the cutting, owing to the crank wheel being placed on a near level with the knife-bar, was easy. The sheafing and tying were well done, the separation being very clean. The delivery of the sheaf was gentle and little likely to thresh out the corn had it been ripe, although a few ears were slightly turned up when the sheaf was inverted, but apparently not to a serious extent. The rather great width between the two travelling wheels might prove an objection on uneven land, but taking the appliance as a whole it showed itself to be capable of doing good work, and the machines of the future will doubtless be designed without the objectionable vertical aprons.

As the result of their examination of the "Adriance" Binder in the Showyard, the Judges recommended its being subjected to further trial later in the season, when ripe corn crops would be available.

The Council having decided that it should be put to further and more practical test, arrangements were accordingly made for the trials to take place on Mr. Milnthorp's High Ellers Farm, near Doncaster, on August 31. The machine employed was the one exhibited at the Show in June, where Mr. Milnthorp purchased it, and previously to the trial it had cut 100 acres of corn on his farm to his perfect satisfaction. It was taken direct from ordinary work into the trial field.

The first trial was on a crop of wheat which was fairly thick on the ground, stood well on three sides, and would have been easy cutting except that the soil was so very loose that the driving wheel could not obtain sufficient grip to drive the machinery in places where the crop was particularly heavy. The soil was as loose as we have ever seen it on the lightest

blowing fen-lands. As it was, the work was done very satisfactorily, the sheafing and delivery being good, and the draught extremely light.

The machine was then taken into a very heavy crop of barley, than which it would be almost impossible to find a more difficult piece of work. In many places, large patches had been laid for weeks, and were rotting, while a young crop had grown through from the roots. The ground was quite as loose as that on which the wheat was growing, and there had been a sharp shower a few hours previously, which made the straw tough, and hindered separation, rendering it liable, moreover, to be pulled up by the roots if there was the slightest block in the knives. A larger divider was used for the heavy and fallen crops of barley and rye than for wheat. Notwithstanding the difficulties which presented themselves, the work was well done. The sheaf was neatly gathered, and presented a uniform appearance all round, very few ears being doubled back. As far as could be seen, no corn was threshed out as it was being gathered or delivered.

The machine was next tried in a very heavy crop of rye, 6 feet in height, but leaning somewhat in one direction. The crop was very ripe, and had become so interwoven on account of many of the heads having doubled over that perfect separation appeared almost impossible; however, the work was well done on three sides, but on the fourth side the separation was not perfect—two, three, and occasionally more sheaves being linked together. The sheaves were practically distinct, and each was securely tied, but a few of the ears intertwined so that they were not delivered separately, although the cleverly constructed delivery fork proved itself to be a very capable instrument.

The work, viewed as a whole, was efficiently done, and clearly proved that the upright aprons are not a necessity, and that many intricate parts might be dispensed with without impairing the efficiency of the machine. The lightness of draught was very apparent, two horses working the machine with no signs of distress. The driving power appeared somewhat deficient, though this was partly due to the extreme looseness of the soil, but doubtless it would be advisable to secure more power for the heaviest English crops. The weight of the machine is about 11 cwt.

The machine gains so much on the points of simplicity and lightness of draught, that the Judges had no hesitation in recommending the award of a Silver Medal.

This completes the record of the awards of Silver Medals in connection with the Doncaster Meeting.

Mr. Augustus C. Arter, Hilly-field Works, Barham, Canterbury, entered a Potato Planter (Art. 99) which is likely to prove useful to those who plant their potatoes on the flat, as it is simple, effective, and cheap. The machine consists (fig. 8) of a hopper, one side of which is concave, and the other a revolving cone mounted on an axle; these are carried on an iron frame, to which are fitted a beam and a fore-steering. The cone, which is driven by gearing attached to the travelling wheels, has a series of projections, each of which is furnished with a needle bar. The needle bar is fitted with three points; near the middle of the needle bar are a stud and spiral spring, and at the back of the cone is a fixed cam which actuates the needles. When one of

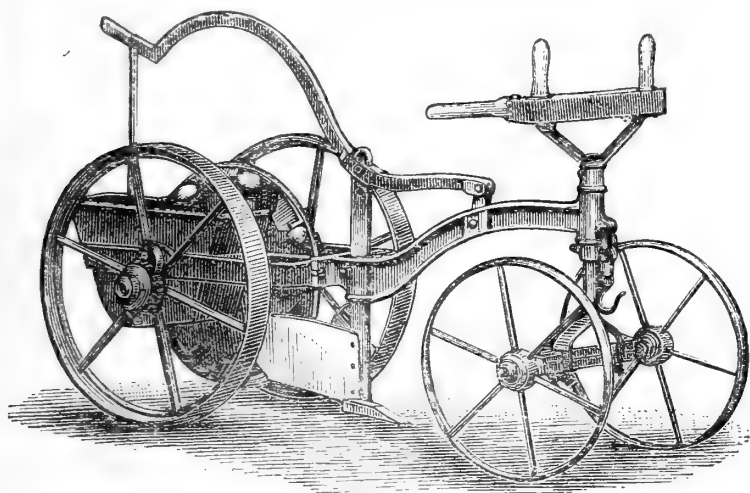

FIG. 8.—Arter's Potato Planter.

the projections enters the bulk of potatoes, the needle is held back by the cam until a potato is driven up to the projection, when it is impaled on the needle, and conveyed to the top of the cone to the spout. Here it is released by the cam, which withdraws the needle until it is flush with the cone, and the potato falls into the furrow already made by a coulter to which are attached small adjustable mould-boards, and which is fixed in front of the spout. The machine is light in draught; has few working parts which are likely to get out of order; is capable of planting from three to four acres a day, when worked by a boy to lead the horse, a man to steer the machine, and another to keep the hopper filled; and is guaranteed to deposit accurately 95 per cent. of the potatoes, though in the short trials we wit-

nessed, it did better work. The steerage is fairly good; the potatoes can be planted at various distances apart, and the tubers seemed to have suffered little by being pricked. A simple arrangement might with advantage be attached to cover in the potatoes after they are deposited in the furrow, as it would save the necessity of covering them in by other means, and extra trampling by horses would be avoided. This is an effective

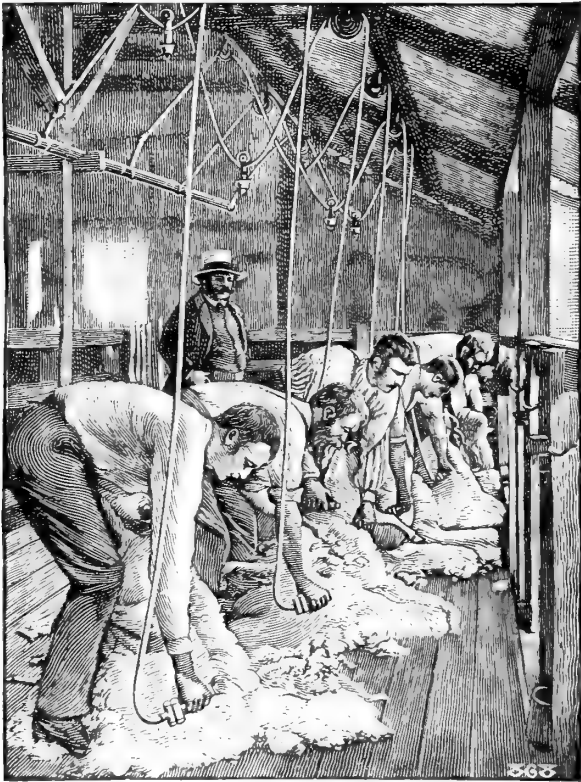

FIG. 9.—Compressed Air Sheep-Shearer.

and labour-saving machine, and in those districts where labour is scarce is likely to be found very valuable. Price 15*l*.

*The Australian Shearer Co., Limited*, 81 York Street, Sydney, N.S.W., showed their Compressed Air Sheep Shearer (Art. 3906), which is undoubtedly a clever and useful invention. The appliance is worked by compressed air, and embraces a reciprocating double-pistoned engine having a suitable air-valve

which controls its action. The piston is connected with a lever which moves the cutter, the latter being made with several teeth, as is usual in clipping machines. A small engine or other motive power is required to work the air-compressor, and to drive the air into the air-receiver. The air is then conveyed by means of tubing (fig. 9) to the shearers, several of which may be set in motion simultaneously. Shafting and belting are thus rendered unnecessary, thereby making the apparatus more portable and more easy to set up than when other kinds of shearers are employed. The shearer (figs. 10 and 11) is attached to flexible rubber tubing which permits the operator to work in any position, and a small tap near to the shearer allows him to

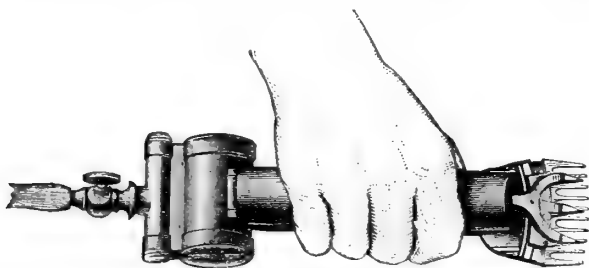

FIG. 10.—General view of Shearer.

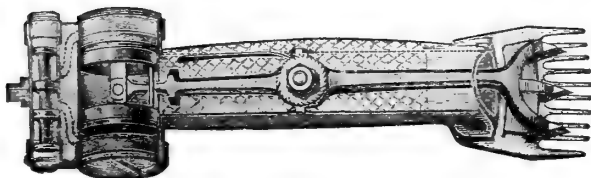

FIG. 11.—Shearer with cover removed, showing working parts.

put the machine in or out of gear at will. Although great speed is attained, the shearer does not get hot, as the exhaust air keeps all parts cool, thus materially increasing its durability.

It is essentially a machine for working on a large scale, and the number of shearers which can be worked at one time is practically unlimited, whilst one skilled man is sufficient to overlook the operations of a large gang of workers, thereby rendering it unnecessary that all the men should be skilled in the use of machinery, and making the machine more valuable, as it is sufficient that the men should be able to hold the sheep in a proper manner. The wool is cut off in an even manner all over the sheep, and the skin is neither cut nor bruised. Moreover, as the sheep is under the hands of the operator for a shorter time

than when the common hand-shears are used, it struggles less, and is not so likely to sustain internal injury. There are few flocks in England where it would be found necessary to resort to such a wholesale system, as the shepherd can generally manage to shear his sheep without causing much hindrance to his work at shearing time, which is usually light as compared with that at other seasons, for the sheep are generally ranging wide instead of being close-folded. In those districts, however, where the shearing is done by gangs of men who go round from flock to flock, the machine might be found useful. It would be difficult to conceive a machine which could be better adapted for getting through a large amount of high-class work, and where flocks are numbered by thousands, as in the Colonies and in Argentina, it

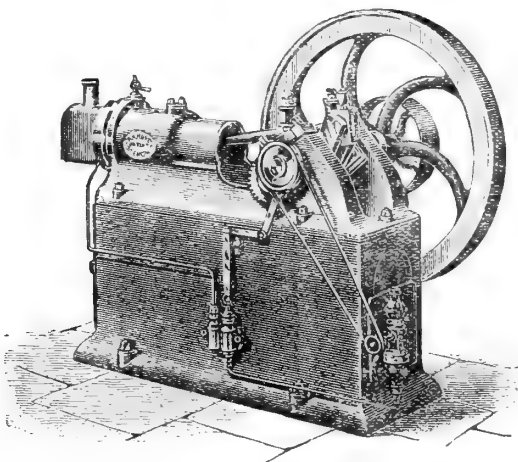

FIG. 12.—Hornsby's Petroleum Engine.

has already been found of great value, and will doubtless be more used. The price per shearer is 10*l.* for not less than twenty, including air receiver, and all apparatus except motive power and air compressor.

*Messrs. R. Hornsby and Sons, Limited*, Grantham, exhibited a Petroleum Engine (Art. 3789), the chief feature of which is its extreme simplicity, a point of no little importance in the case of small engines placed in the hands of inexperienced operatives.

The engine (fig. 12) is of the horizontal type with a trunk piston, the cylinder being  $7\frac{1}{4}$  inches in diameter by 10 inches stroke, the mean speed at which it is worked being about 220 revolutions per minute. In the Catalogue it is described as of

3 horse-power nominal, but it was explained that in future this size of engine should be registered at  $2\frac{1}{2}$  nominal horse-power.

The movements of the engine are as follows: On the crank shaft, just outside the main bearing, is a pinion which gears into a second one running at one half the number of revolutions. On the second pinion is a cam-plate which at every alternate revolution of the engine actuates a bell-crank lever, one end of which is held up to the cam face by a spiral spring; the other end of the lever works a small feed-pump, the suction-valve of which is controlled by the governor, which in rising "trips" it to a greater or less extent. A further adjustment of the stroke of the pump is effected by a regulating screw-stop acting on the bell-crank lever in opposition to the spiral spring which brings the lever in contact with the cam face.

This feed-pump takes its supply of oil from an oil chamber in the bed-plate underneath the crank shaft, and delivers it into a combustion box placed immediately behind the cylinder, and it is this combustion box which is the special feature of the engine. It consists merely of a cast-iron box communicating directly with the back end of the cylinder. At starting, this box is heated by means of an oil lamp and hand blast to the requisite temperature for ignition of the oil, and when this is done, the engine is turned round by hand for one or two revolutions, and the heat generated by the recurring explosions maintains the temperature for the continued ignition of the charges of oil pumped into it. The air is admitted through the ordinary inlet valve, and the exhaust valve is actuated by a vibrating lever, passing along underneath the bed-plate, and worked by a cam on the intermediate shaft carrying the second pinion already referred to.

A trial of the engine was made, with a heavy mineral oil of a specific gravity of 0.85, and with a reported flashing point of  $150^{\circ}$  (the oil was tested previous to trial up to  $135^{\circ}$  without flashing), with the following results:—

The mean brake horse-power = 2.9.

Total oil consumed in 2 hours = 10 lb.  $0\frac{3}{4}$  oz.

Oil per brake horse-power per hour = 1.54 lb., or 1.45 pints per brake horse-power per hour.

The cost of the oil was stated to be 5*d.* per gallon. Although the consumption of oil per brake horse-power is in excess of the result obtained in previous competitive trials at Plymouth, it must be borne in mind that the engine now under consideration was of much smaller power, and consequently so high an efficiency would not be obtainable as in the prize engine on that

occasion. Further, the engine is yet in a somewhat early stage of development, and some details will no doubt be improved upon. During the trial, however, the firing of the charge was regular, and the combustion was complete. From its extreme simplicity it should prove to be a very useful engine for farm purposes.

*Messrs. Harrisons & Co.*, St. Peter's Works, Stamford, showed their new Central-suspended Double-action Haymaker (Art. 2256). The novelty and advantages in the machine (fig. 13) are that the forks are carried on the main axle without any intermediate gearing, thus doing away with unnecessary parts, ensuring the working of the tines at a uniform distance from the ground when crossing ridge and furrow, and making it independent of the position of the horse, thus obviating the necessity for an adjustment to regulate the height of the tines, although means are pro-

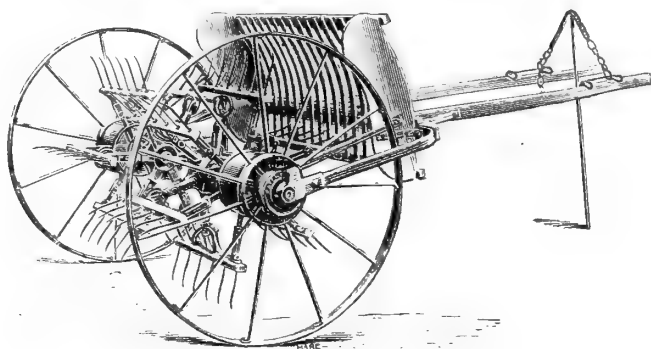

FIG. 13.—Central-suspended Double-action Haymaker.

vided for raising or lowering them if occasion demands it. The gearing consists of an internal toothed wheel mounted on a sleeve. The sleeve has a cross arm upon which are mounted two connecting pinions which are of the proper size to gear into the bedding-fork pinion, and are arranged opposite to each other, the thrust of one pinion taking up the thrust of the other pinion, thus carrying the tedding-fork pinion and greatly reducing the friction. The reversing of the action of the machine is accomplished by first holding the internal wheel or revolving the sleeve carrying connecting pinions, and then revolving the internal wheel with the road wheel and holding the connecting pinions fixed to the frame. The clutches for doing this are simple, yet also form an effective ratchet to reduce the strain on the tedding-forks when the machine is brought to a sudden standstill. The construction of the machine is very simple, one



set pin releasing the whole of the parts, there being neither keys nor feathers employed about it. The small number of parts, the directness of the action, and the general simplicity of the machine, allow it to be constructed lightly without impairing its strength, and consequently the draught is light. Its cost is 13*l.* 13*s.*

*Messrs. R. A. Lister & Co.*, Dursley, Gloucestershire, exhibited their "Alexandra" Cream Separator (Art. 1032), which was successful in gaining the first prize in the trials open to power separators. The working of the machine is described in the report of the trials (page 508), so that a brief description of the separator will suffice here. A distinctive feature is that the steel bowl is simply supported on the top of the spindle, the upper end of which is rounded, and fits into a recess in the bottom of the steel bowl. No matter in what position the bowl is placed, directly the spindle attains anything like its proper speed the bowl centres itself, and runs perfectly true, thus avoiding all strain in the neck-bearing of the spindle, and rendering it unnecessary that the frame should be placed perfectly level, as the bowl finds its own centre. The bottom of the driving-spindle runs in a foot-step in which are two ball-bearings, so that the friction is small, and the lubrication is rendered easy and effective.

The neck-bushing is oiled in an ingenious and simple manner. The oil is conducted to the bottom of the bushing with a small dish which is formed within it. It is next carried upwards by a spiral groove cut in the bushing, and then overflows, and is carried away in a dish formed on the top of the bushing, and is led into an oil drip tin, so that the oil is continually making a circuit of the bearing. The steel drum is made of one solid piece of wrought steel, and the steel is equal to a tensile strain of sixty tons to the square inch. The machine is driven by a light endless cotton band one inch wide, no belt-tightener being required, as the machine can be easily shifted, and owing to its construction it can be placed unfixed on any floor, without fear of its shifting its position unless it is desired.

*Messrs. Blackstone & Co., Limited*, Rutland Engineering Works, Stamford, have, in the construction of their Rutland Mower (Art. 2901), adopted principles which enable the machine to cut out the grass from the bottoms of furrows. The entire body of the machine containing the gearing is hung on bearings, or brackets, or arms, fixed to the main axle, and the hinge-beam, being as usual hinged to the body, the finger-beam is practically on a universal joint, the move-

ments of which are controlled entirely by the leading wheel. The finger-bar cannot be floated over a hollow, for it is quite independent of the movements of the pole; neither can it drop perpendicularly into it, as the leading wheel by which it is entirely controlled will raise or depress the finger-points as occasion may require, and so cause the fingers to follow the formation of the ground over which they are passing. The finger-bar of an ordinary mower is held rigidly in one position by the tipping lever, and, in coming to a hollow place, will be either floated over it altogether or will drop perpendicularly into it.

The same makers have introduced an improvement (Arts. 2902-5) in the construction of turnip-cutter knives, which is worthy of notice. The knives—Tipton's patent—are made with an acute angle, so that when the barrel revolves they strike the roots with a point instead of with a broad edge, thus pinning the roots, and preventing them from jumping about in the hopper, thereby rendering the work more easy and more expeditious.

*Mr. Robert Maynard*, Whittlesford Works, near Cambridge, showed a useful novelty in his Chaff Presser and Bagger, which is worked in connection with the chaff-cutter (Art. 4309). After the chaff is sifted it is taken up an elevator (fig. 14) and poured down two cylinders into the sacks. The elevator is made sufficiently high to carry the chaff to the top of the tubes, in each of which is a screw. The bags are slipped on to the bottoms of the tubes, and the chaff as it falls into the tubes is passed through the screws into the bags. As there is resistance given by weights and breaks to a frame which presses on the bottoms of the bags, the chaff is screwed into the bags, which sink with the frame as the chaff presses them down. When working, one bag is being filled whilst the other is being taken off, and another empty bag hung in its place. As soon as the one bag is filled, the chaff is turned into the other by means of a flap which is worked by a lever handle. As the chaff is compressed into half the space it would ordinarily occupy, the advantage is easily seen; for it becomes more portable, and the cost of transit is reduced, whether by rail for great distances, or in carts from one portion of a large farm to another. The merits of the hay and straw pressers are thoroughly realised, and those who have large quantities of chaff to move will doubtless avail themselves of a contrivance which stands in the same relation to chaff as the former do to hay and straw.

*Mr. Walter A. Wood*, 36 Worship Street, E.C., exhibited a Single-apron Binder wherein many cumbersome and unnecessary parts usually found in machines of older make have been dis-

pensed with, resulting in a lower machine, of lighter make, and of more simple construction. Three aprons have been shown to be unnecessary, and Mr. Wood has contrived to do the work with one long apron. The machine is not such a striking novelty as the "Adriance" (page 525), since vertical aprons are not dispensed with, and the appearance of the machine is somewhat similar at first sight to the machines in common use. The platform apron is lengthened, so that it takes the place of the lower vertical apron also, and the corn is carried up by this to the

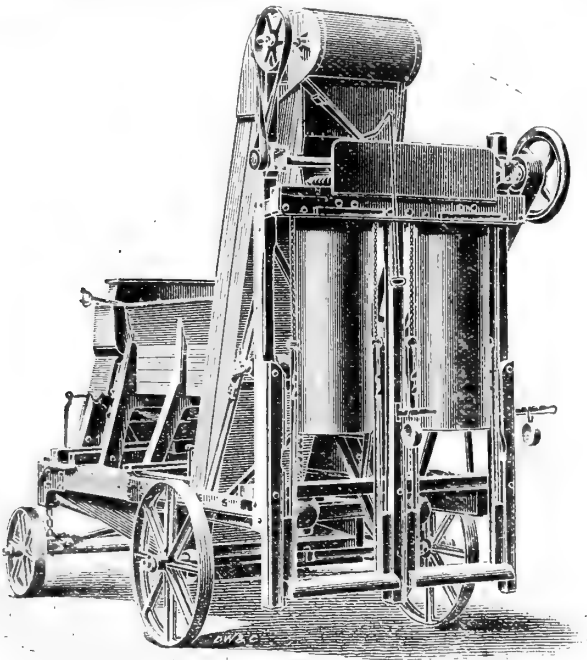

FIG. 14.—Maynard's Chaff Presser and Bagger.

sheafing platform, being kept in its place by means of an adjustable hinged rack, under which the corn runs in a continuous stream; the rack being a substitute for the upper vertical apron, and less likely to thresh out the ripe grain. The buttor apron is also done away with, the butting being ingeniously effected by means of a device which pats the end of the sheaf, and thus shapes it in the approved manner. The apron is driven by three rollers, each roller having its own driving-pinion, and is kept in place at the foot of the elevator by a long narrow guide, under which it passes, apparently with little friction. The back

of the machine is open, and therefore permits crops of any length to be cut.

*The Trent Gas Engine Co., Limited*, New Basford, Nottingham, showed a rapid and accurate Weighing Machine (Art. 3835) for weighing grain, cement, &c. It consists of a hopper, a grain vessel for receiving the grain, and the weighing apparatus, all carried on a small and convenient frame. While filling, the grain vessel is securely locked in a vertical position. Wheat, or other material to be weighed, enters by the funnel-shaped mouth until the greater part of the charge has run into the grain vessel, when a valve or flap closes, and the remainder passes in thin streams, taking the place of sprinkling by hand. The discharged port is meanwhile held closed by a flap hinged to the grain vessel, and resting on it by its own weight. When the exact weight required has entered, a second valve closes the inlet entirely, and then, by its own weight, releases the grain vessel. The grain vessel then rocks a few inches forwards and inwards, and the flap being held back by stops on the frame, uncovers the discharge port, whereupon the wheat quickly runs out. The grain vessel then at once returns to its original position, on its way taking up the flap which closes the discharge opening. The return of the grain vessel re-opens the inlet valves, after the discharge opening has been closed, and records the weighing, whilst a new weighing immediately commences.

The machine was worked in the Showyard by one of the company's gas-engines, and the greatest accuracy was obtained, a small coin being sufficient to move the balance. The machines are made to weigh from 2,100 lb. to 180,000 lb. of wheat per hour, the prices being 20*l.* and 220*l.* respectively; whilst there are, in addition, seven intermediate sizes. They would, therefore, be found very useful in granaries where considerable quantities of corn are constantly received, or would be useful for weighing out "feeds" of corn for horses in large stables. They would be equally valuable for cement sellers, manure merchants, and all dealers in dry, meal-like substances.

*Mr. William Johnson*, Castleton Foundry, Armley, Leeds, exhibited his "Stiff-Plastic" Brick Making and Pressing Machine (Art. 3675), in which are complete arrangements for mixing, pugging, moulding, and pressing. The grinding-mill is fitted with pulverisers, horizontal rollers, or perforated edge runner mills, so that whichever is found most suitable may be worked. The clay is served direct from the mill to the machine by means of a shoot, or by a shovel from a platform. The mixer and pug-mill are situated in one horizontal

line, the two operations being performed by means of an arrangement of knives fixed on one shaft. The material is delivered to the outer part of the open mixer, and is carried forward by the knives to the pug-mill, from whence it is fed into one of four moulds placed at right angles in a revolving cylinder 18 in. in diameter. The cylinder remains stationary while the mould is being charged. The action of filling the mould automatically discharges the brick already formed, and is a simple but effective contrivance. As the brick issues from the cylinder it falls into a convenient position, and is fed by a self-acting arrangement direct into the mould of the press. The pressed brick is then automatically raised out of the press-mould, and delivered in a suitable position for being loaded into a barrow or other vehicle, and taken to the kiln. The output of the machine is from 10,000 to 12,000 bricks per day of ten hours, and the cost is 300*l.* The bricks are well finished.

*Mr. Thos. Constantine Fawcett*, Whitehouse Engineering Works, Hunslet, Leeds, exhibited his Brick Making and Pressing Machine (Art. 3671), in which the pressure is applied to the bricks by means of the toggle system of levers, which gives two distinct differential pressures to each brick. The working parts, which are all made of steel, are interchangeable and few in number, and can all be seen while the machine is in work. The machine is capable of turning out a good brick in a semi-plastic or semi-dry state from fine clay, marl, shale, &c., when passed through a mixing pan to incorporate the water with the ground material. From 8,000 to 10,000 bricks can be made per day with a reasonable amount of driving-power; they are easily delivered from an open-ended moulding cylinder, and are automatically passed from it to the press, where they receive the two pressures, and are then automatically delivered on to the table ready to be taken away. The machine can be driven from either side, and made to deliver the bricks on the side that is most convenient. It is fitted to make fire-bricks and glazed bricks. There is a special oiling apparatus, which consists of a fan creating a current of air, which meets the oil as it drops, and causes it to fall in a fine spray over the open mould. The work is done steadily and well, and there is every indication that the machine is very durably made. The price is 200*l.*

*Messrs. E. Foden, Sons, & Co., Limited*, Sandbach, showed their Tandem Compound Traction Engine, with piston valves (Art. 4153). This is an ordinary compound tandem engine, the cylinders being placed close behind one another. The special feature, however, consists in the arrangement of the slide valves,

which are of the balanced piston type, so that only one steam-chest and one gland are required.

Steam is admitted through the starting valve into the space between the pistons of the high-pressure valve, and from thence into the high-pressure cylinder. After having done its work there, it exhausts on the outside of the high-pressure valve pistons, and passes at a reduced pressure into the steam-chest containing the low-pressure valves. The outer edges of these valves admit the steam into the low-pressure cylinder, whilst the exhaust takes place through the space between the valves and passes thence into the funnel. The high-pressure cylinder is steam-jacketed, whilst the jacket of the low-pressure cylinder forms the chimney base. Part of the waste heat from the tubes is used in superheating the low-pressure cylinder and steam-chest.

The arrangement is very compact, a single crank with one connecting rod being used, instead of a double-throw crank with two connecting rods.

*Messrs. Charles Burrell & Sons, Limited*, St. Nicholas Works, Thetford, Norfolk, exhibited a new type of Compound Traction Engine (Art. 4438), in which the cylinders, instead of being placed as usual one alongside the other, are placed at an angle one above the other. The pistons of each are connected to a massive steel diagonal crosshead, guided, both horizontally and vertically, by guide-bars. By connecting the pistons of the engines in this way, the extra cost of the second connecting rod and of a two-throw crank is avoided. Live steam from the boiler can at pleasure be admitted into the low-pressure cylinder should the engine get into a difficult place to start. All the motions are very conveniently arranged, and the workmanship throughout is of high class.

*Messrs. J. & H. McLaren*, Leeds, exhibited an Engine Road Locomotive with patent block wheels (Art. 4139). The block wheels (*Messrs. McLaren & Boulton's* patent) furnished the novelty, and may be briefly described as follows:—The wheels are about 7 ft. in diameter, 16 in. on the face. The periphery of the wheel is divided into 68 cells, each about  $6\frac{1}{2}$  in. square and 9 in. deep, into which hard wooden blocks are loosely fitted. The grain of the wood points outwards, and each block is bound with an iron strap, about  $\frac{3}{4}$  of an inch from the end. The blocks are bedded on an indiarubber, felt, or other pliable cushion, and are loosely attached to the wheel by a bolt let into the wooden block several inches, the head of which is covered by a wooden plug; this bolt passes through the cushion and is secured on the inner rim of the wheel by a nut. As the wheel revolves, the weight is brought to bear on part of three, four, or five blocks at

the same time, according to the inequalities of the road; the cushions give way, the bolts are pushed up, and the blocks adapt themselves to the surface of the road, so that instead of the road material being cracked out or screwed out, as is often the case with the ordinary form of driving-wheel, it is not disturbed, and the cost of maintaining the road is not increased.

The invention is one which affects machines chiefly used for traction, and is therefore not of the greatest direct interest to agriculturists; but as the cost of maintenance of country roads ultimately falls to a great extent on the land, it is not altogether unworthy the consideration of those engaged in farming. Its greatest value will be appreciated by municipal and other public bodies responsible for the state of highways, and already many of them have testified to its efficiency. Beyond the merit which it possesses in saving the wear and tear on roads, engines fitted with it are rendered more durable, for the cushions act as springs which relieve the engines of severe shaking, and thus tend to lengthen their lives, while helping to counterbalance the disadvantages of the extra  $1\frac{1}{2}$  tons added to the weight of the engine, and the additional cost of 100*l.*, which is the price of a set such as has been described.

*Messrs. T. C. Darby and J. E. Stevenson*, Pleshey Lodge, Chelmsford, showed their new Steam Digger and Cultivator (Art. 4292), which is a decided improvement on the machine which has hitherto been known as the Darby digger. The old digger had a broadside action, weighed 20 tons, and cost 1,200*l.*, whereas the present machine has a rear action, weighs only 8 tons, and costs but 600*l.* By placing the tines in the rear, the rollers are relieved of a great portion of the weight of the machine, for the force required to make the tines enter the ground naturally lifts the machine to some extent, and the objectionable compression of the soil, which is the chief drawback to the popularity of digging-machines, is much lessened. As the machine under notice has only two-fifths the weight of the old one, it possesses an advantage which must prove beneficial to the land worked. The price is so much reduced that it comes within reach of many who would not care to risk the large amount of capital required for the old machine. The piston-rods are coupled up directly on to the digger-crank-shaft, thus avoiding intermediate gearing-shafts and the fly-wheel. The thrust of the tines is made at a very good angle. Another new feature is the introduction of coulter placed immediately behind the digging-forks; the soil is thrown sharply against these coulters, and the bigger clods are broken; while the coulters level down the surface so as to render subsequent work-

ing more easy. The working parts are all conveniently under the control of the driver, the steering being done by means of hydraulic power, thereby relieving the steerer of all hard work.

*Messrs. Charles Clay & Co.*, Stennard Works, Wakefield, showed a Horse-rake (Art. 786) in which the clearing-rods are so attached that they give active assistance in freeing the teeth of their load, whereas in other machines they are rigid. The rods are hinged to the framework on the main axle of the rake, and by connecting-links with the leverage, so that while the teeth are being raised the rods are depressed, thus pushing out and delivering the load more quickly, and with a shortened action of the levers. As the weight of the teeth is to some extent compensated by the weight of the rods, there is a corresponding decrease in the power required to work the levers. A simple arrangement makes the teeth rigid if it is at any time desired. The strength of the machine is not impaired by the new action, and the cost is the same as for the ordinary type, 10*l.* 10*s.*

*Messrs. West & Co., Limited*, Devons Road, Bow, E., showed their Chaff-cutter, with which is combined an apparatus designed to take out dust from chaff (Art. 3793). The apparatus is simple in construction, but achieves its object in a thorough manner. The chaff from the chaff-cutter is conducted to the hopper of the aspirator by means of an elevator, or may be allowed to fall direct into it, according to circumstances, for the apparatus may be fixed in almost any situation without destroying its efficiency. A fan, driven from a pulley placed conveniently above the chaff-cleaner, is placed inside the trough, near to the end farthest from the hopper. The trough is L-shaped, the shorter, vertical side being connected with the hopper; the chaff falls down this vertical side to an opening below, and during its descent it is acted upon by the fan, which, while not sensibly affecting the chaff, frees it from the dust which is mixed with it, the fine particles being withdrawn and deposited along the horizontal portion of the trough. The chaff is controlled by slides during its progress through the machine, which is so contrived that no gauze is used, thus avoiding the risk of blocking, which is very great when light particles are drawn up against small meshes.

Although chaff-cutters are made with efficient sifting apparatus, which will take out much that is detrimental to animals, there are light portions which are not eliminated by the sieves, and can only be separated by means of a blast. Ordinary blasts are wasteful, as they blow out particles of chaff as well as dust, and they leave the barn or chaff-house in a dusty condition: these two objections are avoided in *Messrs. West's* apparatus.



Dusty chaff, whether made so by fungoid or by other foreign matter, is known to be injurious to animals, and horses are particularly subject to ailments caused by it. If the dangerous dung-ball does not originate from dust, it is greatly composed of it; and it is a well-known fact that dust has a very bad effect on horses' wind. Therefore, as the chaff-cleaner frees chaff from light impurities, its value may be readily appreciated by those who have horses under their control. The apparatus may be fitted to any chaff-cutter, and it varies in price from 8*l.* for hand machines, to 20*l.* for larger machines attachable to large chaff-cutters.

Messrs. George Cotton & Co., High Town, Middlewich, have introduced a simple and useful improvement in the construction of milking-pails (fig. 15). Their Self-holding Milking-can (Art.

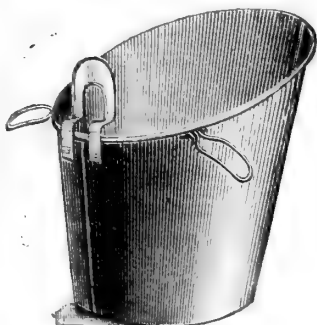

FIG. 15.

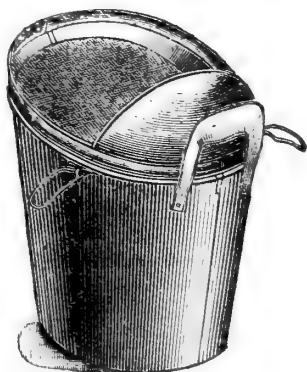

FIG. 16.

Self-holding Milking-cans.

1075) is made with two hinged rests or handles, which are curved so that they fit easily on to the legs of the milker, just above the knees. The can is thereby suspended, and is kept in position without any effort on the part of the milker, who is much less hampered than when he is in the cramped position which is enforced in using the ordinary pail. The rests not only move up and down, but they slide along if it is required to vary their position. A section of the pail shows that the two sides are not placed at the same angle to the ground, but the fore portion extends outward to make a bigger 'catching' surface, and at the same time forms a convenient lip for pouring out the contents of the vessel. It is said that women engaged in milking suffer by having to keep a long-continued grip on the ordinary pail, and as the gripping is entirely obviated, there is no reason why the complaint should exist any longer, for

though there are such decided advantages in the new form of pail, the cost is no greater than for pails of similar size but of different construction. Fig. 16 represents the pail fitted with a wire sieve, to keep impurities away from the milk.

*Messrs. Fairbairn & Jones, Wyke, Bradford, Yorks,* showed a Sod and Turf Cutter (Art. 1028) which does its work more simply and more easily than any implement we have seen. To the fore portion of the frame, which is not unlike a lawn-mower, is attached a roller divided into two cylinders; and between the cylinders a revolving steel disc is fixed to make the vertical cut, in a similar manner to the disc-coulter of the plough. At some little distance behind the roller is a broadshare, shaped like a V-hoe, 12 inches in width, carried on a stem which can be set at any height to regulate the thickness of the sod. This share makes the horizontal cut when the machine is drawn through the land. On getting to the end of the draught the implement is run back parallel to the first draught, and pares another 12 inches of turf. Twenty-four inches of turf are thus cut, and the vertical disc has made two cuts resulting in a sod 12 inches in breadth being cut out cleanly, and half a sod on each side being also cut, so that after the first bout a sod 12 inches in breadth is cut out at every draught. Other attachments for stirring the sod and breaking it up may be fixed on the frame. The cutting is done very easily and most perfectly, and it is doubtless a valuable implement where large quantities of turf are to be moved, but its application to strictly agricultural operations is somewhat limited. It is priced at 7*l.* 10*s.*, and will pare 2 acres per day.

*Messrs. Allan Jones & Co., Hatherley Works, Gloucester,* showed their new "Hatherley" Chicken-rearer (Art. 990), which is worthy the attention of those who engage in poultry-rearing by the aid of artificial appliances. The leading feature in the "Hatherley" rearer is that a current of pure heated air is passed through it, and all cold draughts are avoided. The foul fumes from the lamp cannot enter the partitions in which the chickens are placed, thus ensuring their good health. All parts are neatly and skilfully arranged, and the rearer is so simple that the most inexperienced hand can superintend its management, whilst it is an ornamental feature in a small farmstead. Its price is 5*l.* to hold 50 chickens, and 10*l.* to hold 100.

The Judges desire to express their obligations to the Stewards of Implements and to the Surveyor, through whose courteous efforts the discharge of their duties was greatly facilitated.

## THE FARM PRIZE COMPETITION OF 1891.

THE very interesting and instructive custom of having a Farm Prize Competition in connection with the Royal Agricultural Society's Annual Meeting was continued for the year 1891 by the offer of the Doncaster Local Committee of the liberal sum of 300*l.*, to be competed for by tenants holding occupations of various sizes, divided thus :—

CLASS 1.—For the best-managed ARABLE and GRASS FARM of 200 acres and upwards, of which not less than one-half shall be arable. First prize, 50*l.*; second, 30*l.*; third, 20*l.*

CLASS 2.—For the best-managed ARABLE and GRASS FARM above 100 acres and not exceeding 200 acres, of which not less than one-half shall be arable. First prize, 50*l.*; second, 30*l.*; third, 20*l.*

CLASS 3.—For the best-managed ARABLE and GRASS FARM above 40 acres and not exceeding 100 acres. First prize, 50*l.*; second, 30*l.*; third, 20*l.*

The Council appointed as Judges to inspect the farms: Garrett Taylor, Trowse House, Norwich; and William Coulman Brown, Appleby, Lincolnshire. It was intended that the first visit should be made early in January, but the severe weather caused a delay of quite a month.

The competition was limited to farms within the boundaries of Yorkshire, and, as will be seen, that county, the largest by far in England, contains farms as diversified and some of them as well managed as any in the kingdom.

Even on the competing farms the greatest contrast possible was observed by the Judges. The deep loamy soils at Catterick, where the plough could and did reach ten inches, are almost historic, situated in that noted Vale of Mowbray in which some of the inhabitants believe, and perhaps rightly, the finest farms of the kingdom are to be found.

Then, at the opposite corner of the county, at North Dalton, a high wold country presented itself, where on many an acre 4 inches of soil at the most is all that can be turned over. Indeed, the surface of some of the fields is nearly white, being composed almost entirely of fragments of the prevailing chalk; and yet, since the introduction of bone manures, &c., excellent turnips and barleys are grown, with the assistance of large flocks of sheep, which on such land were in good times reported to "tread with a golden hoof."

Regret was expressed in all quarters that the number of entries should be so small. No representative put in an appearance from the great Warp district, where thousands of acres of

potatoes are grown, of high quality, and much liked in the London markets. Such immense sums are spent in manure, both natural and artificial, and so great are the pains taken in the working of this land, that market-gardening would be a more appropriate term than farming.

The large growers plant as many as 300 to 400 acres, some of them having their land absolutely clean, besides producing such crops of wheat and clover after the potatoes as can scarcely be equalled in any other district. Had the best of these holdings been entered, they would have certainly come to the fore in the competition.

The greater portion of this land has been artificially warped by turning the muddy tidal waters of the Trent or Ouse upon the land. In some cases many feet of alluvium are deposited in the course of two or three years, the usual time taken for this operation.

Contrary to what a stranger would expect, large floods coming down from the upper reaches of the rivers only tend to dilute the water, and reduce the quantity of warp, which is deposited much more freely in dry summers.

The Judges found, even on their first visit of inspection, that many pieces of land had been sown down to grass, generally on the stronger farms, or on the heavier portion of them, but in only a few instances had any attempt been made to use proper mixtures of grass seeds. In reply to queries on this matter, the answer usually was that one or two quarters of Penistone hay-seed had been sown, with perhaps 7 or 8 lb. of mixed clover. The term Penistone hay-seed in Yorkshire means the sweeping up of the seeds from the bottom of hay barns, &c., and it is but fair to say that it was at least a debatable point whether these or the advertised prescriptions resulted in the best permanent pasture.

Very good swedes were noticed on several of the farms, one hundred grown by Mr. Hutchinson weighing about  $9\frac{1}{2}$  cwt.

In a few cases on the Prize Farms great judgment was shown in the selection of manures containing the elements due to each variety of crop, the very requisite analysis also being often obtained to check the value of the bulk on arrival.

In many instances the Judges feared that much money had been needlessly thrown away, by the misapplication of most expensive fertilisers, and by their purchase under the vague term of "Special" or some similar description, without the least guarantee being given or asked as to their probable ingredients, or their suitability for the crop.

Two little-known manures were met with, and were in each case used in very large quantities; they were strange to the

Judges, so Dr. Voelcker was asked to report upon them, which he kindly did, and the analyses, &c., are given below.

The first, "sud-cake manure," was found to be the solid refuse resulting from the process of washing the foreign wools at Messrs. Isaac Holden & Sons' Mills, where there are about 60 tons per week to dispose of. Large quantities, a boat-load or over, were spread upon the grass-land, and its frequent application had no doubt in the course of years much improved the face of the fields. Its condition was admirable for even distribution.

The second sample, "fleshings manure," is a refuse from tanneries or glue works, being composed of portions of skins and hair, and also lime which had been used to loosen the latter. This manure had a very good appearance, but was so very difficult to spread and knock to pieces, besides having a most abominable smell, that unless it can be put out in a better form, its use will not become general.

Very large dressings on one farm were spread upon the fallows and ploughed in. Two cart-loads were thrown on about one rood of mixed seeds for mowing, and the visible result was certainly very great, the produce appearing to be almost doubled. It is but fair to say that the seeds had been pastured somewhat too late, and no doubt the sheep would reject the manured portion. The opinion resulting from the report of the Consulting Chemist of the Society is not too favourable to the use of such bulky and cheap materials, good straw manure being recommended in preference if it can be obtained easily.

The composition of the two samples was given as:—

	Fleshings manure	Sud-cake manure
Moisture . . . . .	42.78	27.59
<sup>1</sup> Organic matter . . . . .	38.44	15.88
Phosphate of lime . . . . .	—	1.19
Carbonate of lime . . . . .	—	4.07
Sulphate of lime . . . . .	12.49	—
Oxide of iron . . . . .	1.93	—
Sand . . . . .	4.36	51.27
	100.00	100.00
<sup>1</sup> Containing nitrogen . . . . .	3.22	1.52
Equal to ammonia . . . . .	3.91	1.85

Amusing inquiries had occasionally to be made in the walks through the fields in order to obtain a free translation of sundry words used, the Judges, hailing from Norfolk and Lincolnshire, as well as the Yorkshiremen, all giving and taking slight explanations as required. For instance, a nice little shed in the fields is a "tuffil"; then there was not sufficient room to "seal"

as many cows as required in the "byre," the liquid running from the "groug" (*ou* as in south) into the "soar" tank, the solid "manner" being spread on the "forf" (fallows). Some sheep, one hundred, or "cloise" on that, required either to be docked, clagged, belted, shirled, or dodded. That's "us" blacksmith's shop, where the hoes can be repaired with which the "poppies," "headaches," "red-weed," "wickens," "twitch" and "couch" could be cut out, that operation being often termed the "spring corn is going to be 'louked'" (*ou* as above). In the East Riding, round stacks are "pikes," and "ketlocks" or "charlocks" are there "brassicks," the classical ring about the latter word being interesting.

A list with particulars of each competing farm is given on the opposite page. From the table it will be noticed that the tenures are all yearly, and most of the occupiers have agreements giving a portion of the corn acreage as following crop, or some condition allowances in lieu thereof.

Owing to the very large sum required to pay the valuation on a farm, especially in the neighbourhood of Doncaster, many exceedingly nice holdings had been unlet, and some were still unoccupied, others again were only farmed by non-resident tenants; and it was painful to see very large and good houses without the slightest attention paid to them, the gardens having rubbish one foot high, or grazing sheep.

The remark was made by a well-known local man that strangers were generally frightened by the excessive expense at entry, and only tenants bred and born in the district could be obtained.

The competitors used every endeavour to supply information tending to show their profit or loss during the last few years, but as complete accounts could not be obtained except in a few instances, nothing can be published in tabular form that would be interesting. It is but due, however, to say that Mr. Merryweather in the second class, and the Messrs. Hinchcliff in the third, presented in every particular such accurate and complete accounts, coupled in each case with valuations at the end of each year just as if they were leaving, that it was a treat to examine them.

The books of one or two of the other prize-takers might be mentioned, but in less high terms than the above. The Judges, however, satisfied themselves on this point, as they were bound to do, by the conditions under which each competitor entered.

FARM PRIZE COMPETITION, DONCASTER, 1891.

No.	Name of Competitor	Address	Acreage		Nature of Soil	Nature of Subsoil	Nature of Tenure	Remarks
			Arable	Grass				
<b>CLASS I.</b>								
1	Hutchinson, T. H.	{ Manor House, Catterick, Richmond } { Woodfield Ho., Robin Hood's Well, Doncaster }	a. r. p. 354 0 0	a. r. p. 246 0 0	{ Light and Heavy }	Gravel and Clay	Yearly	1st Prize
2	Lodge, Joseph.	{ Melton Brand, Doncaster }	259 0 0	72 0 0	Limestone	Rock	Yearly	—
3	Parkin, Smith Eyre.	{ The Manor House, North Dalton, Hull. }	287 0 0	143 0 0	Limestone	Rock	Yearly	Commended
4	Staveley, John Alfred	Newton, Doncaster .	766 3 0	80 2 0	Light	Chalk	Yearly	2nd Prize
5	Townend, James .		180 0 0	102 0 0	{ Limestone mixed }	Rock	Yearly	3rd Prize
<b>CLASS II.</b>								
6	{ Merryweather, Andrew } { Stanley, John . }	Whiston, Rotherham . Campsall, Doncaster .	88 1 25 125 2 9	26 1 6 34 1 8	{ Light and Heavy } Light	Stone and Clay Limestone	Yearly Yearly	1st Prize 2nd Prize
<b>CLASS III.</b>								
8	{ Hinchliff, Joseph } { and William . }	{ Lady Oak Farm, Embley, Wakefield . }	54 3 13	28 3 13	Heavy	Clay	Yearly	3rd Prize
9	Kent, Samuel .	{ Barmborough, Doncaster . }	58 0 0	22 0 0	Heavy	Clay	Yearly	—
10	Strickland, Tom D..	Carlton Miniott, Thirsk	62 2 0	14 0 0	Light mostly	Gravel	Yearly	1st Prize
11	Walsh, William .	Gilstead, Bingley .	25 2 0	50 1 20	{ Light, heavy, and black }	Clay and sand or gravel	Yearly	2nd Prize

## CLASS I.—FIRST PRIZE FARM,

*Occupied by Mr. Teasdale H. Hutchinson, The Manor House,  
Catterick, Richmond.*

The honour of gaining the First Prize in the Farm Competition of the Royal Agricultural Society of England is a great distinction, which any one might covet; but on this occasion Mr. Hutchinson holds the proud and unique position of taking the prize for the second time.

Eight years ago, in 1883, when the Royal Show was held at York, a portion of the present holding, which has been in the family's hands more than fifty years, obtained a similar honour to that now gained. Since that date 350 acres have been taken from the same landlord, Sir John Lawson, Bart., of Brough Hall, Catterick, and as the boundary fences were conterminous, the whole 600 acres have the appearance of having been under one management all the time. The newer portion was taken in 1888 only, so about one-fourth of the arable land has in its turn to go through Mr. Hutchinson's drastic mill; and when once it has passed through his fingers, explanations that he has only had this portion or that for four or five years are neither made nor required.

Absolutely clean is a verdict one scarcely likes to pass as a sentence on a farm, but here we give it. Yet, as every rule has an exception, so it was in this case, for the senior Judge, after dragging his colleague over miles of fallows, at last found one solitary piece of twitch, and, holding it up, sarcastically asked what it was. Great was his discomfiture when the competitor with ready wit invited him to find another.

The Manor House was reached after a long drive of twelve miles from Northallerton through that world-famed country, containing such names as Warlaby and Bainsesse and others, the homes of the Booths and the Outhwaites, at once the very cradle and meridian of a tribe of Shorthorns which has spread over the whole world.

We were promptly conducted through a perfect maze of buildings, the geography of which was not well learned after three visits; the plans of the greater portion of them are given in a former Journal.<sup>1</sup>

Mr. Hutchinson has now spent upwards of 2,500*l.* in improving, altering, and building on his landlord's premises, without any security, and even without any agreement. These additions are all carried out in the most substantial and permanent style,

<sup>1</sup> Vol. XIX. s.s. 1883, Part II, p. 557.



under his personal and direct supervision, which is much preferred to the work executed by the landlord with borrowed capital, for which about 6 per cent. is charged, a like percentage being paid on a large quantity of draining.

A minute description of the buildings, of which there are

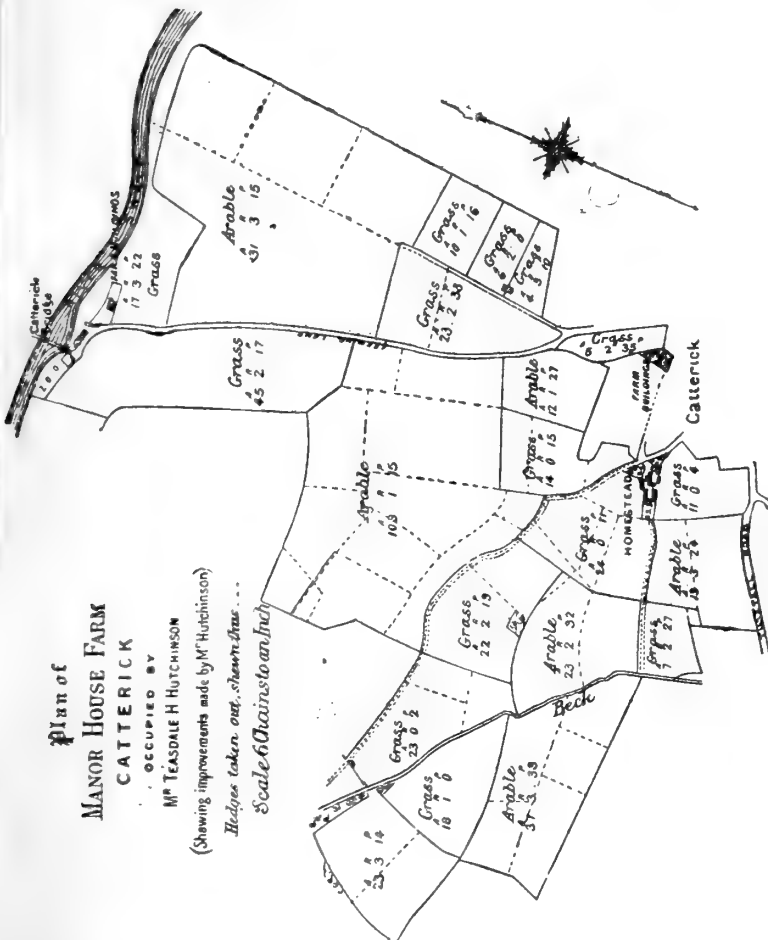

three sets of varying size, would be somewhat tedious, but a striking feature is the large number of loose boxes required for the accommodation of the horses and young bulls. In all, the ventilation is perfect, a supply of cold fresh air coming in near the floor, and the heated atmosphere escaping at the top.

Covered yards are also a great feature at Catterick, as in

January the stock was all housed, with the exception of one small open yard, much surrounded by buildings, and very warm, containing 8 or 10 nice bullocks; and this was on the new portion of the farm, where every yard has been attacked and roofed in, besides a general pointing up and repair, which must have cost the tenant a good round sum.

A most useful and commodious shed, with a small cake store at the end, was just completed, at some considerable distance from the homestead, and will prove convenient either as shelter in lambing time or for cattle in summer, besides being an adjunct to the large arable field on the boundaries of which it is built. Dutch barns are much advocated by Mr. Hutchinson, a large one, 55 yards long, having still large stores of hay in it. A smaller one, 18 feet high, was nearly finished in June, and, being boarded on one side, would perhaps be of use for stock at times as well as for hay. The cost of the above was 120*l.* and 30*l.* respectively.

The requirements of a large head of stock necessitate the almost continuous help of steam for chaff-cutting, pulping, &c., and the arrangement of the numerous and varied machines, with their different convenient stores for chaff, corn, meals, &c., was most admirable.

An eight-horse portable engine is at work every day in winter, and the driver deserves praise for the condition in which it is kept, the glands and bearings being in perfect order, and running as noiselessly as if fresh from the works.

The threshing machine, which is semi-fixed, is so arranged as to deliver and weigh up the corn in the barn, besides getting rid of the straw and refuse with the smallest amount of labour, which is the case also with the chaff-cutting, pulping and grinding of the corn, all for mixing in varying proportions for the stock in the yards and boxes contiguous.

— Two large chaff cutters, one for horses the other for cattle, a pulper, a pair of stones, a crusher that will serve for either oats or linseed, a cake breaker, hoists, a saw table, and a grindstone, make up a list more for a factory than for a farm, and all are worked by the engine. The waste steam is not lost, but is led by a pipe and used to cook some of the food for the stock. More expensively erected sets of barn machinery may be seen, but for completeness and usefulness nothing better can be wanted.

The land is a little varied, but consists mainly of a nice workable loam, mixed in some places nearer the river Swale with a perfect covering of round stones, tons of which have been removed, only to make room for more. A portion stronger than the rest, and at the far end of the farm, has been laid down to grass with

Mr. Faunce de Laune's mixture, without rye-grass, large dressings of bone meal being applied.

The application of farmyard manure to a previous crop a year or so before still showed its effects in the new grass, there being as a result a thicker and better plant. So large an area of old pasture as 246 acres could but be of varied quality, some being hilly and rather rough, on which was wintered a number of young horses, receiving hay during the severe weather. Another and exceedingly rich pasture contained over a score of magnificent bullocks, receiving about a cake per day, half linseed and half cotton.

On the racecourse and other fields large numbers of nice two-year-olds were running, which had some of them been brought for the covered yards to replace others that had gone out at 27*l.* each. More had been picked up in lots during the autumn and winter, kept in store condition in the covered yards at the new farm, and then were grazing and would be sold out fat during the winter.

Proceeding further to the turnip fields, the hogs were seen, consisting of about 400 Leicesters and Border Leicesters, having, besides cut swedes, about  $\frac{1}{2}$  lb. of cake with pease. They were evidently in a very thriving condition.

Two hundred and twenty-five ewes, consisting of 80 pure Leicesters and 145 Border Leicesters, were penned by themselves on a piece of green globe turnips, which had been a grand crop, though the winter had made sad havoc with it.

The whole of these sheep, as also those grazing on the seeds in the summer time, were fenced in entirely by galvanised wire-netting, the great objection to which usually is that it sets badly owing to being machine made, and is often longer at one side than the other; the strands also run length-way of the net, aiding its tendency to sag down between the stakes, showing badly by contrast with the taut appearance of a well-set hemp net,

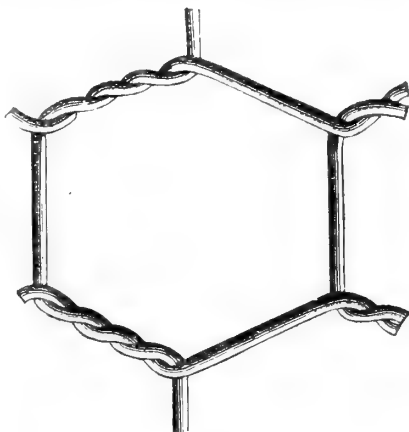

FIG. 1.

After repeated inquiry as to why Mr. Hutchinson's wire net always appeared such a good fence, it was found on the third visit that the nets were all hand made, and the wires of extra thick gauge, and the reason they stood so upright was owing to a wire being worked from selvage to selvage, whereas in the machine-made net they all run longitudinally. Russell, Grassmarket, Edinburgh, is the maker, who of course charges a little extra for hand work, which will be amply repaid in the long run. The illustration (fig. 1) is that of a single mesh.

The fallow land to be sown with swedes was being ploughed ten or twelve inches deep, with a correspondingly wide furrow, four grand horses being yoked to a chilled plough, or digger as it is sometimes called, and making splendid work. These implements, several sorts of which were on the farm, are much liked, and nothing else could have produced such a result.

In returning through the stackyards, large quantities of swedes were seen stored, the plan being to commence if possible near a wall or a stack of straw, and make the heap approximately three feet high, with a level top, over which is thrown a certain thickness of old straw or waste chaff, and no earth. We were surprised to find that, after such a winter, all the roots were sound. A small walled enclosure at the new farm, we were informed, was used entirely for this purpose. No doubt a certain amount of heat will be generated in a heap of such a size, not sufficient to cause the swedes to rot, but evidently quite ample to ward away the frost.

The enormous size of the swedes, both under the straw and in the fields, arrested our attention, and Mr. Hutchinson, after mildly suggesting 50 tons per acre, was requested to weigh one hundred of the best, which turned the scale at 76 stones, or nearly half a ton.

A woman was trimming them in the fields at one penny per 100 yards of row, making good wages. An implement is at times used to loosen the roots, somewhat similar to that figured in the article upon sugar-beet cultivation in Austria. (See p. 347.)

Mr. Hutchinson has almost altered the face of the country by stubbing up miles of fences in the arable land, besides clearing away 80 or 90 trees in one part only, forming, as will be seen by the plan, a much more workable holding. Wire netting does not harbour vermin nor encourage rubbish, and with that to aid him the tenant would almost like to have all in one field only, except the grass, which of course must be divided by fences.

An old wooden Dutch barn in the field, and a long piece

of road, were deemed to be in the way and to offend the eye; on our third visit the land they had occupied was growing swedes.

With regard to the cropping of the land, the ordinary four-course system is departed from, and an extra crop of corn taken here or there as thought expedient, the large amount of manure used almost necessitating such a plan. As the very fullest crop is always looked for, however, a slight top dressing is occasionally required to reach Mr. Hutchinson's idea of a good crop.

In 1890 the land was divided as follows; this season a few more oats are grown:—

Roots, 99 acres.	Oats, 5½ acres.
Wheat, 51 acres.	Clover, 68 acres.
Barley, 85 acres.	Meadow mown, 22 acres.

Nearly the whole breadth of roots consists of swedes, the land being manured with twelve loads of dung, which is turned in with the chilled plough. It is then ridged, the artificial manure sown by hand, the rows are next split, and a finish is made by sowing the swede seed by the Scotch drill. The quantity of manure broadcasted usually is 2 cwt. guano, 2 cwt. bone meal, 2 cwt. rape dust, 1 cwt. kainit, 1 cwt. nitrate of soda. This somewhat strong dressing is varied according to circumstances, and according as dung is used or not in the rows.

The system, and the mode and time of sowing, resemble the Scotch style of operations more than those in the Midland Counties.

At the second visit, on April 28, the whole of the swedes were sown on one of the farms. On June 15, many were singled, as well as the mangel, and would no doubt by the aid of the late rains result in as good a crop as last year's.

Very good pieces of wheat were shown, which are usually grown after oats, and top dressed if required, but, as will be seen above, a much larger breadth of spring corn is put in than of wheat. The barley, consisting of several well-known varieties, was in splendid order, as well it might be, being sown after the swedes, which, large as they are, cannot have nearly abstracted all the manurial properties out of the land. The most successful corn crop, however, grown on the farm is the oat, the soil and climate no doubt suiting it admirably. Mr. Hutchinson only grows one sort, saying it does better than any other; it is a white variety, which he has had many years, and calls "Catterick Hero." To judge by the sample inspected, as also by the appearance of the growing crop, which was such as is seldom seen, a greater demand than even that now experienced will spring up for such good seed.

Rather small quantities of seed are sown, 8 pecks only of

wheat and barley, and 11 pecks of oats, the distance of the drills being nine or ten inches, thus giving plenty of room to do any weeding required; whilst the Judges could also, for the same reason, see and say that the corn was clean.

The sheep pastures on June 15 were well stocked, but the strong clovers were completely master of the sheep, and looked better than some pieces do for mowing; rye-grass as a rule is not used nor liked, but 14 to 16 lb. of clover alone, viz., 6 lb. white clover, 4 lb. red, 2 lb. alsike, 2 lb. cow-grass. A piece for cutting green for the stock in the yard had been sown with 5 lb. red, 5 lb. white, 5 lb. cow-grass, and 2 lb. Italian rye-grass, and was yielding a very heavy weight per acre, measuring over two feet high as it grew.

The following is a list of all the stock on the farm, which varied slightly at the other visits, in consequence of the sale of some bullocks and fat hogs.

28 Cows in calf or in milk.	10 Shire horses.
12 Heifers, bulled.	7 Clydesdales.
54 Fat bullocks 2½ to 3 years old.	16 Hunters.
34 Heifers and bullocks, rising 2 years.	1 Hunter brood mare in foal.
23 Yearlings and calves.	1 Hack.
6 Bulls.	1 Pony.
—	—
157 Cattle.	36 Horses.
	80 Pure Leicester ewes in lamb.
	145 Border Leicester ewes in lamb.
	403 Hoggets.
	8 Aged rams.
	—
	636 Sheep.

With the exception of the cattle previously mentioned, and a grand lot even they are, the whole of the above stock is pure bred of its kind, being in the herd-book, or eligible. Each tribe, and in many cases each animal, has a history of its own, and would require a special article for its description, instead of a mere cursory glance such as this.

The herd of Shorthorns consists of upwards of 50 head of all ages, entered and eligible for entry in the herd-book, from *Lady Putely*, now 16 years old, down to her own calf, which is the fourteenth she has bred and reared. This cow is half-sister to that world-renowned *Lady Pamela*, who won in prizes alone not less than 750*l.* *Lady Gray*, a magnificent specimen of the herd, is the dam of *Lady Golightly*, sold to go to South America for 500 guineas.

*Lady Playful*, *Lady Alicia*, *Lady Louise*, *Lady Gray*, and *Lady Golightly*, have all been Royal winners, and with them the

champion prizes for the best female in the yard have been obtained at Kilburn, Derby, York, Norwich, and Newcastle-on-Tyne. Several grand calves in a nice box were being reared by their mothers, one especially being noticed, a beautiful roan heifer calf, out of *Lady Adela*, which, if brought forward for show, would most likely make a mark in the ring.

The G tribe has at its head that fine cow, *Glad Tidings*, so well known at the Royal and all the leading shows, where she took prizes. A splendid bull out of her, *Guy Hutchinson*, is sold to Warlabay, and now let out for hire to the Duke of Northumberland. A few representatives of other tribes are on the Manor House Farm, notably some of Scotch blood, purchased of Mr. Maw, Upper Mill, Aberdeenshire; but they are not considered to have the style and high-bred look of many of the favourite G's and Ladies.

The bull in use at the head of the herd is *Sir Roger Studley*, a rich roan deep-fleshed bull from Warlabay, a fine representative of that famous herd.

As the young bulls are in such demand, they are sold as soon as they come to useful age, three being seen just before their shipment to Sweden. Others have been exported to Australia, France, Germany, and elsewhere.

Mr. Hutchinson, as every one knows, believes in "pedigree," but if in his judgment any female in the herd does not possess heavy flesh, and other good qualities, she is not retained, be the blood ever so blue; and that "judgment" need not be questioned, when the prizes taken at the great shows, not only for cattle, but also for horses and sheep, mount up in value to more than 9,000*l.*

The noted flock of Leicester ewes is still kept up, and is in as grand form as ever, prizes having been won at the Royal since our visit to Catterick.

Since taking the new farm, a flock of Border Leicesters has been added at great expense, 94*l.* being given for a magnificent ram, to which a friend sent 20 ewes, paying 20 guineas as the fee. Sixty gimmers were also purchased, some of them costing 12*l.* each, making altogether a good round sum paid for the foundation of a flock.

The gimmer hogs kept for breeding were running on the grass near the River Swale, and on looking through them it was at once seen what an even lot they were. A few at a nice figure have been sold to go to South America.

The different noted rams were usually in pens in a large shed, where Chisholme, the old shepherd, was ready to do the honours of showman. Prize cards from the different shows liter-

ally covered every beam of the building, some of the older ones dropping off, but there are enough and to spare to fill up the gaps.

Mr. Hutchinson having been so successful with hunters, it was found, as expected, that a good many were kept on the place, and they often sell at a high figure, after being trained by so noted a rider.

Seventeen horses for the farm were shown, consisting of ten Shires and seven Clydesdales, many looking more like show animals, instead of possessing the appearance of having the hard work to do on a large farm. Four were especially noticed just after their dinner hour, going out to make such capital work with the chilled plough as mentioned above. To notice one or two more particularly, the Clydesdale mare, *Milkmaid*, has taken more than 40 prizes at the great shows, and was purchased from Lord Londonderry for nearly 300*l.*

The Shire mare, *Orange Girl*, has been exhibited twice, and has taken two prizes, as also has *Myrtle*, by *Bar None*, a fine brown mare, the dam of *Clifton*, sold at Lord Londonderry's sale to Mr. D. Riddle for 500 guineas. These and other mares have good foals by their sides, by the best horses that can be found, and as early as April 28 the mares had to leave their foals in the box, and go out and take a share in the work.

A few pure-bred game fowls and Wyandottes were seen, as also a fox terrier, *Member*, by that noted champion, *Result*, for which it is said 1,000*l.* was refused. Care and breeding are thus continued down to the bottom rung of this prize ladder.

#### CLASS I.—SECOND PRIZE FARM,

*Occupied by Mr. J. A. Staveley, North Dalton, Hull.*

A very large tract of land in the East Riding of Yorkshire, reaching down to the Humber, and again over the water in Lincolnshire, is underlaid entirely by chalk, which reaches to a very great depth, and wells in many cases have to be sunk sixty to eighty yards before water can be reached, necessitating special pumps and small horse-gears to supply the daily wants of large herds of stock. A water-cart, and often a water-waggon with two horses, may be seen at the noted pump in the market-place at Barton-upon-Humber in the summer time, whilst one or two others wait patiently for their turn.

This district is called the Wolds, and Mr. Staveley's farm is a good example of the system of treating such thin chalky soil in both counties. Indeed, when walking over the large fields, most of them fifty acres, one could easily fancy that it was the





and are grown, and contrary to expectation, the immense body of chalk causes a coolness of soil with a resisting power to drought, unknown to those living on the oolitic limestone formation.

North Dalton is a small village near Market Weighton, the owner being Lord Londesborough, between whom and his tenants a most excellent feeling prevails. A railway station having been very recently opened at Middleton-on-the-Wolds, great ease is now felt in the delivery of corn, which formerly had to be taken many miles to Driffield.

The size of the farm is 857 acres, eighty acres of this being grass, and 767 acres arable. A modified four-course system is followed, varied again at the high portion of the land, but always having a good turnip crop in view to support the large flock of sheep, without which these Wolds could not be farmed.

Great quantities of straw must of necessity be trodden down in the winter, for which many large open yards are provided, one of them recently covered, 20 yards by 16 yards, at a cost of 80*l.*, with the usual interspaced deal boards.

The buildings, premises and fences were in very nice order, having altogether a tidy appearance, yet showing none of that extra preparation sometimes seen on a competing farm.

To obviate the scarcity of water mentioned above, large ponds are made at great cost, no little skill being required to keep them water-tight. A very good one, costing 30*l.*, has been made at the corners of four fields. After digging out to the required size, a coating of lime is evenly spread, then a thickness of clay well worked, after this another layer of lime followed by straw, and over all plenty of chalk. The lime is used to prevent the worms letting the contents flow out. Although the weather was so dry, plenty of water had collected from the rainfall and surface water, and had every appearance of remaining there until required.

The corn crop being such an important item on the farm, its serious depreciation of late years has told heavily on the receipts, and although the rent has been reduced from 1,150*l.* to 834*l.*, yet, as will be seen by the gross value of the cereals sold for the last 14 years, diminished rent only very partially atones for so great a fall in prices.

*Returns of Corn of all descriptions sold each year.*

1877 . . . . .	£2,701	1884 . . . . .	£2,537
1878 . . . . .	2,004	1885 . . . . .	1,293
1879 . . . . .	1,537	1886 . . . . .	1,034
1880 . . . . .	1,343	1887 . . . . .	1,561
1881 . . . . .	1,894	1888 . . . . .	895
1882 . . . . .	1,964	1889 . . . . .	1,608
1883 . . . . .	1,966		

The cropping is varied, as follows, on the Ardenfleets, or far end of the farm, which is higher and thinner land than the rest: after seeds with rye-grass, left down two or three years, oats are sown, then turnips, manured in the ridges and phosphates added, next barley with seeds. Or, if slightly better land, clovers without rye-grass if followed by wheat, then turnips, and oats or barley. On the village farm, wheat is followed by barley, turnips, oats and seeds, the second crop of corn being omitted at times. at others a crop of pease is inserted to freshen the land for seeds and turnips.

The seed land is all manured after the ewes and lambs have nearly finished, and is sown with various wheats, viz.: Hybrid King, Square Head, Golden Drop, and sometimes mixtures of the above. The barleys chosen are Golden Melon, Chevalier, Prize Prolific, Awnless, and Goldthorpe, the last named being a short-eared close-set barley, much sought after at present. The oats include Tartary, Asia Minor, and Victoria. Fresh seed in small quantities is periodically obtained and grown for use the next year, thus providing change for all the different fields.

A little discretion is required in providing food for the sheep in the autumn and winter, 15 acres of rape being first grown for the lambs, followed by small breadths of Grey Stone, Purple Mammoth, Red Globe, and White Globe; the main breadths being occupied by the Green Globe, after which come the hybrids and swedes. The first mentioned are most useful for a time, but if ten acres too many be on hand, they soon possess the qualities of a large sponge rather than of nice crisp turnips.

Not much mangel is grown on the Wolds, but an acre or so proves useful in the spring, gaining in quality what is lost in size on such thin soil. If ridged the roots are sown 26 inches apart in the row, and 2 feet apart if on the flat.

The artificials used this year for swedes consisted of 6 bushels of bones, and 3 to 4 cwt. mineral phosphate, and a rather smaller application for white turnips, all slightly reduced if farmyard manure can be spared.

The ordinary plough of the district is used for ridging, but with the addition of a small breast bolted to the near side, and very good work was accomplished by this simple plan.

The turnip land was altogether in satisfactory order, and will no doubt produce its full quota this season.

A piece of sainfoin, a plant quite at home on the thin chalk, proves most useful in keeping health amongst the lambs in the autumn, than which nothing can be better at that critical time.

Having so little grass, great reliance is placed in the rota-

tion seeds, pains being taken in composing the different mixtures, also in combining with others in the locality in purchasing seed wholesale, saving thereby a good round sum per annum.

Different districts and modes of farming no doubt require different seeds to be sown for grazing, but such great consideration having been given by Mr. Staveley to this subject, it will, I hope, prove useful to add the list of these as below.

For two or three years' grazing with sheep (per acre):—

$\frac{2}{3}$ bushel Italian and perennial rye-grass.	2 lb. Alsike.
2 lb. Rough cocksfoot.	3 lb. White clover.
2 lb. Timothy.	3 lb. Trefoil.
3 lb. Red clover.	1 lb. Parsley.
2 lb. Cow-grass.	1 lb. Rib-grass.

Then, for one year, where wheat is not to be sown after, rye-grass is used, to the extent of one quarter per acre, and—

$5\frac{1}{2}$ lb. White clover.	$1\frac{1}{2}$ lb. Rib-grass.
2 lb. Red clover.	4 lb. Italian rye-grass.
2 lb. Alsike.	1 lb. Rough cocksfoot.
$5\frac{1}{2}$ lb. Trefoil.	1 lb. Timothy.
$1\frac{1}{2}$ lb. Parsley.	$\frac{1}{10}$ bushel of rye.

Two mixtures are given for grazing seeds when to be followed by wheat. These are, per acre:—

No. 1.	No. 2.
6 lb. White clover.	7 lb. White clover.
6 lb. Red clover.	$3\frac{1}{2}$ lb. Red clover.
10 lb. Trefoil.	$1\frac{3}{4}$ lb. Alsike.
1 lb. Parsley.	11 lb. Trefoil.
1 lb. Rib-grass.	$1\frac{3}{4}$ lb. Parsley.
—	$1\frac{3}{4}$ lb. Rib-grass.
24 lb.	—
	26 $\frac{3}{4}$ lb.

Very nice close-bottomed leys were the result on the whole farm, and a large number of sheep were being supported by them.

An account is kept of the cropping of every field since 1877, when the farm was taken; but for the year 1891 the following acreages are given:—

Wheat, 115 acres.	Rape, 20 acres.
Barley, 122 acres.	Tares, 3 acres.
Oats, 143 acres.	Seeds, 181 acres.
Turnips, &c., 162 acres.	Sainfoin, 16 acres.
Mangel, 3 acres.	Grass, 85 acres.

The whole of the arable land is nicely managed, the corn being well weeded and nearly clean, the turnip fallows in good order, and altogether, with the large fields surrounded by small

trim hedges, the farm presented a very creditable appearance on our June visit.

The serious drop in the value of corn mentioned above has naturally caused Mr. Staveley to look more to stock, especially sheep, and the returns sent to Government in June 1890 are larger by nearly 200 than those for 1877. The very detailed list of live stock handed in showed 34 horses, 20 of which worked the farm, 88 cattle, 766 sheep, and 62 pigs.

The land not being suitable, Shire horses are not bred on the farm, but one or two useful horses have to be bought now and then, to supply the wear and tear caused by the working of so much arable land. A small stud of Hackneys, eligible for or entered in the stud-book, is, however, being commenced, and a hunter at a good round sum is occasionally sold.

The cattle are most of them bred on the place, a very useful bull being kept. *Eden Butterfly*, the one now at the head of the herd, was purchased of Sir R. G. Musgrave, Bart., Eden Hall, Cumberland, and its dam gave 24 quarts of milk in one day.

The bullocks are fed in the yards, presumably more to supply good manure than much profit, but some very useful ones were disposed of fat during our visit.

The cows are kept for dairy and breeding purposes, and when dry run in the yards, receiving a little cotton-cake, turnips, chopped oat-straw, and oat-straw *ad lib.* The new milk is given to the calves for about 14 days, then gradually reduced to old with the addition of a milk substitute, the endeavour afterwards being to keep them in good condition by a few roots, ground oats, union cake, and a little linseed dust. They are not allowed to go out during the first summer.

Sheep, more than cattle, on a thin Wold farm naturally adapt themselves to the situation, and Mr. Staveley keeps them in large numbers, the bulk being what he terms Improved Leicesters, a larger Leicester than the old-fashioned breed. A small flock of Oxford Downs has been commenced, sheep of the very best blood only being purchased or used, a two-shear ram from Mr. Treadwell's flock running with the ewes last season.

On our June visit, nineteen very useful rams were progressing for sale in the autumn, and the 50 ewes had by their sides 80 very forward lambs.

Nearly 300 ewes were running on the seed pastures. They were of the Leicester breed, and had with them a very heavy fall of lambs, which were not quite in such good condition as their mothers, the latter being almost too fat, if anything. Half a pound of cotton-cake per ewe is allowed, and the lambs, when taken off, get a mixture of cake and oats.

The feeding hogs on the turnips in winter, which are fingered after December 1, are allowed not often more than  $\frac{1}{2}$  lb. per head, consisting of  $\frac{1}{4}$  lb. linseed or mixed cake, and  $\frac{1}{4}$  lb. corn, maize being preferred when cheap enough.

Some of the old Leicester ewes are put to an Oxford ram, and the nice mutton from the cross is much sought after by the butchers.

A detailed list of the sheep of various breeds need not be given, but it will suffice to say that on January 1 there were 776 altogether on the turnips.

A few customs of the East Riding might be interesting, and would, no doubt, be noticed by a stranger. For instance, the waggoners all have saddles, and it looked curious to see a Cambridge roller being driven by a man up in the saddle, though I will admit he was getting over the ground at a smart pace.

At the station a neighbouring farmer had sent four pole waggons with four horses each for some trucks of ashes or refuse from the towns, and it was a grand spectacle to see the four waggoners mount their saddles and drive off.

The foremen on these Wold farms (and Mr. Staveley has two) board the horsemen in their houses, and sometimes a boy or two in the winter to work in the sheep-fold, receiving 7s. 6d. per head per week, with 1s. extra for each man in harvest. A garden is found, and 2l. allowance for fruit and vegetables, 2l. for stable lights, 11l. for ale at threshing and harvest, and the produce of two cows. In one case the wife has 20l. for managing the dairy, &c. She quite understood when granular form, butter workers, and thermometers were mentioned. Payments are also made for rearing poultry and for gathering eggs. Bedding and requisites for the men are found, including cooking utensils, plates, dishes, &c.

Mrs. Barron, at the village farm, is a typical example of an East Riding foreman's wife, and by invitation the large kitchen was examined, with its long table, on which the men have their meals.

The day is commenced at 5.45 with breakfast, consisting of beef and bread and boiled milk, followed by fruit pies, apple or prune, in the absence of which preserves are used.

The dinner-hour varies, according as one yoke or two are worked with the horses, but beef, preserve tart, soup, suet pudding, with roast beef on Sundays, are given, and if one yoke is worked the men take out a small bit of food for luncheon at 11 A.M. Supper is at 6.30, and is similar to breakfast.

Meat three times a day, and plenty of it, is what the stalwart men of the East Riding of Yorkshire are reared upon, and few finer and stronger are seen anywhere.

The thatchers make a very neat finish of the round corn stacks, called pikes. neither string nor pegs being used, but thin straw ropes are worked and twisted in with the sheaves underneath.

The labour bill amounts to about 1,000*l.* per annum, Mr. Staveley and his men being to all appearances on the best footing with one another, as he continually spoke well of them.

A certain income is made by the poultry, eggs and butter, not to mention a few game-fowls, which are said to be worth large sums, and have won prizes innumerable.

A very systematic record is kept of all the cropping, besides complete flock-books, with the breeding of all the Oxford Downs noted, whilst every item could be referred to at once when required for the Judges' information. Altogether they had great pleasure, and no hesitation, in awarding the Second Prize to Mr. Staveley on this typical Wold farm.

#### CLASS I.—THIRD PRIZE FARM,

*Occupied by Mr. James Townend, Newton Farm, Doncaster.*

This is a very nice farm near Doncaster, being only about one mile from the station; indeed, as the crow flies, the back of the railway works is merely a stone's throw from the grazing land next the river. Being so near a town, advantage is taken of the supply of stable manure, also of the extra hands, which appear to be plentiful.

The farm consists of 282 acres, of which 180 are arable and 102 grass, and is held under Lady Watson Coply, Sprotbro Hall, at a rental of 378*l.* Since entering in 1882, very great improvements have been made, Mr. Townend seeming to despise the small enclosures into which the place was divided; enormous lengths of old hedges have been stubbed, and new ones planted when required, thus altering the size and shape of the fields entirely. Trees also in large numbers, some of them of great weight, have been felled, the local timber-merchant to whom the landlady sold the wood being employed to load the enormous roots on to his waggons and throw them into a large pit out of the way.

Whether all this be judicious or not, considering that no compensation would be allowed on leaving, yet the tenant has the satisfaction of seeing a great improvement made, and if he be content to spend the money, his landlady should be more so.

The new quick-thorn hedges were in splendid order, and had almost grown up sufficiently to make a sheep fence.





of pasture is to be seen on this low land, and proves useful, as it runs right up to the yards, and the cows and horses can be turned out by opening the gate.

The next square consists of beautifully cool loamy land, admirably fitted for growing potatoes as well as turnips, wheat, barley, and seeds, and if a little more pains had been taken in weeding the spring corn (perhaps 5*l.* would have done it) the Judges would have thought this a very successfully farmed portion of the occupation.

The farther and hilly end is farmed differently, no potatoes being grown as the limestone rock is near. Evidently the tenant does not think this his best land, as not quite such pains are taken in the cultivation, with the result that one or two fields were very foul.

The corn crops at our June visit were looking very well, the wheat after the potatoes promising a good yield, being stiff in the straw, as is usual on such land after that crop.

A portion of seeds had been broken up on the hill, in which the clovers had missed, and was sown with wheat in February. Mr. Townend seemed to think it the best piece in the district; an application of soot had certainly given it a good colour, and it looked well. The oats adjoining were a fair piece, and the turnip land in the next field had been well worked, but was not sown on June 18.

Altogether the crops on this hilly part looked fairly well, but Mr. Townend had not used such energy as on the square of land nearer home, in order to make the twitch, &c., conspicuous by its absence.

The barleys on the lower portion were magnificent pieces, sown after the sheep had eaten the swedes, and our only fear was that the crop would be laid if a wet period followed.

The potato land was in very good order. It had been nicely ridged and was very clean, the plants coming up with vigour and strength. Although there were few weeds, the hoes were being used round every set, loosening the soil, an operation which always seems to make the tops grow apace.

Plenty of manure had been applied, and there was every appearance of a good profit on this somewhat risky venture; for instance, Mr. Townend happened to sell his crop at 50*s.* per ton put on rails, and during the winter 120*s.* might have been made. The year previous trade was bad, and thousands of tons were sold at 25*s.* or less, whereas luckily on this farm they were cleared early at 54*s.*

The seeds grazed by the ewes and lambs were a mattress of white clover, 14 lb. being sown, with 2 lb. trefoil, 2 lb. cow-

grass, and a small quantity of rye-grass. A nice plant was also showing amongst the spring corn.

The grass land near the house, before mentioned, is most useful and of good quality, no doubt much of it being a deposit left by the overflow of the river Don in past generations; but vast sums have been spent here by modern engineers, and to a great extent have prevented the floods, which until a few years ago rendered some of the streets of Doncaster impassable, and periodically covered miles of country just beyond the Great North Road.

Besides a small home paddock or two, a large grass field adjoins Cusworth—about 38 acres, in which were running 42 steers and heifers, of various sorts and sizes, nearly all of which had been bred or reared on the farm. Great improvement had been made here, by tearing up old fences, putting drains in, and sowing down five acres with two quarters Penistone hay seeds; and seven pounds mixed clover seeds per acre with rape. After five years this portion compared favourably with the old grass.

The live stock in January consisted of 18 horses, 58 cattle; 354 sheep, and 34 pigs.

Useful horses were working the farm, and two are sold each year if possible.

The cattle, which were not a very even lot, were being kept in store condition, ready to turn out in summer, calves being bred and reared in very nice pens not too far from the kitchen, and thus convenient for the disposal of the old milk.

The sheep are many of them bought, seventy-seven Lincoln ewes only being lambed on the place, and these with others were running in the seeds. They were a good lot of sheep altogether, but numbers both of the ewes and lambs being lame, their appearance was a little spoiled. In spring some remarkably good hogs were being sold off the swedes, and were many of them of great weight.

Mrs. Townend ably assists with the rearing of the calves, and with the dairy; but very low prices are made for the butter. A little milk is sold at elevenpence per imperial gallon on Sundays to accommodate a neighbour, and it was thought, being so near Doncaster, and having good grass, that a great addition might be made to the income by running milk into the town every day.

Mr. Townend is a cattle dealer as well as a farmer, attending Wakefield market every Wednesday, and the profits on this part of the business have no doubt been laid out for some years in the great improvements made on the farm, especially the better portion, to which the tenant seems to give his chief attention.

## CLASS I. COMMENDED FARM,

*Occupied by Mr. Smith E. Parkin, Melton Brand, near Doncaster.*

This is another of the farms easily reached from Doncaster, and is on the limestone formation. It is a very nice occupation, the fields being fairly even in size and quality, but the grass land, except a paddock or two, is a mile or more away, and not of very first-rate quality when reached.

Mr. Parkin's farm pupils, who rightly have to do a little work when at Melton Brand, were pleasantly occupied in taking the young cattle backwards and forwards, at the April visit, until they got hardened and could stay out. Another pupil was driving the engine when sawing rails, &c., for fencing the fields.

The pupils, perhaps, learn more farming here than at many places, owing to the system on which they are taken being that of paying more the first year, less the second, and much less the third, in proportion to the amount of work they do.

The farm consists of 430 acres in all, of which 287 are arable and 143 grass. It is held under Mr. Montagu, Melton Park, and has only been in the hands of the present tenant about five years.

The buildings were in good order, their usefulness being greatly enhanced by a large covered yard, put up by the landlord, who was also fixing a set of new gates and posts in the fields where required.

A modified four-course system of farming is practised, but about thirty acres of potatoes are planted instead of wheat on the seeds, which necessarily causes other slight deviations.

Nice pieces of swedes were being eaten on the land in the winter, and had 12 loads of manure with 5 cwt. of dissolved bones, said to be bones and acid only, the white turnips being treated with mineral phosphate instead.

In the June visit, on the first day of the Royal Show, the swedes were nicely up, but, in common with much of this limestone land, a very nasty crust had formed on the ridges, not only at Melton but generally in the district.

On some of the farms a roller had been run on the ridges, doing a little good; but Mr. Parkin has one of the Royal Prize Turnip Drills, made by Yates, of Doncaster, who has so altered the frame that side hoes can be attached behind, not only rising and falling with the rollers, but following any deviation in the straightness of the ridges.

The illustration of the drill (fig. 2) on the following page

will better explain how the work is done. Not only was the crust broken by the weight of the rollers, which can be adjusted, but the patent side hoes had shaved the soil and weed off much more closely than in the drawing, so closely indeed that many plants appeared as if cut up, but on further examination they were found to be intact. For those who sow many turnips on the ridges, this is a most valuable yet simple implement.

A good breadth of potatoes is usually planted, perhaps thirty acres, after the seeds; one ton per acre of Magnums is generally

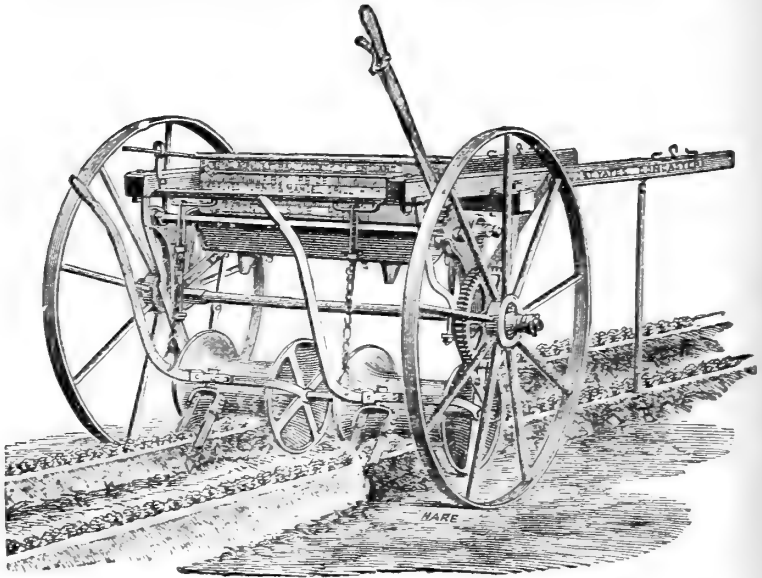

FIG. 2.

set, but a few Bruce and Reading Giants are being tried as well this year.

Mr. Parkin puts on 20 two-horse loads from the fold-yard, also 7 cwt. per acre of potato manure, and 3 tons of shoddy, which is largely used and much liked on the farm. Men were busily engaged in hoeing round the plants, but it was feared, unless wonderful weather ensued, that the land could not be made clean. A London dealer had, unfortunately for the tenant, bought the last season's crop by the acre, and as potatoes rose fully 100 per cent. he would no doubt secure large profits.

The list of stock returned included twenty horses, one being a Shire stallion, bred by the Earl of Ellesmere, by which several mares were in foal.

Eighty-nine head of cattle of all ages were in the yards, some being tied up to feed. Others in the covered yard were in rather poor condition, as their food had been reduced after the loss of several by black leg.

The ewes and lambs ran on the seeds in the summer, and, like others round Doncaster, had turned a little lame after clip day. All the male lambs are kept as rams, being highly fed, and producing great weight for the Manchester market in spring. Some of the gimmers had been valued and sent to another farm, which is held in partnership with a late pupil.

Mrs. Parkin and her daughters take great interest in the dairy, priding themselves on their production of butter, and, with the poultry and eggs, add a good round sum to the treasury.

#### CLASS I.

The remaining farm in this class is occupied by Mr. J. Lodge, of Robin Hood's Wall, near Doncaster, under Mr. Yarborough, of Camps Mount, who also owns the second-prize farm in Class II. The total acreage is 331 acres, 72 being grass, and as the occupation is similarly worked to the two other farms in this class near Doncaster, only very few remarks on it will be necessary.

The swedes, as on another competing farm adjoining, were nearly all sound, which we also attribute to the magnesian limestone. Twenty acres of potatoes are grown, and are well dunged, receiving  $4\frac{1}{2}$  cwt. guano, or 7 to 8 cwt. blood and bone manure. Mr. Lodge luckily kept his potatoes until the spring, making in the end a good figure per acre. The mangel was a very nice plant, and although badly requiring singling, was the best piece seen in the whole round.

#### CLASS II.—FIRST PRIZE FARM,

*Occupied by Mr. Andrew Merryweather, Whiston, Rotherham.*

This farm consists of 114 acres, of which 88 are arable and the remainder grass. Two arable fields were not eligible for competition, having been only one year in occupation.

The land is fairly light. Turnips and sheep, with barley as the chief cereal, are the staple products of the farm, which has a subsoil of gritstone, and clay in places.

No sheep are bred on the place, but are bought at the fairs. In this instance 122 hogs came from the York fortnightly market, costing 39s. each, and being a cross between a Scotch ewe and Leicester ram, the produce being again crossed with the Wensleydale, and these are called "Mugs." They were

doing well on swedes, with  $\frac{1}{3}$  lb. linseed cake and cut clover. Mr. Merryweather feeds them off as fast as he can, and then buys others in the spring for the seeds, which when ready are treated likewise.

About 33 head of cattle were kept in the yards, consisting of a very useful Shorthorn bull, 14 cows or heifers in milk or in calf, 4 bullocks feeding, and 15 others, including several calves which were being reared at the house upon the old milk.

Butter is usually made and sold in the neighbourhood, a little new milk being sometimes fetched from the door at three-pence per quart.

Five horses are kept for the farm, including one filly two years old.

In the stackyard a very good Dutch barn, 84 feet by 30 feet, had been erected by the landlord at a cost of about 130*l.*, the tenant agreeing to pay interest at 6 per cent.

The fallow land was all in very good order, and on one piece, which was most beautifully ridged, a very good piece of swedes and two acres of mangel were waiting to be singled.

Wheat, except one corner of a field which had turned out with the frost, looked very well. The oats and barley had evidently suffered from the long-continued dry weather, and would no doubt have been better with a more genial spring.

A good crop of clover and rye-grass would be ready to mow in a short time. It is customary to sow a little nitrate of soda in one corner of the field, which is mown every day for use in the yards, the rye-grass being much increased thereby, whilst the clover certainly looked darker for it, and the tenant was sure of a heavier cut. At any rate a great weight was grown per acre, and considerably scoured some young beasts in the yard, perhaps from the over succulence produced by the nitrate of soda.

Large quantities of manure are fetched from Rotherham, and used on the swedes and mangel at the rate of 12 to 14 loads per acre, together with 3 cwt. bone dust and 2 cwt. of mineral superphosphate. Linseed and cotton-cake were used to the extent of 150*l.*-worth in the year 1890-91, also about 300 bushels of ground corn of various sorts.

Two pieces of good permanent grass are, one of them near home, used to turn the cows and heifers into, whilst the other at a little distance has a few two-year-old bullocks grazing, as well as the horses at night.

More than 20 acres of the stronger portion of the farm have been at different periods during the last six years sown with permanent grass seeds, some with mixtures supplied by the

great seed establishments, and others with one quarter of Penistone hay seed and a few clovers. Very particular attention was given to try to determine which pieces were the best, but after walking them over at the three visits it was difficult to decide, although the seeds in one case had cost perhaps nearly double those in the other.

In the course of years the farm will be much improved by the addition of these new grass fields, especially as considerable amounts of good manure are put on every other year, as well as dissolved bones and mineral superphosphate sometimes.

Most admirable sets of accounts are kept, and Mr. Merryweather, being a valuer as well as a farmer, goes over every field separately, putting himself in the position as if he were leaving. A few items which he kindly allowed to be taken from his notebook may be interesting.

Particulars were shown of 9 acres 2 roods 22 poles of swedes, mangel, white turnips, and cabbages, all well manured, being charged against the incoming tenant at 104*l.* 9*s.* 1*d.*, deductions, however, being allowed thus: one acre white turnips drawn, 3*l.*; two acres mangel drawn, 8*l.*; two roods cabbages eaten on, 1*l.*, and 5 acres 3 roods 20 poles swedes half drawn and half eaten on, 17*l.* 12*s.* 6*d.*, making altogether 29*l.* 12*s.* 6*d.*, leaving nearly 75*l.*, a stiff sum of roughly 8*l.* per acre to pay for that field on entry. Instead of the protracted valuations of following crop the condition allowances prevailing around Sheffield and Rotherham are much more simple, up to 60*s.* per acre being awarded according to the state of the field, in addition to charges for seed, labour, &c.

Permanent grass, if properly laid down, commences at 60*s.* per acre at the end of the first or second year, increasing 5*s.* per acre per annum up to 5*l.*, in addition to manures on the three years principle if pastured, and two years if mown.

## CLASS II.—SECOND PRIZE FARM,

*Occupied by Mr. John Stanley, Campsall, Doncaster.*

The village of Campsall is most pleasantly situated six or seven miles north of Doncaster. The landlord of this farm, Mr. G. B. C. Yarborough, who resides here at Camps Mount, takes great and active interest in agriculture, especially assisting at Doncaster with the recent Show, and with the Local Shire Horse Society; whilst anything that will benefit his tenants and neighbours is sure to have his name associated with it.

This holding, which consists of 125 acres arable and 34 acres pasture, is of good red soil, overlying the magnesian lime-

stone, and is well adapted for growing turnips and barley, also potatoes of very good quality. The fields, all of suitable size, are in a ring fence, bounded on all sides by a road, and the hedges uniform, with but few gaps. A good rent is paid, especially considering the heavy payments customary on entering a farm in this neighbourhood.

Mr. Stanley, being a carpenter by trade, has worked his way up to the position he now holds. After running a threshing machine for hire a few years he was enabled to take this farm.

The very small sum of 35*l.* was paid at the commencement, but that was owing to the exceedingly bad condition, and cross cropping had been practised. Had everything been well done, perhaps double that amount might have been decided upon by the valuers, and the competitor thinks this would have been to his advantage, as he could have grown good crops at once.

Very tidy and compact buildings are situated at one end of this farm in the village, containing sufficient accommodation for the stock, as well as a new set of horse gear and chaff-cutter. The landlord a short time ago put up a large covered yard, the end of which adjoins the grass paddock, making a convenient place for young stock to run in and out of during the summer.

A four-course system of farming is with slight variation followed on the land: (1) turnips or potatoes; (2) barley; (3) seeds grazed and mown, or pease; (4) wheat and oats. The inclusion of a pea crop to a small extent in the rotation is hazardous, but sometimes exceedingly remunerative. In a good season, if the pods are ready just when others are, the returns of the commission men are the reverse of pleasant; on the other hand, if the crop can be thrown on the market either very early or very late in the season, then a satisfactory price is obtained, and at such times buyers come round and bid for the lot by the acre, and pull them as well.

Eight acres last season yielded 76 bags per acre at 6*s.* per bag, which amounts to a good sum. This year the haul is thin in one portion, so a passing buyer has only bid 10*l.* per acre; but Mr. Stanley is holding out, as he can market them himself if the price be not advanced. Labour is very plentiful for the picking, women coming from all the district round, and making very good wages at the rate of one penny per peck of nine pounds.

A little fresh seed had been purchased for one field, showing great superiority in the crop for the extra expense, although the same variety, Laxton's Supreme.

During the picking, men are following closely behind, heaping



the haulm, which if in good order makes good stuff for the cattle in winter. This crop being got off early, an opportunity is afforded for cleaning the land ready for sowing with wheat.

In the winter, about 40 ewes are kept on the turnips, and late in June 60 lambs were running with them on the seeds, which afforded good pasture.

The lambs were an even lot, but the ewes were most of them exceedingly fat. They looked in much better condition than the lambs.

This fact was noticed on many of the farms inspected, and may be a peculiarity of the season. My colleague, however, thought the reason was letting the ewes and lambs feed together, instead of allowing the lambs to run forward so as to get the best of the feed, and the ewes following.

A large quantity of the "Fleshings" manure previously mentioned (page 549) was spread over the whole of the fallow land, some 113 tons being purchased this year, costing about 13s. per ton at the nearest station.

Besides this, 10 loads of manure are put into the ridges for swedes, and 7 tons for white turnips, 5 cwt. of bone manure, costing 6l. 15s. per ton, being sown with the seed.

The Judges were much struck with the keeping qualities of the swedes on this and the adjoining farm, for although every other competitor complained of damage done by the frost, yet here the exception was to find one that was not sound. The previous treatment was considered, but as field after field, although tilled differently, showed power to resist frost, the cause was put down to the magnesian limestone on which this land rests; at any rate, Mr. Stanley declares he will never store his swedes, except a certain proportion for the cattle in the yards.

The potato land receives, besides 20 one-horse loads of dung, from 5 to 6 cwt. of bone manure.

The potatoes, mangel, and swedes were showing fairly well in June, but the rains and sun together had so operated that a very nasty crust had formed on the land, which sadly needed breaking both by horse and hand.

Nice pieces of wheat and oats were seen, the latter being sown on seed land, which in the winter was being most beautifully ploughed and pressed.

The barley on some of the turnip land did not look so well as one would expect, being yellow and unkind, and perhaps a victim of the ungenial spring.

The corn had been weeded once, and was going to be looked over again, as that persistent weed the ketlock (charlock) was showing itself afresh.

## CLASS III.—FIRST PRIZE FARM,

*Occupied by Mr. T. D. Strickland, Carlton Miniott, Thirsk.*

The village of Carlton Miniott, in and around which lies the farm in the occupation of Mr. Strickland, is two miles from Thirsk station, and equally near the very good weekly auction of fat cattle, sheep, &c. These very convenient adjuncts are well taken advantage of by this competitor, as he not only sells a very large quantity of fat beef and mutton at the mart, but—as will be seen subsequently—he is constantly using the station to export specimens of his pedigree pigs to foreign lands, as well as to friends nearer home.

On our arrival at 8.25 a.m., we found the tenant himself waiting, as promised, to drive us to the buildings and the different fields, which might with profit be situated more closely together, and nearer to the homestead.

The first glance at the premises showed that “trim and tidy” was the rule on this part of the holding. Many substantial and permanent improvements also revealed themselves, and had been done at the sole cost of the tenant.

Conspicuous among the latter was an excellent covered yard—77 feet by 54 feet—the roof of which was made of inch boards, with grooves near the edges, as described in the Journal, (Vol. I., 3rd series, 1890, page 479), and supported by thick larch posts. The sides of the yard were, in our opinion, too open, which fact was proved, as during the March winds movable wooden shutters had been added, greatly increasing the comfort of the stock, whilst the interspacing of the roofing boards provided ample ventilation. The total expense incurred in covering this yard, including the bricklayer, joiner, and plumber, was 77*l.* 10*s.*; the tenant having an agreement with his landlord that an allowance would be made at the expiration of the tenancy.

An implement shed of ample dimensions had been erected in the stackyard, the gates and fences about which and in the fields were of excellent description and well painted.

Two other small sets of buildings very near to the station were used principally for the accommodation of the large number of pigs of various breeds.

The home paddocks, consisting of about 10 acres, are not so good perhaps as they will be, having only been laid down nine or ten years by a former tenant. They, however, get each year a liberal allowance of compost, consisting of gas lime, road scrapings, &c., also in the autumn 7 cwt. per acre of basic

slag, and this spring 3 cwt. of grass manure. The phosphate in the slag is said to have visibly added to the plant of clover.

A somewhat excessive quantity of manure is used. The mangel received per acre, in February, 7 cwt. salt, and later 30 loads of manure, whilst  $2\frac{1}{2}$  cwt. of dissolved bones were drilled with the seed.  $1\frac{1}{2}$  cwt. of nitrate of soda will be sown at two periods after singling.

For the swedes 20 loads of manure and 3 cwt. of special dissolved bones were used. A large tonnage of roots should be grown with these dressings, and even then they will cost a high price per ton.

The land being rather light, it is not considered profitable to grow wheat, so none is sown.

Except in one field, very good pastures of seeds were being grazed by sheep, and a few steers; the latter for feeding in the covered yard next winter.

Seven pounds of white clover, 3 of red, 1 of cow-grass, 2 of alsike, and 2 of Italian rye-grass, had been used per acre, and dressed this spring with 2 cwt. dissolved bones and 1 cwt. nitrate of soda. The latter would no doubt flush the rye-grass, but would be of questionable utility for the clover. Similar quantities have been sown again this spring, and a nice plant is to be seen amongst the corn.

Without giving the number of stock at each visit, it may be said that, on June 15, Mr. Strickland had 4 useful horses for the farm, besides 3 others and a foal, 6 two-year-old bullocks, 3 fifteen-month heifers, 3 cows, 121 feeding sheep, 20 Wensleydale ewes with 30 lambs, 3 rams, and 138 pigs.

At the first visit, a dozen useful bullocks were having one cake per day in the covered yard, with meal added and roots; these have all been sold at about 21*l.* each. The hogs feeding on the swedes had, with the help of 1 lb. of mixed cake, been nearly all sold by auction, twenty per week, at 48*s.* to 54*s.* each clipped. These sheep were bought at York, being a cross from a Bamshire<sup>1</sup> ewe and an Oxford or Hampshire ram, as those are at present on the seeds.

A small flock of 20 pure Wensleydale ewes are now running with 30 lambs, and it is intended to keep these pure by the addition of the best blood. A ready sale for the rams in the autumn is expected.

As many a fallen foe in the arena of the showyard knows

---

<sup>1</sup> Bamshire sheep are described in the *Journal*, Vol. XIX., Second Series, 1883, page 513.

to his cost, Mr. Strickland's *pièce de résistance* is the pig, and a great portion of the above mixed farming, and very many of the buildings, are subservient to the raising of pedigree pigs for sale for stock purposes. These are constantly being sent abroad to Germany, Sweden, France, Canada, and South America, besides our own country.

During our visits we usually saw something approaching 140 pigs of all kinds, consisting of 30 Large White sows, 20 Middle White breed, and 10 Berkshires, 6 boars being kept of the best kind that can be got, one just purchased, *Thirsk Champion 20th*, costing 21*l.* 7*s.* 6*d.* at ten months old.

None of the pigs are sold fat, but merely in store condition; six were going in June to Germany at 6 guineas each; indeed, although the Judges thought rather too many were kept, Mr. Strickland manages to sell nearly all as fast as they can be grown to a breeding age.

Prizes altogether, but chiefly for pigs, have been won since 1874 to the value of 4,326*l.*, the sales of pigs alone in 1889 amounting to 1,363*l.* 1*s.* 11*d.*, and in 1890 to 1,980*l.*

### CLASS III.—SECOND PRIZE FARM,

*Occupied by Mr. William Walsh, Gilstead, near Bingley.*

This tenant, who has been on his holding about twenty years, renting it principally from Mr. F. S. Powell, M.P., of Horton Hall, Bradford, makes milk his chief source of income, and rightly so, as living only one mile from Bingley, or less, there appears to be no difficulty in finding a good wholesale customer, who fetches it twice daily from the door, at eight-pence per gallon. Thus, railway rates, terminals, and the chance of missing the early morning milk train, are not troublesome points for the consideration of Mr. Walsh.

About 30 useful cows are generally kept, 24 of them in milk; the rest are either being dried off previous to calving, or are a small lot of purchased ones, which seem to be continually coming on to the farm, firstly to keep up the guarantee of 40 gallons per day, and secondly to turn an honest penny by the sale of a good one now and then at a profit for the few weeks' keep.

Two had thus been sold on our third visit for 27*l.* and 23*l.* 10*s.*, and a very good type of animal they were, especially the former; a few such cows would improve many a herd.

A good Shorthorn bull is kept, and the present one has shown his quality by taking a third prize at the recent Otley show,

Very liberal rations are given to force the supply of milk, both summer and winter, this being necessitated by the large number of stock of all kinds. When the cows are out at grass (at the rate of one per acre) food is added as follows:  $\frac{1}{2}$  bushel grains, 7 lb. bean or pea meal, and, early in spring to prevent looseness,  $2\frac{1}{2}$  lb. cotton cake per head.

In winter, besides long hay *ad libitum* in the racks, six or eight good swedes are given three times per day, whole; also  $\frac{3}{4}$  bushel grains, 7 lb. bean or pea meal, and  $2\frac{1}{2}$  lb. linseed, cotton, or a well-known mixed cake, the latter being varied according to the yield of milk.

A small quantity of locust meal is purchased as a condiment for an ailing cow when required. Milk is consumed in larger quantities on certain days of the week, as much is required to make bread, and good bread is made in almost every home around Bingley, new milk being greatly used, not so much in preference to old, but that the latter cannot be obtained. Mr. Walsh's daughter was cross-questioned upon this interesting point, with the result that Bingley and its neighbourhood were considered a good field for the sale of separated milk, which, as is proved very largely in Scotland, makes good bread.

The sheep kept by Mr. Walsh upon his farm were certainly a curiosity, if nothing else, to unaccustomed eyes, the barns being divided into pens, and occupied by great old Lonk and Leicester rams, and a few gimmers of the latter breed. Out on the pastures 42 ewes were running with 59 lambs, all cross bred in some way or other, and being pushed on with the help of linseed cake, pease, and split maize, all being expected to be sold as fat lamb.

Eight prizes had been taken at the Otley show for sheep; indeed, a clothes-basketful of cards was on view, a few special Windsor ones hanging on the walls.

Nearly all the grass land on the farm has been laid down during the present tenure, with 8 to 12 bushels of Penistone hay seed, and 15 lb. of mixed clover per acre, then liberally manured by the use of 50 or 60 tons of sud-cake manure per annum; also on some of the fields 4 tons of lime per acre at intervals of six or seven years. This and the large quantity of purchased foods combine to much improve the new grass, which had a nice bottom, and was full of clover.

The four-course system is followed on the arable land, oats being grown after the seeds, and not wheat. Swedes, to draw off, entirely occupy the fallows, manured with heavy dressings fetched  $5\frac{1}{2}$  miles from the stables of Bradford, 2s. 6d. per cart

being paid, and as many as 200 loads used in a season. No artificial manures of any kind are purchased.

Mr. Walsh is gradually getting the larger portion of the farm down to grass, twenty-five acres only, or one-third, being left as arable. It is composed of very small fields, scattered around the village and on Gilstead Moor, a very objectionable feature in one of them consisting of three shafts for the raising of building and flag stones—very profitable, perhaps, for the landlord, but spoiling the field for working.

A very good piece of mixed seeds, nearly ready for mowing, was seen. Some of this is occasionally sold, making with a portion of the straw 150*l.*

The oats were not looking too well, having grubbed, and a portion having been resown with tares. Another part, evidently in need of draining, was thus a more easy prey to the severe late frosts of last spring.

As only a very small portion of the corn grown is sold, being used for the cows and other stock, with the addition of very large quantities of purchased foods, this competitor curiously enough complains of the recent rise in the price of cereals, instead of rejoicing as we on our corn farms do. But it is quite natural, as 10*l.* to 12*l.* per week is often spent in hand foods, the rise on which more than represents any advantage accruing from the sale of a few oats.

### CLASS III.—THIRD PRIZE FARM,

*Occupied by Messrs. J. & W. Hinchcliff, Lady Oak Farm, Emley, Wakefield.*

The two brothers who occupy this rather strong, ungenial farm, live at Skelmanthorpe, a few miles away, but seem to take great interest in agriculture, although they have a tallow-chandlers' business, which occupies most of their time.

Like the Second Prize Farm in this class, nearly the whole of the land is given up to the production of milk, and although fifty-four acres are returned as arable and twenty-eight as grass, yet many of the fields have been and are sown down with permanent grass seeds, with a view, if a good plant be obtained, of remaining so.

A minute examination was made of these new grass fields, in different stages, and sown with different seeds. One on entering the farm in 1885 was simply seeds, being lightly resown with a fresh mixture well harrowed in; a fair plant is now, after six or seven years, still to be seen.

Other pieces were laid down with 2 qrs. of Penistone hay-

seeds, 4 lb. red clover, 4 lb. white, 4 lb. alsike, 3 lb. cow-grass, 1 lb. rib-grass, 1 lb. timothy,  $\frac{1}{2}$  bushel perennial rye-grass.

A further field had a portion as above, then a seed-merchant's own prescription, another portion having a mixture applied as below, and, although grazed the same as the others, it seemed by far the best piece.

1 lb. Red clover.	10 lb. Cocksfoot.
3 lb. White clover.	4 lb. Meadow fescue.
3 lb. Alsike.	2 lb. Crested dogstail.
2 lb. Trefoil.	2 lb. Meadow foxtail.
1 lb. Rib-grass.	3 lb. Tall fescue.
2 lb. Timothy.	$\frac{1}{2}$ lb. Yarrow.

Another farm of 100 acres adjoining, and under the same landlord, has been taken this spring, and containing as it does soil more suitable for growing turnips, nearly the whole of the Lady Oak occupation will be left down in grass, which will be far better than attempting to grow roots, as at the best it is very strong and unkind land for such purposes. The coal pits, too, on the land do not improve the value from an agricultural point of view, as the miners have footpaths in all directions, the tenants complaining that in consequence a large sum has to be expended in keeping stiles and hedges in repair.

On our first visit we found 24 cows tied in the stalls, without much straw for their comfort, peat moss litter being used to some extent. The resulting manure is taken out into a covered shed, thus preserving its qualities.

No bull is kept, as each cow as soon as purchased at market is fed not only for milk but for beef, most liberal and varied rations being supplied, consisting of 8 or 10 lb. of a well-known meal, a few turnips, brewers' grains, and chopped straw, over all of which a soup consisting of oats and creed linseed is thrown slightly warm. Large purchases are made of other foods, and given at different times as a change.

From the above it will be seen that the cows are in good condition, and as the yield of each falls to 8 or 10 pints per day it is drafted off to the butchers, and generally at a price equal to the original purchase money.

When running out on the newly-laid grass-land, a large supply of purchased foods was still given to keep up the supply of 40 gallons of milk per day, which is sent to Huddersfield at 9d. per gallon in summer and 10d. in winter, being forwarded by rail morning and evening from the station distant half a mile, the rate per gallon being one halfpenny.

The Sunday morning's milk is set up, and cream sold if possible, or it is given to the calves, a few of which are fed to consume the daily surplus milk, if any.

About 40 ewes were running on the grass-land at our first visit, but in June they and their 54 lambs were mixed with about 70 more belonging to and purchased for the new farm adjoining. The original stock was a cross between a Border Leicester and a Cheviot.

The arable land, so strong and uninviting, does not look in very good condition, the oats in some places having grubbed, so that the system followed, of cropping the land as well as possible once round and then sowing down to grass, is no doubt the best way out of the difficulty. It is easy to believe that the place has much improved during the present tenure of six years.

### CLASS III.

The remaining farm in Class III. is situated at Barmborough, near Doncaster, and is occupied by Mr. Samuel Kent, who must be much troubled by the widely scattered fields, not to speak of the strong tenacious clay soil which he has to fight against. The land was not quite so clean in some places as it should have been, although an excellent plant of swedes was just becoming ready for the hoe. Some of the corn also was a good crop.

A piece of oats and peas mixed looked like yielding plenty of grain, and if only it can be harvested in fine weather, a constant supply of oat and pea straw will be available for chopping during the winter, than which nothing can be nicer.

A very good yearling Shire colt was running in the home paddock, but Mr. Kent was not quite sure if he could get it into the stud-book.

A few cows are kept, and butter is sold; calves are reared also, but being so near a large mining population, better returns might be made by the regular supply of new milk, which seems to command a good price in the neighbourhood.

Mr. Kent by hard work makes a living on this ungrateful soil, and the Judges could only wish he had a better and more compact holding.

### CONCLUSION.

The above short account of the different farms cannot be closed without recording the thanks of the Judges to each competitor for his kindness in giving them every assistance in their pleasant if somewhat hard work, and they now know by the great hospitality they received what is meant by a real "Yorkshire welcome."

W. C. BROWN.

---



## Official Reports.

### THE COMPARATIVE FEEDING VALUES OF DECORTICATED AND UNDECORTICATED COTTON-CAKE.

*A record of feeding experiments conducted at the Society's Experimental Farm, Woburn, in the years 1888-9 and 1890-1.*

AN important question, but one upon which practical farmers are not agreed, is, whether decorticated or undecorticated cake is the better form in which to make use of the refuse cotton-seed for the purpose of feeding stock. Both, it is admitted, are valuable and economical foods, but some feeders maintain that the undecorticated or common cotton-cake is the safer and better to use, because it is free from the hardness and the indigestible lumps which too often characterise the decorticated cake, and because the husk left with it imparts a wholesome astringency to the diet. Others who have had experience of the decorticated cake are ready, on the contrary, to maintain that, if reasonable precaution be exercised, and the worst class of cake be avoided, there is no difficulty in feeding with it, and that it will amply repay the trouble and give a decidedly better result.

To aid in settling such questions is manifestly the work of an experimental farm such as that which the Society, through the generosity of the Duke of Bedford, is enabled to carry on at Woburn. The results of trials made in two different years, in the one case with Hereford cattle, in the other with Shorthorns, are now given. It may be said that the past experience at Woburn has been to show that, from the commencement in 1877 to the present time, although decorticated cotton cake has been used every year, and only the ordinary quality purchased that happened to be in the market at the time, no difficulty whatever with, or harm resulting from the use of, decorticated cotton-cake has been experienced throughout.

#### EXPERIMENT of 1888-9.

The bullocks were eight in number, all Herefords, three years old, and they cost, in October 1888, 17*l.* 9*s.* each. The specially constructed feeding-boxes, holding in all eight beasts, were used. Four

bullocks, to be fed on decorticated cake, were kept in the left-hand boxes, and the other four, to be fed with common cotton-cake, in the right-hand boxes. The bullocks were selected with care, there being only 2 lb. difference between the total weights of each set of four. The foods given to each lot were as follows:—

Left-side boxes.	Right-side boxes.
Decorticated cotton-cake.	Undecorticated cotton-cake.
Linseed-cake.	Linseed-cake.
Barley.	Barley.
Roots and hay-chaff <i>ad lib.</i>	Roots and hay-chaff <i>ad lib.</i>

Thus, the only difference between the foods was in the kind of cotton-cake used in either case. Samples of the foods were taken weekly, and the monthly portions analysed. The following table gives the average composition of the foods throughout the whole time of feeding:—

	Decorticated cotton-cake	Undecorticated cotton-cake	Linseed-cake	Barley, griddled	Hay-chaff	Roots
Moisture . . . . .	9.64	13.85	12.19	18.55	15.06	89.12
Oil . . . . .	14.82	4.63	10.95	1.91	—	—
<sup>1</sup> Albuminous compounds . . . . .	44.31	24.21	27.25	10.74	9.90	.98
Sugar, starch, digestible fibre, &c.	20.56	30.76	33.53	63.28	41.43	8.36
Woody fibre . . . . .	4.42	21.63	8.89	3.12	24.76	.85
Mineral matter (ash) . . . . .	6.25	4.92	7.19	2.40	8.85	.69
	100.00	100.00	100.00	100.00	100.00	100.00
<sup>1</sup> Containing nitrogen. . . . .	7.08	3.87	4.37	1.72	1.58	.16

By making, as was done here, all the foods alike with one exception, it enabled, as far as was possible, any difference in the final weights to be attributed to the cotton-cake, the only varying constituent. At the same time, it is undesirable in a feeding experiment to bind animals down to eat this or that particular quantity of food; therefore, while the additional or artificial foods were increased equally in both cases, the bullocks were allowed to have both roots and hay-chaff in the quantities which they would clean up well, *i.e.* practically *ad libitum*. The amounts given were, however, weighed out to them, and any not consumed at the end of the day was weighed back. The experiment lasted the somewhat long period of 145 days, *viz.* from December 20, 1888, to May 14, 1889, and was divided into three portions, at the end of each of which, *viz.*, February 20, March 28, and May 14, the beasts were weighed. They began feeding with 4 lb. of barley (griddled), 2½ lb. of linseed-cake, and 2½ lb. of either kind of cotton-cake per head daily. During the second period the barley was kept the same, the linseed-cake increased to 3 lb., as also the cotton-cake. In the final period the barley and linseed-cake were kept the same, but the cotton-cake was increased gradually until on April 14 it reached 5 lb. per head

daily. Mangel was substituted for swedes on March 28. The quantity of roots consumed throughout was, on an average, 40lb. per head daily, and of hay-chaff  $8\frac{3}{4}$  lb. to 9 lb. The water given was also weighed; more was drunk by the beasts taking decorticated cake than by the others, the relation being, in the first and second periods 35 lb. as against 25 lb., and in the third period 39 lb. as against 32 lb. daily each animal.

At the conclusion of the experiment five well-known stock-farmers of experience were invited to the farm, in order to place their estimates on the eight animals previous to their being weighed. A table of the results by the two methods, and showing how very far wrong the estimates were, is given in a paper by Mr. Albert Pell on "Weighing Live-stock" [Journal R.A.S.E., Second Series, Vol. XXV., Part II. (1889), p. 463]. The bullocks were weighed on May 14, then fasted one day and the fasted live-weights again taken. After this the beasts were slaughtered and the carcass weights recorded, all the operations being conducted by Mr. Fraser, the able manager of the experimental farm at that time.

The following table gives the live-weights of each bullock and of each set of bullocks at the commencement and at the end of the various periods of feeding, and also the respective gains obtained:—

I.—*Four Hereford Bullocks fed on Decorticated Cotton-cake with other Foods (alike in both cases).*

No.	Weights at commencement, Dec. 20, 1888	Weights on Feb. 20, 1889	Weights on March 28	Weights on May 14	Gain in live-weight in 145 days
	cwt. qr. lb.	cwt. qr. lb.	cwt. qr. lb.	cwt. qr. lb.	cwt. qr. lb.
1	9 3 26	11 3 4	12 2 12	13 1 5	3 1 7
2	10 0 22	11 3 0	12 0 22	13 0 7	2 3 13
3	9 2 12	11 0 0	11 2 10	12 2 0	2 3 16
4	9 0 0	10 1 14	11 0 12	11 1 17	2 1 17
—	38 3 4	44 3 18	47 2 0	50 1 1	11 1 25
Gain per head daily each period.		2.76 lb.	2.01 lb.	1.64 lb.	2.21 lb.

Gain per head daily during entire period, 2.21 lb.

II.—*Four Hereford Bullocks fed on Undecorticated Cotton-cake with other Foods (alike in both cases).*

5	9 0 3	10 2 23	11 0 18	12 0 4	3 0 1
6	9 3 7	11 1 17	11 3 14	12 1 14	2 2 7
7	9 3 26	10 3 12	11 1 14	12 0 4	2 0 6
8	9 3 26	11 1 7	12 0 0	12 2 10	2 2 12
—	38 3 6	44 1 3	46 1 18	49 0 4	10 0 26
Gain per head daily each period.		2.47 lb.	1.65 lb.	1.56 lb.	1.97 lb.

Gain per head daily during entire period, 1.97 lb.

The next table gives the respective fasted live-weights, and carcass weights, with other particulars relative to the sale :—

## I.—Decorticated Cotton-cake Lot.

No.	Live weights on farm, May 14			Fasted live weights in cwt. qr. lb., also in stones of 14 lb. May 15.			Loss in fasting	Carcass weights in 8 lb. stones		Percentage of carcass	Price realised at 4s. 8d. per stone dead-weight				
	cwt.	qr.	lb.	cwt.	qr.	lb.		st.	lb.		per cent.	£	s.	d.	
1	13	1	5	12	2	24=	101	10	per cent. 4·4	106	6	59·97	24	18	4
2	13	0	7	12	0	20=	97	6	6·8	104	6	61·43	24	9	0
3	12	2	0	11	3	12=	94	12	5·1	103	7	62·57	24	4	11
4	11	1	17	10	3	14=	87	0	4·6	93	7	61·66	21	17	7
—	50	1	1	47	2	14=	381	0	5·2 average	409	2	61·40 average	95	9	10

## II.—Undecorticated Cotton-cake Lot.

5	12	0	4	11	0	20=	89	6	7·1	93	0	59·42	21	14	0
6	12	1	14	11	3	0=	94	0	5·0	102	0	62·00	23	15	11
7	12	0	4	11	1	24=	91	10	4·7	98	1	61·14	22	17	10
8	12	2	10	12	0	14=	97	0	3·7	105	2	62·00	24	11	1
—	49	0	4	46	2	2=	372	2	5·1 average	398	3	61·14 average	92	18	10

Gain of Lot I. over Lot II. in carcass weight 10 7 <sup>st.</sup> <sup>lb.</sup> In money value 2 11 0  
 Gain per beast in Lot I. „ „ 2 5 <sup>3</sup>/<sub>4</sub> „ „ 0 12 9

Next are given the estimates of the carcass weights of the eight animals, as made by the five farmers referred to before, also the comparison of these estimates with the actual weights and prices obtained :—

No.	Actual carcass weight, 8 lb. stones	Farmer's estimates of carcass weights															
		A		B		C		D		E							
	st.	lb.	st.	lb.	st.	lb.	st.	lb.	st.	lb.							
1	106	6	99	6	96	0	98	0	92	4	104	0					
2	104	6	101	4	100	0	101	4	95	0	110	0					
3	103	7	98	0	98	0	98	0	95	0	105	0					
4	93	7	95	3	94	0	91	0	87	4	98	0					
5	93	0	98	0	95	0	99	6	92	4	96	0					
6	102	0	100	5	100	0	96	2	95	0	107	0					
7	98	1	92	6	90	0	89	2	87	4	88	0					
8	105	2	98	0	97	0	98	0	95	0	96	0					
Total of eight bullocks.	807	5	784	0	770	0	771	6	740	0	804	0					
Difference between actual and estimated weights	—		23	5	37	5	35	7	67	5	3	5					
Money loss which would have resulted had the eight bullocks been sold by estimate and not by actual weight (calculated at 4s. 8d. per stone, the price obtained)	—		£	s.	d.	£	s.	d.	£	s.	d.	£	s.	d.			
			5	10	3	8	15	7	8	7	5	15	15	7	0	16	11

Thus, from feeding four bullocks with decorticated instead of undecorticated cotton-cake, a gain of 10 st. 7 lb. of carcass meat resulted, or a money gain of 2l. 11s.

We must now see at what extra cost for food this was produced. The prices of the additional foods used were :—

—	Delivered at nearest station			Cost of cartage, grinding, &c.		Total cost		
	£	s.	d.	s.	d.	£	s.	d.
Decorticated cotton-cake	6	9	2 per ton	4	10 per ton	6	14	0 per ton
Undecorticated cotton-cake	6	2	6 „	4	10 „	6	7	4 „
Linseed-cake	9	7	6 „	4	0 „	9	11	6 „
Barley	1	5	6 per qr. of 448 lb.	2	6 per qr.	7	0	0 „

The food consumed was as follows :—

Food	1st period 62 days. Average per head daily	2nd period 36 days. Average per head daily	3rd period 47 days. Average per head daily	Total food consumed in whole period of 145 days	Average per head daily	Cost of total food consumed
	lb.	lb.	lb.	lb.	lb.	£ s. d.
<i>Lot I. (4 beasts)</i>						
Decorticated cotton-cake	2.73	3	4.29	1,918	3.3	5 14 9
Linseed-cake	2.73	3	3	1,674	2.88	7 3 0
Barley	4	4	4	2,320	4	7 5 0
Roots	40	40	40	23,200	40	
Hay-chaff	8.73	9	9	5,154	8.88	
Water	35	34.22	39.31	21,056	36.3	
<i>Lot II. (4 beasts)</i>						
Undecorticated cotton-cake	2.73	3	4.29	1,918	3.3	5 9 0
Linseed-cake	2.73	3	3	1,674	2.88	7 3 0
Barley	4.00	4	4	2,320	4	7 5 0
Roots	40.80	40	40	23,400	40.34	
Hay-chaff	8.73	9	9	5,154	8.88	
Water	24.95	26.05	32.31	16,016	27.61	

The only practical difference of cost in the foods of the two lots is that between the two kinds of cotton-cake, and accordingly we may briefly put it that the gain of 2*l.* 11*s.* on the four bullocks fed with decorticated cotton-cake was obtained at the extra cost of 5*s.* 9*d.* (5*l.* 14*s.* 9*d.* minus 5*l.* 9*s.* 0*d.*), or a net gain of 2*l.* 5*s.* 3*d.* resulted from the use of 1918 lb. of cake, equivalent to a gain of 2*l.* 12*s.* 10*d.* on the use of one ton of cake. Thus, taking only the feeding value of the cakes into account, and omitting all reference to manurial value, it will be seen that, according to this experiment, decorticated cotton-cake may cost 53*s.* per ton more than undecorticated cotton-cake and yet produce an equal feeding effect.

I have calculated, further, the chemical composition of the average daily diet in either case,

	Decorticated cotton-cake diet	Undecorticated cotton-cake diet
Moisture . . . . .	64.90	65.56
Oil . . . . .	1.52	.91
<sup>1</sup> Albuminous compounds . . . . .	6.85	5.50
Starch, sugar, digestible fibre, &c. . . . .	18.01	19.48
Woody fibre . . . . .	5.18	6.01
Mineral matter (ash) . . . . .	2.64	2.54
	100.00	100.00
<sup>1</sup> Containing nitrogen . . . . .	1.03	.85
Albuminoid ratio . . . . . about	1 : 4	1 : 5

*Relative Manurial Value.*—As the bullocks in the foregoing experiment were kept in boxes, all the dung they made was saved. I thought, therefore, it would add interest to the trial if the two lots were kept separate and tried upon crops. Accordingly this was done, and the manure was used for potatoes. The experiment is described in the Journal, Third Series, Vol. II., 1891, Part II., pp. 376-7. Briefly, the results were:—

Plot	Manure per acre	Produce of potatoes per acre
		tons cwt. qr. lb.
1	12 tons dung made from decorticated cotton-cake . . . . .	8 13 1 20
2	12 tons dung made from undecorticated cotton-cake . . . . .	7 6 3 12

The superiority of the decorticated cake, both for feeding and manurial purposes, was thus clearly brought out by the experiment.

#### EXPERIMENT OF 1890-1.

The repetition of feeding experiments is not only desirable, but frequently also very necessary for the elimination of accidental factors which may have exercised an influence on the results obtained. Besides, when an experiment has been repeated once or twice, under varying circumstances, and the same result in the main is arrived at, the broad general truth to be derived from it is the more firmly established. Seeing the importance of the result obtained in 1888-9, it was considered desirable by the Woburn Sub-Committee to repeat in 1890-1 the previous experiment with decorticated and undecorticated cotton-cake upon bullocks. As Hereford bullocks had been used before, Shorthorns were now tried. The number of animals was also larger, for, instead of having only four in each lot, it was intended to have nine; and accordingly not only the feeding-boxes, but also the enclosed shed and the open yard were utilised. The yard, it may be mentioned, has shelter provided at one end of it by a shed. Experiments have frequently been made for the purpose of seeing whether any practical difference has resulted from feeding in the boxes, in the shed, or in the open yard, but no real difference has been traced, except that, of course, in the boxes all the manure is carefully stored and no urine wasted or superfluous litter used. Of the nine animals to be fed on decorticated cotton-cake four were put in the boxes and five in the open yard,

while four others in the boxes and five in the shed were fed on undecorticated cotton-cake. After about a month of feeding, however, No. 1 bullock in the boxes, belonging to the decorticated cake lot, developed a swelling in its neck which prevented it from eating its food properly; and, although the animal ultimately recovered and nearly made up for lost time, it would not be fair to include it in the experiment; therefore it is omitted throughout. In order to avoid, as far as possible, upsetting the animals by weighing them at the arranged intervals, the bullocks were purchased early in the year (June 1890) and summered on the farm, being weighed several times during the period in order to accustom them to being handled. They were 3-year-old Shorthorns when purchased, and cost 16*l.* 9*s.* each, the average live-weight per head being 9½ cwt. Throughout the summer they only had grass and a little rough hay; later, when brought into the yards, the food of all was kept alike, so that they started under equal conditions. The foods given during the experiment were the same as in the 1888-9 experiments, viz. :—

Cotton-cake (Lot I. Decorticated cake. Lot II. Undecorticated cake.)			
Linseed-cake			
Barley (grittled)			
Roots (swedes to Feb. 15, then mangel)	• • • • •	} <i>ad libitum</i>	
Hay-chaff	• • • • •		

The bullocks commenced feeding with 3 lb. of linseed-cake, 1 lb. of barley, and 2 lb. of cotton-cake per head daily. With the view of bringing out any difference between the two kinds of cotton-cake the above quantities of linseed-cake and barley were kept to throughout, but the cotton-cake was gradually increased, viz. on Jan. 11, 1891, to 4 lb., on Feb. 8 to 6 lb., and on March 22 to 8 lb. of either cake per head daily. The experiment began on Dec. 11, 1890, and closed on April 11 and on April 18, thus lasting for 120 days and 127 days respectively. It was divided further into periods of 40, 42, 38 (or 45) days, at the end of each of which the bullocks were weighed. The foods consumed and the daily average per head were :—

Food	Total food consumed in whole period	Average per head daily	Cost of total food consumed
<i>Lot I. (8 beasts).</i>			
Decorticated cotton-cake	4,974	5·03	16 1 9
Linseed-cake	2,988	3	11 17 9
Barley	996	1	3 6 6
Roots	40,096	40·5	—
Hay-chaff	16,008	16·2½	—
Water	50,176	50·8	—
<i>Lot II. (9 beasts).</i>			
Undecorticated cotton-cake	5,651	5·07	13 17 5
Linseed-cake	3,372	3	13 17 3
Barley	1,124	1	3 15 3
Roots	42,675	39·2	—
Hay-chaff	17,961	16·1	—
Water	55,552	49·9	—

The prices of the additional foods were:—

—	Delivered at nearest station			Cost of cartage, grinding, &c.		Total cost		
	£	s.	d.	s.	d.	£	s.	d.
Decorticated cotton-cake	6	18	6	6	6	7	5	0
Undecorticated cotton-cake	5	5	0	5	0	5	10	0
Linseed-cake	8	12	6	5	0	8	17	6
Barley	1	8	0	2	0	7	10	0
			per ton					per ton
			„					„
			„					„
			0 per quarter of 448 lb.					„

From these prices it will be observed that, owing to market changes, the decorticated cotton-cake cost 11s. per ton more than in 1889-9, and the undecorticated cake 17s. 4d. per ton less, there being now a difference of 35s. per ton between the prices of the two kinds of cake.

Samples of the foods were taken weekly and analysed monthly as before.

The following table gives the average composition of the cotton-cake used:—

	Decorticated cotton-cake	Undecorticated cotton-cake
Moisture . . . . .	9·04	14·44
Oil . . . . .	12·41	5·18
<sup>1</sup> Albuminous compounds . . . . .	45·83	22·35
Digestible fibre, &c. . . . .	21·54	31·38
Woody fibre . . . . .	5·05	21·51
Mineral matter (ash) . . . . .	6·13	5·14
	100·00	100·00
<sup>1</sup> Containing nitrogen . . . . .	7·33	3·58

The eighteen (subsequently only seventeen) bullocks were weighed on Dec. 11, 1890, and divided into two lots of equal aggregate weight; they were weighed subsequently on Jan. 21, 1891, March 4, and April 11 and 18. It being found impossible to dispose of so many as seventeen or eighteen bullocks at one time, and have their carcasses all kept separate, it was arranged to kill one half the number one week and the remainder the next. Accordingly, eight bullocks were weighed on the farm on April 11, then fasted for twenty-four hours and their fasted live-weights recorded. They were given a feed and sent off by train to Oxford, being killed there on April 14; the several quarters, after "dressing," were carefully labelled and weighed the next morning. Mr. Elliott, the manager of the experimental farm, was present all the time and saw to the whole work being accurately carried out. The same procedure was followed with the remaining nine bullocks on April 18 and succeeding days.

In the following table are given the live-weights at the commencement and end of each period of feeding, with the respective gains:—



I.—Eight Shorthorn Bulls fed on Decorticated Cotton-cake, with other Foods (alike in either case).

No.	in boxes	Weights at commencement, Dec. 11, 1890	Weights on Jan. 21, 1891	Weights on March 4	Weights on April 11	Weights on April 18	Gain in live-weight		
		—	—	—	—	—	in 120 days	in 127 days	
1		10 2 5	11 0 7	11 2 22	—	12 3 12	—	2 1 7	
2		11 0 0	12 0 22	13 1 7	—	14 1 14	—	3 1 14	
3		10 3 6	11 1 21	12 0 21	12 3 15	—	2 0 9	—	
4		10 3 18	11 3 5	12 3 14	13 1 20	—	2 2 2	—	
5		10 0 21	11 0 0	11 3 8	12 1 14	—	2 0 21	—	
6		9 3 26	10 3 12	11 2 16	12 1 9	—	2 1 11	—	
7		11 0 7	12 0 2	13 1 5	—	14 0 24	—	3 0 17	
8		9 3 7	10 3 3	11 3 0	—	12 3 14	—	3 0 7	
		84 1 6	91 0 16	98 2 9	51 0 2	54 1 8	9 0 15	11 3 17	
Gain per head daily each period.		2.4 lb.		2.48 lb.	105 1 10 2.28 lb.		21 0 4 2.38 lb.		
		Gain per head daily during entire period, 2.38 lb.							

II.—Nine Shorthorn Bulls fed on Undecorticated Cotton-cake, with other Foods (alike in either case).

No.	in boxes	10 1 15	11 1 16	12 0 25	12 3 4	—	2 1 17	—	
		10 2 7	11 1 12	12 0 25	—	12 3 16	—	2 1 9	
5		10 3 23	10 3 25	11 1 2	—	12 1 4	—	1 1 9	
6		10 3 7	11 0 25	12 0 14	—	12 2 9	—	1 3 2	
7		9 1 26	10 0 26	11 0 26	11 2 14	—	2 0 16	—	
8		10 2 23	10 2 27	11 3 16	12 2 18	—	1 3 23	—	
9		11 1 14	11 3 25	13 0 19	13 3 18	—	2 2 4	—	
10		9 3 10	10 0 12	11 0 0	—	11 2 19	—	1 3 9	
11		10 2 0	10 3 14	11 2 23	—	12 2 8	—	2 0 8	
12		94 2 13	98 3 14	106 3 10	50 3 26	62 0 0	9 0 4	9 1 9	
Gain per head daily each period.		1.33 lb.		2.36 lb.	112 3 26 1.82 lb.		18 1 13 1.84 lb.		
		Gain per head daily during entire period, 1.84 lb.							

The fasted live-weights, carcass weights, and other particulars are given in the following table :—

I.—Decorticated Cotton-cake Lot (8 bullocks).

No.	Live-weights on farm	Fasted live-weights in cwt. qr. lb., also in stones of 14 lb.		Loss in fasting	Carcass weights in 8 lb. stones	Percentage of carcass	Price realised at 4s. 4d. per stone dead-weight
	cwt. qr. lb.	cwt. qr. lb.	st. lb.	per cent.	st. lb.	per cent.	£ s. d.
2	12 3 12	12 1 22=99	8	3.2	103 6	59.6	22 9 9
3	14 1 14	13 2 26=109	12	4.5	111 7	58.7	24 4 11
4	12 3 15	12 1 3=98	3	4.7	97 6	56.9	21 3 9
14	13 1 20	12 3 18=103	4	3.9	107 7	59.7	23 7 7
15	12 1 14	11 3 13=94	13	4.1	96 2	57.9	20 16 3
16	12 1 9	11 3 8=94	8	4.1	97 4	58.9	21 2 7
17	14 0 24	13 2 9=108	9	4.5	109 0	57.3	23 12 6
18	12 3 14	11 3 26=95	12	6.9	96 7	58.3	20 19 10
—	105 1 10	100 2 13=804	13	4.5 average	820 7	58.4 average	177 17 2
Average per head					102 5	—	22 4 8

II. *Undecorticated Cotton-cake Lot (9 Bullocks).*

No.	Live-weights on farm	Fasted live-weights in cwt. qr. lb., also in stones of 14 lb.		Loss in fasting	Carcass weights in 8 lb. stones	Percentage of carcass	Price realised at 4s. 4d. per stone dead-weight
	cwt. qr. lb.	cwt. qr. lb.	st. lb.	per cent.	st. lb.	per cent.	£ s. d.
5	12 3 4	12 0 8	= 96 8	5.59	96 7	57.3	20 19 10
6	12 3 16	12 2 4	= 100 4	2.8	103 3	58.9	22 7 11
7	12 1 4	11 2 13	= 92 13	6.1	94 0	57.8	20 7 4
8	12 2 9	12 0 0	= 96 0	4.6	99 1	59.0	21 9 7
9	11 2 14	11 0 14	= 89 0	4.3	90 0	57.8	19 10 0
10	12 2 18	11 3 16	= 95 2	6.1	93 2	56.0	20 4 1
11	13 3 18	13 0 18	= 105 4	5.4	103 2	56.0	22 7 4
12	11 2 19	11 0 2	= 88 2	5.5	90 6	58.8	19 13 3
13	12 2 8	11 3 21	= 95 7	5.0	93 6	56.1	20 6 3
—	112 3 26	107 1 12	= 858 12	5.04 average	864 3	57.5 average	187 5 7
Average per head . . . . .					96 0	{ in money value }	20 16 0
Gain per beast in Lot I. over each in Lot II. . .					6 5		1 8 8

The cost of the decorticated cake consumed during the whole period by the eight bullocks of Lot I. was 16*l.* 1*s.* 9*d.*, or 2*l.* 0*s.* 3*d.* per head, and of the undecorticated cake consumed by the nine bullocks of Lot II. 13*l.* 17*s.* 5*d.*, or 1*l.* 10*s.* 10*d.* per head. Thus it will be seen that a gain of 1*l.* 8*s.* 8*d.* per head was obtained at an extra expenditure of 9*s.* 5*d.*, leaving a net profit of 19*s.* 3*s.* on each beast fed upon decorticated cotton-cake. In other words, each ton of decorticated cotton-cake used would give an increased value of 3*l.* 9*s.* 4*d.*, supposing the prices of the two cakes to be alike. This allows, therefore, of decorticated cotton-cake being 3*l.* 9*s.* 4*d.* per ton dearer than undecorticated cotton-cake in order to produce an equal feeding effect.

This result with Shorthorn bullocks is even higher than that obtained in the 1888-9 experiment, when Hereford bullocks were used, the allowed difference of cost between the two cakes being then ascertained to be 53*s.* per ton.

Combining the two years' results, and without putting too much importance upon the particular money figures, it may, I consider, be fairly maintained that, for feeding purposes alone, and omitting manurial value (which would put the balance still more in favour of the decorticated cake), decorticated cotton-cake is fully worth 50*s.* a ton more than undecorticated cotton-cake.

J. AUGUSTUS VOELCKER.

## REPORT OF THE CONSULTING ENTOMOLOGIST.

**DIAMOND-BACK MOTH.**—The observations on this pest are included in the detailed report (see page 596), of the recent attack.

**MANGEL FLY LEAF MAGGOT.**—In the earlier part of the summer—that is, during June and July—one of the most important infestations noticed has been that of the mangel fly leaf maggot, *Anthomyia beta*. This was widespread. I had notes of it from Knowle, and from the district near Rugby in Warwickshire, and from the Banbury district in Oxfordshire, as present in Herts and Cambridgeshire, as very bad near Hawkhurst, Kent, and as injurious in Devon, and especially hurtful over the North Devon district.

The first observations were sent me on June 22, and the amount of harm done was described by various correspondents in June or early in July as “considerable damage”; “scarcely a plant escaped”; and “total failure.”

Notwithstanding this infestation being one which occurs more or less every year, the injury has in many cases not been recognised as attributable to insect attack, and inquiries have been sent me as to its being a newly-arrived trouble to mangel. It may make some difference in future attention to preventive measures for it to be more generally known that this patched and blistered state of mangel leaves is not due to damage from frost or sun-scald, but from the working of fly maggots in the tissues between the upper and under sides of the leaf.

These small whitish or greenish maggots feed for about a month in the leaves, and then mostly drop from the leaves to the ground, where they turn to chrysalids, in small oval chestnut-brown chrysalis cases. From these the small grey-and-black two-winged flies come out in about ten days or a fortnight, and proceed to start new attacks by laying their white spindle-shaped eggs beneath the mangel leaves. Thus attack may go on all summer.

The first burst of attack is usually much the worst, as the young plants with their small supply of leafage fail most rapidly under the injury.

I have advised all inquirers that the best treatment appears to be the application of stimulating dressings, which may push on healthy leaf growth, and replace the leafage killed by the maggots as soon as possible. These may be chosen according to requirement of the land, but I have especially drawn attention to the successful use of nitrate of soda as a means of saving mangel much injured by maggot; as shown, amongst other instances, at Rothamsted last summer.

Cutting off maggot-infested leaves, or pieces of them, and destroying them, answers excellently in preventing local and immediate recurrence of attack, but for the time being the removal of the leafage in this way is as injurious as the loss through maggot blisters.

TARE MIDGE GNAT (?sp.).—By the help of plentiful specimens sent me from a locality in Surrey, I have ascertained that the stunted and deformed growth of the flowering heads of tares, which sometimes does a good deal of mischief, is caused by a small maggot of the same nature as the red maggot of wheat; that is, by the maggot of a small two-winged midge gnat, or scientifically a *cecido-myideous larva*. The full history of this, which I hope to procure, may possibly throw some light on that of the clover seed maggot.

TURNIP SAWFLY.—A single report has been sent from a district in Lincolnshire of a turnip attack, which I found to be that of the turnip sawfly, *Athalia spinarum*. This infestation is quite as destructive in its nature as that of the caterpillars of the diamond-back moth, but from the different habits of the grubs is far more easily checked. These sawfly grubs are at first white or greenish-white with black heads, and, when nearly full grown, are slate colour with some paler stripes, &c. They may be very easily distinguished from the diamond-back caterpillars, which have only four pairs of sucker feet, by having seven pairs of sucker feet or prolegs beneath the body (as well as the tail pair and the claw feet, which the moth-grubs possess also). As these sawfly grubs devour the leaves, and do not hide under them, there is no difficulty in reaching them.

All the ordinary treatment of dressings or mechanical measures of sheep driving, or passing scufflers with boughs on them, &c., may be used with every hope of success. Also the fact that the sawfly caterpillars moult every six or seven days helps us greatly, as during this operation it is necessary for them to hold on by the kind of sucker feet at the end of the tail to something firm, to enable them to draw themselves out of their old coat. If they cannot do this they perish; therefore any measures, such as those above mentioned, which will dislodge the caterpillars are of service.

FRUIT INSECTS.—Observation by the Evesham Fruit Committee and other fruit growers both of the histories, and of practical methods of suppression of various kinds of fruit insects, has taken place during the last two months, but time does not allow details of these now.

ELEANOR A. ORMEROD.

July 28, 1891.

## THE DIAMOND-BACK MOTH.

On August 7, I was requested by Mr. Ernest Clarke, Secretary of the Royal Agricultural Society, to prepare a paper on the recent attacks of caterpillars of the diamond-back moth for the forthcoming number of the Society's Journal. Much information was then in my hands with regard to the localities of the first-observed appearance of the caterpillars during the preceding weeks, and the destructive amount of attack to turnip leafage which had imme-

diately followed. Further information was, however, desirable as to whether the subsequent damage and consequent money loss from the attack had been to the extent apprehended, and also as to what remedies had been tried, what was their success, and generally any information bearing serviceably on the matter from observers acquainted with the infestation, so as to be able to distinguish it trustworthily from that of turnip sawfly or other attacks to turnip leafage.

With this object I at once arranged a short circular requesting information on the following points:—

1. *Any estimate of amount of loss, whether in acreage, mileage, or money loss on crop.*

2. *Any measure found to answer in lessening amount of ravage, or loss from its effects; as, for instance, effect of fertilisers, as nitrate of soda, superphosphate, soot, lime, &c., given as dressings to push on crop; or any dry or fluid dressings applied to the leaves to clear the grubs, and how*

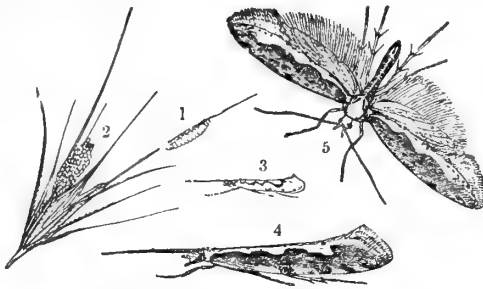

FIG. 1.—PLUTELLA CRUCIFERARUM.

1, Caterpillar; 2, eggs; 3, diamond-back moth (all natural size); 4, 5, diamond-back moth, at rest and flying (magnified).<sup>1</sup>

applied, as by strawsonizer, knapsack sprayer, &c.; also effects of any mechanical measures, as taking horse-hoes, or scufflers with boughs on them, through the crops; or use of "sheep-driving."

3. *Opinion asked as to benefit of heavy rains.*

4. *Nature of land*—also how cultivated (especially whether autumn cultivated and whether ploughed deeply)—what manure was used, and was salt used?

5. *Was weather* observably wet or dry in previous autumn, so as to cause difficulty in cleaning the land, and was any particular weed unusually noticeable?

6. *Is this caterpillar* found to especially frequent charlock?

7. *What kinds of birds* are especially useful in clearing the caterpillars?

This circular I forwarded to my correspondents, requesting to be favoured with replies, and in the following pages I have embodied (with due acknowledgment to the contributors) the chief points of the information sent me regarding this year's attack, and also of the information previously in my hands.

This I have divided in the following pages under three headings.

<sup>1</sup> This figure is inserted by permission of Messrs. Blackie & Son, Glasgow.

The first refers mainly to recorded dates of previous appearances of the infestation, when occurring to an injurious extent, and also gives description and life history of this *Plutella cruciferarum* (of Zeller) in its different stages.

The second gives the observations of the appearance of the attack at various localities during the past summer, with dates of observation and names of contributors, also some special notices of observations of flocks or great numbers of moths (in some cases certainly, in some presumably, the diamond-back moth) at various places on the eastern coast of England and Scotland shortly before the outbreak of the caterpillars.

Under the third heading I have placed the information sent in reply to my circular—these replies being placed respectively under headings of inquiries to which they refer—and to these notes the initials of the contributors whose names are, for the most part, given in the preceding section are appended.

#### PREVIOUS APPEARANCES OF THE MOTH IN GREAT BRITAIN.

The first regularly recorded appearance of the caterpillars of the diamond-back moth in numbers sufficient to be the cause of serious ravage is, as far as I am aware, that noted by John Curtis<sup>1</sup> as occurring in the neighbourhood of Petersfield, Hants, in August 1837. The writer notes, however (accompanying), that he has little doubt that it was the same kind of caterpillar which did much harm at a locality in Forfarshire in 1826. The next notice of severe injury after 1837<sup>2</sup> appears to be that given in detail in 1851 by Professor I. O. Westwood (still our highest entomological authority) of bad attacks occurring in some parts of Cornwall, and also in Nottinghamshire, and it was from the caterpillars causing the inland devastation that Professor Westwood identified the attack and drew the very characteristic figures accompanying his description.

Later on, in 1854, Mr. Stainton (the special authority on moths of this group<sup>3</sup>) mentions that "in 1851 this insect was excessively abundant throughout the country, and from Southend in Essex to Belfast the same enormous multiplication of the species was observed. The turnip growers thought some new blight had fallen on their crops, but fortunately subsequent years have not shown a continuance of the inordinate numbers of this species."

In *Farm Insects* of John Curtis (published 1860, with preface by the author bearing date January 1859) no further reports of injurious presence are added by him to his previous notice of this insect, therefore presumably there had not been a further visitation of it.

In 1883 I had observations of damage occurring at two localities in Yorkshire, also near King's Lynn, Norfolk, and Harwich, Essex; and in 1884 I had again observations of diamond-back presence

<sup>1</sup> Journal R. A. S. E., Vol. III. (1st Series), p. 71.

<sup>2</sup> See *Gardener's Chronicle and Agricultural Gazette*, 1851, p. 484.

<sup>3</sup> Stainton's *Tineina*, p. 67.

from Yorkshire, in one case near Northallerton, in the two others at the same localities as in the previous year, namely, near Market Weighton, and Holme Hall, York. Attack was also reported, and as very bad, near Inverurie, Aberdeenshire, N.B.

In the present year the infestation has been more or less present along the eastern coast, or eastern side of the country from Dover up to Aberdeen, and I have also observations of its presence near Fishguard, Pembrokeshire, near Newport, Salop, and near Lytham, Lancashire; and also in the island of Islay, on the West of Scotland; and from general information it may reasonably be presumed to be present at many other places, including localities in the west and north of Scotland. Later on, that is about August 14, the presence of the infestation was announced in Ireland, especially along the eastern coast, and I had opportunity of identifying specimens from Dunleer, co. Louth.

In this country, though it is rare to have bad attacks, yet the insect is common and abundant in many places during the summer. Elsewhere it is widely distributed—being injurious even in Cape Colony. Nearer home its presence as a Continental pest may prove an important consideration with regard to transmission of wind-borne infestation. That moth attack can be so brought is well known, as, to give a single instance, in the case of the silver Y moth, the *Plusia gamma*, which crossed over from the Continent in the summer of 1879; but whilst in this case, from the size of the moths, the flocks could not escape observation, with the little diamond-backs there is no such necessity of observance, and their appearance was little thought of until a reason for the vast appearance of caterpillars came under consideration.

#### DESCRIPTION OF THE MOTH.

The size of these moths is only about, or rather under, two-thirds of an inch in the spread of the wings, and to ordinary observation when at rest they appear as brownish-grey moths, about the size of furniture moths, but long and narrow in shape. When at rest, and the upper wings laid along the back, with the edges meeting, the pale patterns along these edges form diamond-shaped marks, whence the English name "diamond-back moth"; if seen sideways, the curved up extremity of the wings as shown at 3 and 4 in the figure on page 597 is very striking.

On minute examination it will be found that the front wings are long and narrow; greyish brown, darker towards the centre, but marked with some small brown spots in front, a rather broad whitish or ochreous-grey band runs along the hinder margin, with three rounded projections on its front edge; this band is usually spotted with very small dark points, and in some specimens it is considerably obscured by the ground colour on the hinder margin, leaving the three projecting parts alone conspicuous. The hind wings are narrow and pointed at the apex, have a long fringe, and are of a pale ashy-grey colour. The body and legs are brownish grey,

the head and thorax grey or ochreous grey, antennæ white, with some brown or fuscous rings.

The moths lay their eggs for the most part on the underside of the leafage of their food plants, and we see plainly that this is the usual ravaging ground of the caterpillars ; still, they may be present sometimes on other parts of the plants.

The caterpillars, when full grown, are about half an inch long, and peculiar in shape, as they taper slightly towards each extremity. This is a marked characteristic. The colour is usually a delicate green or apple green, but this is variable ; in younger state the larva is often yellowish or greyish, with black head.

When near full growth the head is usually grey or yellowish, marked with small black dots, and the next ring is remarkable for the *absence* of the two dark patches often found in small caterpillars of allied kinds, and instead has a number of very minute black specks. The rest of the segments have a few black dots, each bearing a bristle, but these cannot be made out without the help of a magnifying glass. Each of the first three segments bears a pair of claw feet, and there are also four pairs of sucker feet beneath the body, and another pair (which are very noticeable from being set out somewhat obliquely) at the end of the tail extremity. When alarmed, the caterpillar lets itself down by a thread, and swings in the air till it thinks fit to return by the thread to its previous locality.

How long the caterpillar feeds I do not find noted. The nearest approach to time I find is the observation of Dr. Taschenberg regarding caterpillars from eggs laid in May (or found feeding about the beginning of June) spinning their cocoons about the beginning of July. The cocoons are formed on the under surface of the leafage of the food-plants, or on stems, or amongst seeds, &c.—in fact, in any convenient place on or near the food-plant, and vary somewhat in appearance ; sometimes they are a mere open network of white threads, sometimes thicker, and of a somewhat boat-shaped form, in the former case the colouring of the chrysalis can be distinctly seen through the network. The characteristic colouring when nearly mature is whitish with some black streaks. This was very noticeable in some cocoons sent me by Mr. Moss of Feering, Kelvedon, Essex, from which diamond-back moths very shortly came out. In the early part of their formation the chrysalids may be green or brownish ; there appears to be a good deal of variety in this matter, so far as I can judge from the many specimens which have passed through my hands this year.

The time spent in chrysalis state is also variable. Professor Westwood gives it as from 10 to 18 days, John Curtis as about 11 days, and Dr. Taschenberg as about three weeks. The first two observations were from specimens presumably under shelter, and the difference points to the effect which weather favourable to the development of the insect may have in increasing the prevalence of this scourge. The second generation begins its ravages about August, and the chrysalids from the last brood of the year remain in chrysalis state through the winter.



The food plants of the diamond-back caterpillars are, by preference, turnip, cabbage, and other cruciferous plants, including notably what we know in England as "Charlock" (*Sinapis arvensis*, L.), in Scotland as "Runches" or "Skellocks." It also attacks, amongst other weeds, "Jack-by-the-hedge" (*Sisymbrium Alliaria*, Scop.), a common hedge, or ditch-side plant of early foliage; also the Hedge Mustard or Flixweed (*Sisymbrium Sophia*, L.); and it is stated to attack the Saltwort (*Salsola Kali*, L.), a plant to be found on sandy shores, but on inquiry I did not find that this plant had been observed as being infested in the past summer.

The specific scientific name appended to that of *Plutella* (namely *cruciferarum*) is a very appropriate one, as it well describes the habits of the caterpillar in mainly feeding on *cruciferous* plants, namely those of the cabbage kind. The word *Xylostella* appended to *Cerostoma*, by which synonym this moth was formerly known, refers to the habit it was in early days of observation supposed to have of feeding on the *Lonicera Xylosteum*, L., the upright or two-flowered honeysuckle, a shrub to be found in thickets, and more especially in Sussex.<sup>1</sup>

Here, however, it seems to me that there may have been some confusion of species. As the case stands at the present day, the *Cerostoma Xylostella* of Stainton's Manual is distinguishable by several clear characteristics from *Plutella cruciferarum*.

The moth of *C. Xylostella*, besides being rather broadly yellowish-white along the hinder margin of the upper wings, "has an extremely narrow oblique white streak running half across the wing beyond the middle." Also the caterpillars are green with a broad red stripe on the back and are tapering to the head end, and make a firm cocoon.<sup>2</sup>

During my own investigations, I found a very few green caterpillars striped with brown or reddish brown which may possibly have been of this kind.

The only parasite insect foe of the diamond-back caterpillars appears to be a small Ichneumon fly, *Campoplex*, given by John Curtis as *paniscus* of Gravenhorst. This is only about a quarter of an inch in length, with ovipositor almost half the length of its body, and somewhat under half of an inch in expanse of the wings, black, with legs for the most part reddish, and with two pairs of transparent iridescent wings. This insect is stated by John Curtis "to be abundant in July upon almost every umbelliferous plant in fields and hedges, feeding in the flowers, and searching for caterpillars for the purpose of depositing eggs in them."

#### PARTICULARS OF THE RECENT ATTACK.

The following notes chiefly refer to first observations in the summer of 1891 of the diamond-back moth caterpillars, and the ravages on turnip leafage immediately following, and are for the most part given with date, also with name of sender and locality of

<sup>1</sup> *Manual of British Botany*, by Charles Cardale Babington, F.R.S.

<sup>2</sup> See Stainton's *Vineina*, p. 70.

attack. Several are isolated observations, but where practicable, they are arranged under the headings of their respective counties, and these under the headings of England and Scotland, with some small amount of observation of presence of the infestation in Ireland.

#### ENGLAND.

*Yorkshire.*—The first communication which I received regarding presence of the caterpillars of the diamond-back moth was sent me on July 2, from Long Whins, Hunmanby, Yorks, by Mr. Robt. W. Smith, as follows: "Herewith I send you leaf of a turnip with specimens of caterpillar which has on some farms in the neighbourhood entirely destroyed the turnip crop and is fast destroying it on my own." The specimens forwarded were much eaten from the underside so as often to leave mere patches of the upper cuticle of the leaf remaining, and sometimes even this was eaten through. The caterpillars accompanying were of various tints, from yellowish colour to apple green, and of various sizes from a quarter to full grown.

On July 22, specimens of turnip and cauliflower plants infested by diamond-back caterpillars were forwarded by Mr. Thos. Brown, Pocklington, Yorks, with mention that, according to report received, scores of acres were similarly affected.

On July 21, report was sent from Spiker's Hill, West Ayton, Yorks, on the part of Mr. Thos. Darrell, mentioning that caterpillars (of which specimens showing them to be diamond-backs were subsequently sent me) were eating up all turnips and swedes in this locality.

On July 24, specimens were sent from Lebberton, near Filey, Yorks, by Mr. John P. Darrell, with mention that the attack had somewhat abated since the previous communication, as some nice showers had fallen which seemed to strengthen the plant.

Mr. G. W. Clark, auctioneer and valuer, Great Driffield, Yorks, (from whom, as will be seen further on, I had subsequently valuable notes as to different amount of attack on different nature of land), forwarded me diamond-back caterpillars on July 24 as specimens of the pest that was making havoc of the turnips.

On July 25, Mr. Pippet, agent for Lord Herries, of Everingham Park, York, forwarded specimens of badly injured turnip leaves, together with diamond-back caterpillars, and the observation that the attack was ruining whole fields of turnips in the district.

On July 29, inquiry was sent me by Lord Auckland from Edenthorpe, Doncaster, regarding the diamond-back caterpillar which had been devastating fields in that neighbourhood; and on July 31, Lord Auckland further mentioned that on visiting one of his fields that morning, he found great numbers of specimens, including caterpillars, chrysalids, and moths, but the latter form was the most numerous. Lord Auckland was good enough at the time to reply to some of my inquiries, which answers are placed with those with which I was afterwards favoured by observers in reply to my circular.

On July 26, Mr. Frederick Reynard reported from Sunderlandwick, Driffield, with specimens accompanying, that the caterpillars had been troubling him for the last fortnight, but were considerably less in numbers than they were a week ago.

*Lincolnshire.*—On July 17 Mr. William H. West, of Holbeach Marsh, Lincolnshire, forwarded me specimens of the caterpillar of the diamond-back moth, with the observation that it was making terrible havoc with the swede turnip in the district. Also that it had appeared all at once on the previous Monday (July 13) and had attacked all crops alike, whether they had been affected by the ordinary turnip fly or not, and was likely to be most disastrous to agriculturists.

On July 20, Mr. West further wrote that the swede crop in the district was very generally affected, and that some of the caterpillars had then spun their cocoons; and, on July 29, Mr. West wrote me that the turnips on the best lands were outgrowing the caterpillar.

The following note, sent me on July 20, is from a resident in N.W. Lincolnshire, in the district between the small river Ancholme and the Trent, on the oolitic limestone. As the sender did not wish his name affixed, I give his communication simply as from "N. Lincs." "My swedes and many more in the district are giving way from multitudes of caterpillars on the underside of the leaf." The leaves sent were not very severely injured so far—and one of the caterpillars appeared to be just on the point of spinning up.

Mr. J. Eardley Mason, writing from the Sycamores, Alford, Lincs, on August 9, mentioned "diamond-back moth larva everywhere, but damage very various in amount—nothing like what is reported from Northumberland; some pieces have escaped altogether."

On August 15, I was favoured with the following information by Mr. W. Frankish of Limber, Ulceby. This refers to joint ravages of the caterpillars of the turnip sawfly and of those of the diamond-back moth. Mr. Frankish wrote: "I have looked round my three fields of turnips which were more or less attacked by the caterpillars of one description or the other, but I have no doubt by both, and find they have by no means recovered their lost ground. The swedes (fortunately only about eleven acres) are almost worthless, and now cannot be at the best more than one-third of an average crop, and a crop of common turnips next to them (thirty-eight acres) in the same field cannot be more than half a crop, while two other fields of common turnips, fifty-nine acres, will possibly get two-thirds of a full crop; turnips sown before and after these fields, about 200 acres, have not been attacked, that is to say to any serious extent."

"The specimens I sent to you from Brigg Show were brought to me there by a neighbour on an adjoining farm, but I have no doubt we all had the two enemies, as the leaves were eaten in different ways: one almost entirely except the centre stalk; the other leaving all the fibre like gossamer almost, or coarse network, but it would be impossible for me or anyone to separate the damage by different caterpillars."

*Norfolk.*—On July 21, Mr. Edward Atmore wrote from King's Lynn, Norfolk, mentioning the ravages of the caterpillars of *P. cruciferarum* in the N. and N.W. parts of Norfolk, near the sea; also that on July 18, when in fields of turnips near King's Lynn, he observed these insects present in all stages—that is, egg, caterpillars of various growths, chrysalids, and moths, and already the crops had suffered so severely that unless something was done they seemed doomed to destruction.

Report of very bad attack was sent by Mr. John Hammond, M.R.C.V.S., from Bale, Dereham, on July 24. Cocoons as well as caterpillars were now present, and it was mentioned that "some hundreds and possibly thousands of acres are thus affected in the neighbourhood, and almost every turnip in a field more or less injured, threatening a serious loss to farmers."

Some much injured leaves were sent from Horsey, Great Yarmouth, with the small green caterpillars, and the remark that these attack the leaves from beneath and take off nearly all the crop, and shortly after, on July 21, Mr. Rising wrote further, mentioning that the caterpillars appeared only on the underside of the leaves which, where they had been present, had the appearance of fine muslin. This comparison, or the term "lace-work" applied elsewhere, well describes the fine film, formed merely of the remains of the upper cuticle of the leaf (supported by the chief veins), to which the leaves are reduced in bad attacks of these caterpillars.

On August 8, Mr. C. C. Rising, writing from Oxnead Hall, Norwich, mentioned that his turnips were very much injured by the diamond-back moth attack.

*Suffolk and Norfolk.*—One of the most important of the first notes of attack of the diamond-back infestation which I received was sent me on July 18, with specimens accompanying, by Mr. Ernest Clarke, Secretary of the Royal Agricultural Society of England, on the part of Mr. Garrett Taylor, Member of Council of R.A.S.E., of Trowse House, Norwich. Mr. Clarke wrote me that he was informed that the caterpillars were making fearful havoc among the swedes—in fact, a field of thirty acres had been completely eaten away—and I was urgently requested to telegraph to Mr. Taylor at the earliest moment, as there was as much harm being done as if there was a swarm of locusts.

The infestation occurred in the parishes of Whitlingham (Norfolk) and Corton in the N.E. of Suffolk, and on July 21 Mr. Garrett Taylor wrote me: "You are quite right in stating that, when the attack does come, it is apt to sweep the whole crop before it, and this is what it has done at Corton, near Lowestoft. We have given a heavy dressing of paraffin with the 'Strawsonizer' and some of the smaller tenants have 'scuffled' the swede crops with boughs, and having had some very heavy rains we are hoping that the crop will now outgrow the attack, where it has not been so overwhelming as in some parts of Corton."

On July 30, Mr. Garrett Taylor wrote me further: "I think the best remedy that has yet been found is a mixture of three-

quarters soot and one-quarter lime, and sown on the plants. I am glad, however, to say that the top dressing of nitrate of soda and salt that I have given mine, combined with the heavy rains, has already afforded an impetus to the plants; so much so, I think they are growing away from the little pests and will now do, I hope."

Two days after, that is, on Aug. 1, Mr. Taylor reported further "that the heavy rains appear to have killed all the caterpillars, and very few cocoons are left on the leaves, but the roots are slow in recovering. One of our tenants at Corton used a 'scuffer' (filled with boughs) on some swedes which were not hoed out; this answered very well, and the plants are now growing well."

Later on Mr. Garrett Taylor favoured me with further valuable information in reply to my circular, which is given subsequently under the respective headings of inquiry.

The following observations are for the most part notes of isolated local or district observations, but are recorded, as it is presumable attack was more widely distributed, and in any case they are links in the chain of evidence showing that the infestation was present at greater or less intervals from Aberdeen to Dover, also on our western coast, and not wholly absent inland.

*Durham.*—Mr. Rowland Burdon, of Castle Eden, forwarded specimens of the moths and caterpillars on July 24, with the following information: "I have a field of swede turnips close to the sea—some 12 acres—almost every leaf of which is covered with these caterpillars, and in the same state as the enclosed specimens—and as there are quantities of these small moths flying about, I fancy they are the source of the mischief.

"The attack only commenced a week ago—we had dry weather till St. Swithin, and every day till yesterday since then has been wet more or less. The swedes would be meeting in the rows in a fortnight, but now look as if the whole field would be spoilt."

*Essex.*—About August 7 very characteristic specimens of cocoons were sent me which had been spun on seeds of a crop of cress near Kelvedon. These gave me the opportunity of rearing very perfect specimens of the diamond-back moths.

*Kent.*—On July 31, Mr. Montague Kingsford, of Littlebourne near Dover, reported that he had found that day in a 3-acre piece of Brussels sprouts, that a caterpillar had ravaged the leaves from underneath, and had almost destroyed the plant. He also found traces of it in a field of thousand-headed cabbage some distance from the Brussels sprouts. Specimens sent were for the most part spun up

*Salop.*—On Aug. 3, Mr. T. H. Ward, of Ellerton Grange, Newport, Salop, in reference to previous communication regarding caterpillars affecting the turnips, forwarded me specimens which showed the attack to be of the diamond-back caterpillars, then ravaging the leaves, and also some of the damaged leaves accompanying.

The following note refers to observation of the caterpillars at Treathro, Fishguard, Pembrokeshire. Mr. W. Reynolds, writing on July 28, reported: "Enclosed I beg to send you samples of turnip

leaves affected by some caterpillars, some of the worst part sent ; the crop was sown early and is very forward, but the whole of some three acres affected."

*Lancashire.*—Specimens of the same kind of attack were also sent me by Mr. Thos. Fair from the Estate Offices, Lytham, Lancashire, with information sent shortly after (on Aug. 13) that three statute acres of turnips had been rendered quite useless by the attack.

The above notes show the infestation as to some degree present in the western counties, though later in date, and, so far as recorded, at very few localities ; and thus the observations circle down the east coast and up the western country till we return to the North of England, where attack was excessively prevalent.

*Northumberland.*—On July 22, swede leaves so badly injured by the caterpillars as to be "muslined," *i.e.* reduced to a mere thin film of the upper cuticle of the leaf, were forwarded me from Goswick, Beal, R.S.O., by Mr. L. Morley Crossman.

A note was also sent me by Mr. Henry Annett, from the Cottage, Widdrington, Northumberland, with caterpillars of the diamond-back of various ages and colours, and also injured leafage, mentioning that large areas of turnips were apparently being ruined in the district by means of this caterpillar.

Samples of the diamond-back moth, as well as the caterpillars, were forwarded me on July 24 from Waren House, Belford, by Mr. J. Burdon Sanderson, with the observation that the caterpillars were taking the swedes and turnips in this county wholesale, some fields being almost left as if no turnips had ever been there. They were also on some of the writer's kohl rabi and drum-head cabbages.

At the same date as the above, Messrs. S. Finney and Co., Newcastle-on-Tyne, forwarded diamond-back caterpillars with the following account of the widespread ravage then going forward :—

"We beg to enclose you some specimens of a caterpillar which the last few days has almost entirely eaten up the crops of turnips and swedes ; it has also attacked cauliflower and savoy plants ; it seems to extend all along the sea-coast to beyond Berwick-on-Tweed, and to go inland above five miles ; the first indication was the appearance of small white winged insects, the size of the house moth. It is painful to see large sturdy turnip plants riddled like a sieve, wither, and die."

Information was also placed in my hands by Mr. Fenwick Wilson, of Marden, Whitley, which is given under the headings of the points referred to, with that of other contributors, in reply to my circular, and also under headings of observations, of great appearances of moths preceding attack.

#### SCOTLAND.

*Berwickshire.*—On July 21, Mr. Jas. Gibson, writing from Gun-green, Eyemouth, N.B., mentioned that an unusual pest had recently fixed on the turnip crop in that particular part of Eastern

Berwickshire. He observed: "Until ten days ago the turnips appeared quite healthy and promised to be an abundant crop, but when walking through the fields at the end of the previous week he observed a few of the leaves drooping, and on examination found perforations caused by a small caterpillar." A large number of specimens were sent me, and about three-quarters of the under surface of the leaves might be estimated as destroyed on those least attacked, and amongst the caterpillars there was a larger proportion, still young, than amongst other samples which had been sent me from more southerly localities. Mr. Gibson noted that the crop was then disappearing by acres, and he feared would prove a complete failure. Also that the damage was not confined to Mr. Gibson's own farm, but various holdings in an area of three miles appeared to be similarly affected.

A few days later Mr. Gibson further mentioned: "All round the coast here the plague of caterpillars is very prevalent; inland it is not so bad," and on August 8 Mr. Gibson mentioned that of one of his fields of 20 acres, there would not be 5 acres altogether left, and even these would not yield half a crop. Another field of 16 acres would not have more than 4 acres in the whole field.

On July 28, Mr. F. Norman, the Mayor of Berwick, reported wide spread of the caterpillar scourge in the vast expanse of turnips grown in the district, and noted the pitiable appearance on the previous evening, the leaves of acres upon acres being quite bleached, or frosted in appearance, from the light of the setting sun shining through the epidermis, or upper film of the surface of the leaf "which the caterpillars considerably leave intact." He also observed: "In this district the cocoon spinning has begun and is fast proceeding."

*Haddingtonshire.*—On July 23, Mr. John Begbie, writing from Queenstonbank, Drem, a hamlet in N. Haddington, N.B., forwarded me leaves of swedes and yellow turnips showing caterpillar attack which had appeared a few days previously and already done much damage. Mr. Begbie reported that the whole of that district along the sea-coast from Dunbar as far as, say, about 13 miles from Edinburgh, appeared to be attacked, but inland he had heard of no damage. Early swedes and yellows were noted as having escaped in some places.

*Fifeshire.*—The first publicly recorded observation of the appearance of the diamond-back moth during the past season was, as far as I am aware, that made by Mr. Andrew Balsillie, of St. Andrews, and communicated by him at the time to the *Scotsman* newspaper. Afterwards, on request for information, he wrote me that on the very last days of June an extraordinary number of small grey-brown moths were observed all along the eastern seaboard of the county of Fife infesting the turnip fields. Their appearance was coincident with a period of long-continued drought, and though the plants had braided, they were making exceedingly little progress. On Monday, July 20, or as nearly as may be three weeks after the appearance of the moths, both swede and yellow turnips presented

the appearance as if lime had been sown on them. On looking more particularly, it was found that the plants were infested with small green caterpillars which had eaten the under side of the blade, leaving the thin film on the surface. In this way whole fields were destroyed. In other cases portions of a field seemed to escape with comparatively little damage.<sup>1</sup>

On July 20 (the same date at which Mr. Andrew Balsillie, of St. Andrews, noted the great injury from caterpillar), Mr. David Carswell, writing from Rathillet, Cupar, Fife, about nine miles west of St. Andrews, forwarded me specimens of diamond-back caterpillars with the observation that they were eating to a large extent a field of his yellow turnips. The following day he wrote me that he heard in the market great complaints of this green caterpillar as being all over Fife, and some fields eaten up; likewise that when in the field that morning he saw a great many white moths<sup>2</sup> which he presumed were the progenitors of his caterpillars, and again on the 23rd (notwithstanding very heavy rains) the moths were still about.

In the following observation, though from subsequent communication it was plain the attack was of diamond-backs, the little moths, as I saw them at first, were indistinguishable as to species.

On July 7, specimens of moths were sent by Mr. John Lee, of Coates, near Largo, Fifeshire, who mentioned that they were very numerous, especially on the turnips which he had not singled, but that no caterpillars were to be found even after careful search. On July 25, Mr. Lee further wrote that caterpillars were very numerous on the fields on which the moths had been seen flying.

On July 22, Messrs. Drummond added to previous communications regarding the diamond-back visitation: "We have complaints of it from east and north of Fife, of Kinross, and Forfarshire, in nearly all cases from the districts near the Firths of Forth and Tay, where the rainfall during the early part of the summer has been less than in most parts of Scotland. Over a considerable part of the area heavy rain has fallen since the beginning of the week, and we hope to hear that it has interfered with the ravages of the caterpillar."

On July 24, Messrs. Drummond further mentioned: "Additional specimens have reached us this morning, and we hear that there are slight attacks in our own neighbourhood." A communication sent by Messrs. Drummond, of Stirling, to the *Stirling Journal* of July 24, gives another locality, and is of interest also as mentioning

<sup>1</sup> Reasons for this are given under replies referring to effects of nature of land.

<sup>2</sup> White Moths.—The different colours and patterns of moths and butterflies are given by small coloured scales on their wings—the powder, as it is often called, which remains after carelessly rubbing one of their wings on the fingers. These scales are very easily rubbed off, and when the specimens are old, or have been packed so as to shake about, it may very likely chance that nothing but the whitish membrane of the wing remains, and the moth to a general observer would appear to be white.



hot sunny weather preceding the appearance of the infestation. Specimens received from the neighbourhood of Arbroath, of yellows just singled, and of swedes almost meeting in the drills, exhibited leaves almost riddled into lacework. A week ago, no one had recognised the evil, and now large fields are being resown. The hot sunny weather of the early part of the summer probably afforded the favourable conditions which led to this plague.

Mr. David Crole, Junior, writing on July 24 from Letham, Leven, N.B., reported that within the last few days the turnip crop on the farm had been attacked by the diamond-back caterpillars and the leaves stripped and holed.

On the following day Mr. John Beveridge, writing from Kinnes-ton, Leslie, Fife, also forwarded specimens of the same species of caterpillar, and requested information as to means of remedy, with the remark that he had twenty acres of turnips that seemed all right a week ago, and now the plant was riddled and seemed in a few days as if it would be entirely destroyed.

Mr. George Dun, writing on August 3 from Easter Kincauld, near St. Andrews, mentioned that he had fifty acres of turnips badly eaten by the caterpillars. Writing again on August 8, Mr. Dun further mentioned that he noticed his turnips were attacked three weeks previously, and the moths in droves, and that on the preceding Wednesday (August 5) he again saw a large number of moths, but not so many.

The following notes were forwarded me on August 19 by Mr. John Duncan, of Kirkmay, Crail, Fife, N.B., and are of much interest regarding plants, retarded in growth by drought or other causes, being more susceptible of injury from the caterpillars than those in vigorous health.

Mr. Duncan wrote as follows: "In this district (East Neuk of Fife) the weather has been very dry, there only having been 6½ inches of rain for the first six months of the year. In July, when the moth and caterpillar appeared, the turnips were at a standstill for want of moisture, and I am of opinion that to this cause alone can be attributed the attack, as vermin of some sort is sure to attack a plant if it is unhealthy or not growing. As an example, I have a field of swedes on cold-bottomed land which had never stopped growing, and have therefore scarcely been touched except on the two end ridges where the crop was not so vigorous, whereas another field on very dry light land has been considerably damaged. Again, six miles westward, where there has been more rain all the season, the damage is not so great as in this corner. The moth is still very plentiful, but as we have now had rain I do not fear a second attack. I have often observed the same moth in previous years in walking through old pastures and at sides of roads, hedges, &c."

*Forfarshire.*—On application to Mr. James Swan, of Inverpeffer, Carnoustie, county Forfar, N.B., who, if not the first to suffer under the outbreak of diamond-back caterpillar, was, I believe, the first in the county to note the sudden attack, I was favoured with the following observations: "We left off working—i.e. hoeing—yellow

turnips, on Tuesday, July 14, in a field, fearing nothing except that we were parched with drought. I was absent for two days till Friday, July 17. On Tuesday evening neither I nor any of my workers saw any sign of danger or damage; on Friday morning not a single plant in ten acres was safe—all the leaves like lace. The next field over the wire fence was swedes begun to meet in drills, and the large broad luxuriant leaves were a pitiful sight, and in both fields the caterpillar was in millions, and there were evidently two broods at work, one  $\frac{1}{2}$  to  $\frac{5}{8}$  of an inch long, thickness, a knitting needle, the other  $\frac{1}{4}$  to  $\frac{3}{8}$  inch long and small in proportion. In this field of swedes, twenty acres, two acres had been sown a second time with yellow seed; and they grew so rapidly as to be thinned on the seventeenth day after seeding, the quickest in my experience in fifty years. In forty-eight hours not one plant left alive. Westward Ho! was the word, and passing two fields of wheat entered on twenty acres saved, and these were so extra luxuriant that the moth failed to do so much damage, but six acres yellow in west of same were all but killed; they are only now recovering. This evening I find a late division of  $9\frac{1}{2}$  acre yellow, all thinned a fortnight ago, not 100 plants left, re-sown a week ago with rapeseed between the rows of turnips, so that, should the turnips perish, the rape would be well started, and I have to report a fine braird of rape growing everywhere, whether sown over and among moth-eaten yellows, or where yellows are clean away."

*Aberdeenshire.*—On July 31, specimens of caterpillars, with attacked turnips, were forwarded to me from the Estate Office, Haddo House, Aberdeen, by Mr. George Muirhead, agent of the Earl of Aberdeen. It was mentioned that the turnips were first found to be affected by the attack about ten days previously, and that five of the six acres of the field in which they first appeared had been completely eaten up so far as the leaves were concerned.

On August 3, Mr. James Harper, of Auchnabo, Slains, Ellon, Aberdeenshire, mentioned the caterpillar had done him extraordinary harm, and nothing did so well to get rid of it as a severe storm of wind and rain from the north, after which the pest almost disappeared.

*Island of Islay, N.B.*—Early in August, observation of diamond-back attack was published as having appeared in Islay, and on making inquiry I was favoured on August 11 with the following reply from Mr. R. Scot Skirving, of Foreland House, Islay, N.B., who also furnished me with corroborative specimens. "I have to-day seen a local farmer, and he says it has rapidly spread over the whole island of Islay, its ravages being very severe in some places and very slight in others. All I have personally seen are near the seaboard by the Atlantic, and it certainly is worst there."

The following communication regards appearance of the diamond-back attack in the Island of Jura, which lies N.E. of Islay on the west coast of Scotland. Mr. Thomas Fraser, writing from Ardfin, Jura (by Greenock), N.B., on August 21, mentioned: "It came on our turnips (at least we observed it) the last days of July.

For the first few days we were a little anxious. The crop was well forward, and as soon as the rain and cool weather came the moth grew weaker, so much so that we did not apprehend any serious damage from it for this season." "The leaves, however, of swedes, yellows, and field cabbage are riddled with their work," *i.e.* work of the moth in first stage, or caterpillars."

## IRELAND.

On August 14, Mr. John H. Franks, Secretary, Irish Land Commission, Dublin, noted in a letter on other business: "You may be interested to know that the diamond-back moth has appeared in many places in Ireland, especially along the Eastern coast."

A few days after, on August 17, specimens of swede leaves from Dunany, Dunleer, co. Louth, were sent me by the Editor of the *Farmer's Gazette*, Dublin, for examination. These showed unmistakable signs of diamond-back caterpillar ravage, and characteristic cocoons were also sent, but the caterpillars were too much injured to be quite surely recognisable. I therefore requested further supply of specimens, and, on August 22, was favoured by Mr. W. J. Bloomer, Land Steward, Dunany, Dunleer, co. Louth, with excellent specimens, both in caterpillar and chrysalis state, of the diamond-back attack, with the following note:—

"I am requested by the Editor, *Farmer's Gazette*, to send you box with a small quantity of the moths, supposed to be the 'diamond-back moth,' which have done so much damage to my turnip crop this season, but am happy to be able to say that the worst is over, as the heavy rain of the past ten days (which was the heaviest rain I have experienced for a great number of years) did a good deal to stamp out the pest; for had the weather continued dry up to now, I wouldn't have had a turnip left in the field; and especially the younger ones, a great number of which were completely devoured, where the stronger ones only suffered from small holes through the leaves. I am happy to say that, after the heavy rain yesterday, it took some time this morning to collect the small quantity sent you. My turnip field is only a short distance from the sea, where it seems we have suffered most, as I was speaking to some farmers from the midland counties of the north, but they don't seem to know anything about the little moth they have heard so much talk about.

"I tried the experiment of the small knapsack spraying machine, paraffin oil, and soft soap, under the direction of Commissioner Wrench, Irish Land Commission Department, which, I believe, had a good effect, but with heavy rain at the same time, I hardly know which to give the most credit to. I am thinking if another season brings down the army of little diamond vipers upon us, I will try to fight them in this way:—I will get a hose attached to my water-cart, and continue to dash the water over the turnips in the form of a heavy shower; this I will continue until all the moths are washed off, same as I see the heavy rain has done in the present case."

The above notes, it will be seen, coincide with the main points of

the English and Scotch observations. The attack appeared near the sea-coast, was most injurious to the weakest plants, and its effects were checked best by heavy rains. Probably Mr. Bloomer's simple plan of dashing water at the plants by means of a hose would be thoroughly serviceable.

*Appearance of moths in great numbers at various localities on the eastern coast about the end of June, and considerations pointing to the probability of the infestations having been blown across the ocean from the Continent.*

On August 4 Mr. John E. Robson, of Hartlepool, Fellow of the Entomological Society, and Editor of the *British Naturalist*, described, in a letter sent by him to the *Newcastle Daily Journal* (published on August 6), the enormous quantity of the *Plutella crucifera*, or diamond-back moth, which had suddenly appeared at Hartlepool on June 24, together with some other points which, coming from a skilled entomologist, used to identify species and observe habits, were very valuable, as they proved almost beyond possibility of doubt that these vast numbers of moths were not developed on land, but had been wind-borne from the continent of Europe.

On application to Mr. John Robson he was good enough to write me more in detail as follows: "As stated in the letter, I was collecting at a little distance from the coast on the evening of June 24. On my return home my son gave me a specimen which he had caught in the tennis court, and he described the numbers there as being beyond all he had seen before. They were everywhere and in large numbers. At night I crossed the 'coal staiths' for a short cut, to where I wanted to collect; they were there in thousands,—sitting on every coal waggon, on every bit of iron railway plate, on the wooden palings, and rising like a cloud at every step."

Here Mr. Robson gave me long details as to what kinds of plants grew in the neighbourhood (where there were any at all), and of amount of town land, showing that it was absolutely impossible that the moths should have been bred where they appeared.

The moths, Mr. Robson observed, appeared on June 24, and did not increase in numbers, but in unsuitable places, such as Hartlepool, they disappeared in two or three days, whilst further away a very small number remained on the coast edge, but they gradually spread inland.

In his published letter Mr. Robson shows something of rate of progress by mentioning that on the day of appearance at Hartlepool he found none at Hezleden Dene, about one and a half mile from the coast, and on June 26 they were swarming at this locality, having penetrated thus far in two days.

Mr. Robson also brought forward the further considerations: "(1) For a long time previous to June 24 easterly winds prevailed, which would greatly assist the moths in crossing the sea. (2) The impossibility of so large a number of the insects passing through the larval stage without being observed by either farmers, gardeners, or

entomologists. (3) Their appearance in such abundance in places like Hartlepool, where there is no food at all for the larvæ. (4) The fact that their ravages were confined to the seacoast or to a restricted distance therefrom. (5) The fact that on June 24 the species appeared simultaneously in many places."

Mr. J. Burdon Sanderson, of Waren, Belford, about two miles from the coast of Northumberland, wrote me as follows: "My own opinion is that the moth came from abroad somehow or other, as the easterly winds were blowing steadily for some weeks, and the attack seemed to be along the coast and up the Tweed. Whether this is possible or not, I do not know. My brother-in-law at Chatton, seven miles inland from Waren, saw an immense quantity of dead moths along the road extending for some half-mile, evidently killed by a heavy shower which had just fallen. This happened just before the attack was noticed, and nothing was thought of what was to follow. Since writing the above, I have just heard that on the night of July 9 an immense cloud of diamond-back moths alighted on the Longstone, the farthest of the Farnes, some five miles out to sea; this is on perfectly reliable authority, and seems to favour the theory that they come from abroad."

This appearance of diamond-back is confirmed by published information from Mr. H. A. Paynter, Solicitor, Alnwick, who mentioned that, being requested by Lord Walsingham to try to get him some moths, he, Mr. Paynter, proceeded on July 10 to the Longstone Lighthouse on the Farne Islands, where he found the rocks close to the lighthouse covered with them. The lighthouse keepers informed him that on the previous night such a great cloud of moths was driven over by the north-east wind that they were obliged to keep sweeping them off the lantern throughout the night in order to allow the light to be seen at sea. Mr. Paynter sent some of these moths to Lord Walsingham (who, it may be remarked in passing, is a highly skilled entomologist), who identified them as "diamond-backs."

The chief points of the above appeared in various papers. I quote from the *Agricultural Gazette* for August 24, 1891.

Mr. Fenwick Wilson, of Marden, Whitley, also not far from the Northumbrian coast, mentioned: "A common opinion exists in this neighbourhood that the moth crossed over from the continent. Some fishermen I have spoken to say that about the end of June moths were about the shores in enormous quantities, and were spoken of by them at that time. If it is possible for them to come from abroad that very much supports the theory."

Further north still the observation of a vast appearance of moths on the sea coast was thus reported by Mr. Balsillie, of St. Andrews, Fife: "On the last days of June an extraordinary number of small greyish-brown moths were observed all along the eastern seaboard of the county of Fife infesting the turnip-fields. Their appearance was coincident with a long-continued drought, and though the plants had braided, they were making exceedingly little progress. On Monday, July 20, or as nearly as may be three weeks after the

appearance of the moths, both swede and yellow turnips presented the appearance as if lime had been sown on them. On looking more particularly, it was found that the plants were infested with small green caterpillars which had eaten the underside of the blade, leaving the thin film on the upper surface. In this way whole fields were destroyed. In other cases portions of a field seemed to escape with comparatively little damage.

In the following pages the information given me in reply to my circulars is divided and classed for convenience of reference under the various headings to which the observations refer, the initials of the sender being appended.

In the return immediately following, as conditions affected by geographical locality would affect the state of the crop, I have arranged the notes, as before, under headings of countries and counties. The subsequent observations are arranged alphabetically according to the initials appended.

1. *Any estimate of amount of loss, whether in acreage, mileage, or money loss on crop.*

#### ENGLAND.

*Yorkshire.*—"In this district (Lebberston, near Filey) the caterpillars have ruined the swede crop; there will be only half a crop. Turnips have not suffered nearly as much."—J. P. D.

"In some localities [of the chief turnip-growing districts in Yorkshire.—E. A. O.] the turnip seems nearly worthless, in others half a crop, and the best where attacked, I should consider, will only make two-thirds."—G. C.

"I have had no root-crop quite destroyed, but the estimated produce per acre of kohl rabi has been lessened 75 per cent., swedes and white turnips 50 per cent., and yellow turnips 25 per cent. Mangel quite untouched."—R. W. S.

"Damage slight at present; impossible to estimate."—F. R.

"Loss on swede turnip crop about one-third the white; green top and Lincolnshire red turnips have not been affected by the moth."—R. C., for Lord Auckland.

*Lincolnshire.*—"Swedes damaged greatly here (between the river Ancholme and the Trent), probable loss of 50 per cent. of resulting food. Five per cent. of swede area only totally destroyed. White-fleshed varieties not much damaged here (oolite), but much so on the Wolds" (chalk).—N. Lincs.

*Norfolk.*—"Loss from this attack very considerable, especially near this coast, N. and N.W. Norfolk, where both cabbages and turnips were attacked."—E. A. A.

"In early sown turnips the loss in yield is about 25 per cent., in later 15 per cent."—C. R.

*Norfolk and Suffolk.*—"So far as Corton and Whitlingham are concerned, taking the swede crop (which is the only one injured) at 6*l.* per acre as the maximum value of a full well-grown plant of

swedes in Norfolk and Suffolk at Michaelmas valuations, the greatest part of the Corton crop was entirely destroyed, while the remainder, (with the exception of one piece which was sown very early, and appeared to have been too forward for the caterpillar to attack) cannot be more than one-third of a full crop under the most favourable circumstances. While the Whitlingham crop, being attacked about three weeks later than Corton, the heavy rains coming at the same time, washing in a good dressing of nitrate of soda and salt, appears to have at once stopped the ravages of the pest, but not before they had checked the growth of the plants, so that under the most favourable circumstances there cannot be much more than half a crop."—G. T.

*Cheshire*.—Near Sandbach. Estimate of loss per acre 10*l.*—S. S.

*Lancashire*.—Lytham. Three statute acres have been rendered quite useless.—T. F.

*Northumberland*.—"In some cases in the district round Bam-borough the loss is the whole crop gone. I can hardly tell yet what loss I have sustained in my turnips, as I hope they are coming round."—J. B. S.

"Thirty acres of turnips and swedes affected to the average amount of 5*l.* per acre."—F. W.

"I have suffered no loss as I took means to remove the caterpillars before they had time to do any damage, except making holes in the leaves in some parts of the field."—W. P.

#### SCOTLAND.

*Fifeshire*.—"Evidences of the ravages of the caterpillar may be seen at least six miles inland, and I should estimate that from a third to a half of the crop had been destroyed."—A. B.

"Crops which were far on have suffered very little, while those which were later in the same district, and even on the same farm, have been almost, and sometimes totally, destroyed; so that an estimate of loss is at the present time impossible. A 43-acre field of swedes of mine looked miserable about the end of July, but now, having been top-dressed with nitrate, and pushed on by moisture and heat, it is looking, except in a few spots which were badly bitten, a very fine crop."—J. A. B.

"Cannot give an estimate of my loss further than to say that it has made my crop, where affected, four weeks later; but on a farm in this neighbourhood" (East Neuk of Fife) "one-third of the crop is almost destroyed and part ploughed up, and the other two-thirds are much affected."—J. D.

*Fifeshire*.—Estimate of amount of loss about one-fifth [report applies to the north of Fife—E. A. O.]. "Turnips have improved very much of late, and it is difficult to estimate the loss, as so much depends on the future, and whether or not we have early frosts. Land in the highest condition and properly cultivated has suffered least."—D. C.

"It is only in certain farms where whole fields have been destroyed, and in the majority of farms in the east of Fife the

damage at the time looked to be more severe than it will now be, owing to the fine growing weather which has forced the crop away beyond the power of the caterpillars. I should therefore say that the damage done will not amount to the fourth of the whole crop—nearly this.”—J. L.

“I can form no estimate as yet as to the loss, the turnips are growing so fast now that they may be a fair crop yet, except about one acre out of twenty which is totally eaten up.”—J. B.

*Forfarshire.*—“Over an area of 30 acres swedes 25 to 30 per cent. of deficit must be recorded; and over 30 acres yellows 15 are a total loss, and only rape instead of the other 15 may make 50 per cent. of average. The *money loss* cannot at this early date be accurately recorded.”—J. S.

*Aberdeenshire.*—“Twenty-four acres more or less destroyed, about 10 acres totally destroyed to the value of 100*l.* Fourteen acres estimated destroyed to about 3*l.* to 5*l.* per acre. This near Slains.”—J. H.

*Lanarkshire.*—“Loss in locality (neighbourhood of Glasgow) comparatively speaking *nil*. Most crops of swedes contain a few caterpillars, but damage has been confined to very small patches or holes in the leaves, entire stripping of the leaves being very exceptional.”—J. S.

SUMMARY.—The above notes (for the most part) only give a general estimate of damage from inspection of condition of crop at time of report. Where it has been wholly swept off the amount of damage is plain, otherwise so much depends on the weather of the coming autumn that no certain return of amount of loss can be now given.

The observations, however, show the ruinous character of the infestation. It will be seen that the amount of damage at date is estimated by various observers as “considerable”; “half a crop”; “nearly worthless” to half or two-thirds only being expected; crop lessened 75 per cent. or 50 per cent.; a third gone. In money estimate we have notes of 30 acres affected to the extent of 5*l.* per acre; and another return of loss of 10*l.* per acre; another observer notes the very important item of crop being thrown four weeks later. And to this has to be added the coming losses consequent on failure of one item in agricultural routine, especially in reference to food for sheep and lambs.

2. *Any measures found to answer in lessening amount of ravage, or loss from its effects.*

“Soot and also superphosphate have been used apparently with good effect.”—E. A. A.

“Soot and nitrate of soda have both been freely used in this district (near St. Andrews, Forfarshire), but I am doubtful if either had much effect upon the caterpillar. The remedy was attempted too late, in fact just at the time the caterpillar was spinning its cocoon. Beneficial, however, to push the plant into more vigorous growth. In other cases scufflers with boughs were sent through the fields.”—A. B.

“I put on about 1 cwt. of nitrate and 1 cwt. of salt per acre. I



do not think this had any direct effect on the caterpillars, but has helped the turnips very much. We have also been hand- and horse-hoeing as close to the turnips as possible."—J. B.

"I sowed 1 cwt. per acre nitrate of soda on 43 acres swedes and 10 acres yellows, and 2 cwt. soot on 1 acre swedes. All have come away well, and done better in resisting or rather overcoming the damage than what was not top-dressed. Scuffling I think has helped crops which were far on by rough disturbance of the leaves."—J. A. B.

"Nitrate of soda, &c. have been very beneficial; do not know of other remedies having been tried in this district."—D. C.

"My son, on a farm of Lord Londesborough's, tried nitrate of soda with better result by far than his neighbours, who used soot, lime, and other manures."—G. C.

"The best mixture we used was 10 cwt. soot, 8 cwt. nitrate of soda, with 1 cwt. sulphate of ammonia, mixed well and sown broadcast by hand, whilst the *dew* was on the leaves, 1 cwt. per acre; we also used scufflers with boughs on them through the crops; also we tried quicklime, gaslime, soot in equal parts, 1 cwt. per acre, with 3 lbs. yellow flowers of sulphur added per acre, but the first mixture proved best in checking the spread of the moth."—R. C., for Lord Auckland.

"I have tried no fertilisers, but have no doubt but that nitrate of soda would help to push on crop and thereby lessen the amount of damage. On a light-land farm of mine in the next parish, my grieve tied boughs to the *front* of a horse-hoe and brushed off numbers of caterpillars, and the tines coming after buried them in the earth. The fields so done have not suffered much."—J. D.

"The method I found to answer best at the least cost was using a scuffer with thorn boughs attached in front, and set so as to turn the leaves completely over; by so doing it broke the webs and let the caterpillars down, and the scuffer buried them."—J. P. D.

"All the remedy I made use of was to keep going all the horse-hoes and scufflers I had all day long. One of my neighbours tried trailing a sheep net across his turnip field and then sowing lime, but I do not think that his field has recovered more than mine; he also had a net hanging on his larger horse-hoe trailing on the plants before the knives; this acted well, but the pest was about over when he tried this."—W. F.

"Tried hot lime, also paraffin and soot, and none of them appears to do good, as the caterpillars are fairly secured below the leaves. The scuffling of the plants destroys them very much."—J. H.

"Brussels sprouts attacked. *A part* syringed with a preparation of soft soap and paraffin, five pounds of former and five pints of the latter to 100 gallons of water—result, caterpillars destroyed. *Remainder* soot scattered on the under side of leaves—result as above."—M. K.

"Several farmers have put in boughs of trees in the scufflers. I put in my ploughs a good firm bundle of wheat straw bent down at the ends, so as to rub the under part of the leaves without damaging

them, as the boughs are apt to do. No one that I am acquainted with has applied anything but nitrate of soda—not with the idea of killing the caterpillars, but to force the growth of the turnip. So far as brushing them is concerned, I find they again ascend the turnip from the ground, and if buried under three inches of earth, at once find their way to the surface.”—J. L.

“In my case nitrate of soda has given vigour to the plants, this doing good. Friends report boughs on scufflers advantageous.”—“N. Lincs.”

“By keeping the scufflers going with birch branches attached. I had dusted with quicklime on the under side of the leaf, it did not kill them; going back next morning I found they had eaten part of the leaf, lime and all, and were still as lively as possible. I also tried paraffin and water, 1 to 50, put on by a garden syringe with a very small rose; the only effect I could see it had was keeping the birds off that part of the field.”—W. P.

“Damage was done and caterpillars had disappeared before it was known what they were, hence no measure was taken to destroy them.”—F. R.

“The insects lying very lightly on the leaves, brush harrowing once lightly would remove them, and the Strawsonizer with paraffin would, I think, be thoroughly effectual, but as the action of the caterpillar is *very rapid*, careful observation and instant action on their appearance is imperative; if no Strawsonizer available, repeating the brush harrowing would, I think, answer equally.”—C. C. R.

“Nitrate and super—the best stimulants, and unfailing in good results—no dry or dust application, nor any chance of Strawsonizer or sprayer. But practically over sixty acres *no lime* or water or machines to overtake the work.”—J. Sn.

“I applied quicklime by hand on a windy day, as the wind was blowing up the drills; the lime got well under the plants and stuck to the leaves, covering the under sides well; this did not kill the caterpillars at all, but I think rather prevented their working, and I hope checked them in spinning cocoons. I top-dressed the worst with nitrate of soda, which stimulated their growth and thus helped them, but what certainly did most good was scuffling with light branches fastened across the scuffler. I consider the best treatment was to keep constantly working among the turnips, scuffling or running the small plough between the drills. I saw paraffin oil applied on another farm, which I believe did little or no good; a mixture of arsenic and lime also applied with the Strawsonizer apparently killed the caterpillars, but I did not see this done myself, so I cannot speak positively about it.”—J. B. S.

“I tried 5 cwt. of dissolved bones per acre, put on each plant by hand, without effect; before applying the bones I tried sulphur and lime (after scuffler with boughs on), fumigation with sulphur, Paris green mixed with water, and Little’s non-poisonous sheep-dip, all likewise without effect.”—R. W. S.

“Nitrate of soda at the rate of 2 cwt. per acre as a top-dressing

to push forward the growth of plants is, I believe, very beneficial ; it acted well for our turnips."—S. S.

"Nitrate of soda and salt about four stones per acre of each, sown down by hand along the drills, was very effective in setting the plants growing, and a scuffler fitted with boughs was tried at Corton and answered very well indeed ; as also did four to six gallons of paraffin per acre applied with Strawsonizer. We should have tried soot and lime had not the ravages been stopped, should also have walked a flock of lambs backwards and forwards over the plants, which I believe would be very beneficial and would act as a scuffler would, and not injure the turnips."—G. T.

"Only measure taken was heavy dressing with salt sown broadcast, which did not appear to do any good."—F. W.

"Where stimulating manure (nitrate of soda) has been applied swedes appear to have more vigour after severe attack has passed away ; not tried any spraying."—T. H. W.

SUMMARY.—In the foregoing observations it will be found that the remedies most approved of as satisfactory are nitrate of soda, and use of scufflers, or of horse-hoes. Nitrate of soda, whether by itself or occasionally together with soot and salt, is repeatedly mentioned as having been beneficial. Salt alone is noted as having done no good, but the fertiliser far more named as beneficial than any other is nitrate of soda—and in some cases it is explained that the benefit is not from any known action on the infestation itself, but by keeping up the growth of the attacked plants.

The use of the scufflers has also been found very serviceable, and on similar principles the horse-hoes have been found beneficial by passing them through the turnips with light boughs, or in one case a net attached in front ; the caterpillars are so disturbed that many fall and many are destroyed, and the use of a plough with a bunch of wheat straw, fastened so as to sweep the leaves before it, has also been useful. Other applications are slightly alluded to, but the above are what are chiefly reported as beneficial.

### 3. *Opinions as to benefit of heavy rains.*

"All the early-sown turnips attacked by these caterpillars have undoubtedly much benefited by sudden and heavy rains. In one field at Thornham (Norfolk), on which the attack was bad, scarcely a living caterpillar could be found after two days' heavy rains."—E. A. A.

"We were certainly fortunate at the time the attack was worst in having heavy rains."—A. B.

"The heavy rains we have had have done more good than anything else. Even first showers after the attack began had a wonderful effect. My neighbours all concur in this opinion."—J. B.

"Heavy rains marked the first symptoms of a stoppage of damage, but I think high winds and a lower temperature on the night of July 22, and during the last four days of that month, were also of great benefit."—J. A. B.

"Heavy rains and cold nights did universal benefit."—D. C.

"The heavy rains have been very beneficial, especially where the nitrate of soda mixture was used."—R. C., for Lord Auckland.

"Heavy showers, with an extremely low temperature on July 28, destroyed great numbers."—J. D.

"The heavy rains we had a week ago did an immense amount of good, splashing the soil on to the under side of the leaf, and either drowning them or settling them away."—J. P. D.

"The leaves up to about ten days ago [before Aug. 13—E. A. O.] had been eaten quite bare; but after the heavy rain-showers of last week they grew again."—T. F.

"The rains have done good in encouraging growth of the turnips, as had it been excessively dry the plants must have died."—W. F.

"We had two wet cold days with high winds, and thereafter I think the turnips were much clearer, and the caterpillars which were left had not such a high vitality, and the crop appeared to be improving."—J. G.

"I have no doubt that the weather does more to check the attack than anything you can do. We had a week of very stormy weather, and it almost cleared the plants."—J. H.

"It is believed that the heavy rains have been chiefly instrumental in clearing caterpillars."—M. K.

"I do not think rain has any effect in killing them."—J. L.

"The benefit of heavy rains was so great that no further measures were needed to get rid of the caterpillars."—G. M.

"Heavy rains, 1.73 in. and 2 in., have done immense good, and caterpillars now gone."—"N. Lincs."

"The cold weather and heavy rains we had, during the week ending August 1, killed great numbers."—W. P.

"Rain appeared to stop ravages when accompanied by wind."—F. R.

"Heavy rain did most good falling on dry parched surface, dashed the sand and mud on the under side of leaves, and made the life of the caterpillar no sinecure."—J. Sn.

"Rain did not kill, or even wash off the caterpillars in my case, but as it kept the plants growing to a certain extent it did good."—J. B. S.

"I think that heavy rains do good by 'soiling' the under sides of the turnip leaf, and making it rather difficult for the caterpillar to work; also by alarming them, or washing them off."—R. W. S.

"(August 11.) I am informed that recent heavy rains have done much good, and, as a whole, the promise of the turnip crop in the island is a very good one." On August 13 it was further reported: "As rain at last came after months of drought, I do not think the crops will suffer."—R. S. S.

"Very heavy thunder-showers might shake the leaves and cause the caterpillar to fall to the ground, but I believe a good strong wind would disturb the plants a great deal more so, therefore would make it more difficult for the caterpillar to hold on to the leaf, and a fluid dressing of soot and salt would, I think, destroy the pest, and be a good fertiliser."—S. S.

"Every benefit to be derived from heavy rains ; in fact, I much question whether the pest could be entirely destroyed by any artificial means without them."—G. T.

"Caterpillars appeared during very dry weather, which was followed by very heavy rains and thunder-showers, but they had no effect on caterpillars, which, in fact, did most harm during, and immediately after, rains."—F. W.

"Heavy showers undoubtedly have done good."—T. H. W.

SUMMARY.—With only two exceptions, the above observations concur in the beneficial effect of rain in checking the caterpillar attack, especially when accompanied by a drop in the temperature, and by high winds. A large part of the good done is presumably by the moisture in the air and *at* the roots helping on growth, but the winds and chillier weather would be directly injurious in some degree to the caterpillars.

Cold rains in warm weather have been known in some cases to be rapidly destructive to caterpillars, by causing a flux which soon reduced them to empty skins, and the following few words with which I have been favoured from Mr. Thos. Fraser point so forcibly to something of this kind having occurred to the diamond-back caterpillars under his observation that I give his remarks separately.

Mr. Fraser, writing from Ardfin, Island of Jura, by Greenock, N.B., on August 21, mentioned : "I observe that the moth is decaying or dying in the first stage now ; no doubt the result of the heavy rain we had recently."

#### 4. *Nature of land, how cultivated, and what manure was used.*

"At Thornham the soil is fairly good, bright, and light, with chalk about two feet below. Land ploughed about three inches, difficult to plough deeper there ; no manure used."—E. A. A.

"In some cases whole fields were destroyed ; in other cases portions of a field seemed to escape with comparatively little damage.

"On inquiry into the reason of this, it was at once apparent that it depended to a great extent on the nature and condition of the soil, and the state of plant-growth at which attack commenced.

"Early-sown turnips in good soil, both as regards mechanical and manurial condition, survived the attack and continued to grow, while on hard clay soils, and on back lying soils trending to the north, and where the attack had commenced shortly after or during thinning, the plants were entirely eaten up.

"There is no doubt that the best preventive is to have the land in high-class condition. In a field, for example, which was well done to, a portion which got an extra dressing, from the more vigorous growth of the plant, seemed almost to have escaped."—A. B.

"The land is alluvial deposit and sand. I farmed part of the old bed of Loch Leven. It was five years in grass, oats last year, and was ploughed in December rather wet, and not trenched again till June 1.

“The turnip soil made with farmyard manure, and about 5 cwt. of nitrate of soda and super—no salt.”—J. B.

“Land : generally black loam or whinstone ; some fields on sand, late sown, were worst. No difference observable to any extent in time or manner of ploughing. Manures : nitrate of soda, guano, Liebig’s meat meal superphosphate, bone meal and flour, some cases kainit, no salt.”—D. C.

“I travel through the greatest turnip district in Yorkshire weekly, and observed the ravage of the pest very minutely. I found it to vary very much, affecting the plant more on flinty soil on the wolds than chalk. Also on low lands where there are different kinds of soil in one field, say strong gravel and peat, affecting the gravel and peat, and leaving turnips on strong land very little hurt.”—G. C.

“Land sandy. Autumn cultivated ; we clean the land after wheat, plough deep three times by crossing, then ridge ; farmyard manure, twelve to fourteen cartloads per acre, with no artificial manure, or six cartloads farmyard manure, with 3 cwt. dissolved bones per acre, or the same quantity farmyard manure, and 4 cwt. concentrated manure per acre.”—R. C., for Lord Auckland.

“Attack noticed on July 17, in 25-acre field of swedes, lying 20 feet above sea level, within 500 yards of the river Eden, where the tide rises to daily, heavy loam in high condition. Sandy subsoil, 14 acres dunged in the winter, remainder in the drill, also treated with best herring guano, superphosphate, and nitrate when the land was drilled with turnips. On July 20 (that is, after attack was observed) whole turnip crop of the farm dosed with dressings of superphosphate and nitrate, sowed with two hands taking two drills at a time, so as to protect the heart of the turnip from the caterpillar. Dressing, with the help of heavy thunder-showers, appeared to start growth, and on the 27th, turnip showed decided improvement.”—G. D.

“As said before, crops on dry light land suffered most ; the land was ploughed in autumn and early winter, and worked and cleaned before seed-time. The same manure was used for all turnip crops, viz. farmyard manure, Ichaboe guano, and superphosphate of lime.”—J. D.

“Our land is light wold land on chalk, but the attack was just as bad on both sand and clay. Two fields of mine were autumn cultivated, and one simply ploughed in the usual way. Kainit was used (but no salt otherwise) with bone manure.”—W. F.

“The land is strong black land with a subsoil of white ore ; it was ploughed in the autumn to a depth of about 9 inches ; the field had a light dressing of ordinary farmyard manure, and 1 acre had 2½ cwt. of dissolved bones.”—T. F.

The following observation is well worth notice with regard to *non-injury* to the caterpillars from being buried for a while together with the leafage, which would both protect them from injury and serve them for food. “I put on the setting-up ploughs, and entirely covered up the turnips that I could not overtake. [This was during experiment on badly-attacked crop—E. A. O.] This I did in fair desperation. After being buried a few days, I put on the

scufflers to level down the earth ; then the field workers with hoes to uncover the blades or leaves of the turnips. When uncovered, the leaves that had been buried showed the caterpillars upon them *quite lively*, when I expected they would have been dead.”—J. G.

“Good black land in good heart is free from attack. Heavy clay land is destroyed a good bit, especially where it is of a wet nature. Light mossy land with a little gravel through it is entirely destroyed ; nothing left but a few stumps. Manure used : about 20 square yards of good farmyard dung with about 10 cwt. manure, composed of three parts dissolved bones, three superphosphate, three sulphate of potash, and one nitrate of soda ; the land was heavily ploughed.”—J. H.

“The land on which the turnips are worst is generally stiff but not always, and those fields which are destroyed are generally those which are not in a thriving state when they are attacked. The depth at which the land in Fife is ploughed in stubble is from 6 to 8 inches ; the manure used is generally half dung and some light manure. No salt.”—J. L.

“Oolite and on clay, worse on clay ; autumn cultivated and ploughed 6 inches ; 1 cwt. bone dust, 3 cwt. mixed phosphates.”—“N. Lincs.”

“Part red clay, but mostly whinstone gravel ; all the land I have turnip this year (100 acres) has been limed within the last four years at the rate of 7 tons shell lime per acre. All my turnips are after oats. The land was all ploughed during autumn and early spring about 10 inches deep ; it all had two furrows, just before sowing. Thirty acres of swedes had fifteen loads farmyard manure, 5 cwt. Thomas’s phosphate powder, 2 cwt. kainit, and 1 cwt. nitrate of soda put on the ridge and split in just before sowing ; 10 acres had the same quantity of farm manure ploughed in during autumn, also the same artificial per acre, and the ridges split before the seed was sown. After having the caterpillars brushed off, I top-dressed the whole with  $\frac{1}{2}$  cwt. nitrate of soda and 2 cwt. salt per acre. Now it is scarcely possible to tell anything has ever been on them, they are looking so well.”—W. P.

“Fine alluvial, deep and lightly ploughed in different parts ; superphosphate and salt used.”—C. C. R.

“Clay loam, previous crop oats, deep ploughed in autumn shortly after harvest, crops ploughed end of January and twice afterwards. Superphosphate only used, no salt or farmyard dung.”—F. R.

“My land all natural turnip land, some with sand or sandy loams and clay loams. First field attacked was twice scarified in the fall of 1890 and all stubble and weeds raked off ; deeply ploughed 8 inches in February and again in May and dunged in drills. Where rotted dung was applied the plants have outlived the attack ; where courtyard dung, fresh, the plants all perished.”—J. Sn.

“Fine loam.—In one field I had rather a good instance of cultivation, as out of the field (which is about 3 acres) 2 acres were not ploughed till just before sowing swedes (the field had been oats) ; the rest was ploughed in winter ; the caterpillar was equally bad on both bits where swedes were sown, but hardly did any harm to a

strip of early-sown yellow turnips between two lots of swedes. Manure used, farmyard and fish phosphate. The oat stubble was ploughed about 8 inches deep, and was twice ploughed again before drilling."—J. B. S.

"Clay loam. Not autumn cultivated. Ploughed deeply in autumn and twice in spring. Half of kohlrabi was farmyard manured, but no difference is to be seen between the manured and unmanured parts. Dissolved bones and half-inch bones were drilled with kohlrabi and turnips. No salt was used."—R. W. S.

"Nature of land, heavy, strong soil; spade-and-fork culture nearly throughout. Dug in autumn to the depth of 8 or 9 inches, gave part a light dressing of gaslime; the heavy dressing would be at the rate of 3 tons per acre, and the light one  $1\frac{1}{2}$  tons per acre, about December 19. Allowed it to remain on the top until March, and where the heavier dressing was put very little destruction was done by the caterpillars; good litter manure was used at the rate of 12 tons per acre; also specially prepared artificial manure of 5 cwt. per acre; 1 cwt. of salt per acre was part of the artificial manure."—S. S.

"The land at Corton is a strongish top soil on yellow clay, and owing to the exceedingly dry weather up to October, and frost and snow afterwards, was not ploughed or cultivated until latter end of February or the beginning of March, and then only ploughed fleetly. In some cases the manuring for swedes was town manure, fish refuse, with a good proportion of salt mixed up together and put on at the rate of ten loads per acre, while in others 4 cwt. mineral superphosphate and  $\frac{1}{2}$  cwt. nitrate of soda were applied before the attack. At Whitlingham the surface soil is a light soil on brick earth, and was cultivated in the autumn and ploughed a good depth in the spring before putting in the swedes. Some fields were manured with ten loads farmyard manure and others with 4 cwt. mineral superphosphate per acre."—G. T.

"A.—Moderately strong; was deeply ploughed in spring, twice cross-ploughed, and well cultivated.

"B.—Manured with town manure on stubble and ploughed in and heavily manured with fold manure in drills just before sowing seed; no salt used as manure."—F. W.

"Light brown sandy loam, autumn cultivated; ploughed about 7 or 8 inches deep. Manure, bone meal, superphosphate, and slag; no salt."—G. W.

"Friable loam, farmyard manure ploughed under deep in winter; a dressing of 5 cwt. steamed bones and  $1\frac{1}{2}$  cwt. nitrate applied when turnips were sown; no salt used."—T. H. W.

SUMMARY.—In this section it is hardly possible to give a summarised view of the information, in consequence of the various natures and various combinations of the manurial applications, and the various natures of the soils to which they were applied.

It is noticed in some cases that turnips under favourable circumstances escaped with little injury, and several instances are given of those on clay or over strong land suffering; but for practical use the above details would have to be worked out at length by com-



parison with each other, and in connection with the preceding and following observations belonging to the same locality.

5. *Character of weather and nature of weeds.*

"Weather decidedly fine and dry last autumn; lateness in harvest caused difficulty in clearing the land."—E. A. A.

"So far as I have observed there was nothing exceptional in the weather during the autumn to account for the visitation."—A. B.

"From March to June 1 very dry and cold, then very dry and warm."—J. B.

"After the frost of last season the land was in fine order, and turnip sowing was commenced about May 1; with a fair amount of rain in that month, the early-sown fields got well away, though for a time they were kept back by cold east winds. In June we had only 0.28 rain; . . . up to July 15, 0.65 rain fell, but in such small quantities as to do only the growing turnips good. On July 17 and 18 the caterpillars appeared and simply ate up all the weakly plants, which had come away in patches, and did much damage to fields which had stood still in June, not being far enough on in the shaw to catch the rain and hoar.

"Heavy rain on the 21st, 22nd, and a lower temperature marked a change, and by the end of the month the caterpillars were much fewer in number; and now (August 15) are entirely away."—J. A. B.

Accompanying his long and careful report (of which space permits me only to give the main points), Mr. J. A. Begbie (of Queens-tonbank, Drem, Haddingtonshire) favoured me with meteorological returns, bearing serviceably on considerations of weather effects, and amongst these the greater warmth and the absence of any sudden fall of temperature during the nights of July, 1891, are very noticeable as compared with the observations of night temperatures during July in the two previous years, namely, in 1890 and in 1889. In these three years the lowest readings taken of night temperatures were:—

1889, for the most part between	43°	and	51°
1890	"	"	41° " 50°
1891	"	"	46° " 54°

The general temperature at the time of observation was thus noticeably higher in 1891, and in this year it was only twice recorded in the month as sinking as low as 44°.

"Never saw the land in finer condition for the growth of turnips; it was all that could be desired."—G. C.

"Weather was very dry the previous autumn, and the land in this district was especially well cleaned."—R. C., for Lord Auckland.

"Weather here has been exceedingly dry for two years; except on two occasions no water has run off the surface."—G. D.

"Previous autumn wet, but did not interfere with cleaning of turnip break. No particular weed noticeable."—J. D.

"The weather was wet in November, but subsequently very dry."—T. F.

"The weather was particularly dry ; my land was cultivated by steam power. No particular weed observed."—W. F.

"The weather was observably wet in the previous autumn, but had no weeds to clean, so the weeds could have nothing to do with attack."—J. H.

"Here (Branton, Alnwick) we do not clean our land until just before sowing ; the weather at the time could not have been better for cleaning land. I never sowed my land in better order ; they were all sown by May 21, which is considered early in this district. There was no particular weed noticeable."—W. P.

"Previous autumn very wet ; the land was cleaned in spring without any difficulty, and no particular weeds were noticeable."—J. Sr.

"Fine autumn till October 20, after that till December 1 very wet ; no particular weeds."—J. Sn.

"There was nothing in the weather to prevent cleaning the land, which is singularly free from any weed. We had an extraordinarily dry month in February."—J. B. S.

"The first half of the autumn was dry (very) and the latter half was very wet ; no particular weed was unusually noticeable."—R. W. S.

"Remarkably dry winter and spring ; no particular weed."—T. H. W.

"Exceedingly dry up to October, and where stubbles were broken up during harvest or immediately after (before the land got too hard and dry for ploughing), gave farmers a good chance of cleaning the land."—G. T.

SUMMARY.—The above observations show that in some districts autumn or winter weather was dry, in some wet, but this does not appear to have affected agricultural arrangements so as to prevent land being properly cleaned and prepared, nor to have caused any special weed growth, and also does not appear to have affected amount of caterpillar presence.

Where, however, there were heat and drought (as mentioned by Mr. J. A. Begbie in this section, and by Mr. J. Swan on page 609), coinciding with the appearance or observation of the caterpillars, this proved most favourable to caterpillar ravage. These weather conditions were favourable to the grubs and unfavourable for plant-growth ; consequently, until the rains came the plants were almost powerless to restore the devoured leafage.

6. *Whether this caterpillar is found to especially frequent charlock ?*

"The caterpillar of *P. cruciferarum* certainly does frequent charlock here. Hedge-mustard (*Sisymbrium officinale*) and shepherd's purse (*Capsella Bursa-pastoris*) much frequented as food-plants."—E. A. A.

"Yes."—J. A. B.

"No charlock."—J. B.

"No, we cannot find it, but charlock is not abundant in this district."—R. C., for Lord Auckland.

"Charlock affected."—G. D.

"I have noticed charlock, but could never find any caterpillar on it."—J. P. D.

"Having no charlock, cannot say."—J. D.

"A caterpillar is said to have attacked charlock, of which there are great quantities in some fields near here, but I cannot say which variety."—W. F.

"In regard to 'charlock,' I infer by this you refer to what we in this country side (and indeed generally in Scotland) denominate runches, otherwise 'wild mustard,' and in some parts 'skellicks.' The insect feeds as greedily on it as on the turnip."—J. G.

"This is undoubtedly the same caterpillar that frequents charlock. I have carefully examined it with the naked eye, and also with the magnifying glass."—J. H.

"The caterpillar seems to eat the charlock much in the same way as the turnip, neither more nor less."—J. L.

"Charlock not grown here much."—"N. Lincs."

"Charlock and turnips suffered equally, mangel not at all; in some fields have never known them on charlock before, and we have plenty."—R. C. R.

"Scarcely any charlock on farm; couch the chief weed."—J. Sn.

"There certainly is a considerable amount of wild mustard about our land. I did not notice the caterpillar on it, but cannot say I looked carefully."—J. B. S.

"There is charlock (yellow weed, wild mustard) in Islay, but you may drive a summer's day and not see a specimen, so that plant, I may say, has nothing to do with appearance of the grub."—R. S. S.

"No charlock in this neighbourhood."—R. W. S.

"Have no experience of charlock."—G. T.

"In an early-sown field, where turnips (swedes) and charlock came together, both seemed to suffer equally.

"In part of a late-sown field with only a little charlock in it, where, owing to continued dry weather, the charlock came before the turnips (yellow), the former was much more severely attacked than the latter."—D. W.

"Affects charlock about the same as turnips."—F. W.

SUMMARY.—The above observations prove that the diamond-back caterpillars frequent charlock as a regular food-plant, although this plant is by no means always mentioned in lists of the plants especially liable to this infestation.

#### *7. Kinds of birds especially useful in clearing the caterpillars.*

"Cannot say that I observed any birds actually at work devouring the larvæ."—E. A. A.

"Have no doubt but that the starling and the sparrow have assisted largely in mitigating the evil. Possibly the rook may

have also eaten a number of the caterpillars, but of that I am not certain."—A. B.

"I have seen no birds near the field except larks."—F. B.

"I am told that crows and starlings were seen among the caterpillar-eaten turnips. I must say I saw them there no more than usual, and sparrows and smaller birds preferred the barley."—J. A. B.

"Yellowhammer, wagtail, and linnet."—D. C.

"The rook and the plover."—R. C., for Lord Auckland.

"I consider the starling the most useful bird we have in clearing the caterpillars; they have been very active of late, and very numerous. Sparrows are too numerous, and are against the swallows."—G. D.

"The starling is by far the most useful, and the rook to a certain extent."—J. D.

"The common house-sparrow has done a lot of good by picking off the grubs."—J. P. D.

"Crows have been all over the fields since May; many starlings appeared when we had the caterpillars, and I noticed many small birds in the turnips, chiefly linnets."—W. F.

"A great number of sea-gulls have frequented the field, and also grey plovers."—T. F.

"I had noticed the crow paying particular attention to the worst parts of the field, so I shot one of them to see what it had in its crop, and found it full of caterpillars—hundreds of them."—J. H.

"Starlings and thousands of smaller birds might be seen feeding on them."—J. L.

"Starlings in flocks noted feeding."—"N. Lincs."

"There have been thousands of starlings, green and golden plovers, gulls, chaf- and green-finches frequenting all my turnip fields for some weeks, and I have no doubt they have cleared thousands of caterpillars off daily during that time."—W. P.

"Cannot say, but should judge that sparrows, rooks, and wood-pigeons are no use."—F. R.

"Fowls of all sorts followed the hoers and eagerly ate the caterpillars; no birds specially noticed though looked for; last winter killed great numbers of blackbirds and thrushes."—B. C. R.

"Starlings, sparrows, chaffinches, and linnets very plentiful, and all most industrious."—J. Sn.

"Birds did not come much to the turnips, but I believe peewits and starlings are most useful."—J. B. S.

"Cannot speak of any birds being useful, as the caterpillars were too few for the birds to be making a special raid on them."—J. Sr.

"I think the starling. Infested crops have been much frequented by rooks."—R. W. S.

"Starlings and lapwings have done much good in clearing caterpillars; sparrows and rooks are occupied with early oats—no time to spare for caterpillars."—F. W.

SUMMARY.—In 12 of the above 22 observations the starling is mentioned as serviceable. Sparrows are mentioned seven times; once

with the observation that they "preferred the barley"; once that they were "occupied with early oats--no time to spare for caterpillars"; once the name only is mentioned, simply with the observation that "sparrows are too numerous, and are against the swallows," and once that the reporter judged they were "of no use." The three other notes speak more favourably of their services. The observations name many kinds of large and small birds as noticed, and appear to point to assemblage of birds of the neighbourhood where great presence of caterpillars attracted them.

#### CONCLUSION.

The full teaching given in the foregoing reports can only be gained by careful working out of all the points of information, both as to coincidence and also in comparison one with another.

In the summaries I have endeavoured to give some of the main points, but just looking at the matter generally, it appears to me (put very shortly) to stand as follows:—

I think the evidence clearly points to the infestation having been wind-borne to this country, because we have certain record of the appearance of great flocks of moths at various places on the eastern coast shortly before the caterpillars made their appearance, and where specimens of these moth appearances were submitted to entomologists they were found to be diamond-backs. Also, the observations show that there was no special amount of charlock (one of the chief field-weed plants on which the diamond-back caterpillars live), nor had weather been such as to prevent, either in previous autumn or before sowing the turnips, a careful cleaning, which would have got rid of food-plants of the pest. Further, it may be presumed that, if there had been the great number of caterpillars at work in the strip of country from Dover to Aberdeen which would have been requisite to produce our recent attack, something would have been noticed of them then, just in the same way as the presence and ravage have been noticed now.

The little green caterpillars might easily have been overlooked, but every farmer would have been quick to observe what had happened to the leafage of the turnips.

Also we have, I think, evidence that the attack came with a burst and gradually spread inland. This advance was found by Mr. Robson, at Hartlepool, to be at the rate of  $1\frac{1}{2}$  miles in two days. In that time from the appearance of the moths at Hartlepool, he found they had reached a locality where they were totally absent two days before.

This appearance of the pests coincided in some cases certainly with dry weather, good for the infestation, and bad for the plants it attacked; and that this weather was general may be presumed from the many reports, which after a while followed the first notice of ravage, that now rain had come attack and its consequences were lessening.

Up to the past summer we have only had (so far as I am aware)

a single previous instance of really widespread and severe attack recorded of diamond-back moth ; and as we know that the insect is one recorded to be "always present, and sometimes very abundant, amongst cabbages and cruciferous plants," there seems to me to be good reason to hope that the attack is only one occurring seriously under special coincident circumstances, as of great importation and favourable weather. If not, it is inexplicable why the attack (as is customary with most of our common crop insects) should not have been generally distributed.

The relative amount of attack to plants on different kinds of soil, with different kinds of manurial preparations of ground, dates of sowing, &c., should be carefully studied if results are needed. The minute differences require too much space to enter on here, and indeed in some cases the reports sent me were so carefully detailed that I have with much regret not been able to insert the whole.

The most important part of all, namely, possibility of some reasonable amount of remedial treatment, certainly does not lie beyond hope. In this I have especially directed my attention to use of applications and implements which are always at hand or may be easily purchasable.

We all know that when plants are perishing from loss of leafage, one great assistance to us is an application which will immediately push on growth—and in the record of experiments nitrate of soda is frequently mentioned as having answered well. For removal of the caterpillar pests the use of scufflers or horse-hoes, with light boughs before them, is frequently mentioned as doing much good.

Such remedies as these lie within the means of all agriculturists ; and though, as with most other crop remedies, sometimes they answer and sometimes they do not, yet (for one thing) it may be expected that, in case the attack recurs, we should be ready, and apply the remedies in such good time that they *would* succeed, and (for another) that though very likely remains of this summer's guests may supply some amount of trouble for next year, yet so far as I can form an opinion, it appears to me that unless under very special coincidences, we have no cause to fear another such agricultural visitation upon our coasts.

ELEANOR A. ORMEROD.

---

## QUARTERLY REPORT OF THE CHEMICAL COMMITTEE

JULY, 1891.

1. Mr. P. Dalton, of Cummersdale Mills, Carlisle, sent for analysis on May 6, 1891, a sample of Flesh, Blood and Bone Manure, the price of this being 5*l.* 5*s.* per ton for cash, delivered;  $2\frac{1}{2}$  tons had been purchased from the manufacturer, Mr. Dennis Hughes, of Grinsdale Bridge Manure Works, near Carlisle. The manure was ordered for top-dressing purposes. The following analysis and report were given:—

May 15.			
Moisture . . . . .	21.75	}	100.00
<sup>1</sup> Organic matter and water of combination . . . . .	22.43		
Monobasic phosphate of lime . . . . .	7.75		
equal to tribasic phosphate of lime (bone phosphate) rendered soluble by acid . . . . .	(12.25)		
Insoluble phosphates . . . . .	5.54		
Sulphate of lime, alkaline salts, &c. . . . .	33.75		
Insoluble siliceous matter . . . . .	8.78		
<sup>1</sup> Containing nitrogen . . . . .	.92		
equal to ammonia . . . . .	1.12		

Just about twice the price it should be.

An allowance of 5*l.* on the transaction was made by the vendor, who explained that one of the ingredients in the mixing was not what it should have been.

2. Mr. A. de Mornay, of Col d'Arbres, Wallingford, sent on June 9, 1891, a sample of what he had purchased as Dissolved Bones, the price being 5*l.* 10*s.* per ton, delivered, less 5*s.* per ton discount in four months. Two tons of the manure had been bought from the manufacturers, Messrs. Weedon Bros., The Chemical Manure Works and Bone Mills, Goring, near Reading. The following report was given on the sample:—

June 15.			
Moisture . . . . .	13.98	}	100.00
<sup>1</sup> Organic matter and water of combination . . . . .	15.31		
Monobasic phosphate of lime . . . . .	11.29		
equal to tribasic phosphate of lime (bone phosphate) rendered soluble by acid . . . . .	(17.69)		
Insoluble phosphates . . . . .	7.53		
Sulphate of lime, alkaline salts, &c. . . . .	48.57		
Insoluble siliceous matter . . . . .	3.32		
<sup>1</sup> Containing nitrogen . . . . .	.64		
equal to ammonia . . . . .	.77		

This should not be called dissolved bones; it is a mixture containing comparatively little bone, and is a very inferior manure to dissolved bones.

3. Mr. F. E. Cotton, agent to Mr. F. Monckton, of Brewood, Stafford, sent on June 22, 1891, a sample of Artificial Manure, of which three tons had been purchased of Mr. R. Patrick, Bone and Chemical Manure Works, Oldbury, near Birmingham, the price being 6*l.* 10*s.* per ton, carriage paid. The following analysis and report were given :—

		July 2.	
	Moisture . . . . .	10.95	
<sup>1</sup>	Organic matter and water of combination . . . . .	31.08	}
	Monobasic phosphate of lime . . . . .	5.93	
	equal to tribasic phosphate of lime (bone phosphate) rendered soluble by acid . . . . .	(9.28)	
	Insoluble phosphates . . . . .	5.73	
	Sulphate of lime, alkaline salts, &c. . . . .	42.23	
	Insoluble siliceous matter . . . . .	4.08	
	<sup>1</sup> Containing nitrogen . . . . .	1.99	
	equal to ammonia . . . . .	2.41	

The price asked is enormous; you ought, for cash, to get as good a manure for half the price or but little more.

On complaint being made the vendor said a mistake had been made in the truck of manure forwarded, and he charged the delivery at the rate of 3*l.* per ton only, exclusive of carriage, making in all an allowance of 9*l.* 4*s.* on the three tons delivered.

4. Mr. R. Richardson, of Arnold Grange, Skirlaugh, Hull, sent for analysis, on June 6, 1891, a sample of Bone Meal, of which 1½ tons had been purchased, at a cost of 6*l.* 3*s.* 4*d.* per ton, at the Works. One ton had already been used, and the sample only represented the 10 cwt. which were left

The following analysis and report were returned :—

		June 13.	
	Moisture . . . . .	10.95	
<sup>1</sup>	Organic matter . . . . .	27.70	}
	Phosphate of lime . . . . .	41.77	
	Carbonate of lime, &c. . . . .	11.33	
	Sand . . . . .	8.25	
	<sup>1</sup> Containing nitrogen . . . . .	3.25	
	equal to ammonia . . . . .	3.94	

This sample is not pure, being mixed with carbonate of lime and having excessive sand. It is of low quality, deficient both in phosphates and in nitrogen.



Mr. Richardson declined to give the vendor's name, but said that, though no guarantee had been given him, he had received an allowance of 4*l.* on the last half-ton.

5. Mr. G. W. Finn, of Westwood Court, Faversham, sent on June 4, 1891, a sample of American Linseed Cake for analysis, he having purchased about thirty tons of this cake from Messrs. Wakeley, Rainham, Kent. It was known as "Dean's" Cake, the price being 8*l.* 10*s.* per ton. The report given on this sample was as follows :—

June 9.

Moisture . . . . .	10 25	} 100·00
Oil . . . . .	9 10	
<sup>1</sup> Albuminous compounds (flesh-forming matters) . . . . .	27 75	
Mucilage, sugar, and digestible fibre . . . . .	31 54	
Woody fibre (cellulose) . . . . .	10 76	
<sup>2</sup> Mineral matter (ash) . . . . .	10 60	
<sup>1</sup> Containing nitrogen . . . . .	4 44	
<sup>2</sup> Including sand . . . . .	5 05	

This is an impure cake containing over 5 per cent. of sand.

No allowance was made by the vendors. They sent Mr. Finn the copy of an analysis of what they said was the same cake as supplied to him. This was as follows :—

COPY OF ANALYSIS OF "DEAN'S" CAKE.

Water (lost at 212° F.) . . . . .	9 20	} 100·00
Oil . . . . .	10 60	
<sup>1</sup> Albuminous (flesh-forming compounds) . . . . .	29 11	
Mucilage, digestible fibre, &c. . . . .	34 30	
Indigestible (woody) fibre . . . . .	10 33	
<sup>2</sup> Mineral matter (ash) . . . . .	6 46	
<sup>1</sup> Containing nitrogen . . . . .	4 60	
<sup>2</sup> Containing sand . . . . .	1 10	

This is a pure linseed cake, made from very clean seed.

(Signed) R. A. WARREN,  
Chairman.

July 28, 1891.

## Notes, Communications, and Reviews.

### THE RELATIONS OF THE DISEASES OF ANIMALS TO THOSE OF MAN.

THIS year's session of the International Congress of Hygiene and Demography will be memorable in the agricultural world from the fact that, for the first time in the history of the meetings of the Congress, there has been a section entirely devoted to what may fairly be termed the interests of the community generally and of agriculturists specially.

The President, Col. Sir Nigel Kingscote, K.C.B., in his opening address struck the key-note: "The subjects," he said, "that we shall have to discuss are of the greatest and most immediate importance to all classes of the community in every country, and I think myself happy in having been honoured with the presidency of the first assemblage of medical men, veterinarians, and agriculturists who have ever met on common ground to discuss questions of the profoundest interest to them and to the world at large."

From the record of work done at these meetings there can be little doubt that the objects kept in view by those responsible for the formation of this section (amongst whom certain Members of Council of the Royal Agricultural Society of England took a prominent part) have been fully attained, for there has been a freer interchange of ideas and opinions amongst the different sections of practical and scientific men above mentioned than has previously taken place. The subject has been approached from the point of view of those engaged in practical agriculture, from that of the skilled veterinarian (both British and foreign), and lastly from the side of the scientific hygienist and medical officer of health; and it is interesting to note, from the whole tenor of the discussions, that all could agree that interests which are sometimes held to be conflicting have really much in common, and that what is best for the community at large is also undoubtedly best for the interest of cattle-breeders and of agriculturists generally. It may be well, therefore, to give a short *résumé* of the more important facts that were brought out in the various discussions—discussions which were carried on with such vigour and animation, but withal with such courtesy and good temper, that

all who took part in them were not only instructed or gave instruction, but were also equally gratified.

The intimate association between the recent advances in bacteriological science and practice and their relations to diseases of animals and to general hygiene was fitly introduced in the discussion on "The Prevention of Hydrophobia," to which Dr. Roux, of Paris, and Dr. George Fleming contributed most interesting papers. Dr. Roux's contribution, almost entirely statistical, was prefaced by a valuable account of the Pasteur method, but the main interest centred in the figures he was able to give. From 1886 to 1890, he said, in all, there had been 9,465 patients treated in Paris; of these 90 had died, but the largest proportion of deaths was amongst foreign patients—a fact that was ascribed to the late period at which treatment was commenced after the patients had been bitten; this was especially well marked amongst English patients, of whom 389 had been treated. The mortality amongst patients bitten about the head, if left untreated, was about 80 per cent., whilst of 710 persons bitten about the head who had been treated at the Pasteur Institute only 24 had died, or 3.38 per cent. This was the most interesting fact brought out in the whole paper, and one which should be more convincing than any other statement or argument could possibly be. As the treatment had become perfected the rate of mortality had declined; thus, in 1886 it was 1.34 per cent., whilst in 1889 and 1890 it had fallen to 0.54 and 0.71 per cent. respectively.

Dr. Fleming, in his paper on "The Prevention of Rabies," drew attention to the fact that really the most efficient method of dealing with this disease was by the destruction of rabid dogs; the stringent detention of wandering and ownerless dogs, which if not claimed within a certain period should be destroyed; efficient muzzling, and the imposition of a dog-tax and registration, not in localised areas only but throughout the country. Of course, it might be pointed out that no muzzle will prevent a mad dog from biting when it gets to the rabid stage, but an animal is as a rule not so dangerous during this stage as in the morose preliminary period, during which the disease should always be diagnosed and the animal put out of its misery.

It has sometimes been suggested that all dogs should be inoculated with anti-rabic virus; but it could be gathered from Dr. Roux's address that the inoculation is not so much protective as antidotal, and he pointed out that in those cases where the virus might remain latent in the system for months or even years, the effect of the preventive inoculation might disappear before the activity of the virus manifested itself, and that in this way some of the fatal cases which have occurred at a late date might be accounted for. Whatever measures are taken (and the simplest, such as leashing and muzzling of dogs, careful registration, and the destruction of ownerless dogs, are the best), they should be carried out stringently throughout the kingdom, and not in districts only. If these were strictly enforced we might soon be freed from this scourge. The Pasteur treatment in the meantime must be looked upon as neces-

sary, in order that the mortality amongst patients and dogs that have the ill-fortune to get bitten may be diminished. As a prophylactic treatment the outcome of Galtier's labours can scarcely yet be looked upon as completely successful.

At the same sitting Professor Brown gave an exceedingly interesting demonstration on "Animal Parasites," and Professor Railliet, of Alfort, gave an account of the "Parasites transmissible from Animals to Man," which, when published, should prove of extreme value to those who study medical or veterinary hygiene.

Professor Brown, before his demonstration, referred to Symbiosis, Mutualism, Commensualism, and Parasitism, defining the different shades of meaning involved in each term. The demonstration included specimens of specially prepared and mounted parasitic organisms, and photographs, all of which were projected by means of a lime-light lantern on to a screen at the back of the hall. There were included beautiful examples of trematode worms; the ordinary liver-fluke, both in the embryo state and in its adult form; cestode worms; various forms of tapeworms, with their developmental cystic stages, including the forms met with in the human subject, in dogs, sheep, &c.; nematode worms, or round or thread worms, especially those forms found in the digestive canal and in muscles; the whip-worm, the worm of trichinous pork, &c.; and the *Acanthocephalæ*, or thorn-headed worms.

Professor Railliet, after dividing the parasites transmissible from animals to man into animal and vegetable, and external and internal, and the external parasites into temporary and stationary, said that the internal parasites were nearly all stationary. Some common to man and animals, or living more especially in animals, may develop accidentally in man (*Trichina spiralis* of measy pork). Others are compelled to penetrate into the organism of man in order to complete their life-history, so that they are usually transmitted direct (*Tænia solium*, the common tapeworm). Indirect transmission may take place through the medium of food or water which animals have polluted or infected by depositing ova or embryos. Here two kinds were found—those in which the parasites, living in the adult state in animals, are capable of attaining the same state in man, as with the common liver-fluke; and those which, living in an adult state in animals (*Tænia echinococcus* in the dog), only develop in the larval stage in the human subject (hydatid cysts).

Direct transmission is brought about by the consumption of the flesh of infected animals, in which case the parasites living in the larval state in animals become developed into their adult form in man, as in the case of the tapeworms of measy pork and beef, and in the *Trichina spiralis* of trichinous pork.

As to the means to be taken to prevent the spread of these parasites, we ought in the first instance to avoid contact with animals suffering from parasitic affections which we know to be transmissible to ourselves, at the same time endeavouring to destroy the parasites and their progeny, not only in the animals themselves, but also in all parts which may have been affected. In the second

case, we must only consume suspected food and water after careful examination, and after boiling, filtration, or other means of purification, where necessary. Lastly, effective general sanitary measures should be taken to complete the cordon of protection.

In the discussion on "Food Poisoning," it appeared to be the general opinion that thorough cooking of all meat and the most scrupulous cleanliness and ventilation of places where cooked meat was stored, sold, or otherwise prepared, with the adoption of every possible protection against the introduction into them of ground-air, or of morbid or unwholesome emanations, were the essential points to be considered as regards prevention of tainting and meat infection. The noxious properties of poisonous meat might be due to disease of the animals or to food obtained from them; inoculation of the foods with specific pathogenic microbes might take place outside the body of the animal from which the food was derived; or, again, the infection with saprophytic toxicogenic bacteria of food-stuffs, such as meat and milk, might occur. We still have much to learn about the sterilisation of milk and the destruction of certain organisms which, introduced into this medium, appear to set up poisonous fermentation, not only outside the body, but even after it has been introduced into the stomach, for it is found that heating and partial sterilisation of milk are not always sufficient to destroy very resistant organisms, which, even after introduction with the milk into the stomach and intestines of children, may reinfect the milk and give rise to those forms of diarrhœa so frequently met with.

Dr. Klein's paper on "Infectious Udder Diseases of the Cow in Relation to Epidemic Diseases of the Human Subject" started a very lively and interesting discussion, for although none of the speakers whose opinions were supported by the authority of actual experiment were able to confirm Dr. Klein's results, yet these results are so positively stated, and Dr. Klein has been able to produce such definite diseases, that the matter cannot at present be looked upon as finally settled, and there is no doubt that, on the first outbreak of diphtheria or scarlet fever which appears to be associated in any way with an epidemic of vesicular eruption on the udders of cattle, the whole question will be again opened up. It would be well, therefore, as Professor Brown pointed out, that any such investigation should be carried on by a committee comprised of representatives of the Local Government Board and of the Board of Agriculture, with the assistance of some independent authorities. Only in this way can the matter be settled, as at present each section is convinced that the other is absolutely at fault, and certainly we should say, with Sir Roger de Coverley, "There is much to be said for both sides."

Professor Ostertag, of Stuttgart, contributed one of the most interesting papers of the meeting, on "Milk Diseases and the Regulation of Milk Supply." As his remarks were extremely practical, we may here summarise his conclusions. For sanitary reasons he considers that the following kinds of milk should never be allowed to be placed on the market: viz. (1) Milk which without being necessarily prejudicial to health is still peculiar

in colour, taste, or consistence, especially when the taste is in any way nauseous; (2) any milk that is prejudicial to health, or which on good grounds is suspected of being so. In the first group he would class colostral, blue, red, and yellow milk, and slimy or thready milk (all of which owe their peculiar properties to the growth of micro-organisms), bitter, salt, or abnormal-smelling milk, and milk that has been rendered impure by accidental contamination with dirt of various kinds. In the second group would come the milk of animals that have been fed on poisonous fodder, or to which have been administered certain medicaments. Under this classification would come also the milk from animals suffering from tuberculosis, malignant pustule, cowpox, aphthæ, suppuration, ulceration, &c.; the milk from animals affected with feverish ailments or with different forms of inflammation of the udder; milk which might be infected by immediate contact with patients suffering from typhus, cholera, &c., or through being kept in rooms where such persons were lodged; and, finally, milk might become injurious and unfit for sale through being carried in unsuitable metal vessels, from which injurious substances might find their way into the milk. In order to guard against these dangers, he considers that it is advisable: (1) That all dairy farms should be licensed; (2) that all animals kept for milking should be examined by a veterinary surgeon at frequent stated intervals; (3) that the owners of dairy farms should be bound to supply good, undamaged fodder to the cattle, and to give immediate notice of the illness of any milch cow to the attendant veterinary surgeon, without whose leave the milk from a diseased animal should never be allowed to be sent to market; (4) that the milking should be performed with punctilious cleanliness, and that no person suffering from an infectious disease should be employed for milking cattle; (5) the milk, mixed, should be cooled and stored in special rooms, not in living or sleeping rooms; (6) milk should be transported only in suitable vessels; (7) during the prevalence of aphthæ, only milk that has been boiled should be brought into market; whilst all milk mentioned above, under headings (1) and (2), should be rigidly excluded, and on the outbreak of any epidemic in a house where dairy farming is carried on the sale of milk should be forbidden; (8) the greatest care should always be exercised in obtaining the so-called "infants' milk." The regulations as to the feeding of cows, attention to cleanliness in milking, and the cooling and proper transport of the milk, should be strictly observed.

In the discussion that followed, the prevailing opinion seemed to be that the introduction of general regulations was required, but that the power should not be placed in the hands of local authorities, who rarely took advantage even of the powers that they had, under the Contagious Diseases (Animals) Act, to enforce regulations with regard to the milk supply. These necessary regulations really resolved themselves into (1) the registration of all dairy farms, cowsheds, and milk-shops; (2) efficient inspection of all such registered premises. Professor Brown hit the nail on the head when he gave it as his

opinion "that, for carrying out any efficient system of milk inspection, and of inhibiting the sale of milk considered to be dangerous, a system of compensation would have to be devised, so as to prevent dairymen whose milk supply was stopped from suffering severe loss."

As regards the inspection of meat and its relation to the prevention of disease, the same difficulties are met with as in the case of milk, and the same regulations and compensations must necessarily, in the long run, be applied. In this matter we have much to learn from Continental authorities, whose rules (modelled greatly on the experience gained from the beneficent working of the Hebrew religious legislation, as regards meat and milk, on the health and physique of the Jews) have even now been attended with most satisfactory results.

Passing from the general to the special, the discussion on "Tuberculosis" before the combined Sections II. and III., under the presidency of Sir Joseph Lister, came in very opportunely. That there is grave danger arising from the use of tuberculous milk must be accepted as proved without any shadow of doubt. As regards infection of the digestive tract through ingestion of meat from tuberculous animals there was more variety of opinion; but from the general tone of the discussion it was gathered that there undoubtedly exists a danger—a danger, however, which has been considerably exaggerated, but one which requires that precautions should be taken in order that stock-feeders, dairy farmers, and others should know exactly what is expected of them, and in order, too, that public confidence may be restored. Here, again, registration, inspection, wise and well regulated confiscation, with some scheme of compensation (either by assisted mutual insurance, which would be the preferable form, as we might then rely that the slightly increased cost would eventually fall upon the consumer, or out of local rates or Imperial taxes), are required—a system of confiscation and compensation which would prove equitable to breeders and cattle-dealers alike, and would consequently secure their co-operation and support in rendering effective any regulations that might be framed.

From the discussion on "Actinomycosis" it may be gathered that this disease is not to be placed in the same category as tuberculosis. It is seldom transmissible directly from animals to man or from man to animals, and in many cases the appearance of actinomycotic wens, of wooden tongue, and the like, appears to have little influence in deteriorating the quality of the food derived from the infected animals, except in the general way that all suppuration brings about such deterioration. It was pointed out that the disease might have a common origin for both animals and man, that it was generally transmitted by means of fodder—especially by means of straw—though it was generally agreed that we have still much to learn about the history and development of the organism which appears to give rise to the disease; Mr. Goodall suggesting that a careful investigation of the diseases communicable from the vegetable to the animal world would be productive of very fruitful results.

M. Chauveau's and Professor Duguid's papers on "Anthrax" were

especially interesting. They were the outcome of the work of two scientific men who were amongst the earliest workers at the first disease in which a micro-organism was constantly found as the causal agent of a specific malady. From the discovery of the bacillus of anthrax a new era in the study of contagious and transmissible diseases may be said to date.

The work in this section throughout the Congress was intensely practical, and much of it affords promise of better times to come for stock-owners, dairy farmers, and others. Indeed, one cannot but be impressed by the fact that work which, carried out in connection with the health of the human community, has lowered the death-rate so enormously during the last few decades, should, when applied to the breeding, rearing, and storing of cattle, be equally successful; and that the diminished death-rate or disease-rate must necessarily be followed by a corresponding increase in the value and food-producing power of cattle.

G. SIMS WOODHEAD.

---

## THE AGRICULTURAL HOLDINGS ACT.

*Note upon a case relating to the power given to a landlord by this Act to obtain a charge upon a farm for the amount paid to the tenant for compensation.*<sup>1</sup>

THE Agricultural Holdings Act provides, by section 29, that "a landlord on paying to the tenant the amount due to him in respect of compensation under the Act, shall be entitled to obtain from the County Court a charge on the holding, or any part thereof, to the amount of the sum so paid," and that "the Court shall, on proof of the payment, and on being satisfied of the observance in good faith by the parties of the conditions imposed by the Act, make an order charging the holding, or any part thereof, with repayment of the amount paid, with such interest, and by such instalments, and with such directions for giving effect to the charge as the Court thinks fit." The question at issue in the case now under consideration was whether, under this section, the executors of a landlord who was tenant for life of the farm, and who had died after the amount payable to an outgoing tenant for compensation had been fixed, could obtain a charge on the farm for that amount, they having paid it to the outgoing tenant. After considerable difference of opinion amongst the judges before whom the case was successively tried, the Court of Appeal decided that the executors could obtain

---

<sup>1</sup> *Gough v. Gough*, reported in the *Times* of April 15 and June 29, 1891, and in the *Weekly Reporter*, vol. xxxix. pp. 494 and 593.



such a charge. The difficulty in the case was caused by the wording, not only of the section which I have just quoted, which it will be noticed speaks merely of "a landlord," but also of the section (61) which contains definitions of numerous words and expressions used in the Act, amongst others of the word "landlord." Such definition runs thus:—"Landlord in relation to a holding, means any person for the time being entitled to receive the rents and profits of any holding," and at the end of the section there is this clause: "The designations of landlord and tenant shall continue to apply to the parties until the conclusion of any proceedings taken under, or in pursuance of this Act, in respect of compensation for improvements, or under any agreement made in pursuance of this Act."

The facts of the case were as follows:—

Mr. Gough, as tenant for life of a farm, let the same to a tenant from year to year. In March, 1889, the tenant gave notice of his intention to quit the farm at Lady Day, 1890, and in January, 1890, served upon Mr. Gough notice of a claim for 130% for unexhausted improvements under the provisions of the Agricultural Holdings Act. On April 5 the amount payable by Mr. Gough to the tenant was fixed by valuers appointed under the provisions of the Act at 35%. On April 8 Mr. Gough died, having up to that date been in receipt of the rent of the farm as tenant for life, and on April 24 his executors paid the 35% to the tenant. They then presented a petition in the Wells County Court asking for a charge upon the farm in respect of the 35% under section 29 of the Act. The remainderman, or person who had at Mr. Gough's death come into possession of the farm, opposed the petition, and the County Court judge held that the executors were not the "landlord" within the definition given in section 61 of the Act, and were therefore not entitled to the charge.

From this decision the executors appealed to the Queen's Bench Division of the High Court, and the appeal was heard by Mr. Justice Cave and Mr. Justice Vaughan Williams in January last. Those two learned judges, after taking time to consider the case, differed in opinion, the former holding that the County Court judge was right and that the executors could not obtain the charge, while the latter held that the County Court judge was wrong, and that the executors could obtain the charge. Under these circumstances the decision of the County Court judge held good, but the executors had leave given them to carry the case to the Court of Appeal if they wished to do so. This they did, and on June 26 last the case came before the Court of Appeal, which consisted of the Master of the Rolls (Lord Esher) and Lords Justices Bowen and Kay. All these three learned judges were of opinion that the County Court judge and Mr. Justice Cave were wrong, and that Mr. Justice Vaughan Williams was right in the conclusion at which he had arrived: viz., that Mr. Gough's executors had the right to obtain the charge they sought. The judgments of the Master of the Rolls and of Lord Justice Bowen proceeded mainly upon technical

grounds, which would hardly be interesting to readers of the Journal; but that of Lord Justice Kay contains some weighty observations on the general scope of the Act of 1883, as well as the technical grounds applicable to the case immediately before the Court, and is therefore given, at some length. His Lordship said:—

“The Agricultural Holdings Acts give to the tenant rights which he did not possess before to claim compensation from his landlord for unexhausted improvements. Under the Act of 1875 it was possible for the landlord and the tenant to contract themselves out of the Act. But the Act of 1883 went a step further and forbade that, and made the provisions of the Act binding on the landlord. It is clear that in the present case the executors were bound to pay the 35*l.*, and they did pay it. Turning to section 29, I find that these executors, if they can be brought within the term landlord, are entitled to obtain a charge upon the land for this 35*l.* It was paid by them for unexhausted improvements of which the land would get the benefit—that is, the land of the remainderman—and out of which the estate of the tenant for life would get no benefit whatever. Can it have been intended that under this Act the landlord, if he is alive, can obtain a charge on the land, but if he has died, his executors cannot obtain it?—that they should pay out of his estate for improvements upon the land of the remainderman, and yet get no charge upon the land which has been improved? I said during the argument that it would be monstrous if the Act allowed such an injustice as that to take place, and I think that the language which I used is not too strong to describe such a result. It is incredible that the Legislature should have intended that the Act should have that effect. But is that the necessary construction?

“Turning to the definition of the word landlord, I think that it is probable that the executors do not come within it, and I do not rely upon that. It is argued that in the Agricultural Holdings Act, 1875, s. 4, ‘landlord’ is defined so as to include the executors, and that that is not so in the present Act, whereas in the definition of ‘tenant’ the words including the executors are still retained. That argument is worthy of attention, but there is another difference between these sections of the two Acts.” [His Lordship read the clause in section 61 of the Act of 1883 which I have cited above, and the corresponding clause in the definition section of the 1875 Act, and continued]:—“These clauses are like and yet very unlike; is not the reason for the alteration the fact that the executors of a landlord have been omitted from the definition of ‘landlord?’ so that although not within the definition, they may be within the designation as long as proceedings under this Act are going on. It seems to me that it was a mistake to say that a landlord should mean his executors, for the landlord’s interest often ceases entirely at his death, and such a definition might therefore give rise to difficulties. But to say that the executors shall be included in the designation of landlord until the conclusion of proceedings under this Act makes the Act intelligible; for the proceed-

“ings are not determined by the death of a landlord who is tenant for life of the property, nor until this application for a charge has been made and disposed of. The result is that, this being a proceeding under the Act, the executors, as parties to that proceeding, are within the designation of ‘landlord’ until the conclusion of the proceedings, and are entitled to this charge.”

S. B. L. DRUCE.

---

## THE CANKER OF THE LARCH.

THE conclusion arrived at by Mr. Carruthers in the last number of the *Journal* (page 299) will, I think, be received with consternation by landowners and others interested in planting operations. When we are told that “it may deserve consideration whether it would not be better to replace the larch by other trees suitable to our climate and fitted for the purposes for which the larch has been so long employed,” it is pertinent to ask if any known tree will answer this description.

For general utility it must be admitted the larch has no equal. Even the early thinnings possess a value which, though small, is far greater than that of the young poles of any other description of tree; and, coming to maturity at a very early age, the timber is scarcely surpassed, even by that of the oak, for toughness and durability. These qualities are of special advantage to landed proprietors, and without doubt more larch is used for fencing, gates, and other estate purposes than any other timber. It is, moreover, the best material for railway-sleepers, for cladding railway waggons, for boat building, and for telegraph and scaffold poles, being far tougher and more enduring than Baltic redwood.

Under these circumstances it behoves us to consider whether the larch cannot be cultivated here in such a way that the losses arising from this scourge may be minimised.

Mr. Carruthers gives excellent advice as to the means of detecting the canker in the young plant, and the importance of rejecting and destroying every specimen that is already attacked; and I think if this is done thoroughly, and the plantation is properly attended to in its early years, we may keep the disease at bay.

It is a matter of common observation that the plantations in which canker is most prevalent are those in which the soil is wet and undrained, in which grass and undergrowth have not been kept down in the early life of the plant, and which have not been thinned sufficiently soon. These conditions favour the damp atmosphere that, as Mr. Carruthers points out, is necessary for the germination of the spores. Plantations consisting of larch and pine, or of larch alone, are also more subject to attack than those of larch and hardwoods, for the same reason, while it is unusual to find diseased specimens in larch trees scattered about in beech or oak woods.

I therefore venture to suggest that planters should keep the following points in view :—

1. Do not plant larch in wet, undrained soil.
2. Select plants free from disease.
3. Do not plant too closely. Four feet apart is quite near enough in most cases and, in sheltered situations, five feet is preferable.
4. Plant hardwoods with the larch.
5. Keep down the herbage. If hoeing is considered too expensive, this can be effected by mowing with a short scythe.
6. Thin in good time.

The last point is somewhat indefinite, but it may be elaborated by saying that as soon as the branches of one tree press upon those of another, so as to interfere with the healthy development of sufficient foliage, thinning should be resorted to. A too early thinning is a mistake from which a plantation will generally recover, but if thinned too late the result is often fatal.

ROBERT ANDERSON.

## AMERICAN FARM CROPS.

THE United States Department of Agriculture has recently issued an "Album of Agricultural Graphics," which is in some sense a companion to the "Album of Agricultural Statistics," referred to in the Journal last year (Vol. I., 3rd Series, p. 657,—a map of the United States being given on page 659). The present elaborately-prepared publication comprises a series of ten outline maps of the United States, each of which illustrates, by means of different shades of colour and peculiarities of mechanical drawing, the average yield and value per acre of one of the chief farm crops in every State or territory. The figures both of yield and value are based on official returns, and with regard to both the average of ten years is taken.

The mean results for the United States come out as follows :—<sup>1</sup>

Crop	Yield per acre	Value per acre	Crop	Yield per acre	Value per acre
	bushels	£ s. d.		bushels	£ s. d.
Corn ( <i>i.e.</i> maize) . . . . .	24·1	1 19 5	Potatoes . . . . .	76·2	7 19 9
Wheat . . . . .	12·0	2 1 9		lb.	
Oats . . . . .	26·6	1 14 0	Tobacco . . . . .	727·1	12 16 3
Rye . . . . .	11·9	1 14 5	Cotton . . . . .	168·1	3 5 4
Barley . . . . .	21·7	2 13 2		tons	
Buckwheat . . . . .	12·8	1 14 4	Hay . . . . .	1·19	2 6 2

With reference to the yield per acre, it is observed in the short report which prefaces, and to some extent summarises, the graphic

<sup>1</sup> The values, which are of course given in dollars, have been here throughout reduced to English currency.—R. H. R.

representations, that the past decade has been marked by several years of drought, "which have reduced the rate of yield below the average of the preceding decade, a period comparatively exempt from dry seasons." The years of sufficient rainfall show no diminution in the rate of yield.

The range of crop-production is very considerable. The yield per acre of maize varies from 9·4 bushels in South Carolina to 32·8 bushels in Nebraska. The statistician remarks in reference to this crop that it is worth inquiring why the average yield per acre for ten years is 32·7 bushels in New Hampshire, which possesses a granitic soil, which is so far removed in fertility from the ideal maize-bearing alluvium, and only 27·7 bushels in Illinois, which is endowed with extraordinary fertility. Again, with regard to wheat, the yield per acre is as low as 5·7 bushels in South Carolina and Mississippi, and rises to 19·5 bushels in Colorado. In Great Britain, it may be observed, the estimated ordinary average yield of wheat is 28·80 bushels per acre, and the range is from 14·22 in Anglesey, to 36·71 in the county of Edinburgh.

From the point of view of the British farmer, the most interesting crop in the United States is that of wheat, because it is practically the only one which comes into direct competition with his own produce. In view of the quantities of wheat and wheat-flour—averaging some two million tons per annum—which the American farmers have been sending to this country during the past decade, it is of interest to observe what they have themselves been obtain-

	Average yield per acre	Average value per acre		Average yield per acre	Average value per acre
	bushels	£ s. d.		bushels	£ s. d.
Maine . . . . .	13·6	3 12 7	Indiana . . . . .	13·1	2 7 4
New Hampshire . . . . .	14·4	3 16 0	Illinois . . . . .	13·4	2 7 2
Vermont . . . . .	16·9	4 2 3	Wisconsin . . . . .	12·0	2 1 9
Massachusetts . . . . .	16·3	4 6 5	Minnesota . . . . .	12·5	1 18 9
Connecticut . . . . .	16·6	3 19 9	Iowa . . . . .	10·6	1 11 6
New York . . . . .	14·7	3 2 7	Missouri . . . . .	11·7	1 18 5
New Jersey . . . . .	12·9	2 16 7	Kansas . . . . .	13·9	1 19 2
Pennsylvania . . . . .	12·6	2 12 9	Nebraska . . . . .	11·1	1 8 7
Delaware . . . . .	11·6	2 8 9	California . . . . .	12·5	2 3 1
Maryland . . . . .	12·2	2 10 3	Oregon . . . . .	16·3	2 10 1
Virginia . . . . .	8·2	1 13 5	Nevada . . . . .	17·6	3 6 6
N. Carolina . . . . .	6·0	1 6 7	Colorado . . . . .	19·5	3 7 7
S. Carolina . . . . .	5·7	1 8 0	Arizona . . . . .	13·8	2 13 0
Georgia . . . . .	6·0	1 9 2	Dakota . . . . .	11·9	1 11 4
Alabama . . . . .	6·0	1 7 5	Idaho . . . . .	17·1	2 19 0
Mississippi . . . . .	5·7	1 6 4	Montana . . . . .	17·6	3 0 4
Texas . . . . .	10·0	1 19 3	New Mexico . . . . .	13·6	2 13 10
Arkansas . . . . .	7·5	1 10 1	Utah . . . . .	17·2	2 12 11
Tennessee . . . . .	6·7	1 4 9	Washington . . . . .	17·0	2 10 8
West Virginia . . . . .	10·2	2 0 1	Wyoming . . . . .	18·0	3 1 11
Kentucky . . . . .	9·4	1 14 3			
Ohio . . . . .	13·6	2 11 9			
Michigan . . . . .	15·2	2 15 10	Average . . . . .	12·0	2 1 9

ing per acre for the produce which has tended so much to depress the British corn markets in that period. The table on page 645 shows the average yield and return per acre for wheat, based on the results of the past ten years, in each State and territory of the American Union, except Louisiana, where no wheat is grown.

For the purpose of comparison I have worked out from the official figures the average value per acre of the wheat-crop in Great Britain in each of the past seven years, from which it appears that the gross return in this country is nearly three times as much as in the United States:—

Year	Yield per acre	Price per quarter		Average value per acre		
		s.	d.	£	s.	d.
	bushels					
1884	29·96	35	9	6	13	5
1885	31·31	32	10	6	9	1
1886	26·89	31	1	5	4	1
1887	32·07	32	6	6	10	2
1888	28·05	31	11	5	11	6
1889	29·89	29	10	5	11	4
1890	30·74	31	11	6	2	3
Average value of wheat-crop per acre for seven years in				} 6	0	5
Great Britain . . . . .						

As regards the other farm crops of which particulars are given, a few brief notes must suffice.

*Oats* are grown in every State and territory except Arizona; the range of yield per acre being from 34·2 bushels in Illinois, to 9·5 bushels in North Carolina. Generally speaking, the Northern and Western States grow much larger crops than the Southern States. The value per acre ranges from 3*l.* 15*s.* 7*d.* in Nevada, to 19*s.* in North Carolina.

*Rye* is grown in all the States except Arizona, Florida, Montana, Nevada, New Mexico, and Wyoming. Colorado stands first, both as regards yield and value per acre, the former being 17·1 bushels, and the latter, 2*l.* 13*s.* 3*d.* Tennessee gives the lowest value per acre (19*s.* 2*d.*), and South Carolina the lowest yield, 4·6 bushels.

*Barley* is not grown in Arkansas, Delaware, Florida, Louisiana, Mississippi, or Wyoming. In Maryland the crop has the highest value per acre (4*l.* 5*s.* 3*d.*), but several other States have a better average yield, the highest being 29·1 bushels, which is attained in far-away Washington. It will be observed that barley gives a considerably larger return per acre than wheat on the general average. If we compare the figures for each of these crops for the various States, this is still more noteworthy; practically, it is only in a few of the Northern States on the Atlantic coast—such as Maine, New Hampshire, Vermont, Massachusetts, Connecticut, &c., that wheat gives a higher return than barley. In no less than 31 out of the

40 States in which barley is grown, its value per acre is greater than that of wheat. The lowest return per acre from barley (in Nebraska) is 1*l.* 11*s.* 7*d.*, whereas the return from wheat goes as low as 1*l.* 4*s.* 9*d.*, and is less than thirty shillings in seven different States. The lowest average yield of barley is 10·4 bushels in Alabama.

*Buckwheat* is grown in 29 States. The average yield ranges from 20·8 bushels in California, to 8·5 bushels in Tennessee, and the average value from 3*l.* 5*s.* 4*d.* to 1*l.* 3*s.* 7*d.* in the same States respectively.

*Potatoes* are universally grown throughout the States. The highest average yield per acre is 117·1 bushels in Washington, and the lowest, 55 bushels in South Carolina. The average value per acre ranges from 15*l.* 17*s.* 8*d.* in Nevada, to 6*l.* 7*s.* in Tennessee.

*Tobacco* is cultivated in 17 States. Massachusetts stands first, both as regards the quantity and value of the crop. The average yield per acre is there 1485·4 lb., and its value, 42*l.* 11*s.* 2*d.* The lowest average yield is 480·8 lb., in North Carolina, and the lowest average value is 9*l.* 4*s.* 4*d.*, in Maryland. It is rather curious that Virginia, with all its tobacco traditions, stands, with the exception of Maryland, lowest on the list, both as regards yield and value.

*Cotton* is only grown in 11 States. Louisiana stands highest, with an average yield of 232·7 lb. per acre, worth 4*l.* 6*s.* 9*d.*, and Florida lowest, with a yield of 106·4 lb., worth 2*l.* 6*s.* 6*d.*

*Hay* is, of course, a universal crop. The yield ranges from 1·39 tons in California and Oregon, to 0·93 tons in New Hampshire. The value, however, bears but little relation to the yield. It is highest in Massachusetts, where it makes 3*l.* 18*s.* 5*d.*, although the yield barely exceeds a ton, and lowest in Nebraska, where a yield of nearly a third of a ton per acre more only makes 1*l.* 0*s.* 1*d.*

R. HENRY REW.

---

## THE SMUT OF ONIONS.

IN the Annual Report of the Connecticut Agricultural Experiment Station for 1889 Dr. R. Thaxter gives a description of this fungus, and also the results of experiments made by him with the object of finding some means for its prevention.

The smut of onions (*Urocystis Cepulae*, Frost) has only been recorded as causing serious disease within comparatively recent years.

It was probably observed first in Connecticut about 1860, since which time it has spread very rapidly, and has also been noticed and described by botanists both in the United States and in Europe. As to its previous history there is much uncertainty, as the fungus has not, up to the present, been found on any wild species of *Allium*, the genus of which (the onion) *Allium Cepa*, is a member.

The smut of the cultivated onion belongs to the same group of fungi as that which includes the bunt of wheat (*Tilletia Caries*, Tul.) and the smut of oats and barley (*Ustilago carbo*, Tul.) It appears on the seedling, first in the form of dark spots at different heights in the leaves, and commonly this occurs just below the knee; later, longitudinal cracks form at one side of the spots, and this part of the leaf is observed to have become a dry fibrous mass covered with a black sooty powder. Occasionally only the first leaf is attacked, and falls, when the plant may recover and come to maturity; but more frequently, as the leaves appear one after another above ground, they are found to be affected in like manner to the first, and if the plant be strong enough to resist the attack sufficiently it may grow to a considerable size, and survive until the time of harvesting. It will then be found, on pulling it up, that not only has the disease attacked the leaves, but that the bulb also has become more or less covered by black elevations running down to its base. Such onions either dry up, or rot, soon after being pulled. The black, smutty powder which thus forms on the leaves and bulb consists of the spores of the fungus. Like the spores of bunt and of smut of oats they are very minute, and do not measure more than  $\frac{7.5}{100000}$  of an inch in diameter.

In the more familiar cases of bunt and smut of our cereal crops the disease is propagated by the spores adhering to seed (see Vol. xxiv. Second Series, page 397), whereas the spores which may become distributed on the ground appear to have no further effect on crops sown on that ground. The smut of onions, on the contrary, appears to retain its power of attacking a second crop after being left in the ground by a first, and Dr. Thaxter is of opinion that the risk of the spores being carried on the seed is comparatively small. Experiments, indeed, which were made by him render it extremely probable that this is the case, and he recommends farmers to keep their agricultural implements very clean when used for tilling onion land, in order to prevent the spores from being carried from one piece of land to another.

How long the spores of the onion smut may remain dormant in the earth depends, no doubt, on the conditions of temperature and moisture in which they are placed, but it appears from the evidence which Dr. Thaxter has collected that this may be certainly more than five years.

The young onion plant is attacked almost as soon as the seed germinates, and consequently, when considering the best way in which to apply a series of fungicides, the investigator was led to the conclusion that to dress the seeds would be of no use, and that the only method would be to ensure their operation just at the time when the



seed was germinating, and in the experiments about to be described the fungicides were sown in the drills with the seed.

The first series of experiments was made in boxes in a hot-house, when in two cases sulphate of iron and sulphate of copper were respectively sown with the seed; in a third case the seed was sown alone. Where the sulphates of copper and iron were applied, they were, on one-half of each plot, sown *on* the drill, in the other half *in* it. As a result, the application of sulphate of copper proved to be almost as injurious to the young onion plant as to the smut, and was quite worthless on this account. In the case of sulphate of iron, where it was applied *in* the drill it showed itself to be a fairly good fungicide, without causing the disastrous results to the onion plants which accompanied the sulphate of copper application; when sown

	Number of grams used per row	Average number of plants per row May 11	Average number of sound onions pulled August 6	Average weight per row of sound onions weighed August 9
Top-dressed with sulphate of iron . . . . .	30	98.8	11.6	—
Seed treated with "Germinator" . . . . .	—	100.2	8.4	—
Sulphide of sodium in drills . . . . .	10	90.8	29.8	—
Sulphide of sodium in drills . . . . .	5	98.6	38.8	—
Hyposulphite of sodium in drills . . . . .	20	73.2	11.2	—
Hyposulphite of sodium . . . . . Air-slaked lime . . . . .	10	90.6	27	—
Flowers of sulphur . . . . . Air-slaked lime . . . . .	10	106.6	35.4	70.8
Flowers of sulphur . . . . . Air-slaked lime . . . . .	5	100.4	31.6	58.4
Sulphate of copper . . . . . Air-slaked lime . . . . .	10	71.4	17.4	—
Sulphate of copper . . . . . Air-slaked lime . . . . .	5	84.2	10	—
Sulphate of iron in drills . . . . .	20	72.2	58.6	—
Sulphate of iron . . . . . Air-slaked lime . . . . .	5	78.2	38.6	—
Average of alternate rows untreated . . . . .	—	94.3	18.5	—

on the drill, however, the effect of the iron salt was very much less apparent.

The second experiment was made in a field on a farm which had been "wholly run out by smut in the previous year." The seed was sown in drills 10 feet long and 1 foot apart. Every alternate row was left undressed for the sake of comparison, and the fungicides were applied to series of five alternate rows. The results are recorded in the table on the preceding page.

Although the author does not consider the results of these experiments as at all satisfactory, there are, nevertheless, one or two conclusions which may be drawn from them:—

(a) The patent "Germinator" which has been recommended in the United States as a preserver of seeds of all kinds, and is said to act effectually on "the globular-formed dust which participates in the formation of blight, of heat, of ergot of rye," &c., appears to have but little effect on the smut of onions. The application of sulphate of copper is, for the reason previously stated, equally inefficacious.

(b) Applications of sulphate of iron *in* the drill, either with or without slaked lime, and of flowers of sulphur and air-slaked lime, and lastly of sulphide of sodium, appear to be all possessed of the property of destroying the smut, and thus of protecting the young onion plant during its early stages of growth.

J. W. LEATHER.

---

## RECENT AGRICULTURAL INVENTIONS.

*The subjects of Applications for Patents from June 18, 1891, to  
Sept. 12, 1891.*

N.B.—Where the Invention is a communication from abroad, the name of the Inventor is shown in italics, between parentheses, after the name of the applicant.

### Agricultural Machinery and Implements, &c.

No. of Application.	Name of Applicant.	Title of Invention.
9674	BURGESS, W. J.	Picking up potatoes from the soil.
9703	FISCHER, J. E. A.	Manure-distributing machine.
9841	COOKE, W.	Ridging and earthing ploughs.
9870	DARBY & STEVENSON	Implements for cultivating land.
9898	RIEGER, C.	Turnip-cutting machines.
9978	YATES & BASFORD	Plough beams.
10326	SARGEANT, T. C.	Seed-drills.
11141	HORNSBY & INNOCENT	Steering-gear for ditto.

No. of Application.	Name of Applicant.	Title of Invention.
11431	ROBINS, W. & A. . .	. Machine for picking up corn and conveying it to binding apparatus.
11492	BAWDEN, R. . .	. Ploughshares.
11517	PERKINS, J. E. S. . .	. Hay-making machines.
11850	PURDON, J. . .	. Scuffling hoe.
12088	COTTON, G. . .	. Hand-roller and sowing machine.
12206	WELLS, F. . .	. Wind screen for hay, &c. elevators.
12319	TODD, F. E. . .	. Sheaf-binding harvester.
12395	EDWARDS, E. ( <i>Nauman</i> )	Spreading manure and sowing seed.
12399	STENNER, J. & R. . .	. Hay tedder.
12608	BLACKSTONE, E. C. . .	. Hay-making machine.
12767	HILL, J. . .	. Mowing and reaping machines.
12874	POOL, W. H. . .	. Hay-collectors or horse-rakes.
12902	HOWARD & GIBBS . . .	. Harvesting machines.
13176	HOLT, J. . .	. Tool for binding corn by hand.
13240	HANCOCK, C. A. . .	. Ploughs.
13306	LISTER, H. B. & R. . .	. Machinery for cleaning wheat.
13378	BRIGGS & WEST . . .	. Machinery for screening corn.
13380	GREAVES, J. E. . .	. Guards for mowing and reaping machines.
13515	PERKINS, J. E. S. . .	. Hay-making machines.
13543	WHITAKER, J. . .	. Apparatus for sharpening mowing machine knives.
13858	BURGESS, C. T. . .	. Reaping and mowing machines.
13928	MARTH, O. . .	. Plough.
13946	WILSON, A. . .	. Automatic feed-cutter.
13997	SAMUELSON . . .	. Hopper of "Gardner" turnip-cutters.
14240	HILL, T. . .	. Mechanical hay-maker.
14671	TELFORD, S. . .	. Self-balancing steel turnover horse hay-rake.
15046	HARDINGHAM ( <i>McCormick</i> ) . . .	. Grain-binding harvesters.
15148	SABINE, T. . .	. Conveying straw, cavings, &c., from threshing machines to attendant chaff-cutters.
15151	MAYNARD, R. . .	. Bagging apparatus of portable combined chaff-cutting engines.
15158	HILL, T. . .	. Ploughs.
15313	EDDLESTONE, T. . .	. Mowing and reaping machines.
15465	SARGEANT, T. C. . .	. Harvesters.

### Stable Utensils and Fittings—Horse-shoes, &c.

9845	BALLARD, W. W. . .	. Horse-shoes.
9873	SCHULZ and another . . .	. Curry-combs.
9969	ASH, T. . .	. Ladies' riding-saddles.
9994	HUGHES, E. T. ( <i>Koehler</i> ) . . .	. Elastic reins.
10317	FELL, W. T. . .	. Horse-collars.
10501	ORPWOOD, W. L. . .	. Bits for pulling horses,

No. of Application.	Name of Applicant.	Title of Invention.
10564	WOOLLATT, T. L.	. Single gullet for saddle-trees.
10924	BOURY and others	. Bits.
11322	METAXA, E.	. Detaching horses from carriage in cases of danger.
11547	WILLIS, F.	. Beads of harness saddles.
11751	DAVIES, G.	. Stocks for farriery or veterinary purposes.
11997	RENNIE & CHRISTIE	. Horse-shoes.
12105	JACKSON & BOOTH	. Composite horse-shoe.
12246	WILLIAMSON, H. W.	. Automatic appliance for horses' nose-bags.
12353	JOY, H.	. Safety horse-shoe.
12502	ELLIOTT, R. P.	. Folding stirrup-iron.
12704	WHEWAY, S. B.	. Hames for horse-collars.
12764	CHURCH & KENT	. Pneumatic horse-collar.
12835	NIEDERER, A.	. Horse-cleaning apparatus.
13263	DYMOND, G. C.	. Releasing traces of carriage horses.
13819	WHATLING, W.	. Horse-shoes.
13839	GROUT, D. F.	. Harness tug.
13972	SHEPHERD, F.	. Releasing fallen horses from shafts or pole of vehicles.
13993	BARRADALE, I.	. Drain pipe or gutter for stables.
14266	HUMM, M. & A. E.	. Curative administration of electricity to horses.
14268	FULFORD, W.	. Detached sliding pommel for ladies' saddles.
14726	LAVENDER, G. L.	. Reversible horn for ladies' saddles.
14863	HEERMANCE, DE W.	. Saddles.
14955	HASLAM, J. N.	. Footpads for horses.
15023	DEWSBURY, R.	. Harness saddles.
15314	MORRIS, M.	. Safety horse-collar to prevent slipping.

### **Carts and Carriages.**

9827	BRIGGS & DUNN	. Wheels for carriages.
10486	WRIGHT, W.	. Locking wheels.
14683	MALLET, C.	. Whip sockets.
15007	KIMPTON & HARE	. Hinges for falling hoods of carriages.
15335	HAEGELE and another	. Carriage lamps.

### **Dairy Utensils, &c.**

9823	SANDERS, R. M. D.	. Combination milk-vessel for transit and delivery of milk.
9910	PROCTOR, D.	. Milking-machines.
10259	SHIELDS & ELLIOT	. Pulsating apparatus for use with teats of milking-machines.
10381	GRAY, J.	. Milking devices.

No. of Application.	Name of Applicant.	Title of Invention.
10492	LAIDLAW, J. . . .	Centrifugal apparatus for testing samples of milk.
11810	HARTLAND, W. H. H. . . .	Cheese-cutter.
11875	NIELSEN, J. . . .	Milking machines.
12092	HANSEN & CLARK . . . .	Centrifugal cream generators and churns used therewith.
12127	FITZPATRICK ( <i>Sinn</i> ) . . . .	Butter-making machine.
12293	IRONS, J. W. . . .	Cheese-turning racks and shelves.
12549	DUNCAN, J. H. H. . . .	Production of butter.
12692	MCMORRAN and another . . . .	Milking apparatus.
13614	MARTINET, G. . . .	Churn.
14239	NORCOTT, F. H. . . .	Milk-pans.
14838	DUNCAN, J. H. H. . . .	Cream separators.
14917	PETTER, J. B. . . .	Oscillating trough for use in cheese-making.

### Poultry and Game, &c., Appliances.

9886	WHITE, H. . . .	Feeding and drinking apparatus for poultry, &c.
10879	GOOD & SHAW . . . .	Self-acting egg-turning machine for incubators.
12371	MELLINGER, T. G. . . .	Poultry-plucking machines.
12645	SULLIVAN, W. H. . . .	Incubators.
13087	ELTON, A. M. . . .	Maintaining uniform temperature in incubators.
13580	CASHMORE, C. . . .	Incubators.
14628	WILSON, T. . . .	Apparatus for raising of poultry, &c.
15415 } 15416 }	GLOVER & DEACON . . . .	Vapour incubator.

### Miscellaneous.

10247	GIRAUD, B. T. . . .	Paving and draining of pigstyes, stables, byres, &c.
10378	STURZENEGGER, J. . . .	Dog-kennels, &c.
10485	JUDE & EVERITT . . . .	Appliance to prevent goring in cattle.
10542	KELLY, E. . . .	Portable sheep-dipping apparatus.
10794	LAWSON, G. . . .	Fixing show medals on prize-winning animals.
10954	MCDONALD, A. . . .	Tethers.
11662	KERR, W. . . .	Cutting hedges.
12458	HORN, W. W. ( <i>Ruser</i> ) . . . .	Compound for dehorning cattle.
12476	MOFFAT, J., and another . . . .	Shearing and clipping wool.
12524	ANDREWS, L. . . .	" " " "
12773	RAKE, G. S. . . .	Feeding bees.
13212	TALLERMAN, D. . . .	Cattle food.
13505	MCDONALD, A. . . .	Tethers.

No. of Application.	Name of Applicant.	Title of Invention.
13656	GILLIES, J. M.	Beehives.
13746	HARVEY, G. A.	Queen and drone excluder for beehives.
14840	BELL, E. W.	Sheep dip.
15091	FERGUSON, G. C.	Beehive attachment.
15452	DAUPHINAIS, A.	Device for hitching animals.

### Numbers of Specifications relating to the above subjects Published since June 16, 1891<sup>1</sup>

(with prices in parentheses).

#### Specifications of 1890.

8003 (8*d.*), 9589 (8*d.*), 10083 (8*d.*), 10126 (6*d.*), 10191 (6*d.*), 10238 (8*d.*), 10412 (6*d.*), 10583 (6*d.*), 10973 (6*d.*), 11145 (8*d.*), 11568 (8*d.*), 11812 (8*d.*), 11822 (8*d.*), 11825 (6*d.*), 11957 (6*d.*), 12038 (6*d.*), 12339 (6*d.*), 12700 (6*d.*), 12709 (8*d.*), 12984 (4*d.*), 12988 (8*d.*), 13096 (8*d.*), 13242 (8*d.*), 13246 (6*d.*), 13452 (6*d.*), 13513 (6*d.*), 13539 (6*d.*), 13632 (6*d.*), 13935 (6*d.*), 14027 (6*d.*), 14095 (6*d.*), 14303 (6*d.*), 14492 (8*d.*), 14495 (6*d.*), 14728 (6*d.*), 14772 (8*d.*), 14773 (6*d.*), 14782 (8*d.*), 14788 (6*d.*), 14968 (8*d.*), 15073 (6*d.*), 15157 (6*d.*), 15376 (6*d.*), 15565 (8*d.*), 15628 (6*d.*), 15700 (6*d.*), 15968 (8*d.*), 16068 (6*d.*), 16492 (8*d.*), 16933 (6*d.*), 16944 (6*d.*), 17314 (6*d.*), 17535 (8*d.*), 19042 (4*d.*), 19399 (6*d.*), 20060 (6*d.*), 21068 (11*d.*).

#### Specifications of 1891.

5117 (6*d.*), 5762 (6*d.*), 5966 (8*d.*), 6015 (6*d.*), 6523 (6*d.*), 6842 (6*d.*), 6875 (8*d.*), 6930 (6*d.*), 7249 (6*d.*), 8171 (6*d.*), 8256 (8*d.*), 8321 (8*d.*), 8331 (6*d.*), 8411 (6*d.*), 8451 (6*d.*), 9619 (6*d.*), 9873 (6*d.*), 9885 (6*d.*), 11074 (6*d.*), 11291 (6*d.*), 11535 (6*d.*).

---

<sup>1</sup> Copies may be obtained at the Patent Office (Sale and Store Branch), 38 Cursitor Street, London, E.C.

## STATISTICS AFFECTING BRITISH AGRICULTURAL INTERESTS.

### SUMMARY OF AGRICULTURAL RETURNS OF GREAT BRITAIN FOR 1891.

*Note.—The Returns were collected on June 4 in the Years 1889, 1890, and 1891.*

#### ACREAGE OF LAND IN GREAT BRITAIN UNDER—

Year	Wheat	Barley	Oats	Potatoes	Hops
	Acres	Acres	Acres	Acres	Acres
1889 . . . . .	2,449,354	2,121,530	2,888,704	579,222	57,724
1890 . . . . .	2,386,336	2,111,178	2,902,998	529,661	53,916
1891 . . . . .	2,307,277	2,112,798	2,899,129	532,794	56,148
1891 compared with 1890	Increase	1,620 or 0·1 per cent.	—	3,133 or 0·6 per cent.	2,187 or 4·1 per cent.
	Decrease	79,059 or 3·3 per cent.	—	3,869 or 0·1 per cent.	—
1891 compared with 1889	Increase	—	—	10,425 or 0·4 per cent.	—
	Decrease	142,077 or 5·8 per cent.	8,732 or 0·4 per cent.	—	46,428 or 8·0 per cent.
				1,576 or 2·7 per cent.	

#### NUMBER OF CATTLE IN GREAT BRITAIN.

YEAR	CATTLE			
	Cows and heifers in milk or in calf	2 years old and above	Under 2 years old	Total
	No.	No.	No.	No.
1889 . . . . .	2,433,639	1,453,859	2,252,057	6,139,555
1890 . . . . .	2,537,990	1,439,119	2,531,523	6,508,632
1891 . . . . .	2,657,054	1,504,649	2,691,118	6,852,821
Increase in 1891 compared with 1890 . .	119,064 or 4·7 per cent.	65,530 or 4·6 per cent.	159,595 or 6·3 per cent.	344,189 or 5·3 per cent.
	223,115 or 9·2 per cent.	50,790 or 3·5 per cent.	459,061 or 19·5 per cent.	713,266 or 11·6 per cent.

SUMMARY OF AGRICULTURAL RETURNS, &c.—*Continued.*

## NUMBER OF SHEEP AND PIGS IN GREAT BRITAIN.

YEAR	SHEEP AND LAMBS			PIGS
	Sheep	Lambs	Total	
	No.	No.	No.	No.
1889 . . . . .	15,862,132	9,769,888	25,632,020	2,510,803
1890 . . . . .	16,756,568	10,515,891	27,272,459	2,773,609
1891 . . . . .	17,786,941	10,945,617	28,732,558	2,888,773
Increase in 1891 compared with 1890 . . . . .	1,030,373 or 6·1 per cent.	429,726 or 4·1 per cent.	1,460,099 or 5·4 per cent.	115,164 or 4·2 per cent.
Increase in 1891 compared with 1889 . . . . .	1,924,809 or 12·1 per cent.	1,175,729 or 12·0 per cent.	3,100,538 or 12·1 per cent.	377,970 or 15·1 per cent.

TABLE SHOWING THE ACREAGE UNDER HOPS IN ENGLAND, AS RETURNED UPON JUNE 4, IN THE YEARS 1889, 1890, AND 1891.

COUNTIES	1889	1890	1891	COUNTIES	1889	1890	1891
	acres	acres	acres		acres	acres	acres
Berks . . . . .	10	11	11	Salop . . . . .	101	98 <sup>1</sup>	112
Cambridge . . . . .	—	—	3	Suffolk . . . . .	29	25 <sup>1</sup>	20
Gloucester . . . . .	4	11 <sup>1</sup>	25	Surrey . . . . .	2,101	1,874	1,955
Hants . . . . .	2,905	2,614	2,752	Sussex . . . . .	7,282	6,787	7,150
Hereford . . . . .	6,850	6,077 <sup>1</sup>	6,560	Worcester . . . . .	2,939	2,925 <sup>1</sup>	3,280
Kent . . . . .	35,187	33,525	34,266				
Notts . . . . .	16	11	14	Total . . . . .	57,724	53,961 <sup>1</sup>	56,148

<sup>1</sup> These acreages do not agree with those given in the "Agricultural Returns" of 1890 (see Journal, Vol. I., 3rd Series, 1890, p. 672), owing to 3 acres in the county of Gloucester and 4 acres in the county of Suffolk having been originally returned in error, and to the returns for parts of the counties of Hereford, Salop, and Worcester having been originally made in hop acres instead of statute acres, causing a reduction of 442 acres in Hereford, 12 in Salop, and 133 in Worcester.



# JOURNAL

OF THE

## ROYAL AGRICULTURAL SOCIETY OF ENGLAND.

---

### THE SOURCES OF THE NITROGEN OF OUR LEGUMINOUS CROPS.

#### CONTENTS.

INTRODUCTION . . . . .	657
EARLIER EXPERIMENTS, WHICH DID NOT SHOW FIXATION OF FREE NITROGEN . . . . .	666
RECENT EXPERIMENTS, WHICH DO SHOW FIXATION OF FREE NITRO- GEN . . . . .	669
THE VEGETATION EXPERIMENTS IN 1888 . . . . .	670
THE VEGETATION EXPERIMENTS IN 1889, 1890, AND 1891 . . . . .	678
DIFFERENCE IN THE EXTERNAL CHARACTER OF LEGUMINOUS ROOT- NODULES . . . . .	687
HOW IS THE FIXATION OF NITROGEN TO BE EXPLAINED? . . . . .	689
OF WHAT IMPORTANCE TO AGRICULTURE IS THE NEWLY-RECOGNISED SOURCE OF NITROGEN TO LEGUMINOUS CROPS? . . . . .	696

#### INTRODUCTION.

It happens that the agricultural plants belonging to the great family of the *Leguminosæ* are all included within the sub-order *Papilionaceæ*. But as the terms *Leguminosæ* and *leguminous* are better known in agricultural discussions they will be adopted throughout this article. It will be seen farther on, however, that the limitation which the use of the terms *Papilionaceæ* and *papilionaceous* would imply, may possibly in the course of future investigation prove to be more appropriate, especially

when the subject of the sources of the nitrogen of the plants of the different sub-divisions is in question (see p. 687).

There can be no doubt that both the scientific interest and the practical value of our leguminous crops depend very much on the amount of nitrogen which they contain, and on the sources of their nitrogen; and especially on the great differences in these respects between them and the representatives of the other families of plants with which they are grown, either in alternation in our rotations, or in association in our meadows and pastures.

It is well known that, under the conditions in which crops are grown in ordinary agriculture, nitrogenous manures have very direct effects in increasing the produce of wheat, of barley, and of oats, of turnips, of mangel, and of potatoes. This is the case, notwithstanding that in the cereals the increased produce consists characteristically of the non-nitrogenous substances starch and cellulose; in the root-crops of the non-nitrogenous substance sugar; and in potatoes of the non-nitrogenous substance starch. Leguminous crops, on the other hand, not only as a rule accumulate much more nitrogen over a given area of land under equal soil conditions, and contain a higher percentage of nitrogen in their dry substance, than the crops above enumerated, but there is abundant evidence that they also derive much nitrogen from the combined nitrogen of the soil and subsoil, and further that they probably take up much as nitric acid; yet it is generally recognised in practical agriculture that direct nitrogenous manures have comparatively little effect in increasing the produce of such crops.

The influence of nitrogenous manures in increasing the production of the non-nitrogenous constituents of our crops is very strikingly illustrated by the results given in Table I. (p. 659).

The calculations are based on the average produce obtained in the experiments at Rothamsted by the different manures—of wheat over twenty years, of barley over twenty years, of sugar-beet over three years, of mangel-wurzel over eight years, of potatoes over ten years, and of beans over eight years.

As will be seen, the Table shows—the estimated amounts of carbon, per acre per annum, in the total produce (grain and straw) of wheat, and of barley, in the roots of sugar-beet and of mangel-wurzel, in the tubers of potatoes, and in the total produce (corn and straw) of beans, when each is grown by a complex mineral manure without nitrogen, and also when grown with the same mineral manure with nitrogenous manures in addition. Next is shown the estimated gain of carbon, that is, the increased amount of it accumulated in the crop under the influence of the

TABLE I.—Estimates of the Yield and Gain of Carbon, and of the Increased Produce of Carbohydrates, per acre per annum, in various Crops.

	Carbon		Carbohydrates	
	Actual	Gain	Gain	For 1 lb. nitrogen in manure
<i>Wheat twenty years, 1852-71.</i>				
Mineral manure . . . . .	lb. 988	lb. —	lb. —	lb. —
"    "    and 43 lb. nitrogen as ammonia . . . . .	1,590	602	1,240	28.8
Mineral manure and 86 lb. nitrogen as ammonia . . . . .	2,222	1,234	2,550	29.7
Mineral manure and 86 lb. nitrogen as nitrate . . . . .	2,500	1,512	3,140	36.5
<i>Barley twenty years, 1852-71.</i>				
Mineral manure . . . . .	1,138	—	—	—
"    "    and 43 lb. nitrogen as ammonia . . . . .	2,088	950	1,992	46.3
<i>Sugar-beet three years, 1871-73.</i>				
Mineral manure . . . . .	1,123	—	—	—
"    "    and 86 lb. nitrogen as ammonia . . . . .	2,600	1,477	3,188	37.1
Mineral manure and 86 lb. nitrogen as nitrate . . . . .	3,031	1,908	4,052	47.1
<i>Mangel-wurzel eight years, 1876-83.</i>				
Mineral manure . . . . .	759	—	—	—
"    "    and 86 lb. nitrogen as ammonia . . . . .	1,889	1,130	2,376	27.6
Mineral manure and 86 lb. nitrogen as nitrate . . . . .	2,129	1,370	2,771	32.2
<i>Potatoes ten years, 1876-85.</i>				
Mineral manure . . . . .	1,021	—	—	—
"    "    and 86 lb. nitrogen as ammonia . . . . .	1,783	762	1,507	17.5
Mineral manure and 86 lb. nitrogen as nitrate . . . . .	1,752	731	1,416	16.5
<i>Beans eight years, 1862 and 1864-70</i>				
Mineral manure . . . . .	726	—	—	—
"    "    and 86 lb. nitrogen as nitrate . . . . .	992	266	474	5.5

nitrogenous manures. The estimated increased production of total carbohydrates, under the influence of the nitrogenous manures, is then given; and lastly, the estimated gain of carbohydrates for 1 lb. of nitrogen supplied in manure. Such estimates can obviously be only approximations to the truth; but accepted as such, they are of interest and of use, as conveying some definite impression of the influence of nitrogenous manures on carbon-assimilation, and on carbohydrate-formation.<sup>1</sup>

It is seen that, independently of the underground growth, the wheat was estimated to assimilate 988 lb. of carbon per acre per annum, under the influence of a complex mineral manure alone; and that the amount was increased to 1,590 lb. by the addition of 43 lb. of nitrogen as ammonium-salts, to 2,222 lb. by 86 lb. of nitrogen as ammonium-salts, and to 2,500 lb. by 86 lb. of nitrogen as sodium-nitrate. Accordingly, as shown in the second column, the increased assimilation of carbon was, by 43 lb. of nitrogen as ammonium-salts 602 lb., by 86 lb. as ammonium-salts 1,234 lb., and by 86 lb. as sodium-nitrate 1,512 lb.

Reckoned in the same way, the increased assimilation of carbon in the barley was, for 43 lb. of nitrogen as ammonium-salts, 950 lb. per acre; that is, one-and-a-half time as much as by the same application in the case of wheat.

In the sugar-beet the increased assimilation of carbon, and accumulation of it in the roots, was 1,477 lb. per acre by the application of 86 lb. of nitrogen as ammonium-salts, and 1,908 lb. by 86 lb. of nitrogen as sodium-nitrate. There was, therefore, more increased assimilation of carbon and accumulation of it in the roots of the sugar-beet, than in the grain and the straw of wheat, by the same applications of nitrogenous manure.

In the mangel-wurzel the increased accumulation of carbon in the roots was 1,130 lb. by 86 lb. of nitrogen as ammonium-salts, and 1,370 lb. by 86 lb. as nitrate; that is, less than in the removed crops (corn and straw) of wheat, and considerably less than in the removed crops (the roots) of sugar-beet.

In the potatoes, reckoned on the increased production of tubers only (the tops being left on the land), the increased yield of carbon by 86 lb. of nitrogen as ammonium-salts was 762 lb.

---

<sup>1</sup> The mode of calculating the amounts of carbon and of carbohydrates is as follows:—From the amount of dry substance in the crops the amounts of mineral matter and of nitrogenous substance are deducted, and the remainder represents approximately the amount of carbohydrates. The amount of carbon in the nitrogenous substance is calculated; and then that in the carbohydrates, on the assumption that, in the wheat, barley, and beans, starch and cellulose are the main products; in the sugar-beet and mangel-wurzel, cane-sugar, pectine, and cellulose; and in the potatoes, starch and cellulose.

per acre, and by 86 lb. as sodium-nitrate 731 lb. That is to say, there was considerably less increased production of starch in potatoes than of sugar in sugar-beet or mangel-wurzel, by the same applications of nitrogenous manure.

Lastly, in the leguminous crop—beans, with its high yield of nitrogen per acre, and the high percentage of nitrogen in its dry substance—the increased assimilation of carbon under the influence of nitrogenous manure was, comparatively, quite insignificant. Thus, there was, by the application of 86 lb. of nitrogen as sodium-nitrate, an increased assimilation of carbon of only 266 lb. per acre; or little more than one-sixth as much as in wheat, and little more than one-eighth as much as in sugar-beet, by the same application.

Turning to the figures in the third column of the Table on page 659, it is seen that there was a very greatly increased production of the non-nitrogenous bodies—the carbohydrates—by the use of nitrogenous manures.

Thus, by the use of 43 lb. of nitrogen as ammonium-salts, there was an estimated increase of 1,240 lb. of carbohydrates in the grain and straw of wheat, and of 1,992 lb. in those of barley. By the application of 86 lb. of nitrogen as ammonium-salts, there was an increased formation of 2,550 lb. of carbohydrates in wheat, of 3,188 lb. in sugar-beet, of 2,376 lb. in mangel-wurzel, and of only 1,507 lb. in potatoes; and when 86 lb. were applied as sodium-nitrate, there was an increased production of 3,140 lb. in wheat, of 4,052 lb. in sugar-beet, of 2,771 lb. in mangel-wurzel, and of only 1,416 lb. in potatoes; whilst, compared with these amounts, there was in beans, by the same application, an increase of only 474 lb. of carbohydrates.

The last column shows the estimated increased amounts of carbohydrates produced, for 1 lb. of nitrogen supplied in manure, in the different cases. Thus, when 43 lb. of nitrogen were applied as ammonium-salts, 1 lb. of nitrogen in manure gave an increased production of 28·8 lb. of carbohydrates in the grain and straw of wheat, and of 46·3 lb. in those of barley; when 86 lb. were applied as ammonium-salts, 1 lb. gave an increase of 29·7 lb. carbohydrates in wheat, 37·1 lb. in sugar-beet, 27·6 lb. in mangel-wurzel, and 17·5 lb. in potatoes. Again, when 86 lb. were applied as sodium-nitrate, 1 lb. gave an increase of 36·5 lb. carbohydrates in wheat, 47·1 lb. in sugar-beet, 32·2 lb. in mangel-wurzel, 16·5 lb. in potatoes, and only 5·5 lb. in the leguminous crop—beans.

Thus, then, we have the apparently anomalous result, that the crops which are characterised by yielding a comparatively small amount of nitrogen over a given area, by containing a com-

paratively low percentage of nitrogen in their dry substance, and by yielding comparatively large amounts of the *non-nitrogenous* products—starch, sugar, and cellulose—are especially benefited by the application of nitrogenous manures, and under their influence yield greatly increased amounts of those *non-nitrogenous* bodies; whilst the leguminous crops, which contain a much higher percentage of nitrogen, and yield much more nitrogen over a given area of land, under the same soil and season conditions, are much less benefited by such manures.

Without attempting to give an adequate physiological explanation of this curious result, some of the facts bearing upon it may be briefly stated as follows: The *non-leguminous* crops having comparatively limited power of accumulating nitrogen under given soil conditions, they generally require nitrogenous manuring; the amount of nitrogen assimilated to a great extent rules the amount of chlorophyll formed; chlorophyll formation is an essential condition of carbon assimilation; the amount of carbon assimilated is the chief measure of the amount of produce; and since the more special or characteristic products of the *non-leguminous* crops are the *non-nitrogenous* substances—the carbohydrates, the natural result of the increased assimilation of nitrogen, and the consequent increased luxuriance, is an increased formation of the bodies which are their essential or characteristic products.

The fact is, that whilst it can hardly be said that there remains an unsolved problem in the matter of the sources of the nitrogen of our *non-leguminous* crops—of wheat, of barley, and of grasses, as representatives of the great family of the *Gramineæ*; of turnips, representing the *Cruciferae*; of some varieties of beet, representing the *Chenopodiaceæ*; and of potatoes of the *Solaneæ*—it must be admitted to be quite otherwise so far as our leguminous crops are concerned.

It is nearly a century ago since the question whether plants took up, or evolved, free nitrogen became a matter of experiment and of discussion; and it is just about half a century since Boussingault commenced experiments to determine whether plants assimilate free nitrogen. From his results he concluded that they did not; and those obtained at Rothamsted about thirty years ago confirmed the conclusions of Boussingault. In fact, we concluded that under the conditions of those experiments, which were those of sterilisation and enclosure, in which therefore the action both of electricity and of microbes was excluded, the results were conclusive against the supposition that, under such conditions, the higher chlorophyllous plants can directly fix free nitrogen, either by their leaves or otherwise.

It may, in fact, we think, be concluded that, at any rate in the case of our gramineous, our cruciferous, our chenopodiaceous, and our solaneous crops, free nitrogen is not the source. Nevertheless, we have long admitted that existing evidence was insufficient to explain the source of the whole of the nitrogen of the *Leguminosæ*; that there was, in fact, a missing link!

According to some even recent experimenters, however, gain of nitrogen is not limited to our leguminous crops; and the modes of explanation of the gains which have been observed are extremely various. Thus it has been assumed: that *combined* nitrogen was absorbed from the air, either by the soil or by the plant; that there is fixation of free nitrogen within the soil by the agency of porous and alkaline bodies; that there is fixation by the plant itself; that there is fixation within the soil by the agency of electricity; and, finally, that there is fixation under the influence of micro-organisms within the soil, both with and without the accompanying growth of higher plants.

Limiting our discussion here mainly to the question of the sources of the nitrogen of the *Leguminosæ*, it may be said that this has been the subject of experiment and of controversy for about half a century, and it is generally admitted that all the evidence that has been acquired, on lines of inquiry until recently followed, has failed to solve the problem. During the last few years, however, the discussion has assumed a somewhat different aspect. The question still is, whether free nitrogen is an important source of the nitrogen of vegetation generally, but especially of the *Leguminosæ*; but whilst few now assume that the higher chlorophyllous plants directly assimilate free nitrogen, it is nevertheless supposed to be brought under contribution in various ways; but especially by being brought into combination under the influence of micro-organisms, or of other low forms, either within the soil itself, or in symbiotic growth with a higher plant.

Of all the recent results bearing upon the subject, those of Hellriegel and Wilfarth with certain leguminous plants seem to us to be by far the most definite and significant; pointing to the conclusion that, although the higher chlorophyllous plants may not directly utilise free nitrogen, some of them, at any rate, may acquire nitrogen brought into combination under the influence of lower organisms; the development of which is, apparently, in some cases a coincident of the growth of the higher plant whose nutrition they are to serve.

It was in the Agricultural Chemistry Section of the "Naturforscher Versammlung" held in Berlin, in 1886, when one of

ourselves happened to be presiding, that Professor Hellriegel first announced his new results. Quite consistently, not only with common experience in agriculture, but also with the direct experimental results of ourselves and others, Hellriegel found, in his experiments, that plants of the gramineous, the chenopodiaceous, the polygonaceous, and the cruciferous families depended on combined nitrogen supplied within the soil. On the other hand, he found that leguminous plants did not depend entirely on such supplies. His results were, indeed, not only very definite, but it is seen that they had a special bearing on the admittedly unsolved problem of the source of the whole of the nitrogen of leguminous crops.

Hellriegel's experiments and results may be briefly described as follows:—In 1883 he commenced a comprehensive series of vegetation experiments in pots, in which he grew agricultural plants of various families in washed quartz sand. To all the pots nutritive solutions, but containing no nitrogen, were added. To one series nothing else was supplied; to a second a fixed quantity of nitrogen as sodium-nitrate was added; to a third twice as much; and to a fourth, four times as much. The result was that, in the case of the *Gramineæ*, and some other plants, the growth was largely proportional to the combined nitrogen supplied, whilst in that of the *Leguminosæ* it was not so. In the case of these plants—that of peas, for example—it was observed that, in a series of pots to which no nitrogen was added, most of the plants were apparently limited in their growth by the amount of nitrogen which the seed supplied. Here and there, however, a plant growing under ostensibly the same conditions grew very luxuriantly; and, on examination, it was found that whilst no nodules were developed on the roots of the plants of limited growth, they were abundant on those of the luxuriantly grown plants.

In view of this result, Hellriegel, with his colleague, Dr. Wilfarth, instituted experiments to determine whether, by the infection of the soil with appropriate organisms, the formation of the root-nodules and luxuriant growth could be induced; and whether, by the exclusion of such infection, the result could be prevented. To this end, they added to some of a series of experimental pots, 25 cubic centimetres, or sometimes 50 cubic centimetres, of the turbid watery extract of a fertile soil, made by shaking a given quantity of it with five times its weight of distilled water, and then allowing the solid matter to subside. In some cases, however, the extract was sterilised. In those in which it was not sterilised, there was almost always luxuriant growth, and abundant formation of root-nodules; but with



sterilisation there was no such result. Consistent results were obtained with peas, vetches, and some other *Leguminosæ*; but the application of the same soil-extract had little or no effect, in the case of lupins, serradella, and some other plants of the family, which are known to grow more naturally on sandy than on loamy or rich humus soils. Accordingly, they made a similar extract from a diluvial sandy soil, where lupins were growing well, in which it might be supposed that the organism peculiar to such a soil would be present; and, on the application of this to a nitrogen-free soil, lupins grew in it luxuriantly, and nodules were abundantly developed on their roots.

Further particulars of the experiments of Hellriegel and Wilfarth, and also of the results and conclusions of Berthelot, Dehérain, Joulie, Dietzell, Frank, Emil von Wolff, and Atwater, as well as of some of the later experiments of Boussingault which have a bearing on the present aspect of the question, will be found in our paper in the *Philosophical Transactions*, Vol. 180 (1889), B. A short account is also given of the experiments of Bréal, confirming the results of Hellriegel, in our paper in the "*Proceedings of the Royal Society*," Vol. 47, 1890.

Thus, then, not only did Hellriegel and Wilfarth get negative results with plants of other families than the *Leguminosæ*, as all experience would lead us to expect, but they obtained positive results with the *Leguminosæ*, in regard to the source of the whole of the nitrogen of which experience showed that there was a "missing link." Such results were obviously of fundamental and of far-reaching importance; and it seemed desirable that the subject should be further investigated with a view to their confirmation or otherwise. Accordingly, it was decided to take it up at Rothamsted, and it was hoped to commence experiments in 1887, but it was not possible to do so until 1888. In that year, a preliminary series was undertaken; the investigation was continued in 1889 and 1890, and is, in fact, still in progress.

It is proposed to give in the following pages some account of the conditions and of the results of these recent experiments made at Rothamsted, which do show a fixation of free nitrogen. But, before doing so, it will be well to call attention to those of the earlier experiments, which did not indicate any fixation; as the well-defined difference in the conditions under which such different results were obtained will bring clearly to view what are the conditions under which fixation does, and what are those under which it does not, take place. We shall thus, too, be the better able to form some judgment as to the practical bearing of the recent results.

EARLIER EXPERIMENTS, WHICH DID NOT SHOW FIXATION  
OF FREE NITROGEN.

It has already been stated that the results and conclusions of Boussingault were against the supposition that plants assimilate the free nitrogen of the atmosphere. His numerous experiments on the subject were commenced in 1837, and were continued at intervals up to 1858. In all cases the substances he used as soil were sterilised; in some the supplied air was washed; whilst in others the plants grew in limited air, or were more or less protected. He experimented with a great variety of plants—wheat and oats representing *Gramineæ*; clover, peas, haricots, and lupins as *Leguminosæ*; also garden cress and sunflower.

In some of his earlier experiments, conducted in free air in a summer-house, the leguminous plants, trefoil and peas, did indicate some gain of nitrogen; but in all the subsequent experiments there was generally either a slight loss, or, if a gain, it was represented by only fractions, or low units, of milligrams; the larger amounts being with *Leguminosæ*, in free air, under a glazed case. After twenty years of varied and laborious investigation, M. Boussingault concluded that plants have not the power of assimilating the free nitrogen of the atmosphere.

Experiments on the subject were commenced at Rothamsted in 1857, they were continued for several years, and the late Dr. Pugh took a prominent part in the inquiry.

The soils used were ignited, washed, and re-ignited pumice or soil. The specially-made pots were ignited before use, and cooled over sulphuric acid under cover. Each pot, with its plants, was enclosed under a glass shade, which rested in the groove of a specially-made hard-baked glazed stoneware lute-vessel, mercury being the luting material. Under the shade, through the mercury, passed one tube for the admission of air, another for its exit, and another for the supply of water or solutions to the soil; and there was an outlet at the bottom of the lute-vessel for the escape of the condensed water into a bottle affixed for that purpose, from which it could be removed and returned to the soil at pleasure.

A stream of water being allowed to flow from a tank into a large stoneware Woulff's bottle, of more than 20 gallons capacity, air passed from it by a tube through two small glass Woulff's bottles containing sulphuric acid, then through a long tube filled with fragments of pumice saturated with sulphuric acid, and lastly through a Woulff's bottle containing a saturated solution of ignited carbonate of soda; and, after being so washed, the air

entered the glass shade, from which it passed, by the exit tube, through an eight-bulbed apparatus containing sulphuric acid, by which communication with the unwashed external air was prevented. Carbonic acid was supplied as required by adding a measured quantity of hydrochloric acid to a bottle containing fragments of marble, the evolved gas passing through one of the bottles of sulphuric acid, through the long tube, and through the carbonate of soda solution, before entering the shade.

In 1857 twelve sets of such apparatus were employed; in 1858 a larger number, some with larger lute-vessels and shades; in 1859 six, and in 1860 also six. Each year the whole were arranged side by side, on stands of brickwork; in the open air. The numerical results obtained in the experiments of 1857 and 1858 are summarised in Table II. (p. 668).

The upper part of this Table shows the results obtained in 1857 and 1858, in the experiments in which no combined nitrogen was supplied beyond that contained in the seed sown. The growth was extremely restricted under these conditions, and the figures in the table show that, neither with the *Gramineæ*, the *Leguminosæ*, nor the *Polygonaceæ* (buckwheat), was there in any case a gain of three milligrams of nitrogen. In most cases there was much less gain than this, or a slight loss. There was, in fact, nothing in the results to lead to the conclusion that either of these different descriptions of plant had assimilated free nitrogen.

The lower part of the Table shows the results obtained in the experiments in which the plants were supplied with known quantities of combined nitrogen, in the form of a solution of ammonium-sulphate, applied to the soil. The effect of this direct supply of combined nitrogen was to increase the growth in a very marked degree, especially in the case of the *Gramineæ*. The figures in the table show that the actual gains or losses of nitrogen ranged a little higher in these experiments, in which larger quantities were involved; but they are always represented by units of milligrams only, and the losses are higher than the gains. Further, the gains, such as they are, are all in the experiments with the *Gramineæ*, whilst there is in each case a loss with the *Leguminosæ*, and with the buckwheat. The losses, if beyond the limits that might be expected from experimental error, are doubtless due to decay of organic matter, fallen leaves, &c.

It should be stated that the growth was far more healthy with the *Gramineæ* than with the *Leguminosæ*, which are, even in the open field, very susceptible to vicissitudes of heat and moisture, and were found to be extremely so under the conditions of enclosure under glass shades. It might be objected, therefore, that the negative results with the *Leguminosæ* are not so conclusive

TABLE II.—*Summary of the Results of Experiments made at Rothamsted, in 1857 and 1858, to determine whether Plants assimilate free Nitrogen.*

			Nitrogen, gram.		
			In Seed, and Manure, if any.	In Plants, Pot, and Soil.	Gain or Loss.
<i>With no combined Nitrogen supplied beyond that in the Seed sown.</i>					
<i>Gramineæ</i>	1857	Wheat . .	gram. 0·0080	gram. 0·0072	gram. -0·0008
		Barley . .	0·0056	0·0072	+0·0016
		Barley . .	0·0056	0·0082	+0·0026
	1858	Wheat . .	0·0078	0·0081	+0·0003
		Barley . .	0·0057	0·0058	+0·0001
		Oats . .	0·0063	0·0056	-0·0007
1858 A <sup>1</sup>	Wheat . .	0·0078	0·0078	0·0000	
	Oats . .	0·0064	0·0063	-0·0001	
<i>Leguminosæ</i>	1857	Beans . .	0·0796	0·0791	-0·0005
		Peas . .	0·0188	0·0167	-0·0021
	1858	Beans . .	0·0750	0·0757	+0·0007
Other plants .	1858	Buckwheat	0·0200	0·0182	-0·0018
<i>With combined Nitrogen supplied beyond that in the Seed sown.</i>					
<i>Gramineæ</i>	1857	Wheat . .	0·0329	0·0383	+0·0054
		Wheat . .	0·0329	0·0331	+0·0002
		Barley . .	0·0326	0·0328	+0·0002
		Barley . .	0·0268	0·0337	+0·0069
	1858	Wheat . .	0·0548	0·0536	-0·0012
		Barley . .	0·0496	0·0464	-0·0032
		Oats . .	0·0312	0·0216	-0·0096
	1858 A <sup>1</sup>	Wheat . .	0·0268	0·0274	+0·0006
		Barley . .	0·0257	0·0242	-0·0015
Oats . .		0·0260	0·0198	-0·0062	
<i>Leguminosæ</i>	1858	Peas . .	0·0227	0·0211	-0·0016
		Clover . .	0·0712	0·0665	-0·0047
1858 A <sup>1</sup>	Beans . .	0·0711	0·0655	-0·0056	
Other plants .	1858	Buckwheat	0·0308	0·0292	-0·0016

<sup>1</sup> These experiments were conducted in the apparatus of M. G. Ville.

as those with the *Gramineæ*. Nevertheless, we concluded, and still conclude, from the results of our own experiments, as Boussingault did from his, that neither the *Gramineæ* nor the *Leguminosæ* assimilate the free nitrogen of the air,

That, under the conditions described, the *Leguminosæ*, as well as the *Gramineæ*, can take up and assimilate already combined nitrogen supplied to them is well illustrated in the experiments made in 1860 with *Leguminosæ* alone. The series comprised three experiments with white haricot beans: No. 1 without any other supply of combined nitrogen than that in the seed; No. 2 with a fixed quantity of nitrogen applied as ammonium sulphate, and No. 3 with a fixed quantity supplied as nitrate; also three experiments with white lupins: No. 1, as with the haricots, without artificial supply of combined nitrogen; No. 2 with supply as ammonium sulphate, and No. 3 as nitrate. Each of these two descriptions of leguminous plant showed considerably increased growth under the influence both of ammonium sulphate and of nitrate—indeed, the growth was much more satisfactory than in the earlier experiments. Still, owing to the atmospheric conditions within the shades, as above referred to, the plants lost both leaves and flowers, and were therefore taken up earlier than they otherwise would have been. The analytical results here again indicated no gain from free nitrogen, either in the experiments without, or in those with, an artificial supply of combined nitrogen—indeed, the losses were greater than the gains.

*Such, then, were the negative results obtained when plants were grown under conditions of sterilisation and of enclosure. There was, under such conditions, no gain from free nitrogen, in the growth of either Gramineæ, Leguminosæ, or other plants.*

#### RECENT EXPERIMENTS, WHICH DO SHOW FIXATION OF FREE NITROGEN.

It was about the year 1876 that M. Berthelot called in question the legitimacy of the conclusion that plants do not assimilate the free nitrogen of the air, when drawn from the results of experiments in which the plants are so enclosed as to exclude the possibility of electrical action; and more recently he has objected to experiments so conducted with sterilised materials, on the ground that, under such conditions, the presence, development, and action of micro-organisms are excluded. So far there is, however, nothing in the recent results, either of M. Berthelot himself or of others, which can be held to invalidate the conclusion which had been drawn from the results of Bous-singault, and from those obtained at Rothamsted, that the higher chlorophyllous plants do not directly assimilate free nitrogen.

Let us now consider what are the results obtained, when the conditions of growth involve neither sterilisation nor enclosure.

*The Vegetation Experiments in 1888.*

As already stated, it was in 1888 that the first of the recent experiments on the subject were made at Rothamsted. This preliminary series comprised experiments with peas, blue lupins, and yellow lupins. The peas were grown—

Pot 1. In washed sand, with the ashes of the plant added; but with no supply of combined nitrogen beyond a small determined amount in the washed sand, and that in the seed sown.

Pot 2. In similarly prepared sand, but microbe-seeded with 25 c.c. of the turbid watery extract from a rich garden soil.

Pot 3. Duplicate of No. 2.

Pot 4. In the rich garden soil itself.

Each of the two descriptions of lupins was grown—

Pot 1. In sand prepared as for the peas, but with lupin-plant-ash instead of pea-plant-ash added.

Pot 2. In similar washed sand, &c., but seeded with 25 c.c. of the turbid watery extract from a sandy soil where lupins had grown luxuriantly.

Pot 3. In the lupin sandy soil itself.

Pot 4. In rich garden soil.

The twelve pots were arranged in a small greenhouse; and distilled water, free from ammonia, was used for watering.

The sand employed was a yellow sand from Flitwick, in Bedfordshire, such as is used by gardeners in the neighbourhood for potting. The stones and coarser portions were removed by sifting, the remainder was several times washed, first with well-water, and afterwards with distilled; then dried in a water-bath, and finally mixed with the plant-ash. It still contained 0.00266 per cent. of nitrogen.

The sandy soil from which the watery extract was made for microbe-seeding the pots where lupins were to grow, and which was used as the soil in experiment No. 3 with lupins, was obtained from land which had been reclaimed from a common in Suffolk, on which no corn crop would grow, but on which, when subsequently sown with blue lupins, they grew as high as the hurdles. Excepting that visible organic matter was removed by sifting and picking, it was used as received, in which state it contained 0.0859 per cent. of nitrogen.

The garden soil contained 10.12 per cent. of moisture and 0.3919 per cent. of nitrogen, corresponding to 0.4360 per cent. on the soil dried at 100° C.

The pots used were made of glazed earthenware. They had a hole half an inch in diameter at the bottom for drainage; and another at the side, near the bottom, for aëration, into which a glass tube bent upwards, and lightly closed with cotton-wool to exclude insects, was fixed. The pots rested on slips of thick sheet glass, placed in basins of the same glazed earthenware as the pots.

The plant-ashes used as mineral nutriment were prepared by suspension in distilled water, adding sulphuric acid to the point of neutralisation, evaporating to dryness, and gently re-igniting.

The drain hole at the bottom of each pot was loosely covered with a piece of thick glass, and 1 lb. of broken, washed, and dried flint was then put in. The pots held from 7 to 9 lb. of the yellow sand, from 6 to 7 lb. of the lupin sand, and about  $4\frac{1}{2}$  lb. of the garden soil.

The soil-extracts supposed to supply the organisms were made by shaking, in a stoppered bottle, one part of the garden soil or lupin sand, with five parts of distilled water, and, after subsidence, pouring off the turbid liquid, which was then passed through platinum gauze to separate any floating matter. Determinations of nitric nitrogen by Schlœsing's method, and of total nitrogen by copper oxide, showed that the 25 c.c. of the garden-soil extract used for microbe-seeding contained little more than three-quarters of a milligram, and the 25 c.c. of the lupin-sand extract little more than a quarter of a milligram, of nitrogen—quantities which are quite immaterial considered as a supply of combined nitrogen.

The seeds were selected for sowing and for analysis by weighing three or four lots of a hundred each to ascertain the average weight per seed, and then a number of single seeds weighing within five milligrams of the mean weight were taken.

It was intended to commence the experiments early in the summer; but owing to the pressure of other work the necessary preparations were not completed until early in August. All the seeds were sown on August 6, three accurately weighed seeds being put into each pot.

From the first the peas germinated and grew well in each of the four pots; but in each of the four of blue lupins, and in each of the four of yellow lupins, one or more seeds failed, and had to be replaced; and in some cases these also failed. It is admittedly very difficult to secure healthy growth with lupins in pots. One essential condition seems to be that the soil must be kept open and porous; and it is also important that the mineral matter added to the soil should be quite neutral.

In the experiments of 1888, the growth was not satisfactory with either blue or yellow lupins; but, as will be seen farther on, it was so with yellow lupins in 1889. It would therefore be a waste of time and space to go into the details, either of the above-ground growth, the root-development, or the analyses of the lupins of 1888; and attention will be confined here to the results obtained with peas in 1888, which, it will be seen, afford very important indications.

As already said, the peas in each of the four pots germinated and grew well. Those in the garden-soil were throughout the most luxuriant. Pots 2 and 3 were each seeded with 25 c.c. of the garden-soil-extract on August 13—that is, just a week after the sowing of the seed.

For some time the plants in pot 1, in the sand without soil-extract, showed more growth, and better colour, than those in either pot 2 or pot 3 with the soil-extract seeding. It was, in fact, not until four or five weeks after the seeding with the soil-extract that the plants in pots 2 and 3 began to show a darker green colour than those in pot 1 without soil-extract. The indication was, however, then so striking that, on September 25, it was decided to count the leaves, and to estimate, approximately, the relative area of leaf-surface of the plants in the different pots. For this purpose the leaves were classified into those which were bright green, those which were changing colour, and those which were withered. It will suffice to show the number, and the estimated relative area, of the total leaves in each case, on September 25, when the first counting and estimates were made, on October 17, on November 14, and on December 14, when the plants were cut. The following table summarises the results.

TABLE III.—PEAS, 1888. *Total number of Leaves, and Estimated relative Leaf Surface, those of the Plants in Pot 1 (without Soil-extract Seeding), on September 25, being taken as 100.*

	Number of Leaves				Estimated relative Leaf Surface			
	Pot 1	Pot 2	Pot 3	Pot 4	Pot 1	Pot 2	Pot 3	Pot 4
September 25 . . . .	144	140	120	164	100	67	58	128
October 17 . . . . .	188	200	184	216	143	172	158	242
November 14 . . . . .	244	300	244	280	170	249	245	328
December 14 . . . . .	382	540	390	434	267	481	434	463

Thus, on September 25, after the plants in pots 2 and 3, with the soil-extract seeding, had begun to show a darker green



colour, they nevertheless showed both a less number of leaves, and considerably less leaf-surface, than the plants in pot 1 without the soil-extract. A possible explanation of the fact that the plants with the soil-extract seeding remained so long in a comparatively backward condition may be that, in the early stages of the development of the nodules and their contents, they rely largely for their nitrogenous nutriment on the compounds of nitrogen already within the plant, and so the development of the higher plant itself is retarded. The figures show, however, that from this date, the plants in pots 2 and 3, with the soil-extract, gradually gained upon those in pot 1 without it, both in number of leaves and in leaf-surface; until, when the plants were taken up on December 14, those in pots 2 and 3 showed 540 and 390 leaves, against only 382 on those in pot 1; and 481 and 434 of leaf-surface, against only 267 in pot 1. There is, therefore, clear evidence of increased growth under the influence of the soil-extract seeding.

In all the pots the upper portions of the plants obviously developed at the expense of the lower, the leaves of which gradually lost colour and withered, whilst the stems and leaves of the upper portion increased in growth; those in pots 2, 3, and 4, continuing to vegetate and to maintain a bright green colour to the last, whilst those in pot 1 showed more exhaustion, and maintained much less colour. Probably owing to the lateness of the season, there was no indication of flowering in any of the pots.

The four pots of plants were photographed on September 1, September 22, October 6, and lastly on November 3, about five weeks before the taking up of the plants.

As the roots had to be preserved without any loss for analysis, the examination of them had to be very carefully conducted, and was necessarily more restricted than if examination had been the only object. After the above-ground growth had been cut off, the pots, with their moist soil and roots, were kept in a warm dry place until the examination commenced. The block of soil was carefully turned out on to glazed cartridge-paper, and notes were at once taken as to the distribution of roots so far as it was then apparent. The sand or soil was then removed little by little until the roots were left nearly bare. Further notes were then taken, after which the remaining sand or soil was removed as far as possible by washing in a beaker with a little distilled water. The roots were then mounted upon paper, and so photographed, and finally noted upon.

In order to stimulate and assist the observation of others, it will be well to give some description of the development of the roots, and of the nodules on them, of the various experimental

plants, for, as will be seen, the differences in these respects are very great with different descriptions of plant, and under the different conditions of growth.

The roots of the peas in pot 1, with the washed and dried, but not sterilised, yellow sand, showed a densely matted mass of fibre, by far the greater portion of which was accumulated within the top four inches: and, notwithstanding there was no soil-extract seeding, there were many nodules on the roots, but fewer, and generally much smaller, than on those grown with the soil-extract seeding. They were also less characteristically accumulated near the surface, and more distributed along the root fibres. There were, however, some agglomerations of nodules. Comparing this result with that obtained in 1889, with a purer and sterilised sand, in which case there were no nodules, there can be little doubt that the development of nodules, and the fairly luxuriant growth in this pot without soil-extract seeding, are to be attributed to the impurity and non-sterilisation of the sand.

The roots in pot 2, with soil-extract seeding, also showed a dense mass of fibre, which, however, extended from the top to the bottom of the sand, penetrated the layer of flints, and distributed over the bottom of the pot. The roots were, in fact, much more generally distributed and less accumulated within the surface layers than in pot 1. The most developed root had three large agglomerated nodules, each with some scores of protuberances, somewhat as on a raspberry or mulberry. The other plants also showed similar nodules, but of a smaller size. There were also a number of small clusters distributed over the rootlets, but very few single nodules, differing in this respect from the development observed in pot 1.

In pot 3, also with soil-extract seeding, each of the three plants developed a mass of root-fibre extending throughout the sand, but less near the bottom. There were large agglomerations of nodules on the roots of each plant. There were, besides, many small clusters, and here and there single nodules. By far the most of the nodules were within the top three inches of the sand, but one considerable bunch was found as low as four inches from the surface. As in the other cases, the nodules were grey, and much lighter in colour than the roots on which they grew.

Each of the three plants in pot 4, with the garden soil, had a stouter main root than any of those in the other pots. From the side branches there proceeded a large amount of fine root-fibres which extended throughout the whole soil, those from the different plants being much interwoven. The roots extended round the sides and along the bottom of the pot, much more



It is seen that there is more dry substance in the above-ground growth, but less remaining in the roots, in pots 2 and 3 with the soil-extract, than in pot 1 without it. In the whole plant there is about 10 grams of dry substance in pot 1 without soil-extract, against about  $11\frac{3}{4}$  grams in pot 2, and more than 11 grams in pot 3, each with soil-extract.

The point of chief interest is, however, that there was in one case more than twice, and in the other nearly twice, as much nitrogen in the above-ground growth in pots 2 and 3 with the soil-extract seeding, as in pot 1 without it. But there was much less difference in the amounts remaining in the roots under the different conditions. Of nitrogen in the total vegetable matter grown, there is, in pot 2 nearly twice, and in pot 3 more than  $1\frac{1}{2}$  time, as much as in pot 1 without the soil-extract. In pot 4 with garden soil, and with therefore full supply of already combined nitrogen, there was more dry substance produced, and more nitrogen assimilated, than under the influence of the soil-extract seeding.

The significance of the results relating to the nitrogen is, however, more clearly seen in the next Table (V.), which shows the amounts in the soil at the commencement and at the conclusion of the experiment, and the gain or loss; the amounts in the seed, in the total products of growth, and the gain; the total nitrogen in the soil and seed at the commencement, in the soil and produce at the conclusion, and the gain. The Table also shows, in the last column but one, the nitrogen in the total products, reckoning the total initial nitrogen = 1; and in the last column, the amount in the plants, reckoning that in the seed = 1.

TABLE V.—PEAS, 1888.

	Nitrogen										
	In sand or soil			In seeds and produce			Total			In total products, total initial = 1	In plants, nitrogen in seed = 1
	At commencement	At conclusion	Gain (+) or loss (-)	In seeds sown	In total plants	Gain	At commencement	At conclusion	Gain		
Pot 1	grams. 0.0999	grams. 0.1096	gram. +0.0097	gram. 0.0293	gram. 0.2822	gram. 0.2529	grams. 0.1292	grams. 0.3918	gram. 0.2626	3.03	0.63
Pot 2	0.0999	0.0974	-0.0025	0.0298	0.5361	0.5063	0.1297	0.6335	0.5038	4.88	17.99
Pot 3	0.0999	0.0848	-0.0151	0.0291	0.1357	0.4066	0.1290	0.5205	0.3915	4.04	14.97
Pot 4	7.9989	7.9989	—	0.0301	0.6600	0.6299	8.0290	8.6589	0.6299	1.08	21.93

The first point to notice is that there is very little difference in the amount of nitrogen in the sand or soil at the commencement and at the conclusion of the experiments. There would,

doubtless, be some fine root-fibre not removed at the conclusion, so that where there is loss it is to be supposed that some of the original nitrogen of the sand has contributed to the growth. In the case of the garden-soil, with its high percentage of nitrogen, it is, of course, not impossible that there may have been some loss by the evolution of free nitrogen.

That there is at any rate no material gain of nitrogen in the sand or soil would seem to be confirmatory of the conclusion indicated by other evidence, that the fixation is not effected by the organisms within the soil, independently of the symbiotic growth of the nodules and their contents, and of the higher plant to which they are attached, and to whose nitrogenous supply they seem to contribute. Indeed, if the fixation had taken place under the influence of microbes within the soil, independently of connection with the higher plant, we should expect some accumulation within it, or we should have to conclude that the plant had availed itself of exactly the whole of the nitrogen so brought into combination—a supposition for which there would seem no reasonable justification.

Turning to the middle division of the Table, which shows the nitrogen in the seed sown, in the total vegetable matter grown, and the gain, and disregarding the changes in the soils, which it has been seen may well be done, it will be observed that, in the case of pots 1, 2, and 3, with sand, the gain in the plants is so large as to be very far beyond the limit of any possible experimental error. This certainly cannot be said of some of the experiments which have been conducted on other lines in regard to the question of the fixation of free nitrogen.

The gain of nitrogen in these initiative experiments is, however, much less than in many of those of Hellriegel and Wilfarth, and also much less than in subsequent experiments at Rothamsted. This is not to be wondered at when the late period of the season, and the consequent character of the growth, are borne in mind.

To refer to the figures, it is seen that, whilst the nitrogen supplied in the seed was only 0.03 gram or less, that in the products of growth was 0.2822 gram in pot 1, 0.5361 in pot 2, 0.4357 in pot 3, and 0.6600 in pot 4; and the gains were more than  $\frac{1}{4}$  of a gram in pot 1, more than  $\frac{1}{2}$  a gram in pot 2, about  $\frac{2}{3}$ ths of a gram in pot 3, and more than  $\frac{3}{4}$ ths of a gram in pot 4.

The third division of the Table shows the total nitrogen at the commencement (in soil and seed together), at the conclusion (in soil and total vegetable matter grown), and the gains.

But the significance of the results is more clearly seen in

the last two columns. The first of these shows the relation of the amount of nitrogen in the total products (soil and plants together) to the total initial nitrogen (soil and seed together), taken as 1. Even in pot 1, with the impure and not sterilised sand, but without soil-extract, there was, so reckoned, more than three times as much nitrogen in the products as in the soil and seed; in pot 2, with soil-extract seeding, there was nearly five times as much; and in pot 3, also with soil-extract, there was more than four times as much. In the case of pot 4, however, with garden soil, owing to the large amount of initial nitrogen in the soil, the gain, though actually large, appears when so reckoned but small.

It is in the last column of the Table, in which, disregarding the nitrogen in the soils, which was so nearly the same at the beginning and at the end, and reckoning the relation of the nitrogen in the total products of growth to that in the seed taken as 1, that the large amount of fixation is clearly brought to view. So reckoned, the nitrogen in the substance grown to that in the seed sown was: in pot 1,  $9\frac{1}{2}$ -fold; in pot 2, nearly 18-fold; in pot 3 nearly 15-fold; and in pot 4, nearly 22-fold.

*Here, then, under non-sterilised conditions—in fact, with suitable microbe-infection of the soil—there was very considerable fixation of free nitrogen.*

#### *The Vegetation Experiments in 1889, 1890, and 1891.*

Since 1888 more extensive series of experiments have been made, on substantially the same lines as those already described. In 1889 peas, vetches, blue lupins, yellow lupins, red clover, and lucerne were sown; and in 1890 beans, white clover, and sainfoin. Excluding the blue lupins, which failed, it will be seen that the series included experiments with four annuals, namely, peas, vetches, beans, and yellow lupins; also with four plants of longer life, namely, white clover, red clover, sainfoin, and lucerne. And, as will be seen further on, experiments with the same four annuals, and the same four plants of longer life, were commenced in 1890, of which some are still in progress, on somewhat different lines from those above referred to, with a view to the investigation of some points of importance, which the necessary conditions of growth and subsequent treatment of the plants in the glass-house did not admit of.

Referring to the experiments in the glass-house, it may be stated that for the lupins, the sainfoin, and the lucerne, specially-made pots of glazed earthenware were employed. They were

about six inches in diameter, and fifteen inches deep inside ; that is, about twice as deep as those used in 1888, and again in 1889 and 1890, for the peas, vetches, beans, white clover, and red clover. These larger pots had holes at the bottom for drainage, and slits at the sides, near the bottom, for aëration. Each of the pots, large or small, stood in a specially-made pan of the same material. A quantity of broken, washed, and this time ignited flint was put into the bottom of each pot. The sand used was a rather coarse white quartz sand, from which the coarser and the finer portions were removed by sifting, and more of the finer by washing and decantation, first with well, and afterwards with distilled, water. In defect of means for igniting so large a quantity of material (several hundred pounds in all), without running the risk of gaining more impurity than was expelled, the portion retained for use was kept, in successive lots, in a large water-bath, at nearly 100° C., for several days, and then preserved in well-closed bottles. The results have shown that the sand so prepared was sufficiently, if not absolutely, sterilised.

In all the experiments commenced subsequently to 1888 the sand was mixed with only 0·1 per cent. of the plant ash and 0·1 per cent. of calcium carbonate.

There were four pots of each description of plant, excepting in the case of the white clover, of which there were five. For the peas, vetches, beans, white clover, red clover, sainfoin, and lucerne, No. 1 was with the prepared quartz sand, without soil-extract ; Nos. 2 and 3 were with the quartz sand and garden soil-extract added ; and No. 4 was with the garden soil itself ; the fifth pot of white clover receiving calcium nitrate instead of soil-extract. Of the lupins (both blue and yellow), No. 1 was with the prepared quartz sand, without soil-extract ; Nos. 2 and 3 were with lupin soil-extract added ; and No. 4 was with the lupin sandy soil itself, to which 0·01 per cent. of the plant ash was added.

The soil-extracts were added the day before the sowing of the seed ; 25 c.c. in the case of the plants grown in the smaller, and 50 c.c. in that of those grown in the larger, pots.

The seeds were selected and weighed as in 1888.

The analytical details relating to the experiments commenced in 1889, and subsequently, are not yet completed ; nor have those already available yet been arranged and published, so that numerical results cannot be given here. The following notes on growth and descriptions of the plants and their roots, together with a general statement of the bearing of the analytical data in some cases, will, however, convey a clear idea of the im-

portance and of the significance of the results which have so far been obtained.

The peas were sown on July 10, two seeds being put into each of the four pots; and the plants were taken up on October 23 and 24. Photographs of the four pots of plants were taken on August 3, August 20, September 27, and lastly on October 22; that is, the day before taking up. Unlike the result obtained in pot 1 in 1888 with impure and non-sterilised sand, the plants of 1889, in the purer and sterilised quartz sand, showed extremely limited growth. Before the end of July, those in both pots 2 and 3, with soil-extract seeding, began to show enhanced growth compared with that in pot 1, without the soil-extract; and, eventually, whilst the plants in pot 1 were only  $8\frac{1}{4}$  and  $8\frac{1}{2}$  inches in height, those in pot 2, with soil-extract, were 14 and  $50\frac{1}{2}$  inches; and those in pot 3, also with soil-extract, were  $40\frac{1}{4}$  and  $39\frac{1}{2}$  inches high. In pot 4, with the garden soil, the heights of the plants were  $38\frac{1}{2}$  and  $41\frac{1}{2}$  inches, or only about the same as in pot 3 with the soil-extract only. But the plants in pot 4 were more vigorous, and whilst they flowered and seeded, neither of those in either pot 2 or pot 3 did so, but continued to vegetate, the upper parts apparently at the expense of the lower.

Then as to the root development:—In pot 1, without soil-extract, and with extremely limited above-ground growth, it was altogether much less than in either pot 2 or pot 3 with soil-extract, or than in pot 4 with garden soil. Again, in pot 1, without soil-extract seeding, the main roots descended some distance before they threw out any considerable amount of root-branches and root-fibre; whereas, in pots 2 and 3, with soil-extract, there was characteristically much more fibre distributed, both in the upper layers and throughout the pot.

It is specially to be noted that, whereas in pot 1 in 1888, with impure and non-sterilised sand, there was some development of nodules, now, in the pure and sterilised sand, not a nodule was observable.

In pot 2, with soil-extract seeding, one plant was very much larger than the other, and developed much more root. The smaller plant had, however, several nodules on the main root, near the surface of the soil, and a good many small ones distributed along the fibres. Most of the nodules were more or less shrivelled. The larger plant had a large cluster of nodules on the main root, very near the surface; and a very large number of single nodules, mostly small, was distributed on the root-fibres, quite to the bottom of the pot. Upon the whole those on the larger plant were less shrivelled.



In pot 3, also with soil-extract, and with two tall plants, the main roots extended to, and along, the bottom of the pot; throwing off many side branches, with a very large quantity of fine fibrous root. The greatest distribution was, however, in the upper few inches of the soil. There were two clusters of nodules on one of the plants, and three on the other, besides smaller bunches. A large number of mostly single small nodules was also distributed along the roots. On one of the plants the largest cluster was on the main root, and on the other the clusters were on the side branches.

In pot 4, with the garden soil, and not higher plants, but more vigorous and more matured growth than with soil-extract only, there was a dense mass of root-fibre throughout the first six inches of depth. There were numerous nodules, the majority single and within the upper two or three inches of soil. There were also a few small bunches.

Thus, then, the limited growth in pot 1, without soil-extract, was coincident with the entire absence of nodule-formation; and the increased growth in pots 2 and 3, with soil-extract, was coincident with a very great development of nodules. In pot 4, with garden soil, itself supplying abundance of nitrogen, there was also a considerable development of nodules, but distinctly less than in either pot 2 or pot 3, with soil-extract only.

*Lastly, without soil-extract, and without nodules, there was no gain of nitrogen; but, with soil-extract, and with nodule-formation, there was much gain of nitrogen, there being many times as much in the products of growth as in the seed sown.*

The vetches were sown on July 10, two seeds being put into each pot; and the plants were taken up on October 26. The four pots of plants were photographed on August 3, August 20, September 27, and lastly on October 25, the day before being taken up.

As with the peas, the plants in pots 2 and 3 with soil-extract had, before the end of July, shown more growth than those in pot 1 without it. Again, as with the peas, the vetches in the pure and sterilised sand showed extremely limited growth. On the other hand, those in pots 2 and 3, with the soil-extract, grew to a great height—indeed, higher than those in pot 4 with the garden soil. The heights of the plants were: in pot 1, without soil-extract,  $11\frac{1}{4}$  and  $10\frac{1}{2}$  inches; in pot 2, with soil-extract,  $52\frac{1}{2}$  and 67 inches; in pot 3, also with soil-extract,  $62\frac{1}{2}$  and 51 inches; but in pot 4, with garden soil, only 53 and 36 inches. But, as in the case of the peas, whilst the plants in pot 4, with

the garden soil, flowered and seeded, those in pots 2 and 3, with the soil-extract only, did not, but continued to vegetate, extending upwards, the higher and newer portions apparently at the expense of the lower and older parts of the plant.

In pot 1, without soil-extract, and with very limited above-ground growth, there was much less development of root than in either pot 2 or pot 3 with soil-extract, or than in pot 4 with the garden soil. The main roots descended to the bottom of the pot, and threw out a number of side branches, but there was a marked deficiency of root-fibre; and not a single nodule was formed.

In pot 2, with soil-extract seeding, and very extended above-ground growth, there was a dense mass of root and root-fibre, which distributed throughout the pot, though the greatest accumulation was within the first three inches of depth. There were numerous nodules, but considerably less in quantity than on the corresponding pea roots. They were mostly single, and the greater number were found in the lower layers, which is also contrary to the result with the peas. They were, moreover, generally exceedingly small.

In pot 3, also with soil-extract, and with very extended above-ground growth, there was also an immense development of root and root-fibre, through the whole area of the sand; the greatest accumulation being in the upper and lower portions of the pot, with less in the middle. There were again many nodules, but very small, and probably fewer than on the roots in pot 2. All the nodules were single, and fairly distributed over the whole root area.

In pot 4, with garden soil, and as with the peas, less extended but more vigorous and more matured growth than in sand with soil-extract only, there was a moderate amount of root and of root-fibre, chiefly within the upper six inches of depth; but there was altogether very much less of root development than in either pot 2 or pot 3, with the sand and soil-extract. There were many nodules, but all single and very small; and they appeared to be flattened, as if exhausted of their contents.

Here, then, with the vetches, as with the peas, the very restricted above-ground growth in pot 1, without soil-extract seeding, was associated with very limited root development, and with the entire absence of nodule-formation. On the other hand, the greatly extended vegetative growth in pots 2 and 3, with soil-extract, was associated with an immense development of root and root-fibre, and with the formation of numerous nodules. Again, in the garden soil, with its liberal supply of combined nitrogen, there was much less development of roots,

and less also of nodules, than in the pots with soil-extract only.

*Lastly, without soil-extract seeding, and with no nodules, there was no gain of nitrogen; whilst, with soil-extract, and with numerous nodules, there was considerable gain of nitrogen; there being, with much less nitrogen in the seed, and about the same amount in the products, as in the corresponding experiments with peas, very many times as much nitrogen in the vegetable matter produced as in the seed sown.*

As already said, the experiments with blue lupins failed. Those with yellow lupins, however, gave very striking results.

As in the case of the other plants grown in 1889, the yellow lupin seeds were sown on July 10, three being put into each pot. There were some re-sowings, some seeds taken out, and eventually two plants were left in each pot. By the end of July the plants in pots 2 and 3, with the lupin soil-extract seeding, already showed more growth than those in pot 1 without it. Photographs of the plants were taken on August 3, August 20, September 27, October 28, and November 29; and the plants were taken up on December 7.

The plants in pot 1, without soil-extract seeding, scarcely appeared above the rim of the pot, one being only about  $1\frac{1}{2}$ , and the other only  $2\frac{3}{4}$  inches high. In pot 2, with lupin soil-extract seeding, one plant was about 24, and the other  $18\frac{1}{2}$  inches high; both spreading much beyond the width of the pot. In pot 3, also with lupin soil-extract seeding, one plant was more than 24, but the other little more than 8 inches high. In fact, in both the pots, with quartz sand, ash, &c., and soil-extract seeding only, the plants developed considerably more than those in pot 4, with the lupin-soil itself; one of these being only about 16 inches, and the other about  $18\frac{1}{2}$  inches high, and both less branching than those in pots 2 and 3.

Unlike the peas and vetches, the yellow lupins, with soil-extract seeding only, flowered and podded freely. Thus, in pot 2, one plant flowered only, but the other had nine small pods; and in pot 3, one had four large and three small pods, and the other a flower forming. There were also in pot 4, with lupin-soil, on one plant five pods, and on the other, six. The general result was that, in the quartz sand with lupin soil-extract seeding, the plants not only produced a great deal more vegetable matter than those in the lupin sand itself, but they as freely flowered and seeded.

In pot 1, without soil-extract, and very restricted above-ground growth, there was coincidentally very little root develop-

ment; the main roots descended far down the deep pot almost without branching, but, at the bottom, a number of branches and a mass of root-fibre were produced; the root-fibres were fleshy and succulent. No root-swellings or nodules were found.

In pot 2, with the lupin soil-extract seeding, and luxuriant and maturing above-ground growth, there was, on the other hand, a very great development of root. Branches were thrown out throughout the whole length; and at their ends masses of fleshy fibres were formed, which were thickly coated with root-hairs. On the main root of one plant, about three inches down, there was a large swelling or nodule the size of a field bean; four inches lower there were three smaller ones on a side branch; ten inches down, there were three as large as peas; and lower still, there was another small swelling, more like the nodules found on other plants. The other plant had less root growth. One and a half inch down there was a swelling the size of a small pea; and between four and five inches lower there were three swellings, one as large as a bean, and the others about the size of a vetch seed. These swellings on the lupin roots, which were all on the main roots or thicker branches, were very different in appearance from the nodules on the pea and vetch roots. They were, as described, swellings, encasing the root where they grew.

In pot 3, also with lupin soil-extract seeding, the plant which showed both great above-ground luxuriance and great seed-forming tendency, developed an immense amount of branching root, with a great deal of root-fibre, which extended throughout the sand, but to a greater degree in the lower than in the upper half of the pot. The main root was woody near the top. The lower root-fibres were fleshy and thickly coated with root-hairs. There were several swellings or nodules on the main root below 5 inches; and lower down on a root branch there were several swellings; there being in all twelve on this plant. The roots of the less luxuriant and less matured plant were smaller and more meagrely developed; about 10 inches down there were two bunches of small nodules, and three single nodules; and a little lower on a side branch another small nodule.

With regard to the great development of the root-hairs on the fine fibrils of the roots of both pots 2 and 3, with quartz sand and soil-extract seeding, it may be supposed that this was an effort to acquire mineral nutriment, in quantity commensurate with the large amount of nitrogen fixed, and of nitrogenous nutriment so rendered available to the plant.

In pot 4, with the lupin-soil itself, and less luxuriant above-ground growth, the distribution of root was also very different

from that in pots 2 and 3 with the soil-extract only. The main root, at a depth of 2 inches, threw out many thread-like branches, at the end of each of which there was a bundle of fine fibre. The lower fibres became thicker, and were white and fleshy; but they were without the marked development of root-hairs observed in such abundance in pots 2 and 3. Most of the root was within 6 inches of the surface, and there seemed to be none below 14 inches. One or two inches from the surface there were swellings on the main roots, which were less raised, but more spreading, than those on the roots in pots 2 and 3. There were also, on one side branch, six very small nodules.

To sum up in regard to the yellow lupins: in the sterilised quartz sand, without soil-extract seeding, the growth was extremely limited both above and under ground. Under the influence of the lupin soil-extract seeding, the above-ground growth was not only very luxuriant, but the plants developed considerable maturing tendency, flowering and seeding freely. The development of the roots generally, and that of swellings or nodules on them, were also very marked. In pot 4, with the lupin-sand itself, which would supply a not immaterial amount of combined nitrogen, although the growth was fairly normal, it was, both above ground and within the soil, much less than in the pots with soil-extract only; and the development of nodules was also less. It is probable that the less growth in the lupin-sand itself, than in the quartz sand with soil-extract, was largely due to the much less porosity of the lupin soil, especially when watered.

*Again, as with the peas and the vetches, so with the lupins, without soil-extract seeding, there was very limited growth, no formation of nodules, and no gain of nitrogen; but, with soil-extract seeding, there was luxuriant growth, abundant nodule-formation, and, coincidentally, great gain of nitrogen. There was, in fact, very many times as much nitrogen in the products of growth as in the seed sown.*

The foregoing results with peas, vetches, and yellow lupins are very definite and very striking. They are abundantly illustrative of the fact that under the influence of suitable microbe-seeding of the soil, there is nodule-formation on the roots, and, coincidentally, increased growth, and gain of nitrogen beyond that supplied in the soil and in the seed as combined nitrogen, presumably due to the fixation, in some way, of free nitrogen.<sup>1</sup>

---

<sup>1</sup> MM. Schloesing *filis* and Laurent have shown, by growing *Leguminosae* in closed vessels, and by the analysis of the air before and after growth, that free nitrogen disappeared, in quantity closely corresponding to that gained in growth; thus establishing the fact that the source of the gain was free nitrogen (*Compt. Rend.* cxi. 750).

As already said, experiments were also made with a fourth annual, namely beans; and with four plants of longer life—white clover, red clover, sainfoin, and lucerne. With some of these the growth was not so satisfactory as with the peas, the vetches, and the yellow lupins; partly owing to failure to ensure suitable infection of the roots. With both clovers there will doubtless be considerable gain, especially with the white clover, which, however, is still growing.

In reference to the failure of growth in the cases where it was apparently due to failure to obtain suitable microbe infection, it has already been said that Hellriegel at first found great difficulty in ensuring a good result with lupins, serradella, and some other plants, among which was red clover; and the failure to obtain good results at Rothamsted with both blue and yellow lupins in 1888, and with blue lupins in 1889, was doubtless mainly due to the same cause.

As bearing upon this curious and interesting point, it will be well briefly to refer here to the experiments and results of Professor Nobbe on this subject.<sup>1</sup> He undertook an investigation, in the first place to determine whether leguminous trees, as well as our agricultural leguminous plants, were susceptible to microbe infection and nodule-formation; and secondly to ascertain whether there is one nodule-forming bacterium, or whether many bacteria have the property—each description of plant, or perhaps each group, having its special bacterium.

The plants he experimented upon were peas, yellow lupins, and beans; also as trees, *Robinia pseudacacia* (locust tree), *Cytisus laburnum* (laburnum), and *Gleditschia triacantha* (honey locust). To each of these he applied microbe-seeding from various sources; in some cases, only soil-extracts, and in others pure cultivations, either from soil-extracts, or from the root-nodules of different plants. When soil-extracts only were used the results were somewhat irregular. For example, with peas a better result was obtained by the use of *Gleditschia*, *Robinia*, or *Cytisus*, soil-extract, than of pea soil-extract. With *Robinia*, on the other hand, the best result was obtained with *Robinia* soil-extract. But when pure cultivations were employed, the general result was that more effect was produced on any particular description of plant by the bacteria obtained from the same description than by those derived from other descriptions. Thus, with peas there was more produce, and more nitrogen assimilated, by the application of pure cultivations of pea nodule and pea soil bacteria, than by that of lupin nodule, lupin soil,

<sup>1</sup> *Versuche über die Stickstoff-Assimilation der Leguminosen.* F. Nobbe, E. Schmid, L. Hiltner, E. Hotter. Versuchs-Stationen, xxxix. 327.

*Robinia* nodule, or *Robinia* soil bacteria. On the other hand, the *Robinia* nodule bacteria, which showed no action with peas, had marked effects on *Robinia*. Still, this did not apply in all cases, there being sometimes more produce, and more nitrogen gained, under the influence of the microbe infection from another than from the same description of plant. In some cases infection had more effect than manuring with ammonium-salts or nitrate. Nobbe concludes, however, that the results can leave no doubt that the pea and the *Robinia* bacteria have different physiological actions, which indicate, if not different species or varieties, at any rate different race or nutrition modifications.

Beyerinck also concludes that the various papilionaceous bacteria differ more than he had formerly supposed. Thus, he found that *Vicia Faba*, infected with the bacteria from *Ornithopus*, produced no nodules; and he considers that the difference between the bacteria of beans and serradella accounts for the fact that serradella had no nodules when growing in a garden between beans which had numerous nodules.

Of the three descriptions of leguminous trees upon which Nobbe experimented, the *Robinia* and the *Cytisus*, which are both of the papilionaceous sub-division of the leguminous family, were susceptible to microbe infection, and nodule-formation on their roots, and showed coincidently gain of nitrogen; but the *Gleditschia*, which is not papilionaceous, but of the sub-order *Caesalpinieæ*, was quite indifferent to such infection, although both soil-extracts and pure cultivations from various sources were tried. On the other hand, it was found that the application of calcium nitrate and ammonium sulphate gave considerably increased growth. Nobbe observes that the roots of *Gleditschia* have a very thick covering which it would be at any rate difficult for the bacteria to penetrate; but whether the members of this group generally behave differently from the *Papilionaceæ* in this respect remains for future investigation to determine. It is at any rate of interest to note that the only leguminous plant outside the papilionaceous sub-order which has yet been experimented upon has not been found susceptible to infection, or to have nodules on its roots.

#### DIFFERENCE IN THE EXTERNAL CHARACTER OF LEGUMINOUS ROOT-NODULES.

The conclusion drawn from the evidence which has been cited—that there are various nodule-forming bacteria—is at any rate consistent with the descriptions which have been given

of the plants grown at Rothamsted in 1889, which have shown that the external appearance, and the distribution, of the root-nodules were very different in the case of the peas, the vetches, and the lupins. In that of the peas there were many of what may be called agglomerations of nodules, and comparatively few single ones distributed on the root-fibres. On the roots of the vetches there were comparatively few agglomerations or bunches, and more single nodules, pretty widely distributed along the root-fibres. The lupin roots, on the other hand, showed tubercular developments very different from those on either the pea or the vetch roots. Indeed, at the period of examination—that is, when the plants were nearly ripe—two apparently distinct kinds were observed, one of which, the most prevalent, has been spoken of as “swellings,” and the other as “nodules.” The “swellings” were chiefly on the main roots or the thicker branches; where they grew they encased the root entirely, and they had a shining and presumably impervious skin. The “nodules,” on the other hand, were chiefly single, small, and distributed on the root-fibres.

Assuming that the so-called “swellings” (with their contents) on the roots of the lupins were the bodies which had exercised the functions of the “nodules” found on the roots of the other plants, it is to be concluded that, after the very luxuriant growth, and the flowering and seeding, their function was so far at an end, and they had become suberised. The other bodies on the lupin roots, distinguished in the detailed description as “nodules,” indicated too meagre development to have had much share in the great amount of assimilation that had been accomplished. On the other hand, the “swellings,” which, as has been said, were all on the main roots or thicker branches, were certainly very characteristic of the roots of the lupin plants which attained the greatest growth; and, assuming that they, with their contents, were really the effective bodies, it must be supposed that they had been formed where they were found whilst the root was still young, and had grown with its growth. In favour of this supposition is the fact that the increased growth from the soil-extract seeding commenced quite early in the life of the plants.

The nodules on the roots of lucerne growing in the field were observed at different periods of the season in 1887, and again quite recently on plants taken from the field for that purpose. They are quite different in general external character from those on any of the other plants that have been examined at Rothamsted. Instead of being more or less rounded, they have more the appearance of shoots or buds, much longer



than broad, sometimes single, but more often divided or branched, there being generally two or three, and sometimes as many as twenty, or even many more, in a bunch, joined at the base. They have, so far, not been observed on the main root, but only on the root-fibres, and less near the surface than within the range of the subsoil. In some cases such a tuft or bunch will be at the end of a fine fibre, by which it is connected with the main root. As the season advances these bodies become shrivelled, and are in fact empty shells.

Among the *Leguminosæ* growing in the mixed herbage of grass land in 1868 nodules were observed on the root-fibres of *Lathyrus pratensis*, especially near the surface of the soil; on the ultimate root-fibres of *Trifolium pratense*; and on the smaller rootlets of *Trifolium repens*.

In the case of red clover growing in rotation on arable land, an abundance of nodules has been found, both near the surface and at a considerable depth. They are generally more or less globular or oval. Some found on the main roots were more like "swellings" than attached tubercles, not, however, encasing the root, but only on one side. The greater number are, however, small and distributed chiefly on the root-fibres. Again, on the plot of rich garden soil on which red clover has now been grown at Rothamsted for thirty-eight years in succession, very numerous nodules, chiefly globular and small, have been found on the roots—for the most part within the first few inches of soil, but some to the depth of a foot or more, diminishing, however, very much both in number and in size as the clayey subsoil was reached.

Obviously much more evidence than the foregoing few observations can supply is needed in regard to any difference in character, or relative prevalence, at different periods in the life and growth of the plant, and under different conditions of soil, both so far as mechanical state and porosity, and richness or otherwise in available supplies of combined nitrogen are concerned, before any clear conception can be attained of the connection between nodule-formation, luxuriance of growth, and gain of nitrogen. The subject in various aspects is being further investigated at Rothamsted, and some of the results so far obtained will be briefly referred to farther on.

#### HOW IS THE FIXATION OF NITROGEN TO BE EXPLAINED?

Reviewing the whole of the results which have been brought forward, there can be no doubt that the fact of the fixation of free nitrogen in the growth of *Leguminosæ* under the influence

of suitable microbe infection of the soil, and of the resulting nodule-formation on the roots, may be considered as fully established.

Admitting, then, the fact of fixation under the conditions described, the question still remains: How is it to be explained? Unfortunately, there is much yet to learn before a satisfactory answer can be given. Obviously we must know more of the nature and mode of life of the organisms which, in symbiosis with the leguminous plant, bring about the fixation of free nitrogen, before the nature of the action can be understood. As to the mode of life of these bodies, we owe much to the investigations of Marshall Ward, Prazmowski, Beyerinck, and others; but the facts which they have established so far are insufficient to afford an adequate explanation of the phenomena involved.

It is a point of importance that it should be established, as it appears to be, that in the development of the parasite the cortex of the root of the host is penetrated, and so an intimate connection between the two—indeed, a symbiosis—is set up. Then there is abundant evidence that the nodules are very rich in nitrogen. Indeed, in certain stages of their development, their dry substance may contain a much higher percentage of nitrogen than that of any part of the growing plant itself; and, in some cases at any rate, even higher than in that of the highly nitrogenous leguminous seed.

Whence comes this nitrogen? The views of those who have studied the histology and biology of the subject, without reference to quantitative chemical data, do not seem to be very clear or definite on the point. Thus, it has been assumed that the bacteria acquire their nutriment, including their nitrogen, from the protoplasmic cell-contents of the higher plant; and that, on the other hand, the contents of the bacteroid cells are resorbed. In other words, the plant utilises the substance of the bacteroids. It is obvious, however, that, so far as the nitrogen of the bacteria is derived from the plant itself, the latter is not a gainer in a quantitative sense by its resorption.

It has further been assumed that the activity of the process depends on the quantity of the nitrogenous compounds at the disposal of the roots, the tubercles developing unhindered, and becoming large and typical, in a soil rich in nitrogen, but attaining no great size in poorer soils. The source of the nitrogen of the bacteria is here supposed to be combined nitrogen in the soil. The experimental results which have been described clearly show, however, that the nodules may develop very plentifully in a nitrogen-free soil, and that there may, under such

conditions, be great gain of nitrogen if only the soil be suitably infected. Nor would there be any such actual gain of nitrogen in nitrogen-free soils, as there undoubtedly is, if the source of the nitrogen, either of the parasite or of the host, were essentially the supplies of combined nitrogen within the soil.

Further, one assumption is, that the organisms become distributed in the soil both during the life of the host and afterwards, and that the fixation takes place under their agency within the soil itself, rather than in the course of the development of the bacteria in symbiosis with the higher plant. Another assumption is, that the fixation takes place in the soil itself under the influence of microbes existing within it, and that the higher plant assimilates the resulting combined nitrogen. As bearing upon these points, it may be observed that in the experiments with peas in 1888 there was practically no gain of nitrogen within the soil itself, which it may be supposed there would have been if the fixation had taken place within it, and the host had acquired its gain from the compounds there produced. Indeed, the evidence at present at command certainly does not point to the conclusion that the gain of nitrogen by *Leguminosæ* under the influence of microbe infection of the soil, and nodule-formation, is due to fixation by organisms within the soil itself, independently of the symbiosis. It is obvious, too, that, so far as free nitrogen may be fixed by microbes within the soil, independently of connection with a higher plant, the resulting nitrogenous compounds should, directly or indirectly, be available to plants generally, whether leguminous or non-leguminous.

On this point it may be remarked that about thirty years ago Boussingault concluded, from the results of vegetation experiments made in 1858 and 1859 in mixtures of rich soil and sand, that free nitrogen had been fixed within the soil by the agency of mycodermic vegetation, and that the nitrogenous products which remained within it were largely in the form of organic detritus. Subsequently, however, he considered that there was not satisfactory evidence that free nitrogen is fixed within the soil under the influence of the development of lower organisms. It is, nevertheless, of interest to observe that those of his results in 1858 and 1859 which showed any material gain of nitrogen, either in the vegetable matter grown, or in the soil, were obtained with *Leguminosæ*, and that in the case in which there was the greatest gain in the plants themselves, he records that there were numerous tubercles on their roots. In one other case, in which, however, only sand was used as soil, and the gain in the plant was but small, he also observed tubercles on

the roots. In the other cases of gain no mention is made of tubercles, and it may be that the roots were not so examined as to determine whether they existed or not. It is, at any rate, very significant, when viewed in the light of recently acquired knowledge, that in all the cases of gain the plants grown were of the leguminous family, and that in some of them nodules were observed on the roots.

Again, Berthelot's experiments showed fixation of free nitrogen by the agency of microbes within the soil, both in the absence of higher vegetation, and also coincidentally with the growth of non-leguminous plants. He further considers that such fixation takes place to an extent which would be an important source of nitrogen to our crops. As referred to above, Boussingault's experiments of 1858 and 1859 showed fixation within the soil which he then attributed to the agency of myco-dermic vegetation. The fact of such fixation within the soil, under the influence of lower plants, has also been confirmed by the recent results of some other experimenters. Thus, MM. Schloesing  *fils* and Laurent have shown fixation in bare soil, and in soils growing various non-leguminous plants, when certain Lichens and Algæ were developed, but not when their occurrence was prevented. We believe that Hellriegel has also found fixation coincidentally with the growth of certain Algæ. Nevertheless, it may be observed, that neither experience in practical agriculture, nor the nitrogen statistics of soils and crops, points to the conclusion that there is gain of nitrogen to any material extent by the fixation of free nitrogen under the agency of microbes within the soil independently of leguminous growth. It was our intention to commence experiments on this subject at Rothamsted in the past year (1891), but we have not yet been able to do so.

In 1888, however, Berthelot made numerous experiments with *Leguminosæ*, and in many of them he found very large gains of nitrogen; indeed, a much higher range of gain than in his other experiments. That there should be large gain under such conditions is quite consistent with the results which have been recorded of the experiments made at Rothamsted in 1888 and 1889 with *Leguminosæ*, and with those previously obtained by Hellriegel and Wilfarth. Further, these results of Berthelot, like those obtained at Rothamsted and by others with leguminous plants, are consistent with well-established facts of agricultural production, and with the nitrogen statistics of soils and crops, and serve with them to aid the solution of long-recognised problems in connection with the growth of leguminous crops.

But, whether or not it may eventually be established that

nitrogen is fixed, to any material extent, by microbes within the soil, independently of leguminous growth, there is evidence that in soils and subsoils containing organic nitrogen, lower organisms may serve the higher plants by taking up or attacking and bringing into a more readily available condition combined nitrogen not otherwise, or only very slowly, available for the higher plants. For example, it is probable that fungi generally derive nitrogen from organic nitrogen; and in the case of those of fairy rings there can be little doubt that they take up from the soil organic nitrogen which is not available to the meadow plants, and that on their decay their nitrogen becomes available to the associated herbage. Then in the case of the fungus mantle, observed by Frank on the roots of certain trees, it may be supposed that the fungus takes up organic nitrogen, and so becomes the medium of the supply of the soil nitrogen to the plant. More pertinent still is the action of the nitrifying organisms in rendering the organic nitrogen of the soil and subsoil available to the higher plants. It may well be supposed, therefore, that there may be other cases in which lower organisms may serve the higher, bringing into a more available condition the combined nitrogen already existing, but in a comparatively inert state, in soils and subsoils.

But to return to the question of the explanation of the undoubted fixation of free nitrogen in the growth of leguminous crops under the influence of suitable microbe infection, and of the development of nodules on the roots of the plants.

As in the exact quantitative series of experiments made at Rothamsted in 1888 and since, some of the results of which have been given, the plants were not taken up until they were nearly ripe, it is obvious that the roots and their nodules could not be examined during growth, but only at the conclusion, when it is to be supposed that the contents of the nodules would be to a great extent exhausted. Another series was therefore commenced in 1890, and is still in progress, in which the same four annuals—peas, beans, vetches, and yellow lupins—and the same four plants of longer life—white clover, red clover, sainfoin, and lucerne—were grown in specially-made pits, so arranged that some of the plants of each description could be taken up, and their roots and nodules studied, at successive periods of growth: the annuals at three periods—namely, first when active vegetation was well established, secondly when it was supposed that the point of maximum accumulation had been approximately reached, and thirdly when nearly ripe; and the plants of longer life at four periods—namely, at the end of the first year, and in the second year when active vegetation was re-established, when

the point of maximum accumulation had been reached, and lastly when the seed was nearly ripe. Each of the eight descriptions of plant was grown in sand (with the plant-ash), watered with the extract from a rich soil; also in a mixture of two parts rich garden soil and one part of sand. The pits with their plants were exposed to the open air, but protected from heavy rain.

In the sand the infection was comparatively local and limited, but some of the nodules developed to a great size on the roots of the weak plants so grown. In the rich soil the infection was much more general over the whole area of the roots, the nodules were much more numerous, but generally very much smaller. Eventually the nodules were picked off the roots, counted, weighed, and the dry substance and the nitrogen in them determined.

Taking the peas as typical of the annuals, and the sainfoin of the plants of longer life, the general result was that, at the third period of growth of the peas in sand, the amount of dry matter of the nodules was very much diminished, the percentage of nitrogen in the dry matter was very much reduced, and the actual quantity of nitrogen remaining in the total nodules was also very much reduced. In fact, the nitrogen of the nodules was almost exhausted. The peas grown in rich soil, however, maintained much more vegetative activity at the conclusion, and showed a very great increase in the number of nodules from the first to the third period; and with this there was also much more dry substance, and even a greater actual quantity of nitrogen, in the total nodules at the conclusion. Still, as in the peas grown in sand, the percentage of nitrogen in the dry substance of the nodules was very much reduced at the conclusion.

In the case of the plant of longer life, the sainfoin, there was, both in sand and in soil, very great increase in the number of nodules, and in the actual amount of dry substance and of nitrogen in them, as the growth progressed. The percentage of nitrogen in the dry substance of the nodules also showed, even in the sand, comparatively little reduction, and in the soil even an increase. In fact, separate analyses of nodules of different character or in different conditions showed that, whilst some were more or less exhausted and contained a less percentage of nitrogen, others contained a high percentage, and were doubtless new and active.

Thus, the results pointed to the interesting conclusion that, in the case of the annual, when the seed is formed, and the plant more or less exhausted, both the actual amount of nitrogen in the nodules, and its percentage in the dry substance, are greatly reduced; but that, with the plant of longer life, although

the earlier formed nodules become exhausted, others are constantly produced, thus providing for future growth. The results of this new series of experiments, taken together with those of the quantitative series, serve further to show that there is intimate connection between the gain of nitrogen by *Leguminosæ* and the development of nodules on their roots.

The alternative explanations of the fixation of free nitrogen seem to be—

1. That, under the conditions of the symbiosis, the plant is enabled to fix the free nitrogen of the atmosphere by its leaves.

2. That the nodule-organisms become distributed within the soil, and there fix free nitrogen; the resulting nitrogenous compounds becoming available as a source of nitrogen to the roots of the higher plant.

3. That free nitrogen is fixed in the course of the development of the organisms within the nodules, and that the resulting nitrogenous compounds are absorbed and utilised by the host.

It certainly seems to us that the balance of the evidence at present at command is much in favour of the third mode of explanation. Indeed, there seems little or nothing in the facts to lead to the conclusion that under the influence of the symbiosis the higher plant itself is enabled to fix the free nitrogen of the air by its leaves. Nor does the evidence point to the conclusion that the nodule-bacteria become distributed through the soil and there fix free nitrogen, the compounds of nitrogen there produced being taken up by the higher plant. It seems more consistent, both with the experimental results, and with general views, to suppose that the nodule-bacteria fix free nitrogen within the higher plant, and that the nitrogenous compounds produced are absorbed and utilised by the plant. In other words, there does not seem to be any evidence that the higher chlorophyllous plant itself fixes free nitrogen, or that the fixation takes place within the soil; but it is much more probable that the lower organisms fix the free nitrogen. If this should eventually be established, we have to recognise a new power of living organisms—that of assimilating an elementary substance. But this would only be an extension of the fact that lower organisms are capable of performing assimilation-work which the higher cannot accomplish; whilst it would be a further instance of lower organisms serving the higher. Finally, it may here be observed that Loew has suggested that the vegetable cell, with its active protoplasm, if in an alkaline condition, may fix free nitrogen with the formation of ammonium nitrite. Without passing any judgment on this point, it may be stated that it has frequently been found at Rothamsted that the contents of the

nodules have a weak alkaline reaction when in apparently an active condition—that is whilst still flesh-red and glistening.

It will be seen that the experimental results which have been brought forward constitute only a small proportion of those already obtained, or yet to be obtained, at Rothamsted; and it is hoped that, in the course of the further prosecution of the investigations which have been undertaken, more definite answers will be forthcoming to some of the admittedly still open questions in connection with this interesting and important subject.

#### OF WHAT IMPORTANCE TO AGRICULTURE IS THE NEWLY-RECOGNISED SOURCE OF NITROGEN TO LEGUMINOUS CROPS?

The question yet remains:—What is the practical importance of the newly-recognised source of nitrogen to the *Leguminosæ*, considered in its bearing on the known facts of agricultural production, and especially on the question of the sources of the nitrogen, not only of leguminous crops themselves, but of crops generally? Unfortunately, as in the matter of the explanation of the action by which the nitrogen is fixed, there is much yet to learn before an adequate answer can be given. Still it is desirable to report progress.

We have said that whilst experience, whether practical or experimental, did not point to an unsolved problem in the matter of the sources of the nitrogen of the agricultural plants of other families, it was quite otherwise so far as those of the *Leguminosæ* were concerned. It is true, that both agricultural investigation, and direct vegetation experiment, have clearly shown that *Leguminosæ* do take up much soil-nitrogen, and, at any rate in great part, as nitrate. But it is admitted that, in the case of some direct experiments bearing on the point, the evidence was not such as to justify the conclusion that the whole of the nitrogen had been so derived; and that hence some other explanation of the large amounts assimilated was needed.

It has been seen that the balance of experimental evidence is against the supposition that the higher plants themselves can assimilate free nitrogen. But, it is now established that, at any rate in the case of some leguminous plants, they gain nitrogen coincidentally with the development on their roots of tubercular bodies containing bacteria; and the evidence points to the conclusion that it is the lower organisms, and not the higher plants, that fix free nitrogen.

It has been stated that the characteristic nodules have been



found on the roots of various leguminous plants growing among the mixed herbage of grass-land, and also on those of others growing on arable land, in the ordinary course of agriculture. There can be little doubt that, when such plants are growing in soil and subsoil containing an abundance of combined nitrogen, they will obtain some of their nitrogen from nitrates, or other ready-formed compounds of nitrogen. It has further been suggested, that lower organisms may serve the higher, at any rate in part, by bringing the combined nitrogen existing in the soil and subsoil in a comparatively inert state, into a more readily available condition. An obvious difficulty in the way of the assumption, that much of the greater assimilation of nitrogen by the *Leguminosæ* than by other plants is due to a supply of nitric acid by the nitrification of the combined nitrogen of the subsoil, is that the direct application of nitrates as manure has comparatively little effect on the growth of such plants. In the case of the direct application of nitrates, however, the nitric acid will percolate chiefly as nitrate of soda or nitrate of lime, unaccompanied by the other necessary mineral constituents in an available condition; whereas, in the case of nitric acid being formed by direct action on the organic nitrogen of the subsoil, it is probable that it will be associated with other constituents, liberated, and so rendered available, at the same time. But, so far as the plants obtain nitrogen derived from the fixation of free nitrogen, the question arises—under what conditions will this supply come the more or the less into play?

In some of the experiments made in pots at Rothamsted, the results of which have been given, there was a less development of nodules on the roots when soil containing an abundance of combined nitrogen was used, than when nitrogen-free sand was employed. But the less growth, and the less formation of nodules in the rich soil, was supposed to be due to clotting, and therefore to defective porosity, especially after watering. On the other hand, as already said, some experimenters have concluded that the activity of the process depends on the quantity of nitrogenous compounds at the disposal of the roots; the nodules developing unhindered, and becoming large and typical in soils rich in nitrogen, whilst in soils poor in nitrogen they attain no great size.

In the later series of experiments made at Rothamsted, those conducted in pits in the open air, to which brief reference has been made, the general, though not the invariable, result was, however, that there was a much greater number of nodules formed on the roots of the plants growing in rich soil than on those grown in sand. But whilst as a rule the individual, but

much fewer nodules on the roots grown in sand, developed to a much greater size; the much larger number in the soil were very much smaller.

As to the greater number of nodules formed in rich soil than in sand, the explanation may simply be that, as in the sand the infection was dependent on the additions of rich soil-extract only, the diffusion of the microbes would be only limited, and the infection of the roots therefore only local or accidental; whilst the much greater size of the individual nodules may be due to the want of power in the more weakly plant growing in nitrogen-free soil to resist the free development of the parasite. On the other hand, in the mixture of rich soil and sand, the microbes would probably be distributed throughout it, and the roots accordingly exposed to infection along their whole range. The much less development of the individual but more numerous nodules in the rich soil may be due to one of two very different causes. It may be that although the more vigorous plants grown in the rich soil could not resist the original infection, they were able to resist the further development of the parasite; or, it may be, that with the more vigorous growth the nodules were more rapidly exhausted of their contents to feed the host. It will be obvious that, on the former supposition, some of the nitrogen of the restrictedly developed individual nodules may have been obtained from the nitrogenous matters of the plant itself derived from soil-nitrogen, in which case the gain from fixation would be less than would otherwise be indicated by the great number of nodules produced; and in favour of this supposition, which implies that in the early stages of the infection the bacteria derive nitrogenous nutriment from the stores of the higher plant itself, and only later from the fixation of free nitrogen, is the fact of the observed "nitrogen hunger stage" so characteristic of plants for some time after infection, when growing in nitrogen-free soil, probably indicating that during that period the limited stores of the plant are being drawn upon. On the second supposition, on the other hand—that the smallness of the nodules was due to their rapid exhaustion by the host—it might be that more of the nitrogen of the nodules would be due to fixation, and that hence a larger proportion of the total nitrogen of the plant would be gain attributable to that source.

Obviously more evidence is needed before a decisive opinion can be formed, as to how far fixation of free nitrogen is an essential coincident of nodule-development at all its stages of accumulation, and how far therefore the amount of nodule-formation may be taken as a fair measure of the fixation.

It is to be supposed that when nodules develop abundantly on the roots of leguminous plants growing in soil rich in readily available combined nitrogen, the nitrogen assimilated will be partly due to soil supplies of combined nitrogen, and partly to fixation. That there is gain when red clover, for example, grows luxuriantly on ordinary arable soil, common experience can leave but little doubt. The evidence of fixation is, however, undoubtedly much the clearer in the case of soils poor in nitrogen. Thus, in the cases of the experiments with peas, vetches, and yellow lupins, growing in nitrogen-free but duly infected sand, there being no other supply of combined nitrogen than that in the seed sown, the proportion of the total assimilation due to fixation was undoubtedly very large. It may safely be concluded, indeed, that when luxuriant leguminous crops are obtained on soils characteristically poor in available combined nitrogen, a large proportion of the total nitrogen assimilated will be due to fixation. It is, on the other hand, by no means so clear that, when such plants are grown in soil rich in available combined nitrogen, an abundant development of nodules is to be taken as indicating that a correspondingly great proportion of the total nitrogen assimilated is due to fixation.

There can, however, be little doubt that in the growth in practical agriculture of leguminous crops, such as clover, vetches, peas, beans, sainfoin, lucerne, &c., at any rate some, and in some cases a considerable proportion, of the large amount of nitrogen which they contain, and of the large amount which they frequently leave as nitrogenous residue in the soil for future crops, is due to the fixation of free nitrogen, brought into combination by the agency of lower organisms. Evidence is, however, obviously still wanting, to enable us to judge decisively under what conditions a greater or less proportion of the total nitrogen of the crop will be derived—on the one hand from nitrogen-compounds within the soil, and on the other from fixation.

Incidentally, the question suggests itself—how far the failure of red clover, or of other leguminous crops, may be due to the exhaustion of the organisms necessary for nodule development, and for the coincident fixation of free nitrogen; how far to the exhaustion of combined nitrogen, or of the necessary mineral constituents, in an available condition, within the range of the roots; or, as is sometimes the case, to insect ravages depending on the condition of the soil independently of an otherwise failing condition of the plant.

Assuming it then to be established that a greater or less, and sometimes a considerable proportion, of the nitrogen of our

leguminous crops will be due to fixation under the conditions supposed, it is obvious that such a fact not only serves to explain the source of the hitherto unaccounted-for amount of the nitrogen of those crops themselves, but that it also affords an explanation of the source of the increased amount of nitrogen which other crops acquire, when they are grown in association or in alternation with *Leguminosæ*. Lastly, the fact that herbaceous leguminous plants (also papilionaceous shrubs and trees, as shown by Nobbe) are susceptible to the symbiosis, and under its influence may gain much nitrogen, serves to explain the source of some, at least, of the large amount of combined nitrogen accumulated through ages in our soils and subsoils, and also the comparatively slow exhaustion of their stores of it, by cropping, drainage, and in other ways.

Referring now to some of the more directly practical aspects of the subject, it may be observed that in Germany, Schultz, of Lupitz, has for some years farmed a considerable area of poor gravelly and sandy soil by growing leguminous crops—various clovers, lupins, serradella (*Ornithopus sativus*), &c., by means of kainit and phosphatic manures, and he has found the land thereby very much enriched for future cereal and other crops. He finds, however, that it is necessary to vary the description of leguminous crop grown. In various parts of Germany, too, the system is gradually extending of growing lupins, serradella, or other leguminous crops, especially on poor sandy soils, with a view to their enrichment in nitrogen. And on a large estate in Hungary it was found that the results of the recent investigations indicating the fixation of free nitrogen in the course of the development of leguminous crops were being carefully studied with a view to practical application.

In our own country Mr. Mason, of Eynsham Hall, Oxfordshire, commenced in 1889 some experiments with various *Leguminosæ* on small plots; and in 1890 a considerable series in specially-built tanks or pits, in which he has grown various leguminous agricultural plants, as well as some leguminous shrubs, with a view to the study of their root and nodule development, and the connection of these with luxuriance of growth, and gain of nitrogen. He has also devoted about 200 acres to the practical application of the recently acquired knowledge in regard to nitrogen fixation. Stated in a few words, his idea is, to reduce his area under roots, and to grow instead mixed crops of *Leguminosæ*—beans, various clovers, &c.—liberally manured with basic slag and kainit, and to convert the produce in the first year into silage, and

in the second into hay. The land is thus occupied for two years, and the assumption is, that in this way highly nitrogenous crops will be obtained with mineral but without any nitrogenous manure, and that the land will be left in high condition so far as nitrogen is concerned for the growth of saleable crops, such as potatoes, or grain, which require nitrogenous manuring. In other words, the plan is, as he puts it, first to grow nitrogen-accumulating crops for home consumption, and afterwards nitrogen-consuming crops for sale. The experiment has been in progress too short a time to judge how far it will be successful in a series of years, or of rotations. It is at any rate pretty certain that, to obtain luxuriant leguminous crops so frequently as the plan supposes, it will be necessary that the description of plant grown should be varied from time to time. It has also yet to be determined to what extent the nitrogen removed in the leguminous crops and made into silage or hay must be returned to the land in the form of manure, or whether part of the green crop itself should be ploughed in, for the after-growth of the saleable crops.

There is, of course, nothing new in the fact that, after the growth of a leguminous crop, such as red clover for example, the soil is left in a higher condition for the subsequent growth of a grain crop; and that, in fact, the growth of such a leguminous crop is to a great extent equivalent to the application of a nitrogenous manure for the cereal. Indeed, history tells us that more than two thousand years ago it was recognised by the Romans that the occasional growth of plants of the leguminous family had the effect of increasing the growth of the gramineous crops with which they were alternated, and it was stated that the effect was equivalent to that of applying manure. Thus Varro says that, "Certain things are to be sown, not with the hope of any immediate profit being derived from them, but with a view to the following year, because, being ploughed in and then left in the ground, they render the soil afterwards more fruitful;" and the plants used for this purpose were lupins, beans, vetches, and other legumes.

Now, however, that the character of the action is more clearly understood, and it is certain that there is actual gain of nitrogen from sources external to the soil itself, it seems desirable that at any rate tentative trials should be made on different descriptions of soil, with the view of ascertaining whether more advantage cannot be taken of this source of nitrogen than our established practices of rotation at present secure.

The experimental results which have been brought forward clearly establish that there is great gain of nitrogen under

some conditions. It has also been clearly shown, that due infection of the soil and of the plant is an essential to success. The evidence at the same time points to the conclusion that the soil may be duly infected for the growth of one description or some descriptions of plant, but not for some other descriptions. The field experiments on leguminous crops at Rothamsted have further shown, that land which is, so to speak, quite exhausted so far as the growth of one leguminous crop is concerned, may still grow very luxuriant crops of another description of the same family, but of different habits of growth, and especially of different character and range of roots. This result, though undoubtedly more or less due to other causes also, is, nevertheless, in some cases doubtless dependent on the existence, the distribution, and the condition, of the appropriate microbes for the due infection of the different descriptions of plant. In fact, it is pretty certain that success in any system involving a more extended growth of leguminous crops in our rotations will not be attained without having recourse to a considerable variation in the description of leguminous plant grown. Another essential condition of success will pretty certainly be the liberal application of potash and phosphatic manures for the leguminous crop. Then, the questions would arise—how long the leguminous crop should occupy the land; to what extent it should be consumed on the land, or the manure from its consumption be returned; or under what conditions the whole, or part, of it should be ploughed in? Lastly, it is probable that more benefit would accrue to the lighter and poorer than to the heavier or richer soils by any such extended growth of leguminous crops.

J. B. LAWES.

J. H. GILBERT.

## THE NITRIFYING FERMENTS OF THE SOIL.

THE salt, or chemical, known as nitrate of lime may, without hesitation, be described as the most important plant food contained in the soil. Imagine, if we can, a soil utterly destitute of it, incapable of forming it, and not supplied by manuring with any nitrogen-containing substance from which it can be formed. Such a soil, however kind in texture, however well situated, drained, and tilled, however well supplied with the purely mineral ingredients of plant food, is not capable of growing the barest pretence of a crop of corn, roots, or grass. Or consider the actual and very common case of two soils, good

and equally good in all other respects, but the one containing within reach of the roots during a season's growth twice as much available nitrate as the other. If the latter will only grow in a good season fifteen bushels of wheat per acre, the former will yield thirty; should it contain half as much again of available nitrate, it might even yield close on forty-five bushels. Yet the quantity of this most important factor of a soil's fertility present at any one time is, in relation to the mass of soil, almost infinitesimal. Place a handful of soil in the hands of a chemical student, and, unless he employs the most refined and delicate chemical tests, and adapts his plan of analysis specially to detect this ingredient, he may miss it altogether. Indeed, in some soils, and under some circumstances, as, for example, in the soil of a field of grass in vigorous growth during a showery June, or in a worked-out, sandy soil, after an autumn of persistent rains, the most sensitive chemical test will barely detect it. Sometimes there is less than one part, often less than ten parts, in a million parts by weight of soil; sometimes there is ten times as much as the larger of these quantities.

Small as are these proportions, the modern refinements of soil-sampling and of analysis permit an accurate estimate to be made in any given case, and to fix the ideas we may glean a few of the results obtained in the Rothamsted laboratory on the soil of the celebrated Broadbalk wheat field. Sampled in October, and therefore containing the nitrate (if any) unconsumed by the summer's wheat crop, and that accumulated since its removal, the plot that had grown a crop of wheat yearly for forty years without manure showed<sup>1</sup> 15 lb. of nitrogen as nitrate per acre to a depth of twenty-seven inches; the plot growing wheat every year with 14 tons farmyard manure per acre showed<sup>2</sup> 52.2 lb. of nitrogen as nitrate per acre to the same depth. The soil of another field in fair condition, bare fallowed since the harvest of the previous year, showed 60 lb. of nitrogen as nitrate per acre to the same depth.

This mode of statement is no doubt the most convenient from an agricultural point of view. It emphasizes the well-ascertained fact that the commanding influence of nitrate of lime on plant growth is a consequence of its supplying the plant with nitrogen in an immediately available form wherewith to build up the albuminoids of the protoplasmic contents of the living cells which are the plant's manufacturing organs, and

---

<sup>1</sup> Equal to 88 lb. nitrate of lime, or 108 lb. nitrate of potash, or about 12 parts of the latter per million of soil.

<sup>2</sup> Equal to 306 lb. nitrate of lime, or 376 lb. nitrate of potash, or about 42 parts of the latter per million of soil.

eventually to supply the nitrogenous ingredients of the matured plant or grain. About this there can be no doubt. A nitrate in solution is readily carried through the roots into the circulation of a plant; its presence in the leaves and stem can easily be proved by testing their juice, and it is found to be thus taken in and stored up until by the increasing demands of the growing cells it is used up in forming new compounds. *Pari passu* with this, the decrease in the nitrate of the soil can be followed by the same tests, and (if the experiment is conducted on a plant growing in a flower-pot) at the end of the summer's growth the soil will in many cases be found to be pumped absolutely dry of this particular ingredient.

To say that nitrate of lime is the *sole* natural source of nitrogen supply for any plant or class of plants would be perhaps to put the case too strongly, but this much at any rate may be said:—The illimitable supply of pure nitrogen gas in the atmosphere is only available as food in a curious indirect way to a limited class of plants having a special manner of growth (*e.g.* the *Leguminosæ*); the great stock of nitrogen locked up in the soil in the form of organic or decayed vegetable matter (some hundred or a thousand times greater in quantity than the nitrate) is not known to be *immediately* available as food to any plant; and the ammonia compounds of liquid manure, dung-heaps, guano and ammoniacal manures are certainly to a great extent *converted into nitrates* by the time the plant makes use of them as nitrogenous food. As to the lime present in the nitrate of lime, that must be looked upon as an accidental rather than an essential or even important concomitant of the nitrogen. Were potash the most abundant base in the soil, nitrate of potash (saltpetre or nitre) would be the nitrate present, and plants would obtain a more valuable food than even nitrate of lime. Were soda the most abundant base, nitrate of soda would prevail, and would be the salt absorbed by the plant to the same purpose as the lime salt. How well nitrate of soda supplies the natural deficiencies or the annual loss of our tilled soils in nitrate of lime is shown by the present annual consumption of 150,000 tons for this sole purpose.

Boussingault, the pioneer of the experimental method in agricultural science, was well aware of the importance of nitrates and of the reason of it, one of his earliest essays bearing the title "On the influence of Saltpetre on the development of Plants." As early as 1856 he had succeeded in devising a method for estimating the nitrate present in soils, and he gives us the result of testing over thirty samples. He



found the nitrate in traces only, or in very small quantities, in some forest and meadow soils and soils with growing crops; in very small quantity after very wet weather in autumn, and immediately after the growth of a crop; in larger quantities in fallow soils in a dry autumn, and in largest quantities after a long spell of dry weather during the summer. In one case he gives under 2 parts of nitrate per million in the soil of a hop field in September after heavy rains, 600 parts per million in the same soil in the following July after a long spell of dry weather, and 33 parts again in the following October. Whether his figures are strictly accurate or not, the great fluctuation in this floating capital of the soil was evidently quite familiar to him, and subsequent observers have but confirmed the general tenour of his results. Greedily absorbed from the soil by a growing crop, easily washed out of it by the winter's rains, and *accumulating or being formed in the soil* during warm and not too dry weather, and especially in fallows—these were obviously the main determining circumstances of the fluctuations.

It is only natural that the mode of formation of such a valuable substance should be an interesting and promising field of inquiry. To the natural process of *nitrification*, as it occurs in the nitre-producing villages of India, Europe has been, and still is, largely indebted for a supply of nitrate of potash wherewith to make gunpowder. The heaps of nitre-earth found near the sites of former habitations consist of house refuse mixed with porous soil, ashes from the fires, urine, &c. After long-continued exposure to Indian warmth, lixiviation of this nitre-earth with water furnishes a solution from which saltpetre is extracted by evaporation and crystallisation.

In 1777, when France could not import saltpetre, the Government caused to be printed "Instructions for the Establishment of Nitre-heaps," which Boussingault makes the subject of one of his essays, and his observations and drawings make it plain that before his time the practical conditions of nitrification were well known. Heaps of soil mixed with ashes and animal refuse, arranged in layers separated by loose straw kept under cover, freely exposed to air, and watered as often as possible with urine, turned and removed once or twice if practicable, furnished in the course of some months a notable supply of nitre. If treated after the manner prescribed, we learn that about 450 tons of material would in two years furnish about  $4\frac{1}{2}$  tons of crude saltpetre. The watering with urine was to be stopped some months before the final lixiviation. Though earth was regarded as a purely mechanical agent, and any earth not too compact

would serve, the best was known to be *that already charged with nitrate*, such as cave earth, manured garden soil, the earth in the neighbourhood of stables and refuse heaps, &c. The necessary potash of course came from the ashes, the oxygen from the atmosphere, and the nitrogen in Boussingault's time was known to be supplied by the urine and animal matter, and to be converted by the putrefaction of these into ammonia before undergoing oxidation and combination with the potash to form nitrate.

For the potash of the ashes substitute the lime of the soil, and for the nitrogen of the animal matter that of the decaying vegetable matter of the soil, which is slowly given off as ammonia during the decay, and it is seen that the formation of nitrate of lime in soil proceeds on the same lines as that of saltpetre in the nitre-heap. That the formation of nitrate is encouraged by warmth, by moisture, by porosity of the soil, by tillage and other operations favouring free admission of air, and by the presence of lime or potash, was as well known fifty years ago as it is to-day. But the combination of the atmospheric oxygen with the nitrogen and hydrogen of the ammonia resulting from decaying vegetation was then, and for very many years afterwards, supposed to be as purely chemical an action as the combination of nitric acid, once formed, with lime or potash to produce nitrate of lime or nitrate of potash.

Not indeed until 1877, when the experiments of Schloesing and Müntz threw an entirely new light upon the matter, was any other opinion generally entertained, although Pasteur himself had in 1862 suggested as probable that the oxidation in this case, as in the familiar one of the conversion of wine or beer into vinegar, might be due to the action of a living ferment, and not to simple contact with the air. Fifteen years after this suggestion the first experiments confirming it were published, and not until the present year, that is after the lapse of nearly fifteen years more, has the prediction been fully and completely verified by the isolation and separate examination of at any rate two of the species of organisms concerned in the process. So slow in certain cases is the onward progress achieved by what we are accustomed to regard nowadays as the rapidly advancing strides of science! A short sketch of the hunt after these organisms which followed on the publication of Schloesing and Müntz' results will disclose some reasons for the slow progress in this case and will be instructive in other ways. Much light has been thrown on the obscure process of nitrification, and the organisms at last identified as being the true agents are so sin-

gular in their mode of growth as to differ from all living organisms previously known.

When a chemical transformation is carried on by the agency of a living ferment (as the fermentation of sugar into alcohol by the yeast plant), the vital nature of the process is clearly pointed out by symptoms which a few very simple tests suffice to disclose. The symptoms which led to Schloesing and Müntz' conclusion were the stoppage of nitrification by antiseptics, and the power of provoking it in a suitable medium by simple *inoculation* with soil. Sewage, as is well known, contains ammonia, and one of the principal actions taking place when sewage is purified by irrigation or filtration through soil is the nitrification of this ammonia. The French observers, experimenting on the purification of sewage, were filtering it through a mixture of sand and limestone. Not until twenty days did any nitrification take place, but then the material nitrified the sewage completely and continuously for four months. But on exposing the filtering medium to the vapour of chloroform (which is fatal to microbes) nitrification stopped, nor, after sweeping away all trace of the chloroform by a fresh current of sewage, was the process found to commence afresh, even after seven weeks' trial. The filtering column was then inoculated or seeded by pouring on it a few scruples of garden soil suspended in water, and eight days after this the current of sewage was nitrified as at first.

This striking result determined Warington to take up the study in the Rothamsted laboratory, with the immediate result of proving that bisulphide of carbon and carbolic acid, two other antiseptics, are, like chloroform, inimical to nitrification, and that darkness favours it, as it does many other bacterial processes. He also showed that dilute solutions of ammonia salts supplied with small quantities of plant food readily nitrify when inoculated with garden soil or with a few drops of a solution in which nitrification has commenced, but do not do so when this inoculation is omitted.

Experiments on such nitrifying solutions form the basis of most of Warington's investigations on the subject, which are detailed in a series of connected papers appearing in the *Chemical Society's Journal* in 1878, 1879, 1884, and 1891, and in papers dealing with separate aspects of the question appearing in 1885, 1887, and 1888. Facts in abundance, all confirming the ferment theory of nitrification, were soon adduced by him and by other experimenters. Thus the boiling of a solution after inoculation is sufficient to prevent nitrification altogether, and to stop it if it has commenced. Such a boiled solution may be kept for years without change provided the dust

of the air, which *may* carry in nitrifying germs, but does not always do so, be simply excluded by a plug of cotton-wool. Nay, the mere heating to 104° F. is fatal, and we infer that at this temperature the active organisms are killed. The temperature at which nitrification is most rapid is given by Schloesing and Müntz as 98°–99° F. Cold, of several degrees below freezing, as might be expected, is not fatal to the organisms, but it entirely suspends their activity, which, however, is manifested by a very slow nitrification at temperatures as low as 38° F. Baked soil has no power of starting nitrification. Traces of lead and mercury salts, salicylic acid, and most other antiseptics are fatal to the process; and the absence of sufficient quantity of some base, such as lime, potash, soda, ammonia, or magnesia, will cause it to stop the moment the base is used up, although it may be re-started at any time by adding a little of any one of these bases in the form of carbonate. If added in the pure or caustic state they may kill the ferment.

As might be expected, not only ammonia salts but all nitrogenous substances capable of yielding ammonia by putrefaction or decay are eventually nitrified by the action of soil. Warington records many experiments of this sort with asparagine, milk, urine, rape-cake, &c., and the author has succeeded not only with urea and gelatine but with such simple nitrogen compounds as ethylamine and sulphocyanates. Should, however, the nitrogen compound be itself an antiseptic, it is not susceptible of nitrification; thus thiocarbamide, a compound containing precisely the same elements and in the same proportions as ammonium sulphocyanate, failed to nitrify.

Many experiments were made by the method of inoculating suitable ammoniacal solutions, to ascertain the distribution of the nitrifying ferments in nature. Warington, summing up a number of trials, tells us that all samples of soil taken down to two feet in depth provoked nitrification, but that over this depth failures to nitrify increase in number, and at a depth of six feet and over the soil has lost this power. From this and other experiments it is certain that the first few inches of surface soil contain the ferments in vastly greater proportions than the subsoil. From the soil these ferments get into waters, and the power which rivers and wells possess of ultimately converting the ammonia of sewage into nitrate of lime depends on their presence. The writer, examining in 1886 various samples of river and well water, found that inoculation with one to five drops of any of them was sufficient to bring about nitrification in a suitable ammoniacal solution, but that rain water caught in a perfectly clean vessel is destitute of the power.

All these facts, and many others which there is no space to detail, were perfectly congruous with the theory of a living nitrifying ferment or ferments, and, indeed, were not explicable on any other theory. But they went no distance towards isolating this ferment from the many species of microbes which inhabit the soil, in order to study its form, mode of life and reproduction, and its chemical activity in pure cultures like those of the yeast plant. Though no success attended the earlier efforts, they rendered it probable that the nitrifying power is not common to many microbes, but probably confined to one or two distinct species. Experiments with some of the common moulds, with yeast, and with the vinegar ferment were made by Schloesing and Müntz with negative results. The same observers published in 1883 a short account of what they took to be the real nitrifying microbe (separated to some extent from its associates by successive cultivations in suitable liquids), which they describe as a small, nearly round *micrococcus*, but in the light of our present knowledge it is certain that although they doubtless saw one or more of the organisms producing nitrification, they could not have accomplished the isolation of these in a pure state.

Two unexpected facts which had cropped up were destined to have an important influence in the solution of this problem, although their true bearing was not seen until much later. Warington, and all after him who carried out nitrification in liquid media, found the phenomenon to differ greatly in one respect from what takes place in the soil and in natural waters. For whereas, in soils and waters, we can rarely trace any intermediate compound between the ammonia which is being nitrified and the nitrate which is formed, the contrary is the general rule with artificial solutions. In nearly all of these a *nitrite* (that is a salt of nitrous acid containing an equivalent less of oxygen than the corresponding *nitrate*) is at first formed; often no nitrate is produced until the whole of the ammonia has passed into the form of nitrite; and in some cases it was observed by Warington and by the writer, that the action went no farther than the production of nitrite, which remained permanent, though as a general rule the nitrite eventually, and sometimes with great suddenness, was entirely converted into nitrate.

Now, nothing is easier than to produce nitrites *from* nitrates by abstraction of oxygen, and many different species of microbe have been found to possess the power of doing this in the presence of organic matter, which they can burn up by the consumption of this oxygen. It was natural therefore for Gayon and Dupetit to suggest that the nitrites formed in artificial nitrification were really products of the *reduction* of

the nitrates at first formed by the action of these reducing microbes, many of which are present in the soil. The writer succeeded in disproving this by showing that nitrates are *not* reduced by the microbes of soil in the absence of organic matter other than that in the soil, but that under the same circumstances both nitrites and nitrates are freely produced from ammonia. The production of nitrite therefore remained as a usual characteristic of artificial nitrification not traceable in the natural process.<sup>1</sup> By varying the conditions, either nitrite or nitrate could certainly be produced at will, even in liquid media; a high temperature, a small dose of inoculating material (soil or solution), a strong ammoniacal liquor, and a deep layer of it, being favourable to nitrite production, whilst with much soil, a low temperature, dilute solutions, and shallow layers freely exposed to air, nitrates could be produced without any intervening nitrite. But having once produced nitrite, we could not at will determine its transformation into nitrate except by re-inoculation with soil.

What was the meaning of this? Were there two organisms or species, one stopping its work at the production of nitrite, and the other carrying on the process? Or did the methods of cultivation modify the activity of the nitrate-producing ferment and render it unable to complete its natural work? These questions could only be answered decisively by successful isolation of the nitrifying ferments, the very existence of which some chemists were disposed to doubt anew as time went by and no announcement of their isolation appeared.

The other unexpected fact came out in 1886, when the writer published experiments showing that nitrification had taken place in solutions to which no organic matter had been added except that in the drop of inoculating material; and this induced him to state the question, "Is organic carbon essential to nitrification?" In many other of his experiments the presence of organic matter was seen to be distinctly antagonistic to any nitrification provoked by the necessarily impure inoculations with soil, ordinary waters, or nitrifying solutions, all of which contain abundance of miscellaneous microbes, some of which are sure to flourish and take the *pas* of the nitrifying ferments in the organic medium provided. A little sugar, tartaric acid, or other carbonaceous compound had hitherto been included by all experimenters in the cultivation media, for the purpose of supplying the nitrifying organisms with carbonaceous food, it being the universal:

---

<sup>1</sup> The writer has, however, found considerable quantities of *nitrite* in the effluent from the soil filtering-beds of sewage farms.

received opinion at that time that only plants furnished with green leaves or cells are capable of obtaining their carbon from the carbonic acid of the air, and that all fungi, microscopic or otherwise, destitute of green colouring matter, are compelled to take their carbon from organic substances ready formed or in process of decay. It certainly did not occur to the writer that the nitrifying microbes could dispense with this supply of carbon altogether, but he believed the merest accidental traces to be sufficient, and especially recommended boiled pure well water, with the addition of a little potassium phosphate, as the most suitable medium for cultivations, containing as it does lime and all the necessary mineral food, with but little organic matter, and that incapable of encouraging most foreign bacterial growths. This was actually the medium in which Winogradsky subsequently obtained his first approach to pure cultures.

The systematic attempt to cultivate the nitrifying bacteria by the methods in vogue amongst bacteriologists for all hitherto known microbes led in Winogradsky's and other hands to some remarkable results. The gelatine method of obtaining pure cultivations of a particular microbe from a medium containing several is the one most often resorted to. In principle it consists in inoculating a slab of solidified nutrient gelatine, containing all materials most favourable for the sustenance of bacteria, and carefully sterilised by heat and preserved in sterilised tubes, with a thin streak of inoculating material on the end of a clean platinum wire. On subsequently keeping the slab in a warm chamber, the isolated spores introduced with the droplet of liquid grow in isolated spots on the gelatine, forming little colonies of microbes, readily distinguished one from another by their appearance; on re-inoculating a suitable sterilised solution from *one* of these colonies, a pure cultivation of that particular microbe is usually obtained.

Heraeus, isolating in this way four species of microbe from a nitrifying solution seeded with garden soil, and testing them by inoculating them into fresh ammoniacal solutions, claimed nitrifying powers for them all; he went even farther, and claimed the same powers for several disease-producing microbes which had been isolated by the labours of pathologists. It seems certain that Heraeus did not produce real nitrification with any of these, but mistook the traces of nitrous acid naturally found in solutions exposed to the air for products of their activity. Warington, examining in this way four organisms isolated on gelatine from nitrifying solutions or soil, and twenty others from other sources, failed to find any of them capable of

nitrifying. Dr. and Mrs. P. Frankland, who took up the search on the same lines, obtained thirty-three distinct microbes in pure cultures from air and water, but not one had any nitrifying power. Adametz similarly isolated twenty-two, and Frank, a number of organisms from soil, and tried them with similar negative results. To these and other negative results of other observers must be added the gelatine cultures of Winogradsky, who has published during the last two years, in the *Annales de l'Institut Pasteur*, the most searching and the most successful series of memoirs on this subject, and has at last cleared away much of the mystery surrounding it.

Having formed the idea that the failures recorded were possibly due to *inability of the nitrifying organism to grow on the gelatine slabs*, Winogradsky proceeded to try whether by cultivating successive generations in ammoniacal liquids favourable to nitrification and unfavourable to other fermentations he could not get rid of all organisms able to grow on gelatine, whilst still preserving his nitrifying organisms intact. Very soon abandoning organic matter as an ingredient of his liquid medium, and using Lake Zurich water, with no addition but the ammonia salt, a little potassium phosphate, and some magnesium carbonate, he found, after successive inoculations extending over several months, that only five species which could be isolated on gelatine persisted in living in the medium employed, and not one of these would start nitrification. But the carbonate of magnesia at the bottom of the flasks had altered in appearance; instead of being powdery it had become gelatinous or flocculent, and could not easily be shaken up with the liquid; under the microscope, particles of carbonate were seen to be invaded with masses of an oval bacterium, and bits of this deposit, inoculated into fresh solutions, were far more powerful in exciting nitrification than a drop from the middle or surface of the liquid. Here, then, was probably the nitrifying organism comparatively pure, and on shaking up a little with water and inoculating gelatine slabs with the mixture, it was found that only colonies of the non-nitrifying microbes already mentioned slowly grew and invaded the inoculated spots—in other words, the oval bacterium of nitrification would *not* grow on the gelatine, and it was still adulterated by others that *would*.

It was only at this stage that Winogradsky abandoned the lake water in favour of the purest distilled water, and banished, as far as possible, every trace of organic matter as affording food for these foreign organisms. Specially purifying all his materials from every trace of organic matter, he found that nitrification went on as well and rapidly as ever, whilst even in the



second culture, four out of five of the foreign organisms had disappeared; the fifth could not be got rid of, even by a series of cultures, and it remained the only organism in the liquid that would grow on gelatine, and yet not the one producing nitrification.

By making use of the inability of the latter to grow on gelatine, Winogradsky at last got rid of its one remaining troublesome companion. Shaking a little of the deposit with pure water, and dropping separate drops of this on a gelatine slab, after incubation for ten days it was seen that some only of the drops grew the colonies of the foreign microbe—and by seeding an ammonia solution with a particle of deposit carefully removed from one of the sterile drops, nitrification was produced and a liquid obtained in which the nitrifying ferment was allowed to grow until a sufficient quantity was obtained in a pure state for examination.

Just before the announcement of this successful result, Dr. and Mrs. P. Frankland also succeeded at last in isolating a nitrifying organism. A series of no less than twenty-four successive cultures in ammoniacal solutions free from organic matter had all given colonies of microbes on gelatine which had no nitrifying power; by combining the method of *attenuation* with that of successive culture, however, *i.e.* by adding a few drops of the medium to a body of water, and then seeding a fresh solution with a drop of this liquid, they succeeded. By seeding successively with dilutions of  $\frac{1}{100000}$ ,  $\frac{1}{1000000}$ ,  $\frac{1}{10000000}$ , &c., a point is always eventually reached where the inoculation fails to produce nitrification, and selecting always the weakest inoculation which succeeds in nitrifying, it is possible to find that no foreign organisms have been introduced. At length they found themselves with a nitrifying solution refusing to give a growth on gelatine, but containing a nitrifying organism which seems to agree with the description given by Winogradsky.

Only a month or two after this Warrington succeeded, also by the method of attenuation, in producing from cultivations made in the absence of organic matter a similar result, the absence of any growths on prepared gelatine being taken as a proof of the absence of foreign organisms.

All these results made it clear that the exclusion of organic matter from the cultivation media is vital to success in isolating these organisms, and Winogradsky, in successive endeavours to obtain a solid medium on which they could be grown in pure colonies, was not successful with any gelatinising medium of an organic nature. But by employing a purely inorganic jelly, *i.e.*, *soluble silica*, purified by long-continued dialysis, and caused to

set into a solid jelly by the addition of a little of the liquid to be nitrified, he has achieved complete success. By stabbing or spotting a sterilised slab of this with a wire dipped in a nitrifying culture, it is found that the foreign microbes will not grow, whilst the nitrifying organisms will, and soon nitrification can be detected all through the jelly (the writer has succeeded in repeating this experiment). By this improved process the organisms can be much more rapidly obtained from soil than by any other, and also in greater purity, for, as Winogradsky has shown, it is not a safe assumption that a liquid which will give no colonies on gelatine after a few days' incubation is *absolutely* free from microbes other than the nitrifying ones. Grown in a pure solution inoculated with a colony from the silica jelly, these organisms are seen to consist of an oval or nearly round *coccus* or *bacillo-coccus*, of varying size, reaching nearly  $\frac{1}{12000}$  inch diameter in the largest.

The antagonism of the nitrifying ferments to organic matter has received from Winogradsky a most striking explanation. He has shown that they obtain their supply of carbon in a manner unique amongst known living organisms, namely, from the carbonic acid of the carbonate of lime or carbonate of magnesia contained in the soil or added to the liquids in which they are cultivated. Indeed, these mineral particles are, in an old nitrifying solution, seen by microscopic inspection to be literally eaten or dissolved away by attacking masses of the organism, which thus present a perfectly characteristic appearance.

The importance of this discovery is very great; it reveals an entirely new property of living things, that namely of building up from the carbon of *mineral carbonates* and the nitrogen of ammonia, the complicated albuminoid and other organic constituents of living cells. It appears that about thirty-five parts of nitrogen in the form of ammonia have to be oxidised to a nitrite for one part of carbon taken in as food by the ferment, and it is the heat evolved by this large oxidation that furnishes the force necessary to effect the decomposition of the carbonate. Winogradsky speculates on the *rôle* these organisms may play in nature in preventing the accumulation of the supply of carbonic acid in the form of mineral carbonates (as is well known, chalk and other carbonates of lime are formed in the first place by the agency of life). Another fact of a remarkable nature soon appeared.

The purified organisms of Frankland, Winogradsky, and Warington, whether identical or not, agreed in this, that, although they would entirely nitrify ammonia, they would con-

vert it into a nitrite only and not into a nitrate; and therefore, as Warington remarks, they had "solved only half the problem of nitrification." The key to the remaining half was announced by Warington in June of this year, and by Winogradsky in July. Both have since published extended memoirs dealing with the subject.

Although a particle of soil added to a suitable ammoniacal solution will convert the ammonia first into nitrite and then into nitrate, and if sown in a suitable solution of nitrite will easily convert that into nitrate, yet the effect of successive cultures in these two different media is to bring about a decided difference in the power of the ferment. After a few cultivations in ammoniacal liquids the power of affecting nitrites is lost, as we have seen; but it is equally true that after a very few cultivations in nitrite the power of affecting ammonia is lost. By proceeding in this way with one of his old liquids, using the method of successive cultivations in nitrite solutions combined with that of attenuation or dilution, Warington has produced a nearly pure cultivation of an organism, which as he asserts, and as I have verified at his request, has absolutely no power to oxidise ammonia, though easily converting nitrite into nitrate. Winogradsky, by cultivating particles of soil in nitrite until the power of attacking ammonia is lost, and then growing colonies on gelatinous silica, has obtained in a pure state an organism having the same properties, though not agreeing in form with that found by Warington. This, however, is less remarkable, since the nitrifying organisms separated by Winogradsky from soils of different origin are by no means identical in appearance, nor (and this is an important practical point) are they by any means possessed of the same energy.

Amongst soils obtained from several parts of the world, Winogradsky finds that one from Quito contains a nitric ferment of quite exceptional energy. On the other hand, the European soils of Zurich and Gennevilliers contain a nitrous ferment of greater activity than those from exotic soils. The writer is examining in the same manner some varieties of English soil. According to Warington, pasture soil is much better supplied with the nitrous ferment, or worse supplied with the nitric ferment, than arable soil. Many points in the action of these ferments still require study, but we now know that the formation of nitrates in the soil is accomplished in two stages, by two distinct species of organism, the *nitrous* and the *nitric* ferments, neither of which can do the work of the other, but the latter waits to complete what the former began.

Doubt on this point is removed by the result of inoculating

soil sterilised by heat with pure cultures of the nitrous and the nitric ferment. A little ammonia added to the soil inoculated with *nitrous* ferment is speedily oxidised to nitrite, which persists, whilst ammonia added to the soil inoculated with *nitric* ferment is not altered. On adding ammonia to soil inoculated with *both ferments* it is oxidised to nitrate with scarcely a passing trace of nitrite, just as we find happen in natural unsterilised soil. Things happen differently in liquid cultures because of the restricted supply of air. The nitrous ferment, which is larger, much more conspicuous in development, and much more active in causing oxidation than the nitric ferment, hinders the development and activity of the latter so long as there is any ammonia present to attack. The nitric ferment, like the nitrous, refuses to grow on gelatine, and thrives in liquids absolutely free from organic matter. In all probability, though this has not yet been directly established, it obtains its supply of carbon from mineral carbonates in the same way as does the nitrous ferment. When grown in quantity in a transparent liquid, it coats the bottom of the vessel with an excessively thin, adherent film of a bluish grey colour. This gelatinous layer is seen under the microscope to be made up of masses of a very minute bacterium, whose length is greater than its width, but does not exceed  $\frac{1}{50000}$  of an inch (Winogradsky).

The slow action of both ferments in comparison with better-known ones is well worthy of remark. In pure cultivations under favourable conditions an inoculation of the nitrous ferment only develops in sixteen days sufficiently to oxidise  $\frac{1}{5}$  of a grain of ammoniacal nitrogen per day. The nitrous ferment is still slower—after an intensive culture of six weeks it was nitrating only  $\frac{1}{6}$  to  $\frac{1}{7}$  grain of nitrous nitrogen per day. We have only space to add that from some experiments of Müntz on the nitrification of nitrogenous matter in presence of sea salt, it would seem almost certain that the Peruvian deposits of crude nitrate of soda are the results of a gigantic nitrification which formerly went on in the drying up residues of salt lakes. The same observer has found in the earth of the nitrifying cave-deposits of Venezuela a nitrifying organism which he describes as three or four times the size of that found in French soil.

The practical point should not be lost sight of that nitrates are destroyed much more easily and much faster than they can be formed. A free supply of air above all things favours their preservation, whilst the presence of organic matter in the absence of air is certain, under natural conditions, to result in their destruction. This work, too, is brought about by microbes, and is a property common to a great number of different species.

Some of these are capable of destroying in a few days as much nitrate as is formed in months or years. Fortunately the activity of these baneful species can always be kept in abeyance by the aëration of the soil brought about by drainage and good tillage.

J. M. H. MUNRO.

## SALE OF CORN BY WEIGHT.

THE advantages of the sale of live stock and other agricultural commodities by weight have of late been prominently brought under the notice of the farming interest in a variety of ways, and I think it may not be inappropriate if, at the present juncture, attention is drawn in the pages of the Journal to the highly important subject of the establishment of a uniform weight for grain, which a Select Committee of the House of Commons was appointed last session to consider. The reference to this Committee was as follows:—

To inquire and report upon the various weights and measures used for the sale of grain throughout the United Kingdom; the desirability of selling grain by weight only or by measure and weight, and, in the event of either being considered desirable, the extent to which either might be enforced; the desirability of the adoption of a uniform weight, either for the United Kingdom or any part of it; if a uniform weight is desirable, the standard to be adopted, and whether there should be one standard for all kinds of grain; and, if not, what should be the standard for each kind.

Unfortunately the time at the disposal of the Committee was too short to enable it, before Parliament rose, to examine more than one witness, Mr. H. J. Chaney, the well-known Superintendent of the Standards Department of the Board of Trade. Nevertheless, so much information of value was brought out in the course of Mr. Chaney's examination, that it appears worth while, even in the present incomplete condition of the labours of the Committee,<sup>1</sup> to attempt to summarise the existing

<sup>1</sup> The *pro formâ* report of the Committee, with the documents laid before it has been published as a Parliamentary Paper, No. 347 of Sess. 1891 (Eyre & Spottiswoode, price 6½*d.*). It contains, in addition to Mr. Chaney's evidence, (1) Returns from 1,500 inspectors, employed by the Standards Department, of the weights used in the different districts of the United Kingdom. (2) A paper showing the weight of a Winchester bushel of different grains as established by law, in the different States and Territories of the United States, in pounds avoirdupois. (3) A note on the Winchester bushel and heaped measure. (4) A memorandum on the use of the instruments known as "Corn hoppers" and "Chondrometers," the former for obtaining uniform measure, the latter for testing the quality of grain. The former is in use in the City of London and in Scotland, and is

state of the question, since it is one which is likely to attract considerable public attention in the near future.

Both Mr. Chaney in his evidence, and Dr. Gilbert, F.R.S., in a letter addressed to me as chairman of the Committee, and published in its Proceedings, speak in favour of sales of grain by weight. Mr. Chaney, answering a question of mine, says that, "speaking generally, but with no desire in any way to suggest legislation, as my own individual opinion, and not the opinion of my department, I think there can be no doubt that weight is better than measure" (Q. 29). And, in reply to a further question by Mr. Seale Hayne, Mr. Chaney says, "Judging from one's experience of what has happened in the sale of other commodities, I have no doubt in my own mind that it would be far better, and that it would avoid a great amount of trickery, if all corn for wholesale purposes was required to be sold by weight only" (Q. 124). Dr. Gilbert, summing up the results of three elaborate memoranda which he had prepared on different aspects of the question, observes, "The facts and statements embodied in the [above] documents forcibly illustrate the importance of adopting a uniform weight for the sale of wheat, whether home grown or imported, and, *mutatis mutandis*, for the sale of other descriptions of grain or corn." Dr. Gilbert expresses the opinion that the weights adopted should have reference to long-recognised measures. "There would, of course," he says, speaking as a statistician, "be some advantage in adopting some uniform weight, such as the hundredweight, for all descriptions of corn, especially if such weight sufficiently corresponded with the recognised or adopted weights used in foreign countries. But our hundredweight corresponds with 1·016 Zollverein centner, and to 50·8 kilogrammes, or 2 cwt. to 101·6 kilogrammes; and these differences, which amount to nearly 2 per cent., are too great to allow of the use of the hundredweight and these foreign weights interchangeably, *i.e.*, without allowance or calculation, in international transactions or statistics." His conclusion, therefore, is in favour of a bushel of uniform weight for the sale of each description of corn, whether home grown or imported.

---

especially appreciated by the Army Service Corps, who use it at Woolwich. The latter is a small instrument 10 inches long packed in a case, which any farmer can use to test the quality of grain. (5) An account of experiments on the vertical and lateral pressures of granular substances, by Mr. Isaac Roberts, F.R.S., from the Proceedings of the Royal Society, 1883, Vol. XXXVI. No. 229, in which he shows results contradictory to our knowledge of the laws governing the flow and pressures of fluids. (6) Papers by Dr. Gilbert and Sir John Lawes, Bart., of Rothamsted, on the adopted weight per bushel of home and foreign wheat, on the adopted estimates of the amount of wheat the imported wheatmeal and flour represent, and the methods of obtaining and recording the agricultural produce statistics.—R. J. M.

One weight and one measure were extended throughout the kingdom by Magna Charta, the thirty-eighth and last ratification of which was in the reign of Henry VI. In the early Acts relating to the importation and exportation of wheat, the quarter is used. The English standards were in use in Ireland as early as 1495, and successive Acts produced a result of uniformity which has lasted till the present day. Ninety-seven per cent. of the Irish markets are found to use an uniform weight, namely the hundredweight for wholesale, and, for retail purposes, the stone of 14 lb.—the weight from which the hundredweight was obtained by three processes of doubling—whilst all the Irish agricultural statistics are returned in hundredweights.

In Scotland, Mr. Chaney is of opinion that there is a larger number of units in force than in England, owing to the fact that the old Scotch standards are still occasionally referred to. But the Corn Association of Glasgow, through which city probably more corn passes than through all the other towns of Scotland put together, has been the first to meet, and to pass a unanimous resolution in favour of the sale of grain by weight only, that weight being the 112 lb. The Association of Royal and Municipal Burghs of Scotland generally petitioned in favour of a Bill I introduced this year to abolish measure, as a means of paving the way for a uniform weight, or for drawing attention again to the question. The grain markets of Edinburgh, Stirling, and Ayr are next in importance to the Glasgow market, after which the other towns, as I am advised, are much on an equality as regards the sale of grain. I am in hopes that the Highland Society, who discuss such questions, will aid us to the best knowledge of what the opinion of the Scotch farmers on this question is likely to be. I am informed they are mostly anxious to retain a bushel of 40 lb. weight for oats, which probably may be a more correct weight than the 39 lb. bushel, made the standard by the Corn Returns Act of 1882, and which I hear the Board of Trade have resolved to adopt as the Imperial weight per bushel for oats instead of 39 lb.

The Act of 1882 showed a kindly leaning to the farmers in possibly underestimating the weight that might more generally be required, in making the imperial bushel of wheat 60 lb., of barley 50 lb., and of oats 39 lb. So little, however, did this well-intentioned Act secure uniformity, that few people in country markets know what the imperial standards are. When it is considered that all the multitudinous weights of the country are expected to be converted by the corn inspectors into measures of these weights for the Corn Returns (which regulate, amongst other things, the value of more than four millions' worth of

annual income arising from tithe rentcharge), and that some part, though a constantly diminishing and now a comparatively insignificant part, of these Returns are made in measure only, unaccompanied by any weight, the saving of trouble and the sense of greater accuracy which would result from a uniform weight is obvious.

The importance of a correct quotation of the price of corn in the interests of the public generally was particularly insisted on by the Select Committee (of forty-one members) who reported on this question in 1834. This would appear to be almost a truism. The iron trade formerly used three weights, but they met and reduced these to one, and did so in the interests of the employés. The Committee of 1834 considered uniformity of chief importance in the interests of the farmers themselves, as well as of the public, and that the legislature should step in and do what individuals, classes, or districts could not do for themselves. The tendency to sell by measure is found mostly in the Eastern counties, which may have been the result of the corn duties they so much regretted to see abolished. As, however, these counties have had to pay a much larger amount of tithe rentcharge than other counties, we might have supposed, if they had been led to consider the importance of correct corn averages in connection with tithe rentcharge, they would have felt greater interest than the Midlands in having correct quotations. Their alleged desire to sell the one cereal, barley, by measure, however, appears to operate in a contrary direction.

The Scotch have a fiars court (this word meaning average) to determine each year the annual value of grain in the county, on which, as well as other products of the soil, varying in different counties, the minister's salary is fixed. They experience, therefore, no such dissatisfaction as we do when the tithe is fixed on corn averages obtained in a way never likely to give satisfaction to those who know that the same lot of corn is returned sometimes as many as six times at Mark Lane, giving a totally erroneous impression of the amount of grain in the market, and tending to raise the average price unfairly.

The Select Committee of 1834, already referred to, made an exhaustive inquiry into the weights and measures by which grain was sold, two years before the passing of the Tithe Commutation Act. That Act adopted the well-known plan of finding the gross average money value of the tithes of each parish for seven years ending Christmas 1835; secondly, of apportioning the amount of that value upon the lands of the several tithe payers; thirdly, of ascertaining how much corn can be purchased with such amount, one-third of it to be laid out in



wheat, one-third in barley, and one-third in oats, at their average price ascertained by the weekly official returns of the price of corn in 120 markets the seven years preceding Christmas 1835; fourthly, in every future year to make payable the price of the same quantity of wheat, barley, and oats at the average prices founded on a like calculation of the returns for the seven years ending at each preceding Christmas. A similar system applicable to rent had been in practice in Scotland, and gave satisfaction, because it fixed the amount of the rentcharge in grain, whilst it allows of a variation in value according to the average market price of the grain of which the rentcharge consists. But the reason for choosing this principle for the commutation of tithe, namely, that the value of grain would be found more constant than money, has proved, as Earl Grey, the only survivor of those who passed the Tithe Commutation Act of 1836, has confessed, a considerable mistake.

No consideration of using for tithe purposes the corn averages which then existed was present to the members of the Committee of 1834. In their exhaustive report, occupying thirty pages, the two feelings that predominate are, first, that the public have a right to know the true price of grain on which so many transactions of life are based; secondly, that the farmer is placed at a disadvantage with the dealer who is experienced in these weights, and from lack of equal knowledge does not get the full price for his grain, and that if a uniform system might be objected to by other classes as inconvenient, yet the interests of the farmer should predominate to cause this to be done.

Mr. Talbot, when Secretary of the Board of Trade, moved for a return of the different weights used in the markets from which corn returns were made, and I moved in 1887 for a return of the fiars prices in Scotland, and of the returns made from the markets selected for making the corn returns, which showed a remarkable number of "nil" returns, and the very small quantities returned from other markets.

Mr. Chaney handed in to the Corn Sales Committee a summary of returns from the principal inspectors of weights and measures throughout the United Kingdom, from which the analysis given on page 722 has been made. With respect to these returns, and the difficulty of their preparation, the following explanation was given by Mr. Chaney:—

It is almost a matter of opinion with local officers as to what is the meaning of weight and what is the meaning of measure. That difficulty may also have arisen when the Corn (Measures and Weights) Returns were made in 1870 and 1879. Hardly two officers agree as to what is weight, and what is measure. In a sale by the bushel, for instance, the bushel is merely the unit of measure; the bushel is filled and its weight determined,

and the remainder of the corn is more often than not delivered by weight. Some officers regard that as a sale by weight, other officers regard it as a sale by measure, and in the preparation of the returns there is that difficulty to deal with, for which reason we have introduced the term "measured weight," which means that the corn is sold by the "bushel" or "quarter" of a fixed weight. (Q. 44.)

No. of counties and towns in which		Wheat	Barley	Oats
1. Sale by weight only . . . . .	England	68	66	65
	Wales	1	1	1
	Scotland	13	14	14
	Ireland	96	93	96
2. Sale by measure only . . . . .	England	29	32	29
	Wales	—	—	—
	Scotland	8	8	8
	Ireland	4	7	4
3. Sale by weight or measure combined, or by measured weight.	England	66	65	68
	Wales	16	16	16
	Scotland	25	24	25
	Ireland	1	—	—

The evidence given by Mr. Chaney before the Committee is, from the nature of things, a little difficult to present in a connected form; but I do not know that the question could be summed up more succinctly than in the following colloquy between him and Mr. Mark J. Stewart, M.P., who took up the examination of the witness after his answer to Mr. Seale Hayne's question No. 124, recorded in a previous paragraph.

Q. 125. I suppose you are aware that at least in Scotland the larger proportion of the corn is sold practically by weight; you sell so many bushels, we will say, and the weight is guaranteed?

A. Yes.

Q. 126. Of course if you did away with the bushel it would rather complicate matters, would it not? If I say that I have 100 bushels to sell it is a simple mode of expressing it, always with an underlying supposition that that 100 bushels is sold by weight?

A. I think it would simplify matters to separate the actual mechanical weighing and measuring of the commodity from any consideration as to its quality. That has been the mistake in past legislation, I think; I think an order, for instance, should go for so many hundredweights or tons. The question as to the quality is one that the purchaser and the seller would see to.

Q. 127. The quality is generally determined by the weight, is it not?

A. As in the case of other matters, bread, coal, gold, and so on, it is determined by certain magnitudes settled between the buyer and the seller.

Q. 128. How do you distinguish between measured weight and measure and weight?

A. Where the bushel of grain is required to have a given fixed weight, that is, according to this return, a sale by measured weight; but where the order has been given by weight, the corn to be afterwards measured, as it

sometimes is, that is measure and weight. The practice in Norfolk, for instance, is sometimes to advertise corn for sale of a certain measure, although it is subsequently sold by weight.

Q. 129. In your opinion it would be very desirable to have all corn sold by weight rather than by measure and weight?

A. My opinion, taken as I have already suggested it should be, is that it would be desirable to have it sold entirely by weight.

Q. 130. I suppose you will admit that in a given district there is not much difficulty, but that when you come to have more extensive dealings, for example, Scotland with England, then all these different weights come to be a very serious matter?

A. Very serious: but I am sure that no legislation, even if any should be attempted, would be successful unless it dealt with the whole of the United Kingdom.

Q. 131. But there would be a good deal of difficulty, would there not, attending a rapid change in the law?

A. I think this question needs discussion, and discussion might prepare the way for legislation. Farmers and dealers generally have expressed an opinion in favour of weight, an opinion which the Board of Trade listened to when they legalised the cental in 1879; but the bulk of the people at large—as shopkeepers, who are an important class in the consideration of this question—do not yet quite understand the difference between measuring and weighing. The matter wants ventilating and discussing.

As to the carrying out of uniformity, Mr. Chaney had previously remarked (Q. 54) that if the legislature required all corn to be sold by weight, local officers, as inspectors of weights and measures, would require to see that the law was carried out properly. With a view of seeing that it was so carried out, they would have to make visits to shops and to farmers' premises, and they would have to take proceedings in any case where corn was not sold by weight, or was sold contrary to the statute. In the Bill which I introduced last session, I suggested a fine as a means of reminding the public of their duties if it is desired to have a uniform weight. This alarmed a few members of the Central Chamber of Agriculture; but I wish to point out that the fine was to be levied on the dealer, not on the farmer, which is the plan adopted with respect to corn returns, any inspector having the power now to take proceedings against any dealer for not making returns. This is occasionally done to remind localities of the law, but I think the knowledge that a fine could be enforced would have strengthened the hands of farmers against those dealers who might confuse them by proposing to buy in different weights or measures to what they have been accustomed, of which a great point was made by the Committee of 1834. All the best dealers now are above taking this advantage, and consider the farmers themselves in backward localities are the chief obstacle to a uniform system, by reason of their inability to calculate in any other standard than the one they have been accustomed to.

Having made inquiries from leading dealers in many parts of the kingdom, I must give them the credit of being generally in favour of a uniform system, though they are supplied with ready reckoners which, with little trouble, help them to calculate from one standard to another. There is no reason, however, why they should not be glad to be saved this unnecessary amount of trouble. In Shropshire, the dealer requires 75 or 72 lb. to the bushel, but when farmers buy grain for seed, they receive only 60 lb. to the bushel. Within fifteen miles of Bridgnorth, a great barley district, part of it known by the name of Wheatland, grain is sold by thirty different weights.

Sir Edward Birkbeck and the inspectors are at issue on the extent to which barley is sold in Norfolk by weight, all agreeing that barley is sold by measure for malting purposes, which does not come within the purview of the Corn Sales Inquiry. This point, however, I may observe, is to be the subject of further official inquiry. Sir Edward asked Mr. Chaney (Q. 71) :—

How can weight be any criterion of value, when barley weighing 56 lb. may be worth only 24s. a quarter, and another sample which weighs but 53 lb. might be worth, for malting purposes, 10s. per quarter more ?

A. Weight alone is not sufficient; both must be taken together; there is always the difficulty of combining a quantitative test with a qualitative test. When we speak of value that is the qualitative test; when we combine weight with measure for ascertaining the price of a bushel, that is the quantitative test; when we speak of weighing corn for sale that is qualitative. A ton of corn is a quantitative expression; but when we speak of a bushel of 60 lbs. of wheat that is a qualitative expression. It is from that confusion of terms that difficulty has arisen in the sale of corn; there is no other commodity in which so much difficulty has arisen. Take the sale of gold, which is rather an extreme case, but still so far an analogous one. Gold is sold by the ounce; a purchaser, if he wishes to know the quality of it, asks whether it is 18-carat gold; but no difficulty has arisen in the case of gold, because there has been no confusion between the quantitative and the qualitative expressions.

Sir Edward asked how the corn inspectors get their information. This comes from the dealers, not the farmers, who have never been induced to take the trouble to give the information. Not one in twenty of the transactions in corn in the smaller markets, or many of the larger, is ever given, as anyone can satisfy himself if he chooses to make the inquiry.

Mr. Farquharson, who has taken a great interest in the tithe question, asked the witness whether an arrangement could not be made to sell by both weight and measure. To which Mr. Chaney replied :—

No arrangement could be suggested which would meet the natural conditions of every county and district throughout the United Kingdom. The natural weight of corn varies in every locality. If we suggested a figure, say 60 lb. to the bushel, we know it could not be followed, as the weight of

corn varies so considerably. We should put many to grave inconvenience if we suggested as a magnitude one fixed weight per bushel. We are not dealing with a thing of a fixed quality which can be dealt with and manipulated as gold is, but we are dealing with a natural thing, and we must take it as we find it, and we cannot fix the weight of that natural thing (Q. 142).

Asked by Mr. Maguire to state the precise difference between measured weight and measure and weight, Mr. Chaney replied:—

Measured weight is where the seller is buying a definite weight per bushel fixed at the time of sale. Buying by measure and weight is where the seller is buying a fixed measure of grain, as 100 quarters, the grain being subsequently delivered by weight; rather the converse of the other operation (Q. 169).

When the question of the proposed standard of uniform weight is under consideration, the cental, and in connection therewith the decimal system generally, naturally present themselves for discussion.

In 1853 a Committee of the House of Commons, of which Mr. Ewart was chairman, met to consider the introduction of the metric system into England, and reported in its favour. Before this system was established in France, at the end of the last century, the French Government proposed to the English to have a joint conference on a uniform system of weights and measures for both countries. This offer, owing to the ill-feeling then existing between the two nations, was unfortunately not acknowledged, but a Committee of the House of Commons sat to consider the question in 1790. The result of a deliberation between authorities of both countries at that time would not only have been of extreme interest, but would possibly have been the means of effecting a uniform system throughout the world. The opportunity, however, was lost. The metric system was adopted in France, and has since been adopted by other foreign Governments. The Select Committee of 1853 was followed by a Royal Commission, whose inquiries extended over several years. The decimal system at that time found its strongest opponent in Lord Overstone, who drew up a series of questions to be answered by the witnesses before the Commission. He attacked the decimal system root and branch, pointing out that 960, the number of farthings in a pound, is divisible by nearly twice as many divisors as 1,000, the numbers being really 27 to 15.

Mr. Lowe attempted without success to advance the decimal system by a motion in the House, and it has since made little progress in England. There is, however, a decimal system association, comprising many leading men, and there have been two International Conferences on the subject, one at Berlin and

the other at Paris, at which Mr. Yates, Mr. Chisholm, and Professor Leone Levi were the chief movers. The Select Committee on Decimal Coinage sat in 1852-3, and the Decimal Coinage Commissioners from 1857 to 1859, when their final report was published, though further Parliamentary papers were published containing correspondence on the subject till 1864. Amongst them is a joint resolution of the Senate and House of Representatives of the United States respecting the appointment of a suitable person to confer with the proper functionaries in Great Britain with a view to the mutual arrangement of the coinage of the two countries, so that their units should be commensurable.

It is certain that whatever may be the merits of the decimal system in facilitating calculations, and doing away with half the rules of arithmetic, it has made very little progress since that time in this country. In 1870, at the request of Professor Leone Levi, the Central Chamber of Agriculture appointed a small committee, of which Mr. Pell, M.P., Mr. Read, M.P., Colonel Tomline, M.P., and myself were members, to confer with a similar committee of the International Decimal Association, comprising Earl Fortescue, Mr. Smith, M.P., Mr. Yates, F.R.S., Mr. D'Eyncourt, Dr. Augustus Voelcker, and Professor Leone Levi. This joint committee presented a lengthy report urging the legalisation of a metric system of weights and measures in this country. At that time, and on more than one subsequent occasion, the Chambers of Agriculture resolved in favour of the adoption of the cental as the standard weight. But the farmers of the Midlands, like the Corn Association of Glasgow, are in favour of the hundredweight. On the cental question, I feel sure the Chambers did not represent the smaller farmers, most of whom have and use the 56 lb. and 28 lb. weights.

In 1882 Mr. Rankin introduced a Bill with the object of making the cental the uniform weight. Mr. Chamberlain, who was then President of the Board of Trade, being interviewed, at the same time, by two large deputations, one in favour of the cental and one equally strong in favour of the hundredweight, requested them to try to agree together before they came to the Government; but he subsequently added the cental to the list of legalised weights in the Act of 1882, which fixed the imperial measured weights for the convenience of other weights for the corn returns. Since that time the cental can hardly be said to have made any appreciable progress beyond Liverpool, where it is used for trade with America, where the ton is a ton of 2,000 lb., and wheat is generally reckoned,

I believe, by the quintal, the quarter of the ton. This, by the way, confirms the remark made by Lord Overstone and his friends in 1857, and repeated by Mr. Chaney in his evidence of 1891, as to the tendency of the human mind to "halving," that is to deal in halves and quarters, so that 3 as the quarter of 12 is preferable to  $2\frac{1}{2}$ , the quarter of 10, which involves a fraction. Lord Overstone made light of the different systems of foreign countries, as these, he said, mainly affect merchants who can easily manage the calculations necessary for international transactions. The statistician had not come to the front so much in that day as since, when it is found utterly impossible for him to compare with any correctness the produce of countries like France, which make their returns in both weight and measure, and others which make returns, some in weight, and others in measure, without saying why they prefer the one system to the other, or letting us know what the measure means; or again, to compare estimates of foreign produce with our own agricultural statistics. In regard to these it may be observed that an estimate of the produce is sent in by English farmers by measure, without any intimation of what that measure means in their locality, whilst the Irish farmers make their returns by the hundredweight, which everyone understands. In regard to cheese, however, the hundredweight aggravatingly appears as 120 lb., the reason being that it is convenient to reckon, because 1d. per lb. makes half a sovereign.

There are two remarks founded on the past experience of those who have strongly advocated the introduction of the decimal system into England which, perhaps, may be introduced here. The one is that those who so strenuously exerted themselves in its favour a generation ago were of opinion, I believe, that it would have been wiser to have made an attempt first to decimalise the weights rather than the coinage of the country, though from the unanimous opposition I have found to the cental at Mark Lane, and the little progress this weight has made beyond Liverpool, even in Lancashire, I do not think much success would have been achieved with the English corn trade. The second most obvious remark is that the French nomenclature of the metric system would never be tolerated in this country except amongst statisticians and other scientific men. To convince ourselves on this point we have only to consider what would be the effect of our going to a country market and asking for a kilogramme, or a half kilo, the half being the most usual form in which the decimal system is used in business. I draw attention to these points because it is important that there should be no conflict again between the supporters of the

decimal system and the hundredweight. To avoid this, the Corn Sales Committee of the Central Chamber of Agriculture have suggested for consideration whether uniformity might not be attempted first through the hundredweight, as being the weight more familiar to farmers, and then, conceding, as the Glasgow Corn Association suggested, that the decimal system may be theoretically the best, look forward to taking the second step when education has advanced sufficiently for the English nation to be convinced, which they are not at present, that the time is ripe for a further change.

We have to consider what the hundredweight has to recommend its adoption beyond the fact that it, or the half hundredweight, is found in most farmers' houses. Why did our forefathers use a hundredweight of 112 lb., instead of 100 lb., as a new country probably would? The answer is that the oldest weight was the stone of 14 lb., and the 112 lb. is a multiple of 14. It is a great argument in favour of the more general use of the hundredweight that imported grain is reckoned by the hundredweight by the Board of Trade, though translated as well into equivalent quarters, which are placed side by side with the hundredweights in the official publications. Major Craigie informs me that the register duty on wheat taken off by Mr. Lowe, which produced a million and a half of revenue, was a duty of 3*d.* a hundredweight, not 1*s.* a quarter, as often stated.

The Committee of 1834 stated fully the importance to the community of correct and intelligible quotations of corn, on which point all agriculturists are probably agreed. It reported in favour of legislative interference to effect this. In 1881 we have seen the competition was between two weights, the cental and the hundredweight. The advocates of measure, or of weight and measure, or of measured weight, put in no appearance on the occasion of the two rival deputations to Mr. Chamberlain. The unknown problem to men in the Midlands seems to be the extent to which any of these principles are and will be supported in the Eastern counties.

I believe the merchants and corn dealers in Norfolk prefer buying barley by weight, but that the sellers prefer selling malting barley by measure, because it is often light. The dealer often decides whether it is to be sold by weight or measure, as suits him. This view in favour of measure may be more or less common to five Eastern counties, but it is restricted to only the one cereal, barley. As to the amount of error to which measure and weight are respectively liable, it may be taken from experiments recently made at the Standards Office that the maximum probable error of measure-



ment, without resorting to fraudulent practices, is 16 per cent. The maximum probable error of weighing, without resorting to fraudulent practices, is 6 per cent.

One point of difficulty in making a weight uniform was suggested to be the need which would arise for farmers to obtain new sacks. This, Mr. Chaney thought, would be a transitory difficulty, and I have since ascertained from Mr. Wadham, of the Great Eastern Company's goods office, that they supply the sacks to the Eastern counties farmers, for which the charge is 1*d.* a sack for one journey. If kept for a certain number of days they charge 1*d.* a quarter, and  $\frac{1}{2}$ *d.* per sack per week as long as the grain remains with them. Not one in a hundred Eastern counties farmers are said to use their own sacks. They can apply to a country station for any quantity.

Formerly wheat was carried at five quarters to the ton irrespective of weight; barley six quarters, oats seven, malt  $7\frac{1}{2}$ , beans and peas five. The result of this plan was that the company usually lost a sack (or a coomb) in wheat and in beans and peas, and about a sack in malt. The fact, no doubt, is that in some Eastern counties barley is sold by measure only, but it is equally true that some is sold by weight. On this point, no doubt, we shall hear much more, but it must be remembered that the bears and bulls of the corn trade are very capable of writing newspaper paragraphs to influence farmers and the trade.

My object in writing this article has been to remind those who have expressed themselves in favour of a uniform weight for grain, and have taken some steps in trying to secure it, that an opportunity is at the present time afforded for making another attempt to settle this controverted question. If agriculturists generally will be good enough to afford their consideration to the inquiry commenced last session by a Committee of the House, which I hope will be reappointed early next session, and if farmers will deal with the question unitedly, there is a fair likelihood of its settlement.

R. JASPER MORE.

---

## ABORTION IN CATTLE.

ABORTION is the premature expulsion of the impregnated ovum, the embryo, or the fœtus before viability, by which is understood the power to live when separated from the mother. After viability, the untimely expulsion of the fœtus is described as pre-

mature birth. The period of viability, as compared with the time of gestation, varies considerably in different animals, and can hardly be ascertained with positive accuracy; but the following statements have been made in regard to this part of the subject:—

Animal	Period of gestation	Viability at
Foal . . . . .	11-12 months	10 months
Calf . . . . .	9-10 "	7 "
Lamb and kid . . . . .	5 "	4 "
Pig . . . . .	4 "	3 "
Puppy . . . . .	9 weeks	7 weeks
Kitten . . . . .	55 days	45 days
Rabbit . . . . .	25 "	20 "

Abortion has attracted the attention of stock-owners and veterinary surgeons as far back as agricultural and veterinary records extend—unread and unregarded records, it would seem, but which may with advantage be put before the readers of the *Journal* in a concrete form.

First, it is important to note that the subject of abortion is connected with the larger subject of embryology. Expulsion of a mature ovum occurs at every period of œstrum. This minute organ escapes from the ovaries into the Fallopian tubes, and through them into the cavity of the uterus. Not meeting, in its course, with the sperm-cell of the male, the dormant life is not aroused into action, and the useless egg is cast forth as a waste product along with the débris of the mucous membrane. Impregnation of the ovum checks its course, developmental changes at once begin, the embryo advances to the foetal state, and at a certain moment the uterus begins to contract, and the young animal is forced into the outer world. It is not known what changes suddenly occur to cause the expulsion of the foetus, nor why the period of parturition differs so widely in animals of different species or families. If the exact cause were known, it would perhaps be easy to solve the mystery of premature expulsion of the germ.

Investigations into the nature and causes of abortion, which have been carried on for the last century by veterinarians over a large portion of the civilised world, bring one fact out prominently—viz., that abortion is a product of civilisation. Wild races, so far as can be ascertained, enjoy an immunity from the disease in the epizootic form. As the result of common causes, *i.e.*, violence, acute disease, exertion, excitement, or fear, abortion may be classed with other accidents to which animals are liable under all conditions of existence.

Epizootic abortion has steadily increased among our cultivated breeds of cattle. Cows of the highest type of artificial excellence are most likely to suffer, for two reasons:—

- (a) Want of constitutional tone and power to resist disease due to precocity of development.
- (b) The use for breeding of pedigree cows, which repeatedly fail to hold to their service.

On the first point, the writer may quote from an essay which he wrote for the Bath and West of England Society's Journal in 1864<sup>1</sup>:—

Were animals bred and treated with more regard to a healthy condition of the various organs, their liability to disease would be materially diminished and their power to resist it augmented, and the extraordinary losses which are sustained every year in our country would no longer be a reflection upon our agriculture. The readiness with which animals yield to the influence of epizootic maladies has long been a subject of remark, and we do not underrate the virulence of the disease nor the importance of any means which shall tend to prevent its importation when we insist that a great part of the mortality is due to the predisposition of the animal's system permanently established by our methods of breeding and management.

We are ready to admit that remarkable results have followed the efforts to improve the breeds of stock, results not satisfactory in the main, but not the less decided. We accept the proofs of what can be achieved by systematic attention to a definite object; but we do not the less contend that the system has been carried too far. The principle has been all along that of the railroad: the struggle to drive onward rapidly at all risks, even without considering them. The cry has been for the animal that will be the first ready for the carriage, the saddle, the dairy, or the butcher, and so far the demand has been answered; at what cost we have endeavoured to show. Whatever respect may be accorded to our suggestions, we may at least ask that the "forcing system" shall no longer exist under a false designation, that men shall not in future speak of the artificial induction of disease, of premature development, and of systematic degeneration under the imposing terms CULTIVATION AND IMPROVEMENT.

Those words were written some twenty-seven years ago, and they are repeated now by the writer with as firm a belief in their truth as when he penned them in the first instance. Again, the following passage is quoted from a small work which was written in 1885, entitled *Animal Life on the Farm*,<sup>2</sup> in which, in a very concise manner, the history of breeding and rearing of stock of the highest type, under our present system of cultivation, is given:—

Our "bird's-eye" view of animal life under two very different sets of con-

<sup>1</sup> *Precocity of Development considered in Relation to the Results of the Present System of Breeding and Feeding.* B. & W. Journal. Vol. XII. 1864, pp. 56-58.

<sup>2</sup> *Morton's Handbook of the Farm Series, "Animal Life on the Farm,"* pp. 100, 101, and 102.

ditions forced us to accept the fact that in Nature everything tends to the benefit of the strong and the extinction of the weak. The sentence is, Fall out of "correspondence with your environment," and die; "if life is worth having, fight for it." The outcome of this stern system is perfection of organisation and perfect life. On the other side of the picture we saw the animal under the ban of civilisation, having nothing to fight about—no life worth speaking of to struggle for; compelled to take the food provided for it, with as much fresh air as might be thought good for it; "cabined, cribbed, confined"—a meat-making and manure-forming machine; "a tub with a hole in the bottom" (these are the very words of a practical breeder and feeder of stock)—"a tub with a hole in the bottom," which must be filled up by pouring into it quickly, because "the quicker you pour in, the less the waste."

As to the results of this system, the words of a well-known stock-breeder, referring to what he called "baby beef," may be quoted with the account of the butcher who slaughtered the animals themselves:—

Remarkably ripe, handsome carcasses of beef from bullocks under twenty months old; lamb sold as mutton at seven and ten months old, of which the butcher writes: "Never, during my experience of over forty years, have I had any sheep equal to them in weight, quality, and flesh at their age."

Another quotation from *Animal Life on the Farm* may be given in illustration of the effects of breeding from animals so reared:—

Scientists are well aware that the most certain way to secure the development of any artificial instinct or quality is to breed from parents in which the instinct or quality is apparent. "Like produces like" is the practical breeder's sure maxim. Professor Huxley, on the side of science, expands the maxim in these words, to which we shall have to refer more than once before we finish the subject: "The one end to which, in all living beings, the formative impulse is tending—the one scheme which the Archæus of the old speculators strives to carry out—seems to be to mould the offspring into the likeness of the parent. It is the first great law of reproduction that the offspring tends to resemble its parent or parents more than anything else"—i.e. resemble them in structure and functions—in good or bad qualities—in excellences or defects. And, with the meaning fully grasped, this sentence is an epitome of the science and art of breeding.

In regard to the second point, the cow which does not hold to service is an animal in which the recurrence of œstrum is accepted as proof that impregnation has not taken place. It is at least very doubtful if this view is the correct one. The bull is known perhaps as a sure stock-getter; in which case is it not fair to suspect that the service has been effective each time, and that the impregnated ovum has been prematurely expelled (aborted), and that the cow has the susceptibility which leads to abortion, and will transmit that tendency to her offspring, if at length she becomes pregnant and brings forth a living calf?

Passing on to the consideration of the evidence which veterinary authorities have collected on the subject of abortion,

one of the earliest writers (1786) on cattle, Clater, may be referred to. This author writes in very general terms. He speaks of abortion as one of the curses of the breeder, refers to some of the common causes, and speaks also of the epizootic character which the disease sometimes assumes. Even at that early period, it was clearly recognised that the affection did present the character of a contagious malady.

Youatt, in 1834, enters into details; he refers to the susceptibility of cows above that of other animals of the farm. After speaking of the common causes of sporadic abortion, accidents, climatic changes, certain kinds of food, violence, and excitement, he gives the history of a remarkable case which he quotes from the French veterinarian Chabert. A farmer at Toury, in France, had abortion among his cows for thirty years, before it came under the notice of this expert. On inquiry into the history of this case, it appeared that, thirty years before, the farmer had purchased a cow from a distant part. The animal, on being brought into his herd, aborted, and other animals followed. Subsequently he lost a considerable number of calves in this way. From time to time he had animals removed, and filled up their places with fresh stock. Still, every year a certain proportion of the in-calf cows aborted, and this continued during the whole period of the thirty years which intervened between the purchase of the cow and the attendance of the veterinary expert Chabert. The advice given was to get rid of the whole of the stock, and start afresh. The farmer saw the reasonableness of this suggestion, adopted it, and abortion entirely ceased. This case was quoted in 1834, and it brings us very close indeed to the results of the researches which have taken place within the last few years.

Reference must next be made to a paper in this Society's Journal for 1851, written by Mr. Barlow.<sup>1</sup> This gentleman was at the time a demonstrator of anatomy in the Edinburgh Veterinary College, and there is no doubt that his untimely death about 1855 robbed the veterinary profession of a very distinguished ornament, and one of the most rising men of the time. He gives an account of certain cases which came under his notice, and writes a very able description of the causes, symptoms, and methods of prevention. He starts with this statement:—

From various inquiries which have been made, and from the statements of travellers and other persons competent to speak on the subject, it seems that among the vast herds of wild cattle inhabiting large tracts of country on the continents of the Old and New World abortion is unknown.

<sup>1</sup> R.A.S.E. Journal, Vol. XII., Part I, 1st Series, 1851, pp. 64, 72.

As to the symptoms of abortion, Mr. Barlow remarks that in many cases there are no warning symptoms. A little mass of decomposed matter is found in the shed or field, and it is known that the cow has slipped her calf. In certain instances, however, there are premonitory signs, which bear a distinct resemblance to those which occur in ordinary parturition, in the swelling of the external parts and indications of activity in the udder, and a glairy discharge from the generative organs.

Before every act of abortion, and at whatever period it occurs, except perhaps before the third or fourth week of gestation, there is a discharge of brown glairy fluid and mucus from the organs of generation.

This discharge has been made the subject of experimental inquiry, and the conclusion is becoming firmly established that in that discharge is contained the virus which is concerned in the propagation of the disease.

M. Bouley, for many years the Director-General of the veterinary schools in France, was a most distinguished scientific observer, and in his *Dictionary of Veterinary Medicine*, published in 1863—*i.e.*, twelve years after Mr. Barlow wrote his paper—he refers to the fact of abortion beginning with the introduction of a new cow—a very significant statement. He notes, in the course of his description, all the various common causes which give rise to abortion, and among these causes he speaks of imitation, which is a characteristic term based on a recognition of the fact that when abortion takes place in a herd, the cows all round will become extremely excited, will rush to the spot where the foetus and membranes are lying, will sniff at them, and will rush away again in a frantic state. It is a matter of positive certainty that after this performance on their part a considerable number of them will abort.

M. Bouley names the other causes as mechanical, various kinds of food, the use of powerful medicines, fear, and constitutional tendency. For the term constitutional tendency, "hereditary" would be the modern equivalent.

From M. Bouley we may pass on to Dr. George Fleming, who in 1878 published a very valuable work on veterinary obstetrics, which included all that had been written and doubtless all that was known on the subject up to that date.

Dr. Fleming quotes from Continental experts their different views as to the causes of epizootic abortion, and points out that some of them refer it to the action of particular plants. Thus, they consider that rue, rye, savin, and ergoted grasses are commonly concerned in the production of abortion on a sufficiently large scale to merit the title of epizootic. Dr. Fleming

urther quotes Zundel to the effect that if septic bacteria are introduced into the vagina abortion follows. This statement is worthy of careful thought; because it is the first suggestion met with that the introduction of morbid material will induce the contraction of the uterus and probably cause the death of the foetus by blood-poisoning as a consequence of this kind of inoculation. Dr. Fleming, at the conclusion of his article, offers the suggestion that abortion is probably dependent on a specific virus.

It remained for another writer, M. Nocard, ten years later, to assert a positive opinion that this was the cause, and he added to that assertion a statement that he had discovered the virus on which the occurrence of this malady in the epizootic form depends.

The next author is Professor Axe, who, in 1885, wrote a pamphlet on the subject of abortion, giving a history of cases which had come under his own observation, and referring to the theory of contagion, which, however, Professor Axe looks upon as insufficiently sustained by the evidence. Although he does not deny that abortion may be contagious, his opinion on the point is expressed in the following quotation<sup>1</sup>:—

Of abortion it may be said (1) that it is not known to be identified with matter possessing contagious properties; (2) that it has no fixed period of incubation; (3) that, except in occasional instances, it is unattended with fever; (4) that one attack predisposes to a second, and is usually followed by several in succession.

These are qualities which do not belong to contagious diseases in general, and the question is still left open as to the disease arising from the action of either septic organisms or organisms possessing special pathogenic properties.

In this Society's Journal for 1885,<sup>2</sup> there is an account by the same author of an extensive outbreak of abortion amongst pregnant ewes in Lincolnshire. It seems that, in the course of his inquiry, Professor Axe examined 106 flocks, containing a total of 51,475 ewes. Among all these flocks abortion had been going on for some time. He describes the method of feeding which had been adopted, and says that the use of food such as turnips or other roots in an unripe and watery condition would be calculated to damage the system, and predispose the animals to suffer from any existing causes. He sums up in the following words:—

*First and foremost [as a cause of the disease] stands the mischievous and*

<sup>1</sup> *Abortion in Cows: its Causes, Prevention, and Treatment.* By J. Wortley Axe. Page 31. (A. Napier, Seymour Street, Euston Square, N.W.)

<sup>2</sup> R.A.S.E. Journal, Vol. XXI., Pt. I., 2nd Series (1885), p. 206.

fatal practice of feeding pregnant ewes exclusively on unripe watery roots, and especially on unwholesome filth-laden shells. *Secondly*, pain and suffering caused by protracted "foot-rot." *Thirdly*, exposure to cold winds and heavy continuous rains. *Fourthly*, fatigue arising out of the deep and sticky state of the ground.

On the subject of sporadic abortion, a paper in the *Journal*<sup>1</sup> by Mr. Clement Stephenson, of Newcastle, a gentleman not only distinguished as a breeder of cattle, but as an eminent veterinary surgeon, whose observations are certainly deserving of the greatest respect, may be read with advantage. He treats the subject of common causes, but speaks of sympathy as one influence likely to cause an extension of the malady to a herd, and he touches the question of ergoted grasses. He says, however, that he has no personal experience in the matter, but he thinks it quite reasonable, knowing the action of ergot on the uterus at the time of parturition, to suspect at any rate that it may have some influence in causing contraction of the uterus at a period when the fœtus is not sufficiently developed to be capable of living apart from its mother. But he does not pay any attention to the contagion theory—in fact, at that time it had not assumed such prominence in the public mind as it has recently.

Following Mr. Stephenson in the *Journal* we have a medical man, Mr. Johnson, of Kirkby Overblow, in Yorkshire, who adopted the theory of ergot as the cause of abortion. Mr. Johnson's view appears to be that the disease is decidedly the consequence of consumption of ergoted grasses in the majority of instances. One important remark he makes, viz.<sup>2</sup>:—

So universal is the belief in its infective properties that, where I know the malady exists, or has been recently present, I have frequently had to use all my persuasive powers to assure such owners that "I am not a sort of detective sent by Government to prevent them spreading the disease by sending their produce to market" before I can get any information on the subject.

That is important testimony to the view held by agriculturists that the affection is most distinctly a contagious malady, and that view has now been sanctioned by the highest veterinary authorities.

There is no doubt that the popular idea of the effect of ergoted grasses on the in-calf cow is based on the fact of its influence at the time of parturition. No evidence, however, has been advanced to prove that its action is manifested before that time, and experiments which have been made by

<sup>1</sup> R.A.S.E. *Journal*, Vol. XXI., Pt. II., 2nd Series, 1885, p. 499.

<sup>2</sup> R.A.S.E. *Journal*, Vol. XXII., Pt. II., 2nd Series, 1886, pp. 462, 463.



feeding in-calf heifers on ergot have generally failed. At the Royal Veterinary College seven in-calf heifers were fed on grass in which ergot was abundant, and when the supply failed ergot was mixed with their food, but no effect was produced. Very serious consequences have followed the consumption of rye-bread contaminated with ergot, and numerous persons have been fatally poisoned, but abortion was not among the characteristic signs of ergotism in the human being. Among cattle, severe outbreaks of ergotism in Kansas occurred some years ago, and great fatality was occasioned, but cases of abortion were extremely rare. Extensive outbreaks of abortion have occurred among cattle at a season of the year when ergot does not exist, and the worst that can be urged against ergoted fodder is that it may occasionally act as an irritant poison and cause abortion in the same way as other accidental causes may induce it from time to time.

Next there is a very valuable paper by M. Nocard, whose reputation is in itself a sufficient guarantee of the importance of his observations. He was employed by the French Government to make an inquiry respecting abortion which had prevailed amongst the Nivernais breed for many years. Indeed, at the time that M. Nocard commenced the inquiry, it was thought that the whole breed would be extinguished.

Different views were held with regard to the disease among the cows. Some experts decided that it was dependent upon crossing with the Durham (or Shorthorn) breed, others that it was due to the remarkable precocity of development of this animal and its tendency to lay on fat, and it was also referred by a number of veterinary surgeons to ergoted grasses. M. Nocard deals with all these suggestions, and produces evidence to show that they are entirely insufficient to explain the occurrence of the disease.

In regard to the presence of abortion in a herd, M. Nocard evidently agrees with M. Bouley when he says that, as a general rule, abortion appears as the ordinary result of the introduction of a pregnant cow newly bought. If this cow aborts, some of the other cows in the shed are certain to follow the example. He does not say at what distance of time, but he states as a well-known fact that one case is followed by another. He refers further on to those cases in which abortion occurs after such a late period that the foetus survives for a few days, and on this point he makes a most important remark:—

As to the calf that has aborted, it is generally dead at the moment of abortion. Sometimes, however, it happens that the animals are expelled alive, perfectly well formed and vigorous to all appearance. Nevertheless, in four

cases out of five, the first, second, or third day after birth they begin to bellow in a peculiar manner. They cease to suck, are attacked with diarrhoea, and succumb in a few days, sometimes in a few hours. This peculiar bellowing seems to be a sure prognostic of the death of the aborted calf.<sup>1</sup>

M. Nocard remarks that in cases where calves have been born before the proper time, it has been noticed repeatedly that the animals suffer as soon as they are born from diarrhoea, and are generally dead within twenty-four hours. Those which live over the two days always get on perfectly well afterwards. He then goes on to refer to his researches with the idea in his mind that the disease is distinctly contagious; and he says, among the aborted cows, even those which are pregnant for the first time, there exist, in the cavity of the uterus behind the mucous membrane and the membranes of the fœtus, and notably in the crypts of the cotyledons, various micro-organisms which are not found among pregnant cows that have come from a country where abortion does not exist. His reference to these micro-organisms does not include anything relating to their morphology, but he says that they do not appear to exercise any injurious action on the mucous membrane of the mother either during the period of gestation, which is suddenly interrupted by the process of abortion, or after abortion. The conclusion at which he has arrived is that the disease results from the action of a specific microbe contained in the uterine membrane, in the intestines of the fœtus, and in the discharges which take place from the vagina. He goes on to say that, before this proposition can acquire an absolutely affirmative character, it is necessary that he should be able to produce the malady in healthy cows by the inoculation of the pure culture of the organisms, *i.e.*, by one or other of the microbes which he had isolated, and, further, he adds that these experiments, being indispensable for the definite solution of the question, are in course of being carried on.

M. Nocard gives in his paper an account of his means of prevention. He says that every week the floor of the cow-stall should be swept and cleansed, and watered with a solution of sulphate of copper, of about 1 ounce to a pint of water (40 grammes to the litre). He formerly injected antiseptics into the vagina, but he has given up this practice as useless. Every morning care should be taken to wash with a sponge saturated with the following solution, the vulva, the anus, and the under surface of the tail of all the pregnant cows:—

---

<sup>1</sup> *Bulletin, Ministère de l'Agriculture, Paris, N° 8, Décembre, 1886, p. 949*

Distilled water . . . . .	20 litres, or about 20 pints
Glycerine . . . . .	} 100 grammes, ,, 3 ounces
Alcohol (of the specific gravity of 36)° . . . . .	
Bichloride of mercury . . . . .	10 grammes, ,, 2½ drachms

Finally, he says that, in the case of an aborting cow, it is necessary to isolate her immediately, and to deliver her at once with the hand, destroying by fire or by boiling-water the foetus which is delivered.

In reference to his latest method, which is the result of further experience, M. Nocard observes:—

I have considerably simplified my methods. I have completely suppressed the vaginal and uterine injections, which provoke expulsive efforts. My experience, already great, has taught me that a beast which has once aborted will abort again or remain sterile. The best course is to isolate the animal immediately after the abortion, and to fatten her for the butcher. The practical prophylaxis is reduced to a very simple method:—

1. The weekly disinfection of the cow-stall and drains behind the cows with a solution of sulphate of copper, phenic acid,—*i.e.*, carbolic acid, or corrosive sublimate.

2. A daily washing, by means of a sponge saturated with the solution of corrosive sublimate of the anus, the vulva, the perinæum, and the tail. The prescription used for this purpose is as follows:—

Rain water . . . . .	10 litres, or about 10 pints
Corrosive sublimate . . . . .	10 grammes, ,, 2½ drachms
Hydrochloric acid . . . . .	½ décilitre, ,, 1½ ounce.

His final remarks are—

As you will perceive, the procedure is very simple. It only requires care, exactitude, and perseverance. In reality it is useless to hope to see abortion cease immediately. During the first year it will be less serious; but it will show itself still, for all cows which are infected at the moment when the treatment is commenced will abort, almost as a certainty. But all will cease as by enchantment from the second year, for this treatment exactly followed prevents all new infection. The whole thing is essentially an affair of patience.

This is the statement of a practical man; so that there is a method, it seems, by which it is possible to check the progress of the malady, even in its worst epizootic form, by proper disinfection of a simple kind, not demanding any great trouble or scientific skill.

The latest authorities are Dr. Sims Woodhead, Professor Macfadyean, and Dr. A. P. Aitken, who conducted an inquiry in Edinburgh in 1887. They commenced by sending out a number of questions for the purpose of obtaining information as to the general treatment of the cows in which abortion was going on; and they reported that—

The inquiry has proved that the disease is prevalent throughout the length and breadth of Scotland, and there appears to be a general opinion that it is yearly becoming more common. However that may be, it is certain that a great annual loss to cattle-breeders must now be laid to the score of this disease. The inquiry has further shown that no breed can be said to have any special susceptibility to or exemption from abortion. We have learnt of serious outbreaks among Shorthorns, Galloways, Ayrshires, Polled Angus, and Kyles.<sup>1</sup>

The final results of the inquiry were not published until 1889, and the report includes a number of experiments on pregnant cows, and gives us some information in regard to the organism.<sup>2</sup>

*Experiment I.*—A cow that had aborted a few days previously, and which belonged to a herd in which several other animals had aborted during the same season, was brought to the Veterinary College, and placed in a loose box along with a pregnant cow. The two cows were kept together for one month, but the result of the experiment was entirely negative.

*Experiment II.*—A pregnant cow, purchased from a stock in which no cases of abortion had recently occurred, was introduced into a byre in which a large number of cows had recently aborted. With the object of hastening and insuring infection (assuming the disease to be of an infectious nature), a plug of cotton-wool was inserted into the vagina of one of the recently aborted cows, and left there for twenty minutes, after which it was withdrawn, and inserted into the vagina of the experimental cow, and left there for some hours. On the following day the proceeding was repeated. Within one month from the date of introduction this cow began to show the premonitory indication of impending abortion, but the act did not occur until seventy days had elapsed, at which time nearly two of the normal nine months of pregnancy had still to run. The calf was alive when expelled, but it survived for only a short time. As is not uncommon in cases of abortion, as ordinarily observed, the placenta was in this instance retained.

*Experiment III.*—A cow, about six months pregnant, was introduced into a byre in which a number of cows had recently aborted, and placed in a stall immediately adjoining those in which the recently aborted animals stood. In this case also the cow had been purchased from a stock free from abortion. In this experiment, instead of simply inserting a contaminated cotton-wool plug into the vagina, a quantity of vaginal discharge from a recently aborted cow was subcutaneously injected into the experimental animal, the point of operation being the skin of the vulva. The material taken for inoculation was mixed with sterilised distilled water, and it was injected with a sterilised syringe. This cow calved one month prematurely, and the calf, although it survived, was very puny and unthriving; the placenta was retained.

*Experiment IV.*—A cow purchased from a stock free from abortion was placed in a stall adjoining recently aborted cows in the byre in which the preceding two experiments were carried out. This experiment, like Experi-

<sup>1</sup> *Transactions, Highland and Agricultural Society of Scotland, Vol. XIX., 1887, p. 315.*

<sup>2</sup> *Transactions, Highland and Agricultural Society of Scotland, Vol. I., 5th Series, 1889, p. 270.*

ment I., was designed to test the effect of simple cohabitation, and therefore neither inoculation nor the introduction of vaginal discharge by means of a cotton-wool plug was practised. The result in this case was negative, the cow calving at full term at the end of three months.

*Experiment V.*—Two Cheviot ewes, about two months off the time of lambing, were inoculated in precisely the same manner as the cow of Experiment III. Thirty-eight days afterwards one of the ewes lambled a dead lamb, and a day later the other ewe lambled a living but weakly lamb.

It ought to be mentioned that in this experiment a ewe that had aborted on an adjoining farm was placed during the last fortnight along with the two experimental ewes.

*Experiment VI.*—Cotton-wool plugs, previously inserted in the vagina of a cow recently aborted, were introduced into the genital passages of two black-faced ewes, and left there for some time, and subsequently the same procedure was repeated with a plug withdrawn from the vagina of an aborted ewe. Thirty days after the first introduction of the cotton-wool plug one of the ewes aborted, the lamb being dead and about one month before its proper time. The other ewe carried her lamb to full term.

In regard to the organisms, it appears that there were five distinct forms, viz.:—

1. Diplo-cocci occurring in threes and fours and even in short chains, each half of the dumb-bell being from half as large again to twice as large as the micrococcus of erysipelas.

2. The organism was very like the coccus which Dr. Klein calls the *Streptococcus* of scarlatina.

3. The organism was a bacillus nearly as broad as the *Bacillus anthracis*, and four or five times as long as broad.

4. The organism was a long, thin bacillus, very like that of the *Bacillus subtilis*, or hay bacillus; but it was considerably smaller than that organism, and along with it there was no liquefaction.

5. In some of the earlier tubes there was found a short, thick bacillus, but this organism was lost in the subsequent process of separation.

The plan which these experienced gentlemen recommend for preventing abortion is practically the system adopted by M. Nocard—*i.e.*, rain-water containing common salt and bichloride of mercury in solution. They, however, advise injection into the uterus and vagina; whereas M. Nocard has decided that this system is no longer desirable, and has abandoned it in favour of the more simple plan to which I have referred.

In regard to further observations on the subject of abortion, the inquiry should apparently take the direction of experiments on cows and ewes (the latter being less subject to the disease than the former), for the purpose of ascertaining whether or not these five organisms, or any of them which have been separated from the vaginal discharge, are capable of producing the disease. It should also be a matter of inquiry as to the occurrence of abortion among cows which do not hold to the service of the bull on several successive occasions. And, in all parts of the country where abortion exists in the epizootic form, it is most

desirable that veterinary surgeons should adopt with scrupulous accuracy M. Nocard's antiseptic treatment, and report the results. It will be the important duty of the Royal Agricultural Society to publish the results of these observations, and to advise that farmers in all parts, where herds suffer from epizootic abortion, shall at once place their animals under veterinary treatment, which there is now good reason to believe will be attended with success, only, however, as M. Nocard suggests, as the reward of perseverance.

#### SUMMARY.

Cows which are bred and fed under highly artificial conditions are more predisposed to suffer from abortion than those which live under natural surroundings. Epizootic abortion is contagious, and should be dealt with by isolation of the diseased animals, and the regular use of disinfectants to the cows and also to the sheds or stables in which they are kept. On farms where abortion has been a frequent or constant occurrence for some time, the disinfection recommended by M. Nocard should be carefully and regularly adopted and continued for at least two years. When a new outbreak occurs, *i.e.*, in sheds which have been free from the disease for some time, and especially when a newly purchased cow is attacked, the animal should be at once removed, and the system of disinfection recommended should be at once commenced, and continued until all the cows have calved. A bull which has served a cow soon after abortion is likely to communicate the disease for some time to other cows. Finally, it is necessary to remind the stockowner that the plague of abortion is not likely to be completely extirpated unless the preventive measures are steadily and accurately applied as directed.

G. T. BROWN.

---

---

## THE FUTURE OF AGRICULTURAL COMPETITION.

It has required all the courage derived from firm convictions, based upon a great body of evidence, to enable any writer to maintain, throughout the recent period of low prices and generally increasing agricultural imports, that the intensity of agricultural competition was likely to abate in the near future. Circumstances have combined to encourage the unreasonable attitude of the great majority of critics upon this subject, so

that when it was pointed out to them that our superabundant imports were supplied to a great extent at a loss to the contributors, it seemed a sufficient answer to exclaim—"But still they come!" Under such circumstances, it was of no avail to insist that there was no more certain axiom in business affairs than that which affirms that, in the long run, production at a loss cannot be kept up. The reply was that the foreign and colonial competitors of the British farmer, with vast areas of land under cultivation, must go on producing the staple commodities at any price which they could obtain. Moreover, the most ridiculous estimates of the cost of production in foreign countries and British Colonies were put forth and generally accepted, while the ruin of those interested in "mammoth" farms and ranch companies attracted but little attention. It happened, too, that the strain upon our foreign competitors, when at its worst, was alleviated by favourable seasons, by a great reduction of freights, by vast sums of money obtained from gullible British capitalists, and by the fall in the gold value of silver. These and other circumstances of less importance explain why it was that some of the competitors of the British farmer, though suffering quite as severely as he, were able to keep up their supplies to our markets in undiminished or increasing volume up to the end of 1890. But now there is reason to believe that the tide of battle has turned, not only for a single year, but for some years to come, if not permanently. It will be seasonable, therefore, to present some of the facts and arguments in support of this belief, in the hope that there is now a better chance than there has been previously of their receiving calm and thoughtful attention. In order to explain the reasons for a hopeful view of the future, however, it is necessary to point out the causes of the excessive competition from which British agriculturists are still suffering.

By common consent the competition in *wheat* production has been regarded as the most severe and important. A large proportion of the most productive land in this country is better suited to the growth of wheat than to that of any other crop, and a great deal of it has been thrown out of cultivation, or reduced in value by thirty to seventy-five per cent., in consequence of the greatly reduced value of wheat in recent years. Even on mixed soils which grow other cereals at least as well as wheat, or do well when laid down in pasture, the wheat crop is a very useful one in a rotation, and, if for its straw alone, its growth must be kept up to some extent so long as it can be without absolute loss. Besides, the prices of all cereals are affected materially by those of wheat, and there is no doubt that a

restoration of moderately high prices for that grain would do more for British agriculture than any other change in values.

It was not until after 1874 that the average price of wheat fell permanently below fifty shillings a quarter, except for one year, 1877, in which it was fifty-six shillings and ninepence; and it was not till after 1874 that the wheat acreage of the United Kingdom began to decrease. In that year it was 3,830,767 acres, a total only slightly exceeded in any year later than 1860, and not greatly before that date, so far as estimates can be relied on. Previous to 1874 our net imports of wheat, including flour, had only once been up to 12,000,000 qrs.; but since that year they have increased, with fluctuations, as the wheat area has declined and the population has advanced, until they now range from about 19,000,000 to 20,000,000 qrs. The fall in the wheat area of the United Kingdom, partly cause and partly effect of the increased foreign supplies, is 1,438,522 acres, the crop of 1891 having covered only 2,392,245 acres. But in 1880 the average price of wheat was still over forty-four shillings a quarter, and the area of the crop in the United Kingdom was 3,065,895 acres, while in the United States, Canada, and Australasia the acreage had not begun to decline. It was in the natural order of things that British growers, with their heavy expenses, should be the first to suffer from the fall in prices. The strain upon them was more severe at about that time than it had been before, or has been since, for rents had reached their maximum in 1879, after which they rapidly declined, while other expenses also have been greatly reduced. But in the United States the price of wheat on the farm had not regularly fallen below a dollar a bushel. It was nearly eleven cents over the dollar in 1879, only five cents below in 1880, and more than nineteen cents above in 1881. Consequently, the area of the wheat crop was nearly 38,000,000 acres in 1880, the maximum up to that period, and an acreage only twice reached in subsequent years before 1891. For all Australasia, too, the area in 1880 was 3,379,239 acres, which showed a considerable increase over the total of any preceding year. The total for Canada in 1880 is not available; but in 1881 it was 2,342,355 acres, which appears to have been the greatest acreage grown in the Dominion in any year previous to 1890, as a considerable decline took place for some years, only covered by the recent increase in Manitoba and the North-west, if at all. In India and South America, too, there had been increases in the wheat acreage, as well as in Europe as a whole, and in some of the minor sources of supply.

There is no doubt that, in the ten years ending with 1880, the growth of wheat in the world had extended much out of proportion to the increase of population. In the United States





The year 1870 was before the days of agricultural statistics for India. In 1879 the area of the wheat crop in that country was 25,812,407 acres, and in 1890 it was 24,938,100 acres, showing a reduction of 874,307 acres. This, with probable decreases in some European countries for which there are no statistics, and in Egypt, may be set against increases in the Argentine Republic and probable increases in the Danubian countries, Asia Minor, and Persia. It is possible that there has been an increase in Russia since 1883-7; but there are no figures for later years. Spain had 7,311,892 acres in 1857, but probably has a smaller area under wheat now. Egypt, in 1871, had 1,103,124 acres; but as her exports to Europe have fallen off greatly in recent years, it is to be assumed that the acreage has been reduced. I am indebted to Major Craigie for the Austrian and Hungarian figures for 1890, and the Italian figures for 1891; but he informs me that those for other countries which I lack are not to be obtained. It is probable that in estimating the Canadian area for 1890 for other provinces besides Ontario and Manitoba (the figures for which are official) too little has been allowed for the decline of wheat-growing in Quebec and the Maritime Provinces. In British Columbia, however, there has presumably been an increase.

It will be seen that the increase in the wheat area of the principal producing countries outside Europe during the decade ending with 1880 was enormous, while that of European countries was small. But when we come to compare the figures for the next decade, we find that wheat-growing has made but a slight proportionate increase, while the population of all these countries together has increased by tens of millions. What was the cause of this remarkable change? Unquestionably it was the excessive competition in wheat production, which affected growers in new countries as well as in old ones.

In 1882 the farm price of wheat in the United States fell to 88.4 cents a bushel, and the wheat area declined in the following year. But in 1883 the farm price was 91 cents, and the acreage increased in 1884 to 39,475,885 acres, the greatest area ever grown. The excess over the previous maximum of nearly 38,000,000 acres, grown in 1880, was, however, in great measure attributable to the exceptional mildness of the winter 1883-4, which allowed of all the wheat sown being harvested, and so coming into the statistical record; whereas, in most years, a million or two of acres of wheat are winter-killed, or otherwise destroyed, and ploughed up. But in 1884 the farm price fell to 65 cents a bushel, and the wheat area of 1885 was 34,189,246 acres, partly owing to the fall in price, and partly through

winter-killing. For the next three years prices continued very low, the December averages being 77 cents, 68·7 cents, and 68·1 cents a bushel for wheat on the farm. These were ruinous prices for American farmers, and in the old-settled States the wheat acreage fell off to such an extent that all the planting on new lands only about balanced it. An advance to 87·3 cents a bushel in 1888 brought the wheat area once more above 38,000,000 bushels in 1889; but the price of the latter year fell to 69·8 cents, and the area of 1890 was only 36,087,184 acres, or nearly two million acres less than it was ten years before, while the population of the United States had grown by 12½ millions. During the decade many millions of acres of new land were settled, and wheat was grown there as a matter of course, no other crop being regarded as so suitable to start with. Yet, without dwelling upon the difference just shown, which might be regarded as partly accidental, we see that the wheat area was, at best, only stationary.

It would be wearisome to readers to have the details of the changes of wheat area in the several States placed before them. Nor is it necessary to go into detail. The broad fact of a stationary wheat area, with a rapidly increasing population, proves that, on the whole, wheat-growing was not found remunerative to American farmers after the market price fell below a dollar a bushel, and the farm price lower still. Serious depression was felt as early as 1884 in the greater part of the country, as stated at the time by American authorities quoted elsewhere,<sup>1</sup> to which readers desirous of details may be referred. By 1890, however, a turn in the tide had set in, for the market price in the autumn of that year rose above a dollar, and the December farm average for the whole country was 83·8 cents. This gave encouragement to growers, especially as they began to hope for a permanent recovery of lost value; and for the harvest of 1890 they increased their wheat area to something over 39,000,000 acres, the exact area not having been given at the time of writing.

Turning to the figures for Canada, we find only a trifling increase, if any, in the wheat area for the ten years, in spite of the settlement of Manitoba and the North-west, which has taken place almost entirely within that period. Only 51,203 acres of wheat were grown in Manitoba in 1881, while 746,058 acres were grown in 1890. Yet the acreage in the older provinces has fallen off so materially as nearly, if not quite, to balance the increase in the newly-settled country, as already stated. In

<sup>1</sup> *The British Farmer and his Competitors.* Cassell and Co. 1888.

Ontario the area of the crop was less in 1890 than in 1883 by about 350,000 acres, and it is known to have been greatly diminished in Quebec and the Maritime Provinces also. In 1891 about 41,000 acres of the lost acreage were recovered. There is no doubt whatever that the farmers of Ontario and other parts of Canada have suffered severely from competition. The *Toronto Globe* recently stated that the value of the farm lands of Ontario had been depreciated 25 per cent. Probably this is an exaggeration; but the official records of value, according to assessment, show a serious decline. In an article published on October 28, 1891, the *Globe* says:—"The position of a large number of farmers, almost the entire class of renters, had become so critical, because of short crops and low prices, that nothing but this year's good harvest has saved many of them from the sheriff. For this they may give thanks. But their thanksgiving can be for little more than that there has not come upon them a finishing disaster. They could not have lived through another bad year." Last year, it is added, many of the farmers did not pay a dollar of rent. "The landowners and the loan companies will get about all the profit there is in the harvest. They receive their rents and interest, while the farmers have only the permission to continue for another year their untiring work and grinding economy." It is admitted that the stress of past years has not borne so heavily upon farmers who own land free of encumbrance; but these are said to be much in the minority. The renting of land has become much more common than it was, and is the prevailing system in some large districts, owing to the exodus of young men and the operation of the farm mortgage. There are, of course, farmers in Ontario, Manitoba, and other parts of Canada, who have held their own and even saved money during the bad times, just as there are in this country; but all evidence shows that they are the minority. The great Bell farm, from which we were told a few years back that wheat could be laid down in Liverpool with profit at 22s. a quarter, has gone the way of nearly all other "Mammoth" farms in Canada or the United States, and is now cut up into small holdings. British farmers have nothing to fear from Canadian competition in wheat production. They can undersell the farmers in the old provinces of Canada in British markets, and in Manitoba and the North-west growers are and always will be handicapped by the almost regular occurrence of frost when their wheat is in its milky stage, and so in a condition to be spoilt for European markets.

In Australasia there was a great addition to the wheat area in the decade ending with 1880, and a smaller but still con-

siderable one in the next ten years as a whole. But the total for 1890 was smaller by about 100,000 acres than it was in 1887. Moreover, the figures for 1891 show a decrease, as compared with those of 1890, in every Australasian colony; the total being 3,537,091 acres. Speaking for South Australia, the *Adelaide Observer* of August 31, 1891, said:—"Very many wheat-growers have arrived at the conclusion that wheat-growing by itself will not pay, and there are many hundreds of acres being planted with vines and fruit trees;" also that the farmers "are devoting their thoughts to sheep and other sources of employment for their energies." Similarly, in Victoria, the *Australasian* says:—"We hear from several districts of an increasing demand for sheep by farmers who have hitherto turned their chief attention to grain. The low prices ruling for the latter cannot fail to influence the character of Australian agriculture. Our farmers are evincing an inclination to vary their risks, and eventually, no doubt, farms in this colony will be assimilated more nearly to those in the United Kingdom."

This unanimity of testimony in regard to the two principal wheat-producing colonies of Australasia is all the more significant from the fact that wheat in recent years has been very nearly as high in price at the Antipodes as in England. Even in New Zealand, wheat-growing has declined in recent years, the area in 1882 having been 390,818 acres, and in 1891 only 301,460 acres. Between 1885 and 1888 there was a recovery; but since the latter year the acreage has fallen off by more than 60,000 acres. Agricultural depression in New Zealand has long been notorious, and it has been equally severe in South Australia, while in other Australasian colonies there has been only a question of its degree. The Colonial Governments have been frequently called upon to relax the very easy conditions upon which they have leased land, to excuse payments due, and even, in some cases, to provide seed for distressed farmers.

Statistics for India as far back as 1870 are not available. But there is no doubt that the wheat acreage increased considerably during the decade ending with 1880. There was a further increase, too, stimulated by the trade with Europe, up to 1886, when the area harvested was about 27,405,742 acres; but the final report of the Revenue and Agricultural Department for 1891 puts the total at only 24,773,000 acres, thus showing a decrease of over 2,600,000 acres since 1886. This is all the more remarkable from the fact that the rupee prices of wheat and other food grains in India have been exceptionally high during the last five years. The apparent anomaly seems to show that the Indian authorities who contend that the export

of wheat from India is not beneficial to the growers are right. The ryots are in the hands of the money-lenders, and it is the latter chiefly, together with the shippers, who get the benefits arising from the trade with Europe. Hence is it that the ryots are not keeping up their wheat acreage.

There are no satisfactory agricultural statistics for South American countries. In the Argentine Republic the wheat area has increased considerably in recent years, and exports to Europe in three of the last four years were much greater than ever before. The total, however, has only once exceeded a million quarters, and has seldom been more than half that quantity. In Chili there is no sign of wheat production doing more than keep pace with growth of population. Exports in 1883 were greater than they have ever been since, and they have fallen off greatly since 1888. Besides, whatever these countries send to Europe is fully balanced by the imports of other South American countries from the United States, and may be regarded as so much deduction from the American surplus which would otherwise be available for Europe.

British possessions not already mentioned, including South Africa, are wheat-importing countries, and have been so in years when the price of wheat was much higher than it is now or is likely to be in the near future. They may, therefore, be dismissed from consideration.

There are minor sources of the supply of wheat to Europe, such as Algeria, Egypt, Persia, and Asia Minor, for most of which no details as to acreage are available. On the whole they do not appear to have increased their exports in recent years, some having sent more and others less. In the countries among them of which we know most, wheat-growing has not been profitable since low prices prevailed. This is stated in reports on Algeria, and we know it to have been the case in Egypt, because that country has reduced her exports of wheat by 50 to 75 per cent. since 1883.

Seeing that, since 1880, the population of the world has been steadily outpacing the wheat area, the question arises as to why it is that the price of wheat has not risen permanently before this time. The answer is not difficult. During the first half of the last decade the excess of wheat production was not fully overtaken by the increase of population, and during the second half there were some extra good crops in Europe, with generally fair or good ones in the United States. A steady rise was confidently expected in 1888; but the Russian wheat harvest proved phenomenally abundant, and as the harvest of 1887 had been a very good one, large stocks of wheat were

accumulated in Russia. There were excellent crops also in the other principal producing countries of Europe in 1887 and 1888, and in India in the latter year. In 1889 Europe had a poor harvest on the whole, though France was fortunate, and hopes of improved markets revived: but the American crop was a great one, while reserves of old wheat in Russia proved to be much greater than they had been supposed to be. Still, reserve stocks in Europe became small by the end of the cereal year 1889-90, and the harvest of 1890 in America was a very poor one. Again, however, Europe produced a large crop, France having the greatest on record, and Germany, Hungary, and Italy much above average. Thus, during a time when, under ordinary circumstances, the growth of wheat in the world would not have been sufficient to provide the people with bread, an exceptional sequence of productive seasons prevented scarcity. At the end of the last cereal year, however, reserve stocks of wheat in the world were probably lower than they have been before in the memory of the oldest living member of the grain trade, and, in spite of the phenomenal crop of the United States, and extra produce in India and Canada, the extreme shortness of the wheat and rye crops of Europe (rye counting with wheat as a bread-stuff) has sent prices up considerably, and will probably enhance them in much greater degree before next summer.

Two other points must be mentioned in explaining why prices kept low throughout a period of diminishing supplies of wheat in proportion to consumption. One is the almost entire cessation of legitimate speculation in England and America, so far as it consists in holding stocks of wheat; and the other is the rapidity with which, by means of the electric cable and fast steamers, grain can be conveyed from one country to another. Under the comparatively new system of time-bargains millers and merchants have no need to accumulate stocks, as they can purchase at a fixed price, for delivery months hence, any quantity of wheat which they require. They thus insure against any sudden and great advance in values due to temporary scarcity. They can, and do to a great extent, in America especially, transact their business on the system of the racing bookmaker, by trading in "options," and paying or receiving "margins," when they do not desire to deliver or receive grain. And if at any time receipts of wheat in this or another importing country are falling off, the telegraph at once conveys the news to exporting countries, and steamers laden with grain are quickly on their way. These agencies tend to level prices, and to keep them at a low level in periods of comparative scarcity.

With respect to the future of competition in wheat production, the foregoing statements lead up to my conclusion respecting it. My argument is that wheat-growing has not been generally remunerative in any of the considerable producing countries, with the possible exception of India (where the currency question comes in), at such prices as have prevailed in recent years, as proved by the fact that production has not kept pace with population, but has, as a rule, been stationary or declining, while population has been growing rapidly. Hence I conclude that prices must range higher, as a rule (of course, with fluctuations); in the future than they have ranged in recent years, in order to induce farmers to extend the acreage of wheat. At the same time, I am of opinion that a moderate rise in prices will induce growers in the chief producing countries, and especially in countries outside Europe, to enlarge the wheat area to a sufficient extent. For a time at least, it seems probable that an average of 40s. a quarter in England will represent prices elsewhere high enough to induce the necessary extension. Whether a lower or a higher average will be necessary in the next century will depend upon many circumstances, such as the opening up of new countries, the improvement of economic production and transport, and the rate of increase in the world's population.

Although I do not entirely agree with the conclusions of Mr. C. Wood Davis, an American agriculturist and statistician, whose writings have attracted a good deal of attention, it is worth while to cite a few of his most important statements in support of my argument. Adopting an exaggerated estimate of the present wheat area of the world, Mr. Davis puts the increased wheat production for the decade ending with 1890 at 62,000,000 bushels, against which he sets an indefinite but considerable reduction of the rye acreage of Europe. But during the same period, he says, the bread-eating populations of European blood (including Americans, Colonials, &c.) have increased by 42,000,000, requiring increments of more than 170,000,000 bushels of wheat and 100,000,000 bushels of rye per annum. So far as the details he gives can be checked, it appears to me that he has not at all exaggerated his case in this retrospective portion of it. But when he ventures into the field of prophecy, I cannot accept his conclusions. After 1895, he contends, America must either import bread-stuffs, cease to export cotton, or lower the standard of living. Allowing for a diminishing rate of increase of population, and a consumption of staples at the present estimated rate per head, he brings out a deficiency of 1,200,000 acres for 1895, increasing to 17,300,000 acres for 1900, and to 50,000,000 acres by 1906.



The weak point in this calculation is its want of allowance for increased production per acre, and increased area to be made available by means of irrigation of immense tracts of arid land. Official statistics show that the area of land not settled in the United States, apart from the arid tracts, is comparatively small, and is rapidly vanishing. Mr. Carter, Commissioner of the General Land Office of the United States, in his report for the fiscal year ended June 30, 1891, says:—"In the progress of the settlement of the public domain, it has become a question of the greatest practical importance how the thousands of people now yearly seeking homes on the public lands from all quarters of the Republic, and who may be expected to do so hereafter, are to be provided with the homes for which they seek. Very little desirable public land remains unappropriated outside of the boundaries of what may be termed the arid region." The Commissioner goes on to cite the mad scramble for land which occurred about two years ago when part of the Oklahoma Territory (an old Indian reservation) was thrown open, as a proof of the scarcity of land on which crops can be raised without irrigation. Since he wrote a still more striking corroboration of his remarks has been given; for, in spite of the fact that numbers of the settlers in the first portion of Oklahoma were known to have suffered from severe destitution, on the opening of a further tract in the same territory last summer, there was as mad a scramble for quarter-sections of land as there was on the occasion just mentioned.

Still, long before any considerable deficiency of acreage could be experienced in a country which has been holding the leading position among the producing countries of the world, prices would have been forced up sufficiently to render irrigation and high farming remunerative. Mr. Davis's prediction might be accepted as true in a broad sense if he could prove that, during the next fifteen years, unpopulated or thinly-populated countries are likely to be able to produce wheat and other agricultural staples much more cheaply than America can produce them. That he cannot show this, at any rate as far as wheat is concerned, is indicated by the fact that his own figures, if approximately correct, prove that during the past decade of low prices the wheat acreage of the world has increased by only  $5\frac{1}{2}$  million acres (too liberal an allowance probably), an addition far short of the extra area required to feed the increase in population. Moreover, he declares that five conditions must prevail in any country to insure a great and speedy increase of grain production—favourable climate, fertile soil, an unemployed area, sufficient population, and ample means of transportation. Australasia, Siberia, and the River

Plate countries, he adds, are the only great tracts in which even the first three of these conditions prevail. In making this statement he allows too little and too much; for there are other parts of South America and tracts of land in Central Africa in which his first three conditions prevail, while it is too much to say that the climate in La Plata or great portions of Australasia is favourable to grain-growing, which is precarious without irrigation. In Manitoba and the North-west of Canada there are climatic disadvantages of a different kind, though scarcely as formidable as drought in Australia and the River Plate, with rust and locusts added. But some of his conditions are wanting in every undeveloped country.

In the United States, on the other hand, nearly everything would give way to wheat at a dollar a bushel (say 33s. a quarter) as the average farm price, or the equivalent of about 36s. a quarter at Chicago, or 39s. to 40s. at New York. At present freights this would be equivalent to fully 46s. for American wheat in Liverpool, a price which would be contemporaneous with an English average of about 40s. in a year of fair quality and condition for our wheat. The wasteful system of rearing cattle on ranges will soon disappear if grain sells well enough to afford a living profit to producers; and, as live stock come to be concentrated on less ground, improved farming will necessarily take place in order to feed them, and they, in their turn, will increase the fertility of the soil. That America, before very long, will cease to be a great and regular food-exporting country is probable; but there is no reason to expect that it will become a food-importing country in the near future. The average yield of wheat in the United States, which was only 11·8 bushels an acre for the ten years ending with 1890, and only about 12·3 bushels for the like period ending with 1891, might be doubled under favourable conditions, but only with wheat at such a price that American competition would cease to be formidable to growers in this country. The fair deduction from Mr. Davis's statements is that the days of extremely cheap agricultural production are drawing to an end, and that the advantages which new countries have held over old ones are growing less and less.

Other sources of considerable wheat supply outside Europe are not likely to increase their exports at a lower price than America will increase her supply. It has already been shown that the wheat area of nearly all of them has been diminished of late, and it is a fair assumption that their production will not keep pace with population under conditions less satisfactory than will be necessary in the United States. In India, all

authorities agree, it will be all that can be expected if the production of food keeps pace with the rapid growth of population ; and India is the only great producing country outside Europe which appears to me to be able to compete on favourable terms with America. Hence it may be concluded that prices will require to be considerably higher than they have been in recent years in order to supply Europe with bread for her increasing population. As to European countries, it seems probable that they will be able to hold their own against outside sources of supply in the production of wheat, but that they will be able to do no more, at the most, than keep pace with the European population, and probably not so much. This means a continuous supply from outside Europe of the large quantity at present required. The resources of the Russian empire are enormous, no doubt ; but the extreme poverty of the people, the grinding system of taxation, the ruinous exactions of money-lenders, and the wretchedness of the farming tell against rapid development.

It is to be borne in mind that an increase of several millions of acres in the wheat area of the world is necessary at once, in order to allow of production overtaking consumption. After that has been accomplished, a yearly increase of some millions of acres will be needed, unless the yield per acre is greatly increased, to keep pace with the consumption ; and this will not happen unless prices are fairly high. A moderate rise may stimulate too rapid an increase of wheat-growing for a year or two, so that prices may fall ; but reaction would soon set in under such circumstances. Lastly, then, as far as this point is concerned, it is my firm conviction that such extremely severe competition in wheat-growing as has greatly reduced the wheat acreage of this country will not be experienced, as a rule, in the future.

With respect to *barley*, it is to be observed that competition has not been as severe as it has been in the case of wheat. In the ten years ending with 1879, the yearly average ranged from 3*ls.* to 4*0s.* 11*d.* a quarter, and it was not before 1881 that it fell below 3*2s.* for a long series of years. Since that year the area of the crop in the United Kingdom has been reduced by less than 364,000 acres, and our imports have increased by barely the produce of those lost acres, or by less than 1,500,000 quarters. Since 1882 and 1883, indeed, there has been no average increase in annual imports. It seems probable, then, that the reduction in price has been less owing to foreign competition in barley itself than to some other causes, such as the great increase in the imports of certain feeding-stuffs, the

use of malt substitutes in brewing, and the reduced price of wheat, which always rules the values of other kinds of grain to some extent. The principal increases in imports have come from Russia, Roumania, Turkey, and Austria-Hungary, while France, Holland, and Denmark have fallen behind. Countries outside Europe send us very little barley. The United States, having imported extensively from Canada, will have less than ever to spare under the new tariff. Canada may send us what she has been accustomed to supply to the United States, if she can grow sufficient of the two-rowed barley of good enough quality. Some barley of excellent quality has been grown; but it is easy to select a few choice samples in almost any country, and one report states that a large proportion of the two-rowed variety that has been produced is not good enough for our maltsters, while it would not pay to send any considerable quantity of grinding barley to this country in the future, any more than it has paid in the past. Apart from this question of Canada as a new source of the supply of malting barley, the fact that our imports have not increased during the last seven years seems to show that our prices have not been such as to tempt foreign growers to grow more barley to send us, and that there is no reason to apprehend any great increase of direct competition. On the contrary, if more wheat be grown, as it must be, the probability is that barley will be less cultivated. As far as grinding barley is concerned, there may be greater indirect competition, if the imports of maize continue to increase as they increased in 1890, and if other feeding-stuffs keep up the advance made in recent years.

It is curious to notice that, until 1890, there was no marked addition to our recent supplies of *maize*. We imported nearly 42,000,000 cwt. in 1878, and have never received so much since, except in 1890, when the total was over 43,000,000 cwt. During the five years preceding 1890 we imported about 2,000,000 cwt. per annum more maize than in the five years preceding 1885. The principal contributors of the increase were Roumania, Russia, and the Argentine Republic, America having sent us less, although the area of the American maize crop was extended by 12,000,000 acres in the ten years. British farmers as a class would not desire to see the supply of maize fall off, as they use it extensively for feeding purposes. This year it has come in comparatively small quantity, and one result has been a great advance in the prices of cake. As far as barley-growers are concerned, a reduction in maize imports would probably be beneficial; but competition in meat production would be harder to bear in consequence. Maize will be

more and more needed in America as a feeding-stuff, as the stock ranges get broken up, and the crop is such a favourite one that its extent is not likely to be contracted unless wheat becomes decidedly dear, especially as the former cereal flourishes where the latter gives a very scanty yield. In South America, Africa, and the sub-tropical parts of Australia, too, maize does well where wheat is comparatively a failure, so that the wonder is that its cultivation has not been extended even more than has been the case. Growers of grinding barley, then, cannot be comforted with the prospect of a diminished supply of maize, in the near future at any rate. At the same time, there is no reason to suppose that America, which at present sends us more than half the maize we import, will spare additional quantities in the future, for reasons which may be gathered from preceding remarks as to the greater home use expected, and the necessary addition to the wheat area.

*Oats*, like barley, kept up well in price until 1879, and did not fall below 20s. a quarter as a yearly average till after 1885. There has not been any considerable reduction in the oat area of the United Kingdom during the last ten years. The average for 1876-80 was 4,170,325 acres, and for the five years ending with 1890 the average was 4,231,404 acres. But since 1887, when we grew 4,418,947 acres, there has been a fall to 4,137,790 acres for 1891. The area in 1887 was nearly the greatest recorded, that of 1886 having exceeded it by only twelve acres. But the average price fell to 16s. 3d. in 1887, and the area dropped to 4,177,121 acres. As in the case of barley, the fall in the price of oats does not appear to have been caused by direct foreign competition in that grain. It is true that the imports in 1887 were nearly a million hundredweights more than in the preceding year; but that was not a considerable proportion of our national consumption. In 1888 there was an exceptional supply of foreign oats, amounting to 18,770,686 cwt.; but in the next year the supply fell off by about 2,750,000 cwt., and in 1890 it was under 13,000,000. When the fall took place, the average annual imports for five years had been a little less than in the preceding five. Even for the last five years the yearly average imports have exceeded those of the preceding five years by only 2,000,000 cwt. This quantity is equal to about 700,000 qrs., which is not a very great addition to our total supply, seeing that the home crop is over 20,000,000 qrs. It is the cheapening of maize, barley, and other feeding-stuffs, rather than the addition to our imports of oats, that has caused the drop in the price of that grain, partially recovered in 1890, and more still in

1891. The only country which has greatly increased its supply of oats to the United Kingdom is Russia; Sweden, Canada, and Denmark having fallen off greatly in recent years. From America our supplies of oats are insignificant, although the acreage of the crop in that country has more than doubled since 1879.

So many English farmers are buyers of oats that the desire for a high price is by no means universal, while the large proportion of the produce consumed on farms renders the question of price less important than it is with respect to other cereals. Still, as our national production of oats is much greater than that of wheat or barley, remunerative prices are highly desirable, and it is comforting to growers to see that Russia is the only country threatening them with any material increase of competition. It is strange to find that the oat area of Russia was only slightly greater for 1883-7 than for 1870-9. Possibly there has been an extension during the last few years; but there are no more recent statistics of area than those of the series of years above mentioned. On the whole, seeing how supplies from other countries have fallen off, the prospect is one of diminishing rather than of increasing competition in oats, and the chief danger of low prices seems to lie in a possible increment in the supply of maize.

Seeing that *beans and peas* are nitrogen-accumulating crops, it is desirable that their lost acreage should be restored. Prices are fairly high now, but have been low in recent years, and the acreage of both crops has been considerably reduced. In 1871 there were 550,613 acres of beans and 391,250 acres of peas in the United Kingdom, while this year there were only 359,039 acres of the former cereal, and 204,972 acres of the latter. The decline in the cultivation of beans has been steady, with slight fluctuations up to the present year, but very slow since 1886; while in peas there has been no considerable change since that year, when, indeed, the area was exceptionally small, and less than it was in 1890. During the last ten years our imports of beans have increased, though not steadily. They amounted to 2,577,133 cwt. in 1880, and to 3,344,918 cwt. in 1890, but were greater in 1883, 1884, and 1885 than they were last year. The principal increases have been in supplies from Morocco and Turkey, while Egypt, still the greatest contributor as a rule, has fallen behind of late. No steady increase has taken place in imports of peas during the last decade. Indeed, except for the extra quantities of 1887 and 1888, there has been a falling off, the totals for the last two years having been the smallest in the ten years' record. It is strange that Canada, a country admirably suited for the production of peas,

and still the chief source of our imports, has diminished her supplies. Apparently our prices have not been good enough. America also has fallen back, while India in some years has stood next to Canada, with Russia in the third place, and Germany fourth. The small supplies from Morocco and Holland have increased of late; but the only steady and important increase has been in the Russian supply. Peas and beans, like barley and oats, appear to have been cheapened "in sympathy with" maize, cakes, and other important feeding-stuffs, rather than from direct foreign competition, and this connection will probably hold good in the future. Imports of *linseed*, *cotton seed*, *oil-seed cakes*, and *miscellaneous feeding-grains* have all increased greatly during the last ten years, and much more during the twenty years ending with 1890. As to maize, it has been pointed out that the increment, until 1890, had not been remarkable during the last decade; but in 1870 our imports of that grain were only 16,756,783 cwt., and they were nearly the same in the following year, whereas in 1889 they were 36,192,325 cwt., and, in 1890, 43,437,834 cwt.

It has already been remarked that prospects as to the future supplies of maize are doubtful, and this must also be said in respect of cotton seed and linseed. But there is much more reason to expect a large increase in the production of maize than in either of these seeds, which may be regarded partially as bye-products, their supplies being in great measure ruled by the demand for cotton and flax, although the oils obtained from them are valuable, and one, at least, is indispensable. If flax were not grown partly for the seed alone, as in America, as well as partly for the fibre alone, as in Ireland, the supply of linseed would not keep pace with the demand, as the consumption of flax, judging from our imports, has been about stationary for the last decade. Supplies of cotton, on the other hand, have steadily advanced, and presumably will grow with the population. If wheat rises in value, beans and peas, like other grain, are likely to go up more or less "in sympathy with" it; but there seems to be no reason to expect a rise through the falling-off of imported feeding-stuffs which compete with pulse.

The almost stationary imports of *flax* have been incidentally alluded to. They were smaller in the five years ending with 1887 than in the previous quinquennial period, but have gone up since that year, contemporaneously with a decline in our home production. The question of flax culture is one for which there is no space available to me on the present occasion; but it is my opinion, after giving a good deal of attention to the subject, that we could compete with the world in the supply of flax for

our own markets, if sufficient trouble were taken to render the conditions of preparing and disposing of the fibre tolerably favourable.

A rise in the prices of corn would in various ways affect the production of *meat*. In the first place it would reduce the consumption per unit of the population, unless wages in all classes of industry advanced at least in equal proportion. It would also increase the cost of producing meat, as all feeding-stuffs would be dearer than they have been recently. But, as these results would be felt everywhere, they would not materially affect competition. On the other hand, if corn-growing can be made more remunerative than it has been for some time past, meat-producing, other things being equal, would also pay better; for, the profit of the feeder in this country frequently, if not usually, consists in the manure produced, and the more valuable the crops grown by the help of the manure are, the greater is the profit referred to. So far we have a probably diminished consumption of meat per unit of the population, and an increased cost of producing it, to set against the increased value of the manure. How the balance would work out for meat production, considered by itself, it is impossible to say; but as most producers of meat are also growers of corn, there is no doubt as to the advantage which they would derive, on the whole, from the changes mentioned. But this is not all; for although a rise in the cost of bread would probably diminish the consumption of meat per unit of the population, the growth of population would still give an increase of total consumption. Again, while in an old country, like our own, the restoration to arable cultivation of the land laid down in pasture during the last twenty years would allow of more rather than less meat being produced, the breaking-up of great cattle ranges and runs in new countries, in order to grow more corn, would increase the cost of meat production in a far greater proportion than the increase would be with us. On the whole, then, so far as the changes mentioned go, it appears to me that there would be a clear advantage to producers of meat in this country.

There are, however, other considerations bearing upon the future of competition in meat production, and, in order to bring them into a clear light, it is necessary to give a brief retrospect of past competition and its results.

When comparing the imports of *live stock and meat* for different periods of the last twenty years, the wonder is that prices have kept up as well as they have. The case of breeders may be dismissed at once, as they have seldom, if ever, done better—taking the class as a whole—than during the last three or four years, although in 1891 they have not obtained the



extraordinary prices of 1890. They have suffered more from the diseases of live stock than from foreign competition. In the price of meat, however, there has been a decline, although a smaller one than might have been expected. As our home production of meat actually fell off during the decade ending with 1880, there was bound to be an increase of imports. It cannot be said that the decline in home production was due to foreign competition during that decade, because prices advanced during the greater part of it. In the next decade, on the other hand, when prices did fall, the home production of meat became greater, chiefly owing to the revival of breeding which followed the partial relief of breeders from losses incidental to the prevalence of stock diseases. The following table gives the numbers of cattle, sheep, and pigs in the United Kingdom for the three periods dealt with in the preceding portion of this article :—

	1870	1880	1890
Cattle . . . . .	9,235,052	9,871,153	10,789,858
Sheep . . . . .	32,786,783	30,239,620	31,667,195
Pigs . . . . .	3,650,730	2,863,488	4,362,040

For 1891 we have further increases in cattle and sheep, with a falling-off in the number of pigs, the numbers being

Imports	1870	1880	1890
	No.	No.	No.
Cattle . . . . .	202,172	389,724	642,593
Sheep . . . . .	669,905	941,191	358,458
Pigs . . . . .	96,172	51,131	4,036
	cwt.	cwt.	cwt.
Beef, fresh . . . . .	12,035	727,392	1,854,593
Beef, salt . . . . .	203,713	290,564	274,726
Mutton <sup>1</sup> . . . . .	—	—	1,656,419
Pork, fresh . . . . .	36,481	25,056	45,295
Pork, salt . . . . .	220,533	384,211	254,857
Bacon . . . . .	536,844	4,387,082	3,790,570
Hams . . . . .	30,320	947,566	1,209,446
Meat preserved . . . . .	83,081	655,800	734,811
Meat unenumerated . . . . .	34,300	149,010	103,881
Total dead meat . . . . .	1,157,307	7,566,681	9,924,598
Deduct exports . . . . .	22,952	488,000 <sup>2</sup>	1,454,168
Net imports . . . . .	1,134,355	7,078,681	8,470,430

cwt.

Increase in net imports of dead meat for ten years ending 1880, 5,944,326  
 " " " " " " 1890, 1,391,749

<sup>1</sup> Previous to 1882 mutton was included in "meat unenumerated."

<sup>2</sup> Exports of British and Irish meat, included in "provisions" until 1882,

11,343,686 cattle, 33,533,988 sheep, and 4,272,764 pigs. The addition to our home meat supply derived from the increase in live stock, however, falls far short of that derived from foreign sources. The imports of the three periods are given on p. 761.

Poultry and game, the returns for which are in value only, are not included; nor are rabbits, which were not distinguished prior to 1886, but were probably given with poultry and game, in value only. In 1890 we imported 143,641 cwt. of rabbits. I have worked out the weights of imported cattle, sheep, and pigs for the years 1880 and 1890, in accordance with the estimates of dead weight given some years back in the *Agricultural Returns*, and the results allow of the following comparison of live and dead meat imports:—

	1880	1890	Increase in 1890
	cwt.	cwt.	cwt.
Dead weight of live stock .	2,849,290	4,039,000	1,189,710
Net imports of dead meat .	7,078,681	8,470,430	1,391,749
Totals . . . . .	9,927,971	12,509,430	2,581,459

Prices were never higher than in 1873-8; or, indeed, excepting 1879, I might say 1873-83. In the next table I extract from the *Agricultural Returns* the ranges of prices in the Metropolitan Cattle Market, per stone of 8 lb., sinking the offal, for 1870, 1880, and 1889 (the latest year given); also averages for periods which show more fairly the decline in prices:—

## BEEF

1870 . . . . .	3 7 to 5 6	1876-80 . . . . .	4 5 to 5 10
1880 . . . . .	4 6 „ 5 11	1881-5 . . . . .	4 3 „ 5 9
1889 . . . . .	2 4 „ 4 10	1886-9 . . . . .	2 9 „ 4 9

## MUTTON

1870 . . . . .	3 7 to 5 10	1876-80 . . . . .	5 5 to 6 10
1880 . . . . .	5 6 „ 6 10	1881-5 . . . . .	5 7 „ 6 8
1889 . . . . .	3 6 „ 6 4	1886-9 . . . . .	3 7 „ 5 10

## PORK

1870 . . . . .	3 6 to 5 6	1876-80 . . . . .	4 0 to 5 1
1880 . . . . .	4 1 „ 5 3	1881-5 . . . . .	3 11 „ 4 9
1889 . . . . .	2 6 „ 4 5	1886-9 . . . . .	2 5 „ 4 4

The figures for 1870 include foreign animals; but those for 1876-80 and all later dates are for British animals only.

estimated at a little less than the exports of that year. All but about 50,000 cwt. are exports of foreign and colonial meat, for which there were returns in 1880.

Prices for 1890 will probably work out about the same as for 1889, as they were higher for about half the year, and lower for the other half. The averages for 1891, I think, will be a little higher for beef, but decidedly lower for mutton.

It is the lower quality of meat which has suffered chiefly from foreign competition. For instance, while the average for beef of first quality fell from 5s. 11*d.* per 8lb. in 1880 to 4s. 10*d.* in 1889, that of inferior quality dropped from 4s. 6*d.* to 2s. 4*d.* With mutton the contrast is still more marked, the falls for the period being from 6s. 10*d.* to 6s. 4*d.* for first quality, and from 5s. 6*d.* to 3s. 6*d.* for inferior quality.

It is hardly necessary to state that the principal sources of the increased supplies of imported meat are America for live cattle, beef, pork, bacon, and hams; and Australia, New Zealand, and the Argentine Republic for mutton. Our imports of cattle have fluctuated a great deal, but reached their maximum in 1890, while, this year, they have declined greatly. Competition from European countries has fallen off very much during the last ten years, until, in 1890, supplies from these sources were only about one-fifth of the total. This is only to a small extent owing to cattle-disease restrictions, for it is to be noticed in respect of every important European source of supply, and the decline has continued up to the present time in respect of countries for which the restrictions have not altered in recent years. Our prices have not lately been high enough for cattle of the quality of the bulk of the former European supplies. Still, our imports from the United States have so greatly increased that, with a moderate increment in the Canadian supply, the total, as already stated, was greater in 1890 than ever before. This is not surprising, as the number of cattle, other than milch cows, in the United States, increased from over 15,000,000 in 1870, to over 21,000,000 in 1880, and to nearly 37,000,000 in 1890.

The increase in Canada has been small, and the addition to the imports from the Dominion is probably chiefly owing to American cattle being to some extent shipped from Canadian ports. Imports of fresh beef also reached their maximum in 1890, the proportion received from other countries than the United States being less than one-tenth, while it was much smaller in some previous years. The supply of frozen beef from Australasia has made some advance, but is still very small. It will be seen, then, that, under existing conditions, the question of competition in beef-production is dependent mainly upon the ability of American producers to keep up or increase their shipments. Shippers have been greatly helped in recent years by the severe

depression which has prevailed in the American cattle markets. Cattle were so extremely cheap during the three or four years ending with 1890, and cheaper than ever in that year, that, although our prices were somewhat reduced, shippers were able to enlarge their supplies. American papers have reported heavy losses, and have sometimes declared that the export trade of a season as a whole has been done at a loss. The balance-sheet of one great company for seven months ending with September 1890, now before me, shows a loss of over 6,000*l.*, attributed mainly by the directors to the unremunerative returns of the trade with England. But some men must have made the trade pay in the long run, or it would have declined before the present year. Freights have been very low, and this has helped shippers. This year, however, cattle good enough to send here have become comparatively scarce and dear, and some heavy losses are reported, while the supplies have fallen off to a considerable extent. For the ten months ending with October, our receipts of cattle from the United States were only 270,252, as compared with 325,430 for the corresponding period of last year. Fresh beef, however, has increased to the extent of about 37,000 cwt. for the ten months.

The days of very cheap beef-production in America are drawing to an end. As many cattle may be fed on farms as have ever been fed on farms and ranges together, when the ranges are all divided; but they will be reared at a much greater expense. For a time, moreover, it is probable that the proportion of well-bred cattle will be reduced, as a high American authority states that the general quality of farm cattle sold at Chicago is strikingly inferior to that of the range cattle, although the best of the former class are the best of all. This is not surprising, as small farmers, unless they combine, cannot afford to purchase pure-bred bulls, as the "cattle kings" can. The probability is, then, that competition in beef-production for the future will be less severe than it has been in the past, unless some new source of supply is opened up. But there are dangers ahead which it would be foolish to ignore, such as the gradual levelling-up in the quality of cattle in the Argentine Republic and some other South American countries, the increase of breeding in the North-west of Canada, and another change which, if it be possible, might prove most injurious of all to British meat producers. I refer to the discovery of a method of sending meat from Australasia in a chilled, instead of a frozen, state. It has been reported that a method of doing this has already been discovered; but the accuracy of the statement is doubtful, and perhaps the feat will never be accomplished. If it should be,

there is no doubt that our imports of beef from Australasia would increase enormously.

To British breeders, it is hardly necessary to say that the chief danger of the near future is the opening of this country to American stores. A few years hence, however, the effect of such a change, which would be disastrous to our breeding industry at present, would be comparatively small, as the era of cheap production of store cattle in America is passing away.

As far as live sheep are concerned, foreign competition is now trifling; but supplies of frozen mutton have been growing greater and greater every year since they were started, and are growing still. Seeing that they amounted to over 1,300,000 cwt. in 1890, the marvel is that they have not had a greater effect than they have had upon prices. It is true that we cannot tell how high prices would have been if no frozen mutton had been imported; but the probability is that if they had been much higher than they have been in recent years, supplies of sheep and mutton from Europe would have grown, instead of declining, until a lower level of values had been brought to pass. The fact appears to be that European producers of mutton who used to send it to our markets, alive or dead, in considerable quantities, have felt the competition of the frozen meat trade more severely than British producers have suffered from it, because it is low qualities of mutton which have fallen most in value. But, as in the case of beef, if mutton can be sent to us from Australasia and the River Plate in a chilled, instead of a frozen, state, the results will be serious to British producers.

Apart from this consideration, there appears to be no reason to suppose that our imports of mutton will increase materially unless prices keep about up to their present level. The margin of profit on frozen mutton, with freights and freezing charges reduced to a minimum as they have been recently, is extremely small. For the present year, indeed, it is doubtful whether shippers have derived any profit, as the prices of frozen mutton have been very low, and agents in this country have recommended a diminution of supplies. Freights are more likely to rise than to fall, and other expenses have been cut down so severely of late that it is not easy to imagine how any further economy can be effected. If corn-growing becomes more profitable than it has been in recent years, there will be another assurance against the supply of frozen mutton becoming much greater unless the prices of meat in this country are kept up to a fairly high level.

So far as our flockmasters' interests are affected by the competition in *wool*, it is only necessary to state that the

number of sheep in Australasia was greater in 1890 than in 1889 by about thirteen millions, in order to show that there is nothing comforting in the outlook.

With respect to the future of competition in "hog products," to use an American term, I confess that I am altogether uncertain. The number of pigs in the United States increased from 26,751,000 in 1870 to 34,031,000 in 1880, and to 51,602,780 in 1890. Yet our imports of bacon reached the maximum in 1880, and those of salt pork in 1879; neither having been nearly as great since. Hams alone reached the maximum in 1890, but have come in only one preceding year in greater quantity than in 1880. For the first ten months of this year the quantity was smaller than it was in the like period of 1890, though the American supply was increased slightly. The opening, this year, of three European countries—Germany, France, and Italy—to American pork and bacon may help producers in this country to some extent. The importation of live pigs is practically extinct, only 347 having come to us in the ten months ending with October. The greatest number received in any year since 1860, and probably the maximum ever imported, was 133,280, in 1865. There has been a talk of a great trade in Russian bacon; but whether it will ever come to considerable dimensions remains to be proved. So far as can be foreseen, the course of competition in the future will continue to be mainly dependent upon the possibilities of extended and cheap production in America, and as the population of that country grows, the chances are that exports will dwindle, especially if maize becomes dearer. At the present time it is reported in American papers that there will be less fattening than usual of pigs and cattle alike during the winter if maize does not go down in price.

It is not necessary to devote space to a lengthened consideration of competition in *horses*, because it is not breeders in the United Kingdom who have to complain of it. The value of our exports of horses greatly exceeds that of our imports, and there is nothing in sight to reverse the proportion.

Turning to *dairy products*, the first fact which calls for notice is a very striking one. Between 1876 (the first year for which the total is given in the Agricultural Returns) and 1890 the increase in the number of cows and heifers in milk or in calf in the United Kingdom was only 181,017. This year we have a further increase of 161,487; but in considering how foreign competition has grown up to 1890, we are confronted with the fact that, long before there was any complaint of depression among our dairy farmers, they virtually invited

foreigners to contribute extensively to the supply of our increasing population. The increase in cows has probably fallen short of what it needed to be for supplying the growing consumption of milk in the raw state, allowing the utmost for the improved milking capacity of the cows. Moreover, there was only a small increase in the number of cows between 1876 and 1884, and none at all between 1885 and 1890. It must be assumed that the production of either butter or cheese, if not of both, is smaller now than it was in 1876, because the consumption of milk in its natural state has grown so greatly. For Great Britain alone, the number of cows and heifers in milk or in calf was 2,161,804 in 1870, and 2,537,990 in 1890, the increase being 376,186, a very small one for twenty years. Our net imports of butter, margarine, and cheese have been as follows :—

—	1870	1880	1890
	cwt.	cwt.	cwt.
Butter . . . . .	1,101,682	2,294,897	{ 1,814,296 1,058,799 2,036,824
Margarine . . . . .			
Cheese . . . . .	1,016,087	1,764,094	

*Butter* and *margarine* were not distinguished in the returns before 1886; but it will be seen that, together, the net imports of these commodities were more than doubled between 1870 and 1880, and that they increased by not far short of 600,000 cwt. between 1880 and 1890. The decline in the increase in the second decade shows that, during that period, our home supplies increased to a small extent, unless there was a diminished consumption per head of the population. Unfortunately there are no satisfactory statistics of the prices of English butter in past years, and those of imported produce, which are the most trustworthy for comparative purposes, are for butter and margarine together up to 1885. Bearing in mind that margarine has been coming in greater and greater quantity, as a rule, since it was first introduced, the record of prices does not at all account for the great increase in imports up to 1880. The average price of the imports was exceptionally high in 1870; but in 1871 it was 5*l.* 4*s.*, and between that year and 1876, when the average was 5*l.* 17*s.* 1*d.*, there was a regular advance. Then followed a decline; but still, in 1880, the price was 5*d.* more than in 1871, and it was also higher in the next two years. As the increasing proportion of margarine lowered the average, the price of butter alone must have risen up to 1882. In 1886, for which year we get the prices of butter and margarine separately, imported butter averaged 5*l.* 5*s.* 5*d.* per cwt., and in 1889 it was 5*l.* 6*s.* 3*d.*

In 1890 there was a drop to 5*l.* 4*s.* 6*d.* No doubt this price for butter only, compared with as much or more for butter and margarine in earlier years, shows a considerable fall; but it does not explain the increase in our imports up to 1884. If we take the records of prices of Irish butter, we find that top prices were never as high for any other series of years as they were from 1880 to 1884, or, indeed, from 1879 to 1885. Bottom prices were lower than they had been as a rule for some years before 1879; but the averages remained high. Since 1885, however, there has been a considerable fall, with fluctuations in different years, the average for 1890 being the lowest, as far as the record goes. For 1891, it is to be feared, the average will be lower still.

It is well known that spring and summer prices in England have been very low for some years past; but the point now under consideration is that we allowed foreigners to get a good hold upon our markets at a time when butter sold remarkably well. The truth is that our dairy industry had been scandalously neglected for many years before the recent revival in it set in. Since then improvement has been rapid, and, with dairy schools established, or about to be established, in every county, it should be more rapid still in the future. If the fall in the average price of English butter has been greater than the fall in foreign butter, the fault is mainly one of an inferior marketing system, for the best English butter is superior to any that we import, and its proportion is yearly becoming greater. Why should fresh English butter be extremely cheap in the summer, when, at the cheapest of times, none that is fit to be eaten can be obtained at less than 1*s.* 4*d.* a pound in the suburbs of London, while for the greater part of the year the price is 1*s.* 6*d.* to 1*s.* 8*d.*? We are apt to attribute to foreign competition much that is really due to a wasteful system of distribution.

As to the future, I see no reason why British and Irish butter-makers should be beaten by Continental makers, who, at present, are their chief competitors. The United States and Canada have been falling back in their supplies of butter in recent years, having been cut out of our markets to a great extent by Denmark, France, and Sweden. Among our Continental competitors France has made no steady progress, having sent us more butter in 1882 than in any subsequent year, while Germany and Holland have contracted their supplies, though the last-named country has favoured us with great quantities of margarine. Denmark and Sweden, on the other hand, have made steady and great advances; but the Danes are dissatisfied with the prices obtained in our markets in 1890 and 1891. As we raise the general quality of our butter, the opening for sup-



plies from Denmark, France, and Sweden will grow less. It is only in organisation that the makers in these countries are superior to our own; and that inequality we can remedy if we take the necessary pains. If farmers in New Zealand and Australia are satisfied with 2½d. to 3d. a gallon for their milk, and continue to supply the butter factories at these miserable rates, their increasing export trade may grow to considerable dimensions. New Zealand is one of the best countries in the world for dairying, having pasture grass all the year round. But hitherto butter has been sent to us from that Colony and Australia only during the winter season, when it will keep well, and when prices are high. Probably it could not be sent at a profit in the late spring, summer, or early autumn.

Imports of cheese have varied in quantity considerably during the last ten years, but reached the maximum in 1890. Nearly all the increase is due to supplies from Canada, which have more than doubled, while imports from the United States are smaller than they were a few years back. Canadian makers have deserved their success by supplying cheese of excellent quality. On the other hand, the reputation of American cheese has suffered greatly through the extension of the abominable practice of extracting the cream, or part of it, from the milk, and supplying its place with extraneous fats, making what is styled "filled cheese." Judging from the average values of imports, the price of cheese has fallen since 1874, when it was 65s. per cwt. The minimum was 42s. 9d. in 1879; but this caused a great falling-off in imports, and the price rose to 57s. 4d. in 1880. After that year the average fell till it was only 44s. 4d. in 1885, rising once more to 49s. 1d. in 1887, and falling to 46s. in 1890. The averages for British cheese have been higher, no doubt, and the prices are quoted only to show comparative values in different years. In hard cheese of the best quality British makers are unrivalled, and in the supply of such cheese they have no reason to fear future competition. Moreover, if they would take the trouble, they might profitably engage in the business of making some of the choice soft cheeses which we now obtain from France.

The success of foreign competition in *poultry and eggs* is partly owing to the mistaken contempt of British farmers for a small, but desirable, source of profit. The south of Ireland is particularly well suited to the production of poultry and eggs, the climate, as well as the great numbers of separate holdings, being advantages which have been sadly neglected. The figures given below show the increases of imports for the last two de-

acades, though poultry and game are classed together, and values only are given:—

—	1870	1880	1890
Poultry and game . . .	158,482 <i>l.</i>	421,645 <i>l.</i>	497,858 <i>l.</i>
Eggs (thousands) . . .	430,842	747,409	1,234,949

The increase in imports of poultry during the last ten years has not been great; but that of imports of eggs has been both great and steady. Our system of distribution in respect of poultry and eggs is a very bad one, the difference between the prices paid by consumers and those received by producers being inordinately great. An improvement in the marketing system would greatly help home producers.

Growers of *fruit* in this country are now holding their own well against their foreign competitors, and are likely to do so better in future, as production under glass is increasing. With the exception of apples, the imports of fruit consist chiefly of the early produce of more sunny climes than ours, and it is only by the more extensive use of glass houses that we can meet the competition. Apples have come in greater and greater quantity as a rule, since 1882, when they were first separately returned. Imports rose from 2,386,805 bushels in that year to 3,796,592 bushels in 1888, but have not been so plentiful since, because the American crops have been deficient. This year, however, the supply is a large one. There are difficulties in respect of planting fruit trees which cannot be entered into on the present occasion. If they are surmounted, we can easily grow all the apples we need. The system of marketing fruit, however, greatly needs improvement.

Imports of *hops* have fallen off greatly since 1885, so that the depression suffered by English growers recently cannot be attributed to foreign competition. The growth of hops in Australia has declined, and, although it has increased in America, the increment in production, apparently, has not been much if at all greater than that of the demand. The quality of English hops is so exceptionally high that there appears to be no need to fear the future of foreign competition in this product.

On the whole, although there are possible dangers ahead some of which have been noticed, while others may appear hereafter, there is good reason, in my opinion, to take a hopeful view of the future of agricultural competition. One great fact tells unquestionably in favour of the producers of food: namely that while the people to be fed are constantly increasing in

number, the area of land upon which the food can be produced is a fixed quantity. It is true that the cultivated area goes on increasing, and must increase for generations to come; but we have come to a time when the difficulties of opening up new countries are much greater than they were twenty years ago. The temperate zone is nearly all settled, while the growth of common farm products in sub-tropical or semi-arctic regions is attended with great risk. Farming will improve, in newly settled countries especially, as in them there is the greatest scope for improvement; and, consequently, the production of food on a given area will grow greater than it is. But the products will be obtained at an increased cost, so that the needed increment will be forthcoming only under the impetus of enhanced prices. For some time past the cultivators of the soil have not had their fair share in the exchange of commodities and of the means of enjoying life. Although they have not organised in trade unions, they have "struck" nevertheless in the most effective manner, by reducing the output of food with which the world was glutted, and, in some countries, especially in America and our colonies, by flocking into the towns. The result, I believe, will be a return of agricultural prosperity, which will last as a rule, let us hope—though we cannot expect it to be constant—at least as long as the one among us who will live longest will be in the world to see it.

WILLIAM E. BEAR.

---

## PROFIT-SHARING IN AGRICULTURE.

THE subject of profit-sharing in agriculture has of late received a considerable amount of public attention, and it is a noteworthy fact that the Leader of the Opposition and the Leader of the House of Commons have, within the last month, on two successive days, given expression to their common conviction that the system offers a better hope of strengthening the relations between employer and employed, of remedying agricultural discontent, and of bringing about a moral and material improvement in the individual circumstances of those engaged in the production of wealth, than any other principle which has been before the public. When statesmen of both political parties speak of "profit-sharing" in terms so appreciative as those used by Mr. Gladstone at Wirral on November 28, and by Mr. Balfour at Huddersfield on November 30, the principle becomes

lifted out of the range of party politics, and may be discussed impartially as a means—and, as I venture to think, a very potent means—for the improvement of agriculture in this country.

There are two ways of wedding the labourer to the soil: (1) by helping him to purchase a small holding through the action of the State or otherwise; (2) by allowing him to share the profits which may be realised by the farm on which his labour is employed.

In Northumberland, the material condition of the agricultural labourer is so far satisfactory that I cannot think of the name of a single person of common-sense who has ventured to say that the labourer's position would be improved by being transformed from a hind into a peasant proprietor. His condition, in all material respects, when compared with that of the owners and occupiers of very small holdings, is distinctly good. Engaged from year's end to year's end at a regular upstanding wage of from 15s. to 16s. per week, from which no deduction is made on account of either holidays or sickness, enjoying, in addition, the occupation of a good house and garden rent-free, from 1,000 to 1,200 yards of potatoes, and the power on many farms of having a cow kept for him throughout the year at the rate of three shillings per week,<sup>1</sup> the agricultural labourer, so far as his material condition is concerned, may well excite the envy of the great majority of peasant proprietors: who, in return for far greater toil, longer hours, and a more laborious existence, are unable to command so large a proportion of those necessaries and luxuries which go to make up the comfort of life.

---

<sup>1</sup> So much importance is attached, and rightly attached, to the possession of a cow by every household with a young family, that it may be interesting to those who are unacquainted with the customs of the North to know what are the privileges of a Northumbrian hind as regards a cow.

The farmer is ready, at the hind's request, to provide a year's keep and the necessary accommodation for a cow, in return for the payment of 3s. or 4s. a week. For this sum the farmer allows the cow to run out at pasture in summer, and in winter he gives the labourer a sufficient allowance of artificial food.

The advantage to the labourer of this arrangement is greater than may at first sight appear. An average cow will give the labourer a gross income of 5s. to 6s. a week, or even more, and, over and above this, the hind has the skim milk for his own use. He has, therefore, every inducement to try and obtain possession of a cow. Many of the Northumbrian hinds take advantage of this privilege, when they have the money, to purchase a cow, and many more would do so if the necessary amount required to buy the cow could be obtained. On the profit-sharing farms in Northumberland to which I am about to refer the farm is prepared to advance to the hind, out of "the reserve fund," the money required for the purchase of a cow, on arrangements being made to pay off the loan by instalments, for which a lien on the cow and the undivided "bonus" offer a sufficient security.—A. G.

I do not dispute that the proprietorship of a small holding may be of advantage to a person who does not depend solely upon it for the means of livelihood; or that in the neighbourhood of towns, where there is a good market for the fruits of spade-culture, and where favourable opportunities exist for the obtaining of manure, the proprietorship of a small holding may prove a good and paying business. But to suggest peasant proprietorship as a means of improving the condition of the Northumbrian agricultural labourer—as a means of restoring the picturesque and much-regretted yeoman, who has been simply flattened out by the pressure of economic forces—is to suggest a remedy which is founded on nothing better than ignorance and folly.

It is an economic truth, not less, but more, indisputable in these days of improved machinery than in the days when Arthur Young and McCulloch demonstrated the superiority of large over small holdings for the purposes of profitable farming, that the chances of profit rise in proportion to the size of a farm, its size being regulated (1) by the amount of available capital that can be obtained; (2) by the amount of land which an individual can manage in the best and most approved manner.

This being admitted—and it cannot be denied—it remains for us to consider whether the potentialities which lie dormant in the successful application of the profit-sharing system to agriculture do not offer a better hope to the agricultural labourer than anything which the State can be invited to do for him.

Once it is admitted that large holdings yield greater profits than small ones, the object of the agricultural reformer should be to devise some plan which unites the advantages of the two systems—some plan which is able to secure not only the division of labour, the use of new and expensive machinery, and the command of abundant capital, which can only be obtained on large holdings, but the efficient individual labour, which, on peasant proprietorships has, according to Arthur Young, the power of transforming sand into gold.

It may be well to consider, before we proceed further, what is implied by the term “profit-sharing” which Mr. Balfour puts before us as an ideal to be aimed at.<sup>1</sup>

---

<sup>1</sup> “One method, and one method alone, appears to me to exist by which all the benefits that people hope for from peasant proprietorship, and all the advantages which are actually obtained by the system of large cultivation, might be united. Only would this be possible if agriculture could be managed on something like a co-operative system. The problem of our country districts would, I believe, be solved if only we could associate the labourer with the farmer. If only we could make them all sharers in the profits, as they are

It implies that the wage-earner shall share with his capitalist employer any profits which may remain, after labour and capital have received their fair reward, after all the necessary outgoings, such as rent, rates, and taxes have been met, and after a sufficient sum has been credited to the reserve and depreciation fund. It means a partnership in the net profits, but not a partnership in the management.

The object of the capitalist who applies the profit-sharing principle to the management of his business is to interest the labourer in his work to such an extent as will cause him, of his own accord, to do his utmost to prevent waste, to avert loss, and to increase the efficiency of his own and of his fellow-workers' labour.

If the effect of the application of the profit-sharing principle to an industry is to cause the worker to take an interest in the economy and efficiency of his work, then, not only will the employer be likely to gain more than he will lose by the bonus he may be called upon to divide among his labourers, but the very fact that the labourers are all "sharers in the profits, as they are sharers in the toil," will help to establish a pleasant relationship between employer and employed which is in itself an advantage of inestimable value.

The objection is frequently urged against the profit-sharing principle that common fairness requires that any worker who shares the profits of his capitalist employer should also share his losses. The answer to this objection is conclusive.

The labourer in a profit-sharing business, where he has full confidence in the honesty and ability of his employer, is naturally stimulated to show energy, punctuality, diligence, and economy in his work by the prospect of a bonus on his wage. In good years it is only fair that he should receive increased remuneration for the better labour that he gives. In bad years, when the balance-sheet shows a loss, the labourer—without any deduction being made from his wage—is also a sharer of that loss, for, although he has given better labour, not only does he not receive that extra reward to which his better labour entitles him,

---

sharers in the toil, I think we should have got to the end of our difficulties. I am not going to suggest that as a plan of which I myself see the immediate realisation. I know the insuperable difficulties which have occurred in applying the principle to manufactures; and, though I do not despair of seeing it applied both to manufactures and to agriculture, I have frankly to admit that I do not think its realisation is one that we shall see in the immediate future. I put it before you as an ideal to be aimed at; I put it before you as something which we should study; if so, it may be that we may reach it, and if we each of us set ourselves to work in our own districts to solve this problem I should not readily believe that the problem would be found to be insoluble.

— *Mr. Balfour's speech at Huddersfield, November 30, 1891.*

but he has to bear the disappointment which results from the fact that the advantage to which he has perhaps been looking forward for a year beforehand is not forthcoming.

Now, reason suggests, and experience has proved the suggestion to be correct, that, if the profits of a farm are shared with the labourers in such a way as to convince them that their interest is bound up in the success of the farm, their labour will show extra care and extra energy: there will be a diminution of waste on the one hand and a more intelligent application of labour on the other.

There are few agricultural experiments which have arrested so much attention among educated men outside the agricultural world as the very remarkable experiment of Mr. Vandeleur in co-operative farming at Ralahine, co. Clare, during the years 1830-1833. A full account of the Ralahine farm is given in Mr. Sedley Taylor's book on "Profit-Sharing," in Mr. Pare's volume on "Co-operative Agriculture," and in a pamphlet by Mr. E. T. Craig, the manager of Ralahine farm, entitled, "A Remedy for Ireland."

The most disturbed district in Ireland, in one of the most disturbed periods of her history, conspicuous among other portions of Ireland for the number of horrible murders and brutal outrages, was rendered peaceful and contented in an incredibly short space of time by the bold originality and enthusiasm of Mr. Vandeleur, who, an ardent disciple of Robert Owen, resolved in 1830 to apply the principle of co-operation to the cultivation of his estate.

At the time when Mr. Craig was called over from Lancashire to organise the Ralahine farm on the co-operative principle, the condition of that portion of County Clare in which Ralahine was situated was as bad as it was possible to be. The "Terry Alt" was in full blast, and the "Lady Clare Boys" were in their fiercest and most unrestrained humour. No soil could have been more unpromising for an experiment which depended for its success on mutual trust and goodwill between Mr. Vandeleur, his agents, and the agricultural labourers.

The plan adopted was thus described in a paper read before the British Association at Oxford in 1847:—

"The plan adopted was the establishment of an association of labourers, altogether without capital, to whom a certain quantity of land was entrusted in common for cultivation; the landlord advancing the necessary stock, farming implements, and providing dwellings, barns, and farm-buildings, &c., and receiving back the value of the rent of the land, and the interest at the rate of 5 and 6 per cent. on the advances made and money expended, in the produce of the farm at the market price, the surplus to go to the common benefit. The farm was cultivated by the labourers themselves, who were paid in Labour Notes, which were payable in kind at a store on the pro-

perty ; such Notes being exchanged for money for the purchase only of such necessary articles as the farm did not produce. Care was taken to exclude objectionable characters by ballot of the members and, if necessary, by the veto of the proprietor. The conditions of the holding were, that if the stipulated amount of produce for rent and interest was not paid at the end of the first year, or if the stock advanced deteriorated in quantity or value, or the cultivation receded, then the proprietor should have power to take back the farm into his own hands. The value of the produce required to pay rent and interest was 900*l.* a year ; the number of acres to be farmed was 622—326 of which were arable.”

The value of the experiment may be best appreciated by the following quotation from Mr. Pare’s “Co-operative Agriculture” :—

“ ‘ We formerly,’ said one of the labourers in speaking of their condition when working under the direction of a steward, ‘ had no interest either in doing a great deal of work, doing it well, or in suggesting improvements, as all the advantages and all the praise were given to a tyrannical taskmaster for his attention and watchfulness. We were looked upon as merely machines, and his business was to keep us in motion. For this reason it took the time of three or four of us to watch him, and when he was fairly out of sight, you may depend we did not hurt ourselves by too much labour ; but now that our interest and our duty are made to be the same, we have no need of a steward at all.’ ”

“ Before the society was established the labourers conceived their own interest opposed to that of their employers, and would attend to nothing beyond their appointments for the passing moment. If a bullock broke over a fence and trampled down the wheat, they would say, ‘ It’s no business of ours ; let the herdsmen see to it ;’ and thus the wheat was destroyed because they got neither profit nor thanks for their extra trouble. They conceived it to be their interest to encourage clandestinely the destruction of property, believing that it would create a greater demand for their labour. But after the society commenced, this order of things was reversed. A single potato was by many of them very reluctantly wasted, for they found that the conservation of the property was the saving of their own labour. Thus the same faculty of mind—self-interest—produced opposite results when surrounded by opposite controlling circumstances.”

If anything more were required to prove how great a transformation was worked by the adoption of this principle, that proof would be forthcoming in the resolution passed by the Ralahine labourers at the last general meeting of the association :—

“ We, the undersigned, have experienced for the last two years contentment, peace, and happiness, under the arrangements introduced by Mr. Vandeleur and Mr. E. T. Craig. At the commencement we were opposed to the plans proposed by them ; but on their introduction we found our condition improved, our wants more regularly attended to, and our feelings towards each other at once entirely changed from jealousy, hatred, revenge, to confidence, friendship, and forbearance.”

Unfortunately for Ireland, this most promising experiment, which in two short years had benefited landowner and labourers alike, had increased the rent, the rate of wages, and the produce of the farm, and had caused “ drunkenness, disorder,



and want to give place to sobriety, peace, and comparative independence," was brought suddenly to an end in 1833 by the bankruptcy of Mr. Vandeleur, caused by heavy gambling losses. The purchaser of Mr. Vandeleur's Ralahine estate was a man of orthodox views, who ruthlessly put his foot upon a "new-fangled" system, the virtues of which he was quite unable to appreciate.

But though the Ralahine experiment had proved in two years that the temper and character of a district could be transformed by the application of principles which made it to the interest of the labourers that the farm on which they were employed should prosper, there is no other instance, that I am aware of, where a similar system, or even a modified plan of profit-sharing, has been attempted in Ireland: a fact which is much to be regretted when one reflects that the Ralahine experiment accomplished—to quote Mr. Craig once more—"what neither statesmen, soldiers, magistrates, nor political economists, with all their science, gunnery, preachments, warrants, councils, and coercion, could effect."

It was wittily said, in the same volume from which these facts have been gleaned, that an Irishman will either carry you on his back or lay you on your own, as you may treat him. The Ralahine experiment proved, to the common benefit of all parties—of the landowner, of the labourers, and of the State—that the same Irishmen who were thirsting for this latter satisfaction competed for the former so soon as they understood that their interests were bound up in those of their employer.

The other well-known text-book instances of profit-sharing experiments in agriculture are taken from Germany, and I cannot do better than quote from the description of the most interesting experiment conducted by Herr Von Thünen, on his estate, Tellow near Teterow, in Mecklenburg-Schwerin, which is given by Mr. Sedley Taylor in his book on "Profit-Sharing:—"

"To all his regularly employed workpeople occupying cottages on the estate he assigned, over and above ordinary wages paid at the full rate current in the neighbourhood, a share in the profits of farming.

"If after deduction of all outgoings the profits exceeded 825*l.*, each participant was to have one-half per cent. of the surplus above this amount. When, on the contrary, the assigned limit was not attained, the deficit was to be made good out of the next year's surplus. The number of beneficiaries, including bailiff, schoolmaster, cartwright, &c., was twenty-one.

"The individual share in profits was not paid in cash, but credited to a savings account. On the sum therein standing, Herr von Thünen paid 4½ per cent. interest, which was handed over each year in the form of a cash bonus at Christmas. Only at sixty years of age could a participant draw the capital sum accumulated for him. Should he die sooner, it passed to his widow, subject in some cases to partial settlement upon children.

“The above arrangement is still in force, with no important change, save that the sum above which participation begins is now 900*l.*, instead of 825*l.* Herr von Thünen's son, and his grandson, Herr A. von Thünen, the present proprietor, both had full power to abolish the system, but they preferred to retain it.

“Herr A. von Thünen expressed the following opinion of the general results of the system followed at Tellow, in a letter to Professor Böhmert, dated May 25, 1887:—

“The institution has approved itself and borne the fruits which my grandfather hoped from it, at least with the majority of our people; exceptions are, of course, to be met with here as everywhere. The share in profits retains the people on the estate, as, if they quit it, they do not receive their capital, but only the interest upon it. It creates common aims for the proprietor and the labourers, and so brings about a better understanding between the two parties. At the outset most of the people were, I believe, somewhat dissatisfied because their share was not paid over in cash. But by slow degrees, as the capital of individuals grew, they recognised the excellence of the system on this point also, for with many of them the interest which they receive in an ordinary year exceeds the share of profits annually allotted to them.”

Another most encouraging and hopeful experiment in profit-sharing farming, mentioned in Mr. Sedley Taylor's book, is that started in the neighbourhood of Berlin in 1874 by Herr Jahnke. He agreed to divide among the labourers half the net profits which might remain after all the expenses had been paid, including the remuneration that he was to receive for the use of his capital and for supervision. The result of this arrangement was that each associated labourer received on an average 52*l.* 3*s.* in money during each of the three years 1872–75, a time when the highest annual earnings of agricultural labourers in the German Empire was 33*l.* 4*s.* This promising experiment was, unfortunately, brought to an end in 1877, owing to the fact that Herr Jahnke was boycotted by his neighbours, to whom his experiments appeared most objectionable.

With these brilliant examples of what the profit-sharing principle has accomplished in Ireland and Germany, it is a matter for wonder that so few serious attempts have been made to apply this principle in England.

I have not had the opportunity of finding out what profit-sharing experiments are being conducted at the present time in this country, for the short time at my disposal has made it impossible for me to treat this subject with the completeness it deserves. But, judging from the notices in the press, it would appear that, from one cause or another, there is an increasing number of landowners who are taking in hand considerable portions of their estates, and are applying to their cultivation that principle which Mr. Balfour says is the ideal we should ever keep in view.

Mr. Boyd Kinnear, in a letter to the *Agricultural Gazette* of November 30, states that some five or six years ago he was obliged, owing to the drop in rents, to take some of his farms in hand in the county of Fife. He felt that there was a want of a bond of common interest between master and man. He, therefore, told his employés that he would give to them, in addition to the wages current in the market, a bonus in the shape of a percentage upon their wages, out of profits which might remain after he had received a sum equal to the reduced rent which a tenant would give, besides interest on his capital and a salary for superintendence and direction.

The profits ascertained after making these payments he divides between his labourers and himself in the proportion of the market value of their respective interests—theirs being represented by wages—his by rent and interest on capital.

The second year he was able to distribute a bonus of 3 per cent. on their wages; the third year one of 5 per cent.; the fourth year a similar bonus. In respect of the current year, he fears that, owing to the shortness of the crops on account of summer drought, there may be a reduction; but he hopes that the figures may gradually tend to rise, instead of fall, as time goes on. Mr. Boyd Kinnear concludes his letter by observing:—

“I cannot say that this system has made my servants work better, for I have already said they worked faithfully and well before it. But it has, I think, established a sympathy between us, a sense of joint interests, a feeling of ‘being all in the same boat,’ a recognition that they are dealt with fairly and equitably (possibly, perhaps, generously), which has brought an ample reward in pleasant relations, anxiety to do the best to guard against any mischances, and to fall in with my wishes as to any new methods or experiments which I desire undertaken. I can turn my back, or even leave home for weeks, with perfect confidence that the same care will be exercised (to the best of the ability and powers of observation) as if I were present. And as I cannot afford the luxury of a manager under me this item is a very great comfort. In short, while we are still in the relation of master and servants, we have become in the best sense of the word co-operators—and I think friends.”

Lord Wantage is also applying profit-sharing principles, with considerable advantage to his employés, to a large Bonanza farm of 4,900 acres in Berks: 1,900 acres of this large farm, which has been formed by the gradual consolidation of several smaller ones, are permanent pasture, the balance being arable.

Lord Wantage engages the labourers at the current wages in the market, the only difference between the labourers on his farm and other labourers being that on his farm he is in the habit of distributing a portion of the profits among his employés, should they exceed a certain figure.

The farm accounts are audited by Messrs. Kemp, Ford & Co.,

the well-known firm of London accountants, who have instructions to charge the farm, first, with interest at  $3\frac{1}{2}$  per cent., then with rent and tithe, and to show what credit balance there is after these charges have been paid. Without making any engagement to share this net profit with the labourers, Lord Wantage has, roughly speaking, set apart one-third, to be given in the form of bonus.

The bonus given to each man on the farm for the year ending Michaelmas, 1891, amounts to 3*l.*, which is, as nearly as possible, 10 per cent. on their wages. This is the fifth bonus which Lord Wantage has been able to distribute.

In a letter received from Lord Wantage, he says—

“The bonus of 3*l.* goes a long way towards paying the house-rent—in many cases covers it—and in cases where father and sons live in the same cottage it greatly exceeds it. But the advantage of the bonus is chiefly found in the increased interest which it promotes in the men’s minds in the work of the farm, and in the improved relationship between the labourer and his employer.”

And his bailiff, Mr. Eady, writes—

“I am satisfied the system has done good amongst the labourers, and makes them take an interest in all the operations of the year.”

Lord Spencer is likewise making an interesting experiment, but upon more democratic lines. He has rented the Glebe Farm at Harleston, 296 acres, as tenant from year to year, at the yearly rent of 425*l.*, and he provides the capital that is required for stocking and working the farm. The labourers, who are employed at the market rate of wages, are allowed to have a voice in the management through an elected consultative committee, which has the right to confer with the manager on all points connected with the farm.

On this farm, after the rent and interest at the rate of 4 per cent. have been paid, 75 per cent. of the profits are devoted to a reserve fund, until the capital which has been advanced by Lord Spencer has been repaid. This experiment began in 1886, and although since that time no profit has been made, Lord Spencer is hopeful that the experiment will in time prove a success.

On the Castle Howard estate, Lady Carlisle is applying the *métayage*<sup>1</sup> system. The occupiers pay one-third of the proceeds

---

<sup>1</sup> “*Métayage*” is defined by Count de Gasparin, a very famous French agriculturist, as “a contract by which, when a tenant has not capital or credit enough to guarantee the payment of the rent and the advances of the owner, the latter deducts the rent by proportional parts of the harvest of each year, in such manner that the arithmetical mean of these annual portions represents the value of the rent.” It is, in fact, a method of cultivation in which the soil is cultivated by an association between the owner and tenant (who

of all sales to Lady Carlisle, who pays the rent and taxes. This one-third of the produce is said to amply cover the rent, rates, and interest on the proportion of working capital (two-thirds of the whole) advanced by Lady Carlisle. It is claimed that by this arrangement the farmer is enabled to sell everything that is desirable to market, whenever a favourable opportunity offers, instead of being obliged to dispose of stock and produce when rent-day draws near, whether the markets are favourable or not. He has every inducement to economise labour, because he has to pay for it out of his own pocket; he has every inducement to raise maximum crops, because the larger the yield the greater his share. Lady Carlisle, having an interest in every crop and in all stock sold, has every inducement to encourage her partner. It is easy to see that any improvement of a permanent character would result in an increase of produce which each partner would share.

In Northumberland I am farming on the profit-sharing system 3,765 acres—1,290 permanent pasture, 2,475 arable. This

---

is called the "métayer"), the products being shared between the two according to arrangements previously agreed upon. Earl Cathcart, in his memoir of Sir Harry Meysey Thompson in Vol. X. of the Journal (1874), happily described métayage as the "half-holder" system.

In reply to an inquiry, Mons. J. Laverrière, the accomplished librarian of the Société Nationale d'Agriculture de France (the French Academy of Agriculture), writes: "The system known as *métayage* is as old as the world, having been practised by the Romans. It is still frequent in Italy, Spain, and France. But if I mistake not, it is only in the latter country that an endeavour has been made by new combinations to revive and modernise it. Attempts in this direction have been made during the last twenty or thirty years, which have caused some stir. It is this, no doubt, which has given persons who are not *au courant* with the history of métayage the impression that it had to do with co-operative agriculture, or co-operative agricultural association in production, of the same kind as the industrial co-operative associations of production as established in England and some other countries. Attacked in France by the partisans of farm tenancies at a rent, métayage has nevertheless constantly found enthusiastic defenders, even amongst our most illustrious agriculturists. Thus the Count de Gasparin, one of our agriculturists as remarkable for his science as for his technical experience, has devoted to métayage a special work published about 1830. This can still, notwithstanding its age, be consulted with profit. M. Leonce de Lavergne examined this method of cultivation in his "Rural Economy of France," the complement of his "Rural Economy of England"; and M. Emile de Laveleye, the eminent Belgian economist, has also studied the subject. But it is especially the favourable results obtained by application of this system to his domain at Theneuille (Allier) by M. Louis Bignon, that have latterly restored to métayage a certain amount of popularity. Some interesting particulars are given in this subject in a paper in the Memoirs of the Société Nationale d'Agriculture de France for 1870-71. A further reference is made, in the Memoirs for 1875, to métayage in the South of France. Métayage is practised in Brittany, in the Beaujolais vineyards, in the ordinary cultivation of the Dombes (Ain), and in the pastures of Limousin. It is a system which has a certain elasticity, since it is applied in the most diverse circumstances, and in localities so far distant from one another as the places named above."—Ed.

acreage is divided between three farms situated in different parts of the county. One farm—Chevington Moor, of 403 acres—is a heavy clay farm, thrown upon my hands in 1888 like a squeezed orange, with all the fertility sucked out of it by bad and penurious farming. Through generous applications of Newcastle Corporation manure, this farm, which has not yet made a profit, is gradually coming round; and I hope soon to be able to show a balance-sheet which will be as satisfactory to the workers as to me.

In the year 1886 I applied the profit-sharing principle to the home farm at Howick; since which time I have been able, on three occasions, to distribute among the employés a bonus of sixpence in the pound on wages earned, as their share of the profits, and the prospects of next year's balance-sheet are, at this moment, encouraging.

In the same year I also entered into the occupation of East Learmouth Farm, which is popularly known in Northumberland as "The Profit-Sharing Farm," and which has been the subject in the local press of considerable recent controversy. The outgoing tenant had insisted, as a condition of continuing the occupation of the farm, upon an increased reduction of rent, over and above the reduction of 8s. 8d. an acre (from 42s. 7d. to 33s. 11d.) to which the rent had fallen when he entered the farm in 1882. His request not having been acceded to, the management of the farm came into my hands. It is a farm of 821 acres, 122 acres of which are permanent pasture and the balance arable.

The nature of the soil is a good loam, and it enjoys the reputation of being one of the best turnip and barley farms in Northumberland. The knowledge of what had been done at Ralahine and in the German experiments to which I have already referred, coupled with a profound disbelief in the soundness of the "three acres and a cow" proposals, caused me to gladly take advantage of the opportunity, which the occupation of East Learmouth farm afforded me, of making a good practical experiment of the way in which the profit-sharing principle might operate to the advantage of the agricultural labourer.

My first desire was, to establish the principle upon a basis which, from its obvious fairness and from the advantage which it offered to both employer and employed, might tempt other employers to apply it to their respective industries. It seemed to me that the profit-sharing principle, to be absolutely fair and unassailable from every quarter—whether capitalist or labourer,—should demand that the net profits which might remain, after labour had received its market rate of wages and capital its

fixed rate of interest, and other necessary deductions for depreciation and reserve had been made, should be divided between labour and capital in proportion to the money value of the services rendered by each—*i.e.*, if an industry were to pay 1,000*l.* to the labourers for the use of their labour, and 500*l.* to the capitalist for the use of his capital, then two-thirds of the net profits should go to labour and one-third to capital. This principle, which I observe has been adopted by Mr. Boyd Kinnear, was laid down by the late Monsieur Godin of Guise as one which was demanded by expediency no less than by justice.

The only consideration which prevented my applying to East Learnmouth this principle of division, which still appears to me to be the fairest principle which has yet been formulated, was that in this particular instance of Learnmouth Farm the proportions would have been the other way, since, inasmuch as the farm pays twice as much in the shape of rent and interest as it does in the shape of wages, only one-third of the net profits would have been available for the employés. I was afraid that the prospects of advantage held out to them by this proportion would have appeared so small that they would not have had sufficient inducement to co-operate with me in the way I wished in an endeavour to make the experiment a success.

So I thought the best way to accustom them to the principle of profit-sharing, and to make them realise its advantages, would be to adopt the simplest possible form of division, and, after the fixed charges of rent and interest had been met and a certain percentage of profits had been paid to a reserve fund, to divide any surplus profits that might remain in equal proportions between them and me, the half going to labour being divided among them in proportion to the wages earned by each.

Acting upon this principle, I was able to give to the workers for the year ending May 12, 1888, a bonus of 1*s.* in the pound, or an increase of 5 per cent. upon their wages. For the year ending May 12, 1889, the profits only amounted to 29*l.*, which sum was placed to reserve, being too small to admit of an appreciable bonus being distributed. For the year ending May 12, 1890, the workers received a bonus of 1*s.* 1½*d.* in the pound, or an increase upon their wages of 5½ per cent.

For the year ending May 12, 1891, the profits amounted to 191*l.* In the division of this sum I adopted a somewhat different plan. Before I proceeded to the division of profits between labour and capital, I took 25 per cent., or 47*l.* 18*s.* 6*d.*, and added it to the reserve-fund. I next put aside another 25 per cent., or 47*l.* 18*s.* 6*d.*, for the reward of management. This

was only fair, as there was no question of a doubt about the fact that the satisfactory condition of the farm was due to the admirable management of the bailiff, Mr. Fox. I accordingly gave two-thirds of the sum allotted to the management, or 31*l.* 19*s.*, to Mr. Fox, the manager, and divided the remaining one-third, viz., 15*l.* 19*s.* 6*d.*, in equal proportions between the steward and the herd.

I then proceeded, having placed 25 per cent. to reserve and 25 per cent. to management, to divide the remainder in equal halves between labour and capital. 47*l.* 18*s.* 6*d.* went in this way to capital as increase of rent, and 47*l.* 18*s.* 6*d.* to the labourers as increase of wages, thus enabling the labourers to receive for the year ending May 12, 1891, a sum of 1*s.* 3*d.* on every pound earned, or an addition to wages of 6 $\frac{1}{4}$  per cent.

The net results of my five years' occupation of East Learnmouth, from May, 1886, to May, 1891—a period which has experienced one very bad harvest (that, namely, of 1888) and during which the range of the average price of wheat, barley, and oats has been lower than in any similar period since 1790—are as follows:—

The rent of 1,431*l.* and interest on capital at the rate of 4 per cent. have been paid with unfailing regularity; 163*l.* 5*s.* 11*d.* has been given in bonuses to the employés on the farm, 148*l.* 2*s.* 7*d.* has been paid as additional interest on capital, and a reserve fund has been formed which at the present time amounts to 182*l.* 8*s.* 4 $\frac{1}{2}$ *d.*

This Reserve Fund exists for the benefit of the farm:

1. It will serve as a fund from which can be drawn in bad years the sum required to make up the annual charges of rent and interest.
2. It will serve as a fund from which can be drawn superannuation allowances for aged and disabled servants who have grown old and feeble in the service of the farm.
3. It will also serve as a fund, if the continued success of the farm allows its resources to increase, from which money can be drawn when it is required for any object which seeks to promote the general well-being of the employés on the farm.

The legal position of the labourers towards me is the same as that of every other agricultural labourer towards his employer. They have no voice in the management of the farm, and no power to interfere. But while I do not allow them to interfere in any way with the management, the fact that I employ Mr. Cleghorn—a most excellent accountant and the son-in-law of



the manager, and the son and brother of other employés on the farm—to keep the books of the farm, and to draw up the annual balance-sheets, is accepted by them as perfect and sufficient security that their interests are properly safe-guarded.

I pay them the current wages of the market, and reserve to myself the right to withhold from them the bonus in the event of misconduct, and to dismiss them from the farm at the end of every year. I have informed them that this is a right which I will unsparingly exercise whenever I am convinced that any of the hands have, by misconduct, or by careless and slovenly work, proved themselves undeserving of the privileges which are only intended for those who show by their conduct that they are worthy to possess them.

The working of this experiment has been so satisfactory that I have added to East Learmouth the adjoining farm of West Learmouth, with an area of 942 acres; and from May 12 last these combined farms have been worked as one undertaking.

It should be added that if the gross profits for any one year should fail to pay rent and interest on capital, the deficit must be made good out of the net profits of succeeding years before any bonus can be distributed.

It now remains to explain shortly the *à priori* reasons why, even if there were no reassuring examples, such as those to which I have referred, it is desirable that landowners and farmers should apply the profit-sharing principle to the cultivation of their farms. Its great virtue consists in this, that it utilises a valuable waste human product, which in that part of England with which I am best acquainted is at present absolutely lost.

It was well said by Mr. Marshall, in his inaugural address at the Co-operative Congress at Ipswich in 1887, that great as were the fortunes which had been realised out of the waste products of gas-works and soda-works, in the world's history there had been one waste product so much more important than all the others, that it had the right to be called *the* waste product. He was referring to the unused abilities of the working-classes—to the latent, undeveloped, choked-up, and wasted faculties for better work, which lie dormant and unused for lack of opportunity, or of interest to awaken them and bring them into life.

Those who are conversant with the inner life of the Northumbrian hind are aware that one most unfortunate result of the yearly labour contracts which obtain in Northumberland is that the great majority of the agricultural labourers take no interest in the business of their lives. Their only object when

engaged upon their work is, to quote the language of one of my own employés, "to fetch the night."

There is, of course, that incentive to good work which comes with the hope of rising in his profession and of becoming a bailiff; but that is an incentive which appeals only to those who are above the average of their fellows in character and efficiency. There is also the motive which causes every self-respecting man to take an interest in his work—namely, that of satisfying his own conscience; but the men who give extra attention to their work simply to satisfy their own high standard of duty are, I fear, still in a very small minority, and I am speaking of the great majority when I say, that under the present system which prevails generally over Northumberland and the Lothians, there is no sufficient incentive to cause a man to put brains and energy into his work.

The relation between the amount of his wages and the prosperity of the farm is so faint and remote as not to weigh with him at all. It matters not to him whether the harvest be good or bad; it makes no difference to his wage. So long as his employer's solvency is assured, it is no concern of his whether the farm prospers or not. If he likes his house, his employer, and his fellow-labourers, and he wishes to remain on the farm, there is the natural inducement to work well enough not to be turned off at the end of the year. But this inducement cannot be said to be very powerful, for even when young men do not prefer, after four or five years of full hind's work, to leave agriculture for the more stimulating company and excitement of the towns, families seem to like the change and variety which are provided by migrating from one farm to another every second or third year. The consequence is that there is little or no inducement provided by the healthy stimulus of self-interest for the agricultural labourers to concern themselves about the efficiency of their labour.

The fact that the success or failure of the farm on which a hind is employed makes not one atom of difference to him must have a most seriously depressing influence upon him. It must tend to make him profoundly indifferent as to the character of his work. Instead of his faculties being constantly sharpened by the spur of self-interest, they are not called into play. The brain, for lack of exercise, loses half its power, the bright face in time assumes the expression of settled vacancy, the arm grows heavy and the step slow, and gradually the hind loses all the glowing promise of his boyhood, as he develops the wooden inefficiency of the automaton, and the qualities which have earned for him the sobriquet of "Hodge."

This is the great fact to which landowners and farmers should turn their attention. The greatness of loss occasioned by the waste of brains and energy should urge them to inquire whether there do not exist methods by which it can be saved.

The common criticism in Northumberland of the Learmouth scheme is that while a landowner may be able to give a bonus to his labourers, that act of generosity is not within the farmer's reach. These critics have failed, through want of imagination, or want of thinking, to grasp the fact that just as the application of manure to the soil brings into life and makes active the dormant powers of the land, so the effect of the profit-sharing principle, when it is so applied as to cause the labourers to realise that half of the profits netted after a certain limit has been reached belongs to them, is to save the waste of human thought and energy, and thereby to create a fund out of which the bonus can be paid.

Those who have a practical acquaintance with the details of farming know from painful experience how serious is the loss which is caused to a farm through careless and indifferent labour. I have heard the remark from more than one farmer when talking of his labourers: "If the gateposts were 100 yards apart, they would run up their carts against one of them, sure enough." This example may be taken as an instance of the loss which is occasioned in all the operations of the farm by that want of care which is caused by lack of interest. Where the heart is not in the work, there will be daily waste and daily loss of opportunity. Where the heart is in the work—because self-interest is in it also—we have the greatest security that human ingenuity can provide, that every man will be a bailiff unto himself.

It is, of course, difficult to assess the value of the difference to a farmer between a good workman and a bad one. But it is evident that loss and injury to the farmer follow the trail of the careless man from morning until eve. Take an illustration from the field. In ploughing the lea to prepare an even and proper seed-bed for the oat crop, as is the custom in the North, a bad or careless ploughman may be the means of causing loss—at the present price of oats—of from 1*l.* to 2*l.* per acre. If the land is ploughed correctly, each furrow slice will be of uniform thickness, and lie easily upon the other at the same uniform angle, "presenting crests in the best possible position for the action of the harrow."

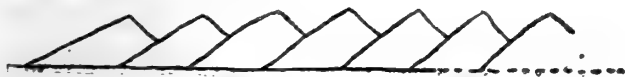

If the land be ploughed in such a way as to give this result—a task which requires a skilled hand, a correct eye, and a thorough command over the team of horses—an even seed-bed will be secured, no seed will be lost, and the crop will germinate and ripen all at the same time.

If, however, by bad and careless ploughing, the ribbons of soil turned over by the plough vary in their thickness, and in the angles in which they fall upon each other, then much



seed corn is lost by falling in between the ridges and becoming buried, and the seed which is not lost falling upon an uneven seed-bed germinates and ripens irregularly, with the result that the crop will contain a large proportion of light and unprofitable corn.

Agricultural experts calculate that in this one farming operation alone, a careless and uninterested workman may cause loss to the farmer at the rate of from ten to twelve bushels an acre. Again, instead of cutting the furrow clean out (thus,



in the bottom and ploughing at an even depth throughout, a careless hind may, by raising the right hand "stilt" for greater ease, cause the bottoms of the furrows to

appear thus , with the result that on

the right-hand side of every furrow the soil may only be 3 in. or 4 in. deep instead of 6 in. or 7 in., and by not keeping the depth even throughout the length of the furrow, it will show in this way:



Again, in sowing corn, an unskilful man may scatter the seed in patches instead of evenly, and by not paying attention may overlap when walking up and down the ridges. The corn will come up too thin in some places and too thick in others. Where too thick the straw will be weak and be more liable to lodge, and the grain will in all probability be inferior in quality.

It is unnecessary to follow the corn, crop through all its stages, but it would be easy to show that at every point loss to the farmer is the consequence of careless and indifferent labour. The careless man will break his plough and smash his reaper, causing expense to the farmer and stoppage to the tillage operations at a moment when minutes, owing to the changeableness

of the weather, have a positively golden value, under circumstances where a careful hand would have gone on the "even tenour of his way" without a break or check.

And in the stackyard, as in the field, the same difference between a good and bad worker will be easily observed. The good stacker will keep his stack well filled in the centre, and will give his sheaves a slope up towards the centre, by doing which he will make the stack perfectly water-tight, so that it will, even without a covering, point the rain which may fall upon it as efficiently as any umbrella. But to raise a stack like this requires care and skill and trouble. A lazy and careless stacker finds it easier to lay his sheaves in an almost horizontal position; when the stack settles, the slope resembles the gradient of the saucer not of the umbrella—the trend is downwards from the circumference to the centre, not upwards: and the loss is of course enormous.

In the management of animals, even those who know nothing of farming operations will be aware that profit or loss will depend in great measure upon the patience and care of the man in charge. Every farmer knows of some valuable animal which has been lost simply through the idle carelessness of the hind. After a hot piece of work a favourite mare has been left to "starve" too long in some position exposed to the north-east wind, with the result that she dies of inflammation, and straight fly 70*l.* to 80*l.* out of the pocket of the farmer.

At Howick, in the course of a not very long period, four or five horses which have been employed in dragging fallen timber out of the plantations have been lost through the carelessness of the hinds, who neglected to make them fast, and thus allowed them to fill their stomachs with the poisonous yew. The rule, which now exists at Howick, that any man who loses a horse through this cause, will also lose his bonus, will, it is hoped, prevent a repetition of a similar calamity.

Enough has now been said to show how great is the loss that may be sustained by a farmer, who is served by unintelligent and careless labour. But while it is impossible to estimate the damage done to a farmer by a careless man, or to measure the increased value of the work of a labourer who realizes that his interest is bound up in the farm, over that of a labourer who has no interest in the produce of his industry, we have some guide in the experience of large employers as to the difference in the value of the labour of a man paid by the piece and of a man paid by time.

Sir James Kitson, speaking of mechanics, says: "The man paid by the piece will do one-third as much—or 33 per cent.

more—than the man paid by time.” Sir William Gray, ship-builder at West Hartlepool, says: “While a rivetter’s day wage is 6s. 8d., he can earn 11s. when paid by piece.” And Mr. James Laing, of Sunderland, also speaking of rivetters, gives it as his opinion that the man paid by the piece is 70 per cent. more efficient than the man paid by time.

According to the census of 1881, there were in the county of Northumberland at that time 11,710 agricultural labourers, and in the whole of England and Wales, 870,798.

Supposing it were possible to apply to the farms of Northumberland some principle which, when applied to the mechanical and shipbuilding industries, increases the efficiency of labour from 33 per cent. to 70 per cent., it will be seen at a glance what is lost to agriculture by the want of such a system. Say that we can increase the efficiency of the labourer, by admitting him to a share in the profits, not by 70 or 33 per cent., but only by a modest 10 per cent., and we at once put upon the soil of Northumberland an increased force equal to 1,170 men, and on the land of England and Wales an additional army of 87,000 labourers!

There is another feature to which I must shortly refer, because it supplies interesting evidence of the manner in which, when once a right principle is applied to industrial enterprise, it harmonises in ways totally unexpected with existing social arrangements. It is well known that the effect of modern legislation has been to put into the hands of those householders who pay no rates and few taxes the power of rating the owners to any extent they please. When one class levies the taxes and another pays them, all the conditions are at hand for the production of injustice, turmoil, and discontent.

The profit-sharing principle helps to put this right. On those farms where the system is applied, the labourers are as closely interested as any owner in the economy of local administration, or, rather, I should say, more deeply interested, inasmuch as the pressure of the rate falls more heavily upon them in proportion to their income than it does upon men of greater means. This will be evident when I point out that if no rates had been levied off East Learmouth, the profits for last year would have been 50*l.* 6*s.* 1*d.* higher than they were. There would have been:—

12*l.* 11*s.* 6*d.* more to reserve.

12*l.* 11*s.* 6*d.* more to management.

12*l.* 11*s.* 6*d.* more to capital.

12*l.* 11*s.* 6*d.* more to labour.

In the distribution of profits, labour would have been entitled to 60*l.* 10*s.* 1*d.* instead of 47*l.* 18*s.* 7*d.*, and each hind,

instead of receiving a total, including bonus and wage, of 53*l.* 17*s.* 2*d.*, would have received 54*l.* 14*s.* 0*d.*—an addition of 16*s.* 10*d.* That is to say, the aforesaid hind paid the local rates a sum of 16*s.* 10*d.*, equal to about 4*d.* in the pound.

Supposing the local rates had been as high during the year ending May 12, 1891, as they were the first year after I entered East Learmouth farm, we should have been called upon to pay to the rate collector 45*l.* more than we have actually paid. In that case the hind in question would have paid an additional 14*s.* 11*d.*, or 1*l.* 11*s.* 9*d.* in all, to the local rates, equal to 7*d.* per pound upon his wage of 54*l.* 14*s.*

I have now brought forward sufficient evidence of the success which has attended past and present experiments in the application of the profit-sharing principle to agriculture to induce some landowners, I trust, to make further experiments on their own estates. It is for them to give the lead. There is nothing to prevent tenant-farmers from applying the principle with equal success to their own farms, but it is unreasonable to expect that they will be the first to show the way. The principle requires extremely accurate bookkeeping, and I regret to think that the practice of scientific and accurate bookkeeping is among them the exception and not the rule. I am glad, however, to believe that the number of farmers who keep careful accounts of all their farming operations is growing steadily year by year. It is to be hoped that some of them, when a few more experiments have proved that the profit-sharing system is as beneficial to the employer as to the labourer, will be tempted to put the principle into operation on their own holdings: but at present they regard, and for some little time to come we must expect that they will regard, a profit-sharing plan as something which is not for them. Even if they felt so inclined, they might be deterred from adopting it by the not unnatural dread that their landlords, knowing what profit they make, might be tempted to increase the rent.

Apart from this consideration, however, the tenant-farmer argues that he is in a position of disadvantage compared with the landowner in applying this principle. The landowner who farms his own land can easily obtain what capital is required at 3½ per cent. to 4 per cent., because in his case the interest on the borrowed capital is a first charge on the profits of the farm—*e.g.*, at East Learmouth the rent paid annually is 1,430*l.*, while the charge for interest on the capital invested at 4 per cent. amounts to only 200*l.* The security is obviously first rate: it would not be easy to find a better. Money can

be obtained on mortgage at  $3\frac{1}{2}$  per cent. where there is a 50 per cent. margin. Here the cover is over 700 per cent. A fairly solvent landowner, therefore, should have no difficulty in borrowing for this purpose what money he requires at exceptionally low rates of interest. But a farmer who has to pay his rent before he receives any interest on the capital invested in the farm is very differently situated.

The working capital of the farm is now degraded from an exceptionally safe preferred position, to one that is highly risky, and when the character of the risk is considered, no one will dispute the right of the tenant-farmer to claim at least 10 per cent. But just as the tenant is entitled to receive 10 per cent. upon his capital, where the landowner is content to receive 4 per cent., because the tenant's interest is a deferred and not a preferential charge, so the landowner, when he takes a farm in hand, ought to receive a higher rent than he can obtain from a tenant in order to compensate him for the extra risk he runs.

The reason why landowners, as a rule, let their estates to tenant-farmers, rather than farm them through bailiffs, is that they prefer the luxury of a fixed and regular income of a moderate amount, to the prospect of a higher income which in exceptionally bad years may disappear altogether.

The advantages which appear to dwell in the profit-sharing system as applied to agriculture may now be summed up.

As far as the landowner is concerned, the facts I have quoted show the advantage to him is no small one. Speaking from the point of view of a landowner, I can say that, apart from the great satisfaction which has accompanied the successful working out of a progressive theory, my occupation of East Learmouth has added immensely to the pleasures of proprietorship, the rights of which I now enjoy far more fully than when the farm was leased to another.

I have increased my income; I possess undivided sporting rights over the farm; I have a most excellent and comfortable farm-house, which I can occupy or let as I please; and last, but not least, I feel absolutely secure against any possibilities which future legislation, based on the lines of the Irish Land Acts, may have in store for English landowners.

The advantages to the labourer are no less evident. The fact that the labourer is trusted, and welcomed as a partner in the profits of the farm, in itself lends a new complexion to all the various duties which go to make up his working day. He is conscious that a greater dignity attaches to his position,



that his status is improved, and as a consequence his labour is invested with an attraction it did not formerly possess.

Neither can it be doubted that the knowledge that he and his fellow-workers will share the benefit which the farm may derive from his forethought, his energy, and his skill helps to lift from off his work some of the burden which weighed it down when he reflected that, however well and efficiently he might serve his employer, no benefit would accrue to his fellow-workers or himself.

In short, where the profit-sharing principle is successfully applied, it lightens the task, it increases the wage, it gives hope, it stimulates the faculties, and it frees the worker from that paralysing atrophy which sooner or later asserts its sway over men who have no interest in the produce of their industry, and to escape from the fatal influence of which so many of the best of the young hinds are leaving agriculture for the towns.

And if the profit-sharing system helps, by increasing the efficiency of agricultural labour, to increase the gross produce and the net profits of the farm ; if, further, it tends to impress the agricultural labourer with a greater sense of the duties and responsibilities of citizenship by making him realise more vividly his position as a ratepayer ; if, too, it helps to reconcile the agricultural labourer to his life, and thus do something, however little, to check the growing desire for employment in the towns, who can measure the extent and volume of the benefit which the State will derive from an enlarged application of the profit-sharing principle to the agriculture of this country ?

I am aware that the form in which the profit-sharing principle is applied to the farms which have been the subjects of my reference is not the highest nor the final form. We may hope that the day will come when the labourers will be not only partners in the profits, but partners in the management—when bodies of associated agricultural labourers will be the owners of the land on which they work and of the capital which gives them employment. But *Natura non facit saltum*: we go most quickly along the road of progress by being content to make sure of one step at a time. The first step forwards from the present state of things is to invite labour to a partnership in the profits. When the right time comes, labour will be admitted to a partnership in the management as well.

ALBERT GREY.

---

## THE DUTCH AGRICULTURAL COLONIES.

CERTAIN advanced social reformers have lately been advocating the employment of the destitute and criminal classes in farming operations, apparently under the impression that the "submerged tenth" will not only become expert agriculturists, but will make the farm on which they are engaged a paying concern. The system is by no means a novel one in Continental countries, and in Holland especially it has had an extended trial of nearly three-quarters of a century. An opportunity having occurred of paying a visit to the agricultural colonies at Frederiksoord, in that country, I made last September a somewhat detailed and careful inspection of them, the results of which are summarised in the following pages.

There is no poor-rate in the Netherlands, and the State does not interfere in the matter, except when no relief is to be had from private charity. In such a case, the pauper must be supported by the commune where he is living; but the communes usually grant subsidies to the private societies *de bienfaisance* which exist in all parts of the country, and which contribute the only organisation existing in Holland for the relief of the poor and destitute. The charitable institutions of Amsterdam are world-famed. They are upwards of a hundred in number, destined for the reception of sick, aged, and indigent persons, lunatics, foundlings, widows, &c., and are all almost entirely supported by voluntary contributions. One such society, the *Maatschappij tot Nut van't Algemeen*, whose object is the education and moral culture of the lower classes, has 16,000 members paying about half a guinea per annum, and its sphere of operations extends over the whole kingdom of Holland. Another society is the *Maatschappij van Weldadigheid* (Benevolent Society), which is of especial agricultural interest, because it seeks to prevent pauperism by providing rural training and employment for destitute but able-bodied and deserving persons.

The estates owned by this society are situated near Steenwijk, on the heath-land on the borders of the provinces of Drenthe, Friesland, and Overijssel. After the conclusion of the great war in 1815, there was in Holland, as in other parts of Europe, great distress and misery; and an official report of the Dutch Minister of the Interior, dated December 28, 1816, estimated the number of paupers in the northern provinces at over 190,000. In certain towns a third of the population received relief. General John van den Bosch, a Dutch officer

who had spent some years in the Indies, conceived the idea of employing the poor in fertilising and cultivating waste lands, on a system with which he had become familiar in Java, upon a Chinese colony near to his own farm; and having obtained the support of several distinguished persons, Prince Frederick at their head, he founded the Benevolent Society in 1818. The annual subscription of members was fixed at 2*fl.* 60*c.* (about 4*s.* 4*d.*), in order to secure as wide a basis as possible. Within twelve months the society had more than 20,000 members, and a beginning of its programme was made by the purchase of 1,200 acres of heath-land, which were formed into a colony, called Frederiksoord, after the president of the Society. On this colony 52 families were installed in as many houses, with about six acres of land attached to each. A second colony with 50 houses was opened in January, 1820, the name of Frederiksoord being extended to embrace both; and later in the same year a third colony, as large as the other two together, was opened, with the title of Willemsoord, after the then Prince of Orange (afterwards King William II.) By the end of 1821 four new colonies were formed, and the name of Wilhelmina's oord, after the widow of Prince William V., was given to two of them.

Shortly afterwards the Society founded, in addition to the free colonies above named, two beggar colonies at Ommerschans and Veenhuizen, which it attempted to carry on in conjunction with the others. The subsequent history of the Society is too complicated to be told here,<sup>1</sup> but some of its difficulties are indicated in the following account of its operations by the present Director, Dr. Löhnis:—

The principal aim was to ameliorate the condition of the working-classes by procuring them permanent work, as far as possible according to their individual capabilities. Agriculture was the chief means of giving employment. The poor families who were sent to the colonies came out of the towns, and were therefore unacquainted with farm work; but it was supposed that they could learn it in a few years, and that they would be able to supply their own wants afterwards. The founder of the Benevolent Society, enabled by voluntary subscriptions, bought a large tract of waste land in the northern part of Holland. Several hundreds of small farm-houses were built, and it was supposed that the families who were placed on the farms would fertilise and cultivate their  $6\frac{1}{4}$  acres of land, with the aid of an annual grant of money for a period of about five years, and that they could subsequently live on the produce of the land. It will thus be

<sup>1</sup> A very clear and interesting account of the causes which led up to the Society's financial crisis of 1859 will be found in Mr. H. G. Willink's Report of 1889 to the Charity Organisation Society on "The Dutch Home Labour Colonies." (Kegan Paul, Trench & Co. Price 1*s.* 6*d.*) Some valuable facts about the colony are also given in Pasteur Robin's article, *Des Colonies Libres de Travailleurs en Hollande et en Allemagne.* (Bulletin de la Société Générale des Prisons, November 1886, p. 938. Paris: Imp. Chaix.)

seen that the idea was to make agriculturists of the poor of the towns, and in the meantime to cultivate the waste land. It was, however, soon apparent that these families could not so speedily acquire a knowledge of agricultural operations, nor subsist upon the produce of their farms; and this miscalculation resulted in great pecuniary difficulties. Several corporations and municipalities, and not least the Government and members of the Royal family, endeavoured to save the Society. The Government contracted with the Society that vagrants should be placed in the colonies, and for this purpose large establishments were erected in the reformatory colonies—Veenhuizen and Ommerschans. Several thousands of vagrants were sent to these new colonies, a certain sum being paid for each individual. In consequence of the bad results of farming, manufacturing industries were commenced. The Government entrusted the Society with large orders for cotton goods, at high prices; and in 1840 about 1,200 or 1,500 persons were employed in weaving. Notwithstanding all these efforts, the affairs of the Society became more and more involved, and in 1859 a composition was made with the creditors. Since that time the reformatory colonies have been in the hands of the State, and the free colonies have been re-organised, and still remain in the hands of the Benevolent Society. Six large farms of from 125 to 150 acres were formed, new manufactories were introduced, the administration was simplified, and considerable attention was devoted to the growth of woodland.

Under the re-organisation of 1859, the Government took over the whole of both the beggar colonies, land, buildings, and all, as a going concern, and relieved the Society of about 460,000*l.* of debt. Since then the Society has continued without hindrance its original function of providing agricultural employment for destitute but deserving persons. It appears now to be in a very flourishing condition, although the serious diminution in the number of members (at the date of the last report there were only 4,113 subscribers) cripples its usefulness.

Everything is done in Holland by district committees (*afdeelingen*), of which for the Frederiksoord Benevolent Society there are fifty-two, each with a chairman, secretary, and treasurer. The committees recommend families for admission to the colony, the final selection being made by the Central Administration, consisting of five honorary members and a paid director, who resides at Frederiksoord. Each of the 4,000 members of the Society pays an annual subscription of 2*fl.* 60*c.* (4*s.* 4*d.*), and the district from which a labourer is selected for the privileges of the colony has to pay 142*l.* (1,700*fl.*) for the expenses of his installation. None but destitute cases are admissible; generally they are without relations. An acquaintance with farm work, or with some trade or business, is indispensable. Single persons are not ineligible for admission, but families are preferred. A normal household consists of six persons, four being children. If a family selected has less than four children the vacancies may be filled up by boarders. Boarders (generally children) are also placed with families

having more than four children, where such a course appears desirable.

The principle of the Society appears always to have been to set before the colonist the prospect of becoming the absolute master (within the limits of the regulations) of the land which he occupies; and with the object of encouraging him to a better and more profitable cultivation of the soil, it offers to him the inducement of becoming a "free farmer" after a certain period of earnest work. At first, however, he is a mere labourer in the service of the Society on one of the six large farms which it manages. He is paid at fixed rates for his work, the wages, which are paid every Thursday, amounting to 1s. 2d. per day in the summer and 10d. in winter. Most of the work is done by the piece; and in these cases, of course, more money can be earned. Permission is often given to the labourers to seek employment outside the colonies, but they are entitled to obtain work all the year round. In the winter it is sometimes difficult to procure them useful occupation, and therefore, in addition to the six farms, several basket-making, mat-making, and weaving establishments have been erected.

The children are required to attend school, and if the father cannot earn enough for the wants of his family he receives for some years a weekly supply of food, clothes, or money. The labourers pay 7d. a week for the cottage allotted to them by the colony, about a halfpenny (three cents) for each member of the family for medical attendance, 2d. each to the clothing fund, and 10 per cent. of the whole wages to a reserve fund. For example: A family consists of man, wife, and four children. The man earns 6s. per week, and the wife and children, by basket-making, sewing, &c., 3s., making a total of 9s. They pay—

	s.	d.	
For rent of cottage . . . . .	0	7	}
For medical attendance, six persons at 3 cents. . . . .	0	3½	
Clothing fund, six persons at 2d. . . . .	1	0	
Reserve fund, 10 per cent. of 9s. (say) . . . . .	0	11	
			2 9½

Thus he has in hand 9s. less 2s. 9½d. = 6s. 2½d. per week for food and other requirements.

Every three months the family can get clothes for the money they have in the clothing fund, and every month they can draw out their money in the reserve fund.

After from two to five years' work, the labourer may, if industrious and well-behaved, be promoted to be a free farmer (*vrij boer*)—i.e., to become a tenant of one of the Society's small

farms without any obligation to work for the Society itself. This is a privilege ardently desired and diligently worked for.

There are 225 of the small farms, each consisting of  $2\frac{1}{2}$  hectares (about  $6\frac{1}{4}$  acres) and a cottage. The rent, which is fixed by the Society, varies from about 3*l.* to 6*l.* a year, according to the quality of the soil. The actual freehold of the farm cannot be acquired by the *vrij boer*, but he remains the tenant of it, with good behaviour, for the whole of his life.

Upon becoming a free farmer the labourer receives from the Society a cow, manure worth about 7*l.*, four bushels of potatoes for planting, a ton of hay, and a ton of straw, the cost of the cow and manure being repayable by a small annual charge. The free farmer is obliged to insure the cow in the Mutual Insurance Company of the colony, and has to pay 10*s.* 10*d.* per annum for medical attendance. Otherwise he works the farm for his own benefit and as he chooses, though under the general supervision of the Director, and subject to the restriction that hay, straw, and manure must not be sold away from the colony. He may also work for wages outside the colony if he likes; and in summer some go into Friesland for the hay-making. The rents are generally well paid, and whilst the lazy and improvident are not encouraged, the administration is as lenient as possible with regard to arrears.

The dwellings and allotments of the farmer and labourer colonists are erected upon a uniform plan, very much upon the original pattern. Each allotment is laid out in a rectangle, having the house towards the road at one end, and the other reaching 50 feet into the allotment. The cottages are all built of brick, with glazed windows in the gables; and, as is customary in Holland, attached to the opposite gable is a wooden erection of the same breadth and height, under a prolongation of the same roof, and from 20 to 30 feet long. The wooden annexe contains a place in one corner for one or two cows, and serves both as a lobby to the house and a general store or barn. The houses consist of one living-room on the ground floor, about 15 or 16 feet square, fitted with box beds, and floored with tile or brick, with an attic over it of the same size. Nearly all the houses are now provided with a second small room floored with timber.

Around each labourer's cottage is from a half to one acre of land, on which to cultivate potatoes and vegetables for the use of the family. The colony gives the family on arrival a sheep, which is kept for its milk. The sheep is usually stabled in the cowhouse, but when the weather is fine it is tethered to a rope, and allowed to graze on a small piece of grass-land in the labourer's garden, or along the roads.

The food and habits of life both of the free farmers and the labourers are severely simple. The poorest eat little but rye-bread, potatoes, and milk. Those better off have eggs, bacon, milk, and cheese. Beer is not forbidden, but is not much drunk, as it is not sold in the colony. The colonists are not required to don any particular kind of dress; they can wear what clothing they like, and buy it where they please. They appear to be comfortable and contented, and their cottages are very clean and tidy, though this is the almost universal rule in Holland.

Besides agricultural occupations, work is found for the colonists in the Society's workshops, which also afford employment in the winter time, when there is less to do out of doors, and it is difficult to keep the hands employed.

There are a forge and a carpenter's shop, where several lads are usually placed as apprentices, as well as weaving-sheds, and two basket-factories of considerable size (founded in 1873). Quantities of coffee-bags, sacks, coverings for cows' backs (used almost universally in Holland in the cold weather, and called "enveloppen"), and many other jute and coarse cotton fabrics are manufactured. Mats and baskets of all sizes and patterns are made; and of late years a considerable industry has sprung up in the construction out of osier and bamboo of a great variety of ornamental articles, which are sent all over Holland, and even abroad.

An average of 50 workpeople are employed in the basket trade. The goods sold annually amount to 1,600*l.* The osier used is bought from outside, as numerous experiments have shown that the cultivation on the estate does not give good results. There is also a printing-office at Steenwijk, where a certain number of lads are employed.

The Society attaches the greatest importance to raising the condition of the children of the colonists, in order that they may fit themselves for careers of usefulness outside the colony. The cost of the ordinary schools on the estate is defrayed by the Government as a part of the general scheme of free education in the Netherlands. There are five national schools (*rijks-scholen*), with 15 teachers, where the usual curriculum is taught, besides two carpentry and drawing schools for boys, and four schools for sewing and knitting for the girls. A recent important addition to the educational facilities at the colony has been the establishment of three large, handsome, and well-appointed schools for agriculture, horticulture, and forestry, to which the best of the pupils can proceed after they have gone through the ordinary schools. For these schools the colony is indebted to the generosity of the late Major F. U. L. von Swieten. The

first of the three was founded in 1884, and they are now attended by about 40 lads. For the families of colonists the teaching at these schools is wholly gratuitous, but strangers are also admitted, and pay for their instruction and lodging 24*l.* per annum.

The population of the colonies numbers about 1,800 persons, consisting of 90 families of labourers, 220 free farmers, and 120 children and orphans boarding with the different families.

There are two Protestant churches and one Roman Catholic church on the estate, and the pastors of each are suitably provided for. The medical service is under the charge of a doctor living at Frederiksoord. No public-house is allowed, and drunkenness is severely punished. A weekly court of justice is held, presided over by the Director, assisted by the two sub-directors. The punishments range from simple fines to confinement in cells and expulsion, and the offences for which these may be imposed are insubordination, disorderly conduct, drunkenness, absence without leave, immorality, extravagance, and laziness. In general, however, the conduct of the colonists is excellent.

The estates comprise about 5,000 acres of sandy and gravelly soil, formerly covered with peat, which has long since been removed; and what was formerly beneath it is now left as the surface soil mixed with vegetable matter. Of the total area, 1,250 acres are taken up by six large farms managed by the Society itself with the work of the labourers; 1,500 consist of woods, and more than 1,500 are cultivated by the free farmers and the labourers, the remainder consisting of roads, canals, heath, and open spaces.

The cultivation of the land is of course adapted to the nature of the sandy soil, but the processes are all primitive, as the object is to find employment for a large number of people rather than to economise labour by the use of machinery. The ordinary course of cropping is (1) rye, (2) oats, (3) buckwheat, (4) potatoes, but not always in this sequence. After the rye is harvested, stubble turnips and spurrey are taken on portions of the land the same year, and ordinarily a part of the potato course is sown with white turnips, and more extensively with kohlrabi. Only about one-tenth of the corn-breaks is sown with clover and rye grass, as clover only succeeds well when sown once in every eight or ten years. On the highest land broom is sometimes sown in the rye and allowed to grow the next year, thus displacing a crop of oats; in the autumn it is ploughed in green as manure, and is followed the next year by potatoes. Of late years greater attention than before has been paid to the cultivation of root crops, such as turnips, kohlrabi,



rabi, and carrots; and to fodder plants, such as vetches, clover, and maize. The green fodder is ensiled either beneath the ground, or in stacks by Blunt's apparatus. Potatoes are kept in large low barns, partly dug out of the sandy soil, and roofed with thick layers of turf.

In the year 1890, 163 acres of the Society's six farms were planted with rye, 61 with oats, 44 with buckwheat, 192 with potatoes,<sup>1</sup> 37 with grass and clover, 17 with mangel, 5 with beans, 14 with roots, 17 with fodder plants, 20 with peas, and 7 with various, while 331 acres were in permanent pasture. About 20 acres on the estate are devoted to market gardening. Vegetables, such as peas, beans, haricots, carrots, etc., and fruits, such as apples, pears, plums, apricots, etc., are dried at a private drying establishment on the estate (established in 1888), and are sent all over Holland, where they are much esteemed. About 56% is spent annually on each of the six farms for artificial manures, consisting of basic slag, kainit, and nitrate of soda.

A feature of the cultivation that has received much attention, especially since the establishment of the forestry school, is the care of the woodlands. The greater part of these are planted with firs, and the remainder with oaks. The land is dug a yard deep by the spade, and acorns are sown in rows. After two or three years the young plants are transplanted, and again after a similar interval of time at wider distances. Here they remain until they are about ten years old, when they are felled, the bark being sold for tanning and the wood for fuel.

All the cattle on the farms are bred on the estate; but bulls for stud purposes are bought annually in Friesland. Milking qualities are especially studied in the rearing of cows, and only those are bred from which have been proved to give plentiful and good milk. In the Annual Report for 1890 particulars are given of the yields of milk of the 150 cows on the farms, from which it appears that two gave over 1,000 gallons of milk in the year, one over 900 gallons, five over 800 gallons, 11 over 700 gallons, 23 over 600 gallons, 27 over 500 gallons, 26 over 400 gallons, and 12 over 350 gallons, the remaining 43 being under this standard. The average yield is 575 gallons, and the milk is stated to contain from two to four per cent. of butter-

<sup>1</sup> In view of the interest which has recently been excited on the subject of the preventive treatment of potatoes against disease, it may be worth mentioning that last season a portion of the potatoes on the estate was dressed with *deuillie bordelaise*, the first time at the end of June, and the second in the middle of July. The result was that on the 50 acres so treated there was an increase in the yield of from 36 to 72 bushels per acre. The cost of the two dressings was about 10s. per acre.

fat. All the milk produced is made into butter and cheese at a central dairy founded in 1882, which is excellently fitted up and managed.<sup>1</sup> The cheese, butter, and milk sold yielded 910*l.* during the year.

The cattle pass the summer in the pastures, but are fed also with grass, clover, maize, etc. In the winter they are kept in the cowhouses, where they receive hay, carrots, peas, roots, oats, silage, and oilcake. The cost of feeding each cow during the winter varies from 7*l.* to 8*l.* The greater number of cows calve in spring; but care is always taken to have some of the cows in milk during the winter.

On the day of our visit there was a special parade of the live-stock of the farm, and very fine specimens of the omnipresent Dutch breed the working oxen and milch cows were. A giant subsoil plough with six oxen harnessed to it, and a Frisian milch sheep with an udder almost as big as a cow's, were features which specially attracted our attention.

It is a little difficult to gather from the accounts a precise statement of the financial operations of the Society; but it is undeniable that the farming *per se* does not pay, and that it is only the annual subscriptions of the subscribers, and donations, that keep the colony afloat. Considering the circumstances under which the colony was originally located on a barren tract of land, and the nature of its work, it cannot, however, be looked at purely from a financial point of view, but must be regarded as a philanthropic institution wasting infinitely less money than some others nearer home that could be mentioned.

The criticism on the Society's system which at once arises to the mind is, that its benefits are restricted to so few people. I had the advantage of travelling between Steenwijk and Frederiksoord in a carriage with Monsieur Méline, a former Minister of Agriculture in France, and the President of the Hague Congress, Monsieur Tisserand, the well-known chief of the French Agricultural Department, and Dr. Löhnis; and we urged this point somewhat strongly upon the Director. Dr. Löhnis agreed that the small number of fresh families admitted to the advantages of the colony was a drawback; but he pointed out that so long as the Society took upon itself the care of the families whilst they were on its property it was impossible to turn them out. When a family was accepted, the husband as well as the wife were entitled to remain during their lives in

<sup>1</sup> The system of feeding calves described in Mr. Jenkins' Report of 1882 to the Duke of Richmond's Commission is no longer in vogue. All the milk of the six farms is brought to the central dairy to be turned into butter and cheese.

the undisturbed occupation of the cottage allotted to them, provided their conduct was good. He did not seem to be averse to emigration, but thought the Society would render a very questionable benefit to its *protégés* if it compelled them to leave the colony after a few years to make room for others. He insisted very strongly upon the beneficent work of the Society in educating the children of the colonists. He regarded the highest and noblest duty of the Society to be the training of the children to become useful citizens, and pointed to the large number of well-arranged schools that had been instituted to teach them trades and handicrafts. When the children were started in life, the Society continued to look after the parents if they were still living, and supported them entirely if they were too old or infirm to work. This system was, he admitted, very expensive, and restricted greatly the number of families that could be relieved; but he did not see how, under the general principles of the Society's work, it could be improved upon, nor how the Society could now change its system.

The subject is one which it is perhaps beyond the scope of this Journal to discuss at any greater length; but it certainly appears to an outside observer that the admission of only about six new families a year, in face of an annual deficit on the working of over 1,000*l.*,<sup>1</sup> merits the careful attention of those responsible for the management of the institution.

For everything else concerning the Colony no one can have anything but praise. The district committees are proud of it, and interested in its work. Its devoted Director spares no pains, thought, or time to ensure its success. The colonists look happy, contented, and prosperous, and the land (once a desert) is now smiling with comparative plenty.

### THE BEGGAR COLONIES.

The Beggar Colonies at Veenhuizen, near Assen, capital of the Province of Drenthe, and at Ommerschans, in Overijssel, are maintained by the Government as reformatories for vagrants, drunkards, and other delinquents who are not actually criminals. The estates comprise 12,500 acres, and, as stated above, formerly belonged to the *Maatschappij van Weldadigheid*, by whom they were sold to the Government. There are four "colonies," namely, three for men and one for women, and there are about 2,000 male and between 400 and 500 female colonists. About 2,500

<sup>1</sup> It is only fair to say that 600*l.* of this deficit is represented by interest on a loan contracted with a Mortgage Bank, which will be repaid in about twenty years.

acres of the estates are in arable culture, and there are 11 farmsteadings belonging to the "colonies," besides a large number of farms which are at present let to tenants. The course of agriculture is designed to supply the wants of the "colonies," nearly all the produce being consumed on them. The course of cropping pursued is: (1) rye followed by spurrey or stubble turnips, (2) potatoes or oats, sometimes a little mangel or kohlrabi in place of potatoes. The root course is not always taken, and forms a third year when it follows rye and precedes oats, with which clover and seeds are sown, and remain down three or four years.

The colonists are made to work at different trades, having some relation to their previous occupation, some being agricultural labourers, others bakers, tailors, blacksmiths, carpenters, weavers, sack-makers, esparto-grass mat-makers, and almost every other kind of industry that can be carried on without the aid of steam power. Most of the products are used in the colony. Thus the cloth woven (a rough kind of frieze of a khakee colour) is used to make dresses for the men and women in the tailoring department, but the esparto-grass mats are always sold. The women are chiefly occupied as laundresses and seamstresses. There are canteens where the colonists can buy certain luxuries with the proportion of their earnings which they receive (a certain proportion being kept back until their term is expired); these include various articles of food, and also tobacco, but no intoxicating liquors. The reclamation of waste land is the chief means adopted by the Government of the Netherlands for the utilisation of the labour of vagrants and vagabonds at these colonies, as also it is of other classes, both within and without the pale of the law, at other institutions on the same lines.

ERNEST CLARKE.

---

# Official Reports.

## REPORT OF THE COUNCIL

TO THE

HALF-YEARLY GENERAL MEETING OF GOVERNORS AND MEMBERS,

HELD IN THE

HALL OF THE ROYAL MEDICAL AND CHIRURGICAL SOCIETY,

*At 20 Hanover Square, W.,*

ON THURSDAY, DECEMBER 10, 1891,

The EARL of FEVERSHAM (President) in the Chair.

---

THE Council have to report that the List of Governors and Members has undergone the following changes during the half-year which has elapsed since the Anniversary General Meeting on May 22 last:— 5 new Governors and 351 Members have joined the Society, 3 have been elected Honorary Members, 3 have been re-instated as Members under Bye-Law 12, and 8 Members have qualified as Governors; whilst the deaths of 11 Life Governors, 1 Annual Governor, 36 Life-Members, and 98 Annual Members have been reported. A total of 3 Members have been struck off the books under Bye-Law 10, owing to absence of addresses; 58 under Bye-Law 11, for arrears of subscriptions; and 107 have resigned.

2. The Council regret to announce the death of five more of the Foundation Members of the Society, elected before the Charter was granted in 1840, viz.: Mr. Frederick Calvert, Q.C., of 38 Upper Grosvenor Street, W.; Mr. R. Dawtrey Drewitt, of Arundel; Mr. John Glover, of Tamworth; Mr. Frederick Neame, of Luton, Selling, Faversham; and Mr. Henry Smith, of Leamington. Amongst other Governors and Members whose loss by death the Society has had to deplore during the past half-year are the Duke of Cleveland, the Earls of Clonmell, Dartmouth, Portsmouth, Westmorland, and Wicklow, Viscount Combermere, Lord Methuen, the Right Hon. W. H. Smith, M.P., the Hon. Payan Dawnay, Sir C. E. Dods-worth, Bart., Sir Robert Fowler, Bart., M.P., Sir Prescott Hewitt, Bart., Sir John Neeld, Bart., Sir J. H. Preston, Bart., Sir

P. d'E. Skipworth, Bart., Sir R. R. Wilmot, Bart., Sir John Hawkshaw, F.R.S., Mr. Samuel Bate of Leicester (a Member since 1843), Mr. G. H. Bond, M.P., Mr. Thomas Bowstead of Penrith, Mr. John Clayton of Newcastle-on-Tyne (a Member since 1846), Mr. E. L. Gatacre of Bridgnorth and Mr. Thomas Kesterton of Sutton (Members since 1841), Mr. Lewis Loyd, Mr. Charles Magniac, Mr. James Martin of Wainfleet, Mr. J. P. Stocker (who has generously bequeathed 100*l.* to the Society), Mr. W. Trethewy of Tregoose, Cornwall, Lieut.-Col. T. Picton Turbervill (a Member of the Council from 1874 to 1884), and Mr. James Williams of Abingdon (a Member since 1842).

3. The Council have elected the following gentlemen as Honorary Members of the Society, in recognition of their distinguished services to European Agriculture :—

Professor Hermann HELLRIEGEL, Director of the Versuchs-Station, Bernburg, Anhalt, Germany.

Monsieur LOUIS PASSY, Perpetual Secretary of the Société Nationale d'Agriculture de France, Paris.

Dr. C. J. SICKESZ VAN DER CLOESE, President of the Royal Agricultural Commission of Holland, The Hague.

4. These and other changes bring the total number of Governors and Members now on the Register to 10,973, divided as follows :

29 Foundation Life Governors (Members elected before the granting of the Charter on March 26, 1840) ;

66 Governors paying an annual subscription of 5*l.* ;

83 Life Governors who have compounded for their annual subscriptions ;

22 Honorary Members ;

6,966 Members paying an annual subscription of 1*l.* ;

16 Members who, having paid annual subscriptions for 50 Years, have become Life Members ;

3,719 Life Members who have compounded for their annual subscriptions ;

72 Life Members by Examination ;

---

10,973 Total number of Governors and Members ;

or a net increase of 45 Members during the half-year.

5. The Council think it desirable, however, again to urge upon the Members that the maintenance of the Society's operations on their present scale depends upon a continued flow of new subscribers. At least 500 new Members need to be elected every year to take the place of those who die or retire. Each Member is therefore particularly invited to interest himself in obtaining new subscribers to the Society, and to suggest the names of any farmers or others interested in agriculture, in his district or of his acquaintance, who would be likely to become Members. The Secretary will, upon receipt of instructions, either write direct to the gentlemen named,

or will forward a supply of application forms to the nominating Member. A form of nomination is printed in each number of the Journal.

6. The vacancy caused by the death of the late Earl of Powis has been filled by the transference of Sir John Lawes, Bart. (Vice-President), to the list of Trustees. Mr. H. Chandos-Pole-Gell has been elected to the Vice-Presidency thus vacated, and Mr. J. Marshall Dugdale of Llwyn, Llanfyllin, Montgomeryshire, to a seat upon the Council.

7. The entries of live stock at the Society's Country Meeting held at Doncaster last June were larger by nearly 400 than at any previous ordinary Meeting of the Society, despite the new rule limiting to three the entries in the same class that could be made by any Exhibitor; and the number of Implements shown was also above the average. The Show week was favoured (with the exception of one afternoon) with fine weather, and everything possible was done by the local authorities, the railway companies, and others concerned, to make the Show a success. The Meeting fully answered its primary object by bringing together a fine representative collection of live stock of the different breeds, and in introducing to the notice of the public the latest developments in farm machinery and appliances.

8. The large number of entries of live stock, especially of horses, involved the Society, however, in an unusually heavy expenditure for stables and buildings, which was not recouped by the entry fees; and, in consequence of the enormous quantity of timber to be disposed of at the sales held after the Meeting, only moderate prices were realised. The magnitude of the Show had also its effect in increasing the cost of administration of various other departments; and as the Prizes were about 500*l.* more than at Plymouth, the total expenditure exceeded that of last year by about 2,800*l.* On the other hand, the receipts were 5,000*l.* more than at Plymouth, the chief items of this increase being 1,100*l.* for implement entries, 500*l.* for stock entries, and 2,750*l.* for receipts for admission.

9. As a final result, the accounts of the Meeting, as passed by the auditors on November 16 last, show a profit of 103*l.* 17*s.* 8*d.*, as against a deficit of 2,197*l.* at the Plymouth Meeting. This result, as the balance is on the right side, can hardly be described as unsatisfactory; but, considering the special efforts that were made, particularly by the railway companies, to attract visitors to the Show, it is in some measure disappointing.

10. The Council have decided that the Warwick Meeting shall open on Monday, June 20, 1892, and close on the following Friday evening. The Implement Yard and the Dairy will be open to Members of the Society and the public on the previous Saturday, June 18. The last day for making entries in the Implement De-

partment will be Friday, April 1 ; but post-entries, of agricultural implements only, will be received up to Friday, April 8. For Stock, Poultry, and Produce, the entries will close on Saturday, April 30, with post-entries at double fees up to Thursday, May 12.

11. The Council have already reported their decision to offer in connection with the Warwick Meeting prizes amounting in all to 120*l.* for different descriptions of ploughs. Seventy-two entries from eleven firms have been received for the competition, which will be held in the neighbourhood of Warwick in the spring of next year.

12. The prize-sheet for Stock, Poultry, and Produce has now been definitely settled, and will be issued immediately. The prizes given by the Local Committee include five classes for Hunter Mares or Geldings, two classes each for Hackney, Pony, and Harness Mares or Geldings, two for Agricultural Geldings, two for Longhorn Cattle, two for Shropshire Sheep, five for Goats, and one for Butter. The Local Committee will also give Champion Prizes for Hereford Cattle, and Oxford Down and Shropshire Rams.

13. The classes for Horses offered by the Society itself will include Hunters, Coach Horses, Hackneys, Ponies, Shires, Clydesdales and Suffolks. The Council have decided that the regulation requiring that no stallion shall be awarded a prize until a veterinary examination has pronounced him free from hereditary disease shall for the future be extended to brood mares.

14. In the Cattle Classes, prizes will be offered by the Society for the Shorthorn, Hereford, Devon, Sussex, Welsh, Red Polled, Jersey, Guernsey, Kerry and Dexter Kerry breeds, as well as for Dairy Cattle giving the greatest quantity of milk containing not less than twelve per cent. solids, and three per cent. butter-fat. A separate class has been added for Dairy Cows which shall have calved not less than three months before the date of the Show.

15. The Classes for Sheep will include Leicesters, Cotswolds, Lincolns, Oxford Downs, Shropshires, Southdowns, Hampshire Downs, Suffolks, and Border Leicesters, with the local breeds of Clun Forest and Welsh Mountain ; and those for Pigs will include the Large White, Middle White, Small White, Berkshire, Black, and Tamworth breeds. The Council have resolved to extend to Pigs the regulations that all animals entered must be eligible for entry in the Herdbooks of their respective breeds, and that no animals which have been exhibited as Fat Stock at any Show shall be eligible to compete for the Society's prizes.

16. Prizes will also be given for useful descriptions of Poultry, including Table Fowls and Ducks ; for Cheese of 1892 make, and Soft Cheese ; for Fresh and Salt Butter ; for Cider and Perry ; and for Jams and Preserved Fruits made in 1891. The British Bee-



keepers' Association will continue their Prizes for Hives, Honey, and Bee Appliances.

17. Butter-making Competitions will be continued at Warwick in four classes, five Prizes being offered in each class. There will also be a competition of Shoeing Smiths practising in the counties comprised in the district of the Show. The competition will be in two classes, viz. for Roadsters and Dray Horses, and five Prizes will be offered in each class. The Worshipful Company of Farriers have generously offered, as before, to provide the First Prize in each of these two classes, and to bestow the Freedom of their Guild upon the two first-prize winners. The Registration Committee of the Worshipful Company will also admit all the winners of prizes in these Competitions to the official register of Farriers or Shoeing Smiths free of charge.

18. Seven Prizes amounting to 300*l.* have been offered in three classes by the Warwick Local Committee for the best-managed Farms in the county of Warwick. The number of farms entered for competition is twenty-six, and the Judges will start on their first tour of inspection early in January.

19. At the request of the Royal Commission on Horse Breeding, the Council have agreed to continue for another year the grant of three premiums of 200*l.* each for Thoroughbred Stallions serving Mares in the Society's District F, in which the Country Meeting of 1892 is to be held. The Warwick Local Committee have promised to bestow a Gold Medal upon the owners of each of the three Stallions winning the Society's Premiums, which will be competed for at the same time, and under the same conditions, as the twenty-two Queen's Premiums offered by the Royal Commission on Horse-breeding.

20. Memorials have been received from the Corporations of Chester and Manchester inviting the Society to hold its Country Meeting of 1893 in their respective cities. The customary Committee of Inspection has been appointed to report on the sites and other accommodation offered by each locality, and a final decision as to the place of the Country Meeting of 1893 will be made by the Council in February next.

21. As the Meeting of 1893 will be held in a district specially interested in dairying, it is proposed to offer in connection with that Meeting prizes for Cheese made in 1892 in addition to prizes for Cheese made in 1893, as well as increased prizes for dairy produce generally.

22. The scheme for the National Registration of Farriers or Shoeing Smiths, in which the Society is associated with the Worshipful Company of Farriers and the Royal College of Veterinary Surgeons, is now in full working order; and it is gratifying to find that already 3,340 shoeing smiths have been placed upon the official

register of the Farriers' Company. A vacancy on the Committee caused by the resignation by Mr. Walter Gilbey has been filled by the election of Col. Sir Nigel Kingscote, K.C.B.

23. The Council have appointed Mr. D. M. Storrar, F.R.C.V.S., of Abergavenny, as the Society's Provincial Veterinary Surgeon for Monmouthshire, in succession to Mr. G. Lewis, of Monmouth, resigned.

24. It is satisfactory to find that the strenuous and sustained efforts of the Board of Agriculture to stamp out pleuro-pneumonia in this country appear to be now meeting with considerable success. The number of outbreaks, which in the preceding year reached 499, fell to 295 in 1891. In the outbreaks which occurred in the course of the current year, 1,188 cattle were slaughtered while affected with pleuro-pneumonia. But in addition to these, the plan adopted by the Board of slaughtering all cattle which had been in contact with the disease or had been in any manner exposed to the risk of infection necessitated the slaughter of a total of 14,322 cattle, including those (1,188) which were affected.

25. Swine-fever began to increase rather rapidly about the end of March, the maximum being reached soon after the middle of May, since which the disease has decreased. At their meeting held on June 3 last, the Council passed a resolution requesting the earnest attention of the Board of Agriculture to the urgent necessity of adopting more stringent measures to mitigate the severity of this disease.

26. There has been a slight increase in the number of outbreaks of anthrax this year as compared with last; but it is satisfactory to note that the area over which the disease is distributed has not been extended. Husk or hoose (lungworm) has been rather prevalent in some districts; but the anticipated extensive outbreak of liver-rot (flake) in sheep has not taken place.

27. Some important investigations have been carried on in the Department of Comparative Pathology at the Royal Veterinary College during the year, especially in reference to contagious foot-rot among sheep. Further experiments have been made to test the infectivity of meat from tuberculous animals after various degrees of cooking. Inquiries into the origin and treatment of husk in calves and lambs have been continued, and recently special investigations have been carried on in reference to abortion in cows in different parts of the country. A paper on this subject by Professor Brown will appear in the forthcoming number of the Journal.

28. At the request of the authorities of the Institutions concerned, the Council have nominated the President of the Society for the time being to act *ex officio* as the Society's representative upon the permanent governing body of the Imperial Institute, and upon the Council of the British Institute of Preventive Medicine.

**29.** During the last six months 640 samples have been sent by members to the Society's laboratory for analysis, showing a falling off to the extent of about 60 samples as compared with last year. This is probably accounted for by the lateness of the harvest season. The number of linseed-cakes especially has been considerably reduced, but many more instances are now met with of purchases being made in accordance with the Society's recommendation to purchase these under the guarantee of "pure linseed-cake." It is satisfactory to record that where this has been done, the articles supplied have, in the majority of cases, been found good. Speaking generally, it may be said that the quality of "linseed-cake" has improved, while that of the nondescript article known as "oil-cake" has gone from bad to worse.

**30.** At the Woburn experimental farm the most important of the Feeding Experiments was one upon the relative Feeding-value of Decorticated and Undecorticated Cotton-cake. The results of two different years' experiments are recorded in Part III. of the Society's Journal for the current year. The other field experiments are in progress as before. Fresh feeding experiments for the winter of 1891-92 have recently been commenced. Of Local Agricultural Societies, the Norfolk Chamber of Agriculture, the Essex Agricultural Society, and the Lancashire Agricultural Society have continued their experiments in conjunction with this Society.

**31.** The experiments undertaken at the request of the Board of Agriculture for the purpose of determining the efficacy of sulphate of copper as a remedy against the potato disease have now been satisfactorily carried out in six different districts during the past season, and a detailed statement of the results will appear in the forthcoming number of the Journal. The experiments of a single year do not supply data on which generalisations of any permanent value can be based, but the experiments show that the "Bouillie Bordelaise" has not prevented the disease in any of the localities, though it has decreased the amount of disease in the plots to which it has been applied, and has decidedly increased the yield of tubers.

**32.** The grass seeds examined by the Consulting Botanist during the year have been, with very few exceptions, satisfactory, but a large proportion of the clovers have contained the seeds of weeds, and dodder has been present in an unusual number of the samples of alsike. Some investigations have been made into the cause of abortion, which seem to indicate that ergot is not the principal cause of this malady. Several diseases injuring cultivated crops have been investigated, and suggestions made for their prevention.

**33.** The work of the Honorary Consulting Entomologist's Department continues steadily to increase. Miss Ormerod reports that during the past season almost all the commonly known infestations have been more or less present, and that the experience of the year has in no way justified the hope expressed by some

early in the season, that "the cold would have killed the grubs." The most serious and widespread attack has been that of the Diamond-back Moth, a full report on which was published in the September number of the Journal. Mangel Fly was more prevalent (especially in Devonshire) than in any years since its first great appearance in 1880. The destructive infestation of the Wheat Bulb Maggot was again seriously mischievous, mainly in the Eastern Counties; and Miss Ormerod, in her annual report for 1891, shows cause for thinking that the attack arises by maggots from eggs laid in the land during the summer. Considerable attention has been devoted to the strig maggot in hops and to the apple saw fly, and great advance has been made in knowledge of practically useful insecticides, especially of Paris green, and in introduction of spraying machines for their application.

34. As a result of the Examination for the Society's Senior Prizes and Certificates, which took place on May 12 to 16 last, nine of the thirteen candidates satisfied the examiners; and the following competitors, placed in order of merit, gained First-class Certificates, and thus became Life Members of the Society; the first four being entitled, in addition, to the prizes stated below:—

1. RAOJI BHAILAL PATEL, Royal Agricultural College, Cirencester. *First Prize of 25l.*
2. EDRIC DRUCE, Royal Agricultural College, Cirencester. *Second Prize of 15l.*
3. JAMES GUNTER, Estate Office, Glasbury, Radnorshire. *Third Prize of 10l.*
4. JOSEPH LISTER, Agricultural College, Aspatria. *Fourth Prize of 5l.*
5. HENRY FREDERICK HILL, Agricultural College, Aspatria.
6. PERCY CHARLES BURTON, The Elms, Pontyclown, Glamorgan.
7. ERNEST ALLEN STAPLEDON, Royal Agricultural College, Cirencester.
8. HARRY AUSTIN LINDSAY YOUNG, Loseley House, West Horsley, Leatherhead.

The following candidate, having passed in Agriculture and in three of the four other compulsory subjects, was awarded a Second-class Certificate:—

9. ROBERT JAMES IRVING, Blackhall House, Carlisle.

35. The Annual Examination for the Society's ten Junior Scholarships of 20l. each took place on November 10 and 11, when forty-five candidates competed. Of these eighteen passed in all four subjects (Agriculture, Chemistry, Mechanics, and Land Surveying), and obtained the number of marks necessary to qualify them for the Society's Scholarships and Certificates, in the event of their complying, during the forthcoming year, with the conditions of the Examination. Two other boys passed in each of the four subjects, but, not having obtained the minimum aggre-

gate of marks, are ineligible for Certificates. Of the twenty-five other unsuccessful candidates, thirteen failed in one subject, seven in two subjects, four in three subjects, and one in all four subjects. There were five failures in Agriculture, thirteen in Chemistry, seventeen in Mechanics, and eight in Land Surveying. Of the eighteen successful candidates, the first ten in the following list will receive Scholarships upon complying with the Society's regulations, and the remainder will receive Certificates :—

1. JOHN ROBERT WOOD, Aspatria Agricultural College.
2. JAMES MCCREATH, Maybole Public School, N.B.
3. JOSEPH HARKER NEWMAN, Surrey County School.
4. WILLIAM ARTHUR WESTLEY, Northampton Grammar School.
5. GEORGE WILFRID ARMSTRONG, Aspatria Agricultural College.
6. ERNEST EDGEcombe, Ashburton Grammar School.
7. ERNEST CLAYTON, Aspatria Agricultural College.
8. GWYN REID THOMAS, Aspatria Agricultural College.
9. JOSEPH T. DE LA MOTHE, Aspatria Agricultural College.
10. JOHN PUDDICOMBE, Aspatria Agricultural College.
11. NORMAN ENDACOTT, Ashburton Grammar School.
12. WILLIAM MADDICOTT, Aspatria Agricultural College.
13. GEORGE DYKES PORTEOUS, Maybole Public School, N.B.
14. HENRY JOHNSON, Swanley Horticultural College.
15. JOHN HENLEY, Dunn Foundation School, Crediton.
16. CHARLES HENRY TAYLOR, Surrey County School.
17. FRANK JACKSON BADCOCK, Ashburton Grammar School.
18. WILFRID GILBERT BOWER, Surrey County School.

**36.** In the report to the last General Meeting, mention was made of the intended preparation of a Text-Book which had been undertaken by the Society, in compliance with the many demands that had been addressed to it for an elementary work on agriculture adapted for use in rural and other schools and classes. The general scheme of the work was settled by a Sub-Committee appointed by the Council, and consisting of Lord Moreton (Chairman), Major Craigie, Mr. C. De L. Faunce De Laune, Mr. D. Pidgeon, Mr. Martin J. Sutton, and Mr. Charles Whitehead. The detailed preparation of the Text-Book was placed in the capable hands of Dr. W. Fream, and the proof-sheets have been submitted to and revised by distinguished authorities in each branch of the subject. The book has now been completed, and will be published on the 1st January next, under the authority of the Society, by Mr. John Murray. It will consist of 450 pages, with 200 illustrations, and it is hoped that it will be found fitted to become a standard work on the subject of which it treats. With the object of making it as generally useful and available as possible, the Council have fixed the publishing price at half a crown, which, spreading the expense of production over a large number of copies, is as nearly as possible the cost price.

By Order of the Council,

ERNEST CLARKE,  
*Secretary.*

QUARTERLY REPORT OF THE CHEMICAL  
COMMITTEE,

DECEMBER, 1891.

1. Mr. R. H. Newill sent on October 15, on behalf of the Earl of Powis, Walcot, Lydbury North, Shropshire, a sample of linseed-cake, two-and-a-half tons of which had been purchased from Messrs. Marston Bros., Bull Ring, Ludlow, agents for the manufacturers, Messrs. Earles and King, Liverpool. The cake was invoiced as "E. & K. Linseed cake," and each piece was branded with the name of the makers; the price was 9*l.* 10*s.* per ton delivered.

The following analysis and report was returned:—

		October 22, 1891.
Moisture . . . . .		14.45
Oil . . . . .		9.60
<sup>1</sup> Albuminous compounds (flesh-forming matters) . . . . .		26.56
Mucilage, sugar, and digestible fibre . . . . .		29.13
Woody fibre (cellulose) . . . . .		9.10
<sup>2</sup> Mineral matter (ash) . . . . .		11.10
		100.00
	<sup>1</sup> Containing nitrogen . . . . .	4.25
	<sup>2</sup> Including sand . . . . .	5.85

This cake is impure, containing, as it does, nearly 6 per cent. of sand. The price, 9*l.* 10*s.* per ton for a cake containing only 9½ per cent. of oil—even supposing it to have been a pure one (which this is not)—is very high.

On complaining to Messrs. Marston Bros., the latter forwarded a copy of a reply which they had received from Messrs. Earles and King, and which ran as follows:—

A 17 and 18 Exchange Buildings, Liverpool: October 31, 1891.

DEAR SIRS,—We are very sorry to hear of any complaint of our cake. The seed this season has been very poor, and it is impossible to screen it as we should like. We beg to point out that we give no guarantee as to oil in our cake—to anyone who will *pay for it* we will give as much as they want; but we at once admit 6 per cent. sand is too much, and we will make your friend 10*s.* a ton allowance on the two tons. This pays him for the *whole of the sand*, and we will send you the money on hearing that our proposal is satisfactory. Please let us have a sample of the cake.

Yours faithfully,  
EARLES & KING.

Messrs. Marston Brothers, Ludlow.

Mr. Newill accepted the allowance of 10*s.* a ton offered.

2. The following case illustrates well the difficulties which may arise when linseed-cake, guaranteed as "pure," is made, not by the vendors themselves, but *for* them under a contract

with the crushers. It shows how, with the best intentions on the part of the vendors, mistakes may arise unless they take the necessary steps to secure themselves against what is sent out on their responsibility being below the guarantee they give:—

A member of the Society forwarded on October 27 a sample of linseed-cake, four tons of which he had purchased at 9*l.* 6*s.* 3*d.* per ton for cash, delivered, and which was described to him as “95 pure linseed-cake.”

The vendors, though not themselves the manufacturers, had had the cake specially made for them under a contract from the makers in the same terms as those upon which they sold the cake.

When forwarding the sample to Dr. Voelcker for analysis, the member also sent a piece to the vendors. They wrote in reply on October 27: “We are a little disappointed in the appearance of the samples, though we quite hope the analysis will come out up to our standard.”

The following analysis and report was given:—

October 31, 1891.		
Moisture . . . . .	15·10	} 100·00
Oil . . . . .	11·03	
<sup>1</sup> Albuminous compounds (flesh-forming matters) . . . . .	32·13	
Mucilage, sugar, and digestible fibre . . . . .	28·08	
Woody fibre (cellulose) . . . . .	7·26	
<sup>2</sup> Mineral matter (ash) . . . . .	6·40	
<sup>1</sup> Containing nitrogen . . . . .	5·14	
<sup>2</sup> Including sand . . . . .	1·15	

The cake is an impure one, containing a considerable quantity of rape and other foreign seeds.

From the correspondence which ensued, it appeared that the vendors employed contractors to make and brand cake for them, and that, in order to save carriage, the cake was frequently sent direct from the mills to customers without being seen by the actual vendors. A winter contract was being carried out in this way, the makers guaranteeing the purity and quality of the cake to the vendors. The delivery sent to the purchaser was, however, made from seed which had not been tested before the manufacture had commenced, and which was subsequently found to contain more impurity—chiefly oleaginous seeds other than linseed—than it should have had. Thereupon the crushers, according to their account, stopped making the cake for the vendors from this seed, but the four tons had been meantime despatched, and nothing more was said about it until the purchaser complained. The crushers, on receiving the sample, admitted that they could tell from the appearance of the cake that it was made from the identical lot of inferior seed. The vendors, on their part, accepted the entire responsibility so far as the purchaser was concerned, and duly made an allowance to him, expressing their regret, and explaining that they had not been informed, as they ought to have been, of the despatch of the

cake made from the inferior seed. The purchaser, while accepting the allowance, pointed out the unsatisfactory nature of the reply of the crushers, and the uselessness of guarantees between contractors and sub-contractors, when neither party took any steps to ascertain whether the conditions of the guarantee were being fulfilled, or to see whether the cake sold to customers was really "pure" cake as stated to be.

3. Mr. E. L. Peel, on behalf of Lord Hastings, Melton Constable, East Dereham, Norfolk, forwarded on November 2 a sample of linseed-cake, which, after analysis, was reported upon as follows :—

November 6, 1891.		
Moisture . . . . .	11.55	} 100.00
Oil . . . . .	9.66	
<sup>1</sup> Albuminous compounds (flesh-forming matters) . . . . .	28.31	
Mucilage, sugar, and digestible fibre . . . . .	36.62	
Woody fibre (cellulose) . . . . .	8.46	
Mineral matter (ash) . . . . .	5.40	
<sup>1</sup> Containing nitrogen . . . . .	4.53	

This is not a pure cake, but contains considerable admixture of weed seeds and starchy impurities.

The price of the cake was 9*l.* 5*s.* per ton on rail. The present transaction consisted of one ton only, but large quantities had been purchased from the firm before. Mr. Peel added that he believed the vendors were not the makers of the cake, but only acted as agents, and, being dissatisfied with the quality of it, he was anxious to have Dr. Voelcker's opinion on it.

The order was given for "1 ton linseed-cake," but the description on the invoice was "1 ton S Riga cakes."

This case illustrates how necessary it is that purchasers should see that the invoices correspond with the orders they give.

4. In reference to a case reported in the last Quarterly Report (July 1891) of the Chemical Committee, and published on page 633 of the *Journal* for September 30, 1891, Messrs. R. and J. Hewetson, of 1 Catherine Court, E.C., have requested that a fuller explanation of the case be given in a succeeding issue.

The Committee accordingly give in full the further correspondence that has passed.

The case as previously reported read as follows :—

"Mr. G. W. Finn, of Westwood Court, Faversham, sent on June 4, 1891, a sample of American linseed-cake for analysis, he having purchased about thirty tons of this cake from Messrs. Wakeley, Rainham, Kent. It was known as 'Dean's' Cake, the price being 8*l.* 10*s.* per ton. The report given on this sample was as follows :—



	June 9.
"Moisture . . . . .	10.25
Oil . . . . .	9.10
<sup>1</sup> Albuminous compounds (flesh-forming matters) . . . . .	27.75
Mucilage, sugar, and digestible fibre . . . . .	31.54
Woody fibre (cellulose) . . . . .	10.76
<sup>2</sup> Mineral matter (ash) . . . . .	10.60
<sup>1</sup> Containing nitrogen . . . . .	4.44
<sup>2</sup> Including sand . . . . .	5.05

-100.00

"This is an impure cake, containing over 5 per cent. of sand.

"No allowance was made by the vendors. They sent Mr. Finn the copy of an analysis of what they said was the same cake as supplied to him. This was as follows:—

"COPY OF ANALYSIS OF 'DEAN'S' CAKE.

"Water (lost at 212° Fahr.) . . . . .	9.20
Oil . . . . .	10.60
<sup>1</sup> Albuminous (flesh-forming compounds) . . . . .	29.11
Mucilage, digestible fibre, &c. . . . .	34.30
Indigestible (woody) fibre . . . . .	10.33
<sup>2</sup> Mineral matter (ash) . . . . .	6.46
<sup>1</sup> Containing nitrogen . . . . .	4.60
<sup>2</sup> Containing sand . . . . .	1.10

-100.00

"This is a pure linseed-cake made from very clean seed."

The following letter was received from Messrs. R. & J. Hewetson on October 30, and its receipt acknowledged on the same day:—

1, Catherine Court, London, E.C.; October 29, 1891.

DEAR SIRS,—Referring to our interview with Mr. Clarke on last Tuesday, as to the insertion on page 633 of this quarter's issue of the Journal of the Royal Agricultural Society, we now beg to enclose a copy of letter received from Messrs. Wakeley Brothers.

As agents for the Dean Linseed Oil Co. we think it only fair to them and ourselves that such a report should not go forth without a fuller explanation of the facts of the case: it is clear the original sample was not taken by Mr. Finn, nor have we any evidence to show it was a sample of Dean's cake at all.

At any rate, when fair samples were taken the result was totally different, and so far from the cake being impure, two analysts prove that it was made from the usual 96 per cent. Calcutta linseed, and contained a high percentage of oil.

We regret so long a time has elapsed, but our attention was not drawn to the case until this quarter's edition was sent out.

If any further details are required we shall be glad to furnish them.

Meanwhile we trust you will be so good as to insert the exact circumstances of the case in the next quarterly issue of the Society's Journal.

We remain, your obedient servants,

ROBT. & JNO. HEWETSON.

The Chemical Committee, Royal Agricultural Society.

[Enclosure in Messrs Hewetson's letter.]

Rainham, Kent: October 28, 1891.

GENTLEMEN,—We have enclosed a copy of the three analyses, also the original of Mr. Hughes. We do not appear to have had any written correspondence from or to Mr. Finn; if we had any it is mislaid. The facts are as under.

At Canterbury Market, Mr. Finn told us that he had our cake analysed, and that it proved to be an impure cake, and asked us what allowance we

could make him. We answered him that as we thought cake would drop in price we made him a special quotation, and could not make any further reduction, and told him we had sold this cake for a great number of years, and this was the first complaint we had ever received of the quality. We had often received complaints of the price, but never of the quality, and asked him to show us the analysis, which he first said he was not allowed to do, but subsequently did. We asked him who took the cake he sent to be analysed, and he said his man did. We then asked him if it was taken in his presence, and he said it was not. We then saw you, and you got Mr. Hughes to analyse the same cake, or rather from the same cargo. We then showed this to Mr. Finn, and said as it differed so from his analysis we should suggest that a cake should be taken by us from the parcel we had delivered to him in his presence, and he said he thought it was only fair, and accordingly our Mr. Percy went to his farm and took a piece of cake out of one of the bags with Mr. Finn, and Mr. Finn sent it to Mr. Bernard Dyer, and we think that the facts were not fully and plainly stated in the Agricultural Journal.

Yours respectfully,  
WAKELEY BROS.

Messrs. Hewetson.

*Analysis of Dean's Calcutta Seed Linseed Cake.*

VOELCKER.		HUGHES.		BERNARD DYER.	
Moisture . . . . .	10.25	Moisture . . . . .	9.20	Moisture . . . . .	11.03
Oil . . . . .	9.10	Oil . . . . .	10.60	Oil . . . . .	12.16
<sup>1</sup> Albuminous compounds (flesh-forming matters) . . . . .	27.75	<sup>1</sup> Albuminous compounds (flesh-forming matters) . . . . .	29.11	<sup>1</sup> Albuminous compounds (flesh-forming matters) . . . . .	25.94
Mucilage, sugar, and digestible fibre . . . . .	31.54	Mucilage, sugar, and digestible fibre . . . . .	34.30	Mucilage, sugar, and digestible fibre . . . . .	34.81
Woody fibre . . . . .	10.76	Indigestible fibre . . . . .	10.33	Indigestible fibre . . . . .	7.63
<sup>2</sup> Mineral matter . . . . .	10.60	<sup>2</sup> Mineral matter . . . . .	6.46	<sup>2</sup> Mineral matter . . . . .	8.43
	100.00		100.00		100.00
<sup>1</sup> Containing nitrogen . . . . .	4.44	<sup>1</sup> Containing nitrogen . . . . .	4.60	<sup>1</sup> Containing nitrogen . . . . .	4.15
<sup>2</sup> " sand . . . . .	5.05	<sup>2</sup> " sand . . . . .	1.10	<sup>2</sup> " sand . . . . .	2.96
This is an impure cake, containing over 5 per cent. of sand.		This is a pure linseed cake made from very clean seed.			
June 9, 1891.		June 18, 1891.		July 4, 1891.	

Messrs. Hewetson's letter was laid before the Chemical Committee at its meeting held on November 3, when the Secretary was instructed to reply as follows:—

Royal Agricultural Society of England, 12, Hanover Square, London, W.:  
November 6, 1891.

GENTLEMEN,—I laid before the Chemical Committee, at their meeting held on Tuesday last, your letter of the 20th ultimo, and am instructed to inform you that they are in no way unwilling to publish the correspondence which has been brought to their notice, if you think it desirable that this should be done.

At the same time, the Committee must point out to you that when—as stated in Messrs. Wakeley's letter of October 28—a further sample was drawn by them from the lot delivered to Mr. Finn, it was found on analysis to contain practically 3 per cent. of sand, which, as you are aware, is in excess of what a pure cake should contain.

With reference to your remark, that "it is clear that the original

sample was not taken by Mr. Finn," I am to inform you that a letter received from that gentleman explicitly says that the sample forwarded to Dr. Voelcker was taken out of the middle of a cake by himself.

From the three analyses quoted by you, it appears very probable that the cake varied considerably in quality throughout the bulk; and hence the analyses would differ also. But it is to be noted that each of the two samples drawn by Mr. Finn and Messrs. Wakeley respectively from the delivery sent to Mr. Finn showed an excess of sand which should not exist in a pure linseed-cake.

Yours faithfully,  
ERNEST CLARKE, *Secretary.*

Messrs. R. & J. Hewetson.

The letter from Mr. Finn referred to in the foregoing was as under :—

Westwood Court, Faversham : October 31, 1891.

DEAR SIR,—The linseed-cake which I sent to you was taken out of the middle of a cake by myself, and when Messrs. Wakeley heard I had received a bad report one of the firm called on me and took a piece from another cake exactly in the same manner; I could not say if it was from the same lot as yours, but it would certainly be cake that I had from them as Dean's Calcutta seed cake. It was sent to another analyst, who returned a better report.

Yours faithfully,  
G. W. FINN.

J. Augustus Voelcker, Esq.

I believe Mr. Bernard Dyer had the second piece.

On receipt of the Secretary's letter of November 6, Messrs. Hewetson wrote :—

1, Catherine Court, London, E.C. : November 21, 1891.

GENTLEMEN,—On receipt of your letter of November 6, we wrote to Mr. Wakeley as to his assertion that the first sample was not taken by Mr. Finn, but by his man, and we now have his reply.

The facts are as under :—

"Mr. Finn told me, when he first spoke to me about it, that his man took the cake, and when I wrote to him reminding him of what he said at that time, and that it was contrary to what he since wrote me in answer to my query whether he or his man took the cake, he said he could not swear whether he or his man took the cake, so he asked his yardmen, who said that Mr. Finn took it."

Our complaint is that the account given in the Journal is quite misleading, as the best analysis—that of Bernard Dyer—is left out altogether, and the sample in this case was taken in the presence of Mr. Wakeley and Mr. Finn, and sent by Mr. Finn to Mr. Dyer.

Also the report says: "They sent Mr. Finn the copy of an analysis of what *they said* was the same cake as supplied to him," thereby casting some doubt as to its being the same cake.

We trust the Committee will see that some explanation is due, as it is most unjust to the Dean Linseed Oil Co.'s cake—which is well known to be the finest American cake that is made—that such a report should go forth uncontradicted.

We remain, Gentlemen, yours obediently,  
ROBERT & JNO. HEWETSON.

The Chemical Committee, Royal Agricultural Society.

This letter was laid before the Chemical Committee at its meeting held on December 8, when the Secretary was instructed to reply as follows :—

Royal Agricultural Society of England, 12, Hanover Square, London, W. :  
December 12, 1891.

GENTLEMEN.—The Chemical Committee had under discussion at their meeting on Tuesday last your letter of November 21, and they are quite willing to give publicity in the Society's Journal to the full correspondence, as desired by you.

The Committee would, however, point out that neither the analysis made by Mr. Bernard Dyer nor any letter of explanation was before them at the time the report was published, and this, notwithstanding the fact that the vendors (Messrs. Wakeley Brothers) knew of the complaint made by Mr. Finn about the cake, and had declined to give any allowance for it.

The Committee had no intention whatever of casting any doubt upon the correctness of the copy of analysis given to Mr. Finn. The statement in their report was not a comment of their own, but was taken from a letter by Mr. Finn to Dr. Voelcker, dated June 20, in which that gentleman wrote as follows :—

“The agents from whom I bought have sent me a copy of an analysis which they say is the same cake, and which comes out better than yours, so I have sent you a copy.”

I am, yours faithfully,  
ERNEST CLARKE, *Secretary.*

Messrs. R. & J. Hewetson.

December 8, 1891.

R. A. WARREN, *Chairman.*

---

### SNOWSELL *v.* THE ROYAL AGRICULTURAL SOCIETY.

THE following transcript from the shorthand notes of the proceedings in this case, which was heard before Mr. Justice Wills on October 30, 1891, was laid before the Chemical Committee at their meeting held on November 3, and, on their recommendation, was ordered by the Council to be published in the Journal :—

In the High Court of Justice :  
Queen's Bench Division.

GUILDHALL :  
Friday, 30th October 1891.

Before Mr. JUSTICE WILLS.

SNOWSELL  
*v.*  
THE ROYAL AGRICULTURAL SOCIETY.

---

Mr. COCK, Q.C., and Mr. A. T. LAWRENCE, instructed by Messrs. THORNEYCROFT and WILLIS, Agents for Messrs. TAYNTON SONS and SIVETER, of Gloucester, for the Plaintiff; and Mr. LOCKWOOD, Q.C., and Dr. BLAKE ODGERS, instructed by Messrs. GARRARD JAMES and WOLFE, for the Defendants.

*Transcript from the shorthand notes of Messrs. Hodges and Son, 87 Chancery Lane, W.C.*

Mr. COCK, Q.C.—Will your Lordship allow me to mention the next case?

Mr. JUSTICE WILLS.—Yes.

Mr. COCK.—My Lord, that is an action which has been brought against the Royal Agricultural Society of England by Mr. Snowsell for libel. I do not know whether your Lordship has seen the Record?

Mr. JUSTICE WILLS.—No.

Mr. COCK.—Then, my Lord, I wish to state that I have had an opportunity of consulting with Mr. Lockwood, who represents the Defendants, the Royal Agricultural Society, in this case, and if your Lordship will allow me to make a few statements on behalf of Mr. Snowsell, for whom I appear with regard to that case, I do not think it will be necessary to trouble your Lordship, or the Jury, any further with it. Perhaps it will be a convenient time to do so now, before another witness is called.

Mr. JUSTICE WILLS.—Yes. I think that is reasonable. You do not want the Jury sworn, I suppose?

Mr. COCK.—Oh no, my Lord. We have arranged not to trouble the Jury. This is an action which is brought by Mr. Snowsell, the Plaintiff, who carries on his business as "The Cotswold Association for the supply of pure and unadulterated Artificial Manures and Feeding Stuffs," against the Royal Agricultural Society of England, in respect of certain correspondence which was published in a Report of the Agricultural Society, which Mr. Snowsell considered reflected upon him. It never has been his desire to make money out of this litigation, but he has desired to have an opportunity of stating publicly what his position is with regard to this matter. I have read the papers in this matter, and my friend Mr. Lawrence has read them also, and we entertain no doubt whatever that the course which was taken by the Royal Agricultural Society of England was taken by them with regard to the matters that were before them in accordance with what they considered their duty to the public and to the Members of that Society, and I do not desire to attribute the slightest blame to them, but on the other hand I must say I think they took a course which it was right they should take under the circumstances. But it is desirable that I should now, on behalf of Mr. Snowsell, make one or two statements in regard to the position in which he was placed and the matters which have arisen. Mr. Snowsell, as I have told your Lordship, was a seller of linseed-cake and other food for cattle. He was not a manufacturer, but a person who dealt in it, and he supplied a certain quantity of this linseed-cake which he had purchased to a Mr. Iles. Mr. Iles had that linseed-cake analysed, and he was of opinion that it was not such a cake as ought to have been supplied to him under the description under which it had been supplied, viz., "pure linseed-cake," and he thereupon communicated to the Royal Agricultural Society the result of the analysis which he had had made of this cake, and a further analysis was made by another analyst, and that was also supplied to the Agricultural Society. The Royal Agricultural Society, finding that this cake had been on the market, thought it their duty to publish this analysis and a certain correspondence relating to it; and, as I said just now, I do not blame them for taking that course. But the position Mr. Snowsell occupied in the matter was this: he had purchased this cake from the same firm who had supplied this cake for a great number of years. He had supplied it to his customers in the ordinary course of his business. When he first began to buy it, he had had several analyses made for the purpose of ascertaining what the

quality of the cake was, and those analyses were perfectly satisfactory. He had supplied it, as I told your Lordship, to customers occupying first-rate positions, and to other parties who had had analyses made themselves, and he had had no fresh analysis made, and he thought there was no necessity for it, as everybody seems to have been satisfied. However, it appears that, in consequence of some alteration in regard to the law of adulteration, the manufacturers had altered the description of the cake on their invoices, by leaving out in a sort of label the word "pure." But Mr. Snowsell had not noticed this omission, and he had not noticed that there had been any difference in the manufacture of this cake; but, unfortunately, there was, and this so far as I know was the first case in which such matter was discovered. But when Mr. Iles discovered this, he was naturally very much displeased with the cake which he had got, and he thereupon made a complaint, and brought it before the notice of the Royal Agricultural Society, and thus it was that they thought it right (the cake being used for feeding purposes, and the matter being of the greatest importance to the public) to bring it before them in their report. They did not publish the letters which Mr. Snowsell had written to them, and it is not for me now to say anything about it, because they thought they were carrying out their duty in publishing the documents which they did. Mr. Snowsell thought, as some of the documents suggested that he had some knowledge of the change that had been made in the cake, that it was his duty to himself and his customers to bring this action against the Royal Agricultural Society. Accordingly, the matter has now come into Court, and I, on behalf of Mr. Snowsell, have had an opportunity of making this statement, and Mr. Lockwood, representing the Royal Agricultural Society, has met me very fairly, as I felt sure he would, with regard to this matter; and therefore we agree that the Record shall be withdrawn, and that there shall be an end of the matter.

Mr. LOCKWOOD.—Perhaps your Lordship will allow me to say on behalf of the Royal Agricultural Society for whom I appear, that they have had no interest whatever in this matter so far as this individual Plaintiff is concerned, nor, indeed, my Lord, are they in any way concerned as to any disputes which may arise between this gentleman, who appears to be a retail dealer, and the manufacturers; they must settle those disputes amongst themselves. The Royal Agricultural Society consider they had a duty towards their members, and, indeed, to the farming industry generally; but, as my learned friend has very frankly stated that he recognises that what was done by the Royal Society was done in what they considered to be the performance of the duties which were imposed upon them, it is not necessary for me to say any more upon the matter, so long as it is recognised in public that what was done by the Royal Agricultural Society was done in what they considered the public interest.

Mr. JUSTICE WILLS.—The Record is withdrawn.

Mr. LOCKWOOD.—If your Lordship pleases.

---

## REPORT OF THE EDUCATION COMMITTEE

*On the Results of the Junior Examination of November, 1891.*

THE Committee have to report that the Examination for the Society's ten Junior Scholarships of 20% each for boys between the ages of 14 and 18 took place on November 10 and 11, 1891.

There were forty-five candidates from ten schools, and two candidates unattached, making in all forty-seven entries, the highest total reached since the examination was instituted in 1874. Two candidates who had entered did not present themselves.

2. Of the forty-five actual competitors, eighteen have passed in all four subjects (Agriculture, Chemistry, Mechanics, and Land Surveying) and have obtained the number of marks necessary to qualify them for the Society's Scholarships and Certificates. These will, in accordance with the regulations, be retained until the winners of them shall have spent the ensuing year at school or college, or with a practical agriculturist upon a farm. Two candidates (one from the Devon County School, and one from the Surrey County School) passed in all four subjects, but failed to obtain the minimum total marks necessary to qualify for Certificates. Of the twenty-five other unsuccessful competitors, thirteen failed in one subject, seven in two subjects, four in three subjects, and one in all four subjects. There were five failures in Agriculture, thirteen in Chemistry, seventeen in Mechanics, and eight in Land Surveying.

3. The names of the successful candidates, with the number of marks gained by each, are given in the following Table :—

No. in order of merit	Candidate	Age	School or College	Agriculture, 400 ; pass, 150		Chemistry, 200 ; pass, 75		Mechanics, 200 ; pass, 75		Land Surveying, 100 ; pass, 40		Total, 900 ; pass, 350	
1	Wood, J. R.	17	Aspatia Agricultural College	350	99	127	78	654					
2	McCreath, J.	17	Maybole Public School, N.B.	340	138	118	51	647					
3	Newman, J. H.	17	Surrey County School	270	174	125	75	644					
4	Westley, W. A.	17	Northampton Grammar School	250	159	120	98	637					
5	Armstrong, G. W.	16	Aspatia Agricultural College	285	107	152	71	615					
6	Edgecombe, E.	16	Ashburton Grammar School	315	130	121	47	613					
7	Clayton, E.	17	Aspatia Agricultural College	270	129	88	83	580					
8	Thomas, G. R.	15	Aspatia Agricultural College	300	110	80	77	567					
9	de la Mothe, J. T.	17	Aspatia Agricultural College	240	96	134	88	558					
10	Puddicombe, J.	16	Aspatia Agricultural College	280	107	96	73	556					
11	Endacott, N.	15	Ashburton Grammar School	220	117	119	91	547					
12	Maddicott, W.	16	Aspatia Agricultural College	220	117	122	62	521					
13	Porteous, G. D.	16	Maybole Public School, N.B.	205	144	95	62	506					
14	Johnson, H.	16	Swanley Horticultural College	195	121	100	88	504					
15	Henley, J.	17	Dunn Foundation School, Crediton	225	108	83	67	483					
16	Taylor, C. H.	16	Surrey County School	235	102	75	63	475					
17	Badcock, F. J.	14	Ashburton Grammar School	185	122	73	79	461					
18	Bower, W. G.	17	Surrey County School	150	139	82	80	451					

4. The Examiner in Agriculture, Mr. Primrose McConnell, B. Sc., reports that "the result this year is very much superior to that of former years: there are very few failures, while the average of marks obtained is very high, the honours being pretty evenly distributed among three or four of the schools. This is gratifying when the fact is taken into consideration that the questions set refer as far as possible to the details of practice not usually found in books, so that the knowledge of these displayed indicates satisfactory progress, when compared with the vague replies I have often had on former occasions."

5. The Examiner in Chemistry (Dr. J. Augustus Voelcker, B. A. B.Sc.) reports that "two papers were extremely good. Following these were seven very fair papers, but the remainder were inferior. The majority of the papers showed evidence of particular points, such as formulæ, specific gravities, molecules of water of crystallisation, &c., having been 'got up' very exactly, while many of the more elementary facts were unduly neglected."

6. The Examiner in Mechanics and Natural Philosophy, and in Mensuration and Land Surveying (the Rev. Professor Twisden, M. A.), reports that "the best work in the subject of Mechanics is not as good as the best work of last year, and a good deal of the work, as will be seen from the marks, is very poor. However, about a third of the papers show that the writers have some knowledge of the elements of the subject. Question 5 brought out a good deal of ignorance, but the question was well answered seven or eight times. Question 9 was well answered only three times, but this might, perhaps, have been expected. Question 10 was often not attempted, and was very seldom answered to any purpose. This was a weak point in the examination. A curious mistake was made a good many times, and by boys in more than one school, viz. the same body was said to be acted on by gravity and by its own weight, as if these were two distinct and separate forces, *e.g.* in some answers to the fourth question, Q was said to be acted on (1) by its own weight; (2) by gravity."

7. In Mensuration and Land Surveying, Professor Twisden reports that "the marking is proportionately much higher than in Mechanics, and on the whole the work is very fairly good and accurate. I may mention particularly that question 6, which resembles a question ill done last year, was well done in many cases. Question 1 was in most cases understood. In question 2 very few found the area with a reasonable degree of accuracy, and many did not find it at all. It may be well to notice that the question requires the area to be found from the triangle that has been previously drawn. This direction was seldom attended to. The length of the third side was taken from the drawing, so that the three sides were known, and from them the area was calculated by the well-known formula. This method involves a very long calculation, and therefore is very liable to error. In fact, the result was



seldom correct. Another instance of a perverse choice of long methods occurred in the answers to question 3. Very few saw that when the radius has been found, the area can be found by multiplying half the radius by 1000. I may add that in the answers to this question no attention was paid to the point that the area was to be found true to the nearest square inch."

8. The results of the Examination as a whole are above the average of the last seven years, and may be considered as satisfactory, especially as regards the large proportion of successes in Agriculture. The Committee would, however, point to the fact that as many as seventeen candidates failed in Mechanics, and that but for failure in this subject five other candidates would have qualified for Certificates if not for Scholarships.

JOHN TREMAYNE,  
*Chairman.*

December 8, 1891.

EXAMINATION IN AGRICULTURE.

MAXIMUM NUMBER OF MARKS, 400. PASS NUMBER, 150.

*Tuesday, November 10, 1891.*

*(Three hours allowed.)*

1. Explain how draining improves land.
  2. Describe the making of a bare fallow.
  3. Describe the cultivation of the potato crop, from the preparation of the land to the raising of the tubers.
  4. Explain the influence of food on the quantity and quality of milk yielded by a cow.
  5. State some of the general points attended to in selecting rams for breeding purposes.
  6. State approximately the number of carts, ploughs, rollers, harrows, corn-drills, horse-hoes, cultivators, reapers, mowers, and horse-rakes required on a farm of 300 acres of mixed husbandry.
  7. Sketch a good arrangement of the parts of a double cow-stall, giving dimensions.
  8. In milking a cow explain the advantages and disadvantages of the *stripping* manner of milking, the *squeezing* or *neivling*, and also the *wet* and the *dry* methods.
  9. Give a ration suitable for an ordinary working farm-horse for summer feeding, and also one for winter.
  10. Write a short paper on the variations in the climate of different parts of Great Britain, giving some details regarding rainfall, temperature, and elevation.
-

## EXAMINATION IN ELEMENTARY CHEMISTRY.

MAXIMUM NUMBER OF MARKS, 200. PASS NUMBER, 75.

Tuesday, November 10, 1891.

(Three hours allowed.)

1. Describe two processes for the preparation of oxygen gas. Name the principal properties of the gas.
2. From what salt is nitric acid ( $\text{HNO}_3$ ) commonly prepared? From 100 grammes of the salt, how much of the acid can be obtained?
3. What is meant by an element being mon-atomic, di-atomic, tri-atomic, &c.? Give an example of each.
4. A solution contains chloride of barium, chloride of calcium, chloride of magnesium: how would you prove the presence of the respective elements?
5. Distinguish between the *ash* (mineral matter) left—
  - (a) when wood is burnt.
  - (b) when bones are burnt.
6. A crystalline powder, purporting to be "blue vitriol," is believed to have some "green vitriol" mixed with it. Define the terms "blue vitriol" and "green vitriol," and indicate how you might detect the presence of the latter in the mixture.
7. How does sulphur occur in nature? Describe the allotropic modifications of sulphur, and say how they are severally obtained.

## EXAMINATION IN MENSURATION AND LAND SURVEYING.

MAXIMUM NUMBER OF MARKS, 100. PASS NUMBER, 40.

Wednesday, November 11, 1891.

(Two hours allowed.)

1. What is meant when a plan is said to be drawn to a scale, the representative fraction of which is  $\frac{1}{100000}$ ?  
If the plan of an estate were drawn to this scale, how many yards apart on the ground are two points, which are shown on the plan by two points 5.25 inches apart?
2. In a triangle ABC the sides AB and AC are respectively 5,275 and 4,160 feet long, and the angle BAC is  $71^\circ 10'$ ; draw the triangle to a scale of 1 inch equal to 1,000 feet; note the length of BC, and the number of degrees in the angles B and C. Find also from the drawing the number of acres, &c. in the triangle.
3. The circumference of a circle is 1,000 inches; find (a) the length of its radius, (b) its area, working with sufficient accuracy to ensure finding its area to the nearest square inch. ( $\pi = 3.14159$ .)
4. How many gallons of water are there in a pipe (kept full) a mile long and 3 inches in internal diameter? If water is delivered from the pipe at the rate of 5,000 gallons an hour, with what velocity does the water move in the pipe? (A gallon contains 277.274 cubic inches.)
5. A and B are two points 5,500 yards apart; B is  $37^\circ$  to the north of east from A: using a scale of 1 inch equal to 1,000 yards, find by construction how many yards B is north, and how many yards it is east, of A.
6. A, B, C are three points in order on the ground; they are respectively 20 feet, 15 feet, and 18 feet above the datum line; from A to B horizontally is 200 feet, and from B to C is 300 feet; show the points and the slope of the ground between them in a diagram, using 1 inch equal to 10 feet for a vertical scale, and 1 inch equal to 100 feet for a horizontal scale.  
The level is placed between B and C, and the back-reading of the levelling staff at A is 2 feet 7 inches; find the back-reading of the staff at B, and the fore-reading of the staff at C. Draw a line on your diagram to show the line along which the observer looks in taking the levels.

## EXAMINATION IN MECHANICS AND NATURAL PHILOSOPHY.

MAXIMUM NUMBER OF MARKS, 200. PASS NUMBER, 75.

Wednesday, November 11, 1891.

(Three hours allowed.)

1. State where the centre of gravity is situated in the case of any two simple figures.

Mention any one property of the centre of gravity of a body.

A ring can just slide freely along a rod (A B) of uniform density; the weights of the ring and rod are equal; where must the ring be placed that the centre of gravity of the whole body (*i.e.* of rod and ring) may be five-eighths of A B from A?

2. Define the moment of a force with respect to a point.

Draw a square A B C D; in B C take a point O, such that B O is three-fourths of B C, and suppose that the square can turn freely in the plane of the paper about O; let forces P and Q act from A to B and from A to D respectively; if P is a force of 20 units, how many units must there be in Q if the forces are in equilibrium? The forces being in equilibrium, what is the magnitude of their resultant, and along what line does it act?

3. When a body is placed on a smooth horizontal table and left to itself, what forces act on it, and what are the conditions of the forces being in equilibrium?

If the table stands on three legs, and the body is placed first at one point on it, then at another, what change is produced in the forces that support the table?

4. When is work done by a force, and how is the work measured?

Two bodies (to be treated as particles) are connected by a thread; one of them (P) is placed on a smooth horizontal table, the other (Q) hangs over the edge; Q descends, drawing P along the table; what forces act on the bodies respectively, and which of the forces do work?

5. In the last question let the mass of P be 20 lb., and let that of Q be 5 lb.; if Q descends through three feet, what is the kinetic energy of each body in foot-pounds, and what is the velocity of either body in feet per second? ( $g = 32$ .)

6. A body is partly immersed in water; state the rule for determining the magnitude and line of action of the resultant of the fluid pressures on it.

The specific gravity of a body is 0.8, and its volume is 100 cubic inches; how many cubic inches of its volume are immersed when it floats in still water?

7. Describe briefly the forcing-pump, and show in diagrams the valves (a) when the piston or plunger is being raised, (b) when it is being forced down.

The plunger has a section of 36 square inches, and at each stroke is worked through two feet; the reservoir is 100 feet above the plunger; find (a) the number of foot-pounds of work done at each stroke, (b) the force exerted on the plunger when the water is being forced up.

8. Define the freezing and boiling points of an ordinary mercurial thermometer. In what sense can these points be regarded as fixed points?

Describe the graduation of Fahrenheit's and of the Centigrade thermometer.

9. Define the mechanical equivalent of heat, and state its numerical value.

The mass of a body is 3 lb., and it is moving at the rate of 1,000 feet a second; what is the numerical value of its kinetic energy? If that kinetic energy were converted into heat (*e.g.* by impact), by how many degrees would that quantity of heat raise the temperature of a gallon of water? (A gallon of water weighs 10 lb.)

10. Describe briefly Watt's Parallel Motion, and its application to the steam-engine.

## REPORT ON THE EXPERIMENTS WITH *BOUILLIE BORDELAISE.*

THE experiments undertaken at the request of the Board of Agriculture, by the Royal Agricultural Society, for the purpose of determining the efficacy of *Bouillie Bordelaise* for the prevention or cure of the potato disease, have been carried out in six localities, selected so as to represent the different conditions under which the potato is cultivated in England. Three were chosen in the West—one being on the farm of Mr. H. Hine at Poughlett, Plymstock, Devonshire, another on the farm of Mr. W. Marsh at Pen-y-bedd, Carmarthen, and the third on the farm of Mr. Smith at Ludlow, Knutsford, Cheshire; two were chosen in the East of England—one on the farm of Mr. Blagden at Epworth, in the north of Lincolnshire, and the other on the farm of Mr. H. L. Cobb at Milton, Sittingbourne, Kent; and the remaining locality was on the farm of Messrs. Malden, at Cardington, Bedfordshire. To the gentlemen named the Society are indebted for their efficient aid in carrying out the experiments, often at some inconvenience.

The assistance of Mr. Edmond Riley of The Weir, Hessle, Hull, was secured to take charge of the practical carrying out of the experiments. Under the direction of Mr. Whitehead and Dr. Voelcker, Mr. Riley saw to the preparation of the mixture employed, and to its proper application to the various crops, and in his visits to the localities he observed the progress of the experiments. The following report is largely based upon Mr. Riley's statements and letters. When the disease was supposed to have appeared at any of the stations, specimens of the affected plants were forwarded to the Consulting Botanist, and the presence of the parasitic fungus was determined by him or by his son, Mr. J. B. Carruthers.

The experimental plots were portions of large potato fields which had been already planted. The varieties to be operated upon were not selected by the Society, but the particular variety planted by the farmer for his ordinary crop was made the subject of experiment.

The *Bouillie Bordelaise* used consisted of 20 lb. of sulphate of copper, 10 lb. of unslaked lime, and 100 gallons of water. The sulphate of copper was put in a bag, which was suspended over night in water until the sulphate was completely dissolved. The lime freshly slaked with water and kept till it was cooled was poured into the blue-stone solution through a sieve, which caught any stones, hard lumps, &c. The liquid was kept continually stirred as the lime was being added.

Mr. Riley warns purchasers of sulphate of copper against a spurious mixture supplied from Scotland, which on analysis was found to be half sulphate of iron. The bright blue of the sulphate of copper (blue-stone) enables one easily to distinguish it from the

green crystals of the sulphate of iron; a mixture of the two sulphates reduced to powder has a very different colour from the blue of the copper sulphate.

The "Eclair" machine<sup>1</sup> was employed in distributing the mixture, which it does in a fine spray, wetting, when properly applied, both surfaces of the leaf.

The quantity of the mixture applied varied from 60 to 115 gallons per acre, according to the amount of foliage. No difficulty was experienced in getting an ordinary farm labourer to use the Eclair satisfactorily. The cost of labour in applying the mixture, including the expenses of carrying water, tubs, &c., to the field, amounted to 5s. an acre for each dressing, estimating the day's wage at 3s. The mixture applied cost, on an average, 3s. 6d. an acre, the difference in the price noted in the Table being due to the different charges for carriage. The total ex-



The "Eclair" Machine.

expense consequently came to, on an average, 8s. 6d. per acre for a single dressing. This does not include the original cost of the Eclair, which is sold in London for 35s.

The mixture was first applied early in July to the plots at each station indicated by A in Table I. on page 831. These plots were treated with the view of seeing how far early and repeated applications might prevent the disease in the plots, should it afterwards attack the rest of the crop in the fields in which they were situated. A second application was made after the middle of the month, still before any disease had made its appearance. In two localities (Kent and Bedford) the mixture was applied a third time towards the middle of August, when the disease had made its appearance in the fields.

The plots marked B in the table were treated with the view of seeing how far a single application of the mixture might arrest or cure the disease in potatoes which had already been attacked. One

<sup>1</sup> For a description of the "Eclair" machine, see pages 232-3 of the present volume of the Journal.

hundred gallons were applied to the acre. In Bedfordshire this dressing was applied on August 11, in Kent on the 12th, and in Devonshire on August 14. The disease was later in its appearance in Cheshire, where the "curative" application was not made till August 28. No "curative" application was made in Lincolnshire, and the disease did not make its appearance in the field at Carmarthen, and this locality is consequently excluded from the following table.

No mixture was applied to the C plots at any of the stations. Left undressed, they were employed as standard plots to test the gain or loss from the application of the mixture to the neighbouring dressed plots A and B.

The table shows a distinct improvement in the crops as the result of the application of the mixture, in all the localities except Cheshire. The variety experimented on there was the "main crop," which Mr. Smith says is the most tender variety he grows, being blackened by the first frost. Mr. Riley ascribes the exceptional result in Cheshire to the injury caused to the plants by the application of the mixture. It shrivelled up the leaves, turning them brown, and it so affected the plant that it did not flower, though flowers were abundant on the untreated crop.

The smallest gain in the produce was obtained in Devonshire, where there was a heavy crop not seriously diseased. The principal increase was in plot B, though it had a larger proportion of diseased potatoes than either of the other plots. When Mr. Riley applied the mixture to plot B on August 14, he observed that the plants on plot A, which had been twice dressed (June 28 and July 15), had grown fully six inches since the last dressing, and that the new growth had been attacked by the disease. An application of the mixture a week before his visit might, he thinks, have prevented the attack.

The largest proportion of diseased potatoes were met with in Bedfordshire, and the mixture has here obviously benefited the plants to which it was applied.

The most remarkable results were secured in Kent, where the treated plots yielded much larger crops with a smaller proportion of diseased tubers than the undressed.

The most obvious deduction from the table is that the application of the mixture did not prevent the disease anywhere, but a glance at the percentages of the diseased potatoes in the various plots shows that the untreated plots suffered most heavily, though in some of the cases the difference was very trifling. In Cheshire, Devonshire, and Lincoln the amount of disease was very small, and the differences scarcely appreciable. No deduction can be drawn from them as to any influence on the disease from the application of the mixture. It is somewhat different in the other two districts—Kent and Bedford—where the attack of the disease was more severe. In the untreated plot C, in Kent,  $6\frac{1}{2}$  per cent. of diseased potatoes were found, while in plots A and B only  $1\frac{1}{2}$  per cent. were present. In Bedford, plot C had 12 per cent. diseased potatoes,

TABLE I.—RESULTS OF THE EXPERIMENTS ESTIMATED PER ACRE.

	DISEASED TUBERS			SOUND TUBERS						Net loss		
	Actual weight	Per cent.	Actual weight ton cwt. qr. lb.	Influence of dressing		Value of gain		Value of loss	Total cost of treatment		Net gain	
				Gain ton cwt. qr. lb.	Loss ton cwt. qr. lb.	£ s. d.	£ s. d.					£ s. d.
<b>DEVONSHIRE</b> :—												
Loam on limestone.	A 0 4 2 0	1.6	13 8 3 5	0 6 2 0	—	—	1 2 9	—	0 15 3	0 6 6	—	—
Variety, "Imperial."	B 0 5 2 3	2.0	14 0 0 16	0 17 3 11	—	—	3 2 5	—	0 8 6	2 13 11	—	—
"Top."	C 0 5 0 10	2.0	13 2 1 5	—	—	—	—	—	—	—	—	—
<b>CHESHIRE</b> :—												
Sandy soil on gravel.	A 0 0 1 12	.21	8 3 1 16	—	1 9 1 8	—	—	—	0 17 0	—	—	5 5 0
Variety, "Main Crop."	B 0 0 0 14	.06	9 7 3 20	—	0 4 3 4	—	—	—	0 8 6	—	—	1 2 10
C 0 0 2 8	.28	9 12 2 24	—	—	—	—	—	—	—	—	—	—
<b>LINCOLNSHIRE</b> :—												
Warp on clay.	A 0 1 2 0	.6	12 8 0 0	1 1 1 4	—	Not treated	3 3 10	—	17 0	2 6 10	—	—
Variety, "Imperial."	B 0 2 3 12	1.2	11 6 2 24	—	—	—	—	—	—	—	—	—
C 0 2 3 12	1.2	11 6 2 24	—	—	—	—	—	—	—	—	—	—
<b>KENT</b> :—												
Loam on clay.	A 0 4 0 0	1.6	12 12 0 0	3 18 0 0	—	—	13 13 0	—	1 5 6	12 7 6	—	—
Variety, "Regent."	B 0 4 0 0	1.7	11 4 0 0	2 10 0 0	—	—	8 15 0	—	0 8 6	8 6 6	—	—
C 0 12 0 16	6.5	8 14 0 0	—	—	—	—	—	—	—	—	—	—
<b>BEDFORDSHIRE</b> :—												
Gravelly soil.	A 0 1 0 0	.5	8 18 3 12	1 12 3 12	—	—	4 18 7	—	1 4 0	3 14 7	—	—
Variety, "Daniel's."	B 0 10 1 4	5.5	8 13 1 20	1 7 1 20	—	—	4 2 3	—	0 8 6	3 13 9	—	—
C 1 0 0 0	12.0	7 6 0 0	—	—	—	—	—	—	—	—	—	—

A. Plots treated twice. B. Plots treated after disease had appeared. C. Plots not treated.

while in plot A there were only  $\frac{1}{2}$  per cent., but in plot B the proportion rose to  $5\frac{1}{2}$  per cent. Further and more decided experiments are, however, needed before trustworthy conclusions can be arrived at as to the influence of the mixture on the fungus causing the disease.

It is, further, obvious from the table that the use of the mixture has secured a larger crop. In each case, except Cheshire, there is a distinct advantage, and in most of the plots a considerable gain stands to the credit of the mixture.

The plots at Carmarthen were not attacked by the fungus causing the potato disease, but an obscure malady, locally called "sea-blight," made its appearance suddenly. A small black spot showed itself on the leaf, which rapidly spread, until in a fortnight every leaf was dried up and dead. The dressing had a beneficial effect, which showed itself in the dressed plot keeping green for some weeks after the foliage of the potatoes in the rest of the field had been destroyed.

TABLE II.—RESULT OF THE EXPERIMENT AT CARMARTHEN, ESTIMATED PER ACRE.

—	Plot	Actual weight				Gain				Value of gain			Total cost of treatment			Net gain		
		t.	c.	q.	lb.	t.	c.	q.	lb.	£	s.	d.	£	s.	d.	£	s.	d.
Sandy, warp, or clay Variety, "Magnum Bonum" {	A	10	10	1	4	2	5	2	20	7	19	10	0	17	6	7	2	4
	C	8	4	2	12	—	—	—	—	—	—	—	—	—	—	—	—	—

A. Plot dressed. C. Plot not dressed.

The dressing had a marked effect in this single experiment, no doubt due to what Mr. Riley observed, the continuance of the plants in active life for weeks after the untreated plants were all dead.

TABLE III.—STRENGTH AND QUANTITY OF MIXTURE EXPERIMENTS.

Station	Plot	Diseased Tubers per acre		Sound Tubers per acre																			
		Actual weight	Per cent.	Actual weight	Gain by treatment	Value of gain	Cost of treatment	Net gain															
		t.	c.	q.	lb.	t.	c.	q.	lb.	£	s.	d.	£	s.	d.	£	s.	d.					
<b>KENT:—</b>																							
Loam on clay Variety, "Regents" Plots M, N, and O, dressed July 8 and 23	M	0	2	1	4	9	11	16	0	0	3	2	0	0	10	17	0	0	14	0	10	3	0
	N	0	4	2	8	2.4	9	6	0	0	0	12	0	0	2	2	0	0	12	0	1	10	0
	O	0	3	0	16	1.2	8	18	2	8	0	4	2	8	0	15	0	0	12	10	0	3	2
	P	0	12	0	16	6.5	8	14	0	0	—	—	—	—	—	—	—	—	—	—	—	—	—
<b>BEDFORD:—</b>																							
Gravelly soil Variety, "Dumfries" Plots M, N, and O, dressed July 10 and 24	M	0	5	2	24	3.3	8	4	3	12	0	18	3	12	2	16	7	0	14	0	2	2	7
	N	0	8	0	0	4.8	7	18	1	4	0	12	1	4	1	16	10	0	12	0	1	4	10
	O	0	9	0	0	5.1	7	19	2	24	0	13	2	24	2	1	2	0	12	10	1	8	4
	P	1	0	0	0	12.0	7	6	0	0	—	—	—	—	—	—	—	—	—	—	—	—	—

Treatment each time of dressing

{ M. 15 lb. copper sulphate, 5 lb. lime, 100 gall. water—at 80 gall. per acre.  
N. " " " " " " " " " "  
O. 20 " " " " " " " " " "  
P. The plot for comparison, not dressed.





The dressing applied on all the plots was one of 20 lb. sulphate of copper, 10 lb. of quick lime to 100 gallons of water. I made use of one of the hand hop-washers we use in Kent, and with slight modifications this machine is well adapted for the purpose.

The first application was made on July 28, to plots of Beauty of Hebron, in which the disease had just appeared, and to Magnums, which were then perfectly free from it. On August 5, I treated the following varieties in another field, viz.: Imperators, Sutton's Abundance, and Chancellors, in which indications of disease were appearing. It may be interesting here to note that the first disease I observed amongst the Imperators was on plants immediately surrounding one plant of Beauty of Hebron, and which being itself badly affected had contaminated its more hardy neighbours.

I have not given the weight of diseased tubers in the following table. In the Beauty of Hebron plots, however, 12.5 per cent. of potatoes were affected in the case of the untreated, as against 2.6 per cent. where dressed. These were dug early, September 2, and we were therefore able to weigh the unsound tubers, but the other varieties were raised October 28 and 30, when the diseased tubers had completely rotted away. The results obtained were as follow:—

Variety	Size of plot in poles	Dressed plot		Undressed plot		Increase	
		Per plot	Per acre	Per plot	Per acre	Per acre	Percent.
"Beauty of Hebron"	20	c. q. lb. 25 0 26	t. c. q. lb. 10 1 3 12	c. q. lb. 23 1 20	t. c. q. lb. 9 7 1 20	t. c. q. lb. 0 14 1 20	7.7
"Abundance" . . . .	3	4 0 7	10 16 2 18	3 1 16	9 0 3 22	1 15 2 24	16.6
"Chancellor" . . . .	4	5 3 25	11 18 3 20	4 3 11	9 13 3 20	2 5 0 0	23.2
"Magnum Bonum" . . .	5	6 3 1	10 16 1 4	4 1 16	7 0 2 8	3 15 2 24	58.75
"Imperator" . . . .	8	14 2 22	14 13 3 20	10 3 1	10 15 0 20	3 18 3 0	36.6

<sup>1</sup> The Magnum plot was sprayed a second time on August 15.

In spite of the unfavourable weather following the applications, rain prevailing throughout the month of August, the striking efficacy of the remedy is apparent. The advantage is not wholly or even chiefly derived by the prevention of disease in the tubers, but rather from the prolongation of the life of the plant which ensues from the application. Instead of being cut off when the crop is but half grown, time is allowed the plant to fully develop its tubers, so that hardy and late kinds, such as Imperator and Magnum, benefit more than the Hebrons, which are much more susceptible to blight. Hebrons were the only variety that suffered to any extent in the tubers with me this season, although all the varieties had their haulms destroyed. Hebrons, if planted early, should, to a great extent, have obtained their growth before disease appears. The preservation of the bine in vigorous life accounts for the large crop we dug where the copper solution was used on the late varieties.

It appears most important that the spraying should be very thorough. There should be no stint in the quantity of the dressing applied, so that every leaf if possible may receive its share. I am of opinion that it should not be applied earlier than the period at which disease usually appears. In Kent we have it about the last week in July. Otherwise a second spraying may be necessary. The lime should be kept in suspension by stirring the liquid. When properly done it appears to me that one application will be found sufficient.

The general outcome of the experiments appears to be that the *Bouillie Bordelaise* has not prevented the disease in any of the localities, but that it has decreased the amount of disease in the plots to which it has been applied, and has decidedly increased the yield of tubers. A single year's work does not, however, supply data on which generalisations of any permanent value can be based.

CHARLES WHITEHEAD,  
*Chairman.*

December 8, 1891.

---

---

## ANNUAL REPORT FOR 1891 OF THE CONSULTING CHEMIST.

THE past year has shown a falling off to some extent in the number of samples submitted to the Consulting Chemist by members of the Society. The total number of analyses made on their behalf for the twelve months ending November 30, 1891, has been 1,358 as against 1,447 in 1890. The most marked reduction has been that in linseed and other feeding cakes, whilst in manures there has been an increase. A large number of waters form part of the year's total.

On February 1, I returned to my duties after a thirteen months' residence in India, whither I had gone by the Council's kind permission, and after selection by Sir James Caird, for the purpose of reporting to the Government of India as to the possibility of improving the agriculture of that vast country by scientific means. My report on that mission will very shortly be ready, and meantime I have contributed to the March number of the Society's Journal a paper on "Indian Agriculture in its Physical Aspects."

Perhaps the chief feature of the year, in so far as the more immediate and every-day work of the laboratory is concerned, has been the agitation for better protection against the fraudulent sale of fertilisers and feeding-stuffs. Although the crowded state of business in the House of Commons compelled the postponement of the Bill which Mr. Chaplin, as President of the Board of Agriculture, undertook to introduce, it is tolerably certain that this will come on for discussion during next Session.

The Royal Agricultural Society will welcome a measure which deals fairly with a matter of so much importance to the farming community, and which proceeds in the direction in which the Society has for so long been working. Whether from this cause or from others, it is satisfactory to note that, although the actual number of linseed and other cakes sent for analysis has been less, there has been a very general improvement, more especially in those cakes sold as "linseed" cakes. Where members have adopted the advice given, and have asked for "pure" cakes, and insisted upon the signing of the form of contract note issued by the Society, it is but rarely the case that purchases have been found to be inferior. This may, indeed, be

the reason that fewer members have thought it necessary to have a confirmatory analysis made. It is also a matter of considerable satisfaction that some firms have not hesitated to openly avow their readiness to sell cakes according to the Society's form of guarantee.

On the other hand, where cakes have been purchased under the vague description of "oil-cake," it has been generally found that these have gone from bad to worse, and have become more than ever the media for conveying into stock the refuse sweepings and dirt of the mills.

It cannot be said that any fresh special adulterant has been brought to light this year, but mention may be made of an instance where linseed-cake was found to have been adulterated with *Bassia* (*Bassia latifolia*) seed, the husk of which has an intensely acrid and bitter taste. This taste it imparts to the cake with which it is mixed, and renders it a very undesirable one to use for feeding purposes. Also it is well to mention, by way of caution, that more than one case has been brought to my notice in which decorticated cotton-seed meal has been found to contain the husk of castor-oil beans. In one instance a number of animals had been killed by the use of this meal, while many others were made very ill, though they finally recovered. Besides containing the castor-oil husk referred to, the meal was stale and distinctly acid.

#### FEEDING STUFFS.

*Linseed-cakes.*—Until the month of October the price of linseed-cake continued fairly regular—viz. from 7*l.* 15*s.* per ton to 8*l.* 10*s.* for good-quality cake. In October, however, prices took a sudden rise, consequent, partly on the low returns obtained for oil, and, more immediately, on the prohibition of the export of linseed from Russia. From 8*l.* 10*s.* per ton the cost rose to 9*l.* 10*s.*, 9*l.* 15*s.*, and even 10*l.* per ton. As cotton-cake, both undecorticated and decorticated, had also risen simultaneously—the latter, indeed, being hardly obtainable—little relief for feeders of stock could be gained by the substitution of cotton for linseed cake.

Occasionally an exceptionally hard-pressed and low-quality linseed-cake has been sent to me. Of such a one I give an analysis (A) in the following Table, placing in comparison with it those of two high-quality cakes.

	A	B	C
Moisture . . . . .	8·55	14·30	11·38
Oil . . . . .	5·73	15·30	20·96
<sup>1</sup> Albuminous compounds . . . . .	35·50	25·50	33·19
Digestible fibre, mucilage, &c. . . . .	37·10	30·64	24·13
Woody fibre . . . . .	7·87	7·96	6·30
Mineral matter (ash) . . . . .	5·25	6·30	4·04
	100·00	100·00	100·00
<sup>1</sup> Containing nitrogen . . . . .	5·68	4·08	5·31

A was sold in December 1890 on the London Corn Exchange at 6*l.* 15*s.* per ton. The sender of the sample said his cows would not eat it. I found it to be one of the hardest cakes I had ever examined, and considered that the farmer's cows had shown much discretion.

B was a perfectly pure cake, costing then (February 1891) 8*l.* 10*s.* a ton delivered, a not excessive price as the market stood at the time.

C was an exceptionally rich and also pure cake, costing (April, 1891) 10*l.* per ton. No one understanding these analyses, even slightly, can fail to see that the inducement of a lower price may be very dearly bought; and to this I would add that the deprivation of a linseed-cake of so much oil as was the case with the sample A cannot be effected without rendering it excessively hard, indigestible, and, it may be, even dangerous to use.

*Cotton-cakes.*—Undecorticated cake experienced in October 1891 a similar rise in price to linseed-cake, going from 4*l.* 15*s.* and 5*l.* per ton to 5*l.* 15*s.* and 6*l.* Once again I have to give a warning against the use of certain foreign-made cotton-cakes. These are mostly of the kind called "Brazilian," or are of Marseilles manufacture. They present a peculiar appearance, unlike that of well-made English cake; they are generally coated with a good deal of hair from the horse-hair bags in which the seed is pressed, and the husk is decidedly coarse; often they are acid in character, and not unfrequently bits of metal, iron nails, &c., are found in them. Such was the case when a member of the Society recently sent me a sample of this class of cake. He complained that four young calves had died, and a valuable bull had been taken ill. On examining the cake, pieces of sacking were found in it and quite a small collection of bits of old iron. Another objection to undecorticated cotton-cakes still recurs from time to time—viz. the presence of cotton-wool, which has not been properly removed from the seed. I have often drawn attention to this, having had during my experience many clearly proved cases of its having caused damage by collecting, together with the fibre, in the stomachs of animals. I do not say that this is bound to occur where such a "woolly" cake is used, but I unhesitatingly say it is likely to happen, and thus it must be always considered dangerous. It is well known, however, that individual animals, if fed cautiously at first, may accustom themselves to food which, under other circumstances, or if too freely fed to them, would prove injurious, or even fatal. Much depends, too, upon the individual constitution and surroundings of the animal. Thus, in India it is no uncommon sight to see the whole cotton-seed, with a quantity of wool still adhering, fed to bulls and working bullocks. I well remember being struck with this when I first saw it, and I could not help wondering what might be the fate of our highly-bred bulls at home if this were given to them. But one has to consider the difference of the surroundings, the fact that in the one country the cattle are kept for working, but not in the other; then, too, the dry and hard nature of the usual food of Indian cattle and other

determining features must be borne in mind. A member of the Society sent me, soon after my return, a sample of cheap cotton-cake which he had bought at 3*l.* 7*s.* 6*d.* per ton at his station. The cake was old and full of cotton-wool, and in my opinion only fit for manure. However, the sender assured me that his store sheep had been feeding on it and seemed to be thriving. That they might accustom themselves to it is quite probable, but experience fully proves that it is highly injudicious to use such a food.

*Cotton-seed Meal.*—Several samples of whole seed, simply ground, but with the oil not extracted, have been sent to me; but in nearly every case the meal has been open to the objection of having a lot of cotton-wool left with the seed. They have generally contained from 20 to 22 per cent. of oil.

*Decorticated Cotton-cake.*—In No. VII. of the Journal R.A.S.E. (1891), I published an account of a two years' experiment on the comparative feeding values of decorticated and undecorticated cotton-cake, the result in each case being distinctly in favour of the former. I am pleased to notice that considerable attention has been directed to these experiments, and it is only to be regretted that, with its value now so fully acknowledged, the decorticated cake has been so hard to get. From the middle of October up to the close of November there was hardly any obtainable anywhere. The price of it, which at the beginning of the year was 6*l.* 10*s.* per ton, rose in October to 8*l.* 5*s.* per ton.

*Earth-nut Cake.*—This cake, made from the seeds contained in the underground pod of *Arachis hypogea*, has been suggested as a substitute for decorticated cotton-cake, especially when the price of the latter rises, and when supplies of it are short. The seed is grown largely in India, principally in the Madras Presidency. It is also grown in parts of Africa, America, &c. The oil is expressed by the natives, and is used largely in the South of Europe for adulterating olive oil. The pressed cake is used, partly for feeding cattle in India, and partly for exportation. Up to the present not much has reached England. Its tendency to turn sour and rancid may militate against its success, but it is intended to make a trial with it at the Woburn experimental farm. There are two kinds met with—the one consisting solely of the seeds, and called “decorticated” cake; the other made from the seeds and pods together, and called

	Decorticated cake	Undecorticated cake
Moisture . . . . .	8·10	9·80
Oil . . . . .	7·26	6·50
<sup>1</sup> Albuminous compounds . . . . .	47·81	47·31
Digestible fibre, starch, &c. . . . .	25·02	19·28
Woody fibre . . . . .	4·86	10·26
<sup>2</sup> Mineral matter (ash) . . . . .	6·95	6·85
	<hr/> 100·00	<hr/> 100·00
<sup>1</sup> Containing nitrogen . . . . .	7·65	7·57
<sup>2</sup> Including sand . . . . .	2·85	2·85

“undecorticated” cake. The price of the latter (7*l.* 5*s.* a ton) does not, however, hold out particular inducements to buyers so long as decorticated cotton-cake can be obtained. The analyses at the foot of the preceding page are of a sample of the decorticated cake received by me from India direct; and of one of the undecorticated cake sent from the Argentine State.

*Feeding Meals.*—As an instance of what so-called “feeding meals” may sometimes be, I give the following case of one which was sent to me by a member who stated that it was called “special feeding-meal,” but that neither sheep nor cows would eat it. It cost 6*l.* 10*s.* a ton, and was guaranteed to be “absolutely pure.” On analysis of it I found it to contain no less than 6·10 per cent. of fine sandy matter.

### MANURES.

Passing from feeding materials to manures, it is well to remark that the past season has been a very unprofitable one for manufacturers, and that while they have experienced keen competition and less demand, farmers have, on the other hand, had the advantage of purchasing artificial manures at almost unaltered prices throughout, and such as can hardly be remunerative to the merchants. If farmers prefer to buy compound manures sold under various descriptions, they must of course take their chance, or rely on the reputation of the firms they deal with; but for those who purchase such staple commodities as mineral superphosphate, bone-meal, dissolved bones, sulphate of ammonia, nitrate of soda, kainit, &c., there can be no complaint either as to any difficulty in procuring these, or as to having to pay dearly for them.

*Superphosphate (Mineral).*—The price for this, of the ordinary 26–28 per cent. “soluble” quality, has been steady throughout—viz. from 3*l.* to 3*l.* 5*s.* a ton. A few cases have occurred throughout the year where low-quality samples, containing only 15 or 17 per cent. of soluble phosphates, were met with; but this has been quite the exception.

*Basic Slag or “Basic Cinder.”*—The quality of the samples sent to me has been good in almost all cases. The results have been well up to the guarantees given, and the samples have, as a rule, been in a finely-powdered condition.

*Dissolved Bones.*—These, when sold under a guarantee of being “pure,” have generally been found to prove so; although somewhat higher prices may have been asked, I am sure it will pay farmers better to get such a material, and, if they so please, mix mineral superphosphate with it, than to purchase the various mixtures sold under the names of “Dissolved Bone Compound,” “Dissolved Bone Manure,” &c., which contain a more or less uncertain amount of bone in their composition. Manufacturers also are, I think, turning more attention to the making of genuine dissolved bones in a form in which it can be readily sown.

*Bone-meal.*—As is known, large supplies of bone-meal are

shipped from India, principally from the ports of Bombay, Karachi, and Calcutta, inasmuch as the religious prejudices of the natives prevent them from making any serious attempt at utilising bones as manure on their own lands. English firms have now established extensive mills in India for the purpose of grinding the bones which are collected over the country, and for reducing them to the various stages of fineness according to which they are graded and sold. It was not to be expected that the English merchants would be left to drive their profitable trade alone, and Parsee merchants and others not hampered by religious scruples have carried on an active opposition. Not content with the legitimate profits to be derived from the trade, some of the native merchants have sought to increase their returns by a practice which is unfortunately not unknown in this country either—viz. that of resorting to adulteration. Before leaving India I had the advantage, through the kindness of an English firm (Messrs. Croft, Wells and Co., of Bombay, Calcutta, and Karachi), of seeing the extensive mills they had erected near Bombay, also of inspecting the enormous supplies of bones collected, and of the methods of grinding and grading them. The arrangements were very complete, and a high quality of bone was sent out. But I also saw, on the day following, not here, but at one of the docks outside Bombay, what I was *not* meant to see—viz. the practice of adulteration of bone-meal with shell-sand, lime, &c., as carried on by certain of the native merchants. It is true that I was somewhat unceremoniously ejected from the premises when my true character was suspected, but not before I had been able to effect my purpose and had seen the heaps of sand and lime, and the mixture of these with the bone-meal. So extensively has this practice been carried on that the former good reputation enjoyed by Indian bone-meal has suffered considerably. Here in England we are apt to speak and think of the “simple” native, but experience has told others besides myself that where there are any “tricks” to be learnt, the native will not be behind the unscrupulous ones found among his European brethren. Accordingly, it is well to point out that, in the matter of Indian bone-meal, it is necessary for purchasers to secure themselves by obtaining a definite guarantee, such as well-known English importers give, and not to trust to the “simplicity” of the native. I append analyses of three different materials which I obtained in India, and which are used for the purpose of adulterating bone-meal in that country.

	A	B	C
Sand . . . . .	12.50	28.65	30
Lime . . . . .	43.78	33.23	40.43
Magnesia . . . . .	1.35	—	20.00
Oxide of iron and alumina . . . . .	4.78	7.65	2.30
<sup>1</sup> Carbonic acid . . . . .	29.64	24.64	28.55
Alkalies . . . . .	4.70	} 5.83	4.05
Water . . . . .	3.29		4.37
	100.00	100.00	100.00
<sup>1</sup> Equal to carbonate of lime	67.36	56.00	64.89



None of these samples contained any appreciable quantity of phosphate of lime. B was virtually nothing but shell-sand, C was quite white, and seemed much like finely powdered magnesian limestone, whilst A appeared to be a mixture of B with some amount of C.

The following is the analysis of a sample of Indian bone-meal which was sent to me, and which I found to be low in quality, owing to adulteration with some material kindred to the above, and composed mainly of carbonate of lime and sand :—

Water . . . . .	7.57
<sup>1</sup> Organic matter . . . . .	24.22
Phosphate of lime . . . . .	46.24
Carbonate of lime, &c. . . . .	15.43
Sand . . . . .	6.54
	100.00
<sup>1</sup> Containing nitrogen . . . . .	3.27
Equal to ammonia . . . . .	3.97

A sample of pure Indian bone-meal, if as dry as this sample was, would have contained probably 50 per cent. of phosphate of lime, and about 4½ per cent. of ammonia.

#### WATERS.

A larger number of waters have been sent to me for examination than usual. Out of these, there is one case to which it is desirable to refer, as illustrating the caution which it is necessary to observe when sending up samples of water for analysis. Too often an old spirit jar, provided with an old and generally badly-fitting cork, is used for holding the water. A scum has frequently collected round the inside of the jar, and is not easily removed, but it may nevertheless taint the water, though the latter be good in itself. It is for this reason that I infinitely prefer samples of water to be sent in glass-stoppered Winchester bottles, holding half a gallon each. It is then apparent whether a water be clear or cloudy, or whether any sediment or scum be left on the bottle. The analyst must simply report upon what he finds, and it is not everyone who can discriminate (indeed, often it is quite impossible to do so) between a water naturally pure but fouled by being put in a dirty jar, and one which is naturally impure. A member of the Society sent me a sample of water in a stone jar, and on analysis it showed :—

	Grains per gallon
Oxidisable organic matter . . . . .	.54
Free ammonia . . . . .	.0105
Albuminoid ammonia . . . . .	.006

figures which, standing by themselves, would lead a chemist to suspect impurity of the water supply. There were, however, other

points in the analysis which I could not reconcile satisfactorily with this conclusion. I suggested, therefore, that perhaps the jar had not been properly cleaned, and that it would be better to send a fresh sample. This was done, and the water was again analysed, giving then the following results :—

	Grains per gallon
Oxidisable organic matter . . . . .	.15
Free ammonia . . . . .	.003
Albuminoid ammonia . . . . .	.0015

These figures were very different from those first given, and were quite consistent with the other parts of the analysis, as also with the composition of a water from a pure drinking supply.

It has been my practice to conclude my annual report by giving a few analyses of miscellaneous materials which have come under my notice during the year. The following are some examples of this class.

*Soot.*—A sample procured with considerable care, so as to obtain nothing but the fine soot itself, as deposited in a chimney, gave the following high analysis :—

Water . . . . .	4.70
<sup>1</sup> Ammoniacal salts and organic matter . . . . .	72.61
Oxide of iron, lime, &c. . . . .	13.35
Siliceous matter . . . . .	9.34
	100.00
<sup>1</sup> Containing nitrogen . . . . .	6.04
Equal to ammonia . . . . .	7.33

*Deposit from Wool-cleaning.*—In the water used for wool-cleaning a considerable amount of deposit forms ; this, after drying, can be used as a manure. Analysis of a sample gave the following :—

Water . . . . .	4.79
<sup>1</sup> Organic matter . . . . .	41.03
Phosphate of lime . . . . .	.31
Oxide of iron, &c. . . . .	4.47
Sand . . . . .	49.40
	100.00
<sup>1</sup> Containing nitrogen . . . . .	2.64
Equal to ammonia . . . . .	3.21

More than half of this is sand and earthy matter, but still there is over 3 per cent. of ammonia, and the material was in a nice dry state. When broken up it would do well for mixing with artificial

manures for the purpose of diluting them, or for spreading on grass-land. Of course it would not bear the cost of carriage to any distance.

*Cutlers' Dust.*—A sample of this, obtained from Rotherham, gave on analysis :—

Moisture . . . . .	5.94
<sup>1</sup> Organic matter . . . . .	34.46
Phosphate of lime . . . . .	10.64
Carbonate of lime . . . . .	4.86
Metallic iron . . . . .	22.95
Sand . . . . .	21.15
	100.00
<sup>1</sup> Containing nitrogen . . . . .	2.46
Equal to ammonia . . . . .	2.98

3*l.* 15*s.* a ton, delivered, was the price asked for this, one which is decidedly above its value.

*Sulphate of Copper.*—In connection with the experiments conducted by the Society on the efficacy of Sulphate of Copper as a preventive of Potato Disease, Mr. E. Riley of Hessle, Hull, brought to my notice that, during his tour, he had come across an instance of a farmer who was trying the remedy, but the sulphate of copper he was using, instead of giving a bright blue solution, formed a greenish coloured one. Mr. Riley therefore sent me up a sample of the supposed sulphate of copper, and on examination I found it to contain a very considerable admixture of the much cheaper salt sulphate of iron (green vitriol). The two crystalline salts had been ground up together, so as to allow the blue colour of the copper salt to predominate. As there is a likelihood of the use of sulphate of copper extending, it is well to put farmers on their guard against buying it when adulterated with sulphate of iron. If purchase of ground-up powders be avoided the difficulty will not be experienced, inasmuch as the large blue crystals of sulphate of copper are easily distinguishable, when separate, from the green ones of sulphate of iron, whereas, if ground together, the admixture may not be apparent to the eye.

During the year I have contributed the following papers to the Journal of the Society :—

- No. V. Indian Agriculture in its Physical Aspects.
- „ Annual Report of the Consulting Chemist for 1889 and 1890.
- No. VI. Field Experiments at Woburn in 1889 and 1890.
- „ Experiments conducted by Local Agricultural Societies in 1889 and 1890.
- No. VII. The Trials of Cream Separators at Doncaster.
- „ The Comparative Feeding Values of Decorticated and Undecorticated Cotton-cake.
- No. VIII. Annual Report of the Consulting Chemist for 1891.
- „ The Sampling of Manures and Feeding-stuffs.

I append the list of analyses made in the Laboratory during the past year.

*List of Analyses made for Members of the Society, from December 1, 1890, to November 30, 1891.*

Linseed-cakes . . . . .	337
Uncorticated cotton-cakes . . . . .	75
Decorticated cotton-cakes . . . . .	48
Compound feeding-cakes and meals . . . . .	54
Rice-meals . . . . .	4
Cereals . . . . .	8
Dried grains . . . . .	4
Silage and hay . . . . .	5
Butter, milk, and cream . . . . .	11
Waters . . . . .	164
Superphosphates . . . . .	153
Dissolved bones and compound artificial manures . . . . .	133
Bones and bone-meals . . . . .	90
Peruvian guano . . . . .	14
Fish guano . . . . .	22
Shoddy . . . . .	25
Soot . . . . .	8
Basic slag . . . . .	31
Sulphate of ammonia . . . . .	12
Nitrate of soda . . . . .	58
Potash salts . . . . .	10
Lime . . . . .	22
Refuse materials . . . . .	45
Soils . . . . .	13
Miscellaneous . . . . .	12
	<hr/>
Analyses in connection with the Annual Country Meeting . . . . .	40
Analyses in connection with the Woburn experiments and those of Local Agricultural Societies . . . . .	63
	<hr/>
Total . . . . .	1,358
	<hr/>
	1,461

J. AUGUSTUS VOELCKER.

## ANNUAL REPORT FOR 1891 OF THE CONSULTING BOTANIST.

DURING the past year 250 applications have been received from members of the Society. These refer principally to seeds for laying down pastures, but a larger proportion of inquiries have been made than in previous years in regard to injuries to stock from poisonous or dangerous plants, and injuries to crops from the attacks of parasites.

### SEEDS FOR PASTURE.

The quality of the grass-seeds, both as regards purity and germination, was on the whole very satisfactory during the past year. The grasses most largely used appear to be timothy and cocksfoot. The only impurity in timothy met with was some seeds of florin: its germination was very high; in no case did it grow less than 90 per cent., while the average was 96 per cent. In the cocksfoot the only seeds that were frequently found were those of Yorkshire fog, but they never amounted to more than 3 per cent. The average germination amounted to 84 per cent. This was reduced by samples which contained a considerable quantity of unripe seeds, with a consequently low rate of germination. Nearly half of the samples gave a germination of over 90 per cent.

The large fescues were free from weeds and from the seeds of other grasses. The germination was most satisfactory, that of meadow fescue giving an average of 94 per cent., and of tall fescue 88 per cent., after excluding an unsatisfactory sample composed to a large extent of nearly empty glumes, and growing only 35 per cent.

The small fescues contained more impurities, the most prominent being the small awned seeds of hassock-grass, one sample containing as much as 8 per cent. of this undesirable grass. Hard fescue gave a germination of over 78 per cent., while sheep's fescue was lower, giving no more than 74 per cent.

Meadow foxtail was generally free from hassock-grass. One sample contained 6 per cent. of this seed. The germination averaged 73½ per cent., when one sample is excluded, which was composed mostly of empty chaff, reminding one of the samples frequently met with some years ago, and grew only 35 per cent.

The meadow grasses were free from weeds and the germination was satisfactory. The smooth-stalked meadow grass had an average growth of 87 per cent., rough-stalked meadow grass of 79 per cent., and wood meadow grass of 73 per cent.

Dogstail is deservedly going out of use. For pastures it is a very poor grass. The seeds I examined were pure, and the samples had an average germination of 94 per cent.

Tall oat grass is being more used. The seeds are pure, but the germination has not risen above 62 per cent.

A considerable proportion of the rye grasses contained weeds, chiefly ox-eye daisy, buttercup, and sorrel. The average germination of perennial rye grass amounted to  $87\frac{1}{2}$  per cent., and of the Italian to  $90\frac{1}{2}$  per cent.

Some more decided effort should be made by the trade to supply clovers more free from weeds than the samples one generally meets with. The great change that has been effected in the cleaning of grass seeds might with advantage be extended to those of clovers. They are at present the principal vehicles for introducing weeds into our fields. In the white clover, 73 per cent. of the samples examined contained the seeds of weeds: in one case amounting to no less than 15 per cent. of the clover seeds. In red clover (including the cow-grass of commerce) and alsike, 68 per cent. contained weeds. In the alsike several samples had 10 per cent. or more of weeds. The worst weed in clover is, of course, the dodder. Ten per cent. of the samples of red clover contained dodder, while in alsike no less than 32 per cent. had dodder seeds, and in one sample there was as much as  $4\frac{1}{2}$  per cent. of them. That clovers can be supplied clear and free from dodder is evident from the fact that 32 per cent. of red clover and alsike and 27 per cent. of white clover were quite free from weeds. The average germinations were fairly good: the white clover gave  $88\frac{1}{2}$  per cent., red clover 92 per cent., and alsike  $90\frac{1}{4}$  per cent. The samples of trefoil were more free from weeds. The average germination of this seed was  $90\frac{1}{2}$  per cent., while lucerne was somewhat lower, being 85 per cent.

The samples of yarrow continue satisfactory, both in purity and germination. There have been no weeds in the samples examined, and the seeds have grown nearly 80 per cent.

It should be remembered that some seeds soon lose their power of germination, and it is consequently very undesirable to keep seeds. In one parcel examined, which had been kept for two years, scarcely a single seed of meadow foxtail in the mixture germinated.

#### TURNIP SEED.

Cases of mixed crops produced from seeds purchased as pure turnip seed have been brought under my notice. The seeds of turnip so closely resemble those of cabbage and some allied cruciferous plants that it is most difficult for the purchaser to distinguish such impurities. But the appearance of a large proportion of kale or cabbage in a crop of turnips can be due only to the use of mixed seeds. It is necessary that the purchaser should be precise in designating the seeds that he orders, otherwise he may not be able, when the impurities appear in his crop, to recover the loss he has sustained from the merchant who did not supply what was ordered.

ERGOT.

Inquiries have been made as to the cause of abortions in cows, mares, and sheep, supposed to be due to ergot. The Rev. C. Wolley Dod, of Edgehill, Malpas, Cheshire, writes, "The greatest losses in this neighbourhood generally take place when the cows are not turned out, from November to February. I used to suppose the ergot was in the hay, and that particular parts of the stack, or particular meadows, contained it in greater quantity. But observation has led me to conclude that there is hardly any ergot at the time the hay is cut. It appears here in August, and is most prevalent in September. I think nine-tenths of the ergot here grows on *Lolium perenne*, which is not a prevalent grass in the hay meadows." It is important to notice that the cases of supposed injury from ergot took place in the winter when the stock were being fed in the house, and chiefly on hay. Mr. Dod's observation agrees with what is known of the life of the parasitic fungus. Hay should be cut, and as a rule is cut, when the principal grasses are in full flower, and when the ergot, if present, would be extremely rare; but no meadow has all its grasses in flower at the same time, so it is to be expected that the earlier grasses which are in fruit at the time of cutting may have been attacked by the ergot. If these grasses formed a considerable proportion of the hay, ergot on them might be the cause of abortion; but this does not appear to be the case.

The hay used for food for cows on a farm near Burnham-on-Crouch, Essex, was found to contain in a considerable parcel only one fragment of ergot, showing the presence of the fungus in the hay, but in such small quantity that the abortion could not be attributed to this fungus.

Near Tunbridge Wells, Kent, the cows on a certain farm are not liable to abortion, but on the same farm several brood mares during 1890 and 1891 slipped their young. My correspondent supposes that the freedom from attack among the cows is due to their being given old land hay, in which there is no rye grass. His mares were isolated from one another, and the boxes and stables thoroughly disinfected, so that it was very improbable that the abortion was due to infection or contagion. It was supposed to be due to ergot in the hay, but that this was not the case was proved by a careful examination of portions both of the rye grass and clover hay, and of the meadow hay, which showed that they contained no ergot. Moreover, a parcel of the seeds and fragments that had fallen from the rye grass in the hayloft was also free from ergot.

Some sheep at Adisham, near Dover, slipped their lambs in March this year. A sample of the hay which formed part of their food was examined, and it was found to be free from ergot and from any injurious weeds.

The examination of the grasses in fruit in pastures during autumn shows often a large amount of ergot. This is especially the case in wet seasons, and in all seasons the ergot is more likely to be found on the water grasses, or on those growing in low damp ground.

But the action of ergot on the involuntary muscles of the uterus in the advanced stages of pregnancy is speedy. The influence of the ergot on the involuntary muscles of the arteries, which causes gangrene, may be cumulative, but it certainly is not so in abortion. If ergot be the cause, it must be due to a sufficient quantity being taken with the food a short time before the abortion takes place. And it is evident this could not have been the case in the instances that have been investigated by me during the past year.

#### WEEDS.

Inquiries have been made as to getting rid of Yorkshire fog, which abounds in so many pastures. This is a very difficult matter. Yorkshire fog is a perennial grass, and consequently retains its hold on the soil; being usually rejected by stock it fruits freely, and the seeds, protected as they are by a hard covering, are preserved from injury, and when attached to the chaff are easily spread by the wind. The result is that, where it exists in a pasture, it not only maintains its place, but increases, so that the bulk of some pasture and hay-fields consist of this grass. On rich soils, and where it has been well manured, it is eaten; otherwise it is rejected, unless when hunger and the want of other food compels the stock to eat it.

Several applications have been made as to the presence of garlic in crops. The different species of *Allium* have a foetid and pungent odour; when eaten by stock this odour is communicated to milk, cream, and cheese, and even the eggs of fowls which have picked up the seeds in the fields are affected by it. The garlic appears in pastures in the first part of the year, sometimes in great abundance. After midsummer the weed has completed its year's life, and withers up, so that the pasture may be eaten without injury. But when hay is cut early from a meadow containing garlic, the result is the same as when the stock eat it in the pasture. These plants are perennial; the small bulbs, filled with a store of food which enables the plant to grow vigorously in the spring, present the great difficulty in getting rid of it. Any fragment of the bulb left in the ground when an attempt is made to get rid of them by digging them up may produce a new plant. I have suggested hand pulling as soon as the leaves appear, and continuing this throughout the growing season. This would exhaust the bulb, and though some of the plants would appear the following year, they would be weaker, and being again pulled this would probably destroy the garlic altogether.

Some fields in the neighbourhood of Bruton, Somerset, planted in wheat, showed a luxuriant crop of garlic, the seeds of which, being collected with the wheat crop, imparted their taste and odour to the flower, and rendered the wheat unsaleable.

#### INJURIES BY PARASITIC FUNGI.

A field of clover in Northamptonshire, which looked well in the end of March, began to die off from an attack of *Peronospora trifolii*,



a minute fungus very close to that causing the potato disease. Nothing can save the crop thus attacked, as the fungus lives on the stem just above the root, and so destroys it that the communication between the roots and the plant is interrupted. The ceasing to grow clover on such a field for some years is desirable as the only way to get rid of the spores of the fungus. A field of barley near Norwich was attacked by the fungus which I described many years ago as "straw blight." My correspondent informs me that the seed was drilled in March, the plant came nicely, and it looked a splendid crop until the end of April. Then the field began to look patchy, and in August ten acres in the field of fourteen produced a very poor crop of starved and imperfectly filled ears. The injury here is very much the same as that just noticed in the clover. The fine threads of the fungus take possession of the lower joints of the stalk, destroy the tissues, and stop the living connection between the roots and the stem. The fructification of the attacking fungus has not yet been observed, and my attempts this year to cultivate the diseased straw so as to obtain the fruit were unsuccessful.

A similar injury was caused to a field of oats near Limavady, Ireland. The plants sprang very well, and grew with apparent strength and vigour until the beginning of July, when they began to look sickly and then die off. This was caused by the microscopic nematoid or eel worm (*Tylenchus destructor*) attacking the base of the stem and eating up the tissues, and so stopping the connection between the stem and the roots.

WM. CARRUTHERS.

---

## ANNUAL REPORT FOR 1891 OF THE HONORARY CONSULTING ENTOMOLOGIST.

DURING the last twelve months applications regarding identification of injurious insects, and methods of preventing their ravages, and inquiries on points bearing on the subject as a matter of Agricultural Entomology, have continued without any break, as have also my own careful endeavours to attend to all applications.

The number of letters received has been approximately between twelve and thirteen hundred. These (besides inquiries and consultation regarding nature, &c., of crop, fruit, and timber insect pests) included also inquiries how to obtain, and how best to give, information on crop insect considerations, especially in connection with agricultural instruction under direction of the County Councils; between two and three hundred letters regarding the use of Paris green; and also communications regarding warble prevention; likewise some amount of correspondence regarding attacks to Colonial

produce, as to Tea, Rice, Cocoanuts, &c., and a most extraordinary and injurious outburst of flies, which proved on skilled identification to be of the same kind as our English "Blue-bottles," in the Falkland Islands. I have also been in correspondence with the leading Official Entomologists in Canada and the United States and elsewhere, as occasion required.

With regard to the crop insect attacks of the past season, I should say that the year has been remarkable for almost all the commonly known infestations being more or less present—that is to say, that taking such crops as Turnip, Cabbage, Mangel, Mustard, and to some extent Corn, most of the common attacks were represented, and many kinds of fruit insects were also present. Besides applications regarding these infestations, there were many incidental inquiries respecting less well known and less injurious insects. The experience of the year has in no way justified the hope expressed by some early in the season, that "the cold would have killed the grubs."

The great attack of the year has been that of the DIAMONDBACK MOTH (*Plutella cruciferarum* of Zeller), which I have already reported on in the Journal of the Society (Vol. II. Part III. pp. 596-630) up to about the middle of August, when the worst was over. Since then (that is, between the 6th and 25th of October) I received reports from about fourteen different observers as to the amount of recovery of their crops after the infestation.

From near Doncaster to so far north as Berwick-on-Tweed most of the observers noted the state by such expressions as "suffered little," "capital crop," "worked out satisfactorily," or the more doubtful commendation of "leafage good" or "very vigorous leafage;" but on crossing the Border a decided loss on bulb growth was noted.

In Berwickshire the farmers inquired of concurred in the view of the turnips looking splendid, but being behind in bulbing, owing to the check; farther north, in Fife, two observers respectively reported, in one instance that the turnips improved after the rains, but in many instances were not bulbing well, and in the other that the early turnips were a fair crop, but the later "were a lot of leaves, but the bulbs small." Farther north still, from near Carnoustie, in Forfarshire, the leafage was reported as "extravagantly luxuriant," but the bulbs half size.

Attack of MANGEL FLY (*Anthomyia betæ*) was more reported than in any year since its first great appearance in 1880, when it was especially hurtful in Westmoreland and Cumberland. In the present year the attacks appeared at various localities in the Midland counties, and in the south and west, but more particularly in Devonshire. The best methods of prevention and remedy have proved, as before noticed, to be good cultivation beforehand and (when the attack is present) the application of stimulating dressings, such as nitrate of soda, to carry the crop through the time whilst the maggot is in the leaf.

Amongst the corn attacks few appear to have been at all generally prevalent. HESSIAN FLY has been very little reported, and, where observed, noted as doing little damage. GOUT FLY was much less reported than is usual, and CORN SAWFLY scarcely at all. CORN APHIDES were rather more than customarily present.

The destructive infestation of the WHEAT BULB MAGGOT (the larva of *Hylemyia coarctata*) was, however, again seriously mischievous, mainly in the eastern counties. This attack (in which the damage is caused by the maggot feeding in the "bulb" of the young wheat plant) has for some years past caused serious loss, and until the past season we have not been able to ascertain in what form it began on the plant. Now, however, by collating last season's information with that previously sent, there appears proof that the attack cannot be caused by the wheat bulb flies laying eggs on the young wheat, and consequently setting on foot maggot attack, but arises by maggot attack from eggs laid in the land during the summer.

Mangel Fly.  
*Anthomyia beta*, Curtis.

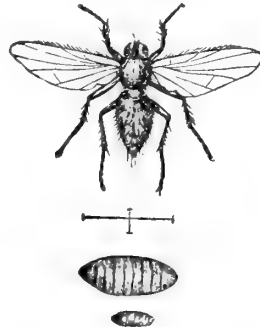

Mangel Fly, magnified; lines showing spread of wings, nat. size; pupa, nat. size and magnified.

Wheat Bulb Fly. *Hylemyia coarctata*, Fallen.



Wheat Bulb Fly (*Hylemyia coarctata*), magnified, and lines showing nat. size; maggots and chrysalids, nat. size and mag.; mouth apparatus, and extremity of tail, with tubercles, mag.; infested plant.

We cannot find, after three years' watch (by an expert) on wild grasses, in an infested district, that there has ever been any presence of a summer brood on grass, nor have we knowledge of its being on

corn ; therefore, as we cannot after such long watch find a summer brood, and the flies of the spring brood come out, and presumably also die, early in the summer, it appears beyond all reasonable possibility that the autumn and winter attack should be started by *fly* attack.

In proof of the attack being from *maggots* in the ground, we find, where a portion or portions of a field have been fallowed or exposed to sun by failure of crop during the summer (in districts liable to infestation), that on these portions the wheat bulb attack (which notably follows fallow) is liable to be bad, while in the other parts of the field which were protected from exposure the wheat is safe. This difference, we find, may be traced even to a plough-line, or precise coincidence of area of maggot attack in strips or patches to where the ground was exposed to sun, and *non-attack* where it was protected. Thus, it appears strongly to point to the attack being in the ground, not coming on the wing, in which case the little flies would distribute themselves more or less generally over the wheat field, or at least not attack quite markedly with almost mathematical precision and there stop. Various other points, which time does not allow of insertion here, confirm this and give the key from fields fallowed in patches to the great attacks. So far as I can judge we have now the clue to getting the mastery of this destructive attack which has long had everything its own way.

If a few experiments could be tried on land considered likely to be infested, by ploughing a small portion with a skim-coulter attached to the plough, so as to turn down the top slice of the land with the contained eggs and maggots, before late wheat was put in, we should see whether the infestation could not be got rid of.

A deal of information has been sent in this year, and I should be happy to give my best attention to any inquiry, for it is a very serious attack.

Amongst other infestations we have now traced the MITE or ACARUS (*Tyroglyphus longior*) sometimes troublesome to hay in the north to being present in the field under the "Cocks," or "Tramps," and the history will probably be completed next season. The STRIG MAGGOT, which has done a good deal of mischief to hops in some places in Kent by destroying the central stem, or "strig," of the hop cones, has proved, from specimens sent to me, to be the larva of a *Cecidomyia*—that is, a little grub nearly allied to the well-known "red maggot" of wheat. These "strig maggots" fall from the hop cones, and bury themselves in the surface of the hop hills. A peculiar and much deformed growth of the heads of tares has also proved from specimens sent me to be caused by a cecidomyioid maggot.

Amongst fruit insects there has been opportunity for studying the life-history of the APPLE SAWFLY, which, when known of, might easily be kept in check, but which probably has been doing a quite unnecessary amount of mischief, from the caterpillars not having been distinguished from those of the codlin moth. Also various kinds of insects seriously injurious in great raspberry and currant grounds have been serviceably brought forward by the Evesham

Fruit-growers' Experimental Committee, with which I am in communication.

It is greatly to be hoped that this Committee may continue its work, as, by the co-operation of the members, attention is at once brought to bear on any previously unidentified attack which may appear to a hurtful extent, and the results of action taken against it be examined and reported on by the Committee.

The results of the experiments at Toddington with regard to the extermination of Winter Moth infestation have been highly satisfactory, and are now promising well for the future; on November 5, Mr. C. D. Wise wrote to me that up to date he had not heard of more than six female moths being found throughout the plantations, grease banding having been commenced a month before.

Paris green, used as a spraying for destruction of orchard caterpillars, may now, I think, be considered as established as a safe and

*Mites (in Hay). Tyroglyphus longior, Gervais.*

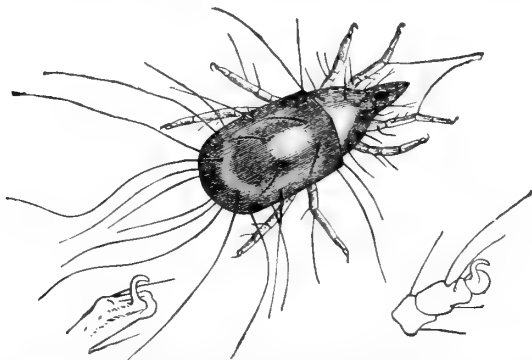

*T. longior* (from fig. by Fumozze and Robin): claw and sucker of *Tyroglyphus*, right-hand side (from Murray's "Aptera"); claw and sucker on left-hand side, figured by author from life: all magnified. Nat. length rather more than half the 25th of an inch.

serviceable remedy, when used according to the directions sent out. But I am careful in the extreme in warning that the spraying should not be applied to fruit or leafage, which can be used for food of man or of farm-stock, within such a space of time as might allow even possibility of bad effects. It may very likely be found to be a safe application for turnip leafage (by-and-by); but at present, and until we have trustworthy detailed reports of experiments as to proportion used, weather at time of spraying, and amount of time elapsing between date of spraying and consumption of the leaves without bad effects, I warn, in all cases where I have opportunity, of the risk of use.

Great advance has been made during the year in knowledge of practically useful insecticides, and in the introduction or home manufacture of spraying machines and other implements for their distribution.

In reply to inquiries sent to me as to methods of Entomological Agricultural instruction, I endeavour to point out that it is *not* simply entomological science that is needed, in the sense of classification and the like, but knowledge of insects, especially of crop insects, which will give capability of distinguishing them in their different stages, and of methods of prevention which throw them under the power not only of special measures, but also of ordinary garden and farm treatment.

The above are only such short notes as may now be offered of some of the year's work, but if desired I would give information on any of the year's subjects in full detail.

ELEANOR A. ORMEROD.

---

## REPORT OF THE JUDGES ON THE MILKING MACHINE EXHIBITED AT DONCASTER.

THE Royal Agricultural Society has made more than one attempt to encourage the invention of an efficient milking machine, by the offer of prizes of substantial amount at its annual Country Meetings. In connection with the Bristol Meeting of 1878, when the Show was held in the centre of a famous dairy district, prizes were given for a great variety of utensils used in dairying (milk-cans, churns, butter workers, cheese tubs, curd knives, curd mills, cheese-turning and churn-cleaning apparatus, milk coolers and the like); and last on the list was the offer of a prize of 50*l.* for "the best milking machine, to be tested during six consecutive months of the spring and summer of 1879." Unfortunately, no competitors appeared for the prize, and the Judges, commenting on this fact, observed:—

The Judges greatly regret that there was no entry in Class xiv. for the best milking machine. He who successfully solves the difficulty will reap a rich reward. The want of such a machine is the one missing link in dairy management. Greater mechanical difficulties have been overcome, and we hope before many years to see the milking machine difficulty practically solved.<sup>1</sup>

In 1882, at Reading, the offer of 50*l.* for the best milking machine was repeated, but with a precisely similar result, for although there was one solitary entry from a Copenhagen firm of a machine which was priced at 3*l.*, it was not exhibited at the Show.

Undeterred by this failure, and perhaps encouraged by the description of a machine of the kind (known as the "Murchland") in the Journal for September 30, 1890 (Vol. I. Part III. page 645), the Council offered two prizes of 20*l.* and 10*l.* for competition

---

<sup>1</sup> Journal, Vol. XV., Second Series, Part I (1879), p. 156.

this year at Doncaster for the best milking machine, without any restrictions as to working for a period after the Show. For these prizes only one competitor, Mr. John Gray, of Stranraer, Wigton, N.B., appeared, and the machine he showed was not the "Murchland," but one invented by Mr. S. Nicholson, a young farmer of Kirkcudbrightshire, and known as "Nicholson and Gray's New Patent Milking and Self-registering Machine."

The machine is an adaptation of the principle of suction by creating a vacuum to draw the milk out of the cow's udder. Its construction is as follows:—An air-pump, driven by hand or power, fixed on a small tank which acts as a vacuum reservoir, is connected with a main of  $\frac{3}{4}$  in. dia. gaspipe, laid as most convenient through the cow-stalls. At the partition between each stall is a branch terminating about 3 feet from the ground, at the end of which is a cock, very simply made with a rubber plug. From this point a rubber tube is attached to a circular tin vessel of about 18 inches diameter and 15 inches deep, answering to the milking-can. This vessel has a closed top with one round opening about 4 in. diameter, closed by a rubber disc, which, when the vacuum is turned on, is securely held in its place by the pressure of the outside air. Through this disc are two small metal tubes, to each of which is attached a short length of rubber tube ending in a cross piece of metal tube. On to each cross is slipped another short length of rubber tube, terminating in the small end of a short piece of cow's horn, at the large end of which is a rubber ring, to form an air-tight joint between the teat at its base and the horn.

To set the machine in operation, the pump is worked until about fifteen inches of vacuum are formed. The horns are adjusted to the teats and the vacuum turned on to the pail by opening the rubber cock, and almost instantaneously the milk begins to flow, as can be seen by a slip of glass in the side of the pail. Two cows are milked at the same time into each pail. The glass in the side of the vessel has a scale of gallons marked upon it, so that the quantity yielded can easily be ascertained. To make sure that the cows are milked clean, all the horns but one are removed and the remaining one applied to each teat in turn.

There is certainly great cleanliness in this method, as no dirt can possibly get into the milk, and for cows with sore teats there is none of the squeezing or irritating pulling which takes place in ordinary milking. As regards cleaning the apparatus, the short lengths of tube through which the milk flows are readily cleaned by a small circular brush fixed on wire, as was carefully noted by us: so that this need not in any way be an obstacle to the use of the machine.

The air-pump when milking one or two cows is easily worked by a strong boy; when four or six are being milked a small engine should be used. A two horse-power engine would work any reasonable number of machines. The attachment of the "milking-can" can be made by any intelligent boy or girl, and the connection with the suction tubes can be applied without danger or difficulty. After

a little practice a boy with three of the milking-cans and connecting tubes and horns could keep four or six cows milking at one time.

The machine was tried during the Show week on two cows hired from a farmer in the neighbourhood of Doncaster, and was the object of much attention from the visitors. One of the cows was a decided kicker, but after a day or two got quite accustomed to the machine. The other was much quieter from the first; neither had ever been tried with a machine before, and neither cow was in full milk. We were well pleased with the apparent capabilities of the system; but with strange cows and in the noise and crowd of a Showyard we felt the trial was neither fair to ourselves nor to the exhibitor, and we therefore asked the Council to give us the opportunity of seeing the machine on farms where it had been at work for some months, to test its efficiency on a number of cows at once, and inquire into its freedom from injury to their udders and milking properties. Meanwhile we recommended the machine for one of the Society's silver medals, as a meritorious new invention of agricultural value.

The desired permission to inspect the working of the machine on the farms where it was regularly in use having been granted by the Council, we made a tour of certain Scotch dairy farms in the early part of October.

On the evening of Oct. 9 we found the machine applied to the standings of thirty cows at the Dunragit Creamery Farm Buildings, and saw the machine attached and applied to the milking of four cows at once. We saw, too, how easily and rapidly the apparatus was cleansed, and how quickly it was laid ready for the next milking, by two of the ordinary "milkers" on the farm. Next morning we saw it applied and worked by Mr. Wallace of Auchenbrain on a number of his own cows in an easy and natural way. We tested them after milking by stripping, and found only the usual quantity which comes after the best milker has done. In the afternoon we drove from Glasgow to Messrs. Stevensons, Dairy Farmers, South Farm, Cathkin, and found the machine in the hands of two brothers, both practical and shrewd business men, wanting chiefly to get their cows milked efficiently in the least time and at the least cost. "They had had a machine at work during the year, had used it upon more than half their cows (90), and had found it very helpful! They had not had any bad effects to note upon udder or upon health or in the ordinary milking capacities of their herd. There were some cows, the hard milkers, they could not use it on with advantage, nor could they upon those that held their milk." We asked to see it at work upon two such cows, and soon saw it was wanting in power to do this. "We have tried this machine," these gentlemen seemed to say, "fully and fairly; it does very well so far, but it does not quite meet all our difficult cases. It is, however, a great help, and we shall stick to it and hope to see it improved." When questioned as to any injury their cows had taken from its use, their answer was emphatically—"None;" and this was the general testimony.



From here we drove to Newton Farm, where we called to see the Murchland milking machine at work. Mr. Speir, the tenant, received us very kindly, and under the direction of Mr. Murchland the cowman applied the machine easily to several cows, one after another, and it worked fairly well. One point of difference it had was that it was worked by the vacuum obtained from a column of water (as described on page 645 of the Journal for 1890). Otherwise the principle was the same, but the details of application were different. As the Murchland machine was not in competition with that shown at Doncaster, we abstain from further comparison.

The chief defect in the Nicholson and Gray machine is the one we noted at Doncaster. The pulsation of the action upon the cows' teats, answering to the partial opening and shutting of the hand in milking, is not powerful enough to keep the milk continuously flowing as the quantity in the udder diminishes. The inventors say they are adding an improvement which will effect this, and if this were done it would bring the machine near perfection.

If a further improvement by which a little additional power to draw the milk quicker could be gained, without bearing harder upon the udder or the system of the cow, this machine would be very complete. As it is, a little practice would bring it into more easy working, and we have not observed any injury done to cows that have been milked by it all the summer, nor do we see how injury could come. We think it is sufficiently developed for the dairy farmer to be advised to use it, and that after becoming familiar with its working, he will not willingly relinquish its use.

An efficient milking machine will supply a great and pressing want in dairy districts, as there is a universal cry of the rapidly increasing difficulty of getting good milkers. Although the Nicholson and Gray machine is not so complete as we could desire, yet we think it fulfils the requirements laid down by the Society when issuing its prize-sheet, and we therefore advise that the prize of 20*l.* be awarded to the exhibitor as an encouragement and a stimulant to make it perfect.<sup>1</sup>

November, 1891.

R. NEVILLE GRENVILLE.  
THOMAS RIGBY.

---

<sup>1</sup> This recommendation was confirmed by the Council at its Meeting held on November 4, 1891.—ED.

## Notes, Communications, and Reviews.

### THE SAMPLING OF MANURES AND FEEDING-STUFFS.

ATTENTION has of late been directed somewhat specially to the prevention of fraud in connection with the purchase of manures and feeding-stuffs. This is largely due to the Government having expressed its intention of shortly introducing in Parliament a Bill on the subject.

It is therefore a suitable opportunity, while urging the necessity of resort to chemical analysis, to point out certain conditions which ought to be observed in order that an analysis may be of full value, and in its results be equally fair to both vendor and purchaser.

The conditions to which I would here refer are briefly these :—

Firstly : *A sample sent for analysis should be fairly representative of the bulk from which it was drawn.*

Secondly : *The sample should reach the analyst in the same condition as at the time it was drawn ; in other words, it should not suffer change during transit.*

Little should be necessary to show that, in justice to the vendor, the foregoing conditions should be observed ; nevertheless, vendors of manures and feeding-stuffs are often not only put to considerable inconvenience and annoyance, but may also suffer in reputation through non-observance of such self-evident directions as the above. Thus, a purchaser who has had, say, mineral superphosphate guaranteed to him to contain 26 per cent. of soluble phosphate, may take a handful out of the top of the first bag he comes to, and, packing this up loosely in paper, may send it to a chemist for analysis ; then, if he finds it turn out to have only 25½ per cent. of soluble phosphate, he will think himself perfectly justified in making a claim on the vendor for the deficiency. So he would be, certainly, if the sample were fairly representative of the bulk, but frequently this is not the case, and deficiencies often result from improper sampling and careless forwarding of samples, rather than from any fault of the vendor. Similarly, a farmer may break a bit off the end of a single cake out of many comprising a delivery, and, if

analysis shows any deficiency of quality, he will complain about it, though a sample fairly drawn from the whole delivery may prove the latter to be, on the whole, quite satisfactory.

While analysis, therefore, proves a useful and necessary check, it should be supplemented by the observance of precautions which make it equally fair to both vendor and purchaser.

It is to aid in arriving at a just conclusion that I append the following general directions as to the taking of samples.

*The sampling of manures.*—Manures are generally sent to the farmer in bags, and if their composition were uniform throughout, and the contents of one bag just like those of another, it would be enough to draw a sample out of a single bag. But this is seldom the case, and it may happen, *e.g.*, with superphosphate, that, though practically of the same quality, one part of the delivery has been manufactured at a different time to another part. It is only fair, therefore, to draw a sample, not from *one* bag only, but from *several*. If a purchase consists of six or any lesser number of bags, each one should be opened and a portion drawn from each bag. If it consist of a much larger number, then, a dozen bags, or certainly not less than six bags, should be taken out from different parts of the delivery and be set aside for the purpose of drawing a sample from them. Having set these aside, the very best way with any ordinary artificial manure, such as superphosphate, dissolved bones, bone-meal, compound manures, nitrate of soda, kainit and other salts (anything, in fact, that is in a fairly powdery and uniform condition, and not bulky, or matted together like shoddy or similar refuse materials), is to provide oneself with a special instrument which we may call a "sampler." This is an iron tool about 2 ft. 6 in. long, very like a cheese sampler, and fitted with a wooden handle. It is made of U-shaped iron, with the end sharpened and the edges rounded, the diameter of the groove being about 1 in. The accompanying cut represents such a sampling tool:—



An instrument like this can be driven down into each of the selected bags from top to bottom, and by tilting the bag, giving the "sampler" a twist round and then withdrawing it, a *section* of the entire contents of the bag can be obtained. This may be repeated once or twice for each bag and other similar sections be taken from the other bags. The different lots withdrawn must then be thoroughly well mixed together. Any lumps should be broken down with a shovel, and if the heap is too much to form a conveniently sized sample for sending for analysis, it should be reduced in amount by repeated division and subdivision. This is best done by turning over the heap and mixing it up carefully though quickly, flattening down any lumps, and then dividing the heap into two halves; one half may be rejected altogether and the remainder again quickly

turned over and mixed thoroughly, divided as before, and so on as may be necessary, until a quantity weighing only about three or four pounds is left. Two well-fitting tins, each capable of holding from  $\frac{1}{2}$  lb. to 1 lb. of the material, should then be filled from the heap thus left. One of these should be wrapped up and sent by post to the analyst, and the other be kept by the farmer for reference. Instead of a tin, a wide-mouthed glass bottle with well-fitting cork may be used, and this be enclosed in a wooden box, and so be sent by post or rail; or, the sample may be wrapped in tinfoil or in oiled silk, and be enclosed in a box or in a stout lined envelope. This latter is a very convenient form for nitrate of soda, sulphate of ammonia, kainit, and similar salts. The tin is, on the whole, the most satisfactory, as it is easy to send  $\frac{1}{2}$  lb. or 1 lb. of the manure in it, whilst if a bottle, or tinfoil, or oiled silk be used it is not easy to send so large a quantity. If a smaller quantity be sent, the final heap must be mixed still more carefully, and the sample be taken from different portions of it. In no case, however, should less than 4 oz. be sent as a sample, and when the material is at all uneven in character, or lumpy, or of a mixed nature, it is not satisfactory unless a 1 lb. sample, or in some cases as much as 2 lb. be sent. The more uneven the manure the larger the sample must be; the finer and more even it is, the smaller may be the quantity to be sent for analysis.

One caution further is necessary. Whilst care must be taken to ensure a fair sample being drawn, care must also be exercised not to let the portion that is being sampled lie about exposed too long. The sampling must be done carefully but also quickly, or the material may dry considerably during the process.

In the absence of a special sampling tool such as that described, the best way is, after selecting several bags as directed, either to turn them out one after the other on a floor, and, taking a few shovelfuls from each, to mix these shovelfuls well together for one sample, or (which is not so good) to drive a spade into each of the selected bags, and, after a little mixing, to draw out from as near the centre as possible a couple of spadefuls from each bag, subsequently mixing these lots together, flattening the lumps down, and dividing and subdividing the heap until only some three or four pounds are left. From this the tins or bottles may be filled as mentioned before, one sample being sent for analysis and the other retained for reference.

There remains the special case of the sampling of bulky materials such as shoddy, wool refuse, &c., which, as a rule, are sold, not in bags but in bulk. In such cases a "sampler" is of little use, and the only way is to take portions from different parts of the bulk, or from the selected bags (if bags there be), and, setting these portions aside, to quickly tear apart the matted wool, hair, &c., and mix the lots together as well as it is possible to do, but losing no time so that the material may not dry unduly in the mixing. The final sample must be taken from this by rapid subdivision and remixing as before, but a considerably larger quantity must

be sent up for analysis than in the case of a material like superphosphate. When taking portions from a manure delivered in bulk, it is essential to draw them, not from one part only, but from different parts, interior as well as exterior, for considerable differences of moisture may be noticeable, and it is only by thus taking from various parts that anything like an average sample can be got. Shoddy, especially, is a material very likely to gain or lose moisture according as the atmosphere is moist or dry, and so, both in selecting and in sending samples for analysis, particular care must be taken to have and to keep them in the same state as the bulk. To send a sample of shoddy simply wrapped in a paper cover, or in a linen bag, as is too often done, is to make an analysis quite worthless, and unfair alike to analyst, purchaser, and vendor. The discrepancies which are sometimes pointed to as occurring between the analyses of different analytical chemists, and which are put down to want of care or skill on their part, are, in a great number of instances, due to samples having undergone change during transit, owing to not having been sent in proper covers.

I might instance a case in which a farmer sent me a sample of shoddy, merely wrapped up in brown paper. It gave on analysis about  $5\frac{1}{2}$  per cent. of ammonia, but had about 28 per cent. of moisture. As the result came below the guarantee given him, the farmer sent to two other analysts other samples which he had taken at the same time and had since left lying about in paper. Their reports showed respectively  $6\frac{3}{4}$  per cent. and 7 per cent. of ammonia. On re-testing, for my own satisfaction, the original sample which had been lying about similarly, I obtained results practically agreeing with the other chemists'; but then I found, too, that the percentage of moisture, instead of being 28, was now only about 11 per cent., the sample having dried to this extent meantime, and my original result having been quite correct for the sample as it then was. There were really no discrepancies of analysis, but only of the condition in which the different samples came to the respective analysts.

As an instance of the injustice that may be done in the sending of a sample that is not representative of the bulk, I may mention a case which recently occurred. It is well known that superphosphate is liable to some extent to "go back," as it is termed, upon keeping, showing less soluble phosphate by 2 or 3 per cent., it may be, than before. A farmer had deliveries sent to him monthly for a period extending over six months, upon a guarantee of a certain percentage of soluble phosphate. He took samples from each delivery as it came in, but kept these lying about until all six deliveries had come in, when he mixed them all together and sent up one sample for analysis. Now this was not fair to the vendors, for the real question was—what was the quality of each delivery *as the contractor delivered it?* not, what would a sample test, some of which had been lying about for six months or more, other of it for five months, and so on?

These examples will show the necessity, in the case of manures, of attention being paid to the two conditions I have laid down—viz. :

the first, that the sample sent be fairly representative of the bulk ; the second, that it suffer no change in transit.

*Feeding-stuffs.*—With these, as with manures, similar precautions must be taken for the obtaining of a representative sample, but the changes that are likely to happen in transit are of but small consequence, as a rule. In their place, however, comes in a necessary caution as to the particular observance of the *condition* of a delivery.

Those who have had experience in analysing feeding cakes know that, even in a single cake, results differing to some extent one from the other may be found, according as the piece which is taken for analysis may happen to have been broken off the end, the middle, or some intermediate part of a cake ; for, owing to the way in which the crushed seed is packed in the oil-presses, it is impossible to get the pressure equally distributed throughout. Some parts of the cake, as everyone is aware, are generally thicker than others. The oil is pressed out from the centre and runs away from the edges of the cake ; finally, the edges are pared off all round. If a single cake be taken, the best way is, either to send up for analysis half the cake or to break a whole cake across the middle, and then off each of the halves to take a strip about four inches wide also right across the cake and from what was before the middle piece of the whole cake. Thus two good-sized pieces, taken across the whole breadth of the cake, will be obtained, and they can be wrapped in paper and sent by post or rail. But even this is not fully satisfactory, for sometimes a delivery of cake may vary ; more especially is this the case with decorticated cotton-cake. Occasionally, too, some cakes of a delivery may be a little mouldy or damaged, but a single cake of this kind may not be fairly representative of the whole. It is quite true that if a delivery of cake be guaranteed to be pure, every cake of the whole lot ought to conform to that description, but when the oil percentage or some other constituent, or the general condition be in question, a fair sample of the whole should be taken. A purchaser should, therefore, first look over the cakes comprising the delivery and note any differences of appearance that may strike him, or see whether all the cakes seem much alike. He should then select samples from each different variety he notices, the number of samples being in proportion to the number of cakes of each kind that make up the bulk. Thus, if about half the delivery consists of darker-coloured cake and half of lighter-coloured cake, an equal number of cakes should be taken as samples to represent each sort. Three or four cakes of each sort should be selected, or, if uniform throughout, say, six cakes from the whole lot ; pieces should be broken out of the middle of each as described before, and then these pieces be passed through a cake-breaker. The broken "nuts" or lumps must next be mixed up thoroughly, and then divided successively, just as was advised in the case of manures, until only about a couple of pounds weight are left. Two tins may now be filled with the cake, one for sending to the analyst, the other to be kept for reference. Or, the pieces may be done up in a bag, or wrapped in stout

wrappers, or put in a wooden box, and then be sent by post or rail.

The sampling of other feeding-stuffs such as meals or grain can best be done by means of the sampling tool described before, or, failing it, by taking shovelfuls from selected bags or from different parts of the bulk, and intimately mixing them just as was advised with manures. Such samples are best sent in tins.

The necessity of observing the *condition* of cakes and other materials used for feeding has been alluded to. Seeing that the health and well-being of cattle are concerned, all materials so used should be in a *fit condition* for giving to stock. Thus, should any part of a delivery be observed to be mouldy, or sour, or stale, or any cake to be full of hard lumps, or to have cotton or hair attaching to it, a note should be made of it at the time, and the analyst's attention be drawn to it. In such cases it is advisable that a good-sized piece, say a quarter or half a cake, of the kind complained of be sent separately to the analyst, and the extent to which it occurs be mentioned to him. With decorticated cotton-cake, for instance, it unfortunately often happens that there are hard, indigestible lumps in it, which are not only not good food, but may be positively dangerous to cattle unless finely ground up. This should be pointed out to the analyst, and separate pieces of the cake should be sent for his inspection.

*The time for taking samples.*—In justice to the vendor it is only fair that samples, both of manures and feeding-stuffs, should be taken as soon after their delivery as possible. In every case the analyst's certificate should be received before a manure is sown or a feeding-stuff is given to stock.

*Procedure in the event of the vendor wishing fresh samples to be drawn.*—Should a purchaser find that the analyst's certificate shows a manure or feeding-stuff not to come up to the guarantee given him, he may inform the vendor of the result and complain accordingly. If then the vendor should demand that a fresh sample be drawn, the purchaser must allow this, and also give the vendor an opportunity of being present, either in person or through a representative whom he may appoint. In that case samples should be taken in the presence of both parties with the same precautions as before described, but it is advisable to draw *three* samples, *each* of which should be duly packed up, labelled and *sealed* by both parties. One of these is to be given to the vendor, who may send it for analysis to whomever he may select, and the other *two* samples should be kept by the purchaser for reference or future analysis if necessary. But there is no occasion whatever at this stage for the *purchaser* to go to any further expense in having the fresh sample analysed on his behalf. This is a matter entirely for the *vendor*.

J. AUGUSTUS VOELCKER.

---

## EXPERIMENTS IN THE PLANTING OF POTATOES.

CERTAIN statements as to the advisability of the late planting of potatoes having appeared in some of the daily papers, and being at direct variance with our personal experience in the cultivation of potatoes on a large scale, it occurred to us to conduct some experiments in order to find what would be the exact result of such an investigation.

With that idea one side of an open field, which had previously been prepared for potatoes, and upon the remainder of which a crop of Imperators was subsequently grown, was set aside last year. The land was excellently adapted for the requirements of the crop, being well drained and of a uniform description of light loam, resting on a gravel subsoil. An even dressing of about 15 tons to the acre of good farmyard dung had been put on and ploughed in during the autumn, and the land remained untouched through winter. In the early spring the field received a thorough working, and was brought down to a deep tilth. Drill-marks two feet apart were made right through the land which had to be subsequently planted, and plots of one pole each were carefully marked off.

The fourteen varieties of seed potatoes selected were of the ordinary seed size and had been grown on the farm in the previous year; they included those most favoured by growers and salesmen as well as others not so well known. The Thorburn is an American variety hardly distinguishable from the Beauty of Hebron. The Duke of Albany is of a type to which the Puritan and White Beauty belong. The Village Blacksmith, though now recognised as of no value as a field potato, created a sensation some three or four years ago by its peculiarly dark and netted skin. Daniels' Advance, The Daniels, and Empire State have all done well with us, the two latter being of special quality. Future Fame, Stourbridge Glory, and The Bruce are varieties very similar to the well-known Magnum Bonum.

After the first planting, the seed was turned over every other week and the sprouts were destroyed in order not only to prevent them from heating and exhausting their vigour, but also to ensure that the different plantings should start their growth on equal terms. Otherwise, had some been planted with unbroken sprouts, it is quite possible they might have been above ground as soon as those planted a month earlier. Though the seed, generally, of the earlier varieties, is often sprouted and greened for forcing under garden cultivation, it is practically impossible, owing to the want of space and care required in handling, to effect this on a large scale in the field.

Though last year was generally regarded as a disease-year throughout the country, the weather suited the potato crops in the South Midlands, and there was no more than an average amount



of disease in this district (Bedfordshire), so that good crops were the rule rather than the exception. The rainfall, though spread out in many showers during June and July, was below the average, and the weather was exceptionally fine after July 20.

The first planting was done on March 31, two poles of each variety being spaded in. After an interval of a month another planting took place, a similar quantity of each of the fourteen varieties being again spaded in. All that was done to the land, in addition to what had been done previous to the first planting, was to run the horse-hoe up the drill-marks. This was only fair, as otherwise the land would have become somewhat set, and the potatoes would not have gone in so well at the later as at the earlier plantings; for this reason the horse-hoe was also used before each of the other plantings. After another month—namely, on May 31—another planting was made of all the varieties, but this time and subsequently only one pole of each lot was planted. A fortnight later twelve of the fourteen varieties were planted; and still another fortnight later—namely, on June 28—the last planting was done, and ten out of the fourteen varieties were set. It will be shown subsequently that the plantings were carried late enough for the purposes of the experiment. The potatoes were horse-hoed, hand-hoed, and moulded up in the usual manner, as soon as the crop was sufficiently forward.

The accompanying table shows in a more concise form the varieties selected, and some other particulars, including the final results.

It will be seen that, in accordance with the usual farm practice, the earlies were planted at 24 in. from row to row by 18 in. from set to set, that being about the usual distance when they are not required for digging green; whilst the mid-earlies and main croppers were given a larger space in which to develop—namely, 24 in. between the rows and 21 in. between the sets. The potatoes were regarded as ripened when the stems had entirely died down and no sap remained. As it is practically impossible to fix this to a day or two on some scores of sets, the date put down was that of the next Saturday after the first day when no life could be perceived in any of the stems on the plot. It will be noticed that though the plantings occupied a period from first to last of 12 weeks 5 days, the greatest difference between the time of ripening of the first planting and that of the last planting of any one variety was only six weeks, and this occurred in the first earlies alone. Of the mid-earlies only one plot (White Elephant) made a difference of as much as five weeks, and the longest interval on the main varieties was but four weeks, and that on one variety (The Bruce) alone.

It seems only reasonable to expect the best results from those plantings that had the longest time to develop in the ground, and this is almost invariably the case; for we find that, of the 14 plantings made on March 31, 13 yielded more than those planted a month later, whilst the fourteenth (Myatt's Ashleaf) produced an equal bulk. Of the same number planted on April 30, 13

Potato Experiments under Field Culture (in Bedfordshire), 1890.

Variety	When planted	Quantity	Distance apart	Ripened	Weight of crop	Rate per acre	Difference between first and subsequent plantings	
							Weight	Value at 50s. per ton
Myatt's Ashleaf	March 31	2	24 x 18	Aug. 16	140	5 0 0	—	—
	April 30	2	"	" 30	140	5 0 0	—	—
	May 31	1	"	Sept. 6	42	3 1 1	+1 18 2	+ 4 16 6
	June 14	1	"	" 20	26	1 17 0	+3 2 3	+ 7 17 1
Beauty of Hebron	" 28	1	"	" 27	7	0 10 0	+4 10 0	+11 5 0
	March 31	2	"	Aug. 16	170	6 1 1	—	—
	April 30	2	"	" 30	154	5 10 0	+0 11 1	+ 1 8 6
	May 31	1	"	Sept. 6	56	4 0 0	+2 1 1	+ 5 3 6
Duke of Albany	June 14	1	"	" 20	28	2 0 0	+4 1 1	+10 3 6
	" 28	1	"	" 27	24	1 14 1	+4 7 0	+10 17 10
	March 31	2	"	Aug. 16	150	5 7 0	—	—
	April 30	2	"	" 30	112	4 0 0	+1 7 0	+ 3 7 10
The Thorburn	May 31	1	"	Sept. 6	42	3 1 1	+2 5 2	+ 5 14 3
	June 14	1	"	" 20	25	1 15 2	+3 11 1	+ 8 18 6
	March 31	2	"	Aug. 16	196	7 0 0	—	—
	April 30	2	"	" 30	168	6 0 0	+1 0 0	+ 2 10 0
Village Blacksmith	May 31	1	"	Sept. 6	45	3 4 1	+3 15 2	+ 9 9 3
	June 14	1	"	" 20	2	2 3 12	+4 17 0	+12 3 10
	" 28	1	"	" 27	26	1 17 0	+5 2 3	+12 17 1
	March 31	2	24 x 21	Aug. 23	90	3 4 1	—	—
Daniels' Advance	April 30	1	"	" 30	64	2 5 2	+0 18 2	+ 2 6 5
	May 31	2	"	Sept. 6	14	1 0 0	+2 4 1	+ 5 10 8
	March 31	2	"	Aug. 30	175	6 5 0	+0 10 2	+ 1 6 9
	April 30	2	"	Sept. 6	160, including 6 lb. diseased	5 14 1	+2 7 3	+ 5 19 7
Daniels' Advance	May 31	1	"	" 14	64	3 17 0	+3 2 0	+ 7 16 4
	June 14	1	"	" 20	44	3 2 3	+3 2 0	+ 7 16 4
	" 28	1	"	" 27	14	1 0 0	+5 5 0	+13 3 6

First Earlies

Second Earlies	Main Croppers	Variety	Date	No. of plants	6	198, including 14 lb. diseased	183, including 8 lb. diseased	7	1	1	20	+0 10 2 24			+1 6 9			
												6	10	2	24	1	6	9
Empire State		March 31	April 30	2	14			6	10	2	24	+0	10	2	24	+1	6	9
		May 31	June 14	1	20			2	17	0	16	+4	4	1	4	+10	10	8
		June 14	" 28	1	27			2	11	1	20	+4	10	0	0	+11	5	0
		" 28	Oct. 4	1	4			1	0	0	0	+6	1	1	20	+15	3	6
The Daniels		March 31	April 30	2	14	163		5	16	1	20	+0	16	1	20	+2	1	0
		May 31	June 14	1	27	45		3	4	1	4	+2	12	0	16	+6	10	4
		June 14	Oct. 4	1	4	28		2	0	0	0	+3	16	1	20	+9	11	0
		" 28	Sept. 21	2	21	196		7	0	0	0	+1	0	0	0	+2	10	0
White Elephant		March 31	April 30	2	18	168		6	14	1	4	+0	5	2	24	+0	14	3
		May 31	June 14	1	25	56		4	0	0	0	+3	0	0	0	+7	10	0
		June 14	" 28	1	25	42		3	1	1	20	+3	18	2	8	+9	16	5
		" 28	Sept. 27	2	27	196		7	0	0	0	+1	5	2	24	+3	4	3
Future Fame		March 31	April 30	2	18	160		5	14	1	4	+2	0	0	0	+5	0	0
		May 31	June 14	1	11	70		2	17	0	16	+4	2	3	12	+10	7	1
		June 14	" 28	1	18	40		1	0	0	0	+6	0	0	0	+15	0	0
		" 28	Oct. 4	1	18	14		7	10	0	0	+1	1	1	20	+2	13	6
Stourbridge Glory		March 31	April 30	2	18	180		6	8	2	8	+1	12	3	12	+4	2	1
		May 31	June 14	1	18	82		5	17	0	16	+1	12	3	12	+4	2	1
		June 14	" 28	1	4	210		7	10	0	0	+1	1	1	20	+2	13	6
		" 28	Nov. 2	1	18	70		6	5	0	0	+2	10	0	0	+6	5	0
The Bruce		March 31	April 30	2	4	210		3	17	0	16	+3	12	3	12	+9	2	1
		May 31	June 14	1	18	54		1	2	3	12	+6	7	0	16	+15	17	10
		June 14	Oct. 25	1	25	16		8	0	0	0	+2	0	0	0	+5	0	0
		" 28	Sept. 27	2	27	224		6	0	0	0	+3	2	3	12	+7	17	1
Magnum Bonum		March 31	April 30	2	18	168		4	17	0	16	+4	5	2	24	+10	14	3
		May 31	June 14	1	11	68		3	14	1	4	+4	5	2	24	+10	14	3
		June 14	" 28	1	18	52		0	17	0	16	+7	2	3	12	+17	17	1
		" 28	Oct. 4	1	18	12		8	11	3	24	+1	8	24	+2	14	10	
Imperator		March 31	April 30	2	11	242		7	10	0	0	+1	9	0	12	+3	12	9
		May 31	June 14	1	18	100		7	2	2	12	+1	9	0	12	+3	12	9
		June 14	" 28	1	25	94		6	14	1	4	+1	17	2	20	+4	14	2
		" 28	Oct. 25	1	25	14		1	0	0	0	+7	11	3	24	+18	19	10

again were in excess of those planted on May 31, and one (White Elephant) less. Of the 12 varieties planted on May 31 and June 14, the whole 12 planted on the earlier date yielded more than those planted later, and the whole of the 10 varieties planted respectively on June 14 and June 28 yielded more on the first than on the second planting. So, in comparing these fifty instances of an earlier with the next succeeding planting, we find that no less than 48 yielded heavier crops, one an equally heavy crop, and only one a less crop—the weight including both seed and ware.<sup>1</sup>

That the date of the last planting, June 28, was backward enough was proved by the very poor result obtained, the average weight for the whole lot being very little over 26 cwt. per acre, or not twice the weight of the seed originally planted. In some cases, notably those of The Bruce, Magnum Bonum, and Emperor, they never grew with sufficient vigour to prevent their ripening before those planted a fortnight earlier. We find that the average weight per acre of those planted on March 31 was about 19 cwt. in excess of those planted a month later,  $46\frac{1}{2}$  cwt. above those planted on May 31,  $69\frac{1}{2}$  cwt. more than those planted on June 14, and no less than 105 cwt. in excess of those planted last of all. Putting their average value, one season with another, at the somewhat low figure of 50s. per ton, the first planted exceeded in value the second by 2*l.* 7*s.* 6*d.*, the third by 5*l.* 16*s.* 3*d.*, and the fourth by 13*l.* 2*s.* 6*d.* per acre.

It is often more or less impracticable to commence planting largely before the latter end of March, but these results point emphatically to the necessity of getting the potatoes (particularly the earlier varieties) in by the end of April, for though the falling-off of 19 cwt. per acre is considerable, yet up to that time there is still a prospect of tolerably good yields; but the further fall to  $46\frac{1}{2}$  cwt. of those planted on May 31 puts out of the question all idea of a profit from those planted so late in the season as the last week or two in May, the average of all varieties having fallen to about 84 cwt. per acre, and the later varieties, under these circumstances, doing very much better than the others. But it was from the subsequent plantings that by far the greater proportionate drop took place, the yield of those planted on June 14 falling to 61 cwt. and, as before stated, to 26 cwt. from the last planting.

The four first earlies planted on May 31 averaged rather less than 67 cwt. per acre; the four second earlies—excluding those light croppers the Village Blacksmith—averaged rather over 83 cwt. per acre; and the five main croppers averaged slightly in excess of 111 cwt. As there is no prospect of earlies, or even of second earlies, planted so late, maturing sufficiently early to catch any special price either when fully matured or when dug green, these results would show the necessity of planting a main-crop variety when it is imperative to plant at all so late in the season, as under hardly

<sup>1</sup> "Ware" is the name used among growers, and in the London markets, to denote all saleable tubers larger in size than seed potatoes.—ED.

any conceivable circumstance can a crop of 67 cwt. be expected to pay, whereas 111 cwt. per acre, the yield of the late varieties, should not be a losing crop.

Again, taking the plantings made on June 14, the average yield of the first earlies had fallen to a little under 39 cwt., the second earlies to 59 cwt., and the late varieties to 85 cwt. None of these average results can pay ; but one variety, the Emperor, gave the extraordinary yield of 134 cwt. per acre—more than  $2\frac{1}{2}$  tons in excess of any other variety, and which, had it not been for the good results we have repeatedly obtained with this variety from late plantings (for instance, last year we planted twenty acres of them after May 20, which averaged 7 tons per acre all round, and in some places ran to more than 8 tons), we could hardly have believed to have been possible. The poor results obtained from every variety of those planted on June 28 show planting at that time, under any and all circumstances, to be totally out of the question.

Of those that matured earliest, the two very similar varieties, The Thorburn and Beauty of Hebron, fully ripened by August 16, gave the best results, their respective yields of 7 tons and 6 tons 1 cwt. being considerably better than those of Myatt's Ashleaf and The Duke of Albany. The White Elephant and Empire State did best in the order named of the second earlies, as there was disease to the extent of one ton per acre in the latter, though it had an advantage in ripening a fortnight earlier. The Emperor did by far the best of the late varieties, but there is one important precaution to be observed by growers of this variety, and that is to mould it up deeply and thoroughly, as, owing to its late habit of growth, it runs a considerable risk of being caught by an early frost. We call to mind a field of thirty acres we grew in 1887 which was caught by a frost on October 25. Fortunately for us, we had sold it during the previous week at 20*l.* 10*s.* per acre, to be lifted by the buyer ; but the frost did so much harm to the tubers that considerably more than half the bulk subsequently rotted in the pits, while the effect of the chill on the remainder was to spoil their cooking properties and reduce their price from 70*s.* to 40*s.* per ton. Of the other varieties the Magnum Bonum with its yield of 8 tons to the acre did best, though on the second planting it was beaten by both The Bruce and Stourbridge Glory.

The foregoing results, although detailed for one season only, are thoroughly in accord with our experience as growers, for many years, of more than one hundred acres annually. We may conclude, therefore, with the following advice to growers : Plant the early varieties of potatoes in March, or as early as possible in April. Finish planting all varieties in April ; but, if it is necessary to plant in May, by all means employ a late variety. Of late varieties choose Emperor if possible, and have them well moulded up.

GEORGE MALDEN.

---

FARMING WITHOUT LIVE-STOCK.<sup>1</sup>

It is hardly necessary to go back far into the history of agriculture in order to encounter the belief, formerly undisputed, that the use of dung is an indispensable condition in the maintenance of the fertility of the soil. Farmyard manure was regarded as the source of all fertility, because it was held to contain a certain principle which cultivated soils lost in the process of time. In order to conceive the possibility of preserving, and even of increasing, the fertility of the soil without the intervention of dung, some knowledge of the laws of the nutrition of plants was indispensable. Liebig enunciated the principle that the action of manure was due to the presence of certain ingredients, of which chemical analysis served to indicate both the nature and the quantity. But he failed to make the progress he otherwise would have done because he did not adequately grasp the importance of the nitrogenous ingredients, for he held the view that all plants draw their nitrogen from the air. Subsequently it became recognised that the physical constitution of soils underwent some modification when year by year they were dressed exclusively with mineral manures, and that dung embodied, over and above its directly nutritive ingredients, a substance capable of maintaining in a desirable condition the physical properties of soils. This substance is the *organic matter*, which, by a series of changes, yields humic compounds..

What happens when these compounds are lacking in a soil has been experimentally demonstrated by M. von Zimmerman, upon his celebrated farm at Benkendorf, Saxony. A field was selected upon loamy soil, and the following rotation was practised, the object being to leave in the soil as little plant refuse as possible :—(1) Peas or potatoes ; (2) wheat (square-head) ; (3) sugar-beet ; (4) wheat (Rivett's bearded) ; (5) sugar-beet ; (6) barley. For a period of thirty years this field received none but chemical manures, and the crops yielded almost as well as those grown upon adjoining land. But the loamy soil, which, at the outset, was free-working and of medium consistency, became extraordinarily difficult to work. So much was this the case that the usual tillage operations proved ineffective, and it became necessary to resort to special means. The conditions, however, are not entirely the same in the case of sandy soils, in which the plants suffer from lack of cohesion amongst the particles. It has long been known that humus imparts cohesion to light soils, whilst it renders heavy soils more open.

The substances which enter into the formation of humus are capable of being added to the soil either in the form of manure, or of vegetable refuse, the latter consisting either of the residues of crops left in the soil or of green manures. Hence the needs of a cultivated soil may be said to embrace :—

<sup>1</sup> *Les Fermes sans Bétail en Allemagne*, par M. de Malliard, chargé d'une mission agricole spéciale.

1. A sufficient quantity of nutritive ingredients in an assimilable form.

2. The maintenance or improvement of the physical properties of the soil by means of organic matter.

Any question as to the first of these is already completely solved. In dung, the only chemical ingredients which need to be considered are nitrogen, phosphoric acid, and potash. The latter two are obtainable in the markets in all possible degrees of assimilability. A considerable variety of raw materials, or of by-products, which contain one or other of these two ingredients permits of great latitude in choosing the particular form in which each shall be applied. In the case of nitrogen, however, the problem is less simple. Although nitrates or salts of ammonia may always have been employed with success, at least upon soils of good quality, it is impossible to supply sandy or light soils with their nitrogen in an exclusively mineral form. The permeability of these soils is such that loss of nitrogen in the form of nitrates in the drainage waters cannot be avoided. Soils of this class are specially benefited by organic nitrogen,<sup>1</sup> such as the nitrogen contained in the residues left by crops, or in leguminous plants specially cultivated for the purpose. For such soils, nitrogen offered in this form is preferable to that in chemical manures and even to that in the ammoniacal salts of dung, for in both cases nitrification proceeds too rapidly, and there is consequent loss through the medium of the waters that drain away from the soil.

It appears therefore warrantable to assert that it is possible, without any difficulty, to find substitutes for the nutritive ingredients of dung, and that the latter need no longer be regarded as indispensable; also that it is further possible, at least upon soils subjected to a somewhat intensive treatment, to procure nitrogen by *sideration* (see page 874).

On the other hand, it is less easy to dispense with the organic matters of dung. By oxidation these yield, first humates, and afterwards carbonic acid, the last-named discharging a very important function in connection with the assimilation of nutritive ingredients by plants. Its intervention is naturally the less called for the more assimilable the form in which the manures are added to the soil, so that, in such case, it would be possible to dispense with the presence of organic matter. But there is no compensation for the absence of the physical effect of organic matter upon the constitution of the soil; hence the application of organic matter is absolutely necessary. It so happens that it is precisely the plants, whose function it is to accumulate nitrogen, that produce at the same time an enormous quantity of carbonaceous matter; moreover, even upon farms managed *sans bétail* (i.e., without live-stock), there are usually working animals, so that in practice the employment of dung becomes largely diminished rather than completely suppressed.

Hence it appears that cultivation by means of chemical fertilisers can be indefinitely continued only on the condition of supplying

---

<sup>1</sup> Organic nitrogen is defined as nitrogen in organic combination with carbon

organic matter to the soil, its presence being indispensable to the due maintenance of the physical properties of the latter. As a matter of fact, it is supplied either in the form of *crop residues* left in the land, or of *green manures*. To a certain extent, lime is competent to bring into activity the products of decomposition of organic matter.

The system of cultivation, based upon *sideration* and the employment of chemical manures, has passed beyond the tentative stage, for it has been attended with full success in the case of Schultz of Lupitz and his many imitators.

Let us pass now from the domain of theory to that of practice, and learn what are the plants that may be utilised as green manures upon light soils. Their function, it will be understood, is to obtain for the soil those ingredients which are most lacking—*nitrogen* and *humus*.

The first place belongs to the lupin. It will grow almost anywhere, even upon calcareous soils, and upon fields freshly dressed with marl. It is cultivated both as forage and as a catch crop. Hitherto the yellow-flowered lupin has been preferred by agriculturists, but, according to the recent experiments of Schirmer of Neuhaus, the white-flowered lupin is the more advantageous to use.

The kidney vetch, or ladies' fingers (*Anthyllis vulneraria*, L.) "works wonders" upon light soils well marled, and already moderately supplied with nitrogen and phosphoric acid.

One of the vetches, *Vicia villosa*, has yielded the best results upon the farm at Neuhaus.

Serradella (*Ornithopus sativus*) is also capable of rendering great service, provided it is allowed time in which to establish itself. The microbes discovered by Hellriegel, which give rise upon the roots to the minute nodules "in which the atmospheric nitrogen is transformed into protoplasm," are rarely present, at the commencement of growth, in sufficient numbers. It is possible, however, to inoculate the soil by means of samples of earth obtained from a field where serradella has already been successfully grown. Such inoculation ought to be regarded as a necessary preliminary in every new cultivation of leguminous plant. Failure in the practice of *sideration* is often to be attributed to the absence of these microbes.

Species of *Lathyrus* (meadow vetchling) are likewise capable of playing an important rôle.

The various plants that have been enumerated furnish, in the process of catch-cropping—independently of the root and stubble residues, which may be estimated to form one-third of the weight of the entire crop—a yield in dry matter varying from 2,500 to 5,000 kilogrammes, whilst dung, even at the rate of 10,000 kilogrammes per hectare annually,<sup>1</sup> does not furnish the soil with more than 2,000 kilogrammes of organic matter.

---

<sup>1</sup> 1 kilogramme = 2.2 lb.; 1 hectare = about 2½ acres. In the figures given, however, it is the *proportions*, and not the actual quantities, that are significant.



Green manuring, then, advantageously provides light soils at once with nitrogen and with organic matter, and it is more economical than the use of dung. Moreover, the system of Schultz of Lupitz is certainly preferable from a pecuniary point of view.

These practices are less suited to beet-root soils, submitted to a system of intensive culture, on account of the rotations which are followed. *Sideration* is, further, least satisfactory upon soils of medium consistency, which should be dressed with dung, supplemented by chemical manures. The employment of lime would, in case of need, serve to make good for a time any deficiency of organic matter.

In order to procure, in the case of strong lands, the humic matter indispensable to the mellowing of the soil, it is necessary to have recourse to processes of the same kind. M. Arndt, for example, cultivated with great success, upon the system of Schultz of Lupitz, the farm of Oberwartha, situated on very compact soil. His fields, which are in perfect condition, receive annually, in addition to the *plantes sidérées*, such as have been named, 400 kilogrammes of basic cinder, containing 20 per cent. of phosphoric acid, and 600 kilogrammes of kainit, yielding 13 per cent. of potash [presumably per hectare].

The lupin succeeds admirably at Oberwartha, and thus disposes of the prejudiced view that this plant is suited only to sandy soils. The white and blue flowered varieties have done best, the former as a crop grown for seed, the latter as a crop suited to the poorest soils, where other varieties of lupin refuse to grow.

Upon elevated lands, where rye is not cleared off the fields till the end of July, and where early frosts would be liable too soon to terminate the growth of the lupin, serradella is preferred. It is sown broadcast in April or May, in the cereal crop. If the latter is spring sown, then one sowing is made to suffice for both corn and serradella. M. Arndt inoculated his fields with microbe—*le microbe d'Helldriegel*—in spite of which the serradella did not succeed upon his very stiff soils, and it was necessary to resort to vetch and to crimson clover (“trifolium”). This last-named plant, cultivated solely in view of *sideration*, and sown in July and August upon land which had been subjected to the merest stirring of the surface, afforded in April and May an excellent green manure for potatoes.

To the plants already named may be added the melilot (Bokhara clover), the extensively developed root-system of which offers, on the one hand, the advantage of enriching the soil in organic matter, and, on the other hand, the inconvenience of sending up in the following year innumerable shoots which are difficult to extirpate. It is sown in the autumn in a crop of rye.

According to M. Arndt, a great future is in store for *Lathyrus* and certain wild forms of vetch.

If for any reason it is wished to suspend, or to avoid, the cultivation of nitrogen-accumulating plants, it is competent to fall back upon plants such as white mustard, which store up and retain in the arable layer of the soil the nitrogen added in a

mineral form, and therefore very soluble. According to Wagner's researches, a hectare of white mustard is capable, in the space of some weeks, of combining in its organic matter the nitrogen of 800 kilogrammes of nitrate of soda.

From what has been said, and in view of the experiments of M. Arndt, the conclusion is drawn that the system of *sideration* employed by Schultz of Lupitz upon light soils is equally applicable to heavy soils. All kinds of soils, particularly such as have been but little favoured by nature, are capable of being rendered of enhanced value by the aid of green manures.

From an economic point of view it is, however, necessary to take into consideration the facilities for marketing farm produce. By reducing the live stock, the volume of the products which have to be conveyed to market is necessarily enlarged. The application of *sideration* must, therefore, to some extent depend upon the density of population in the country, and upon the proximity of towns, and of railways or canals.

In the foregoing translation of a communication ("Farms without Live-stock in Germany"), which appears in the *Bulletin* (No. 5, 1891) of the French Ministry of Agriculture, I have followed the author pretty closely. The reader will have gleaned in the course of the article that the process of *sideration* is involved in our familiar practice of *green manuring*, when leguminous crops are employed for the latter purpose. The word "*sideration*" (Lat. *sidus*, a star) is presumably intended to convey the idea that the plants concerned obtain their nitrogen from outside the solid part of the earth—from, in fact, the atmosphere which envelopes it.

All the nitrogen-storing plants that have been named are, it will have been observed, *leguminous* species. Only the kidney vetch and "*trifolium*" (*Trifolium incarnatum*, L.) are natives of Britain, but the other species named are all capable of cultivation in this country.

Not only, however, are these plants all leguminous species, but they belong exclusively to one group of the Leguminosæ. Botanists have separated the plants of the great natural order Leguminosæ into three divisions, called respectively the Papilionaceæ, the Cæsalpinieæ, and the Mimoseæ. All British leguminous species, and all the leguminous plants mentioned in this paper, are members of the division Papilionaceæ. Consequently, in this country, the term *leguminous* is practically equivalent to *papilionaceous*. The locust-bean is an example of the Cæsalpinieæ, and the "*sensitive plant*" of the Mimoseæ.

*Sideration* suggests another development of the many-sided nitrogen question.

W. FREAM.

---

## OBITUARY.

### THE DUKE OF DEVONSHIRE, K.G.

Born April 27, 1808: Died December 21, 1891.

By the death of the seventh Duke of Devonshire, not only is the Royal Agricultural Society deprived of one of the very earliest of its members, but the nation at large loses a nobleman of great distinction and remarkable gifts. Other biographies will do justice to his commanding talents and his high position amongst his fellow-countrymen; the present notice must of necessity be confined to a statement of the services which he has rendered to agriculture during his long and useful life.

Born on April 27, 1808, he succeeded in 1834 to the earldom of Burlington; and in May 1838, at the age of thirty, he was one of the very first who gave in their adhesion to the infant Society for the general advancement of agriculture, which was then founded by Earl Spencer, the Duke of Richmond, and other notables of the time. The Earl of Burlington's name appears in the first list of Governors and Members of the English Agricultural Society that was ever published—and the only survivors of those first subscribers are now Sir Harry Verney, Bart. (the nonagenarian "Father of the Society"), Earl Grey, K.G., Lord Charles J. F. Russell, Mr. T. B. Saunders, and Lord Winmarleigh.

The Duke has, ever since 1838, remained a Governor of the Royal Agricultural Society, and at the meeting of the Council held on March 6, 1890, he was, with other original members of the English Agricultural Society, elected a Foundation Life Governor.

He first joined the Council on February 6, 1867, when, on the motion of the then President (Mr. H. S. Thompson), seconded by Lord Tredegar, he was elected to fill the vacancy caused by the promotion of Sir Edward Kerrison to be Vice-President. Not long after, in April 1869, he was, on the motion of Mr. John Dent Dent, seconded by Mr. H. S. Thompson, elected a Vice-President to fill the vacancy caused by the death of Sir J. V. B. Johnstone, Bart., M.P. At the very next meeting of the Council, held on May 5, 1869, he was nominated as President for the year 1869-70, and he assumed office after the highly successful Meeting held under the presidency of H.R.H. the Prince of Wales at Manchester, retiring at the Oxford Meeting of 1870.

The Duke's year of office was, on the whole, a somewhat uneventful one; but during his presidency, the Council came to the highly

important decision to publish quarterly cases of impure feeding-stuffs and manures analysed in the Society's laboratory, and the system of farm competitions was started through the liberality of Mr. James Mason, then High Sheriff of Oxfordshire, who offered a piece of plate, value 100 guineas, for the best managed farm in the locality.

The Oxford Meeting was also interesting as being the second visit paid by the Society to the city where it held its famous first meeting in 1839. On the earlier occasion, seven acres sufficed for the Showyard, and the prizes amounted to 790*l.* In 1870, the Show occupied 60 acres of ground, and the prizes for live stock amounted to 3,130*l.*, besides 395*l.* and ten silver medals for implements. The entries of stock had increased from 266 in 1839 to 1,377 in 1870, and the implements, instead of being described in one single octavo page, with room to spare, numbered 7,851 entries, with 359 exhibitors.

The Duke made on his Lancashire estate extensive reclamations of land from Morecambe Bay ; but it is as a breeder of the highest class of shorthorns that, as an agriculturist, he will be chiefly remembered. At his seat at Holker there has been for half a century one of the choicest and highest bred Bates herds in the world. At the public luncheon given on the occasion of his last sale on September 5, 1889, His Grace, in responding to the toast of his health, proposed by another distinguished shorthorn breeder, Sir Nigel Kingscote, said—"It was now very many years since he first began to take interest in shorthorns. His first venture in that line was in 1841. It had been his good fortune to have a first-rate adviser in his agent, Mr. Drewry, and he had thus become possessed of a herd which he ventured to describe as one of very considerable renown, and one highly esteemed amongst agriculturists, whether in this country or other parts of the world, who took an interest in shorthorns and appreciated the value of them accordingly."

Situated on the shores of Morecambe Bay, the fine soil and climate of Holker, and its sheltered situation, render it one of the best breeding establishments in the kingdom, and no pains have been spared, either in the introduction of the best blood or in the management of the animals. The bulk of the herd traces to a cow, Oxford 15th, purchased when a heifer at Earl Ducie's sale in 1853 for 200 guineas, and to Lady Oxford 5th, bought at the Havering Park sale in 1867 for 600 guineas. The prolific nature of these two cows, the excellence of their produce, and their great quality, have given the herd a world-wide reputation ; and at the periodical sales of the surplus stock they have realised extraordinary prices, and have gone to all parts of the world.

The successive sales at Holker, over a period of forty years, give the history of the development and rise of the breed ; for between the first sale and that of 1878, there was a difference on the average as between 25*l.* and 664*l.* On September 12, 1851, in order to lay the foundation for a superior herd of cattle at Holker, the late Mr. Trafford, the shorthorn auctioneer, sold the entire existing

stock. Holker at that time was difficult of access, there being no railway, and the 56 head sold for 1,407*l.*—an average of 25*l.* 2*s.* 6*d.* At the next sale, on September 9, 1864, Mr. Strafford was able to announce that Holker was within half a mile of the Furness railway. At this sale three females made three figures each—the six-year-old “Countess of Barrington,” sold for 155 guineas to Mr. D. Reynolds Davies; her three-year-old daughter went to Mr. H. J. Sheldon for 135 guineas; and Cleopatra 5th sold for 130 guineas to Mr. J. Logan. Duke of Oxford 12th, two years old, sold for 210 guineas; and Duke of Oxford 14th, a yearling bull, was sold to Mr. J. Fawcett of Scaleby Castle for 155 guineas. Thirty head sold for 1,984*l.* 10*s.*—an average of 66*l.* 3*s.*

The next sale was seven years after, in 1871, when a still larger increase was obtained. Then 31 cows and heifers averaged 248*l.* 2*s.*; 12 bulls and bull calves averaged 221*l.* 11*s.*; the 43 head sold for 10,349*l.* 17*s.*, or a general average of 240*l.* 13*s.* 10*d.*, an advance on the previous sale of 174*l.* 10*s.* 10*d.* a head. Three years later, in 1874, at another sale, 28 cows and heifers averaged 462*l.* 8*s.* 3*d.*; 15 bulls and bull calves, 236*l.* 13*s.* 11*d.*; 43 head made 16,497*l.* 12*s.*, or a general average of 383*l.* 13*s.* 3*d.*, an increase upon the last sale of 142*l.* 19*s.* 5*d.* per head. This was the highest draft sale up to that day. Shortly before this sale a meeting of Shorthorn breeders had been held in Willis’s Rooms to form a Society to purchase from Mr. Strafford the copyright of Coates’ Herd Book, and to carry on the Herd Book for the future. The Duke of Devonshire took the chair at this meeting “by general acclamation,” and was subsequently elected the first President of the Shorthorn Society of Great Britain and Ireland, which was the outcome of the meeting.

In 1878 there was another sale. This was the year after the sensational Windermere sale, when the Hon. M. H. Cochrane obtained 8,400 guineas for two Duchess heifers. Mr. Drewry rightly anticipated a sale at which the zenith of prices for shorthorns seemed to be reached, for eighteen cows and heifers averaged 794*l.* 11*s.* 2*d.*, and twelve bulls and bull calves 486*l.* 7*s.* 9*d.* Thirty head realised the large total of 19,922*l.* 14*s.*, and the average was 664*l.* 1*s.* 10*d.*, showing an increase in four years upon the average of 280*l.* 8*s.* 7*d.* At this sale seven animals made four figures:—“Grand Duchess of Oxford 21st” went to Lord Penrhyn for 1,550 guineas; “Grand Duchess of Oxford 22nd” to Mr. McCulloch (Australia) for 2,100 guineas; “Baroness Oxford 5th” to Mr. McIntosh for 2,660 guineas; “Grand Duchess of Oxford 38th” to Sir John Swinburne for 1,450 guineas; “Grand Duchess of Oxford 30th” to Mr. S. P. Foster, of Killhow, for 1,600 guineas; “Duke of Oxford 44th” to Mr. H. A. Brassey for 1,650 guineas, and “Duke of Oxford 45th” to Lord Fitzhardinge for 1,500 guineas. Between this sale and that held in 1883, no less than 10,000*l.* was received at Holker from private sales.

The following Table shows the results of the seven sales held at Holker during the time the herd has been in the able hands of Mr. Drewry:—

Year	Head sold	Average			Total of Sale		
		£	s.	d.	£	s.	d.
1851	56	25	2	6	1,407	0	0
1864	30	66	3	0	1,984	10	0
1871	43	240	13	10	10,349	17	0
1874	43	383	13	3	16,497	12	0
1878 <sup>1</sup>	30	664	1	10	19,922	14	0
1883	45	167	3	0	7,524	6	0
1889	38	104	13	0	3,981	12	0

<sup>1</sup> At this sale of 1878, nine "Oxfords" went for 14,726*l.* 5*s.*, or an average of 1,636*l.* 5*s.* apiece, six cows and heifers going at an average of 1,787*l.* 12*s.* 6*d.*, and three bulls at 1,333*l.* 10*s.*

The scene at the last sale in 1889 was described by a writer in the *Field* in language so picturesque that room must be found for it as a vivid description of the surroundings amongst which the Duke passed his life, and of the esteem in which he was held:—

In a paddock, in a pretty nook of that lake district of England where all is pretty that does not deserve a higher epithet of praise, there occurred "in the noon hour" of Thursday, September 5, a scene which will not be easily forgotten by those whose good fortune it was to witness it. The ground slopes now this way and now that; in spots the rock shows through; and, in spots, heavy-foliaged trees grow with sufficient luxuriance to prove that what soil there is good, and is in plenty too, if the roots can but penetrate to find it. All over the paddock were scattered some five or six hundred people; among whom the red, white, and roan shorthorns (which occupy the farm) were being paraded for inspection, showing gaily among the sober-coated masses of spectators. Suddenly, by some whispered message from one to another, the cattle were left, and the company thronged in a crowd to the exit and formed in two lines, down the middle of which passed a figure very characteristic and noteworthy even in a period which has produced many notable old men. The scene was Holker; the spot the field adjacent to the village school; and it was the aged Duke of Devonshire who slowly passed along, whilst everyone's hat was raised, to receive a courteous acknowledgment in return. Is there, except Prince Moltke, in Europe a man of more various fame? Some men thought of him as the owner of a name of great traditions; of estates in many counties, liberal and trusted in all; some remembered him as the sire of sons who have made great names in politics, and made even greater sacrifices for the nation's weal; some—as the occasion required—bore in mind that he was the successful breeder for more than half a century of a variety of cattle of which it is no extravagance to say that its fame goeth through the world. Yet Nature is stronger than all beside. The grave face one looked upon, the stooping figure, the eyes still full of light, were those not so much of a man of rank and wealth—though there was ample evidence of both—as of the student who has loved and followed learning for her own sake: of the man who, nearly sixty years ago, was the first mathematician of his year in the University of Cambridge; and is still her honoured Chancellor.

No words need be added to this picture to prove that in the death of the Duke of Devonshire, the nation has lost one of its noblest, most gifted, and most honoured sons.

ERNEST CLARKE.

## RECENT AGRICULTURAL INVENTIONS.

*The subjects of Applications for Patents from Sept. 17 to  
Dec. 16, 1891.*

N.B.—When the Invention is a communication from abroad, the name of the Inventor is shown in italics, between parentheses, after the name of the applicant.

**Agricultural Machinery and Implements, &c.**

No. of Application.	Name of Applicant.	Title of Invention.
15931	MARSHALL, J.	Threshing machines.
15942	BAMLETT, A. C.	Harvesters.
16007	"	"
16316	FAIRWEATHER, J.	Topping, tailing, and lifting turnips.
16357	SMITH, T., & BAILEY	Crushing potatoes, turnips, &c.
16376	GRAY, W.	Gathering potatoes.
16588	BIRRELL, K.	Potato raising and gathering machine.
16618	MANN, H.	Hay-making machine.
16619	LIVONIUS, O. VON	Drilling and sowing machine.
16623	WHITE, F. J.	Protecting cut crops from storms.
16841	GRAY, W.	Potato digger and gatherer.
17141	HORNSBY and others	Harvesting machines.
17248	BOARDMAN, J. W.	Potato-digging apparatus.
17370	PEARSON, A. N.	Spraying implement for crops.
17894	KEANE, F. H.	Mowing machines.
17984	LEE, F. W.	Digging and screening potatoes.
18769	DEW, J.	Elevators for chaff-cutters.
19082	HUNTER, T.	Horse-hoes, &c.
19087	MARTIN, D., & BRITON, W.	Feeding cut hay, &c., into a chop-mixing machine.
19236	DRURY, J.	Self-binding reapers.
19882	ROGERSON & LINLEY	Root-washer.
19956	HORNSBY, J., and others	Sheaf-binding harvesters.
20348	PETTEE, J. B.	Root-cutting machines.
20872	SLEEP, W. H., and anr.	Hay-tedding machine.
21131	BOULT ( <i>Hofherr</i> )	Filling sacks from threshing machines.
21419	BAMBER, J.	Pressing hay, straw, &c.
21734	TOM, J. P.	String reel and holder for binders.
21842	WALLER, A. D.	Harrow.
21945	PICHNO, W.	A spade plough.

## Stable Utensils and Fittings—Horse-shoes, &amp;c.

No. of Application.	Name of Applicant.	Title of Invention.
16318	CHAMPION, J. B.	Feed-bags for horses.
16325	PENDLETON, D.	Horse-shoes.
16386	DIX, H. A.	Non-slipping horse-shoe.
16539	BUTT, E.	Horse-feed nose-bag.
16561	BRICKNELL, S. E.	Hame tugs.
17061	PRITCHETT, G. E.	Horse-shoes.
16998	KNIGHT, A. W.	„
17242	D'ANVERS	Horse-shoes and shoeing.
17326	SMITH, H. G., & ROLFE.	A hinge horse-collar.
17480	FRASER, J.	Saddles.
17710	SMALL, J.	Disconnecting runaway horses from vehicles.
17797	HILL, J. & T.	Horse-collars.
17945	DE PERROT, C.	False collar for breast-plate harness.
18130	LEE, J.	Woollen waterproofs for horses.
18225	WESTON, B. S.	Safety buckle for stirrup leathers.
18260	INSTONE, A. E.	Roughing or caulking horse-shoes.
18484	SMALLMAN, J. W.	( <i>Power and others</i> ) Safety stirrup.
18581	MACREA, C. A.	Combined hames and horse-collars.
18652	ARTHUR, W. A.	Saddles.
18932	MCKENZIE, J.	Horse-shoe.
19034	PAGE, M., & JACKSON.	Fixing horse-shoes without nails.
19063	THOMAS, D.	Pads for preventing slipping in horses.
19890	BROWN, J. W.	Reins and bridles.
20093	PASSMORE & COLE	Fasteners for hames and collars.
20157	CARDOT, E.	Currycombs.
20289	REZELINS, J.	Pads for horses' hoofs.
20347	SHEATHER, C.	Pneumatic horse-shoe pads.
20538	CHALLINOR, C.	Horse-shoes to prevent slipping.
60684	MCQUAT, A. M.	Nose-bags.
20765	BRIDGMAN, H. H.	Non-slipping horse-shoes.
21236	HATFIELD, A., and others.	Equalising the draft of horses.
21415	HIGGINS, and others	Horse-shoe calks.
21452	RUSSELL, A. C.	Hames.
21458	PEACOCK & JACKMAN	Stirrups.
21462	RICHARDS, and others	Saddles.
21796	SMITH, T. G., and anr.	Ladies' saddles.
21807	SANKEY.	Saddles.
21867	RUSSELL, A. C.	Hames.
22205	WALLIS, J.	Splint for supporting horses' legs.



**Carts and Carriages.**

No. of Application.	Name of Applicant.	Title of Invention.
17970	MESNIL, J. . . .	Axles and axle-boxes.
18925	DEACON, O. D. . . .	Self-acting brake.
18982	MUNRO, D. R., and anr.	Seats for dog-carts.
21721	CHALMERS, J. . . .	Shifting, &c., cart bodies on their frames.
21726	MARTIN, H. . . .	Improved skid for coaches, &c.

**Dairy Utensils, &c.**

17348	GRAHAM, A. T. . . .	Milk-can protector.
17489	LAVERTON, E. . . .	Railway milk-churns.
18064	STRUTHERS & WEIR . . .	Milking appliance.
18480	GRAY, J. . . .	Milk strainers.
19133	BRADFORD, T. . . .	Butter-working apparatus.
20250	COTTON, G. . . .	Railway milk-cans.
20555	KEBB, R. F. . . .	Butter-printing machine.
20889	SHIELS, A. . . .	Automatically regulating the vacuum pressure in milking machines.
20956	JOHNSTONE, W. . . .	Detecting foreign fats in butter.
20959	SALENIUS . . . .	Centrifugal apparatus for use in butter-making.
20989	DUNCAN, J. H. H. . . .	Manufacture of butter.
21372	CARNBICK, J. . . .	Manufacture of Koumiss compounds, &c.
21890	RIMELL, S. . . .	Tool for working butter.

**Poultry and Game, &c., Appliances.**

15903	WALKER, W. A. . . .	Combined coop and feeder.
15955	MACKEAN & BOOTHBY . . .	Preserving eggs.
17717	MILLS, B. J. B. ( <i>De la Vieuxville</i> ) . . . .	Preserving eggs.
17968	TUNNARD, H. S. . . .	House, &c., for rearing chickens.
18631	SMITH, E. . . .	Self-feeder for poultry and game.
18968	BOWLES, W. A. . . .	Poultry houses.
21144	JONES, C. A. . . .	Regulating the temperature in incubators.
21317	LONGSHAW, J. . . .	Preserving eggs.
21619	DOUGLAS, T. . . .	Appliance for feeding pheasants, &c.

**Miscellaneous.**

15827	PAVY, E. H. . . .	Corn bins.
16289	MUNDAY, J. . . .	Protecting turnips from fly, &c.
18937	REDFERN, G. F. ( <i>Wolseley</i> ) . . . .	Sheep-shearing machines.

No. of Application.	Name of Applicant.	Title of Invention.
18978	LINGFORD, H. B. & E.	Apparatus for feeding calves.
20054	COLE, W.	Facilitating the shearing of sheep.
20395	ROBERTSON, A.	Sheep dip.
20520	BURGON, C.	Shearing and clipping machinery.
20952	COLE, W.	Shearing sheep, clipping horses, &c.
21056	EDWARDS, E.	Attaching, &c, animals in stables.
21367	JACOB, F.	Apparatus for feeding young cattle.
21525	CANNON, W. J.	Apparatus for dipping sheep, &c.

**Numbers of Specifications relating to the above subjects Published since Sept. 14, 1891<sup>1</sup>**

(with prices in parentheses).

Specifications of 1890.

10622 (6*d.*), 12773 (6*d.*), 13680 (6*d.*), 14351 (6*d.*), 14797 (6*d.*), 15014 (6*d.*)  
 15046 (8*d.*), 15121 (4*d.*), 15369 (6*d.*), 15580 (4*d.*), 15935 (6*d.*), 16477  
 (6*d.*), 16561 (8*d.*), 16613 (6*d.*), 16751 (6*d.*), 17004 (8*d.*), 17234 (6*d.*)  
 17749 (8*d.*), 17891 (6*d.*), 17911 (6*d.*), 18071 (6*d.*), 18529 (6*d.*), 18586  
 (6*d.*), 18987 (6*d.*), 19168 (8*d.*), 19410 (11*d.*), 19731 (6*d.*), 19913 (8*d.*),  
 19971 (8*d.*), 20427 (6*d.*), 20443 (11*d.*), 20500 (6*d.*), 20579 (6*d.*), 20626  
 (8*d.*), 20696 (6*d.*), 20733 (6*d.*), 20837 (8*d.*), 21137 (6*d.*), 20399 (8*d.*).

Specifications of 1891.

152 (6*d.*), 307 (8*d.*), 313 (4*d.*), 338 (8*d.*), 362 (8*d.*), 487 (6*d.*), 831 (6*d.*), 850  
 (6*d.*), 1276 (11*d.*), 1468 (6*d.*), 1724 (1*s.* 7*d.*), 2720 (4*d.*), 3321 (8*d.*), 3498  
 (4*d.*), 4127 (4*d.*), 8553 (1*s.* 10*d.*), 8773 (8*d.*), 9195 (6*d.*), 9527 (8*d.*), 9703  
 (1*s.* 3*d.*), 10963 (6*d.*), 12246 (4*d.*), 12371 (8*d.*), 12704 (6*d.*), 13654 (6*d.*),  
 13972 (6*d.*), 14319 (11*d.*), 17717 (4*d.*), 17968 (6*d.*), 18225 (6*d.*)

<sup>1</sup> Copies may be obtained at the Patent Office (Sale and Store Branch), 38 Cursitor Street, London, E.C.

## STATISTICS AFFECTING BRITISH AGRICULTURAL INTERESTS.

A summary of the Agricultural Returns of Great Britain, 1891 is given in Tables I. and II. on this and the following page.

**TABLE I.**—*Acreege under each kind of Crop, Bare Fallow, and Grass as returned upon June 4 in the Years 1891 and 1890 in Great Britain; with Total for the United Kingdom.*

		GREAT BRITAIN		UNITED KINGDOM, including ISLE OF MAN and CHANNEL ISLANDS	
		1891	1890	1891	1890
		acres	acres	acres	acres
<b>TOTAL AREA OF LAND AND WATER</b>		56,786,199	56,786,199	77,799,793	77,799,793
<b>TOTAL ACREAGE under ALL KINDS of CROPS, BARE FALLOW, and GRASS (a)</b>		32,918,514	32,768,335	48,179,473	48,045,755
<b>CORN CROPS.</b>	Wheat . . . . .	2,307,277	2,386,336	2,392,245	2,483,595
	Barley or Bere . . . . .	2,112,798	2,111,178	2,298,978	2,300,994
	Oats . . . . .	2,899,129	2,902,998	4,128,127	4,137,790
	Rye . . . . .	46,640	54,826	60,148	69,458
	Beans . . . . .	354,702	358,413	359,039	362,242
	Peas . . . . .	204,277	219,382	204,972	220,170
	<b>TOTAL . . . . .</b>	<b>7,924,823</b>	<b>8,033,133</b>	<b>9,443,509</b>	<b>9,574,249</b>
<b>GREEN CROPS.</b>	Potatoes . . . . .	532,794	529,661	1,296,763	1,321,272
	Turnips and Swedes . . . . .	1,918,535	1,947,598	2,227,050	2,251,220
	Mangel . . . . .	354,704	331,288	406,930	378,313
	Cabbage, Kohl Rabi, & Rape . . . . .	156,891	159,761	207,260	213,165
	Vetches or Tares . . . . .	228,258	233,071	234,210	239,310
	Other Green Crops . . . . .	106,387	96,149	138,440	130,865
	<b>TOTAL . . . . .</b>	<b>3,297,569</b>	<b>3,297,528</b>	<b>4,510,653</b>	<b>4,534,145</b>
<b>CLOVER, SAINFOIN, and GRASSES under Rotation.</b>	For Hay . . . . .	2,130,124	2,292,194	2,737,850	2,938,680
	Not for Hay . . . . .	2,586,458	2,516,625	3,275,835	3,158,530
	<b>TOTAL . . . . .</b>	<b>4,716,582</b>	<b>4,808,819</b>	<b>6,013,685</b>	<b>6,097,210</b>
<b>PERMANENT PASTURE or GRASS. Not broken up in Rotation. (b)</b>	For Hay . . . . .	4,503,108	4,778,639	5,973,757	6,248,352
	Not for Hay . . . . .	11,930,742	11,238,853	21,593,906	20,867,073
	<b>TOTAL . . . . .</b>	<b>16,433,850</b>	<b>16,017,492</b>	<b>27,567,663</b>	<b>27,115,425</b>
<b>FLAX . . . . .</b>	1,801	2,455	76,477	99,326	
<b>HOPS . . . . .</b>	56,145	54,555	56,145	54,555	
<b>SMALL FRUIT (c) . . . . .</b>	58,704	46,234	(d) 60,138	(d) 46,733	
<b>BARE FALLOW or Uncropped Arable Land . . . . .</b>	429,040	508,119	451,203	524,112	

(a) Not including nursery grounds, woods, and plantations, or unenclosed mountain and heath land.

(b) Exclusive of unenclosed mountain and heath land.

(c) Gooseberries, strawberries, and other small fruit, including what is grown between trees in orchards, and also in market gardens.

(d) Not including Ireland.

TABLE II.—*Number of Horses, Cattle, Sheep, and Pigs as returned upon June 4 in the Years 1891 and 1890.*

		GREAT BRITAIN		UNITED KINGDOM, including ISLE OF MAN and CHANNEL ISLANDS	
		1891	1890	1891	1890
HORSES (including Ponies).	Used solely for Agriculture	No. 1,022,936	No. 981,275	} Cannot be separately distinguished.	
	Unbroken Horses	401,257	393,915		
	Mares kept solely for breeding	64,210	57,430		
	<b>TOTAL</b>	<b>1,488,403</b>	<b>1,432,620</b>	<b>2,026,170</b>	<b>1,964,911</b>
CATTLE.	Cows and Heifers in Milk or in Calf	2,657,054	2,537,990	4,117,707	3,956,220
	Other Cattle. } 2 Years and above	1,504,649	1,439,119	2,473,808	2,361,424
	} Under 2 Years	2,691,118	2,531,523	4,752,171	4,472,214
	<b>TOTAL</b>	<b>6,852,821</b>	<b>6,508,632</b>	<b>11,343,686</b>	<b>10,789,858</b>
SHEEP.	1 Year old and above	17,786,941	16,756,568	20,614,807	19,332,472
	Under 1 Year old	10,945,617	10,515,891	12,919,181	12,334,723
	<b>TOTAL</b>	<b>28,732,558</b>	<b>27,272,459</b>	<b>33,533,988</b>	<b>31,667,195</b>
PIGS.		2,888,773	2,773,609	4,272,764	4,362,040

*Table showing the Estimated Total Production of Hops in the Years 1891 and 1890, in each County in which Hops were grown.*

COUNTIES	Estimated total produce		Acreage		Estimated average yield per acre	
	1891	1890	1891	1890	1891	1890
Berks . . . . .	cwt. 77	cwt. 58	acres 11	acres 11	cwt. 7·00	cwt. 5·27
Gloucester . . . . .	130	22	25	2 11	5·20	2·00
Hants . . . . .	13,793	19,104	2,749	2,614	5·02	7·31
Hereford . . . . .	44,170	22,473	6,560	2 6,077	6·73	3·70
Kent . . . . .	271,347	175,008	34,266	33,525	7·92	5·22
Notts . . . . .	20	29	14	14	1·43	2·07
Salop . . . . .	577	336	112	2 98	5·15	3·43
Suffolk . . . . .	118	13	20	2 25	5·90	0·52
Surrey . . . . .	14,212	9,025	1,955	1,874	7·27	4·82
Sussex . . . . .	67,861	43,599	7,150	6,787	9·49	6·42
Worcester . . . . .	24,411	13,962	3,280	2 2,925	7·44	4·77
<b>Total . . . . .</b>	<b>436,716</b>	<b>283,629</b>	<b>1 56,142</b>	<b>2 53,961</b>	<b>7·78</b>	<b>5·26</b>

<sup>1</sup> This acreage does not agree with that previously published, owing to three acres in the county of Cambridge and three acres in Hants having been originally returned in error.  
<sup>2</sup> See footnote on page 656 of the present Volume.

# Royal Agricultural Society of England.

(Established May 9, 1838, as the ENGLISH AGRICULTURAL SOCIETY, and Incorporated by Royal Charter on March 26, 1840.)

## Patron.

(Letter from Secretary of State, dated March 6, 1840.)

HER MOST GRACIOUS MAJESTY THE QUEEN.

President for 1890—1891.

THE EARL OF RAVENSWORTH.

## Trustees.

Year when  
elected on  
Council

1879	H.R.H. THE PRINCE OF WALES, K.G., <i>Marlborough House, Pall Mall.</i>
1838-40 } 1855	ACLAND, Rt. Hon. Sir THOMAS DYKE, Bart., <i>Killerton, Exeter, Devonshire.</i>
1858	BRIDPORT, Genl. Viscount, K.C.B., <i>Cricket St. Thomas, Chard, Somerset.</i>
1861	CATHCART, Earl, <i>Thornton-le-Street, Thirsk, Yorkshire.</i>
1861	DENT, JOHN DENT, <i>Ribston Hall, Wetherby, Yorkshire.</i>
1871	EGERTON OF TATTON, Lord, <i>Tatton Park, Knutsford, Cheshire.</i>
1863	KINGSCOTE, Col. Sir NIGEL, K.C.B., <i>Kingscote, Wotton-under-Edge, Gloucestershire.</i>
1854-59 } 1862	MACDONALD, Sir ARCHIBALD K., Bart., <i>Woolmer Lodge, Liphook, Hants.</i>
1856	POWIS, Earl of, <i>Powis Castle, Welshpool, Montgomeryshire.</i>
1852-57 } 1866	RICHMOND AND GORDON, Duke of, K.G., <i>Goodwood, Chichester, Sussex.</i>
1869	RIDLEY, Sir M. W., Bart., M.P., <i>Blagdon, Cramlington, Northumberland.</i>

## Vice-Presidents.

1889	H.R.H. Prince CHRISTIAN, K.G., <i>Cumberland Lodge, Windsor, Berkshire.</i>
1872-74 } 1884	CHAPLIN, Rt. Hon. HENRY, M.P., <i>Blankney Hall, Lincoln.</i>
1867	DEVONSHIRE, Duke of, K.G., <i>Holker Hall, Lancashire.</i>
1876	FEVERSHAM, Earl of, <i>Duncombe Park, Helmsley, Yorkshire.</i>
1881	GILBEY, WALTER, <i>Elsenham Hall, Essex.</i>
1872	LATHOM, Earl of, <i>Lathom Hall, Ormskirch, Lancashire.</i>
1848	LAWES, Sir JOHN BENNET, Bart., <i>Rothamsted, St. Albans, Herts.</i>
1865	LOPES, Rt. Hon. Sir MASSEY, Bart., <i>Maristow, Roborough, Devon.</i>
1880	MORETON, Lord, <i>Sarsden House, Chipping Norton, Oxon.</i>
1874	SPENCER, Earl, K.G., <i>Althorp, Northampton.</i>
1881	THOROLD, Sir JOHN H., Bart., <i>Syston Park, Grantham, Lincolnshire.</i>
1870	WHITEHEAD, CHARLES, <i>Barming House, Maidstone, Kent.</i>

## List of Council of the Society.

## Other Members of Council.

Year when elected on Council	
1881	*ALLENDER, G. MANDER, 31 <i>St. Petersburg Place, Bayswater, Middlesex.</i>
1862-66 } 1877 }	ARKWRIGHT, J. HUNGERFORD, <i>Hampton Court, Leominster, Herefordshire.</i>
1880	*ASHWORTH, ALFRED, <i>Tabley Grange, Knutsford, Cheshire.</i>
1890	BEACH, JOSEPH, <i>The Hattons, Wolverhampton, Staffordshire.</i>
1871	*BOWEN-JONES, J., <i>Ensdon House, Montford Bridge, Salop.</i>
1890	BROUGHAM AND VAUX, Lord, <i>Brougham Hall, Penrith, Cumberland.</i>
1886	*CAIRD, JAMES A., <i>Northbrook, Micheldever, Hants.</i>
1874	*CHANDOS-POLE-GELL, H., <i>Hopton Hall, Wirksworth, Derbyshire.</i>
1883	CLAY, CHARLES, <i>Walton Grange, Wakefield, Yorkshire.</i>
1885	*COVENTRY, Earl of, <i>Croome Court, Severn Stoke, Worcestershire.</i>
1887	*CRUTCHLEY, PERCY E., <i>Sunninghill Park, Berkshire.</i>
1888	*DARBY, ALFRED, <i>Little Ness, Shrewsbury, Shropshire.</i>
1886	*DE LAUNE, C. DE L. FAUNCE, <i>Sharsted Court, Sittingbourne, Kent.</i>
1882	EMLYN, Viscount, <i>Golden Grove, Carmarthen, S. Wales.</i>
1879	FOSTER, S. P., <i>Killhow, Carlisle, Cumberland.</i>
1875	FRANKISH, WILLIAM, <i>Limber, Uleby, Lincolnshire.</i>
1879	*GORRINGE, HUGH, <i>Kingston-by-Sea, Brighton, Sussex.</i>
1879	GRENVILLE, R. NEVILLE, <i>Butleigh Court, Glastonbury, Somersetshire.</i>
1889	*HAMOND, ANTHONY, <i>Westacre, Swaffham, Norfolk.</i>
1888	HORNSBY, JAMES, <i>Stapleford Park, Melton Mowbray, Leicestershire.</i>
1876	*HOWARD, CHARLES, <i>Biddenham, Bedfordshire.</i>
1886	*MAINWARING, C. S., <i>Galltfaenan, Trefnant R.S.O., North Wales.</i>
1874	*MARTIN, JOSEPH, <i>Highfield House, Littleport, Isle of Ely, Camba.</i>
1884	*MILLER, T. HORROCKS, <i>Singleton Park, Poulton-le-Fylde, Lancashire.</i>
1886	MUNTZ, PHILIP ALBERT, M.P., <i>Dunsmore, Rugby, Warwickshire.</i>
1881	*PARKER, Hon. CECIL T., <i>Eccleston, Chester.</i>
1886	*PELL, ALBERT, <i>Hazelbeach, Northampton.</i>
1889	PIDGEON, DANIEL, <i>Walsingham House, Piccadilly, W.</i>
1888	PORTLAND, Duke of, <i>Welbeck Abbey, Worksop, Notts.</i>
1886	RANSOME, J. E., <i>Holme Wood, Ipswich, Suffolk.</i>
1871	RAWLENCE, JAMES, <i>Bulbridge, Wilton, Salisbury, Wilts.</i>
1889	*ROWLANDSON, SAMUEL, <i>Newton Morrell, Darlington, Yorkshire.</i>
1874	SANDAY, GEORGE H., <i>Langdale Lodge, Clapham Park, Surrey.</i>
1886	*SCARTH, W. T., <i>Staindrop House, Darlington, Durham.</i>
1886	*SMITH, ALFRED J., <i>Rendlesham, Woodbridge, Suffolk.</i>
1889	SMITH, HENRY, <i>The Grove, Cropwell Butler, near Nottingham.</i>
1889	SPEARMAN, Sir J. L. E., Bart., <i>Llansannon Court, Cowbridge, Glam.</i>
1882	STAFFORD, Marquis of, <i>Lilleshall, Newport, Salop.</i>
1891	*STANYFORTH, E. WILFRID, <i>Kirk Hammerton Hall, York.</i>
1875	STRATTON, RICHARD, <i>The Duffryn, Newport, Monmouthshire.</i>
1883	SUTTON, MARTIN J., <i>Kidmore Grange, Caversham, Oxon.</i>
1889	*TAYLOR, GARRETT, <i>Trowse House, Norwich.</i>
1890	*TERRY, JOSEPH P., <i>Berry Field, Aylesbury, Buckinghamshire.</i>
1889	TREMAXNE, JOHN, <i>Heligan, St. Austell, Cornwall.</i>
1882	WARREN, REGINALD AUGUSTUS, <i>Preston Place, Worthing, Sussex.</i>
1889	WHEELER, E. VINCENT V., <i>Newnham Court, Tenbury, Worcestershire.</i>
1889	*WILSON, C. W., <i>Rigmaden Park, Kirkby Lonsdale, Westmoreland.</i>
1865	*WILSON, Sir JACOB, <i>Chillingham Barns, Belford, Northumberland.</i>

\* Members of Council who retire by rotation, but who may be re-elected.

## STANDING COMMITTEES FOR 1891.

### Finance Committee.

KINGSCOTE, Col. Sir NIGEL (Chairman).	THOROLD, Sir J. H., Bart.
BRIDPORT, General Viscount.	FRANKISH, W.
RIDLEY, Sir M. WHITE, Bt., M.P.	SANDAY, G. H.

### House Committee.

CHAIRMAN of Finance Committee.	PARKER, Hon. C. T.
THE PRESIDENT.	WILSON, Sir JACOB.
BRIDPORT, General Viscount.	ALLENDER, G. M.

### Journal Committee.

CATHCART, Earl (Chairman)	DENT, J. D.
EMLYN, Viscount.	FRANKISH, W.
THOROLD, Sir J. H., Bart.	PELL, A.
ASHWORTH, A.	PIDGEON, D.
CAIRD, J. A.	SUTTON, MARTIN J.
DE LAUNE, C. DE L. FAUNCE.	WHITEHEAD, CHARLES.

### Chemical Committee.

EMLYN, Viscount (Chairman).	ARKWRIGHT, J. H.	PELL, A.
PARKER, Hon. C. T.	BOWEN-JONES, J.	SUTTON, MARTIN J.
ACLAND, Sir T. D., Bt.	CAIRD, J. A.	TERRY, J. P.
LAWES, Sir J. B., Bt.	DE LAUNE, C. DE L. FAUNCE.	VOELCKER, Dr.
MACDONALD, Sir A. K., Bt.	DENT, J. D.	WARREN, R. A.
SPEARMAN, Sir J. L. E., Bt.	GRENVILLE, R. N.	WHITEHEAD, CHAS.
THOROLD, Sir J. H., Bt.	HOWARD, C.	

### Seeds and Plant Diseases Committee.

WHITEHEAD, CHAS. (Chairman)	CAIRD, J. A.	MAINWARING, C. S.
THOROLD, Sir J. H., Bt.	CARRUTHERS, W.	ORMEROD, Miss E. A.
ARKWRIGHT, J. H.	DE LAUNE, C. DE L. FAUNCE.	PELL, A.
BOWEN-JONES, J.	FAUNCE.	STRATTON, R.
	HORNSBY, J.	WHEELER, F. V. V.

### Veterinary Committee.

THOROLD, Sir J. H., Bt. (Chairman)	CHANDOS-POLE-GELL, H.	MILLER, T. H.
BRIDPORT, General Viscount.	CLAY, C.	PELL, A.
MORETON, Lord.	COPE, A. C.	PRESIDENT OF ROYAL COLL. OF VETY.
PARKER, Hon. C. T.	CROOKSHANK, Prof.	SURGEONS.
KINGSCOTE, Col. Sir NIGEL.	DARBY, ALFRED	SIMONDS, Prof.
WILSON, Sir JACOB.	DENT, J. D.	SMITH, A. J.
ALLENDER, G. M.	FLEMING, Dr. GEORGE.	TERRY, J. P.
ASHWORTH, A.	FOSTER, S. P.	WHEELER, E. V. V.
AXE, Prof. J. WORTLEY.	HAMOND, A.	WILSON, C. W.
BEACH, JOSEPH.	MASTER OF FARRIERS' COMPANY.	
BROWN, Professor.		

### Stock-Prizes Committee.

SANDAY, G. H. (Chairman).	SPEARMAN, Sir J. L. E., Bt.	CRUTCHLEY, P. E.
H.R.H. Prince CHRISTIAN, K.G.	WILSON, Sir JACOB.	DARBY, ALFRED.
COVENTRY, Earl of.	ALLENDER, G. M.	FOSTER, S. P.
BROUGHAM and VAUX, Lord.	ARKWRIGHT, J. H.	FRANKISH, W.
MORETON, Lord.	ASHWORTH, A.	GILBEY, WALTER.
PARKER, Hon. C. T.	BOWEN-JONES, J.	GORRINGE, H.
	CHANDOS-POLE-GELL, H.	HOWARD, C.

**Stock-Prizes Committee (continued).**

MAINWARING, C. S.	SIMONDS, Professor.	TERRY, J. P.
MARTIN, JOSEPH.	SMITH, A. J.	TREMAYNE, J.
MILLER, T. H.	SMITH, HENRY.	WILSON, C. W.
MUNTZ, P. A., M.P.	STRATTON, R.	The Stewards of Live
ROWLANDSON, S.	TAYLOR, GARRETT.	Stock.

**Implement Committee.**

FRANKISH, W. (Chairman)	BEACH, JOSEPH.	RANSOME, J. E.
BRIDPORT, Gen. Viscount.	BOWEN-JONES, J.	ROWLANDSON, S.
MORETON, Lord.	CLAY, C.	SANDAY, G. H.
PARKER, Hon. C. T.	GRENVILLE, R. NEVILLE.	SMITH, A. J.
THOROLD, Sir J. H., Bt.	HORNSBY, J.	SMITH, HENRY.
WILSON, Sir JACOB.	HOWARD, C.	STRATTON, R.
ALLENDER, G. M.	MARTIN, JOSEPH.	The Stewards of Im-
ANDERSON, W.	PIDGEON, D.	plements.

**General Doncaster Committee.**

THE WHOLE COUNCIL, with the following representatives of the LOCAL COMMITTEE :—

DONCASTER, Mayor of.	CHAFFER, GEORGE.	WOOD, G. T.
FRANK, F. BACON.	CLARK, J. FIRTH.	YARBOROUGH, G. B. C.
	WHITE, JOHN.	

**Show-Yard Works Committee.**

WILSON, Sir JACOB (Chairman)	ASHWORTH, A.	HOWARD, C.
PARKER, Hon. C. T.	CLAY, CHARLES.	SANDAY, G. H.
ALLENDER, G. M.	FRANKISH, W.	STRATTON, R.
	HORNSBY, J.	

**Committee of Selection.**

CATHCART, Earl. (Chairman)	CAIRD, J. A.	GRENVILLE, R. N.
THOROLD, Sir J. H., Bt.	CHANDOS-POLE-GELL, H.	WARREN, R. A.
	CRUTCHLEY, P. E.	

And the Chairmen of the Finance, Journal, Chemical, Stock-Prizes, and Implement Committees.

**Education Committee.**

MORETON, Lord (Chairman).	DELAUNE, C. DE L. FAUNCE.	RANSOME, J. E.
EMLYN, Viscount.	DENT, J. D.	SUTTON, M. J.
KINGSCOTE, Col. Sir NIGEL.	FOSTER, S. P.	TREMAYNE, J.
ARKWRIGHT, J. H.	MAINWARING, C. S.	VOELCKER, Dr.
BOWEN-JONES, J.	PELL, A.	WHEELER, E. V. V.
CRAIGIE, Major.	PIDGEON, D.	

**Dairy Committee.**

PARKER, Hon. C. T. (Chairman)	ALLENDER, G. M.	MAINWARING, C. S.
BRIDPORT, Gen. Viscount.	ARKWRIGHT, J. H.	TAYLOR, GARRETT.
THOROLD, Sir J. H., Bt.	ASHWORTH, A.	VOELCKER, Dr.
	DARBY, ALFRED.	

\* \* \* The PRESIDENT is a Member *ex officio* of all Committees, and the TRUSTEES and VICE-PRESIDENTS are Members *ex officio* of all Standing Committees except the Committee of Selection.



Chief Officials of the Society.

Secretary and Editor—ERNEST CLARKE, 12 Hanover Square, W.  
 Consulting Chemist—Dr. J. AUGUSTUS VOELCKER, 12 Hanover Square, W.  
 Consulting Botanist—W. CARRUTHERS, F.R.S., F.L.S., 44 Central Hill, Norwood, S.E.  
 Consulting Entomologist—Miss E. A. ORMEROD, F.R.Met.Soc., Torrington House, Holywell Hill, St. Albans.  
 Consulting Veterinary Surgeon—Professor JAMES BEART SIMONDS, St. John's Villa, Ryde, Isle of Wight.  
 Veterinary Inspectors—THE OFFICERS OF THE ROYAL VETERINARY COLLEGE.  
 Consulting Engineers—EASTON & ANDERSON, LIM., 3 Whitehall Place, S.W.  
 Surveyor and Superintendent of Works—WILSON BENNISON, 66 Ashley Road, Crouch Hill, London, N.  
 Consulting Surveyor—GEORGE HUNT, Evesham, Worcestershire.  
 Publisher—JOHN MURRAY, 50A Albemarle Street, W.  
 Bankers—THE LONDON AND WESTMINSTER BANK, St. James's Square Branch.

GEOGRAPHICAL DISTRIBUTION OF MEMBERS OF THE COUNCIL AND OF GOVERNORS AND MEMBERS OF THE SOCIETY.

DISTRICTS	COUNTIES	NUMBER OF GOVERNORS AND MEMBERS	NUMBER OF MEMBERS OF COUNCIL	NAMES OF MEMBERS OF COUNCIL
A.	BEDFORDSHIRE . .	140	1	C. Howard.
	BUCKINGHAMSHIRE	134	1	Jos. P. Terry.
	CAMBRIDGESHIRE .	165	1	Joseph Martin.
	ESSEX . . . . .	246	1	Walter Gilbey, v.P.
	HERTFORDSHIRE .	205	1	Sir J. B. Lawes, v.P.
	HUNTINGDONSHIRE	56	—	
	MIDDLESEX . . .	609	2	G. M. Allender; Dan. Pidgeon.
	NORFOLK . . . .	347	5	{ H.R.H. the Prince of Wales, K.G., T.; Anthony Hamond; Garrett Taylor.
	OXFORDSHIRE . .	157	2	{ Lord Moreton, v.P.; M. J. Sutton.
	SUFFOLK . . . .	246	2	J. E. Ransome; A. J. Smith.
	—2305	—14		
B.	CUMBERLAND . .	190	2	{ Lord Brougham and Vaux; S. P. Foster.
	DURHAM . . . .	202	2	{ Earl of Ravensworth, P. ; W. T. Scarth.
	NORTHUMBERLAND	317	2	{ Sir M. White Ridley, T. ; Sir Jacob Wilson.
	WESTMORELAND .	80	1	C. W. Wilson.
	—789	—7		
C.	DERBYSHIRE . . .	192	1	H. Chandos-Pole-Gell.
	LEICESTERSHIRE .	159	1	J. Hornsby.
	LINCOLNSHIRE . .	311	3	{ Sir J. H. Thorold, v.P. ; Rt. Hon. H. Chaplin, v.P. ; W. Frankish.
	NORTHAMPTONSHIRE	179	2	Earl Spencer, v.P. ; A. Pell.
	NOTTINGHAMSHIRE	259	2	H. Smith ; Duke of Portland.
RUTLAND . . . .	36	—		
	—1136	—9		

DISTRIBUTION OF MEMBERS OF THE SOCIETY—*continued.*

DISTRICTS	COUNTIES	NUMBER OF GOVERNORS AND MEMBERS	NUMBER OF MEMBERS OF COUNCIL	NAMES OF MEMBERS OF COUNCIL
D.	BERKSHIRE . . .	289	2	{ H.R.H. Prince Christian, K.G., v. P.; P. E. Crutchley.
	CORNWALL . . .	157	1	
	DEVONSHIRE . . .	214	2	{ Sir T. D. Acland, T.; Sir M. Lopes, v.P.
	DORSETSHIRE . . .	90	—	
	HAMPSHIRE . . .	232	2	{ Sir A. K. Macdonald, T.; J. A. Caird.
	KENT . . . . .	460	2	
	SOMERSETSHIRE . . .	146	2	{ Visct. Bridport, T.; R. Neville Grenville.
	SURREY . . . . .	316	1	
	SUSSEX . . . . .	323	3	{ Duke of Richmond and Gordon, K.G., T.; H. Gorringe; R. A. Warren.
WILTSHIRE . . . . .	157	1	J Rawlence.	
		2334	— 16	
E.	YORKSHIRE . . . . .	778	6	{ Earl Cathcart, T.; J. D. Dent, T.; Earl of Feversham, v.P.; C. Clay; S. Rowlandson; E. W. Stanyforth.
			— 6	
F.	GLOUCESTERSHIRE . . .	310	1	{ Col. Sir Nigel Kingscote, T. J. H. Arkwright.
	HEREFORDSHIRE . . .	165	1	
	MONMOUTHSHIRE . . .	43	1	{ J. Bowen-Jones; A. Darby; Marquis of Stafford.
	SHROPSHIRE . . . . .	415	3	
	STAFFORDSHIRE . . .	283	1	Jos. Beach.
	WARWICKSHIRE . . .	254	1	P. A. Muntz, M.P.
	WORCESTERSHIRE . . .	252	2	{ Earl of Coventry; E. V. V. Wheeler.
SOUTH WALES . . . . .	197	2	Viscount Emlyn; Sir J. L. E. Spearman.	
		1919	— 12	
G.	CHESHIRE . . . . .	337	3	{ Lord Egerton, T.; A. Ashworth; Hon. Cecil T. Parker.
	LANCASHIRE . . . . .	452	3	
	NORTH WALES . . . . .	230	2	{ Earl of Powis, T.; C. S. Mainwaring.
		1019	— 8	
SCOTLAND . . . . .		228		
IRELAND . . . . .		166		
CHANNEL ISLANDS . . . . .		16		
FOREIGN COUNTRIES . . . . .		165		
HONORARY MEMBERS . . . . .		19		
		594		
GRAND TOTAL . . . . .		10924	— 72	

## GOVERNORS OF THE SOCIETY.

	Date of election as Member	Date of election as Governor
H.R.H. THE PRINCE OF WALES, K.G....Marlborough House, Pall Mall, S.W., and Sandringham . . . . .	—	Feb. 3, 1864
H.R.H. THE DUKE OF EDINBURGH, K.G....Clarence House, St. James's, S.W. . . . .	—	Aug. 6, 1884
H.R.H. THE DUKE OF CAMBRIDGE, K.G....Gloucester House, Piccadilly, W. . . . .	—	Aug. 6, 1862
H.R.H. PRINCE CHRISTIAN OF SCHLESWIG-HOLSTEIN, K.G....Cumberland Lodge, Windsor . . . . .	—	Aug. 4, 1875
ACLAND, Rt. Hon. Sir T. Dyke, Bart...Killerton, Exeter . . . . .	May 29, 1838	Mar. 3, 1875
ALLCROFT, Herbert John...Stokesay Court, Onibury, Salop . . . . .	—	Dec. 12, 1888
ALLCROFT, John D....108 Lancaster Gate, W. . . . .	April 2, 1862	June 29, 1870
ALLENDER, G. Mander...Stammerham, Horsham . . . . .	June 1, 1859	May 7, 1890
AMHERST, W. A. Tyssen, M.P....Didlington Hall, Brandon . . . . .	Feb. 2, 1859	May 7, 1890
ARKWRIGHT, J. Hungerford...Hampton Court, Leominster . . . . .	—	June 5, 1861
SHBURTON, Lord...The Grange, Alresford, Hants. . . . .	—	May 7, 1890
BAILLIE, W. Hunter...48 Norfolk Square, Hyde Park, W. . . . .	July 18, 1838	Mar. 5, 1890
BATH, The Marquis of...Longleat, Warminster . . . . .	—	July 6, 1853
BATHURST, Earl...Cirencester House, Gloucestershire . . . . .	—	Nov. 3, 1887
BATTEN, John...Yeovil . . . . .	July 16, 1839	Mar. 5, 1890
BECTIVE, Earl of, M.P....Underley Hall, Kirkby Lonsdale . . . . .	—	July 1, 1868
BENN, Thomas G....Reigny House, Newton Reigny, Penrith . . . . .	Mar. 13, 1878	Aug. 2, 1882
BORTHWICK, Sir Algernon, Bart., M.P....Heath House, Hamp- stead Heath, N.W. . . . .	—	Dec. 12, 1888
BRADFORD, Earl of...Weston Park, Shifnal . . . . .	Mar. 7, 1860	Mar. 3, 1875
BRASSEY, Henry A....Preston Hall, Aylesford . . . . .	July 5, 1865	May 7, 1873
BRIDPORT, Gen. Viscount, K.C.B....Cricket St. Thomas, Chard . . . . .	Jan. 19, 1842	April 2, 1862
BROOKS, Sir William Cunliffe, Bart....Barlow Hall, Chorlton- cum-Hardy, Manchester . . . . .	—	Aug. 7, 1872
BROWNE, Alexander H. T....Callaby Castle, Alnwick . . . . .	—	Mar. 6, 1872
BURTON, Lord...Rangemore, Burton-on-Trent . . . . .	Nov. 7, 1888	June 25, 1890
BADOGAN, Earl...Culford Hall, Bury St. Edmunds . . . . .	—	Dec. 11, 1889
BALTHORPE, Lord...Elvetham, Winchfield . . . . .	Aug. 6, 1862	June 3, 1874
CALVERT, Frederick, Q.C....38 Upper Grosvenor Street, W. . . . .	Feb. 13, 1839	Mar. 5, 1890
CATHCART, Earl...Thornton-le-Street, Thirsk . . . . .	Feb. 6, 1856	April 3, 1867
CAWDOR, Earl of...Stackpole Court, Pembrokeshire . . . . .	Nov. 17, 1841	Mar. 3, 1875
CHAPLIN, Rt. Hon. Henry, M.P....Blankney Hall, Lincoln . . . . .	—	Nov. 2, 1870
CLIFDEN, Viscount...Holdenby House, Northampton . . . . .	—	July 3, 1889
CLINTON, Lord...Heanton Satchville, Beaford, N. Devon . . . . .	April 3, 1867	April 2, 1890
CLITHEROW, Colonel Edward J. S....Hotham Hall, Brough, Yorkshire . . . . .	—	Feb. 6, 1889
CLUTTON, John...9 Whitehall Place, S.W. . . . .	Dec. 15, 1838	Mar. 5, 1890
COLMAN, J. J., M.P....Carrow House, Norwich . . . . .	June 1, 1870	Feb. 6, 1889
CORBETT, John, M.P....Impney, Droitwich . . . . .	July 2, 1873	Feb. 4, 1891
CORNWALLIS, Fiennes S. W., M.P....Linton Park, Maidstone . . . . .	—	July 2, 1884

Elected a Foundation Life Governor March 5, 1890.

† Life Governor.

	Date of election as Member	Date of election as Governor
COTES, Charles Cecil...Woodcote, Newport, Salop . . . . .	—	Dec. 6, 1876
†COWPER, Earl...Panshanger, Hertford . . . . .	—	April 7, 1875
CROOKSHANK, Prof. E. M....Saint Hill, East Grinstead . . . . .	—	Nov. 6, 1889
DARNLEY, Earl of...Cobham Hall, Gravesend . . . . .	—	May 5, 1852
D'AUMALE, H.R.H. The Duke...Wood Norton, Evesham . . . . .	—	April 7, 1875
†DARTMOUTH, Earl of...Patshull Hall, Wolverhampton . . . . .	—	Aug. 3, 1859
DE LAUNE, C. de L. Faunce...Sharsted Court, Sittingbourne . . . . .	—	Nov. 6, 1878
†DENT, John Dent...Ribston Hall, Wetherby . . . . .	July 2, 1851	Feb. 3, 1875
†DERBY, Earl of, K.G....Knowsley, Prescott . . . . .	July 31, 1849	Mar. 5, 1890
DERWENT, Lord...Hackness Hall, Scarborough . . . . .	—	April 7, 1869
*DEVONSHIRE, Duke of, K.G....Holker Hall, Grange, Lancs. . . . .	—	May 12, 1838
†DICKSON-POYNTER, Sir J., Bart....Hartham Park, Corsham, Wilts. . . . .	Nov. 2, 1887	April 2, 1890
*DREWITT, R. Dawtrey...Peppering House, Arundel . . . . .	Mar. 11, 1840	Mar. 5, 1890
†DUNMORE, Earl of...Dunmore, N.B. . . . .	—	Feb. 3, 1869
†DURHAM, Earl of...Lambton Castle, Durham . . . . .	—	July 14, 1880
EGERTON OF TATTON, Lord...Tatton Park, Knutsford . . . . .	Mar. 6, 1872	Nov. 7, 1883
†ELLESMERE, Earl of...Worsley Hall, Manchester . . . . .	—	July 7, 1869
*ELLMAN, Robert H....61 North Street, Lewes . . . . .	Feb. 13, 1839	Mar. 5, 1890
*ESSEX, Earl of...Cassibury Park, Watford . . . . .	Dec. 11, 1839	Feb. 23, 1842
EVANS, John Carbery...Hatley Park, Gamlingay, Cambs. . . . .	—	Feb. 4, 1891
EVANS, Sir Thomas W., Bart. . . . .Allestree Hall, Derby . . . . .	July 19, 1843	Feb. 4, 1857
EYRE, George Bramston...Welford Park, Newbury, Berks . . . . .	—	March 6, 1889
FEVERSHAM, Earl of...Duncombe Park, Helmsley . . . . .	Mar. 5, 1862	Mar. 3, 1875
FIFE, Duke of, K.T....15 Portman Square, W. . . . .	—	Nov. 7, 1888
FITZWILLIAM, Earl, K.G....Wentworth Woodhouse, Rotherham . . . . .	—	June 5, 1872
*FLETCHER, John Philip...Darby Lodge, Sunbury-on-Thames . . . . .	Feb. 19, 1840	Mar. 5, 1890
†FORTESCUE, Earl...Castle Hill, South Molton . . . . .	—	Nov. 6, 1861
FREAKE, Sir Thomas G., Bt....Warfleet, Dartmouth . . . . .	—	July 30, 1890
†FREELAND, H. W...Chichester . . . . .	—	May 5, 1852
†FREEMAN-MITFORD, A.B., C.B....Batsford Park, Moreton-in-the-Marsh, Gloucester . . . . .	—	Nov. 3, 1886
†FYTCHE, J. Lewis...The Terrace, Freshwater, Isle of Wight . . . . .	April 5, 1854	June 4, 1875
GILBEY, Walter...Elsenham Hall, Essex . . . . .	Nov. 2, 1870	June 5, 1888
†GILL, Reginald B.E....Bickham, Roborough, S. Devon . . . . .	July 2, 1884	Dec. 12, 1888
GILSTRAP, Sir W., Bart....Fornham Park, Bury St. Edmunds . . . . .	May 7, 1862	April 2, 1890
*GLOVER, John...28 Lichfield Street, Tamworth . . . . .	Jan. 10, 1840	Mar. 5, 1890
GOOCH, Sir Alfred S., Bart...Benacre Hall, Wangford, Suffolk . . . . .	—	July 13, 1888
GRAFTON, Duke of...Wakefield Lodge, Stoney Stratford . . . . .	—	June 3, 1888
†GRANT, Sir G. Macpherson, Bt....Ballindalloch Castle; N.B.. . . . .	April 1, 1863	April 2, 1885
*GREAVES, William...Bakewell . . . . .	Dec. 4, 1839	Mar. 5, 1885
*†GREY, Earl, K.G....Howick, Lesbury, Northumberland . . . . .	—	May 12, 1885
GRIFFITHS, John James...Highbury Grange, Highbury, N. . . . .	—	May 1, 1881
GWYNNE, John...Kenton Grange, The Hyde, N.W. . . . .	—	Mar. 5, 1881
†HARCOURT, E. W....Nuneham Park, Abingdon . . . . .	June 3, 1868	April 2, 1888
†HAREWOOD, Earl of Harewood House, Leeds . . . . .	—	Mar. 6, 1888
†HARTINGTON, Marquis of, M.P....Hardwick Hall, Chesterfield . . . . .	—	June 2, 1888
HENRY, Mitchell...Kylemore Castle, Co. Galway . . . . .	Nov. 7, 1877	Dec. 10, 1888
HERTFORD, Marquis of...Ragley Park, Alcester . . . . .	Aug. 2, 1882	May 7, 1888
†HEYWOOD, Sir T. Percival, Bart...Doveleys, Uttoxeter . . . . .	—	May 14, 1888

\* Elected a Foundation Life Governor March 5, 1890.

† Life Governor.

	Date of election as Member	Date of election as Governor
*†HOLFORD, R.S...Western Birt House, Tetbury . . . . .	—	Feb. 13, 1839
†HOTFIELD, Lord...Hothfield Place, Ashford . . . . .	—	May 7, 1879
*HOUBLON, R. Archer...Bartlow, Cambridge . . . . .	Jan. 10, 1840	Mar. 5, 1890
*†HULSE, Col. Sir Edward, Bt...Breamore Ho., Fordingbridge . . . . .	—	June 13, 1838
JOICEY, E...Blenkinsopp Hall, Haltwhistle, Northumberland . . . . .	—	Dec. 12, 1888
*KEMBLE, Thomas...Runwell Hall, Chelmsford . . . . .	July 10, 1839	Mar. 5, 1890
†KINGSCOTE, Col. Sir Nigel, K.C.B...Kingscote, Wotton-under-Edge, Gloucestershire . . . . .	April 6, 1854	July 1, 1874
†KNIGHT, Sir F. Winn., K.C.B...Wolverley House, Kidderminster	—	June 15, 1842
KOHLAPUR, H.H. The Maharajah of...Kohlapur, India . . . . .	—	Feb. 6, 1889
†LATHOM, Earl of...Lathom House, Ormskirk . . . . .	April 7, 1869	Nov. 6, 1872
†LAWES, Sir J. B., Bart...Rothamsted, St. Albans . . . . .	April 29, 1846	Dec. 11, 1878
†LECONFIELD, Lord...Petworth House, Sussex . . . . .	—	June 5, 1872
LEGH, William John...Lyne Park, Disley, Stockport . . . . .	—	Aug. 4, 1858
†LEICESTER, Earl of, K.G...Holkham Hall, Norfolk . . . . .	—	Nov. 15, 1843
†LEIGH, Lord...Stoneleigh Abbey, Kenilworth. . . . .	—	Dec. 1, 1858
†LONDESBOROUGH, Earl of...Londesborough Pk., Market Weighton	Nov. 5, 1862	April 2, 1890
†LONDONDERRY, Marquis of, K.G....Seaham Hall, Seaham Harbour, co. Durham . . . . .	—	June 3, 1885
†LONSDALE, Earl of...Lowther Castle, Penrith . . . . .	—	July 4, 1883
†LOPES, Rt. Hon. Sir Massey, Bart...Maristow, Roborough, Devon	Mar. 15, 1848	May 7, 1884
*LOVELACE, Earl of...East Horsley Towers, Leatherhead . . . . .	—	June 26, 1838
LOYD, Lewis...Monks Orchard, Bromley . . . . .	—	Mar. 1, 1865
LUCAS, Sir Thomas, Bart...12A Kensington Palace Gardens, W.	—	Dec. 12, 1888
†LUTTRELL, Col. H. A. F., C.B....Badgworth Ct., Axbridge R. S. O.	July 7, 1869	Mar. 5, 1890
*MACCLESFIELD, Earl of...Sherburn Castle, Tetsworth . . . . .	Aug. 8, 1838	Mar. 5, 1890
†MACDONALD, Sir A. K., Bart...Woolmer Lodge, Liphook . . . . .	July 31, 1849	Nov. 1, 1871
†MANVERS, Earl...Thoresby Park, Ollerton, Newark . . . . .	—	July 2, 1873
†MARLE, John...Bedford Lodge, Haverstock Hill, N.W. . . . .	Nov. 2, 1864	Mar. 5, 1890
†MARJORIBANKS, Rt. Hon. Edward, M.P....Ninewells, Cherside, N.B. . . . .	—	July 31, 1889
MIDDLETON, Lord...Birdsall House, York . . . . .	—	Mar. 3, 1875
MILDMAY, Francis B., M.P...Flete, Ivy Bridge, Devon . . . . .	—	Dec. 12, 1888
*MONCK, J. Bligh...Coley Park, Reading . . . . .	May 23, 1839	Mar. 5, 1890
†MORETON, Lord...Sarsden House, Chipping Norton, Oxon. . . . .	—	Mar. 3, 1875
†MORRISON, Alfred.. Fonthill House, Hindon, Wilts. . . . .	—	July 3, 1861
†MOUNT-EDGECUMBE, Earl of...Mount-Edgecumbe, Plymouth	Nov. 6, 1861	Mar. 5, 1890
†MUNTZ, George F...Umberslade Park, Birmingham . . . . .	Dec. 4, 1867	June 30, 1875
*NEAME, Frederick...Luton, Selling, Faversham . . . . .	Feb. 13, 1839	Mar. 5, 1890
NEELD, Sir John, Bart...Grittleton, Chippenham . . . . .	—	Feb. 3, 1875
NORMANTON, Earl of...Somerset, Ringwood, Hants. . . . .	—	Mar. 3, 1875
*NORTH, Rt. Hon. Col. J. Sidney...Wroxton Abbey, Banbury . . . . .	May 8, 1839	Mar. 5, 1890
†NORTHBROOK, Earl of...Stratton, Micheldever Station, Hants. . . . .	—	June 2, 1880
PAGET, Lord Alexander...The Oaklands, Tarporley, Cheshire . . . . .	July 6, 1881	July 3, 1889
†PEEL, Edmund...Brynypys, Ruabon . . . . .	Feb. 3, 1858	Mar. 5, 1890
*PINNEY, Col. William...30 Berkeley Square, W. . . . .	Mar. 13, 1839	Mar. 5, 1890
†PORTLAND, Duke of.. 3 Grosvenor Square, W. . . . .	—	June 1880
†PORTMAN, Viscount...Durweston, Blandford . . . . .	Aug. 6, 1862	Mar. 1890
†POWIS, Earl of...Powis Castle, Welshpool . . . . .	—	July 4, 1855

\* Elected a Foundation Life Governor March 5, 1890,

† Life Governor.

	Date of election as Member	Date of election as Governor
RAVENSWORTH, Earl of...Ravensworth Castle, Gateshead . . .	Feb. 5, 1868	July 1, 1885
REVELSTOKE, Lord...Membland, Plymouth . . . . .	—	June 4, 1890
*†RICHMOND & GORDON, Duke of, K.G...Goodwood, Chichester .	June 20, 1838	Dec. 2, 1868
†RIDLEY, Sir Matthew W., Bart., M.P....Blagdon, Cramlington .	Apr. 7, 1869	May 5, 1886
RIPON, Marquis of, K.G....Studley Royal, Ripon . . . . .	—	July 3, 1861
ROTHSCHILD, Lord...148 Piccadilly, W. . . . .	Nov. 7, 1888	June 4, 1890
*RUSSELL, Lord C. J. F....Drakelow Lodge, Woburn . . . . .	May 26, 1838	Mar. 5, 1890
†SALISBURY, Marquis of, K.G...Hatfield House, Herts . . . . .	—	Feb. 6, 1889
†SALT, Sir W. H., Bart....Maplewell, Loughborough . . . . .	Feb. 5, 1868	Mar. 5, 1890
SAVILE, Lord, G.C.B....Rufford Abbey, Ollerton, Notts. . . . .	—	Mar. 27, 1889
*SAUNDERS, T. B....The Priory, Bradford-on-Avon . . . . .	June 13, 1838	Mar. 5, 1890
†SCHRÖDER, Baron J. H. W....The Dell, Staines . . . . .	Nov. 3, 1869	April 2, 1890
†SEFTON, Earl of...Croxeth, Liverpool . . . . .	—	Dec. 8, 1869
*§SIMONDS, Prof. James Beart...St. John's Villa, Ryde, I. W. . . . .	July 25, 1838	Mar. 5, 1890
*SIMONDS, W. Barrow...Abbotts Barton, Winchester . . . . .	June 19, 1839	Mar. 5, 1890
*SMITH, Henry...The Chestnuts, Leamington . . . . .	June 19, 1839	Mar. 5, 1890
†SMITH, Rt. Hon. W. H., M.P...3 Grosvenor Place, S.W. . . . .	—	Apr. 5, 1882
†SMYTH, Sir J. H. Greville, Bart...Ashton Court, Bristol . . . . .	—	July 3, 1878
SOUBERBIELLE, Edouard...78 Cromwell Road, S.W. . . . .	—	Mar. 4, 1891
*SPARKS, William...Crewkerne . . . . .	June 6, 1838	Mar. 5, 1890
SPENCER, Earl, K.G...Althorp Park, Northampton . . . . .	Dec. 5, 1860	Mar. 3, 1875
†STAPYLTON, Major H. M....Myton Hall, Helperby, Yorks. . . . .	July 11, 1865	May 7, 1890
*STRATTON, J. Locke...Turweston House, Brackley . . . . .	May 13, 1839	Mar. 5, 1890
SUDELEY, Lord...Toddington, Winchcomb . . . . .	—	Nov. 5, 1879
SUFFIELD, Lord.. Gunton Park, Norwich . . . . .	July 1, 1868	Nov. 3, 1875
†SUTHERLAND, Duke of, K.G...Stafford House, St. James', S.W..	—	July 1, 1868
†SUTTON, John Manners...Kelham, Newark . . . . .	—	May 8, 1844
†SUTTON, Martin J...Kidmore Grange, Caversham, Oxon. . . . .	May 1, 1878	Feb. 1, 1882
†SWINBURNE, Sir John, Bart., M.P. Capheaton, Newcastle-on-Tyne	May 1, 1867	May 7, 1890
†TANQUERAY, John S...c/o W. Sweetland, 64 Jermyn St., S.W. . . . .	Feb. 16, 1848	May 8, 1849
†THOROLD, Sir John H., Bart....Syston Park, Grantham . . . . .	Aug. 5, 1868	May 1, 1889
TREDEGAR, Lord...Tredegar Park, Newport, Mon. . . . .	—	May 3, 1876
†TURBERVILL, Lt. Col. Picton...Ewenny Priory, Bridgend . . . . .	Feb. 7, 1872	Mar. 3, 1880
†TWEEDMOUTH, Lord...Brook House, Park Lane, W. . . . .	July 9, 1845	April 2, 1890
*VERNEY, Rt. Hon. Sir Harry, Bart....Clayden House, Winslow .	May 10, 1838	Mar. 5, 1890
†WANTAGE, Lord, V.C...Lockinge, Wantage . . . . .	June 3, 1863	May 1, 1872
†WARWICK, Earl of...Warwick Castle, Warwick . . . . .	—	June 1, 1859
WESTMINSTER, Duke of, K.G...Eaton Hall, Chester . . . . .	July 3, 1860	June 5, 1872
†WHITEHEAD, Charles...Barming House, Maidstone . . . . .	Apr. 1, 1857	Feb. 6, 1889
WILLOUGHBY DE BROKE, Lord...Kineton House, Warwick . . . . .	—	Dec. 10, 1890
WILLOUGHBY DE ERESBY, Lord...Normanton Park, Stamford . . . . .	Mar. 3, 1869	May 5, 1875
†WINDSOR, DE...Hewel Grange, Bromsgrove . . . . .	—	Nov. 6, 1878
*WINMARLEIGH, Lord...Winmarleigh, Garstang . . . . .	—	May 12, 1838
*WOOD, James...Ockley Manor, Keymer, Sussex . . . . .	Aug. 8, 1838	Mar. 5, 1890
†YERBURGH, Robert A., M.P...Billinge, Scarr, Blackburn . . . . .	—	Nov. 7, 1888

\* Elected a Foundation Life Governor March 5, 1890.

† Life Governor.

§ Honorary Member.

**HONORARY MEMBERS OF THE SOCIETY.**

*British Subjects or Foreigners who have rendered exceptional services to Agriculture or Allied Sciences, and who have been elected under Bye-law 8 as Honorary Members, without payment of subscription.)*

	Date of election as Ordinary Member	Date of election as Honorary Member
ANDERSON, William, D.C.L., M.Inst.C.E....Lesney Ho., Erith, Kent	Aug. 2, 1871	Nov. 6, 1889
BROWN, Professor George T., C.B....3 St. James's Square, S.W.	Dec. 3, 1862	May 1, 1878
HAIRD, Rt. Hon. Sir J., K.C.B....8 Queen's Gate Gardens, S.W.	July 2, 1851	Feb. 5, 1890
HANNFELT, Carl Juhlin...Consul-General of Sweden and Norway, 24 Great Winchester St., E.C.	—	Feb. 1, 1871
LEMING, George, LL.D., C.B....Cathcart Lodge, Tyrwhitt Road, St. John's, S.E.	—	Mar. 13, 1878
MILBERT, Dr. J. H., F.R.S....Harpenden, St. Albans	—	July 4, 1883
MOFMAN, Dr....10 Doroithien Strasse, Berlin	—	Mar. 4, 1846
MOHENBRUCK, Baron Arthur von...I Niebelungengasse 8, Vienna	—	Nov. 5, 1890
MECOUTEUX, M. Edouard...26 Rue Jacob, Paris	—	April 7, 1869
MASTEUR, Louis...Membre de l'Institut, 45 Rue Ulm, Paris	—	Aug. 1, 1883
MAYFAIR, Rt. Hon. Sir Lyon, K.C.B., M.P...68 Onslow Gdns., S.W.	—	July 6, 1842
ROSKOWETZ, Emanuel Ritter von, Senr....Kwassitz, Moravia	—	Nov. 5, 1890
WILEY, Prof. C. V., M.A., Ph.D....Department of Agriculture, Washington, U.S.A.	—	Dec. 7, 1887
ANDERSON, Dr. J. Burdon, F.R.S....Oxford	—	May 1, 1878
SCHLIEFFEN, Count...Schlieffenburg, bei Lalendorf, Mecklenburg, Germany	—	Dec. 12, 1883
MONDS, Prof. J. Beart...St. John's Villa, Ryde, Isle of Wight	July 25, 1838	Apr. 3, 1849
WHEEL, Dr. H....Privy Councillor and Director of the Depart- ment of Agriculture, 17 Lutherstrasse, Berlin	—	Aug. 1, 1883
WISSERAND, Eugène...Directeur de l'Agriculture, Ministère de l'Agriculture, 17 Rue du Cirque, Paris	—	Aug. 1, 1883
WILMORIN, Henry L. de...4 Quai de la Mégisserie, Paris	Aug. 2, 1879	June 4, 1890

**SUMMARY OF MEMBERS ON THE REGISTER,**

**DECEMBER 31, 1890.**

**34 Foundation Life Governors** (Members elected before the granting of the Charter on March 26, 1840).

**64 Governors** paying an annual subscription of 5*l*.

**82 Life Governors** who have compounded for their annual subscriptions.

**6,926 Members** paying an annual subscription of 1*l*.

**11 Members** who, having paid annual subscriptions for **50 Years**, have become Life Members.

**3,724 Life Members** who have compounded for their annual subscriptions.

**64 Life Members** by Examination.

**19 Honorary Members.**

**10,924 Total number of Governors and Members at December 31, 1890.**

## REPORT OF THE AUDITORS

### ON THE RELATIONS OF LIFE COMPOSITIONS TO REVENUE.

---

We have, as requested, carefully considered the question of the manner in which the Life Compositions received from Members in future are to be treated in the Society's accounts, and also the contributions to the revenue of each future year which should be made in respect of the Life Compositions received in the past.

2. *Annual Contribution to Revenue by Life Compounders.*—After examining and discussing several alternative plans, we are unanimously of opinion that the simplest, best, and fairest method will be to credit all Life Compositions received in and after 1890 to the Reserve Fund, and to debit that Fund each year with the cost of providing the Life Members then on the books with their privileges.

3. *Net Cost per Member.*—On the average of the last seven years (including 1890), the net cost of providing Members with their privileges (excluding all contingencies and the shows) was 14s. per head. This cost may, in view of the change of the Journal from a half-yearly to a quarterly publication, probably be larger instead of smaller in the future, but for the present it may be taken at 14s.

4. *Life Members who compounded before 1890.*—There were 3,825 Life Governors and Life Members on the register on January 1, 1890. Their privileges for the year at 14s. per head would cost 2,677l. 10s. Each future year will, of course, diminish by deaths the claims upon the Society of the Life Members who compounded before 1890 at the old rate of 10l., and whose compositions were credited to the revenue of the particular years in which they happened to be paid.

5. *Life Compounders of 1890.*—The total amount received for Life Compositions during 1890 was 1,895l. Of those who compounded in 1890, 133 exercised their privileges for that year, and the income of 1890 must be credited with 93l. 2s. ( $133 \times 14s.$ ) on their account.

6. *Life Members by Examination.*—In the above calculations we have included the fifty-eight Members who have been granted the Life Membership as a reward, having won first-class certificates at the Annual Senior Examinations during the twenty-one years from 1869 to 1889. We recommend that for the future a sum equal to what these Life Memberships would have cost if paid for by the candidates themselves (*i.e.* 15l. each) should be debited to the Education Grant, and credited to the Reserve Fund, in order to provide funds out of which the cost of the privileges of the Education Life Members elected after 1889 can be defrayed. We have so dealt in the accounts with the six Life Memberships conferred in June 1890, as the result of the Senior Examination held last May.

7. *Prospective Claims of Life Members elected before 1890.*—It may be useful, as giving an idea of the prospective claims upon the Society which



have to be met out of the present capital, to subjoin the following statement, showing the number of years that the 3,825 Life Governors and Life Members on the books on January 1, 1890, had already exercised their privileges:—

Year	Members	Year	Members	Year	Members	Year	Members	Year	Members
1838-40	35	1850	17	1860	19	1870	82	1880	127
1841	15	1851	23	1861	41	1871	81	1881	96
1842	21	1852	13	1862	92	1872	87	1882	144
1843	10	1853	27	1863	71	1873	102	1883	210
1844	7	1854	29	1864	52	1874	86	1884	217
1845	22	1855	21	1865	33	1875	148	1885	136
1846	19	1856	43	1866	26	1876	92	1886	101
1847	12	1857	29	1867	30	1877	93	1887	90
1848	14	1858	29	1868	46	1878	112	1888	114
1849	17	1859	30	1869	96	1879	262	1889	506

The gross number of years during which these 3,825 Members had already exercised their privileges on January 1, 1890, was 54,974, or  $14\frac{1}{3}$  years on the average. The experience of the last seven years (including 1890) shows that the average period which a Life Member remains on the books is twenty-six years. We might therefore have taken  $11\frac{2}{3}$  years as the average remainder of the lives of those who compounded before 1890, if the number that entered year by year had been fairly regular; but as an unusually large number entered in the year 1889, the total average must be raised to  $12\frac{2}{3}$  years. Some will live longer and some less than the average; but, to provide for all, we need such a sum as would yield 1*s.* for 3,825 Members for  $12\frac{2}{3}$  years; calculating interest at  $2\frac{3}{4}$  per cent., 28,750*l.* is required. We desire to draw special attention to the fact that the amount of the Society's funded capital, 30,000*l.* New Consols (valued at 29,062*l.* 10*s.* on January 1, 1890), was little more than sufficient to meet the future cost of providing its Life Members with the privileges which by its acceptance of their Life Compositions it has contracted to give them.

8. *Quinquennial Investigation suggested.*—As the Life Composition has been raised from 10*l.* to 15*l.*, it is not improbable that there may in the future be some change in the average duration of Life Membership. We think it will be well, therefore, to follow the example of life insurance companies, and at intervals of five years to re-investigate the two questions of (1) the average duration of Life Membership, and (2) the annual cost of Members' privileges.

9. *Recommendation.*—In framing the Statements of Account for the year 1890, which we herewith append with our certificate that they are correct, we have followed the plan indicated above, as we are of opinion that the Council and the Members generally will thus be enabled to estimate more closely the available income upon which they can properly count in a particular year, and to see more clearly than before whether the Society's assets and liabilities are increasing or diminishing; and whether, therefore, the Society is financially stronger or weaker at the end of each year's operations.

Signed { FRANCIS SHERBORN,  
A. H. JOHNSON,  
C. G. ROBERTS.

March 2, 1891.



SOCIETY OF ENGLAND.

xv

DECEMBER 31, 1890.

Cr.

	£	s.	d.	£	s.	d.
By 30,000 <i>l.</i> NEW CONSOLS (2 $\frac{3}{4}$ per cent.) at cost . . . . .				29,033	9	4
Value on 31st December, 1890, at 95 $\frac{1}{10}$ = 28,743 <i>l.</i> 15 <i>s.</i> 0 <i>d.</i> , [Of this 30,000 <i>l.</i> Stock, 105 <i>l.</i> is held against Special Prizes.]						
By BOOKS and FURNITURE (including 47 <i>l.</i> 1 <i>s.</i> 6 <i>d.</i> Furniture purchased in 1890) . . . . .	2,732	17	6			
By COUNTRY MEETING PLANT . . . . .	1,375	4	4			
By MACHINERY . . . . .	1,207	0	0			
				5,315	1	10
By Sundry DEBTORS . . . . .				104	11	4
By CASH IN HAND, December 31, 1890:						
Bankers . . . . .	1,736	13	1			
Secretary and Surveyor . . . . .	77	17	11			
				1,814	11	0
				36,267	13	6
Less: Sundry CREDITORS . . . . .	229	18	0			
Subscriptions paid in 1890, but belonging to 1891, and carried forward . . . . .	75	0	0			
Doncaster Show Account, carried forward to 1891 . . . . .	786	2	4			
				1,091	0	4

*Memorandum*:—The above Assets are exclusive of the amount recoverable in respect of arrears of Subscriptions to the 31st December, 1890, which amount to 793*l.*

£35,176 13 2

Examined, audited, and found correct, this 2nd day of March, 1891.

FRANCIS SHERBORN,  
A. H. JOHNSON,  
C. G. ROBERTS, } *Auditors on behalf of the Society.*

## Income.

	£ s. d.	£ s. d.
<b>ANNUAL SUBSCRIPTIONS:—</b>		
<i>Governors</i> : Received in 1889, but belonging to 1890 . . . . .	5 0 0	
Subscriptions for 1890 . . . . .	309 0 0	314 0 0
<i>Members</i> : Received in 1889, but belonging to 1890 . . . . .	75 0 0	
Subscriptions for 1890 . . . . .	6,037 7 0	
Subscriptions for previous years . . . . .	223 0 0	6,335 7 0
 <b>LIFE COMPOSITIONS:—</b>		
Contributions to Revenue (See Balance-Sheet)—3,958 Life Members at 14s. . . . .	...	2,770 12 0
 <b>RECEIPTS FROM PUBLICATIONS:—</b>		
Ordinary Sales of Journal for 1890 (less Publisher's charges) . . . . .	112 16 11	
Advertisements in Journal . . . . .	389 15 4	
Sales in Office of Back Numbers of Journal . . . . .	61 15 5	
Sale of Old Journals as waste . . . . .	113 10 0	
Sales of Pamphlets and Lists of Members . . . . .	66 6 3	744 3 11
 <b>LABORATORY FEES</b> . . . . .	...	772 19 5
 <b>RENTS FROM SUB-LETTING</b> . . . . .	...	210 0 0
 <b>INTEREST ON BANK BALANCES</b> . . . . .	...	81 15 7
		£11,228 17 11

ERNEST CLARKE, *Secretary.*  
WELTON JONES & CO., *Accountants.*

**Expenditure.**

	£	s.	d.	£	s.	d.
<b>GENERAL ADMINISTRATION:—</b>						
Salaries of Secretarial Staff (including Temporary Assistance) . . . . .	2,104	13	8			
Pensions to Officials . . . . .	190	0	0			
Professional Charges (Auditors, &c.) . . . . .	45	3	0			
House Rent, Taxes, House Expenses, and Repairs . . . . .	817	9	1			
Binding and Purchase of Books . . . . .	29	2	3			
Printing and Stationery . . . . .	386	18	7			
Postage and Telegrams . . . . .	214	4	6			
Carriage of Parcels, and Cabs . . . . .	37	14	6			
Advertising and Miscellaneous Office Expenses . . . . .	94	9	9			
				3,929	15	4
<b>JOURNAL OF SOCIETY:—</b>						
Printers' Bills for the four numbers of 1890 . . . . .	1,471	8	9			
Wood Engravings and Illustrations . . . . .	129	3	6			
Literary Contributions and Assistance . . . . .	603	12	7			
Postage, Packing, and Delivery . . . . .	705	2	4			
Miscellaneous Journal Printing . . . . .	55	9	11			
Miscellaneous Journal Expenses . . . . .	49	9	3			
				3,014	6	4
<b>PREPARATION, PRINTING, AND POSTAGE OF INDEX TO SECOND SERIES OF JOURNAL. . . . .</b>						
				457	10	10
<b>PRINTING OF PAMPHLETS . . . . .</b>						
				29	15	10
<b>PRINTING LIST OF MEMBERS . . . . .</b>						
				163	1	0
<b>LABORATORY:—</b>						
Salaries and Wages . . . . .	988	0	0			
Apparatus and Chemicals . . . . .	86	10	6			
Printing, Railway Travelling, and Sundry Expenses . . . . .	77	2	10			
				1,151	13	4
<b>OTHER SCIENTIFIC DEPARTMENTS:—</b>						
Consulting Botanist's Salary . . . . .	200	0	0			
Expenses of Inquiry into Pastures . . . . .	48	14	0			
Consulting Entomologist's Salary . . . . .	100	0	0			
Grant to Royal Veterinary College . . . . .	500	0	0			
Medals for Proficiency in Cattle Pathology . . . . .	2	14	0			
				851	8	0
<b>EDUCATION PRIZES AND SCHOLARSHIPS:—</b>						
Senior Examination: Money Prizes, 55 <i>l.</i> ; Six Life Memberships at 15 <i>l.</i> =90 <i>l.</i> . . . . .	145	0	0			
Fees to Examiners . . . . .	60	18	0			
Junior Examination: 10 Scholarships at 20 <i>l.</i> . . . . .	200	0	0			
Fees to Examiners . . . . .	15	15	0			
Advertising Examinations . . . . .	12	6	5			
Printing . . . . .	10	11	9			
				444	11	2
<b>SPECIAL EXPENSES:—</b>						
Further Contribution to Funds of Mansion House United Association on Railway Rates . . . . .	...			50	0	0
Grant to Registration Scheme of Farriers' Company . . . . .	...			50	0	0
Farm Prize Competition: Expenses of Judging . . . . .	...			309	2	11
Stallion Premiums, Gold Medals, and Expenses . . . . .	...			708	5	5
Total Expenditure . . . . .	...			£11,159	10	2
Balance carried to Balance Sheet . . . . .	...			69	7	9
				£11,228	17	11

Examined, audited, and found correct, this 2nd day of March, 1891.  
 FRANCIS SHERBORN, }  
 A. H. JOHNSON, } Auditors on behalf of the Society.  
 C. G. ROBERTS, }

Dr.

## (B) STATEMENT OF RECEIPTS

Corresponding figures for Nottingham, 1888.		£	s.	d.	£	s.	d.
2,000	<b>SUBSCRIPTION:—</b>						
	From Plymouth Local Committee . . . . .				2,000	0	0
	<b>CATALOGUES:—</b>						
242	Extra Lines in Implement Catalogue . . . . .	60	10	6			
	Woodcuts for New Implements . . . . .	5	10	0			
							66 0 0
173	Advertisements in Catalogues . . . . .						173 4
	<b>FEES FOR ENTRY OF IMPLEMENTS:—</b>						
3,542	Implement Exhibitors' Payments for Shedding . . . . .	2,859	15	0			
166	Non-Members' Fees for Entry of Implements . . . . .	134	0				
							2,993 15
	<b>FEES FOR ENTRY OF LIVE STOCK:—</b>						
	By Members:—1,445 Entries @ 5s. . . . .	361	5	0			
	57 Post Entries @ 10s. . . . .	28	10	0			
	By Non-members:—248 Entries @ 1l. . . . .	248	0	0			
	8 Post Entries @ 2l. . . . .	16	0	0			
830							653 15
395	Fees for Horse Boxes and Stalls . . . . .						242 10
	<b>FEES FOR ENTRIES OF POULTRY:—</b>						
118	By Members:—101 Entries . . . . .	12	12	6			
	By Non-members:—564 Entries . . . . .	148	5	0			
	Entries of Table Poultry, 26 @ 1s., 3 @ 2s. . . . .	1	12	0			
							162 9
	<b>OTHER ENTRY FEES:—</b>						
19	Non-Members' Fees for Entries of Produce . . . . .						46 1 0
	Fees for Entry in Horse-shoeing Competition . . . . .						8 1 0
5	Deposits of Competitors forfeited . . . . .						2
	<b>MISCELLANEOUS RECEIPTS:—</b>						
187	Fines for non-exhibition of Live Stock . . . . .	114	5	0			
	Fines due from previous Shows . . . . .	7	15	0			
							122 0
339	Premiums for Supply of Refreshments . . . . .						385 0
50	Premiums for Cloak Rooms and Lavatories . . . . .						50 0
8,060	Carried forward . . . . .				8,905	0	0

Corresponding figures for Plymouth, 1888.		COST OF ERECTION OF SHOW-YARD:—		£	s.	d.	£	s.	d.
3,774		Timber . . . . .		4,336	1	7			
257		Ironmongery, 118 <i>l.</i> 6 <i>s.</i> 9 <i>d.</i> ; Hurdles, 26 <i>l.</i> 6 <i>s.</i> 8 <i>d.</i> . . . . .		382	13	5			
66		Paints, Oil, Glass, Lead, &c. . . . .		59	13	0			
24		Bricks, Lime, Cement, Coals, &c. . . . .		87	6	2			
1,315		Canvas, Roofing, Cloth Felt, Baize, &c. . . . .		1,197	0	1			
605		Railway Charges, 304 <i>l.</i> 2 <i>s.</i> 11 <i>d.</i> ; Horse Hire, 103 <i>l.</i> 8 <i>s.</i> 0 <i>d.</i> . . . . .		407	10	11			
78	{	Stationery, Postage, and Telegrams . . . . .		62	6	2			
		Insurance, 31 <i>l.</i> 2 <i>s.</i> 0 <i>d.</i> ; Sleepers, 29 <i>l.</i> 0 <i>s.</i> 0 <i>d.</i> . . . . .		60	2	0			
1,842		Wages . . . . .		1,841	11	6			
595		Superintendent of Works: Salary and Expenses . . . . .		652	18	0			
				3,957	2	10			
		Less:—							
2,836		Sale of Materials . . . . . £2,607 0 8							
1,523		Work for Exhibitors and Purveyors . . . . . 1,328 5 2							
				3,935	5	10			
4,199							5,151	17	0
		<b>EXPENSES OF SECRETARY'S DEPARTMENT:—</b>							
		Expenses of Inspection Committee . . . . .		41	2	1			
12		Secretary's Journeys to Plymouth and Expenses . . . . .		11	10	11			
93	{	Expenses for Clerks, 121 <i>l.</i> 8 <i>s.</i> 2 <i>d.</i> ; Preparation of Catalogues, } 26 <i>l.</i> 3 <i>s.</i> 10 <i>d.</i> . . . . .		147	12	0			
								200	5
		<b>PRINTING:—</b>							
392	{	Printing of Prize Sheets, Certificates, Admission Orders, Parch- } ment Numbers, Circulars to Exhibitors, Prize Cards, Mem- } bers' Tickets, and Miscellaneous . . . . .		331	3	4			
			Secretary's Local Printing . . . . .		14	3	6		
5		Programmes for Members . . . . .		42	8	6			
188		Plans of Showyard . . . . .		9	9	0			
236		Implement Catalogues, 150 <i>l.</i> 11 <i>s.</i> 6 <i>d.</i> ; Bound Copies, 30 <i>l.</i> 2 <i>s.</i> 0 <i>d.</i> . . . . .		190	13	6			
18		Stock Catalogue, 209 <i>l.</i> 12 <i>s.</i> 0 <i>d.</i> ; Bound Copies, 23 <i>l.</i> 1 <i>s.</i> 11 <i>d.</i> . . . . .		232	13	11			
41		Carriage of Catalogues to Show-yard . . . . .		18	1	6			
		Printing of Awards . . . . .		57	0	10			
							895	14	1
		<b>ADVERTISING, BILL POSTING, AND PLACARDING:—</b>							
175		Advertising in Newspapers . . . . .		108	10	0			
559		Advertising Show by Posters and Placards . . . . .		402	0	0			
100		Printing of Posters and Placards . . . . .		117	17	6			
							628	7	6
		<b>POSTAGE, CARRIAGE, AND STATIONERY:—</b>							
127		General Postage, &c., 70 <i>l.</i> 4 <i>s.</i> 4 <i>d.</i> ; Postage of Tickets to } Members, 36 <i>l.</i> 16 <i>s.</i> 7 <i>d.</i> . . . . .		107	0	1			
		Stamp on Agreement with Corporation of Plymouth . . . . .		3	0	0			
							110	0	11
4,658		<b>AMOUNT OF PRIZES AWARDED</b> (for details see page xx) . . . . .					4,485	6	0
		<b>COST OF FORAGE FOR LIVE STOCK:—</b>							
880	{	Hay, 154 <i>l.</i> 0 <i>s.</i> 6 <i>d.</i> ; Straw, 185 <i>l.</i> 11 <i>s.</i> 10 <i>d.</i> ; Green Food, } 249 <i>l.</i> 3 <i>s.</i> ; Expenses, 11 <i>l.</i> 5 <i>s.</i> 2 <i>d.</i> . . . . .					600	0	6
11,683		Carried forward . . . . .					12,071	11	0

Nottingham, 1888.			£ s. d.	£ s. d.
8,060		Brought forward . . . . .		8,905 19 6
<b>ADMISSIONS TO SHOWYARD:—</b>				
90		Saturday, June 21, @ 2s. 6d. . . . .	22 5 9	
418		Monday, June 23, @ 5s. . . . .	308 10 6	
1,388		Tuesday, June 24, @ 2s. 6d. . . . .	1,252 13 9	
1,131		Wednesday, June 25, @ 1s. . . . .	1,970 12 11	
4,418		Thursday, June 26, @ 1s. . . . .	1,621 12 6	
1,824		Friday June 27, @ 1s. . . . .	702 4 0	
9,269				5,877 19 5
507		Season Tickets, @ 10s. 6d. . . . .		138 7 6
<b>ENTRANCES TO HORSE RING:—</b>				
31		Monday, June 23, at 2s. . . . .	33 14 0	
155		Tuesday, June 24, at 2s. . . . .	198 1 6	
61		Wednesday, June 25, @ 1s. . . . .	128 1 0	
154		Thursday, June 26, @ 1s. . . . .	100 11 0	
96		Friday, June 27, @ 1s. . . . .	41 8 0	
				501 15 6
<b>DAIRY:—</b>				
33		Receipts at Stand at Dairy . . . . .	33 9 6	
47		Sales of Produce at Dairy . . . . .	30 13 8	
				64 3 2
<b>CIDER TRIALS:—</b>				
		Admission of non-members to Trial Yard . . . . .		3 6 0
584		<b>SALE OF CATALOGUES, net proceeds . . . . .</b>		362 17 10

**PRIZES AWARDED:—**

The total amount of PRIZES given was distributed as follows:—

Horses, 1,345 <i>l.</i> ; Cattle, 1,651 <i>l.</i> . . . . .	2,996 0 0
Sheep, 1,235 <i>l.</i> ; Pigs, 375 <i>l.</i> . . . . .	1,610 0 0
Poultry, 257 <i>l.</i> . . . . .	257 0 0
Wool, 16 <i>l.</i> ; Cheese, 126 <i>l.</i> ; Butter, 124 <i>l.</i> . . . . .	266 0 0
Cider and Perry, 35 <i>l.</i> ; Jams and Fruits, 15 <i>l.</i> . . . . .	50 0 0
Butter-making, 29 <i>l.</i> ; Horse-shoeing, 42 <i>l.</i> . . . . .	71 0 0
Implements, 170 <i>l.</i> ; Dairy Appliances, 5 <i>l.</i> . . . . .	175 0 0
Contribution to Bee Department . . . . .	40 0 0
Silver Medals . . . . .	7 6 0
	5,472 6 0
Less:—	
Prizes offered by Local Committee . . . . .	£461
" " Devon County Agri- . . . . .	291
" cultural Association . . . . .	235
Prizes offered by Various Societies . . . . .	
	967 0 0
	4,485 6 0

4,229

Debit Balance, carried to Balance Sheet

2,197 7

18,077

£16,051 16



		£ s. d.	£ s. d.
Nottingham, 1888.			
11,683	Brought forward . . . . .		12,071 11 0
<b>JUDGES' FEES AND EXPENSES:—</b>			
	Judges of Implements, 117l. 8s. 6d.; Ditto for Lodgings, 25l. . . . .	142 8 6	
559	Judges of Horses, 160l. 10s. 2d.; Cattle, 140l. 6s. 7d.; Sheep, 159l. 6s. 2d.; Pigs, 47l. 11s.; Poultry, 28l. 16s.; Wool, 6l.; Cheese, 17l. 19s.; Butter and Butter making, 27l.; Ditto for Lodgings, 5l.; Cider and Perry, 6l. 5s.; Jams and Preserved Fruits, 8l. 6s. 6d.; Horse-shoeing, 27l.; Ditto for Lodgings, 10l. . . . .	644 0 5	
20	Badges for Judges and other Officials . . . . .	19 13 9	
31	Rosettes . . . . .	40 15 10	
			846 18 6
<b>EXPENSES OF ADMINISTRATION:—</b>			
	<i>Stewards:—</i> Lodgings, 82l. 11s.; Housekeeping Expenses, 177l. 14s.; Personal and Railway Expenses, 89l. 7s. 5d. . . . .	349 12 5	
	<i>Assistant Stewards:—</i> Honoraria, 52l. 10s.; Railway Expenses, 37l. 12s.; Lodgings, 38l. 6s. 6d. . . . .	128 8 6	
603	<i>Secretary and Official Staff:—</i> Houses, 36l. 16s.; Secretary's Expenses, 13l. 15s. 6d.; Maintenance of Clerks, 36l. 15s.; Travelling Expenses, 15l. 6s. 7d. . . . .	102 13 1	
	<i>Finance Office:—</i> Superintendent of Turnstiles, 17l. 2s.; Money Changer, 10l. 10s.; Money Takers, 55l. 13s.; Bankers' Clerks, 16l. 16s. . . . .	100 1 0	
	<i>Awards Office:—</i> Superintendent, 15l.; Clerks, 30l. 6s. 8d.; Award Boys, 15l. 1s. 6d. . . . .	60 8 2	
			741 3 2
	<i>General Management:—</i>		
	Superintendent of Yard . . . . .	34 8 4	
705	Foremen and Assistant Foremen . . . . .	121 6 4	
	Yardmen, Grooms, and Foddermen . . . . .	277 13 7	
	Door and Gate Keepers . . . . .	59 9 4	
	Carriage Hire, 73l. 17s.; Horse Hire, 74l. 9s. . . . .	148 6 0	
			641 3 7
74	<i>Veterinary Department:—</i> Veterinary Inspectors, 57l. 5s.; Ditto for Lodgings, 10l.; Veterinary Assistants, 16l. 8s. 2d.; Yardmen, 1l. 10s.; Utensils, 18s. . . . .	86 1 2	
230	<i>Engineering Department:—</i> Consulting Engineers and Assistants, 249l. 8s. 1d.; Ditto for Lodgings, 23l. 18s. 6d.; Ditto for Cider Trials, 19l. 9s. 2d.; Carriage, 30l. 11s. 4d.; Repairs and Maintenance of Machinery, 122l. 0s. 2d. . . . .	445 7 3	
505	<i>Police:—</i> Metropolitan Police, 517l. 1s. 2d.; Orderlies, 2l. . . . .	519 1 2	
			1,050 9 7
104	<i>Dairy:—</i> Milk, 82l. 3s. 4d.; Ice, 12l. 10s. 0d.; Dairy Staff, 59l. 8s. 6d.; Carriage, 32l. 15s. 2d.; Utensils, 15l. 4s. 0d. . . . .	202 1 0	
9	Expenses of Analysing Milk of Dairy Cows . . . . .	11 15 11	
			213 16 11
9	<i>Poultry:—</i> Penning, Attendant and Food, 12l. 1s. 2d.; Dead Poultry, 8l. 11s. 6d.; Prize Cards, 5l. 15s. . . . .	26 7 8	
51	<i>Horse Shoeing:—</i> Hire of Forges, 5l.; Nails, Coals, &c., 3l. 17s. 1d.; Gratuities, 10s. . . . .	9 7 1	
<b>GENERAL SHOW-YARD EXPENSES:—</b>			
	Hire of Furniture, 13l. 4s. 0d.; Hire of Chairs, 29l. 4s. 0d.; Hire of Harmonium, 1l. 1s. 0d. . . . .	43 9 0	
178	Tan, 23l. 16s. 4d.; Disinfectants, 19s.; Telegraph, 12l. 16s. 8d.; Newspapers, 19s. 4d. . . . .	38 11 4	
	Band of Royal Marines . . . . .	93 6 8	
	St. John's Ambulance Association . . . . .	17 17 0	
	Miscellaneous Payments:—Secretary, 17l. 6s. 7d.; Surveyor, 5l. 2s. 9d. . . . .	22 9 4	
			215 13 4
<b>TRIALS OF ENGINES, GRIST MILLS AND DISINTEGRATORS</b> (Classes 1 to 3):—			
	Wages to Workmen . . . . .	54 10 5	
	Laying Gas Main . . . . .	9 0 0	
	Bricks, Ironmongery, Coal . . . . .	31 6 4	
	Materials for Trials of Grist Mills and Disintegrators . . . . .	81 16 4	
	Cost of Analysing Coal . . . . .	10 10 0	
	Carriage and Petty Payments . . . . .	1 0 8	
			188 3 9
<b>TRIALS OF CIDER-MAKING PLANT (Class 4):—</b>			
	Hire of Ground, 5l.; Erection of Shed, 14l. 15s.; Travelling and other Expenses, 8l. 1s. 1d.; Apples, 9l. 2s. 8d.; Carriage, 3l. 17s. 8d.; Miscellaneous Expenses of Trials, 5l. 2s. 5d.; Advertising, 1l. 2s. 7d. . . . .	47 1 5	
14,768			£16,051 16 0

Examined, audited, and found correct, this 17th day of November, 1890.

FRANCIS SHERBORN, }  
A. H. JOHNSON. } Auditors on behalf of the Society.

TABLE SHOWING THE NUMBER OF GOVERNORS AND MEMBERS  
IN EACH YEAR FROM THE ESTABLISHMENT OF THE SOCIETY.

Year ending with Show of	President of the Year	Governors		Members			Total
		Life	Annual	Life	Annual	Honorary	
1839	3rd Earl Spencer . . . . .	—	—	—	—	—	1,100
1840	5th Duke of Richmond . . . . .	86	189	146	2,434	5	2,860
1841	Mr. Philip Pusey . . . . .	91	219	231	4,047	7	4,595
1842	Mr. Henry Handley . . . . .	101	211	328	5,194	15	5,849
1843	Earl of Hardwicke . . . . .	94	209	429	6,155	15	6,902 <sup>1</sup>
1844	3rd Earl Spencer . . . . .	95	214	442	6,161	15	6,927
1845	Duke of Richmond . . . . .	94	198	527	5,899	15	6,733
1846	Lord Portman . . . . .	92	201	554	6,105	19	6,971
1847	Earl of Egmont . . . . .	91	195	607	5,478	20	6,331
1848	Earl of Yarborough . . . . .	93	186	648	5,387	21	6,335
1849	Earl of Chichester . . . . .	89	178	582	4,643	20	5,512
1850	Marquis of Downshire . . . . .	90	169	627	4,356	19	5,261
1851	5th Duke of Richmond . . . . .	91	162	674	4,175	19	5,121
1852	Earl of Ducie . . . . .	93	156	711	4,002	19	4,981
1853	Lord Ashburton . . . . .	90	147	739	3,928	19	4,923
1854	Mr. Philip Pusey . . . . .	88	146	771	4,152	20	5,177
1855	Mr. William Miles, M.P. . . . .	89	141	795	3,838	19	4,882
1856	Lord Portman . . . . .	85	139	839	3,896	20	4,979
1857	Mr. E. Denison, M.P. . . . .	83	137	896	3,933	19	5,068
1858	Earl Berners . . . . .	81	133	904	4,010	18	5,146
1859	Duke of Marlborough . . . . .	78	130	927	4,008	18	5,161
1860	Lord Walsingham . . . . .	72	119	927	4,017	18	5,183
1861	Earl of Powis . . . . .	84	90	1,113	3,328	18	4,633
1862	{ H.R.H. Prince Consort . . . . . Lord Portman . . . . . }	83	97	1,151	3,475	17	4,823
1863	Viscount Eversley . . . . .	80	88	1,263	3,735	17	5,183
1864	Lord Feversham . . . . .	78	45	1,343	4,013	17	5,496
1865	Sir E. C. Kerrison, Bt., M.P. . . . .	79	81	1,386	4,190	16	5,752
1866	Lord Tredegar . . . . .	79	84	1,395	4,049	15	5,622
1867	Mr. H. S. Thompson . . . . .	77	82	1,388	3,903	15	5,465
1868	6th Duke of Richmond . . . . .	75	74	1,409	3,888	15	5,461
1869	H.R.H. Prince of Wales . . . . .	75	73	1,417	3,864	17	5,443
1870	Duke of Devonshire . . . . .	74	74	1,511	3,764	15	5,438
1871	Lord Vernon . . . . .	72	74	1,589	3,896	17	5,648
1872	Sir W. W. Wynn, Bt., M.P. . . . .	71	73	1,655	3,953	14	5,766
1873	Earl Cathcart . . . . .	74	62	1,832	3,936	12	5,916
1874	Mr. Edward Holand . . . . .	76	58	1,944	3,756	12	5,846
1875	Viscount Bridport . . . . .	79	79	2,058	3,918	11	6,145
1876	Lord Chesham . . . . .	83	78	2,164	4,013	11	6,349
1877	Lord Skelmersdale . . . . .	81	76	2,239	4,073	17	6,486
1878	Col. Kingscote, C.B., M.P. . . . .	81	72	2,328	4,130	26	6,637
1879	H.R.H. Prince of Wales . . . . .	81	72	2,453	4,700	26	7,332
1880	5th Duke of Bedford . . . . .	83	70	2,673	5,083	20	7,929
1881	Mr. William Wells . . . . .	85	69	2,765	5,041	19	7,979
1882	Mr. John Dent Dent . . . . .	82	71	2,849	5,059	19	8,080
1883	Duke of Richmond & Gordon . . . . .	78	71	2,979	4,952	19	8,099
1884	Sir Brandreth Gibbs . . . . .	72	72	3,203	5,408	21	8,776
1885	Sir M. Lopes, Bt., M.P. . . . .	71	69	3,356	5,619	20	9,135
1886	H.R.H. Prince of Wales . . . . .	70	61	3,414	5,569	20	9,134
1887	Lord Ezereton of Tatton . . . . .	71	64	3,440	5,387	20	8,982
1888	Sir M. W. Ridley, Bt., M.P. . . . .	66	56	3,521	5,225	16	8,884
1889	HER MAJESTY THE QUEEN . . . . .	73	58	3,567	7,153	15	10,866
1890	Lord Moreton . . . . .	122	58	3,846	6,941	17	10,934
1890 (Dec.)	Earl of Ravensworth . . . . .	116	64	3,799	6,926	19	10,924

<sup>1</sup> The figures for 1843 are taken from the December report, after the removal of the names of members who had discontinued their subscriptions; but it was reported in the previous May that 1,436 had been elected during the preceding twelve months, bringing the then nominal total to 7,285. In all other cases, from 1840 to 1890, the figures are from the reports of the Council to the anniversary meeting on May 22. It should, however, be observed that the totals were occasionally affected by the necessary revision of the list.

# ROYAL AGRICULTURAL SOCIETY OF ENGLAND.

## Proceedings of the Council.

WEDNESDAY, FEBRUARY 4, 1891.

THE EARL OF RAVENSWORTH (PRESIDENT) IN THE CHAIR.

### Present:—

*Trustees.*—H.R.H. the Prince of Wales, K.G., Earl Cathcart, Mr. John Dent Dent, Col. Sir Nigel Kingscote, K.C.B., Sir A. K. Macdonald, Bart., Earl of Powis, the Duke of Richmond and Gordon, K.G.

*Vice-Presidents.*—H.R.H. Prince Christian, K.G., Mr. Walter Gilbey, Earl of Lathom, Lord Moreton, Sir John Thorold, Bart., Mr. C. Whitehead.

*Other Members of Council.*—Mr. G. M. Allender, Mr. J. H. Arkwright, Mr. Alfred Ashworth, Mr. Joseph Beach, Mr. J. Bowen-Jones, Mr. J. A. Caird, Mr. Chandos-Pole-Gell, Mr. Charles Clay, Earl of Coventry, Mr. Percy E. Crutchley, Mr. Alfred Darby, Mr. C. De L. F. De Laune, Viscount Emlyn, Mr. William Frankish, Mr. R. Neville Grenville, Mr. James Hornsby, Mr. C. S. Mainwaring, Mr. J. Martin, Mr. T. H. Miller, Mr. P. A. Muntz, M.P., Hon. Cecil T. Parker, Mr. Albert Pell, Mr. Daniel Pidgeon, Mr. J. E. Ransome, Mr. J. Rawlence, Mr. S. Rowlandson, Mr. G. H. Sanday, Mr. Alfred J. Smith, Mr. Henry Smith, Sir Joseph Spearman, Bart., the Marquis of Stafford, Mr. R. Stratton, Mr. Martin J. Sutton, Mr. Garrett Taylor, Mr. J. P. Terry, Mr. R. A. Warren, Mr. E. V. Wheeler, Mr. C. W. Wilson, Sir Jacob Wilson.

Professor Brown, C.B., Mr. E. W. Voelcker.

*Officers.*—Mr. Ernest Clarke, Secretary and Editor; Dr. J. Augustus

Voelcker, Consulting Chemist; Mr. Wilson Bennison, Surveyor.

The following representatives of the Doncaster Local Committee were also present:—Mr. Joseph Firth Clark, Mr. F. Bacon Frank, Mr. John White, Mr. G. T. Wood, Mr. G. B. C. Yarborough, and Mr. George Chafer (Secretary of the Local Committee).

### Minutes of Special Council of December 18, 1890.

The SECRETARY having read the minutes of the last ordinary meeting of the Council held on December 10, and also of the Special Council (convened by requisition) held on December 18,

The Hon. CECIL T. PARKER said he must enter a protest against the action taken at the Special Council in ordering the prizes for two-shear rams, which had been struck out at the last ordinary meeting of the Council, to be restored to the prize sheet, and in issuing the prize sheet with those classes included. He contended that they had exceeded their powers in doing this, as under Bye-law 27 all decisions at a Special Council were subject to confirmation or abrogation at the next ordinary meeting.

The Duke of RICHMOND and GORDON agreed that the course adopted was not one that should be regarded as a precedent, but maintained that the circumstances were exceptional, the prizes in question—which had been given by the Society

for a great length of time—having been struck out of the prize sheet by the Stock Prizes Committee at their December meeting, without any notice whatever to those interested in the breeds affected.

Viscount EMLYN and Mr. DENT supported Mr. Parker's protest; but Mr. BOWEN-JONES and Sir NIGEL KINGSCOTE endorsed the views of the Duke of Richmond and Gordon.

Earl CATHCART said that in signing the requisition for the Special Council he had acted ministerially only, as further discussion seemed to be called for, and he was always in favour of the fullest inquiry.

The Duke of RICHMOND and GORDON having replied to some of the points raised in the discussion, the motion for the confirmation of the minutes was put from the Chair and carried *nem. con.*

#### Apologies for Non-Attendance.

The PRESIDENT announced that he had received a letter from the Earl of Feversham, expressing his regret at being unable to be present in consequence of an important meeting of his County Council that day. Lord Egerton of Tatton and Mr. Foster had also written letters of apology for non-attendance: and a communication had been received from Mr. Anthony Hamond expressing his regret that, owing to his absence abroad for several months, he would be unable to attend the next few meetings of the Council.

#### The late Duke of Bedford.

The PRESIDENT said he had now a very painful duty to perform in announcing officially to the Council the death of the Duke of Bedford, one of the Trustees of the Society, and perhaps the most munificent patron it had ever had. He felt sure that in expressing his own personal regrets at the heavy loss which the Society and agriculture generally had sustained by his Grace's death, he was echoing the feelings of every member of the Council, and of every member of the Society. He had had for many years the privilege, the pleasure, the advantage of his Grace's personal friendship. The Duke was a man—

unfortunately in these times too rare—who was seen, but not heard. He was always to be seen in his place; and his place was wherever he thought it his duty to be. He was, perhaps, one of the most regular and punctual attendants in the House of Lords; and whether in the Committee rooms of that House, or in the House itself, his well-known figure and his keen and observant features would long be missed in the place he formerly occupied. But, though sparing in speech, he was readily accessible in council; and he ventured to think that few of those—and there were many—who had consulted him in life had reason to regret it. His Grace's great intellectual powers, his extensive reading, his knowledge of men and affairs, his great affability, his ready kindness and keen wit, rendered his advice immensely valuable, and his companionship most agreeable. But it was in his connection with that Society that they in that room were specially endeared and indebted to his Grace. He had described the Duke as a munificent patron, and he thought that title was well deserved. It was now fourteen years since his Grace handed over to the Society, for the purpose of a model experimental farm, a considerable tract of land at Woburn. Through the generosity of his Grace, the Society had been enabled, for a long course of years, to conduct most important and valuable experiments, and to give the results of them to the country. He ventured to think that the knowledge so obtained had been of extreme interest to the Society itself, and of value to agriculture generally. Very important lessons had been learnt from those experiments, and he would remind them of what the world in general was hardly aware, that his Grace took the deepest interest in their conduct and progress. One of his last letters was to the effect that expense was to be no object, and that he would be willing to assist the experiments in every possible way. The site of the experiments was by no means a favoured spot at first, but by skilful culture and judicious application of manures scientifically applied—operations largely guided by the late Dr. Voelcker—it was turned into

what he might fairly term a beautiful agricultural garden. The Council all felt deeply the loss of a generous patron of the Society, and a large circle of those associated with the Duke in life deplored the decease of a true and valued friend. He was sure it would be the wish of the Council that they should pass a resolution of condolence with the great and historic family of Russell at the death of their chief.

The resolution, proposed by the PRESIDENT, was then put and carried unanimously, and his Lordship undertook to communicate it by personal letter to the present Duke.

### Election of Governors and Members.

The election of the following two Governors and 129 members was then proceeded with:—

#### Governors.

CORBETT, John, M.P., Impney, Droitwich.  
EVANS, John Carbery, Hatley Park, Gamlingay, Cambs.

#### Members.

ANDERTON, H. F., Bolton Royd, Bradford.  
ANDREWS, G., Bendon Villa, Bendon Valley, Wandswoth, S.W.  
APPLEBY, Arthur, Enfield, Acrrington.  
APPLEBY, Edgar, Blackburn.  
ARNOLD, J., Outwood Park, Gt. Packington.  
ARNOLD, L., Old Farm, Gt. Packington.  
ARNOLD, P., Home Farm, Hints, Tamworth.  
ASHWORTH, R., Bromley Cross, Bolton.  
ASHWORTH, T. K., Hatley St. George, Cambs.  
BAINBRIDGE, C., Clarendon, Harrogate.  
BALE, H., Mill Street, Kidderminster.  
BARLOW, T., Misterton, Gainsborough.  
BARNES, W. A., Shirley, Birmingham.  
BEARD, J., Warsop, Mansfield.  
BELLAMY, E. F., The Moat, Newent, Glos.  
BENNETT, H. T., Keyfield House, Swinefleet, Goole.  
BERRY, A., Dodington Hall, Bridgwater.  
BIRD, G. W., South Molton, Devon.  
BISHOP, W., Tetstill H., Clebury Mortimer.  
BLIGH, Major F. C., 33 Roland Gardens, S.W.  
BLITZ, R., 39 Mincing Lane, E.C.  
BRADLEY, Joseph, Ebberston, York.  
BROMLEY, Henry, Ashwell, Oakham.  
BROWN, Joseph, Gainsboro' Hill, Walsall.  
BUTLER, J. R., Churchill, Kidderminster.  
CARTWRIGHT, Captain H. A., Eydon Hall, Northants.  
CATTELL, T., Erdington, Birmingham.  
COBBOLD, C. H., Rosehill, Dodworth, York.  
CODDINGTON, F. H., East Park Road, Blackburn.  
COOPER, D., Warren Tower, Newmarket.  
COULMAN, W., Eastoft Hall, Goole.  
COULTON, J., Dunnimere Farm, Harlston, Staffs.  
CROSLAND, R., Canford Estate Office, Dorset.  
D'ARCY, W. K., Stanmore Hall, Middlesex.  
DIVES, W. A., Stone Crouch, Hawkhurst.  
DOUTHAITH, W. C., Manor Farm, Fawler, Charlbury.

DUTE, Kedarnantte, Zamindar of Dhobetal, Tangore Islands, Bengal, India.  
DYSON, Arthur E., The Hollies, Timperley.  
EDWARDS, Thomas, Aintree, Liverpool.  
EGGINGTON, Oliver, Earley Schools, Reading.  
ERSWELL, Alfred, Barley, Royston, Herts.  
EVANS, A. L., Hatley St. George, Cambs.  
FARRAN, S., North Street House, Taunton.  
FITZGERALD, Sir M., Bt., Severals Ho., Newmarket.  
FOSTER, F. D., The Hall, Thorne, Yorks.  
FREIR, W. F., Imperial Buildings, Ludgate Circus, E.C.  
FRY, F. G., King's Caple Ct., Ross, Herefordshire.  
GIBBONS, J., 16 Water Street, Liverpool.  
GOODY, J., Darfield, Barnsley.  
GREEN, T., The Bank, Pool Quay, Welshpool.  
GREEN, Wm. Henry, Kersal Hall, Higher Broughton.  
HAINE, F., Over Farm, Gloucester.  
HAIRSINE, J., Metham, Howden, Yorks.  
HANSON, J. F., 15 Nether Hall Road, Doncaster.  
HARRISON, C., Broad Heath, Presteign.  
HEBBLETHWAITE, L., Whitefriar Gate, Hull.  
HENGLER, W. B., Kent's Green Ho., Taynton.  
HILL, H., Old Rock, Dymock, Glos.  
HINCKLEY, F., Barnhurst Farm, Wolverhampton.  
HUDDLESTON, J. E., Hill Wood, Tenbury.  
HUMPHREY, W. J., Acklam, Middlesbrough.  
IANSON, Major J., Howe, Thirsk.  
INGHAM, R. W., Sugwas Court, Hereford.  
JACKSON, J., Elton Wold, Elton, York.  
JOBLING, T. H., Stamford, Alnwick.  
JOWETT, J. A., Manningham, Bradford.  
KENNINS, W., J.P., Killeen, Portlaurington.  
KINSEY, J., Over Peover, Knutsford.  
KNIGHT, G. B., Pirton, Worcester.  
LAKIN, A. O., Marbury, Whitechurch, Salop.  
LARDNER, H. H., Freetown, Sierra Leone.  
LEA, E. E., Netherton, Bewdley.  
LUCAS, E., Home Farm, Baginton, Coventry.  
MAKINSON, G., 62 Market Place, Wigan.  
MATTHEWSON, J., E. Moneylaws, Cornhill-on-Tweed.  
MAYALL, G., Stretton Vicarage, Ledbury.  
MEESON, A. J., Rawtheth, Essex.  
MICKLETHWAIT, R. K., Ardsley House, Barnsley.  
MITCHELL, J., Bolton Hall, Rotherham.  
MUNBY, E. C., The Hermitage, Oswaldkirk, York.  
MYERS, W. H., J.P., Swanmore Ho., Bishop's Waltham.  
NASH, R. S., The Noak, Martley, Worcester.  
NELLIST, J., The Crundalls, Bewdley.  
NEWMAN, Rev. W. F., Hockworthy, Wellington, Somerset.  
NICHOLSON, J. E., Manor Ho., Lancaster, Durham.  
NIELD, J., Woodhouse Farm, Solihull, Birmingham.  
NOCK, H. T., Oldbury, near Birmingham.  
OLDFIELD, F. R., Sawcliffe, Appleby, Doncaster.  
OLIVER, M. J., Treneer, St. Teedy, Bodmin.  
OPPENHEIM, H., Wytham Abbey, Oxford.  
OTHER, T. J., Howgrave, Ripon.  
PARKIN, Alfred, Doncaster.  
PARTINGTON, E. S., Crumpsall Green, Cheetnam Hill, Manchester.  
PEARSON, W. J., Stockton Court, Tenbury.  
PICKARD, J., High Thorsby, Leyburn, Yorks.  
PILKINGTON, L., Cavens, Dumfries, N.B.  
PLACE, J. M., Eriswell, Brandon.  
POCKLINGTON, Col. F., Chelsworth, Suffolk.  
RAINERI, Prof. Dr. John, Piacenza, Italy.

REDMAN, J. H...The Farm, Kidmore Grange, Caversham, Oxon.  
 ROBINSON, A. S. F...Wantage, Berks.  
 ROGER, Hugh...42 Poultry, E.C.  
 RUSSELL, Gen. Lord Alexander G...Ewhurst Park, Basingstoke.  
 RUSSELL, Thomas...20 Bucklersbury, E.C.  
 RYLAND, C. A. S...Barford Hill, Warwick.  
 RYLANDS, Dan...Stainfoot, Barnsley.  
 SAMPLE, C. H...Matfen, Newcastle-on-Tyne.  
 SAMUELSON, E...Anlaby, West Kirby, Cheshire.  
 SAYORY, Right Hon. Joseph, Lord Mayor of London...Buckhurst Park, Ascot, Berks.  
 SHAW, J...Halder Road, Birmingham.  
 SMITHSON, R. H. D...Wiseton Grange, Bawtry, Notts.  
 STORY, Pryce E...Coppy, Denbigh.  
 STURGIS, T...45 Broadway, New York City, U.S.A.  
 STYAN, W...Moor House, Leyburn, Yorks.  
 TAYLOR, E. F...Bracon Ash, New Barnet.  
 TENNANT, Major J. T...69 Belgrave Road, S.W.  
 THOMPSON, G...Wroxhall, Warwick.  
 THOMPSON, J...Beardwood Cliff, Blackburn.  
 THOMPSON, R...Whalley, Lancs.  
 VERNON, Hon. and Rev. C. J...Grafton Underwood, Kettering.  
 VOELCKER, E. W...39 Argyll Road, Kensington, W.  
 WAINWRIGHT, J...Over Peover, Knutsford.  
 WALKLEY, H...Berkley House, Selhurst, S.E.  
 WELLS, H. C., J.P...Broomfield Lodge, Chelmsford.  
 WHITTING, F...King's College, Cambridge.  
 WILKINSON, F. E...Scrooby, Bawtry, Notts.  
 WILSON, P. H...Hadleigh, Suffolk.  
 WOODFORDE, F. C...Grammar School, Market Drayton.  
 WRENNALL, W...9 Harrington St., Liverpool.

### Country Meeting of 1892.

The SECRETARY reported that the Committee appointed at the meeting of Council in November last to inspect the sites and other accommodation offered by the local authorities of Warwick and Gloucester respectively for the Society's Country Meeting next year had made their inspection last week, and the customary formal answers to the Society's queries had been signed by the Mayor and Town Clerk of each place. Deputations were now in waiting from both districts to support their applications. The Speaker of the House of Commons had called at the Society's offices on Monday last in order to express his regret that his Parliamentary duties would prevent his attending on that day, as he should otherwise have made a point of doing, to support the invitation given by the local authorities of Warwick.

### *Invitation from Warwick.*

The deputation from Warwick, which was first received, consisted of

Lord Leigh (Lord Lieutenant of the County), Lord Brooke, M.P., Mr. P. Albert Muntz, M.P., the Mayor and Town Clerk of Warwick, Mr. T. H. G. Newton, Mr. Margetts, and Mr. Fredk. H. Moore (Local Secretary).

Lord LEIGH, in introducing the deputation, said they hoped most sincerely that the Council would select the town of Warwick for their Country Meeting of 1892. It was now thirty-two years ago since the Royal Agricultural Society visited their town, in 1859, when the Show was one of the best that, up to that time, had ever been held. He had had then the honour of performing the same function which was his pleasant duty that day, viz., of introducing the deputation. The railway accommodation of the district was admirable, and Warwick was in the midst of a population which, within a radius of forty miles, numbered a million of people. He believed the sites which they were prepared to offer could not be surpassed in any county of England. They had the magnificent park of Lord Warwick, which was acknowledged to be one of the finest castles and one of the grandest parks in the kingdom, and they had also the racecourse, on which the Society held their Show in 1859, and which was considered a very good site indeed. There was an ample supply of water, and, indeed, he did not know that there were any of the Society's requirements with which they could not comply. He earnestly hoped that their country town would be selected for the Society's Country Meeting of 1892.

The Mayor of WARWICK (Mr. J. W. MANN) said that Lord Leigh had mentioned the fact that Warwick was very central: it was, in fact, situated in the centre of England. It was accessible from almost every point, being served by the Great Western Railway by its main line from London to Birmingham, and also by the London and North-Western Railway. Leamington and Warwick for this purpose formed practically one borough. They had four stations, and the accommodation for traffic was ample. The interest of Warwick and its vicinity was very great, and Warwick Castle was a

source of great attraction. The Castle Park, he ventured to say, was a site that could not be beaten. His colleague, the Mayor of Leamington, was unfortunately too unwell to attend that day, or he would have been present to have supported him in a cordial invitation to the Society to hold its next year's Meeting in their district.

Mr. T. H. G. NEWTON would like to give two more reasons why Warwick should claim the honour of the Country Meeting of 1892. He found on examination that of the counties in the F district one Show had been held in Gloucestershire, two in Shropshire, two in Warwickshire, one in Worcestershire, one in Staffordshire, and one in South Wales. The financial results were most favourable for Warwickshire. The total surplus for their county was 4,800*l.*, whereas at Cardiff (1872) there was a deficit of 600*l.*, at Worcester (1863) 1,200*l.*, and for Gloucestershire and Staffordshire deficits of about 2,000*l.* each. The last five Meetings of the Society had resulted on balance in a deficit of some 6,000*l.*, so that 1892 did not seem an occasion on which the Country Meeting should be held anywhere but in a county in which they might hope to get a surplus. Although he was perfectly willing to admit that at Doncaster they had a chance of securing a surplus, yet they wanted two good chances, in order that they might be sure of getting a surplus between them. It was very obvious that one necessary element of success in a country show was the population, which had already been adverted to. He found that in the area of forty miles from Warwick there were no less than 422 railway stations; so that this large population had ample facilities for attending the Show.

The PRESIDENT having thanked Lord Leigh, Lord Brooke, and the other gentlemen for their attendance and explanations,

The deputation retired.

#### *Invitation from Gloucester.*

The Earl of COVENTRY introduced the following deputation from the city and neighbourhood of Gloucester, inviting the Society to hold

its Show at Gloucester in the year 1892:—Lord Apsley, Lord Fitzhardinge, Lord Moreton, Lord Sudeley, Lord Tredegar, Sir John E. Dorington, Bart., M.P., Sir Hussey Vivian, Bart., M.P., Sir Nigel Kingscote, K.C.B., Mr. B. St. John Ackers, Mr. Wilfrid Cripps, C.B., Mr. Fuller, M.P. (Wiltshire), Mr. Granville E. Lloyd-Baker, Mr. Alfred Thomas, M.P. (Cardiff), Mr. T. Robinson, M.P. (City of Gloucester), the Mayor of Gloucester (Mr. J. J. Seekings), the Mayor of Cheltenham (Colonel Thoyts), and Mr. G. S. Blakeway (Town Clerk).

LORD FITZHARDINGE said that very briefly he should ask them to favour Gloucester by holding the Show of 1892 in their city, for the simple reason that they had not been honoured with a visit from the Society since 1853, whereas their rival and neighbour had been visited by the Society in 1859. Since 1853 the population of South Wales, which was included in their district, had enormously increased, and he felt sure that if His Royal Highness the Prince of Wales would only honour them with his presence, the Welshmen would turn out by thousands to do him homage. That was the great reason why Gloucester should have the preference.

LORD SUDELEY said it was not necessary for him to say more than that they were in the centre of a very large district. They had the most ample railway accommodation. They had two of the largest railway companies running through their city, and there was no doubt that they would be able to bring a very large population from the West of England, from Wales, and from the North. In Gloucester they had been very long deprived of the presence of the "Royal" Society, and he thought that a visit from them would do an enormous amount of good to their agricultural population. Moreover, they felt quite sure that if the "Royal" would honour them with a visit they would be able to make the Show pay.

The Mayor of GLOUCESTER (Mr. J. J. Seekings) said he had great pleasure in appearing that day to present to them a very warm invitation from the ancient and historic city of Gloucester, from the town of Cheltenham,

and from the county of Gloucester generally, to hold the Show of 1892 in their city. They had a large and satisfactory subscription list—already amounting to 4,500*l.*—to which additions were daily being made. There would be no difficulty in raising the funds required by the Society, or in complying with their requirements in other respects. The point upon which they laid great stress was the geographical position of Gloucester, which was situated at a junction of two important lines of railway. Gloucester had in itself close upon 45,000 inhabitants, and Cheltenham, which was only six miles off, had an almost equal population. Bristol with its 200,000 inhabitants, was close at hand, and within what he might call a half-crown railway fare was a population of close upon a million. They felt they had special advantages in respect to railway conveniences, as they had two passenger stations in Gloucester, and four goods stations, as well as a siding within a few yards of the proposed site. He thought the Committee of Inspection who visited Gloucester the other day would agree that the site they offered was a very eligible one. It was composed of large fields, was pleasantly situated, and was easily reached from the city. There were main roads leading to it, and attractive routes both from the city and railway stations. Gloucester, besides possessing the interesting traditions of an old cathedral city, had important industries, including flour-mills fitted up on the most modern principles. Many different systems of farming could be studied in the district, and they had, besides, important agricultural institutions like Cirencester College. There was ample hotel and lodging accommodation in the two towns, particularly at Cheltenham, which had been described as a town of hotels and lodging-houses, and as the "Garden Town of England." He claimed that these were definite points of superiority over any other offer received by the Society. A comparison of the dates when the last Show was held at Gloucester and at Warwick showed that the Society had not paid a visit to Gloucester since 1853, but had been to Warwick in 1859. South Wales, with its very

large population, was far more accessible for Gloucester than for Warwick, which could only be reached by changing. If the Council honoured them with a visit next year, they might be assured of a hearty welcome from the district, on whose behalf he had the privilege and pleasure of presenting the invitation to the Society to hold its Country Meeting of 1892 in the city of Gloucester.

Sir HUSSEY VIVIAN asked leave to say a few words on behalf of South Wales in support of the invitation. Their population was a very large one. In Glamorganshire alone there were 600,000 inhabitants, and the population took a deep interest in agriculture, which was manifested by their large attendance at the Shows of local societies. They would be sure to largely avail themselves of the advantage of attending the Royal Agricultural Society's Show if held at Gloucester, as that city was within easy distance of the great centres of population in South Wales. He did not think, however, that the population of South Wales would go in any numbers so far as Warwick. He therefore begged very earnestly to urge the importance of holding the Show of 1892 at Gloucester rather than at Warwick.

Lord TREDEGAR said that one of the great objects of the Society was the promotion of agricultural interests; and as they had a great deal to learn with regard to farming in South Wales, he thought the Society would be doing more good and would be acting up to its principles in deciding to go to Gloucester, which was readily accessible to South Wales, rather than to the Midlands, where people were supposed to know everything.

The PRESIDENT thanked the deputation for attending, and said the Council were in the position of having an *embarras des richesses*.

Lord COVENTRY thanked the Council for their courteous reception of the members of the deputation, who then retired.

Mr. MAINWARING having read the report of the Committee of Inspection on the various sites which had been submitted to their inspection at Warwick and Gloucester, the PRESIDENT



declared the question of the choice of a locality for their Meeting of 1892 to be open for discussion.

Mr. MUNTZ, M.P., said that it would not be necessary for him to enter into the merits of the case, as these had been fully explained by the deputation; but in moving that Warwick Castle Park be selected as a site for the Society's Country Meeting of 1892 he did so not so much in the interests of his own county as in the interests of the Society. The Society had had a large number of deficits in the last few years. He ventured to forecast that the result of the Meeting, if held at Warwick, would be a financial success, as there was a very large population concentrated in the immediate vicinity; and, besides, Warwick and its vicinity was a point of great historical interest to the population throughout the whole kingdom. He had great pleasure, therefore, in moving—

That the Country Meeting of 1892 be held at Warwick Castle Park, subject to the condition that the usual agreement be entered into with the Society by the Mayor and Corporation at Warwick, such agreement to embody the answers to the Society's printed queries.

The Hon. CECIL T. PARKER seconded the motion.

Lord MORETON moved as an amendment that the Country Meeting of 1892 be held at Gloucester. This was seconded by the Earl of COVENTRY.

After some remarks by Sir NIGEL KINGSCOTE, Viscount EMLYN pointed out that it was a matter worthy of the consideration of the Council, in deciding the question, that the Bath and West of England Society's Meeting of 1892 had been settled to be held in South Wales, at Swansea, which was much closer to Gloucester than to Warwick.

Lord Moreton's amendment having been put to the vote, there appeared six votes for it and thirty-five votes against it. Mr. Muntz's resolution was then put as a substantive motion, and was carried *nem. con.*

The deputation from Warwick having been re-introduced,

The PRESIDENT acquainted them with the Council's decision, saying

that the merits of the respective places had been duly weighed, and the Council had, by an overwhelming majority, decided that their Country Meeting of 1892 should be held in the magnificent park which the Earl of Warwick had so kindly placed at the disposal of the Society.

Lord BROOKE, M.P., said that his father, the Earl of Warwick, naturally took the deepest interest in agriculture, and it would be a proud moment for them when the Society again visited their borough. So far as he himself was concerned, it would give him the greatest pleasure to offer them every hospitality in his power.

Lord LEIGH thanked the Council for their kind reception of the deputation, and for the decision at which they had arrived. They intended to do their utmost to make the Warwick Show a very great success.

The decision of the Council was communicated to the Mayor of Gloucester by letter, signed by the President, expressing the thanks of the Council for the attendance of the deputation from the city and county of Gloucester, and for their kind offer of support in the event of the Show being held in their locality.

The reports of the several Standing Committees were then presented, and adopted, as below:—

#### Finance.

Sir NIGEL KINGSCOTE reported his election as Chairman of the year. The accounts for the month ended December 31, 1890, as certified by the Society's accountants, showed receipts amounting to 1,601*l.* 3*s.* 3*d.*, and expenditure 1,961*l.* 10*s.* 8*d.* The actual balance at the bankers on December 31, 1890, allowing for cheques outstanding, was 1,736*l.* 13*s.* 1*d.* The accounts for the month of January, 1891, showed receipts amounting to 4,300*l.* 14*s.* 3*d.*, and expenditure 367*l.* 13*s.* 6*d.* The balance at the bankers on January 31, allowing for cheques outstanding, was 5,669*l.* 13*s.* 10*d.* Accounts amounting in all to 1,056*l.* 8*s.* were recommended for payment. The quarterly statement of arrears and property at December 31, 1890, was laid upon the table. The Committee recommended that the names of two governors, forty-one life members,

and seventeen annual members who were deceased, forty-three who had resigned, four whose addresses could not be found, and six in arrears, be struck off the register, together with the members who had resigned during 1890 as at the end of that year.

#### **Show of Thoroughbred Stallions.**

On the motion of Sir NIGEL KINGSCOTE, it was unanimously resolved—

That the Secretary be authorised to issue to any candidate for election as a new member, who may make application on or before Saturday, February 28, a ticket of admission to the forthcoming Horse Show at the Royal Agricultural Hall, provided that the usual form of undertaking has been previously signed by the candidate, and that his subscription for the current year has been paid.

Subsequently, the Duke of RICHMOND and GORDON, as Chairman of the Thoroughbred Stallion Committee, reported that ten entries had been received for the three premiums of 200*l.* each, offered by the Society at this Show, for stallions to serve mares during the forthcoming season in the county of York.

#### **House.**

Sir NIGEL KINGSCOTE reported his election as Chairman of the year. Mr. E. S. Rodd, of Chardstock House, Chard, had most kindly presented to the Society a picture of a Devon cow, painted by R. R. Scanlan; and the Committee recommended that the thanks of the Society be given to Mr. Rodd for this gift. They also recommended that in future any member desirous of using the reading-room or library be required to enter his name and address in a book to be provided for that purpose in the entrance hall.

#### **Journal.**

Earl CATHCART reported his election as Chairman of the year. The fourth number of the new series of the Journal had been published on December 31, and issued immediately to members. The Committee presented their recommendations as to the payments for literary contributions to and printing of that number. The new printing agreements authorised

by the Council at their last meeting had been duly executed. Various requests for permission to reproduce illustrations in the Journal had been granted upon the usual conditions. In consequence of the recent severe weather, the inspection of the Yorkshire farms entered for competition had been delayed until the end of January. The Judges had now partly inspected the farms, and would complete their inspection in the course of a few days. The Editor had submitted his preliminary proposals for the contents of the next number of the Journal, which had been discussed and provisionally approved. Various suggestions for papers and notes had been considered, and directions given thereon.

#### **Chemical.**

Viscount EMLYN reported his election as Chairman of the year. Notice of the receipt of a writ in an action against the Society by Mr. James Snowsell, of Cirencester, for alleged libel in connection with the publication of the Chemical Committee's Quarterly Report for July, 1890, had been communicated by the Society's solicitors, and it had been resolved to defend the action.

The Committee had also confirmed and unanimously adopted the following resolution, passed by the Woburn Sub-Committee:

The Woburn Sub-Committee cannot meet without recording their deep sense of the heavy loss which the Society has sustained by the death of the late Duke of Bedford, to whose munificence the establishment of the Woburn Experimental Farm was due, and who had generously borne the whole of the expenses of carrying on the experiments during the last fourteen years.

#### **Return of Dr. J. Augustus Voelcker.**

Viscount EMLYN announced that the Society's Consulting Chemist, Dr. J. Augustus Voelcker, had returned from his mission in India, and was present among them that day. He was sure the Council would welcome Dr. Voelcker back to work, and would be glad to know that the important inquiry which had been entrusted to him by the Government of India had been successfully completed.

The PRESIDENT congratulated Dr. Voelcker upon his safe return home, and hoped that he had derived much benefit from his visit.

#### **Services of Mr. E. W. Voelcker.**

LORD EMLYN then said he was sure that he expressed the feeling of all who had been brought into contact with Mr. E. W. Voelcker as Acting Consulting Chemist in saying that Mr. Voelcker had thrown himself heartily into the work of the Society, and that his tact and ability in the discharge of his duties could not be too highly commended. The Chemical Committee had had under consideration the form which their recognition of Mr. Voelcker's services should take, and on the whole it was thought that the offer of the life membership of the Society would be the most useful as a compliment to Mr. Voelcker. He had great pleasure, therefore, in moving the following resolution:—

The Council cannot allow their connection with Mr. E. W. Voelcker to cease without placing on record their high sense of the very able manner in which he has fulfilled the duties of Acting Consulting Chemist during the past year, and they request his acceptance of the privileges of a life membership of the Society in recognition of their appreciation of these services.

LORD EMLYN's motion having been seconded by Mr. DEST and carried unanimously,

MR. VOELCKER said he could not adequately express to the Council his gratitude for the very high honour that had been conferred upon him by the adoption of the resolution of Lord Emlyn. When he took the charge of the Chemical Department of the Society, he felt a very great responsibility, but, at the same time, a great privilege had been given to him. He was very proud to think that the Council, by their resolution, had shown him that he had done his duty. Without the cordial co-operation of every one with whom he had been brought into contact, he would not have been able to fulfil the duties of the position. He thanked all the members of the Chemical Committee,

and especially Lord Emlyn, for their kind help and assistance on every occasion. In connection with the Woburn Experiments, his especial thanks were due to Mr. Charles Howard for his generous counsel and advice. To Mr. Clarke and to all the officials of the Society he was very greatly indebted. He should always have the greatest pleasure in possessing the life membership of the Society, because it would give him a feeling of permanent connection with the Society, which he should value immensely.

#### **The Woburn Experimental Farm.**

MR. WARREN said he should be glad to be permitted to state that he had received a letter written on behalf of the present Duke of Bedford saying that his Grace was "only too anxious to carry on the Experimental Farm at Crawley as it had been hitherto, if the Royal Agricultural Society would allow him to do so under their kind guidance and advice." Mr. Warren said it was not fully known to the general body of members of the Society, and not even to all the members of the Council, what a large expense this experimental farm involved. The late Duke had generously granted them a sum of from £800 to £1,000 a year for the purposes of the experiments. They would see, therefore, how great was the value of the intimation of the present Duke that he would continue to carry on the farm as hitherto.

The PRESIDENT said that the sincerest thanks of the Council were due to the Duke of Bedford for his munificent offer. He felt sure they would join in a most cordial expression of gratitude for his Grace's generosity in continuing to defray the cost of experiments of so much value alike to the Society and to agriculture generally.]

A resolution in this sense was carried unanimously, and the President undertook to convey it to his Grace.

#### **Seeds and Plant Diseases.**

MR. WHITEHEAD reported his election as Chairman of the year. In accordance with the request of the Committee made at their last meeting, the Consulting Botanist had brought up a recommendation as to the issue

by the Society of diagrams of pasture grasses and clovers. It had been suggested that some diagrams by Bauer, now in the Natural History Department of the British Museum, illustrating the various stages in the growth of the wheat plant, which were made under the direction of Sir Joseph Banks about seventy years ago, should be reproduced by the Society and published with the diagrams of pasture grasses. It was considered that such diagrams would be of great educational value, and would find a ready sale now that the question of agricultural education was receiving so much attention. The Committee recommended, therefore, that the preparation of these diagrams be commenced forthwith. In addition to footnotes on the diagrams, Mr. Carruthers had undertaken to write a pamphlet explanatory of the diagrams for the use of advanced students. The Committee had also under consideration the question of the issue of diagrams showing the nature and causes of diseases affecting the potato.

#### Veterinary.

Sir JOHN THOROLD reported his election as Chairman of the year. Professor Brown had presented the following report, together with the annual report of the Royal Veterinary College, which the Committee recommended for publication in the *Journal* (see page 146). The subject of Pink Eye in Horses had been discussed in reference to a note on this disease by Professor Axe, written for the *Journal*. The Examiners in Practical Cattle Pathology for the diploma of the Royal College of Veterinary Surgeons in 1890 had reported that the following gentlemen, placed in order of merit, had attained the greatest distinction:—(1) J. E. Row, Veterinary Infirmary, Newgate Street, Chester; (2) F. E. Place, 4, Parker's Place, Exmouth. The Committee recommended that the Society's large medal be given in silver to Mr. Row, and in bronze to Mr. Place. They also recommended the appointment of Mr. Lewis P. Rees, of 5, Lammas Street, Carmarthen, as Provincial Veterinary Surgeon for Carmarthen-shire.

#### Professo. Brown's Report.

**PLEURO-PNEUMONIA.**—During the four weeks ended January 24, outbreaks of this disease have been dealt with by the Board of Agriculture in the counties of Durham, Essex, Lancaster, Surrey, York (W.R.), Aberdeen, Ayr, Fife, Forfar, Linlithgow, and Midlothian. By order of the Board fifty cattle affected with pleuro-pneumonia in various stages were slaughtered, as well as 510 other cattle which had been in contact with the diseased animals, or otherwise exposed to infection.

**ANTHRAX.**—Of this disease fifteen fresh outbreaks were reported in the four weeks, in the counties of Bucks, Cumberland, Hants, Hunts, Lincoln (Kesteven), Norfolk, Rutland, Somerset, York (W.R.), Aberdeen, and Dumfries. In these outbreaks thirty animals were attacked, eight diseased animals were killed, fifteen died, and five recovered.

**SWINE-FEVER.**—This disease is again decreasing, and has been so for some weeks. In the four weeks of November the outbreaks reported in Great Britain amounted to 411, or just on 103 per week. In December they fell to 343, or about eighty-six per week, whereas in January they still further declined to 248, or sixty-two per week. In these January outbreaks 1,968 pigs were attacked, 864 diseased pigs were killed, 900 died, 265 recovered, and 412 remained alive when the last published return was made up.

**RABIES.**—There have been six cases of this disease, all of them in dogs, reported in the month; one of these occurred in Hants, two in Kent, and three in York (W.R.).

#### Stock Prizes.

Mr. FRANKISH reported the election of Mr. Sanday as Chairman of the year. An offer by the British Berkshire Society of a champion prize of 10*l.* at Doncaster had been accepted on condition that it should be for the best animal exhibited in classes 171 (Boars farrowed in 1890) and 173 (Breeding Sows).

**Judges' Selection.**

Mr. FRANKISH for Mr. Sanday (Chairman) reported that the Committee had selected a list of Judges of Live Stock, Produce, and Implements, to be invited to act at the Doncaster Meeting in June next on the usual terms.

**Implement.**

Mr. FRANKISH reported his election as Chairman of the year. The Committee presented their recommendations as to the appointment of Judges for the trials of Threshing Machines and Miscellaneous Implements at the Doncaster Meeting, and suggested that in connection with the Meeting for 1892 there should be Trials of Ploughs and Diggers to be worked by horse-power.

**General Doncaster.**

Mr. DENT, in presenting this report, stated that the Committee recommended that the prices of admission on the several days of the Doncaster Meeting be as under:—Saturday, June 20th, 2s. 6d.; Monday, 22nd, 5s.; Tuesday and Wednesday, 2s. 6d. each day; Thursday and Friday, 1s. each day. In view of the small sale of season tickets which had of late taken place in consequence of the granting of free tickets to the subscribers to the local fund, it was not proposed that season tickets be placed on sale at the Doncaster Meeting. Authority had been given for the necessary application to the Home Secretary for the services of a detachment of the Metropolitan Police.

**Showyard Works.**

Mr. CLAY reported the election of Sir Jacob Wilson as Chairman of the year. Applications from the Doncaster Agricultural Society for an office in the Showyard, and from Mr. J. Firth Clark for space for the exhibition of warbled hides, &c., had been granted free of charge. The forms of tenders for refreshments at the Doncaster Meeting had been considered and approved. Offers from various firms of appliances in connection with the Showyard had been considered and accepted.

**Selection.**

Earl CATHCART reported his election as Chairman of the year.

The recommendations of the Committee as to the vacancy on the Council having been read, it was moved by Earl CATHCART, seconded by Mr. ALFRED DARBY, and resolved unanimously:—

That Mr. E. Wilfrid Stanyforth, of Kirk Hammerton Hall, York, be elected a member of Council to fill the vacancy caused by His Royal Highness Prince Christian of Schleswig-Holstein, K.G., having accepted the office of a Vice-President of the Society.

**Education.**

Mr. DENT reported the election of Lord Moreton as Chairman of the year. The Committee had further considered the question of the addition of the subjects of fruit farming, dairying, and forestry to the Society's Senior Examinations, together with a letter on the subject of these examinations from Dr. Dobbie, of the Bangor University College, and a resolution passed by the Agricultural Committee of the Bangor College as to the establishment of Intermediate Scholarships. The Committee did not propose any immediate change in the Society's system of examinations; but they thought it would be well that, when the proposals of the various County Councils as to technical education had taken a more definite shape, a conference should be convened between the Committee and representatives of the various teaching institutions to consider what changes, if any, were desirable in the Society's examinations, in order to fit in with the teaching given for the examinations of other bodies. The subject of the preparation of text-books in agriculture for the use of elementary schools had been discussed, and it had been eventually resolved that a sub-committee, to consist of Lord Moreton (Chairman), Major Craigie, Mr. De Laune, Mr. Pidgeon, Mr. Sutton, and Mr. Whitehead, should be appointed to consider the whole subject and to report to a later meeting. The Committee, having considered a number of communications addressed

to them on the subject of technical education, had agreed upon a further report (see page 155), which, with their report of November 4 last, they submitted for the consideration and approval of the Council.

#### Motion by Mr. Pell.

Mr. PELL, in moving "That the Council approve of a Normal School of Agriculture for Scientific Instruction," said he was afraid that the motion of which he had given notice must take the character of an amendment to the motion of Mr. Dent, because if the Council committed themselves to the acceptance and adoption of the report, he was at once barred from moving further. The feature of the Education Committee's report of November 5,<sup>1</sup> which immediately concerned the Council, was the disagreement with the first recommendation of the report on technical education in agriculture, prepared by the Joint Committee of the Central Chamber of Agriculture and the Farmers' Club. That recommendation was "That there should be established and maintained, at the cost of the State, a central normal school of agriculture." On the whole, the Education Committee, in considering that report, agreed to the recommendations with the very striking exception of the first one, and (one not so material) of the sixth and last recommendation of the Joint Committee. He entirely agreed in the feeling of their own Committee in not wishing to endorse the sixth recommendation; but he had a very strong opinion with regard to the first. There was no occasion to go over the ground again, because the proceedings of the Council of November 5 had been in print, and had been before the public for three months. He had first to ask the Council for one moment to consider the grounds which he had for taking up his present attitude; and secondly, the position in which they found the subject in the deliberations of that Council. Probably that position was the outcome of circumstances. Their motto was "Practice with Science," and he thought science must not be

forgotten. How was science dealt with in the Council? It was dealt with in two Committees—the Chemical Committee and the Committee on Education. The greater part of the time of the Chemical Committee was taken up in dealing with what he might call "commercial transactions." Their time was occupied in protecting members of the Society from the fraud of dishonest dealers in manure and feeding-stuffs. To this Committee there was a Subcommittee, called the Woburn Subcommittee. That was distinctly a scientific committee—a committee which concerned itself with research, in which, as they all knew, they had received the most direct and valuable assistance from the historic house of Russell. There remained, then, the Education Committee. The consideration of the report of that very important committee had somehow got to the bottom of the sack. It was, he believed, almost the last report which the Council dealt with in the arrangement of its proceedings. The report of November 5 had received the same sort of treatment that this report had met with. It was then decided that the subject should be postponed for further and more serious consideration.

It was in order to give some direct line to the way in which they should broach the question that he had ventured to make the motion which stood in his name. A great many members of Council had entirely misapprehended his motion. They had taken it to imply a central school established by the State, controlled by the State, and maintained by the State, and that what he had to say referred to State establishment and control. Some, again, had thought that in his motion was implied a farm—an experimental, or what was called a model farm—which was generally, as far as his experience went, a model of all that they ought not to do. Many members appeared to have left the Council under the impression that he was advocating State control and a model farm. He should be sorry for their having come to such a conclusion; he only asked them to endorse his motion in the precise terms which he had proposed: "That

<sup>1</sup> See Vol. i. Pt. iv. (1890), page 851.

the Council approve of a Normal School of Agriculture for Scientific Instruction." He did not pose as a scientist himself; he had no scientific knowledge; he did not know that at seventy-one years of age he should attempt to acquire it. He shared with others, and especially with the manufacturing side of their community, the firm conviction that their future prosperity in agriculture, as their prosperity in the great iron trade and coal business, and in the other great operations which England conducted, must depend primarily upon science.

With reference to technical instruction, he had very grave doubts about its being of service. The present efforts were the result of the grant of a good deal of Government money. The popular idea was that the Chancellor of the Exchequer would renew the grants; that might or might not be the case. Now the Royal Agricultural Society, in furtherance of science, had applied recently the same methods it had applied in the improvement of stock—the prize system. They allocated 500*l.* a year to agricultural education; it was given for the most part in prizes. Acknowledging, as they did, the advantage of scientific training, they had done but very little of a direct and legitimate character in the production of the pupil. He had a list of the names of each institution who furnished them with their so-called scientific offspring—but which he was rather inclined to term chance children. Let them look at the list: Maybole, Northampton, Portsmouth, Norfolk, Devon, Ashburton, and Surrey County Schools, &c. They were not concerned with the curriculum or syllabus of any one of these institutions. It was sufficient for them if they sent up candidates for their prizes. He had seen, not long ago, a return of what became of these young men. Had they become agriculturists? The greater part of them were nothing of the sort. They had applied their minds sufficiently to get their scholarships and prizes, and then they went about their business all over the world. He employed the phrase "normal school" in its technical sense—an establishment where teachers of agriculture should be trained and produced. It was not

sufficient to make a teacher a scientific man, unless they conferred upon him also the art of imparting his knowledge to others—and that was an art for which there was likely to be a demand. They saw already that a number of new institutions—and some older ones—were taking up the question. He went to Bangor the other day, and he was delighted with what they were doing there. He had also gone to Yorkshire, and was there impressed with the idea that they meant to take up the teaching of agriculture. He could not expect any support from the speech of the oldest friend of education in that room—Mr. Dent—but he was going to get a little support from what Mr. Dent had recently put into print. In that supplementary report before the Council there was this passage:—

There is now, however, a demand for something beyond this. We are asked to provide competent teachers who may instruct classes in colleges or schools, or who may take their teaching to the country villages and towns, and so bring it home to the people interested.

He thoroughly endorsed that, but to have competent teachers they must bring them up to be competent teachers. Therefore he said and believed that they ought to do all they possibly could for the production of scientific teachers. Now the demand for scientific teachers would be best provided for by a normal school. He did not propose the direct establishment by the Royal Agricultural Society of a normal school. He merely said it was desirable that there should be one. He would take, as an example, the Yorkshire College at Leeds, on the Council of which there were many able men, not the least able of whom was Mr. Dent. He found that college in the pangs of child-birth with a scheme for agricultural education. Now supposing the thing came to its birth—and he had no reason to doubt it—they had another bantling. It might be a very useful bantling for his purpose. He should be very pleased if the Royal Agricultural Society could identify itself with this new scheme in Yorkshire, which was in a very good cen-

tral position, and if it ever saw the light and was likely to go on well, be to it something of a foster-mother. There were other institutions, such as Bangor, and it was possible that they might ally themselves distinctly and strictly with one of them. If his motion were carried then they came to details, and those details could only be dealt with by a special committee; therefore he only asked the Council to go with him to that extent. He knew that the Society had not done all that they should have done in the past. Perhaps they had done, however, all that circumstances permitted, and all that popular feeling required. There was very much still to be done in the way of scientific teaching; they must endeavour to get the better of a most dreadful conflict with the elements of the soil and the air, and find out how to get the most they could out of them. For himself, he was content to copy the best practice of his neighbours; but an institution must take higher views. Oxford had done so, and Cambridge was about to do so. He left those great institutions to carry out their own work. Therefore, should the Council feel inclined to accept the views which he had ventured to put forth, he proposed next to move that a committee be appointed to consider upon what lines the scheme should be carried out.

Mr. DENT thought a word or two would be expected from him in justification of the two reports, with the preparation of which he had had a good deal to do. He felt, if they accepted this supplementary report now presented, that they in no way barred future action if necessary. If it should be found in the course of twelve months or so that the bodies taking up agricultural education were failing in what they were doing, and were not likely to afford the means for scientific agricultural teaching, then Mr. Pell or any one else might bring up, perfectly unfettered by anything which might take place that day, a motion in favour of a normal school. But though he would not go back into the history of the educational struggles of that Society, he could not but think the teaching of agriculture in the schools mentioned by Mr. Pell had been a distinct advan-

tage. What they wanted to do was to spread a general knowledge of agriculture throughout the country; they wanted to facilitate the education of labourers as well as of farmers. The great difficulty, he had no doubt, would be to get pupils to attend; there were two difficulties—the want of pupils and the want of teachers. That report sketched out how they thought the thing might work. Large sums of money had been placed in the hands of the County Councils; at present they might only assist institutions in their own counties, but if the Government carried the measure which they had promised to introduce, they would be able to use a portion of the funds at all events in contiguous counties, so that neighbouring institutions might derive advantage. His idea, as accepted yesterday by the Education Committee, was, instead of having a normal school to be established with new buildings and laboratories, that they should subsidise existing institutions. He could speak, and Mr. Rowlandson also, as to the very practical scheme which would enable them to receive the sons of farmers at the Yorkshire College, and to give assistance in the way of providing lecturers to bring home the matter to the small towns and villages of Yorkshire, if it should be accepted by the Technical Education Committees of the Ridings. His opinion was that, until it was known what were the actual resources of the County Councils in regard to technical education in agriculture, they had better advise that existing institutions should be utilised. He thought very much of the idea of grouping round certain quarters, which was really a decentralisation from headquarters. It would be very desirable, when such institutions were formed, that there should be a conference of teaching bodies, and that they should decide upon the syllabus of their education. The Society might then give up having special examinations, and accept the examinations of the teaching bodies; and might instead give premiums or prizes, in the way suggested by the North Wales College, to a higher class of boys and young men, in order to encourage them to continue their agricultural studies. He did not



think that Mr. Pell and himself differed very much in this matter. He hoped the Council would not consider that they were debarred hereafter from taking up the question of a central college; but, for the present, if they accepted Mr. Pell's resolution they would at once pledge themselves to it.

Sir NIGEL KINGSCOTE expressed his approval of the report of the Education Committee. It seemed to him that Mr. Pell had spoken very much in the lines of the report until he came to that one subject—the establishment of a normal school. He ventured to think that Mr. Pell was premature about that. He thought they should not pledge themselves to anything of the kind until they saw what would happen within the next few months. He hoped the Council would pause before they adopted Mr. Pell's motion, and that they would adopt the report of the Education Committee.

MR. MAINWARING said that, at the meeting of the Education Committee last November, he had voted with Mr. Pell; since that time he had been permitted to join the committee of the Bangor College. If they passed a resolution of the kind proposed by Mr. Pell, or if a central normal school were established, they would not only be taking the money of the State, but the Bangor authorities and the authorities of other institutions would be placed in a secondary position. Whereas, if they were allowed to start their present schemes, they would soon be able to prove whether they carried on their work satisfactorily. If it were proved that a normal school were desired, such an institution might be formed. At the present moment, he did not think that one was required.

The PRESIDENT wished to point out to Mr. Pell and to the Council what an important matter his motion really was as to the establishment of a normal school. There were already existing in the counties very considerable means of training young men to become teachers. He did not know whether the Council were aware that the Science and Art Department of South Kensington assisted agricultural science through the medium of training colleges for teachers—the

very point at present under discussion. One of the alternative subjects which teachers in training colleges might take up was the principles of agriculture, so that means for the training of teachers did exist already. He did not understand that anybody had seconded Mr. Pell's motion, but he should like to say this: local action was being taken all over the country, and almost every County Council was engaged in considering applications for assistance. Until they know how they would deal with all applications from the many institutions, particularly in the North of England, which had applied for assistance, and until they knew how much would be allocated to agriculture, they really did not know where they were. The principle upon which the County Councils were acting appeared to be to help those who helped themselves.

Mr. Pell's amendment, not being seconded, fell to the ground, and the report of the Education Committee, together with the Special Report of November 5, and the Supplementary Report submitted on the present occasion, was received and adopted.

#### Dairy.

MR. MAINWARING reported the election of the Hon. C. T. Parker as Chairman of the year. A letter had been received from Miss Maidment accepting the appointment of Dairy Demonstrator at Doncaster upon the terms proposed by the Council. The Committee recommended for acceptance an arrangement with the railway companies, for the payment by the Society of a fixed sum per package for the carriage of poultry to and from the Showyard at Doncaster.

#### Railway Rates.

MR. FRANKISH said that the proposals of the Board of Trade, with reference to railway rates, were very unsatisfactory to agriculturists. It was necessary that traders should be in a position to defend the agricultural interest as well as they could. He moved, therefore—

That an additional grant of 100% be made to the Mansion House United Association on Railway Rates, for the further defence of agricultural interests.

Mr. SUTTON seconded, and the motion was carried unanimously.

#### Suggestions made at General Meeting.

The Council then proceeded to consider the suggestions made by members at the General Meeting held on December 11, 1890, and agreed, on the recommendation of the several Committees concerned, to reply as follows:—

Mr. GEORGE BARHAM: *That a sum not exceeding 1,000l. should be expended by the Council, if necessary, for the purpose of protecting the interests of English Agriculturists in reference to the proposed revision of railway rates by the Board of Trade.*

This has been dealt with by Mr. Frankish's motion referred to above.

Mr. W. LIPSCOMB: *That greater publicity should be given to the Society's Junior Scholarships.*

As stated by Earl Cathcart at the General Meeting, the Society's examinations are regularly advertised in the agricultural and educational newspapers; and not long ago, when the syllabus was revised, it was posted to the head master of every grammar school in the kingdom.

Mr. CHARLES LAURIE: *That prizes should be given for agricultural stations and marcs, as well as for agricultural geldings.*

This matter has been considered by the Stock Prizes Committee, who do not recommend any present action in the matter, as the question has previously been under the considera-

tion of the Council on several occasions, and the prizes for agricultural horses are this year offered by the Doncaster Local Committee.

Mr. J. KERSLEY FOWLER: *That attention should be given to the instruction of agricultural children upon various branches of rural knowledge, e.g., plants or insects that are valuable or injurious to the agriculture of their districts.*

The whole question of diagrams of plants and insects, and of elementary text-books on agricultural subjects, is now engaging the attention of the Education Committee.

Surgeon-Major INCE, M.D.: (1) *That the Society should hold occasional meetings for the discussion of subjects of agricultural importance; and (2) that it should issue a weekly Journal.*

(1) Meetings of the kind referred to were formerly held, but had to be given up on account of the lack of interest shown in them by members. (2) The Council, having, after full consideration, decided last year to produce the Journal at quarterly intervals, are unable now to re-open the matter.

#### Dates of Forthcoming Meetings.

Various letters and other documents having been read, the Council adjourned until Wednesday, March 4, and it was at the same time arranged that the next following meeting should be held on Wednesday, April 8, as the first Wednesday of that month (April 1) will fall in Easter week.

WEDNESDAY, MARCH 4, 1891.

THE EARL OF RAVENSWORTH (PRESIDENT) IN THE CHAIR.

**Present:—**

*Trustees.*—Earl Cathcart, Mr. John Dent Dent, Lord Egerton of Tatton, Col. Sir Nigel Kingscote, K.C.B., Sir A. K. Macdonald, Bart., Duke of Richmond and Gordon, K.G.

*Vice-Presidents.*—Earl of Feversham, Lord Moreton, Sir John Thorold, Bart., Mr. C. Whitehead.

*Other Members of Council.*—Mr. G. M. Allender, Mr. Alfred Ashworth, Mr. Joseph Beach, Mr. J. Bowen-Jones, Mr. Chandos-Pole-Gell, Mr. Charles Clay, Earl of Coventry, Mr. Percy Crutchley, Mr. S. P. Foster, Mr. William Frankish, Mr. R. Neville Grenville, Mr. James Hornsby, Mr. Charles Howard, Mr. C. S. Mainwaring, Mr. Joseph Martin, Mr. T. H. Miller, Hon. Cecil T. Parker, Mr. Albert Pell, Mr. Daniel Pidgeon, Mr. J. E. Ransome, Mr. S. Rowlandson, Mr. G. H. Sanday, Mr. W. T. Scarth, Mr. A. J. Smith, Mr. Henry Smith, Marquis of Stafford, Mr. E. Wilfrid Stanyforth, Mr. Martin J. Sutton, Mr. J. P. Terry, Mr. R. A. Warren, Mr. E. V. V. Wheeler, Sir Jacob Wilson.

Professor Brown, C.B.

*Officers.*—Mr. Ernest Clarke, Secretary and Editor; Dr. J. Augustus Voelcker, Consulting Chemist; Mr. Wilson Bennison, Surveyor.

The following members of the Doncaster Local Committee were also present: The Mayor of Doncaster (Mr. Alderman Stockil), Mr. F. Bacon Frank, Mr. John White, Mr. G. T. Wood, Mr. G. B. C. Yarborough, and Mr. George Chafer (Secretary of the Local Committee).

Letters of apology for non-attendance were read from Viscount Emlyn and Mr. Darby.

**Introduction of New Member of Council.**

Mr. E. Wilfrid Stanyforth, of Kirk Hammerton Hall, York, elected at

the last meeting to fill the vacancy on the Council, caused by the acceptance of the office of Vice-President by H.R.H. Prince Christian, K.G., attended for the first time, and was formally introduced by Earl Cathcart, Chairman of the Committee of Selection, who said he was sure from his knowledge of Mr. Stanyforth that he would make a very useful Member of Council.

**Election of New Members.**

The minutes of the Council held on February 4 last having been read and confirmed, the election of the following Governor and 104 Members was proceeded with:—

*Governor.*

SOUBERBIELLE, Edouard. .78 Cromwell Rd., S.W.

*Members.*

AKERS, E. . . Pentrebane Farm, St. Fagan's, Cardiff.  
 ALSOPP, T. . . North Kilworth, Rugby.  
 ANDERTON, G. H. . . Kilpin Lodge, Howden.  
 BAKER, W. . . Lapal, Quinton, Birmingham.  
 BARTON, J. . . Hopwas House, Tanworth.  
 BEDDALL, J. F. . . The Park, Marston, Amptihill.  
 BENNETT, H. C. Leigh. . Thorpe Place, Chertsey.  
 BLAKEY, G. S. . . Vienna, Austria.  
 BOOTH, J. . . Northwick Hill Farm, Blockley, Worcester.  
 BOSVILLE, T. B. . . Ravenfield Park, Rotherham.  
 BREWIS, E. F. . . Bellasis Farm, Stannington, Cramlington.  
 BROOKE, John Walter. . Lowestoft.  
 BROOKS, W. J. . . Boughton Grange, Northmpton.  
 BROOKSBANK, B. H. . . Sandrock, Tickhill, Yrks.  
 BRYMER, W. E. . . Ilington House, Dorchester.  
 CABTWRIGHT, R. W. . . Cholmondeley, Whitchurch, Salop.  
 CLAYTON, T. . . Park Hall Fm., Castle Bromwich.  
 CORNEY, D. . . Wellington House, St. Mary's, Ramsey, Hunts.  
 COULMAN, J. C. . . Bradholme, Thorne, Yrks.  
 CREWS, C. T. D. . . Billingbear, Wokingham.  
 CROMPTON, J. R. . . Bury, Lancashire.  
 CROMPTON, Ralph. . . Bury, Lancashire.  
 CROOK, A. W. . . Chapel Walks, Preston.  
 CROUCH, J. H. . . 6 Hall Gate, Doncaster.  
 CURREY, E. S. . . Erlwood, Bagshot.  
 DARGUE, T. . . Burneside Hall, Kendal.  
 DEAKIN, Edward. . Belmont, near Bolton.  
 DONKIN, F. W. . . The Warren, Hershams.  
 DRAKE, Richard. . Sutton, Ely.  
 DRINKWATER, G. E. . . Handley Park Farm, Norbury, Whitechurch, Salop.  
 DUNSTON, G. . . Hatfield, near Doncaster.  
 EDWARDS, A. R. . . Cambridge.  
 FORREST, H. P. . . Worksop, Notts.

FOSTER, H. . . Newbegin, Filey, Yorks.  
 GIBSON, S. W. . . Fynsford, Kent.  
 GOUGH, W. . . Hengrave, Bury St. Edmunds.  
 GRANT, W. Maling. . . Bhalgalpur, Bengal.  
 GREENSLADE, S. P. . . The Elms, Utting, Maldon.  
 HAMILTON, J. C. . . Sutton, Ferrybridge, Yorks.  
 HARGREAVES, F. . . Green Bank, Pendleton.  
 HARGREAVES, P. . . Newbrook, Atherton.  
 HARTLEY, C. M. . . Hexthorpe, Doncaster.  
 HAYNES, H. S. . . Upminster, Romford.  
 HODGSKIN, J. T. . . Marbury Hayes Farm, Marbury, Whitechurch, Salop.  
 HOWARD, J. . . Paget Hall, Gargrave, Yorks.  
 HUNTER, Cavill. . . The Lodge Farm, Worksop.  
 ISHERWOOD, S. jun. . . Shorefield, Dunscar, Bolton-le-Moors.  
 JOLLET, Pierre. . . Neuville's Farm, par Chaumont-en-Vexin, Oise, France.  
 JONES, W. . . Pen Porchell, Llanefydd, Trefnant, Rhyl.  
 LAKEMAN, J. . . Imperial Buildings, Leeds.  
 LANGDON, J. C., J.P. . . Parrock's Lodge, Chard.  
 LEES, G. J. D. . . Woodhill, Oswestry.  
 LUKER, H. . . Farringdon House, Southend.  
 MACHIN, A. V. . . Gateford, Worksop.  
 MACHIN, G. V. . . Gateford, Worksop.  
 MACINNES, Neil, J.P. . . Rickerby, Carlisle.  
 MACKINTOSH, Alexander. . . Cambridge.  
 MALDEN, Walter J. . . Cardington, Bedford.  
 MARSDEN, Thomas. . . Barnsley, Yorks.  
 MAUGHAN, J. . . Ingleby, Barwick, Yorks.  
 MOLYNEUX, Colonel Edmund. . . Warren Lodge, Finchampstead, Wokingham, Berks.  
 MORSHEAD, Sir Warwick, Bart. . . Forest Lodge, Binfield, Bracknell, Berks.  
 MOSS, F. J. . . Stainfield Hall, Wragby.  
 MOSS, J. . . Checker House Farm, Retford.  
 MULLOCK, W. B. H. . . Bellair, Ballycumber, Ireland.  
 NELSON, T. . . Cockermouth Castle, Cumberland.  
 ORANGE, J. . . Beddington, Northumberland.  
 OTRANTE, Duke d'. . . Elghammar, Björnunda, Sweden.  
 ORENDEEN, P. D. N. Dixwell. . . Broome Pk., Kent.  
 PEACE, A. L., C.E. . . Thorne, Doncaster.  
 PEDDAR, W. S. . . Higham Hall, Bury St. Edmunds.  
 POPE, E. P. . . Loversall Hall, Doncaster.  
 PROCTER, W. A. . . Rylstone, Skipton-in-Craven.  
 RADCLIFFE, David Clarke. . . Mold, Flintshire.  
 RAYNES, Francis. . . Bawtry, Yorks.  
 RHODES, W. . . Lundholme, Westhouse, Yorks.  
 RIGHTON, E. G. . . Evesham.  
 ROBINSON, J. . . King Charles Croft, Leeds.  
 ROEBUCK, W. . . Greylands, Horsell, Surrey.  
 ROSS, Rev. J. C. . . Wadworth Hall, Doncaster.  
 SHILTON, A. J. . . Science Institute, Reading.  
 SKENE, W. B. . . Christ Church, Oxford.  
 SMITH, H. J. . . Coldham Hall, Wisbech.  
 SMITH, J. . . Sudlow Farm, Knutsford.  
 STANSFIELD, W. . . Marston Lodge, Leeds.  
 STOCKIL, Charles. . . Mayor of Doncaster.  
 STONE, A. E. . . The Stalls, Worcester.  
 STUBBS, W. . . Weeping Cross, Stafford.  
 TETT, H. S. . . Faversham.  
 THORNLEY, W. . . Hurdle Hall, Bickenhill.  
 TOUGH, A. . . Upper Mitton, Stourport.  
 TRAVIS, E. . . 113 Queen's Road, Dalston, E.  
 WALKER, H. S. . . Netherthorpe, Worksop.  
 WARNER, A. E. . . Manor Lodge, Botley, Hants.  
 WEDDALL, G. E. . . Thornton House, Brough.  
 WHITE, John. . . Clansfield, Faringdon.  
 WHITEHEAD, Rowland. . . 14 Old Square, W.C.  
 WILLIAMS, J. . . Merthermawr, Bideford.  
 WILSON, C. M. . . Waldershaigh, Bolsterstone.  
 WILSON, John. . . Bickenhill, Birmingham.  
 WRIGHT, W. C. . . Catherine Street, Doncaster.  
 WYNN, Hon. P. G. . . Glynulifon Park, Carnarvon.

YATES, Ralph. . . Malton, Yorks.  
 YEARDLEY, John. . . Model Mill, Sheffield.

The reports of the various Standing Committees were then presented and adopted as below:—

### Finance.

Sir NIGEL KINGSCOTE (Chairman) reported that the accounts for the month of February, as certified by the Society's accountants, showed total receipts amounting to 1,003*l.* 2*s.* 4*d.*, and expenditure amounting to 1,056*l.* 9*s.* 3*d.* The balance at the bankers on the 28th February, allowing for cheques outstanding, was 5,616*l.* 6*s.* 11*d.* Accounts amounting in all to 2,075*l.* 1*s.* 10*d.* had been passed, and were recommended for payment. The Committee recommended that the names of one governor, three life members, and two annual members, deceased, eighteen members who had resigned, and nine in arrears with their subscriptions, be struck off the register.

Sir NIGEL KINGSCOTE also announced that the Auditors had completed on Monday their audit of the Society's accounts for the year 1890. The final result was that, after writing off the customary percentages for depreciation, the Society's assets amounted at the 31st December, 1890, to 35,176*l.* 13*s.* 2*d.*, as against 38,056*l.* 7*s.* 10*d.* at the end of 1889. The Auditors had also presented a valuable report on the relations of life compositions to revenue, in which they recommended that all life compositions received in future should be placed to the reserve fund, and that out of this fund should be paid each year the cost of providing with their privileges the life members then on the books. He laid this report, upon the table, and suggested that it might usefully be printed in the next number of the Journal, with the balance-sheet and other statements of account (see pages xii to xxi).

### Journal.

Earl CATHCART (Chairman) reported the receipt of applications from various institutions for free copies of the Journal, as to which directions had been given to the Secretary. The Committee recommended that breeders' cards be ad-

mitted to the advertisement pages of the Journal at the same charge as other advertisements. The Secretary had submitted his proposals for the articles in the forthcoming number of the Journal, which were approved.

#### Chemical.

Mr. WARREN (in the absence of Viscount Emlyn, Chairman) reported that various details connected with the Society's laboratory had been discussed and settled. The report of the Woburn Sub-Committee had been received and adopted. The Committee presented their Quarterly Report, which, on the motion of Mr. WARREN, was adopted and ordered to be published (see page 157).

#### Seeds and Plant Diseases.

Mr. WHITEHEAD (Chairman) reported that Miss Ormerod had presented a report which the Committee recommended for publication (see page 168). The Committee had received samples of two new grasses called respectively "new late-flowering cocksfoot" and *Anthoxanthum amarum* or "mammoth sweet vernal," and they recommended that these should be tried at Woburn under the supervision of the Consulting Botanist. A request had been received from the Irish Land Commission asking the Council to suggest the names of persons in a position to give information on the subject of Forestry, and the Committee had given directions to the Secretary as to the suggestion of certain names of gentlemen in Scotland. They would be glad if Members of Council would send to the Secretary the names of any gentlemen in England qualified to give assistance in this matter.

Mr. WHITEHEAD pointed out that Miss Ormerod in her report drew special attention to the fact that the hard frost and the severe weather during the recent winter had not had the slightest effect upon insect life. It was commonly supposed that frost had the power of killing insects, and that, therefore, they would be free from insect plagues during the next season. He was afraid that their hopes would be disappointed, and he would advise all those who were troubled with insect pests during the

past year to take precautions for the coming season.

#### Veterinary.

Sir JOHN THOROLD (Chairman) reported that a letter had been read from Mr. Lewis P. Rees, of Carmarthen, accepting the post of Provincial Veterinary Surgeon for Carmarthenshire. A form of petition to the President of the Board of Agriculture on the subject of the sale as British meat of imported American cattle, and of the present restrictions on home cattle, which had been received from the North-West Cattle Trade and Farmers' Defence Association, had been ordered to lie upon the table. The Farriers' Company had reported that nearly 200 applications for registration had already been received under the scheme for the National Registration of Farriers or Shoeing-smiths.

Professor Brown had presented the following report:—

*Pleuro-pneumonia*.—During the four weeks ended February 21st there were seventy-five cattle affected with this disease slaughtered in Great Britain in the counties of Hants, Kent, Lancaster, London, Surrey, Warwick, York (W.R.), Forfar, Lanark, Midlothian, Perth, and Renfrew. In the same period 930 healthy cattle which had been exposed to the risk of infection were slaughtered in the counties of Durham, Hants, Kent, Lancaster, London, Surrey, Warwick, Wilts, York (W.R.), Aberdeen, Forfar, Lanark, Midlothian, Perth, Renfrew, and Sterling.

*Anthrax*.—There were eleven fresh outbreaks of this disease reported in Great Britain in the counties of Dorset, Northampton, Notts, Warwick, York (E.R.), and York (W.R.). In these outbreaks twenty-two animals were attacked, two were killed, nineteen died, and two recovered.

*Swine Fever*.—During the four weeks 212 fresh outbreaks of this disease were reported in Great Britain; 1,391 swine were attacked, 745 diseased pigs were killed, 601 died, 232 recovered, and 201 remained alive when the return was made up.

*Rabies.*—In England nine cases of this disease were reported in the four weeks in the counties of Essex, Hants, Kent, London, Middlesex, and York (W.R.).

#### Stock Prizes.

Mr. SANDAY (Chairman) reported that a letter had been received from the British Berkshire Society agreeing to the conditions under which their proposed champion prize of 10*l.* would be accepted by the Royal Agricultural Society.

#### Judges' Selection.

Mr. SANDAY (Chairman) reported that the Committee had examined the list of gentlemen nominated as Judges, and that with very few exceptions the invitations had been accepted. They had given instructions for the completion of the list.

#### Implement.

Mr. FRANKISH (Chairman) reported the Committee's recommendation that the trials of Threshing Machines commence on Monday, June 15th, at 3 p.m. The Committee had considered and revised a proposed schedule of prizes and regulations for Ploughs and Horse-diggers in 1892, and they recommended that a copy as amended be forwarded to each member of the Council before the next meeting.

Mr. HORNSBY said he desired to make a statement to the Council, as he had already done to the Implement Committee, relative to the proposed prizes for Ploughs. Last year, as they would remember, he was placed in a very disagreeable position with reference to the prizes for Threshing Machines. He wished, therefore, to say that as regarded the proposed trials of Ploughs next year, his firm must be held as being at liberty to decide whether they would compete or not, though he himself would be ready, as a personal matter, to give every assistance to the Council in the settlement of the system under which the Plough Trials should take place, if it should be the decision of the Council to have these trials.

Mr. RANSOME thought it would be generally agreed that every Member of the Council ought to speak out

about a matter on which he felt strongly. It was somewhat disagreeable to him, but he felt that he would not be doing his duty unless he did speak out upon this question of the Plough Trials. The Council decided at the last meeting that there should be trials for ploughs in connection with the Warwick Meeting, and he supposed they could not rescind their resolution. He was very strongly of opinion that they were offering money for that which would result in very little benefit. Ordinary Horse Ploughs had been thoroughly tried at past Meetings of the Society, at Warwick, Newcastle, Leicester, and Hull. Any prizes they might like to offer would be of very little utility in bringing out practical improvements; it would, therefore, be a very considerable waste of money. If they wished to offer prizes for ploughs, he would like to move:—

That it be an instruction to the Committee in preparing the schedule for the Plough prizes that ordinary single and double-furrow ploughs should not be included.

He believed the Society could offer prizes which would be much more valuable and of much more benefit to agriculture than these.

Mr. Ransome's motion, not being seconded, fell to the ground, and the report of the Committee was then adopted.

#### General Doncaster.

Mr. DENT reported that the Local Committee had appointed Mr. J. H. Crouch, of 6 Hall Gate, Doncaster, as Official Agent for the letting of houses and lodgings. The Committee recommended that the Band of the Yorkshire Dragoons be engaged to play selections of music three times a day on the Tuesday, Wednesday, Thursday and Friday of the Doncaster Meeting. Arrangements had been made with the Vicar of Doncaster as to the holding of the usual Sunday Service previous to the opening of the Show, and the Archbishop of York had kindly consented to preach the sermon on that occasion.

#### Showyard Works.

Mr. CLAY reported that the Showyard Works at Doncaster had been

commenced, and that timber and other materials for the works were being received. The Local Committee were laying down the sleeper roads and water mains. The Surveyor's accounts had been passed, and various recommendations as to payments were presented. An offer from the Shap Granite and Patent Concrete Company, Limited, to lay the flooring of the dairy with their patent granite concrete, free of charge, had been accepted.

### Education.

Lord MORETON (Chairman) announced that the Committee had carefully considered a report presented by the Sub-Committee, to whom had been remitted the subject of text-books in agriculture for use in elementary and continuation schools; and they agreed with the Sub-Committee in thinking that the preparation of a text-book ought to be undertaken by the Royal Agricultural Society. They recommended, therefore, that such a text-book should be prepared under the auspices of the Society, and should be published with its authority.

Various letters and documents relating to technical education in agriculture had been laid upon the table. The following time-table for the Senior Examination to be held next May had been considered and approved:—

Tuesday, May 12.	
Land Surveying . . . . .	10 a.m. to 1 p.m.
Agriculture (written paper) . . . . .	2 p.m. „ 5 p.m.
Wednesday, May 13.	
Agricultural Engineering . . . . .	10 a.m. „ 1 p.m.
Agricultural ( <i>à la voce</i> ) . . . . .	2 p.m. „ 5 p.m.
Thursday, May 14.	
Chemistry (General) . . . . .	10 a.m. „ 1 p.m.
Chemistry (Agricultural) . . . . .	2 p.m. „ 5 p.m.
Friday, May 15.	
Book-keeping . . . . .	10 a.m. „ 1 p.m.
Botany . . . . .	2 p.m. „ 4 p.m.
Agricultural Entomology . . . . .	4 p.m. „ 5 p.m.
Saturday, May 16.	
Geology . . . . .	10 a.m. „ 1 p.m.
Anatomy . . . . .	2 p.m. „ 4 p.m.

In the course of the discussion on this report, Lord MORETON said that the Committee quite felt that the price of the proposed text-book must be kept as low as possible.

Mr. DENT said he would like to suggest that after they had issued

this text-book the Society should endeavour, if it could, to get out some good reading-books. The text-book would be a thoroughly scientific handbook to agriculture; but really the reading-books which children had in the elementary schools for the poorer classes were most unsuitable. Books that would give an interest to the children in country life would be far more useful. He remembered an old book called "Eyes and no Eyes," which described what one could see and learn in the country if one used one's eyes, and how much one might lose by not using one's eyes. If such reading-books were obtainable, they would be a great deal more useful than those now in existence; but, for the present, the Society had enough to do.

### Country Meeting of 1892.

On the motion of the Hon. CECIL T. PARKER, seconded by Sir JACOB WILSON, the Society's seal was authorised to be affixed to the agreement with the Corporation of Warwick as to the Country Meeting of 1892.

### International Agricultural Congress at the Hague.

The SECRETARY reported that he had received a communication from the Executive Committee of the International Agricultural Congress which would be held at the Hague from September 7th to 12th next, asking him to undertake for England the issue of programmes and the giving of information relative to the Congress to those interested in the subject. Permission to do this was granted by the Council.

### Dates of forthcoming Meetings.

Various letters and other documents having been laid upon the table, the Council adjourned until Wednesday, April 8th, 1891 (instead of April 1st, Easter Wednesday); and it was at the same time arranged that the remaining meetings of the session should be held on the following dates:—Wednesdays, May 6th, June 3rd, June 24th (in the Doncaster Showyard), and July 29th.

## PRINCIPAL ADDITIONS TO THE LIBRARY DURING THE YEAR 1890.

*[The name of the Donor, or the mode of acquisition, appears in italics  
after the title of each work.]*

- AGRICULTURA, Ministero di, Industria e Commercio, Coltivazioni Sperimentali.  
Vol. I. 8vo. Rome, 1889.....*Govt. of Italy*
- Annales Agronomiques. Vol. XVI. 8vo. Paris, 1890. ....*Govt. of France*  
— de la Science Agronomique Française et Etrangère. Par L. Grandeau.  
Année VII. Fasc. 1. 8vo. Paris, 1890 .....*Author*
- Annali di Agricoltura, 1890. 8vo. Rome, 1890 .....*Govt. of Italy*
- Atlas der Urproduction Oesterreichs. Fol. Vienna .....*Govt. of Austria*
- Atlas of the World. Library Reference. 4to. London, 1890.....*Purchased*
- BARRAL, J. A., Dictionnaire d'Agriculture. Fasc. 21-23. 8vo. Paris, 1890.  
*Purchased*
- Bericht über die Thätigkeit des K. K. Ackerbau-Ministeriums, 1868; 1869 to  
June 30, 1874; July 1, 1874, to June 30, 1875; July 1, 1875, to Dec.  
31, 1876; 1877 to 1880; 1881 to 1886. Seven volumes. 4to. Vienna,  
various dates .....*H.E. Count von Falkenhayn*
- Bericht über die Verhandlungen und Beschlüsse des internationalen land- und  
forstwirthschaftlichen Congresses in Wien, 1890 ...*Congress Committee*
- Board of Trade Journal. Vols. VIII., IX. 8vo. Lond., 1890. *Board of Trade*
- Bunyard, G., Fruit Farming for Profit (up to date). 3rd Edit. 8vo.  
Maidstone, 1890.....*Author*
- CENSO Agricolo-Pecuario de la Provincia de Buenos Aires, 1888. 8vo. Buenos  
Ayres, 1889.....*Argentine Republic*
- Coghlan, T. A., The Wealth and Progress of New South Wales, 1888-9.  
3rd Ed. 8vo. Sydney, 1889.....*Author*
- Comptes Rendus des Travaux de la Société des Agriculteurs de France.  
Tome XXI. 8vo. Paris, 1890.....*Society*
- Congrès International d'Agriculture à Paris, 1889 .....*Purchased*
- Cotes, E. C., Notes on Economic Entomology. Vol. I Nos. 3, 4. 8vo.  
Calcutta, 1890.....*Trustees Ind. Mus.*
- DAY, William. The Horse, How to Breed and Rear him. 2nd Ed. 8vo.  
Lond., 1890.....*Author*
- Dehérain, P. P., Travaux de la Station Agronomique de l'École d'Agriculture  
de Grignon. 8vo. Paris, 1889.....*Author*
- ENCYKLOPAEDIE der gesammten Thierheilkund und Thierzucht. Herausge-  
geben von Alois Koch. Vols. I.-VIII. 8vo. Vienna and Leipzig,  
1885-91 .....*Purchased*
- FLEMING, Dr. George. Horse-shoes and Horse-shoeing: Their Origin, History,  
Uses, and Abuses. 8vo. Lond., 1869.....*Purchased*
- Flock Books :—*
- Oxford Down Flock-Book. Vol. II. 8vo. London, 1890 .....*Society*
- Flock-Book of Suffolk Sheep Vol. IV. 8vo. 1890 .....*Society*
- Flock-Book of Wensleydale Long Wool Sheep. Vol. I. 8vo. ....*Society*
- GAUWAIN, Législation Rurale. 8vo. Paris, 1890.....*Purchased*



- Giglioli Prof. E. H., Primo Resoconto dei Risultati della Inchiesta Ornitologica in Italia. Parte Seconda. Avifauna Locale. Risultati della Inchiesta Ornitologica nelle Singole Provincie. 8vo. Florence, 1890.....*Author*
- Goltz, Dr. Theod. Freiherr von der, Handbuch der gesammten Landwirthschaft. Lief. 12-15. 8vo. Tübingen, 1890.....*Purchased*
- Grandeau, L., Etudes Agronomiques. Séries I.-IV. (1885-89). 8vo. Paris, 1888-89.....*Publishers (Hachette et Cie.)*
- Greenwich, Royal Observatory, Results of the Magnetical and Meteorological Observations, for 1887. 4to. Lond., 1889.....*Roy. Observatory*
- Gresswell, J. B., and A. Gresswell. A Manual of the Theory and Practice of Equine Medicine. 2nd Edit. Revised by G. Gresswell. 8vo. Lond., 1890.....*Publishers (Baillière, Tindall, and Cox)*
- The Equine Hospital Prescriber. 2nd Edit. Revised by G. Gresswell. 8vo. London, 1890.....*Publishers (Baillière, Tindall, and Cox)*
- HANDLINGAR och Tidskrift, Kongl. Landtbruks-Akademiens. År 1890. 8vo. Stockholm, 1890.....*Akad.*
- Hartig, Dr. R., Timbers and how to Know them. Translated by W. Somerville, D.Sc. 12mo. Edinburgh, 1890 .....*W. Somerville*

*Herd-Books :—*

- Herd-Book Argentino para la Raza Vacuna Shorthorn Perfeccionada. (Durham.) Vol. I. 8vo. Buenos Ayres, 1889.....*Society*
- Coates's Herd-Book. Vol. XXXVI. 8vo. London., 1890...*Shorthorn Soc.*
- Davy's Devon Herd-Book. Vol. XIII. 8vo. Exeter, 1890.....*Society*
- Frisian Herd-Book. Vol. XVI. 8vo. Leeuwarden, 1890....*Consul Nethlds.*
- Galloway Herd-Book. Vol. X. 8vo. Dumfries, 1890.....*Society*
- Guernsey Herd-Book. Vol. V. 8vo. Guernsey, 1890.....*Society*
- Herd-Book of Hereford Castle. Vol. XXI. 8vo. Hereford, 1890...*Society*
- North Wales Black Cattle Herd-Book. Vol. III. 8vo. Bangor.....*Society*
- National Pig Breeders' Association Herd-Book. Vol. VI. 8vo. London, 1890.....*Association*
- Polled Herd-Book. Vol. XIV. 8vo. Banff, N.B., 1890.....*Society*
- Red Polled Herd-Book. Vol. IV. 8vo. Norwich.....*Society*
- Jersey Herd-Book. Vol. X. 4to. Jersey, 1890.....*Society*
- Register of Births of pure-bred Jersey Cattle. No. 7. 8vo. London, 1890.  
*Eng. Jers. Cattle Society*
- South Wales Black Cattle Herd-Book. Vol. V. 8vo. Carmarthen...*Society*
- Sussex Herd-Book. Vols. I.—V. 8vo. Lewes and London, 1879-90...*Society*

INSECT Life. Vols. II., III., Nos. 1-4. 8vo. Washington, 1889-90.  
*U. S. Depart. of Agric.*

- JAHRBUCH der Deutschen Landwirthschafts-Gesellschaft. Band 1-5. 8to. Berlin, 1887-91.....*Gesellschaft*
- der K. K. Landwirthschafts-Gesellschaft in Wien, 1889. 8vo. Vienna, 1890 .....*Gesellschaft*
- Jahresbericht der Agrikultur-Chemie. Neue Folge, XII. 8vo. Berlin, 1890.....*Purchased*
- der Königlichen Landwirthschafts-Gesellschaft zu Celle, for 1889. 8vo. Hanover, 1890 .....*Verein*
- der ausführenden Direktion des Schleswig-Holsteinischen Landwirthschaftlichen Generalvereins, for 1889. 8vo. Kiel, 1890 .....*Verein*
- Johnston, R. M. Tasmanian Official Record, 1890. 8vo. Tasmania, 1890  
*Author*

KORRESPONDENZ des Milchwirthschaftlichen Vereins. No. 34. 4to. Kiel, 1890 .....*Verein*

Kramer, Dr. Ernst, Die Bakteriologie in ihren Beziehungen zur Landwirthschaft und den Landw-Technischen Gewerben. 8vo. Vienna, 1890...*Purchased*

xlvi *Principal Additions to the Library during the Year 1890.*

LANDWIRTHSCHAFTLICHE Jahrbücher. Band XIX. 8vo. Berlin, 1890.  
*Dept. of Agric.*  
 — Bd. XIX. Ergänzungsbd. I. and II. 8vo. Berlin, 1890... *Dept. of Agric.*  
 Larbalétrier, Prof. A., Manuel Pratique du Drainage des Terres Arables. 8vo.  
 Paris, 1890 ..... *Purchased*  
 Lawes, Sir John B., Memoranda of Origin, Plan, and Results of Field and  
 other Experiments at Rothamsted, Herts. 4to. Lond., 1890 ... *Author*  
 Lippiza, Das K. K. Hofgestüt zu Lippiza, 1580–1880. 4to. Vienna, 1880.  
*Austrian Master of the Horse*

MACKAY, T., The English Poor. 8vo. Lond., 1889..... *John Murray*  
 Mémoires publiés par la Société Nationale d'Agriculture de France. Tome  
 CXXXIII. 8vo. Paris, 1890 ..... *Society*  
 Mittheilungen des Vereines zur Förderung des Landwirthschaftlichen  
 Versuchswesens in Oesterreich. Heft V. 4to. Vienna, 1890.  
*Dr. Max Ritter von Proskowitz*  
 Morton, J. C., Labour of the Farm. 8vo. Lond., 1887 ..... *Purchased*  
 Mummery, A. F., and J. A. Hobson., The Physiology of Industry. 8vo.  
 Lond., 1889 ..... *John Murray*

NOTES on Indian Economic Entomology. Vol. I., Nos. 3, 4. 8vo. Calcutta,  
 1890 ..... *Trustees Ind. Mus.*

ORMEROD, Miss Eleanor A., A Manual of Injurious Insects, and Methods of  
 Prevention. 2nd Edit. 8vo. Lond., 1890 ..... *Author*  
 — Report of Observations of Injurious Insects and Common Farm Pests  
 during the year 1889, with Methods of Prevention and Remedy. 13th  
 Report. 8vo. Lond., 1890 ..... *Author*

*Parliamentary Papers :—*

Agricultural Produce Statistics of Great Britain,\* for 1889. 8vo. London,  
 1890 ..... *Board of Agriculture*  
 Agricultural Returns of Great Britain, &c., for 1890. 8vo. London, 1890.  
*Board of Agriculture*  
 Agricultural Statistics of Ireland, for 1889. Fol. Dublin, 1890..... *Govt.*  
 Army Veterinary Department, Annual Statistical and General Report, for  
 1889. Fol. London, 1890..... *Govt.*  
 Board of Agriculture. 3rd Annual Report on Insects and Fungi injurious to  
 the Crops of the Farm, the Orchard, and the Garden. By Chas.  
 Whitehead. 8vo. Lond., 1890..... *Board of Agric.*  
 Commercial Further Reports on the Agricultural Departments of Foreign  
 Countries. 8vo. Lond., 1890 ..... *Purchased*  
 Hop Industry, Report on the. Fol. Lond., 1890..... *Purchased*  
 Horse-Breeding, Royal Commission on. Reports 1–3. With Minutes of  
 Evidence and Digest. Fol. London, 1888–90..... *Royal Commission*  
 Pleuro-Pneumonia, Return relating to, of the last 3 years. Fol. Lond.,  
 1890 ..... *Board of Agriculture*  
 Potato Crop, Extracts from Reports upon the, made for the Irish Land  
 Commission, for 1890. Fol. Dublin, 1890 ..... *Govt.*  
 Reports on Broad Wheels, &c., Roads and Harbours, &c. 31 Reports. Fol.  
 Lond., 1806–32..... *Royal Society*  
 Reports on Land Tenure in Foreign Countries. Fol. Lond., 1870–72  
*Purchased*  
 Special Report on Insects, Fungi, and Weeds injurious to Farm Crops. 8vo.  
 Dublin, 1890 ..... *Irish Registrar-General*  
 Statistical Abstract for the several Colonial and other Possessions of the  
 United Kingdom in each year from 1874–88. No. 26. 8vo.  
 Lond., 1889..... *Board of Trade*

- Trade of the United Kingdom with Foreign Countries and British Possessions, Annual Statement for 1889. Fol. Lond., 1890...*Board of Trade*  
 Trade and Navigation Accounts for 1890. 8vo. Lond., 1890. *Board of Trade*  
 Veterinary Department, Annual Report for 1889. 8vo. Lond., 1890.  
*Board of Agriculture*  
 Woods and Forests and Land Revenues of the Crown. Report for 1889-90.  
 Fol. Lond., 1889-90.....*Purchased*
- PORTICI, R., Scuola Superiore d'Agricoltura. Annuario. Vols. I.-V. 8vo. Naples, 1878-85. Resoconto, for 1889-90. 8vo. Portici, 1890.  
*Roy. Agric. School*
- Powell, J. W., 5th and 6th Annual Reports of the Bureau of Ethnology. Roy. 8vo. Washington, 1887-8.....*Smithsonian Inst.*
- Protokolle der Sitzungen des Zentral-Ausschusses der Königlichen Landwirthschafts-Gesellschaft, Zentral-Verein für die Provinz Hannover, zu Celle. Heft 62. 8vo. Hanover, 1890.....*Verein*
- RELATORIO Annual da Estação Agronomica de Campinas em 1889. São Paulo, 1890.....*Govt. of Brazil*
- Rinder Racen, Die Oesterreichischen, Herausgegeben vom K. K. Ackerbau Ministerium:  
 Band I. Rinder der Oesterreichischen Alpenländer, Von Ferd. Kaltenegger. Heft I. Oberinntaler und Lechthaler Typus. 8vo. Vienna, 1879.  
 „ II. Montavoner Typus und Landvieh im Vorarlberg. 8vo. Vienna, 1880.  
 „ III. Etschthal und Wipphthal. 8vo. Vienna, 1884.  
 „ IV. Grau und Braunvieh in Italienisch-Südtirol. 8vo. Vienna, 1889.  
 Band II. Rinder des Donauthales in Ober- und Nieder-Oesterreich. Von Franz Zoepf.  
 Heft I. Ober-Oesterreich. 8vo. Vienna, 1881.  
 „ II. Nieder-Oesterreich. 8vo. Vienna, 1884.  
*Baron Arthur von Hohenbruck*
- Rodiczkv, Eugen, v., Studien über das Schwein. 8vo. Vienna, 1873 ...*Author*  
 — A. Kassai M. Kir. Gazdasagi Tanintézet Evkönyve az 1889, ik Evre. 8vo. Kassa, 1889 .....*Author*
- Ronna, A., Les Irrigations. Tome III. 8vo. Paris, 1890 .....*Purchased*
- SAUNDERS, Prof. W., Agricultural Colleges and Experimental Farm Stations. 8vo. Ottawa, 1886 .....*Author*
- Smith, F. A., Manual of Veterinary Hygiene. 8vo. London, 1887.  
*Publishers (Baillière, Tindall, and Cox)*
- Smith, Dr. R. M., The Physiology of the Domestic Animals. 8vo. Philadelphia and London, 1889.....*Publisher*
- Smithsonian Contributions to Knowledge. Vol. XXVI. Fol. Washington, 1890 .....*Institution*
- Statistical Year-Book of Canada, for 1889. 8vo. Ottawa, 1890. *Dominion Govt.*
- Statistics of the Colony of Tasmania, for 1889. Fol. Tasmania, 1890.  
*Govt. of Tasmania*
- Statistique Agricole, for 1888. 8vo. Paris, 1889 .....*French Min. Agric.*
- Statistische Ausweise über die Approvisionnement der Stadt Wien im Jahre 1889. 4to. Vienna, 1889 .....*Herr Joseph Zecha*
- Statistisches Jahrbuch des K. K. Ackerbau-Ministerium, for 1885-89. 8vo. Vienna, 1886-90 .....*H.E. Count von Falkenhayn*
- Steel, J. H., Diseases of the Sheep. 8vo. London, 1890...*Publishers (Longmans)*
- Stephens, Henry, The Book of the Farm. 4th Ed. Revised and in great part rewritten by James Macdonald. Divs. IV., V. 8vo. Edin. and Lond., 1890 .....*James Macdonald*

xlviiii *Principal Additions to the Library during the Year 1890.*

*Stud-Books:—*

- Cleveland Bay Stud-Book. Vol. VI. 8vo. Saltburn, 1889 .....*Society*  
 Clydesdale Stud-Book. Vol. XII. 8vo. Glasgow, 1890 .....*Society*  
 General Stud-Book. Vol. XVI. 8vo. London, 1889 .....*Purchased*  
 Hackney Stud-Book. Stallions and Mares. Vol. VII. 8vo. Norwich, 1890.  
*Society*  
 Shire Horse Stud-Book. Vols. XI. and XII. 8vo. London, 1890-91....*Society*  
 Suffolk Stud-Book. Vol. V. 8vo. Diss, 1890 .....*Assoc.*  
 Yorkshire Coach Horse Stud-Book of Great Britain and Ireland. Vol. III.  
 8vo. York, 1890 .....*Society*  
 Surveyors' Institution. Transactions and Professional Notes. London, 1890.  
*Inst.*  
 Sutton, Martin J., Permanent and Temporary Pastures. 4th Edition. 8vo.  
 London, 1891 .....*Author*  
 TALPA, or the Chronicles of a Clay Farm. By Chandos Wren Hoskyns.  
 Sixth Edition. 8vo. London, 1889.....*Purchased*  
 Thornton's Circular. Vol. XII., Nos. 89, 90. 8vo. London, 1890.  
*John Thornton*  
 Tryon, H., Report on Insect and Fungus Pests. No. 1. 8vo. Brisbane, 1889.  
*Trustees Queensland Mus.*  
 WEIN, Dr. E., Agriculturchemische Analyse. 8vo. Stuttgart, 1889. *Purchased*  
 Wilckens, Prof. M., Nordamerikanische Landwirtschaft. 8vo. Tübingen, 1890.  
*Author*  
 Wright, John, Profitable Fruit-Growing for Cottagers and Small Holders of  
 Land. 8vo. London, 1889 ..... *Author*  
 Wynne, Brian, Our Hardy Fruits: A Practical Guide to their Cultivation, &c.  
 8vo. London, 1890 .....*Author*  
 YOUNG, Arthur, Travels in France during the years 1787-9. With an Intro-  
 duction, Biographical Sketch, and Notes by M. Betham-Edwards.  
 2nd. Ed. 8vo. London, 1889 .....*Publishers (George Bell & Sons)*  
 ZEITSCHRIFT für Analytische Chemie. Jahrgang XXIX. 8vo. Wiesbaden,  
 1890.....*Purchased*  
 .. des landwirthschaftlichen Vereins in Bayern. Jahrgang LXXIX.  
 8vo. Munich, 1889.....*Verein*

---

*The Society is indebted to numerous Government Departments, both at home and abroad, to Boards of Agriculture, Agricultural Societies, and kindred institutions, for copies of their Annual Reports, Journals, Proceedings, Transactions, Bulletins, and other documents received regularly for the Library in exchange for copies of the Journal, as well as to the Editors of many agricultural and general papers for the current numbers of their publications, which have been placed for reference in the Reading Room.*

---

# ROYAL AGRICULTURAL SOCIETY OF ENGLAND.

## Proceedings of the Council.

WEDNESDAY, APRIL 8, 1891.

THE EARL OF RAVENSWORTH (PRESIDENT) IN THE CHAIR.

### Present:—

*Trustees.*—Earl Cathcart, Col. Sir Nigel Kingscote, K.C.B., Sir A. K. Macdonald, Bart., Duke of Richmond and Gordon, K.G.

*Vice-Presidents.*—Earl of Feversham, Lord Moreton, Sir John Thorold, Bart., Mr. C. Whitehead.

*Other Members of Council.*—Mr. G. M. Allender, Mr. J. Bowen-Jones, Mr. J. A. Caird, Mr. Chandos-Pole-Gell, Mr. Charles Clay, Earl of Coventry, Mr. Alfred Darby, Mr. C. De L. F. De Laune, Viscount Emlyn, Mr. William Frankish, Mr. James Hornsby, Mr. Charles Howard, Mr. Joseph Martin, Mr. T. H. Miller, Mr. P. A. Muntz, M.P., Hon. Cecil T. Parker, Mr. Albert Pell, Mr. J. E. Ransome, Mr. S. Rowlandson, Mr. A. J. Smith, Mr. Henry Smith, Mr. Martin J. Sutton, Mr. Garrett Taylor, Mr. J. P. Terry, Mr. John Tremayne, Mr. R. A. Warren, Mr. E. V. V. Wheeler, Mr. C. W. Wilson, Sir Jacob Wilson.

Professor Brown, C.B.

*Officers.*—Mr. Ernest Clarke, Secretary and Editor; Professor Simonds, Consulting Veterinary Surgeon; Dr. J. Augustus Voelcker, Consulting Chemist; Mr. Wilson Bennison, Surveyor.

The following members of the Doncaster Local Committee were also present:—The Mayor of Doncaster (Mr. Alderman Stockil), Mr. F. Bacon Frank, Mr. Joseph Firth Clark, Mr. John White, Mr. G. T. Wood, and

Mr. George Chafer (Secretary of the Local Committee).

### Apologies for Non-attendance.

Apologies for non-attendance were received from H.R.H. Prince Christian, K.G., Mr. Ashworth, Mr. Goringe, Mr. Mainwaring, Mr. Scarth, and Mr. Stanyforth.

### Election of New Members.

The minutes of the Council held on March 4 last having been read and confirmed, the election of the following eighty-eight Members was proceeded with:—

ALDAM, H. . . Bonbusk, Cuckney Mansfield.  
ALLEN, T. . . Manghold, Isle of Man.  
ARCHER, H. . . Drax Abbey, Selby, Yorks.  
AUCKLAND, E. . . St. George's Terr., Doncaster.  
BAKER, E. W. . . 23 Cattle Market, Norwich.  
BARTON, B. F. . . Burley, Woolton Hill, Newbury, Hants.  
BATHER, Major T. J. A. . . Great Ness, Salop.  
BLAKE, G. . . Chittern All Saints, Codford, Wilts.  
BOLSOVER, Lady. . . St. Ann's Hill, Chertsey.  
BOSTOCK, H. . . Walton Heath, Epsom.  
BRIGGS, A. . . Charleot, Bedale, Yorks.  
BRODIE, F. G. . . 51 Port Street, Evesham.  
BROWN, A. . . Tyldesley, Manchester.  
BURSTALL, Capt. J. H. . . Hesse Mount, Hull.  
CHAMBERS, Ambrose. . . Selby, Yorks.  
CHAMBERS, A. M. . . Tapton Lodge, Sheffield.  
CLARKE, C. B. . . Clayhidon, Wellington, Som.  
COCKILL, H. . . Green House, Doncaster.  
CROSLAND, B. . . Richmond, Handsworth, Yorks.  
DAWSON, C. . . Lake Road, Landport.  
DODSON, W., jun. . . Sprotbro', Doncaster.  
DUNKERLEY, C. C. . . Hurst Dale, Dunham Massey, Cheshire.  
DUTTON, B. . . Baddiley Farm, Nantwich.  
ELMHURST, H. I. . . Round Green, Barnsley.  
ELMHURST, J. . . Thorne, Doncaster.  
EXETER, Marquis of. . . Burghley Ho., Stamford.  
FAWCETT, H. . . Belthorpe, near York.  
FAWCETT, W. . . 105 Kirkstall Rd., Leeds.  
FERNLEY, G. A. . . Westwood, Buxton.  
FORRINGTON, J. T. . . Saxilby, Lincoln.

FOX, Samsöth. Grove House, Harrogate.  
 FRESTON, T. A. Eastwell Hall, Melton Mowbray.  
 GIBSON, E. Bally, near Doncaster.  
 GILLOTT, John. Conisborough, Yorks.  
 GREENWOOD, H. J. Birstwith Hall, Ripley, Leeds.  
 GROCOIT, T. Eddleston Hall, Nantwich.  
 HALIFAX, Viscount. Hickleton Hall, Doncaster.  
 HALL, S. M. Thorpe Salvin, Yorks.  
 HARRIS, H. F. Brooke House, Fleet, Hants.  
 HARRISON, F. King St., Thorne, Yorks.  
 HARWOOD, J. Fen End, Knowle, Birmingham.  
 HENDERSON, J. Castle Hill, Bickenhill, Birmingham.  
 HERVEY, J. P. S. Dry Hill Park, Tonbridge.  
 HULL, W. Carlton, Barnsley.  
 HOLTRY, W. Rotsea Manor, Cranswick, York.  
 HORBERRY, T. Wakeringham, Gainsborough.  
 ISHAM, A. C. The Hollies, Clipston, Northants.  
 JACKSON, J. A. Tilworth Grange, Sutton-on-Hull.  
 JARVIS, J. M. The Springs, Ellesmere.  
 JARVIS, J. Tilstock Park, Whitechurch, Salop.  
 JESSOP, W. de B. Overton Hall, Ashover.  
 JOHNSON, J. W. Riplingham Grange, Brough.  
 KING, G. Elliotts, Penshurst, Kent.  
 KINROSS, J. Sheepy, Atherstone.  
 LANXON, W. Demense, Lostwithiel.  
 MAUD, G. Thorne, Yorks.  
 MAY, W. A. Oakfield, Carshalton Hill.  
 MILLER, J. J. W. Hatfield House, Herts.  
 MURFIN, H. G. Urswick, Ulverston.  
 NICHOLSON, B. Wath-upon-Dearne, Yorks.  
 PARSON, J. J. Coombe Farm, Croydon.  
 PELHAM-CLINTON-HOPE, Lord H. F. H. The Deepdene, Dorking.  
 POSKITT, W. H. Birkin, Ferrybridge, Yorks.  
 PRATT, P. P. Brynllithbrig Hall, St. Asaph.  
 RADLEY, G. W. Conisbro', Rotherham.  
 RAINE, F. Little Hutton, Winston, Darlington.  
 RICHARDS, J. Llyncllys, Oswestry.  
 ROBINS, John. The Asps, Warwick.  
 ROOTH, John. Douglas, Isle of Man.  
 SALMON, W. May. Throapham, Rotherham.  
 SCHOLEY, T. C. Eastoft Grange, Goole.  
 SCRIVENER, E. B. L. Sibton Abbey, Suffolk.  
 SHORES, J. Owston Ferry, Rotherham.  
 SITWELL, E. S. W. Horsley, Derby.  
 SMITH, J. Blakelands, Bobbington, Stourbridge.  
 SNOWDEN, W. C. P. Hutton Moor, Thirsk.  
 SOLOMON, F. Barnard Castle.  
 SPEAR, J. R. Morthen, Rotherham.  
 STORR, J. Upper Morton Grange, Retford.  
 SWENDEN, J. Great Smeaton, Northallerton.  
 TAYLOR, A. Woodhall, Womersley, Pontefract.  
 TAYLOR, T. Darrington, Pontefract.  
 THOMPSON, L. Stonnington, Sheffield.  
 VONDY, J. W. East Kimmeragh, Bride, Isle of Man.  
 WAILES, C. H. West Rounton, Yorks.  
 WILKINSON, W. Harthill, Kiveton Park, Sheffield.  
 WRAGG, T., jun. Loxley, Sheffield.  
 WRAGG, William N. Loxley, Sheffield.

The reports of the various Standing Committees were then presented and adopted as below:—

### Finance.

Sir NIGEL KINGSCOTE (Chairman) reported that the accounts for the

month of March, 1891, as certified by the Society's accountants, showed total receipts amounting to 2,548*l.* 18*s.* 4*d.*, and expenditure amounting to 2,075*l.* 5*s.* 4*d.* The balance at the bankers on March 31 was 6,089*l.* 19*s.* 11*d.* Accounts amounting in all to 2,556*l.* 2*s.* 1*d.* were passed, and were recommended for payment. The quarterly statements (1) of subscriptions and arrears, and (2) of the Society's property, were laid upon the table. The Committee recommended that the names of one governor, six life members, and twenty-seven annual members deceased, one governor and twenty-nine members who had resigned, eight members whose addresses could not be found, and thirteen members in arrears of subscription, be struck off the register.

Sir NIGEL KINGSCOTE further reported that the Committee had again carefully considered the question of the limitation of the Society's prize-sheet for stock and produce, as to which they had submitted repeated recommendations in the past. They desired to refer to their Memorandum on the subject presented to Sir John Thorold's Committee on February 1, 1888, and to again express their adherence to their resolution of December 12, 1883, that in future the limit of 3,500*l.* for prizes for live-stock should not be exceeded. They thought that an additional sum of 500*l.* should be sufficient for the poultry and produce classes in the prize-sheet. In view of the large and increasing claims upon the Society's resources for other important agricultural objects, the Committee felt that they could not properly assent to a sum greater than 4,000*l.* being placed at the disposal of the Stock Prizes Committee for prizes for stock, poultry, and produce at the annual country meetings.

### Presentation of a Portrait of Jethro Tull.

The SECRETARY read a letter from Mr. Martin J. Sulton, offering for the acceptance of the Society the original painting of Jethro Tull, which had been reproduced as a frontispiece to Earl Cathcart's memoir of Tull, appearing in the current number of the Journal. Mr. Sulton added that this

painting was supposed to be the only portrait in existence of that celebrated agriculturist. The picture was sold by Mr. John Richards, F.S.A., on his leaving Reading forty-five years ago, to Mr. John Snare, the principal bookseller and publisher of Reading, and its authenticity as a portrait of Tull was vouched for by the eminent Mr. Cuthbert Johnson, F.R.S. On the death of Mr. Snare the picture passed into the possession of his widow, from whom he (Mr. Sutton) had purchased it.

Earl CATHCART moved that a cordial vote of thanks be given to Mr. Sutton for this valuable gift. As he was interested in the matter, he had been desired to say how much obliged the Society and the Council were to Mr. Sutton. Mr. Sutton had been most liberal on this occasion, and he must say patriotic, because he desired to safeguard the portrait of one who in all probability had done more for British agriculture than any other man that ever lived. He was sure that the Council would join with him in a grateful expression of thanks for Mr. Sutton's gift.

Sir NIGEL KINGSCOTE, as Chairman of the House Committee, seconded the motion, which was carried unanimously.

Mr. SUTTON thanked the Council for the very kind way in which they had received the picture he had had the good fortune to ask them to accept. Lord Cathcart had been, as usual, far too kind. The fact was that the picture would not have been there but for his Lordship's paper appearing in the Journal. The thought which arose in his Lordship's mind, that Jethro Tull ought to be commemorated in their Journal, had brought about the discovery of the portrait. Some had thought that, as Tull was a Berkshire worthy, the picture ought to be in the Berkshire Museum. But Tull was not a local or provincial character: his work had been of national use in agriculture, and the home of their great national society was, he (Mr. Sutton) thought, the proper place for the portrait. He was very glad that all the members of the Council thought so too, and it was a very great honour

for him to have helped in the discovery of the picture, and to have presented it to the Society. (Cheers.)

**House.**

Sir NIGEL KINGSCOTE (Chairman) presented various accounts for payment in connection with the house. The Organising Committee of the International Congress of Hygiene, to be held in London next August, having asked whether the Society would be willing to place its Council Chamber at the disposal of the Congress for the deliberation of one of the sections, the Committee recommended that this request be complied with.

**Journal.**

Earl CATHCART (Chairman) reported that the first part of Vol. II. of the Journal had been published on March 31, and was now in course of distribution to members. The Committee had referred to the Finance Committee various payments in respect of the printing and postage of, and literary contributions to, that number. An application by the Dowager Duchess of Bedford for permission to reprint, in a volume of memorials of the late Duke, the Editor's article on "Agriculture and the House of Russell" in the last number of the Journal, had been readily acceded to. The Committee recommended that the offer of the Secretary of the British Beekeepers' Association to send regularly to the Society's reading-room the "British Bee Journal" and the "Beekeepers' Record," be accepted with thanks. The arrangements for the next number of the Journal had been discussed, and directions given thereon.

Earl CATHCART, in reference to the letter from the Dowager Duchess of Bedford, said the Committee thought it very satisfactory that the Editor's paper was so highly appreciated by the family, as it deserved to be appreciated generally.

He had to proffer a request which was so often made, viz., that they would be very much obliged if members of Council and members of the Society would kindly suggest subjects

suitable for treatment in the Journal, and also send short contributions on farming practice for the "Notes" section of the Journal.

#### Chemical.

Viscount EMLYN (Chairman) reported that Dr. Voelcker had laid before the Committee, in anticipation of the next quarterly report, two cases of gross fraud—one in which oat-husks had been offered at 4*l.* a ton, and the other in which a so-called "improving meal," sold at 4*l.* 10*s.* a ton, was found to consist merely of sulphate of lime (gypsum). Various questions arising out of correspondence in the Chemical Department had been discussed, and directions given thereon. The Committee thought it right to call the attention of the Council to a letter addressed to Dr. Voelcker by the Secretary of State for India, in which Lord Cross expressed his satisfaction that the Government of India had cordially acknowledged the character and value of Dr. Voelcker's work during his deputation to India, and enclosed the following extract from their letter on the subject:—

We desire, in conclusion, to express our satisfaction with the manner in which Dr. Voelcker has accomplished his difficult mission. The intelligence, zeal, energy and patience with which he has conducted his inquiries and investigations have fully justified your Lordship's selection of him for the task which he has so well performed, and we are satisfied that his suggestions and recommendations will prove of considerable service to our local governments and administrations, as well as to ourselves.

Lord EMLYN added that the Committee were sure that the Council would share with them the satisfaction which they felt that Dr. Voelcker's services had received such deserved recognition.

Lord EMLYN also presented the report of the Woburn Sub-Committee, which announced the conclusion of the sheep-feeding experiments and the approaching termination of the bullock-feeding experiments.

#### Seeds and Plant Diseases.

Mr. WHITEHEAD (Chairman) reported that the diagrams of the wheat plant, after Bauer, and the diagrams of pasture grasses, were in process of execution. The Secretary had been instructed to communicate with the Warwick Local Committee, asking them, in dealing with the question of farm prizes in connection with the Warwick Meeting of 1892, to consider the advisability of offering prizes for fruit farms. A reference had been considered from the Woburn Sub-Committee as to the failure of alsike, red clover, cow grass, *Poa pratensis*, and *Poa trivialis* in the clover and grass experiments at Woburn. The Committee recommended that the plots should be re-sown with these clovers and grasses.

#### Veterinary.

Sir JOHN THOROLD (Chairman) reported that courses of lectures on horse-shoeing by Professor Pritchard had been arranged, under the auspices of the Worshipful Company of Farriers, to be held this month at the People's Palace, Regent Street Polytechnic, and the Royal Veterinary College. The Committee recommended that the resignation of Mr. G. Lewis, M.R.C.V.S., of his office of Provincial Veterinary Surgeon for the county of Monmouth, be accepted with regret. They proposed that out of the sum unexpended of their grant for 1891, 50*l.* be given towards the expenses of the International Congress of Hygiene, which had a section specially devoted to the relations of the diseases of animals to those of man.

Professor Brown had presented the following report:—

PLEURO - PNEUMONIA. — During the five weeks ended March 28 seventeen fresh outbreaks of this disease have occurred in Great Britain: eleven of them in England, in the counties of Bucks, Chester, Lancaster, London, Salop, Warwick, and York (West Riding); and six in Scotland, in the counties of Aberdeen and Edinburgh. In connection with these outbreaks forty-three diseased animals were killed, and 635 healthy cattle which had been



exposed to the risk of infection were also slaughtered.

In Ireland, seventeen fresh outbreaks of pleuro-pneumonia occurred in the Dublin district, the majority of them in the South Dublin Union; twenty-seven diseased cattle were killed, and 500 healthy ones, which had been in contact, were also slaughtered.

**ANTHRAX.**—There were twenty-eight fresh outbreaks of anthrax reported in Great Britain during the five weeks, in the counties of Chester, Cumberland, Devon, Essex, Hants, Lancaster, Lincoln (Kesteven), Norfolk, Northampton, Notts, Rutland, Stafford, Suffolk, Wilts, Worcester, York (North Riding), York (West Riding), Ayr, and Wigtown. In these outbreaks fifty-five animals were attacked, four diseased animals were killed, thirty-seven died, and ten recovered.

**SWINE-FEVER.**—In Great Britain 424 fresh outbreaks of this disease occurred, 2,119 swine were attacked, 917 diseased pigs were killed, 811 died, 180 recovered, and 371 remained alive when the last return was made up.

**RABIES.**—There were four cases of rabies reported in England in the five weeks; three of these were in Lancashire, and one in Dorset.

**FOOT-ROT IN SHEEP.**—Experiments having reference to the communication of foot-rot from diseased to healthy sheep were continued during last autumn and winter. Two diseased sheep were placed on grass land at the Royal Veterinary College, and three healthy sheep from a different part of the country were penned with them for several months, with the result that the diseased sheep recovered and the others remained healthy.

Further experiments are now being made. Two sheep affected with what is considered to be the typical form of the contagious disease were presented to the College by Mr. Whitehead. Another sheep with well-marked foot-rot was obtained from the neighbourhood of Harrow. The two diseased sheep from Kent have been penned since the middle of March with a healthy sheep from Harrow, and on

April 4 three half-bred tegs from Berkshire, from a flock which was free from foot-rot, were added to the pen. The diseased sheep from Harrow is penned in another part of the same meadow with a healthy sheep obtained from the same district. All the animals are under constant observation.

#### Stock Prizes.

Mr. FRANKISH reported that various letters respecting entries for the Doncaster Meeting had been considered, and directions given thereon. The Committee recommended that a special meeting be held next month to consider a preliminary prize-sheet for the Warwick (1892) Meeting.

#### Judges' Selection.

Mr. FRANKISH also reported that the list of Judges for the Society's Doncaster Meeting was now practically complete.

#### Implement.

Mr. FRANKISH (Chairman) reported that about 12,000 feet of space had been applied for in the Implement Department at the Doncaster Meeting, and that the Allotment Committee at a preliminary meeting had given directions as to the various points arising out of the entries. Several questions in connection with the trials of threshing machines at the forthcoming Meeting at Doncaster had been discussed and settled. The Committee, having further considered the regulations for the trials of ploughs at the Warwick Meeting, a draft of which had been previously sent to each member of the Council, now submitted for the formal approval of the Council the following proposed prize-sheet and regulations:—

#### Warwick Meeting, 1892. Prizes for Ploughs.

Class.	Prizes.	
	1st	2nd
	£	£
1. For the best single-furrow plough for light land . . . . .	10	5
2. For the best single-furrow plough for strong land . . . . .	10	5
3. For the single-furrow plough best adapted for a press drill and broadcast sowing . . . . .	10	5
4. For the best two-furrow plough . . . . .	10	5

Class.	Prizes.	
	1st	2nd
	£	£
5. For the best three-furrow plough	10	5
6. For the best digging plough for light land	10	5
7. For the best digging plough for heavy land	10	5
8. For the best one-way plough	10	5

**REGULATIONS.**

1. The trials will take place early in the spring of 1892, on land selected by the Society, in the neighbourhood of Warwick.

2. The necessary arrangements for the land required for the trials will be made by the Society.

3. Notice of the place and date of the trials will be posted to every competitor as soon as they are fixed.

4. All ploughs for competition must be delivered at the depot of the trial-shed not less than three days previous to the commencement of the trials, or they will be disqualified.

5. Each competitor or his representative will be allowed to accompany the ploughman, and assist him in any way he may require.

6. The order in which the several ploughs will be tested will be determined by the stewards, who will decide by lot.

7. No competitor will be allowed to enter more than two ploughs for competition in any one class.

8. The points representing perfection will be as under:—

*Single-Furrow Ploughs (Classes 1 to 3).*

Price	10
Mechanical qualities and strength	20
Simplicity	10
Draught relatively to work done	20
*Flatness of sole of furrow	10
Squareness of cut on land side	5
Perfection of working and burying vegetation	20
Efficiency of skim coulter	5
<b>Total</b>	<b>100</b>

*Two and Three-Furrow Ploughs (Classes 4 and 5).*

Price	10
Mechanical qualities and strength	20
Simplicity	10
Draught relatively to work done	20
Ease of management in work and in turning	15
Facilities of transport	5
Flatness of sole of furrow	10
Squareness of cut on land side	5

\* This will not be considered in the case of entries in Class 3.

Perfection of work and burying vegetation	20
Efficiency of skim coulter	5
<b>Total</b>	<b>120</b>

*Digging Ploughs (Classes 6 and 7).*

Price	10
Mechanical qualities and strength	20
Simplicity	10
Draught relatively to work done	20
Flatness of sole of furrow	10
† Perfection of work and burying vegetation	25
Efficiency of skim coulter	5
<b>Total</b>	<b>100</b>

9. The ploughs entered for competition will, after the trials, be retained in the possession of the Society until the Warwick Meeting, when they will all be exhibited together in the showyard in a space set apart by the Society for the purpose.

10. Entries for the prizes must be made on or before Saturday, July 25, 1891, and must be accompanied by a deposit at the rate of 1*l.* for each plough entered. This deposit will be forfeited if the plough is not forthcoming at the time appointed for the commencement of the trials, but will in other cases be refunded after the Warwick Meeting.

NOTE.—Should the Judges find any number of exhibits to be of practically equal merit, they are empowered to bracket them as equal, and so divide the prize-money.

On the motion of Mr. FRANKISH, seconded by Mr. MARTIN, these regulations were approved, and ordered to be issued forthwith.

**General Doncaster.**

The Earl of FEVERSHAM reported that the preliminary programme of the Doncaster Meeting prepared by the Secretary had been considered and provisionally approved. Arrangements were in progress for the establishment of an ambulance station in the showyard, and for retaining the services of a detachment of the A Division of the Metropolitan Police. The Local Committee had recommended Messrs. Hodgson & Hepworth and Messrs. Sanderson & Stringer, of Doncaster, as agents for the sale of cheese which exhibitors

† Perfection of work to be: to make a good seed bed; to do work best adapted for the purposes of winter fallow.

might desire to dispose of after the Meeting. Various other matters connected with the Meeting had been discussed and dealt with.

### Showyard Works.

Sir JACOB WILSON (Chairman) reported that the showyard at Doncaster was inclosed with a high fence, and the entrances had been erected. About 5,000 feet of shedding had been built, and the grand stand, dairy, and refreshment rooms were also in the course of erection. The Local Committee were laying the water and gas mains, had completed the sleeper road, and were levelling and rolling some rough places in the yard. The Committee had considered the tenders received for the supply of refreshments at Doncaster, and recommended the following for acceptance:—

Shed No. 1 . . .	Samuel Foster, Newark.
Shed No. 2 . . .	A. E. Brayshay, Leeds.
Shed No. 3 . . .	Bourne & Co., Dudley.
Shed No. 4 . . .	John Potter, Malton.
Shed No. 5 . . .	Bodega Co., Limited.
Shed No. 6 . . .	Alex. Stott, York.
Shed No. 7 . . .	John Potter, Malton.
Shed No. 8 . . .	Samuel Foster, Newark.

A letter had been received from the National Telephone Co., Limited, offering to provide telephonic communication in the showyard, on the condition that the Society granted the Company permission to have a central call office in the showyard. The Committee recommended the acceptance of this offer. They also recommended the appointment of Mr. Walker, of York, as auctioneer for the sale of timber after the show.

### Selection.

Earl CATHCART (Chairman) presented the recommendation of the Committee as to a new member of Council to fill the vacancy caused by the resignation of the Earl of Jersey; and also their recommendation that Earl Cathcart be asked to accept the post of Steward of Horses for the Doncaster Meeting, in the place of Lord Moreton, retired.

Sir JACOB WILSON said that their present Steward, Lord Moreton, found that he would be unable to perform the duties of Steward of Horses at Doncaster, and it was necessary to elect in his place someone who had had experience of the work, rather than appoint a fresh Steward for the

purpose. Seeing that Lord Cathcart took a very prominent part in bringing the question of horse-breeding before the country some years ago, which resulted in a great increase of interest in this subject, and noticing especially that they were going to Yorkshire, it was felt that they would be doing that which would be most agreeable to the locality, and certainly that which would be agreeable to the Council, in asking his Lordship to undertake the duties of Senior Steward of Stock.

Earl CATHCART was obliged to explain that he might possibly be wanted in town part of the time of the show, but, subject to that, he would try to undertake the duties.

### Education.

Mr. WHEELER reported that twenty-one candidates had entered for the Senior Examination, to take place in the week commencing May 12 next. The Sub-Committee on Agricultural Text-Books had made further progress with the proposed text-book for use in elementary and continuation schools sanctioned at the last meeting of the Council, and had settled the plan of the work. Copies had been received of the Report of the Cambridge Agricultural Education Syndicate, which it was proposed to circulate amongst members of the Council for their information. The general question of technical education in agriculture had been again discussed, and it had been resolved to reprint Dr. Fream's article on the subject appearing in the last number of the Journal, together with the two reports of the Education Committee dated November 4 and March 3 last, and to send copies of the reprint to each County Council for the information of their Education Committees.

### Dairy.

The Hon. CECIL T. PARKER (Chairman) reported that the arrangements made by the Secretary for the hire of dairy utensils at Doncaster had been submitted and approved. A further letter had been received from the Board of Agriculture on the subject of examinations in dairying, and the Committee had requested their Chairman to represent the Society in a proposed interview with officials of the Board.

Mr. PARKER added that he had that morning, by appointment, paid a visit to the offices of the Board of Agriculture, and had discussed the question with the Board's officials.

### Retiring Members of Council.

The annexed list was prepared of the members of Council who retire by rotation, but are eligible for re-election, showing the number of attendances at Council and Committee Meetings of each of such members during the past two years, in accordance with Bye-Law No. 23:—

Attendances at Meetings of Council and Committees from April 1889 to March 1891 inclusive	Council Meetings Total Number, 20	Committees	
		No. of Meetings	Attendances
ALLENDER, G. MANDER, 31 St. Petersburg Place, Bayswater . . .	15	117	70
ASHWORTH, ALFRED, Tabley Grange, Knutsford, Cheshire . . .	10	108	44
EOWEN-JONES, J., Emsdon House, Montford Bridge, Salop . . . . .	16	135	81
CAIRD, JAMES A., Northbrook, Micheldever, Hants . . . . .	16	114	81
CHANDOS-POLE-GELL, H., Hopton Hall, Wirksworth, Derbyshire . . . . .	11	59	31
COVENTRY, Earl of, Croome Court, Severn Stoke, Worcestershire . . . . .	13	49	5
CRUTCHLEY, PERCY E., Sunninghill Park, Berkshire . . . . .	18	50	29
DARBY, ALFRED, Little Ness, Shrewsbury . . . . .	12	63	29
DE LAUNE, C. DE L. Faunce, Sharsted Court, Sittingbourne, Kent . . . . .	12	89	52
GORRINGE, HUGH, Kingston - by - Sea, Brighton, Sussex . . . . .	9	66	14
HAMOND, ANTHONY (elected May 1, 1889), Westacre, Swaffham, Norfolk . . . . .	9	23	9
HOWARD, CHARLES, Biddenham, Bedford . . . . .	10	108	65
MAINWARING, C. S., Gallfaenan, Trefnant R.S.O., North Wales . . . . .	14	88	48
MARTIN, JOSEPH, Highfield House, Littleport, Isle of Ely, Cambs . . . . .	11	53	14
MILLER, T. HORROCKS, Singleton Park, Poulton-le-Fylde, Lancashire . . . . .	13	51	19

Attendances at Meetings of Council and Committees from April 1889 to March 1891 inclusive	Council Meetings, Total Number, 20	Committees	
		No. of Meetings	Attendances
PARKER, Hon. CECIL T., Eccleston, Chester . . . . .	16	119	70
PELL, ALBERT, Hazlebeach, Northampton . . . . .	13	96	60
ROWLANDSON, SAMUEL (elected May 22, 1889), Newton Morrell, Darlington (Yorkshire) . . . . .	11	42	17
SCARTH, W. T., Staindrop House, Darlington, Durham . . . . .	8	17	—
SMITH, ALFRED J., Rendlesham, Woodbridge, Suffolk . . . . .	17	66	43
STANYFORTH, E. WILFRID (elected February 4, 1891), Kirk Hammerton Hall, York . . . . .	1	—	—
TAYLOR, GARRETT (elected May 22, 1889), Trowse House, Norwich . . . . .	11	37	12
TERRY, JOS. P. (elected April 2, 1890), Berry Field, Aylesbury, Buckinghamshire . . . . .	7	13	7
WILSON, C. W. (elected May 22, 1889), Rigmaden Park, Kirkby Lonsdale, Westmoreland . . . . .	12	47	34
WILSON, Sir JACOB, Chillingham Barns, Belford, Northumberland . . . . .	19	127	85

### International Agricultural Congress at the Hague.

The SECRETARY submitted various documents connected with this Congress, which is to be held at the Hague from September 7 to 12 next, including letters of thanks from the President (M. Bauduin) and the Secretary (M. Zillesen) for the assistance rendered by the Society in making the arrangements for the Congress known in this country.

### Miscellaneous.

The agreement for the holding of the Country Meeting of 1892, sealed with the seal of the Corporation of Warwick, was laid upon the table, together with correspondence with the Mansion House United Association on Railway Rates.

Other formal business having been transacted, the Council adjourned until Wednesday, May 6 next.

WEDNESDAY, MAY 6, 1891.

THE EARL OF RAVENSWORTH (PRESIDENT) IN THE CHAIR.

Present:—

*Trustees.*—H.R.H. the Prince of Wales, K.G., General Viscount Bridport, K.C.B., Earl Cathcart, Mr. John Dent Dent, Lord Egerton of Tatton, Col. Sir Nigel Kingscote, K.C.B.

*Vice-Presidents.*—Right Hon. Sir Massey Lopes, Bart., Lord Moreton, Earl Spencer, K.G., Mr. C. Whitehead.

*Other Members of Council.*—Mr. G. M. Allender, Mr. J. H. Arkwright, Mr. Alfred Ashworth, Mr. Joseph Beach, Mr. J. Bowen-Jones, Lord Brougham and Vaux, Mr. J. A. Caird, Mr. Chandos-Pole-Gell, Mr. Charles Clay, Mr. Percy E. Crutchley, Mr. Alfred Darby, Mr. C. De L. F. De Laune, Mr. S. P. Foster, Mr. William Frankish, Mr. Hugh Gorrings, Mr. R. Neville Grenville, Mr. James Hornsby, Mr. Charles Howard, Mr. C. S. Mainwaring, Mr. Joseph Martin, Mr. T. H. Miller, Hon. Cecil T. Parker, Mr. Albert Pell, Mr. Daniel Pidgeon, Duke of Portland, Mr. J. E. Ransome, Mr. G. H. Sanday, Mr. W. T. Scarth, Mr. A. J. Smith, Mr. Henry Smith, Sir Joseph Spearman, Bart., Marquis of Stafford, Mr. E. W. Stanyforth, Mr. Richard Stratton, Mr. Martin J. Sutton, Mr. Garrett Taylor, Mr. J. P. Terry, Mr. John Tremayne, Mr. R. A. Warren, Mr. E. V. V. Wheeler, Mr. C. W. Wilson, Sir Jacob Wilson.

*Officers.*—Mr. Ernest Clarke, Secretary and Editor; Dr. J. Augustus Voelcker, Consulting Chemist; Mr. Wilson Bennison, Surveyor.

The following members of the Doncaster Local Committee were also present: The Mayor of Doncaster (Mr. Alderman Stockil), Mr. F. Bacon Frank, Mr. John White, Mr. G. T. Wood, Mr. G. B. C. Yarborough, and Mr. George Chafer (Secretary of the Local Committee).

#### Apologies for Non-attendance.

The PRESIDENT announced that apologies for non-attendance had been received from H.R.H. Prince Christian,

K.G., the Duke of Richmond and Gordon, K.G., the Earl of Feversham, Viscount Emlyn, Right Hon. Henry Chaplin, M.P., Sir Matthew Ridley, Bart., Sir John Thorold, Bart., and Mr. Walter Gilbey.

#### Election of Governors and Members.

The minutes of the Council held on April 8 last having been read and confirmed, the election of the following 111 Members was proceeded with:—

APPLEYARD, Henry..Barby Bank, Selby.  
 ARCOLL, C. S...Lime Park, Hurstmonceaux.  
 ARMSTRONG, John..Penrith.  
 ARTER, A. C...Barham, near Canterbury.  
 BADDILEY, J. E...The Norna, Blyth, Rotherham.  
 BAILEY, Joseph..Holly Ho., Scaftworth, Bawtry.  
 BARKER, G...Burn, near Selby.  
 BATT, Miss R. E...Angus and Mearns' Dairy School, Kirriemuir, N.B.  
 BAYLIS, Arthur B...Rotherham.  
 BEDDINGTON, H. E...15 Hyde Park Square, W.  
 BELL, H. C...The Deepdene, Dorking.  
 BELLAMY, G...Clap Gate Farm, Thorne, Yorks.  
 BELTON, E...Tadworth, Thorne, Doncaster.  
 BEST, T. W...Harvest Hill, Cuckfield.  
 BETTERIDGE, H. D...Wallingford.  
 BIRKETT, T. B...9 Park Place, Weston-s-Mare.  
 BOOTH, S...Cresswell, Mansfield.  
 BROWN, T...Hempstead, Hailsham.  
 BROWN, T...Harworth Grange, Tickhill.  
 BUTSON, Col. W. E...Coxlease, Stonor, Henley-on-Thames.  
 CADELL, G...14 Canning Road, Addiscombe.  
 CALVERT, F...Ashton Park, Preston.  
 CAMERON, C. St. Clair..St. John's Ho., Lichfield.  
 CAMPBELL, Rev. J...Laleham, Randwick, Sydney, New South Wales.  
 CHALMERS, J. A...Laurel Farm, Felixstow.  
 CHAMBERS, J...Normanton Inn Farm, Worksop.  
 CHAPLIN, F. J...Fulbourn, Cambs.  
 CHILLINGWORTH, S. S...Forton, Hartlebury, Worcester.  
 CLARK, D. M...Anston, Rotherham.  
 CLARK, M. R...Harthill, Sheffield.  
 CLARK, M...Cusworth, Doncaster.  
 CLAY, G. A...Holly Bush Hall, Burton-on-T.  
 COX, G...Elmton Park, Chesterfield.  
 CRAVEN, T...Ashton-on-Mersey.  
 CRISP, F...White House, New Southgate, N.  
 CUSHNEY, A...Pain's Hill, Cobham.  
 DISRAELI, Coningsby..Hughenden Manor, High Wycombe.  
 DRINKALL, W...Heaton-with-Otcliff.  
 DUGDALE, W...Meeson Hall, Wellington, Salop.  
 DUNCAN, J. H. H...39 Coleman Street, E.C.  
 DUVAL, F. R...53 Rue François 1<sup>er</sup>, Paris.  
 EDGE, T. L. K...Grant House, Southwell.  
 EVERATT, J. J...Wildsworth, Gainsborough.  
 FOORD, T...Barton-on-Humber.  
 FRANKS, J. H...Dalriada, Blackrock, co. Dublin.

<sup>1</sup> Reinstated under Bye-Law 12,

GARNETT, J...The Grange, Bromley Cross, Bolton.  
 GIBSON, G...Fourstones, Northumberland.  
 GOODALL, T. B...Purewell Cross, Christchurch.  
 GOODWILL, J...North Ings, Terrington, York.  
 GRAMMER, J...Calverton, Nottingham.  
 GREENE, T...Millbrook, Mageny, co. Kildare.  
 GRIFFITHS, William...Oswestry.  
 HANDS, Sidney...Hampton Lucy, Warwick.  
 HARRISON, Wm...Leigh, Lancashire.  
 HUGHES, Gen...Dunley, Bovey Tracey.  
 JONES, S. E...8 Arkwright Rd., Hampstead.  
 KIDGER, E...Manton, Worksop.  
 LAWSON, H...Manor House, Skirpenbeck, Stamford Bridge, Yorks.  
 LEWIS, A. H...Marbury Hall, Northwich.  
 MAAS, H. S. J...40 Finsbury Circus, E.  
 MACHIN, H. V...Gateford Hill, Worksop.  
 MCMORRIN, J. T...Earls House, Durham.  
 MALLESON, P. R...Dixton, Winchcombe.  
 MARSHALL, J. W...Kirby Grindalythe, Yorks.  
 MILES, F. A...Denne Hill Farm, Canterbury.  
 MILNTHORP, James...Doncaster.  
 MITCHELL, Mrs. W. H...Eldmole, Kenilworth.  
 MORTON, J. A...Puxton Ho., Kidderminster.  
 MOUSLEY, T. E...Brockton Hall, Eccleshall.  
 NICHOLETTIS, J. T...Manor House, Brent Knoll, Somerset.  
 NICHOLSON, W...Brisley, Norfolk.  
 OGDEN, Tom P...Wimblington, March.  
 PARLOUR, Wm...Dalton-on-Tees, Darlington.  
 PATRICKSON, Hugh...Kirklington Park, Carlisle.  
 PETCH, John P...Liverton Lodge, Loftus.  
 PHILLIP, D. W...Whiteacre, Coleshill.  
 PRICE, T. S...Glencairn, Coventry Park, S.W.  
 PROTHERO, F. E...Malpas Ct., Newport, Mon.  
 RHODES, S...Prospect Ho., Morley, Leeds.  
 ROBERTS, S...Queen's Tower, Sheffield.  
 ROBERTS, T...41 Ranelagh St., Liverpool.  
 ROSE, John D...Great Stukeley, Huntingdon.  
 SANDBACH, S. H...Cherry Hill, Malpas.  
 SCRIVEN, J...Normandy Villa, Shipley.  
 SIMPSON, Wm...Daintree Ho., Ramsey.  
 SKELTON, J...Cothorpe, Worksop.  
 SMITH, J. H...37 St. George's Place, Barnsley.  
 STABLES, J...Hickleton, Doncaster.  
 STANDING, W...Chapel Street, Epworth.  
 STANFORD, Alan...Beaumont Hall, Colchester.  
 STEPHENS, J...19a Coleman Street, E.C.  
 STERICKER, F. H...Westgate Ho., Pickering.  
 STRICK, Col...Bar Hill Ho., Madeley, Staffs.  
 SWAN, Mrs. Emily...Stonefield, Lincoln.  
 TAYLOR, V. T...Middlewood Hall, Barnsley.  
 TEMPLE, J. W...Leyswood, Groombridge.  
 TENNANT, R...Kirkburn Grange, Driffield.  
 THOMPSON, F. M...Doncaster.  
 THURSTON, E. H...Pennal Towers, Machynlleth.  
 TRICKETT G. J...Crock Ho., Ardsley, Barnsley.  
 WALE, J. H...Burton Bandalls, Loughborough.  
 WESLEY, J...Grove Ho., Stretham, Ely.  
 WHEELER, H. C...Downton, Wilts.  
 WHIPP, W. W...Siddows Farm, Clitheroe.  
 WHITOMK, E...Ramsey, Huntingdon.  
 WILSON, D. de C...Wickersley Grange, Rotherham.  
 WOOD, B. D...Lytton House, Stevenage.  
 WOOD, Guy...The Lodge, Ardsley, Barnsley.  
 WOOD, W...Sookholme, Mansfield.  
 WOOLLEY, F...Amlerton, near Stafford.  
 WRAGO, F. W...17 Church Lane, E.

#### Nominations of New Members.

On the motion of Sir NIGEL KINGSCOTE, seconded by Lord BRIDPORT, it was unanimsly resolved:—

That the Secretary be authorised to receive nominations of members, and to admit them to the privileges of membership for the Doncaster Show, on condition that they sign the usual contract and pay their subscription for the current year.

The reports of the several Standing Committees were then presented and adopted as below:—

#### Finance.

Sir NIGEL KINGSCOTE (Chairman) reported that the accounts for the month of April, 1891, as certified by the Society's accountants, showed total receipts amounting to 4,201l. 2s., and an expenditure amounting to 2,599l. 7s. 1d. The balance at the bankers on April 30, allowing for cheques outstanding, was 7,691l. 14s. 10d. Accounts amounting in all to 2,387l. 3s. 5d. were passed, and were recommended for payment. The Committee recommended that Mr. Frankish and Mr. Sanday be appointed Stewards of Finance at the Doncaster Meeting. A letter addressed to the Council by the Mansion House United Association on Railway Rates, asking the Society to guarantee a sum of 500l. towards the expenditure which the Association is incurring in defending agricultural interests before the Joint Committee on the Railway Rates Provisional Order Bills, had been considered, and the Committee recommended that a further and final grant of 100l. (making 300l. in all) be made to the funds of the Association. The Committee recommended that the names of eight life members and sixteen annual members who were deceased, seven members who had resigned, ten whose addresses could not be found, and forty-three in arrears of subscription be struck off the register; also that two members be restored to the list under Bye-Law 12.

#### House.

Sir NIGEL KINGSCOTE (Chairman) reported that the picture of Jethro Tull, presented to the Society by Mr. Sutton, had been cleaned and the frame repaired, and that it was now hung up in the Council room. The question of the proposed increase in the assessment of the parish of St.

George, Hanover Square, had been considered; but the Committee did not recommend any action thereon at present.

**Journal.**

Earl CATHCART (Chairman) reported that the arrangements for the next number of the Journal had been discussed, and directions given thereon. Applications from the Royal Meteorological Society and Professor Simonds for permission to reprint articles from the Journal were granted under the usual conditions. A letter had been read from the Meteorological Office as to the results of the Hay Harvest Forecasts in 1890, and the summary of these results had been ordered to be published in the next number of the Journal.

**Chemical.**

Mr. PELL (in the absence of Viscount Emlyn, Chairman) presented the recommendations of this Committee as to correspondence arising in the Chemical Department. The Phoenix Oil Mills Co., Limited, of Liverpool, had expressed in a letter enclosing an advance copy of their circular their intention of selling linseed cake in future on the form of contract recommended by the Society. Satisfaction was expressed at this step taken in accordance with the Society's suggestion to agriculturists. Dr. Voelcker had mentioned to the Committee a case in which unsound decorticated cottonseed-meal was believed to have caused the death of twenty sheep. He had also brought to the notice of the Committee an instance of a so-called vine manure being supplied to a member of the Society at a price of 7*l.* per ton, which proved on analysis to be little more than ground-up flints and sulphate of lime.

On the motion of Mr. PELL, Mr. E. W. Stanyforth was added to the Committee.

**Seeds and Plant Diseases.**

Mr. WHITEHEAD (Chairman) presented a report from Miss Ormerod, which the Committee recommended should be published with the proceedings of Council (see page x). A letter had been read from the Board of

Agriculture, asking whether the Society was possessed of results of any experiments conducted in this country for the purpose of testing the efficacy of applications of sulphate of copper as a remedy against potato disease, and, if not, whether it would be feasible for the Society to undertake a series of specific experiments of this nature in four or five distinctive and typical parts of England, during the summer of 1891, and, if necessary, in succeeding seasons. It had been resolved to recommend that the answer of the Council should be that the Society considered such experiments feasible, and that it would be willing to organise and conduct them for the Board of Agriculture, if the Board should think it desirable. If this reply were approved by the Council, the Committee further recommended that their Chairman (Mr. Whitehead), Lord Moreton, Mr. De Laune, Mr. Carruthers, and Dr. Voelcker (with power to add to their number) be appointed a Sub-Committee to draw up a scheme, and to make the necessary provision for the conduct of any experiments that might be arranged in conjunction with the Board of Agriculture.

Mr. WHITEHEAD, in moving the adoption of the report, said he thought he should briefly allude to the important communication which had been received from the Board of Agriculture with regard to the conducting of experiments with sulphate of copper for the prevention of the potato disease. He sincerely trusted that the Council would entertain the proposition made by the Board, and allow such experiments to be conducted by the Sub-Committee recommended by the Seeds and Plant Diseases Committee, in conjunction with the Board of Agriculture. He ventured to think that this was one of the most important questions that had, recently at all events, been brought before that Council. It was a question of national concern. The Society had already instituted experiments in 1872, with regard to the prevention of, or the discovery of a remedy for, this fell disease, which had ravaged their potato crops in this country now for nearly fifty years, without

any check or remedy being found against it. He thought it was a question that should be investigated thoroughly and completely by that Society.

The remedy, as he ventured to think, had been found in this sulphate of copper treatment—*i.e.*, what was called in France "Bouillie Bordelaise," a solution of sulphate of copper mixed with lime and a certain proportion of water. In 1878 a new fungus made its appearance in the vineyards of France; not the ordinary *Oidium Tuckeri*, the fungus which had ravaged the vineyards for nearly fifty years, but another and much more serious disease, caused by *Peronospora viticola*, which was closely allied to *Peronospora infestans*, a fungus that caused the potato disease, which had been called by De Bary *Phytophthora infestans*. This remedy of sulphate of copper was found out in the most peculiar manner. It was customary in France to treat grapes growing by the road sides with sulphate of copper and lime to keep off pilferers and marauders, as grapes so treated would naturally not be pleasant. It was noticed that grapes treated in that way were free from this new vine fungus *Peronospora viticola*; and experiments were made with it in various parts of France. In 1886 M. Prillieux reported to the Société Nationale d'Agriculture de France that the sulphate of copper treatment was perfectly efficacious for the cure of vine mildew, and he recommended that the Bouillie Bordelaise mixture should be used in exactly the same way for the potato disease. Experiments since 1886 had been conducted in different parts of France, notably by M. Aimé Girard, for the last three years. The results of these experiments appeared in the "Annales Agronomiques," and in the Bulletins of the Société Nationale d'Agriculture de France. It was clearly shown that the treatment of sulphate of copper had been most efficacious as a preventive, and also, in some degree, as a cure for the potato disease when actually established upon the plants. There was no doubt that the mixture had proved a preventive against the disease, and when applied, as such,

no sign or trace of potato disease had been found. Similar experiments had been made in Belgium for the last two years at the State Agricultural Institute at Gembloux by M. Péterman, Director of that institution. The results of M. Péterman's experiments were equally satisfactory with those of M. Aimé Girard in France. He also arrived at the conclusion that sulphate of copper not only prevented and arrested the disease, but that sulphate of iron, which was a much cheaper mixture, was equally efficacious. No doubt there would be further reports upon this subject.

An experiment had also been tried in Ireland at the suggestion of the British Board of Agriculture, and although the directions to carry out these experiments in Ireland were given very late indeed, so that the application could not be made until the end of August, Mr. Carroll, who had carried out this experiment in five or six different parts of Ireland, reported that the effect was certainly satisfactory. Experiments had been carried out in America with similar satisfactory results. He trusted that the Council would allow the experiments to be made as suggested in the Committee's report. It was not likely that the cost of these experiments, which it was proposed should extend over three years, would exceed 300*l.* at the rate of 100*l.* a year. He wished to give notice that day that he should move at the next meeting of the Council that a grant of 300*l.* should be placed at the disposal of the Seeds and Plant Diseases Committee, if required by them, for the purpose of these experiments. The Seeds and Plant Diseases Committee believed that the Board of Agriculture might contribute a very considerable part of the expense, but he trusted that the Council would give their sanction to a money grant from the Society's funds, if it should prove requisite.

Earl CATHCART, as having had in former times a good deal to do with potato disease, seconded the adoption of this report. The subject had been brought before the House of Lords on Monday; it was then stated that experiments had been made with a view of curing this disease of the potato. The treatment was, how-



ever, in no sense a cure; it was prophylactic—fungicide, inasmuch as designed to destroy the spores which promote the disease. He wished to say for the Journal Committee that this was no new matter to them, for the subject was brought forward in the Journal in December of last year. The composition of the remedy known as "Bouillie Bordelaise" was given in the Society's Journal as 6 lb. of lime, 6 lb. of sulphate of copper (*i.e.*, common blue vitriol, the blue-stone of commerce), and ten gallons of water. It was said that this application must be repeated as occasion required. He had inquired as to the expense of the material; and found it given as from 17*l.* to 25*l.* per ton for the blue-stone.

Mr. ASHWORTH said that, as the mixture should be applied during the early growth of the potato, and as the matter was of the greatest interest, it seemed a pity to delay operations for a month. Could not the Sub-Committee be empowered to commence at once, without waiting for the passing of the grant at the next meeting of the Council?

Mr. WHITEHEAD said the treatment was mainly preventive, and should be applied as soon as the plants were about 2 ft. high. It was, therefore, of great importance that the question should be settled at once, and that action should be taken as soon as possible. This year, however, the potato plants were very late, and he thought that there would be no harm done if the matter were postponed until the next meeting of the Council, under the circumstances of the late season. As to the preventive or curative properties, there were proofs on both sides. It was undoubtedly preventive, and it might cure the fungus if it had not got to a certain stage. Most interesting experiments had been made by French chemists with regard to this, especially by M. Schlössing, who treated the leaves of the vine with sulphate of copper, as well as with the "Bouillie Bordelaise." He sowed germs of fungus upon the leaf so treated, and they did not germinate at all. He sowed some at the same time upon leaves not treated with sulphate of copper, and these germs

immediately or soon after germinated.

Mr. CHANDOS-POLE-GELL said that in 1888 he passed about three weeks during the early part of the vintage in the Médoc district, and had the opportunity of seeing the different vineyards. Nobody could have conceived the difference between those not treated, those partially done, and those well done. The difference between them was perfectly inconceivable. He had talked to a great many owners and managers of vineyards, who were strongly in favour of the remedy.

Earl CATHCART asked if the Board of Agriculture intended to circulate a leaflet on the subject.

Mr. WHITEHEAD replied that a leaflet was now in preparation, and would, he believed, be issued in a few days.

Mr. STRATTON suggested that leaflets with an epitome of the evidence which had been placed before them that day should be circulated with the next number of the Journal.

Sir NIGEL KINGSCOTE said that if it was only a question of finance that would stop the experiments, he thought he might say, on behalf of the Finance Committee, that they would not place any obstacle in the way.

Earl CATHCART said it was thought that the Board of Agriculture would contribute largely towards the expense.

The SECRETARY pointed out that if it were the unanimous wish of the Council to grant the money for the experiments, they had power under the bye-laws to vote it at once.

Mr. DENT then formally moved, Lord BROUGHAM and VAUX seconded, and it was unanimously resolved that a sum not exceeding 300*l.* should be placed at the disposal of the Seeds and Plant Diseases Committee, for the purpose of the experiments proposed.

The PRESIDENT said that it was a sufficient proof of the importance of the subject that questions had been asked in both Houses of Parliament, and that satisfactory answers had been given by Her Majesty's Ministers. He took the opportunity, in putting the motion for the adoption of the

report, and of the report of the Consulting Entomologist appended to it, to draw attention to the great value, as object lessons, of the diagrams of injurious insects prepared by Miss Ormerod.

The report of the Committee was then unanimously adopted.

#### Veterinary.

Mr. DENT (in the absence of Sir John Thorold, Chairman) submitted the following report presented by Mr. Cope:—

**PLEURO-PNEUMONIA.**—During the four weeks ended April 25, there were thirteen fresh outbreaks of this disease in Great Britain reported to the Board of Agriculture, five of which were in England, in the counties of Chester, Lancaster, and York (W. R.), and eight in Scotland, seven of which were in Midlothian and one in Lanarkshire. In dealing with these outbreaks the Board of Agriculture slaughtered eighty-five diseased cattle, and 557 which had been exposed to the risk of infection. In addition to this the Board authorised the slaughter of fifteen other cattle which were suspected of being affected with pleuro-pneumonia, but which were found free from that disease on post-mortem examination. In Ireland fourteen fresh outbreaks of pleuro-pneumonia occurred in the four weeks; twenty diseased cattle were killed, and one died, while 399 healthy contact-cattle were slaughtered.

**ANTHRAX.**—There were eighteen fresh outbreaks of anthrax reported in Great Britain in the four weeks, in the counties of Devon, Dorset, Leicester, Lincoln (Lindsey), Middlesex, Notts, Somerset, and Suffolk in England, and in Aberdeen, Forfar, Kirkcudbright, Linlithgow, and Perth in Scotland; thirty-one animals were attacked, twenty-five of which died, and four remained alive when the last published return was made up.

**SWINE-FEVER.**—In Great Britain 568 fresh outbreaks of this disease were reported; 3,066 pigs were attacked, 1,323 diseased swine were killed, 1,265 died, 211 recovered, and 578 remained alive on April 25.

**RABIES.**—There were four cases of this disease in the month, in the counties of Essex, London, Surrey, and York (W. R.)

Correspondence as to an epizootic outbreak in Yorkshire amongst lambs, and as to scab in sheep had been laid upon the table. A discussion had arisen on the subject of abortion in cows, and it was agreed to recommend that a communication should be addressed from the Society to the Royal Veterinary College, asking whether in the opinion of the College the time had not now arrived for a further investigation into the causation of this disease, and, if so, whether the College were prepared to recommend what action should be taken. Mr. Stanyforth had been added to the Committee.

Mr. DENT said there was a very strong feeling in the agricultural world that this matter of abortion in cattle was almost as serious as anything which affected the herds of this country. (Hear, hear.) In spite of all the enquiries that had been made, no satisfactory information had been obtained as to the nature of it, or as to the means of prevention. The Veterinary Committee were unanimously of opinion that the Society should consult the Royal Veterinary College as to whether any means could be adopted against it.

#### Stock Prizes.

Mr. SANDAY (Chairman) presented the recommendations of this Committee as to certain proposed entries for the Doncaster Meeting, which they advised should be declined. The Committee had given preliminary consideration to the Stock Prize-sheet for the Warwick Meeting, and after considerable discussion of the several suggestions, it had been decided to put the draft Prize-sheet into type for further consideration at the next meeting.

#### Judges' Selection.

Mr. SANDAY (Chairman) reported that all the gentlemen nominated as Judges in the several departments of the Doncaster Meeting had signified their willingness to act, and that the Umpires had been selected by the Committee.

**Implement.**

Mr. FRANKISH (Chairman) reported that the total amount of space allotted in the Implement Department at the Doncaster Meeting was as follows: Ordinary shedding, 8,343 ft.; special shedding, 2,106 ft.; machinery-in-motion, 2,024 ft. Total, 12,473 feet run. The Committee recommended the acceptance of the offer of Messrs. Hornsby and Sons to provide, free of cost to the Society, an engine and threshing-machine, with trusser attached, for the purposes of the Threshing-Machine Trials.

**General Doncaster.**

Mr. DENT said before he proceeded to the business of the General Doncaster Committee he was allowed by the gracious permission of His Royal Highness the Prince of Wales to state that the Prince and Her Royal Highness the Princess hoped to visit the Society's Show at Doncaster. (Loud cheers.) When his Royal Highness's arrangements were completed, it would be made known to the members on which day of the show they would be able to be present.

The PRESIDENT said he was sure the Council would allow him on behalf of the Society to express the great gratification and pleasure of the members of the Society at the announcement which they had just heard. His Royal Highness the Prince of Wales took on every occasion the deepest interest in all their national industries, but perhaps in no industry did he take more interest than in that of agriculture. He felt that he could not let that opportunity pass without expressing their great gratification at learning His Royal Highness's gracious intention to be present at the Royal Show at Doncaster. (Cheers.)

Mr. DENT then reported that the General Doncaster Committee had considered and approved the provisional programme for the Doncaster Meeting, and had altered the time of the cattle parade on the Wednesday of the show from 11 a.m. to 12 noon; the final details to be settled by the Honorary Director and the Secretary. Applications had been received from

the Shire-horse Society, British Berkshire Society, Shorthorn Society, Hunters' Improvement Society, and Hackney Horse Society, to hold meetings in the Doncaster showyard, and had been granted on the usual conditions. The Secretary had been instructed to communicate with the Vicar of Doncaster as to the arrangements for the preaching of the sermon at the Sunday service, in view of the lamented decease of the Archbishop of York. A letter had been received from the St. John Ambulance Association, undertaking the ambulance arrangements in the showyard. The Committee considered it desirable that a lecture on horse-shoeing should be given in the shoeing-shed on the Wednesday afternoon of the show.

**Show-yard Works.**

Sir JACOB WILSON (Chairman) reported that the Implement Yard at Doncaster was now completed and the stands allotted; that the entrances and offices were in a very forward state; a large number of horse-boxes, cattle-sheds, refreshment-rooms, &c., were built; and that the works generally were well in hand. The Local Committee had laid the water-mains, and were now finishing the services about the Yard. The levelling was almost complete, and only a few holes about the Yard required filling in. The Committee had approved certain additions to the Royal Pavilion at Doncaster, according to the plan submitted by the Surveyor. They recommended that an office for receiving milk in the Show-yard be erected at Doncaster in a similar manner to that at Plymouth.

**Selection.**

Earl CATHCART said the time had come when the subject of the choice of a President for the next year must be considered. The Committee of Selection were unanimous on the subject, which had been discussed by them at two meetings. They thought it would be agreeable that the noble Lord whose name they submitted should be nominated in his own county of York, and that it would be desirable and advantageous for the

Society to have the services of the Earl of Feversham as President for the ensuing year. He, therefore, moved "That the Earl of Feversham be recommended to the General Meeting as President for the ensuing year."

This was seconded by Lord EGERTON OF TATTON, and carried unanimously.

On the motion of Earl CATHCART, seconded by Viscount BRIDPORT, the Earl of Ravensworth was elected a Trustee in the room of the late Duke of Bedford.

On the motion of Earl CATHCART, seconded by Sir NIGEL KINGSCOTE, Lieutenant-Colonel Curtis-Hayward, of Quedgeley, Gloucester, was elected a member of Council, in the room of the Earl of Jersey, resigned.

#### Education.

Lord MORETON (Chairman) reported that Dr. Fream's paper and the Committee's reports on Technical Education in Agriculture had been reprinted and circulated amongst the County Councils, as ordered at the last meeting, and the Secretary had submitted a number of letters received in response to the Society's circular. A communication had been received from the Charity Commission, submitting copies of the scheme for the future administration of the Foundation of Dauntsey's School and Almshouses at West Lavington, as approved by Her Majesty in Council. The Committee recommended that their Chairman, Lord Moreton, be appointed the Society's Representative Governor upon the Foundation, as provided by Clause 3 of the scheme, and in accordance with the Council's resolution of February 5, 1890. Memorials had been considered from authorities at the Oxford and Cambridge Universities, asking if the Society would support an application to the Board of Agriculture to grant a sum of 10*l.* or 15*l.* a head to a limited number of graduates, to enable them during the ensuing spring and summer to visit some of the best farms and agricultural institutions of the country, under the guidance and with the assistance of a qualified person, to be selected by the Royal Agricultural Society or by

the Board of Agriculture. It had been resolved to recommend that the Secretary be instructed to state in reply to these memorials that, in the opinion of the Council, it would be better, before taking such action as was proposed, to wait until the scheme for scientific teaching in agriculture at the Universities making the application should have been finally settled.

A formal resolution for the election of Lord Moreton as the Governor representing the Society on the Foundation of the Dauntsey Agricultural School was proposed by Mr. DENT, seconded by Lord EGERTON OF TATTON, and carried unanimously, and the remainder of the report was also adopted.

#### Dairy.

The Hon. CECIL T. PARKER (Chairman) presented the recommendations of this Committee as to various matters connected with the Dairy Department at the Doncaster Meeting. It was proposed to arrange for the giving of lectures on dairy matters by Dr. Voelcker and Mr. Rigby during the Show-week.

#### Retiring Members of Council.

A list (see p. lvi.) of the 25 members of Council who retire by rotation was laid before the Council in accordance with Bye-Law 23 (c).

#### Country Meeting of 1893.

On the motion of Sir JACOB WILSON, seconded by Mr. S. P. FOSTER, it was resolved that the Country Meeting of 1893 be held in District G., which consists of the counties of Chester and Lancaster, and of North Wales.

#### Miscellaneous.

A letter of thanks was read from the Organising Committee of the International Congress of Hygiene, thanking the Society for its grant of 50*l.* towards the expenses, and various other letters and documents were laid upon the table.

The report from the Council to the General Meeting to be held on Friday, the 22nd instant, having been prepared, the Council adjourned till Wednesday, June 3rd, at noon,

WEDNESDAY, JUNE 3, 1891.

THE EARL OF RAVENSWORTH (PRESIDENT) IN THE CHAIR.

Present:—

*Trustees.*—General Viscount Bridport, K.C.B., Earl Cathcart, Mr. John Dent Dent, Colonel Sir Nigel Kingscote, K.C.B., Sir A. K. Macdonald, Bart.

*Vice-Presidents.*—Earl of Feversham, Right Hon. Sir Massey Lopes, Bart., Lord Moreton, Sir John Thorold, Bart., Mr. C. Whitehead.

*Other Members of Council.*—Mr. G. M. Allender, Mr. Alfred Ashworth, Mr. Joseph Beach, Mr. J. Bowen-Jones, Lord Brougham and Vaux, Mr. J. A. Caird, Mr. Charles Clay, Lieutenant-Colonel J. F. Curtis-Hayward, Mr. Alfred Darby, Mr. C. De L. Faunce De Laune, Mr. S. P. Foster, Mr. William Frankish, Mr. James Hornsby, Mr. Charles Howard, Mr. C. S. Mainwaring, Mr. Joseph Martin, Mr. Albert Pell, Mr. Daniel Pidgeon, Mr. S. Rowlandson, Mr. G. H. Sanday, Mr. W. T. Scarth, Sir J. L. E. Spearman, Bart., Mr. J. P. Terry, Mr. John Tremayne, Mr. R. A. Warren, Mr. E. V. V. Wheeler, Sir Jacob Wilson.

Mr. A. C. Cope, of the Board of Agriculture.

*Officers.*—Mr. Ernest Clarke, Secretary and Editor; Professor J. B. Simonds, Consulting Veterinary Surgeon; Dr. J. Augustus Voelcker, Consulting Chemist.

The following members of the Doncaster Local Committee were also present: The Mayor of Doncaster (Mr. Alderman Stockil), Mr. J. Firth Clark, Mr. F. Bacon Frank, Mr. John White, Mr. G. T. Wood, Mr. G. B. C. Yarborough, and Mr. George Chafer (Secretary of the Local Committee).

#### Apologies for Non-Attendance.

Apologies for non-attendance were announced from H.R.H. Prince Christian, K.G., the Duke of Richmond and Gordon, K.G., the Earl of Coventry, Viscount Emlyn, Hon. Cecil T. Parker, Sir Matthew Ridley,

Bart., M.P., Mr. Walter Gilbey, Mr. Henry Smith, Mr. E. W. Stanyforth, and Mr. Garrett Taylor.

#### Death of the Earl of Powis.

The minutes of the last Council meeting, held on May 6, having been read and confirmed,

The PRESIDENT said it had already been his painful duty as President to announce to the Council the loss by death of one of the Trustees of the Society, the Duke of Bedford, and it now devolved upon him to report officially to them the death of another of their most distinguished colleagues, the Earl of Powis, who had been a member of their body for the long period of thirty-five years. Elected as a Member of Council in June, 1856, Lord Powis speedily took an active share in all the different departments of the Society's work, and in 1860, he was elected President for the year 1860-61. His Presidential year was marked by the most successful show, both in point of attendance and finance, that had ever been held up to that time; and members of Council who were present at their meeting held in March, 1890, would remember his vivid description of the scene at the turnstiles at the Leeds Show of 1861. At the end of that year his Lordship was elected a Trustee of the Society, and had held that position ever since. Lord Powis was an original member of the Education Committee, which had had recently so important a development; and up to the end of his useful life, he took the greatest interest in the cause of agricultural education. Acting upon what he felt confident would be their unanimous wish, that the Council should be officially represented at Lord Powis' funeral, he (Lord Ravensworth) had requested their colleague Mr. Mainwaring, who shared with Lord Powis the representation of Wales, to be so kind as to act for the Society in that capacity; and in the

immense assemblage which followed his Lordship's remains to the grave, Mr. Bowen-Jones, another of their members, and a life-long tenant on the Powis Estate, was also included. He was sure that every member of the Council would feel that by the death of Lord Powis they had lost one of their most distinguished and honoured colleagues, one who had served the Society long and well, and who had devoted himself unsparingly to its interests.

The PRESIDENT added that he regretted to announce the death, at the age of eighty-three, of one of the original members of the Society, Mr. R. Dawtrey Drewitt, of Arundel, who was elected a member on March 11, 1840, and as such was made a Foundation Life Governor on March 5 of last year.

#### Election of New Members.

The election of the following 70 Members was then proceeded with:—

BACKHOUSE, C. R. . . . Ainderby Hall, Yorkshire.  
 BAILLIE, G. S. . . . Doward House, Mounmouth.  
 BAYNES, T. . . . Bainbridge, Bedale.  
 BRIGHT, R. . . . 30, High Street, Leominster.  
 †BURTON, P. C. . . . Pontyclown, Glamorgan.  
 CARMICHAEL, T. D. G. . . . Castle Craig, N.B.  
 CARTER, T. . . . Burnham, Doncaster.  
 CARTWRIGHT, F. W. . . . Martin Common, Bawtry.  
 CHARLES, T. R. . . . 7, Gloucester Rd., Weymouth.  
 CHETWYND, A. . . . Longdon Hall, Rugeley.  
 CLAY, James . . . Beckingham Hall, Notts.  
 CRAWFORD, P. . . . Carruchan, Dumfries, N.B.  
 DEWEY, J. . . . The Farm, Waltham Cross.  
 DRINKWATER, G. . . . Kirby, Douglas, I. M.  
 †DROUCE, Edric . . . R. A. College, Cirencester.  
 ELWIS, J. O. . . . Avenue House, Doncaster.  
 ESTCOURT, Miss E. . . . Standen, Newport, I. W.  
 FIFE, H. L. . . . Sudborough, Thrapston.  
 FISHER, E. A. M. T. . . . Welby Warren, Grantham.  
 FITCH, C. F. . . . Whittles Hall, Essex.  
 FORTESCUE, J. B. . . . Boconnoe, Lostwithiel.  
 GARSTON, Capt. E. J. . . . Prizet, Kendal.  
 GILL, H. S. . . . Woodhayes Hall, Sale.  
 GILL, W. P. . . . Woodhayes Hall, Sale.  
 GOODWILL, R. . . . North Ings, York.  
 †GUNTER, J. . . . Glasbury, Radnorshire.  
 HARRISON, W. H. . . . Grassendale Park, Liverpool.  
 HERD, T. . . . Scothorne Manor, Lincoln.  
 HICKMAN, W. H. . . . Broome, Stourbridge.  
 †HILL, H. F. . . . Agricultural College, Aspatria.  
 HOLDEN, A. J. . . . Doncaster.  
 HULKES, C. J. G. . . . Pettings House, Ash, Kent.  
 JACKSON, N. B. . . . Acomb, York.  
 JENNINGS, R. . . . Rossington Grange, Doncaster.  
 KITCHIN, C. S. . . . Spring Lodge, Knottingley.  
 KITCHING, Robert . . . Hungate, Pickering.  
 KNIGHT, Frank . . . Yarnhams, Alton, Hauts.  
 LAITHWOOD, James . . . Congleton.

‡ Life Member by Examination.

‡ LISTER, J. . . . Agricultural College, Aspatria.  
 LITTLEFAIR, J. H. . . . Bonis, Shap.  
 MAYNARD, W., Jun. . . . Alma House, Romsey.  
 MEAKIN, L. J. . . . Needwood Side, Tatenhill.  
 MOORHOUSE, J. W. . . . Flanshaw Mills, Wakefield.  
 MUSSON, R. D. . . . Mayfield, Clitheroe.  
 MYOTER, C. G. . . . The Oxhay, Biddulph, Staffs.  
 NALDER, F. . . . East Keal Hall, Spilshy.  
 NEWBORN, R. . . . Haxey, Bawtry, Lincs.  
 ORMOND, W. G. . . . Shenley, Bletchley.  
 OWEN, W. S. . . . Cefngwifed, Newtown, Mont.  
 PARSONAGE, T. . . . White Gate, Malpas.  
 †PATEL, R. B. . . . R. A. College, Cirencester.  
 PINNOCK, William . . . Wantage, Berks.  
 PLATT, George . . . Eaton, Tarporley.  
 PRITCHARD, W. E. G. . . . Ceniarth, Machynlleth.  
 READER, L. . . . Brenchley, Kent.  
 ROBINSON, A. M. . . . Shirley Lodge, Milton, Camb.  
 SLACK, A. S. . . . Skirwith Hall, Culgaith, Carlisle.  
 SMITH, E. . . . Wavertree, Liverpool.  
 SMITH, J. . . . Hampton-in-Arden, Birmingham.  
 SMITHES, J. T. . . . Eveley, Liphook.  
 SPILMAN, G. . . . Broughton Vale, Brigg.  
 †STAPLETON, E. A. . . . R. A. College, Cirencester.  
 THOMPSON, O. B. . . . High Jervaulx, Bedale.  
 TREVITHICK, H. H. . . . Tolroy, Hayle, Cornwall.  
 TURNER, Thomas . . . Regent Square, Doncaster.  
 WAUD, G. C. . . . Bradford, Yorks.  
 WHITLOW, J. . . . Garland Hall, Crowley, Northwich.  
 WHITLOW, J. . . . Appleton, Warrington.  
 WILSON, D. B. . . . Seacroft Hall, Leeds.  
 †YOUNG, H. A. L. . . . West Horsley, Leatherhead.

#### New Member of Council.

Earl CATHCART, as Chairman of the Committee of Selection, introduced Col. Curtis-Hayward, the newly elected Member of Council, and the PRESIDENT said they were very glad to welcome Col. Hayward as one of their number.

Their reports of the various Standing Committees were then presented and adopted as below:—

#### Finance.

Sir NIGEL KINGSCOTE (Chairman) reported that the accounts for the month of May, 1891, as certified by the Society's accountants, showed total receipts amounting to 1,983*l.* 19*s.* 11*d.*, and expenditure amounting to 2,387*l.* 13*s.* 8*d.* The balance at the bankers' on May 30 was 7,288*l.* 1*s.* 1*d.* Accounts amounting in all to 6,157*l.* 7*s.* 11*d.* had been passed, and were recommended for payment. The total receipts up to May 30, in respect of the Doncaster Meeting, were 5,916*l.* 9*s.* 4*d.*, as against 4,277*l.* 13*s.* 3*d.* at Plymouth.

A statistical statement as to the number of members elected during

‡ Life Member by Examination.

the Society's jubilee year, who still remain on the Society's books, had been submitted, and ordered to be entered upon the minutes. The statement showed that of 2,745 members elected during that period, 81 per cent. had paid all their subscriptions to date, 10 per cent. still owed subscriptions, 2 per cent. were dead, and only 7 per cent. had resigned, or had been struck off for other reasons. The Committee recommended that the names of eighteen members who were deceased, and nineteen who had resigned, be struck off the Society's books.

#### Season Tickets for Doncaster Show.

Sir JACOB WILSON raised the question of granting to members of the Society the privilege of purchasing season tickets for their friends, who might be attending the Doncaster Meeting with them; and after some conversation, in which Mr. DENT, the Earl of FEVERSHAM, Sir NIGEL KINGSCOTE, the PRESIDENT, and Mr. PELL took part, it was agreed, upon the motion of Sir JACOB WILSON, seconded by Mr. DENT, that season tickets, entitling to admission and readmission at any time the show is open to the public, be issued by the Secretary to members for their friends, at the price of half a guinea each.

#### House.

Sir NIGEL KINGSCOTE (Chairman) presented the recommendations of the Committee as to certain necessary repairs in the Society's house, and the repainting of the general offices.

#### Journal.

Earl CATHCART (Chairman) reported that the arrangements proposed by the Editor for the next number of the Journal had been considered and approved. Various suggestions for articles and notes in the Journal had been discussed, and directions given thereon. The Board of Agriculture, having consented to place at the disposal of the Society 10,000 copies of their recent pamphlet on experiments in checking Potato Disease, the Committee recommended that a copy be sent to each member with the next number of the Journal, and that the action of the Board in

the matter be duly acknowledged. Applications from the Melbourne Public Library and the Newcastle-on-Tyne Public Library to be placed on the free list of the Journal had been granted.

#### Chemical.

Mr. WARREN presented the report of this Committee, which dealt with various matters arising out of the Chemical Department, together with the Quarterly Report of the Committee and the report of the Woburn Sub-Committee. The Woburn Sub-Committee had reported their visit to the Experimental Farm and Fields on May 21, when they had found everything in capital order.

Mr. WARREN said that Sir John Lawes attached considerable importance to the fact of the Stackyard Field having been formerly ancient pasture, although it was more than sixty years ago that it was broken up. This seemed to call for the special attention of the agricultural chemists as to whether it would not be a very great gain if they could find out how to nitrify the soil artificially, so that it would give off its nitrogen gradually as when nitrified by nature, instead of applying nitrate of soda, which was so fugitive that one or two crops exhausted the effect of it.

Mr. PELL thought it was due to Mr. Elliott, the Manager of the Woburn Farm, and to those interested in the management of the experiments there, that he should express, on the part of himself and his colleagues who visited the farm on the 21st ult., the greatest satisfaction at the careful way in which the work was being carried out. In his judgment there was nothing left to be desired, so far as attention could secure efficiency in the conduct of the experiments.

On the motion of Mr. WARREN, seconded by Mr. DENT, it was unanimously resolved that the Quarterly Report of the Chemical Committee be received and adopted, and be published in the usual manner. (See page 398.)

#### Seeds and Plant Diseases.

Mr. WHITEHEAD (Chairman) reported that a letter had been received

from the Board of Agriculture, conveying the thanks of the Board for the Society's prompt response to the invitation to undertake experiments with potatoes, and intimating that the Board would be prepared to provide a sum not exceeding 100*l.* during the current financial year to defray the expenses of the investigation. Mr. Carruthers had submitted the proof of a coloured diagram, with explanatory notes, illustrating the potato disease, prepared by him for the Irish Land Commission. The Committee recommended that 1,000 copies of this diagram be printed for the Society as a first edition, and sold at the rate of 6*d.* each. A report had been submitted by Miss Ormerod on the wheat bulb maggot, which the Committee recommended should be published. (See page 394.)

The Sub-Committee on Potato Experiments, appointed at the last meeting of Council, had held two meetings on May 12 and June 2, and the following report from them had been adopted by the Seeds and Plants Committee:—

#### Report of Sub-Committee on Potato Experiments.

1. The Sub-Committee propose that experiments on potatoes with sulphate of copper be carried on during the ensuing season in the following six districts: Devon, South Wales, Lancashire, Lincolnshire, Kent, and Bedfordshire.

2. That in each district a plot of 3 acres be set apart on a selected farm, 1 acre to be treated with sulphate of copper, applied early as a preventive; 1 acre to be treated later, should the disease make its appearance thereon; and 1 acre to be left without treatment.

3. The application of the dressing to be made in every case under the direction of a skilled person, to be appointed by the Society. The Committee recommend that Mr. Edmond Riley, of The Weir, Hessle, Hull, be charged with the superintendence of the application of the dressing.

4. During the period of growth, the experiments to be inspected by

the Consulting Botanist of the Society.

5. The produce when dug up to be separated and weighed, under the superintendence of a person appointed by the Society.

Mr. WHITEHEAD added that the Committee were greatly indebted to Monsieur Paul Aubert, of St. Hilaire, St. Florent, France, who kindly attended on the 2nd inst. and gave useful information upon points necessary to be observed in the preparation and application of the "Bouillie Bordelaise" mixture.

Mr. F. BACON FRANK, as a member of the Doncaster Local Committee, asked whether it was intended to carry out experiments with potatoes in the county of York, in which there were some of the largest potato growers in the Kingdom.

Mr. WHITEHEAD replied that the Sub-Committee had very carefully considered the question of the localities for experiment, and they thought that six districts would be quite enough. One of those districts was Lancashire, not very far from Yorkshire, and he thought that that would be sufficient as representing a large potato district. Various offers of land for the purpose of the experiments had been received by the Committee, and he ought perhaps to state that it was proposed to take the Isle of Axholme as the part of Lincolnshire to be experimented upon.

Mr. HOWARD asked whether the potato itself had been dressed, or whether it was attacked by the disease afterwards. It was a common practice to dress wheat and barley before sowing, as the fungus was thought to be on the seed itself. It was still not too late to plant potatoes, and he thought it desirable that experiments should be made on this point.

Mr. WHITEHEAD replied that experiments had been made in the United States, by pickling the potato as they pickled wheat, with sulphate of copper or blue-stone. The results were not satisfactory, and the disease was not checked. The fungus, or the fungus in that stage, was in the potato, and could hardly be affected by an external application of sul-



phate of copper, which would not reach the fungus within. The fungus ascended with the growing stalk of the potato, and would not probably come into contact with any sulphate of copper dressing that had been applied. This, of course, would not affect the oospores or "rest" spores in or on the ground. The idea had not been entertained by the Sub-Committee because it seemed to be contrary to scientific opinion. The Sub-Committee would, however, carefully consider Mr. Howard's remarks, and if it were possible to make any addition to their experiments they would do so, though he feared that it was now too late.

The PRESIDENT asked whether the dressing of the potato in the same way as wheat or barley, with such a strong mixture, would affect the fructifying qualities of the root itself.

Mr. WHITEHEAD replied that there would not be the least danger, even if the potato were a cut-seed and not a whole-seed potato. Such a treatment would be likely to be more effectual in the case of cut-seed than whole-seed; but he questioned whether it would be efficacious at all, because a potato-tuber was an altogether different thing to a seed of corn, besides which, the fungi that attacked the two kinds of crop were quite distinct.

#### Veterinary.

SIR JOHN THOROLD (Chairman) stated that Mr. Cope (for Professor Brown) had presented the following report: and that a Parliamentary Return, showing the number of outbreaks of swine fever during the past three years had been laid upon the table:—

*Pleuro-pneumonia.*—During the four weeks ended May 23, twenty-three outbreaks of this disease were dealt with by the Board of Agriculture in seven counties in England and two in Scotland, viz., Kent, Lancaster, Middlesex, Northampton, Northumberland, York (N.R.), York, (W.R.), Aberdeen, and Midlothian. In these counties ninety cattle affected with the disease were slaughtered, sixty-six in England and twenty-four in Scotland; in addition to these 538 healthy

cattle, which had been exposed to the risk of infection, were slaughtered, 356 of these were in England and 182 in Scotland.

There were during the four weeks fourteen cattle slaughtered which were suspected of being affected with pleuro-pneumonia, but which were found, on post-mortem examination, to be free from that disease.

For the corresponding period of last year, there were forty-one fresh outbreaks, in which 176 diseased and 804 healthy cattle were slaughtered by the local authorities.

The following Table shows the number of outbreaks of this disease, with the number of animals killed between September 1, 1890, when the Pleuro-pneumonia Act came into operation, and the 23rd of May last, as compared with the corresponding period for the years 1889-90:—

	1890-91	1889-90
Outbreaks . . . . .	217	263
Diseased cattle slaughtered . . . . .	834	1,192
Healthy cattle in contact slaughtered . . . . .	8,012 <sup>1</sup>	4,083

*Anthrax.*—During the four weeks fourteen outbreaks of anthrax were reported in Great Britain, in the counties of Berks, Bucks, Essex, Kent, Lancaster, Leicester, Lincoln (Kesteven), Lincoln (Lindsey), Northumberland, Suffolk, York (W. R.), Aberdeen, and Midlothian. In these outbreaks sixty-five animals were attacked, nine of which were killed, forty-one died, five recovered, and thirteen remained alive diseased when the last return was made up.

*Swine fever.*—This disease continues to increase in Great Britain. There were 688 fresh outbreaks reported in the four weeks, as compared with 568 in the preceding four weeks; 4,038 swine were attacked, 2,004, or less than half these diseased pigs were killed, 1,587 died, 226 recovered, and 744 remained alive diseased when the return was made up.

<sup>1</sup> In addition to the 8,012 healthy contact cattle slaughtered in 1890-91, 153 cattle suspected of being affected with the disease were also slaughtered, but were found to be free from it, although affected with other diseases.

**Rabies.**—There were eight cases of rabies in dogs reported, viz., one in Lancaster, one in London, one in Middlesex, one in Somerset, and four in York (W.R.).

Considerable discussion had taken place upon the recent large increase in the number of outbreaks of swine fever, and it had been agreed to submit the following resolution for adoption by the Council:—

Seeing that swine fever is largely on the increase, and that the measures at present in force are inadequate to check, much less suppress it, the Council would earnestly direct the attention of the Board of Agriculture to the urgent necessity of adopting more stringent measures to mitigate the severity of this disease.

The attention of the Committee had been drawn to a communication, addressed by the Highland and Agricultural Society of Scotland, to the Board of Agriculture, as to the exhibition in England and Scotland of cattle exhibited at the Royal Dublin Society's Show, held at Dublin last March, within, or in close proximity to, a district scheduled under the Pleuro-pneumonia Order. The Committee were of opinion that no animals which were now in, or which had been exhibited in, a scheduled district should be admitted to the Royal Agricultural Society's Show at Doncaster, and that if any such animals had been entered, their owners should be informed of this resolution, the entries cancelled, and the fees returned.

The Committee recommended the appointment of Mr. D. M. Storrar, of Abergavenny, as the Society's Provincial Veterinary Surgeon for Monmouthshire, in succession to Mr. Lewis, resigned.

A letter had been read from Sir Joseph Lister, Chairman of the Executive Committee of the British Institute of Preventive Medicine, seeking the Society's support in an application to the Board of Trade for a licence to the Institute enabling them, as a "charitable institution not working for profit," to omit the word "limited" from their proposed title, and asking that the President

and Council of the Society might be officially represented at a deputation in support of the application which was appointed to wait upon Sir Michael Hicks-Beach on the 5th instant. The Committee recommended that the Secretary be instructed to express the approval of the Council in the object of the application made by the Institute, but that they were not able to take part in the proposed deputation.

#### Swine Fever.

Mr. DENT, with reference to the proposed resolution as to swine fever, said the question was whether the Council were prepared to make any definite recommendations to the Board of Agriculture on the subject. There was a very general feeling in the Veterinary Committee on the previous day that if any more was going to be done, some far more stringent measures should be adopted than were in force at the present time. There was a strong feeling amongst those who had anything to do with the subject, practically, that they should stop for some considerable period throughout the United Kingdom all markets for swine. There was no doubt that the disease was principally contracted by animals being taken to markets which could not well be cleaned, and which were always more or less centres of infection. In addition to that they must carry out a more stringent law of slaughter and compensation. In certain districts of the West Riding of Yorkshire every collier had a pig, and in the neighbourhoods of Sheffield, Barnsley, and Ripon the disease was always more or less existing in the pigstyes of the colliers—places very ill-adapted to the keeping of swine. But he questioned whether, even if they resorted to slaughter, they would ever thoroughly eradicate or stamp out the disease in localities of the kind. Looking to the little impression made upon the disease and the carelessness and recklessness of pig-owners and pig-dealers, and people connected with the trade, he should be inclined rather to strike the disease out of the Contagious Diseases (Animals) Act altogether, and let proprietors of pigs take their own

risk. There would always be more or less disease amongst pigs whilst they had the law unequally administered in different parts of the country. The visits of the veterinary surgeons and the inspection of the districts were a very serious inconvenience to the pig trade. Farmers at that moment would tell them that pigs were worth nothing, and that they were almost unsaleable. If they were really prepared to go to the Board of Agriculture saying that they must strike at the root of the evil and adopt these more stringent regulations in the way of the keeping of pigs, they would have a serious outcry all over the country, and he could not support such a resolution. He should feel much more inclined to strike swine fever altogether out of the list of contagious diseases.

Sir NIGEL KINGSCOTE could not at all agree with Mr. Dent. Everyone admitted that swine fever was becoming a serious scourge. If they gave compensation they got more swine fever than really existed. He did not think that the Council should express an opinion beyond saying that more stringent regulations should be adopted. But it was his own very strong view that it would be a very great step towards getting rid of the disease if, as Mr. Dent said in the first part of his remarks, all fairs and markets for pigs were stopped for a certain period. At the present moment his experience was that in markets where auctions were held once a fortnight or once a month on turf, cobbles, or stones, the dirt between them could not be cleaned away; those places could not be properly disinfected, and therefore the disease kept breaking out from time to time. He thought the Council would do well to call the attention of the Board of Agriculture to the matter by a general resolution, and he hoped that the remarks made there would reach the ears of the Minister of Agriculture, in order that he might see how to deal with the question. The responsibility lay with the Board of Agriculture.

Mr. BOWEN-JONES was disposed to think that it was premature to ask the Board to take action, because unless they imposed the most stringent measures they would not produce any

effect at all upon the disease. It was well known to the Council that the Board of Agriculture had in hand the question of the extermination of pleuro-pneumonia, and in his opinion that was quite as much as they could thoroughly accomplish at the present time. When the disease was extirpated—as he had no doubt it would be under the present system of management of the Board of Agriculture—he thought swine fever might be taken in hand, but till then he did not believe that the Board would be able to cope with the two diseases. Nothing short of the stoppage of fairs and markets throughout the kingdom, and slaughter with compensation from the Imperial Exchequer, would enable them to combat swine fever any more than pleuro-pneumonia. He, therefore, thought it rather premature to approach the Board except in general terms. He wished it to be distinctly understood that he only offered these observations on the general ground that he thought it was not the opportune time to ask the Board to deal with the question. If the terms of the resolution only called the attention of the Board to the matter in a general way, he did not object to its adoption.

Mr. HOWARD said Mr. Dent was quite correct in stating that the stoppage of fairs and markets would very much interfere with practical business throughout the country, and that it would be unpopular. It appeared to him desirable that the county authorities should take this matter up. They had tried it in Bedfordshire, and had not given any compensation for some time past. At that moment they were free from swine fever. There was a very prevalent impression amongst farmers and practical men that a great many cases reported were not swine fever at all. He did not mean to say that because they stopped compensation that that had had the effect of stopping swine fever, but it made owners more particular as to the way in which they kept their pigs, instead of allowing them to wallow in filth and dirt, which was a certain and prolific source of the disease.

Mr. MARTIN quite endorsed what had been said by Mr. Howard so far as the Isle of Ely was concerned.

They did not pay compensation, and they had not one case of the disease.

After some further discussion, the resolution of the Veterinary Committee in regard to swine fever was carried by sixteen votes to three.

#### **Entries of Stock from Districts Scheduled for Pleuro-pneumonia.**

Sir JOHN THOROLD then explained the recommendation of the Veterinary Committee in regard to the proposed exclusion from the Doncaster Show of animals exhibited at the Royal Dublin Society's Show last March. There was no doubt that, if this had been a scheduled district in England, the animals would not have been permitted to go to their show, because the Board of Agriculture had expressly declined to give a licence for the removal of any animals from such districts. But the Privy Council in Ireland were independent of the Board of Agriculture in England, and they had given those animals a licence to enter the scheduled district and to go back again to England. The Veterinary Committee thought that the Council should mark their feeling that it was extremely undesirable to admit to the show any animals from any district which had been scheduled for pleuro-pneumonia, and, therefore, they proposed that resolution.

Mr. HOWARD pointed out that the animals referred to were now being exhibited throughout the country. The question was whether the Royal Agricultural Society would do what other societies had not done. It appeared to him that the mischief, if any, had already been done, and that it was now too late for the Society to take action in the matter.

Mr. DENT said the matter came before the Veterinary Committee upon a letter received from the Highland Society, with a copy of their minute on this question. It certainly appeared to all the members of the Veterinary Committee that as that Council had been perpetually impressing upon the Board of Agriculture the necessity of dealing uniformly and stringently with pleuro-pneumonia, and that the rules and regulations made should be applicable to every district, they would only be acting consistently in passing

the resolution proposed. He understood that the Board of Agriculture had published an Order called The Scheduled Districts Order, and that when they declared the district scheduled as a pleuro-pneumonia district, no animal could move out of it unless for slaughter, without a special licence. What he understood was that certain exhibitors sent cattle into a scheduled district in Ireland, and that the authorities in Ireland gave those people certificates to enable them to remove their animals back again to England. They had not sufficient information to know on what they based their certificate, but apparently the authorities considered it safe for those animals to go back again. The feeling of the Committee was that the Council, having been so urgent in pressing the Board of Agriculture to deal uniformly and stringently in the matter, ought not to encourage the exhibition by the Royal Agricultural Society of any animals that had been in a scheduled district in England or in Ireland. He agreed with Mr. Howard that in all probability there was not much danger from those animals, but their exhibition would be at least a legal infraction of the rules that had been laid down, and the question was whether they should in any way encourage what might be a relaxation of them.

Mr. TERRY remarked that, supposing those animals had been in a scheduled district, they had been taken to other shows, and they had been in contact with other animals that would be exhibited at the Royal and at other shows all over the country.

Mr. PELL said the two things were quite distinct. If other shows had already exhibited those animals, that was no reason why the society should do so and carry the disease further over the country than it might have been carried already. The fact of their adopting the resolution would have its full effect next year. Breeders of cattle would take very great care not to exhibit their animals in a country which had different laws to their own and in which they would run the risk of infection. He was very strongly in favour of passing the

resolution, though it might not, as far as the disease was concerned, have effect this year. It would, however, be a most valuable caution next year.

Remarks having also been made by Mr. FOSTER and Lord MORETON,

The PRESIDENT, before putting the resolution, said he hoped and trusted that the Council would pass it for the sake of their own consistency. It was not fair that they should act with strictness in one matter and not in another.

The resolution was then put and carried, no one voting against it; and the report of the Veterinary Committee was then formally adopted.<sup>1</sup>

#### Stock Prizes.

Mr. SANDAY (Chairman) reported that in some instances considerable difficulty had been experienced in obtaining the necessary official Herd-book importation certificates for animals in the Jersey classes entered as eligible for entry in the Island Herd-book, and the Committee recommended that in cases where the regulations had not been complied with, the entries should be refused. The question of the veterinary inspection of stallions at the Doncaster Meeting had been considered, and the Committee recommended that it be an instruction to the Society's veter-

inary inspectors that the following diseases should disqualify a stallion, under Regulation 41 of the prize sheet:—Roaring-whistling, ringbone, unsound feet, navicular disease, spavin, side-bone, and cataract.

The Committee had further considered and amended the draft prize sheet for the Warwick Meeting, which they proposed to consider again after the recess.

#### Judges Selection.

Mr. SANDAY (Chairman) reported that, in view of the number of entries in the Shropshire sheep classes being too large for one set of judges, the Committee had decided that there should be two sets of judges.

#### Implement.

Mr. SANDAY (for Mr. Frankish) presented the report of this Committee, which dealt with various details as to the trials of threshing and milking machines at Doncaster, and of ploughs at Warwick next year.

#### General Doncaster.

Mr. DENT reported that the draft programme of the Doncaster Meeting had been submitted and approved; and announced that the visit of Their Royal Highnesses the Prince and Princess of Wales would take place on the Wednesday of the Meeting, when they would witness both the cattle and the parades. The Committee recommended that a lecture on Farriery, by Professor Pritchard, be given in the shoeing forge on Thursday, at 2 p.m. Applications from the National Pig Breeders' Association, and from Mr. George Barham, on behalf of implement exhibitors, for permission to hold meetings in the large tent in the showyard, had been granted on the usual conditions. A letter had been received from the Vicar of Doncaster stating that he had been unable to arrange with the Archbishop Designate of York, or with the Bishops of Beverley and Hull, to preach on the Sunday before the Show, and it had been unanimously agreed to ask the Vicar to preach himself.

#### Showyard Works.

Sir JACOB WILSON (Chairman) reported that the whole of the Imple-

<sup>1</sup> The following circular was addressed by the Secretary on June 11 to all intending exhibitors of cattle at Doncaster:—

Royal Agricultural Society of England,  
12 Hanover Square, London, W.,  
June 11, 1891.

Sir,—As numerous inquiries have been addressed to me with reference to a resolution passed by the Council at their last Meeting, having for its object the exclusion from the Doncaster Showyard of Cattle concerning which there is any risk of Pleuro-pneumonia, I am instructed to explain to you that it is the intention of the Society not to allow any Cattle to be exhibited at Doncaster which are at present in the Districts scheduled for Pleuro-pneumonia by the Board of Agriculture or the Irish Privy Council, or have been exhibited at Shows held within those Districts.

Exhibitors who have entered cattle for Doncaster which come within the terms of the above resolution, and who have not already received a letter from me on the subject, are requested to communicate with me at once, either by letter or telegram, in order that such entries may be omitted from the official Catalogue, and that the entry fees paid in respect thereof may be returned.

I am, Sir, your obedient servant,  
ERNEST CLARKE, Secretary.

ment Yard was completed, that a number of exhibits were in position, and that others were daily arriving. The horse-boxes and stock-sheds and other departments were in a very forward state.

#### Selection.

On the motion of EARL CATHCART, seconded by Mr. MAINWARING, Major W. T. E. Fosbery, of Warwick, was unanimously appointed the Steward of Forage for the Warwick Meeting of 1892.

#### Education.

Lord MORETON (Chairman) presented a detailed report (see page 407) by the Education Committee on the results of the recent senior examination, from which it appeared that twenty-one candidates entered, and thirteen actually competed, at the examinations which took place from the 12th to the 16th of May last, and that of these thirteen competitors nine had satisfied the examiners.

The Committee had given careful attention to the question of the issue by the Society of a further series of twenty-four diagrams of injurious insects, prepared by Miss Georgiana Ormerod. Miss E. A. Ormerod had had a personal interview with the Committee, and, on behalf of her sister, offered to present the copyright of the diagrams to the Society, upon the understanding that the out-of-pocket expenses incurred in the production of the diagrams be refunded by the Society. The Committee advised the Council to arrange with Miss Ormerod for the transference to the Society of the diagrams in question upon the terms proposed, and recommended that the thanks of the Society be given to Miss Ormerod and her sister for their generosity in the matter.

Lord MORETON, in presenting this report, said he desired to draw the attention of the Council to the fact that two of the prize-winners at the Senior Examination were young men under age. Mr. Edric Druce, who had won the second prize, had a hereditary connection with the Society. His great-grandfather and grandfather had both been original members, and had served on the Council; and his father was the

Honorary Secretary of the original Education Committee of the Society appointed a quarter of a century ago, and was well known to them all as the Secretary of the Farmers' Club. Mr. Edric Druce now joined the Society at the age of nineteen, under the most honourable circumstances, and he was believed to be the first instance in their experience of a fourth generation of uninterrupted association with the Society. Mr. Lister, aged 15, the fourth prize-winner, was the youngest candidate who had ever won a prize in their Senior Examination. He was the son of a miner, and, as a scholar of Aspatria, gained one of the Society's Junior Scholarships last November, coming out at the top of the list. He had now followed up this success by gaining a position in the Senior Examination, which must be regarded as highly creditable to himself and to the institution by which he was prepared.

#### Suggestion made at General Meeting.

The Council then considered the suggestion made by Mr. Frederick King at the General Meeting on May 22, viz., *That more attention should be paid by the Society to the education of the agricultural labourer.* It was decided that the answer of the Council should be that the Education Committee had already in hand the preparation of an agricultural text book for use in elementary schools in rural districts, and that they did not consider it advisable for the Society to take steps in the extensive direction suggested by Mr. King.

#### Miscellaneous.

A letter from the Imperial Institute, asking the Council to nominate a representative upon the permanent governing body, was considered, and it was, on the motion of Earl CATHCART, seconded by Lord BRIDPORT, resolved to nominate the President of the Society for the time being to act *ex officio* in this capacity.

Various other matters having been dealt with, the Council adjourned till Tuesday, June 23, at 2.30 p.m., in the Showyard at Doncaster; and it was at the same time arranged to have a daily meeting of the Council on the other days of the show at 1 p.m.

# Proceedings at 52nd Anniversary Meeting of Governors and Members.

FRIDAY, MAY 22, 1891.

THE EARL OF RAVENSWORTH (PRESIDENT) IN THE CHAIR.

Present:—

*Members of Council.*—H.R.H. Prince Christian, K.G., Earl Cathcart, the Earl of Feversham, Messrs. G. Mander Allender, James A. Caird, Percy. E. Crutchley, C. De L. F. De Laune, Henry Smith, John Tremayne, and C. W. Wilson.

*Governor.*—Mr. Thomas G. Benn.

*Honorary Member.*—Professor G. T. Brown, C.B.

*Members.*—Mr. J. A. L. Beasley, Captain John C. Best, Messrs. Horace F. Cox, Thomas Dunn, Captain E. Pennell Elmhirst, Messrs. Edwin Foden, Frederick King, Colin MacIver, W. Newzam Nicholson, Frank Proctor, R. Henry Rew, A. Seth-Smith, G. F. Sheppard, W. Tinning, Sir W. Vincent, Bart., Messrs. E. W. Voelcker, Jonas M. Webb, &c.

*Officers.*—Mr. Ernest Clarke, Secretary and Editor; Dr. J. Augustus Voelcker, Consulting Chemist.

The SECRETARY having read the Bye-Law governing the transaction of business at the anniversary meetings, it was moved by Captain ELMHIRST, seconded by Captain BEST, and unanimously resolved that the Earl of Feversham be elected President of the Society for the year ensuing the Doncaster Meeting.

The Earl of FEVERSHAM, in expressing his sincere thanks for the high honour the Society had conferred upon him, in electing him President for the year ensuing the Doncaster Meeting, said he need not remind them that the Royal Agricultural Society had carried on for more than fifty years a great and beneficent work in this country; and he might say that it had been the pioneer

if not the originator of all those great improvements which had taken place during that period.

At their Annual Exhibitions, inventions calculated to assist the farmer had been exposed to public criticism and brought to the test of practical experience. So well had the Society acted up to its motto of "Practice with Science" that the result, he did not doubt, had been "Progress with Safety." It was not too much to say that, under the auspices of that great Society, British Agriculture had been greatly improved, and that it had conferred upon the important industry in which they were engaged, and therefore upon the country at large, immense benefits. To have had a share, however small, in the great work of that Society was, he thought, a source of satisfaction to every member of it, and to every one who was engaged in its work. (Hear, hear.) And to be called upon to preside over its deliberations was an honour which, he need not say, he should highly value. In again thanking them, he would only express the hope that he might be able, in the discharge of the duties of the Presidential Chair, to follow in the footsteps and to imitate the example of his able and distinguished predecessors, in a manner which should meet with their approval and merit their confidence and esteem. (Cheers.)

The Trustees and Vice-Presidents were then re-elected by show of hands, the Chairman making sympathetic reference to the losses sustained by the deaths of the Duke of Bedford and the Earl of Powis, two of the Society's Trustees.

The election of twenty-five Members of Council was next proceeded with, and the President appointed

Mr. Horace Cox, Mr. Edwin Foden, and Mr. Jonas M. Webb, to act as scrutineers of the voting-papers. These having been duly collected, and the report of the scrutineers thereon received, it was announced that the twenty-five Members of Council who retired by rotation had been duly re-elected.

The SECRETARY having read the Report of the Council to the Meeting (see page x), its adoption was moved by Mr. THOMAS G. BENN, seconded by Mr. G. F. SHEPPARD, and carried unanimously.

On the motion of Mr. JOHN TREMAYNE, seconded by Mr. J. HERBERT TAYLOR, a vote of thanks was passed to the auditors (Messrs. A. H. Johnson, Francis Sherborn and C. Gay Roberts) for their services during the past half-year.

In response to the usual inquiry from the Chair as to whether any Governor or Member had any remark to make or suggestion to offer that might be referred to the Council for consideration,

Mr. FREDERICK KING drew attention to the question of the education of agricultural labourers. He advocated the establishment—by means of the funds of the Society, the funds of individual members of the Society, and the funds of the County Councils—of Model Farms in the vicinity of the Metropolis and such places as Birmingham, York, or Manchester, where intelligent boys from country parishes might undergo a system of training by the most eminent lecturers and teachers; so that after finishing their course they might return to their native villages to impart “at the blacksmith’s corner” some of the information they had gained. He said that great efforts had been made by Members of the Society for the benefit of those who could help themselves, and he urged that something should be done to help those who were incapable of so doing.

No other Member desiring to offer any remarks, Mr. NEWZAM NICHOLSON moved a vote of thanks to Lord Ravensworth for his able conduct in the Chair, remarking, in regard to what had been said by the previous speaker, that he had great faith in the County Councils; he thought that they would no doubt take energetic

and useful steps toward the advancement of the education of agricultural labourers.

Sir WILLIAM VINCENT seconded the resolution and remarked that the Surrey County Council, of which he was a member, were giving attention to the question of Technical Education; and he was very much in hope that the better education of the agricultural labourer would be one of the prominent branches of the subject that they would take into consideration.

The vote of thanks was then put by the SECRETARY and carried unanimously.

The PRESIDENT in replying congratulated the Society upon its choice of a President for the ensuing year. He thought they had selected a nobleman—a very old friend of his own—who would maintain the honour and dignity of that great Society as his predecessors had always endeavoured to do. He was quite sure that Lord Feversham, himself a practical farmer, and a most successful competitor at the Society’s Shows on many occasions, took a great interest in the Society, and in what he hoped and believed was a growing industry in this country. The question raised by Mr. King would receive the consideration of the Council, but he did not think that it would be within the scope of the Society to undertake any measures on a large scale for the education of the agricultural labourer, seeing that enormous sums were voted by Parliament towards elementary education in this country. After adverting to the establishment of agricultural sides in rural schools, his Lordship drew attention to the recently-issued pamphlet of the Board of Agriculture on sulphate of copper as a means of checking the potato disease, and to the increased intelligence now required from the agricultural labourer in the application of remedies such as these, as well as in the other operations of agriculture. It appeared to him that the Board of Agriculture was working admirably and most industriously for the improvement of the great industry which it was created to promote. In thanking them very cordially for the vote of thanks which they had passed, he had now only to declare the Meeting at an end.



# ROYAL AGRICULTURAL SOCIETY OF ENGLAND.

## Proceedings of the Council.

TUESDAY, JUNE 23, 1891,

(IN THE SHOWYARD AT DONCASTER).

**GENERAL VISCOUNT BRIDPORT, K.C.B. (TRUSTEE), IN THE CHAIR.**

### Present:—

*Trustees.*—General Viscount Bridport, K.C.B., Earl Cathcart, Mr. John Dent Dent, Col. Sir Nigel Kingscote, K.C.B.

*Vice-Presidents.*—Mr. H. Chandos-Pole-Gell, the Earl of Feversham, Sir John H. Thorold, Bart.

*Other Members of Council.*—Mr. G. Mander Allender, Mr. Joseph Beach, Mr. J. Bowen-Jones, Lord Brougham and Vaux, Mr. James A. Caird, the Earl of Coventry, Mr. Percy E. Crutchley, Lieut.-Col. J. F. Curtis-Hayward, Mr. C. De L. Faunce De Laune, Viscount Emlyn, Mr. W. Frankish, Mr. Hugh Gorringe, Mr. R. Neville Grenville, Mr. Charles Howard, Mr. C. S. Mainwaring, Mr. Joseph Martin, Mr. T. Horrocks Miller, Mr. Albert Pell, Mr. Daniel Pidgeon, Mr. J. E. Ransome, Mr. S. Rowlandson, Mr. G. H. Sanday, Mr. W. T. Scarth, Mr. Alfred J. Smith, Sir J. L. E. Spearman, Bart., Mr. E. Wilfrid Stanyforth, Mr. Martin J. Sutton, Mr. Garrett Taylor, Mr. Joseph P. Terry, Mr. John Tremayne, Mr. C. W. Wilson, Sir Jacob Wilson.

Professor Brown, C.B.

*Officers.*—Mr. Ernest Clarke, Secretary and Editor; Dr. J. Augustus Voelcker, Consulting Chemist.

The minutes of the last Council held on June 3, and of the Special Council held in the Showyard on June 22, were read and confirmed. The proceedings at the Special Council

included resolutions in reference to protests on account of alleged false pedigrees of horses; the granting of an application from the Agricultural Engineers' Association for permission to hold a meeting of their members in the large tent in the showyard; and decisions as to various other matters of detail in connection with the Show.

### Election of New Governors and Members.

The election of the following four Governors and forty Members was then proceeded with:—

#### *Governors.*

CHANDOS-POLE-GELL, H...Hopton Hall, near Wirksworth.  
MUNCASTER, Lord...Muncaster Castle, Raven-glass, Cumberland.  
OSWALD, Lord St...Appleby Hall, Doncaster.  
POWIS, Earl of...Powis Castle, Welshpool.

#### *Members.*

AFFLECK, Sir Robert, Bart...Dalham Hall, Newmarket.  
BELLASIS, Capt. R. Oliver...94 Piccadilly, W.  
BINDER, H...Kimberworth Park, Rotherham.  
BLACKETT, E. C...63 West Smithfield, E.C.  
BLAYDES, T. J...Epworth, Doncaster.  
BRETT, J...Banks House, Bingham, Notts.  
CLEASBY, W...Islebeck Grange, Thirsk.  
DARLINGTON, B...Barrow Lodge, Chester.  
DE BOISSIEU, F...Château de la Forêt, par Moulins, Allier; France.  
DE MORNAY, H...30 Chesterton Road North, W.  
DRURY, John...Leam, Eastoft, Goole.  
DUNN, T. D...Grovehill, Beverley.  
FINCH, Mark...Rowsham, Aylesbury.  
FRANKLIN, W...105 Burngreave Road, Sheffield.  
GLEW, R...Keady, near Doncaster.  
GROTH, Chev. L. A...3 Tokenhouse Build-ings, E.C.  
HEATON, K...Plas Heaton, Trefnant.  
HERRIES, Lord...Everingham Park, York.

HILL, J. M... The Holmes, Epworth, Doncaster.  
 HORNE, F... Hinnington, Shifnal.  
 HOROBIN, T. C... Crowle, Doncaster.  
 HUNT, A. R... Culpho, near Ipswich.  
 HUTTON, Col. G. H... Thorney Hall, Newark.  
 INMAN, Charles... Woodsetts, Worksop.  
 JAMES, L... Womersley, Pontefract.  
 MARTYN, R. E. P... Sberborne, Northleach.  
 MAW, R... The Curlews, Crowle, Doncaster.  
 MOSCROP, A... Todwick Grange, Kiveton Park,  
 Sheffield.  
 NICHOL, T... West Shields, Tow Law, co. Dur-  
 ham.  
 OTLEY, W. H... Ranskill, Bawtry.  
 PICKUP, P. R... Darrington, Pontefract.  
 SABIN, J. H... 16 Whitehall Place, S. W.  
 SANDERS, R. M. D... Sanders Park, Charleville,  
 co. Cork.  
 SMITH, W. W... Blacktoft House, Howden.  
 STANFORTH, W... Todwick, Sheffield.  
 STANLEY, Joseph... Radford, Leamington.  
 TAYLOR, Mrs... Misterton, Notts.  
 TAYLOR, Thomas... Epworth, Doncaster.  
 TREMAINE, Charles H... Castle Street, Laun-  
 ceston.  
 WARWICK DISTRICT SHIRE HORSE SOCIETY...  
 Leamington.

#### Finance.

Mr. SANDAY for Sir Nigel Kings-  
 cote (Chairman), reported that ac-  
 counts amounting in all to 3,205*l.*  
 10*s.* 9*d.* had been passed, and were  
 recommended for payment. The  
 Committee recommended that the  
 entry fees for cattle entered but not  
 sent by exhibitors who had shown  
 other cattle at the Dublin Spring  
 Show, or who could not send their  
 animals in consequence of their being  
 in scheduled districts, be returned to  
 their owners.

#### Journal.

Earl CATHCART (Chairman) re-  
 ported that the June number of the  
 Journal had been printed off, and  
 that copies would be issued to mem-  
 bers in the course of a few days. He  
 laid upon the table several copies of  
 the new number. The Committee  
 recommended the payment of various  
 accounts for printing and for literary  
 contributions in connection with the  
 Journal. An application by Dr.  
 Raineri, of the *Giornale di Agricoltura*,  
 Piacenza, for permission to re-  
 print in Italian Dr. Crookshank's  
 article on the tubercle bacillus, ap-  
 pearing in Part I. of the Journal this  
 year, had been granted on the usual  
 conditions.

In presenting this report Lord  
 CATHCART remarked that the Journal  
 was due to appear on June 30, and  
 he thought it was very creditable to  
 their Journal arrangements that they

had issued this number notwithstand-  
 ing the preoccupations of the Show,  
 and that the copies would be de-  
 spatched to members by the very day  
 of publication.

#### Veterinary.

Sir JOHN THOROLD (Chairman) re-  
 ported that the Secretary had laid  
 upon the table a statement of the  
 action taken by him to carry out the  
 resolution of the Council, passed on  
 the 3rd instant, with reference to the  
 exclusion of cattle from scheduled  
 districts. This action, and the issue  
 of the Secretary's circular of the  
 11th instant, had been approved. An  
 acknowledgment by the Board of  
 Agriculture of the resolution of the  
 Council relating to swine fever had  
 been laid upon the table.

The following report had been pre-  
 sented by Professor Brown:—

PLEURO-PNEUMONIA.—Since the  
 last meeting of the Veterinary  
 Committee the pleuro-pneumonia  
 returns for the three weeks ended  
 June 13 have been published in the  
*London Gazette*. During this period  
 fifty-seven cattle affected with the  
 disease were slaughtered, by order  
 of the Board of Agriculture, in the  
 counties of Lancaster, London,  
 Middlesex, Northumberland, and  
 York (West Riding), in England;  
 Aberdeen, Forfar, and Mid-Lothian,  
 in Scotland. In addition to the  
 above, 735 healthy cattle, which  
 had been in contact with the dis-  
 eased animals or otherwise exposed  
 to the risk of infection, were  
 slaughtered by order of the Board,  
 as were also eight cattle suspected  
 of being affected, but which were  
 found on post-mortem examination  
 to be free from pleuro-pneumonia,  
 although suffering from other forms  
 of lung disease. Three outbreaks,  
 involving nearly 400 cattle, were  
 reported within a few days of each  
 other. The first of these was on  
 the Knavesmire, at York; the  
 second in the county of Middlesex;  
 and the third in London.

SWINE-FEVER.—This disease still  
 continues widely spread, and more  
 or less prevalent in nearly every  
 county in England. The fresh out-  
 breaks have recently been about

180 per week, while the number of swine attacked weekly has been rather over 1,000, about half of which have been slaughtered; the greater part of the remainder died; a few recovered; but week after week some 600 or more diseased pigs have been left alive, actively reproducing the virus of the disease to infect others.

#### **Pleuro-Pneumonia.**

The Earl of FEVERSHAM said he wished to refer to the large number of cattle which from time to time were reported from the Veterinary Committee as having been slaughtered in consequence of outbreaks of pleuro-pneumonia. He thought it would be very desirable if they could have—and no doubt it was given in some form, probably by the Government—statistics from time to time as to the number of healthy cattle, as well as cattle affected with the disease, that had been slaughtered in the country. He knew that compensation was given by the Government, but at the same time it was a serious loss to the country. It was desirable that they should not only have monthly reports, but quarterly or half-yearly returns.

Mr. DENT stated that 8,000 animals had been slaughtered by order of the Board of Agriculture in six months; 150,000*l.* had been paid in compensation, of which only 60,000*l.* had been secured as salvage. He was glad to find that the views he had held for many years were beginning to receive some support, and was charmed to think that the President for next year was so seriously alarmed. The Board of Agriculture appeared determined to "stamp out" the disease of pleuro-pneumonia by killing all the cattle in the country. On the Knavesmire 263 animals reported to be affected with the disease were slaughtered, yet only one was said to be affected with pleuro-pneumonia. In the neighbourhood of Ripon seventy-nine animals were slaughtered, of which only one was reported to be affected. It was really a very serious matter. Most of the animals killed were heifers or cows in-calf. One friend of his had sixteen cows under experiment for cross-breeding, every one of which

was slaughtered in-calf. Fourteen others, four-year-old milch cows, nearly due to calve, had also been ordered to be slaughtered. What encouragement was there to farmers to breed stock if they were to run the risk of having all their breeding animals—cows and heifers—swept off in this wholesale fashion? He (Mr. Dent) had been in a minority of one for a long time; but he was very delighted to think that he would have a recruit in the person of the President. Before long there would be a tremendous outcry on the part of breeders and farmers in England at the sacrifice that was being made. They must not have the idea that they were going to stamp out the disease by slaughtering. Comparatively no impression was being made upon the centres of the disease, notwithstanding the rate at which cattle were being slaughtered at the present time.

Lord FEVERSHAM explained that he did not wish Mr. Dent to think that he was opposed to the system of slaughter. He should like some statistical account showing the extent of the disease—if the monthly reports could be condensed into one return for the six months.

Sir JOHN THOROLD, in answer to Lord Feversham, read the return which had been presented to the Veterinary Committee by Professor Brown on June 3, showing the number of animals killed between September 1, 1890, when the Pleuro-pneumonia Act came into operation, and May 23 last, from which it appeared that the number of diseased cattle slaughtered had been reduced, but the number of healthy cattle in contact slaughtered had been 8,012, as against 4,083 (see page lxxix).

Sir JACOB WILSON said he did not think his friend Mr. Dent ought to claim any credit for the part he had taken in the matter, or feel any great pleasure at the justification of the support he had given to the non-slaughter principle by what had taken place lately. But, on the other hand, he ventured to think that the Board of Agriculture might feel justified in what they had done, because they were quite within the estimate they laid before the House of Commons

last year, when they anticipated the possibility of everything that had taken place. It was impossible to stamp out pleuro-pneumonia in any specified period, in the same way as foot-and-mouth disease. If anybody would without prejudice read the report of the Departmental Committee upon that point, and the evidence given by those who had had the largest experience in this and other countries, they would come to the conclusion that no *guarantee* could be given of the disease being stopped within the period of the life of any animal alive, whilst pleuro-pneumonia was prevalent in this country. Even at the time of the passing of the Act, they knew that it must take at least two or three years. The Board were justified in their action by the evidence from Holland and elsewhere abroad. They knew what happened there. As soon as animals were turned out to grass they had no means of localising and isolating them as they had in winter, and so the disease was sure to spread. But if they waited for another period during the winter, when they could once more get them into their stalls, there would be a much better chance of dealing with the disease. It was not surprising that the disease should break out in a large enclosure like the Knavesmire. Few people cared about the matter until it affected themselves. He ventured to say that if they were to canvass the breeders in the showyard in contradistinction to the feeders of Irish cattle, and those who had unfortunately been at the Dublin Show, they would find that they were supporters of the policy adopted by the Board. Considering what had taken place in other countries, and after the experience they had gained, it would be deplorable if they failed to give the Board of Agriculture the support it deserved in the exertions it was making to get rid of the disease. (Applause.)

The report of the Veterinary Committee was then adopted.

#### Showyard Works.

Mr. FRANKISH presented the report of this Committee, including a statement of the Surveyor's accounts. The

Committee had authorised Mr. Bannison to include in the sale of wood after the Show the iron gates formerly used for the sheep pens.

#### Selection.

Earl CATHCART (Chairman), having read the recommendations of this Committee, moved the following resolutions:—

(a.) That Sir John Bennet Lawes, Bart., Vice-President, be transferred to the list of Trustees;

(b.) That Mr. H. Chandos-Pole-Gell be elected a Vice-President, in the room of Sir John Lawes;

(c.) That the Honorary Membership of the Society be conferred upon Monsieur Louis Passy, Secrétaire Perpétuel de la Société Nationale d'Agriculture de France, in recognition of the distinguished services which he has rendered to European Agriculture.

These resolutions were seconded by the Earl of FEVERSHAM, and carried unanimously.

Mr. CHANDOS-POLE-GELL, in reply, thanked the Council very sincerely for the honour they had done him, and said that he should use his best endeavours to forward the welfare of the Society as far as his powers would permit.

#### Nomination of a General Warwick Committee.

On the motion of Sir JACOB WILSON, seconded by Mr. FRANKISH, a General Warwick Committee was appointed, to consist of the whole Council, together with the following representatives, nominated by the Mayor of Warwick:—Lord Leigh, Lord Brooke, M.P., Lord Ernest Seymour, the Mayor of Warwick (Mr. J. W. Mann), the Town Clerk of Warwick (Mr. Brabazon Campbell), the Mayor of Leamington (Mr. Joseph Hinks), Major Fosbery, Mr. J. W. Margetts, and Mr. T. H. G. Newton, with Mr. Frederick H. Moore as Local Secretary.

#### Miscellaneous.

A letter from the United States Department of Agriculture asking for a

full list of pure breeds of horses, cattle, sheep, and swine, together with the names of the respective books of record established for each breed, was referred for consideration and report to the Stock Prizes Committee.

A communication having been received from the Charity Commission, stating that the scheme for the administration of the Seckford Hospital and Woodbridge Endowed Schools had been approved by Her Majesty in Council, it was resolved, on the motion of Mr. CHANDOS-POLE-GELL, seconded by Mr. SANDAY, that Mr. Alfred J. Smith, of Rendlesham, Woodbridge, be appointed the Society's Representative Governor, in accordance with Clause 6 of the scheme.

A variety of matters relating to protests and infringement of regulations having been considered, and directions thereon given to the Stewards and the Secretary, the Council adjourned until Wednesday, July 29 next, at 12 Hanover Square, at noon.

FRIDAY, JUNE 26, 1891.

#### Votes of Thanks.

At a Special Meeting of the Council held on the last day of the Show, June 26, it was unanimously resolved, on the motion of Sir JACOB WILSON, that votes of thanks for assistance rendered in connection with the Doncaster Meeting be given to Messrs. Beckett and Co., the Local Bankers of the Society; to the Borough Police; and to Messrs. Hall and Armitage, of New Wells, Wakefield, for the furniture used in the Royal Pavilion.

It was also resolved, on the motion of Sir JACOB WILSON, that letters should be written conveying the appreciation of the Council of the very efficient services rendered by (1) the detachment of the A Division of the Metropolitan Police, under command of Chief-Inspector Wren; (2) the officials of the St. John Ambulance Association, in charge of the Ambulance Station; (3) the officials of the Great Northern Railway for the facilities afforded by them.

WEDNESDAY, JULY 29, 1891.

THE EARL OF FEVERSHAM (PRESIDENT) IN THE CHAIR.

**Present:—**

*Trustees.*—Earl Cathcart, Colonel Sir Nigel Kingscote, K.C.B., Earl of Ravensworth.

*Vice-Presidents.*—Mr. H. Chandos-Pole-Gell, Sir John H. Thorold, Bart., Mr. C. Whitehead.

*Other Members of Council.*—Mr. G. M. Allender, Lord Brougham and Vaux, Mr. J. A. Caird, Mr. Percy E. Crutchley, Lieut.-Col. J. F. Curtis-Hayward, Mr. C. De L. F. De Laune, Mr. William Frankish, Mr. Joseph Martin, Mr. T. H. Miller, Hon. Cecil T. Parker, Mr. Daniel Pidgeon, Mr. James Rawlence, Mr. S. Rowlandson, Mr. G. H. Sanday, Mr. W. T. Scarth, Mr. A. J. Smith, Mr. Henry Smith, Mr. E. W. Stanyforth, Mr. Garrett Taylor, Mr. J. P. Terry, Mr. John Tremayne, Mr. R. A. Warren, Mr. E. V. V. Wheeler, Mr. C. W. Wilson, Sir Jacob Wilson.

Professor Brown, C.B.

*Officers.*—Mr. Ernest Clarke, Secretary and Editor; Dr. J. Augustus Voelcker, Consulting Chemist.

The following members of the Warwick Local Committee were also present:—Lord Brooke, M.P., Lord Ernest Seymour, the Mayor of Warwick (Mr. J. W. Mann), the Mayor of Leamington (Mr. Joseph Hinks), the Town Clerk of Warwick (Mr. Brabazon Campbell), Mr. T. H. G. Newton, and Mr. Frederick H. Moore (Secretary of the Local Committee).

**Apologies for Non-Attendance.**

Letters of apology for non-attendance were read from Viscount Emlyn, Lord Egerton of Tatton, Mr. Joseph Beach, Mr. C. Clay, Mr. John Dent, Mr. James Hornsby, and Mr. C. S. Mainwaring.

**Remarks by Retiring President.**

The minutes of the last monthly meeting of Council held on June 23, and of the Special Councils held

on June 25 and 26 in the Showyard at Doncaster, having been read and confirmed,

The Earl of RAVENSWORTH said he desired to take the opportunity, as the outgoing President, of expressing his high sense of the value of the services and assistance which had been rendered to him by the whole of the Society's staff. He wished to express his gratitude to Sir Jacob Wilson, to the Secretary, and to the whole of their admirable staff for the assistance which they had rendered to him during his year of office as President. (Hear, hear.)

**Election of New Governors and Members.**

The election of the following three Governors and eighty Members was then proceeded with:

*Governors.*

ASHWORTH, Charles E...The Heath, Knutsford.  
BEDFORD, Duke of...Woburn Abbey, Beds.  
NORFOLK, Duke of, K.G...Norfolk House, S.W.

*Members.*

ARKWRIGHT, J. P...Hutton House, Warwick.  
ASHLEY, Rt. Hon. E...Broadlands, Romsey.  
BICKLEY, E. K...Ellesmere, Salop.  
BOLTON, Rev. J. B...Badsworth, Yorks.  
BRAGG, D...Southwaite Hall, Carlisle.  
BRETT, H...Londonthorpe, Grantham.  
BROCKLEHURST, H. D...Acomb Hall, York.  
BRYDON, J...Millburn, Darlington.  
BUTTERFIELD, R...Nafferton Hall, Hull.  
CHAPMAN, P. N...Moor Hall, Leamside, Durham.  
CHEETHAM, W. J...Rawdon Hill, Arthington, Leeds.  
CLAYTON, P...Bosley, near Congleton.  
COOTE, S. V...Betaghstown, Naas, Co. Kildare.  
COTES, Col. C. James...Pitchford, Shrewsbury.  
COTTON, Col. the Hon. R. S...Somerford, Brewood, Staffs.  
CROMAR, John, Kirklington, Southwell.  
CURL, Thomas...Sedgeford, Lynn.  
CURTES, T...Park Hill, Swallownest, Rotherham.  
DAWSON, R...8 Duke Street, St. James's, S.W.  
DEWHURST, G...Radholm Laund, near Clitheroe, Yorks.  
DIMOCK, J. D...Soham, Cambs.  
DOBSON, A...Williamsgill, Temple Sowerby, Penrith.  
DOYNE, C. M...Wells, Gorey, co. Wexford.

FITZGERALD, W. H. W...Chacombe, Banbury.  
 FULLERTON, J. S. H...Thrybergh Park,  
 Rotherham.  
 GODFREY, E...Owston Ferry, Rotherham.  
 GRANT, A. H...Monymush, Aberdeenshire.  
 HALKON, W...Luddington, Lincs.  
 HARRISON, W...Beckingham, Gainsborough.  
 HARVEY, G. W...Londonthorpe, Grantham.  
 HATHAWAY, J., jun...Shenstone Pk., Lichfield.  
 HEAP, H. R...Ciltalgarth, Bala.  
 HEATON, F...Stetchworth Park, Newmarket.  
 HEATON, R. G...Chatteris, Cambs.  
 HINCHCLIFF, J...Skelmanthorpe, Huddersfield.  
 HINCHCLIFF, W...Skelmanthorpe, Huddersfield.  
 HINE, J. H...Pomphlett Farm, Plymstock,  
 Devon.  
 HOLLAND, W...Broken Cross, Macclesfield.  
 HOOD, S. F...Nettleham Hall, Lincoln.  
 HOWSEN, D...24, Albert Road, Southport.  
 HUGHES, G. M...King's Wick, Sunninghill,  
 Ascot.  
 HUNT, A...The Grange, Croydon.  
 HUTCHENCE, J...Royal Albert Farm, Lancaster.  
 INGLEYBY, John...Tadcaster, Yorks.  
 KAY, H. M...Whalley, Lancs.  
 KAYE, J...153, Stafford Street, Sheffield.  
 KNIGHTS, Robert, Harleston, Norfolk.  
 LAKE, F. C...Rayne Foundry, Braintree.  
 LEA, J. S...Far Forest Vicarage, Rock,  
 Bewdley.  
 LEACOCK, J. M...13, Courtfield Rd., S. Ken-  
 sington, S.W.  
 LEES, E., M.P...South Lytchet Manor, Poole.  
 LEES, W. R...Heathcote, Warwick.  
 LESLIE, Major John...Kiltybegs, Carrickma-  
 cross, co. Monaghan.  
 LIVERSIDGE, H., junr...Partington Hall,  
 Howden.  
 LOYD, E. H...Langleybury, King's Langley.  
 LOYD, Mrs. Lewis...Monk's Orchard, West  
 Wickham, Kent.  
 MACKERETH, H...Ashton-with-Stodday, Lan-  
 caster.  
 MERCER, T...Tithebarn Farm, Kirkby,  
 Liverpool.  
 MOORE, T...Spenn Moor Farm, Radcliffe, Man-  
 chester.  
 PENROSE, W...Camoyball Street, Helston.  
 PIERSON, C. E...59, Cadogan Square, S.W.  
 POTT, G., junr...c/o Watson, Laidlaw, and Co.,  
 Glasgow.  
 REPTON, G. G...Odell, Bedford.  
 ROSE, J. W...Aughton, Rotherham.  
 SACRÉ, H. M...Gorstella, Broughton, Chester.  
 SELBY, J...Epworth, via Doncaster.  
 SESSIONS, H...Russell House, Gloucester.  
 SIMPSON, J. M...Blackden House, Holmes  
 Chapel, Cheshire.  
 SMITH, J. H...Brierley Hill, Dudley, Worcester.  
 SOUTHERN, J...Weeford Park, Tamworth.  
 STRICKLAND, W. A...Abbey Farm, Whalley,  
 Lancashire.  
 TALBOT, Miss...Margam Park, Port Talbot,  
 Glamorgan.  
 THORNLEY, H. E...Radford Hall, Leamington.  
 TORR, G. C...West Carr, Thorne, Doncaster.  
 VICKERMAN, J...Fairlea House, Huddersfield.  
 WADE, E...Brantingham Thorpe, Brough,  
 Yorks.  
 WATANABE, H...Ushigome, Shirokanecho No.  
 29, Tokio, Japan.  
 WHILEY, H...Town Hall, Manchester.  
 WILSON, G. H...Eryl Anan, Bala.  
 WRIGHT, T...Haylebarrow Farm, Norton,  
 Sheffield.

Sir NIGEL KINGSCOTE said that the Council would observe amongst the list of new Governors the name of the Duke of Bedford, and would be gratified to learn that his Grace had taken up the Governorship of the Society which had been held by the head of the House of Russell ever since the Society was founded in 1838. The Council would be aware that his Grace had (when Marquis of Tavistock) expressed a wish at the end of last year to retire from his position as a Member of the Council. They had all received that announcement with extreme regret; but it had not, for obvious reasons, been possible to approach his Grace with a request to withdraw his resignation until his recent return to public life. He (Sir Nigel) had, however, written to the Duke within the last few days, expressing the very strong wish of the Council that his Grace would consent to remain a member of their body; and he was happy in being able to inform the Council that the Duke had written to say he placed himself in their hands, and would be most glad to put his services at the disposal of the Society in any way they might think fit. (Hear, hear.)

Earl CATHCART (Chairman of the Committee of Selection) expressed the pleasure of the Committee, and he was sure of the Council generally, at learning that through the good offices of Sir Nigel Kingscote, to whom they were greatly indebted for his action in the matter, the Society would continue to have the advantage of the association with it of the Duke of Bedford, both as a Governor and as a Member of Council. Under any circumstances the Council would desire to retain his Grace as a member of their body, but there was a special reason why the Duke should sit at that board, in view of his munificence in connection with the Woburn Experimental Farm.

The reports of the various Standing Committees were then presented and adopted, as below:—

#### Finance.

Sir NIGEL KINGSCOTE (Chairman) reported that the accounts for the

<sup>1</sup> Reinstated under Bye-law 12.

month ended June 30, 1891, as certified by the Society's accountants, showed receipts amounting to 2,241*l.* 19*s.* 11*d.*, and expenditure to 7,476*l.* 11*s.* 9*d.* The balance at the Bankers' on June 30, allowing for cheques outstanding, was 2,053*l.* 9*s.* 3*d.* The accounts for the period ended July 25, 1891, were also presented. They showed receipts amounting to 11,836*l.* 8*s.* 2*d.*, and expenditure to 1,886*l.* 9*s.* 9*d.*, with a balance at the bank, allowing for cheques outstanding, of 12,005*l.* 7*s.* 8*d.* Accounts relating to the recent Doncaster Meeting, amounting in all to 11,671*l.* 6*s.* 4*d.*, and relating to the ordinary business of the Society, amounting to 3,083*l.* 0*s.* 4*d.*, had been passed, and were submitted for payment. The quarterly statement of subscriptions, arrears, and of the Society's property had been laid upon the table. The Committee recommended that the names of one Foundation Life Governor (Mr. Frederick W. Calvert, Q. C., elected a member on February 13, 1839), eight life members, and twenty-nine annual members who were deceased, seven whose subscriptions were in arrear, and thirty-nine who had resigned (eighty-four in all) be struck off the Society's books; also that three members be reinstated under Bye-law 12.

On the motion of Sir NIGEL KINGSCOTE, it was unanimously resolved:—

That, in view of the desirableness of winding up the accounts of the Doncaster Meeting as early as possible, authority be given to the President, the Chairman of the Finance Committee, and the Secretary to issue, during the recess, orders on the Society's Bankers for the payment of accounts connected with the Meeting, such accounts to have been previously submitted to and passed by a Steward of Finance.

#### House.

Sir NIGEL KINGSCOTE (Chairman) presented the recommendations of this Committee as to the various repairs and the repainting of the Society's offices. Mr. Walter Gilbey had been added to the Committee.

#### International Congress of Hygiene.

Sir NIGEL KINGSCOTE asked that he might be allowed at that juncture to draw the attention of the Council to the International Congress of Hygiene, which was to sit in London the week after next. As the Council might be aware, he had undertaken the duties of President of one of the Sections—viz., "The Relations of the Diseases of Animals to those of Man," in which papers of great value and interest to agriculturists would be read. Copies of the programme had been laid upon the table, and he need hardly say that they should welcome the presence at their discussions of any member of the Council or of the Society.

#### Journal.

Earl CATHCART (Chairman) presented the recommendations of this Committee as to various payments in connection with the printing of the Journal, the Doncaster catalogue and awards, miscellaneous printing, stationery, books, &c. The Committee recommended that Mr. Whitehead's article in the current number of the Journal on "Methods of Preventing and Checking the Attacks of Insects and Fungi" be reprinted, and issued by the Society as a sixpenny pamphlet. William Chisholme having been recommended by the Judges of Farms for a certificate of distinguished merit in the discharge of his duties as shepherd for twenty-six years on the farm of Mr. T. H. Hutchinson, the Committee recommended that the usual certificate be awarded to him, accompanied by a gratuity of 2*l.* The Secretary had submitted a list of prizes proposed to be given by the Warwick Local Committee for Farms, in connection with the Country Meeting of 1892, together with the draft regulations. These had been considered, and referred to the General Warwick Committee. The proposed arrangements for the next number of the Journal had been considered and approved. An application for free copies of the Journal from the Division of Records and Editing of the United States Department of Agriculture had been granted. The Committee had approved of



various purchases which had recently been made for the Society's library, including a first edition of Jethro Tull's "Horse-hoeing Husbandry" (A.D. 1733), Wren Hoskyns' "Talpa," "A Short Inquiry into the History of Agriculture," and "Occasional Papers," and Pontey's "Forest Pruner."

#### Chemical.

Mr. WARREN presented the report of this Committee, which dealt with various matters of detail in connection with the Society's Laboratory and Chemical Department, and also the usual Quarterly Report of the Committee. The Committee recommended that the Duke of Bedford be added to the Woburn Sub-Committee.

On the motion of Mr. WARREN, seconded by Mr. WHITEHEAD, the Quarterly Report was received and adopted, and ordered to be published in the usual manner (see page 631).

#### Seeds and Plant Diseases.

Mr. WHITEHEAD (Chairman) stated that the report of the Sub-Committee on potato experiments had been received and adopted. This report announced that two dressings of sulphate of copper had been applied to the experimental plots at each of the six stations: the first dressing from June 29 to July 13, and the second from July 15 to July 27. Experiments were being conducted on two of the plots, viz., Cardington and Sittingbourne, with various strengths and quantities of the sulphate of copper mixture, with the view of ascertaining the effect upon the plots so treated. In one case, at Cardington, an experiment with sulphate of iron instead of sulphate of copper had been added. Sir Jacob Wilson had attended the Committee, and submitted specimens of swedes infested with the caterpillars of the Diamond-back Moth (*Cerostoma xylostella* C.), and reported a great amount of damage to turnip crops in his county through the ravages of this insect. He stated some of the measures which had been adopted against it, amongst which a mixture of soot and lime, applied dry, appeared to be the most efficacious. A report on the same subject had

been also received from Mr. Hornsby. Miss Ormerod had presented her report, which the Committee recommended should be published with the proceedings of the Council (see page 595).

#### The Diamond-back Moth Caterpillar.

Mr. WHITEHEAD said that Miss Ormerod's usual monthly report was on this occasion peculiarly interesting on account of the details which it gave of the new and unprecedented attack of the Diamond-back Moth in various eastern parts of England and Scotland. The report gave details of the outbreak, it described the history of the insect, and it gave practical suggestions as to the means of preventing and checking its ravages. Miss Ormerod pointed out that this was almost a new attack in England. Curtis in his "Farm Insects" spoke of it as happening forty years ago, in 1853 and 1854. It was also dangerous in some comparatively small degree in England and Scotland; but never before had there been such extraordinary damage caused by this insect as it was reported to have done, and unhappily was still doing, in the eastern parts of England and Scotland. Broccoli, cabbages, swedes, turnips, cauliflowers, being cruciferous plants, were all attacked. One gentleman had written from St. Andrews, Fife, that his wallflowers (which are also cruciferous plants) had been attacked too. At the present time the attack was entirely on the eastern coast. It had been suggested that the moths had been driven from foreign countries by the wind; others, with more probability, suggested that they had been enticed by the cruciferous plants, which were generally found on the sea-shore, and therefore they appeared in these myriads. The remedy suggested by Miss Ormerod was to put powdered soot and lime on the plants when the dew was upon them. Other remedies had been suggested and carried out. Mr. Hornsby had stated, in an admirable report which he had presented to the Seeds and Plants Committee, that dry materials, chiefly soot and lime, in the proportion of three parts of soot and one of lime, put on by the strawsonizer (whose powerful fan seemed to drive the

powder right into the plants) had proved the most efficacious. This was a most important point, because these caterpillars got in between the tissues of the plants, and unless the powder was driven forcibly against them it had not the power of checking the attack.

Sir JACOB WILSON said that, as his name was mentioned in the report of the Seeds and Plants Committee in connection with the insect now ravaging the turnip crops, probably he might be permitted to say a few words. It was something like three weeks ago since his attention was first directed to this matter. The caterpillars were found upon a turnip crop immediately adjoining the sea shore on the east coast of Northumberland upon very strong land at Goswick, near Beal. His advice at this time was that where the turnips were comparatively young the best treatment would be an immediate dressing of nitrate of soda, with some superphosphate to give vigour to the plant. From a letter he had received that morning, he was glad to find that this treatment had had a good effect. The letter stated that turnips dressed with nitrate and superphosphate seemed to be doing fairly well, the roots were swelling in spite of the attack, and the caterpillars were now disappearing, and perhaps a good rain would drive them off altogether. That was satisfactory as far as it went. Extensive experiments had been made elsewhere in the hope of discovering something to destroy these caterpillars. Anything more deplorable than the effects of the attack during the last week or fortnight he could not conceive. There had been every prospect of a large crop of turnips in Northumberland: now in many cases it was a waste desert, presenting the appearance of a field of gossamer. It was only in the case of the younger plants that they could hope to save a crop at all. He believed that if the turnips could be dressed immediately after they had been thinned, much good might be done. At this stage, and owing to a loss of support, the plant fell somewhat on to its side, making it possible to catch the turnip both above and below the level. The result of experiments

with paraffin and soapsuds, and lime afterwards, went to show that the dry dressing was much more efficacious than the wet dressing. Lime was the basis of the treatment they would have to adopt. The best, he believed, was in the proportion of one part of lime to three parts of soot, because the soot gave also some renewed vigour to the young plant. He believed that a great deal of the turnips would have to be ploughed up. The great question for the farmers was, What was to be done with the land? They must either sow late turnips or rape. Both those plants, being cruciferous, were equally liable to the attack of this caterpillar, therefore it was a very serious question indeed as to what they should do with their land. The results were simply ruinous. He had information that morning that the sale of lambs in the north during the last few days had been very seriously affected. Before this outbreak it was likely that they would fetch high prices in consequence of the prospects of a good crop of turnips. This was an opportunity not to be missed by the Department, which was authorised to look after the interests of agriculture. He believed that the Board of Agriculture would rise to the occasion, and not miss the opportunity of investigating this matter, and thus do a little for the British farmer. He would suggest that the Council should not leave that room without expressing their opinion that the Board of Agriculture should be invited to investigate this subject. He ventured, therefore, to submit for their consideration the following resolutions, which he trusted the Council would see their way to pass unanimously, with the view of strengthening the hands of the Board of Agriculture:—

1. That this Council learn with extreme concern of the serious losses to agriculturists incurred by the ravages of the Diamond-back Moth on turnips, swedes, and other crops, and beg to express an earnest hope that the Board of Agriculture will institute an immediate and complete inquiry into the causes of the outbreak, and into the steps which should be taken to prevent its spread.

2. That a copy of the above resolution be forwarded to the Board of Agriculture, with a promise of any assistance which the Society and its officials can afford in making the inquiry suggested.

Earl CATHCART suggested whether inquiry should not be made as to whether a similar attack had taken place in Continental countries, such as Holland and Belgium.

Sir JACOB WILSON said that along their sea coast a curious phenomenon had been observed. Within a mile of his own place the road had been covered with a shower of these white moths.

Mr. GARRETT TAYLOR seconded Sir Jacob Wilson's resolution, and gave particulars of an outbreak at Corton, near Lowestoft, where 200 acres of swedes had been completely destroyed. In an attack upon his own farm, he had applied a dressing of paraffin with nitrate of soda afterwards and superphosphate. They had had some heavy rain, and he thought his crops would get over it.

The Earl of RAVENSWORTH thought it might be of interest, and possibly of use, if he gave one or two historical data in regard to this matter. It seemed that this moth first appeared in 1851, when it spread from Essex to Belfast, in the North of Ireland. It then appeared again in 1863. Then there was a lapse of twenty years between that outbreak and the subsequent outbreak, which appeared in 1882. And now, in 1891, they had this very serious outbreak again. These were historical facts, which he believed could be tested. He would refer to what had been written on a previous occasion—viz., a work entitled "*Insecta Britannica*" (1854), by a gentleman named Stainton. It was from that source that the information was derived that the attack spread from Essex to the North of Ireland. He observed that Mr. Donkin, a gentleman well known in Northumberland, stated that it was very prevalent and doing great injury in the Vale of the Coquet, a long way from the sea. There was great doubt about the effect of any application as a remedy. There seemed to be an animal provided by nature itself which affected the grub. He

thought it would be very interesting if they could ascertain whether this parasite was found upon the caterpillars or moths.

Sir JACOB WILSON's resolutions were passed unanimously, and copies ordered to be sent to the President of the Board of Agriculture.<sup>1</sup>

Mr. WHITEHEAD thought he might say, without any breach of confidence, that the Board of Agriculture were intensely interested in this very important matter. The President was particularly interested himself in it, and was taking every possible pains to devise some means of increasing their knowledge of the subject, and to find some remedies for checking the present attack. The Board had already in hand a leaflet giving a full history of the insect and the methods of checking its progress, which would be distributed that

<sup>1</sup> The following is a copy of the reply of the Board of Agriculture, dated July 30, 1891:—

Sir,—I am directed by the President of the Board of Agriculture to acknowledge your letter of yesterday's date, conveying resolutions adopted by the Council of the Royal Agricultural Society of England, expressing a hope that the Board will institute an inquiry into the causes of the appearance of the Diamond-back Moth, and of its ravages on turnips and other crops, and into the steps which should be taken to prevent its spread, and offering the assistance of the Society and its officers in carrying out the same.

In reply, I have to inform you that the Board have already directed an inquiry to be made in those districts where the Diamond-back Moth has been most prevalent, viz.:—Norfolk, Lincolnshire, Yorkshire, Northumberland, the Litchians, Fifeshire, and Forfarshire. The inquiry has already commenced, and reports from those districts are expected very shortly. The Board have also given instructions that experiments shall be conducted in some of the worst districts, and they will be commenced in Norfolk and Northumberland, it is hoped, not later than Saturday next, and in other districts subsequently if it should be necessary.

From all the information which has at present reached the Board the ravages of the pest appear to be unusually serious in the districts which have been affected, and at present but little seems to be known either as to its origin or the remedies which can be most efficaciously applied.

I am to ask you to convey to the Council of your Society the thanks of the President for their offers of assistance in dealing with this matter, of which he will readily avail himself should the necessity arise.

I am, Sir, your obedient servant,  
(Signed) RICHARD DAWSON,  
Assistant Secretary.

The Secretary,  
Royal Agricultural Society of England.

afternoon throughout the whole of the infested districts by means of the Post Office. Inspectors were being appointed who would be instructed to visit the infested places, and make elaborate reports of the outbreak, adding methods of prevention and remedial measures which might have been found successful. He could assure the Council that every effort would be made by the Board of Agriculture on that occasion. With regard to what fell from Lord Cathcart, he (Mr. Whitehead) did not believe that those moths were driven across the sea. The information which Lord Ravensworth had given was very interesting, and he was very much obliged to the noble Lord. The Board of Agriculture would be especially grateful to the members of the Council for intelligence as to where the attack existed (naming, if possible, the individual parishes), in order that they might make inquiries, and give every possible information.

The subject then dropped, but the Secretary was instructed to afford all possible assistance to the officials of the Board of Agriculture in the inquiry about to be instituted.

#### Veterinary.

Sir JOHN THOROLD (Chairman) presented the following report from Professor Brown:—

**PLEURO-PNEUMONIA.**—During the ten months from September 1, 1890, when the Pleuro-pneumonia Act came into operation, to the end of June 1891, 240 outbreaks of this disease were dealt with by the Board of Agriculture; 11,452 cattle were slaughtered, of which 1,036 were found affected with the disease.

In the corresponding period of 1889-90 there were 291 fresh outbreaks; 6,891 cattle were slaughtered by the local authorities, of which 1,493 were said to have been affected with the disease.

In the three weeks ending July 18 there were twenty-four fresh outbreaks reported; 807 cattle were slaughtered by order of the Board of Agriculture, of which forty-five were diseased.

The recent increase in the amount

of pleuro-pneumonia is chiefly, if not entirely, due to infected or diseased cattle sold by a dealer in Southampton, and distributed all over England. The Board of Agriculture have traced and slaughtered over 150 cattle sold by this man since the beginning of the year, with the result that pleuro-pneumonia has been found among them on no less than thirteen different premises.

**ANTHRAX.**—During the four weeks ended July 18 there were twenty-one fresh outbreaks of anthrax in Great Britain, in the counties of Devon, Essex, Kent, Lancaster, Leicester, Lincoln, Salop, Somerset, Suffolk, Sussex, and York (West Riding), in England; and Aberdeen and Dumfries, in Scotland. Of twenty-eight animals attacked, one was killed and the remainder died.

**SWINE FEVER.**—This disease still continues to be very prevalent in many parts of England; there were 633 fresh outbreaks in the four weeks, and 3,615 pigs were attacked, 1,813 diseased pigs were killed, 1,332 died, 377 recovered, and 767 remained alive when the last published weekly return was made up.

A letter, dated July 14, had been read from the Governors of the Royal Veterinary College stating, in reply to the Society's communication on May 7 last, that on notice being sent to the College of any outbreak of abortion in cattle, a special investigation would at once be undertaken, and suggesting that the members of the Royal Agricultural Society should be invited to notify the Principal of the College of any outbreak of the disease occurring among their cattle, so that he might immediately be able to institute an inquiry. The Committee desired to direct the attention of members of the Council and of members of the Society to this communication, and to point out that the cost of any investigation which might be undertaken would be borne by the College. A letter was read from Mr. Walter Gilbey, tendering his resignation as one of the Society's six representatives upon the General

Registration Committee of the Worshipful Company of Farriers, in consequence of the pressure of other engagements. The Committee recommended that Mr. Gilbey's resignation be accepted with regret. At the request of the Committee, Sir Nigel Kingscote had undertaken to act as one of the Society's representatives upon the Registration Committee, in succession to Mr. Gilbey.

The Committee were of opinion that a horse-shoeing competition should be held in connection with the Warwick Meeting of 1892, limited to shoeing smiths in District F, consisting of the counties of Gloucester, Hereford, Monmouth, Salop, Stafford, Warwick, Worcester, and of South Wales. The Secretary having reported that the issue was exhausted of Professor Brown's pamphlet on the Structure of the Horse's Foot and the Principles of Shoeing, the Committee recommended that it should be reprinted after revision by the author.

#### Stock Prizes.

Mr. SANDAY (Chairman) reported that the Committee had further considered a protest made in respect of a Shire stallion exhibited at Doncaster, which at the Council meeting held in the showyard on June 22 was referred to the Shire Horse Society. A letter was read from the Shire Horse Society stating that they had investigated the pedigree of the stallion in question, and were satisfied that the breed of the dam was incorrectly stated in the Stud-book, and that the entry had therefore been cancelled. It, however, remained for the Editing Committee to consider a corrected pedigree which had been submitted for the re-entry of the dam in Vol. XIII. Pending the decision of the Shire Horse Society, the Committee recommended that the cheque for the prize awarded to the animal be withheld.

A report, under Rule 41, had been read from Professor Brown on the subject of the special examination of Stallions at Doncaster, giving the following results:—

Sixteen Coaching stallions were examined, four of which were unsound. The diseases were ringbone and whistling.

Twenty-four Hackney stallions were examined, one of which was unsound.—Sidebones.

Five Pony stallions were examined.—All sound.

Twenty-four Shire stallions were examined, four of which were unsound.—Whistling and sidebones.

Fifteen Clydesdale stallions were examined, one of which was unsound.—Roaring.

Nine Suffolk stallions were examined, all of which were sound.

A question as to whether exhibitors should be made acquainted with the particular nature of the disqualification of their animals was considered, and it had been decided that the reason of disqualification should not be given. It had also been decided that in future Rule 41 should apply to brood mares as well as to stallions. The Committee recommended that in future no person who had been expelled from any breed society for fraudulent practices should be permitted to exhibit at the Society's Meetings. A resolution from the Hunters' Improvement Society offering gold medals for brood mares had been read, but the Committee were unable to recommend the acceptance of the offer. Several letters on the subject of fines imposed by the Stewards at Doncaster, and also for the non-exhibition of animals, had been read, and it was decided to enforce the regulations as to payment.

An application from the United States Department of Agriculture, asking for a full list of English pure breeds of horses, cattle, sheep, and swine, had been considered, and the Committee recommended that the following list of pure breeds as recognised by the Royal Agricultural Society of England be sent to the Department, with the name and address of the Stud- or Herd-Book Society of each breed, where such existed:—

HORSES.		
Thoroughbred,	Exmoor,	Cleveland,
*Hackney,	New Forest,	Shire,
†Ponies—	Welsh,	Clydesdale,
including	Shetland,	Suffolk.
English,	Highland,	
Dartmoor,	Coaching,	

\* To be classed as a Hackney, an animal must be over 14 hands.

† To be classed as a Pony, an animal must not exceed 14 hands.

CATTLE.

Shorthorn,	Loughorn	Highland,
Hereford,	(nearly ex-	Ayrshire,
Devon,	tinct),	Jersey,
South Devon	Red Polled,	Guernsey,
(or Hams.),	Aberdeen-	Kerry,
Sussex,	Angus,	Dexter Kerry.
Welsh,	Galloway,	

SHEEP.

Leicester,	Suffolk,	Somerset and
Border Leicester,	Cheviot,	Dorset
Cotswold,	Black-Faced	Horned,
Lincoln,	Mountain,	Dartmoor,
Kentish or Rom-	Herdwick,	Exmoor,
ney Marsh,	Lonk,	Welsh Moun-
Oxford Down,	Ryeland,	tain,
Southdown,	Devon Long-	Limestone,
Shropshire	wool,	Wensleydale,
Down,	South Devon	Clun Forest,
Hampshire	or Hams.,	Roscommon.
Down,		

PIGS.

Large White,	Small Black	Berkshire,
Middle White,	(Suffolk or	Tamworth.
Small White,	Essex),	

Mr. GARRETT TAYLOR gave notice that he would move at the November meeting that separate classes be given at Warwick for heifers calved in 1890 and 1891 in each of the following breeds, viz., Devon, Sussex, Welsh, Red Polled, and Guernsey.

Implement.

Mr. FRANKISH (Chairman) presented the recommendation of the Committee that a further trial of the mechanical milking machine, exhibited at Doncaster, should take place, and reported that the Committee agreed with the recommendation of the Judges, that Messrs. J. and H. Keyworth and Co.'s harvester and rear discharge binder should be further tried on Mr. Milnthorp's farm at Doncaster or elsewhere on wheat, barley, and oats. The report of the Judges of miscellaneous implements on the new implements entered for Doncaster had been considered, and directions given for withholding the deposit in cases of non-exhibition and absence of novelty or improvement. The Committee reported that seventy-two entries of ploughs for the competitive trials at Warwick next spring had been received from eleven competitors. The entries of two firms received too late had been declined. An application from the Northumberland Agricultural Association for the loan of the Society's dynamometer had been granted on the usual terms.

General Warwick.

The Earl of RAVENSWORTH reported that the Committee had had under consideration the date to be suggested for the holding of the Warwick Meeting of 1892, and had unanimously resolved that the Show be held from Monday, June 20, to Friday, June 24, the implement yard and dairy being open on the previous Saturday. The Committee had also considered the regulations for the prizes, amounting to 300*l.*, proposed to be offered by the Local Committee for the best managed Farms, any portion of which is in the County of Warwick, and had with some modifications approved them. The final date of entry for these prizes was fixed for Saturday, October 31, 1891.

The Regulations for the Farm Prize Competition had been fixed as follows:—

Farm Prizes in connection with Warwick Meeting.

CLASS 1. For the best managed arable and grass farm of over 250 acres, of which not less than one-third shall be arable. First Prize, 80*l.* Second Prize, 40*l.* Third Prize, 20*l.*

CLASS 2. For the best managed arable and grass farm of over 150 acres and not exceeding 250 acres, of which not less than one-third shall be arable. First Prize, 60*l.* Second Prize, 40*l.*

CLASS 3. For the best managed arable and grass farm of over 50 acres and not exceeding 150 acres. First Prize, 40*l.* Second Prize, 20*l.*

CONDITIONS OF ENTRY.

1. The competition in all three classes is limited to tenant farmers paying a *bond fide* rent for at least three-fourths of the land in their occupation.

2. In assessing the proportion of arable and grass land on the occupation, the Judges are instructed to consider as permanent pasture all land that has been laid down to pasture for ten years.

3. Competitors must enter for competition all the land in their occupation in the district.

4. Competitors must have had the land in their occupation for not less than two years.

5. The last day of entry is Saturday, October 31, 1891. The Entrance-fee is 1*l.* to members of the Society, and 2*l.* to non-members. Members of the Warwickshire Agricultural Society will be allowed to enter on the same terms as members of the Royal Agricultural Society.

6. Competitors are requested to send a tracing of the plan of their farms with their certificate of entry, and to have ready for the Judges on their first visit a correct list of the stock on their farms.

7. The Judges are instructed to take into consideration cases in which competitors occupy land when agents for their landlords, and are likely to derive undue advantage from that dual position.

8. The Judges will be instructed to withhold the prizes in the absence of sufficient merit in any of the competing farms.

9. The Judges will be instructed especially to consider—

1. General management with a view to profit.
2. Productiveness of crops.
3. Quality and suitability of live stock, especially that bred upon the farm.
4. Management of grass land.
5. State of gates, fences, roads, general neatness, and state of cottage or cottages so far as tenant is liable.
6. Mode of book-keeping followed (if any).
7. Management of the dairy and dairy produce, if dairying is pursued.
8. The duration of the tenancy.

10. The Judges are authorised to recommend to the Council the award of certificates to any really deserving persons employed on any of the competing farms for distinguished merit in the discharge of their duties, such recommendations to be accompanied by a certificate of good character and length of service from the competing farmer. The number of certificates so granted may not exceed three in the case of a farm entered in Class 1, two in the case of a farm entered in Class 2, and one in the case of a farm entered in Class 3.

#### **Date of Warwick Meeting, 1892.**

It was then formally moved by Sir JACOB WILSON, seconded by the Hon. CECIL T. PARKER, and resolved, that the Country Meeting of 1892 be held from Monday, June 20, 1892, to Friday, June 24, inclusive, and that the implement yard and dairy be open on the previous Saturday, June 18. The final dates for the receipt of entries for this Meeting were at the same time fixed as under:—*Implements, &c.*: Friday, April 1, 1892; post entries at double rates, Friday, April 8. *Live Stock, Poultry, and Produce*: Saturday, April 30; post entries at double rates, Thursday, May 12.

#### **Showyard Works.**

Sir JACOB WILSON (Chairman) reported that the whole of the buildings in the Showyard at Doncaster had been levelled to the ground, and a greater portion of the Society's plant removed to Warwick. Three days' sales of materials had been held, and the concluding sales would take place on the four last days of this week. The Surveyor had presented a plan of the Warwick Showyard, which had been approved.

Sir JACOB WILSON said he wished to express the great indebtedness of the Society to the Great Northern Railway Company for the readiness with which they met all the Society's requirements at Doncaster. They furnished the Society with a great deal of accommodation, not only in the supply of innumerable sleepers required in the Showyard but in many other matters. He thought the Council should specially recognise these endeavours on their behalf, and in addition to the formal vote of thanks passed in the Showyard, he begged to move a special vote of thanks to the Great Northern Railway Company for the great assistance rendered by them in connection with the Doncaster Meeting.

The Earl of RAVENSWORTH seconded this motion, which was carried unanimously.

#### **Selection.**

Earl CATHCART (Chairman) presented the recommendation of the Committee as to filling up the vacancy

on the Council caused by the election of Mr. Chandos-Pole-Gell as a Vice-President, and reported that letters of thanks had been received from Sir John Lawes and Monsieur Louis Passy for their election as Trustee and Honorary Member respectively.

#### Education.

Mr. PIDGEON submitted various recommendations of this Committee as to schemes under the Endowed Schools Acts, for which the Society was asked to nominate representative governors. The Committee had had under consideration the arrangements for the publication of the series of thirty coloured diagrams prepared by Miss Georgiana E. Ormerod, in conjunction with her sister, the Society's Consulting Entomologist, and recommended that they be published in five sets of six each: (1) Common insect attacks; Insects affecting (2) Various kinds of crops; (3) Particular crops; (4) Fruit crops; (5) Trees—at a cost of 7s. 6d. per set, or 12s. 6d. varnished and mounted on canvas, with roller: single diagrams being supplied at 1s. 6d., or 2s. 6d. mounted. It had been arranged that an allowance of 25 per cent. from these prices should be made to members of the Society. The diagrams would be issued through the well-known firm of map and diagram publishers, Messrs. W. and A. K. Johnston, of 5, White Hart Street, E.C., and Edinburgh, through whom could also be had (at 1s. each) Mr. Carruthers' new diagram on the potato disease, containing ten coloured illustrations of good and diseased potatoes and potato leaves, and descriptive letterpress, with hints for growers.

#### Dairy.

The Hon. CECIL T. PARKER (Chairman) reported that the Committee had considered a report from the Judges of milking machines at Doncaster, suggesting a further trial of Messrs. Nicholson and Gray's machine, and had referred it to the Implement Committee, with a recommendation that the suggestion should be carried out. Various details in connection with future arrangements for the produce and poultry classes had been considered.

#### International Agricultural Congress at The Hague.

The SECRETARY laid upon the table various documents relative to this Congress, which is to be held at The Hague from September 7 to 12 next, together with letters from eminent Dutch authorities, offering all possible facilities to any representatives of the Society who might be visiting the Congress. It was agreed that, in addition to the Secretary, any members of the Council who might be attending the Congress should do so as official delegates of the Society.

#### Suggestions at General Meeting.

The suggestions made by members at the general meeting in the Showyard at Doncaster as to railway accommodation were considered, and it was decided that no action could at present be taken with regard to them.

#### Country Meeting of 1893.

Invitations from the Corporations of CHESTER and MANCHESTER inviting the Society to hold its Country Meeting of 1893 in their respective cities were read, and the thanks of the Council therefor ordered to be sent. The further consideration of the invitations was deferred until after the autumn recess.

#### Miscellaneous.

Various letters were read from societies and others, thanking the Society for the use of the large tent in the Showyard. A communication from the Agricultural Engineers' Association in reference to Implement Exhibits was ordered to be referred to the Implement Committee for consideration.

#### Date of next Meetings.

The date of the general meeting of governors and members in December next having been fixed for the Thursday of the Smithfield week (December 10), at 20, Hanover Square, and the usual holidays having been granted to the Secretary and Clerks, the Council adjourned over the autumn recess until Wednesday, November 4, 1891, at noon.



# Proceedings at General Meeting of Governors and Members,

HELD IN THE LARGE TENT IN THE

SHOWYARD AT DONCASTER.

---

TUESDAY, JUNE 23, 1891.

THE EARL OF RAVENSWORTH (PRESIDENT) IN THE CHAIR.

---

*Present on the Platform :*

*Trustees.*—General Viscount Bridport, K.C.B., Earl Cathcart, Mr. John Dent Dent, Col. Sir Nigel Kingscote, K.C.B.

*Vice-Presidents.*—Mr. H. Chandos-Pole-Gell, the Earl of Feversham, Rt. Hon. Sir Massey Lopes, Bart., Sir John H. Thorold, Bart.

*Other Members of Council.*—Mr. G. Mander Allender, Mr. Alfred Ashworth, Mr. Joseph Beach, Mr. J. Bowen-Jones, Lord Brougham and Vaux, Mr. James A. Caird, Mr. Charles Clay, the Earl of Coventry, Mr. Percy E. Crutchley, Lieut.-Col. J. F. Curtis-Hayward, Mr. Alfred Darby, Mr. C. De L. Faunce De Laune, Viscount Emlyn, Mr. S. P. Foster, Mr. W. Frankish, Mr. Hugh Gorringe, Mr. James Hornsby, Mr. Charles Howard, Mr. C. S. Mainwaring, Mr. Joseph Martin, Mr. J. E. Ransome, Mr. Samuel Rowlandson, Mr. G. H. Sanday, Mr. W. T. Scarth, Mr. Alfred J. Smith, Mr. Henry Smith, Mr. R. Stratton, Mr. Martin J. Sutton, Mr. Garrett Taylor, Mr. C. W. Wilson, Sir Jacob Wilson.

*Members of Doncaster Local Committee.*—The Mayor of Doncaster (Mr. Alderman Stockil), Mr. Joseph Firth Clark, Mr. G. B. C. Yarborough, Mr. George Chafer (Secretary of the Local Committee).

*Officers.*—Mr. Ernest Clarke, Secretary and Editor; Dr. J. Augustus Voelcker, Consulting Chemist.

There was also in the tent a large attendance of the general body of Governors and Members.

### Awards of Farm Prizes.

The first business of the meeting was the opening of the sealed awards of the Judges of farms, which the SECRETARY read as follows:—

Class 1.—Arable and grass farm of 200 acres and upwards, of which not less than one half is arable:—

*First Prize, 50l.,* Teasdale H. Hutchinson, Manor House, Catterick.

*Second Prize, 30l.,* J. A. Staveley, The Manor House, North Dalton, Hull.

*Third Prize, 20l.,* James Townend, Newton, Doncaster.

*Commended, S. E. Parkin,* Melton Brand, Doncaster.

Class 2.—Arable and grass farm above 100 acres, and not exceeding 200 acres, of which not less than one half is arable:—

*First Prize, 50l.,* Andrew Merryweather, Whiston, Rotherham.

*Second Prize, 30l.,* John Stanley, Campsall, Doncaster.

Class 3.—Arable and grass farm above 40 acres, and not exceeding 100 acres:—

*First Prize, 50l.,* Tom D. Strickland, Carlton Miniott, Thirsk.

*Second Prize, 30l.,* W. Walsh, Gilstead, Bingley.

*Third Prize, 20l.,* Joseph and William Hinchcliff, Lady Oak Farm, Emley, Wakefield.

#### **Presentation of Stallion Medals.**

The PRESIDENT next presented the Gold Medals awarded by the Society through the Doncaster Local Committee to Mr. Thomas Carr for Crom-A-Boo, Mr. David Cooper for Linnæus, and Mr. E. Hodge Banks for Moss Hawk.

#### **Vote of Thanks to Mayor and Corporation of Doncaster.**

Earl CATHCART then said it was his very agreeable duty as Senior Steward of Stock to move, "That the best thanks of the Society be given to the Mayor and Corporation of Doncaster for their cordial reception of the Society." His Lordship said, as Senior Steward of Stock, he had been connected with the heavy-weights. He himself was only a light-weight, and he should find it difficult to carry upon his shoulders, metaphorically, the weight of obligation they were under to the Mayor and Corporation of Doncaster. To see the interest which Doncaster had taken in the Society, they had only to look at the decorations in the town on their way to the Showyard. He reminded them that they were on classic ground. If they could recall the shades of the grand horses that had appeared on the Doncaster race-course, they would have in their minds a noble procession. He had the honour to propose a vote of thanks to the Mayor and Corporation of Doncaster.

Sir W. GILSTRAP (Suffolk) seconded, saying he lived in a distant part of the country, and it was a great source of satisfaction to them that they could come to that great Meeting and have their exertions fructified by the Society. Every facility was given them in their visit, and he hoped that the Corporation would receive gratification from the

favourable circumstances of fine weather and a good Meeting.

The motion having been carried with acclamation,

The Mayor of DONCASTER (Mr. Alderman Stockil) returned thanks for the cordial manner in which the vote had been proposed and passed, assuring them that when it was first suggested, and when they knew, that the "Royal" of England was coming to Doncaster, they made up their minds to make the Meeting a great success. He thought the prospect they had before them was a sure sign that their exertions had been rewarded. But they had had most invaluable assistance from all the officials connected with them; and he would not be doing his duty to his colleagues if he did not bear testimony to the indefatigable exertions of their ex-Mayor (Mr. Joseph Firth Clark). He believed that all the town hailed the visit of the Society with pleasure. He could assure the Society that all their hopes would be realised if the Meeting were a great success to the Society itself. (Cheers.)

#### **Vote of Thanks to Local Committee.**

Mr. JAMES A. CAIRD, as Senior Steward of Implements, moved a vote of thanks to the Local Committee for their exertions to promote the success of the Meeting. The Local Committee had had a good deal of hard work, and they had done it uncommonly well. The ground had been well looked after, and it was to be hoped the Show would be a great success.

Sir JACOB WILSON seconded, saying that if he might add his own personal thanks to the Local Committee he should only be doing that which his heart dictated. In his capacity as Honorary Director it had been his duty to pay frequent visits there in making the arrangements for that great Meeting, and he could only say that, with the experience of a quarter of a century, he had never known their wishes more thoroughly anticipated.

The vote of thanks having been unanimously accorded,

Mr. G. B. C. YARBOROUGH, in reply, said that though their work had been

hard it had been comparatively light because the Society was so admirably organised. It had been a labour of love to all of them, from first to last. He hoped that at the end of the week the Council and the members of the Society would be so well satisfied that they would begin to think of paying them another visit before very long.

#### Suggestions by Members.

The PRESIDENT having put the usual inquiry as to whether any member had remarks to make or suggestions to offer for the consideration of the Council,

Mr. C. F. HOPE (York) referred to the railway facilities in connection with the Show, and complained that the Companies this year had refused to issue weekly contract tickets from places within two or three hours' run of Doncaster.

Mr. HENRY DE VITRE (Berks) asked if the Council were satisfied with the arrangements of the railway companies as to the conveyance of cattle. Beyond putting on a vacuum brake, the Great Western Company had done nothing to improve the accommodation for cattle traffic.

Mr. NATHANIEL BENJAFIELD (Dorset) said that the South-Western Railway had only six cattle vans, and they could therefore imagine the difficulty of getting one. He always thought the railway companies should be condemned instead of thanked.

#### Vote of Thanks to Retiring President.

Sir HENRY SIMPSON (Windsor) then moved that the best thanks of the Society be given to the Earl of Ravensworth for his services as President during the past year. He was sure that his resolution would be received with the same unanimity and enthusiasm as those which had been already presented to them. Lord Ravensworth had worthily sustained the reputation which previous presidents had made for the Society in whatever capacity he had been called upon to represent it.

Mr. FREDERICK REYNARD seconded, and the motion having been put by the SECRETARY, was declared unanimously amidst loud cheers.

The PRESIDENT, in reply, returned his most heartfelt and grateful thanks for the honour they had paid him. He wished to tell them all that whatever humble duties or services he had been able to perform had been most willingly undertaken. The real fact of the matter was that the post he had had the honour for a year to occupy was practically a sinecure. So admirable was the subdivision of labour between the members of Council, those admirable committees, and the eminent, practical, and business-like men who presided over them, that the duties of the President had been very light. No one, perhaps, had had a better opportunity than their President of knowing what the work of that great Society was. Having had a considerable experience of public life, he knew of no society, no body of public men in this country, who did so much useful work with such little expenditure of time and talk as the "Royal" of England. Of course no body of human beings could hope to please everybody, but what the Society had always attempted was to do its duty without favour or predilection. He congratulated them on account of the present prospects of the Show, which promised to be a very great success. They had been met in their arrangements by the Mayor and Corporation with that love of hard work which he believed characterised the North of England. He trusted that they would be able to set down the records of the old Town Moor of Doncaster as one of the most brilliant Meetings they had ever had. His Lordship concluded by renewing his expression of thanks for the honour that had been paid him, and by assuring them that any future services that he could render to the agricultural community of England would be most readily and heartily given. (Applause.)

#### President for 1891-92.

Mr. N. L. COHEN (Surrey) moved "That the Earl of Feversham do take the chair as President after the conclusion of the present Meeting." He thought that although some things in that exhibition might be the subject of criticism, the bulk of the members of the Society who attended its Shows

year by year must feel that, whatever were the locality chosen, the foresight of their officers, the wisdom of their Council, and the great public spirit invariably shown—inasmuch as it was the universal attribute of Englishmen—always ensured an indubitable success. Those attributes, that wisely-directed energy, and that public spirit could not be more happily illustrated than by the Earl of Feversham. They did not need that he should tell them that the Society might well be congratulated upon having for its chief next year a nobleman who was so competent to forward in any direction that which was decided by the wisdom of the Council.

Mr. ISAAC ROUCH (Middlesex) seconded, and the motion was carried unanimously.

The Earl of FEVERSHAM, who was received with loud cheers, thanked the meeting sincerely for the honour they had done to him. He esteemed it a very high honour to follow in the footsteps of those who had occupied that chair, and of his noble friend whom he had known for so long in both Houses of Parliament, and who, as President, had upheld the dignity and the position of that Society so well. He would not detain them upon that occasion, because he knew that they must be anxious to go into that famous Showyard, of which, he

thought, every member of the Society must be proud. If they wished to consider for a moment what the Society had done, the great work which it had accomplished, and which it was carrying on in the country, they had only to look round the Show, and he thought that the agriculturists and farmers of this country, and of that great county in particular, would find a lesson of the greatest service to them. Next year the Society would visit the ancient and famous town of Warwick, and he was happy to think that there was a connection between that great county of York and the county of Warwick. In Warwickshire at that moment they were famous for their breed of Shorthorns, and those Shorthorns were originally from the banks of the Tees. To compete with the cattle of that district Yorkshiremen would have to take the very best animals they could, and he hoped they would do so. They had seen some evidences of what Yorkshiremen could produce in the field that day. He thanked them for the distinguished honour they had done him, and he need not say how much he appreciated it.

The PRESIDENT then promised that attention should be given by the Council to the remarks that had been made on the subject of railway accommodation, and declared the business of the meeting at an end.

# DONCASTER MEETING.

JUNE 20 TO 26, 1891.

PRESIDENT :

**THE EARL OF RAVENSWORTH.**

Ravensthorpe Castle, Gateshead.

OFFICIALS :

**Honorary Director.**

Sir JACOB WILSON, Chillingham Barns, Belford, Northumberland.

**Stewards of Live Stock.**

Earl CATHCART, Thornton-le-Street, Thirsk.

C. S. MAINWARING, Galltfaenan, Trefnant, R.S.O., North Wales.

J. BOWEN-JONES, Emsdon House, Montford Bridge, Salop.

E. V. V. WHEELER, Newnham Court, Tenbury, Worcestershire.

**Stewards of Implements.**

J. A. CAIRD, Northbrook, Micheldever, Hants.

PERCY E. CRUTCHLEY, Sunninghill Park, Ascot.

DAN. PIDGEON, Walsingham House, Piccadilly, W.

**Steward of Dairying, Poultry, and Produce.**

The Hon. CECIL T. PARKER, Eccleston, Chester.

**Steward of Forage.**

CHARLES CLAY, Walton Grange, Wakefield.

**Stewards of Finance.**

W. FRANKISH, Limber Magna, Ulceby, Lincolnshire.

G. H. SANDAY, Langdale Lodge, Clapham Park, Surrey.

**Secretary.**

ERNEST CLARKE, 12 Hanover Square, London, W.

## JUDGES OF IMPLEMENTS.

**Implements, &c., competing for Prizes.**

*Class 1 (Threshing Machines).*

Col. GRANTHAM, West Keal Hall, Spilsby.

SAMUEL ROWLANDSON, Newton Morrell, Darlington.

WM. ANDERSON, C.E., D.C.L., F.R.S., Lesney House, Erith.

*Classes 2 & 3 (Cream Separators).*

R. NEVILLE GRENVILLE, Butleigh Court, Glastonbury.

T. RIGBY, Sutton Weaver, Cheshire.

J. AUGUSTUS VOELCKER, B.A., B.Sc., Ph.D., 12 Hanover Square, W.

*Class 4 (Milking Machines).*

R. NEVILLE GRENVILLE, Butleigh Court, Glastonbury.

THOMAS RIGBY, Sutton Weaver, *via* Warrington.

**Miscellaneous Implements.**

J. W. KIMBER, Fyfield, Abingdon, Berks.

W. J. MALDEN, Cardington, Bedford.

## JUDGES OF STOCK, &amp;c.

**HORSES.****Hunters.**—*Classes 2, 4, 6, 8, & 10.*

J. B. COOKSON, Meldon Park, Morpeth.

JOHN COOPER, East Haddon, Northampton.

Earl of LONSDALE, Barley Thorpe, Oakham.

**Hunters.**—*Classes 1, 3, 5, 7, 9, & 11.*

Earl of COVENTRY, Croome Court, Severn Stoke, Worcester.

J. MAUNSELL RICHARDSON, Ulceby, Lincolnshire.

**Coach Horses, and Harness Horses and Ponies.**—*Classes 12-18; 33 & 34.*

T. ROBSON, Wold House, Driffield.

C. W. WILSON, Rigmaden Park, Kirkby Lonsdale.

**Hackneys and Ponies.**—*Classes 19-32.*

ALFRED ASHWORTH, Tabley Grange, Knutsford.

JOSEPH MORTON, Stow, Downham.

GEORGE ROBSON, Shires House, Easingwold.

**Shire and Agricultural.***Classes 35-41; 54 & 55.*

HENRY BULTITAFT, Bedwell Hey, Ely.

EDW. GREEN, The Moors, Welshpool.

J. MORTON, West Rudham, Swaffham.

**Clydesdale.**—*Classes 42-48.*

ANDREW RALSTON, Glamis, Forfar.

JAMES WEIR, Sandilands, Lanark, N.B.

**Suffolk.**—*Classes 49-53.*

HERMAN BIDDELL, Hill House, Playford, Ipswich.

J. STURLEY NUNN, Rushbrooke, Bury St. Edmunds.

**CATTLE.****Shorthorn.**—*Classes 56-62.*

L. C. CHRISP, Hawkhill, Alnwick.

GEORGE DREWRY, Holker, Carke-in-Cartmel.

JAMES HOW, Broughton, Huntingdon.

**Hereford.**—*Classes 63-68.*

F. EVANS, Bredwardine, Hereford.

RICHARD S. OLYER, Trescowe, Bodmin.

**Devon and Sussex.**—*Classes 69-76.*

T. A. ABBOTT, Old Paddockhurst, Worth, Crawley.

RICHARD HAMSHAR, Bolney Place, Hayward's Heath.

S. P. NEWBERY, Plympton St. Mary.

**Welsh.**—*Classes 77 & 78.*

F. EVANS, Bredwardine, Hereford.

JOHN WILLIAMS, Gwernhefin, Bala.

**Red Polled.**—*Classes 79-82.*

CHAS. HOWARD, Biddenham, Bedford.

JOS. P. TERRY, Berry Field, Aylesbury.

**Aberdeen-Angus.**—*Classes 83-86.*

ROBERT WALKER, Altyre, Forres, N.B.

WILLIAM WHYTE, Hatton of Eassie, Meigle, N.B.

**Galloway and Ayrshire.***Classes 87-92.*

ANDREW ALLAN, Munnoch, Dalry.

ANDREW MONTGOMERY, Nether Hall, Castle Douglas, N.B.

**Jersey.**—*Classes 93-98.*

C. B. DIXON, Wood Hayes, Westridge Road, Southampton.

J. F. HALL, Sharcombe, Wells, Som.

**Guernsey.**—*Classes 99-102.*

C. MIDDLETON, Marton, Middlesborough.

J. W. MOSS, Feering, Kelvedon, Essex.

**Kerry and Dexter Kerry.***Classes 103-106.*

G. MANDER ALLENDER, Stammerham, Horsham.

JAMES E. BUTLER, Waterville, Co. Kerry.

**SHEEP.****Leicester, Cotswold, and Lincoln.***Classes 108-119.*

J. J. GODWIN, Troy Farm, Somerton, Oxon.

E. RILEY, The Weir, Hessle, Hull.

HENRY SMITH, The Grove, Cropwell, Butler, Notts.

**Oxford Down.**—*Classes 120-123.*

J. B. ELLIS, West Barsham, Walsingham, Norfolk.

N. STILGOE, Adderbury, Banbury.

**Shropshire.** (Rams).*Classes 124 & 125.*

JOSEPH BEACH, The Hattons, Wolverhampton.

P. A. EVANS, Sherlowe, Wellington, Salop.

**Shropshire.** (Ram Lambs and Ewes).

*Classes 126 & 127.*

J. E. FARMER, Felton, Ludlow.  
C. R. KEELING, Congreve, Penkridge.

**Southdown.**—*Classes 128-131.*

THOMAS FULCHER, Elmham Hall,  
Dereham, Norfolk.

HUGH GORRINGE, Kingston-by-Sea,  
Brighton.

**Hampshire and Suffolk.**

*Classes 132-139.*

M. ARNOLD, Westmeon, Petersfield.  
GEORGE PETTIT, The Firs, Friston,  
Saxmundham.

**Wensleydale.**—*Classes 140-143.*

ROBERT CARR, Catgill House, Skip-  
ton, Yorks.

JAMES PICKARD, Thoresby, Redmire,  
Yorks.

**Border Leicester.**—*Classes 144-146.*

W. FORD, Fenton Barns, Drem, N.B.  
ANDREW WOOD, Brocksbushes, Cor-  
bridge-on-Tyne.

**Cheviot.**—*Classes 147-149.*

JOHN ELLIOT, Hindhope, Jedburgh.  
H. H. SCOTT, Lesbury, Northumber-  
land.

**Black-faced.**—*Classes 150-152.*

ROBERT PATERSON, Birthwood,  
Biggar, N.B.

T. A. STEPHENSON, Newbiggen,  
Blanchland, Northumberland.

**Lonk and Herdwick.**

*Classes 153-158.*

JOHN INGLEBY, Austwick, Lancaster.  
JOHN IRVING, Shap Abbey, West-  
moreland.

**PIGS.**

**White.**—*Classes 159-170.*

JOHN ANGUS, Whitefield, Morpeth.  
JOHN BARRON, Borrowash, Derby.  
Captain HEATON, Worsley, Man-  
chester.

**Berkshire and Black.**

*Classes 171-178.*

JOHN A. SIM, Wootton, Wawen, Hen-  
ley-in-Arden.  
G. M. SEXTON, Stone Lodge, Ipswich.

**Tamworth.**—*Classes 179-182.*

JAMES R. RANDELL, Chadbury, Eve-  
sham.

JOHN A. SIM, Wootton, Wawen, Hen-  
ley-in-Arden.

**POULTRY.**

*Classes 183-280.*

D. BRAGG, Southwaite Hall, Carlisle.  
E. BROWN, 16 Woodberry Grove, N.

M. LENO, Cox Pond Farm, Hemel  
Hempstead.

J. W. LUDLOW, Vauxhall Road, Bir-  
mingham.

**PRODUCE.**

**Cheese.**—*Classes 281-288.*

WILLIAM KING, Beast Market Hill,  
Nottingham.

P. W. STONE, 105 Victoria Street, S.W.

**Butter.**—*Classes 289-291.*

GEORGE GIBBONS, Tunley Farm, Bath.  
JAMES HUDSON, Ludgate Hill, E.C.

**Cider and Perry.**—*Classes 292-295.*

WILLIAM GAYMER, Banham, Attle-  
borough.

**Jams and Preserved Fruits.**

*Classes 296-299.*

FREDERIC LAURENCE, 8 Somerfield  
Terrace, Maidstone.

**Hives and Honey.**—*Classes 300-314.*

Rev. J. F. BUCKLER, Bedston Rectory,  
Birkenhead.

W. B. CARR, Orpington, Kent.

JESSE GARRATT, Meopham, Kent.

WALTER MARTIN, Wainfleet.

**COMPETITIONS.**

**Farms.**

W. C. BROWN, Appleby, Doncaster.  
GARRETT TAYLOR, Trowse House,  
Norwich.

**Butter-making.**

GEORGE GIBBONS, Tunley Farm, Bath.  
T. RIGBY, Sutton Weaver, Cheshire.

**Horse-shoeing.**

J. D. BARFORD, F.R.C.V.S., 57 Above  
Bar, Southampton.

CLEMENT STEPHENSON, F.R.C.V.S.,  
Sandyford Villa, Newcastle.

**OFFICIAL REPORTER.**

W. FREAM, B.Sc., LL.D., 12 Hanover Square, London, W.

# AWARD OF PRIZES AT DONCASTER.

## ABBREVIATIONS.

I., First Prize. II., Second Prize. III., Third Prize, &c. B. N., Reserve Number. H. C., Highly Commended. Com., Commended.

Unless otherwise stated, each Prize Animal in the Classes for Horses, Cattle, Sheep, and Pigs was "bred by Exhibitor."

## HORSES.

### Thoroughbred Stallions.

*Winners of the Three Premiums of £200 offered by the Society, and the Special Gold Medals offered by the Doncaster Local Committee, at the SPRING SHOW, held at THE ROYAL AGRICULTURAL HALL, LONDON, March 3-6, 1891.*

- A. THOMAS CARR**, May House, Droitwich, for **Crom-A-Boo**, brown, foaled 1881; *s.* Camballo, *d.* Euphrosyne *by* The Miner, *g. d.* Gaily *by* Weatherbit; bred by J. Ridley, Manor House, Bedale. Has stood at Ripon, and travelled the district during the season of 1891.
- B. DAVID COOPER**, Bainesse, Catterick, Yorks, for **Linnaeus**, grey, foaled 1878; *s.* Strathconan, *d.* Sweet Violet *by* Voltigeur, *g. d.* Cowslip *by* Oxford; bred by A. Harrison. Has stood at Bainesse, and travelled to Bedale, Northallerton, Scotch Corner, and Richmond during the season of 1891.
- C. EDWIN HODGE BANKS**, Highmoor, Wigton, Cumberland, for **Moss-Hawk**, chestnut, foaled 1880; *s.* Blair Athol, *d.* Vergiss-mein-nicht *by* The Flying Dutchman, *g. d.* Forget-me-not *by* Hetman Platoff. Has stood at Driffield, and travelled the district during the season of 1891.

### Hunters.

- No. in Catalogue
- Class 1.—Hunter Mares and Foals.** [17 entries, 1 absent.]
- 16 **I. (£20).**—F. B. WILKINSON, Blyth Spital, Rotherham, for **Jessie 60**, bay, foaled 1877 [foal *by* Discord], breeder unknown; *s.* Bolivar, *d.* *by* Poynton.
- 6 **II. (£10).**—I. D. DUNN, Keyingham, Hull, for **Atalanta**, bay, foaled 1882 [foal *by* Southampton], bred by C. H. Hart, Dunnington Lodge, York; *s.* Cramoisi, *d.* Achievoment *by* Knowsley.
- 1 **III. (£5).**—FREDERICK BLENKIN, Burstwick Old Hall, Hull, for **Princess Beatrice 249**, chestnut, foaled 1883 [foal *by* Jarnac]; *s.* Bay President, *d.* Empress *by* Theobald.
- 17 **B. N. & H. C.**—F. B. WILKINSON, Blyth Spital, Rotherham, for **Petticoat**.  
**H. C.**—G. E. CLARKE for No. 3, **Lady Grey**; CAPT. JOHN DANBY for No. 4, **Melrose**; JOHN LETT for No. 9, **Coquette**.



[Unless otherwise stated, each prize animal named below was "bred by exhibitor."]

**Class 2.—Hunter Mares or Geldings, foaled in 1885 or 1886.<sup>1</sup>**  
[18 entries, 4 absent.]

WEIGHT CARRIERS UP TO 15 STONE.

- 19 I. (£40.)—BENNET & MARTYN, Blo' Norton Hall, East Harling, Norfolk, for **Nimrod**, bay gelding, foaled 1886, breeder unknown.
- 24 II. (£20.)—WM. BROWN, Sunley Court, Kirby Moorside, for **Binglet**, chestnut gelding, foaled 1886, bred by J. Smith, South Holme, Slingsby; s. Conductor, d. by President Junior.
- 26 III. (£10.)—P. S. DANBY, Church Farm, Offchurch, Leamington, for **Gambler**, bay gelding, foaled 1886, breeder unknown; s. Blue Blood.
- 29 B. N. & H. C.—MAJOR LANGLANDS, Biddenham, Bedford, for **Hildegarde**.  
H. C.—JOHN HADLAND for No. 27, **Royalist**; JOHN LETT for No. 30. **Hilarity**.

**Class 3.—Hunter Mares or Geldings, foaled in 1885 or 1886.<sup>1</sup>**  
[27 entries, 10 absent.]

LIGHT WEIGHTS UP TO 12 STONE.

- 48 I. (£30.)—J. F. LAYCOCK, Wiseton, Bawtry, Notts, for **Marquis**, bay gelding, foaled 1885, bred by The Marquis of Waterford, s. Zingaree, d. Cigarette.
- 57 II. (£10.)—J. H. STOKES, Gt. Bowden Ho., Market Harborough, for **Gem**, brown mare, foaled 1886, breeder unknown; s. Lothario, d. by Ascetic.
- 37 III. (£5.)—A. J. BROWN, North Elmsall Hall, Pontefract, for **Nimrod**, brown gelding, foaled 1886, bred by John Hyland, The Castle, Carrick-on-Suir; s. Savoyard, d. Kattie Darling by Artillery.
- 39 B. N. & H. C.—A. J. BROWN, for **Irish Leader**, foaled 1885.

**Class 4.—Hunter Geldings, foaled in 1887.<sup>1</sup>**  
[19 entries, 3 absent.]

- 65 I. (£40.) A. J. BROWN, North Elmsall Hall, Pontefract, for **Carrick**, bay, bred by Mr. Hanley, Cashel; s. Hillingdon, d. by Dr. O'Toole.
- 68 II. (£20.)—THOMAS DARRELL, Spikers Hill, West Ayton, York, for **Wye-dale**, brown, bred by F. Baker, Headon Lodge, Brompton, York; s. Camelot, d. by King Caradoc.
- 69 III. (£10.)—JOHN HADLAND, Norwood, Beverley, Yorks, for **Pilot**, grey, bred by E. Newhouse, Ancliffe Hall, Westmoreland; s. Carthusian.
- 66 B. N. & H. C.—P. S. DANBY, Offchurch, Leamington, for **The Swell**.

**Class 5.—Hunter Mares, foaled in 1887.<sup>1</sup>** [14 entries, 3 absent.]

- 90 I. (£30.)—T. F. & W. J. ROBINSON, Nuthill, Preston, Yorks, for **Gone Away**, bay; s. Tally Ho, d. by Guicowar.
- 94 II. (£15.)—F. B. WILKINSON, Blyth Spital, Rotherham, for **Miss Robson**, brown, breeder unknown; s. Macaulay.
- 91 III. (£5.)—J. H. SANDEBSON, Summer House, Barnsdale, Doncaster, for **Duchess**, bay; s. Knight of the Forest.
- 86 B. N. & H. C.—JOHN LETT, Cleveland Stud Farm, Rillington, for **Clarissa**.

<sup>1</sup> Prizes given by the Doncaster Local Committee.

[Unless otherwise stated, each prize animal named below was "bred by exhibitor."]

**Class 6.—Hunter Geldings, foaled in 1888.**<sup>1</sup> [19 entries, 3 absent.]

- 99 **I.** (£20.)—A. J. BROWN, North Elmsall Hall, Pontefract, for **The General**, chestnut, bred by The O'Grady, Kilballyowen Bruff, Co. Limerick; *s.* Clanronald, *d.* by Old Victor.
- 110 **II.** (£10.)—G. H. SPRAGGON, Nafferton, Stocksfield-on-Tyne, for **Rocket**, chestnut; *s.* Storm Signal, *d.* by Old Victor.
- 108 **III.** (£5.)—W. E. LAWSON, Hazon, Acklington, Northumberland, for **Blaze**, chestnut, bred by H. O. Annett, junr., Widdrington, Northumberland; *s.* Fitzroy.
- 100 **R. N. & H. C.**—A. J. BROWN, for **The Colonel**, grey, *s.* Clanronald.

**Class 7.—Hunter Fillies, foaled in 1888.** [9 entries, 2 absent.]

- 121 **I.** (£15.)—JAMES MARTIN, Wainfleet, for **Dorothy** 319, chestnut; *s.* Fabius, *d.* Yorkshire Lassie 141, *by* The Mallard.
- 118 **II.** (£10.)—ERNEST CHAPLIN, 24 Chester Street, S.W., for **Phoebe** Vol. IV., brown, *s.* Outfit, *d.* Peahen.
- 117 **III.** (£5.)—A. J. BROWN, North Elmsall Hall, Pontefract, for **Wexford** chestnut, breeder unknown; *s.* Hunting Horn, *d.* by Gunboat.
- 123 **R. N. & H. C.** EDWIN WARDLE, Linton Spring, Wetherby, for **Mintdrop**.

**Class 8.—Hunter Geldings, foaled in 1889.**<sup>1</sup> [21 entries, 4 absent.]

- 129 **I.** (£15.)—T. A. CORNTHWAITE, Clawthorpe Hall, Burton, Westmoreland, for **Gamester**, bay, bred by T. Barrow, Ambleside; *s.* Carthusian, *d.* by Cleveland Hero.
- 127 **II.** (£10.)—E. BROMPTON, Rowton, North Skirlaugh, Yorks, for **Marmion**, chestnut; *s.* Lambton, *d.* Lady Williams *by* Haphazard.
- 142 **III.** (£5.)—G. A. WALKER, Danes Hill, Retford, for **The Dane**, brown; *s.* Rainbow, *d.* by Merry Scotland.
- 125 **R. N. & H. C.**—WM. ARKWRIGHT, Sutton Scarsdale, for **Knight Errant**.
- 138 **H. C.**—HUGH PATRICKSON, Kirklington Park, Carlisle, for **Sunlight**.

**Class 9.—Hunter Fillies foaled in 1889.** [14 entries, 1 absent.]

- 156 **I.** (£15.)—WM. MUZEEN, Douthwaite Lodge, Kirby Moorside, for **Modesty**, chestnut; *s.* Spendthrift, *d.* Madam *by* George Osbaldeston.
- 148 **II.** (£10.)—Dr. S. P. BUDD, 8 Gay St, Bath, for **Lady Scot**, grey, bred by T. Keynes, Blandford; *s.* Scot Guard, *d.* Jane 193 *by* Vinegar Hill.
- 158 **III.** (£5.)—RHODES WATERHOUSE, Skellow, Doncaster, chestnut; *s.* Knight Templar, *d.* Queen of Hearts *by* Grandmaster.
- 151 **R. N. & H. C.**—CAPT. JOHN DANBY, W. Hartlepool, for **Lady Normanby**.  
**H. C.**—JOHN BEACH, for No. 145, **Clematis**; G. & J. CODLING, for No. 150, **Bonny Girl**; JAMES MARTIN, for No. 155.  
**Com.**—R. BELLWOOD for No. 146; Rev. C. J. BOWEN for No. 147, **Brunette**; RICH. & ROBT. CHATTERTON for No. 149, **Bay Leaf**; R. ENGLAND for No. 152; G. KENDREW for No. 153, **Lady Brink**; JOHN LETT for No. 154, **Vanity Fair**.

<sup>1</sup> Prizes given by the Doncaster Local Committee.

[Unless otherwise stated, each prize animal named below was "bred by exhibitor."]

**Class 10.**—*Hunter Colts, foaled in 1890.*<sup>1</sup> [22 entries, 5 absent.]

- 180 **I.** (£15.)—F. B. WILKINSON, Blyth Spital, Yorks, for **The Curate**, brown, bred by R. Fawcett, Appleton Wiske; s. Lord Derby, *d. by* Bass Rock.
- 173 **II.** (£10.)—W. C. P. SNOWDEN, Hutton Moor, Thirsk, for **Strathmore**, grey; s. Linnæus, *d. Stella by* Bradgate.
- 168 **III.** (£5.)—LORD MIDDLETON, Birdsall House, York, bay; s. Escamillo, *d. Venus by* Merry Sunshine.
- 165 **B. N.**—G. LANCASTER, Kilton Hall, Brotton, York, for **Butter Scotch**.

**Class 11.**—*Hunter Fillies, foaled in 1890.* [11 entries, 3 absent.]

- 188 **I.** (£15.)—JAMES MARTIN, Wainfleet, for **Mrs. O'Shea**, bay; s. Fabius, *d. Home Rule 353 by* Minstrel.
- 189 **II.** (£10.)—CHARLES MILES, Tatenhill, Burton-on-Tr., for **Lady Connaught**, bay; s. Connaught, *d. Princess 247 by* Pero Gomez.
- 181 **III.** (£5.)—A. J. BROWN, North Elmsall Hall, Pontefract, for **Lady Macaulay**, chestnut; s. Macaulay, *d. by* Lord Athol.
- 187 **R. N. & H. C.**—JOHN LETT, Cleveland Stud Farm, Yorks, for **Queenie**.

## Coach Horses.

**Class 12.**—*Coaching Stallions, foaled in 1886, 1887, or 1888.*<sup>1</sup>  
[19 entries, none absent.]

- 206 **I.** (£20.)—EARL OF LONDESBOROUGH, for **Prince Humbert** 1443 Y.C.S.B., bay, foaled 1888; s. Prince Victor 376, *d. Lady May 186 by* Paulinus 343.
- 195 **II.** (£10.)—GEORGE BURTON, Thorpe Willoughby, Selby, for **Lord Risby** 1402 Y.C.S.B., bay, foaled 1888, bred by H. Donkin, Wyton, Hull; s. Prince of Wales 371, *d. Lady Ida 78 by* Risby 404.
- 210 **III.** (£5.)—G. SCOPY, Beadlam Grange, Nawton, Yorks, **Fortunatus** 962 C.B.S.B., bay, foaled 1888, bred by Rt. Hon. James Lowther, M.P.; s. Luck's All 189, *d. Fortuna 56 by* Fidius Dius 107.
- 203 **B. N.**—R. KITCHING, Hungate, Pickering, Yorks, for **Present Times** 1434.

**Class 13.**—*Coaching Stallions, foaled in 1889.*<sup>1</sup> [28 entries, 5 absent.]

- 220 **I.** (£20.)—W. & C. HARRISON, Barneby Ho., Bossall, Kirkham Abbey, for **Sir James**, bay; s. Lord Chief Justice 1244 Y.C.S.B., *d. Lady Bird II, 73 by* Candidate 64.
- 223 **II.** (£10.)—JOHN KIRBY, Burton Fields, Stamford Bridge, Yorks, for **Kirby's Peacock**, bay, bred by John Gilleard, Crayke, Easingwold; s. Wonderful Lad 536 Y.C.S.B., *d. by* Cromwell.
- 218 **III.** (£5.)—THOMAS CARR, Kirk Smeaton, Pontefract, for **Salisbury**, bay; s. Sultan 667 C.B.S.B., *d. Lille by* Ebor.
- 213 **B. N. & H. C.**—WM. BECKETT, Deighton, Eserick, York, for **Avondale**.  
**H. C.**—GEO. BURTON for No. 217 **Harold**; JOHN LETT for No. 231 **Rillington Symmetry**.  
**Com.**—W. HUTCHINSON for No. 221, **Councillor**; A. E. PEASE, M.P., for No. 233, **Rumpus**.

<sup>1</sup> Prizes given by the Doncaster Local Committee.

[Unless otherwise stated, each prize animal named below was "bred by exhibitor."]

**Class 14.—Coaching Mares and Foals.**<sup>1</sup> [6 entries, 1 absent.]

- 240 **I.** (£20).—T. KELSEY, Hook House, Howden, for **Phyllis** 120 Y.C.S.B., bay, foaled 1885 [foal by Baron Rothsay 981]; s. Lord Beacon 262, d. Jewel 64 by Prince of Wales 371.
- 243 **II.** (£10).—F. J. PETTINGER, Hollins Grove, Easingwold, for **Recherché** 140 Y.C.S.B., bay, foaled 1879 [foal by Wonderful Lad 536], bred by H. Pettinger, Hollins Grove; s. Paragon 337, d. Jess by Cromwell.
- 242 **III.** (£5).—W. PARKIN-MOORE, Whitehall, Mealsgate, Carlisle, for **Lady Rosedale**, 391 C.B.S.B., bay, foaled 1882 [foal by Freedom 833], bred by W. Strickland, Gill Bank, Rosedale, Pickering; s. Emperor 387, d. by Brilliant 42.
- 241 **R. N. & H. C.**—W. PARKIN-MOORE, for **Broxa** 311 C.B.S.B.; s. Emperor.
- 244 **H. C.**—C. COLLESON, Tollesby Farm, Middlesborough, for **Portulaca** 439 C.B.S.B.

**Class 15.—Coaching Geldings, foaled in 1888.**<sup>1</sup> [7 entries, none absent.]

- 249 **I.** (£15).—JOHN KIRBY, Burton Fields, Stamford Bridge, Yorks, for **Elegance**, bay, bred by J. Gamble, Kelfield, York; s. Wonderful Lad 536 Y.C.S.B., d. by Prince of Wales 371.
- 251 **II.** (£10).—F. H. STERICKER, Westgate Ho., Pickering, for **Criterion**, brown, bred by J. Rutter, Long Newton, Darlington; s. King Otto, d. by Luck's All 189 C.B.S.B.
- 250 **III.** (£5).—T. & R. RICHARDSON, Deighton, Escrick, York, for **Grimston**, bay, bred by R. Jackson, Beechwood House, York; s. Wonderful Lad 536 Y.C.S.B.
- 247 **R. N. & H. C.**—C. H. HART, Dunnington Lodge, York, bay.

**Class 16.—Coaching Fillies, foaled in 1888.**<sup>1</sup> [5 entries, none absent.]

- 252 **I.** (£15).—JOHN KIRBY, Burton Fields, Stamford Bridge, Yorks, for **Lady Mary** 265 Y.C.S.B., bay; s. Liverton C.B.S.B., d. Flora 45 Y.C.S.B. by The Earl 474.
- 254 **II.** (£10).—F. J. PETTINGER, Hollins Grove, Easingwold, for **Finetto**, bay; s. Wonderful Lad 536 Y.C.S.B., d. Recherché 140 by Paragon 337.
- 256 **III.** (£5).—W. WHITE, Hutton Grange, Askham Bryan, Yks., for **Hutton Countess**, bay; s. Prince Robert 1151 Y.C.S.B., d. by Palestine 613.
- 255 **R. N. & H. C.**—T. & R. RICHARDSON, Deighton, Escrick, York, for **May**.

**Class 17.—Coaching Geldings, foaled in 1889.** [1 entry, absent.]

**Class 18.—Coaching Fillies, foaled in 1889.**<sup>1</sup> [7 entries, 1 absent.]

- 263 **I.** (£10).—JOHN WHITE, The Grange, Appleton Roebuck, Yorks, **Ainsty Pride**, bay; s. Captain Sykes 1002 Y.C.S.B., d. Jenny 59 by Progress.
- 261 **II.** (£5).—VALENTINE PRODHAM, Allerston, Pickering, for **Grateful**, bay; s. Favourite 581 Y.C.S.B., d. Gratitude 54 by Field Marshal 161.
- 258 **R. N. & H. C.**—E. & R. DUTTON, New Parks, Shipton, for **Georgiana**.

<sup>1</sup> Prizes given by the Doncaster Local Committee.

[Unless otherwise stated, each prize animal named below was "bred by exhibitor."]

## Hackneys.

### Class 19.—Hackney Stallions, foaled before 1889, above 15 hands. [7 entries, 2 absent.]

- 271 I. (£20, & Champion, £15. 15s.<sup>1</sup>)—R. TENNANT, Kirkburn Grange, Driffield, for **Connaught** 1453, chestnut, foaled 1884; s. Denmark 177, d. Fanny 114 by Fireaway 249.
- 265 II. (£10)—F. CHILDERHOUSE, Attleborough, for **M.P.** 1852, chestnut, foaled 1887, bred by R. Wortley, Suffield; s. Candidate 920, d. Franchise 1119 by Robin Hood 677.
- 269 III. (£5.)—ALFRED LEWIS, Heacham, Lynn, for **Tip Top Shot** 1937, chestnut, foaled 1886, bred by W. Dodd, Gayton; s. Great Shot 329, d. Taffy 1832 by Fireaway 265.

### Class 20.—Hackney Stallions, foaled before 1889, above 14 and not exceeding 15 hands. [9 entries, none absent.]

- 278 I. (£20.)—J. H. SMITH, Shipton, Market Weighton, for **Sensation 6th** 3265, chestnut, foaled 1887, bred by G. M. Stephenson, Goodmanham Grange, Market Weighton; s. Confidence 163, d. May Flower 765 by Lord Derby 2nd 417.
- 274 II. (£10.)—H. LIVESEY, Rotherfield, Sussex, for **Evolution** 2058, chestnut, foaled 1886, bred by J. Rutter, Cambridge; s. Reality 665, d. Zazel 3391 by Hue and Cry Shales 379.
- 275 III. (£5.)—SETH LOFTHOUSE, Steeton Grange, Tadcaster, for **Lord Rattler** 2566, brown, foaled 1887; s. Lord Derby 2nd 417, d. Beauty 591 by Sir Charles 768.
- 279 **R. N. & H. C.**—D. R. SOWERBY, Midland Street, Hull, for **Tip Top** 1936.  
**H.C.**—D. HOPKINSON, for No. 272, **High Sheriff** 2nd; W. HURST, for No. 273, **Rokeyby**.

### Class 21.—Hackney Stallions, foaled in 1888.<sup>2</sup> [13 entries, 1 absent.]

- 289 I. (£15.)—H. MOORE, Burn Butts, Cranswick, Hull, for **Caxton** 2398, bay; s. Fireaway 249, d. Poll 3rd 274 by Fireaway 242.
- 285 II. (£10.)—G. M. GALE, Atwick Hall, Hull, for **Sir Alfred** 2nd 2690, bay; s. Wildfire 1224, d. Judy 2nd 684 by Fireaway 249.
- 284 III. (£5.)—R. FORD, Chevet Grange, Wakefield, for **Blaze** 2nd 2376, bay, bred by C. Reader, Sancton, Brough; s. Pioneer 1088, d. Jenny 680 by Fireaway 249.
- 288 **R. N. & H. C.**—A. LEWIS, Heacham, Lynn, for **Confident Shot** 2415.  
**H. C.**—J. W. MOORHOUSE, for No. 290, **King Bruce**; J. RHODES, for No. 291, **Excelsior**.

### Class 22.—Hackney Stallions, foaled in 1889.<sup>2</sup> [16 entries, 2 absent.]

- 294 I. (£15, & R. N. for Champion.<sup>1</sup>)—F. BROUGH, Market Weighton, for **Enthorpe Performer** 2973, bay, bred by C. Mitchell, Enthorpe, Market Weighton; s. Matchless of Londesboro' 1517, d. Peg 3171 by Superior 1410.

<sup>1</sup> Gold Medal given by the Hackney Horse Society for the best Hackney Stallion.

<sup>2</sup> Prizes given by the Doncaster Local Committee.

[Unless otherwise stated, each prize animal named below was "bred by exhibitor."]

- 303 **II. (£10.)**—B. HOW, Manor Farm, Broughton, Hunts, for **Broughton Reality** 2862, bay; s. Reality 665, d. Fanay 2nd 2740 by Baronet.
- 309 **III. (£5.)**—WM. YEOMAN, West Cottingwith, Yorks, for **Romulus** 3249, chestnut; s. Connaught 1453, d. Elegance 2028 by Prince Alfred 1325.
- 307 **R. N. & H. C.**—R. TENNANT, Kirkburn Grange, Yorks, for **Grand Fashion** 2nd.
- 302 **H. C.**—T. HALL, Hanging Grimston, Yorks, for **Garton Duke of Connaught**.  
**Com.**—EXORS. OF LATE T. CROMPTON for No. 296, **Houndales**; WM. FEATHERBY for No. 299, **General Boulanger**; W. P. KIRBY for No. 304, **Cardinal** 4th.

**Class 23.**—*Hackney Brood Mares and Foals, above 15 hands.*  
 [12 entries, 1 absent.]

- 310 **I. (£15.)**—H.R.H. THE PRINCE OF WALES, K.G., for **New York** 1296 chestnut, foaled 1887 [foal by Star of Mepal 1920], bred by Wm. Flanders, Mepal, Ely; s. Reality 665, d. York 370.
- 314 **II. (£10.)**—H. LIVESEY, Rotherfield, Sussex, for **Countess** 2652, black, foaled 1885 [foal by Evolution 2058], bred by W. Askwith, Callis Wold, Yorks; s. Highflyer 1648, d. Callis Lass 610 by Denmark 177.
- 315 **III. (£5.)**—H. LIVESEY, for **Lady Marton** 1204, chestnut, foaled 1885 [foal by Evolution 2058], bred by R. Botham, Marton Grange, Sowerby; s. Denmark 177, d. by Foston Fireaway 288.
- 320 **R. N. & H. C.**—W. WATERHOUSE, Starborough Castle, Kent, for **Brunette**.  
**H. C.**—F. W. BUTTLE for No. 311, **Rosabelle**; S. CAMPION, for No. 312, **Jane**; D. HOPKINSON for No. 313, **Golden Belle**.  
**Com.**—THE EARL OF LONDESBOROUGH for No. 316, **Fireirons**; H. MOORE for No. 318, **Modesty**; STAND STUD CO. for No. 319, **British Queen**; W. WATERHOUSE for No. 321, **Cactus**.

**Class 24.**—*Hackney Brood Mares and Foals, above 14 and not exceeding 15 hands.* [18 entries, 3 absent.]

- 333 **I. (£15, & R. N. for Champion.<sup>1</sup>)**—H. LIVESEY, Rotherfield, Sussex, for **Lily** 219, chestnut, foaled 1882 [foal by Evolution 2058], bred by A. Fewson, Hedon, Hull; s. Lord Derby 2nd 417, d. Polly 279 by Charley 129.
- 324 **II. (£10.)**—F. W. BUTTLE, Thirkleby, Wharram, Yorks, for **Rosalind** 842, bay, foaled 1881 [foal by Rufus 1343], s. Duke of Connaught 595, d. Jessie 682 by Sir Charles 769.
- 332 **III. (£5.)**—H. LIVESEY, for **Nelly** 3rd, 800, chestnut, foaled 1883 [foal by Evolution 2058], bred by W. Rickell, Warter, Pocklington; s. Denmark 177, d. Nelly 257 by St. Giles 687.
- 333 **R. N. & H. C.**—W. WATERHOUSE, Starborough Castle, Kent, for **Caprice**.
- 331 **H. C.**—H. LIVESEY for **Lady Alice**; s. Lord Derby 2nd, 417.
- 336 **Com.**—JOHN ROBINSON, Skerne, Wansford, Hull, for **Lady Jane**.

**Class 25.**—*Hackney Mares or Geldings, above 14 hands, up to 15 stone, foaled 1885, 1886 or 1887.<sup>2</sup>*  
 [11 entries, 2 absent.]

- 346 **I. (£20.)**—WM. POPE, Downham Market, for **Nelly** 2349, bay mare, foaled 1885, bred by J. Bealby, Wisbech; s. Confidence 158, d. Kitty by Shales.
- 349 **II. (£10.)**—T. ROBERTS, 41, Ranelagh St., Liverpool, for **Statesman**, chestnut gelding, foaled 1886, bred by Mr. Staveley, N. Dalton, Hull; s. Confidence.

<sup>1</sup> Gold Medal given by the Hackney Horse Society for the best Hackney Mare.

<sup>2</sup> Prizes given by the Doncaster Local Committee.

[Unless otherwise stated, each prize animal named below was "bred by exhibitor."]

- 344 **III.** (£5).—**JOHN LAYNE**, 5 Lea Road, Gainsborough; for **Lady Ethel**, brown mare, foaled 1886, bred by J. Clark, Holme-on-Spalding Moor; s. Performer Junior 1082, *d.* Poll No. 737 Inspected F. S. *by* Fireaway 249.
- 342 **R. N. & H. C.**—**MRS. ARTHUR FEWSON**, Hedon, Hull; for **Sir Robert**.
- 345 **H. C.**—**H. LIVESEY** for **Hedon**, bay gelding.

**Class 26.**—*Hackney Mares or Geldings, above 14 hands, up to 12 stone, foaled in 1885, 1886, or 1887.*<sup>1</sup> [19 entries, 1 absent.]

- 368 **I.** (£20).—**R. WRIGHT**, 74 Regent Road, Salford; for **Silver King**, grey gelding, foaled 1886, breeder unknown; s. Confidence 158.
- 366 **II.** (£10).—**T. ROBERTS**, 41 Ranelagh St., Liverpool; for **Graceful**, bay mare, foaled 1886, breeder unknown; s. Merryheart, *d.* *by* Denmark.
- 358 **III.** (£5).—**ARTHUR FEWSON**, Hedon, Hull; for **The Swell**, chestnut gelding, foaled 1886; s. Confidence 163, *d.* Lily 219 *by* Lord Derby 2nd.
- 351 **R. N. & H. C.**—**JOHN BENTLEY**, Skerne Road, Driffield, for **Queen Esther**.
- 356 **H. C.**—**SIR HUMPHREY F. DE TRAFFORD, BART.**, for **Lady Landseer**.
- 360 **Com.**—**MRS. R. KIBBY**, Elmswell Hall, Driffield, for **Duke of Portland**.

**Class 27.**—*Hackney Fillies, foaled in 1888.*<sup>1</sup> [9 entries, 1 absent.]

- 374 **I.** (£15, & Champion, £15 15s.<sup>2</sup>)—**H. LIVESEY**, Rotherfield, Sussex, for **Lady Keyingham** 2925, chestnut; s. Danegelt 174, *d.* Dorothy 2016 *by* Lord Derby 2nd 417.
- 375 **II.** (£10).—**THE EARL OF LONDESBOROUGH**, for **Vanity** 2490, bay; s. Candidate 920, *d.* Coquette 1059 *by* Pluto 590.
- 376 **III.** (£5).—**THE EARL OF LONDESBOROUGH**, for **Odd Stockings** 3152, chestnut, bred by W. H. Smith, High Field, Bubwith, Yorks; s. Prince Alfred 1325, *d.* *by* Highflyer 1648.
- 371 **R. N. & H. C.**—**C. E. COOKE**, Litcham, Swaffham, for **Florence** 2069.
- 370 **H. C.**—**H.R.H. THE PRINCE OF WALES, K.G.**, for **Star of Denmark** 3286.

**Class 28.**—*Hackney Fillies foaled in 1889.*<sup>1</sup> [13 entries, 1 absent.]

- 391 **I.** (£15).—**J. W. TEMPLE**, Leyswood, Groombridge, Kent, for **Lady Dereham** 2891, chestnut, bred by H. Livesey; s. Ritualist 1542, *d.* Dorothy 2016 *by* Lord Derby 2nd 417.
- 390 **II.** (£10).—**WM. SETH SMITH**, Albert St., Derby, for **Sweetest** 3307, chestnut; s. Connaught 1453, *d.* Columbine 1057 *by* Dorrington 184.
- 380 **III.** (£5).—**A. W. HICKLING**, 34 Regent St., Nottingham, for **Fair Confidence**, bay, bred by L. Rodwell, Bagthorpe Hall, Norfolk; s. Confidence 158, *d.* Jessie 273 Inspected F. S. *by* Model 1054.
- 383 **R. N. & H. C.**—**H. LIVESEY**, for **Lady Mayfield**, brown; s. Confidence 158.
- 382 **H. C.**—**H. LIVESEY**, for **Linda**; s. Connaught 1453.

## Ponies.

**Class 29.**—*Pony Stallions, not above 14 hands.*

[5 entries, none absent.]

- 393 **I.** (£15).—**C. E. COOKE**, Litcham, Swaffham, for **Cassius** 2397, chestnut, foaled 1888; s. Cadet 1251, *d.* Belle 5th 406 *by* Confidence 158.

<sup>1</sup> Prizes given by the Doncaster Local Committee.

<sup>2</sup> Gold Medal given by the Hackney Horse Society for the best Hackney Mare.

[Unless otherwise stated, each prize animal named below was "bred by exhibitor."]

- 394 **II.** (£10.)—G. H. K. FRANCIS, Mattishall, Dereham, for **Lord Barsham**, bay, foaled 1887, bred by C. S. Leeds, North Barsham, Walsingham; *s.* Confidence, *d.* Ada No. 416, Inspected F.S.
- 392 **R. N. & H. C.**—BUTCHER & THOMAS, Bedminster, Bristol, for **Eclipse**.

**Class 30.**—*Pony Brood Mares and Foals not above 14 hands.*  
[6 entries, none absent.]

- 402 **I.** (£15.)—C. W. WILSON, Rigmaden Park, Kirkby Lonsdale, for **Snorer** 2456, bay, foaled 1879 [foal *by* Little Wonder 2nd 1610]; *s.* Sir George 778, *d.* The Pet.
- 400 **II.** (£10.)—J. S. JACKSON, Wetheral, Carlisle, for **Rhoda**, grey, foaled 1877 [foal *by* Little Wonder 2nd 1610]; *s.* Judge, *d.* Rhoda.
- 397 **III.** (£5.)—D. COOPER, Bainesse, Catterick, for **Lady Bute** 378, black, foaled 1875 [foal *by* Danegelt 174], bred by Mr. Ward, Narbeth; *s.* Christmas Carol, *d.* Welsh mountain pony.
- 401 **R. N. & H. C.**—TOM MITCHELL, The Park, Eccleshill, Yorks, for **Olivette**.

**Class 31.**—*Pony Mares or Geldings above 13 hands and not above 14 hands.*<sup>1</sup> [6 entries, 1 absent.]

- 408 **I.** (£10.)—RICHARD WRIGHT, 74 Regent Road, Salford, bay mare, foaled 1886, breeder unknown.
- 407 **II.** (£5.)—C. W. WILSON, Rigmaden Park, Kirkby Lonsdale, for **Madcap** 1238, bay mare, foaled 1887, bred by G. Bowhill, Sutton, Wymondham; *s.* Confidence 158, *d.* pony mare.
- 404 **R. N. & H. C.**—JOHN LAYNE, 5 Lea Road, Gainsborough, for **Baronet**.

**Class 32.**—*Pony Mares or Geldings, not above 13 hands.*<sup>1</sup>  
[11 entries, none absent.]

- 415 **I.** (£10.)—WM. POPE, Downham Market, for **Princess** 750 Inspected F. S., bay mare, foaled 1885, bred by D. Goodman, Little Snoring, Norfolk; *s.* Model.
- 410 **II.** (£5.)—G. E. FRANKLIN, St. Leonard's House, Derby, for **Lady Mona**, brown mare, foaled 1886, breeder unknown.
- 411 **R. N. & H. C.**—J. GOODWILL, North Ings, Terrington, Yorks, for **Gladys**.  
**H. C.**—MASTER HECTOR MOTTET, for No. 414, **Bob**; STAND STUD CO., for No. 419, **Rattler**.

## Harness Horses and Ponies.

(To be shown in Harness with suitable vehicles.)

**Class 33.**—*Harness Mares or Geldings, of any age, above 14 hands.*<sup>1</sup>  
[9 entries, 2 absent.]

- 420 **I.** (£15.)—T. BENTLEY, Driffield, for **Performer**, chestnut gelding, foaled 1887, bred by R. Kirby, Elmswell, Driffield; *s.* Skipsea Performer 1568.
- 425 **II.** (£10.)—C. FOWLER, Lincoln, for **Flower of Denmark** 1115, roan mare, foaled 1885; *s.* Denmark 177, *d.* Bonnie Belle 1028 *by* Fireaway 252.

<sup>1</sup> Prizes given by the Doncaster Local Committee.



[Unless otherwise stated, each prize animal named below was "bred by exhibitor."]

- 426 **III.** (£5.)—A. H. MILTON, Castleton House, Clifton, for **Duchess of Portland**, brown mare, foaled 1883, bred by Mrs. Kirby, Elmswell Hall, Driffield; *s.* Fireaway 249.
- 422 **B. N. & H. C.**—F. W. BUTTLE, Thirkleby, Wharram, Yorks, for **Marmion**.

**Class 34.**—*Harness Mares or Geldings, not above 14 hands.*<sup>1</sup>  
[9 entries, 2 absent.]

- 435 **I.** (£15.)—Wm. POPE, Downham Market, for **Magpie** 228, black and white mare, foaled 1878, bred by Mr. Cooke, Litcham, Swaffham; *s.* Confidence 1743, *d.* Spot 237 *by* Premier.
- 430 **II.** (£10.)—H. DAPLYN, Hindringham, Walsingham, for **Norfolk Model** 2358, bay mare, foaled 1887, bred by J. Mann, Hempton, Fakenham; *s.* Model 1054, *d.* Mrs. Mann 3114 *by* Little Wonder 409.
- 437 **III.** (£5.)—G. WARREN, Strawberry Fields, Woolton, Liverpool, for **My Queen**, bay mare, foaled 1884, breeder unknown.
- 432 **B. N. & H. C.**—A. H. MILTON, Castleton House, Clifton, for **Lady Elsie**.

## Shires.

**Class 35.**—*Shire Stallions, foaled in 1888.* [26 entries, 6 absent.]

- 457 **I.** (£20, & **B. N.** for **Champion**.<sup>2</sup>)—P. A. MUNTZ, M.P., Dunsmore, Rugby, for **Forest King** 9395, brown, bred by Col. H. Platt, Gorddingog, Llanfairfechan; *s.* Carbon, 3523, *d.* Gladys *by* What's Wanted 2332.
- 440 **II.** (£10.)—CANNOCK AGRICULTURAL CO., LTD., for **Hartington II.** 9523, brown, bred by J. L. Luddington, Littleport, Ely; *s.* Hatherton 4443, *d.* Welcome Blackbird *by* Matchless 1538.
- 443 **III.** (£5.)—A. CRAWFORD, West Leake, Loughborough, for **Leake Pioneer**. 9776, bay, bred by E. Bryan, Newton, Alfreton; *s.* Duke of Hitchin 3063, *d.* Brisk *by* Champion 437.
- 450 **B. N. & H. C.**—H. W. GRIMES, Scarcliffe Grange, for **Scarcliffe Bronze**.
- 452 **H. C.**—JOHN HARRISON, for **Everton Benefactor** (late Champion).  
**Com.**—LORD BELPER, for No. 439, **Leake Donovan**; J. FORSHAW, for No. 445, **Aluminium**.

**Class 36.**—*Shire Stallions, foaled in 1889.* [34 entries, 5 absent.]

- 494 **I.** (£20, & **Champion**, £15 15s.<sup>2</sup>)—JOHN ROWELL, Bury, Huntingdon, for **Bury Victor Chief** 11105, black; *s.* Prince Victor 5287, *d.* Bury Daisy *by* Chatteris Le Bon 3023.
- 478 **II.** (£10.)—C. E. GALBRAITH, Ayton Castle, N.B., for **Twilight**, brown, bred by R. J. Heanes, Sutton St. James, Wisbech; *s.* King John 4502, *d.* Flower *by* Kilham's Thumper 7479.
- 485 **III.** (£5.)—LORD MIDDLETON, Birdsall House, York, for **Silver Prince II.** 12283, grey; *s.* Northwood 4593, *d.* Silver Queen *by* Thumper 2136.
- 487 **B. N. & H. C.**—P. A. MUNTZ, M.P., for **Dunsmore Barrier**.  
**H. C.**—J. FORSHAW, for No. 476, **Layton Echo**; G. HARRISON for No. 483, **Everton Laddie**.  
**Com.**—J. P. CROSS, for No. 472, **Catthorpe Sandow**; SIR Wm. EDEN, Bart., for No. 475, **Challenger**.

<sup>1</sup> Prizes given by the Doncaster Local Committee.

<sup>2</sup> Gold Medal given by the Shire Horse Society for the best Shire Stallion.

[Unless otherwise stated, each prize animal named below was "bred by exhibitor."]

**Class 37.—Shire Stallions, foaled in 1890.** [31 entries, 8 absent.]

- 511 I. (£20).—WALTER GILBEY, Elsenham Hall, Essex, for **Saxon Conqueror**, bay; s. Norman Conqueror 7940, d. Tinsel by King of Trent 3175.
- 524 II. (£10).—THOMAS SHAW, Winmarleigh, Garstang, bay, bred by J. Bond, Mere Brow, Tarleton, Preston; s. Akbar 4821, d. by John o' Gaunt 2601.
- 502 III. (£5).—PETER BLUNDELL, Ream Hills, Weeton, Kirkham, for **Prince Harold**,<sup>1</sup> black, bred by T. Charnock, Houghton Tower Farm, Hale, Liverpool; s. Harold 3703, d. Hale Lofty by Cromwell 2415.
- 513 R. N. & H. C.—T. LOWNDES & SON, Eastern Hall, for **Eastern Harold**.  
H. C.—A. C. DUNCOMBE, for No. 507, **Calwich Marksman**; F. W. PARK, for No. 517, **Headon Guardsman**.  
Com.—WM. ARKWRIGHT, for No. 500, **Scarsdale Deceiver**; A. C. DUNCOMBE, for No. 506, **Calwich Masterman**; P. A. MUNTZ, M.P., for No. 515, **Dunsmore Bismark**.

**Class 38.—Shire Mares and Foals.** [9 entries, 3 absent.]

- 530 I. (£20, & Champion, £15 15s.<sup>2</sup>).—FRED CRISP, White House, New Southgate, N., for **Starlight**, black, foaled 1882 [foal by Knight Errant 6805], bred by T. Williamson, Out Rawcliffe, Garstang; s. Sir Colin 2022; d. Williamson's Mettle by Honest Tom 1105.
- 534 II. (£10).—P. ALBERT MUNTZ, M.P., Dunsmore, Rugby, for **Dunsmore Fashion**, roan, foaled 1887 [foal by Ringleader II. 8099], bred by R. Capes, Meathop Farm, Grange-over-Sands; s. Vulcan 4145, d. Kit by Champion.
- 536 III. (£5).—THE DUKE OF PORTLAND, Welbeck Abbey, Notts, for **Scarcliffe Kathleen**, brown, foaled 1885 [foal by Bar None 2388], bred by W. H. Dicken, Mickleover, Derby; s. Lincolnshire Boy 3188, d. Smiler by Honest Prince 1058.
- 532 R. N.—M. DURHAM'S TRUSTEES, Thorne, Doncaster, for **Princess Ida**.

**Class 39.—Shire Fillies, foaled in 1888.** [17 entries, 2 absent.]

- 541 I. (£15, & R. N. for Champion.<sup>2</sup>).—J. P. CROSS, Catthorpe Towers, Rugby, for **Mavourneen**, bay; s. Harold 3703, d. Kate by Active 51.
- 540 II. (£10).—JOHN CONCHAR, Wylde Green, Birmingham, for **Flower of May**, chestnut, bred by R. N. Sutton-Nelthorpe, Scawby Hall, Brigg; s. Chance Shot 4960, d. Flower Girl by What's Wanted 2332.
- 554 III. (£5).—LORD WINMARLEIGH, Winmarleigh, Garstang, for **Wagtail**, bay; s. Vulcan 4145, d. Bessie by Luck 1424.
- 545 R. N. & H. C.—WALTER GILBEY, Elsenham Hall, Essex, for **Harebell**.  
H. C.—WM. ARKWRIGHT, for No. 538, **Scarsdale Auburn**, and No. 539, **Scarsdale Creole**; GEORGE HARRISON, for No. 547, **Everton Charmer**; J. WAINWRIGHT, for No. 552, **Bowden Empress**.  
Com.—SIR HUMPHREY DE TRAFFORD, Bart., for No. 542, **Tamarind**; J. FLINN, for No. 543, **Dunsmore Berry**; C. E. GALBRAITH, for No. 544, **Gitana**; A. GRANDAGE, for No. 546, **Yorkshire Lassie**; JOHN NIX, for No. 549, **Duchess**; JOHN PARNELL, for No. 550, **Royal Poppy**; LORD WINMARLEIGH, for 553, **Wellborn**.

**Class 40.—Shire Fillies, foaled in 1889.** [23 entries, 8 absent.]

- 556 I. (£15).—H. & R. AINSCOUGH, Burscough, Ormskirk, for **Aurora**, bay, bred by J. Lofthouse, Chipping, Preston; s. Maharajah 3207, d. Venus by Nonpareil 1619.

<sup>1</sup> A protest against any award being made to this horse is under consideration.

<sup>2</sup> Gold Medal given by the Shire Horse Society for the best Shire Mare or Filly.

[Unless otherwise stated, each prize animal named below was "bred by exhibitor."]

- 559 **II.** (£10.)—**JAMES BLYTH**, Wood House, Stansted, for **Blythwood Bountiful**, bay, bred by John Blunt, Breedon-on-the-Hill, Ashby-de-la-Zouch; *s.* Harold 3703, *d.* Bonny Lady by Royal Albert 1885.
- 570 **III.** (£5.)—**LORD HINDLIP**, Hindlip, Worcester, for **Hindlip Lady**, bay, bred by the late Hon. E. Coke; *s.* All Here 4829, *d.* Comfy by Charter.
- 563 **B. N. & H. C.**—**J. FORSHAW**, Carlton-on-Trent, Newark, for **Claribelle**. **H. C.**—**H. & R. AINSCOUGH**, for No. 555, **Alfresco**; **WM. ARKWRIGHT**, for No. 558, **Scarsdale Sparkle**; **SIR WM. EDEN**, Bart., for No. 562, **Flasher**. **Com.**—**WM. HURST**, for No. 571, **Lady Lincoln**; **JOHN PARNELL**, for No. 573, **Lady Cresswell**.

**Class 41.**—*Shire Fillies, foaled in 1890.* [24 entries, 6 absent.]

- 596 **I.** (£15.)—**T. H. MILLER**, Singleton Park, Poulton-le-Fylde, for **Marina** bay; *s.* Mohammed 6173 or Moloch 6174, *d.* Mermaid by Lincoln 1350.
- 598 **II.** (£10.)—**JOHN ROWELL**, Manor Farm, Bury, Huntingdon, for **Bury Countess**, bay, bred by Trustees of the late Earl of Dysart; *s.* Warrior 2689, *d.* Witham Violet by King Charles 3775.
- 594 **III.** (£5.)—**W. B. LONGTON**, Cronton Hall, Prescott, for **Cronton Ladylike**, brown, bred by C. J. Bowers, Uttoxeter; *s.* Premier, 2646, *d.* by Drayman.
- 590 **B. N. & H. C.**—**T. HARDY**, Mere Hall Farm, Knutsford, for **Mere Duchess**. **H. C.**—**H. W. GRIMES**, for No. 589, **Scarcliffe Amazon**; **J. HOGGARTH**, for No. 592. **Com.**—**WM. ARKWRIGHT**, for No. 578, **Scarsdale Amazon**; **M. DURHAM'S TRUSTEES**, for No. 583, **Princess Maud**; **MYLES WOODBURNE**, for No. 601, **Thurston Mary**.

## Clydesdales.

**Class 42.**—*Clydesdale Stallions, foaled in 1888.*

[3 entries, none absent.]

- 604 **I.** (£20.)—**W. MONTGOMERY**, Banks, Kirkcudbright, for **Breastplate** 8489, brown, bred by Wm. McDowall, Dalchest, Kirkholm, N.B.; *s.* Aim Well 4216, *d.* Nell of Dalchest 9918 by Blue Ribbon 1961.
- 602 **II.** (£10.)—**WM. GRAHAM**, Eden Grove, Penrith, for **Maccash** 7997, bay, bred by R. & T. Sproat, Culdoch, Kirkcudbright; *s.* Macgregor 1487, *d.* Bowena 6770 by Druid 1120.

**Class 43.**—*Clydesdale Stallions, foaled in 1889.* [13 entries, 3 absent.]

- 614 **I.** (£20, & Champion, £25.) **WM. RENWICK**, Meadowfield, Corstorphine, N.B., for **Prince Alexander** 8899, bay, bred by A. Black, Craigencross, Stony-kirk, N.B.; *s.* Prince of Wales 673, *d.* Jeanie Black 8100 by Darnley 222.
- 612 **II.** (£10, & **R. N.** for Champion.)—**A. MONTGOMERY**, Nether Hall, Castle Douglas, N.B., for **Prince Patrick** 8933, brown, bred by W. H. Ralston, Culmore, Stranraer; *s.* Prince of Wales 673, *d.* Elia 7741 by M'Camon.
- 613 **III.** (£5.)—**A. MONTGOMERY**, for **Macquhae** 8827, bay, bred by S. Campbell's Trustees, Rattrra, Bogue; *s.* Macgregor 1487, *d.* Nannie of Rattrra 1075 by Superior 837.
- 606 **B. N. & H. C.**—**LORDS A. & L. CECIL**, Orchardmains, for **Crown of Royalty**.

<sup>1</sup> Given by the Clydesdale Horse Society for the best Clydesdale Stallion.

[Unless otherwise stated, each prize animal named below was "bred by exhibitor."]

**Class 44.**—*Clydesdale Stallions, foaled in 1890.* [8 entries, 2 absent.]

- 624 **I.** (£20.)—A. MONTGOMERY, Nether Hall, Castle Douglas, N.B., for **Ross Macgregor**, bay, bred by J. Finlay, Ross, Kirkcudbright; *s.* Macgregor 1487, *d.* Jess 1236 *by* Prince of Kelvin 656.
- 621 **II.** (£10.)—SIR JOHN A. HAY, Bart., Kingsmeadows, Peebles, N.B., bay; *s.* Prince of Albion 6178, *d.* Lady Gallant *by* Top Gallant 1850.
- 622 **III.** (£5.)—JOHN KERR, Red Hall, Wigton, for **Royal Conqueror**, brown; *s.* Royal George 8205, *d.* Kate Macgregor 6325 *by* Macgregor 1487.
- 619 **R. N. & H. C.**—GALBRAITH BROS., Croy Cunningham, New Killearn, N.B.
- 623 **H. C.**—THE MARQUIS OF LONDONDERRY, K.G.

**Class 45.**—*Clydesdale Mares and Foals.* [7 entries, none absent.]

- 628 **I.** (£20.)—WM. GRAHAM, Eden Grove, Penrith, for **Lizzie of Inchparks** 9698, bay, foaled 1886 [foal *by* Lothian King 6985], bred by John Parker, Inchparks, Stranraer; *s.* Belted Knight 1395, *d.* Inchpark Nell 5688 *by* Lord Lyon 489.
- 626 **II.** (£10.)—EARL OF CAWDOR, Stackpole Court, Pembroke, for **Bell**, brown, foaled 1887 [foal *by* Flashwood Again 7716], bred by A. McDowal, Harlaw, Balerno, N.B.; *s.* Obedience 2313, *d.* Maggie of Harlaw 5574 *by* Abbey Prince 2.
- 631 **III.** (£5.)—LORD POLWARTH, Mertoun House, St. Boswells, N.B., for **Comfort**, brown, foaled 1887 [foal *by* Goldenberry 2828], bred by A. McDowal, High Milton, Port William, N.B.; *s.* Lord Dunglass 2961 or Westfield Chief 6390, *d.* Maggie II. of Milton 2636 *by* Lord Derby 485.
- 627 **R. N. & H. C.**—GALBRAITH BROS., for **Topsman's Princess** 8403.
- 629 **H.C.**—THE MARQUIS OF LONDONDERRY, K.G. for **Rhoda**.
- 632 **Com.**—R. S. SCOTT, for **Scottish Pearl**.

**Class 46.**—*Clydesdale Fillies, foaled in 1888.*

[9 entries, none absent.]

- 640 **I.** (£15, & **Champion**, £25.<sup>1</sup>)—R. S. SCOTT, Craigievar, Skelmorlie, N.B., for **Scottish Snowdrop**, brown, bred by John M'Caig, Challoch, Stranraer; *s.* Prince of Wales 673, *d.* Duchess II. of Challoch 7500 *by* Darnley 222.
- 633 **II.** (£10.)—THE EARL OF CAWDOR, Stackpole Court, Pembroke, for **Decreto**, brown, bred by J. Drew, Doonhill, Newton Stewart, N.B.; *s.* Flashwood 3604, *d.* Diana 7179 *by* Macgregor 1487.
- 641 **III.** (£5.) PATRICK STIRLING OF KIPPENDAVIE, Kippenross House, Dunblane, for **Brenda of Kippendavie**, brown; *s.* Knight Errant 4483, *d.* Nelly 7861 *by* Sir Gordon 4018.
- 639 **R. N. & H. C.**—LORD POLWARTH, for **Connie Nairn**.
- 634 **Com.**—LORDS A. & L. CECIL for **Chrystabel**.

**Class 47.**—*Clydesdale Fillies, foaled in 1889.* [7 entries, 1 absent.]

- 646 **I.** (£15, & **R. N. for Champion**.<sup>1</sup>)—WM. MONTGOMERY, Banks, Kirkcudbright, for **Crosby Rose**, bay, bred by R. B. Brockbank, Crosby, Maryport; *s.* Sirdar 4714, *d.* Jewel 8136 *by* Challenger 1088.
- 647 **II.** (£10.)—LORD POLWARTH, Mertoun House, St. Boswells, for **Maggie IV.**, brown, bred by A. & A. Mitchell, Alloa; *s.* Sirdar 4714, *d.* Maggie III. 8976 *by* Corsewall 1420.

<sup>1</sup> Given by the Clydesdale Horse Society for the best Clydesdale Mare or Filly.

[Unless otherwise stated, each prize animal named below was "bred by exhibitor."]

- 643 **III.** (£5).—LORDS A. & L. CECIL, Orchardmains, Tunbridge, for **Carissima**, bay; s. Claymore 3522, d. Darling 1093 by Topsman 886.
- 642 **R. N. & H. C.**—LORDS A. & L. CECIL, for **Carillon**; s. Claymore 3522.

**Class 48.**—*Clydesdale Fillies, foaled in 1890.* [10 entries, 3 absent.]

- 652 **I.** (£15).—EARL OF GALLOWAY, K.T., Garliestown, Wigtownshire, for **Lillie Langtry**, brown; s. Flashwood 3604, d. Maritana 8406 by Premier Lyon.
- 656 **II.** (£10).—A. MITCHELL, Barcheskie, Kirkcudbright, for **Muriel**, brown, bred by Wm. Watson, Ochterlony Mains, Guthrie, Forfar; s. Prince Lawrence, d. Pet 6852 by Stanley-muir 1536.
- 654 **III.** (£5).—WM. GRAHAM, Eden Grove, Penrith, for **Crosby Jewel**, bay, bred by R. B. Brockbank, Crosby, Maryport; s. The Claimant 7318, d. Jewel of Parkhead 8136 by Challenger 1088.
- 657 **R. N. & H. C.**—A. MONTGOMERY, Castle Douglas, N.B., for **May Queen**.
- 650 **H. C.**—LORDS A. & L. CECIL, for **Queen Bess**; s. Lothian King 6985.

## Suffolks.

**Class 49.**—*Suffolk Stallions, foaled in 1888.* [8 entries, 1 absent.]

- 664 **I.** (£20).—JAMES TOLLER, Blaxhall, Wickham Market, for **Rainbow** 1922 chestnut; s. Toller's Verger 1550, d. Re-echo 1581 by Prince Imperial 1239.
- 665 **II.** (£10).—HORACE WOLTON, Newbourn Hall, Woodbridge, for **Trumpeter** 1915, chestnut, bred by Mr. Juby, Whatfield; s. Leiston 1415, d. Duke 2536 by May Duke 1256.
- 661 **III.** (£5).—WM. EVERITT, Levington, Ipswich, for **Warrior** 1938, chestnut; s. Everitt's Levington Prince 1771, d. Brag by Rodney 161.
- 660 **R. N. & Com.**—WM. BYFORD, for **Alderman**; 659 **Com.** for **Surprise**.

**Class 50.**—*Suffolk Stallions, foaled in 1889.* [12 entries, 4 absent.]

- 673 **I.** (£20).—I. PRATT & SON, Foxboro Hall Farm, Melton, Woodbridge, for **Eclipse** 2010, chestnut, bred by E. Capon, Aldeby; s. Cupbearer III. 566, d. Grace 335 by Viceroy 570.
- 669 **II.** (£10).—DUKE OF HAMILTON & BRANDON, K.T., Easton Park, Wickham Market, for **Wedgewood 2nd** 2045, chestnut, bred by B. A. Posford, Falkenham, Ipswich; s. Smith's Wedgewood 1749, d. Diamond by Wolton's Royalty 1339.
- 671 **III.** (£5).—W. H. HEWITT, West Hill, Copdock, Ipswich, for **Windsor Chieftain** 2025, chestnut, bred by R. Wrinch, Harkstead, Ipswich; s. Chieftain 1354, d. Juno 1500 by Cupbearer III. 566.
- 677 **R. N.**—ALFRED J. SMITH, Rendlesham, Woodbridge, for **Democrat** 2044.

**Class 51.**—*Suffolk Mares and Foals.* [6 entries, none absent.]

- 680 **I.** (£20).—THE DUKE OF HAMILTON & BRANDON, K.T., Easton Park, Wickham Market, for **Queen of Diamonds** 1859, chestnut, foaled 1883 [foal by Wanderer 1463], bred by T. Hayward, Ringshall; s. Vanguard 1327, d. by Suffolk Emperor 618.
- 681 **II.** (£10).—W. H. HEWITT, of West Hill, Copdock, Ipswich, for **Juno** 1500, chestnut, foaled 1881 [foal by Walton's Emperor 1611], bred by G. & A. Rope, Leiston; s. Cupbearer III. 566, d. Maggy.

[Unless otherwise stated, each prize animal named below was "bred by exhibitor."]

683 **III.** (£5.)—HORACE WOLTON, Newbourn Hall, Woodbridge, for **Pearl** 1621, chestnut, foaled 1881 [foal *by* **Pride's Pilgrim** 1707]; s. **Wolton's Prince Royal** 1338, d. **Ruby** of Newbourn 1053 *by* **Monarch** 1348.

682 **R. N. & Com.**—J. HUME-WEBSTER, of Marden Deer Park, for **Mettle**.

**Class 52.**—*Suffolk Fillies, foaled in 1888.* [6 entries, 3 absent.]

686 **I.** (£15.)—DUKE OF HAMILTON & BRANDON, K.T., Easton Park, Wickham Market, for **Morella** 2375, chestnut, bred by C. A. Kersey, Monewdon; s. **Cupbearer III.** 566, d. **Lucy** 1175 *by* **Hurren's Bismark** 729.

690 **II.** (£10.)—JAMES TOLLER, of Blaxhall, Wickham Market, for **Violet** 2453, chestnut; s. **Wantisden Duke** 534, d. **Virtue** 1597 *by* **Cupbearer III.** 566.

688 **R. N.**—W. H. HEWITT, West Hill, Copdock, Ipswich, for **Nettle** 2347.

**Class 53.**—*Suffolk Fillies, foaled in 1889.* [9 entries, 3 absent.]

691 **I.** (£15.)—DUKE OF HAMILTON & BRANDON, K.T., Easton Park, Wickham Market, for **Queen of Trumps** 2702, chestnut, bred by C. Austin, Brandeston Hall, Wickham Market; s. **Cupbearer III.** 566, d. **Queen of Diamonds** 1859 *by* **Vanguard** 1327.

696 **II.** (£10.)—W. E. S. & P. H. WILSON, Hadleigh, for **Darling** 2699, chestnut; s. **Chieftain** 1354, d. **Duke** 2260 *by* **Captain** 1833.

693 **III.** (£5.)—J. HUME-WEBSTER, Marden Deer Park, Surrey, for **The Miller's Daughter** 2608, chestnut, bred by M. Biddell, Playford; s. **Sultan** 1727, d. **Miller** 1183 *by* **Colonel Snap** 1432.

698 **R. N. & Com.**—H. WOLTON, Newbourn Hall, Woodbridge, for **Matchett**.

## Agricultural Horses.

**Class 54.**—*Agricultural Geldings of any breed, foaled in 1887 or 1888.*<sup>1</sup> [11 entries, none absent.]

708 **I.** (£15.) LORD WANTAGE, K.C.B., V.C., Lockinge, Wantage, brown, foaled 1887, breeder unknown.

704 **II.** (£10.)—VISCOUNT GALWAY, Serlby Hall, Bawtry, for **Golden Star**, chestnut, foaled 1887; s. **Hydrometer**.

700 **III.** (£5.)—J. T. BROWN, Althorp, Doncaster, for **Althorp Samson**, bay, foaled 1888, bred by E. Ellis, Bentley, Yorks; s. **Samson**.

707 **R. N. & H. C.**—ARTHUR PEASE, Hummersknott, Darlington, for **Briton**.

701 **H. C.**—T. CROYSDALE, Whitley Bridge, Pontefract, foaled 1888.

**Com.**—S. FAIRBAIRN for No. 703; R. H. WRIGHTSON for No. 709.

**Class 55.**—*Agricultural Geldings of any breed, foaled in 1889.*<sup>1</sup>  
[3 entries.]

713 **I.** (£15.)—HENRY LAWSON, Skirpenbeck, Stamford Bridge, Yorks, for **Briton**, chestnut, bred by J. D. Lawson, Sutton-on-Forest, Easingwold; s. **Rule Britannia** 5430, d. *by* **Bar None** 2388.

712 **II.** (£10.)—HENRY LAWSON, for **Baron**, chestnut, bred by J. D. Lawson; s. **Bar None** 2388.

711 **R. N.**—WM. HURST, Sandal, Wakefield, for **Prince William**.

<sup>1</sup> Prizes given by the Doncaster Local Committee.

[Unless otherwise stated, each prize animal named below was "bred by exhibitor."]

## CATTLE.

## Shorthorns.

Class 56.—*Shorthorn Bulls calved in 1885, 1886, 1887, or 1888.*

[16 entries, 4 absent.]

- 721 I. (£20.)—EVAN JONES, Manoravon, Llandilo, for **Nugget** 59534, roan, born July 6, 1888; *s.* Bright Cymro 54039, *d.* Golden Hope *by* Golden Treasure 51346.
- 723 II. (£10.)—ROBERT THOMPSON, Inglewood, Penrith, for **Merry Beau** 56180, roan, born Mar. 13, 1887; *s.* Beau Benedict 42769, *d.* Fair Millicent 2nd *by* Brilliant Butterfly 36270.
- 724 III. (£5.)—LORD POLWARTH, Mertoun House, St. Boswells, N.B., for **Commander** 54116, roan, born Apr. 20, 1885; *s.* King Stephen 46559, *d.* Wave of the Ocean *by* Rapid Rhone 35205.
- 725 R. N.—LORD POLWARTH, for **Gunboat**, red and white, born Feb. 16, 1888. H. C.—A. M. GORDON, for No. 719, **Star of Morning**; THE DUKE OF PORTLAND for No. 727, **King George**.  
Com.—MRS. ATKINSON for No. 714, **Baron Ingram**; TRUSTEES OF SIR R. G. MUSGRAVE, Bart. for No. 723, **Daybreak**.

Class 57.—*Shorthorn Bulls calved in 1889.* [24 entries, 3 absent.]

- 745 I. (£20 & Champion, £25.<sup>1</sup>)—LORD POLWARTH, Mertoun House, St. Boswells, N.B., for **Windsor Royal**, roan, born May 19; *s.* Royal Riby 52056, *d.* Wave of the Ocean (vol. xxxvi. p. 599) *by* Rapid Rhone 35205.
- 752 II. (£10.)—H. WILLIAMS, Moor Park, Harrogate, for **Major** 59419, red & white, born Jan. 23, bred by H.M. the Queen, Windsor; *s.* Field Marshal 47870, *d.* Molly Lind 2nd *by* Goldfinder 47967.
- 740 III. (£5.)—R. & G. HARRISON, Underpark, Lealholm, Grosmont, Yorkshire, for **Duncan Grey**, roan, born Aug. 8, bred by Wm. Scorsby, Knapton, Rillington; *s.* Merryman 2nd 54719, *d.* Red Rosette 3rd (vol. xxxv. p. 551) *by* Blairmore 49156.
- 746 R. N.—THE DUKE OF PORTLAND, Welbeck Abbey, Notts, for **Donovan**. H. C.—H.R.H. THE PRINCE OF WALES, K.G. for No. 731, **Lord Fauntleroy**; H. J. SHELDON for No. 749, **Duke of Brailes 15th**.  
Com.—HER MAJESTY THE QUEEN for No. 730, **Field Officer**; J. B. GREEN for No. 738, **Cherry Duke**; THE DUKE OF NORTHUMBERLAND for No. 743, **Royal Rover**; WM. TRETHERY for No. 750, **Pol**.

Class 58.—*Shorthorn Bulls calved in 1890.* [33 entries, 10 absent.]

- 762 I. (£20 & R. N. for Champion.<sup>1</sup>)—WILLINGHAM FOWLER, Exton, Oakham, for **Eryholme Prince 35th**, roan, born Apr. 10; *s.* Lord Broughton 56029, *d.* Zeal 36th (vol. xxxvi. p. 402) *by* M.C. 31898.
- 760 II. (£10.)—F. J. SAVILE FOLJAMBE, Osberton Hall, Worksop, for **Claude Melnotte**, roan, born Jan. 8; *s.* Feudal Chief 51251, *d.* Pauline 28th (vol. xxxiv. p. 352) *by* Bright Prince 49191.
- 758 III. (£5.)—J. DEANE-WILLIS, Bapton Manor, Codford, Wilts, for **Baron Bridekirk 3rd**, roan, born Jan. 3, bred by J. Barnes, Wigton; *s.* Prosperity 54876, *d.* Bridekirk 8th (vol. xxxvi. p. 273) *by* Red Prince 46960.

<sup>1</sup> Piece of Plate value £25 given by the Shorthorn Society for the best Male Shorthorn.

[Unless otherwise stated, each prize animal named below was "bred by exhibitor."]

- 772 **R. N. & H. C.**—THE DUKE OF NORTHUMBERLAND, for **King Alfred**.  
**H. C.**—HER MAJESTY THE QUEEN for No. 754, **Fairfax**; THE DUKE OF NORTHUMBERLAND for No. 773, **Village Chief**.  
**Com.**—MASKILL & STRICKLAND for No. 769, **Field Marshal 2nd**; THE DUKE OF PORTLAND for No. 777, **St. Serf**; H. J. SHELDON for No. 781, **Duke of Barrington 34th**.

**Class 59.**—*Shorthorn Cows (in-milk or in-calf), calved before 1888.*  
 [7 entries, 1 absent.]

- 792 **I.** (£15.)—LORD POLWARTH, Mertoun House, St. Boswells, N.B., for **Wave of Indiana**, red & white, born Feb. 13, 1887; s. King Alfonso 49803, d. Wave of Pacific (vol. xxxvi. p. 526) by Rapid Rhone 35205.  
 791 **II.** (£10.)—LORD POLWARTH, for **Wave of Loch Leven** (vol. xxxvi. p. 599), red & white, born Feb. 14, 1886, calved Jan. 19, 1891; s. King David 43417, d. Wave of Pacific by Rapid Rhone 35205.  
 787 **III.** (£5.)—C. W. BRIERLEY, Rosedale, Tenbury, for **Marchioness of Waterloo 6th**, roan, born Aug. 21, 1886, bred by W. H. Tremaine, Sherborne, Northleach; s. Earl of Oxford 51185, d. Waterloo Marchioness (vol. xxix. p. 730) by Duke of Waterloo 3rd 23801.  
 789 **R. N. & H. C.**—J. B. GREEN, Low House Farm, Silsden, for **Strawberry 12th**.  
**Com.**—F. J. SAVILE FOLJAMBE for No. 788, **White Rose**; JONAS WEBB for No. 793, **Waterloo Cherry**.

**Class 60.**—*Shorthorn Heifers (in-milk or in-calf), calved in 1888.*  
 [9 entries, 2 absent.]

- 801 **I.** (£15 & Champion £25.<sup>1</sup>)—LORD POLWARTH, Mertoun House, St. Boswells, N.B., for **Truth** (vol. xxxv. p. 526) red & white, born Apr. 12, calved Feb. 3, 1891; s. Sir Arthur Irwin 44016, d. Timbrel by Prince Stuart 45421.  
 798 **II.** (£10.)—WM. GRAHAM, Eden Grove, Penrith, for **Windsor's Beauty**, roan, born Feb. 19, calved-Jan. 8, 1891, bred by R. Thompson, Inglewood, Penrith; s. Model 53322, d. Home Beauty 3rd (vol. xxxii. p. 593) by British Sovereign 36285.  
 800 **III.** (£5.)—THE DUKE OF NORTHUMBERLAND, Alnwick Castle, for **Fairy Rosebud** (vol. xxxv. p. 506), roan, born Mar. 29, calved March 1, 1891; s. King Hal 49808, d. Studley Rosebud by Royal Studley 45548.  
 802 **R. N. & H. C.**—ROBERT THOMPSON, Inglewood, for **Baroness Millicent**.  
 799 **H. C.**—THE EARL OF LISBURNE, Crosswood, Aberystwith, for **Fair Helen**.  
**Com.**—F. J. SAVILE FOLJAMBE for No. 796, **Pamela**; A. M. GORDON for No. 797, **Marietta**.

**Class 61.**—*Shorthorn Heifers, calved in 1889.*  
 [19 entries, 6 absent.]

- 815 **I.** (£15 & R. N. for Champion.<sup>1</sup>)—LORD POLWARTH, Mertoun House, St. Boswells, N.B., for **Gladstone Wave** (vol. xxxvi. p. 594), roan, born Apr. 17; s. Patrician 54785, d. Crystal Wave by King Stephen 46559.  
 803 **II.** (£10.)—HER MAJESTY THE QUEEN, The Prince Consort's Shaw Farm, Windsor, for **Rosalind** (vol. xxxvi. p. 240), roan, born Feb. 12; s. Field Marshal 47870, d. Ruth 201st by Star of Britain 48786.  
 805 **III.** (£5.)—J. DEANE-WILLIS, Bapton Manor, Codford, Wilts, for **Lady Madge**, red, born Mar. 22, bred by Wm. Duthie, Tarves; s. Norseman 56233, d. Lady Marjory 3rd (vol. xxxiv. p. 327) by Field Marshal 47870.

<sup>1</sup> Piece of Plate value £25 given by the Shorthorn Society for the best Female Shorthorn.



[Unless otherwise stated, each prize animal named below was "bred by exhibitor."]

- 811 **R. N. & H. C.**—WM. HOSKEN & SON, for **Lady Blithfield 6th**.  
**H. C.**—J. DEANE-WILLIS for No. 806, **Rose of Collynie**; THE DUKE OF NORTHUMBERLAND for No. 814 **Lady Lucy**.  
**Com.**—F. J. SAVILE FOLJAMBE for No. 808, **Fendal Rose**; R. & G. HARRISON for No. 809, **Rosemary**; F. C. STARKIE for No. 816, **Merry Millicent**; THOMAS STOKES for No. 817, **Gladys Rose 3rd**; and No. 818, **Gladys Waterloo**; RICHARD STRATTON for No. 819, **Cowslip 18th**; JONAS WEBB for No. 821, **Prima Donna**.

**Class 62.**—*Shorthorn Heifers, calved in 1890.* [27 entries, 8 absent.]

- 834 **I.** (£15.)—R. & G. HARRISON, Underpark, Lealholm, Grosmont, Yorkshire, for **Fern 8th**, roan, born Jan. 14; s. Prince Magnus 56333, d. Fern 7th (vol. xxxvi. p. 436) by Donald 52725.  
 822 **II.** (£10.)—HER MAJESTY THE QUEEN, The Prince Consort's Shaw Farm, Windsor, for **Rosemary**, roan, born Jan. 10; s. Field Marshal 47870, d. Ruth 210th (vol. xxxvi. p. 240) by King Bolivar 48096.  
 829 **III.** (£5.)—J. DEANE-WILLIS, Bapton Manor, Codford, Wilts, for **Vinolia**, roan, born July 2; s. Challenge Cup 57029, d. Viola by Asteroid 49023.  
 844 **R. N. & H. C.**—R. STRATTON, The Duffryn, Newport, Mon., for **Jubilee Gem**.  
 830 **H. C.**—J. DEANE-WILLIS for **Carnation**.  
**Com.**—D. COOPER for No. 827, **Lady Yarborough**, and No. 828, **Lady Agnes**; JONAS WEBB for No. 845, **Cherry Oxford 13th**; H. WILLIAMS for No. 846, **Maritana**.

## Herefords.

**Class 63.**—*Hereford Bulls, calved in 1885, 1886, 1887, or 1888.*  
 [8 entries, 1 absent.]

- 850 **I.** (£20.)—W. H. COOKE, The Green, Shelsley Kings, Worcester, for **Grove Wilton 4th** 13846, born Mar. 12, 1888; s. Grove Wilton 3rd 11295, d. Leinthall Symmetry by Downton Grand Duke 5878.  
 851 **II.** (£10.)—THE EARL OF COVENTRY, Croome Court, Severn Stoke, for **White Boy** 13534, born Feb. 17, 1887; s. Good Boy 7668, d. White Rose 3rd by Patriot 5494.  
 849 **III.** (£5.)—J. H. ARKWRIGHT, Hampton Court, Leominster, for **Spring Jack** 14191, born Jan. 2, 1888; s. Hilarity 8734, d. Lively 10th by Conjuror.  
 853 **R. N. & H. C.**—RALPH PALMER, for **Bombardier** 12869.  
**Com.**—R. EDWARDS for No. 852, **Shaftesbury**; JAMES RANKIN, M.P., for No. 855, **Royalist**; J. A. ROLLS for No. 856, **Veracity**.

**Class 64.**—*Hereford Bulls, calved in 1889.* [8 entries, 3 absent.]

- 858 **I.** (£20.)—J. H. ARKWRIGHT, Hampton Court, Leominster, for **Rose Cross 2nd** 14865, born Jan. 21; s. Iroquois 3rd 13147, d. Curly 25rd by Rose Cross 7237.  
 860 **II.** (£10.)—A. E. HUGHES, Wintercott, Leominster, for **Ironclad** 14628, born Jan. 12; s. Hiero 7707, d. Lofty by Rudolph 6660.  
 863 **III.** (£5.)—STEPHEN ROBINSON, Lynhales, Kington, for **Sterling**, born Feb. 23; s. Rose Stock 6651, d. White Spark 3rd by Horatius 5390.  
 862 **R. N. & H. C.**—JAMES RANKIN, M.P., Bryngwyn, Tram Inn, for **Forester**.  
 857 **Com.**—HER MAJESTY THE QUEEN, for **Matadore**, born Feb. 17.

[Unless otherwise stated, each prize animal named below was "bred by exhibitor."]

**Class 65.**—*Hereford Bulls, calved in 1890.* [14 entries, 5 absent.]

- 867 **I.** (£20.)—A. E. HUGHES, Wintercott, Leominster, for **Albion**, born Jan. 5, bred by N. F. Moore, Pantalls, Sutton, Herefordshire; s. Bruce 13646, *d.* Milenda *by* Recorder 7205.
- 873 **II.** (£10.)—JAMES RANKIN, M.P., Bryngwyn, Tram Inn, for **Blucher**, born Jan. 21; s. Bear 10974, *d.* Blush *by* Cicero 11077.
- 876 **III.** (£5.)—H. W. TAYLOR, Showle Court, Ledbury, for **Sanfoin**, born Feb. 8; s. Admiral 12797, *d.* Echo *by* Franklin 6961.
- 875 **R. N.**—H. W. TAYLOR for **Hero**, born Jan. 21.

**Class 66.**—*Hereford Cows or Heifers (in-milk or in-calf), calved before or in 1888.* [6 entries, none absent.]

- 879 **I.** (£15.)—THE EARL OF COVENTRY, Croome Court, Severn Stoke, for **Ladywood**, born Jan. 2, 1887, calved Jan. 25, 1891; s. Adelbert 8185, *d.* Lady Spencer *by* Monkton Lad 5646.
- 882 **II.** (£10.)—THOMAS FENN, Stonebrook House, Ludlow, for **Bravura** (vol. xxi. p. 339), born May 17, 1886, calved Feb. 9, 1891, bred by the Earl of Coventry; s. Good Boy 7668, *d.* Bertha *by* Commander 4452.
- 881 **III.** (£5.)—THOMAS FENN, for **Downton Fancy** (vol. xx. p. 315), born Jan. 9, 1888, calved Oct. 13, 1890; s. Bourton 11005, *d.* Lady Buttercup *by* Moonraker 3rd 6077.
- 880 **R. N. & H. C.**—R. EDWARDS, The Sheriffs, Kington, for **Sheriff's Sunlight**.
- 883 **Com.**—REES KEENE, Llanvihangel Court, Chepstow, for **Choice Bangham**.

**Class 67.**—*Hereford Heifers, calved in 1889.* [8 entries, 2 absent.]

- 891 **I.** (£15.)—RICHARD GREEN, The Whittern, Kington, for **Diana** (vol. xxi. p. 364), born Apr. 1; s. Whittern Grove 10843, *d.* Duchess 5th *by* Corsair.
- 890 **II.** (£10.)—E. S. GODSELL, Stroud, for **Sunbeam** (vol. xxi. p. 366), born Feb. 10, bred by R. Green, Kington; s. Washington 2nd 11834, *d.* Silver Weed *by* Rose Stock 6651.
- 887 **III.** (£5.)—THE EARL OF COVENTRY, Croome Court, Severn Stoke, for **Golden Fleece**, born Jan. 27; s. Rare Sovereign 10499, *d.* Golden Fortune *by* Adelbert 8185.
- 888 **R. N. & H. C.**—T. FENN, Stonebrook House, Ludlow, for **Downton Hermia**.
- Com.**—COL. R. BRIDGFORD, C.B., for No. 886, **Philomel**; THOMAS FENN for No. 889, **Fine Lady**.

**Class 68.**—*Hereford Heifers, calved in 1890.* [18 entries, 6 absent.]

- 899 **I.** (£15.)—RICHARD GREEN, The Whittern, Kington, for **Perilla**, born Jan. 8; s. Whittern Grove 10843, *d.* Miss Perfection *by* Lord Wilton.
- 894 **II.** (£10.)—COL. R. BRIDGFORD, C.B., Kinnersley, Hereford, for **Sybil**, born Jan. 10; s. Torro 7313, *d.* Dairymaid (vol. xxi. p. 237) *by* Ruby 6659.
- 903 **III.** (£5.)—RALPH PALMER, Lodge Farm, Nazeing, Waltham Cross, for **Lucifer**, born Feb. 6; s. Crown Prince 8464, *d.* Lightfoot *by* Rose Stock.
- 901 **R. N. & H. C.**—HENRY HAYWOOD for **Truth**; **H. C.** for No. 900 **Sequel**.
- Com.**—HER MAJESTY THE QUEEN for No. 893, **Bessie**; REES KEENE for No. 902, **Blanche Ravenspur**; JAMES RANKIN, M.P., for No. 908, **Damsel 2nd**.

[Unless otherwise stated, each prize animal named below was "bred by exhibitor."]

### Devons.

**Class 69.**—*Devon Bulls, calved in 1886, 1887, or 1888.*

[5 entries, 2 absent.]

- 915 **I.** (£15.)—SIR WM. WILLIAMS, Bt., Heanton, Barnstaple, for **Captain 2204**, born Oct. 14, 1887; s. Foreman 1968, d. Georgina.  
 911 **II.** (£10.)—JOHN HOWSE, Stamborough, Washford, Taunton, for **Shamrock 2311**, born June 11, 1887; s. Druid 1317, d. Lily 4th 6206 by Lily's Robin 1582.  
 913 **R. N. & H. C.**—ALFRED C. SKINNER, for **Duke of Pound 16th**, 2391.

**Class 70.**—*Devon Bulls, calved in 1889 or 1890.*

[9 entries, 3 absent.]

- 924 **I.** (£15.)—SIR WM. WILLIAMS, Bt., Heanton, Barnstaple, for **Pretty Middling**, born Oct. 18, 1889, bred by the late Viscount Falmouth; s. Lord Wolseley 2063, d. Quadrille, by Sirloin.  
 922 **II.** (£10.)—J. C. WILLIAMS, Caerhays, St. Austell, for **Doncaster**, born Jan. 16, 1890; s. Duke of Flitton 17th 1544, d. Dowager 8784 by Bravo 1686.  
 921 **III.** (£5.)—JOHN TREMAYNE, Sydenham, Lew Down, Devon, for **Lovely Laddie 2612**, born Mar. 3, 1889; s. Bravo 1686, d. Lovely Lady 7247 by Sir Michael 1646.  
 919 **R. N. & H. C.**—JOHN HOWSE, Stamborough, for **Lord Stamborough**.  
**Com.**—JOHN FARTHING for No. 917, **Robin's Tempter**, and No. 918, **Prolific's Duke**.

**Class 71.**—*Devon Cows or Heifers (in-milk or in-calf), calved before or in 1888.* [3 entries, none absent.]

- 927 **I.** (£15.)—SIR WM. WILLIAMS, Bt., Heanton, Barnstaple, for **Flame 3rd 9932**, born Mar. 2, 1887, calved Jan. 6, 1891; s. Eclipse 1728, d. Famous 4th by Lord Stowey.  
 926 **II.** (£10.)—ALFRED C. SKINNER, Pound Farm, Bishop's Lydeard, Som., for **Rosebud 10447**, born Feb. 9, 1888, calved Jan. 24, 1891; s. General Gordon 1974, d. Moss Rose 8th 7017 by Lord Stowey 1601.  
 925 **R. N.**—ALFRED C. SKINNER for **Duchess 17th 8988**, born June 14, 1886.

**Class 72.**—*Devon Heifers, calved in 1889 or 1890.*

[7 entries.]

- 934 **I.** (£15.)—SIR WM. WILLIAMS, Bt., Heanton, Devon, for **Fiction 2nd 11108**, born Apr. 9, 1889; s. Foreman 2nd 1969, d. Fiction by Duke of Flitton 17th.  
 930 **II.** (£10.)—JOHN FARTHING, Currypool, Bridgwater, Som., for **Prolific 13th 11409**, born June 28, 1890; s. Baronet 1897, d. Prolific 2nd 6286.  
 929 **III.** (£5.)—THE EARL OF DARTMOUTH, Patshull, Wolverhampton, for **Dasher 10687**, born May 17, 1889; s. Lord Stowey 1601, d. Dairymaid.  
 933 **R. N. & H. C.**—ALFRED C. SKINNER, for **Lady Passmore 7th 11015**.  
**H. C.**—HER MAJESTY THE QUEEN for No. 928, **Gossamer**; JOHN FARTHING for No. 931, **Robin's Duchess 9th**; JOHN HOWSE for No. 932, **Cowslip 2nd**.

### Sussex.

**Class 73.**—*Sussex Bulls, calved in 1886, 1887, or 1888.*

[2 entries, 1 absent.]

- 936 **I.** (£15.)—C. T. LUCAS, Warnham Court, Horsham, for **Golden Horn 754**, born Apr. 14, 1886; s. Goldsmith 391, d. Lavant 4th 2881 by Robinson Crusoe 361.

[Unless otherwise stated, each prize animal named below was "bred by exhibitor."]

**Class 74.**—*Sussex Bulls, calved in 1889 or 1890.*

[10 entries, 1 absent.]

- 941 **I.** (£15.)—JOSEPH GODMAN, Park Hatch, Godalming, for **Oxford Duke 4th** 1014, born Feb. 20, 1889; *s.* Oxford Duke 708, *d.* Noble Lady 2911 *by* Napoleon 3rd 396.
- 942 **II.** (£10.)—J. STEWART HODGSON, Lythe Hill, Haslemere, for **Rochester** 1114, born Mar. 28, 1889; *s.* Silversmith 849, *d.* Peace 2nd 2916 *by* Royal Kilburn 401.
- 940 **III.** (£5.)—W. S. FORSTER, Gore Court, Maidstone, for **Gondolier** 1001, born Apr. 19, 1889; *s.* Careful 741, *d.* Tidy *by* Berry.
- 943 **R. N. & H. C.**—J. STEWART HODGSON, for **Silversmith 2nd** 1115.
- 946 **H. C.**—LOUIS HUTH for **Lord Beckley 13th**, born May 18, 1889.

**Class 75.**—*Sussex Cows or Heifers (in-milk or in-calf), calved before or in 1888.* [7 entries, 2 absent.]

- 951 **I.** (£15.)—J. STEWART HODGSON, Lythe Hill, Haslemere, for **Peace 6th** 4108, born Jan. 13, 1887; *s.* Prince Rufus 515, *d.* Peace 2nd 2916 *by* Royal Kilburn 401.
- 949 **II.** (£10.)—W. S. FORSTER, Gore Court, Maidstone, for **Black Eyes** 4388, born Aug. 5, 1888; *s.* Goldsmith 391, *d.* Surprise 3116 *by* Archduke 381.
- 952 **III.** (£5.)—LOUIS HUTH, Possingworth Manor, Waldron, for **Virgin 23rd** 4448, born Dec. 31, 1887; *s.* Lord Beckley 6th 700, *d.* Virgin 8th 2723 *by* Sir William 471.
- 950 **R. N. & H. C.**—W. S. FORSTER, for **Damsel** 4712, born April 18.

**Class 76.**—*Sussex Heifers, calved in 1889 or 1890.*

[13 entries, 4 absent.]

- 955 **I.** (£15.)—MAJOR BEST, Park House, Boxley, Maidstone, for **Pearl** 4625, born Jan. 1, 1889; *s.* Goldsmith 391, *d.* Alice *by* Mr. Wickham's bull.
- 965 **II.** (£10.)—GEORGE WHITE, Hunton, Maidstone, for **Ninon**, born Mar. 24, 1889; *s.* Ruby 2nd 721, *d.* Nelly *by* Sweet William 369.
- 960 **III.** (£5.)—J. STEWART HODGSON, Lythe Hill, Haslemere, for **Crocus 3rd** 4808, born Jan. 4, 1889; *s.* Silversmith 849, *d.* Crocus 2nd 2349 *by* Hereford 263.
- 957 **R. N. & H. C.**—W. S. FORSTER for **Pixie** 4704, born Mar. 23, 1889.
- H. C.**—T. BANNISTER for No. 954, **Limehurst Ruby**; JOSEPH GODMAN, for No. 958, **Noble Lady 7th**; LOUIS HUTH for No. 961, **Lilly 14th**; C. T. LUCAS for No. 962, **Verity 3rd**, and for No. 963, **Cora**.

## Welsh.

**Class 77.**—*Welsh Bulls, calved in 1888, 1889, or 1890.*

[5 entries, none absent.]

- 967 **I.** (£10.)—LORD HARLECH, Glyn, Talsarnan, for **Master Tom**, born Jan. 4, 1889; *s.* Tichborne 160, *d.* Rosebud *by* Black Prince 4.
- 970 **II.** (£5.)—COL. HENRY PLATT, Gorddinog, Llanfairfechan, for **Roger** 199, born June 15, 1888; *s.* Molyng 196, *d.* Princess Joan *by* Welsh Duke 3rd 59.
- 971 **R. N. & H. C.**—MAJOR SANDBACH, Hafodunos, Abergele, for **Sir Mona Com.**—W. E. OAKELEY for No. 968, **Baron of Tan-y-Bwlch**; COL. HENRY PLATT for No. 969, **Llwarth**.

[Unless otherwise stated, each prize animal named below was "bred by exhibitor."]

**Class 78.**—*Welsh Cows or Heifers, of any age (in-milk or in-calf).*  
[5 entries, none absent.]

- 976 **I.** (£10.)—COL. HENRY PLATT, Gorddinog, Llanfairfechan, for **Blodwen 2nd**, born Mar. 4, 1889; *s.* Bromfield 191, *d.* Blodwen by Grand Duke 22.  
975 **II.** (£5.)—COL. HENRY PLATT, for **Tudno 588**; born May 8, 1887, calved Apr. 6, 1891; *s.* Ap Gwilym 70, *d.* Princess of Wales 81.  
972 **B. N. & H. C.**—WM. E. OAKELEY for **Famous 300**; **H. C.**—for No. 973, **Model**, and for No. 974, **Kitty Oakeley**.

## Red Polled.

**Class 79.**—*Red Polled Bulls, calved in 1886, 1887, or 1888.*  
[4 entries, none absent.]

- 978 **I.** (£15 & Champion, £10 10s.<sup>1</sup>)—J. J. COLMAN, M.P., Carrow House, Norwich, for **Bardolph 977**, born Jan. 23, 1886; *s.* Falstaff 303, *d.* Silent Woman 2537 by Rufus 188.  
977 **II.** (£10 & **B. N.** for Champion.<sup>1</sup>)—W. A. TYSSEN AMHERST, M.P., Didlington Hall, Brandon, for **Masher 1232**, born Apr. 9, 1887; *s.* Morella 895, *d.* Didlington Davy 2148 by Davyson 7th 476.  
979 **B. N. & H. C.**—LORD HASTINGS for **Disturbance**; and **Com.** for No. 980, **Viceroy**.

**Class 80.**—*Red Polled Bulls, calved in 1889 or 1890.*  
[4 entries.]

- 982 **I.** (£15.)—J. J. COLMAN, M.P., Carrow House, Norwich, for **The Gem 1832**, born Apr. 24, 1889; *s.* Iago 1025, *d.* Rosella 4333 by Falstaff 303.  
983 **II.** (£10.)—MRS. PERKINS, Saham Hall, Watton, for **Saham Davyson 2nd 2038**, born Apr. 17, 1889; *s.* Davyson 15th 652, *d.* Handsome of Broom Hill 2866 by Cortes 645.  
981 **III.** (£5.)—W. A. TYSSEN AMHERST, M.P., Didlington Hall, Brandon, for **Red Shirt 2014**, born May 28, 1889, bred by T. Fulcher, Elmham; *s.* Frantic 1381, *d.* Violet 3rd 4427 by Lancer 689.  
984 **B. N. & Com.**—MRS. PERKINS for **Mr. Pickwick 1953**, born Jan. 18, 1889.

**Class 81.**—*Red Polled Cows or Heifers (in-milk or in-calf), calved before or in 1888.* [10 entries, 2 absent.]

- 990 **I.** (£15.)—H. P. GREEN, Caistor Hall, Norwich, for **Gleam 3rd 4925**, born Dec. 10, 1888, calved May 3, 1891; *s.* The Viking 959, *d.* Gleam 4564 by Roundhead 564.  
986 **II.** (£10.)—W. A. TYSSEN AMHERST, M.P., Didlington Hall, Brandon, for **Poppety 2nd 4289**, born Feb. 22, 1887, calved Feb. 24, 1891; *s.* Didlington Davyson 2nd 657, *d.* Poppinette 2455 by Davyson 3rd 48.  
989 **III.** (£5.)—J. J. COLMAN, M.P., Carrow House, Norwich, for **Buttercup 3908**, born Feb. 13, 1887, calved Feb. 12, 1891; *s.* Falstaff 303, *d.* Brunette 2044 by King Charles 329.  
985 **B. N. & H. C.**—W. A. TYSSEN AMHERST, M.P., for **Emblem 2782**.  
991 **H. C.**—DUKE OF HAMILTON & BRANDON, K.T., for **Best of Battersea's**.  
993 **Com.**—R. H. MASON, Necton Hall, Swaffham, for **Empress 3rd**.

<sup>1</sup> Given by the Red Polled Society for the best Red Polled animal exhibited.

[Unless otherwise stated, each prize animal named below was "bred by exhibitor."]

**Class 82.—Red Polled Heifers, calved in 1889 or 1890.**

[12 entries, 2 absent.]

- 1005 **I.** (£15).—MRS. PERKINS, Saham Hall, Watton, for **Ivy 3rd** 5563, born Mar. 27, 1889; s. Davyson 15th 652, d. Ivy 2262 by Othello 532.
- 1002 **II.** (£10).—A. G. LUCAS, Ashlyns, Berkhamsted, for **Donna Anna** 5410, born Jan. 5, 1889; s. Don Carlos 659, d. Annie 1985 by Bounty 460.
- 1003 **III.** (£5).—R. HARVEY MASON, Necton Hall, Swaffham, for **Ruthless** 5939, born Jan. 25, 1889; s. Erebus 841, d. Ruth 3129 by Starston Duke.
- 998 **R. N. & H. C.**—H. P. GREEN, Caistor Hall, Norwich, for **Ultrada 2nd**.  
**H. C.**—J. J. COLMAN, M.P., for No. 997, **Dorena**; and **Com.** for No. 996, **Twin Sister**. **Com.**—THE DUKE OF HAMILTON AND BRANDON, K.T., for No. 999, **Keepsake**.

**Aberdeen-Angus.**

**Class 83.—Aberdeen-Angus Bulls, calved in 1886, 1887, or 1888.**

[4 entries.]

- 1008 **I.** (£15).—ARTHUR EGGINTON, South Ella, Hull, for **Epsom** 7507, born Dec. 23, 1888, bred by Sir G. Macpherson Grant, Bart., Ballindalloch; s. Plutarch 5632, d. Elfin 3795 by Elcho 595.
- 1010 **II.** (£10).—CLEMENT STEPHENSON, Sandyford Villa, Newcastle-on-Tyne, for **Albion** 6525, born Feb. 3, 1888; s. Souter Johnny 1615, d. Abbess 3rd 3616 by Blue Beard 648.
- 1009 **III.** (£5).—J. D. FLETCHER, Rosehaugh House, Inverness, for **Prince of Euston** 7851, born Mar. 7, 1888; s. Euston of Ballindalloch 3716, d. Pride of Altyre 5th 5593 by Black Watch 1242.
- 1007 **R. N. & H. C.**—MAJOR DENT, Menethorpe, Malton, for **Knight Errant**.

**Class 84.—Aberdeen-Angus Bulls, calved in 1889 or 1890.**

[10 entries, none absent.]

- 1014 **I.** (£15).—J. T. CATHCART, Pitcairnie, Auchtermuchty, Fife, for **Julius Cæsar** 7637, born Apr. 21, 1889; s. Norfolk 3082, d. Lady Jane Grey 10065 by Monarch 1182.
- 1019 **II.** (£10).—CLEMENT STEPHENSON, Sandyford Villa, Newcastle-on-Tyne, for **Albert Edward** 7293, born Jan. 31, 1889; s. Souter Johnny 1615, d. Abbess 3rd 3616 by Blue Beard 648.
- 1020 **III.** (£5).—JOHN STUART, Stone Hurst, Ardingly, Sussex, for **Financier of Ballindalloch** 8328, born Dec. 16, 1889, bred by Sir G. Macpherson Grant, Bt., Ballindalloch; s. Plutarch 5632, d. Lady Flush 12438 by Erroll 2723.
- 1013 **R. N. & H. C.**—REV. C. BOLDEN, for **Esmond of Ballindalloch**.
- 1016 **Com.**—J. D. FLETCHER, for **Ameer of Rosehaugh**.

**Class 85.—Aberdeen-Angus Cows or Heifers (in-milk or in-calf), calved before or in 1888. [7 entries, 1 absent.]**

- 1023 **I.** (£15).—THE MARQUIS OF HUNTLY, Aboyne Castle, N.B., for **St. Agnes** 13839, born Jan. 1, 1887, calved Mar. 29, 1891; s. Frederick The Great 4680, d. St. Anna 8768 by Wedgewood 2109.
- 1022 **II.** (£10).—THE MARQUIS OF HUNTLY, for **St. Agatha** 13838, born Jan. 2, 1888; s. Frederick The Great 4680, d. St. Anna 8768 by Wedgewood.

[Unless otherwise stated, each prize animal named below was "bred by exhibitor."]

- 1027 **III.** (£5.)—OWEN C. WALLIS, Bradley Hall, Wylam-on-Tyne for **Maria of Haughton 12th** 12306, born Jan. 22, 1887, bred by the late R. O. Farquharson, Haughton, N.B.; s. Arbitor of Glenbarry 3432, *d.* Maria of Haughton 6th 6839 *by* The Black Knight 1809.
- 1025 **R. N. & H. C.**—P. STIRLING OF KIPPENDAVIE, for **Fenella of Kippendavie**.
- 1026 **Com.**—OWEN C. WALLIS for **Althea** 11917.

**Class 86.**—*Aberdeen-Angus Heifers, calved in 1889 or 1890.*

[6 entries, 1 absent.]

- 1030 **I.** (£15.)—ARTHUR EGGINTON, South Ella, Hull, for **Valentine 5th** 14867, born Mar. 28, 1889; s. Fuschius 3762, *d.* Valentine of South Ella 11091 *by* Edile 2709.
- 1032 **II.** (£10.)—THE DUKE OF PORTLAND, Welbeck Abbey, for **Blue Stocking** 15715, born Jan. 22, 1889, bred by the Earl of Strathmore, Glamis Castle, N.B.; s. Alister 1939, *d.* Blanche of Glamis 6176 *by* Elcho 595.
- 1029 **III.** (£5.)—T. DIXON, JUN., Leadhill, Stocksfield-on-Tyne, for **Lady Florid** 15055, born May 28, 1889, bred by Sir G. Macpherson Grant, Bt., Ballindalloch; s. Errol 2723, *d.* Lady Florence 2985 *by* Ballimore 741.
- 1033 **R. N. & H. C.**—P. STIRLING OF KIPPENDAVIE, for **Ruby 6th of Kippendavie**.

## Galloways.

**Class 87.**—*Galloway Bulls, calved in 1886, 1887, or 1888.*

[2 entries.]

- 1034 **I.** (£15.)—THE DUKE OF BUCCLEUCH AND QUEENSBERRY, K.T., Drumlanrig Castle, N.B., for **Bosphorus** 4693, born Feb. 8, 1888; s. The Squire of Drumlanrig 3737, *d.* Pride of Drumlanrig *by* The Baron of Drumlanrig.
- 1035 **II.** (£10.)—THE DUKE OF BUCCLEUCH AND QUEENSBERRY, K.T., for **Vich Ian Vohr** 4121, born Feb. 17, 1886, bred by F. E. Villiers, Closeburn Hall, Thornhill, N.B.; s. John Highlandman 1905, *d.* Forest Queen of Closeburn *by* Sim of Whitram.

**Class 88.**—*Galloway Bulls, calved in 1889 or 1890.*

[4 entries, 1 absent.]

- 1036 **I.** (£15.)—JAMES CUNNINGHAM, Tarbreoch, Dalbeattie, for **Macdougall 2nd of Tarbreoch** 5064, born Apr. 29, 1889; s. Harden 1151, *d.* Maggie of Tarbreoch *by* Scottish Borderer.
- 1037 **II.** (£10.)—JAMES CUNNINGHAM, for **Cedric of Tarbreoch** 5060, born Jan. 3, 1889; s. Scottish Borderer 669, *d.* Tarbreoch Lizzie 3rd *by* Harden 1151.
- 1038 **III.** (£5.)—SIR ROBERT JARDINE, Bt., M.P., Castlemilk, Lockerbie, for **Black Douglas of Castlemilk** 5002, born Aug. 26, 1889; s. Bard of Castlemilk 4416, *d.* Lady Isabella Douglas of Nether Hall *by* Robin Gray.

**Class 89.**—*Galloway Cows or Heifers (in-milk or in-calf), calved before or in 1888.* [8 entries, 2 absent.]

- 1046 **I.** (£15.)—JAMES CUNNINGHAM, Tarbreoch, Dalbeattie, for **Maggie of Tarbreoch** 8613, born Mar. 17, 1884, calved Feb. 16, 1891; s. Scottish Borderer 669, *d.* Maggie of Blackpark *by* Sandy of Lairdlough.
- 1041 **II.** (£10.)—THE COUNTESS OF CARLISLE, Naworth Castle, Brampton, for **Vaudeville of Closeburn** 8134, born Jan. 3, 1884, calved Nov. 24, 1890, bred by F. E. Villiers, Closeburn Hall, Thornhill, N.B.; s. John Highlandman of Closeburn 1905, *d.* Fancy of Closeburn 3794 *by* Statesman 630.

[Unless otherwise stated, each prize animal named below was "bred by exhibitor."]

- 1040 **III.** (£5).—THE DUKE OF BUCCLEUCH AND QUEENSBERRY, K.T., Drumlanrig Castle, Thornhill, N.B., for **Pride 4th of Drumlanrig** 10337, born Jan. 20, 1887, calved Feb. 28, 1891; *s.* Squire of Drumlanrig 3737, *d.* Pride of Drumlanrig by Baron of Drumlanrig.
- 1042 **R. N. & H. C.**—COUNTESS OF CARLISLE, for **Vendetta 2nd of Closeburn**.  
**Com.**—JAMES CUNNINGHAM for No. 1044, **Lady Stanley 10th**; LORD POLWARTH for No. 1047, **Emerald of Nether Hall**.

**Class 90.**—*Galloway Heifers, calved in 1889 or 1890.*

[10 entries, 1 absent.]

- 1056 **I.** (£15).—SIR ROBERT JARDINE, Bart., M.P., Castlemilk, Lockerbie, for **Lady Tidy 3rd of Castlemilk** 11962, born Jan. 31, 1890; *s.* Liberator 3850, *d.* Lady Tidy by Garnet of Hardland.
- 1052 **II.** (£10).—JAMES CUNNINGHAM, Tarbreoch, Dalbeattie, for **Scottish Queen** 11524, born June 22, 1889; *s.* Harden 1151, *d.* Lizzie 4th of Breckonhill by Scottish Borderer.
- 1057 **III.** (£5).—SIR ROBERT JARDINE, Bart., M.P., for **Jenny Duke 5th of Castlemilk** 11499, born Apr. 28, 1889; *s.* Liberator of Balig 3850, *d.* Jenny Duke by Duke of Drumlanrig.
- 1054 **R. N. & H. C.**—JAMES CUNNINGHAM, for **Mary Graham** 11595.
- 1050 **Com.**—THE COUNTESS OF CARLISLE for **Vaudeville 3rd of Closeburn**.

**Ayrshires.**

**Class 91.**—*Ayrshire Bulls, calved in 1888, 1889, or 1890.* [3 entries.]

- 1060 **I.** (£10).—MARK J. STEWART, M.P., Southwick, Dumfries, for **Hover of Southwick**, white with spots, born Feb. 3, 1889; *s.* Hover o' Blink 892, *d.* Eva of Drumlanrig 666 by Prince Charlie.
- 1059 **II.** (£5).—MARK J. STEWART, M.P., for **Blooming Heather** 1918, white with dark spot, born Mar. 1889, bred by R. Osborne, Drumjoan, Ochiltree; *s.* Craigs of Kyle 1793, *d.* Nancy of Drumjoan by Hover o' Blink 892.
- 1058 **R. N. & H. C.**—ANDREW MITCHELL, for **Lord of the Isles** 1873.

**Class 92.**—*Ayrshire Cows or Heifers of any age (in-milk or in-calf).*

[4 entries, 1 absent.]

- 1062 **I.** (£10).—ANDREW MITCHELL, Barcheskie, Kirkcudbright, N.B., for **Eleanor**, brown & white, born Apr. 20, 1889, bred by Mrs. Mair, Shalloch, *s.* Traveller 1441, *d.* Bardy.
- 1064 **II.** (£5).—ANDREW MITCHELL, for **Beauty of Barcheskie**, brown & white, born Mar. 26, 1886, calved June 10, 1891, bred by T. Barbour, Parkthorn; *s.* The Doctor 1646, *d.* Rosy 1st by Brownhill.
- 1063 **R. N. & H. C.**—ANDREW MITCHELL, for **Louisa 1st of Barcheskie**.

**Jerseys.**

**Class 93.**—*Jersey Bulls, calved in 1887, 1888, or 1889.*

[32 entries, 8 absent.]

- 1078 **I.** (£15).—J. W. CROOKES, Hayston Hall, Haverfordwest, for **Pomona's Daily** (Sup. vii. p. 40), brown, born April 24, 1889; *s.* Pomona's Boy 2774, *d.* La Presse by Forget-me-not 1595.



[Unless otherwise stated, each prize animal named below was "bred by exhibitor."]

- 1080 **II. (£10).**—SIR R. GRAHAM, Bart., Norton Conyers, Ripon, for **Norton Nero**, black, born June 26, 1889; s. Fan's Nero 2433, *d.* Diana *by* Nero du Coin I.H.B. 463.
- 1073 **III. (£5).**—W. E. BUDGETT, Stoke Bishop, Bristol, for **Roseberry**, brown, born Aug. 20, 1888, bred by T. H. Weetman, Atherstone; s. Magnum Bonum 1792, *d.* Roseleaf *by* Milk Boy 561.
- 1090 **B. N. & H. C.**—LORD ROTHSCHILD, Tring Park, Herts, for **Columbus**. **H. C.**—WM. ARKWRIGHT for No. 1065, **Marmalade**; JAMES BLYTH for No. 1068, **Runner**, and No. 1070, **Grouville's Champion**; JOSEPH BRUTTON for No. 1072, **Vulcan**; EDWIN CASH for No. 1075, **Augerez Nelson**, and No. 1077, **Grouville's Mannikin**; THE EARL OF LONDESBOROUGH for No. 1084, **Bacchus**.
- Com.**—W. BARRON for No. 1067, **Viola's Boy**; EDWIN CASH for No. 1076, **Rosa's Wonder**; A. E. MCMULLEN for No. 1087, **Reigate**; R. J. STREATFIELD for No. 1093, **The Baron**.

**Class 94.—Jersey Bulls, calved in 1890. [32 entries, 7 absent.]**

- 1115 **I. (£15).**—MRS. MCINTOSH, Havering Park, Romford, for **Penny Come Quick** I.H.B. 1469 H.C., grey, born Feb. 24, bred by J. T. Michel, Beaumont, St. Peter's, Jersey; s. Hillside Lad I.H.B. 1163, *d.* Brown Flower I.H.B. 2645 *by* Royal Khedive I.H.B. 628.
- 1123 **II. (£10).**—LORD ROTHSCHILD, Tring Park, for **Gift**, brown, born March 30, bred by J. T. Michel, St. Peter's, Jersey; s. Sir Thomas I.H.B. 1125, *d.* Marleybone I.H.B. 3493.
- 1105 **III. (£5).**—P. H. FOWLER, Watford, for **Bird** I.H.B. 1482 P.S.H.C., grey, born Feb. 10, bred by C. De Gruchy, Trinity, Jersey; s. Taunton Hero 1166 P.S.H.C., *d.* Bay Leaf 2nd 1450 P.C. *by* Guénore's Pride 347 P.S.H.C.
- 1114 **B. N. & H. C.**—EARL OF LONDESBOROUGH, for **Grouville's Dairyman**. **H. C.**—J. R. CORBETT for No. 1101, **Jacky**; FOWLER & DE LA PERRELLE for No. 1107, **Cloth of Gold**; A. E. MCMULLEN for No. 1117, **Rosy's Carnot**.
- Com.**—J. W. CROOKES for No. 1103, **Milkyway**, and No. 1103A, **Rosy's Crown**; J. E. GROOM for No. 1108, **Irving**; THE HON. MRS. CECIL HOWARD for No. 1112, **Hophornbeam**; THE EARL OF LONDESBOROUGH for No. 1113, **Darius**; A. E. MCMULLEN for No. 1118, **Lord Doncaster**; and for No. 1119, **Wolseley's Romeo**; LORD ROTHSCHILD for No. 1124, **President**.

**Class 95.—Jersey Cows (in-milk), calved before or in 1887. [26 entries, 2 absent.]**

- 1129 **I. (£15).**—JAMES BLYTH, Wood House, Stansted, for **Lady Safety**, fawn & white, born Jan. 10, 1886, calved June 3, 1891, bred by E. Vardon, St. Martin's, Jersey; s. Royal Khedive 2863, *d.* Safety I.H.B. 2338.
- 1143 **II. (£10).**—EARL OF LONDESBOROUGH, Londesborough Park, Yorks, for **Precoce II.** (E.H.B. vol. iv. p. 537), fawn, born Feb. 20, 1883, calved May 11, 1891, bred by T. Mourant, Trinity, Jersey; s. Colonel Hardy 2343, *d.* Precoce I.H.B. 3442 F.S.C.
- 1128 **III. (£5).**—WM. ARKWRIGHT, Sutton Scarsdale, Chesterfield, for **Carillon** I.H.B. 7470 F.S., grey fawn, born Aug. 16, 1885, calved Apr. 26, 1891, bred by J. A. Gibaut, Trinity, Jersey; s. Egcon I.H.B. 420 F.S., *d.* Concorde 2772 F.S. *by* Brown Prince 130 F.S.

[Unless otherwise stated, each prize animal named below was "bred by exhibitor."]

- 1137 **R. N. & H. C.**—J. W. CROOKES, for **Golden Crown I.H.B. 6524 F.S.**  
**H. C.**—WM. ALEXANDER, JUN., for No. 1127, **Graceful Maid**; JAMES BLYTH for No. 1130, **Phillippa**; T. L. BROWN for No. 1132, **Columbine**; JOSEPH BRUTTON for No. 1133, **Bay Leaf 4th**; H. J. CORNISH for No. 1135, **Linda's Belle**, and No. 1136, **Young Rosebay**; THE HON. MRS. CECIL HOWARD for No. 1141, **Hips**; R. J. STREATFIELD for No. 1149, **Lucy**.  
**Com.**—JAMES BLYTH for No. 1131, **Sweet Secret**; J. W. CROOKES for No. 1138, **Light of Grouville**; G. W. HASTINGS, M.P., for No. 1140, **Lady Hardy**; MRS. A. F. PERKINS for No. 1145, **Wigton**; LORD ROTHSCHILD for No. 1146, **Alfriston Duchess**, and for No. 1148, **Brebis 3rd**; MRS. SWAN for No. 1151, **Amoureuse**; C. J. H. TOWER for No. 1152, **Belle Bergère**.

**Class 96.**—*Jersey cows (in-milk), calved in 1888.*

[25 entries, 7 absent.]

- 1154 **I** (£15).—W. BARRON, Sefton Park, Slough, for **Lady of the Lake 4th**, grey fawn, born Feb. 8, calved May 18, 1891, bred by P. F. Le Gresley, St. Owen's, Jersey; s. Leonidas I.H.B. 881, d. **Lady of the Lake 4188**.  
 1157 **II**. (£10).—JAMES BLYTH, Wood House, Stansted, for **Princess Alice**, silver grey, born Feb. 20, calved May 29, 1891, bred by J. T. Michel, St. Peter's, Jersey; s. Pollux I.H.B. 871, d. **Alice 4th I.H.B. 526**.  
 1159 **III**. (£5).—JOSEPH BRUTTON, Yeovil, for **Mabel 21st**, brown, born Jan. 15, calved May 14, 1891, bred by W. J. Labey, Grouville, Jersey; s. Sultanne's Favourite I.H.B. 873, d. **Mabel 3rd 179 by Sans Peur 201**.  
 1158 **R. N. & H. C.**—T. LOADER BROWN, Halffield, Chard, for **Brookhill Violet**.  
**H. C.**—W. ALEXANDER, JUN., for No. 1153, **Beauvoir Favourite**; H. J. CORNISH for No. 1160, **Little Mecca**; THE HON. MRS. CECIL HOWARD for No. 1165, **Honewort**; LORD ROTHSCHILD for No. 1175, **Wigton 2nd**; R. J. STREATFIELD for No. 1176, **Leah**.  
**Com.**—JAMES BLYTH for No. 1156, **Jersey Skater 4th**; FOWLER & DE LA PERRELLE for No. 1161, **Florida**; A. E. MCMULLEN for No. 1168, **Pride 2nd**; MAISONETTE DAIRY CO. for No. 1170, **Linda's Belle 2nd**, and for No. 1171, **Quiver**; LORD ROTHSCHILD for No. 1173, **Chansonette**; R. TANFIELD for No. 1177, **Daisy**.

**Class 97.**—*Jersey Heifers (in-milk or in-calf), calved in 1889.*

[37 entries, 8 absent.]

- 1189 **I**. (£15).—H. J. CORNISH, Thornford, Sherborne, for **Miranda**, brown, born Feb. 1, calved June 5, 1891, bred by F. Le Brocq, St. Peter's, Jersey; s. Lord Nelson I.H.B. 900, d. **Slipper I.H.B. 2862**.  
 1186 **II**. (£10).—JOSEPH BRUTTON, Yeovil, for **Golden Lass 7th**, brown, born Feb. 4, bred by J. P. Marett, St. Saviour's, Jersey; s. Sultanne's Favourite I.H.B. 873, d. **Golden Lass I.H.B. 5711**.  
 1182 **III**. (£5).—S. BAXENDALE, Bonningtons, Ware, for **Berberis**, whole colour, born Apr. 16, calved Apr. 6, 1891; s. **Young Neptune 1847**, d. **Bracken by Jersey King 1706**.  
 1199 **R. N. & H. C.**—G. W. HASTINGS, M.P., for **Good Rose**.  
**H. C.**—W. ALEXANDER, JUN., for No. 1178, **Albertina**, and for No. 1180, **Jenny Lind 2nd**; JAMES BLYTH for No. 1183, **Burma 2nd**, and for No. 1184, **Laura Hardcastle**; H. J. CORNISH for No. 1190, **Success**; J. E. GROOM for No. 1198, **Victorine**; THE HON. MRS. CECIL HOWARD for No. 1202, **Zara**; MRS. MCINTOSH for No. 1203, **Lady Musgrave 3rd**; C. J. H. TOWER for No. 1214, **Badier's Louisa**.

[Unless otherwise stated, each prize animal named below was "bred by exhibitor."]

**Com.**—W. ALEXANDER, JUN., for No. 1179, *Circassienne*; R. BARRINGER for No. 1181, *Minnehaha*; JAMES BLYTH for No. 1185, *Miracle 3rd*; W. E. BUDGETT for No. 1187, *Fairy II*, and for No. 1188, *Prima Donna II*; P. H. FOWLER for No. 1194, *Sybyl*; FOWLER & DE LA PERBELLE for No. 1197, *May Queen 2nd*; A. E. McMULLEN for No. 1206, *Maid of the Mill*; MAISONETTE DAIRY CO. for No. 1209, *Nubia*; R. J. STREATFIELD for No. 1212, *Scilla*, and for No. 1213, *Seamew*.

**Class 98.**—*Jersey Heifers, calved in 1890.* [40 entries, 3 absent.]

- 1250 **I.** (£15).—LORD ROTHSCHILD, Tring Park, for *Pontorson 2nd*, grey, born May 5; s. Pandora's Boy, d. Pontorson I.H.B. 1875 P.S.H.C. by Happy Cetewayo I.H.B. 2499.
- 1223 **II.** (£10).—EDWIN CASH, St. John's College, Cambridge, for *Mamie*, grey fawn, born June 1; s. Castor, d. Mabel S. by Wolsey's Glory 2nd.
- 1226 **III.** (£5).—J. W. CROOKES, Hayston Hall, Haverfordwest, for *Bessie Black*, fawn, born Aug. 26; s. Rosy's Carlo, d. Black Bess 2nd by Perrot I.H.B. 342 P.S.
- 1227 **R. N. & H. C.**—J. W. CROOKES, for *Daisy Chain*, fawn & white; s. Poster.
- H. C.**—W. E. BUDGETT for No. 1221, *Beauty 7th*; J. W. CROOKES for No. 1226, *Bessie Black*; THE EARL OF LONDESBOROUGH for No. 1238, *Castanet*; MAISONETTE DAIRY CO. for No. 1244, *Mysterious Girl 6th*; MRS. A. F. PERKINS for No. 1248, *Freya*; MRS. STARKIE for No. 1252, *Grouffle*.
- Com.**—R. BARRINGER for No. 1215, *Lilly Bligh*; W. BARRON for No. 1216, *Lily's Joy*; JOSEPH BRUTTON for No. 1220, *Jealousy*; W. E. BUDGETT for No. 1222, *Daisy 4th*; H. J. CORNISH for No. 1225, *Cosey*; THE EARL OF FEVERSHAM for No. 1231, *Ruby 34th*; G. W. HASTINGS, M.P., for No. 1232, *Fiery Cross 3rd*; THE HON. MRS. CECIL HOWARD for No. 1234, *Hempseed*; A. E. McMULLEN for No. 1242, *Little Handy 3rd*; LORD ROTHSCHILD for No. 1251, *Young Butterfly*; MRS. STARKIE for No. 1253, *Grouville's Fancy*; R. J. STREATFIELD for No. 1254, *Sensitive*.

## Guernseys.

**Class 99.**—*Guernsey Bulls, calved in 1887, 1888 or 1889.*  
[11 entries, none absent.]

- 1256 **I.** (£15).—W. CHRISTIE-MILLER, Broomfield, Chelmsford, for *Our Prince 424* E.G.H.B., fawn & white, born Jan. 30, 1889, bred by J. Druce, St. Martin's, Guernsey; s. Sir Francis, d. Oasis 2nd.
- 1262 **II.** (£10).—H. M. OZANNE, Lilyvale, Castel, Guernsey, for *Bingleader 590* P.S., R.G.A.S., fawn & white, born Nov. 12, 1889; s. Advantage 463 P.S., R.H.B., d. Unity 1576 F.S., R.H.B., by Golden Fleece 214.
- 1264 **III.** (£5).—COL. H. W. SHAKERLEY, Fairlight, Hastings, for *Paradox 352*, pale fawn & white, born Feb. 21, 1888, bred by P. Martel, Mare, Castel, Guernsey; s. Marc Antony 386 P.S., R.G.A.S., d. May Rose 2nd.
- 1258 **R. N. & H. C.**—COL. ALEX. C. MACLEAY, for *Papageno 351* E.G.H.B.
- 1261 **Com.**—SIR F. MONTEFIORE, Bt., Worth Park, Crawley, for *Lord Worth*.

**Class 100.**—*Guernsey Bulls, calved in 1890.* [7 entries, 2 absent.]

- 1268 **I.** (£15).—W. A. GLYNN, Seagrove, Seaview, Ryde, for *The General*, orange fawn & little white, born Feb. 15; s. Hopeful 25 E.G.H.B., d. Fairy 3rd 106.

[Unless otherwise stated, each prize animal named below was "bred by exhibitor."]

- 1267 **II.** (£10).—THE HON. MRS. A. BAILLIE HAMILTON, Combs, Stowmarket, for **Jesse 2nd** 406 E.G.H.B., fawn & white, born Aug. 8; s. **Loyalist** 103 E.G.H.B., d. **Jessie** 5th 582 E.G.H.B. by **First Lord** 93 E.G.H.B.]
- 1271 **III.** (£5).—SIR F. MONTEFIORE, Bart., Worth Park, Crawley, for **Emperor** 399 E.G.H.B., fawn & white, born Aug. 18; s. **Black Prince** 291, d. **Florey** 1291.
- 1266 **R. N.**—THE HON. MRS. A. BAILLIE HAMILTON, for **Remus** 431 E.G.H.B.

**Class 101.**—*Guernsey Cows or Heifers (in-milk), calved before or in 1888.* [9 entries, none absent.]

- 1278 **I.** (£15).—SIR F. MONTEFIORE, Bart., Worth Park, Crawley, for **Fortuna** 758 E.G.H.B., orange & white, born Apr. 18, 1886, calved May 4, 1891, bred by A. Rintoul, jun., Junior Carlton Club; s. **Hopeful** 25, d. **Blossom** 21.
- 1279 **II.** (£10).—JULIAN STEPHENS, Grove House, Finchley, for **Muriel** 1132 E.G.H.B., orange fawn & white, born Sept. 12, 1888, calved Nov. 28, 1890, bred by H. Abrahams, St. Peter's Port, Guernsey; s. **Climax** 14 E.G.H.B., d. **Whitey**.
- 1273 **III.** (£5).—THE HON. MRS. A. BAILLIE HAMILTON, Combs, Stowmarket, for **Romaine 3rd** 270 E.G.H.B., red fawn, born Oct. 22, 1882, calved May 24, 1891; s. **Prince of Vauxbelets**, d. **Romaine 2nd** by **Bijou**.
- 1277 **R. N. & H. C.**—W. A. GLYNN, Seagrove, Seaview, Ryde, for **Honesty 2nd**.  
**H. C.**—THE HON. MRS. A. BAILLIE HAMILTON for No. 1274, **Polly 2nd**;  
P. H. FOWLER for No. 1275, **Beauty de la Maison d'Haut**.

**Class 102.**—*Guernsey Heifers, calved in 1889 or 1890.*  
[24 entries, 3 absent.]

- 1297 **I.** (£15).—SIR F. MONTEFIORE, Bart., Worth Park, Crawley, for **Volunteer** 1769 E.G.H.B., fawn & white, born Jan. 1889, bred by T. Mahy, Capelles, Guernsey; s. **Fréluquet** 40 P.S., R.G.A.S., d. **La Grosse Roup** 1790 R.G.A.S.
- 1298 **II.** (£10).—H. M. OZANNE, Lilyvale, Castel, Guernsey, for **Lillie of the Forest 2nd** 2182 R.G.H.B., red & white, born Jan. 25, 1889, bred by J. G. Browning, Carrefour, St. Andrew's, Guernsey; s. **Fréluquet** 400 P.S., d. **Lillie of the Forest** 858 P.S.
- 1288 **III.** (£5).—FOWLER & DE LA PERRELLE, Southampton, for **Queen of the Fields** 3873 G.H.B., lemon & white, born Jan. 27, 1889, bred by T. Mahy, Guernsey; s. **Rydall** 214, d. **Jessie des Landes** 3231.
- 1304 **R. N. & H. C.**—R. TANFIELD, Cherry Burton, Hull, for **Dairy Maid 2nd**.  
**H. C.**—P. H. FOWLER for No. 1287, **Alpine Rosette**; FOWLER & DE LA PERRELLE for No. 1289, **Lady Evora**; H. M. OZANNE for No. 1299, **Evening Star**.  
**Com.**—W. CHRISTIE-MILLER for No. 1285, **Vesta 28th**, and No. 1286, **Vesta 29th**; COL. A. C. MACLEAY for No. 1292, **Iolanthe 2nd**, and for No. 1293, **Esther**.

**Kerries.**

**Class 103.**—*Kerry Bulls, calved in 1888, 1889 or 1890.*  
[8 entries, 2 absent.]

- 1311 **I.** (£10).—MARTIN J. SUTTON, Kidmore Grange, Caversham, for **Kidmore Prince**, born June 5, 1890; s. **Moonlighter 2nd** 92, d. **Flora** 13 by **Shann-an-Scoup**.

[Unless otherwise stated, each prize animal named below was "bred by exhibitor."]

- 1306 **II.** (£5.)—CHARLES ADEANE, Babraham Hall, Cambridge, for **Blackamoor**, born May 17, 1890; s. Shiplake Knight 104, d. Blackberry 2nd 161.

**Class 104.**—*Kerry Cows or Heifers, of any age (in-milk or in-calf).*  
[17 entries, 6 absent.]

- 1928 **I.** (£10.)—MARTIN J. SUTTON, Kidmore Grange, Caversham, for **Peep** 732, age unknown, calved Feb. 22, 1891, breeder unknown.  
1924 **II.** (£5.)—THE MARQUIS OF LANSDOWNE, Bowood, Calne, for **Enda** 368, born 1887, breeder unknown.  
1321 **R. N. & H. C.**—H. FOARD HARRIS, Brooke House, Fleet, for **Maynooth**.  
**H. C.**—H. FOARD HARRIS for No. 1320, **Carton**; MARTIN J. SUTTON for No. 1330, **Flora**.

### Dexter Kerries.

**Class 105.**—*Dexter Kerry Bulls, calved in 1888, 1889 or 1890.*  
[11 entries, 3 absent.]

- 1331 **I.** (£10.)—LORD ASHBURTON, The Grange, Alresford, for **Chang** 1154, born Oct., 1888, bred by Richard Barter, St. Ann's Hill, Cork.  
1339 **II.** (£5.)—MARTIN J. SUTTON, Kidmore Grange, Caversham, for **Othello** 17, born Apr. 26, 1889; s. Paradox 18, d. Rosemary 4.  
1341 **R. N. & H. C.**—HAROLD SWITHINBANK, for **Denham Lord Lurgan**.  
1334 **H. C.**—H. D. D. BETTERIDGE, for **Gladiator**, born 1888.

**Class 106.**—*Dexter Kerry Cows or Heifers of any age (in-milk or in-calf).* [22 entries, 7 absent.]

- 1343 **I.** (£10.)—LORD ASHBURTON, The Grange, Alresford, for **Queen Mab** 1150, born May 1883, calved Jan. 18, 1891, breeder unknown.  
1362 **II.** (£5.)—HAROLD SWITHINBANK, Denham Court, Bucks, for **Denham Lady Limerick**, born about 1885, calved Mar. 25, 1891, breeder unknown.  
1361 **R. N. & H. C.**—MARTIN J. SUTTON, for **Peach** 161, born 1884.  
**H. C.**—H.R.H. THE PRINCE OF WALES, K.G., for No. 1342, **Arum**; LORD ASHBURTON for No. 1344, **Lady Kilmorna**, and for No. 1345, **Mavourneen**; MARTIN J. SUTTON for No. 1359, **Pride of Erin**, and for No. 1360, **Red Rose**; HAROLD SWITHINBANK for No. 1363, **Denham Lady Lisburn**.

### DAIRY CATTLE.

**Class 107.**—*Dairy Cows, in-milk, of any breed or cross, giving the greatest quantity of milk containing not less than 12 per cent. Solids, and 3 per cent. Butter Fat.* [12 entries, 1 absent.]

**Class 107a.**—*Cow, of 1100 lb. or over, live weight.*

- 1366 **I.** (£15.)—J. BRAMMER, Wheatly, Doncaster, for **Dairyman's Pride** (cross-bred), roan, born July 9, 1886, calved Apr. 25, 1891, breeder unknown.  
1369 **II.** (£10.)—GEORGE CHURCH, Road Farm, Willington, Bedford, for **Nancy** (Shorthorn), red, born about 1886, calved June 2, 1891.  
1368 **III.** (£5.)—GEORGE CHURCH, for **Miss Cope** (Shorthorn), roan & white, born about 1886, calved Apr. 6, 1891, breeder unknown.

[Unless otherwise stated, each prize animal named below was "bred by exhibitor."]

**Class 107b.**—*Cow, under 1100 lb., live weight.*

- 1373 **I.** (£15.)—MRS. SWAN, Stonefield, Lincoln, for **Daystar 2nd** (Jersey), grey fawn, born Sept. 8, 1880, calved Apr. 1, 1891, bred by W. A. Peel, Rickmansworth; *s.* Dysart 1068, *d.* Daystar.
- 1364 **II.** (£10.)—S. BAXENDALE, Bonningtons, Ware, for **Blossom** (Jersey), whole colour, born July 11, 1887, calved May 2, 1891; *s.* Wolseley's Glory 2nd 2169, *d.* Bloom by Young Neptune 1847.
- 1369A **III.** (£5.)—GEORGE CHURCH, Road Farm, Willington, Bedford, for **Flower**, born about 1886, calved May 25, 1891, breeder unknown.

**SHEEP.**

**Leicesters.**

**Class 108.**—*Leicester Two-Shear Rams.* [8 entries, 1 absent.]

- 1379 **I.** (£15.)—T. H. HUTCHINSON, Manor House, Catterick, born Mar. 1889.
- 1381 **II.** (£10.)—E. F. JORDAN, Eastburn, Driffield, born Apr. 1889.
- 1380 **III.** (£5.)—T. H. HUTCHINSON, born Mar. 1889.
- 1377 **R. N. & H. C.**—R. & G. HARRISON, born Apr. 1889.
- 1382 **H. C.**—E. F. JORDAN, born Apr. 1889.

**Class 109.**—*Leicester Shearling Rams.* [13 entries, 4 absent.]

- 1391 **I.** (£15.)—T. H. HUTCHINSON, Manor House, Catterick, born Mar. 1890.
- 1387 **II.** (£10.)—R. & G. HARRISON, Underpark, Lealholm, Grosmont, Yorks, born Mar. 1890, bred by J. & D. Linton, Bedale.
- 1385 **III.** (£5.)—JOHN DOWSON, Danby Castle, Yorks, born Mar. 4, 1890.
- 1393 **R. N.**—E. F. JORDAN, Eastburn, Driffield, born Apr. 1890.

**Class 110.**—*Pen of Three Leicester Ram Lambs, dropped in 1891.*  
[9 entries, 1 absent.]

- 1403 **I.** (£10.)—E. F. JORDAN, Eastburn, Driffield, born Mar.
- 1404 **II.** (£5.)—MRS. PERRY-HERRICK, Beau Manor Park, Loughborough, born about Mar. 16.
- 1397 **R. N. & H. C.**—J. B. GREEN, Silsden, Yorks. 1401 **H. C.**—T. H. HUTCHINSON.

**Class 111.**—*Pen of Three Leicester Shearling Ewes, of the same flock.*  
[6 entries, 1 absent.]

- 1407 **I.** (£15.)—E. F. JORDAN, Eastburn, Driffield, b. Apr. 1890, & 1408 **II.** (£10.)
- 1409 **III.** (£5.)—MRS. PERRY-HERRICK, Beau Manor Park, Loughborough, born about Mar. 16, 1890.
- 1406 **R. N. & H. C.**—R. & G. HARRISON and **H. C.** for No. 1405, born March.

**Cotswolds.**

**Class 112.**—*Cotswold Two-Shear Rams.* [7 entries, 1 absent.]

- 1415 **I.** (£15.)—R. SWANWICK, R. A. C. Farm, Cirencester, born Feb. 14, 1889.
- 1416 **II.** (£10.)—RUSSELL SWANWICK, born Feb. 14, 1889.

[Unless otherwise stated, each prize animal named below was "bred by exhibitor."]

- 1413 **III.** (£5.)—R. GARNE, Aldsworth, Northleach, born Mar. 1889.  
 1411 **R. N. & H. C.**—G. BAGNALL & SON, Westwell Manor, Oxon., born Feb. 1889.  
 1414 **H. C.**—R. GARNE. 1412 **Com.**—G. BAGNALL & SON.

**Class 113.**—*Cotswold Shearling Rams.* [9 entries, none absent.

- 1421 **I.** (£15.)—R. GARNE, Aldsworth, Northleach, born Feb. 1890.  
 1419 **II.** (£10.)—G. BAGNALL & SON, Westwell Manor, Burford, born Feb.  
 1424 **III.** (£5.)—RUSSELL SWANWICK, R. A. C. Farm, Cirencester, born Feb.  
 1422 **R. N. & H. C.**—R. GARNE, Aldsworth, Northleach, born Feb. 1890.  
**H. C.**—RUSSELL SWANWICK, for Nos. 1425 & 1426, born Feb. 1, 1890.  
 1423 **Com.**—R. GARNE, Aldsworth, Burford, born Feb. 1890.

**Class 114.**—*Pen of Three Cotswold Ram Lambs, dropped in 1891.*  
 [5 entries, 1 absent.]

- 1428 **I.** (£10) & 1429 **II.** (£5.)—R. GARNE, Aldsworth, Northleach, born Feb.  
 1431 **R. N. & H. C.**—R. SWANWICK, R. A. C. Farm, Cirencester, born Feb. 14.

**Class 115.**—*Pen of Three Cotswold Shearling Ewes, of the same flock.*  
 [3 entries.]

- 1432 **I.** (£15.)—G. BAGNALL & SON, Westwell Manor, Burford, born Feb.  
 1433 **II.** (£10.)—G. BAGNALL & SON, born Jan. 1890.  
 1434 **R. N. & H. C.**—G. BAGNALL & SON, born Feb. 1890.

## Lincolns.

**Class 116.**—*Lincoln Two-Shear Rams.* [7 entries, 1 absent.]

- 1437 **I.** (£15.)—HENRY DUDDING, Riby Grove, born abt. Mar. 14, 1889,  
 bred by J. Needham, Uttoft.  
 1441 **II.** (£10.)—ROBERT WRIGHT, Nocton Heath, Lincoln, born Feb. or  
 Mar. 1889, bred by Tom Caswell, Pointon.  
 1435 **III.** (£5) & 1436 **R. N. & H. C.**—HENRY DUDDING, born abt. Mar. 14, 1889.  
 1438 **H. C.**—G. T. MELBOURN, Nocton Heath, Lincoln, born Mar. 28, 1889.

**Class 117.**—*Lincoln Shearling Rams.* [29 entries, 2 absent.]

- 1470 **I.** (£15.)—ROBERT WRIGHT, Nocton Heath, Lincoln, born Feb. or Mar.  
 1449 **II.** (£10) and 1450 **III.** (£5.)—HENRY DUDDING, Riby Grove, Grimsby  
 born abt. Mar. 14, 1890.  
 1463 **R. N. & H. C.**—JOHN PEARS, Mere, Lincoln, born Feb. 1890.  
**H. C.**—WM. HESSELTINE for No. 1459; WM. ROE for No. 1467; ROBERT  
 WRIGHT for No. 1469.  
**Com.**—HENRY DUDDING for No. 1451; WM. HESSELTINE for No. 1460.

**Class 118.**—*Pen of Three Lincoln Ram Lambs, dropped in 1891.*  
 [11 entries, 3 absent.]

- 1475 **I.** (£10) & 1473 **II.** (£5.)—H. DUDDING, Riby Grove, Lincs, b. abt. Feb. 14.  
 1479 **R. N. & H. C.**—JOHN WESTBOPE, Morden Hall, Royston, born January.  
**H. C.**—T. BROWN for No. 1472; JOHN PEARS for No. 1478.

[Unless otherwise stated, each prize animal named below was "bred by exhibitor."]

**Class 119.**—*Pen of Three Lincoln Shearling Ewes, of the same flock.*  
[10 entries, 1 absent.]

- 1490 **I.** (£15.)—ROBERT WRIGHT, Nocton Heath, Lincoln, born Feb. or Mar.  
1484 **II.** (£10.)—HENRY DUDGING, Riby Grove, Grimsby, born abt. Mar. 14.  
1491 **III.** (£5.)—ROBERT WRIGHT, born Feb. or Mar. 1890.  
1485 **R. N. & H. C.**—HENRY DUDGING, born abt. March 14, 1890.  
**H. C.**—HENRY GOODYEAR for No. 1486; JOHN PEARS for No. 1489.

## Oxford Downs.

**Class 120.**—*Oxford Down Two-Shear Rams.* [4 entries, 1 absent.]

- 1492 **I.** (£15.)—JOHN C. EADY, Irchester Grange, Wellingborough, for **Cambridge Swell**, born abt. Feb. 15, 1889; *s.* Favourite 157, *d. by* Bicester 121.  
1495 **II.** (£10.)—JOHN TREADWELL, Upper Winchendon, Bucks, for **Royal Plymouth**, born Feb. 1889; *s.* Brassey's 22 (217), *d. by* Royal Preston 128.  
1493 **R. N. & H. C.**—CHARLES HOWARD, Biddenham, Bedford, for **Biddenham 3**.

**Class 121.**—*Oxford Down Shearling Rams.* [20 entries, 6 absent.]

- 1513 **I.** (£15.)—JOHN TREADWELL, Upper Winchendon, Bucks, born about Feb. 14, 1890; *s.* Irchester Vicar 373, *d. by* Young Freeland 107.  
1514 **II.** (£10.)—JOHN TREADWELL, born Feb. 1890; *s.* Grand Lord 639, *d. by* Young Comet 122.  
1515 **III.** (£5.)—JOHN TREADWELL, born Feb. 1890.  
1512 **R. N. & H. C.**—G. STREET, Maulden, Amptill, for **Maulden Prince Royal**.  
1501 **H. C.**—A. BRASSEY, Heythrop Park, Chipping Norton, born Jan. 20.  
**Com.**—ALBERT BRASSEY for Nos. 1502 & 1503; CHARLES HOWARD for No. 1504; FREDERIC STREET for No. 1510.

**Class 122.**—*Pen of Three Oxford Down Ram Lambs, dropped in 1891.*  
[7 entries, none absent.]

- 1518 **I.** (£10.)—A. BRASSEY, Heythrop Park, Chipping Norton, born Jan. 14 & 15.  
1516 **II.** (£5.)—GEORGE ADAMS, Pidnell, Faringdon, born abt. Jan. 13; *s.* Burser 2nd 587, *d. by* Fyfield Duke.  
1517 **R. N. & H. C.**—GEORGE ADAMS, born abt. Jan. 13; *s.* Burser 2nd 587.  
**Com.**—ALBERT BRASSEY for No. 1519; W. J. P. READING for Nos. 1520 & 1521; FREDERIC STREET for No. 1522.

**Class 123.**—*Pen of Three Oxford Down Shearling Ewes, of the same flock.* [8 entries, none absent.]

- 1528 **I.** (£15.)—J. C. EADY, Irchester Grange, Wellingborough, born abt. Feb. 15, 1890; *ss.* Favourite 157 & Young Cultivator 540, *d. by* Irchester Comet 691.  
1527 **II.** (£10.)—ALBERT BRASSEY, Heythrop Park, Chipping Norton, born Jan. 16 and 18, 1890; *s.* Compton 1st 244.  
1523 **III.** (£5.)—GEORGE ADAMS, Pidnell, Faringdon, born abt. Jan. 13, 1890; *s.* Burser 2nd 587, *d. by* Fyfield Duke.  
1529 **R. N. & H. C.**—FREDERIC STREET, Somersham Park, St. Ives, Hunts, born about Feb. 14, 1890; *s.* Somersham Duke 473.  
**Com.**—GEORGE ADAMS for Nos. 1524 & 1525; JOHN TREADWELL for No. 1530.



[Unless otherwise stated, each prize animal named below was "bred by exhibitor."]

## Shropshires.

### Class 124.—*Shropshire Two-Shear Rams.* [29 entries, 3 absent.]

- 1548 I. (£15).—GEORGE LEWIS, Ercall Park, Wellington, Salop, born Mar. 10, 1889; *s.* Time Keeper 3763, *d.* by Call Again 1382.
- 1535 II. (£10).—A. S. BERRY, Pheasey Farm, Gt. Barr, Birmingham, for Barr Chief 4357, born Mar. 1889.
- 1532 III. (£5).—MRS. BARRS, Odstone Hall, Atherstone, born Mar. 1889.
- 1541 R. N. & H. C.—D. BUTTAR, Corston, Coupar Angus, for Baron Dundee.  
H. C.—JOHN HARDING for No. 1545; W. F. INGE for No. 1546, *Pride of Thorpe*; A. E. MANSELL for Nos. 1549 & 1550; GEORGE THOMPSON for No. 1558, *Lord Rowington*.
- Com.—A. BRADBURNE for No. 1538, *Knave of Diamonds*; R. P. COOPER for No. 1543, *West Pride*; W. F. INGE for No. 1547, *Noble Patron*.

### Class 125.—*Shropshire Shearling Rams.* [98 entries, 15 absent.]

- 1597 I. (£15).—W. F. INGE, Thorpe Hall, Tamworth, born about Feb. 18.
- 1573 II. (£10).—T. & S. BRADBURNE, Astwood Hill, Redditch, born Mar. 10, 1890; *s.* Precentor.
- 1562 III. (£5).—MRS. MARIA BARRS, Odstone Hall, Atherstone, born Mar.
- 1629 R. N. & H. C.—E. NOCK, Brockton House, Shifnal, born Mar. 1890.  
H. C.—MRS. BARRS for Nos. 1560 & 1561; A. S. BERRY for No. 1563; DAVID BUTTAR for No. 1581; R. P. COOPER for No. 1587; G. GRAHAM for Nos. 1591 & 1593; W. F. INGE for Nos. 1598 & 1599; A. E. MANSELL for No. 1611; P. A. MUNTZ, M.P., for No. 1623; J. L. NAPER for Nos. 1626 & 1627; H. TOWNSHEND for No. 1654; M. WILLIAMS for No. 1656.
- Com.—G. COOKE for Nos. 1583 & 1584; G. GRAHAM for No. 1592; JOHN HARDING for No. 1594; A. E. MANSELL for No. 1610; P. A. MUNTZ, M.P., for No. 1624; G. THOMPSON for No. 1651, *Superior*.

### Class 126.—*Pen of Three Shropshire Ram Lambs, dropped in 1891.* [24 entries, 7 absent.]

- 1663 I. (£10).—R. BROWN, Ruyton-Eleven-Towns, Shrewsbury, brn. Mar. & Apr.
- 1681 II. (£5).—GEORGE THOMPSON, Mousley End House, Wroxall, born Mar. 1; *s.* Lord Rowington, *d.* Bonny Face by Georgius.
- 1667 R. N. & H. C.—R. P. COOPER, Shenstone Ct., Lichfield, born Feb. and Mar.  
H. C.—T. & S. BRADBURNE for No. 1661; W. F. INGE for No. 1670; A. E. MANSELL for No. 1674. Com.—GEORGE LEWIS for No. 1671.

### Class 127.—*Pen of Three Shropshire Shearling Ewes, of the same flock.* [31 entries, 8 absent.]

- 1683 I. (£15).—MRS. MARIA BARRS, Odstone Hall, Atherstone, born Mar. 1890
- 1694 II. (£10).—W. F. INGE, Thorpe Hall, Tamworth, born abt. Feb. 20, 1890.
- 1687 III. (£5).—T. & S. BRADBURNE, Astwood Hill, Redditch, born Mar. 10, 1890; *s.* Precentor.
- 1693 R. N. & H. C.—G. GRAHAM, Oaklands, Birmingham, born Mar. 1890.  
H. C.—J. BOWEN-JONES for No. 1685; W. F. INGE for No. 1695; T. S. MINTON for No. 1700; P. A. MUNTZ, M.P., for No. 1702; E. NOCK for No. 1703.
- Com.—B. H. BROOKSBANK for No. 1688; GEORGE LEWIS for No. 1696.

[Unless otherwise stated, each prize animal named below was "bred by exhibitor."]

## Southdowns.

### Class 128.—*Southdown Two-Shear Rams.* [12 entries, 3 absent.]

- 1714 I. (£15).—H.R.H. THE PRINCE OF WALES, K.G., born Mar. 1889.  
 1715 II. (£10).—J. J. COLMAN, M.P., Carrow House, Norwich, born Feb. 26.  
 1721 III. (£5).—THE DUKE OF RICHMOND AND GORDON, K.G., Goodwood, Sussex, born Feb. 1889.  
 1718 R. N. & H. C.—THE DUKE OF HAMILTON AND BRANDON, K.T.

### Class 129.—*Southdown Shearling Rams.* [35 entries, 4 absent.]

- 1731 I. (£15).—J. J. COLMAN, M.P., Carrow Ho., Norwich, born Feb. 27, 1890.  
 1725 II. (£10).—H.R.H. THE PRINCE OF WALES, K.G., born Mar. 1890.  
 1730 III. (£5).—JAMES BLYTH, Wood House, Stansted, born Feb. 1890.  
 1755 R. N. & H. C.—SIR WM. THROCKMORTON, Bt., Buckland, Faringdon.  
 H. C.—J. J. COLMAN, M.P., for No. 1732; A. DE MURRIETA for No. 1733;  
 A. HEASMAN for No. 1741; THE DUKE OF RICHMOND AND GORDON, K.G., for No. 1752.

### Class 130.—*Pen of Three Southdown Ram Lambs, dropped in 1891.* [14 entries, 5 absent.]

- 1760 I. (£10).—H.R.H. THE PRINCE OF WALES, K.G., Sandringham, born Mar.  
 1769 II. (£5).—C. T. LUCAS, Warnham Court, Horsham, born Feb. 14.  
 1765 R. N. & H. C.—EDWIN ELLIS, Summersbury, Shalford, Guildford.  
 H. C.—J. J. COLMAN, M.P., for No. 1763; WM. TOOP for No. 1773.

### Class 131.—*Pen of Three Southdown Shearling Ewes, of the same flock.* [20 entries, 6 absent.]

- 1783 I. (£15).—THE DUKE OF HAMILTON AND BRANDON, K.T., Easton Park, Wickham Market, born Feb. 24, 1890.  
 1778 II. (£10).—J. J. COLMAN, M.P., Carrow Ho., Norwich, born Feb. 1890.  
 1793 III. (£5).—WM. TOOP, Aldingbourne, Chichester, born Feb. 7, 1890.  
 1780 R. N. & H. C.—A. DE MURRIETA, Wadhurst Park, Sussex, born Feb.  
 H. C.—H.R.H. THE PRINCE OF WALES, K.G., for Nos. 1774 & 1775;  
 JAMES BLYTH for No. 1776; A. DE MURRIETA for No. 1779; EDWIN ELLIS for No. 1781; A. HEASMAN for No. 1784; GEORGE JONAS for No. 1787; C. T. LUCAS for No. 1788; THE DUKE OF RICHMOND AND GORDON, K.G., for No. 1791; SIR WM. THROCKMORTON, Bt., for No. 1792.

## Hampshire Downs.

### Class 132.—*Hampshire Down Two-Shear Rams.* [7 entries, none absent.]

- 1795 I. (£15).—R. COLES, Boreham, Warminster, for **Little Wonder**, born Jan.  
 1799 II. (£10).—FRANK R. MOORE, Littlecott, Upavon, Marlborough, for **Alton**, born Jan. 1889.  
 1796 III. (£5).—ROBERT COLES, for **Victor III.**, born Jan. 1889.  
 1798 R. N. & H. C.—H. LAMBERT, Babraham, Cambridge, for **Prize-fighter**.  
 Com.—T. FOWELL BUXTON for No. 1794, **Little Hero**; J. EAST for No. 1797; F. R. MOORE for No. 1800.

[Unless otherwise stated, each prize animal named below was "bred by exhibitor."]

**Class 133.**—*Hampshire Down Shearling Rams.* [18 entries, 2 absent.]

- 1801 **I.** (£15.)—JOHN BARTON, Hackwood Farm, Basingstoke, born Jan. 1890.  
 1810 **II.** (£10.)—HENRY LAMBERT, Babraham, Cambridge, born Jan. 1890.  
 1807 **III.** (£5.)—ROBERT COLES, Boreham, Warminster, for **Middleton**, born Feb. 1890; s. Victor II. 35.  
 1813 **R. N. & H. C.**—H. LE ROY LEWIS, Westbury Park, Petersfield, born Jan. 1890.  
**H. C.**—ROBERT COLES for No. 1808; WM. NEWTON for No. 1816.  
**Com.**—T. FOWELL BUXTON for No. 1802, **Young Hero**; ROBERT COLES for No. 1806, **Victor IV.**; HENRY LAMBERT for No. 1811; WM. NEWTON for No. 1817, **Baron Huddleston.**

**Class 134.**—*Pen of Three Hampshire Down Ram Lambs, dropped in 1891.* [16 entries, 3 absent.]

- 1826 **I.** (£10.)—HENRY LAMBERT, Babraham, Cambridge, born Jan. 1891.  
 1819 **II.** (£5.)—JOHN BARTON, Hackwood Farm, Basingstoke, born Jan. 1890.  
 1830 **R. N. & H. C.**—WM. NEWTON, Crowmarsh Battle, Wallingford, born Jan. 1890.  
**H. C.**—T. FOWELL BUXTON for Nos. 1820 & 1821; F. R. MOORE for Nos. 1828 & 1829.  
**Com.**—JOSHUA EAST for No. 1825; E. WHALLEY-TOOKER for No. 1833.

**Class 135.**—*Pen of Three Hampshire Down Shearling Ewes, of the same flock.* [9 entries, 2 absent.]

- 1841 **I.** (£15.)—WM. NEWTON, Crowmarsh Battle, Wallingford, born Jan. 1890.  
 1837 **II.** (£10.)—J. EAST, Longstock House, Stockbridge, born Jan. 1890.  
 1840 **III.** (£5.)—WM. NEWTON, born Jan. 1890.  
 1838 **R. N. & H. C.**—F. R. MOORE. **H. C.**—C. & T. COLES for No. 1835.  
**Com.**—A. M. ROBINSON for No. 1842; E. WHALLEY-TOOKER for No. 1843.

## Suffolks.

**Class 136.**—*Suffolk Two-Shear Rams.* [7 entries, 1 absent.]

- 1846 **I.** (£15.)—THE MARQUIS OF BRISTOL, Ickworth Park, Suffolk, for **Duke of Tuddenham III.** 961, born Feb. 10; s. Duke of Tuddenham II. 647.  
 1848 **II.** (£10.)—T. L. ROBERSON & W. GOUGH, Hengrave, Suffolk, for **The Friar** 1148, born Feb., bred by E. Gittus, Snailwell; s. Quite Royal 759.  
 1845 **III.** (£5.)—THE MARQUIS OF BRISTOL, for **Van Dyke V.** 1159, born Jan. 22, 1889; s. Van Dyke II. 539.  
 1844 **R. N. & H. C.**—THE MARQUIS OF BRISTOL, for **Van Gwynne Royal IV.**  
**Com.**—EDWARD GITTUS for No. 1847, **Sailor**; J. SMITH for No. 1849.

**Class 137.**—*Suffolk Shearling Rams.* [9 entries, none absent.]

- 1854 **I.** (£15.)—EDWARD GITTUS, Snailwell, Cambs, for **Sailor II.**, born Feb. 1890; s. Sailor 1112, d. by Bismark V.  
 1851 **II.** (£10.)—THE MARQUIS OF BRISTOL, Ickworth Park, Suffolk, for **Van Gwynne Royal VI.** 1644, born Jan. 10; s. Van Gwynne Royal III. 1163.  
 1857 **III.** (£5.)—T. L. ROBERSON & W. GOUGH, Hengrave, Suffolk, for **Moulton**, born Feb., bred by H. Northend, Moulton; s. Don Carlos 956.  
 1855 **R. N. & H. C.**—EDWARD GITTUS, for **Quite Royal II.**, born Feb. 1890.  
**Com.**—THE MARQUIS OF BRISTOL for No. 1852, **Van Gwynne Royal VII.**, and No. 1853, **Van Dyke VII.**; T. L. ROBERSON & W. GOUGH for No. 1856, **King of the Black Face**; JOSEPH SMITH for No. 1858.

[Unless otherwise stated, each prize animal named below was "bred by exhibitor."]

**Class 138.**—*Pen of Three Suffolk Ram Lambs, dropped in 1891.*  
[8 entries, 2 absent.]

- 1861 **I.** (£10.)—THE MARQUIS OF BRISTOL, Ickworth Park, Suffolk, born Jan.  
1863 **II.** (£5.)—EDWARD GITTUS, Snailwell, Cambs, born Feb.  
1864 **R. N. & H. C.**—T. L. ROBERSON & W. GOUGH, Hengrave, Suffolk.  
1865 **H. C.**—JOSEPH SMITH, Thorpe Hall, Hasketon, Woodbridge, born Feb.  
1866 **Com.**—JOSEPH SMITH, born Feb.

**Class 139.**—*Pen of Three Suffolk Shearling Ewes, of the same flock.*  
[8 entries, 1 absent.]

- 1874 **I.** (£15.)—J. SMITH, Thorpe Hall, Hasketon, Woodbridge, born Feb. 1890.  
1873 **II.** (£10.)—T. L. ROBERSON & W. GOUGH, Hengrave, Suffolk, born Feb., bred by Roberson & Eaton, Hengrave; *s.* Hengrave Pride 690.  
1868 **III.** (£5.)—THE MARQUIS OF BRISTOL, Ickworth Park, born Jan. 1890.  
1871 **R. N. & H. C.**—EDWARD GITTUS, born February, 1890; *s.* Sailor Prince.  
**Com.**—THE MARQUIS OF BRISTOL for No. 1869; T. L. ROBERSON & W. GOUGH for No. 1872; JOSEPH SMITH for No. 1875.

## Wensleydales.

**Class 140.**—*Wensleydale Two-Shear Rams.* [8 entries, 1 absent.]

- 1881 **I.** (£15.)—J. O. TROTTER, Holtby Grange, Bedale, for **Champion 122**, born Apr. 1, 1889; *s.* Abelard 3, *d.* by Ridley.  
1877 **II.** (£10.)—JOHN HEUGH, Mudd Fields, Bedale, for **Thumper**, born abt. Mar. 20, bred by Miss E. Willis, Carperby, Bedale; *s.* Sir Thorsby.  
1876 **III.** (£5.)—F. HEUGH, Newton-le-Willows, Bedale, for **Ruffler IV.** 191, born Mar., bred by J. Pickard, Thorsby, Bedale; *s.* Lord of the Manor 54.  
1883 **R. N. & H. C.**—T. WILLIS, Carperby, Bedale, for **Lord of the Valley.**  
1879 **Com.**—MAJOR JOHN I'ANSON, How Hall, Thirsk, for **Sheen 192.**

**Class 141.**—*Wensleydale Shearling Rams.* [18 entries, 3 absent.]

- 1887 **I.** (£15.)—JOHN HEUGH, Mudd Fields, Bedale, born about Mar. 6, 1890, bred by W. Heugh, Newton-le-Willows; *s.* Thorsby III. 91 *d.* by Thorsby I.  
1889 **II.** (£10.)—JOHN HEUGH, for **Number 2**, born about Mar. 8, 1890; *s.* Number 1, *d.* by Thorsby I.  
1897 **III.** (£5.)—JOHN O. TROTTER, Holtby Grange, Bedale, born Mar. 30, 1890; *s.* Masham I. 57, *d.* by Ridley.  
1886 **R. N. & H. C.**—F. HEUGH, Newton-le-Willows, Bedale, for **Ruffler.**  
1898 **Com.**—JOHN O. TROTTER, Holtby Grange, Bedale.

**Class 142.**—*Pen of Three Wensleydale Ram Lambs, dropped in 1891.*  
[8 entries, 1 absent.]

- 1904 **I.** (£10.)—JOHN HEUGH, Mudd Fields, Bedale, born March; *s.* Datchet 30, *d.* by Thorsby I.  
1906 **II.** (£5.)—A. TROTTER, Dantzic House, Bedale, born Apr.; *s.* Dantzic 28.  
1909 **R. N. & H. C.**—THOMAS WILLIS, Carperby, Bedale, born Apr.; *ss.* Lord of the Valley, Titan 74, & Sir Wilfred 63, *dd.* by Westward Ho 79, Thor's Hammer 73, Thorsby 72.  
1908 **Com.**—J. O. TROTTER, Holtby Grange, Yorks; *ss.* Sitting Bull & Abelard.

[Unless otherwise stated, each prize animal named below was "bred by exhibitor."]

**Class 143.**—*Pen of Three Wensleydale Shearling Ewes, of the same flock.* [7 entries, none absent.]

- 1911 I. (£15.)—JOHN HEUGH, Mudd Fields, Bedale, born about Mar. 10, 1890; s. Number 1 63.  
 1912 II. (£10.)—JOHN HEUGH, born about Mar. 10, 1890; s. Thorsby III. 91, d. by Thorsby I.  
 1914 III. (£5.)—WM. RHODES, Lundholme, Westhouse, Kirkby Lonsdale, born about Mar. 11, 1890; s. Sterling 69 or Swinethwaite 71.  
 1915 B. N. & H. C.—THOMAS WILLIS, Carperby, Bedale, born Mar. & Apr.

### Border Leicesters.

**Class 144.**—*Border Leicester Rams, Two-Shear and Upwards.*  
 [9 entries, 1 absent.]

- 1917 I. (£10.)—THE RT. HON. A. J. BALFOUR, M.P., Whittinghame, Prestonkirk, N.B., born Mar. 1889.  
 1922 II. (£5.)—EXORS. OF ROBERT FENDER, Northfield, Coldingham, Berwick, born Feb. 3, 1887.  
 1918 B. N. & H. C.—THE RT. HON. A. J. BALFOUR, M.P., born Mar. 1889.  
 1919 Com.—DAVID COOPER, Bainses, Catterick, born Mar. 1889.

**Class 145.**—*Border Leicester Shearling Rams.*  
 [14 entries, 2 absent.]

- 1926 I. (£10.)—THE RT. HON. A. J. BALFOUR, M.P., Whittinghame, Prestonkirk, N.B., born Mar. 1890.  
 1929 II. (£5.)—EXORS. OF ROBERT FENDER, Northfield, Coldingham, Berwick, born Mar. 3, 1890.  
 1936 B. N. & H. C.—J. TWENTYMAN, Hawkrigg House, Wigton, born Mar.  
 1930 Com.—EXORS. OF ROBERT FENDER, born Mar. 6, 1890.

**Class 146.**—*Pen of Three Border Leicester Shearling Ewes, of the same flock.* [7 entries, 2 absent.]

- 1940 I. (£10.) and 1941 II. (£5.)—THE RT. HON. A. J. BALFOUR, M.P., Whittinghame, Prestonkirk, N.B., born Mar. 1890.  
 1942 B. N. & H. C.—EXORS. OF ROBERT FENDER, Northfield, Coldingham.  
 1944 Com.—JOHN TWENTYMAN, Hawkrigg House, Wigton, born Mar. 1890.

### Cheviots.

**Class 147.**—*Cheviot Rams, Two-Shear and Upwards.*  
 [6 entries, none absent.]

- 1949 I. (£10.)—JACOB ROBSON, Byrness, Otterburn, born Apr. 1889.  
 1952 II. (£5.)—JOHN ROBSON, Newton, Bellingham, born Apr. 1889.  
 1947 B. N. & H. C.—JACOB ROBSON, born Apr. 1888.  
 1950 Com.—JOHN ROBSON, born Apr. 1888.

[Unless otherwise stated, each prize animal named below was "bred by exhibitor."]

**Class 148.**—*Cheviot Shearling Rams.* [6 entries, none absent.]

- 1956 I. (£10.)—JOHN ROBSON, Newton, Bellingham, born Apr. 1890.  
 1953 II. (£5.)—JACOB ROBSON, Byrness, Otterburn, born Apr. 1890.  
 1954 R. N. & H. C.—JACOB ROBSON, born Apr. 1890.

**Class 149.**—*Pen of Three Cheviot Shearling Ewes, of the same flock.*  
 [4 entries, none absent.]

- 1961 I. (£10.)—JOHN ROBSON, Newton, Bellingham, born Apr. 1890.  
 1959 II. (£5.)—JACOB ROBSON, Byrness, Otterburn, born Apr. 1890.  
 1962 R. N. & H. C.—JOHN ROBSON, born Apr. 1890.

### Black-Faced Mountain.

**Class 150.**—*Black-Faced Mountain Rams, Two-Shear and Upwards.*  
 [9 entries, 2 absent.]

- 1963 I. (£10.)—J. ARCHIBALD, Overshiels, Fountainhall, N.B., born Apr. 1888.  
 1966 II. (£5.)—W. MCCRACKEN, Greenleighton, Cambo, for Prince III., born Apr. 10, 1889; s. Prince II.  
 1964 R. N. & H. C.—J. ARCHIBALD, born Apr. 1888.

**Class 151.**—*Black-Faced Mountain Shearling Rams.*  
 [9 entries, 2 absent.]

- 1980 I. (£10.)—R. S. SCOTT, Craigievar, Skelmorlie, N.B., born Mar.; s. Sixty-eight.  
 1974 II. (£5.)—W. MCCRACKEN, Greenleighton, Cambo, born Apr. 2, 1890.  
 1976 R. N. & H. C.—R. RAWLINSON, Docker Hall, Kendal, born Apr. 15.

**Class 152.**—*Pen of Three Black-Faced Mountain Shearling Ewes, of the same flock.* [8 entries, none absent.]

- 1984 I. (£10.)—D. T. MARTIN, Girgenti, Irvine, N.B., born Apr. 1890.  
 1986 II. (£5.)—R. RAWLINSON, Docker Hall, Kendal, born Apr. 1890.  
 1982 R. N. & H. C.—WM. GRAHAM, Eden Grove, Penrith, born Mar. 1890.

### Lonks.

**Class 153.**—*Lonk Rams, Two-Shear and Upwards.* [2 entries.]

- 1990 I. (£10.)—WALTON BROTHERS, Rawtenstall, Lancs, born Mar. 1888, bred by T. Hargreaves, Rawtenstall.  
 1989 II. (£5.)—JOSEPH BLACKBURN, Holling Hall, Trawden, for The Pride of Trawden, born Mar. 15, 1889; d. by Old Champion Peggy.

**Class 154.**—*Lonk Shearling Rams.* [2 entries.]

- 1991 I. (£10.)—WALTON BROTHERS, Rawtenstall, Lancs, born Mar. 1890, bred by Joseph Blackburn, Trawden.  
 1992 II. (£5.)—WALTON BROTHERS, born Mar. 1890.

[Unless otherwise stated, each prize animal named below was "bred by exhibitor."]

**Class 155.**—*Pen of Three Lonk Shearling Ewes, of the same flock.*  
[3 entries.]

- 1994 **I.** (£10.)—WALTON BROTHERS, Rawtenstall, Lancs, born Mar. 1890, bred by various breeders.  
1993 **II.** (£5.)—MRS. W. C. DAWSON, Weston Hall, Otley, born Mar. 14 ;  
*s.* Jumbo.  
1995 **R. N. & H. C.**—WALTON BROTHERS, born Mar. 1890.

## Herdwicks.

**Class 156.**—*Herdwick Rams, Two-Shear and Upwards.*  
[9 entries, 1 absent.]

- 1996 **I.** (£10.)—WM. ABBOTT, Hart Head, Rydal, Ambleside, for **Prince Victor**, born Apr. 1889, bred by H. C. Howard, Greystoke, Penrith.  
1999 **II.** (£5.)—JAMES C. BOWSTEAD, Chapel Hill, Mardale, Penrith, for **Aries**, born in Apr. 1888, bred by the representatives of the late Hugh P. Holme ;  
*s.* Ruffler, *d.* Hailstorm *by* Gladstone.  
2002 **R. N. & H. C.**—JOHN ROTHERY, Lorton, Cockermouth, for **Prime Minister**.

**Class 157.**—*Herdwick Shearling Rams.* [8 entries, 1 absent.]

- 2008 **I.** (£10.)—JAMES C. BOWSTEAD, Chapel Hill, Mardale, Penrith, for **Harterfell**, born Apr. 1890, bred by late Mrs. J. C. Bowstead ; *s.* Scawfell, *d.* Princess Maude *by* Ruffler.  
2009 **II.** (£5.)—H. C. HOWARD, Greystoke Castle, Penrith, for **Cain**, born Mar. 16.  
2005 **R. N. & H. C.**—W. ABBOTT, Hart Head, Rydal, for **Duke of Cumberland**.  
2010 **H. C.**—HENRY C. HOWARD, born April, 1890.

**Class 158.**—*Pen of Three Herdwick Shearling Ewes, of the same flock.*  
[5 entries, none absent.]

- 2013 **I.** (£10.)—WM. ABBOTT, Hart Head, Rydal, Ambleside, born Apr. 1890, bred by Exhibitor & John Rothery, Lorton.  
2015 **II.** (£5.)—HENRY C. HOWARD, Greystoke Castle, Penrith, born Apr.  
2014 **R. N. & H. C.**—J. C. BOWSTEAD, for **Molly Dearest**, **Molly Sweetest**, &  
**(Molly Fairest.)**

## PIGS.

### Large White Breed.

**Class 159.**—*Large White Boars, farrowed in 1890.*  
[7 entries, 1 absent.]

- 2024 **I.** (£10.)—SANDERS SPENCER, Holywell Manor, St. Ives, Hunts, for **Holywell Bath**, born Jan. 1 ; *s.* Holywell Jackie 989, *d.* Holywell Jewel 2324 *by* Holywell King 509.  
2018 **II.** (£5.)—ISAAC BEARDSLEY, Handley Farm, Shottle, Belper, for **Sampson IV.**, born Jan. 13 ; *s.* Jarvo, *d.* Silver Queen.  
2021 **III.** (£3.)—THE GUARDIANS OF PRESCOT UNION, for **Prescot VIII.**, born Feb. 21 ; *s.* Prescot III. 1381, *d.* Whiston II. 1864.  
2023 **R. N.**—SANDERS SPENCER, for **Holywell Doncaster**, born Jan. 1.

[Unless otherwise stated, each prize animal named below was "bred by exhibitor."]

**Class 160.**—*Pen of Three Large White Boar Pigs, farrowed in 1891.*  
[8 entries, 1 absent.]

- 2029 **I.** (£10.)—JOSEPH NUTTALL, 19, Longfield, Heywood, born Jan. 8, 1891; s. Ben III. 927, d. Sarah.  
2028 **II.** (£5.)—D. R. DAYBELL, Bottesford, Nottingham, born Jan. 1, 1891; s. Cestrian Rover, d. Bottesford Lass VI.  
2026 **R. N.**—RICHARD BODDINGTON, Colebrook Hall, Shirley, Birmingham.

**Class 161.**—*Large White Breeding Sows, farrowed before or in 1890.*  
[10 entries, 5 absent.]

- 2035 **I.** (£10.)—HON. MRS. MEYNELL INGRAM, Temple Newsam, Leeds, born Apr. 23, 1888.  
2034 **II.** (£5.)—HON. MRS. MEYNELL INGRAM, born Nov. 10, 1888, bred by Thos. Strickland, Thirsk Junction.  
2033 **III.** (£3.)—A. E. DYSON, The Hollies, Timperley, Cheshire, for **Cestrian Giantess**, born Nov. 6, 1888, bred by F. A. Walker-Jones, Mollington, Cheshire; s. Madman III. 745, d. Miss Hough II. 1270.  
2040 **R. N. & H. C.**—SANDERS SPENCER, for **Holywell Virago II.** 2348.  
2039 **Com.**—SANDERS SPENCER, for **Holywell Shrimp X.**

**Class 162.**—*Pen of Three Large White Sow Pigs, farrowed in 1891.*  
[8 entries, 1 absent.]

- 2048 **I.** (£10.)—SANDERS SPENCER, Holywell Manor, St. Ives, Hunts, born Jan. 3; s. Holywell Plymouth (vol. vii.), d. Holywell Squeak by Holywell Dairyman II. 1305.  
2047 **II.** (£5.)—THE GUARDIANS OF PRESCOT UNION, born Jan. 4; s. Prescott VI. 1387, d. Whiston V. 2624.  
2044 **III.** (£3.)—RICHARD BODDINGTON, Colebrook Hall, Shirley, Birmingham born Jan. 2; s. Colebrook King (vol. vii.), d. Colebrook Lass (vol. vii.) by Walsall Jack.  
2050 **R. N. & H. C.**—SANDERS SPENCER, for **Holywell Valentine I. II. and III.**

### Middle White Breed.

**Class 163.**—*Middle White Boars, farrowed in 1890.*  
[4 entries, 1 absent.]

- 2053 **I.** (£10.)—SANDERS SPENCER, Holywell Manor, St. Ives, Hunts, for **Holywell Count**, born June 20; s. German Baron 825, d. Straight Locks 2684 by Holywell Swell 591.  
2052 **R. N.**—JOSEPH NUTTALL, Heywood, born Jan. 16; s. Hero, d. Snowdrop.

**Class 164.**—*Pen of Three Middle White Boar Pigs, farrowed in 1891.*  
[5 entries, none absent.]

- 2059 **I.** (£10.)—SANDERS SPENCER, Holywell Manor, St. Ives, Hunts, born Jan. 14; s. Holywell Slasher (vol. vii.), d. Holywell Rose 2682 by Holywell Swell 591.  
2058 **II.** (£5.)—SANDERS SPENCER, born Jan. 14; s. Holywell Slasher (vol. vii.), d. Holywell Rose 2682 by Holywell Swell 591.  
2057 **R. N.**—SANDERS SPENCER, born Jan. 4; s. German Baron 825.



[Unless otherwise stated, each prize animal named below was "bred by exhibitor."]

**Class 165.**—*Middle White Breeding Sows, farrowed before or in 1890.*  
[10 entries, 4 absent.]

- 2065 **I.** (£10.)—JOSEPH NUTTALL, 19 Longfield, Heywood, born Jan. 6, 1888; *s.* Billy, *d.* Lancashire Sall.  
2068 **II.** (£5.)—SANDERS SPENCER, Holywell Manor, St. Ives, Hunts, for **Holywell Rose** 2682, born Mar. 7, 1888; *s.* Holywell Swell 591, *d.* Holywell Duchess 882 *by* No. 1 181.  
2060 **III.** (£3.)—A. E. DYSON, The Hollies, Timperley, Cheshire, for **Cestrian Princess**, abt. 3 years old, bred by the Earl of Ellesmere; *s.* King William, *d.* Lady Worsley.  
2067 **B. N. & H. C.**—SANDERS SPENCER, for **Holywell Bissole**.

**Class 166.**—*Pen of Three Middle White Sow Pigs, farrowed in 1891.*  
[7 entries, 1 absent.]

- 2070 **I.** (£10.)—C. E. DUCKERING, The Cliff, Kirton Lindsey, born Jan. 3.  
2076 **II.** (£5.)—SANDERS SPENCER, Holywell Manor, St. Ives, Hunts, born Jan. 4; *s.* German Baron 825, *d.* Holywell Choice 1380 *by* Holywell Swell.  
2074 **B. N. & Com.**—THE GUARDIANS OF PRESCOT UNION, born Jan. 3.

### Small White Breed.

**Class 167.**—*Small White Boars, farrowed in 1890.*  
[4 entries, none absent.]

- 2077 **I.** (£10.)—THE HON. D. P. BOUVERIE, Coleshill House, Highworth, born May 9, bred by Lord Moreton; *s.* Earl of Chester, *d.* Spot II. *by* Rodney.  
2079 **II.** (£5.)—J. & T. OLDROYD, Newsam Green, Leeds, born July 12; *s.* Uncle Tom II., *d.* *by* Lister's Hero.  
2080 **B. N. & H. C.**—THE COUNTESS OF RADNOR, Longford Castle, for **The General**.

**Class 168.**—*Pen of Three Small White Boar Pigs, farrowed in 1891.*  
[4 entries, 1 absent.]

- 2083 **I.** (£10.)—THE HON. D. P. BOUVERIE, Coleshill House, Highworth, born Jan. 2; *s.* King William, *d.* Shaftesbury *by* Prince.  
2083 **II.** (£5.)—THE HON. D. P. BOUVERIE, born Jan. 3; *s.* King William, *d.* Spot III. *by* Prince.  
2081 **B. N.**—W. A. TYSSEN AMHERST, M.P., born Jan. 20; *s.* Gilbert, *d.* Bertha 2732.

**Class 169.**—*Small White Breeding Sows, farrowed before or in 1890.*  
[9 entries, none absent.]

- 2089 **I.** (£10.)—HON. MRS. MEYNELL INGRAM, Temple Newsam, Leeds, born May 10, 1889.  
2088 **II.** (£5.)—HON. MRS. MEYNELL INGRAM, born May 10, 1889.  
2087 **III.** (£3.)—HON. D. P. BOUVERIE, Coleshill House, Highworth, born May 14, 1890; *s.* Coleshill Farmer, *d.* Susan *by* Prince.  
2092 **B. N. & H. C.**—THE COUNTESS OF RADNOR, for **Longford Beauty**.  
2091 **H. C.**—THE GUARDIANS OF PRESCOT UNION, for **Whiston Toy**.  
**Com.**—WM. A. TYSSEN AMHERST, M.P., for No. 2085, **Brilliant**; J. NUTTALL for No. 2090, **Clara**.

[Unless otherwise stated, each prize animal named below was "bred by exhibitor."]

**Class 170.**—*Pen of Three Small White Sow Pigs, farrowed in 1891.*  
[3 entries, 1 absent.]

2096 **I.** (£10.)—THE GUARDIANS OF PRESCOT UNION, born Jan. 6, bred by Oldroyd Bros., Newsam Green, Yorks: *s.* Uncle Tom II. *by* Uncle Tom 251, *d.* *by* Hero III. 631.

2095 **R. N. & Com.**—HON. D. P. BOUVERIE, born Jan. 3: *s.* King William.

### Berkshire Breed.

**Class 171.**—*Berkshire Boars, farrowed in 1890.* [16 entries, 5 absent.]

2103 **I.** (£10 & **R. N.** for **Champion**.)—E. BURRIDGE, South Wraxhall, Bradford, Wilts, born Mar. 13: *s.* Ransome 2675, *d.* Mary Jane.

2111 **II.** (£5.)—WM. PINNOCK, Littleworth House, Wantage, for **Farmer's Friend**, born Feb. 24: *s.* Longstop 2819, *d.* Taynton IV. 1218.

2105 **III.** (£3.)—SIR HUMPHREY F. DE TRAFFORD, Bart., Trafford Park, Lancs, for **Barton Royal**, born Feb. 14, bred by Wm. Pinnock; *s.* Longstop, *d.* Taynton Poetess 2384.

2099 **R. N.**—NATHANIEL BENJAMFIELD, for **Commander**, born Mar. 27.

**Class 172.**—*Pen of Three Berkshire Boar Pigs, farrowed in 1891.*  
[7 entries, 1 absent.]

2117 **I.** (£10.)—SIR HUMPHREY F. DE TRAFFORD, Bart., Trafford Park, Lancs., born Jan. 14; *s.* Barton Royal, *d.* Barton Kate.

2116 **II.** (£5.)—A. E. W. DARBY, Little Ness, Shrewsbury, born Jan. 27; *s.* Sir Andrew, *dd.* Parthenon and Punchetta.

2115 **III.** (£3.)—A. E. W. DARBY, born Jan. 27; *s.* Sir Andrew II., *d.* Parthenon.

2113 **R. N.**—NATHANIEL BENJAMFIELD, born Jan. 27; *s.* Blunt II. 2315.

**Class 173.**—*Berkshire Breeding Sows, farrowed before or in 1890.*  
[22 entries, none absent.]

2123 **I.** (£10 & **Champion** £10.)—NATHANIEL BENJAMFIELD, Shorts Green Farm, Motcombe, Dorset, for **Her Majesty**, born Dec. 3, 1889; *s.* Mayduke 1251, *d.* Mayoress 1411.

2121 **II.** (£5.)—WM. A. BARNES, Mona Cottage, Shirley, Birmingham, for **Rosalind Augustus II.** 3258, born Jan. 8, 1890; *s.* Western Augustus 2856, *d.* Rosalind Augustus 2074.

2140 **III.** (£3.)—WM. PINNOCK, Littleworth House, Wantage, for **Belle of Wantage**, born Feb. 24, 1890; *s.* Longstop 2819, *d.* Taynton IV. 1218.

2137 **R. N. & H. C.**—J. W. KIMBER, Fyfield Wick, Abingdon.

**H. C.**—A. E. W. DARBY for No. 2128, **Phlox**; A. S. GIBSON for No. 2133, **Conny II.**

**Com.**—EDWARD BURRIDGE for No. 2126, **Freedom**; A. E. W. DARBY for No. 2129, **Polyanthus**; A. E. DYSON for No. 2131, **Cestrian Lady**; H. P. GREEN for No. 2134, **Virginia II.**

**Class 174.**—*Pen of Three Berkshire Sow Pigs, farrowed in 1891.*  
[10 entries, 1 absent.]

2148 **I.** (£10.)—R. E. HORWOOD, Drayton Beauchamp, Tring, born Jan. 10; *s.* Benjafield 2556, *d.* Terriek Lady 2555.

2146 **II.** (£5.)—SIR HUMPHREY F. DE TRAFFORD, Bart., Trafford Park, Lancs., born Jan. 14; *s.* Barton Royal, *d.* Lancashire Queen.

<sup>1</sup> Given by the British Berkshire Society for the best animal exhibited in classes 171 and 173.

[Unless otherwise stated, each prize animal named below was "bred by exhibitor."]

- 2144 **III.** (£3).—A. E. W. DABBY, Little Ness, Shrewsbury, born Jan. 27 & 31; *s.* Sir Andrew II, *d.* Parthenon and Punchetta.  
 2150 **B. N. & H. C.**—T. S. MINTON, Montford Bridge, born Jan. 16 & 19.

### Any Other Black Breed.

**Class 175.**—*Boars, farrowed in 1890.* [3 entries.]

- 2153 **I.** (£10).—THE DUKE OF HAMILTON & BRANDON, K.T., Easton Park, Wickham Market, for **Common**, born Feb. 18; *s.* Dartmoor, *d.* Countess 610.  
 2152 **II.** (£5).—THE DUKE OF HAMILTON AND BRANDON, K.T., for **Parson**, born Apr. 30; *s.* Dartmoor 913, *d.* Topsy.  
 2154 **B. N. & H. C.**—GEORGE PETTIT, Friston, Saxmundham, for **Doncaster**.

**Class 176.**—*Pen of Three Boar Pigs, farrowed in 1891.* [3 entries.]

- 2156 **I.** (£10).—GEORGE PETTIT, The Firs, Friston, Saxmundham, born Jan. 7; *s.* Duke 1195, *d.* Primrose 2124.  
 2157 **II.** (£5).—GEORGE PETTIT, born Jan. 25; *s.* Danger, *d.* Rose.  
 2155 **B. N. & H. C.**—THE DUKE OF HAMILTON AND BRANDON, K.T.

**Class 177.**—*Breeding Sows, farrowed before or in 1890.*  
 [3 entries, 1 absent.]

- 2160 **I.** (£10).—GEORGE PETTIT, The Firs, Friston, Saxmundham, born Jan. 24, 1890; *s.* Duke, *d.* Patty.  
 2159 **II.** (£5).—THE DUKE OF HAMILTON & BRANDON, K.T., Easton Park, Wickham Market, for **Chance**, b. Sept. 1, 1888; *s.* Tommy 455, *d.* Princess 618.

**Class 178.**—*Pen of Three Sow Pigs, farrowed in 1891.*  
 [4 entries, 1 absent.]

- 2163 **I.** (£10).—GEORGE PETTIT, The Firs, Friston, Saxmundham, born Jan. 7; *s.* Duke 1195, *d.* Primrose 2124.  
 2164 **II.** (£5).—GEORGE PETTIT, born Jan. 25; *s.* Danger, *d.* Rose.  
 2162 **B. N. & H. C.**—THE DUKE OF HAMILTON & BRANDON, K.T., born Jan. 30.

### Tamworth Breed.

**Class 179.**—*Tamworth Boars, farrowed in 1890.*  
 [10 entries, 2 absent.]

- 2166 **I.** (£10).—R. BODDINGTON, Colebrook Hall, Shirley, Birmingham, for **Colebrook Squire** (vol. vii.), born June 23; *s.* Earl Winterton 1583, *d.* Whitacre Princess 2936.  
 2170 **II.** (£5).—J. H. JORDAN, Clifford Hill, Stratford-on-Avon, born May 24; *s.* Royal Winner, *d.* Clifford Red Rose.  
 2171 **III.** (£3).—WM. H. MITCHELL, Elmdene, Kenilworth, for **Elmdene King**, born June 6; *s.* Samson III. 1639, *d.* Nana.  
 2169 **B. N. & H. C.**—J. H. JORDAN, born May 14; *s.* Wallace II.

**Class 180.**—*Pen of Three Tamworth Boar Pigs, farrowed in 1891.*  
 [8 entries, 1 absent.]

- 2182 **I.** (£10).—THOMAS TOMPSON, Holt Hall, Whitacre, Birmingham, born Jan. 5; *s.* Uncle John (vol. vii.), *d.* Ma'spring III. (vol. vii.).

[Unless otherwise stated, each prize animal named below was "bred by exhibitor."]

- 2179 **II.** (£5).—JOHN NORMAN, JUN., Cliff House, Tamworth, and JOSEPH NORMAN, Nether Whitacre, Coleshill, born Jan. 25; s. Tomato 1659, d. Red Rose 2066.
- 2181 **III.** (£3).—D. W. PHILIP, The Ashes, Whitacre, Coleshill, born Jan. 3; s. Noah, d. Dorridge Rosa 2790.
- 2180 **R. N.**—JOHN NORMAN, JUN., and JOSEPH NORMAN, born Feb. 2.

**Class 181.**—*Tamworth Breeding Sows, farrowed before or in 1890.*  
[26 entries, 2 absent.]

- 2198 **I.** (£10).—JOHN NORMAN, JUN., Tamworth, and JOSEPH NORMAN, Nether Whitacre, Coleshill, for **Plymouth Heroine**, born Jan. 2, 1890; s. The Swell 1657, d. Sally 564.
- 2187 **II.** (£5).—R. BODDINGTON, Colebrook Hall, Shirley, Birmingham, for **Colebrook Belle**, born Jan. 2, 1890; s. Shirley II. 1645, d. Whitacre Queen, 2938.
- 2197 **III.** (£3).—JOHN NORMAN, JUN., and JOSEPH NORMAN, for **Cliff Beauty**, born Nov. 5, 1889; s. Tomboy 1185, d. Nottingham Heroine 2048.
- 2196 **R. N. & H. C.**—W. H. MITCHELL, for **Elmdene Queen**.  
**H. C.**—R. IBBOTSON for No. 2193, **Knowle Queen**; W. H. MITCHELL for No. 2195, **Elmdene Princess**; G. T. WHITFIELD for No. 2206, **Colebridge Belle**.  
**Com.**—LORD AUCKLAND for No. 2184; D. W. PHILIP for No. 2199, **Grand Duchess**; THOMAS WATSON for No. 2205, **Whitacre Queen IV.**

**Class 182.**—*Pen of Three Tamworth Sow Pigs, farrowed in 1891.*  
[13 entries, 3 absent.]

- 2213 **I.** (£10).—ROBERT IBBOTSON, Knowle, Warwickshire, born Jan. 2; s. Royal George, d. Dorridge Duchess.
- 2218 **II.** (£5).—D. W. PHILIP, The Ashes, Whitacre, Coleshill, born Jan. 4; s. Noah, d. Dorridge Ruby 2794.
- 2211 **III.** (£3).—EGBERT DE HAMEL, Middleton Hall, Tamworth, born Jan. 9; s. Middleton Masher 2189, d. Middleton Madcap 2864.
- 2221 **R. N. & H. C.**—THOMAS TOMPSON, Holt Hall, Whitacre, Coleshill.
- 2216 **H. C.**—JOHN NORMAN, JUN., and JOSEPH NORMAN, born Jan. 11.
- 2214 **Com.**—ROBERT IBBOTSON, born Feb. 12.

## POULTRY.

By "Cock," "Hen," "Drake," "Duck," "Gander," and "Goose" are meant birds hatched before January 1st, 1891; and by "Cockerel," "Pullet," "Young Drake," and "Duckling," are meant birds hatched in 1891, before June 1st.

### FOWLS.

#### Dorkings.

**Class 183.**—*Coloured Dorking Cocks.* [8 entries, none absent.]

- 6 **I.** (£2).—WM. S. PINSENT, Rose Hall, Newton Abbot.
- 1 **II.** (£1).—JAMES CRANSTON, Tinwald House, Dumfries, N.B. 1890.
- 3 **III.** (10s.).—THOMAS HULSE, Bank Quay, Middlewich, Cheshire. 1889.
- 2 **R. N.**—R. B. CURTEIS, Ashenden, Tenterden, Kent. 1890.
- 5 **H. C.**—HERBERT PADWICK, Thorney, Emsworth, Hants. 1889.

**Class 184.—Coloured Dorking Hens.** [11 entries, none absent.]

- 17 I. (£2.)—WM. S. PINSENT, Rose Hall, Newton Abbot.  
 14 II. (£1.)—G. E. B. MUZEEN, Douthwaite Lodge, Kirby Moorside. 1889.  
 16 III. (10s.)—HERBERT PADWICK, Thorney, Emsworth, Hants. 1888.  
 13 B. N. & H. C.—JOHN MILLS, Higher Ending, Rochdale, Lancs.  
 H. C.—JAMES CRANSTON for No. 10; ARTHUR C. MAJOR for No. 12;  
 G. E. B. MUZEEN for No. 15.

**Class 185.—Coloured Dorking Cockerels.** [7 entries, 1 absent.]

- 24 I. (£2.)—WM. S. PINSENT, Rose Hall, Newton Abbot.  
 26 II. (£1.)—LADY WILSON, Chillingham Barns, Belford. Jan.  
 22 III. (10s.)—R. B. CURTEIS, Ashenden, Tenterden. Mar. 1.  
 20 B. N. & H. C.—R. BERRY & SON, 16, Ash Grove, Silsden, Yorks. Jan. 12.  
 21 Com.—JAMES CRANSTON, Tinwald House, Dumfries.

**Class 186.—Coloured Dorking Pullets.** [11 entries, 3 absent.]

- 34 I. (£2.)—WM. S. PINSENT, Rose Hall, Newton Abbot.  
 27 II. (£1.)—R. BERRY & SON, 16, Ash Grove, Silsden, Yorks. Jan. 12.  
 30 III. (10s.)—ANDREW CRICHTON, Glamis, N.B. Jan. 2.  
 37 B. N.—LADY WILSON, Chillingham Barns, Belford. Feb.

**Class 187.—Silver Grey Dorking Cocks.** [17 entries, 2 absent.]

- 38 I. (£2.)—PETER BLUNDELL, Ream Hills, Weeton, Kirkham, Lancs.  
 46 II. (£1.)—ARTHUR C. MAJOR, The Firs, Langley, Slough.  
 42 III. (10s.)—O. E. CRESSWELL, Morney Cross, Hereford.  
 40 B. N. & H. C.—JAMES CRANSTON, Tinwald House, Dumfries. 1889.  
 H. C.—O. E. CRESSWELL for No. 43; J. PETTIPHER for No. 47; MRS.  
 WACHER for No. 52; LADY WILSON for No. 54.

**Class 188.—Silver Grey Dorking Hens.** [12 entries, 1 absent.]

- 56 I. (£2.)—JAMES CRANSTON, Tinwald House, Dumfries. 1889.  
 61 II. (£1.)—ARTHUR C. MAJOR, The Firs, Langley, near Slough, Bucks.  
 58 III. (10s. & 59, B. N. & H. C.)—O. E. CRESSWELL, Morney Cross, near Hereford.  
 H. C.—PETER BLUNDELL for No. 55; JAMES CRANSTON for No. 57;  
 ARTHUR C. MAJOR for No. 60; R. REICH for No. 62; MRS. WACHER  
 for No. 64.

**Class 189.—Silver Grey Dorking Cockerels.** [6 entries, 1 absent.]

- 67 I. (£2.)—JAMES CLUNAS, 76, High Street, Elgin.  
 70 II. (£1.)—J. M. STOCKBRIDGE, Minster Thanet, Kent. Jan. 2.  
 69 III. (10s.)—ANDREW McREA, Clifton Hall, Ratho, N.B. Jan. 23.  
 68 B. N.—JAMES CRANSTON, Tinwald House, Dumfries.

**Class 190.—Silver Grey Dorking Pullets.** [8 entries, 1 absent.]

- 77 I. (£2.)—ANDREW McREA, Clifton Hall, Ratho, N.B. Jan. 23.  
 74 II. (£1.)—JAMES CLUNAS, 76, High Street, Elgin.  
 75 III. (10s.)—JAMES CRANSTON, Tinwald House, Dumfries.  
 73 B. N. & H. C.—JAMES CLUNAS, 76, High Street, Elgin.  
 76 H. C.—JAMES CRANSTON, Tinwald House, Dumfries.

**Class 191.—White or any other variety Dorking Cocks.**

[5 entries, none absent.]

- 81 I. (£2.)—O. E. CRESSWELL, Morney Cross, near Hereford. White.  
 83 II. (£1.)—A. E. W. DARBY, Little Ness, Shrewsbury. White.  
 85 III. (10s.)—JOSEPH PETTIPHER, Woodway House, near Banbury. White.  
 84 B. N.—A. E. W. DARBY, Little Ness, Shrewsbury. White.

**Class 192.**—*White or any other variety Dorking Hens.*

[5 entries, none absent.]

- 86 I. (£2) & 87 II. (£1.)—O. F. CRESSWELL, Morney Cross, Hereford. White.  
 88 III. (10s.)—A. E. W. DARBY, Little Ness, Shrewsbury. White.  
 90 R. N. & H. C.—JOSEPH PETTIPHER, Woodway House, near Banbury.  
 89 H. C.—A. E. W. DARBY, Little Ness, Shrewsbury. White.

**Class 193.**—*White or any other variety Dorking Cockerels.*

[5 entries, none absent.]

- 95 I. (£2.)—JOSEPH PETTIPHER, Woodway House, near Banbury.  
 91 II. (£1.)—WM. BURN, Phoenix House, Whitby, Yorks. White. Feb. 10.  
 94 III. (10s.)—H. J. GOODALL, The Priory, Melton Mowbray. Cuckoo. Feb. 26.  
 93 R. N. & H. C.—A. E. W. DARBY, Little Ness, Shrewsbury. White.  
 92 H. C.—FREDERICK CHATFIELD, Brampton Crofts, Appleby. White. Jan. 11.

**Class 194.**—*White or any other variety Dorking Pullets.*

[3 entries.]

- 97 I. (£2) and 96 II. (£1.)—A. E. W. DARBY, Little Ness, Shrewsbury. White.  
 98 III. (10s.)—H. J. GOODALL, The Priory, Melton Mowbray. Cuckoo. Feb. 26.

**Game.****Class 195.**—*Old English Game Cocks.* [17 entries, none absent.]

- 101 I. (£2.)—JOHN BROUGH, 22, London Road, Carlisle. Feb. 15, 1890.  
 109 II. (£1.)—MCHAFFIE & LOMAS, Silloth, Cumberland. May 29, 1890.  
 102 III. (10s.)—JOHN BROUGH, 22, London Road, Carlisle. Feb. 15, 1890.  
 113 R. N. & H. C.—C. WILLS, JUN., Burgh-by-Sands, Cumberland. Ap. 18, 1889.  
 H. C.—WM. LEWTHWAITE for No. 108; MISS NORMAN for No. 110; A. H. WILSON for No. 114.

**Class 196.**—*Old English Game Hens.* [15 entries, none absent.]

- 120 I. (£2.)—JOHN GRAHAM, Mungrisdale, Greystoke, Penrith. 1888.  
 127 II. (£1.)—THOMAS ROPER, Wetheral, Carlisle.  
 116 III. (10s.)—EDWARD BARNES, Godalming, Surrey. Over 1 year.  
 128 R. N. & H. C.—J. W. SIMPSON, Abbey Town, Silloth, Cumberland.  
 H. C.—JOHN BROUGH for No. 117; REV. H. W. HUTTON for No. 123;  
 WM. LEWTHWAITE for No. 124; MCHAFFIE & LOMAS for No. 125; J. W. SIMPSON for No. 129.

**Class 197.**—*Old English Game Cockerels.* [10 entries, 1 absent.]

- 131 I. (£2.)—JOHN BROUGH, 22, London Road, Carlisle. Jan. 18.  
 138 II. (£1.)—MISS NORMAN, Moor Park, Kirkbampton, Carlisle. Jan. 10.  
 134 III. (10s.)—J. CRAIGHILL, Warwick Bridge, Carlisle. Feb. 8.  
 136 R. N. & H. C.—MCHAFFIE & LOMAS, Park House, Silloth. Jan. 3 & Feb. 10.

**Class 198.**—*Old English Game Pullets.* [9 entries, 1 absent.]

- 141 I. (£2.) & 142 II. (£1.)—JOHN BROUGH, 22, London Rd. Carlisle. Jan. 18.  
 147 III. (10s.)—MCHAFFIE & LOMAS, Park House, Silloth. Jan. 3.  
 143 R. N. & H. C. BROUGH & JACKSON, 22, London Road, Carlisle. Feb. 2.

**Class 199.**—*Indian Game Cocks.* [9 entries, 2 absent.]

- 152 I. (£2.)—JOHN FRAYN, St. Stephen's, Launceston, Cornwall. 1889.  
 158 II (£1.)—G. T. WHITFIELD, Colebridge, Gloucester.  
 155 III. (10s.)—A. H. HAWKEY, Wadebridge, Cornwall. 1890.

- 151 **R. N. & H. C.**—WM. BRENT, Clampit Farm, Callington. Over 1 year.  
**H. C.**—ABBOT BROS. for No. 150; JAMES FRAYNE for No. 153; DR.  
 GOODALL for No. 154.

**Class 200.**—*Indian Game Hens.* [8 entries, 1 absent.]

- 164 **I.** (£2.)—A. H. HAWKEY, Wadebridge, Cornwall. 1890.  
 161 **II.** (£1.)—JOHN FRAYN, St. Stephen's, Launceston. 1889.  
 162 **III.** (10s.)—JAMES FRAYNE, Piper's Pool, Launceston.  
 166 **R. N. & H. C.**—GEO. T. WHITFIELD, Colebridge, Gloucester.  
**H. C.**—WM. BRENT for No. 159; JOHN CROSS for No. 160.

**Class 201.**—*Indian Game Cockerels.* [13 entries, 1 absent.]

- 172 **I.** (£2.)—JOHN FRAYN, St. Stephen's, Launceston.  
 178 **II.** (£1.)—A. C. WEST, Goodleigh, Devon. Jan. 28.  
 167 **III.** (10s.)—R. & H. ABBOT, Hingham, Norfolk. Jan.  
 176 **R. N. & H. C.**—TOM HAWKEY, Wadebridge, Cornwall. Jan.  
**H. C.**—MRS. T. BROOK for No. 169; JAMES FRAYNE for No. 173; G. S.  
 WYNN for No. 179. **Com.**—JOHN SPRY for No. 177.

**Class 202.**—*Indian Game Pullets.* [12 entries, none absent.]

- 187 **I.** (£2.)—A. H. HAWKEY, Wadebridge, Cornwall. Jan.  
 184 **II.** (£1.)—JOHN FRAYN, St. Stephen's, Launceston.  
 182 **III.** (10s.)—MRS. T. BROOK, Vine Street, Winkleigh, Devon.  
 190 **R. N. & H. C.**—G. T. WHITFIELD, Colebridge, Gloucester. Jan. 3.

## Houdans.

**Class 203.**—*Houdan Cocks.* [3 entries.]

- 194 **I.** (£2) and 193 **II.** (£1.)—S. W. THOMAS, Glasfryn, Cockett, Swansea.  
 192 **III.** (10s.)—REV. G. T. LAYCOCK, Terwick Rectory, Petersfield, Hants.

**Class 204.**—*Houdan Hens.* [7 entries, none absent.]

- 200 **I.** (£2), and 201 **II.** (£1.)—S. W. THOMAS, Glasfryn, Cockett, Swansea.  
 195 **III.** (10s.)—REV. F. COOKE, Clungunford Rectory, Salop. 2 years.  
 196 **R. N. & H. C.**—J. HILL, Bridgend Mills, Lostwithiel. 3 years.  
 199 **H. C.**—REV. R. S. MITCHISON, Barby Rectory, Rugby.

**Class 205.**—*Houdan Cockerels.* [4 entries.]

- 202 **I.** (£2)—REV. F. COOKE, Clungunford Rectory, Salop. Jan. 1.  
 204 **II.** (£1), and 203 **III.** (10s.)—J. HILL, Bridgend Mills, Lostwithiel. Feb.  
 13 & Jan. 1.  
 205 **R. N.**—REV. RICHARD S. MITCHISON, Barby Rectory, Rugby.

**Class 206.**—*Houdan Pullets.* [5 entries, none absent.]

- 208 **I.** (£2.)—J. HILL, Bridgend Mills, Lostwithiel. Feb. 13.  
 206 **II.** (£1) and 207 **III.** (10s.)—REV. F. COOKE, Clungunford Rectory,  
 Salop. Jan. 1.  
 209 **R. N.**—J. HILL, Bridgend Mills, Lostwithiel. Jan. 1.

## Other French Breeds.

**Class 207.**—*Cocks.* [6 entries, none absent.]

- 215 **I.** (£2.)—FRANCIS VALPY, St. Heliers, Jersey. Mar. 1889.  
 211 **II.** (£1.)—J. H. BRODRICK, The Attleburys, Water Orton.  
 (French Crève and Crève Cœur.)

- 214 **III.** (10s.)—S. W. THOMAS, Glasfryn, Cockett, Swansea. (Crève.)  
 213 **R. N. & H. C.**—JOB RAWNSLEY, Langley Farm, Bingley. (Crève.)  
 216 **H. C.**—FRANCIS VALPY, Mar. 1890.

**Class 208.**—*Hens.* [8 entries, none absent.]

- 219 **I.** (£2.)—D. HASTINGS, Darvel, Ayrshire. June 1889.  
 220 **II.** (£1.)—F. MITCHELL, Shay Grove, Crosshills.  
 218 **III.** (10s.)—J. H. BRODRICK, The Attleburys, Water Orton. (Crève Cœur.)  
 222 **R. N. & H. C.**—S. W. THOMAS, Glasfryn, Cockett, Swansea. (Crève.)  
**H. C.**—J. H. BRODRICK for No. 217 (Crève Cœur); JOB RAWNSLEY for No. 221, (Crève).  
 223 **Com.**—FRANCIS VALPY, Mar. 1890.

**Class 209.**—*Cockerels.* [2 entries.]

- 226 **I.** (£2) and 225 **II.** (£1.)—FRANCIS VALPY, St. Heliers, Jersey. Feb.

**Class 210.**—*Pullets.* [2 entries.]

- 228 **II.** (£1) and 227 **III.** (10s.)—FRANCIS VALPY, St. Heliers, Jersey. Feb.

## Brahmas.

**Class 211.**—*Brahma Cocks.* [5 entries, 1 absent.]

- 229 **I.** (£2.)—JOHN BROOKE, Heaton, Bradford, Yorks.  
 232 **II.** (£1.)—G. H. WOOD & R. W. WEBSTER, Iver Heath, Uxbridge. 1890.  
 230 **III.** (10s.)—T. R. SIDGWICK, Hovingham, York.  
 231 **R. N. & H. C.**—S. W. THOMAS, Glasfryn, Cockett, Swansea.

**Class 212.**—*Brahma Hens.* [8 entries, 1 absent.]

- 235 **I.** (£2.)—W. R. GARNER, Dyke Bourne, Lincs. 2 years.  
 240 **II.** (£1.), and 239 **III.** (10s.)—G. H. WOOD & R. W. WEBSTER, Iver Heath, Uxbridge. 1889 & 1890.  
 234 **R. N. & H. C.**—JOHN BROOKE, Heaton, Bradford, Yorks.  
**H. C.**—T. S. MAY for No. 236; T. R. SIDGWICK for No. 237; MRS. STANYFORTH for No. 238.

**Class 213.**—*Brahma Cockerels.* [7 entries, 1 absent.]

- 247 **I.** (£2.)—REV. H. BURTON, Fauls Vicarage, Whitchurch, Salop. Jan. 9.  
 248 **II.** (£1.)—J. TAYLOR, Alsager, Stoke-on-Trent. Jan. 2.  
 243 **III.** (10s.) and 242 **R. N.**—ALFRED ASHTON, Kermincham Lodge, Holmes Chapel, Cheshire. Jan.

**Class 214.**—*Brahma Pullets.* [8 entries, none absent.]

- 249 **I.** (£2) and 250 **II.** (£1.)—ALFRED ASHTON, Kermincham Lodge, Holmes Chapel, Cheshire. Jan.  
 254 **III.** (10s.)—REV. H. BURTON, Fauls Vicarage, Whitchurch, Salop. Jan. 1.  
 256 **R. N. & H. C.**—J. TAYLOR, Alsager, Stoke-on-Trent. Jan. 2.  
 255 **H. C.**—W. R. GARNER, Dyke, Bourne. Jan. 3.  
 251 **Com.**—DR. P. L. BENSON, Steeple Claydon. Jan. 5.

## Cochins.

**Class 215.**—*Cochin Cocks.* [11 entries, 3 absent.]

- 262 **I.** (£2.)—MRS. KITE POWELL, Elm Lodge, Chesterfield, Derbyshire.  
 264 **II.** (£1.)—G. H. PROCTER, Flass House, Durham. 1889.  
 266 **III.** (10s.)—G. H. WOOD & R. W. WEBSTER, Iver Heath, Uxbridge. 1890.  
 265 **R. N. & H. C.**—MRS. SCRIVEN, Normandy Villa, Shipley, Yorks.  
**H. C.**—H. J. GOODALL for No. 257; G. H. PROCTER for No. 263.



**Class 216.—Cochin Hens.** [8 entries, 3 absent.]

- 272 I. (£2).—G. H. PROCTER, Flass House, Durham. 1889.  
 271 II. (£1).—MRS. KITE POWELL, Elm Lodge, Chesterfield.  
 273 III. (10s.).—G. H. PROCTER, Flass House, Durham. 1889.  
 274 R. N. & H. C.—MRS. SCRIVEN, Normandy Villa, Shipley, Yorks.

**Class 217.—Cochin Cockerels.** [9 entries, 1 absent.]

- 279 I. (£2).—H. J. GOODALL, The Priory, Melton Mowbray. Jan. 8.  
 281 II. (£1).—TOM SOWERBY, Elm Road, Cleethorpes, Lincs. Jan. 5.  
 282 III. (10s.) and 281 R. N.—MRS. SCRIVEN, Normandy Villa, Shipley, Yorks.

**Class 218.—Cochin Pullets.** [9 entries, 2 absent.]

- 293 I. (£2) & 292 II. (£1).—TOM SOWERBY, Elm Road, Cleethorpes. Jan. 5.  
 289 III. (10s.).—MRS. SCRIVEN, Normandy Villa, Shipley, Yorks.  
 285 R. N. & H. C.—A. ASHTON, Kermincham Lodge, Holmes Chapel, Ches. Feb.  
 290 H. C.—MRS. SCRIVEN, Normandy Villa, Shipley, Yorks.

**Langshans.****Class 219.—Langshan Cocks.** [14 entries, 1 absent.]

- 299 I. (£2).—PHILLIP MARSH, Bedminster, Bristol. March, 1889.  
 301 II. (£1).—F. O. PIERCY, The Elms, Lowthorpe, Hull. 1889.  
 298 III. (10s.).—REV. G. T. LAYCOCK, Terwick Rectory, Petersfield.  
 305 R. N. & H. C.—RALPH WAITON, Tickhill, Rotherham. Jan. 25, 1890.  
 H. C.—J. A. HEWETSON for No. 295; F. O. PIERCY for No. 300.  
 Com.—REV. G. T. LAYCOCK for No. 297; WM. WILLIAMS for No. 306.

**Class 220.—Langshan Hens.** [14 entries, none absent.]

- 313 I. (£2).—REV. G. T. LAYCOCK, Terwick Rectory, Petersfield, Hants.  
 320 II. (£1).—J. W. WALKER, Oxford Lodge, Henley-on-Thames. 1889.  
 316 III. (10s.).—F. O. PIERCY, The Elms, Lowthorpe, Hull. 1890.  
 310 R. N. & H. C.—J. A. HEWETSON, The Hall, Wawne, near Hull.  
 H. C.—REV. G. T. LAYCOCK for No. 312; PHILLIP MARSH for No. 314.

**Class 221.—Langshan Cockerels.** [5 entries, none absent.]

- 325 I. (£2) and 326 II. (£1).—F. O. PIERCY, The Elms, Lowthorpe, Hull. Jan.  
 322 III. (10s.) and 323 R. N.—REV. G. T. LAYCOCK, Terwick Rectory, Petersfield, Hants. Jan. 5.

**Class 222.—Langshan Pullets.** [7 entries, none absent.]

- 331 I. (£2).—F. O. PIERCY, The Elms, Lowthorpe, Hull. Jan.  
 329 II. (£1) and 330 III. (10s.).—REV. G. T. LAYCOCK, Terwick Rectory, Petersfield, Hants. Jan. 5.  
 328 R. N.—A. CHASE, Ewell, Surrey. Feb. 7.

**Wyandottes.****Class 223.—Wyandotte Cocks.** [15 entries, 1 absent.]

- 346 I. (£2).—G. T. WHITFIELD, Colcbridge, Gloucester.  
 339 II. (£1).—MRS. FRANKLIN, Syston Old Hall, Grantham. Mar. 1890.  
 338 III. (10s.).—REV. F. COOKE, Clungunford Rectory, Salop. May 1890.  
 334 R. N. & H. C.—ABBOT BROS., Hingham, Norfolk. 1890.  
 H. C.—REV. G. T. LAYCOCK for No. 341; W. H. MIDGLEY for No. 342;  
 MRS. PARKE for No. 344; G. T. WHITFIELD for No. 347.

**Class 224.—Wyandotte Hens.** [15 entries, 1 absent.]

- 349 I. (£2.)—ABBOT BROS., Hingham, Norfolk. 1890.  
 361 II. (£1.)—G. SQUIBB, Danny Lodge, Hassocks, Sussex. Apr. 1890.  
 353 III. (10s.)—MRS. FRANKLIN, Syston Old Hall, Grantham. 1890.  
 358 R. N. & H. C.—MRS. E. OLIVER, Fletton, Peterborough. Apr. 1890.

**Class 225.—Wyandotte Cockerels.** [9 entries, 1 absent.]

- 371 I. (£2.)—MRS. SARA H. SANDFORD, Whitchurch, Salop. Jan. 8.  
 368 II. (£1.)—MRS. FRANKLIN, Syston Old Hall, Grantham. Mar. 13 or 19.  
 365 III. (10s.)—C. H. BANTOFT, Whinbergh Park, East Dereham. Jan. 30.  
 364 R. N. & H. C.—ABBOT BROS., Hingham, Norfolk. Jan.  
 367 H. C.—REV. F. COOKE, Clungunford Rectory, Salop. Jan. 1.

**Class 226.—Wyandotte Pullets.** [11 entries, none absent.]

- 380 I. (£2.)—MRS. FRANKLIN, Syston Old Hall, Grantham. Mar. 13 or 19.  
 382 II. (£1.)—MRS. SARA H. SANDFORD, Whitchurch, Salop. Jan. 8.  
 377 III. (10s.)—WM. BYGOTT, JUN., Rye Hill Farm, Ulceby, Lincs. Jan. 2.  
 373 R. N. & H. C.—ABBOT BROS., Hingham, Norfolk. Jan.

**Plymouth Rocks.****Class 227.—Plymouth Rock Cocks.** [14 entries, 1 absent.]

- 391 I. (£2.)—L. & S. JACKSON, Manor Farm, Ringway, Altrincham.  
 386 II. (£1) & 387 III. (10s.)—R. BUTTERFIELD, Nafferton Hall, Hull. 1890.  
 392 R. N. & H. C.—SYDNEY F. JACKSON, Bourne Place, Bexley, Kent.  
 390 H. C.—JOHN HARTLEY, The Knowle, Morley, Yorks.  
 394 Com.—J. H. PEACE, Northfield, Knowle, Warwick. June 1890.

**Class 228.—Plymouth Rock Hens.** [14 entries, 1 absent.]

- 401 I. (£2.)—JOHN HARTLEY, The Knowle, Morley, Yorks.  
 399 II. (£1.)—R. BUTTERFIELD, Nafferton Hall, Hull. 1890.  
 398 III. (10s.)—R. BUTTERFIELD, Nafferton Hall, Hull. 4 years.  
 407 R. N. & H. C.—J. H. PEACE, Northfield, Knowle, Warwick. June 1890.  
 400 H. C.—JOHN HARDON, Old Town, Kirkby Lonsdale.  
 Com.—J. H. PEACE for No. 406; R. W. WEBSTER for No. 411.

**Class 229.—Plymouth Rock Cockerels.** [20 entries, 2 absent.]

- 424 I. (£2.)—JOHN HARDON, Old Town, Kirkby Lonsdale. Jan. 15.  
 428 II (£1.)—WM. PARKER, Rigmaden Park, Kirkby Lonsdale. Feb. 2.  
 415 III. (10s.)—R. J. BROWNING, Quedgeley, Gloucester. Jan. 3.  
 419 R. N. & H. C.—W. EVERINGTON, Weasenham, Swaffham, Norfolk. Feb. 14.  
 H. C.—R. BUTTERFIELD for No. 417; J. W. HALL for No. 423; REV. F. LLOYD for No. 426.  
 Com.—R. GARLICK for No. 422; MISS STUART for No. 430; J. WHEELER for No. 431.

**Class 230.—Plymouth Rock Pullets.** [20 entries, 1 absent.]

- 442 I. (£2.)—L. & S. JACKSON, Manor Farm, Ringway, Altrincham.  
 445 II. (£1)—L. H. & J. NUTTER, Burton, Westmoreland. Jan. 3.  
 433 III. (10s.)—C. H. BANTOFT, Whinbergh Park, E. Dereham. Feb. 7.  
 446 R. N. & H. C.—WM. PARKER, Rigmaden Park, Kirkby Lonsdale. Feb. 2.  
 432 H. C.—J. W. ADLINGTON. 451 Com.—J. WHEELER.

## Scotch Greys.

Class 231.—*Scotch Grey Cocks.* [2 entries.]

- 453 I. (£2).—D. HASTINGS, Irving Bank Cottage, Darvel, N.B. June 1890.  
 452 II. (£1).—JOHN CARSWELL, Airth Mains, Larbert, N.B. May 1890.

Class 232.—*Scotch Grey Hens.* [3 entries.]

- 454 I. (£2).—JOHN CARSWELL, Airth Mains, Larbert, N.B. Apr. 1889.  
 456 II. (£1).—W. S. MITCHELL, Castle Orchards, Airth, Larbert, N.B.  
 455 III. (10s.).—D. HASTINGS, Darvel, Ayrshire. June 1890.

Class 233.—*Scotch Grey Cockerels.* [No entry.]Class 234.—*Scotch Grey Pullets.* [1 entry.]

- 457 II. (£1).—WM. S. MITCHELL, Castle Orchards, Airth, Larbert, N.B.

## Minorcas.

Class 235.—*Minorca Cocks.* [10 entries, 1 absent.]

- 461 I. (£2).—A. LEWIS, Cornhill, Bridgwater, Somerset.  
 459 II. (£1).—JOHN GLANFIELD, The Riffel, Torquay. Aug. 1890.  
 464 III. (10s.) & 465 R. N. & H. C.—A. G. PITTS, Highbridge. Apr. & May, 1890.  
 467 H. C.—LADY WILSON, Chillingham Barns, Northumberland. 1890.

Class 236.—*Minorca Hens.* [23 entries, 2 absent.]

- 472 I. (£2).—SERGT. COLTON, Market St., Ilkeston, Derbyshire. June 28, 1890.  
 477 II. (£1).—F. MITCHELL, Shay Grove, Crosshills, *via* Keighley.  
 469 III. (10s.).—H. ALLEN, Railway Parade, Bridgwater. Apr. 18, 1890.  
 478 R. N. & H. C.—T. NIGHTINGALE, 76, Aberdeen St., Birmingham. May 5.  
 H. C.—T. FOTHERGILL for No. 474; W. H. STOYEL for No. 488.  
 Com.—SCOTT ROBINSON for No. 485.

Class 237.—*Minorca Cockerels.* [10 entries, none absent.]

- 494 I. (£2).—J. W. CROSSMAN, Worlaby Hall, Brigg. Jan. 14.  
 495 II. (£1).—HAWKHURST POULTRY YARDS, Bridgwater, Som. Jan. 2.  
 500 III. (10s.).—WM. STRIBLING, Colnbrook, Slough. Jan. 30.  
 496 R. N. & H. C.—J. W. LABEY, East Lynne, St. Luke's, Jersey. Jan. 21.  
 Com.—ABBOT BROS. for No. 491; F. MITCHELL for No. 498.

Class 238.—*Minorca Pullets.* [8 entries, none absent.]

- 503 I. (£2) and 502 II. (£1).—R. BUTTERFIELD, Nafferton Hall, Hull. Jan.  
 505 III. (10s.).—HAWKHURST POULTRY YARDS, Bridgwater, Som. Jan. 2.  
 508 R. N. & Com.—F. O. PIERCY, The Elms, Lowthorpe, Hull. Jan.

## Andalusians.

Class 239.—*Andalusian Cocks.* [8 entries, none absent.]

- 512 I. (£2).—JAMES GREENWOOD, Exley Head, Keighley.  
 514 II. (£1).—E. MERRALL, Manor Heath, East Morton, Yorks. Mar. 1890.  
 510 III. (10s.).—REV. E. R. O. BRIDGEMAN, Blymhill Rectory, Shifnal.  
 511 R. N. & H. C.—D. BUTTERFIELD, 3, Laythorpe Ter., East Morton, Yorks.

Class 240.—*Andalusian Hens.* [12 entries, none absent.]

- 523 I. (£2).—R. LITTLE, JUN., Rokeby Cottage, Glossop. May 1890.  
 517 II. (£1).—ABBOT BROS., Hingham, Norfolk. 1890.

- 526 III. (10s.)—G. S. OLDHAM, Sherington, Newport Pagnell. Apr. 1890.  
 524 R. N. & H. C.—E. MERRALL, Manor Heath, East Morton, Yorks. Mar. 1890.  
 H. C.—REV. E. R. O. BRIDGEMAN for No. 518; J. GREENWOOD for No.  
 520; REV. R. T. THORNTON for No. 528.

**Class 241.**—*Andalusian Cockerels.* [5 entries, none absent.]

- 531 I. (£2.)—J. GREENWOOD, Exley Head, Keighley. Jan. 4.  
 532 II. (£1.)—E. MERRALL, Manor Heath, East Morton, Yorks. Jan.  
 529 III. (10s.)—ABBOT BROS., Hingham, Norfolk. Feb.  
 530 R. N. & H. C.—D. BUTTERFIELD, 3, Laythorpe Ter., E. Morton, Yorks. Jan. 2.

**Class 242.**—*Andalusian Pullets.* [8 entries, none absent.]

- 535 I. (£2.)—D. BUTTERFIELD, 3, Laythorpe Ter., E. Morton, Yorks. Feb. 2.  
 539 II. (£1.)—E. MERRALL, Manor Heath, East Morton, Yorks. Jan.  
 541 III. (10s.)—REV. R. T. THORNTON, Ravensdale, Tunbridge Wells. Feb.  
 536 R. N. & H. C.—J. GREENWOOD, Exley Head, Keighley. Jan. 4.

## Leghorns.

**Class 243.**—*Leghorn Cocks.* [8 entries, 1 absent.]

- 546 I. (£2.)—H. D. LADDS, Swanley Junction, Kent. Apr. 1890.  
 547 II. (£1.)—F. MITCHELL, Shay Grove, Crosshills, *via* Keighley.  
 548 III. (10s.)—JOSEPH PRIDE, Thorverton, Devon. Apr. 1890.  
 545 R. N. & H. C.—JOHN HURST, South Terrace, Glossop. Apr. 1890.

**Class 244.**—*Leghorn Hens.* [6 entries, 1 absent.]

- 551 I. (£2.)—JOHN HURST, South Terrace, Glossop. Apr. 1890.  
 554 II. (£1.)—WADE BROS., Silsden, *via* Keighley.  
 550 III. (10s.)—JOHN BERRY, 40, Aireview St., Silsden, Yorks.  
 552 R. N. & H. C.—F. MITCHELL, Shay Grove, Crosshills, *via* Keighley.

**Class 245.**—*Leghorn Cockerels.* [12 entries, 3 absent.]

- 565 I. (£2.)—MRS. SINKINS, Alder Moor House, Southampton. Feb. 1.  
 558 II. (£1.)—R. BUTTERFIELD, Nafferton Hall, Hull. Jan.  
 566 III. (10s.)—TILLITSON & NIXON, 56, Keighley Rd., Silsden, Yorks. Jan. 2.  
 557 R. N. & H. C.—J. BERRY, 40, Aireview Street, Silsden, Yorks. Jan. 3.  
 564 H. C.—MRS. SHAW, Brooklands, near Halifax. Jan.  
 567 Com.—WADE BROS., Silsden, Yorks. Jan. 15.

**Class 246.**—*Leghorn Pullets.* [14 entries, 1 absent.]

- 575 I. (£2.)—M. JACKSON, High Green Farm, Silsden, Yorks. Jan. 16.  
 581 II. (£1.)—WADE BROS., Silsden, *via* Keighley. Jan. 15.  
 580 III. (10s.)—TILLITSON & NIXON, Silsden, Yorks. Jan. 2.  
 569 R. N. & H. C.—JOHN BERRY, 40, Aireview Street, Silsden, Yorks. Jan. 3.  
 570 H. C.—R. BUTTERFIELD, Nafferton Hall, Hull. Jan.  
 572 Com.—H. FRY, Silsden, Yorks. Jan. 6.

## Hamburgs.

**Class 247.**—*Hamburg Cocks, any variety.* [9 entries, 1 absent.]

- 586 I. (£2.)—REV. G. T. LAYCOCK, Twick Rectory, Petersfield, Hants.  
 588 II. (£1.)—FREDERICK MITCHELL, Shay Grove, Crosshills, *via* Keighley.  
 589 III. (10s.)—H. PICKLES, Earby, Leeds (Silver Spangled).  
 583 R. N. & H. C.—REV. S. ASHWELL, Fimmere Rectory, Buckingham (Silver  
 Spangled). Mar. 1890.  
 H. C.—REV. S. ASHWELL for No. 582; REV. G. T. LAYCOCK for No. 587;  
 LADY WOLSELEY for No. 590.

**Class 248.**—*Hamburgh Hens, any variety.* [10 entries, 1 absent.]

- 596 I. (£2.)—F. MITCHELL, Shay Grove, Crosshills, *via* Keighley.  
 598 II. (£1.)—R. RIMMER, Churchtown, Southport (Black). Jan. 10, 1890.  
 597 III. (10s.)—H. PICKLES, Earby, Leeds (Silver Spangled).  
 592 R. N. & H. C.—A. HARROWING, The Old Hall, Ruswarp, Whitby.  
 H. C.—REV. G. T. LAYCOCK for No. 595; MISS STUART for No. 599;  
 LADY WOLSELEY for No. 600.

**Class 249.**—*Hamburgh Cockerels, any variety.* [7 entries, none absent.]

- 602 I. (£2.)—M. JACKSON, Silsden, Yorks (Gold Pencil). Jan. 16.  
 604 II. (£1.)—H. PICKLES, Earby, Leeds (Silver Spangled). Feb. 14.  
 603 III. (10s.)—F. MITCHELL, Shay Grove, Crosshills, *via* Keighley.

**Class 250.**—*Hamburgh Pullets, any variety.* [6 entries, none absent.]

- 609 I. (£2.)—F. MITCHELL, Shay Grove, Crosshills, *via* Keighley.  
 610 II. (£1.)—H. PICKLES, Earby, Leeds (Silver Pencilled). Feb. 14.  
 608 III. (10s.)—C. A. KEMBALL, Earls Acre, Plymouth (Black). Jan. 2.

**Any Other Variety.<sup>1</sup>****Class 251.**—*Any other variety, Cocks.* [6 entries, 1 absent.]

- 618 I. (£2.)—JOB RAWNSLEY, Langley Farm, Bingley (Poland).  
 619 II. (£1.)—G. T. WHITFIELD, Colebridge, Gloucester (Asecl).  
 617 III. (10s.)—J. POWELL, Myrtle Royd, Bingley (Black Spanish). Mar. 4, 1890.  
 615 R. N. & H. C.—F. MITCHELL, Shay Grove, Crosshills, *via* Keighley (Polish).  
 616 Com.—MRS. W. H. MITCHELL, Elmdene, Kenilworth (Orpington).

**Class 252.**—*Any other variety, Hens.* [5 entries, 1 absent.]

- 622 I. (£2.)—J. POWELL, Myrtle Royd, Bingley (Black Spanish). Mar. 4, 1890.  
 621 II. (£1.)—F. MITCHELL, Shay Grove, Crosshills, *via* Keighley (Polish).  
 624 III. (10s.)—G. T. WHITFIELD, Colebridge, Gloucester (Asecl).  
 623 R. N. & Com.—JOB RAWNSLEY, Langley Farm, Bingley (Spanish).

**Class 253.**—*Any other variety, Cockerels.* [2 entries.]

- 625 I. (£2.)—F. HARVEY, North St., Lostwithiel (Spanish Whitefaced). Jan. 2.  
 626 II. (£1.)—J. W. LABEY, E. Lynne, St. Luke's, Jersey (Orpington). Feb. 1.

**Class 254.**—*Any other variety, Pullets.* [2 entries.]

- 627 I. (£2.)—F. HARVEY, North St., Lostwithiel (Spanish Whitefaced). Jan. 2.  
 628 II. (£1.)—J. W. LABEY, East Lynne, Jersey (Orpington). Feb. 1.

**Table Fowls.****Class 255.**—*Pair of Cockerels of 1891, of any Pure Breed.*

[6 entries, 2 absent.]

- 630 I. (£2.)—WM. BRENT, Clampit Farm, Callington (Indian Game).  
 634 II. (£1.)—J. WHITE, Worlaby, Northallerton (Coloured Dorking). Feb. 16.  
 633 III. (10s.)—WM. STANFORD, Steyning, Sussex (Coloured Dorking).

**Class 256.**—*Pair of Pullets of 1891, of any Pure Breed.*

[7 entries, none absent.]

- 635 I. (£2.)—J. W. ADLINGTON, Kirk Langley, Derby (Plymouth Rock Barred). Jan. 14 & 28.  
 640 II. (£1.)—J. FRAYNE, Piper's Pool, Launceston (Indian Game).

<sup>1</sup> Bantams excepted.

- 636 **III.** (10s.)—WM. BRENT, Clampit Farm, Callington (Indian Game).  
**H. C.**—WM. BYGOTT, JUN., for No. 637; WM. STANFORD for No. 641.

**Class 257.**—*Pair of Cockerels of 1891, of a First Cross from any Pure Breeds.* [6 entries, 1 absent.]

- 646 **I.** (£2).—LADY WILSON, Chillingham Barns, Belford (Indian Game & Coloured Dorking). Jan. 10.  
 644 **II.** (£1).—MRS. STANYFORTH, Kirk Hammerton Hall, York (Silver Grey Dorking & Indian Game). Feb.  
 642 **III.** (10s.)—MISS M. DOLBEN, Ipsley Rectory, Redditch (Indian Game & Dorking). Jan. 7.

**Class 258.**—*Pair of Pullets of 1891, of a First Cross from any Pure Breeds.* [8 entries, 3 absent.]

- 655 **I.** (£2).—LADY WILSON, Chillingham Barns, Belford (Indian Game & Coloured Dorking). Jan. 10.  
 653 **II.** (£1).—MRS. STANYFORTH, Kirk Hammerton Hall, York (Silver Grey Dorking & Indian Game). Feb.  
 648 **III.** (10s.)—RALPH ARTHUR, Torbrian Rectory, Newton Abbot (Langshan & Indian Game). Mar. 8.  
 651. **H. C.**—PHILIP B. GOVETT (Dorking & (Game or) Brahma).

## DUCKS.

### Aylesbury.

**Class 259.**—*Aylesbury Drakes.* [11 entries, 2 absent.]

- 658 **I.** (£2).—H. DIGBY, The Burne, Birchencliff, Huddersfield.  
 656 **II.** (£1).—BROWN & HICKS, 52, Kingsland Road, Bristol.  
 666 **III.** (10s.)—W. WESTON, 31 Mount Street, Aylesbury. 1889.  
 665 **R. N. & H. C.**—R. J. SERGEANT, Thornton Abbey, Ulceby, Lincs.  
 659 **H. C.**—T. G. HOULTON, South Killingholme, Ulceby. 1890.  
 662 **Com.**—MRS. M. A. E. PARSONS, Langton, Tunbridge Wells. 1889.

**Class 260.**—*Aylesbury Ducks.* [8 entries, none absent.]

- 669 **I.** (£2).—H. DIGBY, The Burne, Birchencliff, Huddersfield. 1888.  
 667 **II.** (£1).—BROWN & HICKS, 52, Kingsland Road, Bristol.  
 673 **III.** (10s.)—R. J. SERGEANT, Thornton Abbey, Ulceby.  
 670 **R. N. & H. C.**—T. G. HOULTON, South Killingholme, Lincs. 1890.  
 668 **H. C.**—W. BYGOTT, JUN., Rye Hill Farm, Ulceby. Mar. 1890.

**Class 261.**—*Aylesbury Young Drakes.* [8 entries, 1 absent.]

- 676 **I.** (£2).—H. DIGBY, The Burne, Birchencliff, Huddersfield. Mar. 7.  
 681 **II.** (£1).—W. WESTON, 31, Mount Street, Aylesbury.  
 680 **III.** (10s.) & 679 **R. N.**—R. J. SERGEANT, Thornton Abbey, Ulceby. Mar. 12.

**Class 262.**—*Aylesbury Ducklings.* [8 entries, 1 absent.]

- 684 **I.** (£2).—H. DIGBY, The Burne, Birchencliff, Huddersfield. Mar. 7.  
 689 **II.** (£1).—W. WESTON, 31, Mount Street, Aylesbury.  
 687 **III.** (10s.)—R. J. SERGEANT, Thornton Abbey, Ulceby. Mar. 12.  
 683 **R. N.**—WM. BYGOTT, JUN., Rye Hill Farm, Ulceby, Lincs. March 9.  
 688 **Com.**—R. J. SERGEANT. Apr. 2.

## Rouen.

**Class 263.**—*Rouen Drakes.* [12 entries, 2 absent.]

- 695 **I.** (£2).—T. G. HOULTON, South Killingholme, Ulceby. 1889.  
 701 **II.** (£1).—T. WAKEFIELD, Lowton, Newton-le-Willows, Lancs.

- 702 **III.** (10s.)—LADY WILSON, Chillingham Barns, Belford. 1887.  
 697 **R. N. & H. C.**—G. H. PROCTER, Flass House, Durham.  
**H. C.**—WM. BYGOTT, JUN., for No. 691; F. E. RICHARDSON for No. 698.  
 692 **Com.**—WM. BYGOTT, JUN.

**Class 264.**—*Rouen Ducks.* [15 entries, 1 absent.]

- 703 **I.** (£2.)—WM. BYGOTT, JUN., Rye Hill Farm, Uleceby, Lincs. 1890.  
 706 **II.** (£1.)—T. G. HOULTON, South Killingholme, Uleceby, Lincs. 1889.  
 708 **III.** (10s.)—G. H. PROCTER, Flass House, Durham.  
 715 **R. N. & H. C.**—T. WAKEFIELD, Lowton, Newton-le-Willows, Lanes.  
**H. C.**—WM. BYGOTT, JUN., for No. 701; REV. F. COOKE for No. 705; LADY WILSON for No. 716.

**Class 265.**—*Rouen Young Drakes.* [6 entries, 1 absent.]

- 718 **I.** (£2.)—WM. BYGOTT, JUN., Rye Hill Farm, Uleceby, Lincs. Jan. 3.  
 722 **II.** (£1) & 721 **III.** (10s.)—R. J. SERGEANT, Thornton Abbey, Lincs. Mar. 12.  
 720 **R. N.**—T. G. HOULTON, South Killingholme, Uleceby.

**Class 266.**—*Rouen Ducklings.* [6 entries, 1 absent.]

- 727 **I.** (£2) & 728 **II.** (£1.)—R. J. SERGEANT, Thornton Abbey, Lincs. Mar. 20.  
 724 **III.** (10s.)—WM. BYGOTT, JUN., Rye Hill Farm, Uleceby, Lincs. Jan. 3.  
 726 **R. N.**—T. G. HOULTON, South Killingholme, Uleceby.

## Pekin.

**Class 267.**—*Pekin Drakes.* [6 entries, none absent.]

- 732 **I.** (£2.)—BROWN & HICKS, 52, Kingsland Road, Bristol.  
 730 **II.** (£1.)—T. ALLEN, Crookwood, Devizes. Apr. 1889.  
 735 **III.** (10s.) and 734 **R. N.**—F. DAVIS, Woolashill, Pershore.

**Class 268.**—*Pekin Ducks.* [6 entries, none absent.]

- 739 **I.** (£2) and 740 **II.** (£1.)—F. DAVIS, Woolashill, Pershore.  
 738 **III.** (10s.)—BROWN & HICKS, 52, Kingsland Road, Bristol.  
 741 **R. N.**—H. WITHERS, Ashley Road, Bristol. July 23, 1890.

**Class 269.**—*Pekin Young Drakes.* [7 entries, none absent.]

- 743 **I.** (£2.)—T. ALLEN, Crookwood, Devizes. Mar.  
 744 **II.** (£1.)—BROWN & HICKS, 52, Kingsland Road, Bristol. Apr. 30.  
 742 **III.** (10s.)—THOMAS ALLEN, Crookwood, Devizes. Mar.  
 745 **R. N. & H. C.**—F. DAVIS, Woolashill, Pershore.  
 746 **H. C.**—F. DAVIS. 747 **Com.**—T. F. HORSLEY.

**Class 270.**—*Pekin Ducklings.* [7 entries, none absent.]

- 749 **I.** (£2.)—THOMAS ALLEN, Crookwood, Devizes. Mar.  
 752 **II.** (£1) and 753 **III.** (10s.)—F. DAVIS, Woolashill, Pershore.  
 750 **R. N.**—THOMAS ALLEN, Crookwood, Devizes. 755 **Com.**—G. T. WHITFIELD.

## Any Other Useful Breeds.

**Class 271.**—*Drakes.* [4 entries, none absent.]

- 756 **I.** (£2.)—MRS. BAYLDON, Oaklands, Dawlish (Cayuga).  
 759 **II.** (£1.)—LADY WILSON, Chillingham Barns, Belford (Cayuga). 1890.  
 757 **III.** (10s.)—F. DAVIS, Woolashill, Pershore (Cayuga).  
 758 **R. N.**—T. H. STRINGER, Bunce Court, Otterden, Kent (Musck). Feb. 5, 1889.

**Class 272.**—*Ducks.* [2 entries.]

- 760 **I.** (£2.)—F. DAVIS, Woolashill, Pershore (Cayuga).  
 761 **II.** (£1.)—LADY WILSON, Chillingham Barns, Belford (Cayuga). 1890.

**Class 273.**—*Young Drakes.* [1 entry.]

762 II. (£1.)—F. DAVIS, Woolashill, Pershore (Cayuga).

**Class 274.**—*Ducklings.* [1 entry.]

763 II. (£1.)—F. DAVIS, Woolashill, Pershore (Cayuga).

**Table Ducks.****Class 275.**—*Pair of Ducklings of 1891, of any Pure Breed.*  
[5 entries, 1 absent.]

767 I. (£2.)—H. G. WESTON, Aylesbury, Bucks (Aylesbury).

766 II. (£1.)—MRS. SCOPY, Sinnington, Pickering, Yorks (Aylesbury). Apr. 20.

768 III. (10s.)—G. T. WHITFIELD, Colebridge, Gloucester (Pekin). Mar. 16.

765 H. C.—MRS. MITCHELL, Elmdene, Kenilworth (Aylesbury). Mar. 24.

**Class 276.**—*Pair of Ducklings of 1891, of a First Cross from any Pure Breeds.* [6 entries, 1 absent.]

774 I. (£2.)—G. T. WHITFIELD, Colebridge, Glos. (Pekin &amp; Aylesbury). Mar. 25.

773 II. (£1.)—H. G. WESTON, Aylesbury (Pekin &amp; Aylesbury).

772 III. (10s.)—MRS. STANYFORTH, Kirk Hammerton Hall, York (Rouen &amp; Pekin). Apr. 1.

**Geese.****Class 277.**—*Ganders.* [6 entries, 2 absent.]

778 I. (£2.)—JOHN KERR, Red Hall, Wigton (Toulouse). 1888.

775 II. (£1.)—R. &amp; H. ABBOT, Hingham, Norfolk (Emden). 1889.

780 III. (10s.)—S. SUTCLIFFE, St. Cross, Winchester (Toulouse). June 20.

779 R. N.—J. H. PEACE, Northfield, Knowle, Warwick (Toulouse).

**Class 278.**—*Geese.* [3 entries, 2 absent.]

783 III. (10s.)—J. H. PEACE, Northfield, Knowle, Warwick (Toulouse).

**Turkeys.****Class 279.**—*Turkey Cocks.* [9 entries, none absent.]

788 I. (£2.)—E. KENDRICK, JUN., Wexford House, Lichfield (American Bronze).

784 II. (£1.)—ABBOT BROS., Hingham, Norfolk (American Bronze). 1890.

787 III. (10s.)—H. T. GOODENOUGH, Ronkswood House, Worcester (American Mammoth). May 24, 1889.

792 R. N. &amp; H. C.—LADY WILSON (Bronze Cambridge). 1889.

H. C.—J. W. LILL for No. 789; MRS. MITCHELL for No. 790.

Com.—J. DONALD for No. 786.

**Class 280.**—*Turkey Hens.* [8 entries, none absent.]

795 I. (£2.)—H. T. GOODENOUGH, Ronkswood House, Worcester (American Mammoth). May 24, 1889.

799 II. (£1.)—LADY WILSON, Chillingham Barns (Bronze Cambridge). 1889.

798 III. (10s.)—MRS. WARD, Bearnett House, Wolverhampton (Bronze).

800 R. N. &amp; H. C.—LADY WILSON (Bronze Cambridge). 1889.

796 H. C.—E. KENDRICK, JUN., Lichfield (American Bronze).



# FARM AND DAIRY PRODUCE OF THE UNITED KINGDOM.

## Cheese.

**Class 281.**—*Three Cheddar Cheeses, not less than 50 lb. each, made in 1891. [7 entries.]*

- 5 I. (£15.)—COX & HALL, Manor Dairy, Wroughton, Swindon.
- 7 II. (£10.)—S. J. MARTIN, Waddon Farm, Lamyatt, Evercreech, Bath.
- 4 III. (£5.)—H. CANNON, Milton Clevedon, Evercreech, Bath.
- 6 R. N.—WM. GILMAN, Cheese Factory, Rocester, Staffs.

**Class 282.**—*Three Cheshire Cheeses, not less than 40 lb. each, made in 1891. [10 entries.]*

- 13 I. (£15.)—WM. DUTTON, Brindley Hall, Nantwich.
- 15 II. (£10.)—T. HOULBROOKE, Calverley Farm, Tarporley.
- 9 III. (£5.)—I. A. BROWN, Ridley Hall, Tarporley.
- 16 R. N. & Com.—R. MULLOCK, Guy Lane Farm, Waverton, Chester.

**Class 283.**—*Six Stilton Cheeses, of 1891 make. [6 entries.]*

- 19 I. (£15.)—MRS. FAIRBROTHER, Beeby, Leicester.
- 21 II. (£10.)—H. MORRIS, Manor Farm, Saxelby, Melton Mowbray.
- 20 III. (£5.)—ALBERT HULL, Frisby House, Billesdon, Leicestershire.
- 18 R. N. & Com.—JOHN BAKER, Willoughby-on-the-Wolds, Loughborough.

**Class 284.**—*Three Cotherstone Cheeses, made in 1891. [2 entries.]*

- 24 II. (£5.)—THOMAS BROWN, Marske, Richmond, Yorks.
- 25 III. (£3.)—MRS. WALTON, Oak Villa, Cotherstone, *via* Darlington.

**Class 285.**—*Three Wensleydale Cheeses, made in 1891. [6 entries.]*

- 26 II. (£5.)—T. BROWN, Marske, Richmond, Yorks.
- 28 III. (£3.)—T. F. KING, Edgley, West Witton, Bedale.
- 29 R. N.—J. PICKARD, Thoresby, Redmire, Bedale.

**Class 286.**—*Three Cheeses of any other British make, made in 1891. [16 entries.]*

- 35 I. (£15.)—H. CANNON, Milton Clevedon, Evercreech, Bath.
- 36 II. (£10.)—COX & HALL, Manor Dairy, Wroughton, Swindon.
- 44 III. (£5.)—R. MULLOCK, Guy Lane Farm, Waverton, Chester.
- 33 IV. (£3.)—I. A. BROWN, Ridley Hall, Tarporley.
- 43 R. N. & Com.—S. J. MARTIN, Waddon Farm, Lamyatt, Evercreech, Bath.

## Soft Cheese.

**Class 287.**—*Three Cream Cheeses. [7 entries.]*

- 48 I. (£3.)—E. BROUGH, Wyndyate, near Scarborough.
- 52 II. (£2.)—C. C. TUDWAY, The Cedars, Wells, Somersct.
- 51 III. (£1.)—T. J. OTHER, Howgrave, Ripon.
- 50 R. N.—E. FLANDERS, 84, Regent Street, Derby.

**Class 288.**—*Three British Soft Cheeses, other than Cream, made from Milk, no extra Cream added.* [2 entries.]

- 56 II. (£2.)—C. R. VALENTINE, Dun Cow Dairy Farm, Ludlow, Salop.  
55 III. (£1.)—C. C. TUDWAY, The Cedars, Wells, Somerset.

## Butter.

**Class 289.**—*Three pounds Fresh Butter, absolutely free from salt, made up in pounds.* [75 entries.]

CLASSES 289 AND 290.

Five equal Prizes of £5 each. Five equal Prizes of £3 each.

- 65 (£5.)—JAMES BLYTH, Wood House, Stansted, Essex.  
73 (£5.)—G. C. CORNER, Murkey Hill, Middleton Tyas, Richmond, Yorks.  
96 (£5.)—REV. J. G. B. KNIGHT, Middleham Rectory, Yorks.  
98 (£5.)—THE EARL OF LONDESBOROUGH, Londesborough Park, Yorks.  
119 (£5.)—LIEUT.-COL. LIONEL TILLOTSON, Silkmore, Stafford.  
90 (£3.)—MRS. HOPWOOD, Ketton Hall, Stamford.  
108 (£3.)—FRED. C. PAINE, Hengrave, Bury St. Edmunds.  
127 (£3.)—WM. WHISTON, Blakelow Dairy, Macclesfield.  
128 (£3.)—REV. S. H. WILLIAMS, Gt. Linford Rectory, Newport Pagnell.  
130 (£3.)—WM. WINTER, Highberries, Carlisle.  
116 **R. N. & H. C.**—MRS. STANYFORTH, Kirk Hammerton Hall, York.  
**H. C.**—F. ALEXANDER for No. 58; CATHEDRAL DAIRY Co. for No. 70; THE COUNTESS OF CRAWFORD for No. 74; MRS. DUTTON for No. 78; J. HANSON for No. 87; D. LONGWILL for No. 99; LIEUT.-COL. RAMSDEN for No. 112; MRS. ROWBOTTOM for No. 115.  
**Com.**—J. BRUTTON for No. 68; J. CARTER for No. 69; W. CHRISTIE-MILLER for No. 72; CAPT. GREENWOOD for No. 85; HON. MRS. CECIL HOWARD for No. 92; MISS A. H. ILLINGWORTH for No. 94; J. F. LAYCOCK for No. 97; MRS. SWAN for No. 117.

**Class 290.**—*Three pounds Fresh Butter, slightly salted, made up in pounds.* [92 entries.]

- 141 (£5.)—JAMES BLYTH, Wood House, Stansted, Essex.  
153 (£5.)—G. C. CORNER, Murkey Hill, Middleton Tyas, Richmond, Yorks.  
177 (£5.)—MRS. HOWELL, Ethy, Lostwithiel, Cornwall.  
182 (£5.)—REV. J. G. B. KNIGHT, Middleham Rectory, Yorks.  
188 (£5.)—MRS. T. H. MILLER, Singleton Park, Poulton-le-Fylde, Lancs.  
147 (£3.)—THE CATHEDRAL DAIRY Co., Exeter.  
196 (£3.)—JAMES OKELL, Park Farm, Barrow, Cheshire.  
200 (£3.)—JOHN P. PHILLIPS, Penderley Farm, Beaulieu, Hants.  
206 (£3.)—MRS. STANYFORTH, Kirk Hammerton Hall, York.  
222 (£3.)—WM. WINTER, Highberries, Carlisle.  
145 **R. N. & H. C.**—JOSEPH BRUTTON, 7, Princes Street, Yeovil.  
**H. C.**—T. ALLAN for No. 136; MISS E. J. BODY for No. 142; J. CARTER for No. 146; MRS. DUCKITT for No. 160; MRS. GOSTLING-MURRAY for No. 166; MRS. HOPWOOD for No. 174; HON. MRS. CECIL HOWARD for No. 176; MISS S. LEGGOTT for No. 184; THE EARL OF LONDESBOROUGH for No. 185; D. LONGWILL for No. 186; J. MILNTHORPE for No. 190; F. C. PAINE for No. 197; GARRETT TAYLOR for No. 209; C. C. TUDWAY for No. 212; WM. WHISTON for No. 218.  
**Com.**—J. CHANNON for No. 148; W. CHRISTIE-MILLER for No. 149; MRS. COLLINGS for No. 152; CAPT. GREENWOOD for No. 169; J. HANSON for No. 170; MISS ILLINGWORTH for No. 179; WM. WORTHINGTON for No. 224.

**Class 291.**—*One Keg or other Package of Salt Butter, not less than 14 lb. in weight.* [21 entries.]

- 229 I. (£5.)—THE CATHEDRAL DAIRY CO., Exeter.  
 230 II. (£3.)—G. C. CORNER, Murkey Hill, Middleton Tyas, Richmond, Yorks.  
 238 III. (£2.)—MRS. EMILY SWAN, Stonefield, Lincoln.  
 239 IV. (£1.)—GARRETT TAYLOR, Trowse House, Norwich.  
 233 R. N. & H. C.—ELLIS POWELL JONES, Plas Llanynys, Denbigh.

---

## CIDER AND PERRY.

**Class 292.**—*Cask of not less than 18, and not more than 30, gallons of Cider, made in the Autumn of 1890.* [9 entries.]

- 252 I. (£5.)—HENRY THOMSON, Southends, Newent, Glos.  
 248 II. (£3.)—W. H. BOTTING, St. Cyres, Exeter.  
 251 III. (£2.)—WM. RENDELL, Netherton Manor, Newton Abbot.

**Class 293.**—*One Dozen Bottles of Cider, made in the Autumn of 1890.* [12 entries.]

- 262 I. (£5.)—H. THOMSON, Southends, Newent, Glos.  
 266 II. (£3.)—JOHN WATKINS, Pomona Farm, Withington, Hereford.  
 259 III. (£2.)—EDWIN PALMER, West Clyst, Exeter.

**Class 294.**—*One Dozen Bottles of Cider, made in any year before 1890.* [7 entries. No award.]

**Class 295.**—*One Dozen Bottles of Perry.* [4 entries.]

- 277 I. (£5.)—JOHN WATKINS, Pomona Farm, Withington, Hereford.  
 276 II. (£3.)—D. PHELPS, Tibberton, Gloucester.  
 274 III. (£2.)—JOHN BOSLEY, Lower Lyde Farm, Hereford.

---

## JAMS AND PRESERVED FRUITS.

**Class 296.**—*Collection of Whole Fruit Jams.* [2 entries.]

- 278 I. (£5.)—JONAS SAVILLE & SONS, 11, Worthington Street, Bradford.  
 279 II. (£3.)—T. G. TICKLER, N. Lincs. Fruit Preserving Works, Grimsby.

**Class 297.**—*Collection of Bottled Fruits.* [2 entries.]

- 281 I. (£5.)—THE WORCESTERSHIRE PRESERVING CO., LTD., Evesham.  
 280 II. (£3.)—T. G. TICKLER, N. Lincs. Fruit Preserving Works, Grimsby.

**Class 298.**—*Collection of Preserved Fruits.* [No entry.]

**Class 299.**—*Collection of Dried or Evaporated Fruits.* [No entry.]

---

HIVES, HONEY, AND BEE APPLIANCES.<sup>1</sup>**Class 300.**—*Collection of Hives and Appliances.* [7 entries.]

283 I. (£5.)—G. NEIGHBOUR &amp; SON, 127, High Holborn, London, W.C.

285 II. (£2 10s.)—W. DIXON, 5, Beckett Street, Leeds.

**Class 301.**—*Observatory Hive stocked with Bees and Queen.*  
[7 entries.]

293 I. (£1.)—G. NEIGHBOUR &amp; SON, 127, High Holborn, W.C. Price £7.

294 II. (15s.)—W. DIXON, 5, Beckett Street, Leeds. Price £4 5s.

292 III. (10s.)—E. C. WALTON, Muskham, Newark. Price £5.

**Class 302.**—*Frame-hive for General Use, unpainted.* [10 entries.]

297 I. (£1.)—G. NEIGHBOUR &amp; SON, 127, High Holborn, W.C. Price £1 4s.

305 II. (15s.)—C. REDSHAW, South Wigston, Leicester. Price £1 4s.

304 III. (10s.)—C. REDSHAW, South Wigston, Leicester. Price £1.

298 H. C.—G. NEIGHBOUR &amp; SON, 127, High Holborn, W.C. Price £1 5s.

**Class 303.**—*Most Complete and Inexpensive Frame-hive for Cottager's use.* [11 entries.]

313 I. (£1.) and 314 II. (15s.)—C. REDSHAW, South Wigston, Leicester. Price 10s. 6d. &amp; 12s. 6d. respectively.

309 III. (10s.)—W. P. MEADOWS, Syston, Leicester. Price 15s.

H. C.—G. NEIGHBOUR &amp; SON for No. 308. Price 12s.; A. C. JEMIESON for No. 310. Price 10s. 6d.

**Class 304.**—*Honey Extractor.* [4 entries.]

318 I. (15s.)—W. P. MEADOWS, Syston, Leicester. Raynor Extractor with patent backing. Price £1 10s.

317 II. (10s.)—G. NEIGHBOUR &amp; SON, 127, High Holborn, W.C. Price £1 15s.

319 H. C.—T. LOWTHE, Rischolme, Lincoln, for the "Unique." Price 21s.

**Class 305.**—*Pair of Section Racks, completely fitted for use and interchangeable.* [8 entries.]

322 I. (15s.)—G. NEIGHBOUR &amp; SON, 127, High Holborn, W.C. Price 8s. 6d.

328 II. (10s.)—C. REDSHAW, South Wigston, Leicester. Price, per pair, 7s.

323 H. C.—G. NEIGHBOUR &amp; SON. Price 7s.

**Class 306.**—*Rapid Feeder.* [6 entries.]

334 I. (10s.)—C. REDSHAW, South Wigston, Leicester. Price 3s.

330 II. (5s.)—G. NEIGHBOUR &amp; SON, 127, High Holborn, W.C. Tin-lined Feeder. Price 6s. 6d.

**Class 307.**—*Twelve Sections of Comb Honey.* [20 entries.]

346 I. (£1.)—SELLS &amp; SON, Uffington, Stamford.

349 II. (10s.)—W. WOODLEY, World's End, Newbury.

353 III. (5s.)—W. CHRISTIE-MILLER, Broomfield, Chelmsford.

<sup>1</sup> Prizes given by the British Bee-Keepers' Association.

**Class 308.**—*Six Sections of Comb Honey.* [18 entries.]

- 366 I. (£1.)—J. GREENHILL, 11, Gramburn Road, Wimbledon.  
 368 II. (10s.)—W. WOODLEY, World's End, Newbury.  
 372 III. (5s.)—W. CHRISTIE-MILLER, Broomfield, Chelmsford.

**Class 309.**—*Run or Extracted Honey, in jars not exceeding 2 lb. each.*  
[17 entries.]

- 378 I. (£1 10s.)—A. J. CARTER, Newfields, Billinghamurst.  
 373 II. (£1.)—CAPT. ST. G. ORD, Farnham House, Bury St. Edmunds.  
 387 III. (10s.)—C. T. OVERTON, Crawley, Sussex.

**Class 310.**—*Granulated Honey, in jars not exceeding 2 lb. each.*  
[8 entries.]

- 390 I. (£1.)—CAPT. ST. G. ORD, Farnham House, Bury St. Edmunds.  
 394 II. (10s.)—W. DIXON, 5, Beckett Street, Leeds.  
 397 III. (5s.)—J. T. HARVEYSON, Lichfield Grove, Finchley.

**Class 311.**—*Best and most Attractive Display of Honey, in any form.*  
[9 entries.]

- 400 I. (£2 10s.)—W. DIXON, 5, Beckett Street, Leeds.  
 399 II. (£1 10s.)—MISS COOPER, St. Nicholas Square, Leicester.

**Class 312.**—*Useful Inventions Introduced since 1889.* [15 entries.]**Silver Medal of British Bee-Keepers' Association.**

- 409 G. NEIGHBOUR & SON, 127, High Holborn, W.C.: for Improved Section Crate.  
 411 P. HARBORDT, 50, Gt. Charlotte Street, Liverpool.

**Bronze Medal of British Bee-Keepers' Association.**

- 413 W. P. MEADOWS, Syston, Leicester: for New Registered Frame.

**Certificates of British Bee-Keepers' Association.**

- 412 W. DIXON, 5, Beckett Street, Leeds: for Swarming Arrangements.  
 420 C. REDSHAW, South Wigston, Leicester: for Patent Glass Sections. In Observatory Racks for Skeps, &c. Frame Hives.

**Class 313.**—*Model of a Tent Suitable for Lectures, with Manipulations of Bees, at Agricultural and Horticultural Shows.* [1 entry.]

- 422 (Silver Medal)—P. HARBORDT, 50, Gt. Charlotte Street, Liverpool.

**Class 314.**—*Most Interesting and Instructive Exhibit of any kind connected with Bee-culture not mentioned in the foregoing Classes.*  
[3 entries.]

- 423 II. (10s.)—W. DIXON, 5, Beckett Street, Leeds: for Case of Specimens.

## IMPLEMENTS.

**Class 1.**—*Combined Portable Threshing and Finishing Machines, to be worked by Steam, and adapted to the preparation of corn for market.* [5 entries.]

4152 I. (£100.)—E. FODEN, SONS, & Co., Sandbach.

4142 } Second and Third  
4144 } Prizes equally di- ( £37 10s.)—GIBBONS & ROBINSON, Wantage.  
vided. ( £37 10s.)—W. TASKER & SONS, Andover.

**Class 2.**—*Power Cream Separators.* [5 entries.]

1032 I. (£30.)—R. A. LISTER & Co., Dursley (Alexandra No. 2).

1234 II. (£20.)—DAIRY SUPPLY Co., LIMD., Museum St., W.C. (Reading Royal).

**Class 3.**—*Hand Cream Separators.* [7 entries.]

1239 I. (£20.)—DAIRY SUPPLY Co., LIMD., Museum St., W.C. (Alpha Windsor).

1238 } Second Prize ( £5.)—DAIRY SUPPLY Co., LIMD., Museum St. W.C. (Alpha Baby).

4294 } equally divided ( £5.)—H. C. PETERSEN & Co., Copenhagen (Burmeister & Wain's Size X, No. 1).

**Class 4.**—*Mechanical Milking Machines.* [1 entry.]

(Recommended for further trial.)

## Silver Medals.

Awarded for articles entered as "New Implements for Agricultural or Estate Purposes."

57 W. & T. AVERY, LIMD., Digbeth, Birmingham: for Improved Dial Indicator for Cattle Weighing Machine.

113 J. & H. KEYWORTH & Co., 35, Farleton Street, Liverpool: for "Adriance" Harvester and Rear Discharge Binder, with Low Platform.

609 JAMES COULTAS, Perseverance Iron Works, Grantham: for "Schlor" Patent Manure Distributor.

1239 DAIRY SUPPLY Co., LIMD., Museum St., W.C.: for appliance for increasing separation in Laval Cream Separator.

1325 JOHN GRAY, Stranraer, Wigtown, N.B.: for Mechanical Milking Machine.

## BUTTER-MAKING COMPETITION.

**Class 1.**—*Open to the United Kingdom.* [10 entries.]

9 I. (£6.)—MRS. F. A. MUDD, Slade House, Thornthwaite, Ripley, Yorks.

7 II. (£4.)—MISS ADA FROST, Slater's Bank, Whaley Bridge, Cheshire.

8 III. (£3.)—MRS. C. L. HORTON, Crumley Heath, Little Leigh, Northwich.

5 IV. (£2.)—R. DUNNING, Thorpe Audlin, Pontefract, Yorks.

6 V. (£1.)—MISS E. E. FRITCHLEY, Sweet Home, Austerfield, Bawtry, Yorks.

4 R. N. & H. C.—MRS. FANNY CORNER, Murkey Hill Farm, Richmond, Yorks.

3 Com.—W. A. CHAPPELL, Worleston, Nantwich.

10 Com.—MISS A. C. PERKINS, Oak Dene, Holmwood, Surrey.

**Class 2.**—*Female Members of a Farmer's Family not in Service or Working for Wages.* [13 entries.]

14 I. (£6.)—MISS E. E. FRITCHLEY, Sweet Home, Austerfield, Bawtry, Yorks.

17 II. (£4.)—MRS. C. L. HORTON, Crumley Heath, Little Leigh, Northwich,

- 20 **III.** (£3.)—MRS. F. A. MUDD, Slade House, Thornthwaite, Ripley, Yorks.  
 13 **IV.** (£2.)—MRS. F. CORNER, Murkey Hill Farm, Richmond, Yorks.  
 23 **V.** (£1.)—MISS F. L. PARKER, Austerfield, Bawtry, Yorks.  
 21 **R. N. & H. C.**—MRS. ISABELLA PAINE, Hengrave, Bury St. Edmunds.  
 16 **H. C.**—MRS. A. HOLLAND, Potter Hanworth, Lincoln.  
 11 **Com.**—MISS E. A. CHAPPELL, Mollard's Farm, Gawsworth, Macclesfield.  
 15 **Com.**—MISS LILLIE HANSON, Botham Hall Farm, Longwood, Huddersfield.

**Class 3.**—*Dairymaids in Service who have never won a Prize exceeding 1l. in value at any Competition.* [3 entries.]

- 24 **I.** (£6.)—MISS POLLIE COOPER, Blakelow Dairy, Macclesfield.  
 25 **II.** (£4.)—MISS ELIZABETH HUGHES, Plas Llanynys, Denbigh.  
 26 **III.** (£3.)—MISS JANE TAIT, Kirk Hammerton Hall, York.

**Class 4.**—*Dairymaids residing in the County of York.* [3 entries.]

- 28 **I.** (£6.)—MRS. F. A. MUDD, Slade House, Thornthwaite, Ripley, Yorks.  
 27 **II.** (£4.)—MRS. F. CORNER, Murkey Hill Farm, Middleton Tyas, Richmond.  
 29 **III.** (£3.)—MISS JANE TAIT, Kirk Hammerton Hall, York.

## HORSE-SHOEING COMPETITION.

LIMITED TO SHOEING-SMITHS IN THE COUNTY OF YORK.

**Class 1.**—*Hunters.* [14 entries.]

- 10 **I.** (£6.)—THOMAS LANCASTER, Heath Common, Wakefield.  
 14 **II.** (£4.)—WILLIAM STEWARD, 60, Norfolk Street, Sheffield.  
 9 **III.** (£3.)—THOMAS B. HORNER, Allwoodby Gates, *via* Leeds.  
 11 **IV.** (£2.)—JAMES NORMAN, Smyth Street, Wakefield.  
 13 **V.** (£1.)—WILLIAM STEAD, Slaidburn.  
 3 **H. C.**—ROBERT BELLAMY, 9, Artisan View, Heeley, Sheffield.  
 8 **H. C.**—JOHN BURLEY HORNER, Wigton Moortown, Leeds.

**Class 2.**—*Agricultural Horses.* [12 entries.]

- 23 **I.** (£6.)—BENJAMIN SANDERSON, Northfield, Thorne, Doncaster.  
 17 **II.** (£4.)—JOSEPH F. CHAPPELL, 23, Porter Street, Sheffield.  
 21 **III.** (£3.)—GEORGE ALFRED OADES, Cross Hill, Crowle, Doncaster.  
 15 **IV.** (£2.)—JOHN ROBERT BAKER, Carnaby, Hull.  
 19 **V.** (£1.)—ROBERT HODGSON, Warrengate, Wakefield.  
 24 **H. C.**—THOMAS SIMPSON, Acklam, Middlesbrough.  
 25 **H. C.**—HENRY JOHN WATKINS, 183, Wellgate, Rotherham.

## FARM PRIZE COMPETITION.<sup>2</sup>

FOR THE BEST-MANAGED FARMS IN THE COUNTY OF YORK.

**Class 1.**—*Arable and Grass Farm of 200 acres and upwards, not less than one-half being Arable.* [5 entries.]

- 1 **I.** (£50.)—TEASDALE H. HUTCHINSON, Manor House, Catterick.  
 4 **II.** (£30.)—JOHN ALFRED STAVELEY, The Manor House, North Dalton, Hull.  
 5 **III.** (£20.)—JAMES TOWNEND, Newton, Doncaster.  
 3 **Com.**—SMITH EYRE PARKIN, Melton Brand, Doncaster.

<sup>1</sup> Given by the Worslipful Company of Farriers, in addition to the FREEDOM OF THEIR GUILD.

<sup>2</sup> Prizes given by the Doncaster Local Committee.

**Class 2.**—*Arable and Grass Farm above 100 and not exceeding 200 acres, not less than one-half being Arable.* [2 entries.]

6 I. (£50.)—ANDREW MERRYWEATHER, Whiston, Rotherham.

7 II. (£30.)—JOHN STANLEY, Campsall, Doncaster.

**Class 3.**—*Arable and Grass Farm above 40 and not exceeding 100 acres.* [4 entries.]

10 I. (£50.)—TOM D. STRICKLAND, Carlton Miniott, Thirsk.

11 II. (£30.)—WILLIAM WALSH, Gilstead, Bingley.

8 III. (£20.)—JOSEPH & WM. HINCHCLIFF, Lady Oak Farm, Emley, Wakefield.

The Council have awarded a certificate of distinguished merit, accompanied by a gratuity of £2, to WILLIAM CHISHOLME, for 26 years' faithful service as shepherd on the farm of Mr. Hutchinson at Catterick.

**PRIZES OFFERED BY DONCASTER LOCAL COMMITTEE.**

STOCK, £865; FARMS, £300.

**HORSES.**

Class	Prizes			Class	Prizes		
	1st £	2nd £	3rd £		1st £	2nd £	3rd £
<b>HUNTERS.</b>							
2 Mare or Gelding, up to 15 st., foaled 1885 or 1886 . . . . .	40	20	10	25 Mare or Gelding, above 14 hands, up to 15 st., foaled in 1885, 1886, or 1887 . . . . .	20	10	5
3 Mare or Gelding, up to 12 st., foaled 1885 or 1886 . . . . .	30	10	5	26 Mare or Gelding, above 14 hands, up to 12 st., foaled in 1885, 1886, or 1887 . . . . .	20	10	5
4 Gelding, foaled 1887 . . . . .	40	20	10	27 Filly, foaled in 1888 . . . . .	15	10	5
5 Mare, foaled in 1887 . . . . .	30	15	5	28 Filly, foaled in 1889 . . . . .	15	10	5
6 Gelding, foaled in 1838 . . . . .	20	10	5	<b>PONIES.</b>			
8 Gelding, foaled in 1889 . . . . .	15	10	5	31 Mare or Gelding, above 13 and not over 14 hands . . . . .	10	5	-
10 Colt, foaled in 1830 . . . . .	15	10	5	32 Mare or Gelding, not above 13 hands . . . . .	10	5	-
<b>COACHHORSES.</b>							
12 Stallion, foaled in 1886, 1887, or 1888 . . . . .	20	10	5	<b>HARNESS HORSES AND PONIES.</b>			
13 Stallion, foaled in 1889 . . . . .	20	10	5	33 Mare or Gelding, of any age, above 14 hands . . . . .	15	10	5
14 Mare and Foal . . . . .	20	10	5	34 Mare or Gelding, not above 14 hands . . . . .	15	10	5
15 Gelding, foaled in 1888 . . . . .	15	10	5	<b>AGRICULTURAL HORSES.</b>			
16 Filly, foaled in 1888 . . . . .	15	10	5	54 Gelding, of any breed, foaled in 1887 or 1888 . . . . .	15	10	5
17 Gelding, foaled in 1889 . . . . .	10	5	-	55 Gelding, of any breed, foaled in 1889 . . . . .	15	10	5
18 Filly, foaled in 1889 . . . . .	10	5	-				
<b>HACKNEYS.</b>							
21 Stallion, foaled in 1888 . . . . .	15	10	5				
22 Stallion, foaled in 1889 . . . . .	15	10	5				

**CHAMPION PRIZES.**

Champion and other Prizes offered by various Societies, through the Royal Agricultural Society of England, at the Doncaster Meeting.

**HORSES.**

- HACKNEY HORSE SOCIETY: Best Hackney stallion, and best Hackney mare; Gold Medals value £15 15s. each.
- SHIRE HORSE SOCIETY: Best Shire stallion and best Shire mare or filly; Gold Medals value £15 15s. each.
- CLYDESDALE HORSE SOCIETY: Best Clydesdale stallion and best Clydesdale mare or filly; £25 each.

**CATTLE.**

- SHORTHORN SOCIETY: Best Shorthorn, male and female; Pieces of Plate value £25 each.

- RED POLLED SOCIETY: Best Red Polled animal: £10 10s.

**PIGS.**

- BRITISH BERKSHIRE SOCIETY: Best Berkshire Yearling boar or sow, farrowed before or in 1891: £10.

**Horse-shoeing Competition.**

- THE WORSHIPFUL COMPANY OF FARRIERS: The two first Prizes in both Classes, value £6 each, together with the Freedom of the Guild.



# ROYAL AGRICULTURAL SOCIETY OF ENGLAND.

## Proceedings of the Council.

WEDNESDAY NOVEMBER 4, 1891.

THE EARL OF FEVERSHAM (PRESIDENT) IN THE CHAIR.

### Present:—

*Trustees.*—Earl Cathcart, Mr. John Dent Dent, Lord Egerton of Tatton, Colonel Sir Nigel Kingscote, K.C.B., Sir A. K. Macdonald, Bart.

*Vice-Presidents.*—Mr. H. Chandos-Pole-Gell, Mr. Walter Gilbey, Lord Moreton.

*Other Members of Council.*—Mr. G. M. Allender, Mr. J. H. Arkwright, Mr. Alfred Ashworth, Mr. Joseph Beach, Mr. J. A. Caird, Mr. Charles Clay, Earl of Coventry, Mr. Percy E. Crutchley, Lieut.-Col. J. F. Curtis-Hayward, Alfred Darby, Mr. William Frankish, Mr. Neville Grenville, Mr. Anthony Hamond, Mr. C. S. Mainwaring, Mr. Joseph Martin, Mr. T. H. Miller, Hon. Cecil T. Parker, Mr. Albert Pell, Mr. Daniel Pidgeon, Mr. James Rawlence, Mr. G. H. Sanday, Mr. A. J. Smith, Mr. Henry Smith, Marquis of Stafford, Mr. E. W. Stanyforth, Mr. Martin J. Sutton, Mr. Garrett Taylor, Mr. J. P. Terry, Mr. John Tremayne, Mr. R. A. Warren, Mr. E. V. V. Wheeler, Mr. C. W. Wilson, Sir Jacob Wilson.

*Officers.*—Mr. Ernest Clarke, Secretary and Editor; Dr. J. Augustus Voelcker, Consulting Chemist; Professor J. Beart Simonds, Consulting Veterinary Surgeon; Mr. Wilson Bennison, Surveyor.

The following members of the Warwick Local Committee were also present:—Lord Brooke, M.P., Lord Ernest Seymour, the Mayor of War-

wick (Mr. J. W. Mann), the Town Clerk of Warwick (Mr. Brabazon Campbell), Major Fosbery, Mr. J. W. Margetts, Mr. T. H. G. Newton, and Mr. Frederick H. Moore (Secretary of the Local Committee).

### Apologies for Non-Attendance.

Apologies for non-attendance were read from the Duke of Richmond and Gordon, K.G., the Earl of Ravensworth, Viscount Emlyn, Sir John Thorold, Bart., and Mr. Faunce De Laune, in consequence of other engagements; and from Mr. Stratton and Mr C. Whitehead, in consequence of ill-health.

### The Fire at Sandringham House.

The minutes of the last monthly meeting of the Council, held on July 29, having been read and approved,

Mr. DENT, as perhaps the oldest member of the Council present, asked permission to intervene in order to request the President to express to their colleague, His Royal Highness the Prince of Wales, the deep sympathy of the Council on the occasion of the late fire at Sandringham. All those who had had the honour, with himself, of receiving His Royal Highness's gracious hospitality at the time of the Norwich Show, carried away with them when they left, not only the happiest remembrances of the kindness of the Prince, of the Princess, and of their daughters, but also the feeling that they had been staying at what they might call a model

in which they were doing practical good. He hoped the Society would see their way to continue the grant, at all events for another year.

Mr. DENT said he must enter his protest against this matter being sprung upon them without notice. It was a most irregular proceeding, involving the suspension of the bye-laws, which did not allow them to make a grant of this character without notice. No notice had been given to any member of the Council of the resolution now proposed. Until he came into the room a quarter of an hour ago, he had no idea that the matter was going to be brought forward again. Precisely the same thing happened last year, and he protested against matters of this kind being brought before the Council without proper notice being given to every member.

Sir JACOB WILSON said that the best answer he could give to Mr. Dent was that the Royal Commission only sat on Monday last, and that their letter was written immediately afterwards. They would remember that last year a resolution was carried by thirty-one votes to two in favour of making the grant, on condition that the Royal Commission should bear all the expenses beyond the 600*l.* That had been carried out. At that time an effort was being made to induce the Government to augment their grant, and every possible influence had been brought to bear upon the Treasury, but they had declined to increase the grant. He was not prepared to say that those efforts would not be repeated, and perhaps with better success hereafter; but that would not meet the present case, as it was very urgent that, if possible, the prize sheet should go out before December. The fact remained that there was a district in England to which the Society would go next year, but for which the Royal Commission with the funds at their disposal could not provide premiums to thoroughbred stallions. Extensive evidence had been taken by the Commission from the best authorities, and the question was always asked, "What amount ought they to give for each premium?" For every answer which gave 150*l.* as the

amount, at least four gave 200*l.* He well remembered when the matter was first being considered in that Council. They started with the idea of giving 300*l.* for each horse. Eventually the premium was fixed at 200*l.*, as, whilst it was not thought good enough to reward a man by giving him 150*l.* for the services of his horse, 200*l.* was sufficient to tempt him to co-operate in the scheme. This year they had several horses which previously served mares at 10*l.* 10*s.*, that were now serving at the Royal Commission fee of 2*l.* in consequence of being supplemented by this sum. He found that generally those who thought that a smaller sum would suffice were those who were not very much interested in horses personally, or else were wealthy owners of stallions who did not regard the money. The Commission were in the position of not being able to supply stallions for the district which was represented by the Society next year. He thought he might say that they would still make a fresh effort to induce the Treasury to give them a further grant; but, in the meantime, a great and good work was being done, as anyone might see by the report showing the mares served and foals produced. He should be very sorry to see a change in the system, which was working so well throughout the country.

Lord EGERTON OF TATTON did not contest the usefulness of these prizes. He thought it was desirable to have these premium stallions every year; but what they felt there was that, coming from a public body such as the Royal Commission, the matter ought to be dealt with in a formal manner. It was against the bye-laws of their Society that a grant of that amount should be voted without due notice being given, as had already been mentioned. The Government had acknowledged, by the grant they had already given, that they were to a certain extent responsible for the system. It was certain that as long as the money was found by the Society the Treasury would not find it; but if they said that they had a great many other objects in view, the Government, as they had already recognised their responsibility by

finding the larger proportion of the fund, would find the money for the whole. If the Society were held responsible for that part of the country in which they held their Show, the Government and the Treasury were equally responsible for the whole: and, as long as they did not make the Treasury feel that they were responsible, the onus would be thrown upon the Society. There was besides a technical objection on the present occasion; but, whatever course might be adopted, he trusted that it would not form a precedent for the future.

Mr. GILBEY pointed out that in former years, before the present system of giving premiums was started, the Society used often to give prizes of substantial amounts at its annual Meetings for thoroughbred stallions. Everyone connected with the Society, and the writers of all the official reports, had condemned the old system as more or less waste of money. As they did not now give prizes for thoroughbred horses at their summer Shows, the sum of 600*l.*, which they were now asked to vote, was not all an additional expense to the Society.

The PRESIDENT said he should be sorry if the grant were not made. At the same time he recognised the force of the objection raised in regard to the bye-laws, and he thought that if the vote were passed that day, it should be upon the strict understanding that the bye-laws should be observed in the future.

After some further discussion, a motion by Sir JACOB WILSON (seconded by the EARL of COVENTRY) for the suspension of Bye-law 41, was carried, and Lord Coventry's motion for the grant of 600*l.* was passed *nem. dis.*

#### House.

Sir NIGEL KINGSCOTE (Chairman) reported that during the recess the cleaning of the general offices and various other repairs of the building sanctioned by the Council had been completed to the satisfaction of the Surveyor. Various accounts for repairs and office requirements had been submitted and passed.

#### Journal.

Earl CATHCART (Chairman) reported that Part III. of Vol. II. (third series) of the Journal had been

published on September 30, and duly issued to the members. The Committee recommended the payment of various amounts in respect of literary contributions to and the printing of this number. The Secretary had reported the issue during the recess (1) of the reprint as a sixpenny pamphlet of Mr. Whitehead's paper in the June Journal on "Methods of Preventing and Checking the Attacks of Insects and Fungi," and (2) of a second edition of Prof. Brown's pamphlet on "The Structure of the Horse's Foot." Various works on agriculture which had been purchased for the Library during the recess were laid upon the table. The Committee reported that twenty-six entries had been received for the farm prizes offered by the Warwick Local Committee. They recommended that two Judges be appointed to award the prizes, and that two visits of inspection be made: one about January, and the other shortly before the Show. The Committee had considered the proposed articles to appear in the next number of the Journal, and had given directions thereon. A suggestion by Mr. Frank Proctor, C.E., for a paper on Steam Digging had not been adopted.

#### Chemical.

Mr. R. A. WARREN reported that Dr. J. W. Leather had tendered his resignation of the post of Senior Assistant in the Laboratory, consequent upon his election to the Professorship of Chemistry in the Harris Institute, Preston. The Committee had accepted with regret Dr. Leather's resignation, and expressed to him their appreciation of the services that he had rendered the Society during the last five years. The Council were aware that an action had for some time been pending, in which Mr. James Snowsell sued the Society for damages in respect of a report presented by the Chemical Committee on July 30, 1890, and published in the Society's Journal. The case came on for trial on Friday last, October 30, and was withdrawn on the terms stated by Counsel. An account of the proceedings was laid before the Council, and the Committee recommended that it be printed as a separate report (see page 820).

**Seeds and Plant Diseases.**

The PRESIDENT then said that before the report of the Seeds and Plants Committee was brought up, he desired to make a short statement to the Council. It would be in their recollection that a resolution was passed at their last meeting on July 29, urging the Board of Agriculture to make an inquiry into the ravages of the Diamond-back Moth, and promising any assistance which the Society and its officials could afford in making such inquiry. That resolution was passed, he need not say, in all good faith, no difficulty being anticipated in carrying it into effect. Miss Ormerod, however, declined to co-operate in the inquiry, basing her objection on the ground that by the terms of her appointment she was not under obligation to do so. They must admit that the resolution, so far as Miss Ormerod was concerned, was *ultra vires*: but she had in the past been so ready and anxious to comply with the wishes of the Council that they could not have foreseen the objection which she raised. Miss Ormerod, under a misapprehension as to the intentions of the Council in passing the resolution, thought it necessary to send in her resignation. He felt sure that the Council would not desire that their association with one for whom they entertained such great respect, and who had rendered such valuable services to the Society, should be severed on account of this difficulty. (Hear, hear.) The Secretary, with his (Lord Feversham's) full consent, had therefore endeavoured to remove the misapprehension, and, he was happy to say, with success. A settlement which was, he thought, honourable to all parties had been arrived at, and the Seeds and Plants Committee would bring up a recommendation on the subject, which he hoped might receive the unanimous approval of the Council, and would put matters on a sound and satisfactory footing for the future. (Hear, hear.)

Mr. MAINWARING said that he had been asked to take the chair at the meeting of the Seeds and Plants Committee, held on the previous day, in consequence of the unavoidable absence of Mr. Whitehead, through con-

tinued illness. He was sure he was only expressing the general feeling of the Council in hoping that Mr. Whitehead might soon be restored to his usual health. (Hear, hear.) The Secretary had submitted a correspondence which he had had with Miss Ormerod as to the resignation which she had desired to tender of her post of Consulting Entomologist. At the request of the President, the Committee had given careful consideration to the conditions under which Miss Ormerod was willing, if desired by the Council, to resume her association with the Society, and they recommended that the original arrangement made with Miss Ormerod in 1882 be reverted to, and that she be reappointed as Honorary Consulting Entomologist, substantially on the same conditions as at the outset.

The adoption of the report of the Seeds and Plants Committee was then put from the chair, and carried unanimously. Mr. Frankish was added to the Committee.

The SECRETARY read a letter, dated November 2, which he had received from Miss Ormerod, stating that she would feel herself honoured by re-association with the Society, and that she fully authorised him to accept such re-association on her part, if the Society thought fit to desire it.<sup>1</sup>

<sup>1</sup> The following is a copy of Miss Ormerod's letter subsequently received, dated November 7, 1891:—

DEAR SIR,—I have learned with much gratification of the desire of the Council that I should resume association with the Royal Agricultural Society as its Honorary Consulting Entomologist.

I therefore beg to signify to yourself as Secretary my acceptance of the office on the terms and conditions laid down in the minutes of the Seeds and Plants Committee, dated the 3rd instant.

To my formal acceptance I beg to be allowed respectfully to add the expression of my great satisfaction in being reunited with the Society, and with the expression also of my own deep regret for anything on my part which through misapprehension or want of knowledge of business has added to the temporary difficulty, I beg to offer my cordial and sincere thanks for the friendly and kind consideration shown me in the arrangements of my re-association.

I am, dear Sir, yours very truly,  
(Signed) ELEANOR A. ORMEROD,  
Honorary Consulting Entomologist  
of the Royal Agricultural Society  
of England.

Ernest Clarke, Esq.  
Secretary of the  
Royal Agricultural Society.

**Veterinary.**

The Hon. CECIL T. PARKER said that various letters as to liver fluke in sheep had been received; and, as Professor Simonds's pamphlet on "The Rot in Sheep" had long been out of print, the Committee recommended that inquirers should be referred to the articles on the subject which have from time to time appeared in the Society's Journal.

For the Horse-Shoeing Competition at the Warwick Meeting next year, the Committee recommended that five prizes of 6*l.*, 4*l.*, 3*l.*, 2*l.* and 1*l.* respectively, be offered in each of two classes, viz. for Roadsters and Dray-horses: the competition to be limited to Shoeing-Smiths in the Society's District F, consisting of the counties of Gloucester, Hereford, Monmouth, Salop, Stafford, Worcester, Warwick, and of South Wales. The Committee had discussed and settled the detailed regulations and times of the Competitions, and recommended that they should be incorporated in the prize-sheet as usual. They did not propose the continuance of a class for the exhibition of systems of horse-shoeing not in common use. A letter had been received from Sir Joseph Lister, President of the British Institute of Preventive Medicine, inviting the Council to nominate a representative upon the Council of the Institute. The Committee recommended that the President of the Society for the time being should be appointed a Member of the Council of the British Institute of Preventive Medicine, in accordance with No. 8 of the Institute's Articles of Association. The Committee gave notice that at their next meeting they would ask for a grant of 600*l.* for the coming year, of which 500*l.* to be given to the Royal Veterinary College and 100*l.* to be reserved for general purposes.

Professor Brown had presented the following report:—

**PLEURO-PNEUMONIA.**—During the eight weeks ended October 24, there were sixteen fresh outbreaks of this disease in Great Britain, barely one-fifth of the number in the corresponding period of last year. These sixteen outbreaks occurred in the counties of Hants, London, Middlesex, Surrey, and

York (W. R.) in England, and Midlothian in Scotland; eighty-two cattle affected with the disease and 876 healthy cattle which had been exposed to the risk of infection were slaughtered by order of the Board of Agriculture. Besides the cattle slaughtered in these genuine outbreaks of the disease, thirty-seven suspected animals were slaughtered and found free from pleuro-pneumonia, but affected with other diseases. In Ireland during the eight weeks there were nineteen outbreaks: twenty-two cattle affected with the disease, 762 healthy cattle in contact, and eleven suspected cattle were slaughtered.

**ANTHRAX.**—There were thirty-three outbreaks of anthrax reported in Great Britain in the eight weeks; they occurred in the counties of Cumberland, Derby, Gloucester, Lancaster, Leicester, Lincoln (Holland), Notts, Somerset, Sussex (East), Warwick, Wilts, and York (W. R.), in England; and Aberdeen, Banff, Kirkcudbright, Linlithgow, and Perth, in Scotland. In these outbreaks forty-one animals were attacked, three diseased animals were killed, thirty-three died, and one recovered.

**SWINE FEVER.**—There were 793 fresh outbreaks of swine fever reported in Great Britain during the eight weeks, 4,556 swine were attacked, 1,757 diseased pigs were killed, 2,027 died, 618 recovered, and 564 remained alive when the last published return was made up.

**RABIES.**—Only five cases of this disease were reported in eight weeks; they occurred in the counties of Essex, Herts, Lancaster, and Surrey.

**ABORTION IN CATTLE.**—On the subject of abortion several inquiries have been undertaken in different parts of the country. In some cases the unsanitary conditions of the farm have afforded an explanation of the occurrence of abortion; but generally there have not been any circumstances to which special importance could be attached as possible causes. In one instance only the history of the herd supported M. Nocard's theory of the contagious

character of the disorder. The subject will form part of the next annual report from the Royal Veterinary College.

**LIVER FLUKE IN SHEEP, &C.—** Liver rot, or fluke disease, has existed in some districts since the heavy rainfall, but the time has passed for any extensive outbreak of the disease to occur. It may, however, be well to advise flockmasters to take the precaution to supply sheep, especially breeding ewes, with artificial food mixed with salt, a sprinkling of which over each ration will be grateful to the animals, and may to some extent arrest the invasion of the parasites. Investigations in reference to the origin of the lung worm, and also as to the contagious nature of foot-rot in sheep, have been continued during the year, and will be dealt with in the annual report of the College.

#### **Pleuro-Pneumonia.**

Mr. DENT hoped that Professor Brown would have been there that morning, because he had asked him yesterday whether he would favour them with information as to the result of the year's work with regard to pleuro-pneumonia. The report of the Veterinary Department for 1890 did not come out until September, and then it contained the proceedings for only four months of last year. No doubt he could obtain an idea of the figures by hunting up the monthly reports which had been presented to the Veterinary Committee; but he had hoped that they might have had the particulars that day. It was only fair to the public and to men, who, like himself, did not exactly agree with the policy of the Board, that the figures relating to the slaughter of animals should be made known.

#### **Abortion in Cattle.**

He (Mr. Dent) was sorry to find that the veterinary professors and the veterinary surgeons were not inclined to go into this question of abortion in cattle. They said that everything was known about it. He could not believe that everything was known either of this disease or of any other. A friend of his had had

something like sixteen cases of abortion in a small herd. He thought the veterinary professors ought to show a little more interest in a subject which was of so much importance to the agricultural community. He was not at all satisfied with the suggestions they made on the subject.

Colonel CURTIS-HAYWARD said he quite agreed with Mr. Dent as to the subject of abortion in cattle. He thought they knew very little about it. In the part of the country in which he lived (Gloucestershire), some interesting inquiries had been made by a gentleman, who had asked for all cases of abortion in cattle to be reported to him. He had found that at one farm at which abortion occurred, the whole of the herd was disposed of, and a fresh lot of animals were brought upon the farm, notwithstanding which abortion again occurred upon that farm. Previously, there had never been abortion upon the farm until it was unlet for about a year, when cattle were allowed in on tack. During that time animals aborted. That seemed to lead to the idea that abortion got upon the herbage. He did not believe that it was ergot, yet it appeared to get upon the herbage in some way or other. It was generally considered a certain cure to get rid of the whole herd. But here was a case in which the whole herd was disposed of and yet abortion again appeared in the fresh herd.

Mr. A. J. SMITH asked whether the same bull was used for both herds.

Colonel CURTIS-HAYWARD: No, the herd was entirely changed.

#### **Stock Prizes.**

Mr. SANDAY (Chairman) said that as the Council of the Shire-horse Society had decided that Mr. Peter Blundell's stallion "Prince Harold," to which the third prize was awarded in Class 37 at the Doncaster Meeting, was ineligible for their stud-book, the animal was disqualified under Regulation 45, and they therefore recommended that the third prize in Class 37 be awarded to the reserve number, Messrs. Lowndes and Son's "Castern Harold." The third prize sow, No. 2,060, in Class 165, Mr. Arthur E.

Dyson's "Cestrian Princess," had failed to comply with the regulations, and was therefore disqualified from receiving the prize. The Committee recommended that the third prize of 3*l*. be therefore awarded to Mr. Sanders Spencer for "Holywell Rissole" (Reserve Number). Various letters with reference to stock entries had been considered, and directions given thereon. The Committee had arranged a preliminary prize sheet for the Warwick Meeting, which would be printed and sent out to all members of Council before the December meeting, when the Committee would bring up a formal motion for its adoption.

### Implement.

Mr. FRANKISH (Chairman) stated that the report of the Judges on the trials in Scotland of the Mechanical Milking Machine shown at Doncaster (see page 854) had been presented by Mr. Neville Grenville, and that the Committee concurred with the Dairy Committee in recommending that the prize of 20*l*. be awarded to the exhibitor, Mr. John Gray. The further trial of Messrs. J. and H. Keyworth & Co.'s Adriance Harvester and Rear-discharge Binder had been carried out at High Ellers, Doncaster, on August 31, and the Committee endorsed the recommendation by the Judges of the award of a Silver Medal to that implement. The draft prize sheet and regulations for the exhibition of Implements, &c., at the Warwick Meeting, had been considered and approved, and ordered to be issued. The Committee recommended that the Senior Steward of Implements (Mr. Crutchley) and Mr. Joseph Beach be requested to make a selection of land necessary and suitable for the purposes of the trials of Ploughs at Warwick next spring.

### General Warwick.

Mr. DENT reported that the following twenty-six entries had been received for the farm prizes, amounting to 500*l*., offered by the Warwick Local Committee:—

CLASS 1.—For the best managed arable and grass farm of over 250 acres, of which not less than one-

third shall be arable. First Prize, 80*l*.; Second, 40*l*.; Third, 20*l*.

CUBBERLEY, EDWARD A...Moor Hall, Alcester, Redditch.  
GRIMES, W. HOWLETT, JUN...Long Itchington, Rugby.  
HAWKES, JOSEPH...Bearley Grange, Stratford-on-Avon.  
HAWKES, RICHARD J...Newbold Farm, Leamington.  
JAMES, JOHN...Whitchurch Farm, near Stratford-on-Avon.  
LUCAS, EZRA...Home Farm, Baginton, Coventry.  
PALMER, JOHN...Hampton-on-Hill, Warwick.  
THORNLEY, HENRY E...Radford Hall, Leamington.  
TOONE, J. PARKER...High Cross, Lutterworth.

CLASS 2.—For the best managed arable and grass farm of over 150 acres and not exceeding 250 acres, of which not less than one-third shall be arable. First prize, 60*l*.; Second, 40*l*.

BLAKE, E. TUCKER...Park Hall Farm, Salford Priors, Evesham.  
BOURNE, GEORGE...Drakenage Farm, Kingsbury, Tamworth.  
COLES, RICHARD...Offchurch, near Leamington.  
DANEY, PHILIP S...Church Farm, Offchurch, Leamington.  
DENNY, JOSIAH...Budbrook, Warwick.  
DEWHURST, ROBINSON...Shelford House, Burton Hastings, Nuneaton.  
FRANCIS, THOMAS F...Grove Farm, Tachbrook, Leamington.  
PRATT, CHARLES A...Rushford, Evesham.  
FERVE, JOHN R...Lillington, Leamington.  
WHEELER, CHARLES...King Stone Farm, Long Compton, near Chipping Norton.

CLASS 3.—For the best managed arable and grass farm of over 50 acres, and not exceeding 150 acres. First Prize, 40*l*.; Second, 20*l*.

IBBOTSON, ROBERT...The Hawthorns, Knowle, Warwick.  
MEIGH, JOHN EAGLE...Eastern Green, Coventry.  
SANSOME, GEORGE...Salford Farm, Evesham.  
SILL, EDWARD J...Bidford, Stratford-on-Avon.  
SPENCER, ANNA BOLTON, and SAMUEL K...The Mount, Black Hill, Snitterfield, near Stratford-on-Avon.  
THORNTON, CHARLES...Curdworth, near Birmingham.  
WILDAY, LEWIS...Dunton, Minworth, Birmingham.

Various matters of detail connected with the Warwick Meeting had been discussed. The Committee recommended that arrangements be made for a band during the Show week.

### Showyard Works.

Mr. CLAY reported that the whole of the Society's plant at Doncaster had been cleared away and stored under temporary sheds built for that purpose in the Castle Park, Warwick, and that all the old materials had been sold; but in consequence of the very large quantity of timber to be disposed of, only moderate prices had been realised. The Surveyor had presented a complete detailed statement of the cost of the various works in the Showyard, which showed, after deducting the amounts realised by sale of materials and those received from exhibitors, a total cost of 5,924*l.* 1*s.* 2*d.* Four tenders for the supply of timber at Warwick had been received, and the Committee recommended that Messrs. Wade, Sons, and Co.'s tender be accepted. The Committee recommended the acceptance of the following tenders: (1) Messrs. Walter Hill and Co. for the advertising of the Warwick Show; (2) The Bodega Company, for the supply of wines, &c., at the annual Shows in their pavilion; and (3) Messrs. Merryweather and Sons, of Fire Engines at Warwick.

### Selection.

The recommendations of this Committee having been read, Earl CATHCART (Chairman) moved that Mr. J. Marshall Dugdale, of Llwyn, Llanfyllin, *via* Oswestry, be elected a member of Council in the room of Mr. Chandos-Pell-Gell, elected a Vice-President.

Mr. MAINWARING was very glad to second the motion. Mr. Dugdale had for a long time taken an active interest in the agriculture of the district where he lived, and would make a useful member of the Council.

The motion was carried unanimously.

Earl CATHCART gave notice that the Committee proposed at their next meeting to bring up nominations for vacancies now existing in the list of Honorary Members.

### Education.

Mr. PIDGEON reported that arrangements had been made for the Society's Junior Examinations to be

held on the 10th and 11th instant, and that forty-seven candidates had been entered from ten schools. The ten successful candidates at last year's examinations having duly complied with the regulations, the Committee recommended the payment of the scholarships forthwith. The Committee had authorised the supply by Messrs. W. and A. K. Johnston of portfolios for holding sets of the Society's diagrams at a cost not exceeding 9*s.* in cloth or 15*s.* in half-morocco. The Secretary had been authorised to arrange for the next Senior Examination, the date of which was provisionally fixed for May 10 to 14, 1892. The Committee gave notice that at their next meeting they would move for the renewal of their annual grant of 500*l.*

### Dairy.

The Hon. CECIL T. PARKER (Chairman) reported that the Judges had made a further trial of the milking machine entered in Class 4 at Doncaster, and the Committee recommended that the prize of 20*l.* be awarded to Mr. Gray of Stranraer. They recommended that Mr. Stanyforth be added to the Committee.

The Committee had considered the following resolutions passed by the Council of the English Jersey Cattle Society:—

1. That a champion dairy prize of 50*l.* be offered to the Royal Agricultural Society of England, to be awarded for the best dairy cow exhibited at their Show in 1892, subject to a butter test by the churn.

2. That the Royal Agricultural Society be invited to receive a deputation consisting of the President, Viscount Hampden, the Vice-President, Mr. Hugh C. Smith, and the President Elect, Mr. J. F. Hall, from the English Jersey Cattle Society on the subject.

The Committee could not recommend the adoption of the suggestion of the English Jersey Cattle Society, in consequence of the practical difficulties which they foresaw in carrying out a butter-test by the churn, as desired; but they left the Council to decide whether they would receive



the proposed deputation. The Committee had arranged a schedule of prizes for dairy produce, for poultry, and for butter-making competitions, which they had referred to the Stock Prizes Committee for inclusion in the draft prize-sheet for the Warwick Meeting. Letters suggesting that prizes should again be offered for cheeses made in the year previous to the Show had been considered. As the Country Meeting for 1893 would be held in a Dairy District, the Committee recommended that notice be given of the intention of the Council to offer in connection with that Meeting prizes for cheese made in 1892, in addition to prizes for cheese made in 1893. They desired also to give notice of their intention to move that increased prizes for Dairy produce be offered in connection with the Country Meeting of 1893, and that at their next meeting they would move for the renewal of their annual grant of 100*l*.

Sir NIGEL KINGSCOTE said that whilst the Council would be anxious not to appear discourteous, it did not seem to him that any practical advantage would result from the attendance of the deputation, if, as he understood, the Dairy Committee were unanimous in their recommendation.

Mr. MAINWARING supported this view; and the Secretary was instructed to write to the English Jersey Cattle Society saying the Council regretted they could not entertain their offer.

#### **International Agricultural Congress at The Hague.**

On the motion of the Hon. CECIL T. PARKER, seconded by Mr. C. S. MAINWARING, cordial votes of thanks

for assistance rendered during the recent visit of the Society's representatives to Holland were unanimously passed to Her Majesty's Minister at The Hague, the Minister of Waterstaat, the President and Secretary of the Executive Committee of the International Agricultural Congress, the Consul for the Netherlands in London (Mr. H. S. J. Maas), and others.

#### **Country Meeting of 1893.**

Invitations from the Corporations of Chester and Manchester inviting the Society to hold its Country Meeting of 1893 in their respective cities were further considered, and on the motion of the Hon. CECIL T. PARKER, seconded by Mr. GARRETT TAYLOR, the Committee of Selection were instructed to bring up at the next meeting a recommendation as to the appointment of a Committee of Inspection to visit the sites and other accommodation offered by each locality.

#### **Chicago Exhibition, 1893.**

The PRESIDENT reported that he had been requested by the Royal Commission for the British Section of the Chicago Exhibition of 1893 to act as Chairman of a Committee for Agriculture which the Commission were desirous of forming, and he hoped that he should have the assistance of his colleagues on the Council in regard to the questions coming before that Committee.

#### **Date of next Meeting.**

A variety of other matters having been dealt with, the Council adjourned until Wednesday, December 9 next, at noon.

---

## WEDNESDAY, DECEMBER 9, 1891.

## THE EARL OF FEVERSHAM (PRESIDENT) IN THE CHAIR.

**Present:—**

*Trustees.*—H.R.H. the Prince of Wales, K.G., Col. Sir Nigel Kingscote, K.C.B., Sir A. K. Macdonald, Bart., Duke of Richmond and Gordon, K.G.

*Vice-Presidents.*—Mr. H. Chandos-Pole-Gell, Mr. Walter Gilbey, Sir J. H. Thorold, Bart., Mr. Charles Whitehead.

*Other Members of Council.*—Mr. G. M. Allender, Mr. J. H. Arkwright, Mr. Alfred Ashworth, Mr. Joseph Beach, Mr. J. Bowen-Jones, Lord Brougham and Vaux, Mr. J. A. Caird, Mr. Charles Clay, Earl of Coventry, Mr. Percy E. Crutchley, Lieut.-Col. J. F. Curtis-Hayward, Mr. Alfred Darby, Mr. J. Marshall Dugdale, Mr. S. P. Foster, Mr. William Frankish, Mr. Charles Howard, Mr. C. S. Mainwaring, Mr. Joseph Martin, Mr. T. H. Miller, Hon. Cecil T. Parker, Mr. James Rawlence, Mr. Samuel Rowlandson, Mr. G. H. Sanday, Mr. W. T. Scarth, Mr. A. J. Smith, Mr. Henry Smith, Sir Joseph Spearman, Bart., Marquis of Stafford, Mr. E. W. Stanyforth, Mr. Martin J. Sutton, Mr. Garrett Taylor, Mr. John Tremayne, Mr. R. A. Warren, Mr. C. W. Wilson, Sir Jacob Wilson.

*Officers.*—Mr. Ernest Clarke, Secretary and Editor; Dr. J. Augustus Voelcker, Consulting Chemist; Mr. Wilson Bennison, Surveyor.

The following members of the Warwick Local Committee were also present:—the Mayor of Warwick (Mr. J. W. Mann), the Mayor of Leamington (Mr. John D. Barbour), Mr. J. W. Margetts, Mr. T. H. G. Newton, and Mr. Frederick H. Moore (Secretary of the Local Committee).

Apologies for non-attendance were received from H.R.H. Prince Christian of Schleswig-Holstein, K.G., Earl Cathcart, Viscount Emlyn, Lord Moreton, and Mr. John Dent Dent.

The minutes of the last monthly meeting of the Council, held on November 4, having been read and approved,

The PRESIDENT read from Sir Francis Knollys a letter communicating the thanks of His Royal Highness the Prince of Wales for the Council's expression of sympathy on the occasion of the late fire at Sandringham House.

**New Member of Council.**

Mr. MAINWARING, in the regretted absence of Earl Cathcart, Chairman of the Committee of Selection, on account of ill-health, introduced Mr. J. Marshall Dugdale, the newly-elected member of Council, and the PRESIDENT welcomed Mr. Dugdale as one of their number.

**Election of new Governors and Members.**

The election of the following five Governors and ninety-nine Members was then proceeded with:—

*Governors.*

DARTMOUTH, Earl of..Patshull, Wolverhampton.  
NEELD, Sir Algernon W., Bart...Grittleton, Chippenham.  
PORTSMOUTH, Earl of..Hurstbourne Park, Whitechurch, Hants.  
RUTLAND, Duke of, K.G...Belvoir Castle, Grantham.  
SMITH, Hon. W. F. D., M.P...3, Grosvenor Place, S.W.

*Members.*

ARCHER, A. G...Downton, Wilts.  
ATKINS, Thomas H...Solihull Lodge, Shirley, Birmingham.  
BAIRD, J...Knoydart, Isle Ornsay, N.B.  
BALDWIN, S...King's Norton, Birmingham.  
BARLOW, J...Darley, Derbyshire.  
BARRINGTON, R. M...Fassaroo, Bray, co. Wicklow.  
BENNETT, T. H...Cobham Court, Surrey.  
BERNERS, C. H...Woolverstone Park, Ipswich.  
BETHELL, S. W...Wick Ho., Downton.  
BICKNELL, N. L...Gurteen, Shinrone.  
BOURKE, Walter, L...Worsley Old Hall, Manchester.  
BROOME, J...Sunny Hill, Llandudno.  
CHARRINGTON, J. D...Fernside, Wimbledon Common.  
CHRISTY, J. F...Upton, Alresford,

CORNWELL, F. O...25 & 26, Crosby Buildings, E.C.  
 CROFT, F. E...5, Water Lane, E.C.  
 CROFT, J. R...5, Water Lane, E.C.  
 CUBBERLY, E. A...Moor Hall, Alcester.  
 CURTIS, J...9, Old Jewry Chambers, E.C.  
 CUST, B. M...Ellesmere.  
 DALE, T. B...Balderton, Newark.  
 DALTON, R. A...Whoberley Hall, Coventry.  
 DEANE, W. J...Longraigue, co. Wexford.  
 DEWHURST, G. L...Woodleigh, Knutsford.  
 DITMAS, F. B...Downton.  
 DODSWORTH, Sir M. R. S., Bt...Thornton, Watlass, Bedale.  
 DUGDALE, S...Blyth Hall, Coleshill.  
 EVANS, T...Penyrheol Farm, Rumney, Mon.  
 FISHER, H. O...Tymynydd, Radyr, Cardiff.  
 GARRETT, T. R...Manor Farm, Gayden, Warwick.  
 GERY, C. R. W...St. Neot's, Hunts.  
 GOODENOUGH, H. T...Roukswood House, Worcester.  
 GURDON, Sir W. B., K.C.M.G., C.B...Grundisburgh Hall, Woodbridge.  
 HALLWOOD, A...Lower Broughton, Manchester.  
 HAIRSPINE, H. S...8, Halkin St. West, S.W.  
 HAWKSLEY, G. W...Sheffield.  
 HEYTESBURY, Lord...Heytesbury, Wilts.  
 HICKLING, A. W...34, Regent St. Nottingham.  
 HICKS, F. J...Allensmore, New Cross, S.E.  
 HOBSON, G...Harperley Mills, Lutz Green.  
 HOGUE, T. Wilson...Vermont, Bournemouth.  
 HOLLAND, G. A. M...Potter Hanworth, Lincoln.  
 HOLLIDAY, J. F...Ivy Cottage, Knutsford.  
 HOOD, Hon. V. A. Nelson...12, Wimpole St. W.  
 HOPE, J...Mossley Hall, Congleton.  
 HUETT, J. H...25 & 26, Crosby Buildings, E.C.  
 HUTTON, Rev. H. W...Vicars' Court, Lincoln.  
 HUTTON, R...Charlecote, Warwick.  
 INNES, A. C. M...5, Water Lane, E.C.  
 KING, E...Claremont, Ripon.  
 LAMBERT, Vet. Col. J. D., C.B...5 King Street, S.W.  
 LAZAR, Prof. Paul...Budapest, Hungary.  
 LEATHER, J. W., Ph.D...The Harris Institute, Preston.  
 LONG, W. E...Hurts Hall, Saxmundham.  
 LORD, G...Norbury Booths, Knutsford.  
 LOUGH, T...5 Newton Grove, Chiswick.  
 MCCAUSLAND, W...Victoria Street, Belfast.  
 MAGHERAMORNE, Lord...Magheramorne, co. Antrim.  
 MARRIOTT, C. W...Upham, Bishop's Waltham.  
 MEHL, F...Oakleigh, Alderley Edge.  
 NEALE, C...Kneeton, Bingham, Notts.  
 NEEDHAM, G. A...Ripley, Yorks.  
 NICHOLSON, J...Shernden Farm, Edenbridge.  
 NOEL, Col. E. A...Outwoods, Derby.  
 NORMANBY, Rev. the Marquis of...Windsor.  
 OLIPHANT, G. A. J...Rushford, Christchurch, Hants.  
 OSBORNE, F. B...Chipping Campden, Glos.  
 PARKER, Rev. Sir W. H., Bt...Melford Hall.  
 PARLANE, W...Rusholme, Manchester.  
 PELL, A. J...Wilburton Manor, Ely.  
 PINKNEY, T...Carr View, Sleights, Yorks.  
 PRINSTEON, Sir H. J., Bart...Beeston Hall, Neatishead, Norwich.  
 PRIOR, R. H...Comer Lodge, Bedford.  
 READER, T...Brenchley, Kent.  
 READING, F...Whitnash, Leamington.  
 READING, W. J. P...Langford, Oxon.  
 REMINGTON, J. S...Ulverstone.  
 ROBSON, C. R...Union Club, S.W.  
 ROOPER, W. O...Roade, Northants.  
 ROSE, W...Ballbrook Ho., Withington.  
 SAMUELSON, E...Bodicote Grange Banbury.

SHARKEY, R...64 Clarendon St., Leamington.  
 SMITH, A. E...Iverley Farm, Staffs.  
 SMITH, D. F...Parham, Wickham Market.  
 STEERE, L. S...Jays, Ockley, Dorking.  
 SYNGE, A. H...Glanmore, co. Wicklow.  
 THORNICROFT, J...Metchley Park, Edgbaston.  
 TOLLEMACHE, Lord...Peckforton, Tarporley.  
 TREVELYAN, Sir W. J., Bt...Nettlecombe Ct.  
 TURNER, G. H...Littleover, Derby.  
 WALKER, C. H...Stonely Hall, St. Neot's.  
 WALLACE, W...Graham Square, Glasgow, N.B.  
 WALLIS, W. L...The Wish, Eastbourne.  
 WATERHOUSE, W...Starborough Castle, Kent.  
 WEATHERBY, E. M...Oatlands Park, Weybridge.  
 WHITWORTH, F...94 & 96 King St., Manchester.  
 WILLIAMS, S...Penybont, Corwen.  
 WRIGHTSON, R. G...Hurworth-on-Tees.  
 YATES, S...The Headlands, Didsbury, Lancs.

The reports of the various Standing Committees were then presented and adopted as below:—

### Finance.

Sir NIGEL KINGSCOTE (Chairman) reported that the accounts for the month ended November 30, 1891, as certified by the Society's accountants, showed receipts amounting to 2,425*l.* 10*s.* 3*d.*, and expenditure amounting to 1,919*l.* 13*s.* 6*d.* The balance at the bankers on November 30, allowing for cheques outstanding, was 3,448*l.* 7*s.* 11*d.* Accounts amounting in all to 2,58*l.* 15*s.* 9*d.* had been passed, and were recommended for payment. The balance-sheet of the Doncaster Meeting, as passed by the auditors on November 16, showed as a final result a credit balance of 103*l.* 17*s.* 6*d.* The Committee recommended that Lloyd's Banking Company, Limited, of Warwick, be appointed local bankers for the Warwick Meeting. A bequest of 100*l.* had been made to the Society under the will of the late Mr. J. P. Stocker. The Committee recommended that the names of four life governors, seven life members, and eighteen annual members deceased, sixteen members resigned, one whose address could not be found, and forty-four in arrears of subscription, be struck off the register. The Committee had held twelve meetings (including three special) during the year, and had made nine reports.

### Legacy to Society of 100*l.*

Sir NIGEL KINGSCOTE said the Council would observe that a bequest

of 100*l.* had been made to the Society under the will of the late Mr. J. P. Stocker, who had been a member of the Society for nearly forty years. He believed this was almost the first instance of a bequest having been made to the Society by a member, but he hoped the example might prove contagious.

#### House.

Sir NIGEL KINGSCOTE (Chairman) reported that, at the request of the authorities, a loan had been made to the Victorian Exhibition of the plaster model of the third Earl Spencer, and of three lithographs and placards relating to the first Meeting of the Society held at Oxford in 1839. The Committee had met seven times and made seven reports.

#### Journal.

Mr. WHITEHEAD reported that the final arrangements for the next number of the Journal had been considered and approved. Various suggestions for articles and notes in the Journal had been discussed. A request from Messrs. Spottiswoode and Co., for an increase of their charge to members for the binding of the Journal, from 2*s.* to 2*s.* 3*d.* per volume, on account of the increase of wages in the book-binding trade, had been acceded to. Applications from Miss Ormerod for permission to reprint from her report on the diamond-back moth, and from the Conservatoire National des Arts et Métiers, of Paris, for the use of blocks illustrating the report on the compound engines tried at Newcastle in 1887, had been granted on the usual conditions. The Committee had met nine times and made nine reports.

#### Chemical.

Mr. WARREN reported that the annual report for 1891 of the Consulting Chemist had been received, and would appear in the next number of the Journal (see page 835). The draft Quarterly Report of the Committee had been considered and adopted. A letter from the Netherlands Chamber of Commerce, referring to a resolution passed at the International Agricultural Congress at The Hague, on the subject of the adulteration of food, and suggesting

the formation of an International Convention, had been considered. The Committee had given a general approval of the proposal, and recommended that it should be brought to the notice of the Board of Agriculture. The Committee had met eight times and made eight reports.

On the motion of Mr. WARREN, the Quarterly Report of the Chemical Committee was adopted by the Council, and ordered to be published in the next number of the Society's Journal (see page 814).

#### Seeds and Plant Diseases.

Mr. WHITEHEAD (Chairman) presented the report of the Potato Subcommittee on the experiments with "Bouillie Bordelaise," which had been conducted during the past season (see page 828). The Committee recommended that a letter should be addressed to Mr. E. Riley, expressing the Society's appreciation of the satisfactory manner in which he had conducted the experiments. The annual reports for 1891 of the Consulting Botanist and Hon. Consulting Entomologist were submitted, and were recommended for publication in the next number of the Journal (see pages 845 and 849). The Committee had met seven times and made seven reports.

#### Proposed International Fruit Exhibition in 1892.

The SECRETARY read a letter from Sir James Whitehead, seeking the Society's support to a proposed International Fruit Exhibition in London next year, and asking the Council to nominate a gentleman upon the Provisional Committee.

Mr. WHITEHEAD thought it would be a graceful act on the part of the Society to support Sir James Whitehead in this matter, and he hoped the Council would encourage fruit-growing in the manner suggested. It seemed to him that the proposed exhibition would both directly and indirectly encourage the growth of fruit in this country, by showing farmers and others how satisfactorily fruit could be grown and packed by other nations. Especially with regard to apples was it most desirable to level up to the colour and quality of the apples pro-

duced in Australasian countries and other parts of the world. On those grounds he ventured to hope that the Council would agree with the request of Sir James Whitehead, and appoint member to serve on the Committee.

Mr. SUTTON seconded the motion, saying that he thought nothing could be more important at the present time than to do something to make the orchard of every farmhouse a more paying concern than it was at present. It would be a good result of the holding of such an exhibition if that portion of the land which was set apart for fruit were made to yield a substantial return for the labour expended upon it.

The resolution was then unanimously passed; and on the motion of Sir JACOB WILSON, seconded by Mr. CHANDOS-POLE-GELL, Mr. Charles Whitehead was appointed as the Society's representative to serve upon the Provisional Committee.

#### Veterinary.

Sir JOHN THOROLD (Chairman) reported that Professor Brown had written for the next number of the Journal an article on the subject of Abortion in Cattle (see p. 729). At the request of the Committee, Professor Brown had undertaken to include in his paper a note upon the effect of ergot in relation to abortion. Of the 600*l.* granted to the Committee for the year 1891, 552*l.* 14*s.* had been expended, and the Committee moved for a renewal of the grant, 500*l.* of which was intended to be allocated to the Royal Veterinary College for the study of comparative pathology and bacteriology. They had met nine times and made nine reports during the year.

Professor Brown had presented the following report:—

**PLEURO-PNEUMONIA.**—In the course of the twelve months during which the Pleuro-pneumonia Act has been in operation. September 1890 to September 1891, 295 outbreaks of the disease occurred; 1,188 cattle affected with pleuro-pneumonia were slaughtered, and 13,134 cattle which had been in contact with diseased beasts or otherwise exposed to infection were

also killed. To these may be added 243 cattle which were suspected to be suffering from disease, making a total of 14,565 cattle slaughtered by order of the Board.

In the course of the earlier part of the twelve months the disease existed in thirty-four counties in Great Britain—viz. twenty-five in England, and nine in Scotland, but during the last month of the twelve, viz., August, it was confined to seven counties in England and one in Scotland.

In the past three months, September, October, and November, there were only twenty-six outbreaks of pleuro-pneumonia in Great Britain, and these were confined to seven counties in England and one in Scotland. In the corresponding period of last year, when the Board of Agriculture began the work of stamping out the disease, there were 116 fresh outbreaks.

**ANTHRAX.**—During the month of November there were twenty-five outbreaks of this disease in Great Britain. They occurred in the counties of Dorset, Durham, Kent, Leicester, Surrey, Sussex (East), Warwick, Wilts, York, (W.R.), and Aberdeen. There were forty-nine animals attacked, one of which was killed, thirty-eight died, and four recovered.

**SWINE FEVER.**—This disease is now and has for some time been decreasing. In the month of November there were 284 outbreaks reported, an average of seventy-one per week, whereas in October the outbreaks averaged eighty-eight per week. The number of swine attacked in November was 1,874. There were during the month 860 diseased pigs killed, 934 died, 277 recovered, and 371 remained alive when the return was made up.

#### Stock Prizes.

Mr. SANDAY (Chairman) reported that a memorial received from the Highland Cattle Society and others, either breeders of or interested in Highland cattle, asking for classes for that breed at the Warwick Meeting had been further considered, in con-

nection with an offer of prizes by the Warwick Local Committee for four classes of Highland cattle. A letter had also been received from the Polled Cattle Society on the subject of prizes for the Aberdeen-Angus breed at Warwick. After considerable discussion, the Committee had unanimously resolved that no prizes could be offered in connection with the Warwick Meeting for Scotch breeds of cattle. The Committee could not, therefore, see their way to recommend the acceptance of the prizes by the Local Committee. An offer of a champion prize by the Red Polled Society for the best Red Polled bull, cow, or heifer exhibited had been accepted with thanks. The Committee having now finally revised the prize sheet and regulations for the Warwick Meeting, recommended them to the Council for approval and issue forthwith. They also recommended that the Chairman be empowered to accept any champion prizes from breed societies which might be offered before the prize sheet was printed, and which complied with the regulations of the prize sheet. The Committee had met seven times, and made seven reports.

Mr. SANDAY added that since the meeting of the Committee an offer had been received from the Shorthorn Society of two champion prizes of 25*l.* each for the best male and the best female Shorthorn exhibited at Warwick; and this offer was accepted with thanks.

Mr. ASHWORTH announced that the British Berkshire Society had voted a champion prize of 10*l.* for the best Berkshire pig exhibited in the boar and sow classes. This offer was also accepted.

An offer made on behalf of some breeders and feeders of Kerry or Dexter Kerry cattle of the prize money for an additional class of Kerry and Dexter heifers under three years of age, was declined.

In moving the adoption of the draft prize sheet for Warwick, Mr. SANDAY said that since the meeting of the Committee a suggestion had been made which seemed a very valuable one, that no pigs which had been exhibited as fat stock at any show should be eligible to compete for the

Society's prizes; and he therefore moved the addition of a regulation to this effect.

Mr. ASHWORTH thought the proposed rule was a most important one, and he strongly supported it.

Mr. GARRETT TAYLOR pointed out that notice had not been given to exhibitors, and moved as an amendment that the new regulation be postponed until the show of 1893.

Mr. C. W. WILSON seconded the amendment, which on a division was lost by nine votes to fourteen.

The prize sheet, with the addition of the proposed new regulation, was then formally approved and ordered to be issued.

#### Implement.

Mr. CRUTCHLEY reported that a selection of land suitable for the purposes of the plough trials next spring had been made, and the Committee recommended that the Local Committee be requested to complete the arrangements for securing the land selected. Other arrangements for the trials were in progress. The Committee had met seven times and made seven reports.

#### General Warwick.

Sir JOHN THOROLD reported that the Local Committee had nominated as agents for the sale of dairy produce Messrs. Thacker and Christmas of Warwick (for cheese), and Mr. T. Palmer, of Hampton Lodge, Warwick, (for butter and table poultry); and as agents for lodgings Mr. T. Sallaway, Jury Street, Warwick (for Warwick), and Mr. C. C. Garner, Baddesley Lodge, Leamington (for Leamington). The Local Committee had agreed to provide a gold medal for each of the three thoroughbred stallions for which the Society were giving premiums during the ensuing season.

#### Showyard Works.

Sir JACOB WILSON presented the report of this Committee on various matters of detail connected with the showyard. The Committee had met nine times and made nine reports.

#### Committee of Selection.

Mr. CHANDOS-POLE-GELL reported the recommendations of this Commit-

tee:—(1) That the Committee of Inspection for the Country Meeting of 1893 be constituted of the President, Sir Nigel Kingscote, Sir Jacob Wilson, Mr. Bowen-Jones, Mr. Crutchley, Mr. Hornsby, and the Secretary; and (2) that Mr. Christopher Wilson be elected a Steward of Stock, Mr. Rowlandson a Steward of Implements, and Mr. Darby the Steward of Dairying. They also presented their recommendation for the election of two distinguished foreign agriculturists as Honorary Members of the Society, viz.:—Professor Hermann Hellriegel, Director of the Versuchs Station, Bernburg, Anhalt, Germany, and Dr. C. J. Sikesz van der Cloese, President of the Royal Agricultural Commission of Holland, The Hague.

**Election of Honorary Members.**

The first and second recommendations of the Committee having been adopted, Mr. CHANDOS-POLE-GELL formally moved and Mr. CHARLES WHITEHEAD seconded, the election of Professor Hellriegel, and the Hon. CECIL T. PARKER moved and Mr. C. S. MAINWARING seconded, the election of Dr. Sikesz. These resolutions were carried unanimously, and the Diplomas of Honorary Membership were then sealed with the Society's seal and signed by the President and Secretary.

**Education.**

Mr. TREMAYNE reported that of the forty-seven candidates from the ten schools entered for the Society's Junior Examination on the 10th and 11th ultimo, forty-five actually presented themselves, and of these, eighteen obtained the number of marks necessary to qualify them for the Society's scholarships and certificates. The Committee presented a report on the results of the examinations for publication in the Journal (see page 823). A question raised by an intending competitor as to whether a candidate who had gained the first-class certificate in the Senior Examination might again compete had been discussed, and it had been decided to reply in the negative, and to insert a regulation to this effect in the next issue of the syllabus. The text-book which the Committee had undertaken to

prepare, in compliance with the many demands that had been addressed to the Society for an elementary work on agriculture adapted for use in rural and other schools and classes was now completed, and would be published on January 1 next, under the authority of the Society, by Mr. John Murray, at the price of half a crown. Of the 500*l.* granted to the Committee for the year 1891, they had expended 466*l.* 6*s.* 2*d.*, exclusive of the cost of the twenty-four insect diagrams recently published and the expenses of the text-book. They moved for a renewal of the grant for the year 1892. The Committee had met seven times and made seven reports.

**Dairy.**

The Hon. CECIL T. PARKER reported that the Committee had considered a letter from Viscount Hampden, President of the English Jersey Cattle Society, urging additional reasons why the Society should give prizes for dairy cattle, subject to a butter test by a churn, as to which the Council had decided at their last meeting that such prizes could not be received. The Committee recommended that the Secretary be instructed to inform the English Jersey Cattle Society that the Council had again considered the matter, and were still of opinion that the practical difficulties which they foresaw in carrying out a butter test by the churn prevented any satisfactory conclusion being arrived at. The Committee had expended all the 100*l.* granted to them for 1891, and moved for a renewal of the grant for 1892. The Committee had met six times and made six reports.

**Standing Committees for 1892.**

The following Standing Committees were appointed for 1892 viz:—

Finance.	Stock Prizes.
House.	Implement.
Journal.	General Warwick.
Chemical.	Showyard Works.
Seeds and Plant Diseases.	Selection.
Veterinary.	Education.
	Dairy.

The present members of the Finance, House, Journal, Chemical, Education, and Dairy Committees, and (with one

or two exceptions) of the Seeds and Plant Diseases, Veterinary, Stock Prizes, Implement, and Showyard Works Committees were re-elected. Mr. Ashworth was added to the Seeds and Plants Committee, Mr. Caird to the Implement Committee, Mr. Marshall Dagdale to the Education and Dairy Committees, Col. Curtis-Hayward to the Veterinary and Dairy Committees, Mr. Martin Sutton to the Woburn Sub-Committee, and Mr. Stanyforth to the Showyard Works Committee. To replace Messrs. Caird, Chandos-Pole-Gell, and Warren, who retired from the Committee of Selection by rotation, Messrs. Ashworth, Tremayne, and Garrett Taylor were elected.

#### Committee for Selection of Judges.

On the motion of Sir JACOB WILSON, seconded by Mr. S. P. FOSTER, a Committee was appointed to recommend Judges of Stock, Poultry, and Produce at the Warwick Meeting, such Committee to consist of the members of the Stock Prizes Committee and the Stewards of the several departments, and to sit for the first time in February next.

Mr. FOSTER raised the question as to the appointment of two judges instead of three, and referred to other matters in connection with the judging. He would like the Committee to receive an instruction from the Council to appoint two judges only.

Sir JACOB WILSON objected to any such instruction being given beforehand to the Committee, and said it was quite competent for Mr. Foster to raise the question in Committee, when it could be discussed.

The DUKE of RICHMOND AND GORDON agreed with Sir Jacob Wilson in thinking that the matter should be left to the Committee, without instructions from the Council.

Mr. GILBEY concurred in this view, though, having acted both as an exhibitor and judge at past shows, he was strongly in favour of two judges instead of three. He suggested as a way out of the difficulty that three judges should be nominated, but that only two should judge, the third not going into the ring unless called upon.

Mr. MARTIN thought the Society should publish the names of the judges in the prize sheet as other societies did, and moved a resolution to that effect. This was supported by Mr. C. W. WILSON, but eventually the motion was by leave withdrawn.

After some further discussion on Mr. Foster's suggestion, in which the Duke of RICHMOND and GORDON, Sir NIGEL KINGSCOTE, Sir JACOB WILSON and others took part, a motion to pass to the next business was carried.

#### Country Meeting of 1893.

The invitations received from the Corporations of Chester and Manchester, inviting the Society to hold its Country Meeting of 1893 in their respective localities, were further considered, and the SECRETARY read a number of resolutions and memorials from various town councils and other bodies in support of each application. These were referred to the Committee of Inspection already appointed, with instructions to bring up at the meeting of the Council in February next a report on their inspection of the sites and other accommodation offered by each locality.

#### Miscellaneous.

Letters were read (1) from Mr. Richard Stratton, resigning his seat on the Thoroughbred Stallion Committee; (2) from M. Méline, President of the Commission Internationale d'Agriculture, asking for contributions towards the expenses of the Commission; (3) from the Science and Art Department, transmitting particulars of an agricultural exhibition to be held at Philippopolis, from August 2nd to October 31st, 1892; (4) from the Mansion House Association on railway rates.

#### Date of next Meeting.

The report of the Council to the general meeting on the following day having been prepared, and other business transacted, the Council adjourned over the Christmas recess until Wednesday, February 3rd, 1892.



## Proceedings at Half-yearly Meeting of Governors and Members,

HELD IN THE HALL OF THE ROYAL MEDICAL AND CHIRURGICAL SOCIETY,  
20 HANOVER SQUARE.

THURSDAY, DECEMBER 10, 1891.

THE EARL OF FEVERSHAM (PRESIDENT) IN THE CHAIR.

**Present:—**

*Members of Council.*—Col. Sir Nigel Kingscote, K.C.B. (Trustee), Sir John H. Thorold, Bart. (Vice-President), Sir Jacob Wilson, Messrs. G. Mander Allender, J. Bowen-Jones, Lieut.-Col. J. F. Curtis-Hayward, Messrs. J. Marshall Dugdale, S. P. Foster, Wm. Frankish, Charles Howard, C. S. Mainwaring, T. H. Miller, Albert Pell, G. H. Sanday, Henry Smith, E. Wilfrid Stanyforth, Martin J. Sutton, and C. W. Wilson.

*Members.*—Sir G. Macpherson-Grant, Bart. (Governor), Sir J. Heron-Maxwell, Bart., Messrs. Ralph Arnold, R. C. Assheton, George Barham, John Barron, H. W. B. Berwick, George Blake, Professor Brown, C.B., Thomas Charnock, Horace F. Cox, Major Craigie, Messrs. J. Kersley Fowler, George Gibbons, H. Foord Harris, J. Harris, C. H. Hooper, C. F. Hope, Frederick King, R. Jasper More, M.P., Ralph Palmer, Clare Sewell Read, E. Riley, J. E. Scotson, W. Scotson, Thomas Stirton, G. F. Strawson, George Sutton, W. A. G. Taylor, Howard Thomas, John Thornton, Jonas M. Webb, &c.

*Officers.*—Mr. Ernest Clarke, Secretary and Editor; Dr. J. Augustus Voelcker, Consulting Chemist.

The half-yearly Report of the Council (see page 805) having been taken as read, the SECRETARY gave a brief synopsis of its contents.

MR. CLARE SEWELL READ, in moving the adoption of the report, said he did so with much pleasure, because it appeared to him that their great

national Society had not suffered from the reaction of its Jubilee year, but had renewed its earnestness and increased its strength. With regard to pleuro-pneumonia, he was very glad to say that, although one or two members of the Council had cast some doubt upon the value of the efforts made by the Board of Agriculture for the suppression of that most virulent disease, the Board was, he believed, on the fair road to success. In his own county the course adopted had been a complete and entire success. No county had formerly suffered more than Norfolk from this disease, and they had declared for years and years that they received a considerable proportion of that disease from Ireland. Since the Pleuro-pneumonia Act had been faithfully and fairly put in force in Ireland, they had not had a single case of pleuro-pneumonia in Norfolk: not one case since last September twelve months. In the previous year the Norfolk County Council had paid no less than 5,000*l.* for the animals slaughtered. They, in Norfolk at least, had reason to be satisfied with the experiment. He quite acquiesced with the suggestion of the Council to the Board of Agriculture that more stringent measures should be adopted in regard to swine fever, because he believed that the varying and conflicting orders issued by the various local authorities, although extremely costly to the ratepayers of every county where that disease existed, resulted in the squandering of money. He hoped either that the Board of Agriculture would make those autho-

rities more reasonable, or else be pleased to take the whole management into their own hands as they had done in the case of pleuro-pneumonia. He was quite sure that this would be for the good of the country, and would give great satisfaction throughout the kingdom. After expressing his great gratification that the small difference which existed between the Entomologist and the Society had been cleared up, he formally moved the adoption of the report.

Sir JOHN HERON MAXWELL seconded, expressing his pleasure as a north countryman that amongst the eighteen candidates who had passed the Junior Examination no less than nine were from the north, whilst amongst the ten who would receive scholarships no less than six were from the Aspatia Agricultural College; and one from the other side of the border, at Maybole. When so much was being done for technical education, this was very creditable, and was another evidence that they, the north countrymen, were not behindhand.

Mr. RALPH PALMER, with reference to the large amount of credit which the last speaker claimed for north countrymen, and especially for the Aspatia College, pointed out that two years ago, when there were fifty-one boys in that college, more than half came from the south of the Thames.

Mr. FOSTER wished to say, as he said last year at that meeting, that it was entirely owing to the grant given to the college by the Board of Agriculture and their predecessors that Aspatia had been able to achieve the results it had. Whilst the last speaker was perfectly right that many of their boys came from the south, it was gratifying to think that although they were southern born they were northern educated.

The report was then unanimously adopted.

#### **Vote of Thanks to Auditors.**

Mr. W. SCOTSON then moved the usual vote of thanks to the Auditors (Messrs. Francis Sherborn, A. H. Johnson, and C. Gay Roberts), and their re-election for the ensuing year.

Mr. GEORGE GIBBONS, in second-

ing, took the opportunity of expressing his pleasure at the proposal of the Council to offer increased prizes for Dairy produce in the year 1893, and pointed out the immense importance of stimulating the dairy industry and of improving the technical education of those interested in it, seeing that an annual sum of twenty million pounds was paid by this country for foreign produce. He also referred to the subject of pleuro-pneumonia, insisting upon the wisdom and importance of prohibiting the importation of animals from any country that was not known to be free from the disease.

The vote of thanks was passed unanimously.

#### **Suggestions for Consideration of Council.**

In response to the usual inquiry from the Chair as to whether any of the members present had any questions to ask or suggestions to offer for the consideration of the Council,

Mr. GEORGE BARHAM expressed regret that no reference had been made in the report to railway rates. He regretted this the more because the Mansion House Committee had issued their Report, in which they thanked the representatives of the Society for the services they had rendered. He did not know anything that affected the value of land or of agriculture more than their railway rates. Although they had gained a great deal by the action taken before the Joint Committee, yet there were many things to be done, and he thought it behoved the Society to keep a watchful look-out for the future, and to study the matter in every possible way in the interests of agriculturists. One other point was the railway rates in connection with the implement exhibits at the Shows. Their Council had very great power; and when they were deciding the locality of the Show, that was the time for them to approach the railway companies and ask for advantages for those who largely made the success of the Show. Owing to the joint action of that Society and other agricultural bodies not very long since, exhibitors were given half-rates for the return of implements and live-stock from the Shows.

He was told that all claims for accidents, &c. only applied when full rates were paid. He thought some improvement should be made in that respect. Then the implement exhibitors were under an immense disadvantage because they were compelled to pay full rates for their servants both going to and returning from the Show. In the case of exhibitors of stock they were able to have one or two men carried free with their animals. The implement exhibitors were unable to take advantage of excursion tickets, inasmuch as their employés had to attend the Show, in many cases, days and weeks before the Show opened, and they did not return until some time afterwards.

Mr. Barham also criticised the trials of cream separators which took place at Doncaster this year, saying that the Society's trials should be so exhaustive and complete that agriculturists who had to buy a machine should know which was the best one.

Mr. C. F. HOPE made suggestions in regard to increased facilities for passenger traffic to the Shows through the issue by railway companies of contract tickets, and, as an agricultural lecturer, suggested the granting of facilities for photographing prize animals in the showyard, to be used as illustrations of approved points.

Mr. J. K. FOWLER suggested that the system of steam cultivation should again be brought to the front. Some years ago, he was very much interested in the subject as a tenant farmer, and had his own set of tackle. Since that time there had been improvements made, and he thought the time had now come when the Society should give some opportunity for the inventors of those most valuable implements again to come into competition. The subject was now being talked about by the Farmers' Club; and he thought it quite right that the Society should consider it themselves. He also referred to an interesting article by their Secretary in the Journal for June, on "Sugar-Beet Cultivation in Austria," and called attention to the fact that this country, especially Ireland, could produce immense quantities of sugar from Silesian beet. He had visited Ireland, and found that the climatic influences of that

country and a great part of England could be shown to be available for the production of sugar, as well as in Holland, Belgium, and a great part of the Continent. It was not perhaps known to the general public that 75 per cent. of the sugar consumed in England was beet-root sugar, and only 25 per cent. was cane sugar. We paid Germany, France, Austria, Belgium, and Holland 15,000,000*l.* sterling per annum for a product which he was quite confident could be grown in this country. It was time, therefore, that that Society should see whether this great industry could not be developed. It was possible that a committee might be formed to get all the information they could on this important subject. It would be said that the bounty system was difficult to overcome: within a few months that would be materially altered; but one of the great reasons why the governments of the Continent offered these bounties was not so much as a fiscal operation as for the improvement of the agriculture of the country. The immense improvement in the fertility of the soil around which beetroot culture was carried on was quite sufficient inducement for the governments of the Continent to offer a bounty.

#### Votes of Thanks to Chairman.

Mr. R. JASPER MORE, M.P., in proposing a vote of thanks to the President for presiding over the meeting, said that in these days they in London heard a great deal of those who were at both ends of the agricultural ladder, the great landlords in the House of Lords, and the agricultural labourers. They did not hear so much as they could wish of the farmers. The best chance these had of being able to make their opinions felt in London, and of drawing attention to their needs, was when they were met by one of the great landowners in the chair. He ventured to thank his Lordship for presiding over them on that occasion, and he congratulated the Society on the great advantage of having the chairmanship of the noble Lord during the past year. He knew his Lordship chiefly as being a breeder of Short-horns, but he begged that he would

not the less deign to accept that vote from him (Mr. More) because he came from a county famous for Herefords and sheep.

Mr. J. K. FOWLER seconded the motion, which was carried unanimously.

The PRESIDENT thanked the meeting very much for the kind way in which they had received the vote, which had only been too flatteringly and handsomely proposed and seconded by his friends Mr. More and Mr. Fowler. It afforded him great gratification to assist in any way he could the great cause of agriculture which they all had at heart, and he felt proud at having been appointed to the high position of President of the Royal Agricultural Society. He only feared that he might not be able to do justice to the important duties which devolved upon the President of that great Society. With regard to what had been said by Mr. Read on the efforts made by the Board of Agriculture to stamp out pleuro-pneumonia, which had, he was happy to say, been so successful, and with regard to the further efforts which should be made to stamp out that terrible disease of swine fever, he need not say that the Council were in cordial agreement with the speakers, and would give every assistance in their power to the Board of Agriculture. He rejoiced to think that every part of this island had been successful in obtaining the scholarships and certificates at the Junior Examination. He was glad that there should be that friendly rivalry between the north and the south to which reference had been made, and he hoped the result might be that it would add to the science as well as the practice of agriculture in this country. With regard to the question of railway rates and facilities for the carriage of stock and implements, he must remind Mr. Barham that a Railway Act had passed Parliament very lately, and that of course the Council could not regulate the rates, though they might express their wishes and opinions to the Railway Companies. With regard to photographic apparatus in the showyard, he thought it would at once be seen that if any one gentleman were allowed to bring in his camera others would expect the same privi-

lege, and he was afraid it would rather interfere with the facilities of the public in getting about the Show. As to what Mr. Fowler had said in reference to the cultivation of the beet-root for sugar and the operation of the bounty system, he always thought that Englishmen had generally found out what the soil of their country was best suited to produce. He could not help feeling that if beet-root for the manufacture of sugar could have been made profitable, it would have been grown in this country. With regard to the bounty system, Englishmen did not look to the Government for bounties, but liked to rely upon their own energies; and that was the source of the strength and success of their country in the various industries which they had carried on. He would not now refer further to these suggestions, which would no doubt receive the attention of the Council, but before he sat down he wished to propose a vote of congratulation upon an event which had been received with the greatest satisfaction and pleasure by all classes of the country. He referred to the approaching marriage of the Duke of Clarence. (Cheers.) The Duke was a member of that Society; and he (the President) was sure they would not wish to separate that day without offering their hearty congratulations to His Royal Highness. It had been thought better that a resolution of this kind should be proposed at a general meeting of the members of the Society rather than at the Council meeting held on the previous day, since he felt sure that the whole of the members of their very large and important Society would wish to have the opportunity of adding their voices to the universal chorus of congratulation with which the announcement of this auspicious event had been greeted by all classes. (Cheers.)

Mr. CLARE SEWELL READ said he hoped he might be allowed the privilege of seconding the resolution of congratulation, especially as the Duke was President of the Norfolk Agricultural Society for this year.

The resolution was passed by acclamation, and the meeting then terminated.

## PRIZE LIST

FOR

WARWICK MEETING, JUNE 18 to 24, 1892.

Total value of Prizes offered (exclusive of Champion Prizes and Medals offered by Breed Societies), £5,018, of which amount £845 are contributed by the Warwick Local Committee.

## HORSES (£1,265).

Class	HUNTERS.	Prizes			Class	HARNESS HORSES AND PONIES.	Prizes		
		1st £	2nd £	3rd £			1st £	2nd £	3rd £
1	MARE AND FOAL . . . . .	20	10	5	21	MARE OR GELDING, of any age, above 14 hands <sup>1</sup> . . . . .	15	10	-
2	MARE OR GELDING, up to 15 st., foaled 1886 or '87 <sup>1</sup> . . . . .	25	15	10	22	MARE OR GELDING, of any age, not over 14 hands <sup>1</sup> . . . . .	15	10	-
3	MARE OR GELDING, up to 12 st., foaled 1886 or '87 <sup>1</sup> . . . . .	25	10	5	<b>SHIRE.</b>				
4	MARE, foaled in 1888 <sup>1</sup> . . . . .	25	10	5	23	STALLION, foaled in 1880 . . . . .	20	10	5
5	GELDING, foaled in 1888 <sup>1</sup> . . . . .	25	10	5	24	STALLION, foaled in 1890 . . . . .	20	10	5
6	MARE OR GELDING, foaled in 1889 <sup>1</sup> . . . . .	15	10	5	25	STALLION, foaled in 1891 . . . . .	20	10	5
7	FILLY, foaled in 1889 . . . . .	15	10	5	26	MARE AND FOAL . . . . .	20	10	5
8	FILLY, foaled in 1890 . . . . .	15	10	5	27	FILLY, foaled in 1889 . . . . .	15	10	5
<b>COACH HORSES.</b>					28	FILLY, foaled in 1890 . . . . .	15	10	5
9	STALLION, foaled in 1888, 1889, or 1890 . . . . .	15	10	5	29	FILLY, foaled in 1891 . . . . .	15	10	5
10	MARE AND FOAL <sup>1</sup> . . . . .	15	10	5	<i>Two Gold Medals are offered by the Shire Horse Society for the best Shire Stallion and Mare or Filly.</i>				
<b>HACKNEYS.</b>					<b>CLYDESDALE.</b>				
11	STALLION, foaled in 1888, 1889, or 1890, above 15 hands . . . . .	15	10	5	30	STALLION, foaled in 1889 . . . . .	20	10	5
12	STALLION, foaled in 1888, 1889, or 1890, above 14 hands and not over 15 hands . . . . .	15	10	5	31	STALLION, foaled in 1890 . . . . .	20	10	5
13	BROOD MARE AND FOAL, above 15 hands . . . . .	15	10	5	32	MARE AND FOAL . . . . .	20	10	5
14	BROOD MARE AND FOAL, above 14 hands and not over 15 hands . . . . .	15	10	5	33	FILLY, foaled in 1889 . . . . .	15	10	5
15	MARE OR GELDING, above 14 hands, up to 15 stones, foaled in 1886, '87, or '88 <sup>1</sup> . . . . .	15	10	5	34	FILLY, foaled in 1890 . . . . .	15	10	5
16	MARE OR GELDING, above 14 hands, up to 12 stones, foaled in 1886, '87, or '88 <sup>1</sup> . . . . .	15	10	5	<i>Two Champion Prizes of £25 each, for the best Clydesdale Stallion and Mare or Filly, are offered by the Clydesdale Horse Society.</i>				
<b>PONIES.</b>					<b>SUFFOLK.</b>				
17	STALLION, not over 14 hds. . . . .	15	10	5	35	STALLION, foaled in 1889 . . . . .	20	10	5
18	BROOD MARE AND FOAL, not exceeding 14 hands. . . . .	15	10	5	36	STALLION, foaled in 1890 . . . . .	20	10	5
19	MARE OR GELDING, above 13 hands and not over 14 hands <sup>1</sup> . . . . .	10	5	-	37	MARE AND FOAL . . . . .	20	10	5
20	MARE OR GELDING, not exceeding 13 hands <sup>1</sup> . . . . .	10	5	-	38	FILLY, foaled in 1889 . . . . .	15	10	5
					39	FILLY, foaled in 1890 . . . . .	15	10	5
					<b>AGRICULTURAL HORSES.</b>				
					40	GELDING foaled in 1889, got by a Stallion registered in the Shire Horse Stud Book <sup>1</sup> . . . . .	10	5	-
					41	GELDING foaled in 1890, got by a Stallion registered in the Shire Horse Stud Book <sup>1</sup> . . . . .	10	5	-

<sup>1</sup> Offered by the Warwick Local Committee.

**CATTLE (£1,361).**

Class	SHORTHORN.	Prizes		
		1st	2nd	3rd
		£	£	£
42	BULL, calved in 1886, 1887, 1888, or 1889	. 15	10	5
43	BULL, calved in 1890	. 15	10	5
44	BULL, calved in 1891	. 15	10	5
45	Cow, in-milk or in-calf, calved previously to 1889	15	10	5
46	HEIFER, in-milk or in-calf, calved in 1889	. 15	10	5
47	HEIFER, calved in 1890	. 15	10	5
48	HEIFER, calved in 1891	. 10	5	-

Two Champion Prizes of £25 each are offered by the Shorthorn Society of Great Britain and Ireland for the best Male and the best Female Shorthorn.

**HEREFORD.**

49	BULL, calved in 1886, 1887, 1888, or 1889	. 15	10	5
50	BULL, calved in 1890	. 15	10	5
51	BULL, calved in 1891	. 15	10	5
52	Cow in-milk or in-calf, calved previously to 1889.	15	10	5
53	HEIFER, in-milk or in-calf, calved in 1889	. 15	10	5
54	HEIFER, calved in 1890	. 15	10	5
55	HEIFER, calved in 1891	. 10	5	-

Two Champion Prizes of £15 each, for the best Male and the best Female Hereford are offered by the Warwick Local Committee.

**DEVON.**

56	BULL, calved 1887, '8, or '9	15	10	5
57	BULL, calved in 1890	. 15	1	5
58	BULL, calved in 1891	. 10	-	-
59	Cow or HEIFER, in-milk or in-calf, calved previously to or in 1889	. 15	10	5
60	HEIFER, calved in 1890	. 15	10	5
61	HEIFER, calved in 1891	. 10	5	-

**SUSSEX.**

62	BULL, calved 1887, '8, or '9	15	10	5
63	BULL, calved in 1890	. 15	10	5
64	BULL, calved in 1891	. 10	5	-
65	Cow or HEIFER, in-milk or in-calf, calved previously to or in 1889	. 15	10	5
66	HEIFER, calved in 1890	. 15	10	5
67	HEIFER, calved in 1891	. 10	5	-

**LONGHORN.**

68	BULL, calved in 1888, 1889, or 1890 <sup>1</sup>	. 10	-	-
69	Cow or HEIFER, of any age, in-milk or in-calf <sup>1</sup>	. 10	-	-

**WELSH.**

70	BULL, calved 1887, '8, or '9	10	5	-
71	BULL, calved 1890 or 1891	10	5	-
72	Cow or HEIFER, in-milk or in-calf, calved previously to or in 1889	. 10	5	-
73	HEIFER, calved in 1890	. 10	5	-
74	HEIFER, calved in 1891	. 10	5	-

Class	RED-POLLED.	Prizes		
		1st	2nd	3rd
		£	£	£
75	BULL, calved 1887, '8, or '9	15	10	5
76	BULL, calved in 1890	. 15	10	5
77	BULL, calved in 1891	. 10	5	-
78	Cow or HEIFER, in-milk or in-calf, calved previously to or in 1889	. 15	10	5
79	HEIFER, calved in 1890	. 15	10	5
80	HEIFER, calved in 1891	. 10	5	-

A Champion Prize of Ten Guineas is offered by the Red-Polled Society for the best Red-Polled animal exhibited.

**JERSEY.**

81	BULL, calved in 1888, 1889, or 1890	. 15	10	5
82	BULL, calved in 1891	. 10	5	-
83	Cow, in-milk, calved previously to or in 1888	. 15	10	5
84	Cow, in-milk, calved in 1889	15	10	5
85	HEIFER, in-milk or in-calf, calved in 1890	. 15	10	5
86	HEIFER, calved in 1891	. 10	5	-

**GUERNSEY.**

87	BULL, calved in 1888, 1889, or 1890	. 15	10	5
88	BULL, calved in 1891	. 10	5	-
89	Cow or HEIFER, in-milk, calved previously to or in 1889	. 15	10	5
90	HEIFER, calved in 1890	. 15	10	5
91	HEIFER, calved in 1891	. 10	5	-

**KERRY.**

92	BULL, calved in 1889, 1890 or 1891	. 10	5	-
93	Cow or HEIFER, of any age, in-milk or in-calf	. 10	5	-

**DEXTER KERRY.**

94	BULL, calved in 1889, 1890, or 1891	. 10	5	-
95	Cow or HEIFER, of any age, in-milk or in-calf	. 10	5	-

**DAIRY CATTLE.**

Cows, in-milk (of any breed or cross) giving the greatest quantity of milk containing not less than 12 per cent. solids and 3 per cent. butter-fat.

96	Cow which has calved not less than three months before the date of the Show	. 10	7	5
97	A. Cow, of 1,100 lb. or over, live weight, irrespective of date of calving	. 10	7	5
97	B. Cow, under 1,100 lb. live weight, irrespective of date of calving	. 10	7	5

<sup>1</sup> Offered by the Warwick Local Committee.

### SHEEP (£900).

Classes				
98—101	Leicester	.	.	.
102—105	Cotswold	.	.	.
106—109	Lincoln	.	.	.
110—113	Oxford Down	.	.	.
114—119	Shropshire (6 classes)	.	.	.
120—123	Southdown	.	.	.
124—127	Hampshire Down	.	.	.
128—131	Suffolk	.	.	.
132—134	Border Leicester (3 cl.)	.	.	.
135—136	Clun Forest (2 classes)	.	.	.
137—138	Welsh Mountain do.	.	.	.

For Prizes see below

In each of the above breeds (except Border Leicester, Clun Forest, and Welsh Mountain) the following prizes will be offered:

	1st	2nd	3rd
	£	£	£
TWO-SHEAR RAM	10	5	-
SHEARLING RAM	15	10	5
PEN OF THREE RAM LAMBS, dropped in 1892	10	5	-
PEN OF THREE SHEARLING EWES, of the same flock	15	10	5

A Champion Prize of £10 is given by the Warwick Local Committee for the best Oxford Down Ram, and of £15 for the best Shropshire Ram.

For the Shropshire breed, two additional Classes for Pens of Five Ewes, which have suckled lambs up to June 15, (£15, and £10, Class 118), and for Pens of Five Ewe Lambs (£15, and £10, Class 119) are offered by the Warwick Committee.

### GOATS (£35).

Class	1st	2nd	3rd
	£	£	£
139 HE GOAT, over 1 year <sup>1</sup>	4	2	1
140 SHE GOAT over 2 years <sup>1</sup>	4	2	1
141 SHE GOAT over 1 year and under 2 years <sup>1</sup>	4	2	1
142 MALE KID <sup>1</sup>	4	2	1
143 FEMALE KID <sup>1</sup>	4	2	1

Two Silver Medals are offered by the British Goat Society for the best Male and the best Female Goat or Kid exhibited.

### PIGS (£432).

Classes				
144—147	Large White	.	.	.
148—151	Middle White	.	.	.
152—155	Small White	.	.	.
156—159	Berkshire	.	.	.
160—163	Any Other Black Breed	.	.	.
164—167	Tamworth	.	.	.

For Prizes see below

In each of the above breeds the following prizes will be given:—

	1st	2nd	3rd
	£	£	£
BOAR, farrowed in 1891	10	5	3
PEN OF THREE BOAR PIGS, farrowed in 1892	10	5	3
BREEDING SOW, farrowed pre- viously to or in 1891	10	5	3
PEN OF THREE SOW PIGS, far- rowed in 1892	10	5	3

A Champion Prize of £10 is given by the British Berkshire Society for the best Berkshire Pig in Classes 156 and 158.

### POULTRY (£272 10s.).

#### FOWLS.

Prizes are offered for the best Cock, Hen, Cockerel, and Pullet respectively, of each of the following Breeds:—

Classes		s.	s.	s.
168—171	Dorking, Coloured	30	15	10
172—175	Dorking, Silver Grey	30	15	10
176—179	Dorking, White or any other variety	30	15	10
180—183	Game, Old English	30	15	10
184—187	Game, Indian	30	15	10
188—191	Houdan	30	15	10
192—195	Other French	30	15	10
196—199	Brahma	30	15	10
200—203	Cochin	30	15	10
204—207	Langshan	30	15	10
208—211	Wyandotte	30	15	10
212—215	Plymouth Rock	30	15	10
216—219	Scotch Grey	30	15	10
220—223	Minorca	30	15	10
224—227	Andalusian	30	15	10
228—231	Leghorn	30	15	10
232—235	Hamburgh	30	15	10
236—239	Any other variety (Bantams excepted)	30	15	10

#### Table Fowls.

240	Pair of Cockerels of 1892, of any pure breed	30	15	10
241	Pair of Pullets, ditto	30	15	10
242	Pair of Cockerels of 1892, first cross from any pure breeds	30	15	10
243	Pair of Pullets, ditto	30	15	10

#### DUCKS.

Prizes are offered for the best Drake, Duck, Young Drake, and Duckling respectively of each of the following Breeds:—

244—247	Aylesbury	30	15	10
248—251	Rouen	30	15	10
252—255	Pekin	30	15	10
256—259	Any other Useful Breed	30	15	10

#### Table Ducks.

260	Pair of Ducklings of 1892, of any pure breed	30	15	10
261	Pair of Ducklings of 1892, of a first cross from any pure breeds	30	15	10

#### GEESE.

		£	£	s.
262	Gander	2	1	10
263	Goose	2	1	10

#### TURKEYS.

264	Cock	2	1	10
625	Hen	2	1	10

**PRODUCE (£236 15s.).**

Class	CHEESE. (of 1892 make)	Prizes			
		1st	2nd	3rd	4th
266	THREE CHEDDAR . . .	10	5	3	3
267	THREE CHESHIRE . . .	10	5	3	3
268	SIX STILTON . . .	10	5	3	3
269	THREE of any other British make . . .	10	5	3	3
270	THREE CREAM . . .	3	2	1	1

**BUTTER.**

271	2 lbs. FRESH BUT- TER, slightly salted	{ Four of 5l. each { Four of 3l. each { Four of 1l. each
272	6 lbs. FRESH BUTTER, <sup>1</sup> 1st 6l., 2nd 5l., 3rd 3l., 4th 1l.	
273	ONE KEG OR OTHER PACKAGE OF SALT BUTTER, 1st 5l., 2nd 3l., 3rd 2l., 4th 1l.	

**CIDER AND PERRY.**

Class	Description	1st	2nd	3rd
		£	£	£
274	Cask of CIDER, made 1891	5	3	2
275	One Doz. CIDER, made 1891	5	3	2
276	One Doz. CIDER, made before 1891 . . . . .	5	3	2
277	One Doz. PERRY . . . . .	5	3	2

**JAMS AND PRESERVED FRUITS.**

278	WHOLE-FRUIT JAMS . . .	3	2	1
279	BOTTLED FRUITS . . .	3	2	1
280	PRESERVED FRUITS for Dessert . . . . .	3	2	1
281	DRIED or EVAPORATED FRUITS for Cooking . . .	3	2	1

<sup>1</sup> Offered by the Warwick Local Committee.

**IMPLEMENTS (£120).**

(Entries closed).

1	SINGLE FURROW PLOUGH for light land . . . . .	£	10	5
2	SINGLE FURROW PLOUGH for strong land . . . . .	£	10	5
3	SINGLE FURROW PLOUGH best adapted for a Press Drill and Broadcast Sowing . . . . .	£	10	5
4	TWO FURROW PLOUGH . . . . .	£	10	5
5	THREE-FURROW PLOUGH . . . . .	£	10	5
6	DIGGING PLOUGH for light land	£	10	5
7	DIGGING PLOUGH for heavy land	£	10	5
8	ONE WAY PLOUGH . . . . .	£	10	5

**FARMS (£300).**

(Entries closed).

1	ARABLE and GRASS FARM of over 250 acres <sup>1</sup> . . . . .	£	80	40	20
2	ARABLE AND GRASS FARM, above 150 and not exceeding 250 acres <sup>1</sup>	£	60	40	-
3	ARABLE and GRASS FARM, above 50 and not ex- ceeding 150 acres <sup>1</sup> . . . . .	£	40	20	-

Last Day of Entry for Stock, Poultry, and Produce, APRIL 30, 1892.  
(Post Entries at Double Fees up to THURSDAY, MAY 12.)

The Regulations for these Prizes and for the Exhibition of Implements, &c. (for which entries close April 1, 1892) on application to the Secretary of the Society, at 12 Hanover Square, London, W.

**HIVES, HONEY, &c.**

Offered by British Bee-keeper's Assoc.

Class	Description	Prizes		
		1st	2nd	3rd
282	Collection of HIVES &c. . . . .	100	50	-
283	OBSERVATORY HIVE . . . . .	20	15	10
284	FRAME HIVE . . . . .	20	15	10
285	FRAME HIVE for Cottager's use . . . . .	20	15	10
286	HONEY EXTRACTOR . . . . .	15	10	-
287	PAIR OF SECTION RACKS . . . . .	15	10	5
288	RAPID FEEDER . . . . .	10	5	-
289	12 Sections of COMB HONEY, about 12 lb. . . . .	20	10	5
290	6 Sections of COMB HONEY, about 6 lb. . . . .	20	10	5
291	RUN OR EXTRACTED HONEY, about 12 lb. . . . .	20	10	5
292	12 Sections of COMB HONEY, about 12 lbs. gathered in or before 1891 . . . . .	20	10	5
293	RUN OR EXTRACTED HONEY, about 12 lbs. gathered in or be- fore 1891 . . . . .	20	10	5
294	GRANULATED HONEY, weight about 12 lb. . . . .	20	10	5
295	Display of HONEY . . . . .	50	30	10
296	USEFUL INVENTIONS introd. since 1890. } Special Prizes according to merit.			
297	Other Exhibits . . . . .			

**BUTTER-MAKING  
COMPETITIONS (£64).**

- CLASS 1. Open to United Kingdom.
- CLASS 2. Female Members of a Farmer's family not in service or working for wages.
- CLASS 3. Dairymaids in service who have never won a prize exceeding 1l.
- CLASS 4. Dairymaids residing in the Society's District F.

PRIZES: 1st 6l., 2nd 4l., 3rd 3l., 4th 2l., 5th 1l., in each class.

**HORSE-SHOEING  
COMPETITIONS (£32).**

(Limited to shoeing-smiths in the Society's District F.)

- CLASS 1. ROADSTERS.
  - CLASS 2. DRAY HORSES.
- PRIZES: 1st 6l., 2nd 4l., 3rd 3l., 4th 2l., 5th 1l., in each class.





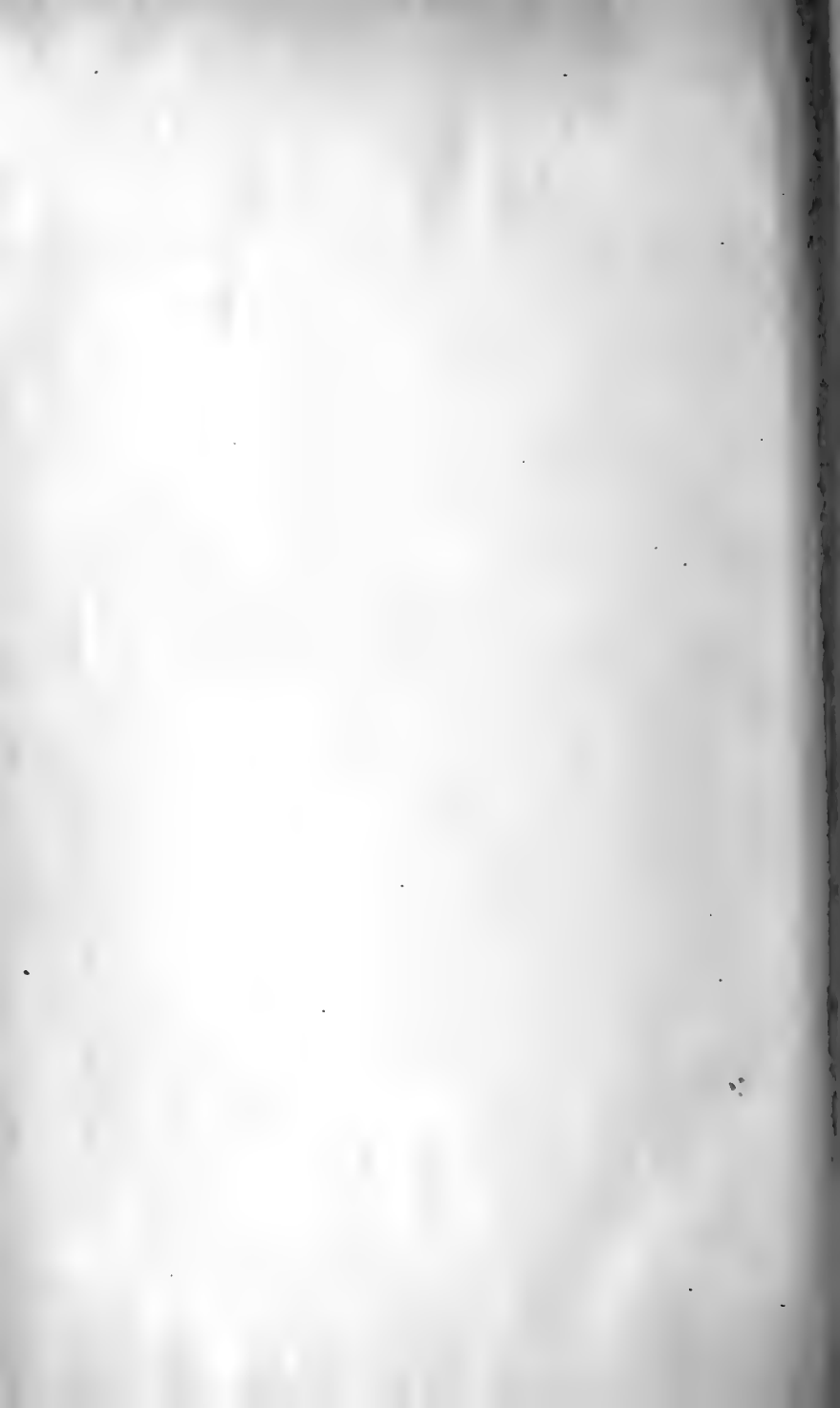

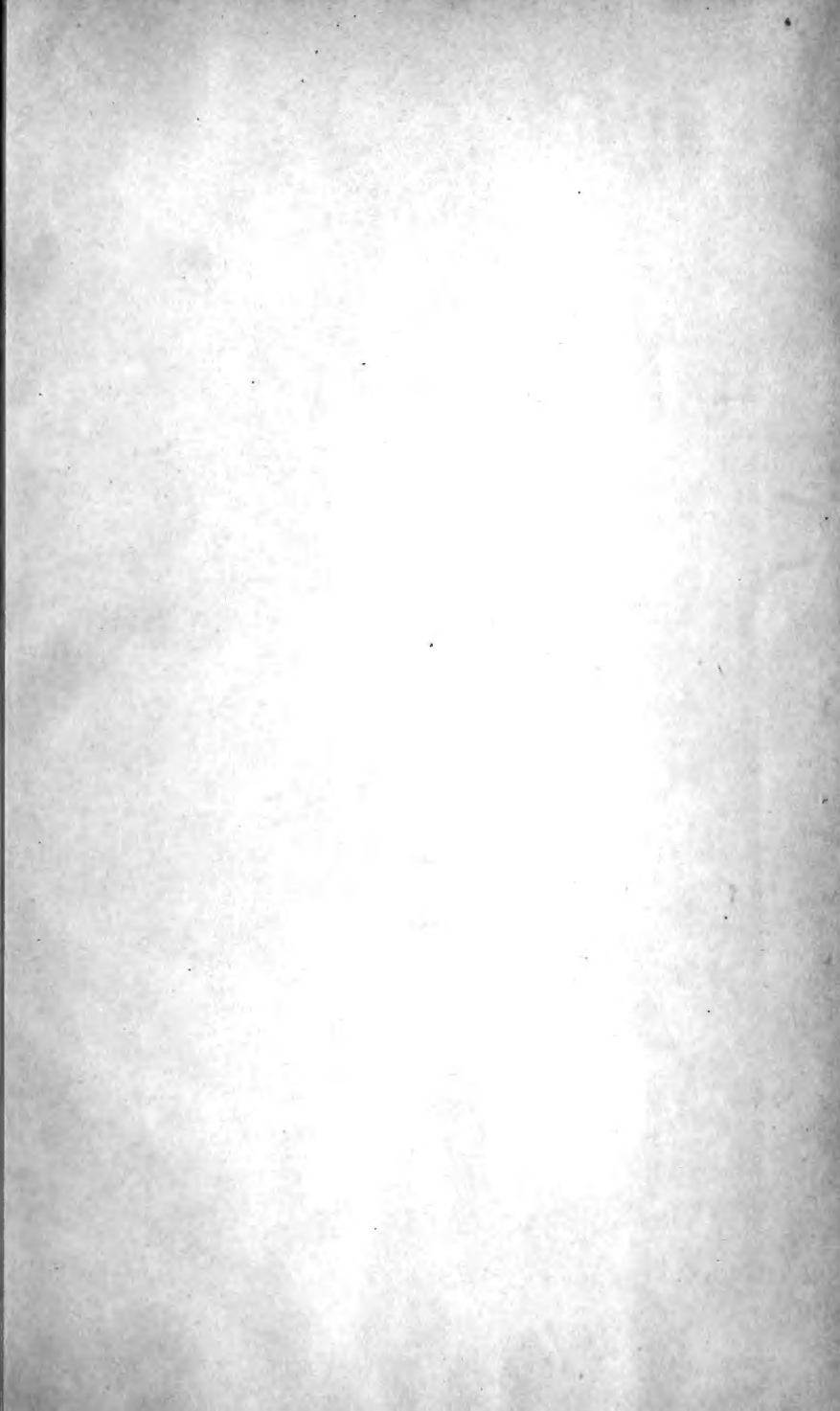

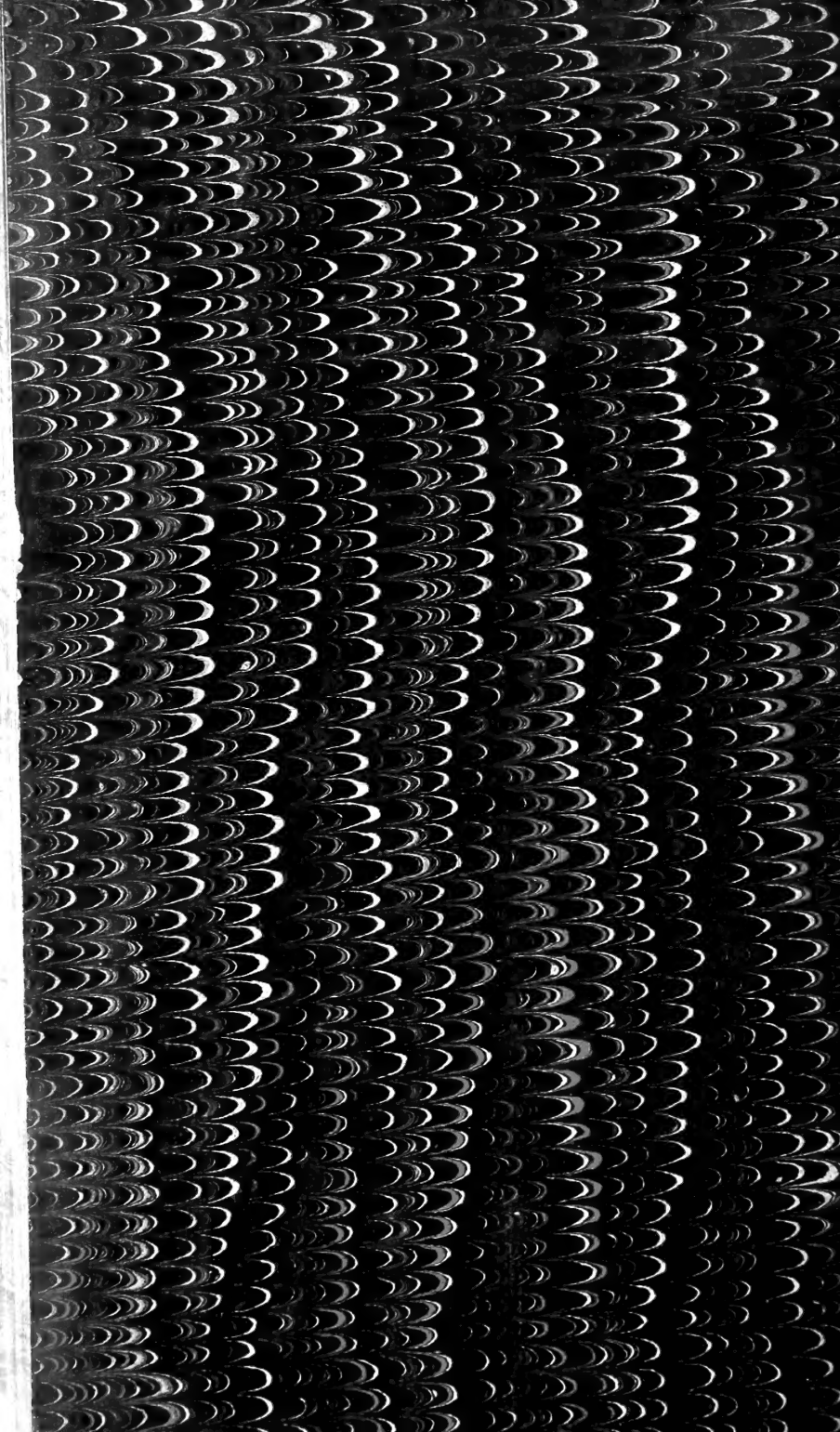

New York Botanical Garden Library



3 5185 00329 9862

