





# JOURNAL

OF THE

# WASHINGTON ACADEMY OF SCIENCES

---

VOLUME 41, 1951

---

## BOARD OF EDITORS

CHARLES DRECHSLER  
PLANT INDUSTRY STATION  
BELTSVILLE, MD.

WILLIAM F. FOSHAG  
U. S. NATIONAL MUSEUM

J. P. E. MORRISON  
U. S. NATIONAL MUSEUM

## ASSOCIATE EDITORS

J. C. EWERS  
ANTHROPOLOGY

C. W. SABROSKY  
ENTOMOLOGY

F. A. CHACE, JR.  
BIOLOGY

J. I. HOFFMAN  
CHEMISTRY

T. P. THAYER  
GEOLOGY

MIRIAM L. BOMHARD  
BOTANY

R. K. COOK  
PHYSICS AND MATHEMATICS

PUBLISHED MONTHLY

BY THE

WASHINGTON ACADEMY OF SCIENCES  
MOUNT ROYAL & GUILFORD AVES.  
BALTIMORE, MD.

ACTUAL DATES OF PUBLICATION, VOLUME 41

- No. 1, pp. 1-48, January 18, 1951  
No. 2, pp. 49-84, February 23, 1951  
No. 3, pp. 85-116, April 3, 1951  
No. 4, pp. 117-148, April 25, 1951  
No. 5, pp. 149-180, May 24, 1951  
No. 6, pp. 181-212, June 22, 1951  
No. 7, pp. 213-244, July 31, 1951  
No. 8, pp. 245-276, August 27, 1951  
No. 9, pp. 277-308, September 24, 1951  
No. 10, pp. 309-340, October 24, 1951  
No. 11, pp. 341-372, November 14, 1951  
No. 12, pp. 373-404, December 26, 1951

349716





06.73  
2W23  
Vol. 41

JAN 1951

No. 1

# JOURNAL

OF THE

## WASHINGTON ACADEMY OF SCIENCES

### BOARD OF EDITORS

FRANK C. KRACEK  
GEOPHYSICAL LABORATORY

FREDERICK J. HERMANN  
BUREAU OF PLANT INDUSTRY,  
SOILS, AND AGRICULTURAL  
ENGINEERING

WILLIAM F. FOSHAG  
U. S. NATIONAL MUSEUM

### ASSOCIATE EDITORS

LAWRENCE A. WOOD  
PHILOSOPHICAL SOCIETY

J. P. E. MORRISON  
BIOLOGICAL SOCIETY

ELBERT L. LITTLE, JR.  
BOTANICAL SOCIETY

CURTIS W. SABROSKY  
ENTOMOLOGICAL SOCIETY

JAMES S. WILLIAMS  
GEOLOGICAL SOCIETY

JOHN C. EWERS  
ANTHROPOLOGICAL SOCIETY

JAMES I. HOFFMAN  
CHEMICAL SOCIETY

PUBLISHED MONTHLY

BY THE

WASHINGTON ACADEMY OF SCIENCES

MOUNT ROYAL & GUILFORD AVES.

BALTIMORE, MARYLAND

Entered as second class matter under the Act of August 24, 1912, at Baltimore, Md.  
Acceptance for mailing at a special rate of postage provided for in the Act of February 28, 1925  
Authorized February 17, 1949



## Journal of the Washington Academy of Sciences

This JOURNAL, the official organ of the Washington Academy of Sciences, publishes: (1) Short original papers, written or communicated by members of the Academy; (2) proceedings and programs of meetings of the Academy and affiliated societies; (3) notes of events connected with the scientific life of Washington. The JOURNAL is issued monthly, on the fifteenth of each month. Volumes correspond to calendar years.

*Manuscripts* may be sent to any member of the Board of Editors. It is urgently requested that contributors consult the latest numbers of the JOURNAL and conform their manuscripts to the usage found there as regards arrangement of title, subheads, synonyms, footnotes, tables, bibliography, legends for illustrations, and other matter. Manuscripts should be typewritten, double-spaced, on good paper. Footnotes should be numbered serially in pencil and submitted on a separate sheet. The editors do not assume responsibility for the ideas expressed by the author, nor can they undertake to correct other than obvious minor errors.

*Illustrations* in excess of the equivalent (in cost) of one full-page halftone are to be paid for by the author.

*Proof.*—In order to facilitate prompt publication one proof will generally be sent to authors in or near Washington. It is urged that manuscript be submitted in final form; the editors will exercise due care in seeing that copy is followed.

*Unusual cost* of foreign, mathematical, and tabular material, as well as alterations made in the proof by the author, may be charged to the author.

*Author's Reprints.*—Reprints will be furnished in accordance with the following schedule of prices (approximate):

Copies	4 pp.	8 pp.	12 pp.	16 pp.	20 pp.	Covers
100	\$3.25	\$6.50	\$ 9.75	\$13.00	\$16.25	\$3.00
200	6.50	13.00	19.50	26.00	32.50	6.00
300	9.75	19.50	29.25	39.00	48.75	9.00
400	13.00	26.00	39.00	52.00	65.00	12.00

*Subscriptions* or requests for the purchase of back numbers or volumes of the JOURNAL or the PROCEEDINGS should be sent to HAROLD A. REHDER, Custodian and Subscription Manager of Publications, U. S. National Museum, Washington 25, D. C.

*Subscription Rates for the JOURNAL.*—Per year..... \$7.50

Price of back numbers and volumes:	Per Vol.	Per Number
Vol. 1 to vol. 10, incl.—not available.*	—	—
Vol. 11 to vol. 15, incl. (21 numbers per vol.)	\$10.00	\$0.70
Vol. 16 to vol. 22, incl. (21 numbers per vol.)	8.00	0.60
Vol. 23 to current vol. (12 numbers per vol.)	7.50	0.90

\* Limited number of complete sets of the JOURNAL (vol. 1 to vol. 40, incl.) available for sale to libraries at \$341.00

MONOGRAPH No. 1, "The Parasitic Cuckoos of Africa," by Herbert Friedmann. \$4.50

PROCEEDINGS, vols. 1-13 (1899-1911) complete..... \$25.00

Single volumes, unbound..... 2.00

Single numbers..... .25

*Missing Numbers* will be replaced without charge provided that claim is made to the Treasurer within 30 days after date of following issue.

*Remittances* should be made payable to "Washington Academy of Sciences" and addressed to the Treasurer, H. S. RAPPLEYE, 6712 Fourth Street, N.W., Washington 11, D.C.

*Exchanges.*—The Academy does not exchange its publications for those of other societies.

JOURNAL  
OF THE  
WASHINGTON ACADEMY OF SCIENCES

VOLUME 41

January 1951

No. 1

✿  
A U S T I N   H O B A R T   C L A R K   I S S U E  
✿

DEDICATION

THE PAPERS appearing in this issue of the JOURNAL are written by friends and colleagues of Austin Hobart Clark and form a slight token of their respective authors' regard for him and for his work.\* As may be seen from their contents, the papers cover a wide range of material and interests. This is eminently as it should be, for few biologists of our time have embraced within the extent of their knowledge and the scope of their sympathies so many and such diverse portions of the fauna and flora of the world. Although his main published works deal with the echinoderms, and particularly with the crinoids, his bibliography includes many and important contributions to our knowledge of birds, of butterflies, of *Peripatus*, of flowering plants, and even of topics so difficult to classify and pigeonhole as "general natural history." He was for long a leading figure in the popularization of natural history and a prolific contributor to its literature, as witnessed by his two little volumes of *Nature narratives*. He was a pioneer in the now widespread use of current scientific data and materials by the newspapers and was one of the first to sense the application of the radio to the dissemination of scientific news and thoughts. For many years he served as the press and publicity official for the American Association for the Advancement of Science, and he did much to build up the techniques of "science reporting" in this country.

To his colleagues he was, and is, a man to whom anyone could converse about his own pet specialty or even tangential interest with the assurance not only that he would be understood but also that it would elicit some stimulating and thought-provoking comment from him. An unusually broad acquaintance with the forms of living things and a remarkably retentive memory for the literature about them have given Clark the background for such books as his *Animals of land and sea* and *Animals alive*, while his lively curiosity about them conditioned his thinking as expressed in his book on *Zoogenesis*.

When a man attains the age at which his colleagues think of expressing publicly their esteem of him, it is often assumed that he is about to merge gracefully with the ghosts of the forerunners of his particular science. I am confident that none of his many friends have any such thought in mind. Those who know him best are aware that his mind is far too active to assume a passive status and feel that were he to become a ghost he would probably lose no time in organizing among his fellow spirits a new society for the cultivation of scientific interests.

HERBERT FRIEDMANN.

\* See note on page 48.

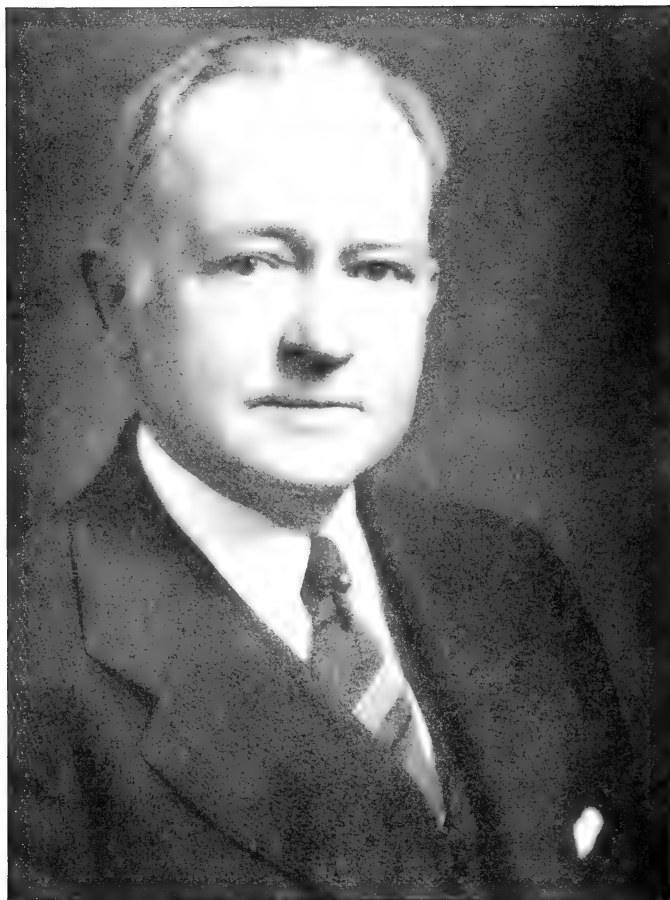

AUSTIN HOBART CLARK

ZOOLOGIST, BIOLOGIST, NATURALIST  
AUTHORITY ON ECHINODERMS, PARTICULARLY THE CRINOIDEA  
SCIENCE WRITER AND AUTHOR

**Born** at Wellesley, Mass., December 17, 1880; prepared for college in the high school and in Cutler's School, Newton, Mass.; entered Harvard in 1899, graduated with A.B. degree in 1903.

**Member** of the Washington Academy of Sciences since April 8, 1912; has been one of its most indefatigable workers and staunchest supporters over the years; president in 1941 and before and since that time vice-president representing two of the affiliated societies, Archeological in 1922, 1923 and Entomological, 1936, 1939-1944; member of the Board of Managers 1926-28, Committee on Meetings 1920-21, 1938, 1939, Committee on Membership 1934, 1938, Committee on Awards for Scientific Achievement (first general chairman) 1940, Subcommittee on Awards in Biological Sciences 1940, 1943, Committee on Policy and Planning 1941-51, Committee on Encouragement of Science Talent 1950-52.

**Chief interest**, animal life. This, he tells us, began about at the age of 10. Already in 1898 he was abroad a year "getting acquainted with European creatures," and in the following summer he learned to know more of the American ones in the mountains of Tennessee. Two years later, at the head of a personally organized expedition, he was investigating the flora and fauna of Margarita Island, Venezuela; the published results led to his election as a fellow of the Royal (London) Geographic Society in 1904. Following graduation from college in 1903, after a brief sojourn at the then newly established Bermuda biological station, he spent two years exploring the Lesser Antilles. Thereafter, joining the U. S. Bureau of Fisheries, he served as naturalist on the 1906 cruise of the Fisheries steamer *Albatross* to Japan.

**Professional career:** Collaborator (honorary), United States National Museum 1908; assistant curator, Division of Marine Invertebrates 1909-20; curator, Division of Echinoderms 1920-50; retired December 31, 1950; in 1923 established a series of weekly radio talks given in the name of the Smithsonian Institution.

**Affiliations:** American Association for the Advancement of Science (news manager and director press service, 1924-29; in charge radio programs, centennial meeting, Washington, D. C., 1948); International Committee on Radio (Comité International de la T.S.F.); American Geophysical Union (chairman for Oceanographic Section); Advisory Committee on Source Bed Studies of the American Petroleum Institute and American Association of Petroleum Geologists; American Association of Museums; Carnegie Corporation and Rockefeller Foundation Conference on Place of Science in Education; Virginia Academy of Science; (2d honorary member; committee on long-range planning and science education); Executive Committee of the Southern Association of Science and Industry; Eighth American Scientific Congress (press relations officer); National Parks Association (trustee); Navy Oceanographic Conference (1924); National Association of Science Writers (first honorary member); American Society of Naturalists; American Ornithologists' Union; Lepidopterists Society (vice-president); Biological Society of Washington; Entomological Society; Cambridge (Massachusetts) Entomological Club; aide-de-camp to the Prince of Monaco during the latter's visit to this country in 1921. In 1927 His Majesty, the King of Denmark and Iceland, conferred upon Austin Clark the Cross of a Knight of the Order of Dannebrog.

**Author** of more than 650 papers, treatises, and books, technical and popular, chiefly in the field of zoology, marine biology, oceanography, and natural history, crinoids, echinoderms, birds, and Lepidoptera.

**Publications** especially worthy of mention are: *A Monograph of the existing crinoids; The new evolution—Zoogenesis; Nature narratives; Butterflies of the District of Columbia; Animals of land and sea; Animals alive.*

**Married** Mary Wendell Upham 1906, deceased 1932; children, two sons, three daughters; 6 grandchildren. Married, Leila Gay Forbes, 1933.

W. L. S.

PALEONTOLOGY.—*New brachiopods from the Lower Cambrian of Virginia.*<sup>1</sup>

G. ARTHUR COOPER, U. S. National Museum.

The brachiopods described and figured herein were collected by several geologists during investigations of the geology about Austinville, Va. The first lot of material was collected by W. Horatio Brown, chief geologist for the New Jersey Zinc Co. at the Bertha Mineral Co. in 1929. Later collections were made by Charles Butts, E. O. Ulrich, George W. and Anna J. Stose, and Charles E. Resser. Most of the brachiopods were too poorly preserved to be recovered from the matrix in identifiable form, but from the large quantity of material collected it was possible to prepare a few first-rate specimens.

The chief obstacle to successful preparation of the specimens was tight cementation to the limestone matrix enclosing them. Several were destroyed in attempting to split them out of the matrix, because the pedicle valve posterior always failed to crack away from the surrounding rock. The same was true after the rock was roasted and plunged in cold water. The anterior and lateral parts of pedicle valves were released, but perfect beaks were never obtained. The reason for this difficulty proved to be a large foramen near the apex through which the filling of the inside was joined to the matrix outside the shell. After this discovery several specimens were cleaned that showed the large apical foramen, which is of considerable interest in brachiopod taxonomy.

These new genera occur in a reef limestone in the Lower Cambrian (Shady) formation with the brachiopods *Kutorgina*, *Nisusia*, *Swantonina*, and *Yorkia*. Characteristic Lower Cambrian trilobites occurring in the same rock are: *Kootenia*, *Rimouskia*, *Bonnina*, and *Labradoria*. These clearly fix the age of the peculiar forms here discussed.

The two species herein described are named in honor of Austin H. Clark in recognition of his great contributions to taxonomy and biology.

*Eoconcha*, n. gen.

Shell spiriferoid in appearance, strongly and subequally biconvex, with a wide hinge that may

or may not form the greatest shell width; brachial valve sulcate; pedicle valve with a low median fold; surface marked by strong direct and intercalated costae.

Palintrope of pedicle valve well developed, generally apsacline; delthyrium covered by a convex pseudodeltidium; foramen moderately large, located at or anterior to the apex as in *Nisusia*. Teeth small, inconspicuous, forming by their forward growth a marginal thickening along lateral edges of delthyrium; dental plates absent.

Brachial valve with flattened brachiophores located under the notothyrial edge and without supporting plates as in *Nisusia*. Seat of diductor muscle attachment a small callosity located at the apex of the notothyrial cavity. Muscular (adductor) scar elongate, located in front of notothyrial callosity on each side of median line.

Genotype: *Eoconcha austini*, n. sp.

*Discussion.*—The internal characters of this genus are essentially the same as those of *Nisusia* with the exception that in the latter a trace of dental plates has been detected (Cooper,<sup>2</sup> p. 213). Thus the generic definition of this peculiar brachiopod is based mainly on the external features. Although the nature of the pseudodeltidium and palintropes is like that of *Nisusia* the ornamentation, profile and folding are different. The ornamentation of *Eoconcha* consists of simple, strong costae that extend from the beak to the anterior margins or may be intercalated at the front or middle of the shell. The characteristic spines of the *Nisusia* exterior are not present in this new genus.

The brachial valve is provided with a fairly deep median sulcus while the pedicle valve has a more or less well-defined fold. The presence of a sulcus on the brachial valve is a feature common to geologically early or immature brachiopods particularly those of the Orthacea. The brachial sulcus is here regarded as a primitive character.

The actual apical foramen in the specimen on which this genus and species is based was not seen except in one specimen. It is inferred in the others from the fact that the beaks of all pedicle valves are broken away. This is a common feature also of specimens of *Nisusia* similarly preserved.

<sup>2</sup> COOPER, G. A. *New Cambrian brachiopods from Alaska*. Journ. Paleont. 10 (3): 210-214, pl. 26. 1936.

<sup>1</sup> Received October 6, 1950.

*Eoconcha austini*, n. sp.

Biconvex, wider than long, with the hinge forming the widest part or narrower than the midwidth; cardinal extremities acutely or obtusely angular. Surface costate with 9-13 costae.

Pedicle valve moderately convex to subpyramidal in lateral profile, strongly and somewhat narrowly rounded in anterior profile; median fold originating posterior to the middle, not greatly elevated above the surface of the valve and composed of one to three costae. Lateral slopes convex and moderately steep. Beak obtuse; interarea moderately long, apsaeline.

Brachial valve moderately convex in lateral profile and more broadly convex than the pedicle valve in anterior profile. Sulcus shallow, narrow, extending from beak to anterior margin and usually occupied by one costa which is depressed below the two strong costae bounding the sulcus. Flanks with moderately steep slopes to the cardinal extremities.

*Measurements in mm.*—Pedicle valve (U.S.N.M. no. 111691-a), length 9.2, midwidth 12.0, hinge-width 11.7; (111691-e) length 10.3, midwidth 12.9, hinge-width 12.7, thickness about 5. Brachial valves (111691-i) length 9.8, midwidth 15.4, hinge-width 13.9, thickness 3.9?; (111691-k) length 9.4, midwidth 13.7, hinge-width 15.4?, thickness 4.1?

*Types*—Holotype, U.S.N.M. no. 111691-a; figured paratypes, U.S.N.M. nos. 111691-d, f, g, h, k, m; unfigured paratypes, U.S.N.M. nos. 111691-b, c, e, i, j, l.

*Horizon and locality.*—Shady formation, 1 mile east of Austinville, Max Meadows quadrangle, Va.

*Discussion.*—The strong costae of the exterior distinguish this from any known species of *Nisusia*. No other species of *Eoconcha* is now known.

*Matutella*, n. gen.

Shell fairly large, syntrophoid in profile and outline; brachial valve strongly uniplicate, pedicle valve deeply sulcate; hinge wide; ornamentation consisting of irregular intercalated and bifurcating costellae.

Pedicle umbo pierced by a large longitudinally oval foramen; palintrope short, delthyrium moderately wide, covered by a convex pseudodeltidium. Dental plates absent. Diductor scars flabellate.

Brachial valve with long flat palintrope with exceptionally broad interarea; notothyrium wide, other details of the interior uncertain.

Genotype: *Matutella clarki*, n. sp.

*Discussion.*—This genus is quite unlike any other known Paleozoic brachiopod in the extent to which the foramen is developed. This wide foramen existing with a delthyrium covered by a convex pseudodeltidium suggests relationship to the members of the *Nisusidae*. *Matutella* differs from *Nisusia* and *Eoconcha* in the exceptionally large foramen and the syntrophoid shape and form of the valves. It differs further from *Eoconcha* in having the high fold on the brachial valve and the deep sulcus on the pedicle valve.

This unusual brachiopod combines primitive and advanced characters to form a paradoxical genus. The external form is that of one of the later brachiopods such as *Syntrophina*, *Platystrophia*, or a narrow-hinged spiriferoid. Casual inspection has led observers to regard specimens as of later age than the Cambrian, so unusual is its form. The strong convexity of both valves is an unusual feature for an early brachiopod. Along with the convexity, as an advanced character, is the deep folding of both valves and the localization of the fold to the brachial valve. In contemporary *Nisusia* the folding is not standardized as it is in *Matutella*, the same species often showing a faint fold or sulcus on the pedicle or brachial valve. This lack of stability in folding is a primitive character whereas the strong localization of the fold to the brachial valve is a feature that has become fixed in most of the advanced members of the Proteromata.

Although the folding is that of an advanced brachiopod the ornamentation of *Matutella* is primitive in its lack of standardization and the wavy character of the costellae.

The most unusual feature of the genus is the large foramen that occupies nearly or all of the strongly convex umbo. The beak is located at the narrow end of the oval and is thickened and strengthened at this point. The foramen varies in size on four specimens from 3 by 2 mm to 5 by 3½ mm. So far as can be observed the shell is not noticeably thickened around the margins of the foramen except in the vicinity of the beak.

The interarea of the pedicle valve of *Matutella* is like that of most brachiopods having this form and convexity. It is short, curved generally orthocline or anaeline. The teeth are small and

located at the basal angles of the delthyrium as usual in most brachiopods. The pseudodeltidium is narrowly elevated and considerably thickened from the inside and very effectively covers the delthyrium. The latter obviously did not serve as a pedicle opening in this genus. Much of the shell of *Matutella* was so thin that mere traces of the musculature occur on any of the specimens where the valves have been exfoliated. Faint markings that are possible flabellate diductors occur on internal impressions on the antero-lateral extremities on each side of the foramen.

The thin shell and poor preservation combine to make preparation of internal characters of the brachial valve almost impossible. The palintrope of this valve is quite unusual in its length and breadth. It is usually deeply striated parallel to the hinge-line by interruptions in growth. The notothyrium is wide but on its margins the characteristic thickenings of brachiophores were not seen on any of the specimens nor were any well-defined sockets seen. One specimen indicates the rudiments of a childium in an upward wave of the palintrope at the beak. The musculature is as indefinite as the rest of the structures of this valve. Several exfoliated specimens show vague markings suggesting the musculature of the brachial valve of *Nisusia*.

*Matutella clarki*, n. sp.

Shell large for a Cambrian genus, wider than long, with the hinge slightly less than the greatest shell width, which is located a short distance

anterior to the middle. Cardinal extremities obtuse or nearly rectangular with small ears on pedicle valve. Sides moderately convex; anterior commissure strongly uniplicate. Surface marked by narrowly rounded radiating but irregular costellae which fade out on the cardinal extremities. Costellae increasing by bifurcation and intercalation. Fine concentric growth lines over the entire shell.

Pedicle valve moderately convex in lateral profile but with the umbonal region truncated by the foramen; anterior profile deeply sulcate; sulcus originating slightly anterior to the foramen, deepening and widening rapidly to equal about half the width of the valve; sulcus extended toward the brachial valve into a long and sharply pointed tongue bent nearly at right angles to the lateral commissure. Flanks bounding sulcus narrowly rounded in anterior profile with steep slopes to the cardinal extremities. Interarea short, about orthocline in position. Beak small incurved; foramen large and longitudinally elliptical.

Brachial valve gently convex in lateral profile, most noticeably convex in the umbonal region; anterior profile almost semicircular but with flattened top; fold originating less than one-third the length from the beak, narrowly rounded to subcarinate and most strongly elevated at anterior. Flanks bounding fold gently rounded and with steep slopes to the sides and cardinal extremities. Interarea long, orthocline (?).

*Measurements in mm.*—Holotype, pedicle valve, length 13.4, width at middle 17.6, hinge-

FIGS. 1-3.—*Nisusia borealis* Cooper: 1, Apical view of young pedicle valve showing elevated pseudodeltidium and large foramen,  $\times 3$ , U.S.N.M. no. 91903-a; 2, 3, respectively posterior and apical views of an incomplete adult pedicle valve,  $\times 4$ , showing elevated pseudodeltidium, hypotype, U.S.N.M. no. 111692. Introduced for comparison with *Eoconcha* and *Matutella*.

FIGS. 4-7, 9-14.—*Eoconcha austini* Cooper, n. gen., n. sp.: 4, Posterior view of an impression of the interior of a pedicle valve showing convex pseudodeltidium and thickening along delthyrial edge representing growth track of teeth,  $\times 2$ , paratype, U.S.N.M. no. 111691-d; 5, impression of apex of pedicle valve showing convex pseudodeltidium,  $\times 2$ , holotype, U.S.N.M. no. 111691-a; 10, 11, posterior and apical views of a wax replica of the pedicle valve prepared from impression illustrated in Fig. 5 (shows pseudodeltidium and foramen, the latter imperfectly,  $\times 2$ ); 6, 7, respectively posterior and brachial views of the impression of a brachial valve,  $\times 2$ ,  $\times 1\frac{1}{2}$ , showing impression of brachiophores, paratype, U.S.N.M. no. 111691-g; 9, posterior view of an internal impression of a pedicle valve showing fractured apex indicating presence of open foramen,  $\times 1$ , paratype, U.S.N.M. no. 111691-m; 12, wax replica of interior of a brachial valve showing primitive brachiophores,  $\times 2$ , paratype, U.S.N.M. no. 111691-h; 13, impression of a brachial valve showing costae,  $\times 2$ , paratype, U.S.N.M. no. 111691-k; 14, impression of brachial interior showing probable adductor muscle impressions,  $\times 2$ , paratype, U.S.N.M. no. 111691-f.

FIGS. 8, 15-27.—*Matutella clarki* Cooper, n. gen., n. sp.: 8, Pedicle interarea showing rounded pseudodeltidium,  $\times 2$ , paratype, U.S.N.M. no. 111689-c; 19, 25, exterior of two pedicle valves,  $\times 1$ , respectively holotype, U.S.N.M. no. 111689-a, and paratype, U.S.N.M. no. 111689-d; 15, 23, 24, respectively anterior, exterior, and posterior views of the pedicle valve,  $\times 2$ , paratype, U.S.N.M. no. 111689-d; 16, exterior of a large but imperfect brachial valve,  $\times 2$ , paratype, U.S.N.M. no. 111689-k; 17, Imperfect brachial valve showing ornamentation,  $\times 2$ , paratype, U.S.N.M. no. 111689-g; 18, 23, respectively posterior and exterior views of the holotype,  $\times 2$ , showing foramen and ornamentation; 22, fragment of exterior enlarged to show details of costella,  $\times 3$ , paratype, U.S.N.M. no. 111689-e; 21, 26, 27, respectively side,  $\times 1$ , internal impression, and exterior views of a brachial valve,  $\times 2$ , paratype U.S.N.M. no. 111689-n. (Fig. 27 is a wax replica of the exterior taken from an impression of the exterior.)



width 13.1, width of sulcus 9.6, thickness 3.7. Brachial valve (U.S.N.M. no. 111689-n) measured on half specimen, then doubled to obtain approximate measurements, length 13.2, mid-width 17.2, thickness 9.2.

*Types*.—Holotype, U.S.N.M. no. 111689-a; fig-

ured paratypes, U.S.N.M. nos. 111689-c, d, e, g, k, n; unfigured paratypes, U.S.N.M. nos. 111689-b, f, h, i, j, l, m, o.

*Horizon and locality*.—Shady formation (reefs), Buddle Branch,  $\frac{3}{4}$  mile northeast of Austinville, Max Meadows quadrangle, Va.

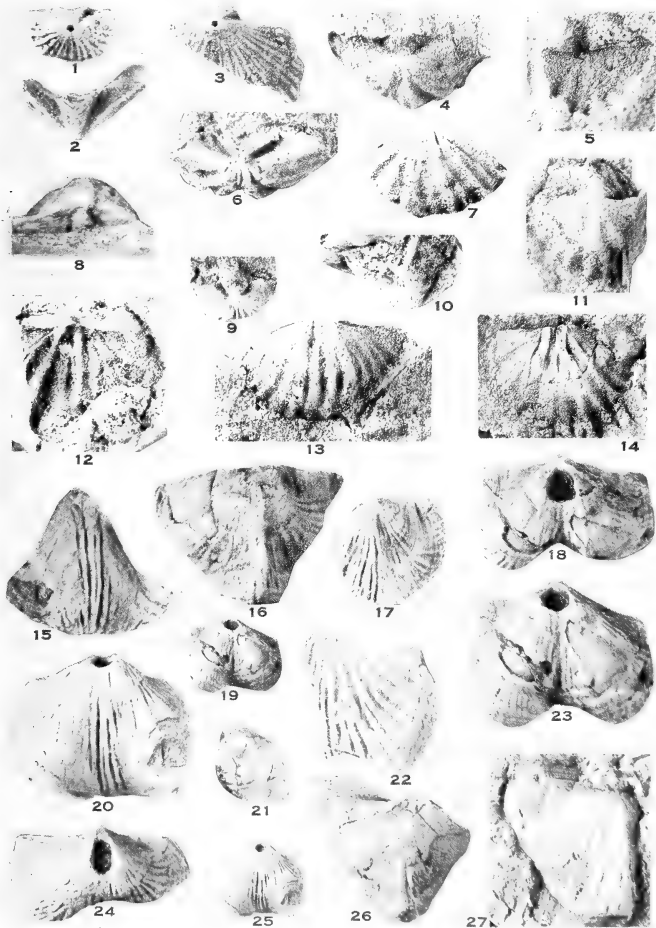

FIGS. 1-27.—(See opposite page for legend).

## DISCUSSION OF THE GENERA

The brachiopods discussed herein are of considerable interest because they are obviously highly specialized along certain lines, yet they are among the earliest of known articulate brachiopods. They are thus primitive but highly specialized brachiopods. *Paterina* was regarded by Beecher and Schuchert as the most primitive brachiopod and the one nearest the theoretical brachiopod progenitor. Inasmuch as these peculiar shells from Virginia occur with the primitive *Paterina*, they have an interesting and significant importance in brachiopod taxonomy and phylogeny. They help to emphasize the fact that in the articulates the pseudodeltidium is a primitive feature, whereas the unmodified delthyrium is an advanced character. They also indicate that the articulates must have a long ancestry in the pre-Cambrian. *Paterina* itself must be considered as an early but highly specialized brachiopod. Its structure is so unusual that it must be ruled out as near the progenitor of the brachiopods. The most primitive shelled brachiopod is yet to be found.

Although the presence of a pseudodeltidium is an accepted primitive character in articulate brachiopods, it has not been sufficiently emphasized that an apical foramen is also a primitive character. The foramina of the genera herein described and of *Nisusia* differ from those of later genera having an apical foramen in the size and location of the opening. In these early Cambrian genera such as *Nisusia* the foramen is excavated

in the pedicle umbo rather than in the apex, a position that is seldom occupied by a foramen other than the type produced by anterior pedicle migration in the later brachiopods. This is especially true of *Matutella* with its strongly arched beak the umbo of which is truncated by a large oval foramen. This foramen is quite unlike any other known and is not produced by resorption of the beak due to pedicle pressure as often takes place in the Terebratulacea. A foramen like that of *Nisusia* occurs in later brachiopods in the young of many Strophomenidae such as *Leptaena*, *Strophomena* and *Christiania* in which extremely youthful shells have the apex occupied by a large foramen. Although the young of the Strophomenidae are often *Nisusia*-like in their appearance it is not at present possible to derive this group out of *Nisusia* for the simple reason that the first unquestioned strophomenid, *Taffia*, occurs in the Upper Canadian. No forms are known that bridge the long time gulf between the two.

Cambrian Articulate brachiopods are too poorly known to state whether or not *Nisusia* and allies disappeared without issue. The known later Cambrian brachiopods are either without apical foramina, have an open delthyrium (*Eoorthis*) or have the foramen confined to the deltidium (*Billingella*). For the present it is best just to emphasize the fact that the earliest known Articulates had a more or less large foramen situated on the pedicle umbo anterior to the apex of the pseudodeltidium or truncating the apex because of pedicle pressure.

PALEONTOLOGY.—*Two new guide fossils from the Tallahatta formation of the Southeastern States.*<sup>1</sup> JULIA GARDNER, U. S. Geological Survey.

Though the name of Austin Hobart Clark is most closely associated with echinoderms, butterflies, and birds, most of us who have frequented the United States National Museum for the past few decades have, from time to time, sought Mr. Clark's aid on problems in our own particular fields, and not in vain. All animals alive are his interest, even *Homo sapiens*. The two species about to be inscribed to him are long since dead,

to be sure, but the inscription does not seem inappropriate, for as Mr. Clark has served as our guide, philosopher, and friend, helping us to orient ourselves and to check our positions in the world about us, so wavering students coming upon these fossils may find them dependable guides to the Tallahatta formation of the middle Eocene, usually to the upper part of the Tallahatta.

Genus *Anodontia* Link, 1807

*Anodontia* Link, Beschreibung der Naturalien-Sammlung der Universität zu Rostock, pt. 3: 157. 1807.

<sup>1</sup> Published by permission of the Director, U. S. Geological Survey, Received October 6, 1950.

Type by monotypy: *Anodontia alba* Link = *Venus edentula* Linnaeus.

Link styled his genus the *Glattmuschel* and briefly characterized it as: Equivalve, the valves closed, without ears; the hinge without teeth; the anterior muscle scar much longer than the posterior; the ligament external. He cited two references—Chemnitz's *Conchylien-Cabinet* 7: pl. 39, figs. 410 and 411, which illustrate a venerid; and the Gmelin of Linnaeus, p. 3286. Figures 408 and 409 of plate 39 of Chemnitz illustrate the "Venus of Jamaica" and figures 427 to 429 on plate 40, *Venus edentula*. The mechanics of the typographical error that resulted in the reference as it appeared in Link are difficult to reconstruct. The explanation suggested by Stewart (pp. 179–180)<sup>2</sup> forced him to the unhappy necessity of

<sup>2</sup> STEWART, RALPH B., *Gabb's California Cretaceous and Tertiary type lamellibranchs*, Acad. Nat. Sci. Philadelphia Spec. Publ. no. 3, 314 pp., 17 pls. 1930.

designating *Lucina jamaicensis* Lamarek as the genotype. A simpler interpretation was offered in a discussion with Dr. Harald A. Rehder, Curator of mollusks in the United States National Museum. He suggested that Link may never have even seen the *Conchylien-Cabinet*, that he took the reference to Chemnitz directly from Gmelin, but that in so doing his eye slipped up the page and he copied the notation under the preceding species, *V. scripta* (pl. 39, figs. 410–411) in place of that under *Venus edentula* (pl. 40, figs. 427–429). That solution is here accepted.

*Anodontia? augustana* Gardner, n. sp.

Fig. 1, a–e

Shells large, most commonly represented by globose molds of the interior, broader than they are high and subject to distortion by a shortening along the vertical axis; in the normal shells, the distance from the beaks to the ventral margin is



FIG. 1.—*Anodontia? augustana* Gardner, n. sp.: a, Side view of right valve of holotype; b, umbonal view of double valves of holotype; c, hinge of incomplete paratype (U.S.N.M. no. 560588); d, fragment of hinge of paratype (U.S.N.M. no. 560590); e, exterior of broken anterior dorsal margin (U.S.N.M. no. 560590). All natural size.

only a little more than the diameter. In place of a lunule, a flaring anterior margin, reflected over the umbones somewhat in the manner of the pholads. Shell flattening toward the posterior dorsal margin but no defined escutcheon. Hinge edentulous. Ligament groove deep, the ligament conspicuous, and in some of the larger specimens arching above the escutcheon; ligament and resilium may have been partially separated. Muscle scars not traceable in any of the shells available. Obscure radiating lines, about six to the centimeter, evident on molds of interior. No defined sculpture pattern on exterior of shell but an irregular concentric wrinkling over the entire outer surface.

Dimensions of holotype, an interior mold of paired valves with fragments of shell adhering: Height, 60 mm; width, 78 mm; diameter, 57 mm. Paratypes too fragmentary to measure.

*Holotype*, U.S.N.M. no. 560587, from Lisbon Bluff, Alabama River, 3 feet or less below the contact of the Tallahatta and Lisbon formations, Monroe County, Ala. Paratype (Fig. 1, *c*), U.S.N.M. no. 560588, from U.S.G.S. station 15159, Fort Gaines-Abbeville road just south of the bridge over McRae Creek, Henry County, Ala. Paratype (Fig. 1, *d-e*), U.S.N.M. no. 560590, from U.S.G.S. station 15475, south slope to Little Choctawatchee River, on State Highway 66, Houston County, Ala.

The upward flare of the anterior dorsal margin is unlike that of any known Recent or fossil lucinoid and probably is a character of more than specific value. But the material is so limited and so fragmentary that, awaiting further evidence, the species is referred to *Anodontia* sensu lato.

*Anodontia? augustana* must have been a fragile shell and in need of protection through the environment. It probably lived on soft muddy bottoms near the mouths of rivers and in sheltered bays in water of shallow or only moderate depths sheltered from strong current action. Such bottom conditions are reflected in the fine silicified clays of the so-called Buhrstone of the Tallahatta formation.

*Anodontia augustana* has been recorded from the following U.S.G.S. stations:

No number. NW $\frac{1}{4}$  sec. 34, T. 11 N., R. 2 W., east of Toxey, Choctaw County, Ala.

17919. Little Stave Creek, directly below Tallahatta-Lisbon contact; about 4 $\frac{1}{2}$  miles north of Jackson, Clarke County, Ala.

14785-g. Little Stave Creek, between 5 and 10 feet

below Tallahatta-Lisbon contact; about 4 $\frac{1}{2}$  miles north of Jackson, Clarke County, Ala.

15924. Contact of siliceous clay and overlying greensand, 3 miles northeast of Chilton on Thomasville road, Clarke County, Ala.

15925. Long slope leading down to Silver Creek about 6 miles west-southwest of Chance on Dickenson road, Clarke County, Ala.

15920. About 1 $\frac{1}{2}$  miles west of Chance on Dickenson road, Clarke County, Ala.

17090. Lisbon Bluff, Alabama River, 3 feet or less below the Tallahatta-Lisbon contact, Monroe County, Ala. Type locality.

13442. Lisbon Bluff, Alabama River, within 10 feet of Tallahatta-Lisbon contact, Monroe County, Ala.

13441. Lisbon Bluff, Alabama River, within 10.5 feet of Tallahatta-Lisbon contact, Monroe County, Ala.

15132. Railroad cut in south center of sec. 14, T. 8 N., R. 8 E., Monroe County, Ala.

15480. East bank of Conecuh River about 200 yards above highway bridge at River Falls, Covington County, Ala.

11091. Hays Creek at Bedsole's old mill road from Elba to Kinston, S $\frac{1}{2}$  sec. 15, T. 4 N., R. 19 E., Coffee County, Ala.

15159. Road cut on Fort Gaines-Abbeville road just south of the bridge over McRae Creek, center sec. 12, T. 17 N., R. 29 E., Henry County, Ala.

15475. South slope to Little Choctawatchee River in road cut on new State Highway 66, SE $\frac{1}{4}$  sec. 34, T. 4 N., R. 24 E., Houston County, Ala. Shells silicified.

7728. Warley Hill, 7 miles southeast of Fort Motte on Lonestar road, Calhoun County, S. C. A mold 92 mm wide from Bed No. 8 of Cooke section.

No number. Road cut on South side of Halfway Swamp Creek about 2 $\frac{1}{4}$  miles northwest of Creston, Calhoun County, S. C. A mold 140 mm wide from the Congaree clay of Sloan.

#### Genus *Spiratella* de Blainville, 1817

*Spiratella* de Blainville, Dictionnaire des sciences naturelles 9: 407. 1817. = *Limacina* Lamarck, 1819.

Type by original designation and monotypy: *Clio helicina* Phipps (exceedingly abundant in Arctic waters).

#### *Spiratella augustana* Gardner, n. sp.

Fig. 2, *a-c*

Shell very small. Whorls 4 to 4 $\frac{1}{2}$ , sinistrally coiled in a nearly horizontal plane, the body embracing the whorls of the spire as in *Planorbis*. The aperture higher than it is wide, the body expanding at the aperture both vertically and hor-

izontally; the outer surface of the preceding whorl forming the inner wall of the aperture; posterior margin of the body folded into the suture. The visible surface of the apical whorls rounded, scarcely elevated above the plane of the body. Umbilical area narrowly funicular. No sculpture other than obscure incrementals and the cording of the adult margin of the outer lip.

Dimensions of holotype, U.S.N.M. no. 560589: Maximum diameter, 3 mm; diameter at right angles to the maximum diameter, 2.6 mm; minimum diameter 2.3 mm; height, 1.5 mm.

Type locality: U.S.G.S. station 17911, between 15 and 20 feet below the contact of the Tallahatta and Lisbon formations and 4 feet above the stream bed of Little Stave,  $4\frac{1}{2}$  miles north of Jackson, Clarke County, Ala.

Even the ordinal relationships of these shells resembling small sinistral *Planorbis* and locally common in the marine faunas of the upper Tallahatta baffled me. I sought the guidance of that dean of malacologists, Dr. Henry A. Pilsbry, and to good purpose. I am grateful to him for his never-failing aid.

The species I described in 1927 as *Planorbis andersoni*<sup>3</sup> is doubtless closely related, though not identical. The Texas form is smaller, which may or may not be significant. It is also more compressed and is more regular in form. The outer lip is less expanded, and the body whorl, both on the apical and umbilical surfaces, is rather sharply keeled. The locality, U.S.G.S. station 9264, three-fourths of a mile south of Elkhart, Anderson County, Tex., is in the Weches greensand member of the Mount Selman formation, which correlates roughly with the Tallahatta formation.

The range of variation in these small forms is difficult to establish. They vary in size, in the height of the spire, and, owing largely to warping, in the outline of the outer lip. The type individual is one of the largest collected, the apical whorls are less elevated than in many, and the margin of the outer lip is broken, destroying the minutely elliptical outline of the aperture, which is characteristic of the species.

Probably the fossil pteropods have a much wider distribution than the literature indicates, for the shells are all small and easily overlooked.

<sup>3</sup> GARDNER, JULIA A., *New species of mollusks from the Eocene of Texas*. Journ. Washington Acad. Sci., 17 (14): 362-383, 4 pls., 44 figs. 1927.

Among the related forms are *Limacina inflata* (d'Orbigny), 1835, a warm-water Recent species,

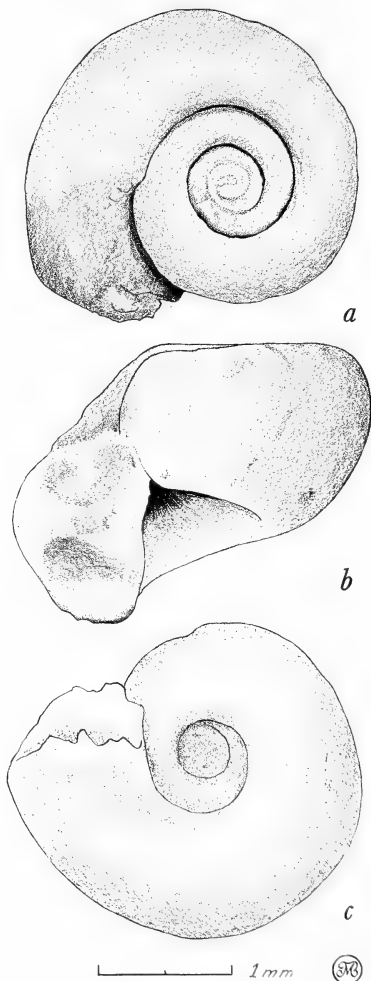

FIG. 2.—*Spiratella augustana* Gardner, n. sp.: a, Apical view of holotype; b, profile of holotype; c, umbilical view of holotype.

and *Limacina elevata* Collins,<sup>4</sup> described from the middle Miocene of Santa Rosa, Veracruz, Mexico.

Many of the Recent species, possibly the majority, are to be found in the plankton of the Arctic.

The distribution of *Spiratella augustana*, like that of other planktonic forms, is independent of the character of the bottom except as bottom conditions affect the preservation of the dead shell. The species is contained in glauconitic sandy clays, glauconitic sands, and blocky siliceous clays. Except for a few interruptions by oyster reefs, *Spiratella augustana* is disseminated through almost the entire upper 57 feet of Tallahatta exposed along Little Stave Creek, at Lisbon Bluff and in a few nearby localities. The species seems also to lightly overstep the Tallahatta-Lisbon contact and may be recorded by a few closely related if not identical individuals in the lower 10 feet of the Lisbon formation.

DISTRIBUTION: Tallahatta formation. Little Stave Creek, 4½ miles north of Jackson, Clarke County, Alabama; U.S.G.S. station 14785 b-c, from 10 to 20 feet below the *Ostrea johnsoni* bed;

<sup>4</sup> COLLINS, ROBERT LEE, *A monograph of the American Tertiary pteropod mollusks*. Johns Hopkins Univ. Stud. Geol. no. 11: 137-234, pls. 7-14. 1934.

PALEONTOLOGY.—*Nucula austinclarki*, *n. sp.*, a concentrically sculptured *Nucula* from the Lisbon formation of Alabama.<sup>1</sup> F. STEARNS MACNEIL, U. S. Geological Survey.

Strong concentric sculpture, although not unknown, is so unusual among the Nuculidae that the question arises as to whether the few species that possess it are closely related and constitute a natural generic or subgeneric group. The ribs on different species are so dissimilar in cross section, however, that this close relationship seems doubtful. In some species the ribs are inclined steps with the high, sharp edge on the dorsal side, as in *Nucula austinclarki*, here described. In other species the high sharp edge is on the ventral side. Still other species have more symmetrical ribs with either sharp or rounded crests.

<sup>1</sup> Published by permission of the Director, U. S. Geological Survey.

U.S.G.S. station 14431, 40 feet below the top of the Tallahatta formation; between the *Ostrea johnsoni* bed and the Tallahatta-Lisbon contact, U.S.G.S. stations 14785 f-h, 17910, 17911, 17913, 17907, 17909, 17912, 17926, 17927, 17916 a-b, 17919 a: Lisbon Bluff, Lisbon Landing, Alabama River, Monroe County, Ala.; U.S.G.S. station 13430, bluish-black clay at base of section; U.S.G.S. stations 13440 and 13443, indurated layer about 8 feet below the Tallahatta-Lisbon contact; and U.S.G.S. station 13442, dense blue-gray clay with lucinoid molds directly below the fucoidal layer and not more than 5 feet below the Tallahatta-Lisbon contact; U.S.G.S. station 14799, 3.8 miles east of Silas on Bladen Springs road, Choctaw County, Ala.

Within the area, *Spiratella augustana* is most common at the stations on Little Stave Creek between the *Ostrea johnsoni* bed and a level a little below the Tallahatta-Lisbon contact. It is present, however, up to the very contact, to the blocky siliceous clays of the contact specimen itself.

Closely related though possibly not specifically identical individuals have been recovered from levels not more than 10 feet above the contact at U.S.G.S. stations 17917, 17923, and 17924.

According to Schenck,<sup>2</sup> the primary division of the Nuculidae should be on the presence or absence of denticulations of the ventral margin. All the species with concentric sculpture except one have denticulations on the ventral margins, and all these are referred to *Nucula* s.s. on the basis of shape, teeth, and ligament. Only one form, the genus *Nuculoma* of Cossmann, with concentric sculpture and no marginal denticulations is known. *Nuculoma*, which is known only from the Jurassic, appears from the figures to have concentric ribs that are gently inclined on the dorsal side and sharp on the ventral side, just the reverse of the condition in the species here described.

<sup>2</sup> SCHENCK, HUBERT G., Bull. Mus. Royal Hist. Nat. Belgique 10 (20): 18. 1934.

Three species of *Nucula* with concentric sculpture were listed by Schenck. They are: *N. haesendonckii* Nyst and Westendorp, from the Anversian (upper Miocene) of Holland, a species with *Inoceramus*-like concentric ribs, *N. compressa* Philippi, from the Chattian (upper Oligocene) of Belgium, described as having "distinct concentric undulations," and *N. duchastelii* Nyst, from the Rupelian (middle Oligocene) of Belgium, a species with strong but very irregular concentric ridges that converge and diverge across the shell.

In addition to these Oligocene and Miocene species, two other Miocene and a Recent species have been described. *Nucula* (*Nucula*) *njalindungensis* Martin, from the lower Miocene of Java and Borneo, like *N. duchastelii*, has concentric lines that freely converge and diverge. *Nucula prunicola*, Dall, from the middle Miocene of Maryland has concentric ribs that are highest and sharp at the dorsal edge and gently sloping on the ventral side. They are thus of the same type as those of the new species but are developed at the anterior end of the shell only. The chondrophore of *N. prunicola* is also much narrower than that of the species here described. *Nucula exigua* Sowerby is living from California to southern Mexico. It has concentric lirations that are more or less symmetrical and are highest along a central crest.

From the Eocene three species with concentric sculpture have been described. The new species is also of Eocene age. Two of these are from the Calcaire grossier of France, *N. capillacea* Deshayes and *N. minor* Deshayes. The third was described from the London clay of England as *N.*

*regnorum* Wrigley. All these species are small, the largest specimen of *N. regnorum* measuring 8.0 mm, and both of Deshayes's species being less than 5.0 mm in length.

A description of the new Eocene species follows:

Genus *Nucula* Lamarck, 1799

Type: *Arca nucleus* Linnaeus.

The species here described is characterized by its very unusual concentric sculpture. The shell is large for the genus, but on the basis of its shape, teeth, ligament, and marginal denticulations it appears to be a typical *Nucula*.

*Nucula austinclarki* MacNeil, n. sp.

Figs. 1, 2

Shell large and medium inflated, subovate; anterior dorsal margin gently curved; anterior extremity blunt but straighter along the dorsal margin; lunular area substrate; posterior margin gently curved; posterior extremity subangulate; escutcheon area truncate, with the posterior ridge curving gently in a direction opposite to the curve of the posterior margin; outer surface sculptured by strong concentric ribs that are inclined and low on the ventral side, but with a sharp, usually undercut edge on the dorsal side; most of the ribs continuous around the shell but an occasional one is partly covered or overlapped by the next younger one; ribs with faint radial lines at some points; ventral margin with well developed denticulations; teeth on the anterior side regular and nesting within each other, about 22 in number, posterior teeth less regular, not forming a uniformly chevroned series, about 10 in number; interior smooth, muscle scars impressed, pallial line strong and entire.



FIGS. 1, 2.—*Nucula austinclarki* MacNeil, n. sp., Middle Eocene, Lisbon formation, Clarke County, Ala.; holotype (U.S.N.M. no. 560585): 1, Exterior; 2, interior.

Holotype (a left valve) (U.S.N.M. no. 560585) measures: Height 22 mm, length 27 mm, diameter of single valve 7.8 mm.

Type locality and only known occurrence: A gully in the west center of sec. 10, T. 9 N., R. 4 E., Clarke County, Ala. The gully lies on the south side of the county road.

This species is closely related to *Nucula magnifica* Conrad, a species described from the Gosport sand in the upper part of the Claiborne group of Alabama, and also present in the Lisbon formation of Alabama and the equivalent portion of the McBean formation of eastern Georgia and South Carolina in the middle part of the Claiborne group. In shape, size, and dentition the two species are nearly identical. *Nucula magnifica* has a smooth surface, but occasional specimens show a slight tendency for the de-

velopment of concentric markings similar to those of *N. austinclarki* at a point or two along the posterior ridge.

*Nucula austinclarki* is from the Lisbon formation, the middle part of the Claiborne group in Alabama. Its association with *Ostrea sellaeformis* indicates that it is from the middle or upper part of the Lisbon and not from the lowest part, which carries *Ostrea lisbonensis*, the apparent forerunner of *O. sellaeformis*. From the general field relations it appears to occur in the lower part of the range of *Ostrea sellaeformis*. *Nucula magnifica* is apparently a younger species than *N. austinclarki*, being known from the upper part of the range of *Ostrea sellaeformis* and from the Gosport sand, which is stratigraphically higher than the upper limit of the range of *Ostrea sellaeformis*.

MALACOLOGICAL.—*New stenothyrid gastropods from the Philippines (Rissoidea).*<sup>1</sup>

R. TUCKER ABBOTT, U. S. National Museum. (Communicated by H. A. Rehder.)

During a survey of fresh-water mollusks in 1945 on the Island of Leyte, Republic of the Philippines, ecological and morphological notes were made on living specimens of a species of *Stenothyra* Benson, 1856, which has subsequently proved to be undescribed. An undescribed subspecies from Mindoro Island of this polytypic species was found in the U. S. National Museum. It was collected in the 1880's by J. F. Quadras and bore the manuscript name of "philippina Moellendorff." These two gastropods are named in honor of Austin H. Clark, retiring curator of echinoderms, United States National Museum, who has given me great encouragement and help.

*Stenothyra austini*, n. sp.

Figs. 1, 3-7

*Description.*—Shell small, about 3.0 mm in length, ovoid, relatively thick-shelled, compressed ventrally, with a small circular aperture, and with unevenly developed whorls. Spire blunt and somewhat rounded. Nuclear whorls  $1\frac{1}{2}$  in number, transparent. Postnuclear whorls 3 to 4 in number, increasing irregularly in size (so that the

ventral face is flattened) until the last whorl, when they then decrease in size and form the relatively small, circular aperture. Periphery of early whorls well-rounded; last whorl moderately rounded. Suture finely and sharply impressed. Base of shell set at  $45^\circ$  to the axis of the shell, slightly convex, and thickened slightly in the area near the very small umbilicus. Aperture almost circular, with a slightly thickened continuous peristome. Behind the lip, on the exterior of the body whorl, there is a slightly thickened, smooth varix. Axial sculpture absent. Spiral sculpture consists of 10 to 15 rows of microscopic pits on the upper two-thirds of the whorl. The pits may be round, squarish or oblong. Umbilicus reduced to a minute chink. Color of shell from yellowish tan to light brown. In living specimens, the shell is translucent and the pits appear as tiny bubbles embedded in the shell. Periostracum thin, light tan. In living specimens, it covers the small pits. It is often covered with a blackish film of organic detritus. Operculum almost circular, chitinous, paucispiral, with the nucleus near the center. There are two raised, oblong lamellae of chitin reinforcing the surface of attachment. The anterior, inner edge is reinforced by a low, curved ridge (see Fig. 4). In adults, the operculum is often slightly larger than the aperture and incapable of being withdrawn into the shell.

<sup>1</sup> Published by permission of the Secretary of the Smithsonian Institution. Received October 6, 1950.



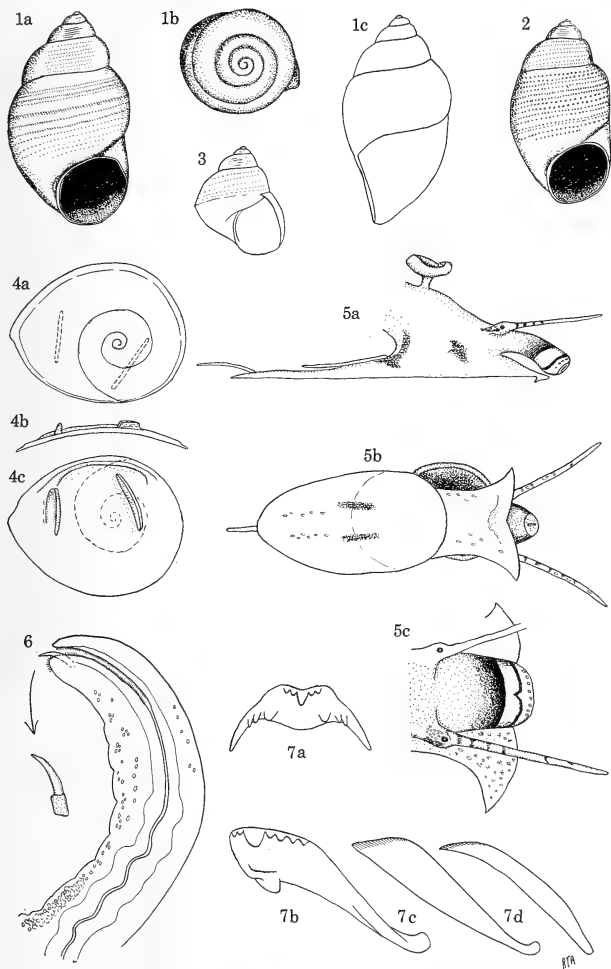

FIGS. 1, 3-7.—*Stenothyra austini austini*: 1, Holotype shell ( $\times 10$ ) (a, apertural view; b, apical view; c, side view); 3, immature shell; 4, operculum (a, outer view; b, side view; c, inner view); 5, living animal (a, lateral view; b, ventral view; c, dorsal view of head region); 6, male genitalia (verge); 7, radula (a, rachidian; b, lateral; c, inner marginal; d, outer marginal).

FIG. 2.—*Stenothyra austini clarki*, holotype shell ( $\times 10$ ).

		Measurements of shell (mm)		
Length	Width	Aperture	Whorls	
4.0	2.2	1.2 by 1.2	5.3 (holotype)	
4.0	2.1	1.3 by 1.3	5.5 (paratypes)	
3.5	2.1	1.0 by 1.1	5.0 (U.S.N.M. No. 603670)	
3.3	1.8	0.9 by 1.0	5.0 U.S.N.M.	
2.8	1.7	0.8 by 0.9	4.9 U.S.N.M.	
2.1	1.6	1.1 by 1.0	4.0 U.S.N.M. (young)	

Measurements of 97 adult paratypes from San Joaquin Estuary, eastern Leyte Island (U.S. N.M. no. 603671) were made to a tenth of a millimeter and grouped in the following classes:

Length (mm)	Number of specimens
2.6-2.9	13
3.0-3.3	47
3.4-3.7	35
3.8-4.2	2

*Animal*.—Small and capable of being completely retracted into the shell. Foot relatively long, flat, with the anterior corners produced laterally, and with a transverse division across the sole about halfway back and at a point coinciding with the anterior edge of the operculum. Anterior edge of foot with a deep, narrow, transverse mucus slit which bears minute cilia. A bulbous pedal gland may be seen at the anterior end from a ventral view. At the posterior end and dorsal side of the foot there is a long, slender, fleshy rod. Proboscis large, swollen in the middle, with two circular color bars of black-brown near the anterior end. The posterior bar fades posteriorly into an area of dark reddish brown. Between the bars the flesh is bright, straw-yellow. Tentacles long, slender, flecked with bars of black and an occasional internal granular clump of yellow. Area about eye dark gray, posteriorly with a heavy concentration of embedded light-straw granules. Mantle light gray with heavy mottlings of black. Vergé located on the midline of the "back" of the animal. It is in the form of a coiled, single prong. The distal end bears a minute calcareous spine. The radula is taenioglossate (see Fig. 7).

The typical subspecies *austini austini* is characterized by the weak pits in the shell and the irregular spacing of the spiral rows of pits.

*Type locality*.—Bridge at Kaboynan, near the mouth of the north fork of the Guinarona River, Leyte Island, Republic of the Philippines. R. T. Abbott, legit, June 18, 1945.

*Types*.—Holotype, U.S.N.M. no. 603669. Paratypes from the type locality, U.S.N.M. no. 603670, and in the Museum of Comparative Zoology, Cambridge, Mass. (the latter collected by M. S. Ferguson). Paratypes also from San

Joaquin Estuary, eastern Leyte Island, R. T. Abbott, legit, June 29, 1945 (U.S.N.M. no. 603671); Abuyog, eastern Leyte Island, R. T. Abbott, legit, August 14, 1945 (U.S.N.M. no. 603672).

*Ecology and habits*.—These mollusks are very active but shy creatures and were collected in three estuarine localities on Leyte Island. At the type locality they were found in 6-inch-deep, stagnant, brackish-water pools under the shade of floating palm fronds. The bottom was black ooze. *Syncera* and *Neritina ziczac* Linnaeus were found in the same neighborhood. At San Joaquin they were found under similar conditions where the water temperature was 81° F. and the pH 7.6. Several species of *Syncera*, a *Cerithidea*, and *Clenchiella victoriae* Abbott, 1948, were collected with them. These *Stenothyra* are rapid crawlers. At the slightest disturbance they snap back into their shells with remarkable speed.

*Remarks*.—The only other described species of *Stenothyra* in the Philippines that possesses spiral rows of pits is *S. quadrasi* Moellendorff, 1895, which, however, is a much larger shell (7 mm in length), much thicker, with a very thick, flattened, and spirally lirated base, and with distinctly angled early whorls. *S. austini* apparently has a wide range throughout the Philippines but appears to be broken up into geographical, insular races or subspecies. We have a single specimen from Bacoor Bay, Luzon (U.S.N.M. no. 603674), but we hesitate to describe it as a new race until additional material is at hand.

#### *Stenothyra austini clarki*, n. subsp.

Fig. 2

Shell similar to *S. austini austini* but differing in having deeper and larger pits and in having the spiral rows evenly spaced. In *austini* there are often three or four rows missing. The shells of our specimens of *S. austini clarki* are reddish brown in color, but this may be due to ecological conditions. Holotype: Length, 3.4; width, 1.9 mm.

*Type locality*.—The holotype, U.S.N.M. no. 603673, is from Manglares, between Bacoy and Calapan, Mindoro Island, Republic of the Philippines. J. F. Quadras, legit, circa 1880. Two paratypes from the same locality, U.S.N.M. no. 303387, are probably from the same collector.

The difference in shape between these subspecies, as seen in Figs. 1*a* and 2, is not specifically significant. Some specimens of *austini* are similar to those of *clarki* in shape and size.

**MALACOLOGY.**—*Two new Western Atlantic species of pulmonate mollusks of the genus Detracia and two old ones (family Ellobiidae).*<sup>1</sup> J. P. E. MORRISON, U. S. National Museum.

The molluscan genus *Detracia* Gray, 1840, is represented in the Western Atlantic region by four known species. They divide evenly: Two have been previously named; two are new. Two are continental; two are island species in their geographic distribution.

I wish to thank particularly Dr. H. A. Pilsbry and the authorities of the Academy of Natural Sciences of Philadelphia for the opportunity to borrow freely and study all specimens of this genus in the Academy collections. Without such study of many specimens additional to those in the United States National Museum collections, the zoogeographic picture here presented could not have been so complete.

***Detracia floridana* (Pfeiffer), 1856**

Figs. 4, 7

This manuscript name of Shuttleworth was first validly published in Pfeiffer's *Monograph auriculaceorum*, p. 35, no. 35, 1856. W. G. Binney, the first subsequent American author to study the group, unfortunately selected the wrong specimen for figuring in 1859 in his *Terrestrial mollusks of the United States* 4: pl. 75, fig. 30, from the mixture of species brought back from the Florida Keys by Bartlett for his father, Amos Binney. This figure represents the smallest (dwarf) form of *Melampus bidentatus* Say we know from the Florida Keys, instead of *floridana*.

Because every succeeding illustrator of the group has copied this earliest figure of Binney, this species, the only one of the family confined to United States shores, has, up to the present time, almost a century later, not yet been figured! The presence in the literature of an incorrect figure makes the generic confusion that has so long surrounded this species easy to understand.

*D. floridana* may be easily distinguished by its small size and, even in the youngest individuals seen (1.5 mm long), by the more regularly biconic shape. The aperture is markedly constricted be-

low (anteriorly) by the columellar lamella. There is a single palatal lamella, which is horizontal and approximately equal in height to the columellar. Between these two the palatal wall is well rounded and usually heavily calloused. The parietal wall is usually furnished with about 10 subequal, low lamellae, as in most species of the genus *Melampus*. These minute lamellae are sometimes present posteriorly along almost the full length of the parietal wall. In many young specimens their inner extensions are visible through the translucent penultimate whorl.

The specimens figured (U.S.N.M. no. 473892) are part of a lot collected on August 26, 1938, from the salt marsh at Chesapeake Beach, Calvert County, Md.

The adult (Fig. 7) has 10<sup>2</sup> whorls and measures: Height 7.9 mm; diameter 4.8 mm; aperture height 5.8 mm; aperture diameter 2.2 mm. The younger individual (Fig. 4) has 11 whorls and measures: Height 6.6 mm; diameter 3.6 mm; aperture height 4.5 mm; aperture diameter 1.9 mm.

*D. floridana* is entirely continental in geographic distribution. It is recorded only from Delaware and Chesapeake Bays, east and west Florida, and the Gulf coast of Alabama, Mississippi, and Louisiana. The present lack of locality records from the Carolinas and Georgia is probably due to the fact that no collecting has been done in the transitional estuarine (freshwater-brackish-salt) marshes of those coastal areas. In the Chesapeake Bay area, where it is perhaps now best known, it seems to prefer or tolerate a lower degree of salinity in the salt-marsh habitats than does its neighbor and relative *Melampus bidentatus lineatus* Say. Under estuarine conditions this species is sometimes astoundingly abundant. With an observed concentration of more than one individual per square inch, it was estimated on June 28, 1950, that in just 1 square mile of the estuary marshes of the Pocomoke River (Accomack County, Va.) there were twice as many individuals of *Detracia floridana* as there are human beings in the entire world. In other words, more than 4 billion of these small snails inhabit this one particular square mile!

<sup>1</sup> Published by permission of the Secretary of the Smithsonian Institution. Received October 6, 1950.

<sup>2</sup> Apex eroded. Number of whorls indistinct.

*Detracia clarki*, n. sp.

Figs. 2, 6

Shell large (for the genus), obovate, smoothish, of 10-12 whorls, with moderate spire somewhat variable in height but usually about one-third the height of the aperture. Body whorl tending to be subcylindrical, smoothly sculptured with minute growth lines only, except for a few incised spiral lines above the shoulder and near the base. Aperture sublinear, conspicuously obstructed by two heavy, upturned (posteriorly dished) axial lamellae, which are continuous from the plane of the aperture to about three-fourths of a whorl within. The columellar, the most prominent of the two, usually extends more than half-way across the aperture to the parietal wall. The outer lip (parietal wall) bears a variable number (a few) of well-spaced lamellae essentially alternating with the axials basally (anteriorly). In addition, the aperture of adults shows a greater number of low parietal lamellae interpolated on an internal ridge or varix along the parietal wall, behind which ridge the parietal lamellae are much reduced in height and prominence.

The holotype U.S.N.M. no. 594588 (Fig. 6), has 11 whorls and measures: Height 12.5 mm; diameter 6.7 mm; aperture height 9.8 mm; aperture diameter 3.2 mm. It and 14 paratypes, U.S.N.M. no. 36062, were collected at Key West, Fla., by Henry Hemphill previous to 1884. It is not absolutely certain that these specimens were taken on Key West, as the older custom was to give general localities only. They may have come from either Stock Island or Boca Chica Key nearby, where it seems evident the species is still living. The younger specimen (Fig. 2) (U.S.N.M. no. 594589) comes from Stock Island, Fla. It has 10 whorls and measures: Height 6.5 mm; diameter 4.0 mm; aperture height 4.7 mm; aperture diameter 2.3 mm.

The geographic distribution as recorded for the 532 specimens at hand includes the Bahamas (?), the Florida Keys, and Cuba, as follows: BAHAMAS: 1 specimen (U.S.N.M. no. 594592) from Great Abaco Island, perhaps drifted to this locality. FLORIDA: "Miami" (S. N. Rhoads, 1899); a key near Chokoloskee; Virginia Key (Biscayne Bay); Pumpkin Key (Card Sound); Middle Key (Barnes Sound); Tavenier Key and Key Largo; from Indian, Lower Matecumbe, Bahia Honda, New Found Harbor, Windley's, Torch, Geiger's, Sugar Loaf, Big Pine, and Boca Chica Keys; Stock

Island; and Key West. An old record of "St. Augustine" is doubtful, except as a possible drift specimen. CUBA: Recorded at present from only two widely separate localities: Punta Cajon, Pinar del Río (U.S.N.M. no. 492571), and Cayo Perro, Cardenas Bay (U.S.N.M. no. 594590). In other words, *Detracia clarki* is at present known only from a restricted area in the Western Atlantic along the Straits of Florida.

Of the size and general shape of *Melampus bidentatus* Say, with which it occurs, and *Pira monile* Bruguière, *D. clarki* is readily distinguished on apertural characteristics. The extra-heavy columellar lamella, higher than the palatal, and by far the most prominent of the aperture, reaching nearly to the parietal wall in some individuals, is turned upward within, to form a cup-shape structure whose rim approaches a parallel to the columellar axis. This extreme constriction of the basal part of the aperture by the columellar lamella will separate it from *Melampus bidentatus*, while the absence of cuticular setae or the remaining scar-pits of the same on the spire will easily separate it from *Pira monile*. *D. clarki* is distinct from all others by the conspicuously posteriorly dished or upcurved direction of the columellar lamella. It is twice the size, when adult, of any other known member of the genus *Detracia*.

This species is named in honor of Austin H. Clark, retiring curator of echinoderms of the United States National Museum, in some small recognition of his outstanding faculty for inspiring others in the solution of problems of the zoogeography of invertebrate animals of all types from every corner of the world.

*Detracia bullaoides* (Montagu), 1808

Figs. 1, 5

This the genotype species was first described from shells recovered from ballast discarded along the coast of England. For many years, however, it has been well known as a characteristic species of the West Indies. It is figured here to complete the picture of West Atlantic forms, so that future students will not have to search elsewhere for comparable illustrations.

*D. bullaoides* is easily distinguished by the more elongate shape of most adults, as well as by the heavily buttressed palatal lamella. The few low parietal lamellae are present only on the basal (anterior) portion of the parietal or outer

wall of the aperture. In most adult shells the aperture is posteriorly exceedingly narrow and linear.

The adult specimen, U.S.N.M. no. 466289 (Fig. 5), has 12 whorls and measures: Height 9.5 mm; diameter 4.3 mm; aperture height 5.6 mm; aperture diameter 2.2 mm. It is one of many specimens collected on the edge of the mangrove swamp on Shell Key, off St. Petersburg, Fla., April 24, 1936. The younger specimen (Fig. 1) has 10 whorls and measures: Height 6.2 mm; diameter 3.2 mm; aperture height 4.3 mm; aperture diameter 2.0 mm. It comes from the same lot.

*D. bullaoides* is apparently primarily Greater Antillean in its geographic range. The United States National Museum collections include specimens from the Bermudas; from Fernandina to Key West and to Cedar Keys, Fla.; the Bahamas; Cuba; Jamaica; and Hispaniola. There are also records of this species in the collections of the Academy of Natural Sciences of Philadelphia from St. Croix, Virgin Islands; and Tampico, Mexico.

*Detracia parana*, n. sp.

Fig. 3

Shell small, obovate-biconic, smooth, of about 10 whorls. Spire moderate, equal to about one-fourth the total length of the shell. Body whorl well rounded, smoothly sculptured with minute growth lines only, with the very low, rounded shoulder about midway of the shell height. Aperture moderately narrow, constricted by a prominent horizontal or downwardly (anteriorly) directed columellar lamella, which extends forward to be continuous with the base of the outer lip. The palatal wall is furnished with a single low horizontal lamella a little below the middle of the aperture. This is inconspicuous and in specimens seen extends only about one-fourth of the way to the parietal wall. The parietal wall is not furnished with lamellae but appears smooth.

The holotype, U.S.N.M. no. 594591 (Fig. 3), and three paratypes, U.S.N.M. no. 32090, were collected from the Amazon River at Pará, Brazil, by J. B. Steere, previous to 1885, when they were catalogued at the United States National



Figs. 1, 5.—*Detracia bullaoides* (Montagu), young and adult, U.S.N.M. no. 466289, from margin of mangroves on Shell Key, off St. Petersburg, Fla., April 24, 1936, J. P. E. Morrison.

Fig. 2.—*Detracia clarki*, n. sp., young paratype, U.S.N.M. No. 594589, from Stock Island, Fla., P. Bartsch.

Fig. 3.—*Detracia parana*, n. sp., holotype, U.S.N.M. no. 594591, from the Amazon River, Pará, Brazil. J. B. Steere.

Figs. 4, 7.—*Detracia floridana* (Pfeiffer), young and adult, U.S.N.M. no. 473802, around grass roots in salt marsh at Chesapeake Beach, Md., August 26, 1938, J. P. E. Morrison.

Fig. 6.—*Detracia clarki*, n. sp., holotype, U.S.N.M. no. 594588, Key West, Fla., H. Hemphill.

Museum. The holotype has  $10^3$  whorls and measures: Height 6.8 mm; diameter 3.9 mm; aperture height 5.2 mm; aperture diameter 2.0 mm.

This new species is almost exactly like the North American continental species *floridana* in general appearance but differs considerably in the detail of lamination of the aperture. It lacks any marked callosity of the aperture above the columellar lamella. The columellar wall below

<sup>3</sup> Apex eroded. Number of whorls indistinct.

**MALACOLOGY.**—*A new species of glycymerid from the Philippines.*<sup>1</sup> DAVID NICOL, U. S. National Museum.

This is a report on a new species of glycymerid collected by the U. S. Fish Commission steamer *Albatross* on the Philippine expedition of the years 1907 to 1910. It is my intention to give a complete account of the Glycymeridae of this collection at a later date.

Genus *Axinactis* Möreb, 1861

Genotype (subsequent designation by Hertlein and Strong, 1943, p. 153): *Pectunculus inaequalis* G. B. Sowerby, 1833; Recent; Pacific coast of Panama and Nicaragua.

*Axinactis* is the earliest generic name available for the raised-ribbed species of glycymerids, which are nearly always confined to warm waters. This large group of glycymerids has had an independent history as far back as Oligocene time and is certainly not closely related to *Glycymeris glycymeris* (Linné).

Subgenus *Melaxinaea* Iredale, 1930

Genotype (original designation): *Melaxinaea labyrinthica* Iredale, 1930; Recent; Albany Passage, Queensland, 9–12 fathoms.

*Axinactis* (*Melaxinaea*) *clarki* Nicol, n. sp.

Figs. 1–3

*Description.*—Valves compressed, ratio of convexity to height about 0.50; dorsal margin long and straight giving shell an eared appearance, anterior, ventral, and posterior margins rounded; light reddish-brown spots on ribs, interior usually colorless, occasionally reddish-brown spots on

(anterior to) the palatal lamella is rather flat, not markedly arched and calloused in this region as it is in *floridana*. Though the number of specimens of *parana* at hand is very small, the observed differences, together with the observed similarities, of a molluscan species purporting to come from an absolutely comparable estuarine habitat on South American West Atlantic shores lead me to advance *Detracia parana* as a species that has developed completely parallel to its close relative *D. floridana* of North America.

margins; beaks contiguous, orthogyrate; umbos flat and inconspicuous, located approximately at center of dorsal margin; ligament narrow and elongate, made up of four or five chevron-shaped parts; hinge teeth 23 to 28 in number, averaging 25, arranged in a broad arch on a large flat hinge plate, teeth tending to disappear at center of hinge plate in mature specimens; crenulations on interior ventral border well-marked, usually pointed at end, though sometimes rounded, depressed at center, 15 to 21 in number, averaging 17, not divided as is common in some species of *Melaxinaea*; adductor muscle scars approximately equal in size; radial ribs raised but not prominent, 24 to 28 in number, averaging 26, ribs on central part of shell flat-topped, often with a shallow central groove, occasionally with two or three small ridges; at either end of shell ribs split into fine, slightly nodulose, crooked, riblets, occasionally a small radial rib added in interspaces, the latter almost as wide as ribs at ventral margin; ribs and interspaces crossed by fine, closely spaced, concentric striae which are more prominent on interspaces.

Measurements in mm

Specimen	Length	Height	Convexity of both valves
Holotype 236879	34.6	34.0	18.1
Paratype 293039	20.6	20.0	10.0
Paratype 293039a	17.0	16.8	8.0
Paratype 293039b	17.0	16.6	8.4
Paratype 293039c	16.4	16.4	8.6
Paratype 293039d	15.9	15.8	7.8
Paratype 293039e	15.0	14.4	7.8
Paratype 293039f	15.4	15.4	7.6
Paratype 293039g	11.6	12.3	6.4

*Type specimens.*—The holotype and paratypes are in the collection of the U. S. National Museum, Division of Mollusks: Holotype no. 236879, paratypes nos. 293039 and 296058. Thirty-nine

<sup>1</sup> Published by permission of the Secretary of the Smithsonian Institution. Received October 6, 1950.

specimens of the species were studied, but only the holotype is a mature shell. Many of the remainder, however, show the adult rib character and outline of the valves.

*Locality data.*—Station 5192, Jilantangan Island between Bantayán Island and the north-west end of Cebu (E., N. 13°W., 3 miles 11°09' 15"N., 123°50'E.), 32 fathoms, green sand. Station 5277, Malavatuan Island, Lubang Islands northwest of Mindoro (N., S. 56°E., 8 miles 13°56'55"N., 120°13'45"E.), 80 fathoms, fine sand.

*Comparisons.*—*Axinactis (Melaxinaea) clarki* most nearly resembles *Pectunculus maskatensis* Melvill, 1897, from Maskat, on the Gulf of Oman. The latter species has larger and more prominent ribs and greater length in comparison to its height. *Pectunculus vitreus* Lamarck has a more angular arrangement of teeth and beaded or granulose ribs. *Pectunculus nova-guineensis* Angas has nodulose ribs and a shorter dorsal margin than *Axinactis (Melaxinaea) clarki*. *Melaxinaea labyrinthica* Iredale, the genotype of *Melaxinaea*, is from Albany Passage, Queensland. It has nodulose ribs that are more numerous, narrower, and more closely spaced on the adult shells. *Melaxinaea litoralis* Iredale from Townsville, Queensland, has a more rounded outline and has finer and more numerous radial ribs. *Glycymeris planiuscula* Chapman and Singleton from the Pliocene of Australia has more closely spaced rounded ribs. *Glycymeris uziniensis* Cox from the Pliocene of Zanzibar has tuberculated ribs and a rounded or subtrigonal outline.

*Glycymeris dautzenbergi* Prashad (1932, pp. 65, 66) is a homonym of *Pectunculus dautzenbergi* Gregorio (1892, p. 109). *Glycymeris dautzenbergi* Prashad is herewith renamed *Glycymeris prashadi*. This species from the Arafura Sea has nodulose ribs on all of the shell and a shorter dorsal margin than *Axinactis (Melaxinaea) clarki*.

## REFERENCES

- ANGAS, G. F. *Descriptions of ten new species of Axinaea and Pectunculus in the collections of Mr. Sylvanus Hanley and the late T. L. Taylor*. Proc. Zool. Soc. London for 1879 (3): 417-420, pl. 35. 1879.
- CHAPMAN, F., and SINGLETON, F. A. *A revision of the Cenozoic species of Glycymeris in southern Australia*. Proc. Roy. Soc. Victoria (n.s.) **37** (pt. 1, art. 2): 18-60, 4 pls. 1925.
- COX, L. R. *Neogene and Quaternary Mollusca from the Zanzibar Protectorate*. Extracted from the report on the Paleontology of the Zanzibar Protectorate, published by the Government of Zanzibar, pp. 13-180, pls. 3-19. 1927.
- GREGORIO, ANTONIO DE MARCH. *Sul genere Pectunculus precipuamente sulle specie viventi mediterranee e fossili nel Terziario superiore*. II Naturalista Siciliano **11** (5): 106-114. 1892.
- HERTLEIN, LEO G., and STRONG, A. M. *Mollusks from the west coast of Mexico and Central America, pt. 2*. Zoologica **28** (3): 149-168, 1 pl. 1943.
- IREDALE, TOM. *Queensland molluscan notes, no. 2*. Mem. Queensland Mus. **10** (1): 73-88, pl. 9. 1930.
- . *Australian molluscan notes, no. 1*. Rec. Australian Mus. **18** (4): 201-235, pls. 22-25. 1931.
- . *Mollusca. In Sci. Rep. Great Barrier Reef Exped. 1928-29*, **5** (no. 6, pt. 1): 209-425, 7 pls. British Museum, 1939.
- LAMARCK, J. B. P. A. DE. *Histoire naturelle des animaux sans vertèbres...* **6** (1): 343 pp. 1819.
- MELVILL, JAMES COSMO. *Descriptions of thirty-four species of marine Mollusca from the Arabian Sea, Persian Gulf, and Gulf of Oman*. Mem. and Proc. Manchester Lit. and Philos. Soc. **41** (7): 25 pp., pls. 6, 7. 1897.
- MÖRCH, O. A. L. *Beiträge zur Molluskenfauna Central-Amerika's*. Malakozool. Blätter **7**: 170-213. 1861.
- PRASHAD, B. *The Lamellibranchia of the Siboga Expedition, Systematic Part II, Pelecypoda (exclusive of the Pectinidae)*. Siboga Monogr. 53c: 353 pp., 9 pls., 1 map. 1932.



FIGS. 1-3.—*Axinactis (Melaxinaea) clarki*, n. sp.: 1, Exterior view of holotype, left valve, U.S.N.M. no. 236879; 2, exterior view of paratype (young specimen), left valve, U.S.N.M. no. 293039a; 3, interior view of holotype, left valve, U.S.N.M. no. 236879. All figures natural size.

MALACOLOGY.—*Two new Recent cone shells from the Western Atlantic (Conidae).*<sup>1</sup>

HARALD A. REHDER and R. TUCKER ABBOTT, U. S. National Museum.

Two species of the genus *Conus* were received by the United States National Museum a few years ago from two dredging expeditions off southeastern United States. It appears that both species are undescribed, and we take pleasure in naming them for Austin H. Clark, retiring curator of echinoderms, United States National Museum. The first of these species, collected by the U. S. Fish and Wildlife Service trawler *Pelican* in 1938, is strikingly different from any known Recent species in the Western Atlantic. The second, dredged off southern Florida by the *Anton Dohrn*, is somewhat like the well-known species *Conus stimpsoni* Dall.

***Conus clarki*, n. sp.**

Figs. 1-6

*Description*.—Shell 36 mm (1½ inches) in length, relatively heavy, broadly fusiform, strongly spirally sculptured, and chalk-white in color. Whorls 12, the last whorl with a beaded carina at the shoulder, rounded at the periphery, and concave toward the base. Spire extended, pointed, concave, and slightly more than one-third of the entire length of the shell. Angle of spire about 70°. Nuclear whorls 1½, glassy-smooth. Aperture oblique, long and narrow, with a deep, rounded sinus at the top. Outer lip sharp, thin, and weakly crenulated. The lip is sinuate with the middle portion being advanced, and the lower portion retracted enough to make the end of the siphonal canal considerably open. Spiral sculpture consists of 27 to 30 very strong, raised, squarish, and beaded cords. The topmost spiral cord bears the largest beads, which in previous whorls may be seen just above the impressed wavy sutural line. The surface of these beads is obliquely scratched by fine irregular lines. Top of the whorls slightly concave and with three to five unequal fine spiral threads. Axial sculpture consists of numerous fine, sharply raised, arched threads which cross the spiral threads on the tops of the whorls (anal fasciole). Color of shell chalk-white. In one paratype specimen there are very weak reddish squares of color between the beads on the

spiral cords. Periostracum thin, deciduous, light brown, and axially striate.

Animal (Figs. 1-5) typical of the genus *Conus*, with a rather long siphonal extension of the mantle, which is flecked with fine black striations. Side of foot suffused with gray along the lower border. Verges large, 7 mm in length, shaped like a meat cleaver, with a slender, curved point at the end. Verges has fused lamellations on its sides and base. Poison gland and radular sheath typical of the genus. About 30 harpoonlike teeth were found in the sheath. Tooth short with one small barb at the end, two on the side and one at the base (see Fig. 3).

## MEASUREMENTS (MM)

Length	Width	Number of Whorls
36.0	16.0	11.0 (holotype)
36.0	16.0	11.0 (paratype male)
34.4	15.5	10.8

*Types*.—The holotype is U.S.N.M. no. 485740; one paratype, U.S.N.M. no. 488465; and another paratype is in the Museum of Comparative Zoology.

*Type locality*.—50 miles south-southwest of Marsh Island, Iberia County, La. (lat. 28° 27.0'N.; long. 92° 14.0'W.). Dredged by the U. S. Fish and Wildlife Service trawler *Pelican*, station 94-1, November 13, 1938, in 29 fathoms.

*Range*.—Known only from the type locality.

*Remarks*.—There is no living species described from the Western Atlantic that approximates *C. clarki* in the characters of heavy, raised, square, spiral cords, rounded periphery, attenuated basal portion (giving it a turniplike shape) and the prominent sharp axial, striae between the spiral cords. It is nearest in characters to the middle Miocene fossil *Conus (Leptoconus) multiliratus* Böse, 1906, from Tuxtepec, Oaxaca, Mexico, and its subspecies *gaza* Johnson and Pilsbry, 1911, from the Dominican Republic, Jamaica, Panama, and Colombia. However, the Recent *C. clarki* is much more turnip-shaped, and its cords at the shoulder of the whorl are strongly beaded.

***Conus austini*, n. sp.**

Fig. 7

*Description*.—Shell 56 mm in length, heavy, spirally sculptured, and dull-white in color. Whorls 14, almost straight-sided, but very slightly

<sup>1</sup> Published by permission of the Secretary of the Smithsonian Institution. Received October 6, 1950.



concave toward the base. Shoulders of whorl slightly rounded in adults but carinate in younger specimens. Spire extended, pointed, slightly concave, and about one-quarter the entire length of the shell. Angle of spire about 80°. Nuclear whorls 1½, glassy-smooth. Next five whorls sculptured by a single, beaded carina, which in the succeeding whorls becomes smooth and located just above the suture. Aperture oblique, long and narrow, with a deep, rounded sinus at the top. Outer lip thin, sharp, and weakly crenulate. Spiral sculpture consisting of about 40 fairly well-developed, irregularly sized, rounded cords, which become more prominent basally. Three to five low, weak, spiral threads present on the top of the whorls, which are obliquely crossed by the arched growth

lines of the anal sinus. There is a tendency in some specimens to produce alternately small and large cords. Between the cords the axial sculpture consists of fine, distinct, raised striae. Periostracum moderately thick, when dry becoming axially striate and light brownish yellow in color. Animal and operculum unknown.

MEASUREMENTS (MM)

Length	Width	Number of Whorls
55.5	25.3	14 (holotype Tortugas)
43.1	22.0	13 (paratype, Tortugas)
51.0	25.5	13 (paratype, Antigua)

*Types*.—The holotype is U.S.N.M. no. 603017; a paratype from the same dredging haul, U.S.N.M. no. 421721; a third paratype, U.S.N.M. no.

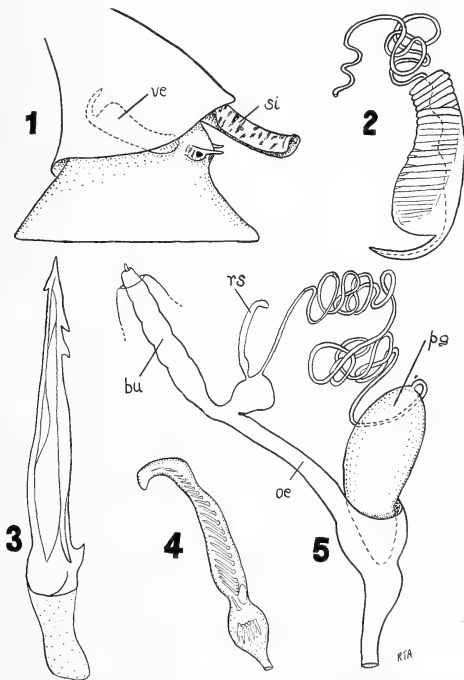

FIGS. 1-5.—*Conus clarki*, n. sp.: 1, Side view of male animal showing siphon (*si*) and position of verge (*ve*) (×3); 2, side view of verge and vas deferens (×10); 3, single tooth (×50); 4, radular sac showing arrangement of unused teeth (×25); 5, semidiagrammatic drawing of anterior alimentary system and poison apparatus, *bu*, buccal mass; *rs*, radular sac; *pg*, poison gland (×15).

603018, was dredged by the *Eolis, Jr.* by J. B. Henderson at the entrance of English Harbour, Antigua, Lesser Antilles, June 21, 1918.

*Type locality*.—Southeast of Loggerhead Key, Dry Tortugas, Florida. Dredged in 40 to 46 fathoms by W. L. Schmitt from the *Anton Dohrn*, June 21, 1932.

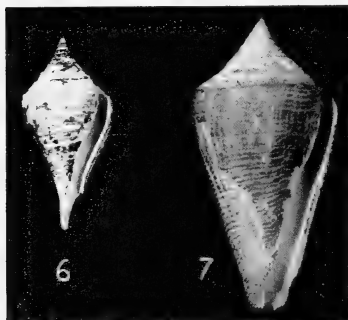

FIG. 6.—*Conus clarki*, n. sp., holotype. FIG. 7.—*Conus austini*, n. sp., holotype. (Both natural size.)

*Range*.—From Dry Tortugas, Fla., south to Antigua Island, Lesser Antilles.

*Remarks*.—This species is similar to *C. simpsoni* Dall but differs in being larger, having raised spiral cords instead of incised grooves, having numerous fine but distinct axial striae between the cords, and lacking any color markings. A young specimen of *C. austini* displays a number of axial wrinkles in the middle of the body whorl, a variable character common to some Miocene fossil species.

A similar species exists in the Gurabo formation, Dominican Republic (Miocene). Specimens of this fossil are in the U. S. National Museum, mixed in with lots labeled *C. planiliratus* Sowerby. It is apparently undescribed and differs from the Recent *C. austini* in having a slightly shorter spire, being half as high and rarely showing the tiny, angled keel on the shoulder of the whorls in the spire. Otherwise the shape and sculpture are extremely similar. *C. stenostoma* Sowerby, a Miocene fossil from the Dominican Republic, is also very close but has a very low spire and a sharper shoulder.

**MALACOLOGY.**—*A new scaphopod mollusk, Cadulus austinclarki, from the Gulf of California.*<sup>1</sup> WILLIAM K. EMERSON, Research Fellow, Allan Hancock Foundation. (Communicated by Harald A. Rehder.)

A recent visit to the United States National Museum provided me an opportunity to examine the Scaphopoda contained in the vast collection of the division of mollusks. A previously unrecognized species of *Cadulus* from the Gulf of California is here described.

I am indebted to Dr. Harald A. Rehder, curator of mollusks, for access to the facilities of the division, and to Frederick M. Bayer, assistant curator of marine invertebrates, for providing the camera-lucida drawing and the photograph. I take pleasure in dedicating this new species to Austin H. Clark, retiring curator of echinoderms in the United States National Museum.

Family SIPHONODENTALIIDAE

Genus *Cadulus* Philippi, 1844

♀ Genotype (by monotypy): *Dentalium ovulum* Philippi, 1844, Recent; Mediterranean Sea.

<sup>1</sup> Received October 6, 1950.

Subgenus **Platyschides** Henderson, 1920

Subgenotype (by original designation): *Cadulus grandis* Verrill, 1884; Recent, West Atlantic, north of Cape Hatteras.

Shell small to relatively large, moderately curved, greatest swelling between the middle and oral aperture, posterior portion and aperture slightly flattened dorsoventrally; surface without sculpture, smooth and polished; apex possessing four rather broad, but shallow notches; white.

This group differs from the subgenus *Poly-schides* in having the apical notches greatly reduced. The slits vary in size from small indentations, which appear as chipped-out portions of the margin, to minute features requiring considerable magnification in order to ascertain the structure. There are many Recent and Tertiary species.

***Cadulus (Platyschides) austinclarki*, n. sp.**

Figs. 1, 2

Shell is minute, fairly solid, vitreous, semi-transparent, very slender, moderately curved,



FIG. 1.—*Cadulus (Platyschides) austinclarki*, n. sp.: Holotype, approximately  $\times 20$ .

with the greatest diameter approximately two-fifths the distance from the oral aperture. The swelling is gradual and approaches uniformity, the equator not being conspicuously bulbular and the convex face forming a nearly uninterrupted arc. The outline of the concave side is very regular except for the area of slight equatorial swelling. The oral (anterior) aperture is constricted, slightly compressed dorsoventrally, but nearly circular in section; apertural margin is slightly oblique. Apex is not much attenuated, relatively large, circular in outline, with a rather oblique margin. The apical characters are minute but well defined. The apex has four shallow notches separated by as many lobes of nearly equal size. The slits are subtriangular in shape, very shallow, with concave pair slightly deeper; the lobes are subconical, with the greatest height of the lobe composed of the inner shell layer, the outer margin being beveled so as to provide a thin edge to the lobes (Fig. 2). The prominence of the lobes varies with individuals. In some specimens the vitreous shell is clouded by semiopaque circular zones producing alternate rings of more or less translucency.

*Measurements*.—Holotype, 4.4 mm long; diameter of apical orifice 0.35 mm; apertural diameter 0.55 mm. None of the paratypes measures more than 5 mm in length.

*Remarks*.—The extremely small size, narrowness, and distinctive apical characters serve to distinguish this species from all other Eastern Pacific forms. No living species thus far described from the Eastern Pacific approaches this species. The most similar living species appears to be *Cadulus (Platyschides) nitidus* Henderson (1920) from Mayagüez Harbor, Puerto Rico, in 25 fathoms. Though this West Atlantic species has similar apical features, it is longer and more attenuated and possesses even less equatorial swelling than *Cadulus austinclarki*. *Cadulus (Platyschides) parvus* Henderson (1920) from the Florida keys and off Barbados possesses nearly the same general outline but has a longer shell with more prominent apical features. *Cadulus (Platyschides) amiantus* Dall (1889) from off Bahia Honda, Cuba, is a larger more curved species with a greater equator. *Cadulus (Platyschides) miamiensis* Henderson (1920) from off Fowey Light, Fla., in 209 fathoms, is a much larger, more curved species with entirely different apical characters.

The National Museum records indicate that this new species is limited to the warm waters of the Panamic province. This is the first representative of the subgenus *Platyschides* reported from the Eastern Pacific region. Intensified collecting in this area will undoubtedly reveal the presence of other species belonging to this group.



FIG. 2.—*Cadulus (Platyschides) austinclarki*, n. sp.: Holotype, apical features greatly magnified, a  $\frac{3}{4}$ -oblique view with the concave face on the left side; line represents 0.5 mm.

*Type locality*.—Santa Inez Bay, Baja California (Gulf of California), west around Santa Inez Point, dredged in 6–12 feet of water in fine black sand; J. Hawkins, Jr., collector, March 30, 1940.

*Range*.—Santa María Bay, lat. 24°45'W, west coast of Baja California, Mexico (in Gulf of California: Santa Inez Bay, 27°N), to Panama City, lat. 8°50'N., and the Galápagos Islands, 1°N.

*Types*.—Holotype: U.S.N.M. no. 564527. Paratypes: 39 in number, U.S.N.M. no. 602347.

*Records* (latitudinal data approximate).—

*West Coast of Baja California, Mexico*

Santa María Bay, 24° 45' N., boat dredge, Bartsch (8).

Cape San Lucas, Bartsch (1).

*East Coast of Baja California, Mexico*

Fraile Bay, 23° 23' N., 10–30 feet, coarse, gray sand, Hawkins (5).

Pichilique Bay, 24° 13'N., Bartsch (18); 24° 13'N., 20–30 feet, Hawkins (2).

La Paz Bay, 24° 15'N., all Hawkins: Between La Paz and El Mogote, 4–6 feet, on gray sandbar (2); north of east end of El Mogote, 1 fm., black sand (2); east point of El Mogote, low tide on sandy beach (dead) (4); ½ mile southeast of Prieta Point, 2 fms., gray sand (1); 2½ miles north of La Paz, 1–2 fms., on bar off Caruanito Roek, gray sand (1).

San Carlos Bay, 25° 18'N., 2–3 fms., fine black sand bottom, Hawkins (1).

Conception Bay, west end of Coyote Bay, 26° 53'N., 10–12 feet in cove, Hawkins (1).

Santa Inez Bay, 27° N., Hawkins: 2 miles west of Santa Inez Point, 4½ fms., ½ mile offshore in coarse gray sand (6); west around Santa Inez Point, 6–12 feet in cove, fine black sand (40), types.

*Republic of Panama*

Panama City, 8° 50'N., Zetek (5).

Panama, Zetek (9) [tips broken].

*Galápagos Islands*

Near Galápagos Islands, 1° 21'N., 89° 40'W., U.S.F.C. 2813, 40 fms. (25±) [tips broken].

REFERENCES

- DALL, W. H. *Reports on results of dredging . . . by the U. S. Coast Survey steamer Blake . . . , XXIX: Mollusca; pt. 2: Gastropoda and Scaphopoda*. Bull. Mus. Comp. Zool. **18**: 492 pp., 40 pls. 1889.
- HENDERSON, JOHN B. *A monograph of the East American scaphopod mollusks*. U. S. Nat. Mus. Bull. 111: 177 pp., 20 pls. 1920.
- PHILIPPI, R. A. *Enumeratio molluscorum Siciliae* **2**. 1844.
- VERRILL, A. E. *Catalogue of Mollusca recently added to the fauna of the New England coast and the adjacent parts of the Atlantic . . .* Trans. Connecticut Acad. Arts and Sci. **6**: 139–294, 5 pls.; 395–452, 3 pls. 1884.

ZOOLOGY.—*The brittle-stars of the United States Navy Antarctic Expedition 1947–48*.<sup>1</sup> AUSTIN H. CLARK, U. S. National Museum.

In a previous article (this JOURNAL, **40**: 335–337, 1950) the Crinoidea, Echinoidea, and Asteroidea of the Navy's Antarctic Expedition of 1947–48 were described. The collection includes 11 species of Ophiuroidea, none of them new although several are of much interest.

The literature on the Antarctic echinoderms has recently been brought up to date by the magnificent series of *Discovery* reports based upon the work of the *Discovery*, *Discovery II*, and *William Scoresby* from 1925 to 1935. In this series the report on the Echinoidea and Ophiuroidea by Th. Mortensen was published in 1936; on the Crinoidea (with bibliography) by D. Dilwyn John in 1938; and on the Asteroidea (with bibliography) by Walter K. Fisher in 1940.

<sup>1</sup> Published by permission of the Secretary of the Smithsonian Institution. Received September 5, 1950.

A detailed account of the faunal relations of the Asteroidea, Ophiuroidea, and Echinoidea was published by René Koehler in 1912 (*Deuxième Expédition Antartique Française, 1908–1910, Échinodermes*, pp. 186–253), and of the Crinoidea by the present author in 1915 (*Die Crinoïden der Antarktis*).

OPHIUROIDEA

OPHIACANTHIDAE

*Ophicantha disjuncta* (Koehler)

*Ophiodiplax disjuncta* Koehler, British Antarctic Expedition 1907–9, **2**, Biology, pt. 4: 48, pl. 6, figs. 9, 10, 11, pl. 7, fig. 13. 1911.

*Localities*.—Lat. 66° 35' S., long. 90° 40' E.; 150 fathoms; water temperature (surface) 29° F.; December 30, 1947 (1 specimen, U.S.N.M. no. E.7689).

Marguerite Bay; 35 fathoms; water temper-

ature 30° F.; February 20, 1948 (1 specimen, U.S.N.M. no. E.7690).

*Notes*.—In the specimen from lat. 66° 35' S., long. 90° 40' E. the disk is 12 mm in diameter and the arms are 80 mm long. In the specimen from Marguerite Bay in 35 fathoms the disk is 7 mm in diameter; the arms are 35 mm long.

#### AMPHIURIDAE

##### *Amphiura algida* Koehler

*Amphiura algida* Koehler, British Antarctic Expedition 1907-9, 2, Biology, pt. 4: 46, pl. 7, figs. 14, 15. 1911.

*Locality*.—Off Cape Royds, Ross Island; 58 fathoms; January 29, 1948 (20 specimens, U.S.N.M. nos. E.7687, E.7688).

*Notes*.—In the largest specimens the disk is 5 mm in diameter and the arms are 25 mm long. The radial shields are in contact from only at their outer ends to about their whole length, and are slightly broader than is shown in Koehler's figure. The arm spines at the base of the arms are 5, sometimes 6.

##### *Amphiura belgicae* Koehler

*Amphiura belgicae* Koehler, Resultats du voyage de S. Y. *Belgica* en 1897-1898-1899, Rapports Scientifique, Zoologie, Échinides et Ophiures: 27, pl. 7, figs. 46-48. 1901.

*Localities*.—Off Cape Royds, Ross Island; 58 fathoms; January 29, 1948 (3 specimens, U.S.N.M. no. E.7683).

Marguerite Bay; 35 fathoms; water temperature 30° F.; February 20, 1948 (2 specimens, U.S.N.M. no. E.7682).

*Notes*.—One of the specimens from off Cape Royds has the disk 8 mm in diameter and the arms 40 mm long. One basal side arm plate has 5 arm spines; the others have 4 spines. The two specimens from Marguerite Bay have the disk 10 mm in diameter and the arms about mm long; the first four side arm plates beyond the disk have 5 arm spines.

#### OPHIOLÉPIDIDAE

##### *Ophiomastus ludwigi* Koehler

Figs. 1, 2

*Ophiomastus ludwigi* Koehler, Resultats du voyage de S. Y. *Belgica* en 1897-1898-1899, Rapports Scientifique, Zoologie, Échinides et Ophiures: 23, pl. 3, fig. 22, pl. 4, figs. 27, 28. 1901.

*Locality*.—Marguerite Bay; 35 fathoms; water temperature 30° F.; February 20, 1948 (2 specimens, U.S.N.M. no. E.7979).

*Notes*.—Although there is considerable difference in some details, there can be no doubt that the larger specimen (Fig. 1) represents the same species as the single specimen described as *Ophiomastus ludwigi*, which was dredged near Peter Island (lat. 71° S., long. 88° 02' W.) in 600 meters.

It is smaller than the type with the disk 3 mm in diameter and the arms 7 mm long and, like the type, is immature without genital slits. The plates of the disk are somewhat irregular. On the first tentacle pore there are three scales on the interradial side, one on the radial; on the second pore there are two or three scales on the outer side, none on the inner; on the four or five following pores there is a single small scale at the base of the lower arm spine; there are no scales on the following pores. There are two arm spines, rather widely spaced.

A smaller specimen (Fig. 2) with the disk 1.7 mm. in diameter and the arms 5 mm long probably belongs to the same species. The primary radial plates are in contact, and portions of the radial shields are visible beyond them, as in Koehler's specimen. As in the larger specimen the disk is thick, but not domed. The first five upper arm plates, which are not in contact and decrease in size outwardly from the disk, are greatly swollen. The arms are more slender than those of the larger specimen with much elongated and narrow side arm plates and very small upper and under arm plates. There are two arm spines and no tentacle scales.

##### *Ophiura serrata* Mortensen

Figs. 3, 4

*Ophiura serrata* Mortensen, *Discovery Reports* 12, Echinoidea and Ophiuroidea: 334, fig. 47, a-d, 335. 1936.

*Locality*.—Marguerite Bay; 35 fathoms; water temperature 30° F.; February 20, 1948 (2 specimens, U.S.N.M. no. E.7980).

*Notes*.—These specimens undoubtedly represent the species called *Ophiura serrata* by Mortensen, though they differ from that species as described in having fewer and more regular plates on the dorsal side of the disk and in the ventral interradial areas, in having only two well-separated arm spines, and in lacking any evidence of arm combs, all features presumably due to immaturity.

The upper arm plates are high and roundedly carinate, separated from each other by a conspicuous notch. In the smaller specimen they are

especially high at the arm bases where they are separated by a rather broad V-shaped notch. Distally they become gradually lower and smaller, more and more widely separated, and minute in the distal half of the arm. In lateral view the basal part of the arm appears swollen.

In the larger specimen the disk is 5 mm in diameter and the arms are 13 mm long; in the smaller the disk is 3 mm in diameter and the arms are 10 mm long.

***Ophiura rouchi* (Koehler)**

*Ophioglypha rouchi* Koehler, Deuxième Expédition Antarctique Française (1908-1910), Échinodermes (Astéries, Ophiures et Échinides): 107, pl. 9, figs. 11, 12. 1912.

*Localities*.—Off Cape Royds, Ross Island; 58 fathoms; January 29, 1948 (2 very small specimens, U.S.N.M. no. E.7707).

Marguerite Bay; 35 fathoms; water temperature 30° F.; February 20, 1948 (4 specimens, U.S.N.M. no. E.7684).

*Notes*.—The specimens from Marguerite Bay have the disk 5 mm. in diameter and the arms 30 mm. long.

***Ophiurolepis gelida* (Koehler)**

*Ophioglypha gelida* Koehler, Bull. Acad. Belgique, 1900: 819; Resultats du voyage du S. Y. *Belgica* en 1897-1898-1899, Rapports Scientifiques, Zoologie, Échinides et Ophiures: 17, pl. 1, figs. 6-8. 1901.

*Localities*.—Off Cape Royds, Ross Island; 58 fathoms; January 29, 1948 (27 specimens, U.S.N.M. nos. E.7679, E.7680, E.7685).

Marguerite Bay; 35 fathoms; water temperature 30° F.; February 20, 1948 (2 specimens, U.S.N.M. no. E.7678).

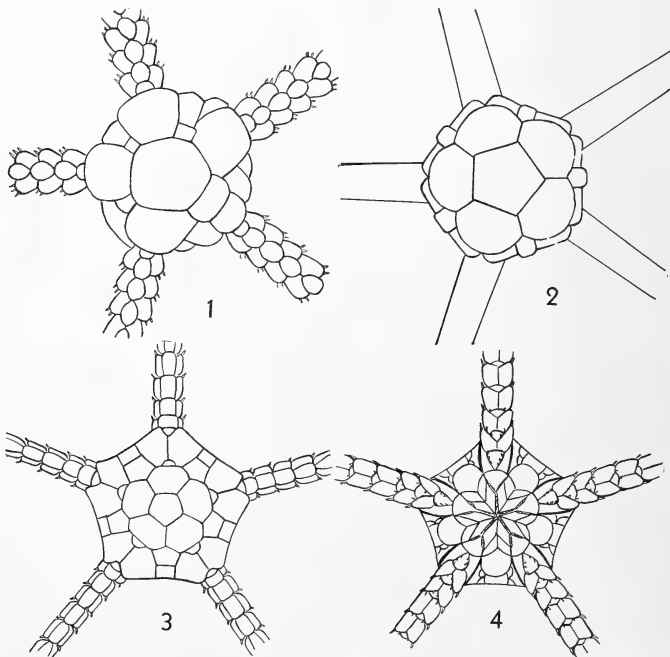

FIGS. 1-4.—1, 2, *Ophiomastus ludwigi*: 1, Specimen with the disk 3 mm in diameter; 2, specimen with the disk 1.7 mm in diameter. 3, 4, *Ophiura serrata*, aboral (3) and oral (4) surfaces.

*Notes*.—The largest specimen from off Cape Royds has the disk 11 mm. in diameter and the arms 35 mm long. One specimen is 4-rayed. The largest specimen from Marguerite Bay has the disk 12 mm in diameter and the arms 35 mm long.

**Ophiurolepis martensi** (Studer)

*Ophioglypha martensi* Studer, Jahrb. wiss. Anst. Hamburg 2: p. 161, pl. 2, figs. 8, a, b. 1885.

*Localities*.—Off Cape Royds, Ross Island; 58 fathoms; January 29, 1949 (11 specimens, U.S.N.M. nos. E.7705, E.7706).

Marguerite Bay; 35 fathoms; water temperature 30° F.; February 20, 1948 (5 specimens, U.S.N.M. no. E.7704).

**Ophionotus victoriae** Bell

*Ophionotus victoriae* Bell, Report Coll. Nat. Hist. . . . *Southern Cross*: 216. 1902.—Koehler, Deuxième Expédition Antarctique Française (1908–1910), Échinodermes (Astéries, Ophiures et Échinides): 114, pl. 10, figs. 2–4, 12, 13, pl. 11, fig. 8. 1912.

*Localities*.—Lat. 65° 25' S., long. 101° 13' E.; 100 fathoms; water temperature 30° F.; January 14, 1948 (10 specimens, U.S.N.M. no. E.7676)

Peter Island; 30 fathoms; water temperature 29.6° F.; February 15, 1948 (124 specimens, U.S.N.M. nos. E. 7658, E.7659, E.7660, E.7663, E.7664, E.7665, E.7666, E.7669, E.7670, E.7671, E.7672, E.7673, E.7674, E.7675).

Peter Island; 60 fathoms; February 15, 1948 (1 specimen, U.S.N.M. no. E.7668).

Marguerite Bay; 35 fathoms; water temperature 30° F.; February 20, 1948 (22 specimens, U.S.N.M. nos. E.7661, E.7662).

Marguerite Bay; 40 fathoms; water temperature 30° F.; February 22, 1948 (8 specimens, U.S.N.M. no. E.7667).

*Notes*.—The specimens from lat. 65° 25' S., long. 101° 13' E. with the disk up to 27 mm in diameter have the disk less rounded and more pentagonal than the others; the arm spines are more slender and delicate and the mouth papillae less stout and more sharply pointed. The arms are longer and more slender, a specimen with the disk 23 mm in diameter having the arms 120 mm long, and one with the disk 16 mm in diameter having the arms 80 mm long.

The specimens from Peter Island in 30 fathoms have the disk from 4 to 25 mm in diameter.

The specimen from Peter Island in 60 fathoms has the disk 20 mm in diameter.

In the specimens from Marguerite Bay in 35 fathoms the disk is up to 27 mm in diameter.

One of those from Marguerite Bay in 40 fathoms has the disk 28 mm in diameter.

**Ophiosteira senoqui** Koehler

*Ophiosteira senoqui* Koehler, Deuxième Expédition Antarctique Française (1908–1910), Échinodermes (Astéries, Ophiures et Échinides): 110, pl. 10, figs. 8–11. 1912.

*Locality*.—Off the Knox Coast (lat. 66° 31' S., long. 110° 26' E.); 100 fathoms; January 19, 1948 (1 specimen, U.S.N.M. no. E.7681).

*Note*.—In this specimen the disk is 20 mm. in diameter and the arms are 120 mm long.

**Ophiocten megaloplax** Koehler

*Ophiocten megaloplax* Koehler, Bull. Acad. Belgique, 1900: 819; Résultats du voyage du S. Y. *Belgica* en 1897–1898–1899, Zoologie, Échinides et Ophiures: 22, pl. 6, figs. 38, 39. 1901.

*Localities*.—Lat. 66° 35' S., long. 90° 40' E.; 150 fathoms; water temperature (surface) 29° F.; December 30, 1947 (1 specimen, U.S.N.M. no. E.7692).

Lat. 65° 25' S., long. 101° 13' E.; 100 fathoms; water temperature 30° F.; January 14, 1948 (2 specimens, U.S.N.M. no. E.7693).

Off the Knox Coast (lat. 66° 31' S., long. 110° 26' E.); 100 fathoms; January 19, 1948 (1 specimen, U.S.N.M. no. E.7691).

*Notes*.—The specimen from lat. 66° 35' S., long. 90° 40' E. in 150 fathoms has the disk 5.5 mm in diameter and the arms 25 mm long. The specimen from off the Knox Coast has the disk 8 mm. in diameter, with the circular central plate 3 mm in diameter, and the arms 35 mm long.

ASSOCIATION OF SPECIES (CRINOIDEA,  
ÉCHINOIDEA, ASTEROIDEA,  
AND OPHIUROIDEA)

Ross Island; caught along the beach near Cape Royds; January 29, 1948. *Odontaster validus*.

Off Cape Royds, Ross Island; 58 fathoms; January 29, 1948. *Sterechinus antarcticus*, *Odontaster validus*, *Amphiura algida*, *Amphiura belgicae*, *Ophiura rouchi*, *Ophiurolepis gelida*, *Ophiurolepis martensi*, *Amphiurid*.

Marguerite Bay; littoral; February 22, 1948. *Labidiaster annulatus*. Tide pools along shore on an island in Marguerite Bay; February 21, 1948. *Sterechinus antarcticus*, *Acondontaster elongatus*, *Lysasterias perrieri*, *Lysasterias joffrei*,

*Adelasterias papillosa*. Dredged at 35 fathoms; temperature 30° F.; February 20, 1948. *Promachocrinus kerguelensis*, *Sterechinus antarcticus*, *Leplychaster magnificus*, *Psilaster charcoti*, *Odontaster meridionalis*, *Odontaster validus*, *Acodontaster elongatus*, *Perknaster aurantiacus*, *Remaster gourdoni*, *Adelasterias papillosa*, *Ophiacantha disjuncta*, *Amphiura belgicae*, *Ophiomastus ludwigi*, *Ophiura serrata*, *Ophiura rouchi*, *Ophiurolepis gelida*, *Ophiurolepis martensi*, *Ophionotus victoriae*. Dredged at 40 fathoms; temperature 30° F.; February 22, 1948. *Promachocrinus kerguelensis*, *Sterechinus antarcticus*, *Odontaster validus*, *Cuenotaster involutus*, *Lysasterias perrieri*, *Ophionotus victoriae*. Dredged at 35-105 fathoms; temperature 30.2° F.; February 19, 1948. *Sterechinus antarcticus*. Dredged at 115 fathoms temperature 30.2° F.; February 18, 1949. *Sterechinus antarcticus*, *Odontaster validus*.

Off Peter I Island; 30 fathoms; temperature 29.6° F.; February 15, 1948. *Psilaster charcoti*, *Ophionotus victoriae*. Same, 60 fathoms; February 15, 1948. *Ophionotus victoriae*.

Lat. 66° 35' S., long. 90° 40' E.; 150 fathoms; December 30, 1947. *Ophiacantha disjuncta*, *Ophiocten megaloplax*.

Lat. 65° 25' S., long. 101° 13' E.; 110 fathoms; temperature 30° F.; January 14, 1948. *Florometra mawsoni*, *Ophionotus victoriae*, *Ophiocten megaloplax*.

ZOOLOGY.—*A new genus and species of notodelphyoid copepod from Japan.*<sup>1</sup> PAUL L. ILLG, U. S. National Museum.

In the course of assembling a series of notodelphyoid copepods for revisionary studies, a fruitful source of material has been found in the yet unclassified collections of tunicates in the National Museum. The distinctive form here described has been selected for immediate treatment as a testimonial to the retiring curator of echinoderms, United States National Museum, Austin Hobart Clark. It is considered an appropriate token of Mr. Clark's significant connections with the United States Fish Commission steamer *Albatross*, the collecting vessel, and of his pioneer interest in the zoogeographic features of Japanese waters.

<sup>1</sup> Published by permission of the Secretary of the Smithsonian Institution. Received October 6, 1950.

Lat. 66° 31' S., long. 110° 26' E.; 100 fathoms; January 9, 1948. *Promachocrinus kerguelensis*, *Ophiosteira senoqui*, *Ophiocten megaloplax*.

It is interesting to compare the representation of the different classes of echinoderms (exclusive of the holothurians) in the Antarctic and the Arctic. The number of species in each region is as follows:

	Antarctic	Arctic
Crinoidea.....	24	3
Echinoidea.....	30	2
Asteroida.....	114	23
Ophiuroidea.....	50	12

This enumeration does not include the fauna of the subantarctic islands or the Magellanic region, which support many additional species mostly related to Antarctic types.

The strictly Antarctic species are almost wholly confined to the immediate vicinity of the Antarctic continent, while the majority of the Arctic species range for a greater or lesser distance southward in the north Atlantic, a few also in the north Pacific, and there is an isolated Arctic colony in the very cold water of the eastern part of the Seas of Okhotsk and Japan. A few Antarctic types range northward along the west coast of South and North America. Thus among the crinoids *Ptilocrinus* reaches British Columbia, *Ilycrinus* occurs off southeastern Alaska and westward to the Commander Islands, and *Florometra* extends northward to the Aleutian Islands, and south in the west Pacific to southern Japan.

The generic name here proposed is derived as an anagram of Mr. Clark's given name.

#### Family NOTODELPHYIDÆ

Subfamily NOTODELPHYINÆ Schellenberg, 1922

#### *Ustina*, n. gen.

The description below of the characters of the genotype and only species, *Ustina clarki*, n. sp., provides the generic definition.

#### *Ustina clarki*, n. sp.

*Specimens examined*.—23 females, 18 males, all adult; from branchial cavities of numerous specimens of a small species of solitary ascidian. *Albatross* station 3698, off Manazuru Zaki, N.8°, W. 4.5 miles, inside Sagami Bay, Honshu Island, Japan, 153 fathoms, May 5, 1900.



*Types*.—Holotypic female, U.S.N.M. no. 91090; allotypic male no. 91091; paratypes no. 91092; all from the one known collection; scientific name of ascidian host not known.

*Description*.—FEMALE (Figs. 1, *a-o*): General aspect (Fig. 1, *a*) marked by the heavy chitinization of the body, with resultant characteristic rigidity of the major body units, and, in addition, an extremely notable compression of the metasome. The heavy body cuticle is densely set with perforating conical pores which reach from wide bases to much diminished surface apertures. There seem to be no structures projecting beyond the apertures. The metasome is 5-segmented. The fused cephalothoracic portion includes the somites of all the mouthparts. The segment of the first swimming legs is free and much shorter than the other thoracic segments. The somite of the fourth legs almost equals in bulk the remainder of the metasome by reason of its voluminous dorsal and posterior expansion to accommodate the characteristic incubatorium. The eggs are large and rather few in number. They form a compact mass which somewhat intrudes anteriorly into the third free somite.

The urosome (Fig. 1, *b*) is 5-segmented, somewhat elongate and cylindrical. The very short somite of the fifth legs is succeeded by three long, subequal segments and a very short, but highly characteristic, terminal segment. The anal somite bears a greatly enlarged ventral projection, pear-shaped in lateral view, wide and faintly bilobed from ventral aspect. This prominence is further marked by a very thick cuticle, densely set with the porelike structures described above. The caudal rami are widely spaced and project ventrolaterally from the sides of the segment.

An axis through the body measures over-all 2.2 mm. The separate lengths of the metasome and urosome, as measured along their major axes, are respectively 1.75 mm and 1.15 mm.

The head (cephalothorax) is triangular in side view. The ventral margin of the notal shield is markedly indented subapically at the point of emergence of the antennular bases. The notum is produced ventrally and posteriorly over the bases of the antennules as a wide-based, roughly triangular rostrum, with rounded apex.

The antennule (Fig. 1, *c*) is 8-segmented and densely setiferous. The base is more or less enveloped by the ample rostrum. The typical posture would appear to be that resulting from a sharp elbow bend of the third segment upon the second. The basal two segments are much the

widest, the six distal to the flexure taper gradually to the narrow tip which is about one-seventh the basal width of the first segment. The setation has not been depicted fully in the figure nor was an exact count attempted. All the segments are heavily chitinized and the setae are consistently long, slender and profusely plumose.

The antenna (Fig. 1, *d*) is 3-segmented. The basal segment is much the longest, almost equaling the combined lengths of the distal segments. It bears distally a well-developed, elongate, plumose seta. The two terminal segments are subequal. Segment 2 bears a short slender seta subapically. Segment 3 has the usual stout, curved, tapered hook, articulated on the distal surface. Set in relation to this terminal jointing are 5 setae. More proximally there is a trio of subequal setae which lie closely appressed to the surface. Still more proximal is a short slender seta. The basal segment bears a characteristic marginal row of very long, fine cilia.

The masticatory plate of the mandible (Fig. 1, *e*) is best presented by illustration. The mandibular palp (Fig. 1, *f*) shows some tendency to suppression of the endopodite. Some of the setae are stout, elongate and plumose, but several are reduced to relatively short and slender dimensions. The two segments are subequal. The basal segment bears 4 setae at the distal medial corner. The terminal segment bears 8 setae arranged across the truncate end and along the medial margin. The basipodite bears a relatively small subapical seta. The exopodite is a flattened, rigid plate with no remaining evidence of segmentation other than its 5 graduated, long, plumose setae.

The maxillule (Fig. 1, *g*) is ornamented with relatively long, profusely plumose setae. The principal endite of the coxopodite bears a row of nine stout, short, tapered setae. The next distal medial process (a second endite?) is directly prolonged as a sharply tapering, flattened seta, profusely set with marginal ciliation. The basipodite bears medially three long, graduated setae, all plumose. The shortest is proximal and equals about two-thirds the length of the distally placed longest. The middle seta is intermediate in length. The endopodite bears four long, plumose setae, two borne terminally and two on the medial margin. The exopodite is slightly more expanded than the endopodite and has three setae widely spaced along its somewhat truncate margin. The epipodite is set with a long plumose seta, directed basally and with a more distally placed, very short, sharply tapered auxiliary seta.

The maxilla (Fig. 1, *h*) is seemingly of primitive construction. It is 5-segmented; each segment bears one or more profusely ciliated, elongate setae. The basal segment bears a proximal trio of long setae, set more or less transversely to the main axis of the appendage on a well-developed protuberance. The next distal medial prominence bears a single long, plumose seta. The third prominence has a pair of equal, long, plumose setae. The terminal prominence of the segment bears two equal plumose setae; set at the base of these is a very short auxiliary seta. The second segment bears a pair of setae with an accompanying, basally placed, short auxiliary seta. The more proximal of the principal setae is equivalent in length to those of the basal segment. The distal seta is about two-thirds as long as the other, of about the same thickness; it is the homologue of the heavily developed claw that occurs in many closely related notodelphyoids. The third segment bears one plumose seta; the fourth segment is distinctively set with one long, plumose seta and a second, much shorter and slenderer seta. The terminal segment bears a distally arranged trio of plumose setae, one of which is equivalent in dimensions with the majority of the setae of the appendage, the remaining two shorter and slenderer by about one-third. All are plumose.

The maxilliped (Fig. 1, *i*) is a flat, unsegmented plate, preserving, however, indications of direct derivation from a 2-segmented condition. A distal pair of subequal, long, plumose setae is set on a well demarcated projection of the appendage. The medial margin bears two quartets of roughly equal, short, plumose setae.

The swimming legs are distinctive as indicated in the figures and in the following tabulation of arrangement of setae and spines. Setae are designated in Arabic numerals following designation of spines in Roman. The segments of each ramus are accounted for in order from the basal segment distally. First exopodite I-1; I-1; IV-3; first endopodite O-0; O-6. Second exopodite I-1; I-1; V-4; second endopodite O-1; O-8. Third exopodite I-1; I-1; IV-4; third endopodite O-1; O-8. Fourth exopodite I-1; I-1; IV-3; fourth endopodite O-1; O-7.

All the legs are heavily chitinized. None bears medial setae on the coxopodite. All bear a seta, variously developed, at the lateral edge of the basipodite. The endopodites are all 2-segmented. The lengths of the exopodites are graduated, the fourth being at least twice as long as the first. The elongation is mainly due to increased produc-

tion of the terminal segment of each exopodite.

In the first legs (Fig. 1, *j*) the rami are subequal. The lateral seta of the coxopodite is very long, stout and plumose. The basipodite bears medially a stout, curved, tapered spine which reaches to about the beginning of the distal third of the terminal segment of the endopodite. The setae of the terminal segment of the exopodite are short, exceeding the inner terminal spine by about half its length. The endopodite (Fig. 1, *k*) is highly distinctive; it is heavily chitinized. The elongate, terminal segment curves laterally and distally. The setae are all very long and profusely plumose.

In the second legs (Fig. 1, *l*) the endopodite reaches slightly beyond the second segment of the exopodite. The terminal exopodite segment is slightly shorter than the combined lengths of the two proximal segments. The third endopodite reaches just beyond the second segment of the third exopodite. The terminal segment of the latter exceeds the combined lengths of the proximal two segments by about one-third. In the fourth legs (Fig. 1, *m*) the endopodite does not quite reach to the distal margin of the second segment of the exopodite. The length of the distal segment of the exopodite exceeds the proximal segments by half again their combined lengths. The setae of these swimming legs are in the main very long and plumose. Notably excepted are the setae of the third and fourth exopodites. These are short and slender; their consistency approaches more or less that of the spines and they lack the usual plumose ciliation.

The fifth legs (Fig. 1, *n*) are much reduced. In general aspect they are reminiscent of those in *Botachus*. The basal portion is more or less coalesced with the substance of the somite. A plumose lateral seta is borne on a slightly elevated basal prominence. The free segment is short and narrow. It bears a medial subapical spine and a relatively short terminal seta. The basal plate and free segment are heavily chitinized. The terminal seta is seemingly lacking in ornamentation.

The caudal rami (Fig. 1, *o*) are flat, heavily chitinized plates. The armature consists of a long, terminal, articulated claw, a more proximal, short, heavy, spinelike claw, and 3 short setae.

MALE (Figs. 1, *p*, *q*): a more or less generalized notodelphyoid type, possibly tending somewhat to compression of the metasome. The integument is of normal aspect, lacking the marked sclerotization seen in the female. There are no cuticular pores detectable in the specimens seen. The meta-

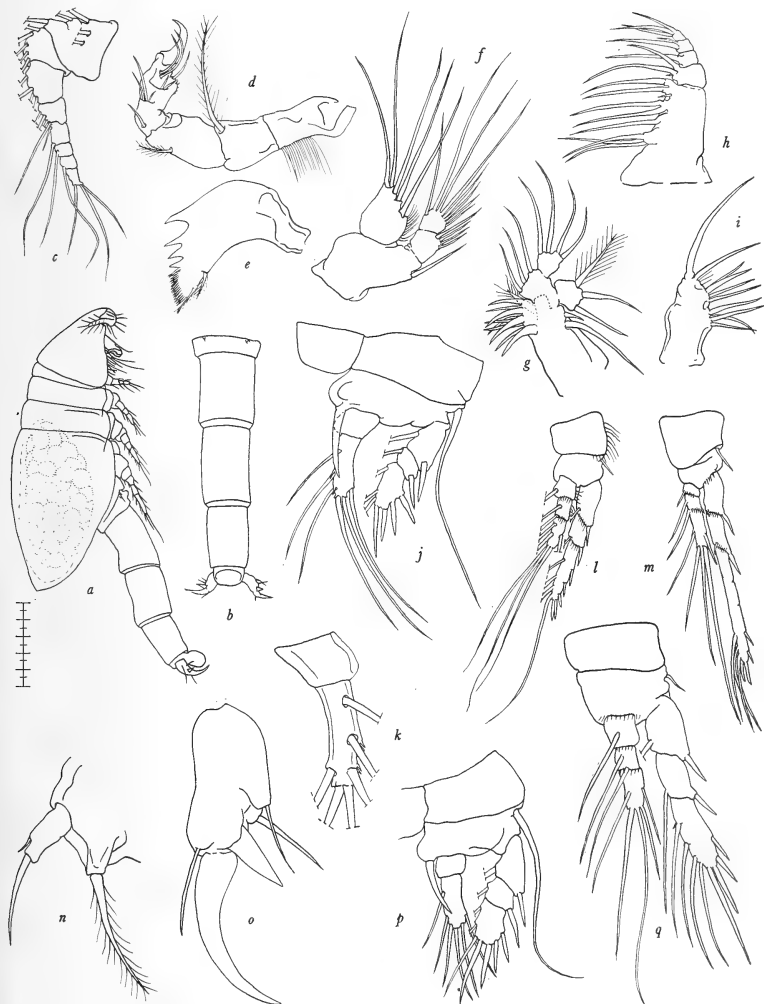

FIG. 1.—*Ustina clarki*, n. sp. Female: *a*, Habit, lateral view; *b*, urosome, ventral view; *c*, antennule; *d*, antenna; *e*, masticatory plate of mandible; *f*, mandibular palp; *g*, maxillule; *h*, maxilla; *i*, maxilliped; *j*, first leg; *k*, first endopodite; *l*, second leg; *m*, fourth leg; *n*, fifth leg; *o*, caudal ramus. Male: *p*, First leg; *q*, fourth leg. The scale, referring only to the figure of the habit of the female, represents 0.5 mm. To avoid complication of detail the plumose ciliation of most setae depicted has been omitted; this detail can be supplied from the description.

some is 5-segmented, comparable, except for the lack of the inflated incubatory structures, to the tagmosis in the female. The urosome is 6-segmented, modified in its thoracic component by the complicated male reproductive structures. The first urosomal somite is short and bears at its posterior margin fifth legs entirely comparable with those in the female. The second segment is twice as long and bears the usual sixth leg lappets, each terminating in a prolongation bearing two subequal setae. The succeeding three segments are subequal; the first of these is half again as long as the combined lengths of the first two segments. The terminal somite is comparable to that in the female, heavily chitinized, but lacking the elaborately developed cuticular structure of the other sex.

None of the cephalic or thoracic appendages, other than the sexually modified sixth legs exhibits specialization toward copulatory prehension. The head appendages and maxillipeds are comparable to those in the female, although of smaller absolute dimensions and with somewhat less substantial structure. The swimming legs are not so modified as those in the female, retaining a more generalized aspect. The segmentation differs by the fact that the endopodites of the second, third and fourth legs preserve the basic 3-segmented condition. The ornamentation differs from that in the female in the following particulars: second endopodite O-1; O-2; O-6. Third endopodite O-1; O-2; O-6. Fourth exopodite I-1; I-1; IV-4; fourth endopodite O-1; O-2; O-5.

The first legs (Fig. 1, *p*) exhibit segmentation and ornamentation comparable to that in the female, but with over-all reduction in size and substance. The exopodites in the second through fourth legs exceed the endopodites by about the length of the terminal exopodite segments. These terminal segments in each case are shorter than the combined lengths of each two basal segments. The fourth leg (Fig. 1, *q*) is depicted to show the departure in configuration of segments and degree of ornamentation from the condition in the female.

The length of the male is 1.1 mm.

*Remarks.*—The copepod here described raises some difficulty when an attempt is made to place it in the scheme of classification of the notodelphoids. The existing generic definition most aptly accommodating its characteristics would be *Notopterophoroides* Schellenberg, 1922. However, when characters of the present species, those of *Botachus*, the species of *Notopterophorus*, *Pachy-*

*pygus* and the two species of *Notopterophoroides* are compared, it would seem as though a set of variations around a basic ground plan is discernible. Unifying characters would be: considerable similarity of antennule; general similarity of construction of mandibular palp; more or less graduated reduction in maxillular ornamentation, in structure of maxilla, and of maxilliped; individual but more or less consistent modifications of swimming legs; reduction of fifth legs; and great similarity of construction of urosome with markedly consistent modification of the anal somite and caudal rami. It seems supportable that here among the notodelphoids is still another series of related forms comparable to the groups varying around the *Notodelphys* mode and the *Doropygus* mode respectively. The present series exhibits characters (structure of antennule, for instance) which might be considered more primitive than those of *Doropygus*; others indisputably are more highly derived. By comparison with *Notodelphys* some of this group display a possibly more basic condition in having the somite of the first swimming legs a free segment. Since very probably there are yet undiscovered a considerable number of notodelphoids which might furnish elucidation of the so far seemingly random distribution of the basic characters, it seems best at the present level of knowledge to indicate supraspecific identity as strongly as possible. Accordingly separation is here recognized of all the aforementioned genera, and for the newly described form generic status is proposed. The species of *Notopterophoroides* seem to be rather arbitrarily united in the generic delimitation. Since Lang, 1949, by designation of *N. armadillo* Schellenberg as genotype has fixed the generic concept, the second species, *N. malacodermatus* Schellenberg, seems only questionably appropriately referable to the genus. However, until the discovery of other species and clarification of the characters of the latter species, it seems preferable to refrain from attempting further generic separation.

#### REFERENCES

- LANG, K. *Copepoda "Notodelphyoida" from the Swedish west-coast with an outline on the systematics of the copepods.* Arkiv. för Zool. **40A** (No. 14): 1-36, 1 pl., 17 figs. 1949.
- SCELLENBERG, A. *Neue Notodelphyiden des Berliner und Hamburger Museums mit einer Übersicht der ascidienbewohnenden Gattungen und Arten. I. Teil.* Mitteil. Zool. Mus. Berlin **10** (2): 217-274, 43 figs. 1922.

ZOOLOGY.—*The grass shrimps of the genus Hippolyte from the west coast of North America.*<sup>1</sup> FENNER A. CHACE, JR., U. S. National Museum.

Two species of *Hippolyte* have been described from the Pacific coast of North America. One, *Hippolyte californiensis*, has been recorded from several localities between Sitka, Alaska, and Santa Inez Bay, Baja California. The other, *H. mexicana*, was described by me from a series of mutilated specimens from the latter locality. I am now convinced that *H. mexicana* represents the previously undescribed male of *H. californiensis*. Examination of material in the collections of the U. S. National Museum indicates, however, that specimens from the northern part of the recorded range of *H. californiensis* are very distinct from those from the southern part and that they belong to a hitherto undescribed species.

It is a pleasure to name this species after Austin H. Clark, retiring curator of echinoderms, U. S. National Museum, in recognition not only of his outstanding contributions to our knowledge of many groups of animals but, especially, of his even broader influence on natural history through the assistance and encouragement he always has ready for biologists whose major goals still lie ahead.

*Hippolyte californiensis* Holmes

Figs. 1, a-e

*Hippolyte californiensis* Holmes, 1895, p. 576, pl. 20, figs. 21-26 (type locality, Bodega Bay, Calif.; cotypes, U.S.N.M. no. 18697); 1900, p. 193.—Rathbun, 1904, p. 56 (part).—Schmitt, 1921, p. 48 (part), figs. 26, a-b (not fig. 26, c); 1924a, p. 165 (part); 1924b, p. 387.—Chace, 1937, p. 126.  
*Hippolyte mexicana* Chace, 1937, p. 127, fig. 6 (type locality, Santa Inez Bay, Baja California, Mexico; holotype, no. 361076, Department of Tropical Research, New York Zoological Society).

*Female*.—Carapace not inflated. Four pairs of subequally spaced tufts of plumose setae on dorsal part of carapace. Supraorbital spine reaching forward about as far as, or slightly beyond, hind margin of orbit. Antennal spine small, separated by a U-shaped notch from suborbital angle; the latter is blunt, but produced nearly or quite as

far as the antennal spine. Branchiostegal spine prominent and set far back from anterior margin of carapace, the tip falling short of the margin by at least half the length of the spine.

Rostrum reaching not quite as far as, or a little beyond, end of antennal scale. Upper margin straight, or a little concave, and armed with three or four teeth behind the tip. The tip is usually bifid, the upper tooth overreaching the lower. Lower margin set on a very narrow crest, slightly wider than the dorsal one, and armed with three to five teeth behind the tip. Supporting ridge on each lateral face of rostrum very sharp posteriorly, becoming blunt and finally indistinct on the anterior half.

Third somite of abdomen produced in a very low, rounded cap over anterior portion of fourth somite. There is a tuft of plumose setae on each side of the cap near the margin, and another pair near the middle. Fifth somite unarmed. Sixth somite one and three-fourths times as long as fifth. Telson as long as sixth somite, flattened dorsoventrally, and armed with two pairs of lateral spines, the anterior pair inserted not quite half way from the base to the tip of the telson, and the posterior pair about midway between the first pair and the tip; there are six or seven terminal spinules, the two submedian pairs about subequal in length and longer than the lateral pair.

Cornea of eye wider than stalk and not reaching as far forward as tip of stylocerite. Stylocerite slender, sharp, and separated from main portion of segment by a narrow emargination. First antennular segment armed with an outer distal spine (and sometimes a smaller spine medially to the first). Second segment about twice as long as third. Inner flagellum made up of 18 to 22 segments, the outer one of 9 to 11 segments the first 6 to 8 of which are somewhat inflated. Antenna with a lower spine on basis. Scale narrow with subparallel sides, the inner angle of the blade strongly produced far beyond the outer spine.

External maxillipeds rather stout and reaching somewhat beyond the tip of the spine on the basis of the antenna. The exopod is well developed. First legs robust, unarmed; carpus distinctly longer than palm. First joint of carpus of second legs a little over twice as long as second,

<sup>1</sup> Published by permission of the Secretary of the Smithsonian Institution. Received October 6, 1950.

which is about three-fourths as long as third (one specimen examined has the second joint fully as long as the third); chela usually shorter than combined lengths of second and third joints of carpus. Third leg reaching forward nearly as far as end of antennular peduncle; merus with three to five lateral spines; carpus with one; propodus very slender, armed ventrally with about seven spines, increasing in size distally; dactyl long and slender, with three stout spines at tip and ten to thirteen on lower margin, increasing in size distally. Fourth leg extending forward about as far as end of antennal peduncle; merus armed with three lateral spines; carpus

with one; propodus and dactyl as in third leg. Fifth leg reaching forward to terminal third of basis of antenna; merus and carpus armed with one spine each; propodus and dactyl as in leg 3.

*Male*.—Rostrum slender, reaching about to middle of second antennular segment, and straight or slightly downcurved throughout its length. Rostral margins subparallel, armed dorsally with two to four, usually three, teeth, and ventrally with one to three, usually two, teeth near the tip.

Sixth abdominal somite about one and three-fourths times as long as fifth, as in female, but telson is slightly longer than the sixth somite.

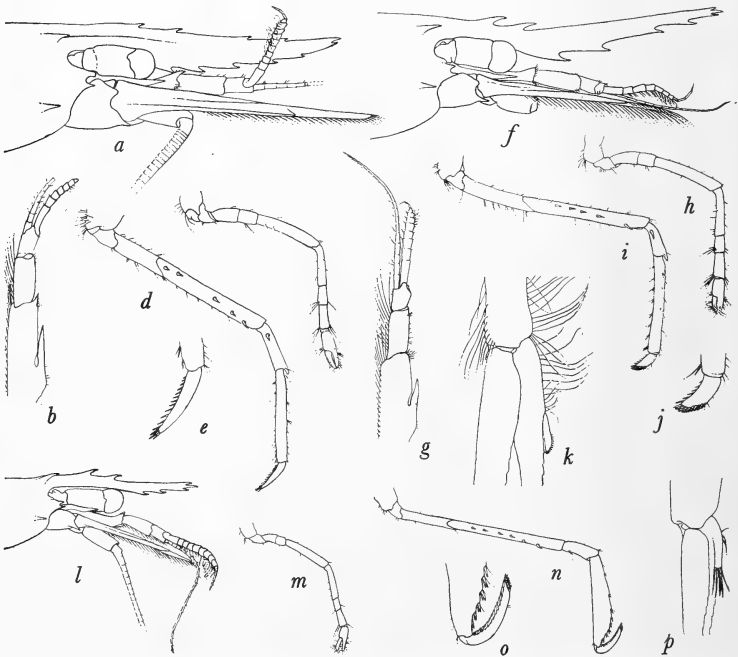

FIG. 1.—a, *Hippolyte californiensis*, frontal part of female from Dillon Beach, Calif.,  $\times 8.3$ ; b, dorsal view of right antennule of female cotype,  $\times 8.3$ ; c, second right leg of same specimen,  $\times 8.3$ ; d, third right leg of same specimen,  $\times 8.3$ ; e, dactyl of same,  $\times 17.4$ ; f, *Hippolyte clarki*, n. sp., frontal part of female holotype,  $\times 8.3$ ; g, dorsal view of right antennule of holotype,  $\times 8.3$ ; h, second right leg of holotype,  $\times 8.3$ ; i, third right leg of holotype,  $\times 8.3$ ; j, dactyl of same,  $\times 17.4$ ; k, anterior view of second right pleopod of holotype,  $\times 17.4$ ; l, frontal part of male paratype from Friday Harbor, Wash.,  $\times 8.3$ ; m, second right leg of same specimen,  $\times 8.3$ ; n, third right leg of same specimen,  $\times 8.3$ ; o, dactyl of same,  $\times 17.4$ ; p, anterior view of second right pleopod of same specimen,  $\times 17.4$ .

Eyes reaching forward about to end of stylocerite. First antennular segment armed with row of three spines on distal margin. Outer antennular flagellum composed of about 16 segments, the proximal 10 of which are inflated.

External maxillipeds reaching beyond tip of antennal scale. Legs proportionately longer than in female; third legs reach well beyond end of antennal scale. Propodi of last three pairs very broad and flat in distal half. Dactyls of these legs armed with about 16 spines on lower margin and two large apical spines, which are followed on the distal end of the upper margin by a row of five spines which become progressively smaller proximally.

*Color*.—Green (Holmes); green with pink margins (Hilton).

*Measurements*.—Carapace lengths of smallest ovigerous female and largest female examined, 4.9 and 6.8 mm, respectively. Carapace lengths of males, 2.7 to 3.8 mm.

*Range*.—West coast of North America from Bodega Bay, Calif., to the Gulf of California.

*Material examined*.—Bodega Bay, Calif.; from University of California; 2 females (1 ovigerous), cotypes (U.S.N.M. no. 18697).

Dillon Beach, Marin County, Calif. (tide flats in eel-grass area); June 8, 1941; G. M. Scheibner; 1 female (U.S.N.M. no. 89716).

Mugu Bay, Ventura County, Calif.; May 31, 1923; E. P. Chace; 5 females (3 ovigerous) (U.S.N.M. no. 89710).

Balboa, Calif. (in eel grass); December 26, 1917; W. A. Hilton; from Pomona College; 2 females (1 ovigerous) (U.S.N.M. no. 50659).

San Diego, Calif.; March 9, 1898; *Albatross*; 5 females (2 ovigerous) (U.S.N.M. no. 23403).

Ensenada, Baja California, Mexico; November 28, 1936; S. A. Glassell; 1 female (U.S.N.M. no. 89678).

Off Cape San Lazaro, Baja California, Mexico (in kelp); March 28, 1936; *Zaca* Expedition; 1 specimen (D.T.R., N.Y.Z.S. no. 361072).

Santa Inez Bay, Baja California, Mexico (in stomach of American eared grebe); April 9, 1936; *Zaca* Expedition; 27 specimens (D.T.R., N.Y.Z.S. nos. 361073, 361077). Same (in stomach of American eared grebe); April 11, 1936; 105 specimens (D.T.R., N.Y.Z.S. nos. 361074, 361078, and M.C.Z. no. 9501). Same; 1 fathom; April 15, 1936; 1 male (holotype of *H. mexicana*, D.T.R., N.Y.Z.S. no. 361076). Same; 3 fathoms; April 15, 1936; 1 female (D.T.R., N.Y.Z.S. no. 361075).

### *Hippolyte clarki*, n. sp.

Figs. 1, f-p

*Hippolyte californiensis* Rathbun, 1904, p. 56 (part).—Schmitt, 1921, p. 48 (part), fig. 26, c; 1924a, p. 165 (part). Not *H. californiensis* Holmes, 1895.

*Female*.—Carapace not inflated. A pair of tufts of plumose setae on cardiac region and another on anterior gastric region. Supraorbital spine not large, reaching forward slightly beyond hind margin of orbit. Antennal spine small, separated by a U-shaped notch from suborbital angle; the latter is blunt, but produced about as far as the antennal spine. Branchiostegal spine prominent and set well back from anterior margin of carapace, the tip falling short of the margin by nearly half the length of the spine.

Rostrum extending well beyond end of antennal scale. Upper margin concave in the proximal third and straight and ascending distally, or concave throughout, and usually armed with two teeth above the eye; occasional specimens are found with one or three teeth on the dorsal margin behind the tip. The tip is usually trifid, a small tooth being placed on each margin just back of the apex; occasionally either the dorsal or ventral subapical tooth may be absent (one specimen examined has two subapical teeth on the upper margin, causing the tip of the rostrum to appear quadridentate). Lower margin with a narrow crest, deepest at about the end of the proximal third, and armed with one to five teeth. Supporting ridge on each lateral face of rostrum blunt, not sharply carinate, although prominent proximally.

Abdomen with a pair of tufts of plumose setae on posterior parts of first and second somites and two pairs of such tufts on third. Third somite produced in a low, blunt cap over anterior part of fourth somite. Fifth somite unarmed. Sixth somite nearly twice as long as fifth. Telson slightly shorter than sixth somite, flattened dorsoventrally, and armed with two pairs of lateral spines, the anterior spine inserted at a point not quite halfway from the base to the tip of the telson, and the posterior one about midway between the first pair and the tip; there are from six to eight terminal spines, of which the submedian pair is the longest.

Cornea of eye wider than stalk, forming a rather bulbous tip to the stalk, and reaching forward about to the end of the stylocerite. Stylocerite sharp, separated from first segment of

antennular peduncle by a narrow emargination. First antennular segment unarmed distally. Second and third segments slender, the second segment fully twice as long as the third. Inner flagellum made up of 16 to 22 segments, the outer one of 8 to 11, of which the first is usually very long and all but the last three or four moderately inflated. Antenna with a lower spine on basis. Scale narrow with subparallel sides, the inner angle of the blade angular and produced far beyond the level of the outer spine.

External maxillipeds rather slender, reaching nearly as far as end of antennal peduncle. There is a fairly well developed exopod. First legs robust, unarmed; carpus distinctly longer than palm. First joint of carpus of second legs nearly three times as long as second, which is slightly shorter than the third; chela a little shorter than the combined lengths of the second and third joints of the carpus. Third leg reaching forward about to end of antennal scale; merus with two to five lateral spines; carpus with one; propodus slender with subparallel sides and armed ventrally with five to seven pairs of spinules increasing in length distally, the inner spine of each pair being much shorter than the outer; dactyl broad and short, armed with six to eight ventral spines and a double row of eight longer ones crowded onto the distal half of the upper margin. Fourth leg extending forward nearly to end of second segment of antennular peduncle; merus armed with up to five lateral spines; carpus with one; propodus and dactyl as in third leg. Fifth leg reaching forward about to end of first antennular segment; merus armed with up to four lateral spines; carpus with one; propodus and dactyl as in third leg.

*Male*.—Rostrum slender, reaching about to end of antennular peduncles, and somewhat up-curved distally. Rostral margins subparallel. Rostral armature roughly as in females (one male examined has no ventral tooth); the tip is often more obscurely trifid than in the female, because either the dorsal or ventral subapical tooth may be placed farther from the tip.

Third segment of abdomen lower than in the female, the cap over the proximal portion of the fourth somite less pronounced.

Eyes reaching forward well beyond end of stylocerite. Outer antennular flagellum composed of 8 to 16 segments, all but the terminal 3 to 5

of which are somewhat more noticeably inflated than in the female.

External maxillipeds reaching well beyond end of antennal peduncle. All of the legs are longer than in the female; third legs overreach antennal scale by length of dactyl and most of propodus. Propodi of last three pairs very broad and flat in distal half, the inflated portion being armed with seven pairs of large spines. Dactyls of these legs elongate, ending in a strong spine, with a row of about 14 spines on lower margin and five or six pairs of close-set spines on distal third of upper margin.

There is but one appendix on the endopod of the second pleopods, but that is strongly setose, unlike the stylambys in the female.

*Age variation*.—In small specimens the rostrum is shorter, reaching just to the tip of the antennal scales in females, and the cornea is no wider than the eyestalk. As in other species of the genus, the younger the specimen, the fewer are the segments in the antennular flagella.

*Measurements*.—Carapace lengths of smallest ovigerous female and largest female examined 3.0 and 6.0 mm, respectively. Carapace lengths of males 1.7 to 3.2 mm.

*Range*.—West coast of North America from Sitka, Alaska, to Puget Sound. A lot of 47 specimens collected by the *Anton Dohrn* is labeled "Southern California," but this locality seems doubtful.

*Material examined*.—Sitka, Alaska; 10 fathoms; June 15, 1899; station 1; Harriman Expedition, W. E. Ritter; 1 female (U.S.N.M. no. 25846).

Barclay Sound, British Columbia; September 27, 1888; *Albatross*; 1 ovigerous female (U.S.N.M. no. 28330).

Nanaimo, British Columbia; C. H. O'Donoghue; 2 males, 1 female (U.S.N.M. no. 54720).

Friday Harbor, Wash.; in eel grass; August 5, 1928; K. L. Hobbs; 1 ovigerous female holotype (U.S.N.M. no. 91089); 18 males, 13 females (7 ovigerous) (U.S.N.M. no. 63089).

Quarantine Rock, Port Townsend, Wash.; June 27, 1903; *Albatross*; 2 males, 1 ovigerous female (U.S.N.M. no. 31866).

Puget Sound; 1895; T. Kincaid; 7 ovigerous females (U.S.N.M. no. 25835).

"Southern California"; *Anton Dohrn*; from Venice Marine Biological Station; 1 male, 46 females (28 ovigerous) (U.S.N.M. no. 50428).



LITERATURE CITED

CHACE, FENNER ALBERT, JR. *The Templeton Crocker Expedition. VII. Caridean decapod Crustacea from the Gulf of California and the west coast of Lower California.* Zoologica **22** (pt. 2): 109-138, 9 figs. 1937.

HOLMES, SAMUEL JACKSON. *Notes on west American Crustacea.* Proc. California Acad. Sci. **4**: 563-588, pls. 20-21. 1895.

RATHBUN, MARY JANE. *Decapod crustaceans of the northwest coast of North America.* Harriman

Alaska Exped. **10**: 1-190, 95 figs., pls. 1-10. 1904.

SCHMITT, WALDO LASALLE. *The marine decapod Crustacea of California.* Univ. California Publ. Zool. **23**: 1-470, 165 figs., pls. 1-50. 1921.

— . *The Macrura and Anomura collected by the Williams Galapagos Expedition, 1923.* Zoologica **5** (15): 161-171, 3 figs. 1924.

— . *Expedition of the California Academy of Sciences to the Gulf of California in 1921. Crustacea (Macrura and Anomura).* Proc. California Acad. Sci. **13** (24): 381-388. 1924.

TABLE 1.—DISTINGUISHING CHARACTERS OF THE WESTERN NORTH AMERICAN SPECIES OF HIPPOLYTE

<i>Hippolyte californiensis</i>		<i>Hippolyte clarki</i>	
Female	Male	Female	Male
<b>ROSTRUM:</b>			
Reaching not quite as far as, or a little beyond, end of antennal scale.	Falling short of end of second segment of antennular peduncle.	Reaching well beyond end of antennal scale in adults.	Reaching about to end of antennular peduncle.
Nearly horizontal or faintly upcurved.	Horizontal or slightly downcurved.	Distinctly upcurved or ascending.	Slightly upcurved distally.
Armed with 3-4 dorsal and 3-5 ventral teeth in back of terminal set, tip usually bifid.	Armed with 2-4 dorsal and 1-3 ventral teeth in back of terminal set, tip usually bifid.	Armed with 1-3 (usually 2) teeth above eye and 1-5 ventral teeth in back of terminal set; tip usually trifid.	Same.
Lateral supporting ridge sharp above eye, becoming blunt distally.	Same.	Lateral supporting ridge blunt throughout its length.	Same.
<b>ABDOMEN:</b>			
Cap on third somite very low.	Same.	Cap on third somite slightly higher and more prominent.	Same.
Sixth somite about 1½ times as long as fifth.	Same.	Sixth somite nearly twice as long as fifth.	Same.
<b>EYE:</b>			
Not reaching forward as far as tip of stylocerite.	Reaching forward about to tip of stylocerite.	Reaching forward about to tip of stylocerite.	Reaching forward nearly to end of first antennular segment.
<b>ANTENNULAR PEDUNCLE:</b>			
First segment armed with 1-2 outer distal spines.	First segment armed with 3 outer distal spines.	First segment unarmed distally.	Same.
<b>SECOND LEG:</b>			
First joint of carpus little more than twice as long as second.	First joint of carpus barely twice as long as second.	First joint of carpus nearly three times as long as second.	Same.
<b>THIRD LEG:</b>			
Reaching forward nearly as far as end of antennular peduncle.	Reaching forward well beyond end of antennal scale.	Reaching forward about to end of antennal scale.	Overreaching antennal scale by length of dactyl and most of propodus.
Dactyl slender, nearly half as long as propodus, and armed with 10-13 ventral and 3 distal spines.	Dactyl moderately slender, about half as long as propodus, and armed with about 16 ventral and 7 distal spines extending onto dorsal margin.	Dactyl very stout, less than a third as long as propodus, and armed with 6-8 ventral and 8-9 distal spines extending nearly to midpoint of dorsal margin.	Dactyl slender, less than half as long as propodus, and armed with about 14 ventral and 5-6 distal spines extending a short distance on dorsal margin.

ZOOLOGY.—*Two new primnoid corals of the subfamily Calyptrophorinae (Coelenterata: Octocorallia).*<sup>1</sup> FREDERICK M. BAYER, U. S. National Museum.

The vast collections of marine animals obtained by the United States Fish Commission steamer *Albatross* are still yielding new species, two of which are described below. Among the octocorals this is not surprising for a considerable part of the collection has not yet been studied. The first species herein described, taken by the *Albatross* during its Hawaiian cruise (1902), was erroneously included with a previously described species in the original report on the Hawaiian Alcyonaria (Nutting, 1908); the other is from the incomparable collection assembled during the Philippine cruise of the *Albatross* (1906-1910). No complete report upon the collections of the latter expedition has yet been made.

It is a great pleasure indeed to dedicate these two species to Austin H. Clark, retiring curator of echinoderms, U. S. National Museum, and his charming wife, Leila Forbes Clark, librarian of the Smithsonian Institution.

#### Genus *Calyptrophora* Gray

*Calyptrophora* J. E. Gray, 1866, p. 25.

*Diagnosis.*—Primnoids with branching dichotomous, in one plane or bushy; or lyrate, in one or two parallel planes; or partly in whorls, partly dichotomous. Zooids arranged in whorls, with their mouths directed upward or downward; body scales reduced to two pairs of large, curved plates which are either fused to form two solid rings, or are separate; adaxial buccal (marginal) scales present or absent; no more than one pair of infrabasal scales between the basal body pair and the rind scales. The operculum is well developed, consisting of eight large scales. The spicules of the stem rind are more or less elongate, flattened scales or plates, in one layer.

*Genotype.*—*Calyptrophora japonica* Gray (by monotypy).

#### *Calyptrophora clarki*, n. sp. Fig. 1

*Calyptrophora japonica* Gray, Nutting, 1908, p. 578 (part).

Not *Calyptrophora japonica* Gray, 1866, p. 25, fig. 1.

<sup>1</sup> Published by permission of the Secretary of the Smithsonian Institution. Received October 6, 1950.

*Diagnosis.*—Branching dichotomous, in one plane. Zooids facing apically; both pairs of body scales fused to form solid rings; basal ring with a pair of long, slender, finely serrate spines; buccal ring with two broad, bladeliike, finely serrate processes, which are occasionally bifid or trifid, sometimes completely divided to form four or six separate processes. A pair of well-defined infrabasal scales is present.

*Description.*—The colony is branched dichotomously, in one plane; the axis is longitudinally grooved and has a golden luster. The zooids (Fig. 1, *D*), which are 2.25-2.50 mm long including the buccal spines (measured parallel to the branch), occur in whorls of four or five (Fig. 1, *A*), and face upward; in 3 cm of branch length there are from 12 to 14 whorls. The zooid body is surrounded by two pairs of large sclerites fused to form rings. The basal ring (Fig. 1, *E*) bears on its free edge a pair of long, slender, finely serrated spines; the buccal ring (Fig. 1, *F*) has two broad, bladeliike processes which are sometimes divided more or less completely into two or three points or separate spines. A pair or narrow, curved infrabasals connects the basal ring with the stem scales. Adaxial buccal (marginal) scales are absent. The operculum is high and projects prominently from the buccal ring. The abaxial operculars are the largest, roughly triangular in shape and with a moderately strong inner keel; the adaxials are about half as large and more nearly perfect triangles; the outer lateral and inner lateral operculars are intermediate in size and more or less asymmetrical in outline due to the broadly rounded inner margin which overlaps the edge of the adaxially adjacent scale. The apical margins of the operculars are usually serrate, and in some zooids are divided into several lobes or low points (Figs. 1, *B*, *C*). The spicules of the stem rind are elongate scales without external ridges.

*Type.*—U.S.N.M. no. 25370.

*Locality.*—Hawaiian Islands: Ukula Point, Kauai Island, bearing north 65° 30', west 7.4 miles, 508-557 fathoms, gray sand and Foraminifera, bottom temperature 40° F., June 17, 1902 (*Albatross* station 4007).

*Paratype.*—U.S.N.M. no. 43139; Hawaiian Islands.

*Remarks.*—In habit, *Calyptrophora clarki* is

readily distinguishable from *C. japonica* Gray by its regularly dichotomous instead of lyrate branching. Most zooids of *C. clarki* are at once separable from those of *C. japonica* by the two broad processes of the buccal ring; there is, however, much variation among individuals, even of the same colony, in the character of the buccal spines, and though there are ordinarily but two broad processes, there may occasionally be four, and sometimes even six. None of the specimens of *C. japonica* I have examined show six buccal spines. Both the buccal and the basal spines of *C. clarki* are proportionally much longer than those of *C. japonica*, except perhaps for Versluys' specimen no. 3 of his "form B" (1906, p. 118, figs. 166-168), which is probably not *C. japonica* at all but something close to the present species.

Genus *Narella* Gray

*Narella* J. E. Gray, 1870, p. 49.  
*Stachyodes* + *Calypterinus* Th. Studer [and E. P. Wright], 1887, p. 49; E. P. Wright and Th. Studer, 1889, pp. xlvi, 53, 54.

*Diagnosis*.—Primnoïds mostly branched dichotomously, in one plane or bushy. Zooids arranged in whorls, with their mouths directed downward; body scales three pairs of large, curved plates, of which the basal pair may meet adaxially to form a closed ring (in one species the buccal pair also); adaxial buccal (marginal) scales are frequently present in one or more pairs. The operculum consists of eight large scales. Spicules of the stem rind variable, elongate or scalelike, in one or two layers.

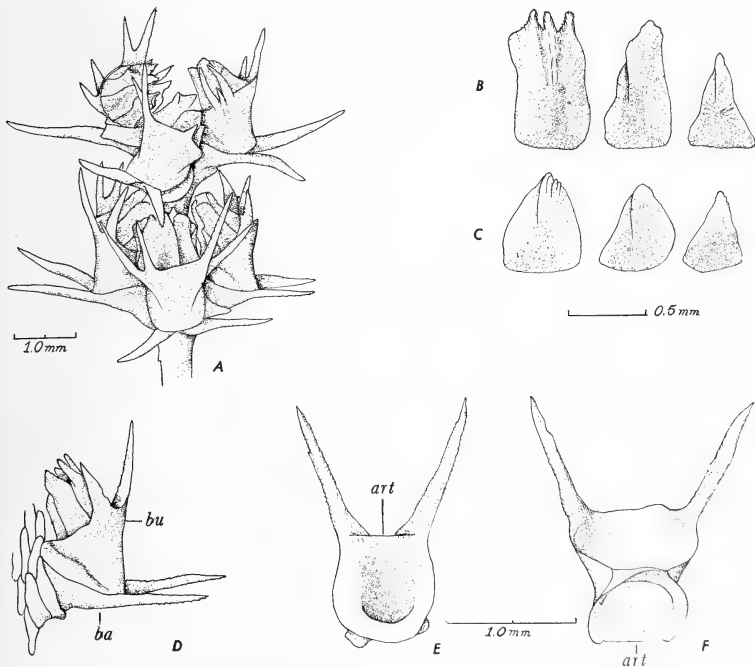

FIG. 1.—*Calyptrophora clarki* n. sp. A, Two distalmost whorls from the type specimen; B, three opercular scales, abaxial, inner lateral and adaxial, of the large, lacinate type; C, the same, of the small type; D, typical zooid, side view; E, basal scale ring; art, articulating ridge; F, buccal scale ring; art, articulating ridge which rides on that of the basal ring.

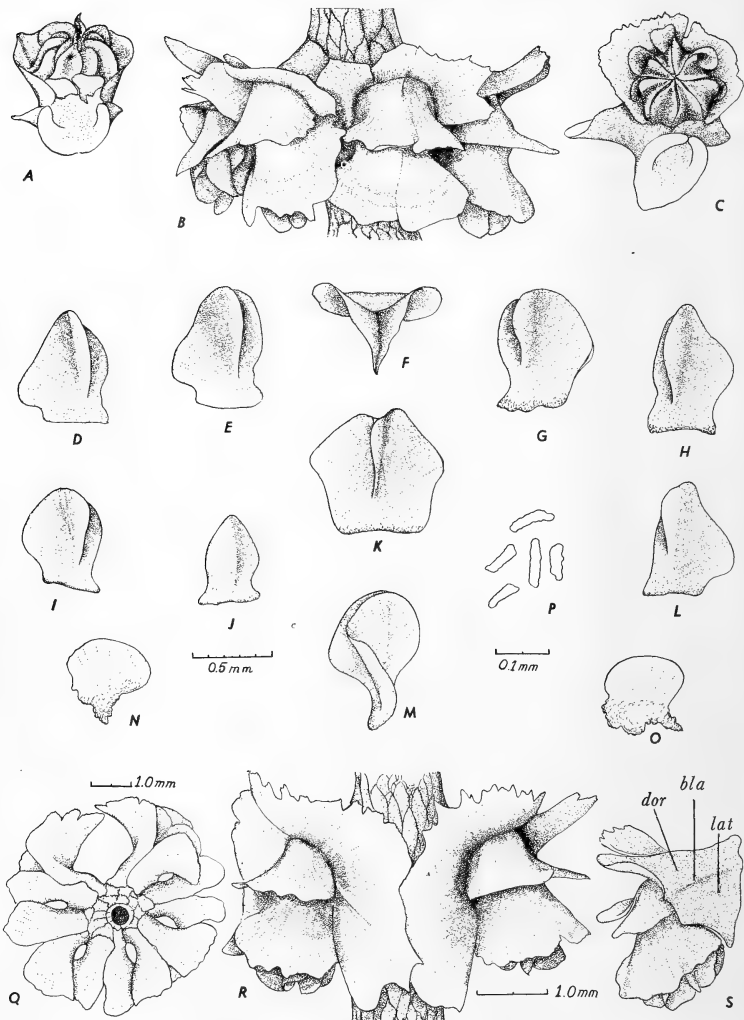

FIG. 2.—*Narella leilae* n. sp.: A, Adaxial view of zooid showing adaxial buccal scales; B, a whorl of normal zooids; C, opercular view of zooid; D-M, opercular scales; F, K, M, apical, inner face, and side view of major abaxial opercular scale; N, O, adaxial buccal scales (scale at J applies to all opercular scales); P, small flattened rods from the tentacles (scale applies only to P); Q, zooid whorl from above, showing worm tunnel (scale applies only to Q); R, zooid whorl from side, showing "arcade polyps" with abnormally expanded basal scales (scale applies to A-C, R, S); S, normal zooid from the side, showing: dor, "dorsal" and lat, lateral regions of basal scale; and bla, the basolateral angle which separates the two.

*Genotype*.—*Primnoa regularis* Duchassaing and Michelotti, 1860 (by monotypy).

*Remarks*.—As Miss Deichmann (1936, p. 168) points out, *Narella* clearly has priority over *Stachyodes*. The genus *Calypterinus* was established for a specimen with abnormal polyps due to a polychaete commensal. Calyptrophorines, especially *Narella*, are frequently infested with worms which cause adjacent polyps along one side of the stem to form greatly expanded basal scales which produce a sort of arcade in which the worm makes its home (Fig. 2, *Q, R*).

*Narella leilae*, n. sp. Fig. 2

*Diagnosis*.—Branching lateral-dichotomous, in one plane. Zooids small, 2.0–2.5 mm long, facing basally; only basal scale pair meeting adaxially to form a ring; free margins of all three body-scale pairs broadly expanded but not forming long, projecting points; free lateral border of each basal scale with a downward and forward projecting angle; basal scale distinctly divided into dorsal and lateral regions by a basolateral angle. Operculum low, the individual scales broad, with a high inner keel.

*Description*.—The type consists of three fragments, the largest of which is about 70 mm tall and twice branched dichotomously. In the proximal part the axis is a little flattened in the plane of branching, oval in the lowest part of the type specimen, becoming almost round in the distal-most tips; it is longitudinally grooved, and of a brownish-yellow color with moderate luster. The downward facing zooids (Fig. 2, *S*) are 2.0–2.5 mm long (measured parallel to the branch), arranged in whorls of four to six (Fig. 2, *B*), of which 10–12 occur in 3 cm of axial length. The zooid body is surrounded by three pairs of large scales, of which only the basal pair meet adaxially to form a ring; the free edges of all three pairs are broadly expanded, those of the basal and medial pairs more or less reflexed while that of the buccals is curved a little inward; basals bent along a definite basolateral angle which divides the scale into dorsal and lateral regions; the free lateral edge of the basal scale has a forward and downward projecting angle (Fig. 2, *S*). The operculum is very low; the scales are broad, the largest abaxial almost pentagonal in face view (Fig. 2, *K*), and each is furnished with a very high keel on the inner face and corresponding groove on the outer (Fig. 2, *D–M*). One pair of adaxial buccals is present (Fig. 2, *A, N, O*). The tentacles contain very small (0.04–0.07 mm) flat rods (Fig. 2, *P*).

The coenenchyma scales are irregular, rather elongate plates, those nearest to zooids often with a high, thin longitudinal crest.

*Type*.—U.S.N.M. no. 49724.

*Locality*.—Off Kapoposang Light, Straits of Macassar, lat. 4° 43' 22" S., long. 118° 53' 18" E., 400 fathoms, hard bottom, bottom temperature 43.3° F., December 28, 1909 (*Albatross* station 5664).

*Additional record*.—Off Gomomo Island, Pitt Passage, lat. 1° 53' 30" S., long. 127° 39' 00" E., 400 fathoms, coral, rock, soapstone, (no temperature data), December 3, 1909 (*Albatross* station 5635).

*Remarks*.—*Narella leilae*, n. sp., shows a certain resemblance to *N. clavata* (Versluys) in its closed basal scale pair and definite basolateral angles; the development of abnormal "arcade polyps" (Fig. 2, *Q, R*) induced by polychaete commensals is similar to that of *Narella allmani* (Wright and Studer). *Narella leilae* differs from *N. clavata* in its smaller zooids and exceptionally low operculum, its thinner and more delicate body scales, and in absence of a high dorsal crest on the basals; from *N. allmani* it differs in having adaxially closed basal scales, the buccals not being drawn out into projecting points, and in the much broader opercular scales.

#### LITERATURE CITED

- DEICHMANN, ELISABETH. *The Alcyonaria of the western part of the Atlantic Ocean*. Mem. Mus. Comp. Zool. **53**: 1–317, pls. 1–37. 1936.
- DUCHASSAING DE FONBRESSIN, P., and MICHELLOTTI, J. *Memoire sur les coralliaires des Antilles*. Mem. Accad. Sci. Torino (2) **19**: 279–365, pls. 1–10. 1860.
- GRAY, JOHN EDWARD. *Description of two new forms of gorgonoid corals*. Proc. Zool. Soc. London **1866**: 24–27, figs 1–2. 1866.
- . *Catalogue of lithophytes or stony corals in the collection of the British Museum*. 2 lvs. + 1–51, figs. 1–14. 1870.
- NUTTING, CHARLES CLEVELAND. *Descriptions of the Alcyonaria collected by the U. S. Bureau of Fisheries steamer Albatross in the vicinity of the Hawaiian Islands in 1902*. Proc. U. S. Nat. Mus. **34**: 543–601, pls. 41–51. 1908.
- STUDER, THÉOPHILE [and WRIGHT, EDWARD PERCEVAL]. *Versuch eines Systemes der Alcyonaria*. Arch. für Naturg. **53** Jahrg. (1): 1–74, pl. 1. 1887.
- VERSLUYS, J. *Die Gorgoniden der Siboga Expedition. II. Die Primnoidae*. Siboga Exped. **13a**: 1–187, 178 figs., pls. 1–10, chart. 1906.
- WRIGHT, EDWARD PERCEVAL, and STUDER, THÉOPHILE. *Report on the Alcyonaria collected by H.M.S. Challenger during the years 1873–1876*. Challenger Reports, Zool., **31**: i–lxxi + 1–314, pls. 1–43. 1889.

ZOOLOGY.—*A new species of polychaete worm of the family Polynoidae from Point Barrow, Alaska.*<sup>1</sup> MARIAN H. PETTIBONE, Arctic Research Laboratory, Johns Hopkins University. (Communicated by Fenner A. Chace, Jr.)

The new species of Polynoidae herein described is part of a collection of polychaetes from Point Barrow, Alaska, collected by George E. MacGinitie, of the Arctic Research Laboratory. The types are deposited in the United States National Museum. I take pleasure in naming it after Austin H. Clark, retiring curator of echinoderms, United States National Museum.

Family POLYNOIDAE

Genus *Eunoë* Malmgren, 1865

*Eunoë clarki*, n. sp.

Fig. 1, *a-e*

*Measurements*.—The type (U.S.N.M. no. 21984), of 41 segments, is 38 mm long, 8 mm wide excluding setae, and 12 mm wide including setae. The paratype (U.S.N.M. no. 21985), of 40 segments, is 36 mm long and is of the same width as the type.

*Description*.—The body is linear-oblong, widest in segments 9 to 27, narrowing slightly anteriorly and slightly more so posteriorly; it is oval in cross section. The middorsum is transversely banded with grayish green; the ventral surface is without color except for the grayish-green coloration anterior and lateral to the mouth. Fifteen pairs of elytra nearly cover the dorsum; they are large, imbricated, arranged on segments 2, 4, 5, 7, 9 . . . 23, 26, 29, and 32. The elytra (Fig. 1, *a*) are oval to subreniform in shape, greenish gray in color, with a darker mottled pattern on most of the exposed parts of the elytra, and with a darker spot medial to a lighter area over the elytophore—giving the appearance of paired "ocelli" (similar in this regard to *Halosydna brevisetosa* Kinberg). The elytral border is smooth except for scattered clavate micropapillae (Fig. 1, *e*). The elytral surface, although appearing smooth, is furnished with numerous chitinous bluntly conical micro-tubercles (up to 30 $\mu$  in height, Fig. 1, *e*).

The prostomium (Fig. 1, *a*) is bilobed, wider than long, somewhat pigmented, with a deep anteromedian notch; cephalic peaks are lacking. The four eyes are small, the posterior pair situated dorsal and slightly posterior to the widest part of

the prostomium, the anterior pair are anterolateral. The median antenna has a large pigmented ceratophore; the style is about 1.5 times the length of the prostomium, with a pigmented proximal part, and with very short scattered clavate papillae. The lateral antennae are inserted ventral to the median antenna on the prostomium; the ceratophores are short, darkly pigmented; the styles are short—about half the length of the median antenna—and furnished with short papillae. The palpi are about 2.5 times the length of the prostomium, with longitudinal rows of fine papillae.

The tentacular segment (Fig. 1, *a*) has the basal lobes elongated, pigmented on the basal half, with one seta; the tentacular cirri are longer than the median antenna, about 2.5 times the length of the prostomium, with a wide pigmented zone basally and a narrow darker pigmented ring below the subterminal slightly bulbous enlargement, with a filamentous tip, and with short scattered clavate papillae. The dorsal cirri (Fig. 1, *a*) have elongated cirrophores, bulbous basally and narrower distally; the styles are similar to the tentacular cirri, with or without the basal pigmented zone, and extend beyond the tips of the setae. The dorsal tubercles, corresponding to the elytophores on the cirrus-bearing segments, are short and bulbous. The ventral cirri are subulate, enlarged basally, tapering distally to filamentous tips (Fig. 1, *b*). The anal cirri are missing. The segmental or nephridial papillae begin on segment 6 and continue posteriorly; they are rather long and cylindrical, especially in the segments of the middle third of the body.

The parapodia (Fig. 1, *b*) are biramous. The notopodium is a rounded lobe on the anterodorsal face of the neuropodium, extending out into a narrower acicular lobe from which the aciculum projects. The notosetae (Fig. 1, *b, c*) are amber-colored, moderate in number (about 40), forming a spreading bundle; they are slightly arched, slender to stout (20–80 $\mu$  in greatest diameter), with long spinous regions extending over half of the exposed length, and short bare pointed to blunt tips. The neuropodium is obliquely truncate distally, with a longer dorsoanterior acicular lobe. The neurosetae (Fig. 1, *b, d*) are amber-colored, moderate in size (30–50 $\mu$  in diameter in the stem

<sup>1</sup> This study was aided by a contract between the Office of Naval Research, Department of the Navy, and Johns Hopkins University. Received October 6, 1950.

region, 36–62 $\mu$  in greatest diameter in the enlarged distal region), with transverse spinous rows (9–24 or so rows), and rather long bare entire tips.

*Remarks.*—*Eunoë clarki* resembles in superficial appearance *Halosydna brevisetosa* Kinberg—the common Pacific coast polynoid—particularly in its linear shape and mottled elytral pigmentation with paired “ocelli.” It differs from *Eunoë nodosa* (Sars) and *Eunoë oerstedii* Malmgren in lacking macrotubercles and fringes of papillae on the

elytra, in the smaller eyes, and in the location of the anterior pair of eyes—anterolateral and not anterodorsal. It might well prove to be commensal in habit, as shown by the small eyes, absence of elytral macrotubercles, and elytral fringes of papillae.

*Locality.*—Two specimens were collected at Point Barrow base, Alaska, by George E. MacGinitie, October 17, 1949. They were washed ashore after a storm along with many other animals, including numerous polychaetes.

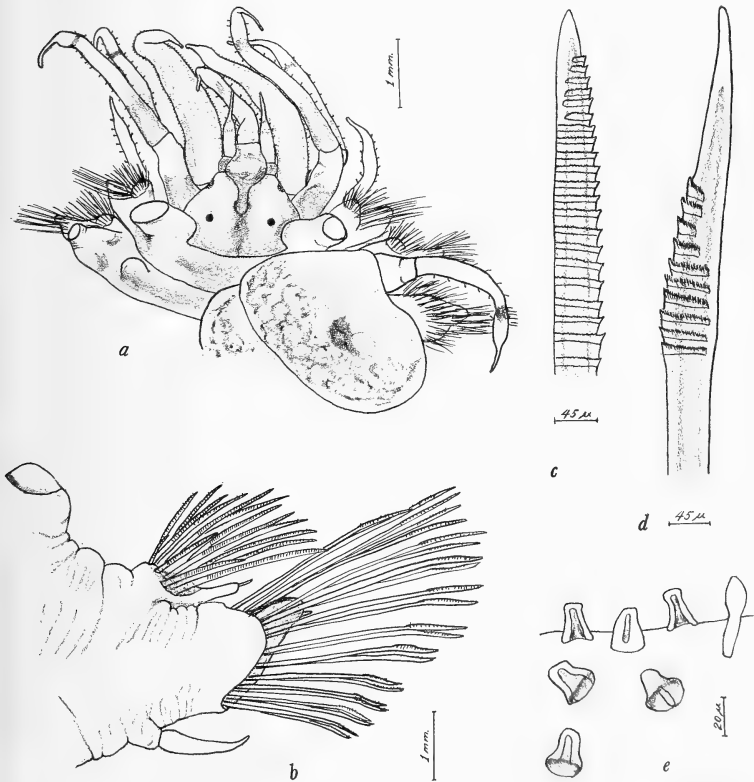

FIG. 1.—*Eunoë clarki*, n. sp.: a, Dorsal view prostomium, first three segments, and second right elytron and parapodium of fourth segment (first elytral pair and second left elytron removed); b, third right parapodium, posterior view; c, tip of notoseta; d, tip of middle subacicular neuroseta; e, few microtubercles and papilla from eighth elytron.

ENTOMOLOGY.—*A new genus and species of North American Olethreutidae (Lepidoptera: Laspeyresiinae).*<sup>1</sup> J. F. GATES CLARKE, Bureau of Entomology and Plant Quarantine.

The new species of olethreutid moth described herein, which becomes the type of a new genus, I take pleasure in naming for my friend Austin H. Clark, retiring curator of echinoderms of the United States National Museum, who, among his other accomplishments, is a lepidopterist of long-standing and world-wide repute.

*Corticivora*, n. gen.

Figs. 1-1e

*Typus generis*.—*Corticivora clarki*, n. sp.

Head rough; labial palpus not exceeding front, third segment about one-fifth the length of second. Thorax without posterior tuft.

Forewing smooth; termen nearly straight; 12 veins, all separate; vein 2 remote from 3; 3, 4, and 5 approximate at bases; 8 and 9 approximate basally; 11 from before middle; upper internal vein of cell from between 10 and 11, very weakly developed. Costal fold absent.

Hindwing with normal pecten on lower median vein; 8 veins; 3 and 4 stalked; 6 and 7 stalked; termen slightly concave.

Male genitalia with cucullus narrow and sacculus broad without spine clusters; socii well-developed, fleshy, haired pads; uncus absent.

Female genitalia with signa developed as scobinate-dentate cones.

Structurally *Corticivora* is similar to *Gypsonoma* (Eucosminae) though remaining clearly laspeyresiine. As in *Gypsonoma* all veins of the forewing are separate in *Corticivora* and in the hindwing 3 and 4 and 6 and 7 are stalked. The upper internal vein of *Gypsonoma* arises between 9 and 10 and that of *Corticivora* between 10 and 11. In the hindwing vein 5 of *Gypsonoma* is approximate to 4, whereas that of *Corticivora* is remote from 4.

In both genera the socii are present, a character seldom found in the Laspeyresiinae.

*Corticivora* appears to be most nearly related to

*Laspeyresia* but differs from it by the stalking of veins 6 and 7 of the hindwing, the presence of socii, and the form of the signa.

*Corticivora clarki*, n. sp.

Alar expanse, 10-11 mm.

Labial palpus sordid whitish; second segment suffused and sparsely irrorate with gray; second segment almost wholly gray externally, except apex. Antenna dark grayish fuscous with narrow, paler annulations. Head creamy white. Thorax grayish fuscous. Ground color of forewing cinereous, the scales narrowly white-tipped; basal patch and other dark markings grayish fuscous as illustrated; narrow subbasal line of cilia black, cilia leaden. Hindwing light grayish fuscous; cilia, except subbasal band, paler. Legs creamy white suffused and banded with grayish fuscous. Abdomen grayish fuscous above, creamy white beneath.

*Male genitalia*.—As figured. Cucullus with strong, long setae along ventral edge; aedeagus broad and flattened dorsally and distal two-thirds abruptly narrowed, cylindrical, pointed.

*Female genitalia*.—As figured. Signa conical, studded with sharp scobinate-dentate processes; posterior portion of ductus bursae lightly sclerotized, slender.

*Type*.—U.S.N.M. no. 60582.

*Type locality*.—North Guilford, Conn.

*Food plant*.—Red pine (*Pinus resinosa* Ait.).

*Remarks*.—Described from the type male and four male and three female paratypes from the type locality, all reared by G. H. Plumb and J. V. Schaffner. Emergence dates range from June 24 to July 2, 1944. Paratypes in the U. S. National Museum and British Museum (Natural History).

G. H. Plumb, who submitted the above material for identification, will publish the life history of this interesting species.

The photographs for the accompanying figures were taken by Floyd B. Kestner, photographer of the Smithsonian Institution.

<sup>1</sup> Received October 6, 1950.



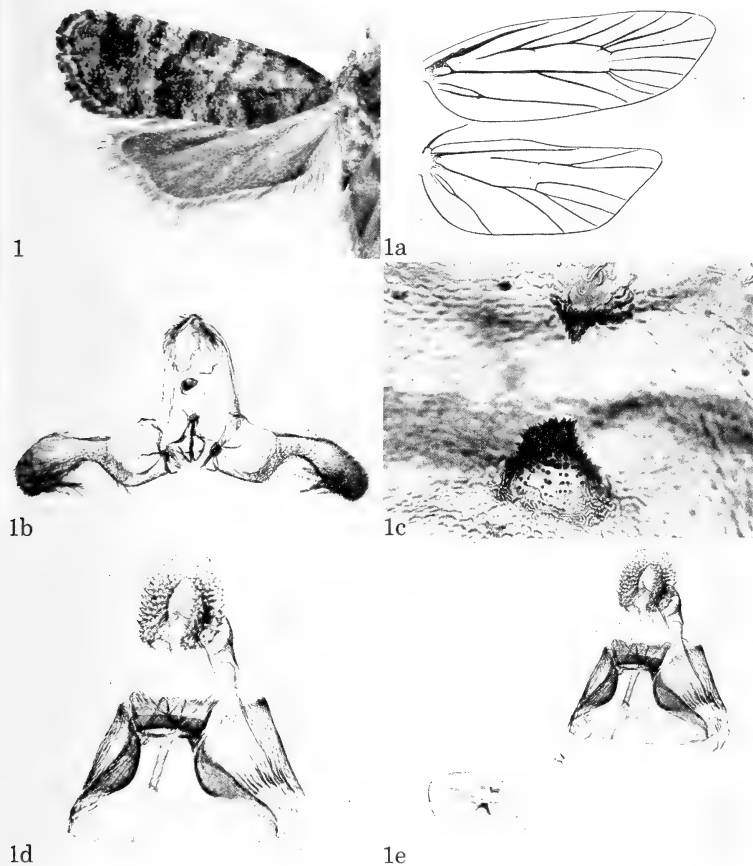

FIGS. 1-1e.—*Corticivora clarki*, n. sp.: 1, Left wings; 1a, venation of right wings; 1b, ventral view of male genitalia with aedeagus in situ; 1c, enlarged view of signa; 1d, detail of genital plate and ostium; 1e, ventral view of female genitalia.

## PROCEEDINGS OF THE ACADEMY

## 411ST MEETING OF BOARD OF MANAGERS

The 411st meeting of the Board of Managers, held in the Cosmos Club on November 20, 1950, was called to order at 8:03 p. m. by the President, F. B. SILSBEE. Also present were: N. R. SMITH, W. N. FENTON, C. L. GAZIN, A. T. MCPHERSON, W. A. DAYTON, H. W. HEMPLE, MARGARET PITTMAN, F. M. SETZLER, and, by invitation, L. W. PARR.

The President announced the appointment of the following Subcommittee for the Teaching of Science of the Committee on Awards for Scientific Achievement for 1950: B. D. VAN EVERA, chairman, R. P. BARNES, F. E. FOX, T. KOPPANYI, M. H. MARTIN, A. T. MCPHERSON.

Twenty-six persons were elected to membership in the Academy.

The following report of the Nominating Committee was presented:

The Nominating Committee, consisting of the Academy's Vice-presidents, met in the library of the Cosmos Club on November 6, 1950. The meeting was called to order at 5 p. m. by F. C. KRACEK, who presided. Others present were: C. F. W. MUESEBECK, J. S. WILLIAMS, W. A. DAYTON, F. M. DEFANDORF, E. W. PRICE, MARGARET PITTMAN, H. W. HEMPLE, and H. G. DORSEY. F. M. SETZLER acted as secretary but took no part in the balloting.

The nominees selected for the offices to be filled by the balloting of the membership in December were as follows: For *President-elect*, WALTER RAMBERG; for *Secretary*, FRANCIS M. DEFANDORF; for *Treasurer*, HOWARD S. RAPPLEYE; for *Board of Managers* to serve 3 years (two to be elected), SARA E. BRANHAM, MILTON HARRIS, C. F. W. MUESEBECK, JOHN A. STEVENSON.

The Secretary reported the death on June 18, 1950, of FRANK W. SCHWAB, of the National Bureau of Standards (elected October 15, 1945).

The meeting adjourned at 8:40 p. m.

## 442D MEETING OF BOARD OF MANAGERS

The 442d meeting of the Board of Managers, held in the Cosmos Club on December 18, 1950, was called to order by the President, F. B.

SILSBEE, at 8:02 p. m. Also present were: N. R. SMITH, H. S. RAPPLEYE, J. A. STEVENSON, F. M. DEFANDORF, W. R. WEDEL, W. A. DAYTON, C. A. BETTS, E. W. PRICE, MARGARET PITTMAN, F. M. SETZLER, and, by invitation, R. G. BATES.

The President announced the plans for the Encouragement of Science Talent and the Science Fair, indicating that he had requested the customary contributions from the various Affiliated Societies for the support of these activities.

The Chairman of the Committee on Meetings, F. M. DEFANDORF, announced that there would be no regular meeting of the Academy in December. He reported, however, that he had arranged for Dr. PER K. FROLICH, former director of research and now vice-president of Merck & Co., to serve as guest speaker at the annual meeting and dinner of the Academy to be held at the Kennedy-Warren on January 18, 1951.

The Chairman of the Committee on Membership, R. G. BATES, presented the names of 14 resident and 3 nonresident candidates for membership in the Academy. One nonresident candidate previously presented was elected. Two members, HOWARD P. BARSS and VICTOR BIRCKNER, were placed on the retired list, effective December 31, 1950.

The Treasurer, H. S. RAPPLEYE, reported on purchases of office furniture that had been made for the Treasurer's office and requested that an increased allotment of \$25 be made to the budget of the Treasurer. The request was unanimously approved.

The Archivist, J. A. STEVENSON, reported that he and former Archivist, N. A. SMITH, had made a final reorganization of all records of the Academy in the office of the Archivist and that he had prepared a detailed inventory of this material to be presented as his report at the annual meeting of the Academy in January.

Mr. STEVENSON also gave an interesting report on the Seventh International Botanical Congress, held in Stockholm, Sweden, July 12-20, 1950, at which he represented the Academy as delegate.

The meeting adjourned at 8:55 p. m.

FRANK M. SETZLER, *Secretary*.

\* \* \*

## NOTE

Those whose pleasant task it was to bring together the contents of this number of the JOURNAL of the Washington Academy of Sciences, honoring Austin H. Clark, have endeavored to reflect Mr. Clark's wide interest in the natural sciences, although they did not attempt to include papers in all fields in which he has specialized. Mr. Clark's own paper, on "The Brittle-stars of the United States Navy Antarctic Expedition 1947-48," which he submitted to the editors of the JOURNAL last September, was included in this issue without, of course, the author's knowledge. It seems not unfitting, however, that this example of Mr. Clark's work should appear here in an array of scientific papers by those who seek to do him honor.

## Officers of the Washington Academy of Sciences

*President*..... FRANCIS B. SILSBEE, National Bureau of Standards  
*President-elect*..... NATHAN R. SMITH, Plant Industry Station  
*Secretary*..... FRANK M. SETZLER, U. S. National Museum  
*Treasurer*..... HOWARD S. RAPPLEYE, U. S. Coast and Geodetic Survey  
*Archivist*..... JOHN A. STEVENSON, Plant Industry Station  
*Custodian and Subscription Manager of Publications*  
 HARALD A. REHDER, U. S. National Museum

### *Vice-presidents Representing the Affiliated Societies:*

Philosophical Society of Washington..... FRANK C. KRACEK  
 Anthropological Society of Washington..... WALDO R. WEDEL  
 Biological Society of Washington.....  
 Chemical Society of Washington..... JAMES I. HOFFMAN  
 Entomological Society of Washington..... C. F. W. MUESEBECK  
 National Geographic Society..... ALEXANDER WETMORE  
 Geological Society of Washington..... JAMES STEELE WILLIAMS  
 Medical Society of the District of Columbia..... FREDERICK O. COE  
 Columbia Historical Society..... GILBERT GROSVENOR  
 Botanical Society of Washington..... FREEMAN A. WEISS  
 Washington Section, Society of American Foresters..... WILLIAM A. DAYTON  
 Washington Society of Engineers..... CLIFFORD A. BETTS  
 Washington Section, American Institute of Electrical Engineers  
 FRANCIS M. DEFANDORF  
 Washington Section, American Society of Mechanical Engineers..... RICHARD S. DILL  
 Helminthological Society of Washington..... EMMETT W. PRICE  
 Washington Branch, Society of American Bacteriologists..... MARGARET PITTMAN  
 Washington Post, Society of American Military Engineers..... HENRY W. HEMPLE  
 Washington Section, Institute of Radio Engineers..... HERBERT G. DORSEY  
 District of Columbia Section, American Society of Civil Engineers  
 OWEN B. FRENCH

### *Elected Members of the Board of Managers:*

To January 1951..... FRANCIS M. DEFANDORF, WILLIAM N. FENTON  
 To January 1952..... WILLIAM F. FOSHAG, C. LEWIS GAZIN  
 To January 1953..... HOWARD P. BARSS, A. T. MCPHERSON

*Board of Managers*..... All the above officers plus the Senior Editor

*Board of Editors and Associate Editors*..... (See front cover)

*Executive Committee*..... FRANCIS B. SILSBEE (chairman), NATHAN R. SMITH,  
 WILLIAM N. FENTON, HOWARD S. RAPPLEYE, FRANK M. SETZLER

*Committee on Membership*..... ROGER G. BATES (chairman), MERRILL BERNARD,  
 CLIFFORD A. BETTS, WILBUR BURBANK, ROBERT C. DUNCAN, REGINA FLANNERY,  
 A. B. GURNEY, E. H. KENNARD, C. L. LEFEBVRE, C. W. REES, DONALD C. SMITH,  
 L. A. SPINDLER

*Committee on Meetings*..... FRANCIS M. DEFANDORF (chairman), FREDERICK O. COE,  
 MILTON HARRIS, LLOYD G. HENBEST, BYRON J. OLSON, FRANK B. SCHEETZ

### *Committee on Monographs:*

To January 1951..... EMMETT W. PRICE (chairman), WILLIAM N. FENTON  
 To January 1952..... PAUL H. OEHSE, JASON R. SWALLEN  
 To January 1953..... RALPH W. IMLAY, PAUL W. OMAN

### *Committee on Awards for Scientific Achievement (T. DALE STEWART, general chairman):*

For the Biological Sciences..... T. DALE STEWART (chairman),  
 ELOISE B. CRAM, AUREL O. FOSTER, ELBERT L. LITTLE, JR., HAROLD  
 H. MCKINNEY, JOSEPH S. WADE  
 For the Engineering Sciences..... WALTER RAMBERG (chairman),  
 LOUIS W. CURRIER, ROBERT C. DUNCAN, OLIVER S. READING, HARRY W. WELLS  
 For the Physical Sciences..... ROBERT D. HUNTOON (chairman),  
 WILLIAM BLUM, MICHAEL GOLDBERG, RAYMOND J. SEEGER, ERNEST H. VESTINE

### *Committee on Grants-in-aid for Research:*

J. LEON SHERESHEFSKY (chairman), CORNELIUS J. CONNOLLY, L. EDWIN YOCUM

### *Committee on Policy and Planning:*

To January 1951..... LELAND W. PARR (chairman), AUSTIN H. CLARK  
 To January 1952..... JAMES I. HOFFMAN, MARTIN A. MASON  
 To January 1953..... WILLIAM A. DAYTON, NATHAN R. SMITH

### *Committee on Encouragement of Science Talent:*

To January 1951..... B. D. VAN EVERA, JOSEPH M. CALDWELL  
 To January 1952..... MARTIN A. MASON (chairman), A. T. MCPHERSON  
 To January 1953..... AUSTIN H. CLARK, FRED L. MOHLER

*Representative on Council of A. A. A. S.*..... FRANK M. SETZLER

*Committee of Auditors*..... WALTER D. SUTCLIFFE (chairman),  
 C. LEWIS GAZIN, RAYMOND L. SANFORD

*Committee of Tellers*..... FENNER A. CHACE, JR. (chairman), HAROLD F. STIMSON,  
 EGBERT H. WALKER

## CONTENTS

	Page
<i>Dedication.</i> —HERBERT FRIEDMANN.....	1
<i>Portrait of Austin Hobart Clark</i> .....	2
<i>Biographical Résumé.</i> —WALDO L. SCHMITT.....	3
* * *	
PALEONTOLOGY.—New brachiopods from the Lower Cambrian of Virginia. G. ARTHUR COOPER.....	4
PALEONTOLOGY.—Two new guide fossils from the Tallahatta formation of the Southeastern States. JULIA GARDNER.....	8
PALEONTOLOGY.— <i>Nucula austinclarki</i> , n. sp., a concentrically sculptured <i>Nucula</i> from the Lisbon formation of Alabama. F. STEARNS MAC- NEIL.....	12
MALACOLOGY.—New stenothyrid gastropods from the Philippines (Risso- idae). R. TUCKER ABBOTT.....	14
MALACOLOGY.—Two new Western Atlantic species of pulmonate mollusks of the genus <i>Detracia</i> and two old ones (family Ellobiidae). J. P. E. MORRISON.....	17
MALACOLOGY.—A new species of glycymerid from the Philippines. DAVID NICOL.....	20
MALACOLOGY.—Two new Recent cone shells from the Western Atlantic (Conidae). HARALD A. REHDER and R. TUCKER ABBOTT.....	22
MALACOLOGY.—A new scaphopod mollusk, <i>Cadulus austinclarki</i> , from the Gulf of California. WILLIAM K. EMERSON.....	24
ZOOLOGY.—The brittle-stars of the United States Navy Antarctic Expe- dition 1947-48. AUSTIN H. CLARK.....	26
ZOOLOGY.—A new genus and species of notodelphyoid copepod from Japan. PAUL L. ILLG.....	30
ZOOLOGY.—The grass shrimps of the genus <i>Hippolyte</i> from the west coast of North America. FENNER A. CHACE, JR.....	35
ZOOLOGY.—Two new primnoid corals of the subfamily Calyptrophorinae (Coelenterata: Octocorallia). FREDERICK M. BAYER.....	40
ZOOLOGY.—A new species of polychaete worm of the family Polynoidae from Point Barrow, Alaska. MARIAN H. PETTIBONE.....	44
ENTOMOLOGY.—A new genus and species of North American Olethreut- idae (Lepidoptera: Laspeyresiinae). J. F. GATES CLARKE.....	46
PROCEEDINGS: THE ACADEMY.....	48

30.73  
REV 23  
VOL. 41

FEBRUARY 1951

No. 2

# JOURNAL

OF THE

# WASHINGTON ACADEMY OF SCIENCES

## BOARD OF EDITORS

CHARLES DRECHSLER  
PLANT INDUSTRY STATION  
BELTSVILLE, MD.

WILLIAM F. FOSHAG  
U. S. NATIONAL MUSEUM

J. P. E. MORRISON  
U. S. NATIONAL MUSEUM

## ASSOCIATE EDITORS

J. C. EWERS  
ANTHROPOLOGY

C. W. SABROSKY  
ENTOMOLOGY

F. A. CHACE, JR.  
BIOLOGY

J. I. HOFFMAN  
CHEMISTRY

T. P. THAYER  
GEOLOGY

MIRIAM L. BOMHARD  
BOTANY

R. K. COOK  
PHYSICS AND MATHEMATICS

PUBLISHED MONTHLY  
BY THE

WASHINGTON ACADEMY OF SCIENCES  
MOUNT ROYAL & GUILFORD AVES.  
BALTIMORE, MARYLAND

MAR 2 - 1951  
National

Entered as second class matter under the Act of August 24, 1912, at Baltimore, Md.  
Acceptance for mailing at a special rate of postage provided for in the Act of February 28, 1925  
Authorized February 17, 1949

## Journal of the Washington Academy of Sciences

This JOURNAL, the official organ of the Washington Academy of Sciences, publishes: (1) Short original papers, written or communicated by members of the Academy; (2) proceedings and programs of meetings of the Academy and affiliated societies; (3) notes of events connected with the scientific life of Washington. The JOURNAL is issued monthly. Volumes correspond to calendar years.

*Manuscripts* may be sent to any member of the Board of Editors. It is urgently requested that contributors consult the latest numbers of the JOURNAL and conform their manuscripts to the usage found there as regards arrangement of title, subheads, synonymies, footnotes, tables, bibliography, legends for illustrations, and other matter. Manuscripts should be typewritten, double-spaced, on good paper. Footnotes should be numbered serially in pencil and submitted on a separate sheet. The editors do not assume responsibility for the ideas expressed by the author, nor can they undertake to correct other than obvious minor errors.

*Illustrations* in excess of the equivalent (in cost) of one full-page halftone are to be paid for by the author.

*Proof*.—In order to facilitate prompt publication one proof will generally be sent to authors in or near Washington. It is urged that manuscript be submitted in final form; the editors will exercise due care in seeing that copy is followed.

*Unusual cost* of foreign, mathematical, and tabular material, as well as alterations made in the proof by the author, may be charged to the author.

*Author's Reprints*.—Reprints will be furnished in accordance with the following schedule of prices (approximate):

Copies	4 pp.	8 pp.	12 pp.	16 pp.	20 pp.	Covers
100	\$3.25	\$6.50	\$ 9.75	\$13.00	\$16.25	\$3.00
200	6.50	13.00	19.50	26.00	32.50	6.00
300	9.75	19.50	29.25	39.00	48.75	9.00
400	13.00	26.00	39.00	52.00	65.00	12.00

*Subscriptions* or requests for the purchase of back numbers or volumes of the JOURNAL or the PROCEEDINGS should be sent to HARALD A. REHDER, Custodian and Subscription Manager of Publications, U. S. National Museum, Washington 25, D. C.

*Subscription Rates* for the JOURNAL.—Per year..... \$7.50

Price of back numbers and volumes:	Per Vol.	Per Number
Vol. 1 to vol. 10, incl.—not available.*.....	—	—
Vol. 11 to vol. 15, incl. (21 numbers per vol.).....	\$10.00	\$0.70
Vol. 16 to vol. 22, incl. (21 numbers per vol.).....	8.00	0.60
Vol. 23 to current vol. (12 numbers per vol.).....	7.50	0.90

\* Limited number of complete sets of the JOURNAL (vol. 1 to vol. 40, incl.) available for sale to libraries at \$341.00

MONOGRAPH No. 1, "The Parasitic Cuckoos of Africa," by Herbert Friedmann. \$4.50

PROCEEDINGS, vols. 1-13 (1899-1911) complete.....	\$25.00
Single volumes, unbound.....	2.00
Single numbers.....	.25

*Missing Numbers* will be replaced without charge provided that claim is made to the Treasurer within 30 days after date of following issue.

*Remittances* should be made payable to "Washington Academy of Sciences" and addressed to the Treasurer, H. S. RAPPLEYE, 6712 Fourth Street, N.W., Washington 11, D.C.

*Exchanges*.—The Academy does not exchange its publications for those of other societies.

# JOURNAL

OF THE

## WASHINGTON ACADEMY OF SCIENCES

VOLUME 41

February 1951

Nó. 2

ARCHEOLOGY.—*A survey of new archeological sites in central Pataz, Peru.*<sup>1</sup> PHILIP D. CURTIN. (Communicated by Gordon R. Willey.)

### TOPOGRAPHICAL SETTING

The province of Pataz (see map, Fig. 1), located at the eastern edge of the Peruvian highlands, enjoys an isolation that is uncommon even in rural Peru. Not only is it too far east to be in the orbit of the ancient north-south route through Huamachuco, Cajabamba, and Cajamarca, but its own terrain has prevented its extensive use as a jumping-off place for one of the several trails from the highlands into the eastern jungle. Aside from pure distance from the centers of population in the highlands, like Huamachuco, Pataz is also cut off from the main body of the mountains by the cañon of the Marañon River, which forms a barrier from south to north. Pataz is simply the western slope of the final eastern range of the Andes. From the Marañon, flowing at an altitude of 1,300 meters in the Pataz region, to the top of the eastern *cordillera* at more than 4,000 meters the distance as the crow flies is only 14 km at some points and nowhere more than 25 km. The Marañon and the crest of the eastern *cordillera* form the western and eastern boundaries of the province. This gives the whole province the effect of being turned up at an angle of about

20°, but this slope is not uniform. The valley of the Marañon was once a pleasant saucer-shaped valley with the river flowing on hard rock strata at about 2,500 meters. Once these strata were worn through, the river cut through the softer material leaving a cañon with extremely steep sides falling off more than 1,000 meters from the original valley floor.

The difficulties in crossing the Marañon, even by mule, have retarded the economic development of Pataz, but in recent years two mining centers have grown up at Retamas and La Paccha. Until now the mines have been supplied by mule trains from across the Marañon and by air to a small landing strip at the southeast end of the Laguna de Pías. A highway from Huamachuco to Chagal on the Marañon and from there to Tayadamba, passing through the mining centers has been under construction for some years and may be finished by 1951.

In addition to the inaccessibility of the region from the central highlands, the eastern tributaries of the Marañon have cut the province transversely, at some points to the depth of the Marañon itself. In central Pataz there are two such barriers. One of these is the valley formed by the Parcoy River, the Laguna de Pías, and the Alpamarca River. The second is the river valley formed by the Rio de la Playa rising near Buldibuyo and the Rio de Cajas rising near Tayabamba. These join at Huaylillas to form the Rio de Nahuinbamba flowing into the Marañon at Puente Jocos. These two deep valleys effectively separate the central massif and the high *puna* lying between Chilia, Parcoy, and Buldibuyo from the regions centering around Tayabamba to the south and the town of Pataz to the north.

<sup>1</sup> This report summarizes the architectural findings of an expedition to Pataz during a part of the months of July and August, 1949, sponsored by the Institute of Anthropology of the National University of Trujillo, Peru. The personnel included the author, Luis Gutiérrez, John Ladd, Mrs. Helen P. Ladd, and Mrs. Phyllis Curtin, all of whom contributed to the preparation of this report. The author is indebted to Richard Schaedel, the director of the Institute of Anthropology, and to Drs. José Eulogio Garrido and Manuel Zavaleta C., of Trujillo, for their assistance in the field. He also wishes to express appreciation for consultations with Drs. A. Kidder, II, and Wendell C. Bennett. Sr. Gutiérrez is preparing a report on the ceramic and skeletal materials from Pataz, which will appear elsewhere.

The expedition in 1949 confined itself to a survey of the archeological remains in the central area, that is, to the area between the Nahuimbamba on the south and the Parcoy on the north. This forms a small natural geographical region centering around

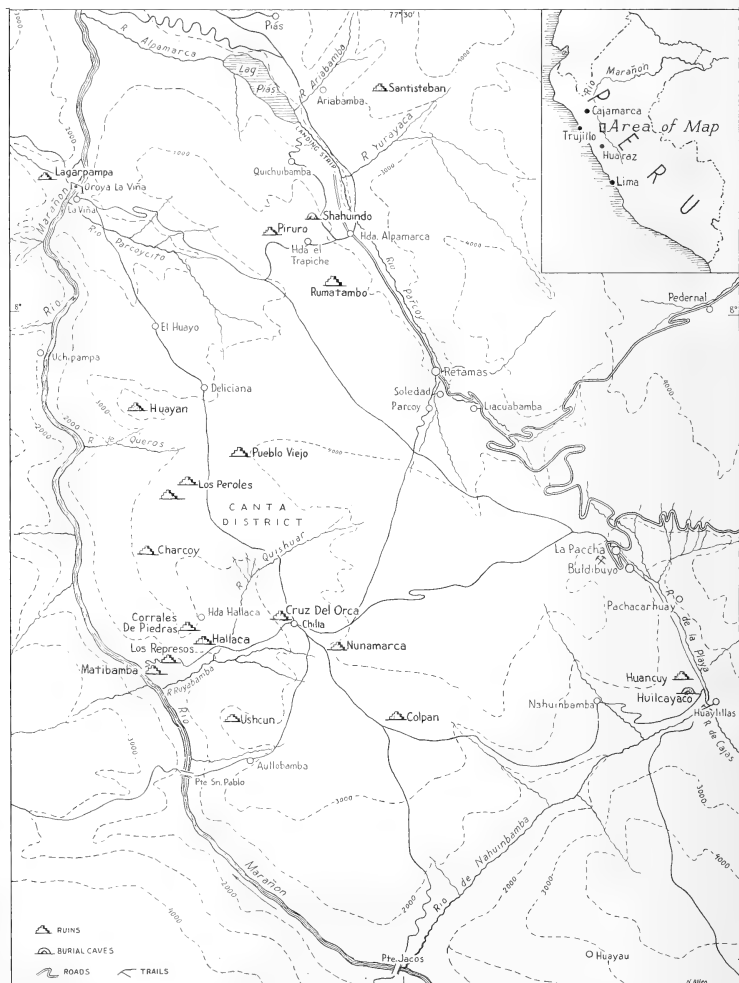

FIG. 1.—Map showing archeological sites in central Patatez, Peru.



the town of Chilia and its rich valley. Although this region is not large, there are enormous climatic variations. In the high *puna* within the triangle Chilia-Parcoy-Buldibuyo the cold high grasslands are used principally for sheep raising. Lower down transportation animals are grazed. Still lower in the valleys of Chilia, of the Parcoy, the de la Playa, the Parcoycito, and the Queros the normal Andean crops of maize, wheat, potatoes, and alfalfa are grown. In the cañon of the Marañon there are no crops below the altitude of 2,500 meters because of extreme aridity. Only desert vegetation is found from that altitude to the bottom of the cañon. Along the banks of the river itself small areas are irrigated and planted in coffee, oranges, mangoes, and bananas. Surplus agricultural products are mainly sold to the two mining centers at Retamas and La Paccha, but a small amount is also exported across the Marañon.

#### CHILIA

The present village of Chilia, at 3,170 meters in the center of the arable area, was not an ancient habitation site. It was formed, according to local legend, under the Viceroy Toledo in the late sixteenth century from the two older villages of Chilia and Charcoy located on opposite sides of the valley. The tradition of the two separate villages is still strong and has a part in many local rivalries. Nevertheless, the *patasinos* generally have forgotten Quechua and any precedent languages and speak only Spanish. Casual observation seems to indicate that the population is almost entirely mestizo.

In spite of its relatively recent origin, Chilia has come to have more stone sculpture than any site found in Patáz. The



FIG. 2.—Stone relief slab with feline motif, Chilia Village.

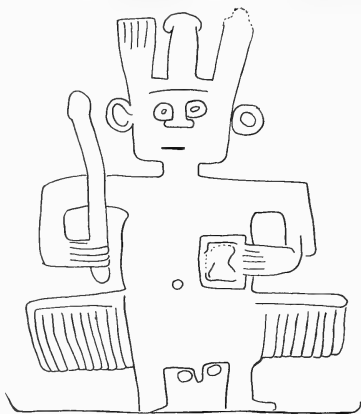

FIG. 3.—Warrior figure 86 cm high from stone relief slab, Chilia village.

ancient citadel of Nunamarca is close to the village and has supplied almost all of the building stone used in its construction. The inhabitants have also gathered a number of stone slabs carved in relief. These are kept as decorative pieces for door sills or for decoration within the houses. Twenty-four pieces were examined, though there are surely many more in the vicinity.<sup>2</sup> These fell into moderately well-defined motif categories. Of the 24 examples, eight had designs depicting felines. These are carved in relief 5 to 10 mm high on one side of stone slabs about 20 cm wide by 50 cm long and 10 cm thick (Fig. 2). These figures showed no particular orientation of the head to the right or the left of the slab, but all faces were shown full-face and had a strong tendency toward anthropomorphic features. All tails were curved upward. The number of toes shown on the feet varied from one to four, with several examples having two very birdlike toes. In addition to the eight slabs showing a single

<sup>2</sup> The National Museum at Pueblo Libre has a collection of stone sculpture from Chilia and Nunamarca made by Dr. Julio Tello in the late thirties. Unfortunately, Dr. Tello did not publish a report on this expedition before his death, and the National Museum does not indicate the exact provenance of these exhibits. In addition to the sculpture types found in 1949, this exhibit includes head-tenons from the Chilia area.

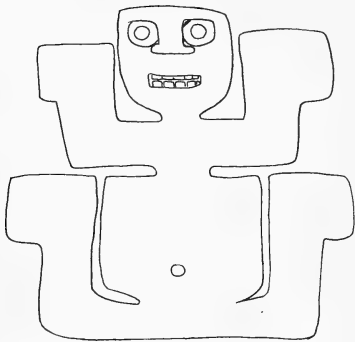

FIG. 4.—Figure 35 cm high from stone relief slab, Chilia Village.

feline, two slabs showed two feline figures. One of these had two typical felines with their heads together at the center of the slab. The other was similar, except that the two felines shared a single head, having one body on either side.

Next to the feline, the most common figure on relief slabs was a warrior figure, occurring on five slabs of the 24. Typically this is a full-length figure of a man holding a club in one hand and a trophy head in the other. The only clothing commonly shown is a 3-element crown on the head, ear plugs, and an ornament resembling wings projecting on either side of the body from the hips. Genitals are often shown (Fig. 3).

Third in frequency of occurrence is a full-face anthropomorphic figure with both arms and legs in the air, occurring in four of the 24 examples. The arms are shown straight out from the shoulders and then upward at a right angle from the elbow (Fig. 4). The legs are bent outward from the hips and upward from the knees. The only clothing shown on this type of figure is a three-element crown worn by two of the four examples.

The remaining stone sculpture is not clearly classifiable by groups. Three of the five remaining designs were geometric in character (Fig. 5) and showed no recognizable naturalistic motif. Of the remaining two, one showed a monkey in sitting position (Fig. 6). The other was a human head

in the round, very roughly carved in the natural rock about 26 cm high and 13 cm in diameter.

#### NUNAMARCA

Closely associated with Chilia village there are two archaeological sites. The more important of these is Nunamarca, the largest site discovered in Chilia Valley. It is located at the top of a rocky promontory jutting into the center of Chilia Valley at an altitude of about 3,500 meters, or 300 meters higher than Chilia itself (Fig. 7, *b*). These ruins can be reached from Chilia by following the mule trail toward Buldibuyo for about 4 km and then turning off sharply to the right at the farm of Augusto Dominguez. This house roughly marks the northern limits of the site. To the south and west the site is bounded by the steep sides of the bluff.

At present Nunamarca is in a very bad state of preservation. It has been cultivated for some generations as well as being used as a quarry for building stones over the last several hundred years. Few of the former walls can be traced, but large numbers of cut stones are now piled up or built into walls to clear them from the fields. The remains of walls and building stones, however, still cover an area about 500 meters in length by 200 meters in width, an area considerably larger than the present village of Chilia. At the southern border of the site area, overlooking the bluff and cliffs, there is an extensive retaining wall about 150 meters in length and 10 meters to 12 meters in height, the total height being broken by a terrace about 1 meter wide some 5 meters from the top of the wall. This wall is con-

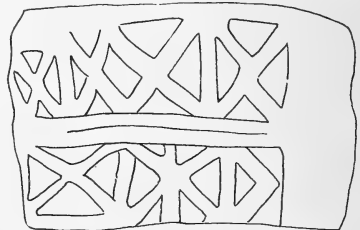

FIG. 5.—Laticelike design in low relief on slab 67 by 47 cm, Chilia Village.

structed of rows of faced stones 30 cm or more in height broken by alternate rows of stones no more than 5 cm in height. An adobe mortar was used and the rows are somewhat irregular. Toward the eastern end of this wall about 2.5 meters from the top there is the entrance to a gallery about 1 meter square faced with stone and covered with a single stone lintel at the opening. According to local informants this was formerly open for some distance under the site, but a second shaftlike entrance at the top of the ruin was filled a few years ago. The dirt from this fill now blocks the gallery a meter or so beyond the entrance.

Although the sculptured stones in Chilia village originally came from Nunamarca, only one piece of sculptured stone was found at the site itself. This was a slab about 60 cm in diameter, having a design of six concentric semicircles cut into it to the depth of about 1.5 cm. The entire site area was rich in potsherds on the surface.

#### CERRO DE LA CRUZ DEL ORCA

The second site associated with Chilia village is Cerro de la Cruz del Orca, located about 1 kilometer to the west of Chilia on the ridge slightly below the village. It can be reached by trail on foot in a few minutes. At present the visible remains are undistinguished, being nothing but a single platform constructed on a small point of land. This platform is 10 meters to 15 meters in diameter and is supported by a stone retaining wall about 5 meters in height, now largely fallen down. A great deal of ceramic material was found on and around the platform and at places where the sides were badly eroded sherds were found in the earth and rubble fill of the platform at a depth of about 2 meters. The people who farm the site area informed the author that there is a cave nearby which is associated with the ancient inhabitants and is now inhabited by evil spirits.

#### THE CANTA DISTRICT

In the Canta district of Chilia three prehistoric habitation sites were examined. For lack of definite local names, these have been called Canta I, II, and III. All three are located within a few hundred meters of the easterly of two mule trails from Chilia to-



FIG. 6.—Monkey figure 18 cm high from relief slab, Chilia village.

ward Hacienda "Deliciana." Canta I is about 5 km from the village, while Canta II and Canta III are about 2 km farther along.

From the distance Canta I appears to be a low hilltop covered with brush. Beneath the underbrush and extending down into the cultivated area below there are three large concentric terrace levels, varying in width from 15 to 40 meters and following the conformation of the hill. In the middle of the highest terrace level there are remains of a truncated pyramid rising in small steps and faced with stone. The site area, especially the upper levels where walls have not been disturbed by cultivation, is covered with houses and the remains of walls in varying states of preservation. Two principal types of wall construction were observed. The most common, especially for retaining walls, was ordinary *pirca* using stones of medium and uniform size and faced on the outside. A more elaborate form makes use of alternating rows of thick and thin stones, similar to the type described in connection with Nunamarca. Because of the heavy cover of vegetation it is impossible to estimate accurately the number of house outlines, but the extent of the site area now covered with stone work indicates that it was once occupied by a moderately large population. Clearing and excavation would be necessary to show the ground plan and the true extent of the site.

Canta II also consists of a series of concentric circular terraces around a natural hilltop about 60 meters in height. It is much smaller than Canta I, the lowest terrace level being only about 300 meters in diameter. The retaining walls of the terraces are of ordinary uniform *pirca* faced on the outside only, but a large number of completely finished rectangular building stones were observed on the various levels, presumably the remains of structures that have since been torn down to provide stones for more recent building. The only remaining structures on the terrace levels were circular walls 3 to 4 meters in diameter and about 1 meter in height. These are the outlines of the house type most commonly found in Central Pataz. Canta III is a slightly smaller version of Canta II, occupying another hilltop on the same ridge.

#### PUEBLO VIEJO SOBRE PARCOYCITO

On the ridgetop dividing Chilia drainage from the Parcoycito and Queros valleys there is a succession of habitation sites, fortresses, and pyramids. Seven of these sites were examined in 1949. The highest and most easterly is Pueblo Viejo, located at an altitude of about 3,800 meters on the ridge between the headwaters of the Rio Quishuar and the Rio Parcoycito. It can be reached from Chilia by taking either of the northern mule trails toward La Viña, since these trails rejoin in order to cross the pass into the valley of the Parcoycito. At this pass, about 15 km from Chilia by either trail, a rough path can be seen branching off to the eastward and following the height of land up the ridge. This trail passes through the site of Pueblo Viejo after a climb of about 3 km from the pass.

The site consists of a dwelling area on the high *puna* surrounded by defense works. As the ridge rises eastward from the pass the ascent is steep and unbroken until a small point of land is reached. From this point eastward for about 1 km the ridge ceases to climb and swings in a wide semicircular bow to the south. Within the bow to the north of the ridge and about 20 meters below it at its lowest point there is a relatively flat sheltered area measuring perhaps 400 by 200 meters and covered by the remains of the principal dwelling area. The point at the

western limit of the site is terraced in the style of Canta II, and the ridge top is terraced and covered with house outlines of the round type met at Canta II as well as rectangular houses about 2 meters in width by 4 meters in length.

In the dwelling area itself there are two principal types of structure. The most common are circular enclosures about 20 to 30 meters in diameter having outside walls 1 to 2 meters in height (Fig. 7, *d*). Within these enclosures there are stone walls outlining smaller circular buildings 3 to 4 meters in diameters. These are irregularly placed, occasionally having part of a wall in common or partly depending on the wall of the larger enclosure, but in general there is a small court or plaza in the center. In all there are 10 to 14 enclosures of this type. The second type of structure in the dwelling area is a larger rectangular building with thick walls now 2 to 3 meters in height in some of the better preserved examples. The exact ground plan of these remains could not be discovered without removing the fallen rock and rubble that covers most of their location. It is also now impossible to tell whether this structure represents a group of buildings or a single large one.

To the north of the dwelling area and a little below it, there is a single wall running from east to west enclosing the area on the single side not enclosed by the ridge. This wall is about 800 meters in length and about 2 meters high. Eastward along the ridge about 1 km from the dwelling area there are further defense walls. These cross the ridge transversely, protecting the site from attack directed down the ridge from the heights (Fig. 8, *d*). From west to east this system contains three elements—a wall 1.5 meters high, a wall 4 meters high followed by a ditch 3 meters deep, and a wall 2 meters high followed by a ditch 2 meters deep. Unlike the northern defense wall nearer the dwelling area, the southeast walls are embankments perhaps 2 meters wide made of the earth piled up in the construction of the defense ditches or moats associated with them. The embankments are faced with a vertical retaining wall on the west side, away from the village. These walls are rough *pirca* faced on the outside. Of the three walls,



FIG. 7. Architecture and views of central Pataz: *Upper left (a)*, West wall, upper level of Los Peroles, showing cornice; *upper right (b)*, Chidra Valley and Nutamarca (center) from the northwest; *lower left (c)*, Piruro; *lower right (d)*, portion of a round house. (courtesy, Pucallpa Viejo)

only the middle one extends for any distance down the sides of the ridge, in this case for about 1 km to the south.

Within the site proper three types of construction were observed. Some of the houses on the ridgetop are made of uncut, unfaced *pirca*. The round groups within the dwelling area are similar except for facing and more careful workmanship. The rectangular buildings within the dwelling area and the northern defense wall are constructed of large stones 30 cm or more in diameter interspersed with smaller flat stones. The large stones are not laid in regular courses, but placed evenly through the smaller construction. In spite of the similarity of this stone work to the alternate courses of large and small stones found at other sites, only the uncoursed type was found at Pueblo Viejo.

#### LOS PEROLES DE HUAMPO

Passing from the site of Pueblo Viejo sobre Parcoycito to the westward along the ridgetop, the next site is Los Peroles de Huampo. Los Peroles occupies a position to the west of the pass between Chilia and the valley of the Parcoycito corresponding to that of Pueblo Viejo to the east. Leaving the mule trail between Chilia and La Viña and following the ridgetop to the west the site is found at about 3,400 meters after a brief continuous ascent. Beyond Los Peroles the ridge drops again and splits into two branches. One fork swings to the southward around Chilia Valley, while the other forms the south watershed of the Parcoycito rising to the heights of Huayan. Between the two forks the Queros River drains a small valley and empties into the Marañon.

At Los Peroles the most important elements are two structures on the open summit of the ridge, a platform (structure I) and a pyramidal group of concentric terraces (structure II). In addition there are a number of defense works, house frames, and terraces. Approaching the site from the east along the ridge a defense ditch about 1 meter deep lies transversely across the ridge. From this point three sloping terraces partially covered with round house frames of the familiar type rise to structure I, the more easterly of the two. This is a square stone-

faced platform about 7 meters high and 14 meters square. The sides of the square are oriented so that they face directly toward the four points of the compass, but this is not necessarily intentional, since the north and south sides are parallel to the line of the ridgetop. On the top of the square platform there are six round house outlines of the usual type. In addition, toward the northwest corner of the structure there is a vertical shaft about 1 meter square, the sides of which are lined with faced stone work. At present this is about 2 meters deep, but the bottom is loose earth and rubble indicating that it may have been deeper.

Structure II lies about 130 meters to the west of structure I. The two are separated by a dip in the ridgetop about 30 meters lower than the top of either. At the bottom of this dip a second transverse ditch about 2 meters deep crosses the ridge. Above the dip to the west structure II rises in a series of three wall-supported terraces. The three retaining walls are each about 7 meters high, giving the whole a uniformity with the 7-meter height of structure I. Since the lowest of the retaining walls rises from a terrace cut into the natural slope of the hill, there are four terrace levels in all. The three lower levels are concentric and elliptical being roughly accommodated to the shape of the ridge—the fourth and highest alone being nearly round. The whole structure measured at the lowest level is 95 meters in length by 25 meters in width. The terraces are not completely symmetrical. Since the eastern slope is less steep than the western, the terraced levels on that side average 16 meters in width, while the same levels to the west measure only 11 meters each. The three lower terraces are uniformly 3 meters in width toward the north and south, giving the structure its elliptical shape. The central round level is 13 meters in diameter. All the retaining walls are constructed of faced stone, roughly rectangular, coursed, and having alternate courses wider than the rest. About 50 cm below the top of the highest wall there is a cornice formed by one course of stones that projects about 10 cm from the wall (Fig. 7, a).

As with structure I, all the terrace levels show the remains of house circles varying

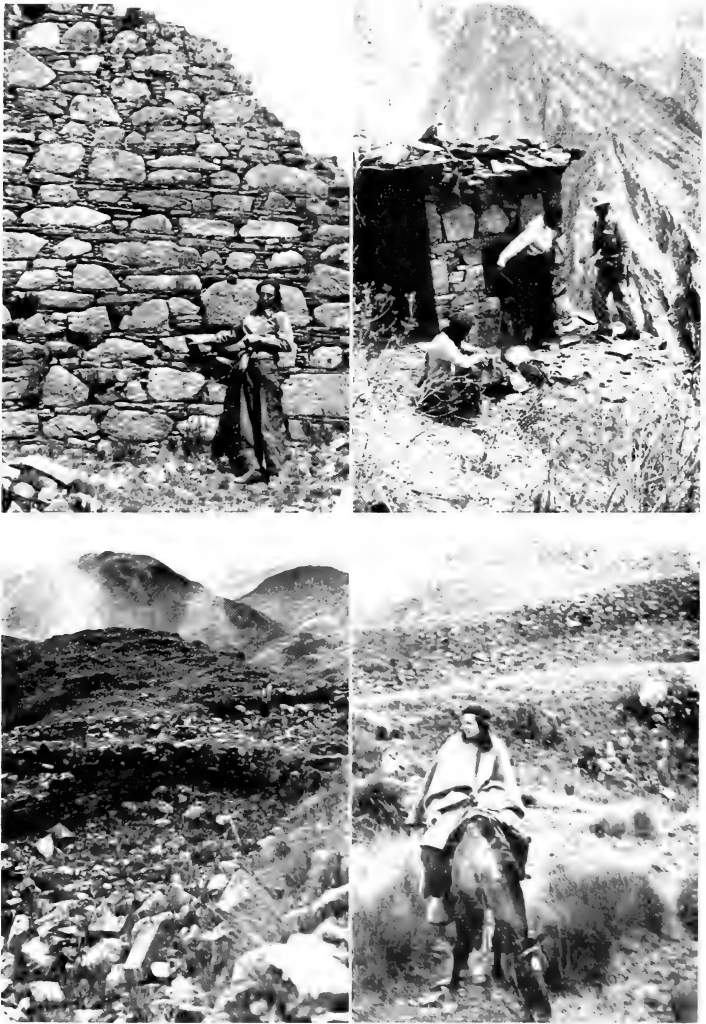

FIG. 8.—Architecture and views of central Pataz: *Upper left (a)*, North wall of principal structure, Charcoy; *upper right (b)*, west side, upper story, Matibamba chulpa; *lower left (c)*, house remnants at Charcoy looking north, heights of Huayan in the distance; *lower right (d)*, eastern faced earthworks and defense ditches at Pueblo Viejo.

in number from four on the highest level to about 14 on the lower levels. No rectangular house outlines were observed. In the middle of one of the house circles on the third terrace level there is a vertical shaft similar to that observed on structure I. At first this was taken for a treasure-seekers' hole, since it was not lined with stone. A closer examination, however, showed that it connects with the remains of a horizontal gallery entering the base of the retaining wall just above the second level.

Associated with these two principal structures there is a small village of round houses on the side of the ridge a few hundred meters to the southwest as well as a number of house circles on the ridge itself to the east and west of the site. In addition a large group of terraces and houses were observed farther to the west between Los Peroles and Charcoy, indicating that virtually the entire ridge top was once occupied. The center of this group is a terraced hilltop about 3 kilometers west of Los Peroles. There is no known local name for this site.

#### CHARCOY

Continuing along the crest of the ridge past this last site, the ridge drops steeply forming a pass. Through this pass there is a trail connecting Chilia village with the valley of Queros. Beyond the pass the ridge rises very steeply for about 3 km. There is no trail, but animals can travel fairly easily along the treeless summit, forcing riders to dismount only occasionally in especially steep or rocky slopes. Over this rise the ridge slowly bends to the south, until its direction is almost north and south. Charcoy occupies the highest point after the new ascent, being at about 3,700 meters, or almost as high as Pueblo Viejo and a good deal higher than Los Peroles. The site is clearly visible from Chilia village, since the higher walls stand out against the skyline.

The remains of Charcoy are very extensive, though many of the walls are now nothing but scattered pieces of cut stone (Fig. 8, c). Along 500 meters of the ridgetop, which is 500 to 100 meters wide and relatively flat at this point, there are about 60 houses in good condition. Of these around 80 percent are of the round type. The remainder are rectangular of the type found on the ridge

at Pueblo Viejo. Some of the house circles are arranged within enclosures on a plan similar to that at Pueblo Viejo.

At the center of the ruined area the corner of one structure shows the most careful stone work observed in Patatz. The only remains of a larger building, however, are a corner and two side walls extending about 7 meters in one direction and 12 meters in the other. The longer of these two sides is oriented in a general north-south direction, but again this is the direction of the ridge. Inside this building there are the remains of two rooms, each about 1.3 meters square. These are side by side along the east wall with doorways opening toward the inside of the building toward the west. In this area the stone and rubble of fallen walls make it impossible to trace the ground plan without excavation. At one time the standing portion must have been part of a much larger building. Even at present the wall is higher than 5 meters at its highest point. The construction of inside and outside walls is identical. The walls are between 68.5 and 76 cm thick constructed of a red clay and rubble fill faced on both sides with cut rock in alternate courses of large and small stones (Fig. 8, a).

A cursory survey of the site revealed only three examples of decorated stone, but among many thousands of cut stones in the area there are probably a number of others. Two of these stones were slabs about 10 cm thick and 70 cm square bearing an incised rectilinear geometric design. They could have been either an individual decoration or a portion of a larger motif running along a number of facing slabs. The third decorated stone bore a single incised serpentine line having nine reverses of direction. This might represent a snake or be a merely decorative line.

#### CORRALES DE PIEDRAS

Six kilometers farther south along the same ridge from Charcoy is the site of Corrales de Piedras. This can be reached either by the ridgetop route, or by going directly from Chilia to Hacienda "Hallaca," where a guide can be secured to point out a more direct route up the ridge. The latter route is more difficult, but shorter.



Corrales de Piedras has a general appearance and location similar to Charcoy. It is also situated on the top of the ridge, and its principal features are a number of terraced hilltops and dwelling areas scattered along the ridge for about 1,500 meters. The area is larger than that of Charcoy, but settlement does not seem to have been as dense. Corrales de Piedras' altitude of 3,300 meters is also sufficiently lower than Charcoy to be out of the completely treeless area. Parts of the site are covered by thick underbrush, although this sort of vegetation does not normally grow so high. The site is clearly visible from Chilia village and is especially marked by the brush, the only vegetation other than grasses that appears on the skyline to the northeast.

Approaching Corrales de Piedras from the north, the first evidence of former habitation is a very elaborate system of defense walls and ditches constructed in the same manner as those to the east of Pueblo Viejo. The principal difference at Corrales de Piedras is the remains of a portal through one of the walls. Here there is an opening about 1 meter wide with an upright stone jamb about 50 cm in diameter and 1 meter high on either side. Immediately beyond the wall system is the first of two points of land terraces in the usual manner. Between these the brush covers a slight saddle in the ridge, obscuring the layout of a large number of partially ruined structures of faced *pirca*. Beyond the saddle the ridge rises again through a series of four well-preserved terraces to the second high point. The levelled top of this point, as well as the terraces and the hillsides to the east and west of the ridge show the remains of a number of round houses similar to those at Charcoy and Los Peroles. Beyond the second point the ridge slopes down rather steeply through a series of nine terraces to a very small platform about 5 meters in diameter. These terraces also have the remains of house circles. From the last platform the ridge slopes downward so abruptly that it is only passable by animals with the greatest difficulty. After about 2 km this slope breaks into an impassable series of cliffs, marking the end of the ridge to the south.

#### HALLACA

A small point of land just above the cliffs to the south of Corrales de Piedras is the site of a number of concentric stone faced terraces at about 3,000 meters altitude. This small point is so isolated on the steep hillside that the use of its terraces for purely agricultural purposes seems unlikely. It may have served as an outpost for Corrales de Piedras or as a small fortress to control traffic over one of the trails passing from the valley of Chilia to the Marañon. This trail now passes through a small natural gateway between the site and the main slope of the ridge. The site is clearly visible from the Hacienda "Hallaca" buildings which lie about 2 km to the northwest directly below Corrales de Piedras. Hallaca is reached from Chilia in two hours by mule by turning off the westerly trail to La Viña about 6 km from Chilia.

#### LOS REPRESOS

Los Represos is much lower in altitude than the ridgetop sites discussed above, but its general characteristics are the same. It is located at about 2,000 meters on a short ridge extending into the Marañon Valley between the Río de Ruyabamba on the south and the Marañon itself on the north and west. Los Represos is reached from Chilia in about four hours by mule over a good trail that follows the northern side of the Ruyabamba Cañon to the orchards of Matibamba at the bank of the Marañon. At the point where this trail crosses a ridge from the drainage of the Ruyabamba to that of the Marañon the site is seen on the trail itself and toward the west down the ridge.

The local name, Los Represos, comes from the site's distinctive feature. There are two depressions or plazas in the top of the ridge about 16 meters in diameter and lined with stone to the depth of about 1 meter. These are thought to be water reservoirs connected with an irrigation system for the Marañon Valley, especially for the site of Matibamba, which lies directly over the ridge to the north. They seem rather small to store any considerable quantity of water, and no other irrigation works were noticed in the area. At present there are no sources of water within 5 or 6 km of the site.

In addition to the two "repros", there are three other structures on the ridge. Two of these are single level square stone faced platforms about 3 meters in height. The third is a large rectangular platform a little more than 3 meters high with a square platform of the same height on the top, giving a pyramidal effect. All retaining and lining walls are of average uniform *pirca*. The double platform contains a large treasure-seekers' hole in the middle of the highest level. On the second level there was a small round low platform about 3 meters in diameter with a square shaft about  $1\frac{1}{2}$  meters in width in the center.

#### MATIBAMBA

Following the trail over the ridge and down into the Marañon to the north of Los Repros there are a series of hairpin turns leading to the cañon floor. Here, along the edge of the river at 1,320 meters, is the small settlement of Matibamba and an irrigated area in which tropical fruits are raised. Above the irrigated area for about 500 meters and extending along the valley for the same distance are the ruins of Matibamba. Throughout the site area there are the remains of low walls and terraces covering the arid hillside. Because of lack of water en route from Chilia, the presence of *veruga*, very high temperatures, and other special problems imposed by the location of the site, we were unable to make the full survey that the area deserves.

The most interesting structures at Matibamba are the remains of five *chulpas* in the western part of the site area about 250 meters from the Marañon. One of these is almost perfectly preserved, although any burials it may once have contained are now gone. The well-preserved *chulpa* is a small two-story building—a square room or tower set on top of a round base. The base is constructed in the form of a semi-circle on the very steep hillside, the top being flush with the hill while the lower northern side is about 3 meters high. The diameter from east to west is approximately 6.2 meters, while the radius from north to south is 4.3 meters. The construction of the lower walls is a rubble and earth fill with stone facing. The facing stones are of varying size and are not

coursed. This wall varies in thickness from a little more than 1 meter to more than 2 meters. Within the round lower structure there are two chambers entered from a small opening at the west corner. The northern and larger of these is in the shape of a half-moon about 3.4 meters in length and 1.7 meters in width having a maximum height of 1.25 meters. An opening into the smaller southern chamber is found at the northeast side of the larger, opposite the opening to the outside. The inner chamber is rectangular, about 3.2 meters in length by 96 cm in width with a maximum height of about 75 cm. At the eastern end of this chamber there is a window roughly 60 cm square. Both of the lower chambers have corbelled roofing which provides the floor for the structure above, additional support for this roof being supplied by the wall separating them.

The upper story of the *chulpa* is a boxlike building 2.84 meters square (Fig. 8, b), having a single window on the eastern side 58 cm square about 60 cm above the ground. The walls of this building are roughly 37 cm thick, being constructed in a pattern of three courses which repeats itself three times in the 2-meter height of the walls. This begins at the bottom with a course of very large faced stones in the neighborhood of 30 cm in height placed side by side but filled with smaller stones where necessary because of their irregular shape. Above this course is an area of flat stones, also faced, typical of the small stone layers of the alternating large and small courses found at Charcoy. This layer fills in and around the large lower layer making a relatively level surface on which there is a course of large flat stones measuring about 12 cm by 40 cm. The pattern is then repeated with a new layer of the very large irregular stones. The placement of the window and the height of the pattern are so arranged that the bottom of the window and the lintel over it are supplied by consecutive courses of the long flat variety. On the whole the pattern is followed consistently on all four sides, but there are occasional irregularities. The roof of the upper level is also corbelled, being 70 cm thick and constructed of large flat stones very irregularly placed without mortar.

Farther to the west there are three additional *chulpas* in a very bad state of disrepair. These are placed in a row on the hillside, one below the other. A fifth *chulpa* lies some distance up the hill to the south of the well-preserved example, and a closer examination of the ruins will probably reveal more.

Although the well-preserved *chulpa* is on the unterraced hillside, 8 meters up hill there is an artificially leveled area about 10 by 3 meters protected by a stone retaining wall on the upper side. On this level there are the remains of a rectangular structure. The only remaining wall in good condition is in the shape of an "L" about 2.7 meters high at the corner and 2 meters long toward either arm. This wall has a projecting corbel about 40 cm from the top.

At the eastern end of the Matibamba ruins there is another wall in excellent preservation. This appears to be the remains of a rectangular building about 6 meters high standing on an artificial terrace. This "iglesia," or temple, as it is called locally, appears to have once had two stories and in many respects to be similar to the large central structures at Charcoy and Pueblo Viejo.

#### SITES SOUTH OF CHILIA VALLEY

Matibamba is the last of the seven sites examined along the north rim of Chilia Valley. According to local reports and examination from the distance there are fewer sites along the corresponding ridge to the south. The most prominent of these is Ushcun (see map, Fig. 1), lying on the southern ridge overlooking the Ruyabamba opposite Corrales de Piedras on the north. Some stone sculpture and burials are reported there.

Still farther to the south, the extensive ruins of Cólpan are found at the height of a pass between the valleys of the Aullobamba and the Nahuinbamba. These ruins consist of buildings and terraces similar to those examined in detail. Another similar group of ruins is Huancuy, found about 15 km south of La Paccha on a high point ringed with concentric terraces. This ruin is located just above Cachipiza on the valley floor and seems designed to protect the pass where the

present trail crosses the shoulder of the mountain into the valley of the Nahuinbamba. This site was visited by Raimondi in 1860.<sup>3</sup>

#### PIRURO

To the north of the valley of Chilia, the site of Piruro presents a classic example of the hilltop structures found in Patáz (Fig. 7, c). It lies about 500 meters to the northwest of the mule trail from La Viña to Alparmarca at the height of a small pass about 3,200 meters in elevation immediately before the final descent into the Parcoy valley. The situation is very striking for its location, giving a clear view up the valleys of the Ariabamba and Yurayaca as well as a large part of the valley of the Parcoy. Approaching by way of La Viña, Piruro is visible from the trail for several hours before actually arriving at the site.

The structure itself consists of a large oval platform about 90 meters long by 50 meters wide. The sides of the platform now slope down to the hilltop about 8 meters below, but they may once have been faced with stone. On top of the platform there is a truncated pyramid about 8 meters high, being roughly 12 meters in diameter at the top. There are some sections of former retaining walls, but in most places these have been removed for modern buildings or walls. On the west side of the pyramid, where the walls are best preserved, there are indications that the sides once rose in four steps about 3 meters wide. All the remaining walls are of normal *pirca* construction with no pattern of large and small stones. Although a large number of well-cut rectangular stones were found near the site, none of these were in place. On the eastern side a treasure-seekers' excavation has completely removed a large part of each level.

#### PARCOY VALLEY

In addition to Piruro there are other sites in the vicinity of the Parcoy valley, though they were not examined in detail by the expedition in 1949. Rumatambo, overlooking the Parcoy near the Hacienda "El Tra-

<sup>3</sup> RAIMONDI, ANTONIO. *El Peru* 5: 125. Lima, 1874-1913.

piche," is one of these. The portion visible from the valley below is a retaining wall system circling a hilltop at about 3,100 meters in elevation. Santisteban is reported on the ridge between the rivers Yurayaca and Ariabamba but was not examined.

Along the south bank of the Lagarpampa or Sauce River, which empties into the Marañon 1 km north of La Viña, there is a series of parallel agricultural terraces, formerly watered by an irrigation canal bringing water from the upper Lagarpampa. In all, about 40 levels can be distinguished along the slopes above the Marañon. These are not only the most extensive system of terracing observed in the Pataz area but also the only system of parallel terraces, the others being only the concentric type. They are, perhaps, noteworthy as the only possible remains of Inca occupation, the other features of architecture, ceramics, and sculpture being clearly non-Inca in character.

#### HUILCAYACO CAVES

In addition to the ceremonial and habitation sites visited, investigations were made at two burial sites, both caves. The largest of these was visited by Raimondi (*loc. cit.*) at the same time he visited Huancuy. Continuing beyond Huancuy on the trail toward Nahuinbamba the cave is located between the mule trail and the Río de Nahuinbamba about 2 km past the site of Huancuy. It lies on the side of a very steep bluff about 3 km in a direct line from Huaylillas at an elevation of about 2,800 meters. Although the cave is difficult to find without local assistance, a guide can be secured in any nearby village by asking for the *cueva de los gentiles*. At the mouth the cave is only 1 meter wide by 50 cm high, the entrance sloping downward at an angle of about 20 degrees. Once inside it is somewhat bigger and finally at the depth of about 15 meters there is a room large enough for standing upright. Various side passages open in several directions from the central tunnel. In all parts of the cave, but especially in the first large room, there are numerous human skeletons. The cave shows signs of having been frequently entered in the past, but some of the skeletons were still partly articulated. No artifacts were found.

#### SHAHUINDO

The second burial caves examined are located on Hacienda "El Trapiche" not far from the site of Piruro. The caves are in the steep cliffs of Shahuindo about 1 km northwest of the hacienda buildings and 100 meters higher in elevation. They can be reached from the hacienda without the aid of ropes. Three caves open from a narrow off-set in the cliffs, bearing 308° magnetic from Trapiche Viejo. From south to north they have been numbered I, II, and III. Cave I has an entrance 1 meter in width by 20 cm in height. The floor is covered with unarticulated human bones mixed with earth. The whole has the appearance of having once been excavated and later replaced. At present the cave can be entered about 3 meters. No artifacts were found, but a thorough excavation of the floor might uncover much more than our brief examination revealed. Caves II and III are similar in size and condition. They are located 10 and 12 meters respectively to the north of cave I.

Other burial caves were reported in the Pataz area but were not visited. The burial caves at Ushcun are mentioned above. Caves were also reported near the headwaters of the Quishuar about 10 km to the north-northeast of Chilia village. Other caves are supposed to exist in the southeast slope of Nunamarca bluff, but could not be found in 1949.

#### SUMMARY AND CONCLUSIONS

Within the area under consideration the following types of structure occur:

- (a) Series of concentric terraces ringing a hilltop.
- (b) Artificial platforms with sloping sides and with vertical stone faced sides.
- (c) Artificial platforms superimposed in the form of a stepped truncated pyramid three or four layers in height.
- (d) Earth embankments faced with stone accompanied by moats.
- (e) Rectangular houses.
- (f) Round houses about 1 m. high and 3 to 4 m. in diameter.
- (g) Large rectangular buildings up to 5 m. in height.
- (h) Depressed plazas or reservoirs.
- (i) Galleries.
- (j) Stone lined shafts.

(k) Large circular enclosures surrounding groups of circular houses.

(l) *Chulpas*.

Five general types of masonry were observed in the Pataz region:

(a) Unfaced rough *pirca*.

(b) Faced *pirca* built with average uniform stones.

(c) Faced *pirca* built with large and small stones in alternate courses.

(d) Faced *pirca* of large stones placed at random throughout a wall of smaller stones.

(e) Faced *pirca* having a three-course repetitive pattern.

These masonry types are used either in walls completely of stone or as facing for clay and rubble walls or in retaining walls. Two additional features of the local stonework are the use of decorative corbels near the top of walls and of the corbeled roof.

Although a reconnaissance survey of this sort can not be comprehensive, even for an area as small as central Pataz, it allows limited conclusions about the type of architecture and the extent of archaeological remains to be found in the trans-Marañon region of Peru. But these conclusions must be very tentative, since the areas immediately surrounding Pataz on all sides have not been explored by archaeologists, even at the survey level. Particularly the southern part of Pataz, the provinces of Marañon and Pomabamba, and the general area between central Pataz and Chavin de Huantar merit a careful examination. Large ruins are reported at Tarrija and Uchos in southern Pataz and at Llayno near the town of Pomabamba. Even surveys in these areas would help to clear up many problems connected with the appearance in Pataz of traits associated with the cultures of the Callejon de Huaylas.

Among these traits, only to mention the most obvious, are stone-lined galleries, houses that were probably two-storied, and emphasis on the feline motif in stone sculpture.<sup>4</sup> The preponderance of round house outlines about 1 meter high and 3 meters in diameter as the ancient dwelling-house type in Pataz calls for special mention. The author observed nothing of this sort in current use

in Pataz, but this type, though uncommon, is still used in parts of the Callejon de Huaylas. In these present-day buildings, the base is a rough stone wall approximately the same height and diameter as those in Pataz, while the roof is a conical thatching supported by a vertical pole in the center, 4 to 5 meters high.

On the other hand, the Matibamba *chulpas* present a problem that must be left till further exploratory work is done. This type of square boxlike structure on a round base is striking, yet no examples have been reported in the surrounding regions, that is to say, at Chavin, in the Callejon, at Marca Huamachuco, or in the region of Cajamarca.

On a more general plane, the whole area of Pataz seems to have been formerly more heavily populated than it is today, even if it is assumed that all sites in the valley of Chilia were not occupied at the same time. Of the sites visited only Matibamba and Lagarpampa are not equipped with defense works or located in easily defensible positions. Several of the sites, notably Charcoy and Pueblo Viejo and Huayan, are located at almost 4,000 meters elevation, far above the arable area and far above any visible source of water. This raises the question of the prehistoric political situation. Against whom were these defenses built? A tentative answer is suggested by Garcilaso's statement that the pre-Incaic boundary between Huacrachuco and Chachapoyas was found just to the south of Ptas.<sup>5</sup> If this is true, the long valley of the Parcoy and Alpamarca Rivers forms a natural frontier. The heights to the south and west of the Parcoy, then, would be the natural defense line of Huacrachuco. It is possible that the chain of fortifications to the north of Chilia valley housed only garrisons. This would explain both the relative density of population on this ridge and the inaccessibility of the sites. Following this hypothesis only the sites on or near the valley floor like the Canta sites and Numamarca would be economically supported by the production of Chilia valley. The garrison sites could have been supported by a much larger area.

<sup>4</sup> BENNETT, WENDELL C. *The North Highlands of Peru*. New York, 1944.

<sup>5</sup> DE LA VEGA, GARCILASO (El Inca). *Comentarios reales*: pt. 1, bk. 8, chap. 1. Buenos Aires, 1945.

PALEONTOLOGY.—Check list of salinity tolerance of post-Paleozoic fossil Ostracoda.<sup>1</sup> I. G. SOHN, U. S. Geological Survey. (Communicated by J. S. Williams.)

Among microfossils Ostracoda are considered second only to Foraminifera as horizon markers. Their utilitarian value is enhanced by the fact that they occur in both fresh and salt water, whereas the Foraminifera are confined to salty waters. Although certain genera of ostracodes show remarkable tolerances to variation in salinity, none of the species belonging to those genera has to date been recorded as tolerant to both strictly fresh and strictly marine environments. Some species can live in water that grades

<sup>1</sup> Published by permission of the Director, U. S. Geological Survey.

from fresh to brackish; others tolerate brackish to marine water. Many genera and species are reported to be confined to each one of the several types of salinity environments.

The following table records the inferred salinity tolerance of 80 forms included in 36 genera. The species are those for which salinity habitat is specifically mentioned in the literature. The table is compiled as an aid to interpreting the depositional environment of sediments containing post-Paleozoic Ostracoda. It is the result of an objective survey of the literature and consequently may include some erroneous inferences, which future investigations will rectify.

LIST OF POST-PALEOZOIC FOSSIL OSTRACODES FOR WHICH A DEFINITE SALINITY HABITAT HAS BEEN INFERRED

Ostracode	Type of Water			Remarks	Reference
	Fresh	Brackish	Marine		
<i>Amonocythere</i> .....		×			21
<i>A. floridana</i> .....			×		21
<i>Bairdia oviformis</i> .....			×	Shallow warm water.	20
<i>Bythocypris</i> .....			×		17, 24
<i>B. simulata</i> .....			×	Shallow water.	6
<i>Bythocythere simplex</i> .....			×		19
<i>Candona ansata</i> .....	×	×			22
<i>C. bononiensis</i> .....	×				22
<i>C. forbesii</i> .....	×	×			11
<i>Cyprilla</i> .....			×		4
<i>Cypridea</i> .....	×	×		Thin shells fresh, thick shells brackish (10).	4, 10, 15
<i>C. dunkeri</i> .....	×	×		Slightly saline (1).	1, 22
<i>C. granulosa</i> .....		×			1
<i>C. granulosa</i> var. <i>fasciculata</i> .....		×		More saline than next below.	1
<i>C. granulosa</i> var. <i>paucigranulata</i> .....		×		Less saline than above.	1
<i>C. primaeva</i> .....	×				22
<i>C. punctata</i> .....	×	×		Slightly saline (1); fresh water (22).	1, 22
<i>Cyprideis</i> .....		×			15
<i>Cypridopsis compressa</i> .....	×				8
<i>Cyprione bristovii</i> .....	×				1
<i>Cypris purbeckensis</i> .....	×				22
<i>C. pygmaea</i> .....	×				22
<i>Cythere</i> .....		×	×	Marine-brackish (3, 7); marine (12, 23).	3, 7, 12, 23
<i>C. cornuta</i> .....			×	Shallow sea.	18
<i>C. crispata</i> .....		×	×		7
<i>C. drupacea</i> .....			×	Shallow water.	6
<i>C. limicola</i> .....			×		19
<i>C. retirugata</i> .....		×	×		22
<i>C. transiens</i> .....		×	×		22
<i>C. tuberculata</i> .....			×		19
<i>C. visceralis</i> .....			×		22
<i>Cythercis</i> .....	×	×	×		16
<i>C. convexa</i> var. <i>sarmatica</i> .....		×			13, 24
<i>C. ornatissima</i> .....			×	Shallow sea.	18
<i>C. serpentina</i> .....			×		22
<i>Cytherella</i> .....			×	Typical marine.	17
<i>C. muensteri</i> .....			×	Shallow sea.	18

LIST OF POST-PALEOZOIC FOSSIL OSTRACODES FOR WHICH A DEFINITE SALINITY HABITAT HAS BEEN INFERRED—*Continued*

Ostracode	Type of Water			Remarks	Reference
	Fresh	Brackish	Marine		
<i>Cytherelloidea williamsoniana</i> .....			×	Shallow sea.	6
<i>Cytheridea</i> .....		×	×	Shallow marine, estuarine.	3, 7, 12, 14
<i>C. calyptroides</i> .....			×		22
<i>C. eusarca</i> .....		×	×		22
<i>C. helvetica</i> .....		×			14
<i>C. hungarica</i> .....		×			24
<i>C. longicaudata</i> .....			×	Shallow water.	6
<i>C. mulleri</i> .....		×	×	Shallow sea, temperate zone (20).	11, 20
<i>C. aff. C. mulleri</i> .....		×		Fresh-water influence.	9
<i>C. politula</i> .....			×		22
<i>C. torosa</i> .....		×			5
<i>C. torosa var. litoralis</i> .....		×			13
<i>C. williamsoniana</i> .....		×	×		14
<i>Cytherideis</i> .....			×	Typical marine.	17
<i>C. unicornis</i> .....	×	×		Fresh or slightly brackish.	11
<i>C. unisulcata</i> .....	×	×		Fresh or slightly brackish.	11
<i>Cytheropteron</i> .....		×	×	Marine-brackish (3); typical marine (17).	3, 17
<i>C. sp.</i> .....		×		Marine or estuarine.	22
<i>C. elongata-concentricum</i> .....			×	Shallow water.	6
<i>C. virgineum</i> .....			×	Shallow sea, temperate zone.	20
<i>Cytherura</i> .....		×	×		16
<i>Darwinula leguminella</i> .....	×				1
<i>D. liassica</i> .....	×	×		Either fresh or brackish.	12
<i>Eucytherura</i> .....			×		17
<i>Herpetocypris aequalis</i> .....	×				7
<i>Krieh</i> .....			×	Shallow marine or estuarine.	7, 24
<i>Limnocythere zindorfi</i> .....	×	×			14
<i>Loxococoncha elliptica</i> .....		×			5
<i>Macrocypris horatiana</i> .....			×		22
<i>M. simplex</i> .....			×	Shallow water.	6
<i>Macrodentina</i> .....		×	×		10
<i>Nesidea</i> .....			×	Typical marine.	17
<i>Orthonotacythere</i> .....			×		15
<i>Paracypris</i> .....			×	Typical marine.	17
<i>Paracythere</i> .....			×	Typical marine.	17
<i>Pseudocythere</i> .....			×	Typical marine.	17
<i>Rhinocypris scabra var. hamata</i> .....	×				22
<i>Scabriculocypris acanthoides</i> .....	×				22
<i>S. cerastes</i> .....	×				22
<i>S. trapezoides</i> .....	×				22
<i>Schlerochylus</i> .....			×	Shallow lagoon, approaching littoral.	24
<i>Thaumatocypris bettenstaedti</i> .....			×	Up to 200 meters deep.	2
<i>T. feifeli</i> .....			×	Shallow water.	2

## LITERATURE CITED

- (1) ANDERSON, F. W. *Phasal deposition in the middle Purbeck beds of Dorset*. Ann. Rep. Brit. Assoc. Adv. Sci. **99** (for 1931): 378-380. 1932.
- (2) BARTENSTEIN, HELMUTH. *Thaumatocypris bettenstaedti n. sp. aus dem nordwestdeutschen Lias zeta*. Senckenbergiana **30**: 95-98. 1949.
- (3) BÖHL, ALBERT. *Beitrag zur Stratigraphie und Paleontologie der Tertiären Ablagerungen in östlichen Mainzer Becken*. Abh. Senckenb. naturf. Ges. **41**: 65-113. 1928.
- (4) BOSQUET, J. A. H. *Description des entomostacés fossiles des terrains tertiaires de la France et de la Belgique*. Mém. Cour. et Sav. Étrang. Acad. Roy. Belg. **24** (pt. 3) 142 pp. 1852.
- (5) BRADY, G. S.; CROSSKEY, H. W.; and ROBERTSON, DAVID. *A monograph of the post-Tertiary Entomostraca of Scotland (including species from England and Ireland)*. Paleontogr. Soc. London: 232 pp., 15 pls. 1874.
- (6) CHAPMAN, FREDERICK. *Foraminifera and Ostracoda from the Cretaceous of East Pon-*

- doland, S. Africa. Ann. South African Mus. 4: 221-237. 1904.
- (7) ———. Report on samples of surface Tertiary rocks and a bore sample containing Ostracoda from Queensland. Proc. Roy. Soc. Queensland 46 (6): 66-71. 1935.
- (8) CORNUEL, J. Description des nouveaux fossiles microscopiques du terrain inférieur du département de la Haute-Marne. Mém. Soc. Géol. France, sér. 2, 3 (pt. 1): 241-246. 1848.
- (9) GRILL, R. VON. Mikropaläontologie und Stratigraphie in dem Tertiären Becken und der Flyschzone von Österreich. Proc. 18th Int. Geol. Congr. Pal. Union for 1948, pt. 15: 51-60. 1950.
- (10) HILTERMANN, HEINRICH. Klassifikation der natürlichen Brackwasser. Erdöl und Kohle, Jahrg 2 (1): 4-8, 8 figs. 1949.
- (11) JONES, T. R. Notes on the Entomostraca. In E. Forbes' "On the Tertiary Fluvio-marine Formation of the Isle of Wight." Mem. Great Britain Geol. Surv.: 157-158. 1856.
- (12) ———. On the Rhaetic and some Liassic Ostracoda of Britain. Quart. Journ. Geol. Soc. London 50: 156-169. 1894.
- (13) KAPTARENKO-CHERNOUSOVA, O. K. Upper Tertiary microfauna of the Nicopol manganese ore district (Ukraine). Journ. Geol. (Acad. Sci. Ukr. SSR. Inst. Geol.) 6 (1-2): 199-223. 1939. [In Russian; English summary, pp. 221-223.]
- (14) LIENENKLAUS, E. Die Ostracoden des Mainzer Tertiärbekens. Ber. Senckenb. naturf. Ges. 2: 3-70. 1905.
- (15) MARTIN, G. P. Ostracoden des norddeutschen Purbeck und Wealden. Senckenbergiana 22 (5-6): 275-361. 1940.
- (16) MÉHES, GYULA. Die eozänen Ostracoden der Umgebung von Budapest. Geologica Hungarica, ser. pal., 12: 3-56. 1936.
- (17) ———. Die ostracoden der Oberoligozäns der Umgebung von Budapest. Geologica Hungarica, ser. pal., 16: 95 pp. 1941.
- (18) MOREMAN, W. L. Fossil zones of the Eagle Ford of north Texas. Journ. Pal. 1: 89-101. 1927.
- (19) MUNTHE, H. Studier af ner Gotlands senquartare historia. Sver. Geol. Unders., ser. Ca, no. 4: 213 pp. 1910. [English summary, pp. 181-206.]
- (20) STADNICHENKO, M. M. The Foraminifera and Ostracoda of the Marine Yegua of the type sections. Journ. Pal. 1: 221-243. 1927.
- (21) STEPHENSON, M. B. Miocene and Pliocene Ostracoda of the genus Cytheridea from Florida. Journ. Pal. 12: 127-148. 1938.
- (22) SYLVESTER-BRADLEY, P. C. The Purbeck beds of Swindon. Proc. Geologists' Assoc. London 51 (pt. 4): 349-372. 1940.
- (23) TERQUEM, OLYR. Les foraminifères et les ostracodes du Fuller's earth des environs de Varsovie. Mém. Soc. Géol. France, sér. 3, 4: 91-107. 1886.
- (24) ZALANYI, B. Biosociologische Zusammenhänge im Neogenbecken des grossen Ungarischen Tiefebene. Jahrb. Ungar. Geol. Anst., 1933-35, 4: 1621-1699. 1940.

BOTANY.—Peter Wilhelm Lund's pequi tree at Lagoa Santa and pilgrimages to his cemetery.<sup>1</sup> ANNA E. JENKINS, U. S. Department of Agriculture, A. A. BITANCOURT, Instituto Biologico, São Paulo, K. SILBERSCHMIDT, Instituto Biologico, and W. ANDREW ARCHER, U. S. Department of Agriculture.<sup>2</sup>

"Trees by their very nature are landmarks and memorials. They are therefore identified with human happenings. Also, trees, having more than the allotted span of

man, carry their associations through generations of men and women. Thus they often figure not only in biography but also in

<sup>1</sup> Among the desiderata we assembled mostly in 1941 for the preparation of this article is a letter (Dec. 6, 1941) from James A. G. Rehn, corresponding secretary of the Academy of Natural Sciences of Philadelphia, in which he wrote as follows: "I have your letter of the 3rd about Peter Lund, whose name of course was reasonably familiar to me on account of his work on the fossil deposits at Lagoa Santa. He was elected a Correspondent of our Academy January 29, 1850, and our records give his death as having occurred May 25, 1880. Correspondents of the Academy are elected from scientists non-residents of Philadelphia, who have achieved outstanding distinction in work in the natural sciences. A very considerable part of all the great workers in our field in the last century and a quarter were Correspondents of the Academy, although the number in this class at any one time is naturally limited, and rarely has ex-

ceeded 150." This article therefore commemorates the centenary of Dr. Lund's election as a Corresponding Member of the Academy of Natural Sciences of Philadelphia.

We are indebted to Dr. Elisabeth Deichmann, Museum of Comparative Zoology, Harvard University, for a critical reading of the manuscript.

Miss Deichmann's mother was P. W. Lund's grand-niece. She was 11 years old when he died, but her whole childhood was flavored by stories about this distant uncle who kept up the contact with his family in Denmark until his death.

<sup>2</sup> In 1935-36 the first writer was on a mycological mission to Brazil, at the invitation of the government of the State of São Paulo, and was working cooperatively with the second writer at the Instituto Biologico. The fourth writer was completing a plant exploration mission to South America.



history." So wrote Randall and Edgerton (16)<sup>3</sup> in their *Famous trees*.

Of trees associated with "notable persons, events, and places" is the beautiful pequi (*Caryocar brasiliense* Camb.)<sup>4</sup> growing beside the tomb of Peter Wilhelm Lund (1801-1880)<sup>5</sup> at Lagoa Santa, Minas Gerais, Brazil. The actual existence of this tree and its rôle in the life of this noted Danish scientist may well have been disclosed to many readers only through brief mention of it in one or another of Prof. Anibal Mattos compilations of 1935 (9-12). These mark the centenary celebration of the savant's arrival at Lagoa Santa. In 1930 the original tomb had been replaced by a monument "which would signify the gratitude of the people of Minas for the valuable works of the great scientist." This was erected under Professor Mattos' direction at the commission of the governor of the State.

In his address at the unveiling of the new

<sup>3</sup> Reference is made by number (italic) to Literature cited, p. 74.

<sup>4</sup> Described in Saint-Hilaire (18, p. 322, pl. 67 bis). The illustration is reproduced in Jenkins' "Introductory Essay" accompanying Saint-Hilaire's "Esquisse de mes Voyages au Brésil et Paraguay" (20, fig. 4).

<sup>5</sup> For an extended biography of Lund cf. Reinhardt (17). A brief obituary notice (1) is quoted below:

"On May 25th died, at Lagoa Santa, in Brazil, the Danish philosopher and zoologist, Dr. P. V. Lund, aged nearly 79. Born in Copenhagen he graduated at the Copenhagen University, and was intended for the medical profession. He was soon diverted from this pursuit, however, by his interest for natural science, and when, in 1825, he gained a double golden medal for some zoological prize essays, he made a definite choice between the two. Ill health made him seek a milder climate in South America; and after a short stay in Rio Janeiro he returned to Europe, travelled to Italy with J. F. Schouw, the Danish botanist, and Mr. Harewood, and spent some years in France, where he became a friend of Cuvier. In 1832 he went out again to Brazil, and thenceforward lived in the small town of Lagoa Santa, in the province of Minas Gerais. The remarkable caves near this place, containing fossil remains of the Brazilian fauna from the Tertiary period, were discovered by Dr. Lund; and the paleontological collections he made in them were presented by him in 1854 to the Danish State, and now form a separate and much appreciated section of the Zoological Museum of Copenhagen.

"Dr. Lund also transmitted to Copenhagen many specimens of birds from the vicinity of Lagoa Santa. Prof. Reinhardt's well-known essay on the bird-fauna of the Campos of Brazil was based mainly upon Lund's collections." (Cf. also Pinto, 15.)

monument to Lund, the representative of Denmark stated that the site of the monument is the same as that acquired by the savant and that the parcel of cerrado<sup>6</sup> is entirely enclosed (11, p. 22). "At one side of the monument," he continued, "is the 'frondoso pequi' under the shade of which the scientist used to study." Mattos (11, p. 28) wrote that during the course of its construction a vase of flowers and a branch of the pequi were deposited in the tomb by Sra. Carlos Correa and Sra. Mattos. Because of its location and its low, broad head, the tree forms an important part of the composition in two of Mattos' photographs taken within the cemetery (9, opposite p. 57, also reproduced in 10, opposite p. 32; 9, opposite p. 80).

Our introduction to the pequi by Lund's monument was in 1936, when we were privileged to make a pilgrimage to his grave.

As guests of Dr. José de Mello Soares de Gouvea, director of the Department of Agriculture of Minas Gerais, the first three of the writers made the tour from Belo Horizonte on February 2. We had attended the "First Meeting of the Plant Pathologists of Brazil" held in Rio January 20-25, then visited the Escola Superior de Agricultura at Viçosa,<sup>7</sup> Minas, and were returning to Rio and São Paulo, via Belo Horizonte. The fourth writer's pilgrimage to the cemetery was made on August 3, as the guest of Dr. Henrique L. de Mello Barreto, botanist of the State Agricultural Department.<sup>8</sup>

As an introduction to Lagoa Santa we are here quoting from the preface of Warming's (22, p. 455) *Lagoa Santa*, as well as reproducing the map (Fig. 1) there cited.

Lagoa Santa est un petit village de l'état brésilien de Minas gérães. Il est situé à 19° 40' de latitude Sud, au Nord-Nord-Ouest de Rio de Janeiro (voir la vignette du titre et la carte p. 267). C'est là qu'habitait, depuis 1835 jusqu'en 1880, année de sa mort, le zoologiste et paléontologue

<sup>6</sup> A recent description of "campo cerrado" is that by Bezerra dos Santos (2, pp. 141-144).

<sup>7</sup> Our host on this occasion was Prof. A. S. Muller, then plant pathologist and acting director of the Escola, now on the staff of the Escuela Agrícola Panamericana at Tegucigalpa, Honduras.

<sup>8</sup> We are pleased to express our thanks and appreciation to Dr. Soares de Gouvea and to Dr. Mello Barreto for the hospitality they so generously extended.

danois très connu, P. W. Lund, et c'est de là qu'il dirigeait la publication de ses belles et fort importantes recherches sur les animaux fossiles des cavernes calcaires du Brésil (comp. l'index bibliographique). Lagoa Santa fut visité trois fois par le zoologiste danois, M. le Prof. Joh. Reinhardt, qui y passait chaque fois un temps assez long. Moi-même, étudiant, au début de mes études de botanique,—il y aura bientôt trente ans.—j'y ai vécu, dans la maison de Lund, trois belles années de ma jeunesse (1863-1866). Je rappelle ma jeunesse afin qu'on veuille bien ne pas coter trop haut les imperfections des observations que j'ai faites et que je communique dans ce mémoire. Lagoa Santa fut visité également par plusieurs autres explorateurs et savants, venus notamment pour voir Lund et lui rendre visite (v. p. 162), de sorte que ce misérable hameau est devenu en quelque sorte un endroit classique dans l'histoire des sciences.

On February 2, upon reaching the outskirts of Lagoa Santa, our host halted a few moments in order that we might view the lake for which the hamlet is named (Fig. 2, A) and concerning which there are so many legends (cf. 10, pp. 19-25).

The story of Lund's taking up his abode in Lagoa Santa and of his owning a piece of

cerrado in the neighborhood was recounted by Mrs. Agnes Chase (5) following her pilgrimage to the old tomb. "A few hours north of Bello Horizonte is Lagoa Santa," she began, and continued:

Lund was a consumptive who went to Brazil [1825] for his health. After a few years he returned to Denmark cured, but the disease again attacked him and he returned to Lagoa Santa to die. Being a Protestant he could not be buried in the cemetery, so he bought a piece of ground about 5 kilometers from the village for his grave. He lived 40 years after that, and buried Clausen,<sup>9</sup> and another friend and his two Danish servants in his little cemetery before he himself was buried there in 1880 at the age of 79. The few acres inclosed form a precious preserve of the original campo. Except for four immense clumps

<sup>9</sup> Lund's three secretaries were the Norwegian Brandt, his own countryman Warming, and the German Berens, and Brandt and Behrens were buried in Lund's cemetery (9, p. 91). Clausen returned to Europe and died in London in 1855 (cf. 21, p. 11). We are making this correction here at Mrs. Chase's suggestion. The names were not clear on the old tomb, she explained to us, and she understood that Clausen was buried in Lund's plot.

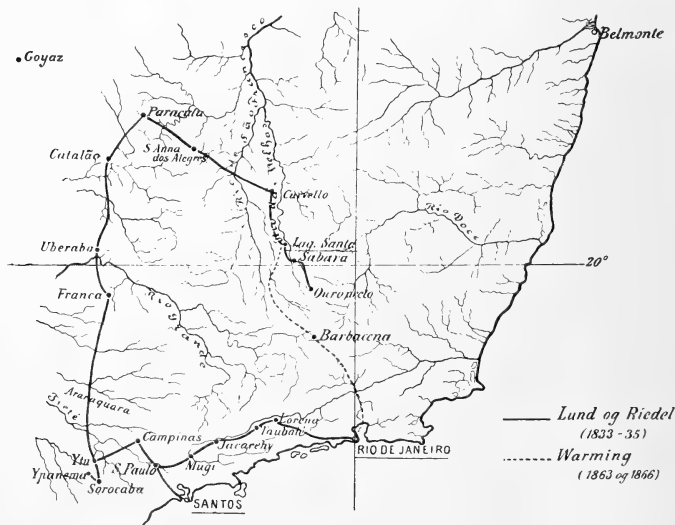

FIG. 1.—Location of Lagoa Santa as shown on Dr. Eugene Warming's map accompanying his *Lagoa Santa* (22, p. 267; 23, p. 101).

of bamboo, the ground is left wild—the best kind of memorial to Pedro Lund. He was dearly loved by the Brazilians, and women still come to the cross to pray for the soul of the Protestante.

In further detail of her visit to the old tomb on March 25, 1926, Mrs. Chase has told us that fresh flowers, then wilted, had been placed at the foot of the cross. Her photograph (5, pl. 8, fig. 2) shows the cross in its position outside the "Campo Santo" as one author (9, p. 53) referred to the old cemetery. In the new enclosure the cross stands in line with the tombs of Lund and

his assistants and to the rear (see Fig. 3, B). Painted black, it is of "aroeira" (mastic-tree) and has the date of Brandt's death, "1862," engraved on it, as Dr. Mello Barreto has informed us.

At the cemetery one not only pays homage to Peter Lund and his beloved assistants, but he at once senses that the pequi growing so near the plot selected by the naturalist for his grave must have been an intimate tree-friend. Breaking the silence as if reading our thoughts our host said, "Lund used to sit under that tree while engaged in study."

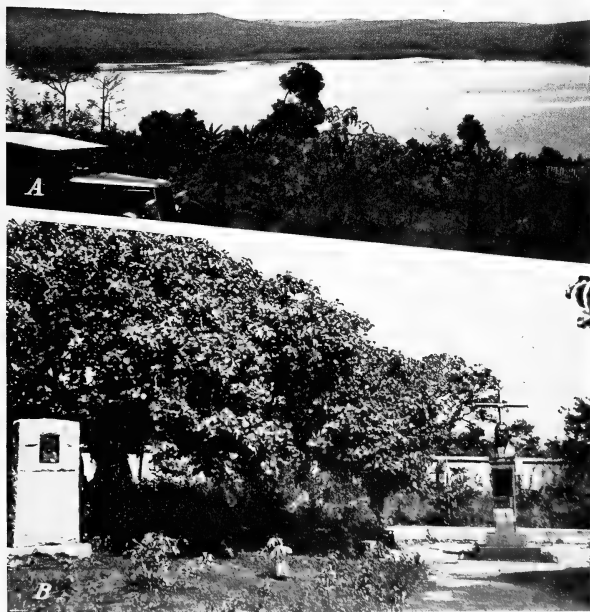

FIG. 2.—A, The lake at Lagoa Santa. B, The cemetery of Dr. Peter Wilhelm Lund; at right, monument surmounted by a bronze bust of the savant; in left foreground, Warming memorial; at left, the pequi. Photographs by Bitancourt, February 2, 1936.

The tree was in full leaf on February 2 (Fig. 2, B). On August 3, however, it was completely defoliated, with the recently dropped leaves lying on the ground below. In describing the vegetation of Lagoa Santa in spring (August-October), Warming (23, p. 228)<sup>10</sup> mentioned *Caryocar brasiliense* as one of the trees that drop all their leaves, then immediately leaf out.

Lund's pequi was conforming to this pattern when the fourth writer saw it on August 3. He painstakingly oriented his camera to include as much as possible of the pequi's odd, tortuous frame (Fig. 3, A).<sup>11</sup> He noted, too, the deeply furrowed bark, less well shown in the photograph. It so happens that the head of another bare pequi forms the background in his photograph of the monument to Lund (Fig. 3, B). In its defoliation this tree exposes a few epiphytes.

In Mrs. Chase's photograph of the old tomb (5) taken on March 25, 1926, the tree is in its usual luxuriant foliage casting a heavy shadow on the ground beneath. In Mattos' corresponding illustration the pequi is leafless. In both cases it is shown only in part, at the left, and the legends refer only to the tomb.

References to the tree in the legends accompanying Mattos' illustrations of the new cemetery are as follows: "Visto do velho pequi a cuja sombra estudava o sabio dr. Lund" (9, opposite p. 57); "Herma do dr.

<sup>10</sup> During his visit to Belo Horizonte, the fourth writer was presented with a copy of Lofgren's translation into Portuguese of Warming's *Lagoa Santa* (23). This volume, now catalogued in the Library, U. S. Department of Agriculture, has been a ready reference in the preparation of the present article.

<sup>11</sup> The monument to Warming shown in the left of this photograph was erected in 1934, through the inspiration of Dr. Paulo Campos Porto, by the Jardim Botânico, Rio de Janeiro. Its execution was aided by the Secretary of Agriculture of the State of Minas Gerais. The inscription on the monument is as follows:

ALTERI EGREGIO DANO NATURAE INDAGATORI  
JOANNI EUGENIO WARMING  
DVI DOCTORI LUND AD LACUM SANCTUM CONVICTOR  
FLORAM AD BRASILIANAM PENITUS SCRUTATUS  
OECOLOGIAE BOTANICAE EXSTITIT FUNDATOR  
IN PERENNEM MERITI MEMORIAM  
POSTRIDIE NONAS JULIAS  
A. D. MCMXXXII  
HORTI BOTANICI  
AD  
RIO DE JANEIRO  
RECTORES

Lund vendo-se ao fundo pequizeiro por elle plantado . . ." (10, opposite p. 32), and "O pequizeiro plantado pelo dr. Lund . . ." (11, opposite p. 80).

Our hosts of 1936 have assured us that the first of these legends, as just quoted, is the correct one. The pequi is a common plant of the cerrado, they remind us, and is very slow-growing. Substantiating the latter statement our colleague Dr. A. O. Drummond<sup>12</sup> wrote us in 1946 that his 6-year-old pequi at Viçosa was then only 70 cm high.

Warming (23, p. 62) named the pequi among trees of the cerrado of Lagoa Santa having an orchard-tree-like habit and attaining a height of 3-6 meters. It is perhaps the comparatively low stature coupled with the many-leaved, far-extending branches, that imparts to Lund's pequi its unforgettable aspect. The pequi of the cerrado of Mogy-Mirim, São Paulo, illustrated by Hoehne (8, p. 86) is more erect and apparently taller. Dr. Mello Barreto tells us that he has seen pequizeiros 10 meters high and that Riedel cited examples reaching 13 meters.

Still another illustration of the pequi tree<sup>13</sup> has the following informative legend:

The 'pequi' tree—*Caryocar Brasiliense* Camb. One of the many fruit-bearing trees of the cerrado of Brazil, which in its habit shows us what nature proportions to plants subject to incessant, harmful fires. Their fruits are, however, most useful and are the base of various drinks and condiments [translation].<sup>14</sup>

Dr. Drummond's letter already cited contains the following observations relative to pequi fruit: "In localities where the tree is native its fruit is much appreciated by the inhabitants; it does not appeal to those unaccustomed to its wild flavor. The seed is covered with small spines, which are easily freed and which pierce the tongue slightly. A dentist told me that when he lived at Cardisburgo, a small village in the cerrados

<sup>12</sup> Formerly on the staff of the Escola Superior de Agricultura de Minas Gerais, now of the Serviço Publico do Estado de Minas Gerais, Belo Horizonte.

<sup>13</sup> Arq. Bot. Estado São Paulo, n. s., 1 (5). 1943.

<sup>14</sup> For further information on the uses of the pequi in Brazil cf. Corrêa (7), Pereira (14), Netto (13), and others.

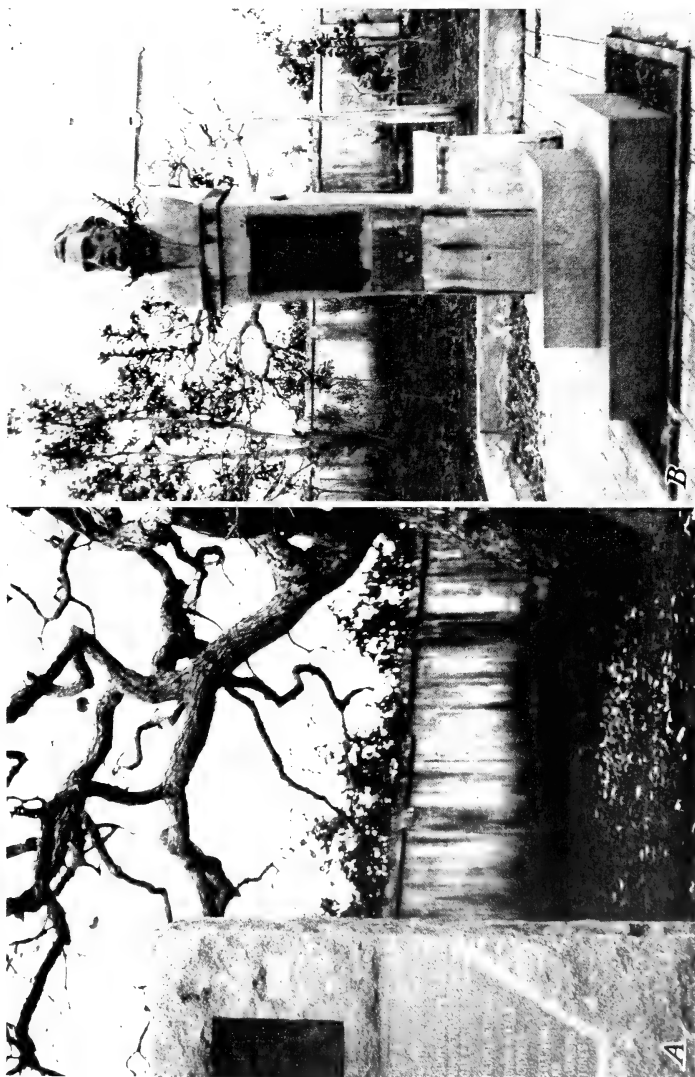

FIG. 3. Close views of the several monuments, August 3, 1936, showing (A) Lund's pequi, leafless, together with another leafless pequi outside the enclosure (B). Photographs by Archer.

near the famous Maquiné Caves, the main job he had was to remove the pequi spines from the tongues of the village children."

In his familiarity with the pequi that now grows beside his grave Dr. Lund must have known it in full leaf, almost momentarily leafless, in gorgeous flower, and then in fruit. The charm of the bloom is referred to by Chodat and Hassler (6, p. 809) in their account of the Caryocaraceae of Paraguay. To quote:

L'unique Caryocaracée trouvée au Paraguay est le *Caryocar brasiliense* un arbuste habitant les campos secs au pied et sur le haut plateau de la Sierra de Maracaya où il est assez répandu. Sa fleur aux nombreuses étamines d'une couleur jaune paille s'ouvrant à l'aube, donne un charme tout particulier aux Campos pendant les heures matinales.

The numerous stamens are well shown in the line-drawing accompanying the original description of the species (cf. footnote 4). Their conspicuousness is again apparent from the herbarium specimen considerably sent to us by Dr. Mello Barreto<sup>15</sup> (Fig. 4). Collected at Belo Horizonte, November 7, 1941, by J. Evangelista Oliveira 630, this has been deposited in the herbarium of the U. S. National Arboretum. The only other accessions of this species in that herbarium are two from Minas collected in 1914 by P. H. Dorsett (1862-1943), A.D. Shammel, and Wilson Popenoe, plant explorers of the U. S. Department of Agriculture. The first specimen from Lavras, January 14, consists of fruit, and a tomentose stem with leaves. The second specimen, from Januaria, February 14, is of fruit only and the collector's note reads: "The fruit is just commencing to ripen. The pulp surrounding the seed is yellow and has a peculiar taste." Their photograph (February 4) of "a large pequi growing beside the road to Lagoa Santa" is shown in Fig. 4. The tree is "very common throughout this region," they noted.

In 1938, upon discovering that *Caryocar brasiliense* was not represented in the U. S. National Herbarium, the present writers contributed their "souvenir" of a cluster of the young, silken, 3-parted leaves from the tip of a branch of Lund's pequi, together

<sup>15</sup> Transmitted with his letter of November 11, 1941.

with a representative set of photographs taken in the cemetery on February 2, 1936. To these they added a view of the nearby cerrado. The fourth writer's specimen from a blooming tree at Mendenha, Minas, September 24, 1936, was deposited in the same herbarium as its second accession of *Caryocar brasiliense*. This specimen is complete with fruit. We are gratified to note that more recently our small sample from Lund's tree has been supplemented by an ample specimen from a tree in flower at Lagoa Santa (U. S. Nat. Herb. no. 1933005). The descriptive label reads: "*Caryocar brasiliense* Camb. Tree 2-10 m. Flowers white. 'Pequi,' fruit edible, has a hard exocarp. The fruit is the yellow pulp around the spiny seed. Important tree in cerrado. In campo cerrado, near Lagoa Santa airfield.<sup>16</sup> Municipio of Lagoa Santa, alt. 850-900 m. Louis O. Williams, Vicente Assis, No. 7441. Sept. 10, 1945."

In response to our inquiry of 1941 we learned from Dr. Lyman B. Smith<sup>17</sup> that there were then three sheets of the *Caryocar* in the Gray Herbarium. All three specimens are historical, the earliest especially so because it was collected by Lund's countryman Claussen, who as circumstances willed, was responsible for Lund's having become the "founder of paleontology" in Minas Gerais (4) or as it is sometimes stated, "father of Brazilian paleontology" (9, p. 53; 10, p. 307). As cited by Dr. Smith the three specimens are:

Claussen, without number, Minas Gerais, 1840.  
Widgren, without number, Minas Gerais, 1845.  
Dusen, No. 15968, Jaguarahyva, Paraná, 1914.

Claussen's specimen could well have been collected from a pequi on his fazenda "Porteirinhas" near Curvello (see map, Fig. 1). It was upon Lund and Riedel's arrival at Curvello in 1834 that the "adventurer" (cf.

<sup>16</sup> For comparison with air travel to Lagoa Santa today, we cannot refrain from quoting here Warming's (23, p. 10) passage depicting his journey from Rio to Lagoa Santa (1863): "I left the 28th of May with the party of a farmer from the neighborhood of Lagoa Santa and, after 42 days' travel, glimpsed for the first time that unforgettable little place . . . [translation]."

<sup>17</sup> Then on the staff of the Gray Herbarium, Harvard University, now on that of the Department of Botany, U. S. National Museum.



FIG. 4.—Pequi growing beside the road to Lagoa Santa, Brazil, February 4, 1914, Dr. Popenoe posing in foreground. Photograph by Dorsett, contributed by the Division of Plant Exploration and Introduction, U. S. Department of Agriculture.

9, p. 9) Claussen encountered the two scientific travellers, thereupon inviting them to his fazenda, where they spent a week. This unanticipated visit led to Lund's becoming acquainted with the fossil-containing calcareous caves of the region (cf. 23, p. 9). Our excursion to Lagoa Santa on February 2 included a visit to a nearby cave explored by Lund, namely, Lapinha Cave.

The specimen collected by Dusén (1856–1926) at Jaguarihyva is, of course, from the same locality where Saint-Hilaire discovered the pequi growing and in bloom (February 5) in 1820 (19, vol. 2, p. 50).<sup>18</sup> Neither record is cited in Hoehne's (8, 1930, p. 48) discussion of the cerrados of Jaguarihyva.

<sup>18</sup> The specimens on which Cambessedes [see footnote 1] description of *Caryocar brasiliense* is based were collected by Saint-Hilaire (1779–1851) "in campis prope S. Bento, in parte occidentali desertaque provinciae Minas Gerais, et Franca [see map, Fig. 1], urbem provinciae S. Paulo."

Our host of February 2 has told us that because of the botanical pursuits of Lund, Warming, and others at Lagoa Santa, this is the type locality of many different plants of the cerrado. "In consequence," he continued, "botanists come from far and near to re-discover, observe, and collect these same species."

Almost as he spoke, we noted the typical symptoms that follow infection by *Sphaeceloma* on leaves of *Byrsonima coccolobaefolia* H. B. K. (Malpighiaceae) growing naturally in a small space before the cemetery. Journeying to Belo Horizonte soon afterward our colleague Dr. H. P. Krug<sup>19</sup> took advantage of the opportunity also to visit Lund's cemetery and again to collect material of the *Sphaeceloma*. These specimens of February 2 and April 8, together with a

<sup>19</sup> Then plant pathologist at the Instituto Agronomico, Campinas, State of São Paulo, now on the staff of the Horto Florestal, Cantareira, State of São Paulo.

culture isolated from one of them, served as the basis of the description of a new pathogenic fungus, named for the locality, i.e., *S. lagoa-santensis* Bitancourt and Jenkins (3, p. 152, pl. 1).

The "Introduction" to Warming's (23, p. 17) classic *Lagoa Santa* closes with the following sentence: "When Lund, after visiting Claussen, was accompanying his companion Riedel to the capital of Minas, Ouro Preto, situated a few leagues to the south-east of Lagoa Santa, the lovely lake with its enchanting neighborhood so impressed him that, having traversed the desert regions of the interior, he involuntarily exclaimed: 'Here indeed: here is a good place for one to live,' perhaps foreseeing that he was to live there for almost half a century and to find his final resting place in the shade of the trees of the campo [translation]."

The ancient pequi near the grave of Lund seems to assume the personality of a kindly sentinel, standing silent, protective, and serene.

#### LITERATURE CITED

- (1) ANONYMOUS. *Obituary* [Peter Wilhelm Lund]. *Ibis*, ser. 4, 4: 483-484. 1880.
- (2) BEZERRA DOS SANTOS, L. *People and scenes of Brazil: Excerpts from the "Revista Brasileira de Geografia"*: 160 pp. [Translated by Adrian Rondileau.] In Conselho Nacional de Geografia. Rio de Janeiro, 1945.
- (3) BITANCOURT, A. A., and JENKINS, ANNA E. *New discoveries of Myriangiales in the Americas*. Proc. 8th Amer. Sci. Congr., Washington, 1940, 3: 149-172. 1942.
- (4) CALOGERAS, J. D. *O Dr. Peter Wilhelm Lund*. Rev. Inst. Hist. Geogr. Bras. Volume especial: 83-93. Rio de Janeiro, 1933.
- (5) CHASE, AGNES. *Eastern Brazil through an agrostologist's spectacles*. Ann. Rep. Smithsonian Inst. for 1926: 383-403. 1927.
- (6) CHODAT, E., and HASSLER, E. *Plantae Hasslerianae*. . . Bull. Herb. Boiss., sér. 2, 3: 809. 1903.
- (7) CORRÊA, M. P. *Flora do Brasil: Algumas plantas úteis, suas aplicações e distribuição geográfica*: 154 pp. Rio de Janeiro, 1909.
- (8) HOEHNE, F. C. *Araucarilandia*, 133 pp., 1930; *Excursão*. . . São Paulo. . . 112 pp., undated. São Paulo, Secretaria da Agr., Indus., e Com., Dept. Bot. do Estado, Observações. . . Brasil 2 and 3.
- (9) MATTOS, A. *O sabio dr. Lund e a prehistoria Americana*, ed. 3: 92 pp. Belo Horizonte, 1935.
- (10) ———. *O sabio dr. Lund e estudos sobre a pre-historia brasileira*: 346 pp. Belo Horizonte, 1935.
- (11) ———. *Collectanea Peter W. Lund*: 268 pp. Belo Horizonte, 1935.
- (12) ———. *Monumentos historicos, artisticos, e religiosos de Minas Gerais*: 502 pp. Belo Horizonte, 1935.
- (13) NETTO, F. F. *The problem of the Amazon*. *Sci Monthly* 61: 33-44, 90-100. 1945. [Translated by W. A. Archer with translator's note, p. 38.]
- (14) PEREIRA, H. *Apontamentos sobre madeiras do estado de S. Paulo*: 160 pp. São Paulo, 1919.
- (15) PINTO, O. *Peter W. Lund e sua contribuição a ornitologia brasileira*. Papéis Avulsos Dept. Zool. Secretaria Agr. S. Paulo. 9: 269-283. 1950.
- (16) RANDALL, C. E., and EDGERTON, D. P. *Famous trees*. U. S. Dept. Agr. Misc. Publ. 295: 115 pp. 1938.
- (17) REINHARDT, J. *Naturforskeren Peter Wilhelm Lund*. . . Overs. Danske Vid. Selsk. Forh. 1880: 147-210. 1880.
- (18) SAINT-HILAIRE, A. DE. *Flora Brasiliae Meridionalis* 1: 322. 1825.
- (19) ———. *Voyage dans les provinces de Saint-Paul et de Sainte-Catherine*, 2 vols. Paris, 1851.
- (20) ———. *Esquisse de mes voyages au Brésil et Paraguay*. . . Reprinted in *Chron. Bot.* 5 (1): 61 pp. 1946.
- (21) URBAN, I. *Claussen Peter* (flor. 1834-1850). In Martius, C. F. A., *Flora Brasiliensis* 1 (1): 11-13. 1906.
- (22) WARMING, E. *Lagoa Santa*. . . : 488 pp. Copenhagen, 1892.
- (23) ———. *Lagoa Santa* (tradução do Dinamarca por Alberto Lofgren): 282 pp. Belo Horizonte, 1908.



ZOOLOGY.—*Notes on the undescribed males of two species of Copepoda*. S. KRISHNASWAMY, Madras University. (Communicated by Paul L. Illg.)

In the course of a study of the Copepoda of the Madras coast, males belonging to two species, *Centropages trispinosus* Sewell (1914) and *Diosaccus truncatus* Gurney (1927), known so far only by the females, were discovered. A full description of these male types is given in this paper so as to complete the identification of the species. The types will be lodged in the Indian Museum at Calcutta.

I wish to record my grateful thanks to Dr. C. P. Gnanamuthu, director, Zoology Laboratory, Madras University, for guidance and help and to Lt. Col. R. B. Seymour Sewell, of Cambridge, for going through the paper and offering helpful criticisms.

#### *Centropages trispinosus* Sewell

Fig. 1, a-d

*Centropages trispinosus* Sewell, 1914, p. 223, pl. 23, figs. 5-8.

This species was established by Sewell in 1914, on the basis of a solitary female taken at Kilakarai in the Gulf of Manaar, South India, and has not until now been recorded since. While examining the plankton collected in July 1937 from Krusadai Island in the Gulf of Manaar I found several females and males. Large numbers were also found in the inshore plankton collected at Madras in July, August, September, and January.

Sewell (loc. cit.: pl. 18, fig. 7) has given the figure of the second swimming leg and is of opinion that the remaining legs resemble those of *C. alcocki* Sewell. The first swimming leg, however, differs from the second one and has the following structure: The exopodite is nearly twice the length of the endopodite. The first exopod joint carries one outer spine and one inner seta, the second joint one outer spine and one inner seta, and the terminal joint two outer spines, one long, finely serrate apical spine, and four inner setae. The first endopod joint has an inner seta, the second joint two inner setae, and the terminal joint five setae. The outer margins of the exopod as well as the endopod of the swimming feet are hirsute.

The description of the female holotype given by Sewell is fully corroborated by my observations of a large number of females except for the difference stated above.

*Male* (Fig. 1, a).—1.025 mm, smaller than the female.

Body yellowish red with dark red patches on the cephalothorax. A bright-red spot is present on the anal segment. Outline of body with the three spines on posterior corner of cephalothorax as in the female. The abdomen is 4-jointed, whereas in the female it is only 3-jointed.

The right antennule is geniculate and composed of 21 joints, having the following proportional lengths:

1.2.3.4.5.6.7.8.9.10.11.12.13.14.15.16.17.18.19.20.21.  
11.9.3.4.6.5.4.5.6. 6. 4. 9.12.16.13.16.15.30.35.15.25.

Seven of these joints (i.e., from the twelfth to the eighteenth) are very swollen. All the joints carry one or two setae each toward the outer side. These setae are short and thick, except those on joints 19, 20, and 21, which are long. The eighteenth joint is hinged to the nineteenth, and these joints each have a toothed plate toward the outer side. The inner distal end of the nineteenth joint has a protuberance, whereas the terminal joint is produced into a fingerlike process. The number of setae and their arrangement are as shown in Fig. 1, b. The antenna, mandible, maxillae, and maxilliped are as in the female. The first four pairs of swimming feet as in the female.

The fifth leg of the left side differs from those of the other species of the genus. The exopod is of two joints, the proximal joint has an outer spine, while the distal joint, which is nearly twice as long as the first joint, bears two outer and two apical spines, the outer ones being longer. The endopod is 3-articled and is shorter than the exopod. The first and second joints carry a plumose seta each, while the third has two inner, two outer, and two apical plumose setae (Fig. 1, c). The exopod of right fifth leg resembles those of the other members of the genus. The first joint bears a short outer spine, and the "chela" bears two spines one toward the outer side and one toward the inner side, and the outer margin is hirsute. The endopod is 3-jointed, and the first and second joints carry a plumose seta each, the third joint three inner, two apical, and one outer plumose seta (Fig. 1, d).

*Remarks*.—The presence of the spines on the posterior end of the cephalothorax is a distinct

feature that facilitates the identification of this species. The occurrence of this species at Madras is of interest because it was previously known only from Kilakarai, 300 miles south of Madras.

**Diosaccus truncatus** Gurney

Fig. 2, a-d

*Diosaccus truncatus* Gurney, 1927, p. 513, fig. 136; Sewell, 1940, p. 240.

Gurney described this harpacticoid in 1927 from the females collected by him at Port Said. In the Madras plankton collected on February 21 and 22, 1949, four males and two females were found. A night haul made at Kundugal channel (Gulf of Manaar) on March 22, 1948, yielded four males.

*Male*.—0.68 mm, distinctly shorter than the female, which measures 0.9 mm.

The rostrum is triangular and mobile. The second, third, and fourth thoracic segments have their lateral margins produced externally into winglike expansion. The abdomen is 4-jointed. The caudal rami are longer than broad, and each ramus carries three spines and an apical jointed seta, which is half as long as the body.

The antennules of the two sides are geniculate. Each antennule is 8-articled, the joints having the following proportional lengths:

1.	2.3	4.5	6.	7.8.
11.15.	5.	15.10.	10.8.	

The line of demarcation between the third and fourth joint is not clear. The fifth joint is very swollen and has a knoblike projection towards its proximal side. It carries an "aesthete" on its distal end. The sixth and seventh joints are hinged and

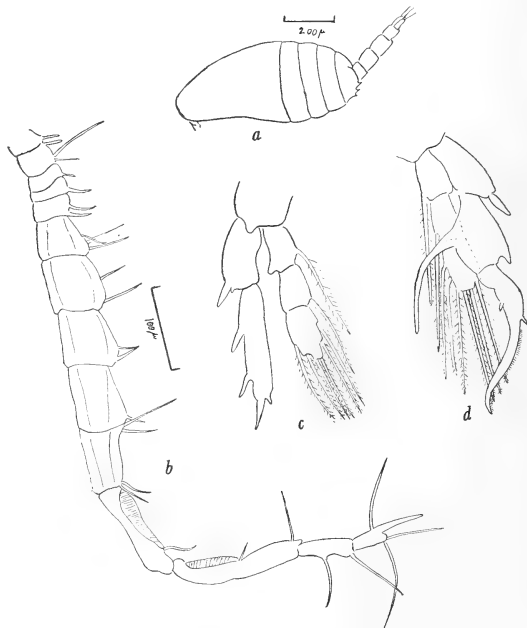

FIG. 1.—*Centropages trispinosus* Sewell: a, Lateral view; b, right antennule (from the seventh joint); c, fifth leg (left side); d, fifth leg (right side).

are armed with fine teeth on their inner edges. The arrangement of the setae is as shown in Fig. 2, *b*. The antenna, mouth parts, and the first swimming feet as in the female. The second swimming leg differs from that of the female in the exopod and endopod being of three and two joints and not three and three joints as in the female. Further, the outer margins of the first joints of the exopod and endopod are hirsute. The first and second exopod joints carry a serrate spine each on the outer side, while the third joint has three serrate spines and three setae. The second exopod joint has two inner setae also. The first endopod joint has a seta toward the inner side, while the terminal joints carries two spines and two setae, two of which are modified (Fig. 2, *c*). The third and fourth swimming legs as in the female. Fifth leg has the basal expansion completely fused and

bears two unequal spines and three setae (Fig. 2, *d*:  $L_5$ ). Sixth leg is rudimentary and is represented by a stout spine and two setae (Fig. 2, *d*:  $L_6$ ).

*Remarks.*—The female of this species found at Madras is smaller in size compared with the form described by Gurney from Port Said. It is being recorded for the first time from the Bay of Bengal.

## REFERENCES

- GURNEY, R. *Report on Crustacea Copepoda*. Trans. Zool. Soc. London **22**: 451. 1927.  
 NICHOLLS, A. G. *A revision of the families Diosaccidae Sars and Laophontidae T. Scott*. Rec. South Australian Mus. **7**: 165. 1941.  
 SEWELL, R. B. S. *Notes on surface copepods of the Gulf of Mannar*. Spolia Zeylanica **9**: 191. 1914.  
 ———. *Copepods of the Indian seas: Calanoida*. Mem. Indian Mus. **10** (2). 1932.  
 ———. *Copepoda Harpacticoida*. John Murray Expedition Sci. Rep. **7** (2). 1940.

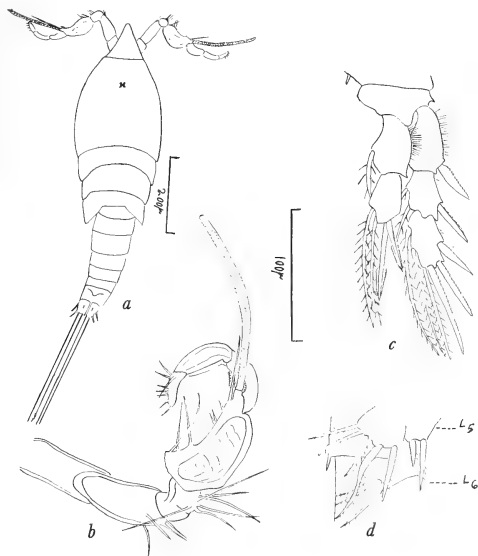

FIG. 2.—*Diosaccus truncatus* Gurney: *a*, Dorsal view; *b*, antennule; *c*, second swimming feet; *d*, fifth leg ( $L_5$ ), sixth leg ( $L_6$ ).

ZOOLOGY.—*New cleidogonid millipeds (Chordeumoidea)*. NELL B. CAUSEY, Fayetteville, Ark. (Communicated by H. F. Loomis.)

Their dark color, retiring habits, and small size make collection of cleidogonid millipeds difficult, but with patience they can be found in almost any damp humus in the Mississippi Valley, the states east of it, and in Central America. Inasmuch as species are rather endemic, doubtless numerous others are yet to be discovered. A key to the genera will be found in the survey of the Family Cleidogonidae by Hoffman (1950).

I am indebted to Dr. M. W. Sanderson for the opportunity of studying specimens of *Cleidogona fustis* Cook and Collins and the type specimens of *C. inflata* and *C. unita*, all of which are in the collection of the Illinois Natural History Survey. The type specimens of *C. minima*, *C. aspera*, *Ozarkogona glebosa*, and *Tiganogona moesta* will be deposited in the collection of the Academy of Natural Sciences of Philadelphia. Unless stated otherwise, collection was by the author.

*Cleidogona fustis* Cook and Collins

The two male specimens from Turkey Run State Park, Montgomery County Ind., are in the Illinois collection. This is the only published locality of this species.

*Cleidogona aspera*, n. sp.

Figs. 1-4

This species is near *C. laminata* Cook and Collins in the structure of the gonopods and in the modification of the legs of the male. The two species are separated by differences in the longest processes of the gonopods, which are fimbriate in *laminata* and bifid in *aspera*.

*Male holotype*.—Color brown above and laterally, with the usual areolate buff maculae; cream below; legs cream except the tarsi, which are brown; antennae and vertex of head brown; ocelli dark, forming a triangular patch, arranged in rows of 7, 6, 5, 3, 3, 2, 1.

The ninth legs are almost as in *laminata*; on the mesial surface of the first segment is a deep, rectangular depression, its laterad surface and the area immediately distad finely granular. The glandular openings on the first segments of the tenth and eleventh legs are as in *laminata*.

The sternal process at the base of the twelfth legs is distinctive in the shape of the spine (Fig. 1).

As in *laminata*, the ventral branch of each gonopod ends in three processes, the ventral one resembling the head of a bird, the longest one, unlike *laminata*, finely bifid distally, and the third and shortest one subquadrate and attached to the base of the longest process. The dorsal branch of each gonopod is somewhat flattened vertically; there is no notch on the medial face, as in *laminata*. Ventral, dorsal, and lateral views of the gonopods are shown in Figs. 2, 3, and 4, respectively.

*Length* about 20 mm, *width* 2.1 mm.

*Female paratype*.—Resembles the male in size and color; ocelli arranged in rows of 1, 7, 6, 5, 4, 3, 2.

*Type locality*.—Arkansas: Lawrence County, 6 miles east of Imboden on highway 62; 7 males and 7 females were collected from a dry oak-cedar area, August 22, 1950.

*Other localities*.—One male, Pocahontas, Randolph County, Ark., August 22, 1950. One male collected by Billy C. Rogers, Carthage, Dallas County, Ark., October 8, 1950, differs from the holotype in that the ventral processes of the gonopods are less like the outline of a bird's head and the ocelli are arranged in rows of 1, 7, 6, 5, 4, 3, 1, 1.

*Cleidogona unita*, n. sp.

Figs. 5-9

The ninth legs of the males of this species resemble those of *C. caesioannulata* (Wood) as drawn by Cook and Collins (1896), but the details of the gonopods are nearest those of *C. minima*.

*Male holotype*.—Color brown above and laterally, with the usual areolate buff maculae, the prozonites lighter than the metazonites; cream below; legs cream except the tarsi, which are brown; antennae and vertex of head brown; ocelli dark, forming a triangular patch, arranged in rows of 7, 6, 5, 4, 3, 1 (2).

The ninth legs are as shown by Cook and Collins for *C. caesioannulata* (Wood). The first segments of the tenth and eleventh legs (Figs. 5, 6) have prominent cones on the mesial surface through which the coxal glands open. The sternal

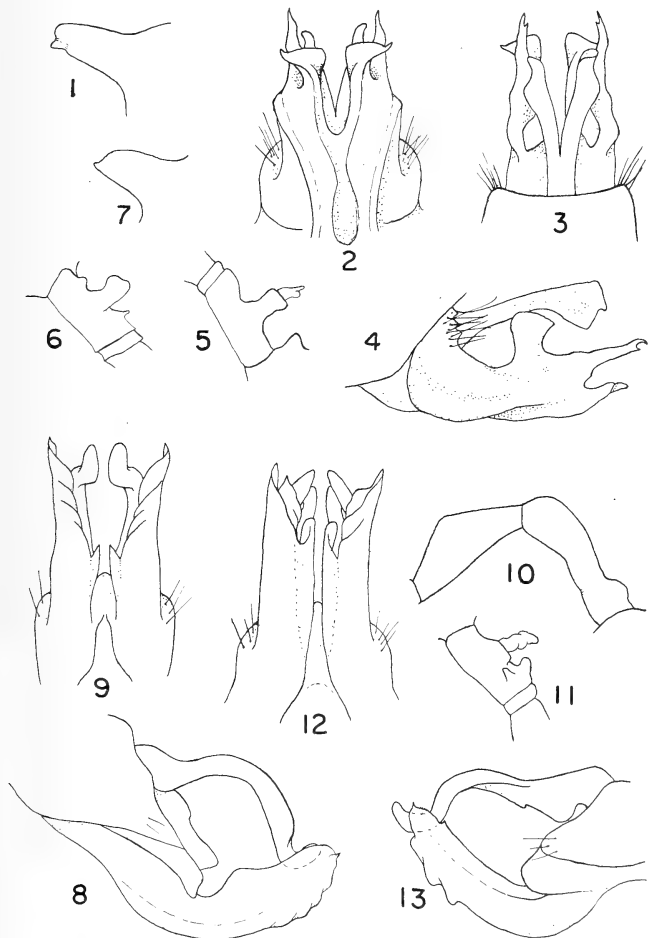

Figs. 1-4.—*Cleidogona aspera*, male paratype: 1, Sternal process at base of twelfth legs, lateral view; 2, ventral view of gonopods; 3, same, dorsal view; 4, lateral view of left gonopod.

Figs. 5-9.—*C. unita*, male holotype: 5, First segment of tenth leg; 6, same, eleventh leg; 7, sternal process at base of twelfth legs; 8, lateral view of left gonopod; 9, ventral view of gonopods.

Figs. 10-13.—*C. minima*, male holotype: 10, First two segments of ninth leg; 11, first two segments of eleventh leg; 12, ventral view of gonopods; 13, lateral view of right gonopod.

process at the base of the twelfth legs is shown in Fig. 7.

The gonopods consist of a wide, dorso-ventrally flattened ventral branch and a cylindrical, sigmoidal dorsal branch (Figs. 8, 9). The ends of the ventral branches are smoother and their medial longitudinal processes are shorter and narrower than in *C. minima*.

*Length* about 14 mm.

*Type locality*.—Illinois: Union County, Giant City State Park. The male holotype and two females were collected March 6, 1945, by Drs. H. H. Ross and M. W. Sanderson. The same collectors took a male and a female March 17, 1942, at Dixon Springs, Ill.

***Cleidogona minima*, n. sp.**

Figs. 10-13

Although the gonopods of this species resemble those of *C. unita* very closely, the two can be distinguished by the differences in size, in the details of the medial processes and ends of the ventral branches of the gonopods, and by the legs of the males.

*Male holotype*.—Color brown above with buff maculae, cream below; segmental setae set in small buff maculae, those at medial setae largest; legs dark distally, cream proximally; antennae and vertex of head dark brown; ocelli dark, forming a triangular patch, arranged in rows of 7, 6, 5, 3, 2, 1.

The first two segments of a ninth leg are shown in Figure 10, and the first segment of an eleventh leg, with two small conical projections on the mesial surface above the opening of the coxal gland, in Fig. 11. The sternal process at the base of the twelfth legs is similar to the one in *C. unita* (Fig. 7).

Each gonopod consists of a cylindrical, sigmoidal dorsal branch and a larger, dorso-ventrally flattened ventral branch. The medial longitudinal process is rolled and larger than the similar process in *C. unita*. Distally the ventral branches are emarginate and sharper than in *C. unita* (Figs. 12, 15).

*Length* 11 to 12 mm.

*Locality*.—Alabama: Tuscaloosa. One specimen collected November 9, 1949, from under pine bark on the campus of the University of Alabama was sent to me by Dr. R. E. Crabill, Jr.

***Cleidogona inflata*, n. sp.**

Figs. 14-19

This species is nearest *C. leona* Chamberlin, with the ventral branches of the gonopods large and inflated and the dorsal branches small and simple.

*Male holotype*.—Color brown above and laterally, with the usual areolate buff maculae; cream below; legs cream except the tarsi, which are brown; antennae and vertex of head brown; ocelli dark, forming a triangular patch, arranged in rows of 1, 7, 6, 5, 4, 3, 2.

On the mesial surface of the first segment of the ninth legs there is a shallow depression and beyond it a sharp lobe (Fig. 14). The first segments of the tenth and eleventh legs, each with an apophysis near the opening of the coxal gland, are shown in Figs. 15 and 16. The sternal process at the base of the twelfth legs is distinctive in the slightly constricted base (Fig. 17).

The large ventral branch of each gonopod terminates in three processes, the lateral one sigmoid and darkly pigmented distally and the other two shorter and lanceolate; the dorsal branches are small and hamate (Fig. 19). *In situ* (Fig. 18) only the ventral branches are visible, their terminal processes outlined against the enlarged body of the branches.

*Length* about 17 mm.

*Type locality*.—Illinois: Putnam County, Starved Rock State Park. The holotype, a female, and a larva were collected July 12, 1944, by Drs. T. H. Frison and M. W. Sanderson. One male, same collectors, August 14, 1944, White Pines State Park, Ogle County, Ill.

***Ozarkogona*, n. gen.**

This genus resembles *Cleidogona* in body shape, absence of keels, smooth surface, shape of first segment, proportion of antennal segments, and in the structure of the gonopods, each of which consists of a hamate ventral branch and a shorter, clavate dorsal branch. The males are distinguished from *Cleidogona* by the absence of a medial sternal process at the base of the twelfth legs and by the ninth legs, which are 4-jointed and with a claw, the first joint enlarged as in *Bactropus*, the second cylindrical and without lobes, the third much shortened, and the fourth narrow but slightly longer than the third. It

differs from *Bactropus* in that the ninth legs are 4-jointed rather than 5-jointed and in the 2-branched gonopods. Gnathochilarium as in *Clei-*

*dogona*. Eyes triangular, composed of about 27 dark ocelli.

*Genotype*.—*Ozarkogona glebosa*, n. sp.

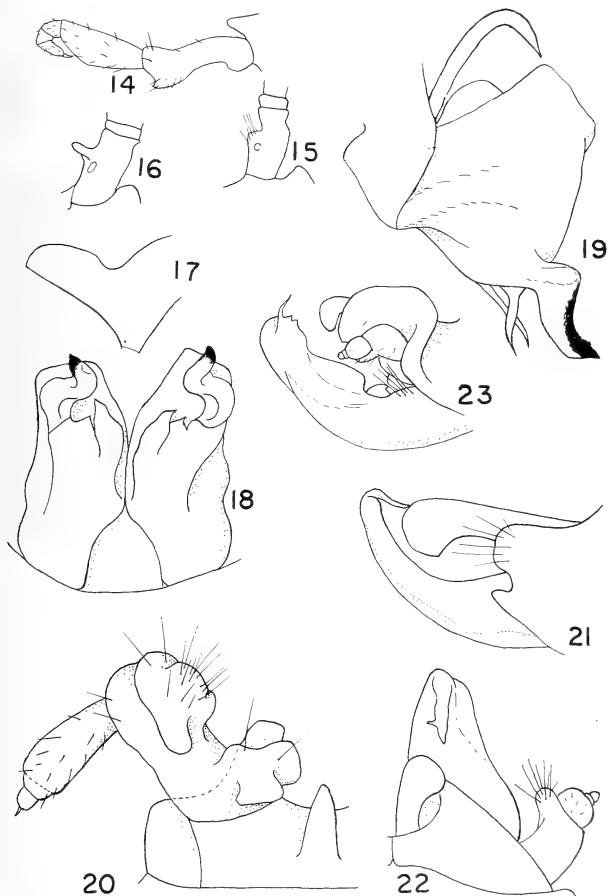

Figs. 14-19.—*Cleidogona inflata*, male holotype: 14, Ninth leg; 15, first segment of tenth leg; 16, same, eleventh leg; 17, sternal process at base of twelfth legs; 18, gonopods *in situ*; 19, lateral view of left gonopod.

Figs. 20-21.—*Ozarkogona glebosa*, male paratype: 20, Cephalic view of ninth leg and sternum; 21, lateral view of right gonopod.

Figs. 22-23.—*Tiganogona moesta*, male paratype: 22, Caudal view of ninth leg and end of dorsal branch of gonopod; 23, lateral view of right gonopod and ninth leg.

**Ozarkogona glebosa**, n. sp.

Figs. 20, 21

*Male holotype*.—Color brown above, cream below; segmental setae set in small buff maculae; larger buff maculae arranged so that there appear to be a lateral buff band and a brown band below it; legs dark distally, cream proximally; antennae and vertex of head brown; ocelli dark, arranged in rows of 1, 7, 6, 5, 4, 3, 2.

The ninth legs (Fig. 20) consist of four segments; the fourth segment is short and ends in a short claw; the third is shorter but thicker; the second is thicker and about three times as long as the combined length of the third and fourth; the first is much enlarged, and on its cephalic surface are two large irregular lobes. The second and third segments appear almost coalesced, and midway of the first segment is an indistinct line that may indicate the coalescence of two segments. The third and fourth segments and the distal parts of the second are brown. A medial sternal process is anterior to the ninth legs, and posterior to them is a wide bifid plate. The gland openings on the first segments of the tenth and eleventh legs are but slightly raised; on the mesial surface, proximal end of the third segments of these legs is a low, cylindrical process.

*In situ* only the medial portion of the appressed ventral branches of the gonopods is visible. In lateral view (Fig. 21) each gonopod is seen to consist of a hamate ventral branch, the end sharp and directed laterad, and a shorter, thick, dorsal branch terminating in a club. *In situ* the dorsal branches pass between the sternal spine and the proximal lobes of the first segment of the ninth legs, while the ventral branches pass under the distal lobes.

*Length* about 16 mm.

*Type locality*.—Arkansas: Fayetteville; 5 males from north end of Mount Kessler, November 10, 1949. Other Arkansas collections have been made at Monte Ne, Benton County; Cane Hill, Washington County; and Clarksville, Johnston County.

**Tiganogona** Chamberlin, *emend.*

*Tiganogona* Chamberlin, Ent. News **39**: 154. 1928.

A recent examination of specimens of *T. brownae* Chamberlin, the genotype, from St. Charles, Mo., shows that the very small ninth legs were overlooked by Dr. Chamberlin, that he

described the tenth legs as the ninth, the eleventh as the tenth, and that his reference to a protuberance on the second joint should be to the third joint. Accordingly, the following emendation must be made: Differing from *Cleidogona* in the ninth legs of the male, which are smaller, 5-jointed, and without a terminal claw; the first segment, the largest, is produced ventrally and may be embraced medially by the dorsal branch of the gonopod; the second segment is much reduced; the third is smaller than the second, and the fourth and fifth segments are minute. Each gonopod consists of two pieces, a dorsally curved ventral branch and a shorter and simpler dorsal branch. Although the ninth legs are minute as in *Ozarkogona*, these two genera are readily separated by the difference in the number of segments and the proportions of the segments of the ninth legs.

*T. brownae* is represented in the Illinois collection by one male from Burton, Ill.

**Tiganogona moesta**, n. sp.

Figs. 22, 23

*Male holotype*.—Color brown above, cream below; dorsal segmental setae set in small buff maculae; medial and lateral segmental setae set in larger, contiguous buff maculae which form a longitudinal band; a brown band is below the buff one; legs cream proximally, brown distally; antennae and vertex of head brown; coelli dark, forming a triangular patch, arranged in rows of 1, 7, 6, 5, 4, 3, 2.

The ninth legs are so small they could be overlooked, but they are made more conspicuous by the brown pigment on the distal three segments. The dorsal branches of the gonopods pass between the first segments and come to rest on the caudal surface; the lobe on the mesial surface of the second segment is almost as large as the globular third segment; segment four is minute; segment five is slightly larger and without a claw (Fig. 23). The first segments of the tenth and eleventh legs are slightly inflated and with the usual gland opening on the mesial surface; on the tenth legs there is a transverse ridge on the cephalic surface of the first segment and a rounded lobe on the proximal end of the mesial surface of the third segment.

The ventral branches of the gonopods are flattened dorso-ventrally distally and curved



gently upward and outward, so that *in situ* part of the dorsal branches and the first segments of the ninth legs are visible between them (Figs 22, 23). The shorter dorsal branches pass between the first segments of the ninth legs and their clavate ends rest on the caudal surface of these segments. Near their base, the ventral branches

pass closely around a medial knoblike protuberance that appears to be a sternal process.

*Length* about 15 mm.

*Type locality*.—Arkansas: Carroll County, Blue Spring; two males, October 29, 1949. The species has been collected at Fayetteville, Washington County, also.

**ICHTHYOLOGY.**—*Additions to the known fish fauna of Mexico: Three species and one subspecies from Sonora.* ROBERT RUSH MILLER and HOWARD ELLIOTT WINN, Museum of Zoology, University of Michigan.

During an ichthyological survey of the Gila River Basin of Arizona, New Mexico, and northern Mexico, in the spring of 1950, the writers made the first fish collections to be recorded from the San Pedro River in Mexico. This stream, once a permanent tributary to Gila River, originates near Cananea in northern Sonora, where peaks of the Cananea Range rise to over 8,000 feet. The surrounding country is open and extremely dry, however, and 15 miles distant, at San Pedro Ranch, the average annual rainfall for the period 1935–1949, inclusive, was only 12 inches (data kindly supplied by Nicholas Sherbakov, San Pedro Ranch). Four collections were made along the main river and in two of its tributaries in the vicinity of San Pedro Ranch, which lies on Río San Pedro about 8 miles south of the international boundary line. The elevation of the ranch is approximately 4,500 feet.

On September 10, 1943, James R. Simon investigated San Bernardino Creek, about 18 miles east of Douglas, Ariz. This stream rises about 2 miles north of the international boundary line and then flows south into Sonora, Mexico, eventually to join Río Yaqui. About 1 mile below the border he took a catfish and a sunfish that constitute new records for Mexico. Neither species is native to the Republic west of the Continental Divide.

The following species are recorded for the first time from Mexico; the specimens are deposited in the University of Michigan Museum of Zoology:

***Catostomus insignis* Baird and Girard**

The Gila coarse-scale sucker was fairly common just above the ranch of Don Rafael Elias,

about 6 miles southwest of San Pedro Ranch, where 13 half-grown and 3 large adults (68–112 and 264–290 mm in standard length) were secured; only one half-grown (114 mm), seined at night, was taken above the large rock dam 2 to 3 miles west of Elias Ranch. Both localities are on a tributary to Río San Pedro, called locally Río San Rafael, which joins the main river about 4 miles upstream from San Pedro Ranch. The specimens were collected by the authors and Frances H. Miller on April 21–22, 1950. One large female extruded ripe eggs under slight pressure, indicating that spawning was imminent or in progress. The water was 73°F., the air 85°F. at 3 p. m.

***Tiaroga cobitis* Girard**

The loach minnow was taken on April 22 in Río San Pedro, at its junction with Río San Rafael, about 4 miles south of San Pedro Ranch. Only 4 adults (37 to 48 mm long), from two rocky riffles, were secured. One riffle was about 25 feet long and formed three rivulets each 1 to 2 feet wide and about 2.5 inches deep. The other riffle, which lay at the head of an undercut pool, was about 8 feet long, up to 4 inches deep, and 2 to 3 feet wide. A long, shallow sandy stretch of approximately 140 feet lay between. The rocks were covered with a short growth of dense green algae and the river was entirely exposed to the bright sun. By using derris root, we obtained this meager sample of a species which undoubtedly was common in the Mexican portion of this river before its flow had become so drastically reduced.

***Ameiurus melas* (Rafinesque)**

Black bullheads were abundant along Río San Rafael, just above the ranch of Don Rafael Elias and in the large reservoir 2 to 3 miles to

the west. From one pool 25 feet long, 3 to 12 feet wide and with a maximum depth of about  $4\frac{1}{2}$  feet, well over 125 catfish, mostly young, were caught and discarded. This pool was cut off by a gravel bar from the main stream, about 5 feet away, and was maintained by a spring seepage at its upper end. In the reservoir this species is much fished for by the natives. The largest specimen we took there weighed 16 ounces. *Ameiurus melas* evidently was introduced at an early date for local testimony indicated that these catfish were here in 1906.

The above material appears to represent the form currently called *A. m. melas* (Rafinesque), the northern black bullhead, for it typically has shorter spines, a heavier body, and perhaps fewer (18 to 21, usually 19 or 20) anal rays than the southwestern subspecies.

The southwestern black bullhead, *Ameiurus melas catulus* (Girard), was seined by J. R. Simon from San Bernardino Creek, 1 mile below the United States border, on September 10, 1943 (3 young to adult, 57-151 mm long). The same subspecies was caught on April 8, 1944, in a pond that lies  $\frac{1}{4}$  mile below the border and a short distance west of San Bernardino Creek (5 adults, 119-209 mm long), by Marvin Frost and John Hendrickson. The anal ray counts of these 8 fish are 20(3), 21(3), and 22(2); the specimens with 20 rays have the elongate dorsal and pectoral spines that are believed to characterize this subspecies.

Two other species, which certainly once inhabited Río San Pedro in Mexico, were not seen by us although we did not work the drainage exhaustively. They may still survive in Mexico or, if not, they may return to this section of the river when (and if) more favorable water conditions prevail again; both species still occur north of the United States-Mexico boundary line in the Arizona portion of Río San Pedro. These two species are: *Pantosteus clarki* (Baird and Girard), the Gila mountain sucker, and *Meda fulgida* Girard, the scaleless spinedace.

#### *Lepomis macrochirus purpurescens* Cope

The southeastern bluegill is represented by 3 adults (102 to 105 mm long) taken by minnow seine in San Bernardino Creek, 1 mile south of the United States border, in water up to 4 feet deep. The broad and comparatively few vertical bars and the 12 anal rays of each specimen confirm the reference to this subspecies, which ranges from Florida north to North Carolina. A southwestern form, *Lepomis macrochirus speciosus* (Baird and Girard) is native to western Texas and tributaries of Río Grande in northeastern Mexico. In this subspecies, the modal number of anal rays is 10 and the dark bars are narrower and more numerous, as in *L. m. macrochirus*. Evidence that *purpurescens* is being (or has been) distributed was obtained by Carl L. Hubbs on June 22, 1938, when he visited the Federal hatchery at San Marcos, Tex. There he saw and obtained (U. M. M. Z. no. 120240) specimens of this subspecies, introduced four years earlier from the Federal hatchery at Lake Park, Ga., which was being reared and hatched at San Marcos for transplantation. In life the soft parts of the posterior fins, particularly the anal, are reddish on the half-grown. This fish, called locally "Georgia bluegill," was being stocked in preference to the native subspecies because it was said to grow faster and take artificial food better. Perhaps the San Marcos hatchery was the source for the sample taken in Sonora, Mexico.

Although we worked San Bernardino Creek from the international line to approximately 2 miles below the border, this species was neither seen nor collected by us on April 24, 1950. The creek was very low, however (almost completely dry in the United States), and the population of bluegills sampled by Simon either may have vanished or may now survive only in the lower portion of San Bernardino Creek where water was reported to be still abundant.

## Officers of the Washington Academy of Sciences

*President*.....NATHAN R. SMITH, Plant Industry Station  
*President-elect*.....WALTER RAMBERG, National Bureau of Standards  
*Secretary*.....F. M. DEFANDORF, National Bureau of Standards  
*Treasurer*.....HOWARD S. RAPPLEYE, U. S. Coast and Geodetic Survey  
*Archivist*.....JOHN A. STEVENSON, Plant Industry Station  
*Custodian and Subscription Manager of Publications*  
 HARALD A. REHDER, U. S. National Museum

### *Vice-presidents Representing the Affiliated Societies:*

Philosophical Society of Washington.....EDWARD U. CONDON  
 Anthropological Society of Washington.....WALDO R. WEDEL  
 Biological Society of Washington.....  
 Chemical Society of Washington.....JOSEPH J. FAHEY  
 Entomological Society of Washington.....FREDERICK W. POOS  
 National Geographic Society.....ALEXANDER WETMORE  
 Geological Society of Washington.....LEASON H. ADAMS  
 Medical Society of the District of Columbia.....  
 Columbia Historical Society.....GILBERT GROSVENOR  
 Botanical Society of Washington.....E. H. WALKER  
 Washington Section, Society of American Foresters.....WILLIAM A. DAYTON  
 Washington Society of Engineers.....CLIFFORD A. BETTS  
 Washington Section, American Institute of Electrical Engineers  
 FRANCIS M. DEFANDORF

Washington Section, American Society of Mechanical Engineers.....RICHARD S. DILL  
 Helminthological Society of Washington.....L. A. SPINDLER  
 Washington Branch, Society of American Bacteriologists.....ANGUS M. GRIFFIN  
 Washington Post, Society of American Military Engineers.....HENRY W. HEMPLE  
 Washington Section, Institute of Radio Engineers.....HERBERT G. DORSEY  
 District of Columbia Section, American Society of Civil Engineers.....

### *Elected Members of the Board of Managers:*

To January 1952.....W. F. FOSHAG, C. L. GAZIN  
 To January 1953.....H. P. BARSS, A. T. MCPHERSON  
 To January 1954.....SARA E. BRANHAM, J. A. STEVENSON

*Board of Managers*.....All the above officers plus the Senior Editor  
*Board of Editors and Associate Editors*.....[See front cover]

*Executive Committee*.....N. R. SMITH (chairman), WALTER RAMBERG, H. S. RAPPLEYE,  
 J. A. STEVENSON, F. M. DEFANDORF

*Committee on Membership*.....L. A. SPINDLER (chairman), M. S. ANDERSON,  
 MERRILL BERNARD, R. E. BLACKWELDER, R. C. DUNCAN, G. T. FAUST, I. B. HANSEN,  
 D. B. JONES, DOROTHY NICKERSON, F. A. SMITH, HEINZ SPECHT, ALFRED WEISSLER

*Committee on Meetings*.....MARGARET PITTMAN (chairman), NORMAN BEKKEDAHL,  
 W. R. CHAPLINE, D. J. DAVIS, F. B. SCHEETZ, H. W. WELLS

### *Committee on Monographs:*

To January 1952.....J. R. SWALLEN (chairman), PAUL H. OEHSE  
 To January 1953.....R. W. IMLAY, P. W. OMAN  
 To January 1954.....S. F. BLAKE, F. C. KRACEK

*Committee on Awards for Scientific Achievement* (GEORGE P. WALTON, general chairman):

For the Biological Sciences.....G. H. COONS (chairman), J. E. FABER, JR.,  
 MYRNA F. JONES, F. W. POOS, J. R. SWALLEN

For the Engineering Sciences.....R. S. DILL (chairman), ARSHAM AMIRIKIAN,  
 J. W. MCBURNEY, FRANK NEUMAN, A. H. SCOTT

For the Physical Sciences.....G. P. WALTON (chairman), F. S. BRACKETT,  
 G. E. HOLM, C. J. HUMPHREYS, J. H. McMILLEN

For Teaching of Science.....B. D. VAN EVERA (chairman), R. P. BARNES,  
 F. E. FOX, T. KOPPANYI, M. H. MARTIN, A. T. MCPHERSON

*Committee on Grants-in-aid for Research*.....L. E. YOCUM (chairman),  
 M. X. SULLIVAN, H. L. WHITTEMORE

### *Committee on Policy and Planning:*

To January 1952.....J. I. HOFFMAN (chairman), M. A. MASON  
 To January 1953.....W. A. DAYTON, N. R. SMITH  
 To January 1954.....H. B. COLLINS, JR., W. W. RUBEY

### *Committee on Encouragement of Science Talent:*

To January 1952.....M. A. MASON (chairman), A. T. MCPHERSON  
 To January 1953.....A. H. CLARK, F. L. MOHLER  
 To January 1954.....J. M. CALDWELL, W. L. SCHMITT

*Representative on Council of A. A. A. S.*.....F. M. SETZLER

*Committee of Auditors*.....J. H. MARTIN (chairman), N. F. BRAATEN, W. J. YOUDEN

*Committee of Tellers*.....W. G. BROMBACHER (chairman), A. R. MERZ, LOUISE M. RUSSELL

## CONTENTS

	Page
ARCHEOLOGY.—A survey of new archeological sites in central Pataz, Peru. PHILIP D. CURTIN.....	49
PALEONTOLOGY.—Check list of salinity tolerance of post-Paleozoic fossil Ostracoda. I. G. SOHN.....	64
BOTANY.—Peter Wilhelm Lund's pequi tree at Lagoa Santa and pil- grimages to his cemetery. ANNA E. JENKINS, A. A. BITANCOURT, K. SILBERSCHMIDT, and W. ANDREW ARCHER.....	66
ZOOLOGY.—Notes on the undescribed males of two species of Copepoda. S. KRISHNASWAMY.....	75
ZOOLOGY.—New cleidogonid millipeds (Chordeumoidea). NELL B. CAUSEY	78
ICHTHYOLOGY.—Additions to the known fish fauna of Mexico: Three species and one subspecies from Sonora. ROBERT RUSH MILLER and HOWARD ELLIOTT WINN.....	83

Sub. 12  
D2Wd3

Vol. 41

MARCH 1951

No. 3

# JOURNAL

OF THE

# WASHINGTON ACADEMY OF SCIENCES

### BOARD OF EDITORS

CHARLES DRECHSLER  
PLANT INDUSTRY STATION  
BELTSVILLE, MD.

WILLIAM F. FOSHAG  
U. S. NATIONAL MUSEUM

J. P. E. MORRISON  
U. S. NATIONAL MUSEUM

### ASSOCIATE EDITORS

J. C. EWERS  
ANTHROPOLOGY

C. W. SABROSKY  
ENTOMOLOGY

F. A. CHACE, JR.  
BIOLOGY

J. I. HOFFMAN  
CHEMISTRY

T. P. THAYER  
GEOLOGY

MIRIAM L. BOMHARD  
BOTANY

R. K. COOK  
PHYSICS AND MATHEMATICS

PUBLISHED MONTHLY  
BY THE  
WASHINGTON ACADEMY OF SCIENCES  
MOUNT ROYAL & GULLFORD AVES.  
BALTIMORE, MARYLAND

Entered as second class matter under the Act of August 24, 1912, at Baltimore, Md.  
Acceptance for mailing at a special rate of postage provided for in the Act of February 28, 1925  
Authorized February 17, 1949



## Journal of the Washington Academy of Sciences

This JOURNAL, the official organ of the Washington Academy of Sciences, publishes: (1) Short original papers, written or communicated by members of the Academy; (2) proceedings and programs of meetings of the Academy and affiliated societies; (3) notes of events connected with the scientific life of Washington. The JOURNAL is issued monthly. Volumes correspond to calendar years.

*Manuscripts* may be sent to any member of the Board of Editors. It is urgently requested that contributors consult the latest numbers of the JOURNAL and conform their manuscripts to the usage found there as regards arrangement of title, subheads, synonymies, footnotes, tables, bibliography, legends for illustrations, and other matter. Manuscripts should be typewritten, double-spaced, on good paper. Footnotes should be numbered serially in pencil and submitted on a separate sheet. The editors do not assume responsibility for the ideas expressed by the author, nor can they undertake to correct other than obvious minor errors.

*Illustrations* in excess of the equivalent (in cost) of one full-page halftone are to be paid for by the author.

*Proof.*—In order to facilitate prompt publication one proof will generally be sent to authors in or near Washington. It is urged that manuscript be submitted in final form; the editors will exercise due care in seeing that copy is followed.

*Unusual cost* of foreign, mathematical, and tabular material, as well as alterations made in the proof by the author, may be charged to the author.

*Author's Reprints.*—Reprints will be furnished in accordance with the following schedule of prices (approximate):

Copies	4 pp.	8 pp.	12 pp.	16 pp.	20 pp.	Covers
100	\$3.25	\$6.50	\$ 9.75	\$13.00	\$16.25	\$3.00
200	6.50	13.00	19.50	26.00	32.50	6.00
300	9.75	19.50	29.25	39.00	48.75	9.00
400	13.00	26.00	39.00	52.00	65.00	12.00

*Subscriptions* or requests for the purchase of back numbers or volumes of the JOURNAL or the PROCEEDINGS should be sent to HARALD A. REHDER, Custodian and Subscription Manager of Publications, U. S. National Museum, Washington 25, D. C.

*Subscription Rates* for the JOURNAL.—Per year..... \$7.50

Price of back numbers and volumes:	Per Vol.	Per Number
Vol. 1 to vol. 10, incl.—not available.*	—	—
Vol. 11 to vol. 15, incl. (21 numbers per vol.)	\$10.00	\$0.70
Vol. 16 to vol. 22, incl. (21 numbers per vol.)	8.00	0.60
Vol. 23 to current vol. (12 numbers per vol.)	7.50	0.90

\* Limited number of complete sets of the JOURNAL (vol. 1 to vol. 40, incl.) available for sale to libraries at \$341.00

MONOGRAPH No. 1, "The Parasitic Cuckoos of Africa," by Herbert Friedmann. \$4.50

PROCEEDINGS, vols. 1-13 (1899-1911) complete..... \$25.00

Single volumes, unbound..... 2.00

Single numbers..... .25

*Missing Numbers* will be replaced without charge provided that claim is made to the Treasurer within 30 days after date of following issue.

*Remittances* should be made payable to "Washington Academy of Sciences" and addressed to the Treasurer, H. S. RAPPLEYE, 6712 Fourth Street, N.W., Washington 12, D.C.

*Exchanges.*—The Academy does not exchange its publications for those of other societies.

# JOURNAL OF THE WASHINGTON ACADEMY OF SCIENCES

VOLUME 41

March 1951

No. 3

ARCHEOLOGY.—*Additional data on the Denbigh Flint Complex in northern Alaska.* RALPH S. SOLECKI, Bureau of American Ethnology, and ROBERT J. HACKMAN, U. S. Geological Survey.

Two especially interesting discoveries of artifactual data in the region north of the Arctic Circle in Alaska were made during the summer of 1950. Both are the recovery of specimens typologically similar to the Denbigh Flint Complex (Giddings, 1949 and MS.), an early flint horizon on the north Bering Sea (Fig. 1). One discovery was made on a lake at the foot of the Brooks Range<sup>1</sup> by the junior author. His finds were supplemented by those of George Gryc, who, like the former, is with the U. S. Geological Survey.

This report is a preliminary one, since the significance of the data in its entirety can not be extracted from the evidence at this time. However, this is the second area in the north to produce the unique, finely worked flints and burins in association with a fluted point, all of which may be compared with the "mesolithic" flints J. L. Giddings, Jr. (op. cit.) has recovered at Cape Denbigh. The site discussed in this paper is situated on Lake Natvakuak,  $7\frac{1}{2}$  miles north of the mouth of Anaktuvuk Pass, which is one of the best migration pass routes through the Brooks Range Province to the northern slope of Alaska (Solecki, 1950, p. 147). The location of this apparently early occupation close to Anaktuvuk Pass leads us to believe that this mountain breach was probably then in use, just as it is still used by the "Nunamiut"<sup>2</sup> Eskimos today. The latter people are the survivors of the once large group of inland Alaskan Eskimos living north of the Brooks

Range. The Nunamiut Eskimos at Anaktuvuk Pass know the lake very well, as their ancestors had reportedly known it before them. Once teeming with edible fish, the lake is now of lessened importance because the numbers of fish have decreased. It is suspected that an ecological change has caused this.

The lake as well as the occupations was definitely postglacial, since they lay in a morainal area.<sup>3</sup> The artifacts were recovered close to the surface, barely at the base of the tundra roots. The small accumulation of soil covering on the site is accounted for by a set of interrelated factors, namely, a very low annual precipitation (5-7 inches), the frigidity of the climate most of the year, a very little erosion, and little deposition of humus because of scant vegetal life.

The field party that the junior author accompanied made camp upon the lake shore between August 4 and 14, 1950. During about three days of this time he found opportunity to check the area for archeological data. Actually two occupational areas were discovered, called here for convenience, sites 1 and 2. These were almost at opposite ends of the nearly mile long oblong-shaped Lake Natvakuak. One site (no. 1) was situated at the northern end, and the other (no. 2) was near the southern end. A narrow tortuous stream outlet drains the lake at the northeast corner to the Sik-Sik-Puk River, thence to the Chandler and Colville Rivers

<sup>1</sup> The other site was located by William Irving, a student at the University of Alaska, and is near Anaktuvuk River in the pass.

<sup>2</sup> The name that these people give themselves according to Robert Rausch, U. S. Public Health Service.

<sup>3</sup> Recent Carbon-14 dating of the glacial recession as of about 12,000 years ago for the Midwest of the United States (Anonymous, 1950, p. 243) presents us with a clue to the greatest possible age of these northern finds. In effect, the archeological guess dates appear to be telescoped or shortened by this atomic age method.

north to the Arctic Ocean. In search for clues to possible old strand lines, it was revealed that there are evidences of former beaches 4 to 6 feet higher than the normal lake level. These beach lines are no guarantee of antiquity, however, since the outlet may be seasonally choked with ice and debris during the spring break-up of the ice which would cause the lake level to rise. Indeed, the lake seems to be contained within the same limits as at the time of the oldest occupation there.

Site 1 lay strung along the top of a small morainal ridge which dammed the lake. Seventeen features were found there, including tent rings of stone and cut caribou antlers, fire hearths, and similar occupational evidence, mostly of recent date. Artifacts of chipped stone were rare, only 40 chert flakes and 3 classifiable stone artifacts having been recovered from this site. These specimens

were found in a longitudinal area of about 180 yards long, or one-third of the extent of the site. One of the artifacts, a broad black chert flake, was serrated around the perimeter (Fig. 2, *l*).

The remainder of the stone artifacts were found at site 2. This was a narrow morainal peninsula 400 yards long that jutted into the lake approximately three-fourths of a mile to the south and west of site 1. Stone artifacts were found in two concentrations upon the peninsula. Stone flakes occurred generally broadcast over the area. No stone tent circles were observed on the peninsula proper, although three stone circles were found on the mainland. There were also indications of recent Eskimo occupations on the peninsula and mainland, none of which should be confused with the evidence of earlier habitat.

It was beneath the surface-covering of

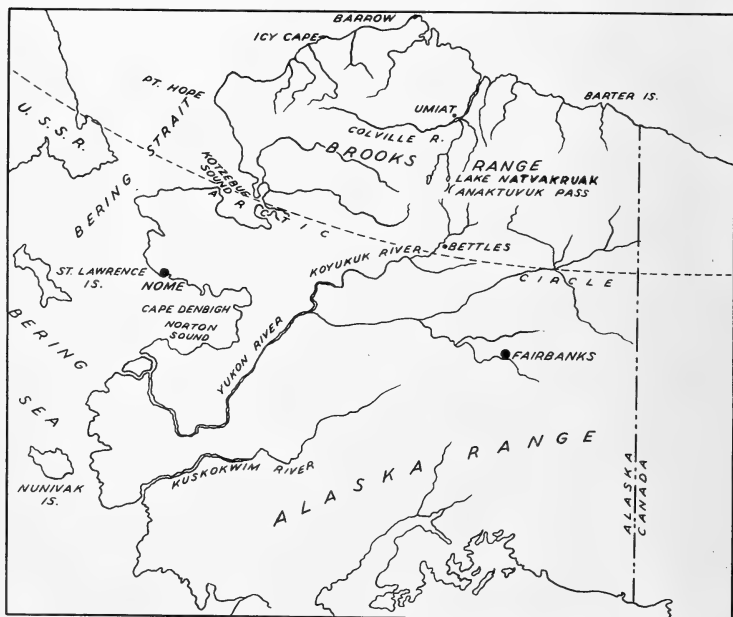

FIG. 1.—Map of northern Alaska showing the locations of Cape Denbigh and Lake Natvakrauk.



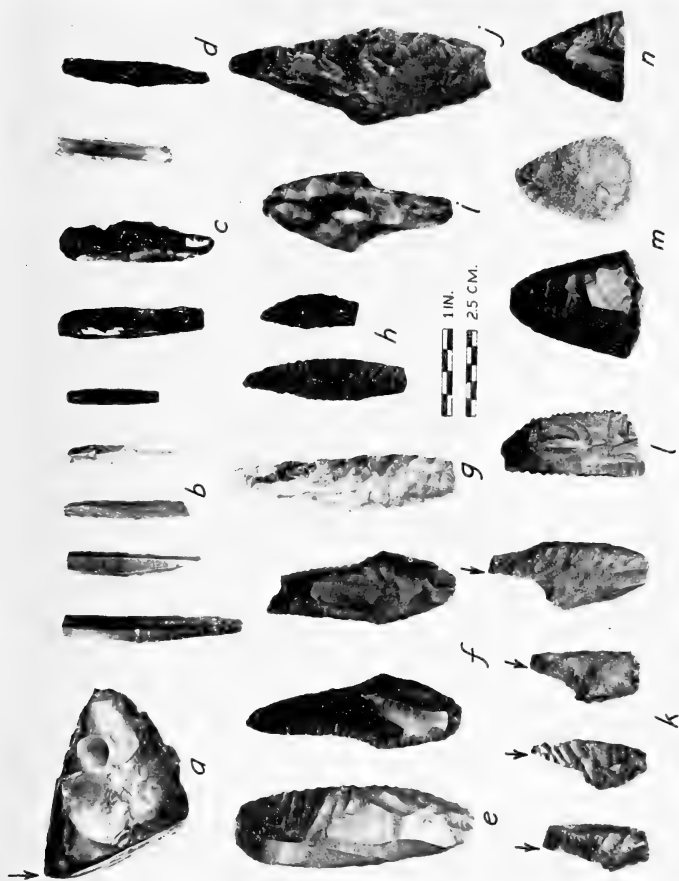

FIG. 2. Representative archaeological specimens found at Lake Natvakruak, which are typologically similar to the Denbigh Flint Complex.

tundra, at a depth of about 5 to 10 inches, that the majority of the specimens resembling the Denbigh Flint Complex artifacts were found. Even though most of the data were recovered closer to the 10-inch depth, this shallowness of deposit contrasts with the approximately 7-foot depth at Cape Denbigh where Giddings (*op. cit.*) recovered

his flints. Assuming that there had been no time lag in occupation, we can only believe that the mechanics of soil formation may have been slower in progression north of the Brooks Range.

Of the 97 artifacts submitted to the senior author for study, 80 are identifiable with Giddings' early flint horizons. All these arti-

facts are of locally derived chert, with the exception of 11 lamellar flakes of obsidian. Among the finds are the following: one semi-polyhedral core from the forward end of which were struck lamellar flakes (Fig. 2, *a*), lamellar flakes represented by (Fig. 2, *b*) and (Fig. 2, *c*), the latter being of obsidian, thin curved spawl detached from a finished flint edge (Fig. 2, *d*), a large convex blade of ovate shape (Fig. 2, *e*), convex end blades (Fig. 2, *f*), finely worked side and end blades (Fig. 2, *g*, *h*), a convex stemmed blade which shows attritional wear (Fig. 2, *i*), a long-stemmed blade with a broken point showing attritional wear on the blade (Fig. 2, *j*). Fig. 2, *k*, illustrates a group of 4 out of 13 artifacts classifiable as burins—a diagnostic trait of the Denbigh Flint Complex. Only one of the burins recovered shows wear from purposeful use as a burin. These artifacts were originally side and end scrapers, showing attritional wear on one or more edged sides. Their preparation for use as burins was therefore a new functional adaptation. Flakes were expertly struck off parallel to the long axis at the distal end, forming a series of steplike niches in one corner. Among the remainder of the illustrated artifacts are a serrated flake (Fig. 2, *l*) which was found at site 1, two end scrapers (Fig. 2, *m*), and the point end of a projectile point, fluted on both surfaces (Fig. 2, *n*). It is to be recalled that Giddings (MS.) has also found a fluted projectile point in his recent excavations at Cape Denbigh associated with

artifacts of this complex. At present the associations of Folsom with the Denbigh Flint Complex are not clear. Although Folsom points do occur in Alaska, no actual sites of Folsom occupation like those on the western plains of the United States have yet been found in the north.

Of considerable importance is the fact that we have another stepping stone in the chain of evidence of an ancient trail leading from the Bering Straits area into the heart of North America. This trail is now more literally than figuratively true, since Anaktuvuk Pass is one of the few good through routes connecting the Colville River drainage on the north with the drainages flowing on the south side of the Brooks Range. This evidence, consolidated with other as yet unpublished archeological data on the north slope, bids fair to making this area one of the better archeologically known parts in Alaska.

#### LITERATURE CITED

- ANONYMOUS. *New age for American Man*. Science News Letter **58** (16): 243. Oct. 14, 1950.
- GIDDINGS, J. L., JR. *Early flint horizons on the north Bering Sea coast*. Journ. Washington Acad. Sci. **39** (3): 85-90. 1949.
- . *Recent finds at Cape Denbigh*. Paper presented at annual meeting of American Anthropological Association, New York, 1949. MS.
- SOLECKI, RALPH S. *New data on the Inland Eskimo of northern Alaska*. Journ. Washington Acad. Sci. **40** (5): 137-157. 1950.

ENTOMOLOGY.—*Dinoponera gigantea* (Perty), a vicious stinging ant. H. A. ALLARD, Washington, D. C.

From late October 1949 until the second week in March 1950 I was in Tingo Maria and other points in eastern Peru collecting herbarium specimens, insects, and other natural-history material for the Smithsonian Institution at Washington, D. C.

Tingo Maria is a small jungle-town in the rain-forest region on the east slope of the Andes. It is situated in a most beautiful and picturesque little mountain-enclosed tropical valley through which the Huallaga River flows, forming one of the important tributaries of the great Amazon.

During my botanical explorations of the area I spent much time in the dense tropical jungles and deep ravines along the high ridges just east and west of Tingo Maria. Hardly had I arrived there when I made the acquaintance of the huge, black stinging ant *Dinoponera gigantea*. I found it wandering about everywhere on the trails and throughout the jungle generally. It is a handsome, shining black insect an inch or more in length and fears no one. My first actual contact with this vicious ant was a most painful one. Early one afternoon I attempted

to pick one up as a specimen to transfer it to my killing bottle by using several folds of my handkerchief. In spite of this I received a severe thrust of its powerful sting into the end of my index finger. The pain was soon excruciating and lasted until well into the night. So severe was the pain that at times my hand trembled. The next day there were redness and swelling, but no other local symptoms were present. The redness and swelling soon subsided, but a small black spot penetrating deep into the tissues remained at the site of the puncture for a week or more.

Some weeks later I had a far more painful experience with this ant. I had been exploring the jungle away from the trail, trudging through the humus and herbage of the primitive forest, wearing a pair of low canvas tennis shoes of Peruvian manufacture. Somehow I had stepped into or disturbed a colony of these huge ants as I sank into a bed of humus and fallen leafage beside an old decaying log. Two of the ants stung me at the ankle, and in a short time I was in the throes of an agony of burning pain—a pain such as I have never experienced before, nor ever care to repeat as an experience. This was early in the afternoon and at suppertime, 6 p.m., the pain was so intense that I could not keep my foot quiet for any length of time but was forced even to walk about. It had become a most excruciating, throbbing, burning pain and lasted far into the night until sleep intervened. Next morning the pain was nearly gone, but redness, swelling, and tenderness of the ankle persisted for some days. As in the former instance there was no evidence of any local effect on the punctured tissues.

Weeks later while attempting to gather blossoms of a liana on a tree trunk about 6 feet from the ground I placed my right hand on another of these ants and received a sting in the end of my middle finger. As usual the pain was intense and persisted for many hours with redness and swelling, but no local effects developed as in the two previous cases.

Some months later my son's little boy, not much over three years old, accompanied by his father, was paddling in the little brook near the house and playing in the sand on

the bank. Suddenly there was a piercing shriek, for he had spied one of these big ants and with a child's curiosity had picked it up, with a resulting severe sting. His suffering was most intense, for he had been stung in the ball of the thumb. There was nothing one could do to quiet him, and he screamed until far into the evening when sleep finally dulled his sensibilities. Next morning there was some redness but no local effects were noticeable. He had, however, learned a most painful lesson, and these ants and other insects were regarded with great suspicion thereafter.

The next victim was my son's cocker spaniel, Rusty. This friendly little animal often accompanied me into the deep jungles. On the day in question we had followed nearly a mile up a steep trail, the little dog trotting along contentedly just ahead of me. Suddenly it gave a jump and assumed a most crestfallen air, rolling around and biting at a hind foot. It had stepped upon one of these stinging ants and at once showed signs of great pain. It no longer had any interest in the trip and suddenly bolted down the trail for home on three legs. I felt responsible for its welfare, so turned back to the house. I found the dog lying on the grass in the backyard and in great pain. It held its hind foot in the air and kicked and bit at it from time to time. The animal was whining and trembling like a leaf and could not remain still. This behavior continued until well into the evening, hours after it had received the sting. Next day some swelling was evident, but no further effects were noticeable.

Neal A. Weber has published accounts of his experiences with the sting of another large ant, *Paraponera clavata* (Fabricius), in Venezuela, first in 1937 in the paper "The Sting of an Ant" (Amer. Journ. Trop. Med. 17 (5). 1937) and later in "The Sting of the Ant, *Paraponera clavata*" (Science, Feb. 10, 1939, pp. 127-128). In the first instance he was stung on the knee, and blisters formed at the site. These local effects persisted for at least a week and the area was red 19-20 days after the sting was received. In my own case there were no local disturbances such as blisters and no systemic effects, as in Weber's experiences. It is probable that different individuals may show marked differ-

ences in their physiological reactions to these stings.

Throughout the tropical rain forests the natives are very familiar with both ants, and are very fearful of their vicious stings. In his book *Ant Hill Odyssey* (1948, p. 91), Dr. William M. Mann says that to the natives in Brazil *Dinoponera grandis* (a synonym of *gigantea*) is known as "tocandero," and they claim that its sting causes a fever.

I was told by natives at Tingo Maria that the sting of *Dinoponera gigantea* has put people in bed and that it can prove fatal. It is much dreaded in this area, as well as elsewhere in those regions where its range extends. According to Weber, in the papers cited, the sting of *Paraponera clavata* is considered to be fatal, and it is designated by the natives as "viente cuatro hormiga," or 24-hour ant, because one is thought to die in 24 hours after being stung. As is usual in such instances, the native mind is prone to gross exaggerations, although it is possible that allergic individuals may sometimes suffer very severe reactions, both local and systemic, for this actually occurs in the case of simple wasp and bee stings in our own country.

My son has two small, white-faced native monkeys in a large cage outdoors at Tingo Maria, and these are mortally afraid of the large stinging ants. Often I have seen these ants wandering about on the ground in the cage. The little monkeys take to their perch at once and eye the ants below them with every evidence of profound fear, and well they may.

The workers and larger queens are equipped with a sting. Both *Dinoponera gigantea* and *Paraponera clavata* are ground-inhabiting species, and I have never seen them very far from the ground on tree trunks in the jungle. They are usually seen wandering singly over the trails and jungle floor, and can be met with almost anywhere in such situations. These ants appear to be predacious hunting species, for on several occasions I have seen individuals of *Dinoponera gigan-*

*tea* roaming about with grasshoppers, spiders, and other arthropods in their mandibles which, presumably, they had captured.

It would be a nice problem for a good organic chemist to study the nature of the venom injected by such ants, as well as that of various bees and wasps. It is known that the venom of different poisonous snakes is far from being of identical composition, and such may be the case with the stinging ants and bees. It may well be something more than a mere quantitative difference concerned with simple formic acid. Perhaps there are qualitative differences as in the case of the complex venoms of different species of snakes.

In my own experience the effects of the sting of *Dinoponera gigantea* have differed somewhat from the stings of bees and wasps in our own country and in the Tropics, and I have been stung by many species of our larger wasps, hornets, and bees and have been bitten by some spiders. Usually there is a more localized puffing up or swelling at the immediate site of the puncture or bite, and this may assume a paler or whiter appearance than the normal skin shows. These ants have never produced such effects in my own experience, but only a generalized redness and swelling, with an intense pain of quite different character. There is one difference in the nature of the puncture of this ant. Its stinging organ is exceedingly long and consequently it appears to be thrust more deeply into the tissues. From the exceptional intensity of the pain one must conclude that a relatively large dosage of venom is present, though the constituents are unknown. Whatever the character of the venom may be, *Dinoponera gigantea*<sup>1</sup> is an ant that brooks no familiarity and is one to avoid, owing to the excruciating pain of its powerful sting.

<sup>1</sup> Students of the species have recognized varietal forms, but I am using the name in a broad sense. I am indebted to M.R. Smith, U.S. Bureau of Entomology and Plant Quarantine, for ant identifications and for suggesting references to Dr. Weber's observations.

ZOOLOGY.—A revision of the nomenclature of the Gorgoniidae (Coelenterata: Octocorallia), with an illustrated key to the genera. FREDERICK M. BAYER, U. S. National Museum.

A superficial inquiry into the nomenclature of the Gorgoniidae was sufficient to reveal a state of confusion in the systematics of that family. Thorough search was therefore begun in order to discover the origin of this confusion and means of its clarification. Apparently, the principal source of error has been the acceptance of incorrect genotypes, without considering the earliest valid designations.

The latest revision of the Gorgoniidae was undertaken by Miss Eva Bielschowsky, a student of the noted zoophytologist Willy Kükenthal. Her preliminary study, prepared as a doctoral dissertation, was published in 1918; considerably expanded, it appeared again in 1929. In these works, Miss Bielschowsky unfortunately overlooked the early type designations of Milne Edwards and Haime and A. E. Verrill. These oversights were in some cases of little consequence, but the correction of two of them will greatly affect modern concepts of gorgoniid nomenclature.

The classification proposed in Miss Bielschowsky's thesis has been accepted without question in late years, and the incorrect name combinations used therein have become familiar. However, I feel that asking for a suspension of the International Rules of Zoological Nomenclature to preserve these combinations resulting from superficial research is not warranted by the limited zoological interest and importance of the gorgoniids.

The two changes necessary are the suppression of *Rhipidigorgia* Valenciennes, 1855, as a synonym of *Gorgonia* Linné, 1758, the genotype of both being *Gorgonia flabellum* Linné; and of *Xiphigorgia* Milne Edwards and Haime, 1857, as a synonym of *Pterogorgia* Ehrenberg, 1834, the genotype of both being *Gorgonia anceps* Pallas.

The disappearance of the name *Rhipidigorgia* could have been prevented had Miss Bielschowsky taken the proper precautions in her revision. Furthermore, the name *Xiphigorgia* could have been synonymized before it had an opportunity to become well established in the modern literature.

To summarize the history of this confusion: Linné's genus *Gorgonia*, 1758, was a heterogeneous collection of nine species: *G. spiralis*, *ventalina*, *flabellum*, *antipathes*, *ceratophyta*, *pinnata*, *aenea*, *placomus*, and *abies*. Of these, three (*spiralis*, *aenea*, and *abies*) are antipatharians and do not concern us here; one (*antipathes*) is a plexaurid and one (*placomus*) a muriceid, and were removed from *Gorgonia* by Lamouroux and Ehrenberg respectively. In 1834, Ehrenberg created *Pterogorgia* for eight species including *Gorgonia acerosa* Pallas, *G. fasciolaris* Esper (var. of *citrina*) and *G. anceps* Pallas. In 1850, Milne Edwards and Haime designated *G. anceps* as the type of *Pterogorgia*. In 1855, Valenciennes proposed the genus *Rhipidigorgia* for those species with anastomosing branches, but failed to designate a type species. Then, in 1857, Milne Edwards and Haime established *Xiphigorgia* for one species with trialate and another with whip-like branches, *Gorgonia anceps* Pallas and *G. setacea* Pallas, the first of which they had already selected as the type of *Pterogorgia*. At the same time these authors erected *Leptogorgia* for several species of slender-branched gorgoniids, but, as in *Xiphigorgia*, failed to indicate a type species. Prof. A. E. Verrill in 1868 established without a type species the genus *Litigorgia* for several species of gorgoniids including two with anastomosing branches and five with free branches. In a later paper in the same year, he designated *G. flabellum* Linné as the type of *Gorgonia*, *G. acerosa* Pallas as the type of *Pterogorgia* (overlooking Milne Edwards and Haime's selection of *G. anceps* as the type of that genus), *L. florae* Verrill as the type of *Litigorgia*, and *Gorgonia viminialis* Pallas *sensu* Milne Edwards and Haime as the type of *Leptogorgia*. A status quo obtained until 1918, when Miss Bielschowsky stated in her revision that *G. flabellum* was the type of *Rhipidigorgia*, thereby making it an absolute synonym of *Gorgonia*. Had she realized that Verrill already had used that species as the type of *Gorgonia*, she might have preserved *Rhipidigorgia* by a judicious choice of genotype species.

## GORGONIIDAE

*Diagnosis.*—Holaxonians with branching usually in one plane, lateral or pinnate, alternate or opposite; anastomosis of the twigs present or absent. Zooids usually infrequent or absent at the base of colony, and ordinarily occurring in

two lateral rows along stems and branches; low verrucae present or absent. Anthocodial armature usually a weak crown of small, more or less flattened rods or spindles which are either warted or practically smooth. Spicules of the coenenchyma are spindles with regular transverse belts of warts, reaching 0.3 mm in length; spindles

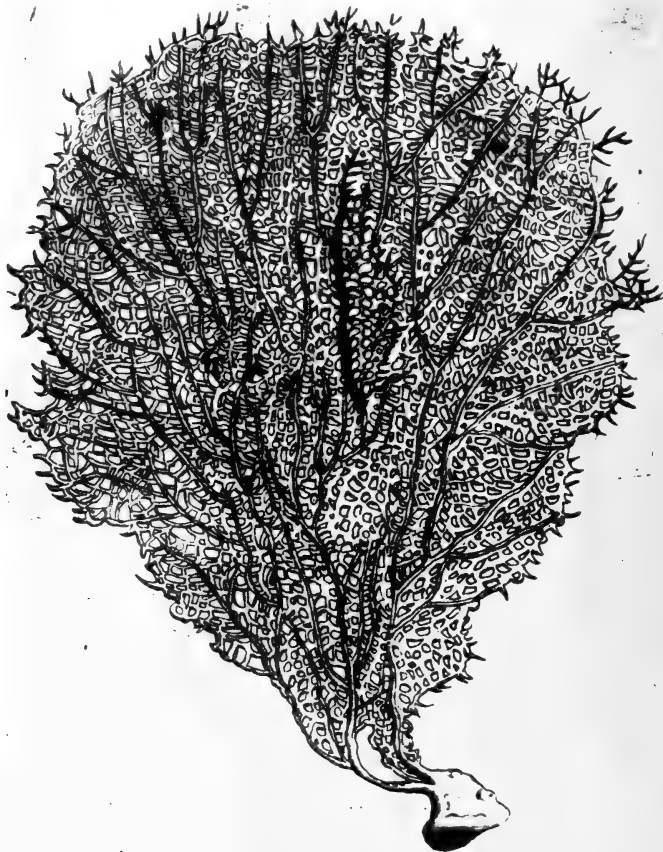

FIG. 1.—*Gorgonia flabellum* Linné. Copied from B. Cerutus, *Musæum Franc. Calceolari* Inn. *Veronensis*: 16, 1622. This is probably the best post-Renaissance illustration of this well-known animal.

with the warts fused to form disks, and peculiar bent spindles (scaphoids) occur in certain genera. Axis horny, with little or no loculation of the cortex.

*Remarks.*—The genus *Swiftia* Duchassaing and Michelotti, 1860 (monotype *Gorgonia exserta* Ellis and Solander) [= *Stenogorgia* Verrill, 1888 (*S. casta* Verrill) = *Callistephanus* Wright and Studer (*C. koreni* Wright and Studer)] should be transferred to the family Muriceidae.

#### Genus *Gorgonia* Linné

*Gorgonia* (part) Linné, 1758, *Syst. Nat.*, ed. 10, 1: 800. [Type *G. flabellum* L., subs. des. Verrill, 1868, *Trans. Connecticut Acad.* 1: 386.]

not *Gorgonia* Bielschowsky, 1918, *Revis. Gorg.*: 32; Kükenthal, 1919, *Wiss. Ergeb. deutschen Tiefsee-Exped.* 13 (2): 852; Kükenthal, 1924, *Das Tierreich* 47: 338; Deichmann, 1936, *Mem. Mus. Comp. Zool.* 53: 174.

*Rhipidigorgia* (part) Valenciennes, 1855, *C. R. Acad. Sci. Paris* 41: 13. [Type, *G. flabellum* L., subs. des. Bielschowsky, 1918, *Revis. Gorg.*: 49.]

*Rhipidogorgia* [sic] Duchassaing and Michelotti, 1860, *Mém. corall. Antill.*: 33; Kükenthal, 1916, *Zool. Jahrb., Suppl.* 11: 485; Bielschowsky, 1918, *Revis. Gorg.*: 49; Kükenthal, 1919, *Wiss. Ergeb. deutschen Tiefsee-Exped.* 13 (2): 853; Kükenthal, 1924, *Das Tierreich* 47: 350; Deichmann, 1936, *Mem. Mus. Comp. Zool.* 53: 192.

*Diagnosis.*—Colonies with branching in one plane developed as one or more flat fans; twigs closely anastomosing to form a regular network. Zooids in two lateral rows on the twigs, either with very low verrucae or retracting flush with the coenenchyma surface; anthocodial armature of weakly sculptured rods. Coenenchyma spicules as girdled spindles and stout scaphoids.

*Genotype.*—*Gorgonia flabellum* Linné, 1758 (subsequent designation: A. E. Verrill, 1868, *Trans. Connecticut Acad.* 1: 386).

#### *Gorgonia flabellum* Linné

Fig. 1

*Frutex marinus elegantissimus* Clusius, 1605, *Exoticorum*: 120 fig.

*Planta marina retiformis* Olearius, 1674, *Gottorf. Kunst-Kamm.*: 69, pl. 35, fig. 2.

*Planta retiformis maxima* + *Frutex marinus major* Lochner, 1716, *Rar. mus. Besl.*: 78, 79, pl. 24.

*Flabellum Veneris* Ellis, 1755, *Essay nat. hist. corallines*: 61, pl. 26, fig. k.

*Gorgonia flabellum* Linné, 1758, *Syst. Nat.*, ed. 10, 1: 801; Esper, 1791, *Pflanzenziere* 2: 23, pls. 2-3a; Verrill, 1869, *Amer. Journ. Sci.* 43: 424; Hargitt and Rogers, 1901, *Bull. U. S. Fish. Comm.* 20 (2): 287, pl. 3, fig. 3.

*Rhipidigorgia flabellum* Valenciennes, 1855, *C. R. Acad. Sci. Paris* 41: 13.

*Rhipidogorgia* [sic] *flabellum* Duchassaing and Michelotti, 1860, *Mém. corall. Antill.*: 33; Kükenthal, 1916, *Zool. Jahrb., Suppl.* 11: 485; Kükenthal, 1924, *Das Tierreich* 47: 350, fig. 180; Bielschowsky, 1929, *Zool. Jahrb., Suppl.* 16: 194.

The name by which this species was known for many years is hereby restored. *Gorgonia flabellum* was among the first objects of curiosity brought back from the New World, and published records of it date back well over 300 years. The accompanying illustration of it, perfectly recognizable, was published in 1622.

Valenciennes' genus *Rhipidigorgia* was originally proposed to include all gorgonians with anastomosing branches. The characters used for generic distinction in the time of Valenciennes were necessarily the gross morphological features which could be observed without complex optical devices. The importance of the calcareous spicules had not even been guessed, and as a result it can now be recognized that the original concept of *Rhipidigorgia* included at least three genera as distinguished by modern methods. The three groups of species include (1) *Rhipidigorgia umbraculum* [now in *Gorgonella*]; (2) *R. stenobrochis*, *arenata* and *cribrum* [usually placed in *Gorgonia*]; and (3) *R. flabellum*, *coarctata* and *occatoria* [considered to be *Rhipidigorgia* s.s.]. An eighth species, *R. laqueus* Valenciennes (a *nomen nudum*), is still unrecognizable even as to genus, although according to Milne Edwards and Haime (1857) it may be *Gorgonia sasappo* var. *reticulata* Esper (= *Echinogorgia pseudo-sasappo* Kölliker). Verrill in 1864 shifted *R. umbraculum* to the genus *Gorgonella*, and in 1868 made *R. flabellum* (L.) the type of the original Linnaean *Gorgonia*. This procedure left *Rhipidigorgia* with only three species, *R. stenobrochis*, *arenata* and *cribrum*. When Bielschowsky in 1918, apparently unaware of Verrill's earlier action, considered *R. flabellum* as the type species of *Rhipidigorgia*, she restricted the generic concept to include only those forms with reticulating branches and scaphoid spicules and made it synonymous with the Linnaean *Gorgonia* as restricted by Verrill. Valenciennes' remaining species, *R. stenobrochis*, *arenata* and *cribrum* have therefore been excluded from all described gorgoniid genera. Although *R. stenobrochis* at various times has been placed in *Leptogorgia*, *Litigorgia* and *Eugorgia*, those genera as limited by the designation of their type species cannot include these three orphan species and the related forms subsequently described by Verrill and Hickson.

These reticulate gorgoniids lacking scaphoid spicules therefore require a new genus, for which the name *Pacifigorgia* is here proposed.

**Pacifigorgia**, n. gen.

*Rhipidigorgia* (part) Valenciennes, 1855, C. R. Acad. Sci. Paris **41**: 13; Verrill, 1864, Bull. Mus. Comp. Zool. **1**: 32 (part).

*Litigorgia* (part) + *Eugorgia* (part) Verrill, 1868, Amer. Journ. Sci. **45**: 414.

*Leptogorgia* (part) Verrill, 1869, Amer. Journ. Sci. **48**: 420.

*Gorgonia* Bielschowsky, 1918, Revis. Gorg.: 32; Kükenthal, 1919, Wiss. Ergeb. deutschen Tiefsee-Exped. **13** (2): 852; Kükenthal, 1924, Das Tierreich **47**: 338; Bielschowsky, 1929, Zool. Jahrb. Supp. 16: 141; Deichmann, 1936, Mem. Mus. Comp. Zool. **53**: 174.

**Diagnosis.**—Colony flabellate, branched in one plane; the twigs regularly anastomosing to form a close network. Zocids retracting within low verrucae or flush with the surface of the coenenchyma; anthocodial armature of more or less flattened rods usually present. Spicules of the coenenchyma are girdled spindles, including: long, more or less pointed forms with several belts of warts; and short, blunt forms with only 2–4 belts of warts (“double heads”).

**Genotype.**—*Gorgonia stenobrochis* Valenciennes = *Pacifigorgia stenobrochis* (Val.), n. comb., here designated.

**Remarks.**—This genus includes all those reticulate forms from the west coast of Central and South America previously known as *Gorgonia*. Except for one species from Trinidad and Brazil (*P. elegans* (Duch. & Mich.) = *Gorgonia hartii* Verrill), *Pacifigorgia* is confined to the eastern Pacific, from the Gulf of California to Peru. The generic name is chosen to indicate this predominantly Pacific distribution of the genus.

**Pacifigorgia irene**, n. sp.

Figs. 2, 3

*Leptogorgia adamsii* (part) Verrill, 1868, Trans. Connecticut Acad. **1**: 391.

*Gorgonia media?* Bielschowsky, 1918, Revis. Gorg.: 38; 1929, Zool. Jahrb., Supp. 16: 147.

*Gorgonia media* Galtsoff, 1950, Special Sci. Rep. U. S. Fish and Wildlife Serv. 28: 27.

**Diagnosis.**—The colonies form large, broad, finely reticulate fans crossed by several very stout main branches which can be followed to within 2 or 3 cm of the free edge. Zooids occur chiefly along the outer edges of the anastomosed twigs, and are retractile within small, often bilabiate verrucae. Spicules of the coenenchyma are long, pointed spindles 0.1–0.13 mm long, and short, blunt “double heads” up to 0.075 mm long; these sclerites are red, yellow or colorless. Anthocodial armature a weak crown of flat “rods” with broadly scalloped edges, reaching

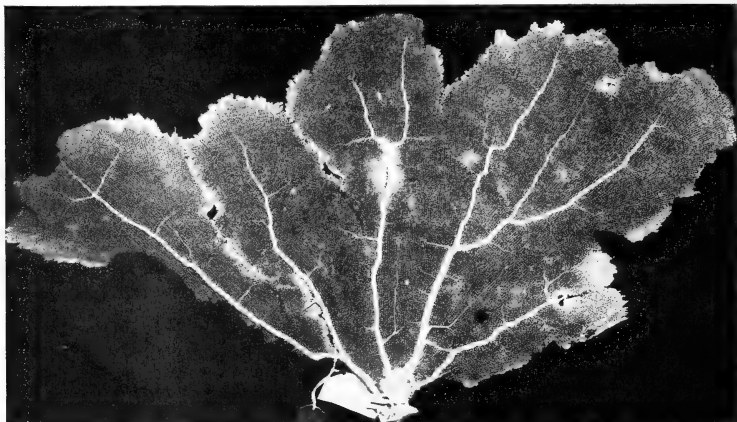

FIG. 2.—*Pacifigorgia irene*, n. gen., n. sp. The holotype, about one-fourth natural size.



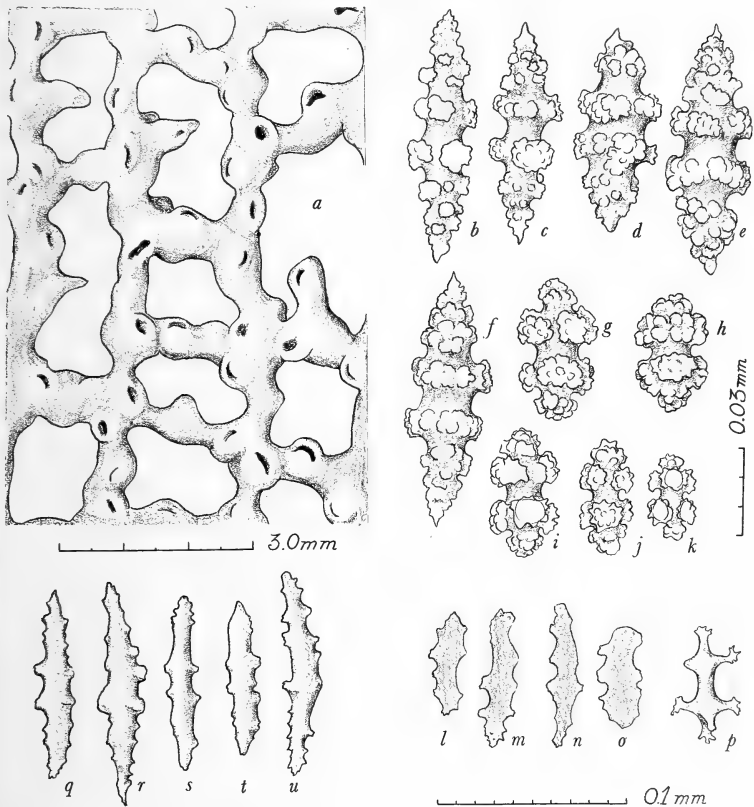

FIG. 3.—a-p, *Pacifigorgia irene*, n. gen., n. sp.: a, Detail of branching; b-f, long spindles; g-k, short spindles or "double heads"; l-o, flat, anthocodial sclerites; p, small capstan from anthocodia. q-u, *Pacifigorgia adamsi* (Verrill): Anthocodial sclerites. 3.0-mm scale applies to a only; 0.03-mm scale to p only; 0.1-mm scale to all others.

0.05 mm in length, and small, spindly capstans about 0.04 mm long; these spicules are usually colorless, but a few may be tinted pink. Color of colony rusty purplish red.

*Description*.—The type is a broad, flat fan about 35 cm high and 63 cm broad. (A part of the colony has been cut away, and its total width probably exceeded 70 cm.) The twigs are very slender, closely and regularly anastomosed to form a network of small, squarish meshes 1.5-2.0

mm in diameter. Several stout main branches flattened in the plane of ramification arise from the base and radiate outward across the fan, branching occasionally and diminishing in diameter slowly, losing themselves in the meshwork only 2 or 3 cm from the edge of the colony. Zooids do not occur on the flat outer faces of the midribs, but are found in a row along the line where the twigs are given off on either side. The anastomosing twigs are flattened at right

angles to the plane of the fan, and along their outer edges the zooids form small, hemispherical, often bilabiate verrucae; two zooids usually occur on the tips of the free, unanastomosed twig ends, which are up to 5 mm in length. The color of the colony is a rusty purplish red, fading to an ochre yellow in some places along the edge of the fan.

The spicules of the coenenchyma are of two types: (1) long, pointed spindles with a prominent naked girdle and 4-6 belts of warts, reaching 0.13 mm in length; and (2) short, blunt spindles or "double heads" also with a median naked space, but with only two belts of warts and terminal tufts, reaching about 0.075 mm. The coenenchyma spicules are usually red, but a few are colorless. In the yellow areas of the colony they are mostly pale yellow. The spicules of the anthocodia are flat rods with widely scalloped margins, reaching about 0.05 mm in length. These spicules are almost always colorless, but a few may be tinted with pink. There are also a few weak, long-armed capstans, which are colorless.

*Holotype*.—U.S.N.M. no. 49365. Punta Pajaron, Panama, lat. 7° 55' N., long. 81° 38' W.; March 11, 1948, Paul S. Galtsoff, collector.

*Records*.—Golfo de Nicoya, Costa Rica; March 1927, M. Valerio, collector (49379); Costa Rica no definite locality (33611).

*Remarks*.—*Pacificorgia irene* is perfectly distinct from *P. adamsii* (Verrill), with which it was originally included. Verrill's remarks about "adult specimens" (1868, Trans. Connecticut Acad. 1:391) refer to this species. The several specimens of *P. adamsii* in the Museum of Comparative Zoology and those in the U. S. National Museum are uniformly small colonies, as are a number of the original specimens in Verrill's collection in the Peabody Museum at Yale University. Unfortunately, the latter have not been available for spicular examination, but all are of such uniform outer appearance that I have no hesitation in considering them the same. The mesh of *P. adamsii* is about the same as that of the new species, but it lacks any trace of strong midribs, and the color is purple or yellow rather than the rusty purplish red characteristic of *P. irene*. In addition, the anthocodial spicules of the two species are distinct. Those of *P. irene* are flat, broad, and almost always colorless; those of *P. adamsii* are round or but little flattened, slender, longer than those of *P. irene*, and almost always clear, pale yellow. Figures of the anthocodial spicules from both species

are given in order to make the differences clear. The coenenchymal spicules differ less, but seem to be a little longer in *P. adamsii*.

The specific name is chosen from the Greek word *εἰρήνη*, peace, in keeping with the derivation of the generic term *Pacificorgia*.

#### Genus *Pterogorgia* Ehrenberg

*Gorgonia* (part) Pallas, 1766, Elench. Zooph.: 160.

*Pterogorgia* (part) Ehrenberg, 1834, Abh. Königl. Akad. Wiss. Berlin 1832 (pt. 1): 368. [Type *G. anceps* Pallas, subs. des.: Milne Edwards and Haime, 1850, Brit. Foss. Corals: lxxx.]

*Xiphigorgia* (part) Milne Edwards and Haime, 1857, Hist. nat. corall. 1: 171; Kükenthal, 1916, Zool. Jahrb., Suppl. 11: 491 (part); Bielschowsky, 1918, Revis. Gorg.: 62; Kükenthal, 1924, Das Tierreich 47: 357 (part); Deichmann, 1936, Mem. Mus. Comp. Zool. 53: 200. [Type, *G. anceps* Pallas, subs. des.: Bielschowsky, 1918, Revis. Gorg.: 62.]

*Diagnosis*.—Colonies more or less richly branched, mostly laterally; branches strongly compressed, triangular, or square; zooids in longitudinal furrows on the edges of rather high, thin coenenchymal ridges running along two, three or four sides of the stems and branches. Zooids small; anthocodial armature a weak crown consisting of 8 tracts of flattened rods. Coenenchyma with stout, strongly warted spindles and blunt scaphoids.

*Genotype*.—*Gorgonia anceps* Pallas (by subsequent designation: Milne Edwards and Haime, 1850, Brit. Foss. Corals: lxxx).

*Remarks*.—This genus includes three certain and one doubtful species, all Antillean. The valid species are:

#### *Pterogorgia anceps* (Pallas)

*Corallina fruticosa, ramulis & cauliculis compressis, quaquaversum expansis, purpureis elegantissimis* Sloane, 1707, Voyage to Jamaica: 57, pl. 22, fig. 4.

*Gorgonia anceps* Pallas, 1766, Elench. Zooph.: 183; Verrill, 1869, Amer. Journ. Sci. 48: 425.

*Pterogorgia anceps* Ehrenberg, 1834, Abh. Königl. Akad. Wiss. Berlin 1832 (pt. 1): 369.

*Gorgonia (Pterogorgia) anceps* Dana, 1846, U. S. Expl. Exped. 7: 648.

*Xiphigorgia anceps* Milne Edwards and Haime, 1857, Hist. nat. corall. 1: 172; Kükenthal, 1924, Das Tierreich 47: 357 (part); Deichmann, 1936, Mem. Mus. Comp. Zool. 53: 201.

This is the common, large, purple or yellowish species with branches square or triangular in cross section. Its branches are never so broad and flat as in *P. guadalupensis* Duchassaing and Michelin.

**Pterogorgia citrina** (Esper)

*Gorgonia citrina* Esper, 1792, Pflanzthiere **2**: 129, pl. 38; Verrill, 1869, Amer. Journ. Sci. **48**: 425.

*Pterogorgia fasciolaris* + *P. Sancti Thomae* Ehrenberg, 1834, Abh. Königl. Akad. Wiss. Berlin 1832 (pt. 1): 369.

*Gorgonia (Pterogorgia) citrina* Dana, 1846, U. S. Expl. Exped. **7**: 648.

*Pterogorgia citrina* Duchassaing and Michelotti, 1860, Mém. corall. Antill.: 30.

*Xiphigorgia citrina* Verrill, 1864, Bull. Mus. Comp. Zool. **1**: 33; Kükenthal, 1924, Das Tierreich **47**: 358, fig. 182; Deichmann, 1936, Mem. Mus. Comp. Zool. **53**: 201.

This is the familiar, small *Pterogorgia* with flat branches, usually yellow with purple edges, sometimes all purple.

**Pterogorgia guadalupensis** Duchassaing and Michelin

*Pterogorgia guadalupensis* Duchassaing and Michelin, 1846, Rev. Zool. Soc. Cuvierienne **9**: 218.

*Xiphigorgia guadalupensis* Duchassaing and Michelotti, 1860, Mém. corall. Antill.: 33.

*Gorgonia guadalupensis* Verrill, 1869, Amer. Journ. Sci. **48**: p. 425.

*Xiphigorgia anceps* (part) Kükenthal, 1924, Das Tierreich **47**: 357.

Specimens collected in the Gulf of Mexico during the first and second University of Miami Marine Laboratory Gulf of Mexico Sponge Investigations 1947 and 1948, by Dr. F. G. Walton Smith and J. Q. Tierney, have convinced me that Duchassaing and Michelin's species is perfectly distinct and worthy of recognition. I have been unable to find specimens of *P. anceps* which grade into it, either in the large series in the U. S. National Museum or among specimens in the field. A complete redescription will be published at a later date.

The specimens of *P. guadalupensis* examined agree perfectly with Duchassaing and Michelotti's figure. The species is readily distinguished from *P. anceps* by its very much broader, flat branches which are never triolate. Part of a specimen is shown in the accompanying key-figure 9, compared with *P. anceps*.

A situation similar to that involving *Gorgonia* and *Rhipidigorgia* exists between *Pterogorgia* Ehrenberg and *Xiphigorgia* Milne Edwards and Haime. In short, the genus *Pterogorgia* of Ehrenberg, like many other early genera, was a polyphyletic assemblage, and its species can now be divided into at least two modern genera, ap-

portioned as follows: (1) *P. setosa* Esper, *acerosa* [Pallas?] Ehrenberg, *stricta* Ehrenberg, *turgida* Ehrenberg; and (2) *P. fasciolaris* Ehrenberg (= *citrina* Esper, var.?), *sancti-thomae* Ehrenberg (? = *citrina* Esper), *anceps* Pallas, and *violacea* Ehrenberg non Pallas [? = *anceps*]. Ehrenberg also assigned questionably *Gorgonia americana* Gmelin, *sanguinolenta* Pallas [both *fide* Cuvier], and *pinnata* L. [*fide* Gmelin] to his *Pterogorgia*, without having seen specimens. Milne Edwards and Haime in 1850 designated *P. anceps* (Pallas) as the type species of *Pterogorgia*, thereby restricting the genus to the second group mentioned above. Completely disregarding the restriction which they themselves had imposed, these authors created in 1857 a new genus, *Xiphigorgia*, which included *Gorgonia anceps*, and this usage became generally accepted. This was undoubtedly due in no small part to the fact that the latter arrangement was proposed in their well-known *Histoire naturelle des coralliaires*, whereas the earlier restriction of *Pterogorgia* was made in the introduction to their *Monograph of the British fossil corals*, a work holding little interest to the student of recent Gorgonacea. Consequently, Verrill overlooked the delimitation of *Pterogorgia* and proposed *P. acerosa* (Pallas) as the type species of Ehrenberg's genus; this procedure, which applied the name *Pterogorgia* to the first of the two groups mentioned above, subsequently came into general acceptance. The generic limits of *Xiphigorgia* were established by Miss Bielschowsky when she designated (1918) *X. anceps* as its type, but she failed to perceive that it was then absolutely synonymous with *Pterogorgia* s.s. and that half of the original *Pterogorgia* species were not referable to any described genus. This situation has remained unchanged, and the species eliminated from *Pterogorgia* still require a genus to include them, for which I propose the name *Antillogorgia*.

**Antillogorgia**, n. gen.

*Pterogorgia* (part) Ehrenberg, 1834, Abh. Königl. Akad. Wiss. Berlin 1832 (pt. 1): 368; Milne Edwards and Haime, 1857, Hist. nat. corall. **1**: 167 (part); Bielschowsky, 1918, Revis. Gorg.: 52; Kükenthal, 1924, Das Tierreich **47**: 351; Bielschowsky, 1929, Zool. Jahrb., Suppl. **16**: 197; Deichmann, 1936, Mem. Mus. Comp. Zool. **53**: 193.

*Diagnosis*.—Colonies mostly bushy, with the secondary branching in one plane; numerous

twigs arranged along the main branches in close pinnate order, sometimes with secondary twigs; stem and branches round or flattened; twigs round, or more frequently somewhat compressed. Zooids small, not producing verrucae, usually arranged in two rows along the edges of the twigs; they sometimes occur in rows on the large branches and main stems. Anthocodia either unarmed or with small, more or less flattened rods arranged in 8 triangles to form a weak crown. Coenenchyma spicules are scaphoids and spindles in the outer layer, spindles alone in the inner.

*Genotype.*—*Gorgonia acerosa* Pallas = *Antillogorgia acerosa* (Pallas), n. comb., here designated.

*Remarks.*—This genus is apparently confined to the Antillean region. Its species form one of the most conspicuous elements of the littoral marine fauna along the reefs of Florida and in the West Indies. The most abundant species, at least on the Florida coast, is *Antillogorgia acerosa* (Pallas). For a description, see Deichmann, 1936, Mem. Mus. Comp. Zool. 53: 198. It is usually dark purple when alive. *A. ellisiana* (Milne Edwards and Haime) and *A. americana* (Gmelin) are not uncommon in the same regions. The living colonies are usually brownish purple.

#### Genus *Phyllogorgia* Milne Edwards and Haime

*Gorgonia* (part) Esper, 1791, Pflanzenziere 2: 1.  
*Gorgonia* (*Pterogorgia*) (part) Dana, 1846, U. S. Expl. Exped. 7: 647.

*Phyllogorgia* Milne Edwards and Haime, 1850, Brit. Foss. Corals: lxxx. [Type, *Gorgonia dilatata* Esper.]

*Hymenogorgia* Valenciennes, 1855, C. R. Acad. Sci. Paris 41: 13. [Type, *Gorgonia quercus folium* Ehrenberg = *Gorgonia dilatata* Esper.]

*Phyllogorgia* Verrill, 1912, Journ. Acad. Nat. Sci. Philadelphia (2)15: 393.

*Diagnosis.*—Colonies branched in one plane, the branches forming broad, flat leaves; axis anastomosing. Zooids small, without verrucae, on all surfaces of the leaves. The spicules are stout spindles and scaphoids.

*Genotype.*—*Gorgonia dilatata* Esper (by original designation).

*Remarks.*—The single species, *P. dilatata*, is found on the coast of Brazil. The single early record of its occurrence at Guadeloupe has not been confirmed.

#### Genus *Leptogorgia* Milne Edwards and Haime

*Gorgonia* (part) Pallas, 1766, Elench. Zooph.: 160; Milne Edwards and Haime, 1857, Hist. nat. corall. 1: 157 (part).

*Leptogorgia* (part) Milne Edwards and Haime, 1857, Hist. nat. corall. 1: 163. [Type, *G. viminalis* Milne Edwards and Haime = *G. viminalis* Esper = *Leptogorgia longiramosa* Kükenthal 1924; subs. des.: Verrill, 1868, Trans. Connecticut Acad. 1: 387.]

*Lophogorgia* (part) Milne Edwards and Haime, 1857, Hist. nat. corall. 1: 167. [Type, *G. flamea* Ellis and Solander.]

*Litigorgia* (part) Verrill, 1868, Amer. Journ. Sci. 45: 414. [Type, *L. florum* Verrill; subs. des.: Verrill, 1868, Trans. Connecticut Acad. 1: 387.]

*Eugorgia* (part) Verrill, 1868, Amer. Journ. Sci. 45: 414.

?*Pseudopterogorgia* Kükenthal, 1919, Wiss. Ergeb. deutschen Tiefsee-Exped. 13 (2): 854. [Type, *Leptogorgia australiensis* Ridley, 1884.]

*Asperogorgia* Stiasny, 1943, Vid. Medd. Dansk naturh. Foren. 107: 92. [Type, *L. radula* (Möbius).]

*Diagnosis.*—Colonies mostly branched in one plane, lateral or pinnate, occasionally dichotomous, rarely bushy; branches and twigs somewhat flattened but never greatly expanded to form lamellar ridges. Zooids in two lateral tracts along the sides of twigs and branches, fully retractile or forming low verrucae; anthocodial armature of most rods or spindles usually present. Coenenchyma with girdled spindles but no modified forms.

*Genotype.*—*Gorgonia viminalis* Milne Edwards and Haime (by subsequent designation: Verrill, 1868, Trans. Connecticut Acad. 1: 387).

*Remarks.*—Bielschowsky's designation of *G. petelchizans* Pallas as the type of *Leptogorgia* could have no standing even if it had priority, since that species was not included within the genus as originally constituted.

*Leptogorgia* contains many species in temperate and tropical waters, and although it is represented practically around the world, the center of distribution seems to be in the neighborhood of the west coast of Central America.

The characters ordinarily used for separating *Lophogorgia* from *Leptogorgia*, the flattened branches and arrangement of zooids all around the branches and twigs, are so variable as to be useless for generic distinctions. Round as well as flattened branches may occur in the same colony, and the biserial zooid distribution can

be found with little difficulty. Furthermore, specimens of *Leptogorgia* which are typical in all other respects may have zooids distributed all around the twigs. The presence of distinct verrucae, the feature used by Stiasny to distinguish his *Asperogorgia* species from the other Lophogorgias (which he considered as part of *Leptogorgia*), is no more reliable. I have therefore placed both these genera in the synonymy of *Leptogorgia*.

Kükenthal's *Pseudopterogorgia* (1919) was created on the strength of some supposed "klamern" in four Indo-Pacific species. An examination of the original description and figures of the type species, *P. australiensis* (Ridley), suggests that Ridley's original generic assignment of the species (*Leptogorgia*) was correct. The spicules are all described as fusiform, and while one of the individuals figured is a little curved, it is not a very convincing scaphoid. I am therefore tentatively synonymizing the genus and referring its species back to *Leptogorgia*.

#### Genus *Phycogorgia* Milne Edwards and Haime

*Gorgonia* Valenciennes, 1846, Voyage of the *Venus*, Atlas of Zool., Zoophytes: pl. 11, fig. 2.  
*Phycogorgia* Milne Edwards and Haime, 1850, Brit. Foss. Corals: lxxx. [Type, *Gorgonia fucata* Valenciennes.]  
*Phycogorgia* Kükenthal, 1924, Das Tierreich 47: 359.

*Diagnosis*.—Colonies bushy, the stems and branches strongly flattened and frondose, arising from a spreading base. Axis lamellar. Zooids small, completely retractile and without armature, on the fronds and on the base. Spicules are small, blunt, girdled spindles.

*Genotype*.—*Gorgonia fucata* Valenciennes, 1846 (by original designation).

*Remarks*.—Only one species is known, occurring in shallow water from Mazatlán to Chile.

#### Genus *Eugorgia* Verrill

*Lophogorgia* (part) G. Horn, 1860, Proc. Acad. Nat. Sci. Philadelphia 12: 233.  
*Gorgonia* (part) Verrill, 1864, Bull. Mus. Comp. Zool. 1: 33.  
*Eugorgia* (part) Verrill, 1868, Amer. Journ. Sci. 45: 414. [Type, *E. ampla* Verrill; subs. des.: Verrill, 1868, Trans. Connecticut Acad. 1: 386.]  
*Eugorgia* Verrill, 1868, Trans. Connecticut Acad. 1: 406; Bielschowsky, 1929, Zool. Jahrb., Supp. 16: 170.

*Diagnosis*.—Branching chiefly in one plane, lateral or dichotomous, sometimes bushy. Zooids in biserial longitudinal rows, usually without anthocodial armature, with or without low verrucae. The spicules are ordinary spindles, together with disk spindles produced by the more or less complete fusion of the warts of the median 2 or 4 belts to form disks.

*Genotype*.—*Leptogorgia ampla* Verrill (by subsequent designation; Verrill, 1868, Trans. Connecticut Acad. 1: 386).

*Remarks*.—Although *Eugorgia* is now an exclusively west American genus, two Atlantic gorgoniids are apparently related to it. *Leptogorgia virgulata* Lamarek and *L. setacea* (Pallas) have spicules identical with the poorly developed disk spindles and intermediate forms to be found in a number of *Eugorgia* species. They may be relict species of a once widespread *Eugorgia*, or only *Leptogorgias* developing along *Eugorgia* lines. It remains for future study to determine which is actually the case.

#### ILLUSTRATED KEY TO THE GENERA OF THE FAMILY GORGONIIDAE

A<sup>1</sup>. Spicules as spindles of various forms, some of which may occasionally be slightly bent, but never as true scaphoids, or "half-moon"-shaped spicules:

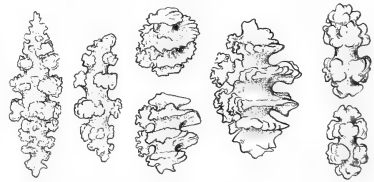

B<sup>1</sup>. Branches and twigs not coalescent, but free and usually slender:

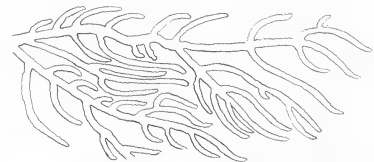

C<sup>1</sup>. Spicules only regular spindles: *LEPTOGORGIA*.

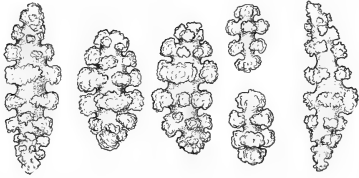

C<sup>2</sup>. Spicules include spindles with warts more or less completely fused to form disks: EUGORGIA.

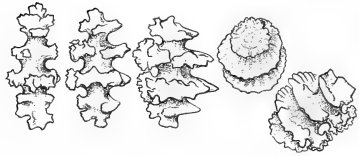

B<sup>2</sup>. Branches and twigs coalescing to form a regular meshwork: PACIFIGORGIA.

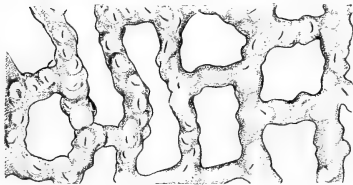

B<sup>3</sup>. Branches and twigs flat, foliate: PHYCORGIA.



A<sup>2</sup>. Scaphoid spicules present in addition to simple spindles:

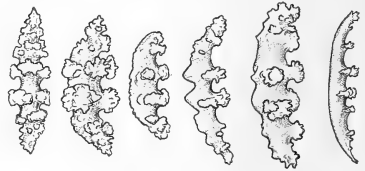

B<sup>1</sup>. Branches and twigs not coalescent, but free and usually slender:

C<sup>1</sup>. Branching closely pinnate, the twigs slender, round or only slightly compressed: ANTILLOGORGIA.

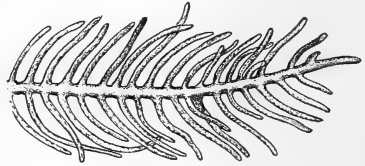

C<sup>2</sup>. Branching not closely pinnate; branches and twigs with two, three, or four longitudinal, thin, coenenchymal lamellae, causing them to be flat and blade-like, triangular, or square in cross section: PTEROGORGIA.

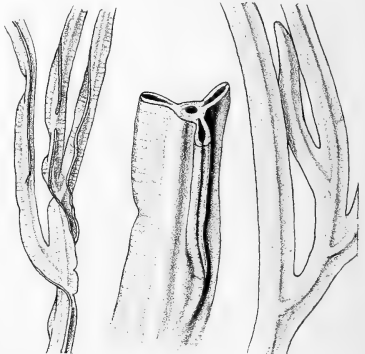

B<sup>2</sup>. Branches and twigs coalescing to form a regular network: GORGONIA.



B<sup>3</sup>. Branches and twigs flat, foliate: PHYLLOGORGIA.

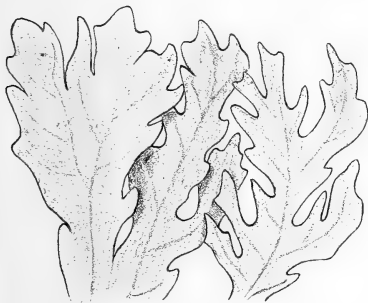

#### LITERATURE CITED

- BIELSCHOWSKY, EVA. *Eine Revision der Familie Gorgoniidae*. Inaugural-Dissertation zur Erlangung der Doktorwürde der Hohen Philosophischen Fakultät der Schlesischen Friedrich-Wilhelms-Universität zu Breslau: 1-66. Breslau, 1918.
- . *Die Gorgonarien Westindiens. Kap. 6, Die Familie Gorgoniidae*. Zool. Jahrb., Suppl. 16, Heft 1: 63-234, 40 figs., pls. 2-5. 1929.
- CLUSIUS, CAROLUS. *Exoticorum libri decem: quibus animalium, plantarum, aromatum, aliorumque peregrinorum fructuum historiae describuntur*: [10] 1-378 [5], illus. Antverpiae, 1605.
- DANA, JAMES DWIGHT. *Zoophytes*. U. S. (Wilkes) Exploring Expedition during the years 1838, 1839, 1840, 1841, 1842, 7: i-vi + 1-740, 45 figs., atlas of 61 col. pls. 1846.
- DEICHMANN, ELISABETH. *The Alcyonaria of the western part of the Atlantic Ocean*. Mem. Mus. Comp. Zool. 53: 1-317, pls. 1-37. 1936.
- DUCHASSAING DE FONBRESSIN, PLACIDE, and MICHELIN, HARDOUN. *Note sur deux polyptiers de la famille des coraux appartenant aux genres Solanderia et Pterogorgia*. Rev. Zool. Soc. Cuvierienne 9: 218-220. 1846.
- and MICHELOTTI, JEAN. *Mémoire sur les coralliaires des Antilles*: 1-88, pls. 1-10. Mem. Reale Acad. Sci. Torino, ser. 2, 19: 279-365, pls. 1-10. 1860.
- EHRENBERG, CHRISTIAN GOTTFRIED. *Beiträge zur physiologischen Kenntniss der Corallenthiere im allgemeinen, und besonders des rothen Meeres, nebst einem Versuche zur physiologischen Systematik de selben*. Abh. Königl. [preussischen] Akad. Wiss. Berlin 1832 (pt. 1): 225-380. 1834.
- ELLIS, JOHN. *An essay towards the natural history of the corallines, and other marine productions of the like kind, commonly found on the coasts of Great Britain and Ireland*: i-xvii + [5 lvs] 1-103, pls. 1-37 [38]. London, 1755.
- ESPER, EUGENIUS JOHANN CHRISTOPH. *Die Pflanzenthiere in Abbildungen nach der Natur mit Farben erleuchtet nebst Beschreibungen 1-3*: i-xii + 1-320; 1-220; 1-285+; *Fortsetzung 1-2*: 1-230; 1-48, 428 pls. Nürnberg-1788-1850. [The parts dealing with gorgonians were published as follows: Vol. 2, pp. 1-96, 1791; pp. 97-180, 1792; pp. 181-220, 1793. pp. 221-304, 1799; Fortsetzung, vol. 1, pp. 117-168, 1796; pp. 169-230, 1797.]
- GALTSOFF, PAUL SIMON. *The pearl oyster resources of Panama*. U. S. Fish and Wildlife Service Special Scientific Report: Fisheries no. 28: 1-53, 28 figs. 1950.
- HORN, GEORGE. *Descriptions of three new species of Gorgoniidae, in the collection of the Academy*, Proc. Acad. Nat. Sci. Philadelphia 12: 233. 1860.
- KÜKENTHAL, WILLY. *Die Gorgonarien Westindiens. Kap. 2, Über den Venusfächer; Kap. 3, Die Gattung Xiphigorgia H. M. Edw. Zool. Jahrb., Suppl. 11, Heft 4: 485-503, 13 figs., pl. 23. 1916.*
- . *Gorgonaria*. Wissenschaftliche Ergebnisse der deutschen Tiefsee-Expedition auf dem Dampfer *Valdivia* 1898-99, 13 (2): 1-946, 318 figs., pls. 30-89. 1919.
- . *Gorgonaria*. Das Tierreich 47: i-xxviii + 1-478, 209 figs. 1924.
- LINNÉ, KARL VON. *Systema naturae*, ed. 10, 1: [2] 1-824. Holmiae, 1758.
- LOCHNER VON HUMMELSTEIN, JOHANN HEINRICH. *Rariora musei Besleriani quae olim Basilius et Michael Rupertus Besleri collegerunt*: [12] 1-112, pls. 1-40. Norimbergae, 1716.
- MILNE EDWARDS, HENRI, and HAIME, JULES. *A monograph of the British fossil corals. Part 1. Introduction; corals from the Tertiary and Cretaceous formations*: i-lxxxv + 1-71, pls. 1-11. London, 1850.
- . *Histoire naturelle des coralliaires ou polyptiers proprement dits*: 1-3, pp. i-xxxv + 1-326; 1-633; 1-560; atlas of 36 pls. Paris, 1857.
- OLEARIUS, ADAM. *Gottorfische Kunst-Kammer*: [5 lvs.] 1-80, pls. 1-37. Schlesswig, 1674.
- PALLAS, PETER SIMON. *Elenchus zoophytorum sistens generum adumbrationes generatioris et specierum cognatarum succinctas descriptiones cum selectis auctorum synonymis*: i-xvi + 1-451. Hagae-Comitum, 1766.
- SLOANE, HANS. *A voyage to the islands Madera, Barbados, Nieves, S. Christophers and Ja-*

- maica, with the natural history of the herbs and trees, four footed beasts, fishes, birds, insects, reptiles & c. of the last of those islands . . .* 1: [7 pls] i-cliv + 1-264, pls [4] 1-156. London, 1707.
- STIASNY, GUSTAV. *Gorgonaria von Panama*. Vidensk. Medd. Dansk naturh. Foren. 107: 59-103, figs. 1-16. 1943.
- VALENCIENNES, ACHILLE. In A. Dupetit-Thouars, *Voyage autour du monde sur la frégate la Vénus, pendant les années 1836-1839*. Atlas de Zoologie: Zoophytes: pls. 1-15. Paris, 1846.
- . *Extrait d'une monographie de la famille des Gorgonidées de la classe des polypes*. Comptes Rendus Séances Acad. Sci. Paris 41: 7-15. 1855.
- VERRILL, ADDISON EMERY. *List of the polyps and corals sent by the Museum of Comparative Zoölogy to other institutions in exchange, with annotations*. Bull. Mus. Comp. Zool. 1: 29-60. 1864.
- . *Review of the corals and polyps of the west coast of America*. Trans. Conn. Acad. Arts and Sciences 1: 377-567, pls. 5-10. 1868-71. [Actual dates of publications are: pp. 377-390, April 1868; pp. 391-398, June 1868; pp. 399-414, July 1868; pp. 415-422, December 1868; pp. 423-454, January 1869; pp. 455-478, February 1869; pp. 479-502, March 1869; pp. 503-518, April 1870; pp. 519-534, Nov. 1870; p. 567, February 1871.]
- . *Critical remarks on halcyonoid polyps in the museum of Yale College, with descriptions of new genera*. Amer. Journ. Sci. 45: 411-415. 1868.
- . *Critical remarks on halcyonoid polyps, no. 3*. Amer. Journ. Sci. 48: 419-429. 1869.
- . *The gorgonians of the Brazilian coast*. Journ. Acad. Nat. Sci. Philadelphia (2) 15: 373-404, 1 fig., pls. 29-35. 1912.

MALACOLOGY.—*Recent species of the veneroid pelecypod Arctica*.<sup>1</sup> DAVID NICOL, U. S. National Museum.

The study represented by this paper is the third in a series on living relict pelecypods. In comparison with *Fimbria* and *Cucullaea*, the living species of *Arctica* is well known, and many good studies have been made on it in several northern Atlantic regions. The shellfish surveys of Rhode Island and Massachusetts have recently obtained valuable information on the ecology of the genus, and it is possible that *Arctica* will soon assume commercial importance as an edible clam. There have, however, been few attempts to make a complete study of the living species. The latest review of *Arctica* is that of Lamy (1920, pp. 260-265).

*Arctica*, first appearing in the early Cretaceous, has apparently always been confined to temperate waters. Since the Cenozoic the genus has been confined to Europe and the north Atlantic regions. At present there is one living species, confined primarily to the north Atlantic.

*Arctica* has been placed in many different superfamilies. On the basis of shell characters *Arctica* most closely resembles some of the brackish water genera, as for example *Batissa*. Among the living marine pelecypods *Arctica* resembles the veneraceans. The lack of a pallial sinus and the development of

posterior lateral teeth are morphologic characters present in *Arctica* but not in the veneraceans.

Family ARCTICIDAE Newton, 1891

Genus *Arctica* Schumacher, 1817

*Venus* Linné, 1767 (in part).  
*Pectunculus* da Costa, 1778 (in part).  
*Cyclas* Link, 1807, not *Cyclas* Bruguière, 1798.  
*Cyprina* Lamarck, 1818.  
*Armida* Gistel, 1848, not *Armida* Risso, 1826.  
*Cypriniadea* Rovereto, 1900.

Genotype: *Arctica vulgaris* Schumacher, 1817 = *Venus islandica* Linné, 1767 (monotypy).

In 1752 Moehring used the name *Arctica* for a genus of birds, but this work and the translation published in 1758 have been suppressed (see opinion 5, vol. 1, pt. 14, 1944, pp. 115-126). Schumacher's genus name *Arctica*, published in 1817, can thus be used. Lamarck applied the French vernacular term *Cyprine* in 1812 but did not use the name *Cyprina* until 1818.

*Arctica islandica* (Linné), 1767

Figs. 1-3

1767. *Venus islandica* Linné, Syst. Nat., ed. 12, 1 (pt. 2): 1131.  
 1777. *Venus mercenaria* Linné, Pennant, British zoology 4, Mollusca: 94, pl. 53, fig. 47.  
 1778. *Pectunculus crassus* da Costa, British conchology: 183, 184, pl. 14, fig. 5.

<sup>1</sup> Published by permission of the Secretary of the Smithsonian Institution.



1778. *Venus buccardium* Born, Rerum naturalium Musei Caesarei Vindobonensis, pt. 1, Testacea: 49, 50.
1780. *Venus buccardium* Born, Rerum naturalium Musei Caesarei Vindobonensis, pt. 1, Testacea: 63, pl. 4, fig. 11.
1798. *Venus islandica* Linné, Röding, Museum Boltenianum: 180, no. 284.
1798. *Venus feröensis* Röding, Museum Boltenianum: 180, no. 285.
1807. *Cyclas islandica* (Linné), Link, Beschreibung Rostock Sammlung: 150.
1817. *Arctica vulgaris* Schumacher, Essai nouveau système habitations vers testacés: 145, 146, pl. 13, figs. 3a, b.
1818. *Cyprina islandica* (Linné), Lamarek, Animaux sans vertèbres 5: 557, 558.
1830. *Cyprina vulgaris* (Schumacher), James Sowerby, Genera of Recent and fossil shells, *Cyprina*: pl. 67.
1903. *Cyclas islandica* (Linné), Dall, Tertiary fauna of Florida: 1500-1502.
1910. *Cyprina islandica* var. *inflata* Odhner, Ark. för Zool. 7 (4): 19, figs. 33, 34.
1920. *Cyprina islandica* (Linné), Lamy, Journ. Conchyl. 64 (4): 262-265.

A more complete synonymy is given by Lamy (1920, pp. 262-264) and need not be repeated here.

*Description*.—Shell porcellaneous, often chalky, periostracum black, light brown, or rarely reddish-brown in color, light brown on small shells, smooth except for raised concentric lines; ornamentation consists of concentric lines of growth; valve outline subcircular, equivalve, subequilateral, not gaping; beaks prosogyrate; ligament opisthodontic, parivincular, external, connected to the periostracum; hinge formula  $\frac{AI\ AIII\ 3a\ 1\ 3b\ PI}{AII\ 2a\ 2b\ 4b\ PII}$ , cyrenoid; pallial line integripalliate, adductor muscle scars subequal; interior ventral border smooth.

*Measurements in mm.*—

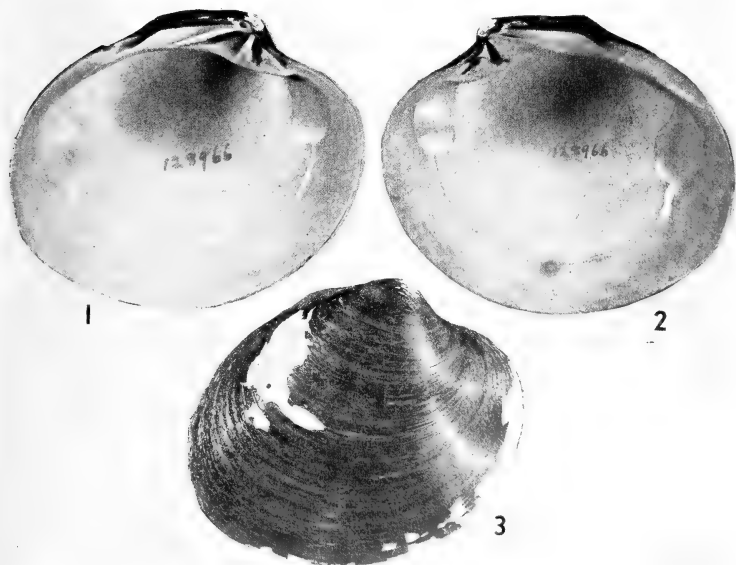

FIGS. 1-3.—*Arctica islandica* (Linné), U.S.N.M. no. 128966a: 1, Interior, left valve; 2, interior, right valve; 3, exterior, right valve. All figures  $\frac{2}{3}$  natural size.

U.S.N.M. no.	Length	Height	Convexity (both values)
201566a	106.4	100.5	61.9
34431	99.1	95.5	51.3
201566	97.3	92.2	59.1
102047	96.1	92.0	56.3
34431a	92.9	86.2	42.5
461553	85.4	78.0	47.0
27256a	82.6	76.7	41.4
304728a	81.7	76.5	48.3
201577	80.0	78.0	43.3
128966a	77.5	70.2	37.0
225762	76.9	68.7	39.5
225764a	75.3	67.6	40.1
128966b	74.6	69.5	34.8
461553a	67.8	62.5	34.0
128966c	67.8	62.4	33.7
128966	62.3	56.5	30.6
27258b	61.2	55.8	33.7
225764c	58.8	54.3	30.3
225764b	52.8	46.5	24.8
272258a	45.9	40.0	23.7
499954a	44.4	40.3	22.3
45985	44.3	41.1	22.6
45991	42.1	38.2	22.8
181970a	41.4	36.7	19.8
35666	39.6	36.2	21.4
158995	23.9	21.3	13.3
40146b	21.0	19.4	10.0
40146a	17.8	16.1	9.0
153164a	12.0	10.4	5.9
153164	8.4	8.0	4.5

The above measurements seem to indicate no tendency toward more convex shells in northern waters or cooler bottom temperatures. There may be, however, some relationship between the type of substrate and convexity, the more convex shells being found on the muddier bottoms. More data are necessary to ascertain whether any relationship exists between living conditions and shape of shell.

*Number of specimens.*—There are approximately 1,000 specimens of *Arctica islandica* in the collection of the United States National Museum. Many of the specimens are small shells obtained by dredging.

*Locality data.*—Specific localities are so numerous that it is not practical to list each one, and general information on geographical distribution is sufficient for this problem.

#### GEOGRAPHICAL DISTRIBUTION AND ECOLOGY OF *ARCTICA ISLANDICA* (LINNÉ)

This species has been mentioned in most faunal lists of mollusks taken from northern Atlantic localities. Despite these considerably extensive observations, the distribution of living *Arctica islandica* is not well known.

There have been several great temperature fluctuations in the northern Atlantic during the Pleistocene and post-Pleistocene, and collectors have taken shells and recorded them in faunal lists, although *Arctica islandica* might not be living in some of those areas today. Accurate locality information on living specimens, furthermore, is the most important criterion for interpreting climatic conditions during Pliocene, Pleistocene, and post-Pleistocene times.

*Arctica* occurs as far south as Cape Hatteras, N. C., but is quite rare from there northward to Long Island Sound. Along the coasts of Rhode Island, Massachusetts, and Maine, *Arctica* is abundant. It is frequently found in the Bay of Fundy, Halifax Harbor, and Northumberland Strait. There are a few records of *Arctica* in Chaleurs Bay and off the southern coast of Newfoundland. A few valves of *Arctica* have been collected off the coasts of Labrador and Greenland, but these are believed to be subfossil (Jensen, 1912, p. 90). The genus is abundant on the coasts of Iceland, the Faroes, the Shetlands, the British Isles, and the coast of Norway. *Arctica* also occurs off the Kola Peninsula and in the White Sea. There are a few records of shells collected north and east of the White Sea as far as Novaya Zemlya, but these shells are probably also subfossil. There are reports of *Arctica* occurring as far as Bornholm Island in the Baltic Sea, but shells from the Baltic are generally rather thin, and the reduced salinity probably prevents the genus from living farther north and east in the Baltic region. *Arctica islandica* is abundant along the coast of northern France. South of Brittany *Arctica* is rarely reported, but it has been found as far south as the Bay of Cadiz. Occurrences in the Mediterranean are probably all subfossil.

*Arctica* is a boreal but not an arctic genus. It can not live for probably more than a few hours in waters which go below 0°C. Arcisz et al. (1945, p. 15) recorded *Arctica* living at 0.7°C. Perhaps for this reason the genus is not circumpolar and is not found in the coldest waters of the Atlantic Ocean. On the other hand, the highest temperature which *Arctica* can withstand is about 19°C.

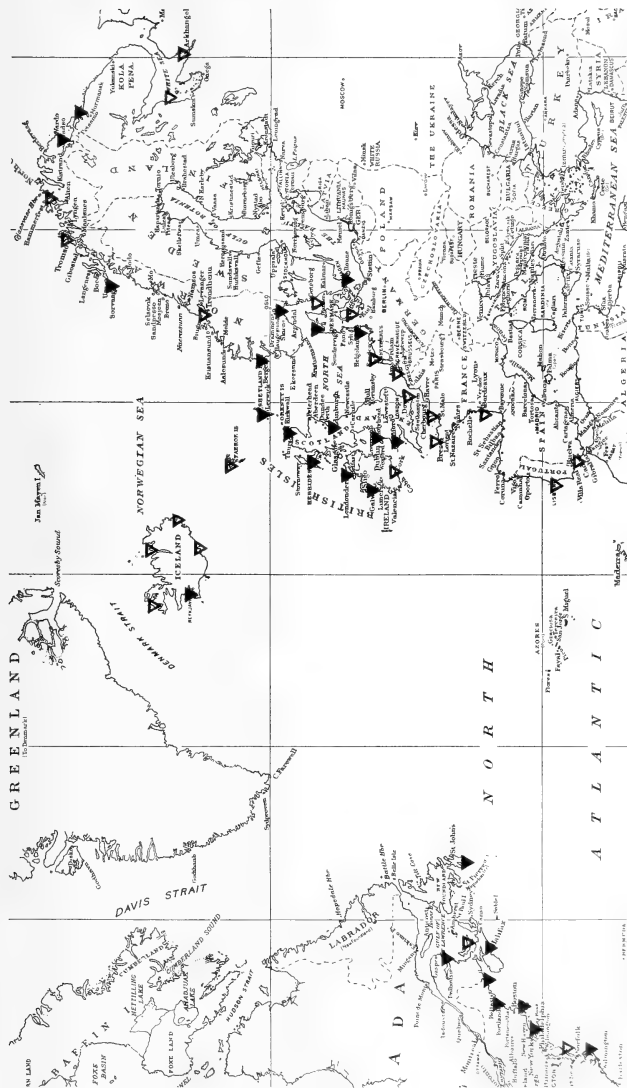

FIG. 1. Map showing distribution of living specimens of *Arctica islandica* (Linneé): ▼, Locality data based on U. S. National Museum specimens; ▽, locality data based on specimens in other museums and on published records.

Recent observations on living specimens by Turner (1949, pp. 15, 16) have shown that *Arctica* is always found on sandy mud or mud bottoms, although Madsen (1949, p. 50) claimed that in Iceland the genus is found on ooze, mud, clay, sand, gravel, and shell bottoms. It can be said with certainty, however, that *Arctica* is nearly always found on sandy mud or mud bottoms, and this statement is based on many observations by many workers.

I have recorded 98 dredging stations, ranging from Halifax to Cape Hatteras, where *Arctica* was taken by the U. S. Bureau of Fisheries. The greatest depth from which *Arctica* was dredged was 482 meters; the next greatest depth was 360 meters. The remaining 96 stations were at depths of 281 meters or less, and one station was only 13 meters in depth. Contrary to some observations made in the past, the small shells were not found at the greater depths, and large and small shells seemed to be found at all recorded depths. In the Firth of Forth the genus has been collected alive at the lowest of low tides (Forbes and Hanley 1853, p. 445). Generally, however, it is most commonly found at depths from 10 to 280 meters, but it is occasionally found as deep as 500 meters. Off the coast of Rhode Island, Arcisz et al. (1945, p. 9) found the greatest concentration of the genus at depths ranging from 25 to 45 meters and did not find living specimens in less than 18 meters of water. In colder water *Arctica* apparently is abundant at shallower depths.

Reports of young shells of *Arctica* having been taken in more than 1,000 meters of water should be reinvestigated. A specimen from the Jeffrey's collection (no. 201564) is labeled *Cyprina islandica* L. (fry), taken from the northwest coast of Ireland at a depth of 1,215 fathoms. This tiny specimen is almost impossible to identify, but it does not appear to be *Arctica*.

*Acknowledgments.*—I am greatly indebted to William J. Clench, of the Museum of Comparative Zoölogy at Harvard College, for information on geographical distribution, and to Harry J. Turner, Jr., of the Woods Hole Oceanographic Institution, for valuable data on the ecology of *Arctica*.

## REFERENCES

- ARCISZ, W., NEVILLE, W. C., DEWOLF, R. A., and LOOSANOFF, V. L. *The ocean quahog fishery of Rhode Island*: 31 pp., 10 figs. Dept. Agriculture and Conservation, Rhode Island, 1945.
- COSTA, E. M. DA. *The British conchology*: 254 pp., 17 pls. London, 1778.
- DALL, W. H. *Contributions to the Tertiary fauna of Florida*. Trans. Wagner Free Inst. Sci. **3** (pt. 6): 1219-1654, pls. 48-60. 1903.
- . *Note on Cyprina islandica*. Proc. Malacol. Soc. London, **10** (pt. 4): 286. 1913.
- FORBES, E., and HANLEY, S. *A history of British Mollusca and their shells* **1**: 486 pp., 64 pls., London, 1853.
- GISTEL, J. *Naturgeschichte des Thierreichs für höhere Schulen*: 216 pp., 32 pls. Stuttgart, 1848.
- HEMMING, F. *Opinions and declarations rendered by the International Commission on Zoological Nomenclature (Opinion 5, The status of certain pre-Linnean names reprinted subsequent to 1757)* **1** (pt. 14): 115-126. London, 1944.
- JENSEN, A. S. *Studier over nordiske Mollusker. II, Cyprina islandica*. Naturh. Forening Kjobenhavn Vid. Medd. 1902: 33-42.
- . *Lamellibranchiata (part 1), The Danish Ingolf-Expedition 2* (5): 119 pp., 5 figs., 4 pls. Copenhagen, 1912.
- LAMARCK, J. B. *Histoire naturelle des animaux sans vertèbres* **5**: 612 pp. Paris, 1818.
- LAMY, E. *Révision des Cypricardiacea et des Isocardiacea vivants du Muséum d'Histoire naturelle de Paris*. Journ. Conchyl. **64** (4): 259-307. 1920.
- LINK, H. F. *Beschreibung der Naturalien-Sammlung der Universität zu Rostock*: 1-165, 1-30, 1-38, 1-38. Rostock, 1806-1808.
- LINNÉ, K. VON. *Systema naturae*, ed. 12, **1** (pt. 2): 533-1327. Holmiae, 1767.
- MADSEN, F. J., *The zoology of Iceland* **4** (pt. 63, Marine Bivalvia): 166 pp., 12 figs. Copenhagen and Reykjavik, 1949.
- ODHNER, NILS. *Marine Mollusca in the collections of the Swedish State Museum*, Ark. för Zool. **7** (4): 31 pp., 1 pl. 1910.
- ROVERETO, G. *Illustrazione dei molluschi fossili Tongriani*, etc. Atti Reale Univ. Genova **15**: 31-210, 9 pls. 1900.
- SCHUMACHER, C. F. *Essai d'un nouveau système des habitations des vers testacés*: 287 pp., 22 pls., Copenhagen, 1817.
- SMITH, E. A. *On the generic name to be applied to the Venus islandica*, Linn. Proc. Mal. Soc. London **10** (pt. 2): 105, 106. 1912.
- TURNER, H. J., JR. *Report on investigations of methods of improving the shellfish resources of Massachusetts*: 22 pp., 5 figs. Commonwealth of Massachusetts, 1949.

ICHTHYOLOGY.—*Chromis atripectoralis*, a new damselfish from the tropical Pacific, closely related to *C. caeruleus*, family Pomacentridae. ARTHUR D. WELANDER and LEONARD P. SCHULTZ.

During our studies of some Bikini fishes at the University of Washington, Seattle, we were surprised to observe that the blue-green damselfish, which occurs so abundantly in shallow waters of the reefs throughout the tropical Indo-Pacific faunal area, was a complex of two species. This paper describes one of these as new and presents data for the separation of the two species.

*Chromis atripectoralis*, n. sp.

*Chromis caeruleus* (in part), Jordan and Seale, Bull. U. S. Bur. Fish. 25 (1905): 290, pl. 46, ? fig. 1. 1906 (Samoan Islands; color descriptions for specimens numbered 2, 4, and 6, with pectoral axil black appear to be this new species); Montalban, Pomacentridae of the Philippine Islands, Monog. Bur. Sci. Manila, no. 24: 35, pl. 8, fig. 2. 1927 (Philippine Islands).

*Heliastes lepidurus* Günther, Fische der Südsee, Journ. Mus. Godeffroy 15 (pt. 7): 238 (in part), pl. 128, fig. C.1881.

*Holotype*.—U.S.N.M. no. 112397, Bikini Atoll, Eman Island, channel reef, July 17, 1947, S-46-405, Schultz, Brock, Hiatt and Myers, standard length 87 mm.

*Paratypes*.—The following paratypes are from Guam in the Marianas Islands: U.S.N.M. no. 124104, Tumon Bay, July 10, 1945, R. H. Baker, 48 specimens, 9 to 25 mm; U.S.N.M. no. 152557, Tumon Bay, December 10, 1945, L. Gressitt, 2 specimens, 48 mm; U.S.N.M. no. 152558, Tumon Bay, January 8, 1946, Gressitt and Ingram, 35 specimens, 37 to 60 mm.

The following paratypes are from the Marshall Islands: U.S.N.M. no. 141041, Bikini Atoll, Eman Island, July 17, 1947, S-46-405, Schultz, Brock, Hiatt, and Myers, 5 specimens, 61 to 76 mm; U.S.N.M. no. 112395, Rongerik Atoll, Latoback Island, June 28, 1946, S-46-238, Schultz and Herald, 11 specimens, 23 to 44 mm; U.S.N.M. no. 112396, Rongelap Atoll, Naen Island, July 30, 1946, S-46-302, Herald, 33 specimens, 30 to 70 mm; U.S.N.M. no. 141038, Eniwetok Atoll, Aaraanbiru Island, June 3, 1946, S-46-198, Schultz, 8 specimens, 28 to 67 mm; Chicago Nat. Hist. Mus. no. 44703, Bikini Island, August 14, 1946, S-46-349, Herald, 20 specimens, 22 to 65 mm; C.N.H.M. no. 44704, Rongelap Atoll, Eni-

aetok Island, July 20, 1946, S-46-267, Herald and Brock, 11 specimens, 31.5 to 61 mm; C.N.H.M. no. 44705, Rongerik Atoll, Latoback Island, August 14, 1946, S-1041, Schultz, Brock, and Donaldson, 2 specimens, 31 to 49 mm.

The following paratypes are from the Philippine Islands, collected by the *Albatross*: U.S.N.M. no. 96435, Langao Point, Luzon, June 24, 1909, 1 specimen, 70 mm; U.S.N.M. no. 152552, Little Santa Cruz Island, May 28, 1908, 2 specimens, 69 to 74 mm; U.S.N.M. no. 152551, Dodepo Island, Celebes, November 19, 1909, 1 specimen, 49 mm; U.S.N.M. no. 96455, Tamahu Island, December 12, 1909, 1 specimen, 71 mm; U.S.N.M. no. 96427, Tara Island, December 14, 1908, 2 specimens, 52 and 64 mm; U.S.N.M. no. 152549, Alimango Bay, Burias Island, March 5, 1909, 1 specimen, 63 mm; U.S.N.M. no. 152550, Makyan Island, November 29, 1909, 1 specimen, 69 mm; U.S.N.M. no. 96460, Port Palapag, June 3, 1909, 2 specimens, 61 mm; U.S.N.M. no. 152553, Bubuan Island, Jolo, February 14, 1908, 2 specimens, 47 and 57 mm; U.S.N.M. no. 152548, Langao Point, Luzon, June 24, 1909, 4 specimens, 47 to 66 mm; U.S.N.M. no. 96423, Port Palapag, June 3, 1909, 1 specimen, 49 mm; U.S.N.M. no. 96410, Pararongpang Island, June 11, 1909, 5 specimens, 47 to 65 mm; U.S.N.M. no. 96473, Mactan Island, Cebu, March 25, 1909, 1 specimen, 82 mm; U.S.N.M. no. 96440, Limbones Cove, February 8, 1909, 1 specimen, 49 mm; U.S.N.M. no. 96434, Candaraman Island, January 4, 1909, 1 specimen, 64 mm; U.S.N.M. no. 96477, Biri Channel, June 1, 1909, 1 specimen 59 mm; U.S.N.M. no. 96437, Biri Channel, June 1, 1909, 2 specimens, 59 and 61 mm; U.S.N.M. no. 96432, Philippines, 1 specimen, 50 mm; U.S.N.M. no. 96447, Guntao Island, December 20, 1908, 1 specimen, 52 mm; U.S.N.M. no. 96453, Lippo Point, Belagam Bay, June 18, 1908, 1 specimen, 31 mm; U.S.N.M. no. 96469, Maculabo Island, June 14, 1909, 1 specimen, 48 mm; U.S.N.M. no. 96452, Sabalayan, Mindoro, December 12, 1908, 1 specimen, 47 mm; U.S.N.M. no. 96468, Port Langan, Palawan Island, April 8, 1909, 1 specimen, 38 mm; U.S.N.M. no. 152547, Candaraman Island, Balabac, June 4, 1909, 1 specimen, 47 mm.

The following paratypes were collected in var

ious localities: U.S.N.M. no. 152554, Fiji Islands, 1 specimen, 37 mm.; U.S.N.M. no. 72715, Java, collected by Bryant-Palmer, 1 specimen; U.S.-N.M. no. 65463, Manga Reva, February 4, 1905, *Albatross*, 26 specimens, 38 to 70 mm; U.S.-N.M. no. 152555, Samoan Islands, Jordan and Kellogg, 5 specimens, 43 to 80 mm; U.S.N.M. no. 152556, Samoan Island, Tutuila Island, Pago Pago Bay, June 2, 1939, 11 specimens, 39 to 59 mm.

The following paratypes were collected by the University of Washington group in the Marshall Islands: Eniwetok Atoll, Rigili Island, July 24, 1948, 1 specimen, 47 mm; Eniwetok Atoll, Rigili Island, August 10, 1949, Welander, 1 specimen, 53 mm; Bikini Atoll, Ion Island, August 7, 1947, 1 specimen, 62 mm; Bikini Atoll, Airy Is'and, August 14, 1947, 1 specimen, 57 mm; Bikini Atoll, Amen Island reef, July 31, 1947, 1 specimen, 77 mm; Bikini Island, August 1, 1946, 5 specimens 60 to 77 mm, Bikini Island, July 24 1947, depth 33 feet, 13 specimens, 36 to 83 mm; Likiep Atoll, Likiep Island, August 22, 1949, 11 specimens, 27 to 52 mm; Rongerik Atoll, Latoback Island, August 16, 1947, 1 specimen, 28 mm.



FIG. 1.—*Chromis atripectoralis*, n. sp., a black and white print of a kodachrome picture taken of the holotype at Bikini.

*Description*.—Dorsal fin rays XII, 9 or 10 (usually 10); anal II, 9 or 10 (usually 10); pectorals ii, 16 to 19 (usually 17 or 18); pelvics I, 5; branched caudal rays 7 + 6; transverse scale rows 24 to 27 from upper edge of gill opening to base of caudal rays; 2 between lateral line and origin of dorsal, 9 between lateral line and origin of anal; dorsal lateral line with 15 or 16 tubular scales; gill rakers on first gill arch, 6 to 9 + 1 + 19 to 22, total 28 to 31.

Depth of body 2.0 to 2.2, length of head 3.1 to 3.6, both in standard length (tip of snout to base of middle caudal rays); snout 3.5 to 4.0, eye 2.8 to 3.3, least preorbital width 7.0 to 8.0, length of upper jaw 2.5 to 2.9, postorbital part of head (hind margin of eye to upper edge of gill opening)

2.2 to 2.5, interorbital width 2.9 to 3.1, least depth of caudal peduncle 2.0 to 2.3, length of pectoral fin 1.2 to 1.3, length of pelvic fin 1.2 to 1.3, length of second dorsal spine 2.0 to 2.3, length of upper caudal rays 0.6 to 1.0, lower 0.7 to 0.9, all in length of head (tip of snout to posterior margin of opercular membrane); depth of caudal peduncle into length of caudal peduncle 1.1 to 1.4; angle of upper profile with lengthwise axis of body 33° to 48°, profile straight to convex.

Teeth of jaws conical, widely spaced, an outer row enlarged teeth, in lower jaw these projecting anteriorly near symphysis, a few teeth at sides near tip of lower jaw curve out posteriorly; inner teeth minute in single row in upper jaws, forming small patches of very minute teeth on either side of symphysis in lower jaw; snout scaled to tip, line from eye, including nostril and along upper edge of preorbital naked; preorbitals and suborbitals scaled, lower margin of latter almost entirely obscured; preopercle produced at angle, its posterior margin entire with some irregular crenulations observable at angle in many specimens; no scales on bases of soft dorsal and anal; upper and lower caudal rays filamentous, 3 free spines on upper and lower caudal base; profile angle, measured with one side of angle lying along closed lower jaw to tip of snout and the other side from snout to nape directly above gill opening, 80° to 96°.

*Color in alcohol*.—Head and upper half of body bluish gray to brown; lower sides and belly lighter, pale to silvery; a narrow dark to bluish line from eye, just under nostril toward middle of snout along naked area; iris faintly bluish; spiny dorsal membrane more or less dusky, this sometimes accentuated basally and distally, spines dusky; lips, especially at tips of jaws dusky to black; soft dorsal and anal rays dusky, membranes lighter; upper and lower caudal rays brownish, middle rays dusky basally, pale distally; pelvics pale to dusky; pectorals pale except at base where upper rays are dusky to blackish, axil of pectoral with large black blotch, this broadest on dorsal portion and usually not extending to lower rays; in young less than 40 mm in standard length axil of pectoral dusky to black.

*Color when alive*.—Top of head and back bright bluish green; a narrow blue-green line across upper part of eye to snout and a second line from anterior margin of eye just below nostril to snout; lower half of head, sides of body and belly pure white or grayish white; spiny dorsal smoky pur-

plish; soft dorsal and anal rays dusky, membranes faintly yellowish; upper and lower caudal rays greenish, outer margins blackish, middle rays greenish on scaled portion, yellowish on naked portion, pelvics greyish; pectorals clear hyaline except upper ray dusky.

*Remarks.*—This new species may be differentiated from *C. caeruleus* on the basis of two striking characters: The black axil of the pectoral fin and by more branched pectoral rays (see table of counts) usually 17 or 18 in *atripectoralis*, whereas *caeruleus* usually has 15 or 16. The pectoral axil of *caeruleus* is pigmented with black dots forming a dusky area only along the dorsal part, thence fading ventrally where no pigment cells occur or only a few, whereas *atripectoralis*

has a black axil and the individual black pigment cells are not isolated when viewed under magnification, the outer edge of this black axil sharply contrasts with the pale distal part of the axil. On specimens shorter than about 30 mm. in standard length the axil is not quite as black as in longer specimens. We note that the distal margin of the spiny dorsal fin of *atripectoralis* may have a dusky to blackish line whereas that of *caeruleus* is pale.

Although most of the descriptions in the literature for these blue-green damsel fishes fail to mention the colorations of the pectoral axil, a few do so and show the spiny dorsal fin with a dark margin. We have listed a few such references in the synonymy.

TABLE 1.—COUNTS MADE ON TWO SPECIES OF CHROMIS

Species and locality	Number of fin rays																		Number of vertical scale rows crossing lateral line	Number of gill rakers on first arch								
	Dorsal			Anal			Pectoral													Above angle			At angle			Below angle		
	XII	9	10	II	9	10	ii	15	16	17	18	19	24	25	26	27	6	7		8	9	1	19	20	21	22	23	24
<i>C. caeruleus:</i>																												
Marshall Islands	18	3	15	18	42	8	32	2																				
Marianas Islands					22	3	15	4																				
Philippine Islands						16	2	13	1																			
Phoenix and Samoan Islands	6	1	5	6	1	5	3	1	2																			
Total	24	4	20	24	1	23	14	62	7																			
<i>C. atripectoralis:</i>																												
Marshall Islands	16	1	15	16	1	15	31		2	11	21	1	4	10	10	7	1	3	10	1	15		1	4	7	3		
Marianas Islands						21	1	4	16																			
Philippine Islands						16		8	8																			
Phoenix and Samoan Islands	4	4	4	2	2	5			4	1		1		1		1												
Total	20	1	19	20	3	17	73		3	23	40	2	4	11	10	8	1	3	10	1	15		1	4	7	3		

TABLE 2.—MEASUREMENTS RECORDED FOR TWO SPECIES OF CHROMIS (EXPRESSED IN THOUSANDTHS OF THE STANDARD LENGTH)

Measurements	<i>C. caeruleus</i> Bikini Atoll			<i>C. atripectoralis</i>				
				Bikini Atoll				Guam
	Paratype	Paratype	Paratype	Paratype	Paratype	Paratype	Holotype	Paratype
Standard length in millimeters	30.2	45.0	58.7	31.1	46.1	52.3	67	41.5
Greatest depth of body	464	449	477	462	475	470	455	458
Length of head	301	298	303	309	293	311	314	313
Length of snout	79	84	83	73	76	79	87	80
Diameter of eye	96	96	85	112	93	101	100	113
Least preorbital width	20	24	29	29	24	36	31	31
Length of upper jaw	99	113	114	116	117	122	112	120
Postorbital part of head	129	120	126	119	121	127	136	137
Interorbital width	86	84	99	103	91	105	90	101
Least depth of caudal peduncle	129	122	131	138	143	137	130	142
Length of pectoral fin	242	240	266	270	269	249	251	265
Length of pelvic fin	268	240	267	251	256	281	230	251
Length of third to sixth dorsal spine	162	140	150	132	154	135	149	147
Length of upper caudal rays	331	—	341	—	360	—	298	362
Length of lower caudal rays	331	—	310	338	321	324	403	386
Length of caudal peduncle	145	160	170	170	182	183	221	222

To the recognized *Chromis caeruleus* (Cuvier and Valenciennes) we refer the following named species: *Heliases caeruleus* Cuvier and Valenciennes, Histoire naturelle des poissons 5: 497. 1830 (New Guinea; Ulea); *H. frenatus*, ibid.: 498 (Guam); *H. lepisurus*, ibid.: 498 (New Guinea). *Heliases frenatus*, Sauvage, Histoire naturelle des poissons 16: 436, pt. 28, fig. 1. 1887 (Madagascar); *Chromis lepisurus* Bleeker, Atlas Ichthy. 9: pl. 403, fig. 7. 1877, and Nat. Verh. Holland. Maatsch. Wet. 2 (6): 164. 1877 (East Indies; Zanzibar; Andamans; Guam; Ulea). *Heliastes lepidurus* Günther, Catalogue of the fishes in the British Museum 4: p. 63, 1862 (Amboina; emended spelling for *H. lepisurus* Cuvier and Valenciennes); Day, Fishes of India 2: 389, pl. 82, fig. 1. 1877 (Andamans); Günther, Fische der Südsee, Journ. Mus. Godefroy 15 (pt. 7): 238

(in part), pl. 128, fig. D (only). 1881. *Glyphiodon anabatooides* Day, Proc. Zool. Soc. London 1870: 696. *Glyphiodon bandanensis* Bleeker, Nat. Tijdschr. Ned. Indie 2: 248. 1851 (Neira, Banda). *Chromis caeruleus* (in part), Jordan and Seale, Bull. U. S. Bur. Fish. 25 (1905): 290. 1906 (Samoa Islands; in a letter to Dr. Jordan, see p. 291, from Dr. Vaillant who examined the types of *caeruleus*, *frenatus* and *lepisurus*, all three are referred to a single species by him); Aoyagi, H., Biogeographica, Trans. Biogeog. Soc. Japan 4 (1): 186, fig. 14. 1941 (Japan).

Remarks.—Fowler and Bean, U. S. Nat. Mus. Bull. 100, 7: 31, 61. 1928, have proposed the subgenus *Hoplochromis* for *C. caeruleus*, characterized by having the "front edge of lower jaw with 6 short conic teeth flaring outward."

ICHTHYOLOGY.—A new genus and species of anacanthobatid skate from the Gulf of Mexico. HENRY B. BIGELOW and WILLIAM C. SCHROEDER.\* (Communicated by L. P. Schultz.)

In 1924 von Bonde and Swart<sup>1</sup> proposed a new genus *Anacanthobatis* for *Leiobatis marmoratus* von Bonde and Swart, a curious batoid from the Natal coast; skate-like in that its pelvic fins are so deeply concave outwardly that they are entirely subdivided with the anterior subdivision limblike, but differing from all typical skates in their perfectly naked skins and in lacking dorsal fins. A second new species, *dubia*, agreeing with *marmoratus* in naked skin and in filamentous prolongation of the snout, but differing from it in that the outer margins of the posterior subdivision of its pelvic fins are fused along their anterior one-half with the inner margins of the pectorals, was also referred to *Anacanthobatis* by von Bonde and Swart.<sup>2</sup> But the unique specimen seems to have lost most of its tail, so that the presence or absence of dorsal fins remains to be learned.

*Anacanthobatis* is included among the Dasyatidae by Barnard,<sup>3</sup> by Fowler,<sup>4</sup> and

by Smith.<sup>5</sup> But the nature of its pelvic fins seems to us to place it among the rajoids, as a separate family, Anacanthobatidae, because of its naked skin and lack of dorsal fins.

No batoid resembling *Anacanthobatis* was seen again until the autumn of 1950, when trawlings by the U. S. Fish and Wild Life Service vessel *Oregon* in the northern side of the Gulf of Mexico, off the Mississippi, yielded two specimens that agree with the South African *A. marmoratus* von Bonde and Swart in structure of pelvics, wholly naked skin, and long slender tail without dorsal fins, but with *A. dubia* von Bonde and Swart in the fact that the outer margins of the posterior subdivision of the pelvic fin is fused along the anterior two-thirds with the inner margin of the pectorals, which is not the case in *marmoratus*. But the Gulf of Mexico form differs from both *marmoratus* and *dubius* in that the end of the snout is expanded in leaflike form (Fig. 1).

The marginal fusion of pelvic fins with pectorals now established for two species is so unusual a character as to justify a new genus, for which we propose the name *Springeria*, in recognition of Stewart Spring-

\* Contribution no. 554 from the Woods Hole Oceanographic Institution.

<sup>1</sup> Mar. Biol. Surv. South Africa Rep. 3, spec. Rep. 5 [1922]: 18, pl. 23, and accompanying errata slip. 1924.

<sup>2</sup> Loc. cit., p. 19.

<sup>3</sup> Ann. South African Mus. 21: 79. 1925.

<sup>4</sup> U. S. Nat. Mus. Bull. 100, 13: 448. 1941.

<sup>5</sup> Sex fishes of southern Africa: 71. 1949.



er's productive studies of the elasmobranchs of Florida and the Gulf. And the curious shape of the snout equally necessitates a new species, which we name *folirostris* for obvious reasons.

**Springeria**, n. gen.

*Genotype*.—*Springeria folirostris*, n. sp.

*Generic characters*.—Snout either prolonged as

a simple filament, or expanded terminally in shape shown in Fig. 1, terminating in a soft filament; firm rostral cartilage extending to base of filament; outer margins of posterior lobes of pelvis united along first two-thirds of their length with inner margins of pectorals; inner margins of posterior pelvic lobes attached nearly to tips to sides of tail. Tail without lateral folds, its lower side as well as its upper side with caudal membrane. Pelvic transverse, its anterior

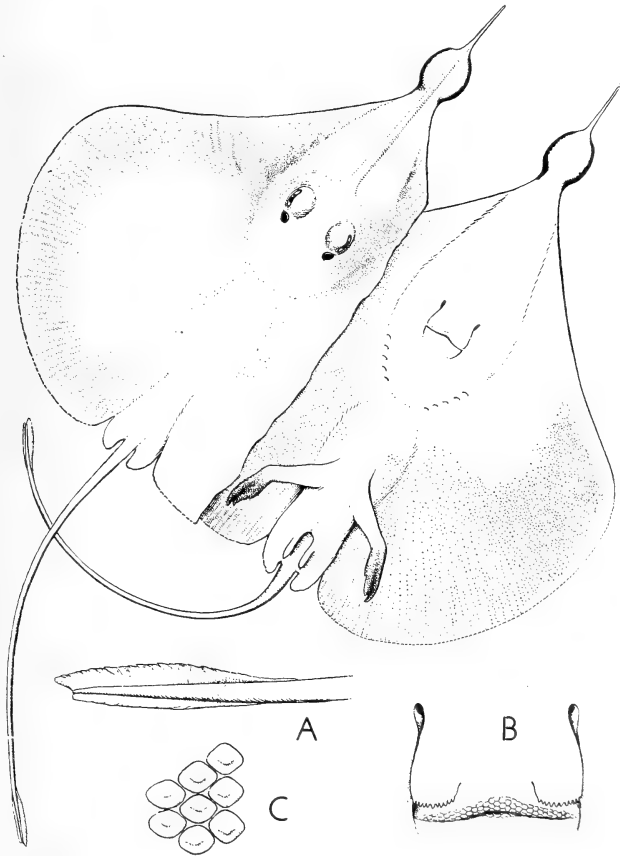

FIG. 1.—*Springeria folirostris*, n.sp., male, 400 mm long, holotype (U. S. N. M. no. 152546): A, End of tail, about  $\times 1.8$ ; B, mouth and nasal curtain, about  $\times 1.8$ ; C, three rows of teeth, upper, about  $\times 10$ .

profile slightly concave rearward, a long slender process at either end, directed forward, no radial cartilages along anterior half of basipterygial cartilages of pelvic fins.

*Species*.—Two species known, *S. folirostris*, n. sp., from the Gulf of Mexico, and probably also *duaia* von Bonde and Swart, 1924, South Africa.

***Springeria folirostris*, n. sp.**

*Study material*.—Immature male, 400 mm long to base of terminal filament; northern Gulf of Mexico off the Mississippi River, lat. 29° 02' N., long. 88° 34' W.; 232–258 fathoms; holotype, U. S. N. M. no. 152546; and very young male, 125 mm long, same general locality, lat. 29° 01' N., long. 88° 30' W., paratype, Museum of Comparative Zoology.

*Distinctive characters*.—*Springeria folirostris* differs from all other known batoids in the peculiar leaflike expansion of the end of its snout. Specimens with this and the tail damaged would still be easily separable from all other rajoids of the Atlantic by their perfectly naked skins; from all dasyatid and myliobatid rays by the nature of their pelvic fins.

*Description of type* (proportional dimensions in percent of total length).—Disc: Extreme breadth 51.6; length 55.3. Length of snout in front of orbits 21.8; in front of mouth 24.3. Orbits: Horizontal diameter 2.9; distance between 2.6. Spiracles: Length 1.0; distance between 5.1. Mouth: Breadth 4.5. Nostrils: Distance between inner ends 5.8. Gill openings: Lengths, first 0.75, third 0.75, fifth 0.50; distance between inner ends, first 9.2, fifth 4.8. Caudal fin: Length, base, upper 6.0, lower 5.0. Pelvis: Anterior margin 12.7. Distance from tip of snout<sup>6</sup> to center of cloaca 47.6; from center of cloaca to tip of tail 52.4.

Disc from base of terminal filament about 1.1 times as long as broad; maximum anterior angle from level of base of terminal expansion of snout to level of spiracles about 85°; end of snout expanded in leaflike form as shown in Fig. 1, terminating in a slender filament about as long as distance between spiracles. Margins of disc rearward from terminal expansion weakly concave about to level of spiracles, then altering to continuously and strongly convex around to very short inner margins without definite outer

<sup>6</sup> Exclusive of rostral filament, which is 23 mm long.

or posterior corners. Tail very slender, laterally compressed, increasingly so rearward; its width at axils of pelvic fins (where thickest) about as great as length of eye; its length from center of cloaca to tip about 1.1 times as great as distance from cloaca to base of terminal filament of snout. Skin perfectly naked everywhere, without dermal denticles of any sort. Snout in front of eyes about 8.4 times as long to base of terminal filament as distance between orbits, its length in front of mouth about 6.5 times as great as distance between exposed nostrils. Orbit about 1.1 times as long as distance between orbits, and nearly 3 (2.9) times as long as spiracle which is noticeably small. Nasal curtain conspicuously fringed, each side with 10–11 lobelets; outer margin of nostril only slightly expanded with irregular edge. Exposed nostril noticeably minute. Mouth on immature males a little arched forward, probably also on females, its shape not known for mature males. Teeth  $\frac{3}{2}$  on young male, low, with obscure cutting edge but no cusp, and arranged in quincunx. Teeth of mature males not seen. Gill openings minute; first about one-sixth as long as breadth of mouth; fifth about two-thirds as long as first; distance between inner ends of first gills about 1.6 times as long as between exposed nostrils, and between fifth gills about 1.9 times. No dorsal fins. Base of upper caudal fin-membrane about 1.0 times as long as distance between exposed nostrils, of shape illustrated (Fig. 1), its maximum width about one-tenth (about 9 percent) as great as length of its base; lower caudal membrane about half (55 percent) as wide as upper, its origin a little posterior to origin of upper; the two lobes discontinuous at tip of tail. Anterior leglike subdivision of pelvis nearly as long (95 percent) as from pelvic origin to rear corners, broader than thick, fleshy, with one articulation about midway its length, inner edge of the terminal segment scalloped, corresponding to tips of the three radial cartilages. Posterior lobe of pelvis with narrowly rounded rear corner reaching rearward only about as far as rear limits of disc; outer margin joined for about two-thirds its length to margin of pectoral, inner edge joined nearly to tip to side of tail.

Anterior rays of pectorals extending forward to a little posterior to base of terminal expansion of snout; firm rostral cartilage reaching about to base of terminal filament.

Color: Ash gray above, except unpigmented and translucent in spaces between rostral ridge and anterior rays of pectorals; orbits dusky, terminal expansion of snout narrowly and irregularly margined with black, also the posterior part of the back with a sooty blotch on one side near midline, perhaps the result of injury. Lower surface pale grayish white, the outer posterior belt of pectorals sooty gray, terminal expansion of snout narrowly and irregularly edged with black; tail sooty at base.

*Development stages.*—Presumably *Springeria* is oviparous like other rajids, but its eggs have not been seen yet.

*Size.*—How large this skate may grow is not

known, for the larger of the two specimens seen so far, 400 mm long to base of terminal filament, is an immature male, its claspers not yet reaching as far as the tips of its pelvics.

*Habits.*—The two specimens seen so far were trawled at 232–258 fathoms, this with the improbability that this skate would have been overlooked if it occurred in shallow water, suggests that it is confined to depths greater than about 200 fathoms. Nothing else is known of its habits.

*Range.*—So far known only in the northern side of the Gulf of Mexico off the Mississippi River, at the localities listed on page 112 under Study material.

ORNITHOLOGY.—*Race names in the Central American jay*, *Cyanolyca argentigula*. FRANK A. PITELKA, Museum of Vertebrate Zoology, University of California. (Communicated by H. G. Deignan.)

The silver-throated jay, *Cyanolyca argentigula*, is a species of restricted distribution in montane forests of Central America, and at present two rather well marked races are recognized, *C. a. argentigula* (Lawrence) in central Costa Rica and *C. a. blandita* Bangs in northern Panama. When Bangs (Proc. Biol. Soc. Washington 19: 109. 1906) described the latter from the Volcán de Chiriquí, he evidently did not see Lawrence's type of *argentigula* and assumed from Lawrence's description (Ann. Lyc. Nat. Hist. New York 11: 88. 1875) that the latter referred to specimens with white throats rather than to those with violet-gray throats. Specimens of the white-throated form, representing *argentigula* as now known, were then and are now more numerous in collections than specimens of the gray-throated form, *blandita*. Reading of Lawrence's description in the light of current knowledge of the two races will reveal that the original description, rather vague as regards critical details, suggests *argentigula* more than it does *blandita*. Ridgway's description (*Birds of North and Middle America*, pt. 3: 319. 1904), based on specimens from both northern Panama and central Costa Rica, applies to and includes both races as now recognized. From these considerations Bangs, in 1906, evidently described *blandita* on the assumption that Lawrence's name applied to the best-

known population, that of central Costa Rica. The type of *argentigula*, however, which I examined in Washington, D. C., in December 1949, so closely resembles the type of *blandita*, examined in Cambridge two months earlier, that both evidently represent one and the same race.

Interestingly enough, the basic facts concerning the type of *argentigula* were published in 1889 by Ridgway (Proc. U. S. Nat. Mus. 11: 541), when he compared it with specimens from the Volcán Irazú and stated: "Compared with the type [four adults] all have the throat-patch decidedly paler, its color being silvery white with a very faint purplish tinge, instead of light silvery grey, with a very strong tinge of purplish blue." Differences in the crown-band are also fully and correctly described by Ridgway. These are the differences used by Bangs to distinguish *blandita*.

There is ample evidence to support that provided by the types themselves. In the specimen register of the United States National Museum, the information on the type of *argentigula*, no. 67963, is as follows: Original number 320, female [inverted Venus's mirror sign on original label indicates female, as collector used usual sign for male], Talamanca, Costa Rica, received from William M. Gabb. In a subsequent entry, C. W. Richmond added the details that the speci-

men was collected by Juan Cooper, in May or June 1874. In Cooper's original catalogue, field numbers 315-320 are listed under the locality heading "En Camo," a phrase of unclear meaning (see beyond). Immediately following 320, however, is the locality heading "Cipurio" [=Sipurio]. Cooper's catalogue carries no dates, but the listing is chronological.

It seems clear that the type was obtained near Sipurio in southeastern Costa Rica, near the Panama border, and on the Caribbean slope of the Cordillera de Talamanca. From present-day knowledge of the altitudinal distribution of *C. argentigula*, we can say that the type was collected well above that lowland town. From a brief account published by Gabb in 1874 (*Amer. Journ. Sci.* 108: 388-390), it is known that in the course of a four months' journey into Talamanca, he reached the summit of Pico Blanco, a major peak above and south of Sipurio, on June 13 of that year. In another account, also written in 1874 (see pp. 267-286, *Geografía de Costa Rica*, by F. Montero Barrantes, Barcelona, 1892), Gabb outlines the route of his ascent between the ríos Urén and Lari, thence across the latter and upward to the summit. The descent was apparently made between the ríos Lari and Deparí, or at least to the northwest of the ascent.

Gabb was accompanied in Talamanca by Juan Cooper, and from Cooper's catalogue and probably other clues, Richmond deduced that the specimens listed under the heading "En Camo" were obtained in May or June 1874. "En Camo" probably means "en camino." The former is the only locality heading used by Cooper other than "Cipurio," which precedes and follows "En Camo."<sup>1</sup>

It thus seems very likely that Lawrence's type was collected near and more or less north of Pico Blanco, above Sipurio and probably in the drainage of the Río Lari. This may be considered the restricted type locality of *Cyanocitta argentigula* Lawrence. The geographic details are given on a map

<sup>1</sup> Gabb was a paleontologist, and I do not know of any evidence clearly indicating that some of the specimens credited to him (for example, by Goodwin, *Bull. Amer. Mus. Nat. Hist.* 87: 455. 1945) were collected by him personally.

accompanying Carriker's report on Costa Rican birds (*Ann. Carnegie Mus.* 6: 314-915. 1910), on which trails leading above Sipurio are indicated.

According to Goodwin (*Bull. Amer. Mus. Nat. Hist.* 87: 279. 1945), the major faunal break in the highland faunas of Costa Rica appears to follow the valley of the Río Reventazón, which, with the Río Grande de Tárcoles, separates the Cordillera Central (including Volcán Irazú and Volcán Turrialba) from the Cordillera de Talamanca. Faunal affinities of the latter range are to the south with Panama, at least among mammals (Goodwin, *loc. cit.*).

We now have these facts: The type of *argentigula* shares with *blandita* the pale violet-gray throat and crown-band coloration which Bangs used to distinguish the latter race from the former. Cooper obtained the type of *argentigula* in montane highlands continuous with those inhabited by *blandita* but separated from mountains inhabited by the white-throated race to the north. *Cyanolyca blandita* Bangs is thus a synonym of *Cyanocitta argentigula* Lawrence, and the name formerly applied to the northern race unfortunately must now be applied to the southern race, including, as it has not heretofore, the population of southern Costa Rica. The northern race, left without a name, may be known as—

*Cyanolyca argentigula albior*, n. name

*Type*.—Adult male, U. S. N. M. no. 209407, Volcán Turrialba, 9,680 feet, Costa Rica, March 28, 1908, collected by R. Ridgway and J. C. Zeledón, original number 582. Measurements of the type: Wing (chord), 118 mm; tail, 126; bill length (from nostril), 17.6; bill depth (at nostril), 10.1; tarsus, 35.3.

*Racial characters*.—Compared with *C. a. argentigula* of northern Panama and southern Costa Rica, throat lighter and less purplish (silvery white); transverse band on crown also lighter (silvery white), tinged marginally with pale lavender, but less brightly; supraauricular stripe lighter; wings and tail less purplish (Nigrosin Blue); size probably smaller (see table 1).

*Geographic distribution*.—Cordillera Central of Costa Rica [Volcán Irazú, Volcán Turrialba, La Hondura, Puente de Tierra, Retes, San Isidro de San José, and San Pedro (de Póas?)].

So far as I can determine now, other than Lawrence's type, none of the specimens of a total of 87 examined by me comes from the mountains of southern Costa Rica, south of the ríos Pirris and Reventazón. Six specimens bearing the locality "Limon," a Caribbean seaport, were not obtained there but elsewhere and possibly in the province of Limón, which includes the Talamanca district and the Caribbean slopes of the Talamanca Range. But the specimens from "Limon" resemble those from the Cordillera Central and are assigned to *C. a. albior*. Nevertheless, the possibility remains that intergradation of characters occurs at the north end of the Cordillera de Talamanca.

Acknowledgement is gratefully made to H. G. Deignan, United States National Museum, for

critical assistance in the preparation of this paper. Helpful suggestions were also received from J. L. Peters, Museum of Comparative Zoology. Specimens from the following collections were examined: American Museum of Natural History, British Museum, Carnegie Museum, Chicago Natural History Museum, H. O. Havemeyer, Museum of Comparative Zoology, Royal Ontario Museum of Zoology, United States National Museum, University of California (Dickey collection), and University of Michigan (Museum of Zoology). I am indebted to the curators and owners of these collections for their kind cooperation. This paper results from researches supported by a John Simon Guggenheim Fellowship held in 1949-50.

TABLE 1.—MEASUREMENTS OF ADULTS OF *CYANOLYCA ARGENTIGULA*

Race	Sex	Number of specimens	Range	Mean with standard error	Standard deviation <sup>1</sup>
<i>C. a. albior</i> :					
Wing.....	Males.....	31	112-123	118.2 ± 0.5	3.0
	Females.....	15	111-120	115.4 ± 0.8	3.0
Tail.....	Males.....	30	118-134	124.5 ± 0.8	4.1
	Females.....	14	116-126	121.4 ± 1.0	3.7
Bill length.....	Males.....	31	16.2-18.6	17.42 ± 0.10	0.57
	Females.....	15	15.8-18.7	16.80 ± 0.25	0.95
Bill depth.....	Males.....	31	8.8-10.1	9.31 ± 0.07	0.38
	Females.....	14	8.3- 8.9	9.14 ± 0.11	0.42
Tarsus.....	Males.....	32	32.7-35.7	34.15 ± 0.13	0.76
	Females.....	15	32.0-34.5	33.24 ± 0.18	0.70
<i>C. a. argentigula</i> :					
Wing.....	Males.....	6	119-127	121.8 ± 1.2	2.9
	Females.....	4	116-125	119.7	3.6
Tail.....	Males.....	6	122-141	129.5 ± 2.7	6.5
	Females.....	4	125-132	128.5	3.5
Bill, length.....	Males.....	6	17.1-18.6	17.80 ± 0.26	0.63
	Females.....	4	16.4-18.1	17.95	0.83
Bill, depth.....	Males.....	5	9.6-10.6	9.85 ± 0.17	0.39
	Females.....	4	9.0-10.2	9.70	0.55
Tarsus.....	Males.....	6	33.8-37.3	35.35 ± 0.62	1.52
	Females.....	4	32.1-35.2	33.95	1.42

<sup>1</sup> In samples of less than 30 specimens, N-1 was used in calculation of standard deviation.

## PROCEEDINGS OF THE ACADEMY

### 443d MEETING OF BOARD OF MANAGERS

The 443d meeting of the Board of Managers, held in the Cosmos Club on January 16, 1951, was called to order at 8:07 P.M. by the President, F. B. SILSBEE. Also present were: N. R. SMITH, H. S. RAPPLEYE, J. A. STEVENSON, H. A. REHDER, A. T. MCPHERSON, W. R. WEDEL, J. S. WILLIAMS, F. O. COE, F. A. WEISS, W. A. DAYTON, C. A. BETTS, R. S. DILL, E. W. PRICE, MARGARET PITTMAN, H. W. HEMPLE, F. M. SETZLER, and, by invitation, R. G. BATES, T. D.

STEWART, M. A. MASON, WALTER RAMBERG, and B. D. VAN EVERA.

The Committee on Membership submitted the names of four individuals proposed for resident membership. Seventeen persons previously proposed were elected, 14 to resident and 3 to non-resident membership.

The President announced that all arrangements had been completed for the Annual Meeting to be held at the Kennedy-Warren on January 18, 1951, at which time Dr. PER K. FROLICH would address the Academy.

The General Chairman of the Committee on Awards for Scientific Achievement, T. DALE STEWART, called upon WALTER RAMBERG, Chairman of the Engineering Sciences, to read the report of his Committee recommending SAMUEL LEVY, National Bureau of Standards, for the annual award in recognition of his distinguished service in the structural analysis of aircraft. Dr. Stewart then read the report by the Committee on Physical Sciences, which recommended PHILIP H. ABELSON, Department of Terrestrial Magnetism, in recognition of his distinguished service in the fields of chemistry, nuclear physics, and the physics of living organisms. Dr. Stewart read the report of the Committee on Biological Sciences, which recommended DAVID H. DUNKLE, U. S. National Museum, for recognition of his distinguished service in paleontology, especially by researches on early arthropods and teleost fishes.

The Board of Managers unanimously accepted and approved the recommendations of the Committee on Awards for Scientific Achievement.

B. D. VAN EVERA, Chairman of the Committee for the Teaching of Science, indicated that his Committee had decided that no award be made this year. Considerable discussion followed with regard to the difficulties in connection with the age limit as set by the rules of the Board and the advisability of increasing the number of recipients for these awards.

The Chairman of the Committee on the Encouragement of Science Talent, M. A. MASON, read a report summarizing the work of the Committee during the past year. Report will be published in the Proceedings of the Annual Meeting.

The Special Committee on Joint Secretariat, consisting of HARVEY L. CURTIS, chairman, H. S. RAPPLEYE, and NORMAN BEKKEDAHL, submitted the following report:

The following is a report to the Board of Managers of the Washington Academy of Sciences of a special committee appointed in March 1950 to examine the desirability of establishing a central secretarial office to be used jointly by the various scientific societies affiliated with the Academy. This committee [has] sent a circular letter to all the affiliated societies on May 25, 1950, and a follow-up letter on November 20. Replies have been received from all but three of the societies. Six societies stated categorically that they were not interested. Eight societies have sent rather evasive replies. Not one of them indicated anything more than lukewarm interest in the matter. One society suggests that the Academy handle the meeting notices of all societies by means of a monthly publication. Another society indicates that the Engi-

neers' Club has a project similar to that suggested by the Academy and that they are awaiting more complete information from that group before giving a definite reply.

As a result of the information summarized above, this committee does not feel that the Academy would be justified at the present time in establishing a central secretarial office for the scientific societies of Washington.

In discussions concerning the central secretariat the question arose concerning the desirability of having an executive secretary to handle many of the affairs of the Academy now entrusted to the elected secretary and treasurer of the Academy. It may be possible to have office space in the new building of the Cosmos Club and to have a retired member of the Academy serve as executive secretary on a part time basis. This question, however, is considered outside the field of this special committee and no recommendations concerning it are intended. A summary of the activities of the committee is attached hereto.

The Board expressed their gratitude for the work of the committee in completing its assignment.

The following members, having retired from the gainful practice of their professions, were placed on the retired list: ALICE C. EVANS, LLOYD D. FELTON, MAURICE I. SMITH, JOSEPH S. WADE.

The Secretary reported the following deaths: EDWARD A. BIRGE, University of Wisconsin, Madison, Wis., on June 9, 1950 (elected May 15, 1906); CHESTER STOCK, California Institute of Technology, Pasadena, Calif., on December 6, 1950 (elected February 6, 1942); JOHN F. EMBREE, Yale University, New Haven, Conn., on December 22, 1950 (elected June 28, 1943); H. E. EWING, formerly of the U. S. Bureau of Entomology and Plant Quarantine, on January 5, 1951 (elected May 15, 1934).

The Secretary read a report by W. N. FENTON, Chairman of the Committee on the 40-Year Index of the JOURNAL, indicating that the index had now been completed and the cards are marked for the printer.

The Treasurer, HOWARD S. RAPPLEYE, outlined the financial transactions for the year and submitted the report of the Auditing Committee. Details of this report will be printed as part of the Proceedings of the Annual Meeting.

The President expressed his thanks to the Board and to the various committees for their active cooperation during the year.

The meeting was then adjourned at 9:30 P.M. to partake of some refreshments offered by the outgoing President.

F. M. SETZLER, *Secretary*.

## Officers of the Washington Academy of Sciences

*President*.....NATHAN R. SMITH, Plant Industry Station  
*President-elect*.....WALTER RAMBERG, National Bureau of Standards  
*Secretary*.....F. M. DEFANDORF, National Bureau of Standards  
*Treasurer*.....HOWARD S. RAPPLEYE, U. S. Coast and Geodetic Survey  
*Archivist*.....JOHN A. STEVENSON, Plant Industry Station  
*Custodian and Subscription Manager of Publications*  
 HARALD A. REEDER, U. S. National Museum

### *Vice-presidents Representing the Affiliated Societies:*

Philosophical Society of Washington.....EDWARD U. CONDON  
 Anthropological Society of Washington.....WALDO R. WEDEL  
 Biological Society of Washington.....  
 Chemical Society of Washington.....JOSEPH J. FAHEY  
 Entomological Society of Washington.....FREDERICK W. POOS  
 National Geographic Society.....ALEXANDER WETMORE  
 Geological Society of Washington.....LEASON H. ADAMS  
 Medical Society of the District of Columbia.....  
 Columbia Historical Society.....GILBERT GROSVENOR  
 Botanical Society of Washington.....E. H. WALKER  
 Washington Section, Society of American Foresters.....WILLIAM A. DAYTON  
 Washington Society of Engineers.....CLIFFORD A. BETTS  
 Washington Section, American Institute of Electrical Engineers

FRANCIS M. DEFANDORF

Washington Section, American Society of Mechanical Engineers..RICHARD S. DILL  
 Helminthological Society of Washington.....L. A. SPINDLER  
 Washington Branch, Society of American Bacteriologists.....ANGUS M. GRIFFIN  
 Washington Post, Society of American Military Engineers.....HENRY W. HEMPLE  
 Washington Section, Institute of Radio Engineers.....HERBERT G. DORSEY  
 District of Columbia Section, American Society of Civil Engineers....

### *Elected Members of the Board of Managers:*

To January 1952.....W. F. FOSHAG, C. L. GAZIN  
 To January 1953.....C. F. W. MUESEBECK\*, A. T. MCPHERSON  
 To January 1954.....SARA E. BRANHAM, MILTON HARRIS\*

*Board of Managers*.....All the above officers plus the Senior Editor  
*Board of Editors and Associate Editors*.....[See front cover]

*Executive Committee*.....N. R. SMITH (chairman), WALTER RAMBERG, H. S. RAPPLEYE,  
 J. A. STEVENSON, F. M. DEFANDORF

*Committee on Membership*.....L. A. SPINDLER (chairman), M. S. ANDERSON,  
 MERRILL BERNARD, R. E. BLACKWELDER, R. C. DUNCAN, G. T. FAUST, I. B. HANSEN,  
 D. B. JONES, DOROTHY NICKERSON, F. A. SMITH, HEINZ SPECHT, ALFRED WEISSLER

*Committee on Meetings*.....MARGARET PITTMAN (chairman), NORMAN BEKKEDAHLL,  
 W. R. CHAPLINE, D. J. DAVIS, F. B. SCHEETZ, H. W. WELLS

### *Committee on Monographs:*

To January 1952.....J. R. SWALLEN (chairman), PAUL H. OEHSEER  
 To January 1953.....R. W. IMLAY, P. W. OMAN  
 To January 1954.....S. F. BLAKE, F. C. KRACEK

*Committee on Awards for Scientific Achievement* (GEORGE P. WALTON, general chairman):

For the Biological Sciences.....G. H. COONS (chairman), J. E. FABER, JR.,  
 MYRNA F. JONES, F. W. POOS, J. R. SWALLEN

For the Engineering Sciences.....R. S. DILL (chairman), ARSHAM AMIRIKIAN,  
 J. W. MCBURNEY, FRANK NEUMANN, A. H. SCOTT

For the Physical Sciences.....G. P. WALTON (chairman), F. S. BRACKETT,  
 G. E. HOLM, C. J. HUMPHREYS, J. H. McMILLEN

For Teaching of Science.....B. D. VAN EVERA (chairman), R. P. BARNES,  
 F. E. FOX, T. KOPPANYI, M. H. MARTIN, A. T. MCPHERSON

*Committee on Grants-in-aid for Research*.....L. E. YOCUM (chairman),  
 M. X. SULLIVAN, H. L. WHITTEMORE

### *Committee on Policy and Planning:*

To January 1952.....J. I. HOFFMAN (chairman), M. A. MASON  
 To January 1953.....W. A. DAYTON, N. R. SMITH  
 To January 1954.....H. B. COLLINS, JR., W. W. RUBEY

### *Committee on Encouragement of Science Talent:*

To January 1952.....M. A. MASON (chairman), A. T. MCPHERSON  
 To January 1953.....A. H. CLARK, F. L. MOHLER  
 To January 1954.....J. M. CALDWELL, W. L. SCHMITT

*Representative on Council of A. A. A. S.*.....F. M. SETZLER

*Committee of Auditors*.....J. H. MARTIN (chairman), N. F. BRAATEN, W. J. YOUDEN

*Committee of Tellers*.....W. G. BROMBACHER (chairman), A. R. MERZ, LOUISE M. RUSSELL

\* Appointed by Board to fill vacancy.

## CONTENTS

	Page
ARCHEOLOGY.—Additional data on the Denbigh Flint Complex in northern Alaska. RALPH S. SOLECKI and ROBERT J. HACKMAN . . . . .	85
ENTOMOLOGY.— <i>Dinoponera gigantea</i> (Perty), a vicious stinging ant. H. A. ALLARD . . . . .	88
ZOOLOGY.—A revision of the nomenclature of the Gorgoniidae (Coelenterata: Octocorallia), with an illustrated key to the genera. FREDERICK M. BAYER . . . . .	91
MALACOLOGY.—Recent species of the veneroid pelecypod <i>Arctica</i> . DAVID NICOL . . . . .	102
ICHTHYOLOGY.— <i>Chromis atripectoralis</i> , a new damselfish from the tropical Pacific, closely related to <i>C. caeruleus</i> , family Pomacentridae. ARTHUR D. WELANDER and LEONARD P. SCHULTZ . . . . .	107
ICHTHYOLOGY.—A new genus and species of anacanthobatid skate from the Gulf of Mexico. HENRY B. BIGELOW and WILLIAM C. SCHROEDER . . . . .	110
ORNITHOLOGY.—Race names in the Central American jay, <i>Cyanolyca argentigula</i> . FRANK A. PITELKA . . . . .	113
PROCEEDINGS: THE ACADEMY . . . . .	115



# JOURNAL

OF THE

# WASHINGTON ACADEMY OF SCIENCES

## BOARD OF EDITORS

CHARLES DRECHSLER  
PLANT INDUSTRY STATION  
BELTSVILLE, MD.

WILLIAM F. FOSHAG  
U. S. NATIONAL MUSEUM

J. P. E. MORRISON  
U. S. NATIONAL MUSEUM

## ASSOCIATE EDITORS

J. C. EWERS  
ANTHROPOLOGY

C. W. SABROSKY  
ENTOMOLOGY

F. A. CHACE, JR.  
BIOLOGY

J. I. HOFFMAN  
CHEMISTRY

T. P. THAYER  
GEOLOGY

MIRIAM L. BOMHARD  
BOTANY

R. K. COOK  
PHYSICS AND MATHEMATICS

PUBLISHED MONTHLY

BY THE

WASHINGTON ACADEMY OF SCIENCES  
MOUNT ROYAL & GUILFORD AVES.  
BALTIMORE, MARYLAND

Entered as second class matter under the Act of August 24, 1912, at Baltimore, Md.  
Acceptance for mailing at a special rate of postage provided for in the Act of February 28, 1925.  
Authorized February 17, 1949

## Journal of the Washington Academy of Sciences

This JOURNAL, the official organ of the Washington Academy of Sciences, publishes: (1) Short original papers, written or communicated by members of the Academy; (2) proceedings and programs of meetings of the Academy and affiliated societies; (3) notes of events connected with the scientific life of Washington. The JOURNAL is issued monthly. Volumes correspond to calendar years.

*Manuscripts* may be sent to any member of the Board of Editors. It is urgently requested that contributors consult the latest numbers of the JOURNAL and conform their manuscripts to the usage found there as regards arrangement of title, subheads, synonyms, footnotes, tables, bibliography, legends for illustrations, and other matter. Manuscripts should be typewritten, double-spaced, on good paper. Footnotes should be numbered serially in pencil and submitted on a separate sheet. The editors do not assume responsibility for the ideas expressed by the author, nor can they undertake to correct other than obvious minor errors.

*Illustrations in excess* of the equivalent (in cost) of one full-page halftone are to be paid for by the author.

*Proof.*—In order to facilitate prompt publication one proof will generally be sent to authors in or near Washington. It is urged that manuscript be submitted in final form; the editors will exercise due care in seeing that copy is followed.

*Unusual cost* of foreign, mathematical, and tabular material, as well as alterations made in the proof by the author, may be charged to the author.

*Author's Reprints.*—Reprints will be furnished in accordance with the following schedule of prices (approximate):

Copies	4 pp.	8 pp.	12 pp.	16 pp.	20 pp.	Covers
100	\$3.25	\$6.50	\$ 9.75	\$13.00	\$16.25	\$3.00
200	6.50	13.00	19.50	26.00	32.50	6.00
300	9.75	19.50	29.25	39.00	48.75	9.00
400	13.00	26.00	39.00	52.00	65.00	12.00

*Subscriptions* or requests for the purchase of back numbers or volumes of the JOURNAL or the PROCEEDINGS should be sent to HARALD A. REHDER, Custodian and Subscription Manager of Publications, U. S. National Museum, Washington 25, D. C.

*Subscription Rates for the JOURNAL.*—Per year..... \$7.50

Price of back numbers and volumes:	Per Vol.	Per Number
Vol. 1 to vol. 10, incl.—not available.*	—	—
Vol. 11 to vol. 15, incl. (21 numbers per vol.)	\$10.00	\$0.70
Vol. 16 to vol. 22, incl. (21 numbers per vol.)	8.00	0.60
Vol. 23 to current vol. (12 numbers per vol.)	7.50	0.90

\* Limited number of complete sets of the JOURNAL (vol. 1 to vol. 40, incl.) available for sale to libraries at \$341.00

MONOGRAPH No. 1, "The Parasitic Cuckoos of Africa," by Herbert Friedmann.	\$4.50
PROCEEDINGS, vols. 1-13 (1899-1911) complete.	\$25.00
Single volumes, unbound.	2.00
Single numbers.	.25

*Missing Numbers* will be replaced without charge provided that claim is made to the Treasurer within 30 days after date of following issue.

*Remittances* should be made payable to "Washington Academy of Sciences" and addressed to the Treasurer, H. S. RAPPLEYE, 6712 Fourth Street, N.W., Washington 12, D. C.

*Exchanges.*—The Academy does not exchange its publications for those of other societies.

# JOURNAL OF THE WASHINGTON ACADEMY OF SCIENCES

VOLUME 41

April 1951

No. 4

MATHEMATICS.—*The theory of group representations.*<sup>1</sup> FRANCIS E. JOHNSTON,  
George Washington University.

The modern theory of groups began with what are called permutation groups in the attempts of Lagrange, Ruffini, Vandermonde, and Galois to solve the general algebraic equation of degree greater than 4. Today we usually define a group abstractly by a set of postulates. Suppose we have a finite or infinite set of distinct elements  $s, t, u, \dots$  and a rule of combination of these elements such that two of them may combine to produce a unique element of the set, or such that an element may combine with itself to produce a unique element of the set. We shall call this process of combining "multiplication" and shall write the two combining elements in juxtaposition as is done in ordinary algebraic multiplication; the result of their combination we shall call their "product". We assume the following four postulates satisfied (the first of which has already been included in the above description):

1. The product  $ts$  is a unique element  $u$  of the set  $u = ts$ .
2. The associative law holds:  $u(ts) = (ut)s$ .
3. There exists in the set an element  $e$  such  $se = s$  for all  $s$  of the set. ( $e$  is the right identity.)
4. To every element  $s$  of the set there corresponds an elements denoted by  $s^{-1}$  such that  $ss^{-1} = e$ . ( $s^{-1}$  is the right inverse of  $s$  with regard to  $e$ .)

Such a set of elements is said to constitute a group. It can be shown that the assumed right identity is unique and that it is also a unique left identity. It can be shown also that the right inverse of an element is unique and is also a unique left inverse for that element, so that we have  $se = es = s$  and  $s^{-1}s = ss^{-1} = e$ .

If it happens that  $st = ts$  the group is

<sup>1</sup> Address of the retiring president of the Philosophical Society of Washington, January 14, 1950.

said to be abelian. We may define the integral powers of an element:  $s^2 = s \cdot s$ , and by induction  $s^n = s \cdot s^{n-1}$ . Also  $s^{-n} = (s^{-1})^n$  and  $s^0 = e$ . All the elementary algebraic laws of exponents immediately follow.

If the number of elements in the group is finite the group is a finite group, otherwise infinite. For a finite group the number of elements is the order of the group. Evidently the powers of a single element constitute a group, called a cyclic group. If this group is finite, that is, if  $s^n = e$  and  $s^m \neq e$ , where  $m$  is less than  $n$ , then  $n$  is said to be the order of the element  $s$ . A cyclic group of infinite order is said to be a free group.

Elementary examples of groups are numerous. If the rule of combination is ordinary arithmetic multiplication, then the set of all positive rational numbers is a group, in which one is the identity and the inverse of  $\frac{p}{q}$  is  $\frac{q}{p}$ . If the rule of combination is ordinary algebraic multiplication then the four numbers  $1, -1, i, -i$  ( $i^2 = -1$ ) constitute a cyclic group of order 4, since the elements are the powers of  $i$ .

Sets of nonsingular square matrices constitute groups, the elements of the matrices being numbers of the complex number field and the rule of combination being ordinary matrix multiplication. That is, if

$$A = \begin{pmatrix} a_{11} & a_{12} & a_{13} & \cdots & a_{1n} \\ \cdots & \cdots & \cdots & \cdots & \cdots \\ a_{n1} & a_{n2} & a_{n3} & \cdots & a_{nn} \end{pmatrix} \text{ and } B = \begin{pmatrix} b_{11} & b_{12} & b_{13} & \cdots & b_{1n} \\ \cdots & \cdots & \cdots & \cdots & \cdots \\ b_{n1} & b_{n2} & b_{n3} & \cdots & b_{nn} \end{pmatrix}$$

$$C = \begin{pmatrix} c_{11} & c_{12} & c_{13} & \cdots & c_{1n} \\ \cdots & \cdots & \cdots & \cdots & \cdots \\ c_{n1} & c_{n2} & c_{n3} & \cdots & c_{nn} \end{pmatrix} \text{ and } AB = C$$

$$\text{then } c_{ij} = \sum_{k=1}^n a_{ik} b_{kj} \quad \text{where} \quad \begin{matrix} i = 1, 2, \dots, n \\ j = 1, 2, \dots, n \end{matrix}$$

The identity matrix for a group of matrices each with  $n$  rows is the matrix

$$\begin{pmatrix} 1 & 0 & \dots & 0 \\ 0 & 1 & \dots & 0 \\ \dots & \dots & \dots & \dots \\ 0 & 0 & \dots & 1 \end{pmatrix}$$

and methods of computing the inverse of a nonsingular matrix are well known. The three groups below are simple examples of groups of matrices. The first set of six matrices constitutes a group of order six. Beneath each matrix I have written a letter which may serve to designate the element, since the same group is used as an illustration later.  $E$  is the identity element;  $A$ ,  $B$  and  $C$  are of order two, while  $D$  and  $F$  are of order three. The second set of six matrices likewise constitute a group of order six,  $\omega$  representing a complex cube root of unity. The same letters as before may be associated with these elements for later identification,  $E$  again being the identity,  $A$ ,  $B$ , and  $C$  of order 2, and  $D$  and  $F$  of order 3. The third set of matrices constitute a group of order 8.

$$\begin{matrix} \begin{pmatrix} 1 & 0 \\ 0 & 1 \end{pmatrix}, & \begin{pmatrix} 1 & 0 \\ 0 & -1 \end{pmatrix}, \\ E & A \\ \begin{pmatrix} -\frac{1}{2} & \frac{1}{2}\sqrt{3} \\ \frac{1}{2}\sqrt{3} & \frac{1}{2} \end{pmatrix}, & \begin{pmatrix} -\frac{1}{2} & -\frac{1}{2}\sqrt{3} \\ -\frac{1}{2}\sqrt{3} & \frac{1}{2} \end{pmatrix}, \\ B & C \\ \begin{pmatrix} -\frac{1}{2} & \frac{1}{2}\sqrt{3} \\ -\frac{1}{2}\sqrt{3} & -\frac{1}{2} \end{pmatrix}, & \begin{pmatrix} -\frac{1}{2} & -\frac{1}{2}\sqrt{3} \\ \frac{1}{2}\sqrt{3} & -\frac{1}{2} \end{pmatrix}, \\ D & F \\ \begin{pmatrix} 1 & 0 \\ 0 & 1 \end{pmatrix}, & \begin{pmatrix} 0 & 1 \\ 1 & 0 \end{pmatrix}, & \begin{pmatrix} 0 & \omega \\ \omega^2 & 0 \end{pmatrix}, \\ \begin{pmatrix} 0 & \omega^2 \\ \omega & 0 \end{pmatrix}, & \begin{pmatrix} \omega & 0 \\ 0 & \omega^2 \end{pmatrix}, & \begin{pmatrix} \omega^2 & 0 \\ 0 & \omega \end{pmatrix}; \end{matrix}$$

where  $\omega^2 + \omega + 1 = 0$

$$\begin{matrix} \begin{pmatrix} 1 & 0 \\ 0 & 1 \end{pmatrix}, & \begin{pmatrix} 0 & 1 \\ -1 & 0 \end{pmatrix}, & \begin{pmatrix} -1 & 0 \\ 0 & -1 \end{pmatrix}, & \begin{pmatrix} 0 & -1 \\ 1 & 0 \end{pmatrix}, \\ \begin{pmatrix} 1 & 0 \\ 0 & -1 \end{pmatrix}, & \begin{pmatrix} 0 & 1 \\ 1 & 0 \end{pmatrix}, & \begin{pmatrix} -1 & 0 \\ 0 & 1 \end{pmatrix}, & \begin{pmatrix} 0 & -1 \\ -1 & 0 \end{pmatrix}. \end{matrix}$$

Matrices of course arose from "linear transformations" and the groups of matrices are really the groups of the linear transformations which give rise to these matrices. In a mathematical system involving certain

variables,  $x_1, x_2, \dots, x_n$ , it may be convenient to replace these variables by new variables,  $x'_1, x'_2, \dots, x'_n$ , through the medium of a linear transformation:

$$\begin{matrix} x'_1 = a_{11}x_1 + \dots + a_{1n}x_n \\ x'_2 = a_{21}x_1 + \dots + a_{2n}x_n \\ \dots \\ x'_n = a_{n1}x_1 + \dots + a_{nn}x_n \end{matrix} \quad A$$

A second linear transformation may replace the  $x'_1, x'_2, \dots, x'_n$  by  $x''_1, x''_2, \dots, x''_n$ :

$$\begin{matrix} x''_1 = b_{11}x'_1 + \dots + b_{1n}x'_n \\ x''_2 = b_{21}x'_1 + \dots + b_{2n}x'_n \\ \dots \\ x''_n = b_{n1}x'_1 + \dots + b_{nn}x'_n \end{matrix} \quad B$$

By the "product" of two such linear transformations we mean simply their sequential performance and the result of first operating on the system by the transformation  $A$  and then by the transformation  $B$  will be the same as if we operated by the single transformation  $C$ , where  $C = BA$ , which replaces the original variables directly by  $x''_1, x''_2, \dots, x''_n$ . In practice, however, we generally use just the unaccented variables on the right in a given transformation and simple accented ones on the left, imagining the process to start anew each time.

I said that group theory began with permutation groups in the attempt of mathematicians to solve algebraic equations of higher degree. If we have a set of letters or symbols which appear in a mathematical system, and each of them is replaced by a distinct one of the set then we effect a "permutation" on the letters. This process may be denoted by writing them in any convenient order on one line (the "natural" order if they seem to possess one) and then writing below each letter the one by which it is replaced. Usually large parentheses are used to enclose the array. Thus if the symbols are the letters  $a, b, c, d$ , four such permutations are the following:

$$\begin{matrix} (a & b & c & d) \\ (a & b & c & d) \\ (a & b & c & d) \\ (a & b & c & d) \end{matrix}, \begin{matrix} (a & b & c & d) \\ (b & c & d & a) \\ (c & d & a & b) \\ (d & a & b & c) \end{matrix}.$$

The first of these represents the identity permutation wherein each letter remains unchanged; in the second permutation  $a$  is replaced by  $b$ ,  $b$  by  $c$ ,  $c$  by  $d$ , and  $d$  by  $a$ ; in the third  $a$  is replaced by  $c$ ,  $b$  by  $d$ ,  $c$  by  $a$ ,

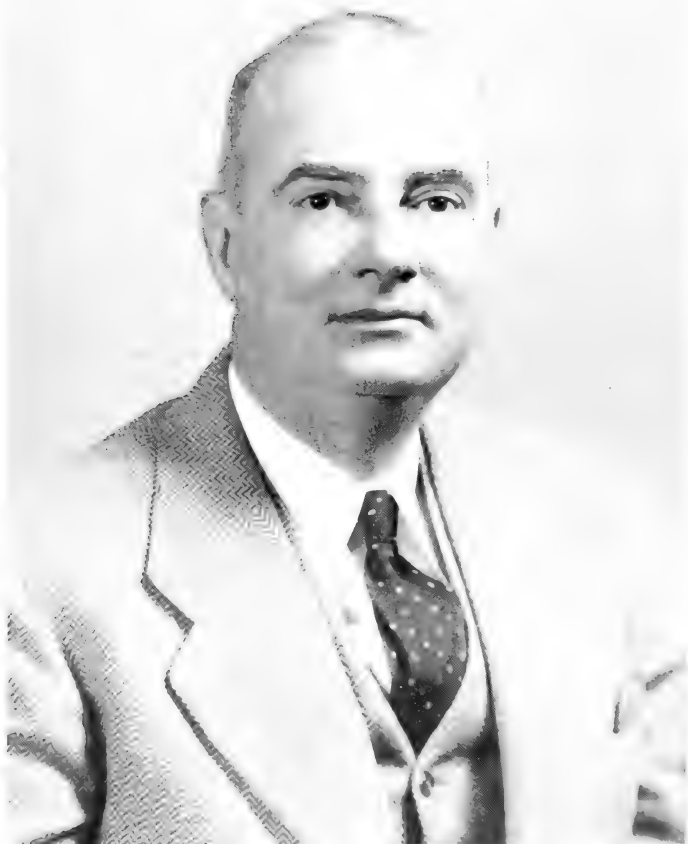

FRANCIS E. JOHNSTON, President of the Philosophical Society of Washington, 1949.



and  $d$  by  $b$ ; in the last  $a$  is replaced by  $d$ ,  $b$  by  $a$ ,  $c$  by  $b$ , and  $d$  by  $c$ . The product of two permutations is their sequential performance; thus the product of the second of the above permutations followed by the third is the last. It is not difficult to verify the fact that the above four permutations satisfy the requirements for a group and hence constitute a permutation group.

Sometimes it is convenient to represent a permutation by a sequence of letters in which each letter is replaced by the letter to its right, the rightmost letter in the "cycle" being replaced by the letter at the beginning of the cycle. If when the cycle is thus "closed" all letters have not been accounted for, a new cycle is begun, and so on until all letters have been taken care of. In this scheme, letters which are replaced by themselves constitute cycles of a single letter and when there is no danger of confusion such cycles are frequently omitted. When a permutation is written in its simplest form as a product of cycles no two cycles will have a common letter, and hence they will be commutative and may be written in any order. Thus

$$\begin{pmatrix} a & b & c & d & e \\ b & e & d & c & a \end{pmatrix} = abe \cdot cd = bea \cdot cd = bea \cdot dc = dc \cdot bea$$

Indeed there are 12 ways to represent the above permutation in the manner under discussion.

Denote by  $\alpha_1$  the number of unary cycles, by  $\alpha_2$  the number of cycles with two letters each, by  $\alpha_3$  the number of cycles with three letters each, etc. Then

$$\alpha_1 + 2\alpha_2 + 3\alpha_3 + \dots + n\alpha_n = n$$

Such a permutation is said to belong to the "class"  $(\alpha_1, \alpha_2, \dots, \alpha_n)$ .

When a permutation on  $n$  letters is written in the 2-row form the letters of the top row may be written in an arbitrary order and those of the lower row may then be written in any one of  $n!$  orders; hence there are  $n!$  permutations on  $n$  letters and the aggregate will constitute a group, the "symmetric" group on  $n$  letters. It is not difficult to see (as brought out in the next paragraph) that the number of classes of elements in the symmetric group equals the number of partitions of  $n$  with regard to addition into non-negative summands. This is a very old prob-

lem in number theory and we tabulate the number of partitions for some values of  $n$ :

Value of $n$	Number of partitions of $n$
1	1
2	2
3	3
4	5
5	7
6	11
7	15
8	22
9	30
10	42
16	231
20	627
....	....
200	3,972,999,029,388.

For example, the partitions of 5 are  $5, 4 + 1, 3 + 2, 3 + 1 + 1, 2 + 2 + 1, 2 + 1 + 1 + 1, 1 + 1 + 1 + 1 + 1$ , a total of seven.

If we write

$$\begin{aligned} \alpha_1 + \alpha_2 + \dots + \alpha_n &= \lambda_1 \\ \alpha_2 + \dots + \alpha_n &= \lambda_2 \\ \dots & \dots \\ \alpha_n &= \lambda_n \end{aligned}$$

then

$$\lambda_1 + \lambda_2 + \dots + \lambda_n = n\lambda_1 \geq \lambda_2 \geq \lambda_3 \geq \dots \geq \lambda_n \geq 0$$

and

$$\begin{aligned} \alpha_1 &= \lambda_1 - \lambda_2, & \alpha_2 &= \lambda_2 - \lambda_3, \dots, \\ \alpha_{n-1} &= \lambda_{n-1} - \lambda_n, & \alpha_n &= \lambda_n \end{aligned}$$

A partition of  $n$  will thus be in the form  $(\lambda_1, \lambda_2, \lambda_3, \dots, \lambda_n)$ . For example if  $n$  is 10 we have the partition  $(3, 2, 2, 1, 1, 1, 0, 0, 0, 0) = (3, 2, 2, 1, 1, 1) = (3, 2^2, 1^3)$ . We have omitted unnecessary zeros at the end and also have used exponents to avoid duplication. Here

$$\begin{aligned} \alpha_1 &= 3 - 2 = 1, & \alpha_2 &= 2 - 2 = 0, \\ \alpha_3 &= 2 - 1 = 1, & \alpha_4 &= 1 - 1 = 0 \\ \alpha_5 &= 1 - 1 = 0, & \alpha_6 &= 1 - 0 = 1, \\ \alpha_7 &= \alpha_8 = \alpha_9 = \alpha_{10} = 0. \end{aligned}$$

Hence the above partition corresponds to a class of elements having the structure: one unary cycle, one ternary cycle, one cycle of six letters. For  $n = 3$  and  $n = 4$  we list the partitions, the number of elements in the corresponding class, and the actual permutations:

Partition	Class			Number of permutations	List of permutations
$n = 3$ (1, 1, 1) (2, 1) (3)	$\alpha_1 = 0,$	$\alpha_2 = 0$	$\alpha_3 = 1$	2	$abc, acb$
	$\alpha_1 = 1,$	$\alpha_2 = 1$		3	$ab, ac, bc$
	$\alpha_1 = 3$			1	identity
$n = 4$ (1, 1, 1, 1) (3, 1) (2, 2) (2, 1, 1) (4)	$\alpha_1 = \alpha_2 = \alpha_3 = 0,$		$\alpha_4 = 1$	6	$abcd, acdb, abdc, acdb$
	$\alpha_1 = 2,$	$\alpha_2 = 1$		6	$ab, ac, ad, bc, bd, cd$
	$\alpha_1 = 0,$	$\alpha_2 = 2$		3	$ab \cdot cd, ac \cdot bd, ad \cdot bc$
	$\alpha_1 = 1,$	$\alpha_2 = 0,$	$\alpha_3 = 1$	8	$abc, acb, abd, abb$
	$\alpha_1 = 4$			1	$acd, adc, bcd, bdc.$ identity

Without stopping to advance an argument we note that the number of permutations on  $n$  letters in the class  $(\alpha_1, \alpha_2, \alpha_3, \dots)$  is given by

$$\frac{n!}{(1^{\alpha_1} \cdot \alpha_1!)(2^{\alpha_2} \cdot \alpha_2!)(3^{\alpha_3} \cdot \alpha_3!) \dots}$$

where as usual  $0! = 1$ . This formula is verifiable in the simple cases above.

A permutation group may be interpreted as a group of matrices. Thus, if we write the permutation in the 2-row form and accent the symbols in the lower row we have a transformation, which is given by its matrix. For example, on three letters the per-

$$\text{mutation} \begin{pmatrix} x_1 & x_2 & x_3 \\ x_2' & x_3' & x_1' \end{pmatrix}$$

is essentially the transformation

$$\begin{aligned} x_1' &= x_3 \\ x_2' &= x_1 \\ x_3' &= x_2 \end{aligned}$$

with the matrix  $\begin{pmatrix} 0 & 0 & 1 \\ 1 & 0 & 0 \\ 0 & 1 & 0 \end{pmatrix}$ . It will be observed

that matrices corresponding to permutations have in each row every element zero except one element, which has the value 1, and likewise in each column they have every element zero except one element which has the value 1.

If  $A_1 = E$  (the identity element),  $A_2, A_3, \dots, A_\sigma$  constitute a finite group of matrices and  $M$  is a matrix, then the set of matrices  $MA_1M^{-1}, MA_2M^{-1}, MA_3M^{-1}, \dots,$

$MA_\sigma M^{-1}$  likewise constitute a group; a group which is simply isomorphic with the original group. This means that if  $A_i A_j = A_k$  then  $(MA_i M^{-1})(MA_j M^{-1}) = MA_k M^{-1}$ . The second group is said to be conjugate with the first and is said to be obtained from it by transforming the first group by  $M$ . It may happen that the second group will be identical with the first group, perhaps because the individual matrices of the group are unchanged when transformed by  $M$ , or because the set of matrices as a whole is identical except for order after it is transformed by  $M$ . When this is the case the group is said to be invariant under  $M$ .

A matrix  $\bar{M}$  is obtained from the matrix  $M$  by replacing each of the elements by its conjugate number is the conjugate of  $M$ . In symbols

$$\bar{M} = (\bar{a}_{ij})$$

A matrix obtained from  $M$  by interchanging the roles of the rows and columns of  $M$  is called the transposed of  $M$  and is denoted by  $M'$ . That is,

$$M' = (a'_{ij}) \quad \text{where} \quad a'_{ij} = a_{ji}$$

A matrix is said to be Hermitian if it equals the transposed of the conjugate of itself, that is  $H$  is a Hermitian matrix if

$$H = \bar{H}' \quad \text{or} \quad \bar{a}_{ij} = a_{ji}$$

A matrix is said to be unitary if it equals the inverse of the transposed of the conjugate of itself, that is  $U$  is unitary if  $U = (\bar{U}')^{-1}$ . It follows at once that the necessary and sufficient condition that a matrix be unitary is that the relations hold:



$$\sum_{k=1}^{k=n} a_{ki} \bar{a}_{kj} = \delta_{ij}$$

$$i = 1, \dots, n$$

$$j = 1, \dots, n$$

$$\delta_{ij} = \begin{cases} 1 & \text{if } i = j \\ 0 & \text{if } i \neq j \end{cases}$$

This condition may also be expressed in the equivalent form

$$\sum_{k=1}^{k=n} a_{ik} \bar{a}_{jk} = \delta_{ij}$$

A matrix is said to be *orthogonal* if it equals the inverse of the transposed of itself, that is 0 is orthogonal if

$$0 = (0')^{-1}$$

Evidently for a real matrix the terms orthogonal and unitary mean the same thing.

Suppose we have a group  $G$  consisting of the elements  $A_1, A_2, \dots$  and to each element  $A_i$  of  $G$  we make correspond a non-singular matrix  $D(A_i)$  such that if  $D(A_i)$  corresponds to  $A_i$  and  $D(A_j)$  corresponds to  $A_j$  then  $D(A_j A_i)$  corresponds to  $A_j A_i$ . Then the set of matrices is said to be a *representation of  $G$* . We have not said that distinct matrices must correspond to distinct group elements; if that is the case the representation is said to be a *faithful representation* and the matrices will themselves form a group, a group simply isomorphic with the given group. It is evident that we shall always have a representation in which every group element corresponds to the identity matrix with one row, that is, every element corresponds to the matrix (1). Equally well we might make every element correspond to the identity matrix with two or three or more rows.

Now it may happen that we can find a matrix  $M$  such that if we transform simultaneously all the matrices of a representation by it they will all take the form

$$\begin{bmatrix} D^{(1)}(A_i) & 0 & \dots & 0 \\ 0 & D^{(2)}(A_i) & \dots & 0 \\ \dots & \dots & \dots & \dots \\ 0 & 0 & \dots & D^{(k)}(A_i) \end{bmatrix}$$

If this is true, the original representation is said to be reducible and it has the constit-

uents  $D^{(1)}(A_i), D^{(2)}(A_i), \dots$ . Each of these constituents (not necessarily assumed to be all distinct) is also a representation of the given group. If a constituent is such that it cannot be further reduced then it is said to be an irreducible representation; and we assume the transforming matrix so chosen that each  $D(A_i)$  is irreducible. Then if the original representation of the group  $G$  under discussion is denoted by  $\Gamma$ ,  $\Gamma$  is said to be expressed in terms of its irreducible constituents and we write

$$\Gamma(A_i) = D^{(1)}(A_i) \dot{+} D^{(2)}(A_i) \dot{+} \dots \dot{+} D^{(k)}(A_i).$$

A matrix of  $\Gamma$  is thus the *direct sum* of matrices, one from each of the irreducible representations. Note that this is a different concept from the sum of two matrices. The direct sum means that they are strung out down the main diagonal with zeros elsewhere.

If we have a group  $s, t, u, \dots$  and if we transform an element by one of the group elements we obtain the transform or conjugate, thus  $tst^{-1}$  is the transform of  $s$  by  $t$ . If  $s$  and  $t$  are commutative, that is if  $st = ts$ , then  $tst^{-1} = s$  and  $s$  is said to be invariant under  $t$ . In any group an element and all the elements into which it may be transformed by all the elements of the group constitute a *class* of elements. In an abelian group each element is invariant and constitutes a class by itself; hence if the group is finite the number of classes is the order of the group. In the symmetric permutation group all elements with the same cyclic structure are in the same class as noted above. In a non-symmetric group elements with the same cyclic structure may not be all in the same class.

It is a fact that the number of non-equivalent irreducible representations of any finite group equals the number of its classes. Thus the symmetric group on three letters has three classes and three irreducible representations. We show this in the table below:

$$\begin{matrix} 1 & (1) & (1) & \begin{pmatrix} 1 & 0 \\ 0 & 1 \end{pmatrix} & E \\ acb & (1) & (1) & \begin{pmatrix} \omega & 0 \\ 0 & \omega^2 \end{pmatrix} & D \end{matrix}$$

$$\begin{array}{lll}
 abc & (1) & (1) \begin{pmatrix} \omega^2 & 0 \\ 0 & \omega \end{pmatrix} & F \\
 ab & (1) & (-1) \begin{pmatrix} 0 & 1 \\ 1 & 0 \end{pmatrix} & A \\
 bc & (1) & (-1) \begin{pmatrix} 0 & \omega \\ \omega^2 & 0 \end{pmatrix} & B \\
 ac & (1) & (-1) \begin{pmatrix} 0 & \omega^2 \\ \omega & 0 \end{pmatrix} & C
 \end{array}$$

The first of these representations is of dimension one and is the representation in which every element corresponds to the identity matrix. The second is of dimension one also and three of the elements correspond to the identity matrix, three to the matrix (-1). The third is of dimension 2 and is a faithful representation

It is a fact that every finite group may be made simply isomorphic to a permutation group, indeed in many ways. In particular it may have a faithful representation as a regular permutation group, that is a group in which every letter is replaced by every other letter of the group by one and only one permutation, which means that no permutation (except the identity) leaves any letter invariant. In this procedure the number of letters is the order of the group. Thus the symmetric group on three letters is of order 6, and hence may have a faithful representation as a regular permutation group on six letters. It is also a fact that there always exists a matrix which will transform this representation into the sum of its irreducible constituents and that in this reduced form every irreducible representation will appear and that the number of times it appears is equal to its dimension. We saw above that the symmetric group on three letters (whose order is six) had exactly three irreducible representations, two of dimension one and one of dimension two. In the reduced form the representation of dimension two should therefore appear twice, as is indeed the case. From this we conclude that the sum of the squares of the dimensions of the irreducible representations should equal the order of the group. That is, in the case under con-

sideration:  $1^2 + 1^2 + 2^2 = 6$ . To give the notion a little concrete reality we exhibit the above mentioned symmetric group and the transforming matrix and the reduced form.

As a regular permutation group the group is as follows:  $E = \text{identity}$ ,  $A = x_1x_4 \cdot x_2x_6 \cdot x_3x_5$ ,  $B = x_1x_5 \cdot x_2x_4 \cdot x_3x_6$ ,  $C = x_1x_6 \cdot x_2x_5 \cdot x_3x_4$ ,  $D = x_1x_3x_2 \cdot x_4x_6x_5$ ,  $F = x_1x_2x_3 \cdot x_4x_5x_6$ . Interpreted as a group of linear transformations (whose matrices give the regular representation) we have:

$$\begin{array}{ll}
 E = \text{identity} & A = \begin{Bmatrix} x'_1 = \dots\dots\dots x_4 \dots \\ x'_2 = \dots\dots\dots x_6 \dots \\ x'_3 = \dots\dots\dots x_5 \dots \\ x'_4 = x_1 \dots\dots\dots \\ x'_5 = \dots\dots\dots x_3 \dots\dots\dots \\ x'_6 = \dots\dots\dots x_2 \dots\dots\dots \end{Bmatrix} \\
 B = \begin{Bmatrix} x'_1 = \dots\dots\dots x_5 \dots \\ x'_2 = \dots\dots\dots x_1 \dots\dots\dots \\ x'_3 = \dots\dots\dots x_6 \dots\dots\dots \\ x'_4 = \dots\dots\dots x_2 \dots\dots\dots \\ x'_5 = x_1 \dots\dots\dots \\ x'_6 = \dots\dots\dots x_3 \dots\dots\dots \end{Bmatrix} & C = \begin{Bmatrix} x'_1 = \dots\dots\dots x_6 \dots \\ x'_2 = \dots\dots\dots x_5 \dots\dots\dots \\ x'_3 = \dots\dots\dots x_4 \dots\dots\dots \\ x'_4 = \dots\dots\dots x_3 \dots\dots\dots \\ x'_5 = \dots\dots\dots x_2 \dots\dots\dots \\ x'_6 = x_1 \dots\dots\dots \end{Bmatrix} \\
 D = \begin{Bmatrix} x'_1 = \dots\dots\dots x_2 \dots\dots\dots \\ x'_2 = \dots\dots\dots x_3 \dots\dots\dots \\ x'_3 = x_1 \dots\dots\dots \\ x'_4 = \dots\dots\dots x_5 \dots\dots\dots \\ x'_5 = \dots\dots\dots x_6 \dots\dots\dots \\ x'_6 = \dots\dots\dots x_4 \dots\dots\dots \end{Bmatrix} & F = \begin{Bmatrix} x'_1 = \dots\dots\dots x_3 \dots\dots\dots \\ x'_2 = x_1 \dots\dots\dots \\ x'_3 = \dots\dots\dots x_2 \dots\dots\dots \\ x'_4 = \dots\dots\dots x_6 \dots\dots\dots \\ x'_5 = \dots\dots\dots x_1 \dots\dots\dots \\ x'_6 = \dots\dots\dots x_5 \dots\dots\dots \end{Bmatrix}
 \end{array}$$

The matrix

$$T = \begin{pmatrix} 1 & 1 & 1 & 1 & 1 & 1 \\ 1 & 1 & 1 & -1 & -1 & -1 \\ 1 & \omega & \omega^2 & 0 & 0 & 0 \\ 0 & 0 & 0 & 1 & \omega^2 & \omega \\ 0 & 0 & 0 & 1 & \omega & \omega^2 \\ 1 & \omega^2 & \omega & 0 & 0 & 0 \end{pmatrix}$$

with the inverse

$$T^{-1} = \frac{1}{6} \begin{pmatrix} 1 & 1 & 2 & 0 & 0 & 2 \\ 1 & 1 & 2\omega^2 & 0 & 0 & 2\omega \\ 1 & 1 & 2\omega & 0 & 0 & 2\omega^2 \\ 1 & -1 & 0 & 2 & 2 & 0 \\ 1 & -1 & 0 & 2\omega & 2\omega^2 & 0 \\ 1 & -1 & 0 & 2\omega^2 & 2\omega & 0 \end{pmatrix}$$

will transform the regular representation in this fashion

$$TET^{-1} = E', \quad TAT^{-1} = A', \quad \dots, \quad TFT^{-1} = F'$$

where the matrices for the primed representation are as follows:

$$E' = \begin{pmatrix} 1 & 0 & 0 & 0 & 0 & 0 \\ 0 & 1 & 0 & 0 & 0 & 0 \\ 0 & 0 & 1 & 0 & 0 & 0 \\ 0 & 0 & 0 & 1 & 0 & 0 \\ 0 & 0 & 0 & 0 & 1 & 0 \\ 0 & 0 & 0 & 0 & 0 & 1 \end{pmatrix} \quad A' = \begin{pmatrix} 1 & 0 & 0 & 0 & 0 & 0 \\ 0 & -1 & 0 & 0 & 0 & 0 \\ 0 & 0 & 0 & 1 & 0 & 0 \\ 0 & 0 & 1 & 0 & 0 & 0 \\ 0 & 0 & 0 & 0 & 0 & 1 \\ 0 & 0 & 0 & 0 & 1 & 0 \end{pmatrix}$$

$$\begin{aligned}
 B' &= \begin{pmatrix} 1 & 0 & 0 & 0 & 0 & 0 \\ 0 & -1 & 0 & 0 & 0 & 0 \\ 0 & 0 & 0 & \omega & 0 & 0 \\ 0 & 0 & \omega^2 & 0 & 0 & 0 \\ 0 & 0 & 0 & 0 & 0 & \omega \\ 0 & 0 & 0 & 0 & \omega^2 & 0 \end{pmatrix} & C' &= \begin{pmatrix} 1 & 0 & 0 & 0 & 0 & 0 \\ 0 & -1 & 0 & 0 & 0 & 0 \\ 0 & 0 & 0 & \omega^2 & 0 & 0 \\ 0 & 0 & \omega & 0 & 0 & 0 \\ 0 & 0 & 0 & 0 & 0 & \omega^2 \\ 0 & 0 & 0 & 0 & \omega & 0 \end{pmatrix} \\
 D' &= \begin{pmatrix} 1 & 0 & 0 & 0 & 0 & 0 \\ 0 & 1 & 0 & 0 & 0 & 0 \\ 0 & 0 & \omega & 0 & 0 & 0 \\ 0 & 0 & 0 & \omega^2 & 0 & 0 \\ 0 & 0 & 0 & 0 & \omega & 0 \\ 0 & 0 & 0 & 0 & 0 & \omega^2 \end{pmatrix} & F' &= \begin{pmatrix} 1 & 0 & 0 & 0 & 0 & 0 \\ 0 & 1 & 0 & 0 & 0 & 0 \\ 0 & 0 & \omega^2 & 0 & 0 & 0 \\ 0 & 0 & 0 & \omega & 0 & 0 \\ 0 & 0 & 0 & 0 & \omega^2 & 0 \\ 0 & 0 & 0 & 0 & 0 & \omega \end{pmatrix}
 \end{aligned}$$

each correspond to representations of dimension one so that the Hermitian length in each case would be  $\sqrt{6}$ . We write the six vectors together so that the relation is more clearly discernable.

$$\begin{pmatrix} 1 & 1 & 1 & 1 & 1 & 1 \\ 1 & 1 & 1 & -1 & -1 & -1 \\ 1 & \omega & \omega^2 & 0 & 0 & 0 \\ 0 & 0 & 0 & 1 & \omega & \omega^2 \\ 0 & 0 & 0 & 1 & \omega^2 & \omega \\ 1 & \omega^2 & \omega & 0 & 0 & 0 \end{pmatrix}$$

It is a simple matter to verify this result by a little computation. Indeed it is only necessary to verify it for two of the "generators," say  $A$  and  $B$ .

We note a few simple and interesting facts about the representations of a finite group. In the first place there always exists a matrix which will transform all the matrices of a representation of a finite group into unitary matrices. This is also true of many infinite groups. All the representations we have noted so far have been unitary representations and we shall always assume that our representations are unitary. When two equivalent representations are unitary, the transforming matrix which carries one representation into the other may be chosen to be unitary. For convenience the transforming matrix  $T$  above was not so chosen, but it could have been.

If we have an *irreducible* representation of dimension  $l_1$  of a group of order  $g$  and we construct the  $l_1^2$  vectors in the  $g$ -dimensional space of the group elements, then we have a set of orthogonal unitary vectors (except that the "Hermitian length" of the vectors is  $\sqrt{g/l_1}$ ). Thus for the two dimensional representation of the symmetric group on three letters we have the four vectors  $(1, \omega, \omega^2, 0, 0, 0)$ ,  $(0, 0, 0, 1, \omega, \omega^2)$ ,  $(0, 0, 0, 1, \omega^2, \omega)$ ,  $(1, \omega^2, \omega, 0, 0, 0)$ . If we add to this system  $l_2^2, l_3^2$  etc. vectors corresponding to other non-equivalent irreducible representations in the  $g$ -dimensional space of the group elements we then have a system of  $l_1^2 + l_2^2 + l_3^2 + \dots$  unitary orthogonal vectors, with the same assumptions as to the Hermitian length of the vectors. Thus in the case of the three representations of the symmetric group above we should have to add to the four vectors above the two vectors  $(1, 1, 1, 1, 1, 1)$ , and  $(1, 1, 1, -1, -1, -1)$ . These last two vectors

If  $D(R)$  is the matrix corresponding to the element  $R$  in any particular representation  $\Gamma$  of the group  $G$  then the sum of the elements in the main diagonal of  $D(R)$ —that is, the *trace* of  $D(R)$ —is the *characteristic* of  $R$  for that particular representation; it is usually denoted by the symbol  $\chi(R)$ . When  $R$  runs through all the group elements there results a set of  $g$  numbers, which may be interpreted as a vector in the  $g$  dimensional space of the group elements. As is well known the trace of a matrix is invariant under transformations. Hence it is a fact that every element in the same class will have the same characteristic in any particular representation, and it is customary therefore in general to write  $\chi(C_j)$  in lieu of  $\chi(R)$  where  $C_j$  represents the class of elements to which  $R$  belongs. If therefore  $G$  contains  $k$  classes,  $C_1, C_2, \dots, C_k$ , containing  $g_1, g_2, \dots, g_k$  elements respectively, where of course  $g_1 + g_2 + \dots + g_k = g$ , we shall have for a particular representation the  $k$  numbers  $\chi(C_1), \chi(C_2), \dots, \chi(C_k)$ , and these may be interpreted as a vector in the  $k$  dimensional space of the classes. This vector is sometimes called a character of  $G$ .  $G$  would thus have a character for each representation, but we shall reserve the term for what are sometimes called simple characters, that is the characters of the  $k$  irreducible representations  $D^{(1)}(A), D^{(2)}(A), \dots, D^{(k)}(A)$ . Characters of other representations can be called compound characters or generalized characters if it is necessary to refer to them. It is evident that two equivalent irreducible representations have the same character. We shall use a superscript to denote the particular representation which gives rise to a character and a subscript to denote the particular class to which a characteristic belongs, thus  $\chi^{(i)}(C_j)$  represents the characteristic of each

element in the class  $C_j$  for the representation  $D^{(i)}(A)$ .

Evidently if we are in possession of all the irreducible representations of  $G$  the process of writing down a table of characters, essentially a matrix of  $k$  columns, will be a trivial one. To obtain the irreducible representations may except for elementary cases be a tedious process. However, there are ways by which the characters may be obtained directly. These too may become laborious if we proceed to too complicated groups. Methods of simplifying and improving such processes will delight and inspire or vex and impede the pure mathematician, as the case may be. However, the physicist frequently makes use of only those characters which are most readily obtainable and so his case is not a hopeless one. For the symmetric group in particular the necessary characters are easily obtainable.

We make a few general observations concerning the characters of the symmetric group. We observe first that the permutations of the symmetric group may be divided into two equal sub-sets, the even permutations and the odd permutations. The even permutations are those which leave invariant the alternating function

$$P = (x_1 - x_2)(x_1 - x_3)(x_1 - x_4) \cdots (x_1 - x_n) \\ (x_2 - x_3)(x_2 - x_4) \cdots (x_2 - x_n) \\ \dots\dots\dots \\ (x_{n-1} - x_n)$$

The odd permutations are those which reverse the sign of  $P$ . Evidently the even permutations form a group, the alternating group on  $n$  letters. We have noted that there is a representation of the symmetric group corresponding to each partition of  $n$ . Let us make a diagram corresponding to a partition, say the partition  $(\lambda_1, \lambda_2, \lambda_3, \dots)$ . Let us put  $\lambda_1$  dots equally spaced in a horizontal row. Immediately below let us place  $\lambda_2$  dots the leftmost one immediately below the leftmost one in the top row and put each dot below one in the line above. We place  $\lambda_3$  dots in a similar manner in the third row and so on. We have thus constructed a sort of triangular matrix of dots, and to every partition there will correspond such a diagram. If we transpose one of these matrices about its main diagonal, we will change it into another

one of the diagrams. Two partitions whose diagrams are so related are called associated partitions. Thus the partition  $(5, 2)$  of 7 with the diagram  $\dots\dots$  is associated with the

partition  $(2, 2, 1, 1, 1)$  of 7 which has  $\dots$  as

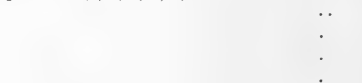

its diagram. In case the dot matrix is symmetric about the main diagonal, the partition is said to be self-associated. Thus  $(4, 1, 1, 1)$  with the diagram  $\dots\dots$  is a self-associated

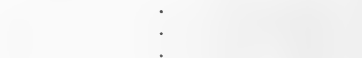

partition of 7. The representations corresponding to associated partitions are associated representations; a characteristic of an even class in a representation is the same as the characteristic of that same class in the associated representation, while a characteristic of an odd class is the negative of the characteristic in the associated representation. We thus see that when we know the character of a representation, we at once know the character of the associated representation. We observe also that it follows that the characteristics of the odd classes in a self-associated representation are all zero.

We observe that we always let  $C_1$  represent the class consisting of the identity alone and that hence  $\chi^i(C_1)$  is always the dimension of the representation  $D^{(i)}(A)$ , being the trace of the identity matrix. We tabulate below the tables of characters for the symmetric group on four symbols and on five symbols:

Partition \ Class	(4)	(3, 1)	(2, 2)	(2, 1, 1)	(1, 1, 1, 1)	Number of elements in class	Partition giving rise to class
	†	††	*	††	†		
(4, 0, 0, 0) <sub>s</sub>	1	3	2	3	1	1	(4)
(2, 1, 0, 0) <sub>s</sub>	1	1	0	-1	-1	6	(3, 1)
(1, 0, 1, 0) <sub>s</sub>	1	0	-1	0	1	8	(2, 1, 1)
(0, 2, 0, 0) <sub>s</sub>	1	-1	2	-1	1	3	(2, 2)
(0, 0, 0, 1) <sub>s</sub>	1	-1	0	1	-1	6	(1, 1, 1, 1)

† associated partitions.  
 †† associated partitions.  
 \* self associated partition.

Partition Class	(5) †	(4, 1) ††	(3, 2) †††	(3, 1, 1) *	(2, 2, 1) †††	(2, 1, 1) 1) ††	(1, 1, 1) 1, 1) †	No. of elements in class	Partition giving rise to class
	(5, 0, 0, 0, 0) <sub>+</sub>	1	4	5	6	5	4		
(3, 1, 0, 0, 0) <sub>-</sub>	1	2	1	0	-1	-2	-1	10	(4, 1)
(2, 0, 1, 0, 0) <sub>+</sub>	1	1	-1	0	-1	1	1	20	(3, 1, 1)
(1, 2, 0, 0, 0) <sub>+</sub>	1	0	1	-2	1	0	1	15	(3, 2)
(1, 0, 0, 1, 0) <sub>-</sub>	1	0	-1	0	1	0	-1	30	(2, 1, 1, 1)
(0, 1, 1, 0, 0) <sub>-</sub>	1	-1	1	0	-1	1	-1	20	(2, 2, 1)
(0, 0, 0, 0, 1) <sub>+</sub>	1	-1	0	1	0	-1	1	24	(1, 1, 1, 1, 1)

† associated partitions.

†† associated partitions.

††† associated partitions.

\* self-associate partition.

We observe that if  $g$  is the order of the group and  $g_i$  is the number of elements in the Class  $C_i$ ; and that if we multiply the characteristic in each box by  $\sqrt{\frac{g_i}{g}}$  then the resulting matrix will be a unitary matrix—that is we shall have

$$\sum_{k=1}^{k=n} a_{ki} \bar{a}_{kj} = \delta_{ij}$$

and

$$\sum_{k=1}^{k=n} a_{ik} \bar{a}_{jk} = \delta_{ij}.$$

So far we have discussed the symmetric group, and that is what primarily interests us here. It so happens that the characteristics here are all real so that the unitary property of the matrix of the characters does not become evident. By way of contrast and completeness we give the table of characters for some simple nonsymmetric groups, in particular the "octic" group (a group of order eight which plays an important role in the

theory of the solution of the fourth degree equation), the alternating group on four letters, the simple group of order 168, and the non-cyclic group of order 21. As a permutation group the octic group may be represented as follows.

identity,  $ac \cdot bd, abcd, adcb, ab \cdot cd, ad \cdot bc, ac, bd,$   
 $C_1 \quad C_2 \quad C_3 \quad C_3 \quad C_4 \quad C_4 \quad C_5 \quad C_5$

There are thus five classes and the classes may be enumerated as shown above where the class to which the element belongs is indicated immediately below the class. The table of characters follows:

Representation Class	Representation					Number of elements in class
	$\Gamma_1$	$\Gamma_2$	$\Gamma_3$	$\Gamma_4$	$\Gamma_5$	
$C_1$	1	2	1	1	1	3
$C_2$	1	-2	1	1	1	1
$C_3$	1	0	-1	-1	1	2
$C_4$	1	0	-1	1	-1	2
$C_5$	1	0	1	-1	-1	2

Representation Class	Representation						Number of elements in class
	$\Gamma_1$	$\Gamma_2$	$\Gamma_3$	$\Gamma_4$	$\Gamma_5$	$\Gamma_6$	
identity	1	6	7	8	3	3	1
elements of order 2	1	2	-1	0	-1	-1	21
elements of order 4	1	0	-1	0	1	1	42
elements of order 3	1	0	1	-1	0	0	56
24 elements of order 7	1	-1	0	1	$\frac{1}{2}(-1 + i\sqrt{7})$	$\frac{1}{2}(-1 - i\sqrt{7})$	24
inverses of elements in above class	1	-1	0	1	$\frac{1}{2}(-1 - i\sqrt{7})$	$\frac{1}{2}(-1 + i\sqrt{7})$	24

The alternating group on 4 letters (also known as the tetrahedral group) is as follows:

iden;  $ab \cdot cd, ac \cdot bd, ad \cdot bc; abc, acd, adb, bdc; acb, adc, abd, bcd$   
 $C_1 \quad C_2 \quad C_2 \quad C_2 \quad C_3 \quad C_2 \quad C_3 \quad C_3 \quad C_4 \quad C_4 \quad C_4 \quad C_4$

The table of characters:

Representation \ Class	(4)	(3, 1)	(2, 2)	(2, 2)'	No. of elements in class
$C_1$	1	3	1	1	1
$C_2$	1	-1	1	1	3
$C_3$	1	0	$\omega$	$\omega^2$	4
$C_4$	1	0	$\omega^2$	$\omega$	4

The simple group of order 168 is tabulated at the foot of page 125.

The noncyclic group of order 21:

Representation \ Class	$\Gamma_1$	$\Gamma_2$	$\Gamma_3$	$\Gamma_4$	$\Gamma_5$	Number of Elements in Class
identity	1	1	1	3	3	1
seven elements of order 3	1	$\omega$	$\omega^2$	0	0	7
inverses of above elements	1	$\omega^2$	$\omega$	0	0	7
three elements of order 7	1	1	1	$\frac{1}{2}(-1 + i\sqrt{7})$	$\frac{1}{2}(-1 - i\sqrt{7})$	3
inverses of above elements	1	1	1	$\frac{1}{2}(-1 - i\sqrt{7})$	$\frac{1}{2}(-1 + i\sqrt{7})$	3

So far we have dealt with finite groups. We consider infinite groups, in particular continuous groups. The set of all nonsingular  $n$ -rowed matrices with elements in the complex number field constitutes a group, the full linear group of dimension  $n$ . We shall be concerned with certain subgroups thereof. In particular we shall consider those groups in which the elements are continuous functions of one or more parameters, whose domain of variability may be disconnected or simply or multiply connected. If the domain is connected, the group is a simply continuous group, otherwise a mixed continuous group. We assume that the elements of the matrices possess derivatives of all necessary orders with regard to the parameters.

Moreover, we shall consider groups whose matrices are unitary—the unitary groups; and also we shall consider groups whose determinants are all 1—the unimodular groups. If we consider groups whose matrices are both, we have the unimodular unitary groups.

Ever since we studied elementary analytic geometry we have been familiar with the rotations of the Cartesian plane about the origin. This group is the two dimensional pure rotation group. The matrices are all real orthogonal (hence unitary) and have determinant one. Hence the pure rotation group is real, unimodular and unitary. It is a fact that the real unimodular orthogonal group of dimension  $n$  will always have exactly  $\frac{1}{2}n(n-1)$  independent parameters; hence in the present case a single parameter. (If we add the real orthogonal transformations of determinant  $-1$ , we have the rotation reflection group and we now have two parameters.) The familiar transformation

$$x' = x \cos \phi - y \sin \phi$$

$$y' = x \sin \phi + y \cos \phi$$

with the matrix  $\begin{pmatrix} \cos \phi & -\sin \phi \\ \sin \phi & \cos \phi \end{pmatrix}$

gives us the rotation group the parameter being  $\phi$  where  $-\pi < \phi \leq \pi$  a simply connected domain. There is only one parameter and it appears additively in the group, that is, if  $\{\phi\}$  represents the element whose parameter is  $\phi$  then  $\{\phi + \phi'\} = \{\phi\}\{\phi'\}$ . The parameter appears additively and the group is abelian, every element thus being in a class by itself. We seek the non-equivalent irreducible representations of the two-dimensional pure rotation group. They are  $(e^{im\phi})$  where  $\phi$  is the parameter and  $m$  is a rational integer,  $m = \dots, -2, -1, 0, 1, 2, \dots$ . This time we are concerned with the actual representations rather than merely with the characteristics, though of course the characteristic can immediately be read off.

If we extend the pure rotation group to include also the matrices of determinant  $-1$  we have the entire "rotation-reflection" group, the aggregate of all real orthogonal

matrices. We may get them by adding to the above matrices the matrices

$$\begin{pmatrix} -\cos\phi & \sin\phi \\ \sin\phi & \cos\phi \end{pmatrix}$$

We now have two parameters, the continuous parameter  $\phi$  as before and the discrete parameter  $d$  which may take either of the values 1 or  $-1$ ; and the set of matrices may be included in the formula

$$\{\phi, d\} = \begin{pmatrix} d\cos\phi & -d\sin\phi \\ \sin\phi & \cos\phi \end{pmatrix}$$

The group is no longer abelian—the set of matrices which constitute the pure rotations no longer consists of matrices each of which is a class by itself, for  $\{\phi, 1\}$  and  $\{-\phi, 1\}$  now constitute a class. Also all elements

$$\begin{pmatrix} -\cos\phi & \sin\phi \\ \sin\phi & \cos\phi \end{pmatrix}$$

are in a class. The group is now a mixed continuous group since the domain of variability of the parameters is no longer connected.

We have of course the trivial representation of the rotation reflection group in which every element corresponds to the matrix (1) and also the one-dimensional representation in which the matrices

$\begin{pmatrix} \cos\phi & -\sin\phi \\ \sin\phi & \cos\phi \end{pmatrix}$  correspond to (1) while the

matrices  $\begin{pmatrix} -\cos\phi & \sin\phi \\ \sin\phi & \cos\phi \end{pmatrix}$  correspond to  $(-1)$ .

The other irreducible representations are two dimensional and in them we have the correspondence

$$\begin{pmatrix} \cos\phi & -\sin\phi \\ \sin\phi & \cos\phi \end{pmatrix} \leftrightarrow \begin{pmatrix} e^{-i\mu\phi} & 0 \\ 0 & e^{i\mu\phi} \end{pmatrix}$$

$$\begin{pmatrix} -\cos\phi & \sin\phi \\ \sin\phi & \cos\phi \end{pmatrix} \leftrightarrow \begin{pmatrix} 0 & e^{i\mu\phi} \\ e^{-i\mu\phi} & 0 \end{pmatrix}$$

for all properly positive integral values of  $m$ .

We now consider the irreducible represen-

tations of the three dimensional pure rotation group and of the three dimensional rotation-reflection group.

As we have observed the three dimensional pure rotation group (real orthogonal matrices with determinant  $+1$ ) has  $\frac{1}{2}3(3-1) = 3$  parameters. There is a very close relation between the representation of this group and the representations of the *unimodular unitary* group in two dimensions. From the latter we may get the former; it is also true that from the latter we may get what are called the "ambiguous" representations of the pure rotation group—they are not truly representations but they play an important role in the theory of the spin of the electron. We have an irreducible representation of the pure rotation group for each zero or positive integral value of  $j$  as given by the expression below. The rotation is here given by its Eulerean angle  $\{\alpha, \beta, \gamma\}$  the three parameters of the group. The dimension is  $2j+1$ , and  $\mu'$  and  $\mu$  take on the  $2j+1$  values  $-j, -j+1, \dots, -2, -1, 0, 1, 2, \dots, j-1, j$ .  $\mu'$  gives the row of the matrix,  $\mu$  the column, so that the element in the upper left-hand corner is in the position  $-j, -j$ ; the element in the upper right corner is in the position  $-j, j$ . The representation is denoted by  $D^{(j)}\{\alpha, \beta, \gamma\}$ . The element in the  $\mu', \mu$  position is given by the expression

$$D^{(j)}(\{\alpha\beta\gamma\})_{\mu'\mu} = \sum_x (-1)^x \cdot \frac{x\sqrt{(j+\mu)!(j-\mu)!(j+\mu')!(j-\mu')!}}{(j-\mu'-x)!(j+\mu-x)!x!(x+\mu'-\mu)!} \cdot e^{i\mu'\alpha} (\cos \frac{1}{2}\beta)^{2j+\mu-\mu'-2x} (\sin \frac{1}{2}\beta)^{2x+\mu'-\mu} e^{i\mu\gamma}$$

where

$$\text{larger of } \begin{Bmatrix} 0 \\ \mu - \mu' \end{Bmatrix} \leq x \leq \text{smaller of } \begin{Bmatrix} j - \mu \\ j + \mu \end{Bmatrix}$$

For  $j=0$  this reduces to the trivial representation in which every rotation corresponds to the one-dimensional matrix (1). For  $j=1$  this representation is three dimensional and the matrix corresponding to the rotation  $\{\alpha, \beta, \gamma\}$  is given below, the half angles having been changed to integral angles through elementary trigonometric identities:

$$\begin{bmatrix} e^{-i\alpha} \frac{1 + \cos \beta}{2} e^{-i\gamma} & -e^{-i\alpha} \frac{\sin \beta}{\sqrt{2}} & e^{-i\alpha} \frac{1 - \cos \beta}{2} e^{i\gamma} \\ \frac{1}{\sqrt{2}} \sin \beta e^{-i\gamma} & \cos \beta & -\frac{1}{\sqrt{2}} \sin \beta e^{i\gamma} \\ e^{i\alpha} \frac{1 - \cos \beta}{2} e^{-i\gamma} & e^{i\alpha} \frac{\sin \beta}{\sqrt{2}} & e^{i\alpha} \frac{1 + \cos \beta}{2} e^{i\gamma} \end{bmatrix}$$

For half integral values of  $j$  we have the ambiguous representation the form of the general element of which is just like that for integral values of  $j$  except that before each element there appears the  $\pm$  sign. This does not mean that the sign has just not yet been chosen and will be chosen to suit our purposes. It is impossible to do this. The sign must be left ambiguous and we pick whichever one will fit into the particular object we have in mind. This time  $\mu'$  and  $\mu$  take the half-integral values  $-j, -j+1, \dots, -\frac{1}{2}, \frac{1}{2}, \dots, j$ . Thus if  $j$  is  $\frac{1}{2}$  the representation is of dimension  $2j + 1 = 2$  and the four positions of the representing matrices are as shown:  $-\frac{1}{2}, -\frac{1}{2}, -\frac{1}{2}, \frac{1}{2}$ . The actual representation when  $j = \frac{1}{2}$  is shown:

$$\begin{bmatrix} e^{-\frac{1}{2}i\alpha} \cos \frac{\beta}{2} e^{-\frac{1}{2}i\gamma} & -e^{-\frac{1}{2}i\alpha} \sin \frac{\beta}{2} e^{\frac{1}{2}i\gamma} \\ e^{\frac{1}{2}i\alpha} \sin \frac{\beta}{2} e^{-\frac{1}{2}i\gamma} & e^{\frac{1}{2}i\alpha} \cos \frac{\beta}{2} e^{\frac{1}{2}i\gamma} \end{bmatrix}$$

The three dimensional rotation reflection group may be thought of as the direct product of the three dimensional pure rotation group and the three dimensional reflection group consisting of the two matrices

$$I = \begin{pmatrix} 1 & 0 & 0 \\ 0 & 1 & 0 \\ 0 & 0 & 1 \end{pmatrix} \text{ and } -I = \begin{pmatrix} -1 & 0 & 0 \\ 0 & -1 & 0 \\ 0 & 0 & -1 \end{pmatrix}$$

(A group  $G$  is the direct product of  $H$  and  $K$  if  $H$  and  $K$  are subgroups of  $G$ , have no common element except the identity, if every element of  $H$  is commutative with every element of  $K$  and if every element of  $G$  equals the product of an element of  $H$  and an element of  $K$ ). If  $G$  is the direct product of  $H$  and  $K$ , that is, in symbols, if  $G = H \times K$ , and if  $D_h^{(j)}(s)$  is an irreducible representation of  $H$  and  $D_k^{(j)}(t)$  is an irreducible representation of  $K$  then an irreducible representation

of  $G$  is obtained by making the element  $st$  of  $G$  correspond to the matrix  $D_h^{(j)}(s) \times D_k^{(j)}(t)$ , that is to the Kronecker product of the matrices, one from the representation of  $H$  and the other from the representation of  $K$ . It is thus seen that the number of irreducible representations of  $G$  equals the product of the number of irreducible representations of  $H$  multiplied by the number of irreducible representations of  $K$  (provided of course that in each case the number of representations is finite). Since  $H$  and  $K$  are commutative it might seem that we could obtain another representation by taking the Kronecker products in the reverse order, but it is a fact that the representation  $D_h^{(j)}(s) \times D_k^{(j)}(t)$  is equivalent to (may be transformed into) the representation  $D_k^{(j)}(t) \times D_h^{(j)}(s)$ .

Evidently the three dimensional reflection group has two non-equivalent irreducible representations, the trivial one in which both  $I$  and  $-I$  correspond to the matrix (1), and the one in which  $I$  corresponds to the matrix (1) and  $-I$  corresponds to the matrix  $(-1)$ . Thus the rotation reflection group has a representation in which each element of the rotation group corresponds to the matrix to which it corresponds in a given representation of the rotation group, while the negative of each element of the rotation group also corresponds to the matrix to which the original element corresponds in the representation of the rotation group. Also the rotation reflection group has a representation in which each element of the rotation group corresponds to the matrix to which it corresponds in a given representation of the rotation group, while the negative of each element of the rotation group corresponds to the negative of the matrix to which the element of the rotation group corresponds. Thus are obtained from the irreducible representations of the rotation group the irreducible representations of the rotation reflection group.

It is a fact that the Schrödinger equation  $H\Psi = E \cdot \Psi$  associated with an atomic system consisting of a nucleus and  $n$  electrons in their orbits about the nucleus is "invariant under a group" consisting of the direct product of the symmetric group on  $n$  elements and the rotation group and the reflection group. It is a fact that the energy levels for which this equation has a solution are the "eigen-



values" of the system and that associated with each eigenvalue is a set of linearly independent "eigenfunctions" which gives the probabilities for a certain state of the atom. The group-theoretic properties discussed above, in particular the representations of the rotation group and of the reflection group and the characters of the symmetric group, have been employed to shed light on this important question of the state of the atom; but the complete story of that application is too long to be told here.

MATHEMATICS.—*On an equation of Neményi and Truesdell.* D. S. MITRINOVITCH, Institute of Mathematics, Skopje, Jugoslavia. (Communicated by C. Truesdell.)

1. Consider the differential equation

$$\frac{F''}{F} + (n^2 - 1) \frac{f''}{f} = 0, \quad (n > 1) \quad (1)$$

where  $n$  is a positive integer,  $F = F(z)$ ,  $f = f(z)$ , and primes denote differentiation with respect to  $z$ . P. Neményi and C. Truesdell<sup>1</sup> have reduced the general equilibrium problem in the membrane theory of shells of revolution to the integration of this single equation. I have recently given a procedure<sup>2</sup> which systematically yields cases in which (1) can be integrated by quadratures. In this note I present another method of integration for the equation (1).

2. By introducing the changes of variable

$$F = \exp\left(\int G dz\right), \quad f = \exp\left(\int g dz\right),$$

we may put (1) into the form

<sup>1</sup> Cf. NEMÉNYI, P., *Bygningsstatistiske Meddelelser*, 1936; NEMÉNYI, P., and TRUESDELL, C., *Proc. Nat. Acad. Sci.* **29**: 159-162. 1943; TRUESDELL, C., *Trans. Amer. Math. Soc.* **58**: 96-166. 1945; **61**, 128-133. 1947.

<sup>2</sup> MITRINOVITCH, D. S., *Comptes Rendus Acad. Sci. Paris* **231**: 327-328. 1950.

## BIBLIOGRAPHY

- BLICHFELDT, H. F. *Finite collineation groups.*  
 BURNSIDE, W. *Theory of groups of finite order.*  
 LITTLEWOOD, D. E. *The theory of group characters.*  
 MURNAGHAN, F. D. *The theory of group representations.*  
 VAN DER WAERDEN, B. L. *Die gruppentheoretische Methode in der Quantenmechanik.*  
 WEYL, H. *The classical groups.*  
 WEYL, H., and ROBINSON, H. P. *The theory of groups and quantum mechanics.*  
 WIGNER, E. *Gruppentheorie und ihre Anwendung auf die Quantenmechanik der Atomspektren.*

$$(G - \lambda g)' + G^2 - \lambda g^2 = 0, \quad (\lambda = 1 - n^2),$$

or, equivalently,

$$\theta' + G^2 - \lambda g^2 = 0, \quad (2)$$

where we have put

$$G - \lambda g = \theta. \quad (3)$$

From equations (2) and (3) we have

$$G = \frac{-\theta \pm \Delta}{\lambda - 1}, \quad g = \frac{-\lambda\theta \pm \Delta}{\lambda(\lambda - 1)}$$

$$(\Delta = +\sqrt{\lambda\theta^2 + (\lambda - \lambda^2)\theta'}),$$

where the sign  $\pm$  is to be taken alike in the two expressions.

Consequently a solution of (1) is given by the formulae

$$F = A \exp\left(\int_{z_0}^z G dz\right), \quad f = B \exp\left(\int_{z_0}^z g dz\right),$$

where  $A$  and  $B$  are two constants of integration,  $z_0$  is a suitably chosen numerical constant.  $G$  and  $g$  are two functions of  $z$  defined by (4), in which there occurs a function of  $z$ , namely  $\theta(z)$ , which is completely arbitrary.

3. In a study now in press I apply the method of §2 to differential equations of a much more general type.

ARCHEOLOGY.—*Notes on aboriginal pottery from Montana.*<sup>1</sup> WALDO R. WEDEL,  
U. S. National Museum.

Aboriginal pottery from Montana is no longer news to students of Plains prehistory and ethnography. Since 1940 its occurrence in various localities throughout the State has been noted several times in the archeological literature. Moreover, most historic Indian tribes of the region, including specifically the Blackfoot, Gros Ventres, Sarsi, Shoshoni, and Assiniboin, seem to have retained traditions recalling a time when they made pottery. Even the Crow, for whom ethnographers have apparently recorded no such traditions, are coming under progressively deeper suspicion of having been potters since their still undated arrival in the drainage of the Yellowstone.

The ethnographic data bearing on this subject have been well summarized, and some of their implications discussed, by Ewers (1945). The archeological evidences, which promise to give unsuspected historic depth to the native use of pottery on the headwaters of the Missouri River system, represent mainly materials and data gathered during the 1930's in course of work relief programs. Much of this latter information, which is of primary importance for the understanding of Montana prehistory, as well as some scattering data more recently gathered by River Basin Surveys parties, unfortunately still remains unpublished. From what is in print (Mulloy, 1942, 1945; Nelson, 1942, 1943), however, it is clear that pottery-using peoples have at one time or another scattered their traces, if thinly, throughout a number of Montana's stream valleys westward almost to the continental divide. Still to be determined, preferably on the basis of larger and better controlled samplings than are at present available, are the exact nature and chronological positions of the several pottery complexes apparently indicated, as well as the associated artifact types and subsistence economies. The location of the region in the heart of the erstwhile "potteryless" Plains culture area lends more than usual interest to the problems raised.

<sup>1</sup> Published by permission of the Secretary, Smithsonian Institution.

In the present discussion I do not intend to answer any of the questions implied above. My purpose is rather to put on record a few descriptive notes regarding several hitherto unreported or undescribed finds of pottery in northwestern Montana, all in the Missouri River watershed. These I have compared provisionally with materials already described from other localities lying mainly to the south and east, and also with what has been suggested or reconstructed from tribal traditions or historic documents regarding pottery of the historic Indians in the region. Though I have not personally examined the sites from which the material at hand is reported to have come, such information as has been furnished me seems to warrant the present notice.

The material immediately under consideration consists of small samples only and obviously does not give a complete picture of the material culture complex presumably represented in each case.<sup>2</sup> It includes a series of less than 100 sherds from a site near Ethridge, in Toole County; two smaller lots from two locations in Teton and Cascade Counties; and reports on two other sites in Chouteau and Cascade Counties. There is also a series of nearly 200 sherds from a cairn on the Crow Indian Reservation south of Billings. Only this latter series can be said to have been collected under anything like controlled conditions, or by a professional archeologist. The descriptive notes that follow are based on visual examination or, at most, on use of a hand lens.

<sup>2</sup> The Ethridge specimens were collected by Giles Ortscheid, formerly of Cut Bank, who turned them over to Claude Schaeffer, Museum of the Plains Indian, Browning, by whom they were forwarded to me. The specimens and records from Teton, Cascade, and Chouteau Counties were furnished by J. Robert Wells, formerly of Great Falls, to John C. Ewers, associate curator of ethnology, U. S. National Museum, who turned them over to me. The specimens from the Crow Indian Reservation were excavated by N. C. Nelson in 1941 for the American Museum of Natural History, and were sent me on loan by J. A. Ford, assistant curator of North American archeology at that institution. I am indebted to all these men, and particularly to Schaeffer, Ewers, and Ford, for their willingness to place these materials at my disposal and to supply relevant information.

*Ethridge Site, Toole County.*—In the sample forwarded to me from this site by Schaeffer there are approximately 100 sherds, plus arrowpoints, scrapers, other chipped flints, shell fragments, and, interestingly enough, three fragments of brass. They are from a camp site near a bison fall, situated 8 miles (airline) northwest of Ethridge, in the Marias River drainage. The bison bones and cultural materials are found at the lower end of a deep cleft in an east-facing escarpment some 200 feet high. According to Ortscheid (letter to Schaeffer, May 18, 1950), the sherds "seemed to be mostly 5 or 6 inches below the surface and some on the surface where the wind had blown clean spots. The copper or brass fragments were close to the surface. The stone chips and points . . . were mixed indiscriminately from surface to undisturbed soil, which varied from six inches to a couple of feet in places . . . most of the material was from the center of the camp-site [which] covers several acres."

With regard to paste, color range, texture, and other technological details, examination with a hand lens seems to reveal no significant variation among the sherds at hand. Like much Northern Plains pottery, these usually have a gray to dark gray paste, occasionally fired to a light gray, brown, or buff on the exterior surface. Inclusions vary in amount and coarseness, even within individual sherds. Characteristically, they consist of crushed granite in medium to coarse angular particles, less commonly of rounded and water-worn gravel. They are usually only moderately abundant, and do not show on sherd surfaces. Exterior hardness varies from 3 to 4, occasionally reaching 4.5. Interior surfaces are rather rough and uneven. Carbonized material (presumed to be food remains) adhere to the inner surfaces of many fragments. The sherds vary in thickness from 6 to 12 mm; most are in the neighborhood of 8 mm. There are no recognizable base fragments, handles, or other constructional features, nor is there anything to indicate the range in vessel shapes and sizes.

With respect to surface finish and treatment, three main groups may be recognized. Fourteen sherds, including three rims from at least two vessels, are evidently fabric-marked (Fig. 1, A-F). These sherds range from 9 to 12 mm in thickness, which is considerably heavier than any other series present. The exterior surfaces have been strongly impressed by some fabric that left a dimpled texture, which occasionally somewhat

suggests knotting or a net impression. Sherds in the national collections with strikingly similar surface treatment come from a Middle Woodland site near Gala, Va. (Holmes, 1903, pl. 133, upper right). This is an eastern Woodlands pottery trait; so far as my observations go, it is not common, and has apparently not been heretofore reported, in the Plains or on upper Missouri Valley potterywares.

Thirty-eight sherds, of which 16 are rim pieces, I have somewhat hesitantly classed as cord-roughened (Fig. 1, G-J). On some pieces there is no doubt that the impressions were made with a twisted cord or other fibrous element; in others, superficially very similar in appearance, the impressions do not conclusively show twisting of the element used. The group is rather variable; some sherds show deep fine impressions, whereas others have the impressions widely spaced or nearly obliterated. Despite this variability, most of the sherds would be assigned with little hesitation to the cord-roughened category, if they had been taken from a prehistoric Central Plains village site.

Eighteen sherds, all body fragments, are plain surfaced. Surfaces are moderately well smoothed, but often uneven and never polished. Occasionally there is some unevenness suggesting smoothed-over cord-roughening or possibly simple stamping.

Not included in the above counts, are about a dozen body sherds which can perhaps be described as weakly carinate. On each there is a perceptible shoulder bearing vertical or occasionally diagonal notches (Fig. 2, A-C), made with some thin-ended or triangulate-tipped instrument, and spaced usually at intervals of about  $\frac{3}{8}$  inch. Most of these sherds are plain ware. Three are what I have tentatively called cord-roughened, and one of these latter bears diagonal notches made by impressing a cord-wrapped instrument (Fig. 2, G).

Significantly enough, there are in the whole series only two or three sherds, at most, which can be called simple stamped or fluted on the exterior surface. A number of small fragments cannot be satisfactorily identified as to surface treatment, and so are omitted from my counts and determinations.

Rims are characteristically thickened or somewhat bulbous in profile, with horizontal or out-sloping flattened upper lip surface. Most of them seem to conform rather closely to Mulloy's rims

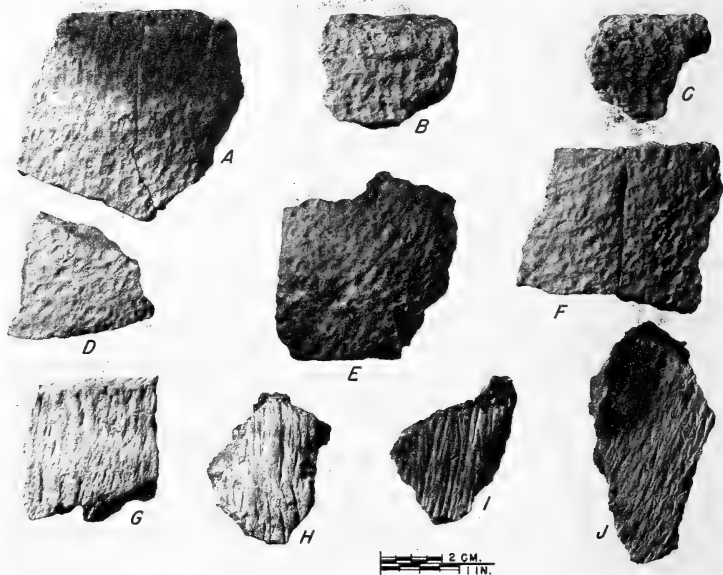

FIG. 1.—Potsherds from camp site near Ethridge, Mont.: A-F, fabric-impressed; G-J, cord-roughened.

of class A form at the Hagen site (Mulloy, 1942, p. 18). So far as I can see in the very limited sample at hand, there is no correlation between rim form, lip, or other related features and the type of surface treatment on the sherds. On cord-roughened rimsherds the flattened lip may be plain, weakly cord-roughened, or carelessly incised. On plain sherds the outer lip edge is sometimes notched; in two instances, the lip panel bears diagonal impressions made with a cord-wrapped rod (Fig. 2, D, F); and in a third the same treatment was applied with a loosely wrapped tool to the outer surface of the neck below the flat panel (Fig. 2, E).

The material culture complex of which the above described sherds were a part is inadequately represented by the specimens at hand. It seems to include, however, numerous small, triangular projectile points, averaging under 25 mm in length, with straight to slightly concave base and a single pair of side notches just above the

base. Three or four are unnotched, and perhaps an equal number can be classed as stemmed or corner-notched; none shows base notching. Materials used include chalcedony, cherts of various colors, jasper, obsidian, and quartzite. All the points I have seen appear to be of types said to be common at many bison-kills of the Montana region, but with three exceptions they are perhaps somewhat less carefully made. They presumably represent the products of late prehistoric or protohistoric natives of the region.

There appears to be nothing distinctive about the scrapers and other chipped flints sent me from the Ethridge site.

The three pieces of brass, of course, must be attributed to Caucasian contact or influence, but it is not certain at the moment that they actually belong to the same complex as the sherds. The collector's letter (Ortscheid to Schaeffer, May 18, 1950) says they were "close to the surface" of the site. They are possibly intrusive; or they may

have been left by some later group than that responsible for the pottery. There is nothing to indicate the nature of the objects from which the fragments came.

*Sites in Cascade, Teton, and Chouteau Counties.*—Sherds from two sites in Cascade and Teton Counties, and notes on other occurrences in the same general region, were sent to Ewers in September 1947, by J. Robert Wells, then of Great Falls. Ten of the sherds are said to have been found in the summer of 1933 "near a bison trap on the south-facing sandstone escarpment of what is locally called the 'second bench' between Ulm and Vaughn, Cascade County." There is no further description of the locale of discovery.

The sherds are mostly small, the largest not exceeding two inches in maximum diameter. In thickness they range from 5 to 8 mm; in hardness, from 3 to 4. Paste again is gray to dark gray in color, with a fine granular appearance. The aplastic consists of gravel, mostly or entirely in rounded particles. The three largest sherds show impressions identical with what I have classed in the Ethridge material as cord-roughening on the exterior surface; and all but one of the remaining fragments, in color, texture, surface finish, and other particulars, seem to be from vessels of similar construction and appear-

ance. The single exception, though small and inconclusive, shows several flutings somewhat reminiscent of nearly obliterated simple stamp impressions. Sherd interiors are usually uneven and only moderately well finished. There are no rim fragments.

From the second site, described only as being "near to Chouteau in Pondera [Teton] County . . . not over two miles approximately south from the town," there is a single large plain body sherd. This is remarkable chiefly for its thickness of 15 mm, which far exceeds any of the other Montana sherds which have come under my scrutiny. It has a gray core, which becomes light buff to brown on the surfaces. Temper consists of quartz, mostly in angular particles. The piece is well-fired and hard.

Wells's letter of June 11, 1945, to Ewers, first reporting these pottery finds, notes two other occurrences; from neither are there any specimens at hand. One of these finds was "in the 'cut bank' of the Missouri River at the Fair Grounds of Fort Benton, Chouteau County." Here, according to Mr. Wells, "I found remains suggestive of the interrupted preparation of a meal. Some 18 inches below the present land surface I noticed a short stratum of charcoal upon which rested what appeared to be the flattened fragments of a cooking

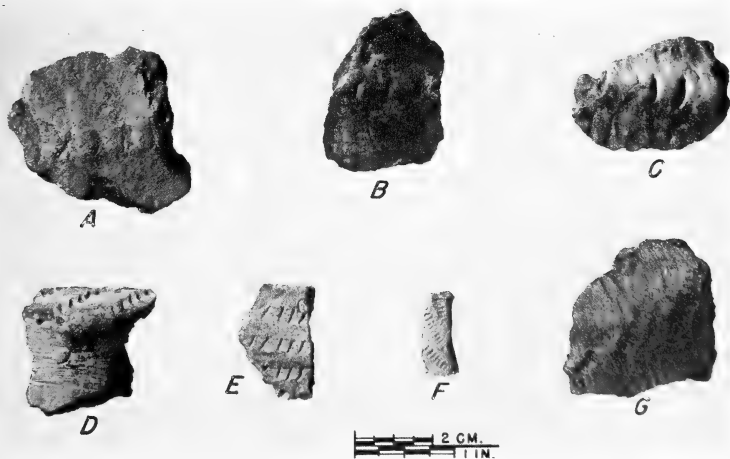

FIG. 2.—Potsherds from camp site near Ethridge, Montana. A-C, carinate with punctations; D-G, cord-wrapped rod-impressed.

pot mixed with several split bison bones. Preservation of the sherds was so poor that I am not sure they were kept. The presence of stone implements together with brass buttons upon about the same level might indicate a date near to the early historic period for these remains."

Also in Cascade County is another sherd-bearing site which "occupies the triangular piece of land west of the Missouri River and south of its tributary, the Sun River, near the mouth of the latter. This tract, now the grounds of the Meadowlark Country Club of Great Falls, was then (about 1920) under cultivation and a very fruitful source of artifacts especially in the fall and spring when the fields were bare. I had seen numerous sherds there on the surface before. . . . I recognized them for what they were. After this lapse of years I can only describe them as small, some  $\frac{1}{4}$  to  $\frac{3}{8}$  inch in thickness, gray, fairly hard, and without sufficient shape to serve as criteria for judging as to the form of the vessels from which they came. If memory serves, the external surfaces, without exception, showed markings which I considered indicative of shaping with a paddle wound with cord approximately  $\frac{1}{8}$  inch in diameter. . . . This site is now mostly occupied by the Country Club golf course, so it would seem unlikely that sherds can now be found there on the surface, but there is still a possibility of finding them embedded in the south bank of the Sun River which was then a 'cut bank' some five or six feet in height. That bank showed evidence of the occupancy of the site for what seemed to me an extended period (intermittent occupancy, I should have said). Charcoal, split bison bones, and lithic artifacts could be observed several feet below the then ground level. I do not, however, recall finding sherds there." (Wells to Ewers, June 11, 1945).

Two items in this last notice are of particular interest. One is the observer's identification of the pottery markings as cord-wrapped paddle impressions; the other is the implication that sherds occurred exclusively or preponderantly on the surface but were not noted in the buried cultural strata partially exposed in the nearby cut bank. Further investigations here would seem to be in order.

*Pottery from the Yellowstone Valley.*—My search of the published literature on Montana archeology has revealed pottery descriptions from four localities in the Yellowstone drainage basin. These include the Hagen site, 5 miles southeast of

Glendive, in Dawson County, excavated by the Montana Archeological Survey and Works Projects Administration and since described in commendable detail and clarity by Mulloy (1942); a rock cairn at Arrow Rock on the Crow Indian Reservation some 35 miles south of Billings, excavated by Nelson (1942, 1943) for the American Museum of Natural History; Thirty Mile Mesa and Pompey's Pillar Cuesta, some 30 or 40 miles north and northeast of Billings; and Pictograph Cave, near Billings. I have seen none of the material from the Hagen site, but Mulloy's well-illustrated report is adequate for present purposes. As elsewhere noted, Nelson's Arrow Rock collection has been placed at my disposal. For the last three localities above enumerated, and findings there by the Montana Archeological Survey, brief notes by Mulloy (1945, p. 520) are available.

The Arrow Rock sherds were taken from a rock cairn situated on the floor of Pryor Canyon and partially trenched by Nelson. Here, in a "mixed earth and boulder deposit," it was found that "at least the upper half of the accumulation was moderately rich in the usual stone objects, glass beads and animal bones. More abundant were bone and shell ornamental items, chiefly beads and pendants. The surprise was the collection of some 200 potsherds." In the absence of word to the contrary, I assume that the glass beads and sherds came from the same levels or horizons within the cairn, and are to be regarded as chronologically associated finds.

Nelson describes the sherds as ranging in surface color from buff to gray, in body thickness from three to nine millimeters, and in rim thickness from nine to fourteen millimeters. The pottery is "sometimes tempered with coarse quartz particles," and "firing is well done." He suggests that "both bowl and jar forms, some with charred food particles adhering to the inside," are apparently represented. On the basis of surface treatment, he recognized three groups of sherds: plain surfaced, 128; corduroy surfaced, 67; and textile impressed (?), 2.

Compared to the Ethridge and Cascade County samples, Nelson's Arrow Rock sherds average generally smaller and thinner, few exceeding 6 mm in thickness. Many have little visible tempering material; others, by contrast, have quartz inclusions that may exceed in size the particles in the more northerly sherds. In surface color, the Arrow Rock sherds seem to run to somewhat

darker tones, seldom showing the light buff or tan exteriors found on the Ethridge sherds. Most of the fragments are appreciably more gritty to the touch than the Ethridge-Cascade County sherds. What Nelson calls "corduroy surfaced" sherds are, without question, Mulloy's fluted or what I have called simple stamped. The impressions, however, are much less regular and conspicuous than those produced by the same or a similar technique among the historic Mandan, Arikara, Pawnee, and other Plains potters. At least one, and quite possibly both, of Nelson's textile-surfaced sherds appear, from plasticene impressions, to be the same as the more plentiful fabric-impressed sherds from Ethridge.

The pottery from the Hagen site, according to Mulloy (1942, pp. 11-38), represents "a single rather well integrated cultural complex." It is described as having a granular, somewhat variable, paste; crushed rock or occasionally sand tempering; a hardness of 3 to 3.5; and a predominantly gray color. Medium-sized jars or ollas seem to be characteristic forms; rims are variable and include both "collared" and "uncollared" forms; lips are wavy or smooth, in the latter case sometimes bearing incised or impressed linear decoration. About half the sherds recovered were plain; another fifth bear fluted or simple stamped surfaces. Incised lines, wrapped-rod impressions, brush roughening, single-cord impressions, check stamping, and dentate stamping occur in decreasing order of frequency. In general technology, in vessel form, in design techniques (especially single-cord impressing, incising, and fluting), and in designs, the ware shows close similarities to the Mandan-Hidatsa pottery tradition. Wrapped rod impressions and dentate stamping, on the other hand, are not Mandan-Hidatsa, and suggest some other eastern influence, possibly on an earlier time level.

Elsewhere in the Yellowstone Valley, the pottery occurrences reported by Mulloy apparently involve, at least in part, wares whose relationships are with the Hagen site complex. Thus, he observes (Mulloy, 1945, p. 520) that "a few fragments of pottery were discovered near the house sites at both Thirty Mile Mesa and Pompey's Pillar Cuesta. They are gray to buff, with coarse paste and sand temper. In some the exterior is fluted, as though it might have been beaten with a thong-wrapped paddle. Pottery of this type occurs in small quantities on the surface in many places throughout this part of the Yellowstone

Valley. It is similar to that of Pictograph Cave IV, an early historic occupation of Pictograph Cave, near Billings." Historic materials, including gun flints and trade beads, were also found at Thirty Mile Mesa; but since all these finds were apparently surface materials, exact associations remain obscure.

*Comparisons.*—The sherds from Ethridge, and those I have described from Cascade County, are closely similar to one another in all respects. Such variations as are apparent in paste, tempering, etc., do not appear to me to be of any great significance; possibly, if the Cascade County sample included as many fragments as are available from Ethridge, the similarity would be even closer. As it is, if the two samples were mixed, it would be impossible, I think, to separate them without recourse to identifying marks. Moreover, the techniques of surface treatment in these two lots are what I would consider predominantly prehistoric in character; a Plains archeologist, inspecting them without previous knowledge as to their provenience would, with little or no hesitation, at once suspect a late prehistoric horizon.

The Ethridge-Cascade County sherds, however, differ appreciably from Nelson's Arrow Rock material. The former are generally thicker, seem to be better fired and more carefully made, show a greater frequency of cord-roughening and fabric-impressing, and a much lower frequency or even near-absence of simple stamping. These differences, though not always easily verbalized, seem marked enough to set the two groups apart, even to a nonspecialist in Plains pottery types. To me, the Arrow Rock sherds, by contrast with the Ethridge-Cascade County materials, have a somewhat "decadent" look that is reminiscent of historically late Plains wares elsewhere—perhaps something like the differences between Dismal River and Upper Republican wares in the central Great Plains.

Having seen and handled none of the Hagen site pottery, I am at some disadvantage in attempting to compare it with the samples at hand. From Mulloy's published description, however, it would appear that with respect to paste, temper, and perhaps other technological details, no striking differences exist between Hagen site pottery and that from the Arrow Rock cairns or from the Ethridge-Cascade County sites. As concerns decorative treatment and surface finish, however, there are far fewer resemblances among the various series. In its heavy emphasis on simple

stamping, the Arrow Rock material is much closer to Hagen site than to the Ethridge-Cascade County sherds. The Hagen site sherds seemingly are thinner than those from Ethridge. Incised decoration, single-cord impressions, dentate-stamping, fluting, and check-stamping are very rare or absent from the Ethridge-Cascade County series; and with the exception of fluting (simple stamping), they are also absent from Nelson's Arrow Rock material. Wrapped-rod impressions occur, as Mulloy (1942, p. 37) has already noted, both at Hagen site and at Ethridge<sup>3</sup>; and so also, apparently, do punctates. More surprising, in light of present knowledge of Montana pottery, is the relative abundance of cord-roughening and fabric-impressing at Ethridge, both of which techniques are apparently absent from the much larger pottery series from the Hagen site. It will be interesting to see whether larger and more carefully controlled pottery samples from the Ethridge locality confirm the presence of these apparently distinguishing characteristics, and the possibly significant differences between pottery from the Yellowstone Valley and that from the Marias-Teton-Sun Rivers locality.

#### DISCUSSION

It is obvious, as I have already indicated, that the sherd samples under discussion here are an inadequate basis for any far-reaching conclusions or broad generalizations, although some speculation seems warranted. They do not suggest that the Montana region was ever one of intensive pottery-making; and it is perhaps significant that in the one stratified site reported to date as pottery-bearing, Pictograph Cave, sherds were found only in the uppermost deposits in association with white contact materials. If this suggested lateness and thinness of occupancy by pottery-making peoples is borne out by findings in other sections of the state, it will perhaps be possible in the not far distant future to allocate most of the ceramic remains to the immediate ancestors of one or another of the historic tribes of the area.

<sup>3</sup> Under date of May 7, 1950, Mulloy informs me as follows concerning his previous examination of a sherd series from Ethridge: "The sample was small and, as I recall, the design elements were typical of the Hagen site and done in cord-wrapped stick. Any of the sherds I saw could have been easily lost in a Hagen site sample. None had cord roughening or fabric impressions."

With regard to the materials reported from the Yellowstone Valley by Mulloy and Nelson, the former has argued cautiously but cogently for a possible Crow authorship. Recency is certainly strongly suggested by the heavy emphasis on such a relatively late ceramic trait as fluting (simple stamping), and by the occasional association of the sherds with trade beads. It is possible that some of the sherd occurrences, such as those noted by Mulloy at pole and log structures in the middle Yellowstone Valley, pertain to hunting parties from tribes normally residing farther to the east or northeast, as for example, the Hidatsa.

The Hagen site, of course, can not be so explained. It was obviously a village of some permanence and length of occupancy. The pottery complex has a great deal in common with that of the late pre-white contact Mandan and Hidatsa, including a number of nearly identical traits; and interesting parallels may be found in other aspects of the material culture complex of the two localities. Linguistic evidence and tribal traditions indicate that the Crow separated at a relatively late date from the Hidatsa; and it seems a not unreasonable view that the Hagen site perhaps represents one of their settlements on the move westward before they had sloughed off entirely their old semi-sedentary mode of village life and pottery-making and when they had not yet acquired the horse. If it can be shown ultimately that the Pryor Valley cairns, where pottery and glass beads occur together, are of Crow origin, the case for the Crow as pottery-using Indians will be considerably strengthened; but such evidence is apparently not yet at hand. At the moment, about all that can be said is that pottery decoratively treated in a style highly characteristic of historic Plains Indian wares is widely distributed throughout portions of Montana which have been, since at least the middle of the 18th century, the range of the Crow Indians; and since the Crow traditionally reached this area from one in which their closest linguistic relatives shared a well-developed pottery tradition, the Crow would seem to be an excellent prospect in the search for the native potters who left the late prehistoric and/or proto-historic ceramic remains in eastern and southern Montana.



But what of the sherd-bearing sites in the Marias-Teton-Sun Rivers area? Here there is no evidence of Crow penetration; and the sherds in the samples at hand seem to indicate something different from the late ware or wares to the south and southeast. What is suggested, moreover, is something quite unlike the crudely fashioned, flat-bottomed, subcylindrical pottery vessels reconstructed by Ewers (1945, p. 295) from historical accounts and tribal traditions of the Blackfoot, historic occupants of the region in question.<sup>4</sup> These latter products are somehow reminiscent of the early forms of metal vessels introduced by white traders, from which, indeed, they may even have been copied by Indians who probably knew nothing of the relatively better-made and technologically superior wares whose vestiges were to be found in some of the old campsites nearby. If the brass fragments at the Ethridge Site are actually associated with the sherds above described, it may be worth while to look further into the possibility of a Gros Ventre or Arapaho origin; but the feeling persists that we are perhaps dealing here with a tradition older than anything that might be associated with one or another of the historic tribes of northern Montana.

I have at the moment no suggestions to offer concerning the affiliations of the Ethridge-Cascade County sherds, except to say that to me they look eastern rather than western, prehistoric rather than historic. They are not strongly reminiscent of a rather mixed lot of sherds which I obtained for the Missouri River Basin Survey in 1947 at site 24RV1, on Big Muddy Creek southwest of Froid, in Roosevelt County, Montana, among which were noted thick, dentate-stamped sherds rather similar to certain Illinois Valley materials. Such traits as dentate-stamping, textile-impressing, cord-roughening, and the wrapped-rod technique

<sup>4</sup> In his letter to me, dated May 7, 1950, Mulloy notes the occurrence of another, possibly somehow related, flat-bottomed potteryware found in campsites in western Montana, in the Wyoming Basin, and in the Great Basin, sometimes in sites which also contain pottery in the Mandan-Hidatsa tradition. He suggests that this may have been brought into the Montana-Wyoming region by the Shoshoni. There is, so far as I know, no published report concerning this curious complex and its significance.

seem to me to argue for a possible eastern Woodland cultural or ethnic thrust into the northwestern Plains, perhaps from the Minnesota region or elsewhere out of the western Great Lakes or upper Mississippi Valley area.

In summary, I am inclined to think that native pottery in the Montana region may be older than would be implied in the assumption that it was brought in by early peoples directly related to one or another of the known historic inhabitants of the region; or alternatively, that some of these arrivals from the east, such as the Arapaho, perhaps came at an earlier time than is commonly supposed. As Mulloy, in his discussion of the Hagen site and its implications, has remarked with reference to westward movements of peoples with a Mandan-Hidatsa culture tradition, although "the only westward movement of which we know is that of the Crow, it is entirely possible that a westward push such as the Crow movement may have taken place on several occasions in the prehistoric period. Small groups may have moved westward to live for a time and later to return or perhaps be absorbed by other groups." It is well established that farther south, in western Kansas, Nebraska, and eastern Colorado, prehistoric horticulturalists and/or potters at one time or another pushed westward many hundreds of miles beyond the immediate valley of the Missouri and even into the High Plains proper. It seems possible that comparable thrusts westward by pottery-using Indians, perhaps during a Late Woodland culture period, may have taken place in Montana as well, though their stay in the region was evidently not as well marked as farther to the south. That full-scale horticultural economies accompanied pottery westward to the continental divide in Montana does not seem likely. The Hagen Site lies at or near the northwestern margin of lands climatically suitable for dependable maize gardening; the Marias-Teton-Sun Rivers locality is far beyond the area of known aboriginal maize-bean-squash horticulture.

Determination of the exact character of the subsistence pattern and general material culture complex of pottery-bearing sites in northern Montana would doubtless assist in

the orderly arranging of the later prehistoric records of human occupancy of the region. It is just possible, too, that here, as elsewhere in the Great Plains where systematic archeology has been done, current concepts of local prehistory would be shown to be in need of some overhauling.

## LITERATURE CITED

EWERS, JOHN C. *The case for Blackfoot pottery.* Amer. Anthropol., n.s., 47 (2): 289-298. 1945.

HOLMES, W. H. *Aboriginal pottery of the eastern United States.* 20th Ann. Rep. Bur. Amer. Ethnol. 1903.

MULLOY, WILLIAM. *The Hagen site, a prehistoric village on the lower Yellowstone.* Univ. Montana Publ. Soc. Sci. no. 1. 1942.

———. *An Indian village in the Little Cayuse Mountains of Montana.* Pap. Michigan Acad. Sci., Arts, and Letters 30: 511-521. 1945.

NELSON, N. C. *Camping on ancient trails.* Nat. Hist. 49 (5): 262-267. 1942.

———. *Contribution to Montana archeology.* Amer. Antiqu. 9 (2): 162-169. 1943.

BOTANY.—*A new species of Portulaca from Okinawa.*<sup>1</sup> EGBERT H. WALKER, U. S. National Museum, and SHINJUN TAWADA, Ryukyu Forestry Agency, Okinawa.

The junior author sent the annotated specimen, upon which this new species is based, along with miscellaneous collections from Okinawa Island, to the U. S. National Museum. He reports having first observed it 20 years ago at Zanpea-misaki (cape), Nakagami-gun, Okinawa Island, although the type is from near the village of Onna in Kunigami-gun, Okinawa Island. Search of the literature and comparison with available material indicates it probably represents an undescribed species. In view of the somewhat confused status of the recent literature on Japanese botany, the presentation of a new species from this area is somewhat hazardous.

According to the characterization of *Portulaca* in von Poellnitz's monograph,<sup>2</sup> this species seems to belong in the subgenus *Euportulaca* Speg., section *Rotundatae* von Poelln., subsection *Foveolatae* von Poelln. In habit, it resembles the widespread species *P. quadrifida* L., differing most significantly in the absence of axillary hairs. In this same respect, it differs from the two eastern Asiatic species, *P. insularis* Hosokawa<sup>3</sup> and *P. boninensis* Tuyama,<sup>4</sup> which have been published since von Poellnitz's monograph

<sup>1</sup> Published by permission of the Secretary of the Smithsonian Institution.

<sup>2</sup> POELLNITZ, K. von. *Versuch einer Monographie der Gattung Portulaca L.* Repert. Sp. Nov. Fedde 37: 240-320. 1934.

<sup>3</sup> Trans. Nat. Hist. Soc. Formosa 22: 229. 1934.

<sup>4</sup> Bot. Mag. Tokyo 53: 6. 1939.

was issued. Its perennial caespitose habit, small leaves, absence of axial hairs, so characteristic of many species, and its foveolate sculptured seeds are the outstanding characteristics of this species.

*Portulaca okinawensis* Walker & Tawada, sp. nov.

Planta perennis caespitosa 5-10 cm alta, caulis herbaceis numerosis viridibus implicatis ramosis e caule brevi lignoso griseo orientibus; radicibus non visis; foliis ramulorum apices versus plerumque enatis, subsessilibus vel petiolatis, alternatis vel sub flore vel fructu solitario terminali verticillatis; laminis foliorum in vivo crassis carnis in sicco dense granulosis elliptico-ovatis vel oblongis, 2-4 mm longis, basi obtusis, apice obtusis vel rotundatis, margine integris; foliis involueralibus non carinatis; pilis axillaribus nullis; floribus solitariis terminalibus circiter 1.6 mm diametro, petalis 6, aurantio-flavis vel rubescentibus, staminibus circiter 25, liberis, pistillo solitario vix inferiore, stylo gracili superne paulo dilatato, stigmatibus 4-partito; fructu globoso 2-3 mm diametro nitido horizontaliter dehiscente, cupulae basalis seminiferae margine plus minusve incrassato, semine minuto atro nitido foveolis numerosis non profundis facie ornato.

Nom Jap. Okinawa-matsube-botan (ex Tawada).

Type in the U. S. National Herbarium, no. 1992668, collected October 2, 1949, by Shinjun Tawada (no. 2221) on an exposed rock at the seaside, 20 feet elevation, at Onna, Kunigami-gun, Okinawa Island, in the Ryukyu Islands.

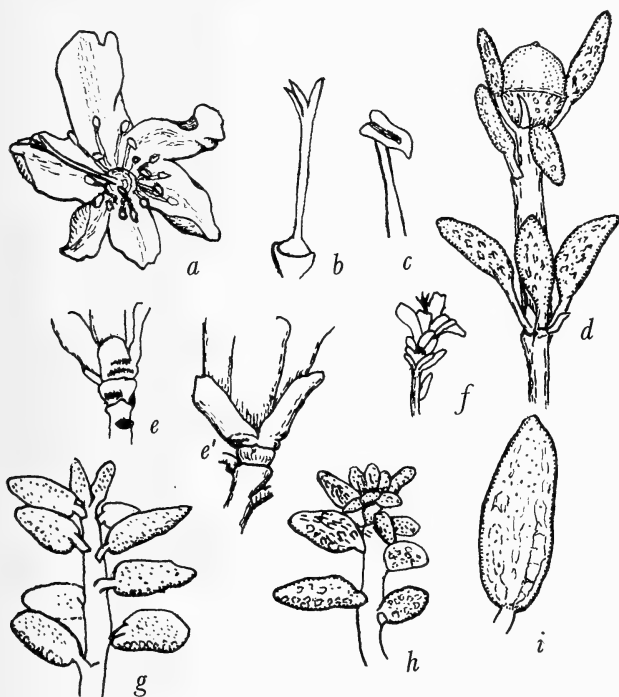

FIG. 1.—*Portulaca okinawensis* Walker & Tawada, sp. nov.: a, Flower; b, pistil; c, stamen; d, fruiting stem tip; e, e', flowering stem tip showing reddish bases of bracts; f, flowering stem; g, vegetative stem, lower side; h, vegetative stem, upper side; i, enlarged leaf, showing greenish intermittent net forming margins to translucent center. Drawing by Tawada.

ENTOMOLOGY.—*New species of Gelechiidae from Argentina (Lepidoptera)*. J. F. GATES CLARKE, Bureau of Entomology and Plant Quarantine.

The following species of Gelechiidae are described from material submitted by Fernando Bourquin and J. A. Pastrana, of Buenos Aires. Two species were reared by Mr. Bourquin and one by Mr. Pastrana from larvae they collected. Figures of the moths and life history notes will be published by Mr. Bourquin.

*Parastega hemisigna*, n. sp.

Fig. 1

Alar expanse, 16 mm.

Labial palpus, antenna, head, thorax, tegula, and ground color of forewing dark, shining purplish-fuscous. Brush of second segment gray and extreme apex of third segment creamy white. From costa of forewing, at one-fifth, a white bar extends to fold, then is continued along the fold to tornus as a narrow tawny line; extreme base of wing and an elongate patch beyond the white bar, black; costal edge, beyond white bar, and cilia, sooty. Hind wing gray; cilia fuscous. Forelegs and midlegs dark purplish fuscous with narrow white annulations on tarsi; hind leg sooty with narrow white annulations on tibia and tarsus. Abdomen shining blackish fuscous; anal tuft sordid ocherous-white with dull fuscous scales mixed ventrally.

*Male genitalia*.—As figured.

*Female genitalia*.—Unknown.

*Type*.—U.S.N.M. no. 60941.

*Remarks*.—Described from the type male dated, "VI. 50" and reared by Fernando Bourquin.

Similar in size to the Central American *P. chionostigma* (Walsingham) and *P. niveisignella* (Zeller) but distinguished from the former by the dark head and palpus and from the latter by the absence of the brownish scaling of forewing.

I have figured (Figs. 2, 2a) the uncus, gnathos, and right harpe of the type of the genus (*niveisignella*) for comparison.

Mr. Bourquin has two additional specimens of *hemisigna* and writes that "the male has two white stripes and the female one white stripe."

*Aristotelia perplexa*, n. sp.

Figs. 3-3a, 4

Alar expanse, 10-12 mm.

Labial palpus whitish, pink tinged; second seg-

ment with brownish-ocherous median and subapical bands; third segment with broad fuscous submedian and subapical bands. Antenna fuscous narrowly banded with white except dorsally the bands not forming complete rings. Head, thorax, tegula, and base of forewing brownish ocherous. Ground color of forewing sordid whitish, the scales tipped with fuscous; basal patch broadly edged with dark brown outwardly; from basal third of costa a dark brown oblique band extends to slightly beyond fold and beyond this, in cell, is a small fuscous spot followed by another at the end of cell; outer half of wing overlaid with brownish ocherous; apical half of costa and termen edged with fuscous, the line broken by a series of pale carmine spots; cilia light brownish ocherous with subterminal and subbasal fuscous bands and base pale carmine; underside fuscous. Hindwing fuscous; cilia slightly paler; from costa of male extends a thick brownish-ocherous hair-pencil. Legs shining ocherous-white variously overlaid and banded with fuscous; foretibia and midtibia and tarsi and posterior tibia alternately banded with pale carmine. Abdomen fuscous above and ocherous-white beneath.

*Male genitalia*.—As figured.

*Female genitalia*.—Genital plate and ostium as figured; signum absent.

*Type*.—U.S.N.M. no. 60942.

*Type locality*.—Tigre, Argentina.

*Remarks*.—Described from the type male and five male and two female paratypes, all from the same locality. The dates on the type series are from March to April 1939. Paratypes in U. S. National Museum and Mr. Bourquin's collection, Buenos Aires.

This species is similar to *A. cynthia* Meyrick and possesses the hair-pencil from costa of hind wing of male; but *cynthia* lacks the carmine coloring of *perplexa*. The cucullus of *cynthia* is greatly elongated and sharply curved ventrad, while that of *perplexa* is short and dilated.

*Aristotelia parephoria*, n. sp.

Figs. 5-5a, 6-6a

Alar expanse, 11-14 mm.

Labial palpus sordid white; second segment with three bands and apex light brown; third segment with basal and median bands light brown and subapical annulation blackish fuscous. Head

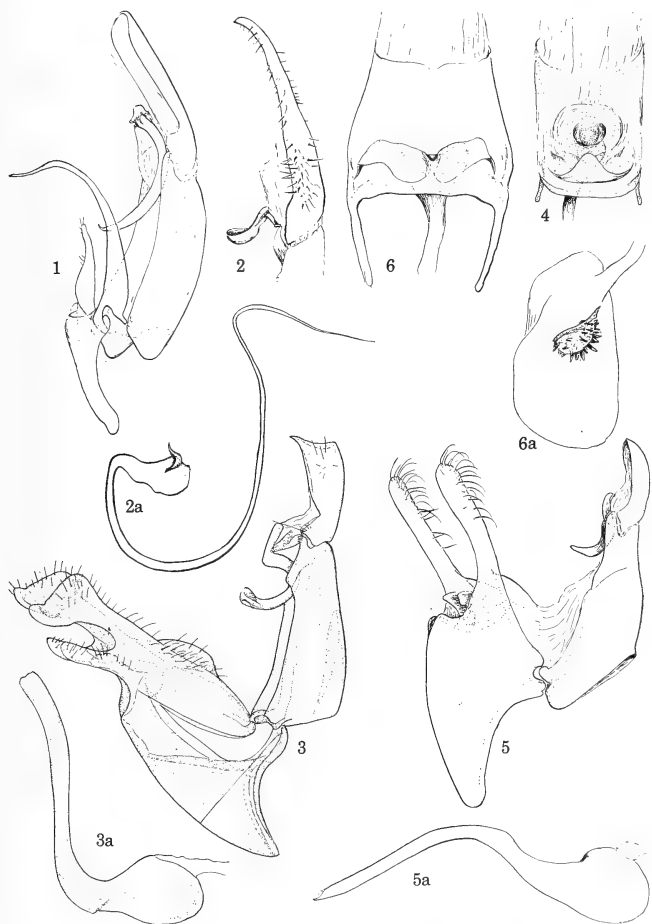

FIGS. 1-6a.—1, *Parastega hemisigna*, n. sp.: Lateral aspect of male genitalia with aedeagus removed. 2-2a, *Parastega niveisignella* (Zeller): 2, Lateral aspect of uncus and gnathos; 2a, right harpe. 3-3a, *Arsitotelia perplexa*, n. sp.: 3, Lateral aspect of male genitalia with aedeagus removed; 3a, aedeagus. 4, *Arsitotelia perplexa*, n. sp.: Detail of genital plate and ostium. 5-5a, *Arsitotelia paeophoria*, n. sp.: 5, Lateral aspect of male genitalia with aedeagus removed; 5a, aedeagus. 6-6a, *Arsitotelia paeophoria*, n. sp.: 6, Detail of genital plate and ostium; 6a, bursa copulatrix and signum.

pale brownish ochereous with a dorsal fuscous stripe. Thorax, tegula, and ground color of forewing ochereous-white; thorax and tegula strongly suffused with fuscous anteriorly; dorsal half and apex of forewing overlaid with buff; from base of costa, and from costa at one-third, blackish-fuscous bands extend to fold, the latter band, outwardly curved, joins narrowly a fuscous shade at outer third of costa; apex and tornus each with a small fuscous shade extended into the otherwise buff cilia; underside of forewing blackish fuscous. Hind wing and cilia fuscous; costal third of underside of hind wing blackish fuscous, remainder ochereous-white. Legs shining ochereous-white; tibiae and tarsi banded with blackish fuscous, abdomen grayish above, ochereous-white beneath.

**MALACOLOGY.**—Recent species of the *cyrenoid pelecypod* *Glossus*.<sup>1</sup> DAVID NICOL, U. S. National Museum.

The study on *Glossus* is the fourth of a series on relict pelecypod genera. Lamy (1920, pp. 290–296) has done the most recent thorough work on the genus.

*Glossus* is represented by one species living in western European seas and the Mediterranean. The Indo-Pacific species allocated to *Meiocardia* have entirely different geographical distributions and certainly should be considered as a distinct genus on the basis of shell morphology. The exact relationship between *Glossus* and *Meiocardia* has never been shown, although Dall (1900, pp. 1065, 1066) claimed that the fossil and living species of the two groups are difficult to separate. Dall, Bartsch, and Rehder (1938, p. 121) consider *Glossus* and *Meiocardia* as distinct genera.

The torsion of the beaks has so greatly modified the hinge of the glossids that it is difficult to allocate the family to any higher taxonomic category, and it is not certain that any of the Mesozoic species of glossoid-form pelecypods can be placed in the genus *Glossus*. (See Stoliczka, 1871, p. 188.) Despite the great amount of torsion in *Glossus*, however, the genus bears much superficial resemblance to *Arctica*. This resemblance would be even more striking if the hinge of *Arctica* were twisted to the same degree that it is in *Glossus*.

<sup>1</sup> Published by permission of the Secretary of the Smithsonian Institution.

*Male genitalia*.—As figured.

*Female genitalia*.—Genital plate, ostium, and signum as figured.

*Type*.—U.S.N.M. no. 60943.

*Type locality*.—Tucumán, Argentina.

*Remarks*.—Described from the type male and two male and four female paratypes, all from the type locality. The dates are "VIII, 1939," and the specimens were collected by J. A. Pastrana. Paratypes in U. S. National Museum and Mr. Pastrana's collection, Buenos Aires.

*A. parephoria* appears to be nearest to *A. ephoria* Meyrick but differs from that species by the long terminal segment of palpus and the three dark bands on second segment.

From the Paleocene through the Miocene, the genus *Glossus* has apparently been confined to temperate seas in the northern hemisphere except for the northern Pacific region. From the Pliocene to the Recent, the genus has been confined to western Europe and the Mediterranean Sea.

Family GLOSSIDÆ Stoliczka, 1871

Genus *Glossus* Poli, 1795

*Cardium* Linné, 1758 (in part).  
*Chama* Linné, 1764 (in part).  
*Chama* Linné, 1767 (in part).  
*Cardita* Bruguière, 1792 (in part).  
*Glossoderma* Poli, 1795.  
*Isocardia* Lamarck, 1799.  
*Buccardium* Megerle von Mühlfeld, 1811.  
*Bucardia* Schumacher, 1817.  
*Tychocardia* Römer, 1869.

Genotype: (Monotypy) *Glossus rubicundus* Poli, 1795 = *Chama cor* Linné, 1767 = *Cardium humanum* Linné, 1758.

There appears to be no nomenclatorial reason why Poli's names can not be used despite the fact that he employed two generic names, one for the soft parts of the mollusk and the other for the shell. The shell name always ends in "derma," and *Cerastoderma* has been used consistently for a genus of cardiids. *Glossus* and *Glossoderma* are absolute synonyms, but *Glossus* is to be preferred on the basis of page priority. *Glossus* Poli, 1795, is clearly prior to *Isocardia* Lamarck, 1799, and on that basis must be employed for *Cardium humanum* Linné.

*Glossus humanus* (Linné), 1758

Figs. 2-5

- 1758. *Cardium humanum* Linné, Syst. Nat., ed. 10: 682.
- 1764. *Chama cordiformis* Linné, Mus. Lud. Ul. Reg.: 516.
- 1767. *Chama cor* Linné, Syst. Nat., ed. 12, 1 (pt. 2): 1137.

- 1792. *Cardita cor* (Linné), Bruguière, Encyc. Meth., Nat. Hist. Vers, 1: 403, 404; 1797, *Cardita*, pt. 19, no. 18: pl. 232, figs. la-d.
- 1795. *Glossus rubicundus* Poli, Test. utr. Siciliae 2: 114, 253, pl. 15, figs. 30, 34, 35, 36; pl. 23, figs. 1, 2.
- 1795. *Glossoderma rubicundus* Poli, Test. utr. Siciliae 2: 253.
- 1795. *Glossoderma cor* (Linné), Poli, Test. utr. Siciliae 2: 259.

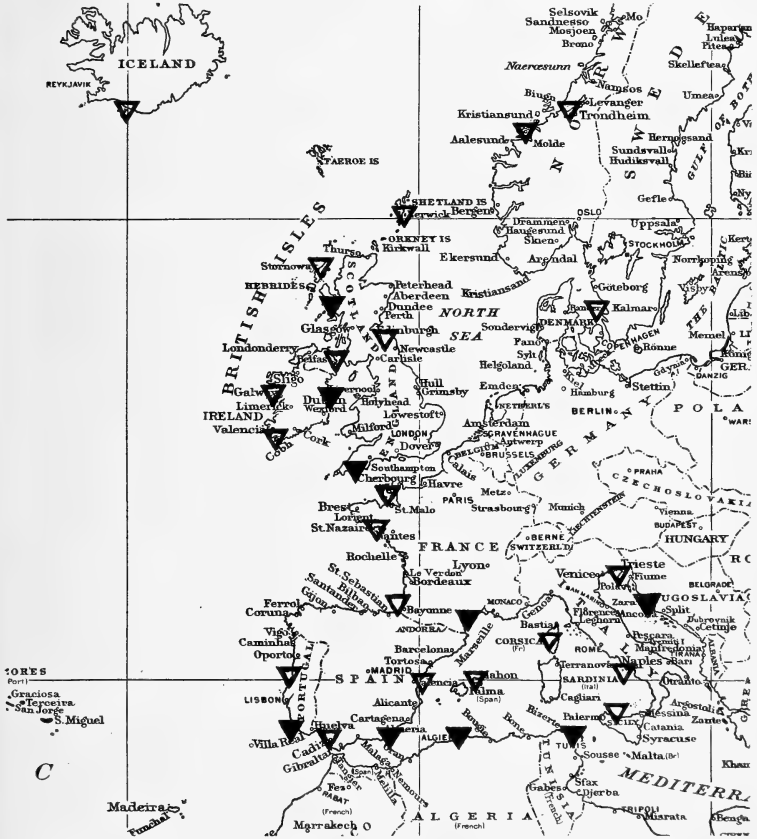

FIG. 1.—Distribution of living specimens of *Glossus humanus* (Linné): ▼, Locality data based on U. S. National Museum specimens; ▽, locality data based on specimens in other museums and on published records.

1798. *Cardium cor auritum* Röding, *Muc. Bolt.*: 192, no. 415.
1799. *Isocardia cor* (Linné), Lamarek, *Mem. Soc. Hist. Nat. Paris* 1: 86.
1801. *Isocardia globosa* Lamarek, *Syst. animaux sans vert.*, etc., 1: 118.
1811. *Buccardium commune* Megerle von Mühlfeld, *Mag. Ges. Nat. Freunde Berlin* 5 (1), art. 2: 52.
1815. *Glossus cor* (Linné), Oken, *Lehr. Nat.*, Teil 3, *Zool.*: 235.
1817. *Buccardia communis* (Megerle von Mühlfeld), Schumacher, *Essai nouv. syst.*, etc.: 144, pl. 13, figs. 2a, b.
1845. *Isocardia hibernica* Reeve, *Conch. Icon.* 2, *Isocardia*: pl. 1, sp. 4.
1853. *Cardia humana* (Linné), Mörch, *Cat. Conch. Yoldi* 2: 38.
1855. *Isocardia cor* var. *hibernica* Reeve, *Hanley, Ipsa Linnaei Conchylia*: 84.
1858. *Buccardia cor* (Linné), H. and A. Adams, *Gen. Rec. Moll.* 2: 461, pl. 112, figs. 5a, b.
1869. *Isocardia (Tychocardia) cor* (Linné), Römer, in *Martini und Chemnitz, Conch.-Cab.*, ed. 2, 10 (2), *Cardiacea*: 5-7, pl. 1, figs. 1-3.
1900. *Isocardia humana* (Linné), Dall, *Tert. fauna Florida* 3 (pt. 5): 1064.
1903. *Isocardia cor* var. *valentiana* Pallary, *Ann. Mus. Hist. Nat. Marseille, Zool.*, 8, *mém.* 1: 15, pl. 1, fig. 13.
1937. *Glossus humanus* (Linné), van Regteren Altena, *Bijdrage tot de kennis der fossiele, subfossiele en Recente Mollusken*, etc.: 70, 71.

*Description.*—Shell porcellaneous, thin, exterior ornamented only by growth lines; small specimens often have two small folds separated by incised lines extending from the ligament obliquely downward toward the posteroventral margin; a poorly defined, broad depressed area in front of beaks, better defined in small specimens and often delimited by two incised lines; periostracum dark reddish brown to black on large specimens, lighter on small specimens, attaining a light greenish yellow on smallest specimens; periostracum nearly smooth in appearance on large specimens; on small ones fine, closely spaced, radiating lines composed of darker-colored ridges of periostracum; valves without gape, equi-valve; interior ventral margin smooth; beaks spirally enrolled and strongly prosogyrate, umbones swollen; ligament external, weak, parivincular, split into two parts anteriorly and dragged under spirally enrolled beaks, opisthodontic; hinge teeth cyrenoid, hinge formula  $\frac{3a, 1, 3b, PI}{2a, 2b, 4b, PII}$ , all teeth laminar and nearly horizontal, 2a and 2b in left valve almost completely fused, 1 and 3b in right valve somewhat fused; pallial line integripalliate, ante-

rior adductor muscle scar deeper and better marked but smaller than posterior adductor muscle scar.

*Measurements in mm.*—Only specimens with both valves were measured:

U.S.N.M. no.	Length	Height	Convexity (both valves)
201293	104.2	98.3	83.2
201292	100.8	95.4	88.4
131658	93.0	89.2	77.7
304722	83.7	74.7	65.5
201294	81.7	79.6	59.0
201299	81.2	80.0	60.0
186122	79.3	74.7	69.5
201295	75.1	75.6	59.1
201302	70.3	64.1	59.7
304782	69.6	65.1	59.0
201298	67.8	66.1	61.3
201298a	60.4	59.6	53.2
201296	52.6	55.8	40.3
201300	45.9	48.8	36.2
201294a	45.6	48.2	35.7
131658a	45.6	45.6	38.6
201296a	44.1	48.0	34.4
201297	38.9	43.0	29.0
201297a	32.8	35.0	24.3
201337	26.8	27.7	20.5

One trend is quite apparent from the measurements: small shells are longer than they are high, whereas large shells are higher than they are long. The ratio of convexity to height was computed. All seven shells from the Mediterranean Sea had ratios ranging from 0.90 to 0.84. The ratios of 12 shells from the British Isles ranged from 0.80 to 0.72 except for one large shell from Dublin Bay which had a ratio of convexity to height of 0.88. Reeve (1845, vol. 2, p. 2, *Isocardia*) claimed that the specimens from Ireland were less globose than those from the Mediterranean Sea. On the basis of this difference and some other minor features, he proposed the new species name *hibernica* for the Irish specimens. To my knowledge no other conchologist has considered *hibernica* a distinct species, but Reeve's contention that the Mediterranean specimens are more globose is borne out by the few specimens I have measured.

*Number of specimens.*—There are 32 specimens of *Glossus humanus* in the collection of the United States National Museum.

*Locality data.*—The following localities are represented by specimens in the National Museum: Zara, Yugoslavia; Tunis; Cete, France; Algiers; Cape de Gata, Spain; Cape Sagres, Portugal; Falmouth, England; Plymouth, England; Dublin Bay; Isle of Man; Oban, Scotland; Hebrides; Shetland Islands.



GEOGRAPHICAL DISTRIBUTION AND ECOLOGY  
OF *GLOSSUS HUMANUS* (LINNÉ)

This study is encumbered by two difficulties. *Glossus humanus* is not a common species, except for a few scattered localities, and observations on its habitat are meager. The more serious difficulty results from an error by J. Gwyn Jeffreys, who mistook species of *Kelliella* for the young of *Glossus*. Some of the Jeffreys' material collected on the *Porcupine* and *Valorous* expeditions is in the National Museum collection. Specimens identified as "*Isocardia cor*" by Jeffreys are not that species, a point upheld by Sars and much later by other conchologists.

The exact northern limit of distribution of *Glossus* is worthy of much additional investigation. Only one living specimen of *Glossus humanus* has been found off the southern coast of Iceland thus far (Madsen, 1949, p.

49), although the molluscan fauna of the island has been extensively collected and studied. The genus has not been reported from the Faroes. The report of *Glossus* from the Lofoten Islands off the coast of Norway was based on a misidentification by Jeffreys. The genus is rare from Trondhjem Fjord southward and eastward into the Kattegat. *Glossus* is fairly common in certain places along the coasts of the British Isles and is also found in the Shetlands. It has been reported all along the coasts of France, Portugal, and Spain. In the Mediterranean, *Glossus* is frequently found as far east as the Adriatic Sea. The fact that it has not been found east of there may be due to lack of careful collecting. It apparently is not present on the west coast of Africa, even near the entrance to the Mediterranean Sea. Jeffreys has reported *Glossus* from the Azores, but this report is

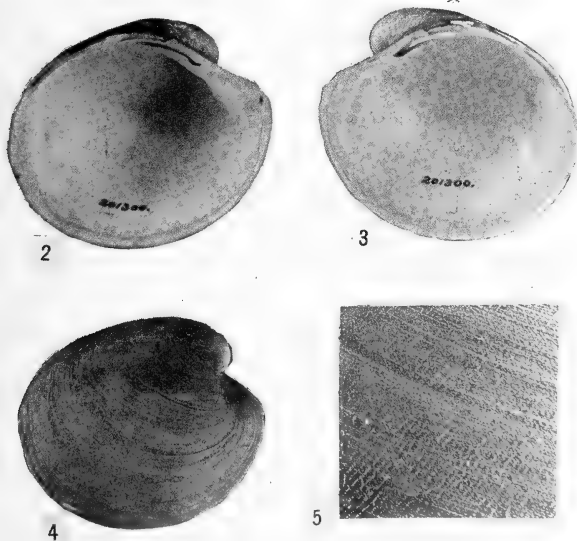

FIGS. 2-5.—*Glossus humanus* (Linné): 2, Interior of left valve,  $\times 1$ ; 3, interior of right valve,  $\times 1$ ; 4, exterior of right valve,  $\times 1$ ; 5, enlarged portion of exterior surface of shell showing fine radial ridges of periostracum,  $\times 6$ . (All figures are of a young specimen from Falmouth, England; U.S.N.M. no. 201300.)

thought to be based on a misidentification. Further collecting will no doubt more accurately delimit the distribution of the genus.

Additional ecological data are greatly needed on *Glossus humanus*. The species apparently is found on sand, sandy-mud, or mud bottoms. It has been thought by some to have a wide bathymetric range, but this idea is now believed to be incorrect. Jeffreys has reported *Glossus* from more than 2,000 meters of water, but the specimens found at that depth are probably all *Kelliella*. *Glossus* apparently is found in depths ranging from about 5 to 150 meters. The probable temperature of the bottom where the genus thrives ranges from 8° to 15°C.

*Acknowledgments.*—The following persons gave me data on geographical distribution of specimens of *Glossus*: William J. Clench, Museum of Comparative Zoology at Harvard College; Leo G. Hertlein, California

Academy of Sciences; A. Myra Keen, Stanford University. I am greatly indebted to them for their assistance.

#### REFERENCES

- DALL, W. H. *Contributions to the Tertiary fauna of Florida, etc.* Trans. Wagner Free Inst. Sci. 3 (pt. 5): 949-1218, pls. 36-47. 1900.
- DALL, W. H., BARTSCH, P., and REHDER, H. A. *A manual of the Recent and fossil marine pelecypod mollusks of the Hawaiian Islands.* Bernice P. Bishop Mus. Bull. 153: 233 pp., 28 figs., 58 pls., 1938.
- LAMY, E., *Révision des Cypricardiacea et des Isocardiaacea vivants du Muséum d'Histoire Naturelle de Paris.* Journ. Conchyl. 64 (4): 259-307. 1920.
- MADSEN, F. J. *The zoology of Iceland* 4 (pt. 63, Marine Bivalvia): 116 pp., 12 figs. 1949.
- REEVE, L. A. *Conchologia iconica* 2, *Isocardia*: 2 pp., 1 pl., 1845.
- STOLICZKA, F. *Cretaceous fauna of southern India* 3, *The Pelecypoda, etc.* Palaeontologica Indica (Geological Survey of India memoirs): 537 pp., 50 pls. 1871.

**MALACOLOGY.**—*More new urocoptid mollusks from Mexico.* PAUL BARTSCH, U. S. National Museum.

To the indefatigable efforts and the stimulating influence that Miss Marie Bourgeois, of Mixcoac, exerted upon her friends to help make known the molluscan fauna of Mexico, the U. S. National Museum is indebted for the following new species of urocoptid land snails transmitted to us for report.

***Coelostemma anconai*, n. sp.**

Figs. 1, 3

Shell cylindroconic, pale horn-colored when living, dead shells white. The nucleus consists of about two turns, which are somewhat inflated and strongly rounded and form a slightly bulbous apex. The nuclear turns are finely granulose. The first seven postnuclear whorls increase gradually in width, rendering this part of the shell elongate-conic. Beginning with the eighth turn the shell becomes cylindrical in form, contracting slightly on the last three whorls. The postnuclear whorls are slightly rounded and separated by a moderately impressed suture. They are marked by decidedly retractively curved axial riblets, which are slightly less strongly developed on the cylindrical portion of the shell than on the two ends. Of these riblets about 40 are present on the second postnuclear turn, 80 on the tenth, and 62 on the

penultimate whorl. On the last turn behind the peristome the riblets become fine, hairlike, and crowded. The spaces separating the riblets average about double the width of the ribs. The last turn is solute for about one-fifth of a turn, the solute portion bearing the rib sculpture of the rest of this portion of the shell. The aperture is subcircular and is somewhat sinuous on the parietal wall where the peristome is a little less expanded than on the rest of the aperture where it widens in a gentle curve. The columella is hollow, broad, about one-third the width of the shell, and shows fine axial markings; it gradually narrows in the last two turns.

The holotype, U.S.N.M. no. 595018, has 19 whorls and measures: Length 26 mm; diameter of the cylindrical portion 6 mm. U.S.N.M. no. 595019 comprises the paratype, of which we have figured the columella and some fragments.

We are naming the species for Prof. I. Ancona, who collected the specimens at Ixcatopan, Guerrero, Mexico.

Of the known species of *Coelostemma* this species resembles most nearly *C. igualaensis* Bartsch, from Iguala, Guerrero, Mexico, from which it is easily distinguished by its smaller size, more cylindrical outline, narrower shell, and stronger ribbing.

*Holospira wilmoti*, n. sp.

Fig. 2

Shell cylindroconic, white with the interior of the aperture pale chestnut-brown. The nucleus consists of about  $2\frac{1}{2}$  strongly rounded whorls that form a mucronate apex. The first four post-nuclear whorls increase rapidly in width, while the succeeding turns are cylindrical, contracting again toward the base. The postnuclear whorls are flattened and separated by a slightly impressed suture. On the conic portion feeble decidedly retractively curved axial riblets are indicated, while on the cylindrical portion the axial markings are reduced to mere lines of growth. The last whorl and a little of the penultimate turn bear distantly spaced somewhat sinuous axial ribs, which extend undiminished over the slightly angulated periphery and the base into the umbilical chink. These ribs are about one-third as wide as the spaces that separate them. The last whorl is solute for about one-eighth of a turn. Aperture obliquely pear-shaped; peristome broadly flatly expanded and thickened. Columella hollow, about one-fourth the diameter of the whorls, bearing a feeble obsolete fold in the cylindrical portion of the shell which expands into a thin slightly curved blade in the penultimate whorl, where it extends over three-fifths of the width of the chamber bending slightly upward toward the parietal fold. In the last turn the columellar fold becomes much reduced and thickened, being scarcely noticeable in the aperture. The parietal fold is well developed and is confined to the penultimate turn. The basal fold in the same turn is poorly developed, while the labial fold is about one-half as strong as the parietal fold.

The type, U.S.N.M. no. 595020, was collected by George Wilmot on Cerro del Fraile, near Villa García, Nuevo León, Mexico. It has 14 whorls and measures: Length 20 mm; diameter of cylindrical portion 7 mm.

This species most nearly resembles *H. orcutti* Bartsch, which Orcutt collected on a limestone

paredon in Coahuila, Mexico. Its much smaller size and more cylindrical form readily distinguish it.

We take pleasure in naming it for its discoverer.

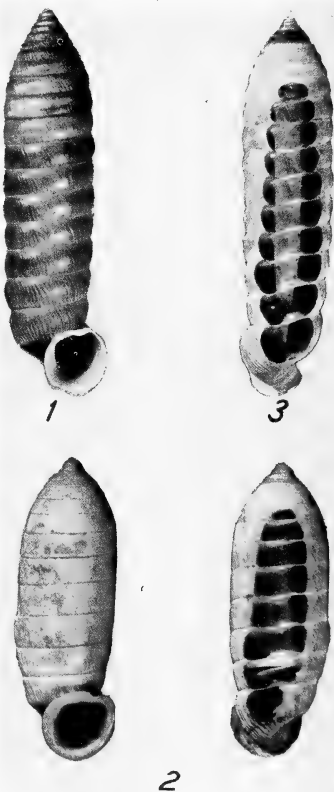

FIGS. 1-3.—1, 3, *Coelostenma anconai*, n. sp.;  
2, *Holospira wilmoti*, n. sp.

## PROCEEDINGS OF THE ACADEMY

## 444TH MEETING OF BOARD OF MANAGERS

The 444th meeting of the Board of Managers, held in the Cosmos Club on February 12, 1951, was called to order at 8:05 P.M. by the President, NATHAN R. SMITH. Also present were: W. RAMBERG, H. S. RAPPELLE, J. A. STEVENSON, C. DRECHSLER, A. T. MCPHERSON, W. R. WEDEL, J. J. FAHEY, E. H. WALKER, W. A. DAYTON, R. S. DILL, L. A. SPINDLER, A. M. GRIFFIN, F. M. DEFANDORF, and, by invitation, MARGARET PITTMAN, G. P. WALTON, and L. E. YOCUM.

The President announced the following appointments:

*Appointed Members of Executive Committee:* W. Ramberg, H. S. Rappleye, J. A. Stevenson, and F. M. Defandorf.

*Board of Editors of the Journal:* Charles Drechsler, to replace Frederick J. Hermann, designated Senior Editor. J. P. E. Morrison to replace F. C. Kracek. T. P. Thayer (Geology) was appointed an Associate Editor for a term of two years; R. K. Cook (physics and mathematics), F. A. Chace (biology), and M. L. Bomhard (botany) were appointed Associate Editors for a term of 3 years.

*Committee on Membership:* L. A. Spindler (Chairman), M. S. Anderson, Merrill Bernard, R. E. Blackwelder, R. C. Duncan, George T. Faust, Ira B. Hansen, D. Breesee Jones, Dorothy Nickerson, Francis A. Smith, Heinz Specht, Alfred Weisser.

*Committee on Meetings:* Margaret Pittman (Chairman), Norman Bekkedahl, W. R. Chapline, Dorland J. Davis, F. B. Scheetz, Henry W. Wells.

*Committee on Monographs:* J. R. Swallen (Chairman). To January 1954: S. F. Blake, F. C. Kracek.

*Committee on Awards for Scientific Achievement:* George P. Walton, General Chairman. *For the Biological Sciences:* G. H. Coons (Chairman), J. E. Faber, Jr., Myrna F. Jones, F. W. Poos, J. R. Swallen. *For the Engineering Sciences:* R. S. Dill (Chairman), Arsham Amirikian, J. W. McBurney, Frank Neumann, A. H. Scott. *For the Physical Sciences:* G. P. Walton (Chairman), F. S. Brackett, G. E. Holm, C. J. Humphreys, J. Howard McMillen. *For Teaching of Science:* B. D. Van Evera (Chairman), R. P. Barnes, F. E. Fox, T. Koppanyi, M. H. Martin, A. T. McPherson.

*Committee on Grants-in-Aid for Research:* L. E. Yocum (Chairman). M. X. Sullivan, H. L. Whittemore.

*Committee on Policy and Planning:* J. I. Hoffman (Chairman). To January 1954: Henry B. Collins, Jr., W. W. Rubey.

*Committee on Encouragement of Science Talent:* M. A. Mason (Chairman). To January 1954: J. M. Caldwell, Waldo L. Schmitt.

*Representative on Council of A.A.A.S.:* F. M. Setzler.

*Committee of Auditors:* J. H. Martin (Chairman), N. F. Braaten, W. J. Youden.

*Committee of Tellers:* W. G. Brombacher (Chairman), A. R. Merz, Louise M. Russell.

The Secretary reported a meeting of the Executive Committee at 6:30 P.M., February 12, 1951, at the Cosmos Club with the following members in attendance: N. R. SMITH, W. RAMBERG, H. S. RAPPELLE, J. A. STEVENSON, and F. M. DEFANDORF. At this meeting the budget presented by the Treasurer for 1951 was discussed in some detail and approved for submission to the Board of Managers.

The following budget was presented to the Board, discussed by the Treasurer, and adopted by the Board without change:

	RECEIPTS		
	1950	Estimated 1951	1951 Budget
Dues.....	\$3985.00	\$4200.00	
Journal Subscriptions.....	1339.50	1600.00	
Interest & Dividends.....	1521.50	1950.00	
Sales.....	93.43	100.00	
	\$6939.43	\$7850.00	
DISBURSEMENTS			
Journal & Journal Office.....	\$6435.74	\$6500.00	\$6500.00
Secretary's office.....	481.26	550.00	550.00
Treasurer's office.....	304.59	300.00	300.00
S. M. & C. of Publications.....	30.67	50.00	50.00
Meetings Committee.....	244.30	500.00	500.00
Membership Committee.....	1.50	20.00	20.00
Science Fair.....	100.00	100.00	100.00
Sciences Calendar.....	10.00	50.00	50.00
Archivist.....	—	75.00	75.00
	\$7608.06	\$8145.00	\$8145.00
Estimated Deficit.....			\$ 295.00

A letter from J. A. Stevenson was read in which he submitted his resignation as an Elected Member of the Board of Managers because he is at present Archivist of the Academy. The Board accepted the resignation and in Mr. Stevenson's place appointed Milton Harris.

The Board appointed C. F. W. Muesebeck to fill the vacancy created by the resignation of H. P. Bars as an Elected Member of the Board of Managers.

The meeting adjourned at 8:55 P.M.

F. M. DEFANDORF, Secretary

## Officers of the Washington Academy of Sciences

<i>President</i> .....	NATHAN R. SMITH, Plant Industry Station
<i>President-elect</i> .....	WALTER RAMBERG, National Bureau of Standards
<i>Secretary</i> .....	F. M. DEFANDORF, National Bureau of Standards
<i>Treasurer</i> .....	HOWARD S. RAPPELVE, U. S. Coast and Geodetic Survey
<i>Archivist</i> .....	JOHN A. STEVENSON, Plant Industry Station
<i>Custodian and Subscription Manager of Publications</i>	HARALD A. REHDER, U. S. National Museum

### *Vice-presidents Representing the Affiliated Societies:*

Philosophical Society of Washington.....	EDWARD U. CONDON
Anthropological Society of Washington.....	WALDO R. WEDEL
Biological Society of Washington.....	
Chemical Society of Washington.....	JOSEPH J. FAHEY
Entomological Society of Washington.....	FREDERICK W. POOS
National Geographic Society.....	ALEXANDER WETMORE
Geological Society of Washington.....	LEASON H. ADAMS
Medical Society of the District of Columbia.....	
Columbia Historical Society.....	GILBERT GROSVENOR
Botanical Society of Washington.....	E. H. WALKER
Washington Section, Society of American Foresters.....	WILLIAM A. DAYTON
Washington Society of Engineers.....	CLIFFORD A. BETTS
Washington Section, American Institute of Electrical Engineers	FRANCIS M. DEFANDORF

Washington Section, American Society of Mechanical Engineers.....	RICHARD S. DILL
Helminthological Society of Washington.....	L. A. SPINDLER
Washington Branch, Society of American Bacteriologists.....	ANGUS M. GRIFFIN
Washington Post, Society of American Military Engineers.....	HENRY W. HEMPLE
Washington Section, Institute of Radio Engineers.....	HERBERT G. DORSEY
District of Columbia Section, American Society of Civil Engineers.....	

### *Elected Members of the Board of Managers:*

To January 1952.....	W. F. FOSHAG, C. L. GAZIN
To January 1953.....	C. F. W. MUESEBECK*, A. T. MCPHERSON
To January 1954.....	SARA E. BRANHAM, MILTON HARRIS*

*Board of Managers*..... All the above officers plus the Senior Editor

*Board of Editors and Associate Editors*..... [See front cover]

*Executive Committee*..... N. R. SMITH (chairman), WALTER RAMBERG, H. S. RAPPELVE, J. A. STEVENSON, F. M. DEFANDORF

*Committee on Membership*..... L. A. SPINDLER (chairman), M. S. ANDERSON, MERRILL BERNARD, R. E. BLACKWELDER, R. C. DUNCAN, G. T. FAUST, I. B. HANSEN, D. B. JONES, DOROTHY NICKERSON, F. A. SMITH, HEINZ SPECHT, ALFRED WEISSLER

*Committee on Meetings*..... MARGARET PITTMAN (chairman), NORMAN BEKKEDAHL, W. R. CHAPLINE, D. J. DAVIS, F. B. SCHEETZ, H. W. WELLS

### *Committee on Monographs:*

To January 1952.....	J. R. SWALLEN (chairman), PAUL H. OEHSER
To January 1953.....	R. W. IMLAY, P. W. OMAN
To January 1954.....	S. F. BLAKE, F. C. KRACEK

### *Committee on Awards for Scientific Achievement (GEORGE P. WALTON, general chairman):*

For the Biological Sciences..... G. H. COONS (chairman), J. E. FABER, JR., MYRNA F. JONES, F. W. POOS, J. R. SWALLEN

For the Engineering Sciences..... R. S. DILL (chairman), ARSHAM AMIRIKIAN, J. W. MCBURNEY, FRANK NEUMANN, A. H. SCOTT

For the Physical Sciences..... G. P. WALTON (chairman), F. S. BRACKETT, G. E. HOLM, C. J. HUMPHREYS, J. H. McMILLEN

For Teaching of Science..... B. D. VAN EVERA (chairman), R. P. BARNES, F. E. FOX, T. KOPPANYI, M. H. MARTIN, A. T. MCPHERSON

*Committee on Grants-in-aid for Research*..... L. E. YOCUM (chairman), M. X. SULLIVAN, H. L. WHITTEMORE

### *Committee on Policy and Planning:*

To January 1952.....	J. I. HOFFMAN (chairman), M. A. MASON
To January 1953.....	W. A. DAYTON, N. R. SMITH
To January 1954.....	H. B. COLLINS, JR., W. W. RUBEY

### *Committee on Encouragement of Science Talent:*

To January 1952.....	M. A. MASON (chairman), A. T. MCPHERSON
To January 1953.....	A. H. CLARK, F. L. MOHLER
To January 1954.....	J. M. CALDWELL, W. L. SCHMITT

*Representative on Council of A. A. A. S.*..... F. M. SETZLER

*Committee of Auditors*..... J. H. MARTIN (chairman), N. F. BRAATEN, W. J. YOUDEN

*Committee of Tellers*..... W. G. BROMBACHER (chairman), A. R. MERZ, LOUISE M. RUSSELL

\* Appointed by Board to fill vacancy.

## CONTENTS

	Page
MATHEMATICS.—The theory of group representations. FRANCIS E. JOHNSTON.....	117
MATHEMATICS.—On an equation of Neményi and Truesdell. D. S. MITRINOVITCH.....	129
ARCHEOLOGY.—Notes on aboriginal pottery from Montana. WALDO R. WEDEL.....	130
BOTANY.—A new species of <i>Portulaca</i> from Okinawa. EGBERT H. WALKER and SHINJUN TAWADA.....	138
ENTOMOLOGY.—New species of Gelechiidae from Argentina (Lepidoptera). J. F. GATES CLARKE.....	140
MALACOLOGY.—Recent species of the cyrenoid pelecypod <i>Glossus</i> . DAVID NICOL.....	142
MALACOLOGY.—More new urocoptid mollusks from Mexico. PAUL BARTSCH.....	146
PROCEEDINGS: THE ACADEMY.....	148

JOURNAL  
OF THE  
WASHINGTON ACADEMY  
OF SCIENCES

BOARD OF EDITORS

CHARLES DRECHSLER  
PLANT INDUSTRY STATION  
BELTSVILLE, MD.

WILLIAM F. FOSHAG  
U. S. NATIONAL MUSEUM

J. P. E. MORRISON  
U. S. NATIONAL MUSEUM

ASSOCIATE EDITORS

J. C. EWERS  
ANTHROPOLOGY

C. W. SABROSKY  
ENTOMOLOGY

F. A. CHACE, JR.  
BIOLOGY

J. I. HOFFMAN  
CHEMISTRY

T. P. THAYER  
GEOLOGY

MIRIAM L. BOMHARD  
BOTANY

R. K. COOK

PHYSICS AND MATHEMATICS

PUBLISHED MONTHLY

BY THE

WASHINGTON ACADEMY OF SCIENCES

MOUNT ROYAL & GUILFORD AVES.

BALTIMORE, MARYLAND

Entered as second class matter under the Act of August 24, 1912, at Baltimore, Md.  
Acceptance for mailing at a special rate of postage provided for in the Act of February 28, 1925.  
Authorized February 17, 1949

## Journal of the Washington Academy of Sciences

This JOURNAL, the official organ of the Washington Academy of Sciences, publishes: (1) Short original papers, written or communicated by members of the Academy; (2) proceedings and programs of meetings of the Academy and affiliated societies; (3) notes of events connected with the scientific life of Washington. The JOURNAL is issued monthly. Volumes correspond to calendar years.

*Manuscripts* may be sent to any member of the Board of Editors. It is urgently requested that contributors consult the latest numbers of the JOURNAL and conform their manuscripts to the usage found there as regards arrangement of title, subheads, synonyms, footnotes, tables, bibliography, legends for illustrations, and other matter. Manuscripts should be typewritten, double-spaced, on good paper. Footnotes should be numbered serially in pencil and submitted on a separate sheet. The editors do not assume responsibility for the ideas expressed by the author, nor can they undertake to correct other than obvious minor errors.

*Illustrations* in excess of the equivalent (in cost) of one full-page halftone are to be paid for by the author.

*Proof*.—In order to facilitate prompt publication one proof will generally be sent to authors in or near Washington. It is urged that manuscript be submitted in final form; the editors will exercise due care in seeing that copy is followed.

*Unusual cost* of foreign, mathematical, and tabular material, as well as alterations made in the proof by the author, may be charged to the author.

*Author's Reprints*.—Reprints will be furnished in accordance with the following schedule of prices (approximate):

Copies	4 pp.	8 pp.	12 pp.	16 pp.	20 pp.	Covers
100	\$3.25	\$6.50	\$ 9.75	\$13.00	\$16.25	\$3.00
200	6.50	13.00	19.50	26.00	32.50	6.00
300	9.75	19.50	29.25	39.00	48.75	9.00
400	13.00	26.00	39.00	52.00	65.00	12.00

*Subscriptions* or requests for the purchase of back numbers or volumes of the JOURNAL or the PROCEEDINGS should be sent to HARALD A. REHDER, Custodian and Subscription Manager of Publications, U. S. National Museum, Washington 25, D. C.

*Subscription Rates* for the JOURNAL.—Per year..... \$7.50

Price of back numbers and volumes:	Per Vol.	Per Number
Vol. 1 to vol. 10, incl.—not available.*	—	—
Vol. 11 to vol. 15, incl. (21 numbers per vol.)	\$10.00	\$0.70
Vol. 16 to vol. 22, incl. (21 numbers per vol.)	8.00	0.60
Vol. 23 to current vol. (12 numbers per vol.)	7.50	0.90

\* Limited number of complete sets of the JOURNAL (vol. 1 to vol. 40, incl.) available for sale to libraries at \$341.00

MONOGRAPH No. 1, "The Parasitic Cuckoos of Africa," by Herbert Friedmann. \$4.50

PROCEEDINGS, vols. 1-13 (1899-1911) complete..... \$25.00

Single volumes, unbound..... 2.00

Single numbers..... .25

*Missing Numbers* will be replaced without charge provided that claim is made to the Treasurer within 30 days after date of following issue.

*Remittances* should be made payable to "Washington Academy of Sciences" and addressed to the Treasurer, H. S. RAFFLEYE, 6712 Fourth Street, N.W., Washington 12, D. C.

*Exchanges*.—The Academy does not exchange its publications for those of other societies.



# JOURNAL OF THE WASHINGTON ACADEMY OF SCIENCES

VOLUME 41

May 1951

No. 5

PHYSICS.—*The limitations of the principle of superposition: II.* PAUL R. HEYL,  
Washington, D. C.

The first paper on this subject was published in this JOURNAL 40:345, 1950, wherein the discussion was confined to the case of the resultant of components with equal frequencies. The present paper discusses the case where the frequencies are different. Here we find some rather unexpected results, all of which originate in one fundamental proposition—that with components of different frequencies the resultant does not obey Hooke's law.

Consider first the case of equal frequencies:

$$y = A \sin nt + B \sin n(t - \theta)$$

$$d^2y/dt^2 = -n^2 [A \sin nt + B \sin n(t - \theta)]$$

Assuming a vibrating element of unit mass, we see that the force acting on the element is proportional to the displacement, obeying Hooke's law.

With components of different frequencies,

$$y = A \sin nt + B \sin m(t - \theta)$$

$$d^2y/dt^2 = -An^2 \sin nt - Bm^2 \sin m(t - \theta),$$

where the force acting is not proportional to the displacement but is a variable function of the displacement. To see what results this brings we shall consider a very simple case:

$$\text{Resultant } \begin{matrix} y_1 = \sin t & y_2 = \sin 2t \\ y = \sin t + \sin 2t \end{matrix} \quad (1)$$

Table 1 gives numerical values of displacement, force acting and ratio of force to displacement for a number of points in the first half cycle.

The ratios at  $t = 0^\circ$  and  $t = 180^\circ$  are of an indeterminate form which, when evaluated, give the limits to which the ratios approach at the neighboring points.

It will be seen that the curve has a point of inflexion when  $t = 97^\circ 10' 50''$ . Here the force acting is zero, while the displacement

is not zero. A case of opposite kind is found when  $t = 120^\circ$ . Here the curve crosses the axis and the displacement is zero, but the force is not zero.

A more readily understandable case of this latter kind is found if we consider a flexible string of length  $\pi$ , fixed at both ends and vibrating in its first and third harmonics (see Fig. 1). Here we have, at maximum displacement,  $y = \sin x + \sin 3x$ , with the middle point of the string on the axis of  $x$ . At this moment let the points B and C be held stationary. The middle point A will then snap upward and finally come to rest on the straight line between B and C, showing that it had a force acting on it when its displacement was zero.

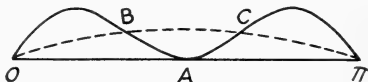

FIG. 1

Another unexpected result appears also in this table. The displacement has a maximum when  $t = 53^\circ 37' 29''$ , but the greatest force occurs at  $t = 47^\circ 25' 33''$ . A similar result is found for the minimum value of  $y$  at  $t = 147^\circ 27' 37''$ , with the maximum force at  $t = 137^\circ 39' 1''$ .

Let us now consider the question of energy. The components  $y_1 = \sin t$  and  $y_2 = \sin 2t$  have respectively total energies of  $\frac{1}{2}$  and 2, whose sum is 2.5. What will be the energy of their resultant?

$$\text{Kinetic energy} = \frac{1}{2}(dy/dt)^2$$

$$= \frac{1}{2}(\cos t + 2 \cos 2t)^2$$

$$= \frac{1}{2} \cos^2 t + 2 \cos^2 2t + 2 \cos t \cos 2t \dots (2)$$

The first two terms of (2) represent the kinetic energies of the original components  $y_1$  and  $y_2$ . The third term is an excess (or deficiency) of kinetic energy which is introduced by adding amplitudes, since the square of a binomial may be greater or less than the sum of the squares of its two terms. If  $t = \pi/4$  or  $\pi/2$  there will be no excess or deficiency, and only in such cases will superposition be valid.

To determine potential energy we must know the force necessary to balance the force of restitution.  $d^2y/dt^2 = -\sin t - 4 \sin 2t = -F$ , the force of restitution, negative when displacement is positive. Therefore  $F$  will be the force we need to determine potential energy. Both  $F$  and  $y$  are functions of  $t$ .

$$\text{Potential energy} = \int_0^y F dy = \int_0^t F dy/dt dt$$

$$= \int_0^t (\sin t + 4 \sin 2t)(\cos t + 2 \cos 2t) dt$$

This splits up into four integrals.

$$\int_0^t \sin t \cos t dt = \frac{1}{2} \sin^2 t \dots\dots\dots (3)$$

$$2 \int_0^t \sin t \cos 2t dt = \cos t - \frac{1}{2} \cos 3t - \frac{2}{3} \dots (4)$$

$$4 \int_0^t \sin 2t \cos t dt = -\frac{2}{3} \cos 3t - 2 \cos t + \frac{2}{3} \dots (5)$$

$$8 \int_0^t \sin 2t \cos 2t dt = 2 \sin^2 2t \dots\dots\dots (6)$$

Here we see that with more than two components the mathematical labor rapidly mounts up. With two components we have four integrals to handle; and with ten components we would have a hundred integrals. But, as was mentioned in the first paper on this subject, there are a number of cases of practical importance where the traditional addition of amplitudes gives correct results.

The sum of these four integrals will be the potential energy of the vibrating element at displacement  $y$ . Of these four, (3) and (6) will be the potential energies of the components  $y_1$  and  $y_2$ . The sum of (4) and (5) will be the excess (or deficiency) of potential energy in

the resultant. Adding the kinetic energy (2) to the sum of these four integrals we have

$$\text{Total energy} = \frac{1}{2} + 2 + 2 \cos t \cos 2t - \cos t - \cos 3t + 2,$$

in which the trigonometric terms cancel out after a little reduction,<sup>1</sup> and we have

$$\text{Total energy} = \frac{1}{2} + 2 + 2 = \text{component energies} + 2 \text{ units excess} \quad (7)$$

which is constant for all values of  $t$ .

This violation of the conservation of energy can be avoided by applying modifying factors to the original components  $y_1$  and  $y_2$  before adding their amplitudes. Let these factors be  $M_1$  and  $M_2$ . The modified components will be

$$y'_1 = M_1 \sin t \text{ and } y'_2 = M_2 \sin 2t, \text{ and their resultant } y = M_1 \sin t + M_2 \sin 2t \quad (8)$$

Working with (8) as we did with the resultant of the original, unmodified components, we obtain

$$\text{Total energy of (8)} = \frac{1}{2}M_1^2 + 2M_2^2 + 2M_1M_2 \quad (9)$$

TABLE I

$t$	$y$	$d^2y/dt^2$	Ratio
0°	0	0	0/0 = -3.00
20°	0.98481	-2.91318	-2.95
40°	1.62670	-4.58203	-2.81
47° 25' 33"	1.73280	-4.72200	-2.73
50°	1.75085	-4.70528	-2.69
53° 37' 29"	1.76014	-4.62520	-2.53
60°	1.73206	-4.33115	-2.48
90°	1	-1	-1.00
97° 10' 50"	0.74412	0	0
100°	0.64279	0.38327	0.60
110°	0.29690	1.63147	5.49
115°	0.14027	2.15785	15.39
120°	0	2.59809	∞
125°	-0.07946	2.93961	-37.00
130°	-0.21877	3.21732	-14.69
137° 39' 1"	-0.32206	3.30922	-10.28
140°	-0.34202	3.29645	-9.64
147° 27' 37"	-0.36901	3.08944	-8.37
150°	-0.36603	2.96412	-8.10
170°	-0.16837	1.19443	-7.11
180°	0	0	0/0 = -7.00

<sup>1</sup> The terms in question are:  
 $2 \cos t \cos 2t - \cos t - \cos 3t \quad (1')$   
 $\cos 3t = \cos(t + 2t) = \cos t \cos 2t - \sin t \sin 2t$   
 Substituting this, the terms in question become  
 $\cos t \cos 2t - \cos t + \sin t \sin 2t \quad (2')$   
 Now  $\cos t \cos 2t + \sin t \sin 2t = \cos(t - 2t) = \cos(-t) = \cos t$   
 Substituting in (2'), the terms all cancel out.

Equating this to the sum of the energies of the original components we have one equation for  $M_1$  and  $M_2$ .

$$\frac{1}{2}M_1^2 + 2M_2^2 + 2M_1 M_2 = \frac{1}{2} + 2 \quad (10)$$

A second equation for  $M_1$  and  $M_2$  is needed.

It is physically reasonable to suppose that the original components  $y_1$  and  $y_2$  should contribute to their resultant in proportion to their respective energies. Therefore the coefficients of  $y_1'$  and  $y_2'$  should be proportional to the square roots of the energies of the original components.

$$\frac{M_1}{M_2} = \left(\frac{\frac{1}{2}}{2}\right)^{\frac{1}{2}} = \frac{1}{2}$$

which gives  $M_2 = 2M_1$ . Eliminating  $M_2$  between this and equation (10) we get

$$M_1 = 5^{-\frac{1}{2}} \quad M_2 = 2(5)^{-\frac{1}{2}}$$

and the resultant becomes

$$y = 5^{-\frac{1}{2}} \sin t + 2(5)^{-\frac{1}{2}} \sin 2t \quad (11)$$

whose total energy for all values of  $t$  is equal to 2.5, the sum of the energies of the original components.

For more than two components the foregoing is easy to generalize. For  $n$  components there will be  $n$  modifying factors. In addition to the generalized form of (10) there will be  $(n - 1)$  ratios between the  $n$  modifying factors, giving  $n$  equations for their determination.

Table 2 gives for the resultant (11) values of displacement, force acting and ratio of force to displacement for points in the first half cycle, as in Table 1. In addition this table gives energy values.

It will be seen in this table that while the total energy remains constant the kinetic and potential energies fluctuate, the potential energy having maxima corresponding to the maximum and minimum values of  $y$ ; and at these points the kinetic energy is zero. The same peculiarities found in Table 1 occur here; potential energy and  $d^2y/dt^2$  do not have the same maxima, and the values of the ratios at  $0^\circ$  and  $180^\circ$  are indeterminate and the evaluated values are given.

TABLE 2

$t$	$y$	$d^2y/dt^2$	Ratio	Potential energy	Kinetic energy	Total energy
$0^\circ$	0	0	-3.40	0	2.5	2.5
$20^\circ$	0.727883	-2.45319	-3.37	0.896899	1.60309	2.49999
$40^\circ$	1.168301	-3.81081	-3.26	2.28665	0.21335	2.50000
$46^\circ 14' 20''$	1.216580	-3.89735	-3.20	2.47308	0.026908	2.49999
$49^\circ 39' 25''$	1.223492	-3.87154	-3.17	2.50000	0	2.50000
$50^\circ$	1.223424	-3.86594	-3.16	2.49973	0.00027	2.50000
$70^\circ$	0.995171	-2.73027	-2.74	1.75899	0.74101	2.50000
$90^\circ$	0.447214	-0.447214	-1.00	0.9	1.6	2.5
$93^\circ 35'$	0.334754	0	0	0.87490	1.62510	2.50000
$100^\circ$	0.134506	0.78323	5.82	0.95361	1.54639	2.50000
$104^\circ 28' 39''$	0.000001	1.29904	$\infty$	1.09375	1.40625	2.50000
$110^\circ$	-0.154683	1.88978	-12.22	1.33978	1.16023	2.50001
$130^\circ$	-0.538252	3.18076	-5.91	2.32114	0.17886	2.50000
$136^\circ 17' 42''$	-0.584481	3.26856	-5.60	2.47062	0.02939	2.50001
$140^\circ$	-0.593375	3.23589	-5.45	2.49948	0.00051	2.49999
$140^\circ 34'$	-0.593533	3.22632	-5.42	2.5	0	2.5
$150^\circ$	-0.550992	2.87464	-5.22	2.37141	0.12859	2.50000
$170^\circ$	-0.228255	1.14509	-5.02	1.73051	0.76948	2.49999
$180^\circ$	0	0	-5.00	1.6	0.9	2.5

ETHNOLOGY.—*Some medical beliefs and practices of the contemporary Iroquois Longhouses of the Six Nations Reserve.*<sup>1</sup> MARCEL RIOUX, National Museum of Canada, Ottawa, Canada. (Communicated by William N. Fenton.)

A member of an Iroquois Longhouse is considered to be an individual who does not belong to any of the Christian sects and is regarded by his fellow members as a believer in the doctrine of Handsome Lake, a native prophet who, at the beginning of the nineteenth century, established a new religion among his people. Although this doctrine is strongly influenced by Christian beliefs and practices, it has served to preserve and consolidate many traditional Iroquois ideas and customs. The name "Longhouse" also designates the building where the adherents of the Handsome Lake cult hold most of their religious rituals and ceremonies. The percentage of the Longhouse worshipers is about one-fifth of the Iroquois population—approximately 5,500—of the whole Six Nations Reserve. The majority are located on the "lower"<sup>2</sup> end of the reserve and form a homogeneous group; the Christians in this area are very few. Three of the four Longhouses on the reserve are located there, and the fourth, the Upper Cayuga Longhouse, stands just beyond the boundary of what could be considered the Longhouse district. The affairs of both the Pagans and the Christians are taken care of without discrimination by the Indian Affairs Branch of the Canadian Government. Between the two groups no other frontier exists but the cultural, and both have practically the same historical background.

Every Iroquois tribe is represented on the reserve, but unevenly. Almost all the Mohawks, Oneidas, and Tuscaroras, who represent more than three-fifths of the entire population, are Christians; the next fifth of Christians consists of Senecas Kanedagas, Onondagas Bearfoot along with some Upper Cayugas, and a few Lower Cayugas. The Cayugas form the bulk of the Longhouse

believers; among them, the Lower Cayugas, who are more numerous than the Upper, are the most coherent Longhouse group. The Upper Cayugas alone are located outside of the Longhouse area. This group has shown signs of disintegration in recent years, and members are not so staunch in their outlook and practices as they used to be. Whereas the Mohawks, Cayugas, Oneidas, and Tuscaroras constitute homogeneous religious groups, the Senecas and Onondagas are divided among themselves. Should we follow in our analysis the paternal line of descent, as is done officially by the Indian Affairs office, and increasingly by the Longhouse themselves who abandon the traditional maternal line, we will find that no Longhouse worshiper is found among the Bearfoot Onondagas, while there are not more than two or three among the Senecas Kanedagas. On the other hand, most of the Onondagas Clearsky and the Senecas Wharondas or Aughanagas are Longhouse supporters. Are the roots of this divergent religious evolution historical or could this split be explained in terms of the present location of the various tribes and subtribes of the Reserve? We note that most of the Senecas and Onondagas who live among the Cayugas belong to the Handsome Lake religion, and those living with the Mohawks are Christian.

Although a full explanation of the actual state of the beliefs and practices of the Longhouse people concerning medicine could not be reached before other aspects of their culture are taken into account and discussed in relation to one another, a brief outline of some of the points under study is given here.

A cultural trait, it seems, may be replaced only when the borrower finds in a new trait an advantage over the one being discarded, and when the new trait can be readily assimilated by the old culture. To explain the diffusion of technical traits from one society to another, one has to find out whether the dominated society is at a favourable enough technical level to make use of the traits which are offered to it. Leroi

<sup>1</sup> I spent part of the summers of 1949 and 1950 among the Longhouse Iroquois of the Six Nations Reserve near Brantford, Ontario, with the view of determining the degree and rhythm of acculturation of this social group. The survey was sponsored by the National Museum of Canada, Ottawa.

<sup>2</sup> This designation appears to be not merely geographical; it connotes a value-judgment when uttered by Christian Iroquois of the "upper" end.

Gourhan<sup>3</sup> states that diffusion does not take place when (1) the ethnical group, being in a state of technical inferiority cannot understand the principles of the new technical traits, (2) when an ethnical group, being in a state of technical inertia, does not see the need of making any effort to assimilate the new traits, and (3) when the ethnical group, being in a state of intensive technical development, neglects what other groups have to offer. Could we not add that there are cases of partial diffusion when a group, for pragmatic reasons, accepts certain new traits and still keeps the older complex because its ideological culture, which does not follow the same rhythm of acculturation as the technical and social cultures, is still linked with the older technical traits?

These principles could explain the adoption by the Iroquois of a vast amount of European technical traits and the abandonment of practically all their technical culture. The few native traits still retained mostly appertain to medicine. In the old Iroquois culture, medicine formed a focus of importance, secondary only to political organization and to the agricultural complex, and for this reason, it should subsist longer than other complexes of lesser importance. Medicinal beliefs and practices, intimately linked with their traditional rituals and mythology, remain in accord with the structure of their personality, which has not changed as fast as the external aspects of their culture. Their great mechanical ability has enabled them to grasp the intricacies of much of the European technology and to assimilate it; yet, on the whole, some of their cultural postulates or themes have prevented them from discarding magical beliefs and practices. As we shall see later, native medicine and European medicine can coexist, while some practices cannot continue to exist in the presence of others and have, as a matter of fact, disappeared or are regressing constantly. For instance, the folk are still very fond of corn bread, yet they do not as a rule take the trouble to use it because their modern habits do not leave them enough time to prepare it.

<sup>3</sup> LEROI-GOURHAN, ANDRÉ, *Milieux et techniques*: 398-399. 1945.

Their medicine may be divided into two parts: the first rests on their traditional knowledge of the curative properties of herbs and other plants; it is empirical. The other may be called magical; it consists of beliefs and practices in which, from the point of view of the observer, no logical link is apparent between the means taken for a cure and the results expected. As Murdock<sup>4</sup> points out, magical beliefs and practices are characterized, among other things, by effort to produce effects "in following out some mystical principle or association of ideas." For instance, a fortune-teller says to a dyspeptic person: "You must hold an Eagle dance because your mother when alive, used to put on an Eagle dance from time to time. But since she died nobody has ever given one." We may now ask whether the Iroquois make a distinction between these two types of medicine, empirical and magical. Observations to be given here presently, tend to show that they make a distinction between the two kinds of medicine but that it is not made at the intellectual but at the affective level; they seem to yield to different kinds of sentiments when, on the one hand, they go to the hospital and when, on the other hand, they resort to the fortune-teller or to the witch. On the whole, they are inclined to resort to the white doctor or to their medicinal plants whenever their ailment appears to them as being well localized and easy to diagnose; but they turn to a fortune-teller and sometimes to a witch when their trouble seems mysterious. As an informant stated, some diseases are for the white doctor to cure and others for the fortune-teller. Their basic criterion for establishing a distinction between the various ailments they suffer appears to be the element of mystery lacking in the first and present in the others; their emotions rise in intensity in proportion with the mystery involved; they soon pass from fear to anguish.

If we call empirical that part of Iroquois medicine which is based on the knowledge of the curative properties of plants and herbs, we can state that this practice does

<sup>4</sup> MURDOCK, G. P., in *Dictionary of sociology*, Fairchild, H. P. (ed.): 180.

not belong exclusively to the Longhouse worshippers; for some of the Christians still use Iroquois medicine. But, as everything traditionally Iroquois, it has a tendency to be identified with Longhouse people and culture. In a few cases of passage from Christianity to the Handsome Lake religion, the reason given to me for the conversion was the good effect Iroquois medicine had on some people who were very ill. Because the whites often express their confidence in and admiration for Iroquois medicine, the Christian Iroquois still keep a verbal, if not a practical, attachment to their own tradition. As this does not conflict with their Christian faith, it has been kept as a compensatory element; there is a strong inclination to retain it in both Christian and Longhouse groups, because it belongs to them and for that reason, has become a source of pride. To overcome the complex of inferiority they have towards the white, they are apt to boast that they had and still have a powerful medicine.

If empirical Iroquois medicine is idealized more than practiced among the Christians it is still in use among the Longhouse people who link it with the Handsome Lake religion and native beliefs and customs. Today medicine has gathered around itself other traits which formerly were not so intimately linked with it. If the Iroquois institution of giving personal names is still maintained by a good many Longhouse adherents, it is done, so some chiefs say, to keep the medicine practices functioning. In some rituals, especially where a tobacco offering is made, the name of the person for whom the ritual is performed must be mentioned; as the rituals are conducted in the Indian dialect, the name itself should also be mentioned in that tongue because if the name were uttered in English (Christian name) the Great Spirit would not know the person concerned. Medicine appears to be one of the last Indian complexes the Longhouse will abandon; it is of great importance in keeping their culture functioning as distinct from that of the whites. As early as in 1912, Goldenweiser wrote: "The Societies of the Iroquois, whatever their history may have been, are at the present time medicinal in

their functions."<sup>5</sup> Most of the societies he mentions have kept functioning today despite the increasing pressure of the white culture; it is mostly around this medical complex that the cultural resistance to assimilation has centered and crystallized. At the Green Bean Festival of last summer, I met a young man who had moved out of the Longhouse district some years ago and is now working among the Christian Mohawks. As he belongs to a family of Longhouse believers, he comes back to the Longhouse for seasonal festivals, and came this year as usual. But he stayed in his car instead of joining the dance inside. He was on the verge, so he confessed to me, of abandoning that religion and of becoming a Christian; the only reason which kept him from making this move, said he, was the Iroquois medicine. "If I quit, I will lose all the benefits of our good medicines, and these I don't want to give up."

The economic aspect of medicine, which in peasant societies plays an important role in the retention of folk practices, works here in the opposite way. In French Canada, for example, the physician lives ordinarily far from the farms and charges his customers for his services; these factors influence the peasant to cling to his old ways. At the Six Nations Reserve the doctors and hospital are located near Indian homes and their medical services to the natives are given free. On this same question of empirical medicine, there exists another difference between the practices of the peasant and the Iroquois. As the plants and herbs of the Iroquois belong to the past when the tribes lived in the woods in the midst of an undisturbed native flora they are now scarce and difficult to find. The peasants, on the contrary, use plants and herbs usually domesticated and close at hand.

When it comes to magical medicine, the split between Christians and Longhouse people becomes more accentuated. Although there are instances in which Christians have, in desperate cases, resorted to the fortune-teller, they are becoming rarer every year.

<sup>5</sup> GOLDENWEISER, A. A. "On Iroquois Work," in *Summary Report of the Geological Survey*: 464-475. Department of Mines, Ottawa, 1912.

The Christians, as a whole, have forsaken the rituals and observances connected with medicine and even if a fortune-teller told one of them to put on a Buffalo dance, he would not be able to perform it or to have it performed by his neighbour. The Christians have been under the influence of the church for so many years—about 300—that they have lost even the idea of the fortune-teller or the witch.

The beliefs and practices of the Longhouse are not altogether uniform. Various degrees of acculturation prevail here. Some people are more conservative than others; some are becoming open to outside influences. But, on the whole, they have a corpus of beliefs and of conscious and unconscious attitudes which link them together very strongly. Among them, we find three categories of medical practitioners. The Indian doctor proper is the best known among the whites, as he often dresses in ceremonial garments, takes part in exhibitions, county fairs, and sells medicine outside the Reserve; he acts like an emissary of Iroquois culture. There are now two or three Indian doctors of this type on the Six Nations reserve. Though their journeys and association with the whites have won them some prestige among their Longhouse compatriots, they do not enjoy the same esteem among their people as does the fortune-teller or even the witch. The folk are inclined to talk about them with a little disdain and to remark that this kind of a doctor is primarily a moneymaker; they do not consult him as often as the others; they may be proud of his successes at large but as he does not often associate with them, their preference goes to the fortune-tellers and the witches who join them in all ceremonies and rituals.

The fortune-teller, a man or woman, is not outwardly different from the other Longhouse people. But he or she is a person "who knows a lot of things" and this knowledge carries great prestige among the conservative elements of the population. He does not usually ask for money in payment for his services, but tells his patients to give him what they consider fair compensation. His ways of finding out what is good for a patient are many: dreams, leaves of tea, cards, the absorption by himself of certain medicines,

simple questioning, and the summary examination of the patient. His prescriptions are varied: herb and bark medicines, mixed plant and magical recipes, or just magical devices. He stands midway between the European doctor who resorts only to empirical medicine and the witch who resorts to magic. At times, the fortune-teller introduces preventive medicine by ordering, at the beginning of summer or winter, a remedy which keeps away the diseases common in that season of the year; this practice is dying out. Most of his efforts, however, are directed to mysterious and difficult cases, where he will ordinarily prescribe a ritual dance, a feast or a game with or without the use of herbs and plants.

The third group of practitioners concerned with health is more exclusive and very secretive. It takes a long time for an outsider to learn their names and to get any information about their black art. People ordinarily resort to the witches<sup>6</sup> when all other means have been exhausted. As it is admitted, witches are becoming rare and their activities are hidden even to the Longhouse believers themselves. According to some informants, those who aspire to become witches must try their power on a member of their own family by bewitching this person to death. For this very reason even their names remain secret. No witch can denounce another witch without denouncing himself. The feelings of the people in regard to witches and to witchcraft are ambivalent. On the one hand, the witch is feared and reprobated for his malefic power; and the code of Handsome Lake is very severe for witches. But, on the other hand, the people cannot help being fascinated by his great powers and they try to know their names and to get in touch with them. The best and the worst are often intimately linked, and excessive admiration and reprobation are sometimes merged in the minds and reactions of the people. Maleficious witchcraft and benevolent medicine are closely connected and the same plant may at times be used for both medicine and witchcraft, depending on the intentions of the person who collects the roots from which the powerful medicine or magic is

<sup>6</sup> "Witch" is used on the reserve for both male and female practitioners of witchcraft.

extracted. The more beneficial a medicine is, the worse it can be if used to bewitch. Their most powerful medicine today, according to my informants, is Niganèga'a', a powder extracted from a plant which is said to grow only at Salamanca, in New York State. Those who go there to collect the plant from which the "good medicine" is extracted observe strict rules; they must follow the plant with their hands from the top to the tips of the roots, deep in the soil. If the plant breaks during the operation, the search for another must start all over again as only plants pulled up in their entirety without being broken in any of their parts are suitable. Even when the ends of the roots have been reached without accident the only roots that are brought are those which grow from the east to the west—in the direction that the sun follows. Those growing from the North to the South must be avoided. However, somebody whose ambition it is to become a witch can pick these roots; they are used for the most powerful witchcraft. It is admitted, however, that the younger generation knows very little now about witchcraft; beliefs and practices are being lost; the idea of witchcraft is still entertained by a good many people but the witches themselves seem to be less active and less numerous.

Of the medicine men enumerated above, the fortune-teller is today the most active among the Longhouse people of the Six Nations Reserve. Of them Parker says: "Diviners of mysteries have always been prominent among the Indians. Their office was to tell their clients the proper medicine society that would be more efficacious in curing the sick, to discover the whereabouts of lost children and articles, to discover what witch was working her spells, and to tell fortunes, as well as to interpret dreams."<sup>7</sup> The function of the fortune-teller is similar nowadays, except that the first function described by Parker is much more to the fore than the others. The only other comment to be made on Parker's quotation is that witches may be male or female, not only female as he seems to imply. Indeed, the best-known witches now are mostly men.

<sup>7</sup> PARKER, ARTHUR. *The code of Handsome Lake*: 49-50. 1012.

A question comes up as to a possible parallel between the switching of this function from women to men and the constant regression of what was known as the Iroquois matriarchate. The people usually resort to the fortune-teller for illnesses which appear mysterious to them, mostly internal diseases with many symptoms. Although I know of a man having gone to a fortune-teller for appendicitis, diagnosed as such by a white doctor, and another one for an abscess in the leg, it seems that in such cases most Longhouses would have gone to the hospital. Acculturation processes<sup>8</sup> have been in operation for so long that it is safe to state that in most instances where the diseases are external and well diagnosed, the patients consult the doctor first before going to the fortune-teller or to the witch.

The wife of one of my informants came back from the fruit country where she had been "picking" for about two months and complained about her health. She had a poisoned tooth and felt other symptoms that made her "very sick." She had lost her appetite, was dizzy at times, and in the morning had a funny taste in her mouth; she also had pains in the abdomen. As she was going to the hospital to have her tooth extracted, I advised her to consult the doctor about her other troubles. She answered that it was not a case for the doctor but for the fortune-teller. She went to the hospital, came back three or four days later, and called the fortune-teller who told her that her dead husband was hungry and she must "put up" a feast for him. Obviously, there was in her mind a clear distinction between various illnesses: the ones which can be cured by the doctor, the others by the fortune-teller.

In another family I often visited, the mother told me she was not feeling well; she had about the same symptoms as the other woman just mentioned: loss of appetite, dizziness, pains in the head. She went to the fortune-teller who recommended a Bear dance; she was very grateful to him because she got better a few days after. Some time later, her oldest son was hit when stepping off a truck, and was bleeding

<sup>8</sup> FENTON, W. N. *Contacts between Iroquois herbalism and colonial medicine*. Ann. Rep. Smithsonian Institution, 1941: 501-526.



heavily; her first thought was to call for a doctor and to take her son to the hospital. As in the previous instance, the woman believed that one disease was to be cured by the fortune-teller, another by the white doctor.

Many people, however, do not take chances and go to both the doctor and the fortune-teller for the same illness. It sometimes happens that having gone first to the physician they stop seeing him and consult a fortune-teller, particularly when a long treatment is required; very soon they get discouraged and revert for help to their magical practices and medical societies. In many cases when they call the doctor, it is really too late. Seeing that their medicine has failed, they call for the doctor and sometimes go to the hospital just to die. This practice does not improve people's confidence in the hospital.

I have studied the life of a Lower Cayuga of the Handsome Lake faith who, in many respects, is typical of his culture; he has spent all his life on the reserve, in the Longhouse area, and has undergone the same influences as the majority of his fellow-believers. But even among the Longhouse believers, the effects of acculturation, as I have been able to observe them, are not uniform. Some people are very conservative on certain points while partial to new beliefs and practices. It seems that idiosyncrasies have much to do with the picking up of traits within a certain range. The informant just referred to, in matters of rituals and religious beliefs, is very strict while he could not help laughing at some of the Iroquois folk tales and myths; his wife, on the contrary believed in all myths and tales while she did not care very much for the rituals. In all matters of health and medicine, he was a very good informant because, being sick himself, he was personally interested. At various periods of his life, he had consulted the doctor for himself and for his family. As the doctor usually was successful, he had developed a high opinion of him and of his medicine. But I found that on serious matters, he had not taken chances, and he has used both the doctor and the fortune-teller. He is a member of the Bear, Otter, Eagle, and False Faces societies, all of them

concerned with health. From time to time he "puts up" a dance to prevent any illness caused by negligence in not keeping the rules of the societies. In going over the various illnesses he and his family suffered, I am unable to detect the reasons he had gone to the doctor in certain cases and to the fortune-teller in others; except for face distortion and nose bleeding which are ailments for the False Faces to cure, I could not ascertain on what grounds the distinction between illnesses was made. Some of the illnesses began while the family was out in the fruit country where a fortune-teller was not available; had they happened on the reserve it might have been different; in other cases, the doctor or the fortune-teller was called, when one or the other failed to give satisfaction.

About five years ago, Pat fell from a barn, and although no bone apparently was broken he called for the fortune-teller to administer him some "Niganēga 'a'", the good medicine." As it did not work—nothing was broken—he called a doctor, because he still felt very sick. After a thorough examination the doctor said that nothing was wrong with him and gave him some pills. Since that day, however, he has not been able to work; he always complained about headaches and stomach and intestinal troubles. Once in a while he calls on a doctor—every time a new one comes on the reserve—and now and then he sees a fortune-teller. When he finds that the prescription of the fortune-teller does not cure him, he is apt to think that he has not enough confidence in the traditional dances and feasts and blames it on himself for not being cured.

One day, after discussing his problems, he told me that the only answer was that he had been bewitched; the more he thought of it, the more he believed that he had all the symptoms of a bewitched person. "When nobody knows the cause of headaches, pains, loss of appetite, it is sure that the one who suffers these ailments has been bewitched." It was the first time he mentioned this suspicion to me, yet it had occurred to him long ago, as soon as the doctor he had consulted first had told him he did not know what was wrong with him. For a year now his conviction had grown firmer; his wife had

then consulted a fortune-teller who was picking berries with her and told her that she knew that Pat, my informant, had been bewitched by a relative of his who had reasons to complain about his behaviour. From that time on he was busy with his wife trying to find out the person who had caused harm to him. Every possibility was examined patiently and finally the conclusion was reached that it was a woman with whom he had had some trouble about a horse and a succession. This particular woman seemed to fit the words of the fortune-teller: she was a relative, she might have had some reasons to be angry at him and she was thought by many to have practiced magic in the past and still to practice it. But his trouble did not end there. Pat had then to find another witch who could counterbalance the influence of the first. As the activities of the witches are secret and are known only by hearsay, finding a stronger one was by no means easy. The only one in sight, powerful enough, was not on good terms with him. At the time he took sick, five years ago, this witch, who is also a fortune-teller refused to give him "good medicine," under the pretext that he did not have enough of it; my informant had to beg the Onondaga keeper of the medicine for it, which he did not like to do. This medicine is all the same whether it comes from an Onondaga or from a Cayuga, but the portion that the Cayuga keeper has should be used for Cayugas. Since that time, he has hardly talked to him, and now feels hesitant to ask any other favours. As a result of this, my informant was getting more and more perplexed, and the idea that he was bewitched never ceased to grow with him.

An example of the use of both empirical and magical medicine is that of a young man lying in bed with fever. One morning he told his parents that he had seen many little men going up and down on his bed. The parents decided that, on account of this vision, he should be made a member of the Pigmy Society; the same day, the doctor, who had been called previously, decided to bring the lad to the hospital; and the parents, who had

decided to put up a "Dark dance," had to have this done the night after his departure. As he was away, his shirt was placed on a chair to signify that the ceremony was conducted for him, in his absence.

The activities of Iroquois practitioners do not keep their people from going more and more to their own hospital on the reserve. As they are generally less aggressive than the Christians, they are prone to take advantage of the facilities which the whites have placed at their disposal. Yet, in many cases, their stubborn conservatism prevents the Longhouse people, and for that matter the Christian Iroquois as well, from going away from their relatives and friends; they fear any new contacts they may have to make at the hospital. As in peasant societies the in-group-belonging remains strong, despite the constant pressure urban culture exercises on both societies.

Their use of both empirical and magical medicine appears to be a double-security system for the individual. Just because the white medicine succeeds in many cases they do not lose confidence in their own medicine. The differences between these two systems do not bother them very much. They see the white medicine with their own eyes. Not knowing the principles of this medicine, they are apt to think of the white doctor as another kind of fortune-teller. The latter at times mixes empirical and magical medicine and they are not astonished at the practices of the white doctor. It is probably because they make no clear distinction between the two that they also expect from the white doctor a quick cure. Examples of rapid cures are quoted with great admiration and a long cure is no cure. "Next day he was better and went to work" is the happiest solution and the only one worth mentioning.

In further studies on this subject, I will try to show that if some of the old beliefs and practices concerning medicine are still entertained among the Iroquois Longhouse it is because their personality has not been acculturated at the same rhythm as the rest of their culture and that there is still room for faith in magic.

GEOLOGY.—*Present Cretaceous stratigraphic nomenclature of northern Alaska.*<sup>1</sup>

GEORGE GRYC, W. W. PATTON, JR., and T. G. PAYNE,<sup>2</sup> U. S. Geological Survey. (Communicated by W. F. Foshag.)

Until 1944, geologic investigations in northern Alaska were of a reconnaissance nature and few stratigraphic units were recognized and named. Since 1944 the U. S. Geological Survey in cooperation with the U. S. Navy has been investigating the petroleum possibilities of Naval Petroleum Reserve No. 4. These investigations have covered nearly all northern Alaska from the Jago River west to the Kukpowruk River and from the Arctic Ocean south to and in several places into the Brooks Range (Fig. 1). This work has resulted in much more detailed information on the geology of the region. Rocks ranging in age from questionable pre-Cambrian to Pleistocene have been mapped and drilled. Cambrian, Ordovician, and Silurian rocks are not known to crop out north of the crest of the Brooks Range, but all other systems are represented (Fig. 2). To date the Cretaceous rocks have been studied more intensively than the rocks of any other age, and as a result a more detailed classification has been achieved (Fig. 3).

The Cretaceous rocks in the Anaktuvuk (Anaktoovuk) River area of northern Alaska were first described by Schrader.<sup>3</sup> Smith and Mertie<sup>4</sup> redefined the age of some of these rocks and added descriptions of their distribution and lithology. The present study has resulted in many changes in the stratigraphic classification. It is not always possible to tell from the literature what rocks have been included in previously described stratigraphic units and therefore these units may not be strictly comparable to the stratigraphic units introduced here. The apparent relationship of past and present stratigraphic nomenclature is shown in Table 1.

<sup>1</sup> Published by permission of the Director, U. S. Geological Survey.

<sup>2</sup> Authors listed in alphabetical order.

<sup>3</sup> SCHRADER, F. C., *Geological section of the Rocky Mountains in northern Alaska*. Bull. Geol. Soc. Amer. **13**: 247. 1902.

<sup>4</sup> SMITH, P. S., and MERTIE, J. B., JR., *Geology and mineral resources of northern Alaska*. Bull. U. S. Geol. Surv. **815**: 196-232. 1930.

The new classification is here presented and discussed. This classification is based on geologic field studies of the outcrop areas and on laboratory studies by the U. S. Geological Survey during the period 1944 to 1951.

## CRETACEOUS ROCKS

*Lower Cretaceous*

## OKPIKRUAK FORMATION (NEW)

The Okpikruak formation (new) is typically exposed along the Okpikruak River, from which it is named. The type section lies in the middle of a major syncline and is exposed on a small tributary of the Okpikruak River at about lat. 68°34'30"N. and long. 153°38'W. The formation crops out in the southern part of the Arctic Foothills province from the Itkillik River west to the Kukpowruk River. In the Arctic Foothills province, as far as known, it rests on Jurassic or Triassic rocks with little or no angular discordance. At its type locality it is about 2,400 feet thick. To date this is the greatest thickness measured, but an erosion surface between it and the overlying Torok formation indicates that it may be thicker elsewhere. It is predominantly fine-grained greenish-gray sandstone of the graywacke type, dark clay, and silt shale with minor amounts of conglomerate near the base. On the Siksikpuk River, where part of the formation is well exposed, it is 1,850 feet thick. Here it is characterized by a rhythmic alternation of fine-grained sandstone, silt shale, and clay shale. This alternation is not well developed in the formation along the Okpikruak River, although there is a suggestion of it.

The pelecypod *Aucella crassicolis* Keyserling,<sup>5</sup> which is characteristic of early lower Cretaceous (Neocomian) is found throughout this formation in the area of the type locality. The ammonite *Lytoceras* sp. has also been collected in the Siksikpuk River area. In the Nimiuktuk-Kugururok Rivers area on the south side of the De Long Mountains *Aucella okensis* Pavlow and *Aucella crassa* Pavlow have been collected. These

<sup>5</sup> Identification of macrofossils from the Okpikruak and Torok formations have been made by Dr. Ralph W. Imlay.

forms are characteristic of the very earliest Lower Cretaceous and would presumably mark a zone lower than that of *Aucella crassicollis* Keyserling.

#### TOROK FORMATION (NEW)

The type locality of the Torok formation (new) is Torok Creek, a tributary to the Chandler River in the vicinity of Castle Mountain. At Castle Mountain the Torok formation in the lower part comprises 2,000 feet of dark silt and clay shale with limestone concretions, and in the upper part about 8,500 feet of dark shale and marine conglomerate and sandstone of gray-wacke type. In exposures on the Chandler and Kiruktagiak Rivers, in the vicinity of Tuktu Bluff about 11 miles north of Castle Mountain, the Torok formation in the upper part consists of 4,500 feet of dark clay and silt shale, which includes 500 feet of sandstone and some conglomerate, and in the lower part, of 1,500 feet of dark silt and clay shale. Thus at Tuktu Bluff the Torok formation is 6,000 feet thick as compared with 10,500 feet at Castle Mountain.

The Torok formation is widely exposed in an east-west belt in the Southern Foothills section of the Arctic Foothills province. This belt is characterized topographically by irregular, isolated hills and ridges of sandstone and conglomerate, which rise above low-lying areas of little relief developed on the shale. Structurally, many of these isolated hills, such as Castle Mountain and Fortress Mountain, are synclines. At most places the Torok formation overlies the Okpikruak formation, but at one place has been found overlying Triassic rocks, indicating warping and erosion of the Okpikruak formation and Jurassic rocks in post-Okpikruak time. The degree of angular unconformity is unknown, as the contact is poorly exposed.

The fauna of the Torok formation is very scarce but includes some characteristic Aptian and early Albian forms. There are a few species of *Inoceramus*, *Beudanticeras* sp., *Cleoniceras* sp., *Lemuroceras* sp., *Lemuroceras* cf. *L. belli* McLearn, *Lemuroceras* cf. *L. aburensis* Spath, and *Aucellina* cf. *A. dowlingi*. The ammonite *Cleoniceras* sp. also ranges into the overlying Tuktu

TABLE 1.—COMPARISON OF PAST AND PRESENT STRATIGRAPHIC NOMENCLATURE OF THE CRETACEOUS AND TERTIARY OF NORTHERN ALASKA

Schrader, 1902	Smith and Mertie, 1930	Gryc, Patton, and Payne, 1951				
Goobic (Gubik) sands	Quaternary	Quaternary	Gubik formation			
Tertiary Colville series	Tertiary		Tertiary	Sagavanirktok formation*		
		Cretaceous		Upper	Colville group	Prince Creek formation (nonmarine)
Upper Cretaceous Nanushuk series	Upper Cretaceous series		Lower ?		Nanushuk group	Chandler formation (nonmarine)
Lower Cretaceous Anaktuovuk (Anaktuvuk) series	Lower Cretaceous series		Lower	Torok formation		
			Okpikruak formation			

\* Sagavanirktok formation is not equivalent to rocks previously called Tertiary and is not believed to be present in areas studied before 1944.

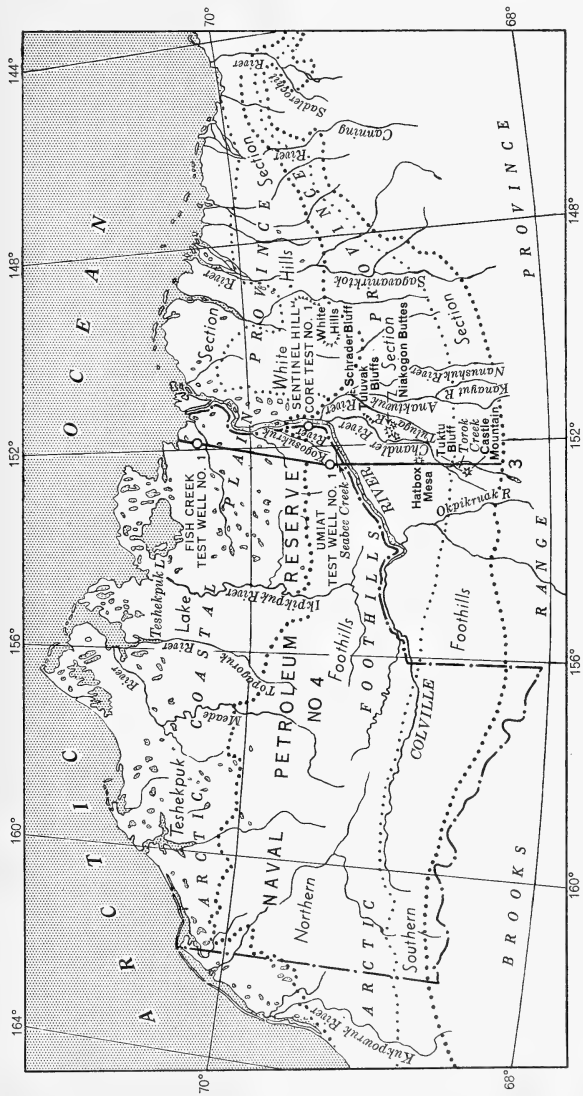

Fig. 1.—Index map of northern Alaska showing location of Fig. 3.

member of the Umiat formation. Arenaceous Foraminifera dominate the microfaunal assemblage.

*Lower Cretaceous and Lower (?) Cretaceous*

NANUSHUK GROUP (REDEFINED)

The Nanushuk "series" was named by Schrader<sup>6</sup> from the Nanushuk River which joins the Anaktuvuk River at about the midpoint of the type section. The type section was described by Schrader as the belt of rocks beginning 5 miles north of the junction of the Colville and Anaktuvuk Rivers and extending south for 30 miles. These rocks were described as sandstone, limestone, shale, quartzite, chert, black slate, and coal. Schrader<sup>7</sup> states that the series is best exposed "in the north (northeast) bank of the Anaktuvuk about 5 miles above the mouth of Tuluga River." This exposure is redescribed here as the type locality of the Schrader Bluff formation (new) of the Colville group (redefined). It is now apparent that rocks described by Schrader as the Nanushuk "series" of Upper Cretaceous age included beds of both Upper and Lower Cretaceous age and possibly older.

The name Nanushuk is here applied to a group of rocks of Lower Cretaceous and Lower (?) Cretaceous age. These are exposed along the Nanushuk River where the river cuts across the Arctic Foothills province of northern Alaska. Rocks of this group are known to crop out throughout the foothills north of the Brooks Range from the Sagavanirktok River west as far as the Kukpowruk River. The contact between the Nanushuk group and the Torok formation is believed to be gradational, but the contact zone generally is not well exposed because of the nonresistant nature of the Torok formation. In the Nanushuk River area the Torok formation appears to dip regionally more steeply than the Nanushuk group, but this is apparently due to a difference in competence. In the Kukpowruk River area the contact appears to be lithologically gradational.

The Nanushuk group includes shale, sandstone, conglomerate, and coal beds with little or no bentonite or tuff. It is estimated to be 5,750 feet thick in the outcrop area, but it thins slightly northward. Nonmarine and marine sedimentary rocks intertongue, as a result of re-

peated marine transgressions and regressions in Nanushuk time. Thus the Nanushuk group includes two intertonguing formations—the Chandler (nonmarine), which tongues into the Umiat (marine) to the north. Fig. 3 shows the relationship of the formations, members, and tongues.

*Umiat formation (new).*—The Umiat formation of the Nanushuk group is named from the marine part of the section below 750 feet in Umiat Test Well No. 1. (See Fig. 3.) In the vicinity of Umiat the inshore facies of the formation consists of relatively clean sandstone that grades northeast through argillaceous sandstone into shale of the offshore facies. The formation is estimated to be about 5,000 feet thick; the lower part is marine shale similar to shale of the Torok formation, which it overlies. Its fauna is almost exclusively mollusks and arenaceous Foraminifera. The lower part of the Umiat formation is Lower Cretaceous (mid-Albian), as determined from the scarce but distinctive mollusks. The upper part of the Umiat formation is probably also Lower Cretaceous (upper Albian), but the fossil data are inconclusive. The Foraminifera show a marked resemblance to those of the Ashville formation of Canada. The Umiat formation has been divided into two members—the Tuktuk and the Topagoruk.

The Tuktuk member is the basal member of the Umiat formation. Its type locality is on the Chandler River where this river cuts through Tuktuk Bluff, a continuous south-facing escarpment that can be traced for many miles. At the type locality the member is about 1,000 feet thick and underlies the Hatbox tongue of the Chandler formation (see below). Here it consists almost entirely of marine sandstone. Northward from Tuktuk Bluff to Umiat the member thickens progressively to about 2,500 feet and includes part of the marine equivalent of the Hatbox tongue of the Chandler formation, as this tongue changes to a marine facies. The characteristic fossil is an undescribed Lower Cretaceous *Inoceramus*. The ammonite *Cleoniceras* ranges from the Torok formation into the Tuktuk member of the Umiat formation. The base of the Tuktuk member coincides with the base of the Umiat formation and the base of the Nanushuk group.

The Topagoruk member of the Umiat formation is named from the section in Topagoruk Test Well No. 1, from 50 to about 3,100 feet. The top 1,000 feet includes nonmarine units of the Niakogon tongue of the Chandler formation and

<sup>6</sup> SCHRADER, F. C., *A reconnaissance in northern Alaska*. U. S. Geol. Surv. Prof. Pap. 20: 79. 1904.

<sup>7</sup> SCHRADER, F. C., *Idem*.

consists of coal, shale, sandstone, and minor amounts of ironstone. The bottom 2,100 feet is entirely marine clay shale, silt shale, silt, and sandstone. Fossils found in this member are Foraminifera, the scaphopod *Laevidentalium*, and *Inoceramus* prisms. It is suggested that these fossils are of Lower Cretaceous age but this is

not definitely established. The Topagoruk member thickens southward and intertongues with the Hatbox and Niakogon tongues of the Chandler formation. In much of the outcrop belt the Topagoruk member is represented by a marine sandstone which contains a diagnostic undescribed *Inoceramus* and other pelecypods.

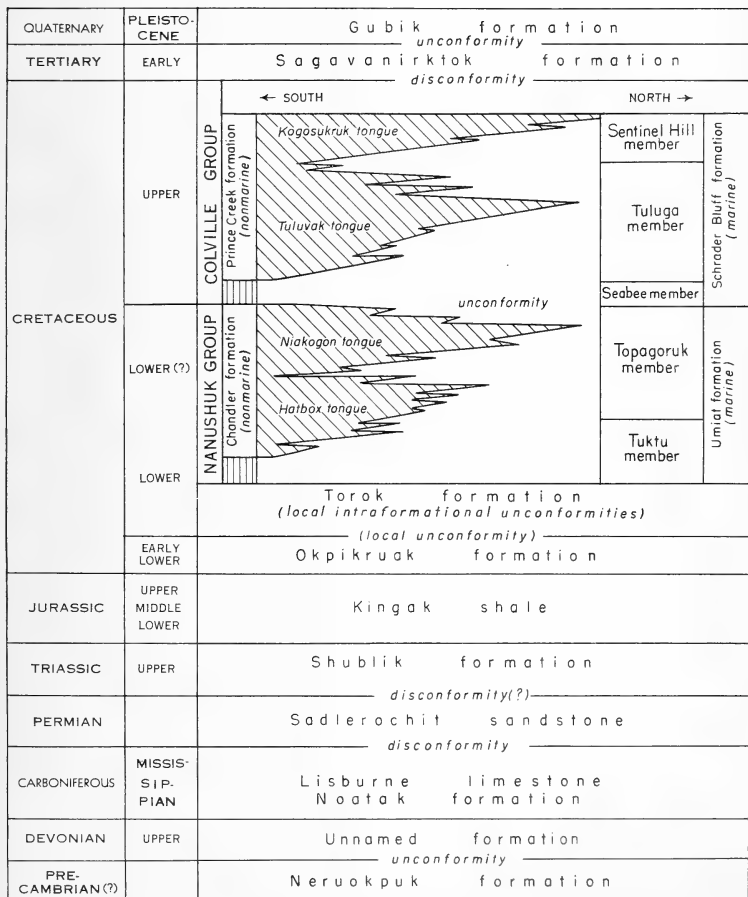

FIG. 2.—Diagrammatic columnar section of the Arctic slope of northern Alaska.

*Chandler formation (new).*—The Chandler formation (nonmarine) is exposed in the Northern Foothills section of the Arctic Foothills province of northern Alaska. It is the age equivalent of the Umiat formation, with which it intertongues northward in two major tongues (named) and several minor tongues (unnamed). Its type locality is on the Chandler River where the river crosses the Northern Foothills section. Lithologically most of the formation in the southern exposures is nonmarine sandstone and conglomerate. To the north it grades into shale with interbedded sandstone and coal; it contains a few fresh- to brackish-water mollusks in its northerly exposures. Along the Chandler River the formation is about 4,700 feet thick but includes minor units of marine strata of the Umiat formation. The Chandler formation overlies the Tuktuk member of the Umiat formation in the southern part of the outcrop area.

The Hatbox tongue (new) at its type locality, Hatbox Mesa in the Chandler River drainage, is approximately 3,000 feet thick and wedges out northward. It is the lower part of the Chandler formation and lies between the marine Tuktuk and Topagoruk members of the Umiat formation.

The Niakogon tongue (new) represents the upper part of the Chandler formation. Its type locality is Niakogon Buttes, between the Chandler and Anaktuvuk Rivers. In the southern part of its outcrop area it is about 1,700 feet thick; it wedges out northward. A persistent conglomerate bed, characterized by a greater percentage of white quartz pebbles than is found in other conglomerates in the region, forms the top bed of the Niakogon tongue.

#### *Upper Cretaceous*

##### COLVILLE GROUP (REDEFINED)

The Colville "series" was named by Schrader from exposures along the Colville River north of the junction with the Anaktuvuk River. On the basis of lithology and scanty floral evidence Schrader<sup>8</sup> concluded that these rocks were of Tertiary age. Smith and Mertie<sup>9</sup> concluded that "from the fossil evidence obtained in the apparent continuation of these rocks farther west" the lower part of the Colville "series" was of Upper Cretaceous age. It is now evident from

microfaunal and macrofaunal evidence that these rocks are all of Upper Cretaceous age. The exposure on the west side of the Colville River 1 mile north of the 70th parallel was considered to be Tertiary by Smith and Mertie<sup>10</sup>. It is now believed that this exposure is of the same age as the Gubik formation, which is Pleistocene. This is apparently substantiated by the lack of any Tertiary beds in the many core tests and test wells in the Barrow-Simpson and Fish Creek areas to the west of the Colville River.

The Colville series is here redefined as the Colville group, applied to type exposures along the Colville River from approximately the junction with Prince Creek east and north to the 70th parallel. Rocks of this group are well exposed in river cuts; on the Colville River these cuts form bluffs that are nearly continuous from Umiat north to Ocean Point. These rocks extend west to about the longitude of the Ikpiqpuk River and east to the Canning River, and perhaps beyond.

The Colville group is separated from the underlying Nanushuk group by a major unconformity. Rocks of lower Upper Cretaceous age (Cenomanian) appear to be missing. Beds of middle Upper Cretaceous age (Turonian) in the Colville group overlie beds of probable uppermost Lower Cretaceous age (Albian) in the Nanushuk group. The basal member of the Colville group is a distinctive unit consisting of black shale with limestone interbeds that can be readily identified in the field. The Colville group is divided into the nonmarine Prince Creek formation and the marine Schrader Bluff formation, which are approximately of equivalent age. In most of the outcrop belt the two formations intertongue and are not always readily distinguishable.

Lithologically the group includes clastic rocks ranging from shale to conglomerate, limestone, low grade oil shale, and coal. The total thickness of the group is about 5,200 feet.

*Schrader Bluff formation (new).*—The name Schrader Bluff formation (marine) is given to exposures at Schrader Bluff on the Anaktuvuk River just south of the junction with the Tuluga River. This bluff exposes the three members of the formation in over 3,000 feet of continuous outcrop. The formation has been identified in

<sup>8</sup> SCHRADER, F. C., Op. cit.: 81-83.

<sup>9</sup> SMITH, P. S., and MERTIE, J. B., JR., op. cit.: 232-233.

<sup>10</sup> SMITH, P. S., and MERTIE, J. B., JR., op. cit.: 235.



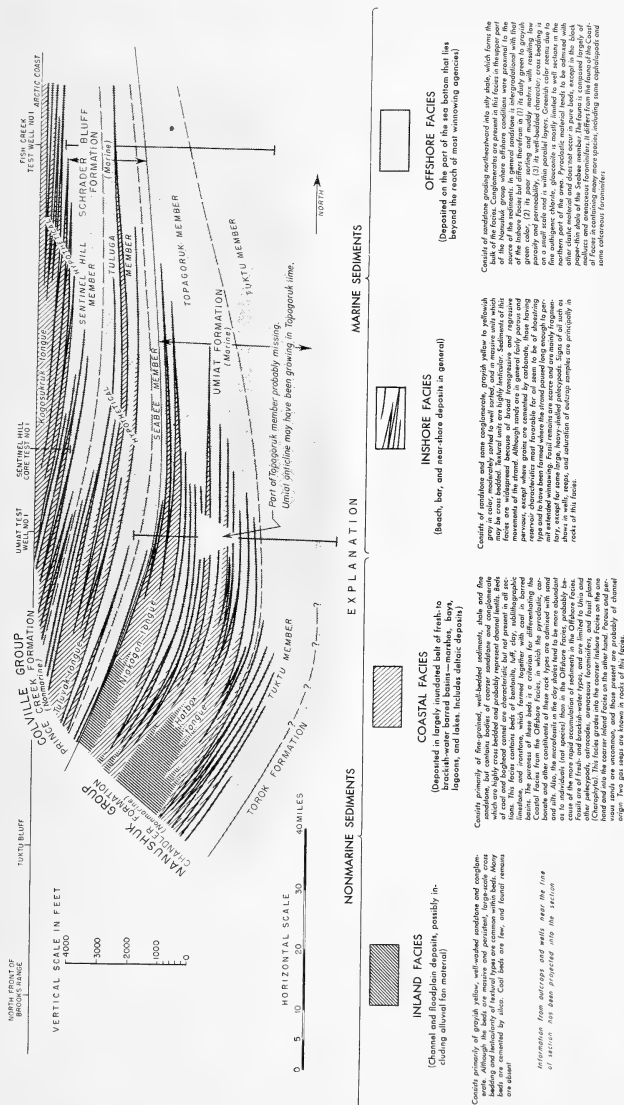

FIG. 3.—Restored facies cross section of the Nanushuk and Colville groups in northern Alaska, showing marine and nonmarine formations and their tongues and members.

well cores from the Umiat, Fish Creek, Sentinel Hill, and Cape Simpson areas. North of Umiat the Schrader Bluff formation is bounded below by the Umiat formation, and in the Umiat area and to the south by the Niakogon tongue of the Chandler formation.

Lithologically it is similar to the Umiat formation, consisting largely of marine sandstone to the south and shale to the north, but it has a much larger percentage of bentonite and tuff, which increases upward through the formation. At Fish Creek Test Well No. 1 it is 2,600 feet thick.

The Schrader Bluff formation contains more megafossils, mostly mollusks, than the Umiat formation. The characteristic megafossils are species of *Inoceramus* and *Scaphites*. Foraminifera are somewhat rarer than in the Umiat formation, but local zones of planktonic forms are present.

The Seabee member is the lowest unit of the Schrader Bluff formation. In the outcrop area it is bounded below by the Niakogon tongue of the Chandler formation. The top part of the Seabee member contains a very distinctive 150-foot unit of fossiliferous paper shale, which is a low-grade oil shale and contains a characteristic fauna. Index fossils are *Scaphites delicatulus* Warren, *Watinoceras* n. sp., *Borissjakoceras* n. sp., and *Inoceramus labiatus* Schlotheim, which indicate that this unit is the equivalent of the Greenhorn limestone of Upper Cretaceous age of the western interior United States. The member is well exposed along a tributary of the Colville River, Seabee Creek, for which it is named. It is also well exposed along Maybe Creek, a tributary of the Ikpikpuk River. The Seabee member is 450 feet thick in the type locality.

The Tuluga member is named from the Tuluga River, which enters the Anaktuvuk River at the north end of Schrader Bluff. Schrader Bluff is the best exposure of this member and is its type locality. The member is also well exposed on the Chandler River near the confluence with the Ayiyak River and on the Colville River in the Umiat area. The maximum thickness is estimated to be 2,200 feet in the outcrop belt, but this thickness includes minor units of the Tuluvak tongue of the Prince Creek formation. In Fish Creek Test Well No. 1, from 1,195 to 2,350 feet, this member is almost entirely marine except for one thin coal bed and associated sandstone.

Lithologically the Tuluga member is distinguished by abundant bentonite and tuff interbedded with a light-colored sandstone, and shale. The Tuluga member contains the largest number of individuals and species of macrofossils of any unit in the Cretaceous of northern Alaska. Fossils are commonly distributed throughout sandstone zones a few hundred feet thick. The diagnostic macrofossils are *Inoceramus lundbreckensis* McLearn and an undescribed *Scaphites*.

The Sentinel Hill member is named from the section in Sentinel Hill Core Test No. 1 in which a little over 1,100 feet of marine beds of this member and nonmarine beds of the Kogosukruk member of the Prince Creek formation were penetrated. In the outcrop belt along the Colville River equivalent intertonguing marine and nonmarine beds total 2,340 feet.

Lithologically the Sentinel Hill member is characterized by volcanic glass shards, abundant bentonite, and tuff. In outcrop the beds are less consolidated than the underlying members. Faunally this member is distinguished by abundant radiolaria, fish bones, and diagnostic Foraminifera. Macrofossils are rare and consist of long-ranging generalized types of pelecypods.

*Prince Creek formation (new).*—The Prince Creek formation of the Colville group includes all the nonmarine beds above the top of the Niakogon tongue of the Chandler formation and intertongues with the Schrader Bluff formation. The type locality is Prince Creek, a tributary to the Colville River. The Prince Creek formation, like the Chandler formation, is made up of sandstone, conglomerate, shale, and coal, but contains considerably more bentonite and tuff than does the Chandler formation. Its fauna consists of a few fresh- to brackish-water mollusks. The Prince Creek formation has been separated into two major tongues.

The Tuluvak tongue, the lower part of the Prince Creek formation, is best exposed in the Tuluvak Bluffs on the Chandler River where it is 1,200 feet thick. It overlies the Seabee member (marine) of the Schrader Bluff formation.

The Kogosukruk tongue is the age equivalent of the Sentinel Hill member of the Schrader Bluff formation. It is named from the Kogosukruk River, along which it is well exposed. Equally good if not better exposures which are more readily accessible are along the Colville River from near its confluence with the Anaktuvuk

River to Ocean Point just north of the 70th parallel. The total thickness along the Colville is 2,340 feet but this includes marine units of the Sentinel Hill member of the Schrader Bluff formation.

The Kogosukruk tongue is distinguished from the older units by its poor consolidation, finer texture and somewhat brighter colors. It consists largely of clay, silt, and shale. Bony coal and bentonitic beds are common. Sandstone is rare, and only one conglomerate, 15 feet thick, has been mapped. Macrofossils are very rare and consist of fresh-water and brackish-water pelecypods and gastropods.

In the outcrop belt this tongue overlies the Tuluga member of the Schrader Bluff formation and is covered by a thin mantle of the Gubik (Quaternary) formation.

### TERTIARY ROCKS

#### *Sagavanirktok formation (new)*

The Sagavanirktok formation crops out in the Franklin Bluffs, its type locality, along the lower part of the Sagavanirktok River and is also well exposed in the White Hills area. It consists mainly of red-bed-type, poorly consolidated siltstone, sandstone, conglomerate, and lignite. No fauna has been found, but the formation does contain an early Tertiary flora. The Sagavanirktok formation is structurally conformable with the underlying Colville group and no large erosional break is indicated by the field data. The rocks here named the Sagavanirktok formation have not been previously mapped or described. They apparently do not crop out west of the Itkillik River and are not definitely known in the Canning River area. Thus the formation lies in an area that was unmapped and unexplored by geologists before 1944

### QUATERNARY ROCKS

#### *Pleistocene*

#### GUBIK FORMATION

The Gubik formation of Pleistocene age mantles the older rocks in much of the Arctic Coastal Plain of northern Alaska. The name Gubik sand was first applied by Schrader<sup>11</sup> to a "surficial deposit of brownish sand or loam about 10 to 15 feet in thickness" which is exposed along the Colville River in the Coastal Plain province. The name is from the Eskimo name of the Colville River. Leffingwell<sup>12</sup> points out that the Eskimo name for the lower river is Kupik or "big river." Gubik, now the accepted spelling, is apparently a misspelling of Kupik.

The Gubik formation, as here redefined, ranges in thickness from a few feet to 150 feet, but in most exposures is 10 to 30 feet thick. It is largely marine and consists predominantly of loosely consolidated, cross-bedded, brown or buff gravel, sand, silt, and clay. The microfauna is somewhat similar to recent faunas and is more diversified than any of the older microfaunas of northern Alaska. The Gubik fauna differs from living Arctic faunas in that no pelagic forms have been found.

The bluffs along the west bank of the Colville River from the mouth of the Anaktuvuk River to Ocean Point expose the Gubik formation lying unconformably on the upper 1,500 feet of the Colville group. This is the original type locality as defined by Schrader<sup>13</sup>. A maximum thickness of 30 feet is exposed along the Colville River, but a thickness of 150 feet has been mapped on the Kikiakrorak River, 15 airline miles upstream from its confluence with the Colville River.

<sup>11</sup> SCHRADER, F. C., op. cit.: 93.

<sup>12</sup> LEFFINGWELL, E. DE K., *The Canning River region, northern Alaska*. U. S. Geol. Surv. Prof. Pap. 109: 95, 109. 1919.

<sup>13</sup> SCHRADER, F. C., op. cit.: 93.

ZOOLOGY.—A new subgenus of *Diaptomus* (Copepoda: Calanoida), including an Asiatic species and a new species from Alaska. MILDRED STRATTON WILSON, Arctic Health Research Center, Public Health Service, Federal Security Agency, Anchorage, Alaska. (Communicated by F. A. Chace, Jr.)

This paper is part of a projected survey of the fresh-water Copepoda of Alaska. It includes the description of a new species of *Diaptomus* that has zoogeographical importance because of its close relationship to one from the Asiatic portion of the U. S. S. R. This latter species (*D. rylovi* Smirnov, 1930) has been assigned by Kiefer (1938a) to his genus *Neurodiaptomus*. Since it and the new Alaskan species exhibit distinct differences from all the other members of this group, a new division is proposed to include them. This is given the status of subgenus, as I agree with Light that the structural range of variation among the species of *Diaptomus* (sensu lato) is not great enough to allow the full rank of genus to most of the subdivisions of the so-called Diaptominae proposed by Kiefer (1932, 1936a-d, 1937, 1938a-b) and himself (1938, 1939).

#### FAMILY DIAPTOMIDAE

##### Genus *Diaptomus* Westwood

The broad definition of *Diaptomus* used here excludes only the species delegated by Kiefer to genera of the Paradiptominae and to *Acanthodiaptomus*, which is characterized by features common to his two subfamilies. Such a definition must include *Hemidiaptomus* Sars, 1903, because it is naturally a part of the large series of subgenera into which it is possible to divide *Diaptomus*. Kiefer's studies have drawn attention to the highly significant, but hitherto largely neglected characters of the left exopod of the male fifth leg. The structure in *Hemidiaptomus* of this and of other appendages of systematic importance, do not depart from the basic patterns found in *Diaptomus*.

One of the remainder of Kiefer's groups, *Psychrodiaptomus* (1938b), is a synonym of *Leptodiaptomus* Light. These names were both proposed in 1938, but the publication date of *Leptodiaptomus*, March 9, precedes that of *Psychrodiaptomus*, April 20.

It is felt that detailed reexamination of many species, particularly of those of North America, is needed before an evaluation of Kiefer's system

of classification is possible. Therefore, a rediagnosis of *Diaptomus* is deferred for the present.

#### Nordodiaptomus, n. subg.

*Subgenotype*.—*Diaptomus siberiensis*, new name for *Diaptomus rylovi* Smirnov, 1930.

*Diagnosis*.—Of moderate size, length of females between 1.6 and 2.4 mm; of males between 1.4 and 1.7 mm. Metasome without bizarre protrusions, the wings of last segment in female only moderately developed; last segment distinct in male. Urosome of female with 3 well-defined segments, the genital a little asymmetrical, the sensilla not grossly developed; urosome of male asymmetrical or not.

Antennules short in both sexes, only reaching to near the end of the metasome; that of the female with a stout, very elongate seta on the first segment, and with segments 11 and 13 to 19 usually with 2 setae. The left antennule of the male differing from that of the female in having the seta of segment 1 not so well developed and only a few of segments 13 to 19 with more than 1 seta. Right antennule of male with the spines of segments 8 and 12 not enlarged, those of 10, 11 and 13 much enlarged, with dissected ends, that of 13 not reaching beyond segment 14; segments 14-16 very tumid, 14 without a process or spine; segments 15-16 with short cuticular processes; the antepenultimate segment without armature of any kind.

Maxilliped not enlarged; the endopod about half the length of the basipod, its setae slender and nonprehensile.

Outer spines of the exopods of legs 1-4 normal, those of leg 1 not at all enlarged. Leg 2 of female lacking the dorsal cuticular lappet (Schmeil's organ) of the second endopod segment; absent or not in the male.

Fifth leg of female with exopod symmetrical, the third segment distinct, its setae and that of the second segment not elongate but very stout and subequal to one another. The endopod usually shorter than the first exopod segment, normally with a single, subapical, more or less well developed spiniform seta. The endopod and its armature symmetrical or not, the whole ramus sometimes subject to considerable variation within a single population.

Fifth leg of male without bizarre armature. The right leg having the apical claw very elongate, its length about equal to that of the rest of the ramus; the lateral spine of exopod 2 stout and near the terminus of the segment; posterior face of exopod 1 with very small but heavy lamellae. Exopod 2 with or without inner cuticular spine. Both pads of the distal segment of the left exopod well defined, about equal in length, the distal narrower than the other, postero-medial in position; the proximal bulging a little medially, and with a narrowed portion extended across the top of the segment on the anterior side; both pads armed conspicuously with slender to stout hairs. The processes closely set, both distally directed; the distal short, its length not more than one-half that of the outer margin of the segment, digitiform, continuous with but more or less demarcated from the segment, with or without spinules on its inner margin; the proximal process a subterminal, stout, curving spine, reaching to the end of the other process or beyond, armed laterally with spinules. Endopods not grossly developed.

Included species: *Diaptomus siberiensis*, n. name; *Diaptomus alaskaensis*, n. sp.

#### *Diaptomus siberiensis*, n. name

*Diaptomus rylovi* Smirnov, 1930, pp. 79-82, fig. 1; 1931, pp. 627-634, figs. 12-21; Kiefer, 1932, p. 478. *Neurodiaptomus rylovi* Kiefer, 1938a, p. 46.

The description given in German by Smirnov (1931) has been largely used in this study. The diagnostic characters of *D. siberiensis* are given herein in the section in which it is compared to the new Alaskan species.

**Occurrence.**—The type locality is a small lake at Bonmak, on the bank of the River Zeya, in the Amur region of southeastern Asiatic U. S. S. R. This is apparently in the area of the head waters of the River Zeya, which according to Berg (1938) lies in the Stanovoy mountain range. Smirnov does not give the altitude, but it appears to be in the secondary southern chain having peaks of relatively low elevation (1,400 meters). The species was also found in a collection from Kjusjur, toward Bulun, which is a little south of the delta of the Lena River on the Arctic coast. This is in tundra area where the subsoil is permanently frozen and superficially at least, represents a contrast to the mountain lake habitat of the Amur locality.

**Variation.**—Smirnov mentioned no variation

in the specimens from the type locality, except for the division of the claw of the fifth leg in some males. In the Lena River specimens, the male was wholly typical, but the female was much smaller in size, 1.7 mm as opposed to the 2.4 mm of the Amur specimens, and had only one seta instead of two on the thirteenth segment of the antennule. The endopod of the fifth leg differed in being shorter, and in having its first segment longer than the second. No statement was made as to whether these variations characterized a single individual or several.

**Nomenclature.**—The specific name *rylovi* was used by Charin (1928) for a species of *Hemidiaptomus*. As pointed out above, this group exhibits no differences from other groups of *Diaptomus* sufficiently distinct enough to warrant other than subgeneric status; Charin's species should therefore be known as *Diaptomus (Hemidiaptomus) rylovi*. This necessitates the renaming of Smirnov's species; the name *siberiensis* is proposed as a geographic contrast to that of the related Alaskan species.

#### *Diaptomus alaskaensis*, n. sp.

Figs. 1-29

**Specimens examined.**—30 ♀ ♂, collected in a mountain top pool, Eagle Summit, on the Steese Highway between Fairbanks and Circle, Alaska; elevation 3,880 feet; July 4, 1947. Collector, Charles S. Wilson.

**Types.**—In the United States National Museum. Holotype male, no. 90711; allotype female, no. 90712.

**Description.**—Length of preserved specimens, middorsal line, female, about 1.65 mm; male, about 1.44 mm.

#### FEMALE

**Metasome** (Fig. 7).—Approximately twice the length of the urosome in middorsal line. In dorsal view, the greatest width occurring just behind the cephalic suture, tapering from there to the beginning of the second segment, beyond that of rather uniform width to the wings of the last segment which are a little expanded. The cephalic segment a little longer than segments 2-4 combined (proportions approximately 37:32); its suture distinct; the anterior portion roughly triangular in dorsal view. The last segment imperfectly separated by a short lateral suture, the wings well rounded at the sides, reaching posteriorly to about the middle of the

genital segment; the tips only slightly drawn out, the asymmetry not distinctly pronounced. Each side armed with two types of sensilla, that of the wing tip a small peglike seta; the other a shorter seta set on a small rounded tubercle and arising on the inner rounded portion of the wing (Fig. 10). The marginal hyaline area of the wing (demarcated in Fig. 11 by dotted lines) very narrow.

*Urosome* (Fig. 11).—All three segments distinct. Genital segment not markedly inflated, but noticeably asymmetrical; the left side with a gently rounding lobe above the middle; the anterior half of the right side produced into a large backwardly directed lobe, behind which laterally is another narrowly rounded area. Each side armed on the anterior lobe with a sensillum very like that of the inner lobe of the thoracic wing. The rest of the urosome symmetrical; the third segment longer than the second (proportions about 3:2); the caudal rami only a little longer than the third segment, their length about twice their greatest width; with hairs on the inner margins from near the proximal portion to the tip; caudal setae normal.

Most females of the sample were ovigerous; the eggs comparatively large and few in number (6 to 10).

*Rostral filaments* (Fig. 8) attenuated and very slender.

*Antennule* (Fig. 5).—Comparatively short, reaching to near the tips of the thoracic wings. The elongate seta of segment 1 (measured from its base) reaching to between the end of segment 11 and the middle of segment 12; very stout basally and throughout much of its length, arising from a well defined and large cuticular base. (In Fig. 5 for convenience in arrangement of drawings, this seta has been "pulled in" towards the body of the antennule; in all the preserved specimens, both before and after dissection, it is held out more or less perpendicular to the segment; the stoutness of the proximal portion suggests that this is the natural position in life.)

The number of setae on segments 1-10, 12 and 20-25 as usual: 3 on segment 2, 2 on 9 and 22-23, 5 on 25, 1 on the others. Segments 11 and 13-19 with 2 setae each. Aesthetes normal in distribution.

*Maxilliped* (Fig. 6).—First basal segment with all 4 lobes well developed, their setation normal; the distal seta of lobes 2-3 much longer than the others accompanying it, subequal to each other

and to that of lobe 1; the four setae of the extended distal lobe all shorter than the longest seta of lobes 1-3, the proximal the shortest, the others subequal. Second basal segment a little shorter than segment 1, its distal seta the longer, about equal to the longest setae of lobes 1-3 of the second segment. The partially suppressed segment bearing two setae. The endopod about as long as basal segment 2, of five distinct segments, all of its setae slender and setiform, those of the inner side all shorter than the 3 terminal outer setae of the apical segment.

*Leg 1* (Fig. 4).—The ventral surface of basipod 2 with a patch of long fine hairs on its outer portion just above the exopod, the remainder unarmed. Outer spines of exopod segments 1 and 3 only moderately stout; subequal to one another, that of segment 3 being only a little longer than that of 1 (approximate proportions 11:10); both tipped apically with a very slender sensory hair; their marginal spinules minute (see detail, Fig. 4), hardly distinguishable except at very high magnification. The spine of segment 1 reaching only to about the middle of the second segment, bent, with a resultant inner marginal notch proximally.

The elongate terminal spinelike seta of segment 3 stout, broader basally than the outer spine, its inner margin indented, bearing fine marginal hairs below the point of indentation; the outer margin, beginning at a corresponding point, armed with a very narrow, finely serrate flange (see detail, Fig. 4). The other setae of the segment all reaching considerably beyond the apex of this outer seta (proportional lengths, about 70:54). The outer margins of the exopod segments without hairs.

*Leg 2*.—The second segment of the endopod lacking a cuticular lobe on the dorsal face.

*Leg 5* (Figs. 1 and 2).—The posterior side of the first basal segment tumid; the sensillum short and spinelike, mounted on a small tubercle. Second basal segment not tumid, considerably prolonged on the anteromedial side to the point of attachment of the endopod (Fig. 2); no sensory hair apparent, a cuticular depression observed in the place of its normal location on one specimen.

The exopod (to tip of claw) only a little longer along its inner margin than the basipod. The inner margin of the first segment roughly about two-thirds of the length of the outer (proportions 25:35); its width about three-fourths of the length of the inner and about one-half of that

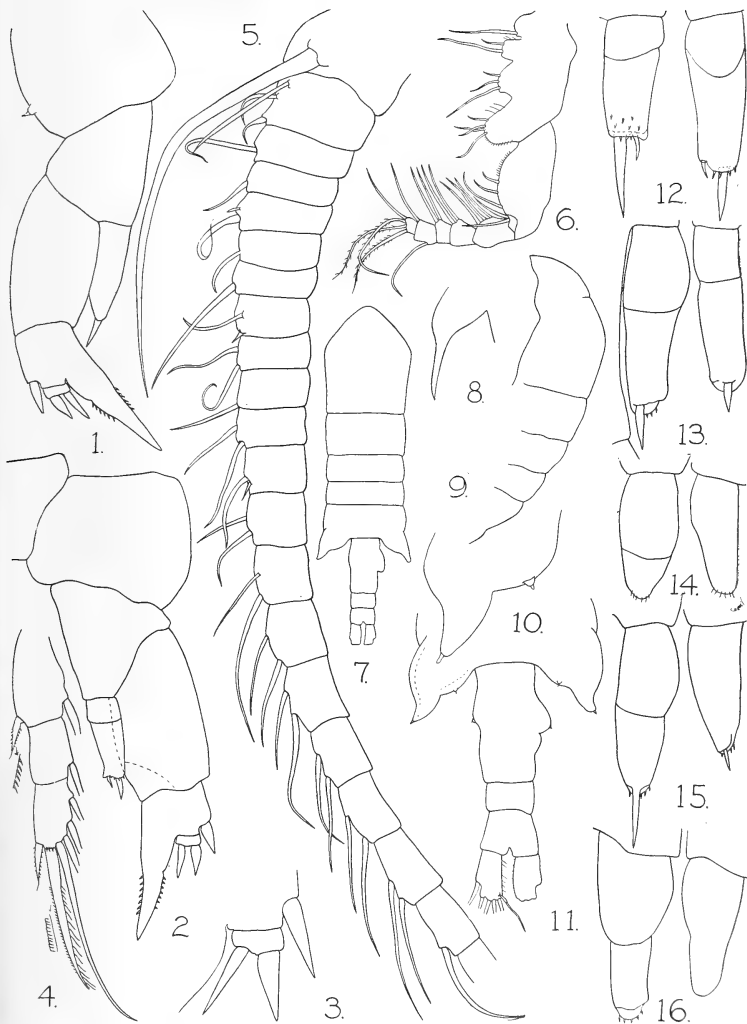

FIGS. 1-16.—*Diaptomus alaskaensis*, n. sp., female

1-3, Leg 5: 1, Left side, posterior view, specimen no. 7; 2, left, anterior view, specimen no. 2; 3, exopod setae, specimen no. 5. 4, Leg 1, exopod. 5, Antennule, segments 1-20. 6, Maxilliped. 7, Dorsal outline of body. 8, Rostral filament. 9, Lateral outline of body. 10, Detail metasome and sensilla. 11, Last metasome segment and urosome. 12-16, Leg 5, endopods: 12, Specimen no. 2, anterior view; 13, specimen no. 6, posterior; 14, specimen no. 8, posterior; 15, specimen no. 7, posterior; 16, specimen no. 3, posterior.

of the outer margin. The inner margin of the second segment (to tip of claw) a little shorter than the outer margin of the first segment (32:35), about one-third longer than the inner margin; its greatest width a little less than one-half its length. Claw moderately stout, curving inwards on both margins a little above the middle, with a distinct notch on the outer margin; armed on both sides with 6-10 spinules; some specimens showing a faint crosswise line of division at the position of the notch. Lateral seta stout and spiniform, unarmed, a little more than half the length of the outer margin of the segment.

Third segment (Fig. 3) distinct, short and broad, its width almost twice the length of its outer margin which is a little longer than the inner. The outer seta similar in length and stoutness to that of the second segment, the inner more slender and a little longer; both unornamented.

The endopods of a pair asymmetrical in length and in armature; showing extreme variability within the available sample. Usually 2-segmented and shorter than the first exopod segment; unarmed terminally or with a short spiniform seta.

*Variation in leg 5.*—Measurements of eight specimens showed slight differences in the proportional lengths and widths of the exopod. The greater number attained that shown in Fig. 1, in which the inner margin of exopod 2 (to tip of claw) is subequal to the outer margin of the first segment and about one-third longer than the inner. Two specimens had the inner margin of segment 2 proportionally a little shorter (Fig. 2), and in one specimen they were a little longer, approaching *D. siberiensis*.

The widths of exopod 1 and 2 in diptomids are never precisely measurable, but even with allowances made for the differences in position and flattening of the mounted appendages by the cover slip, it is apparent that the specimens with the shorter claws (the inner margin of exopod 2) are also proportionally broader in both segments 1 and 2.

So far as could be judged, no significant difference was apparent in the relative length and width of the third exopod segment. There is some slight difference in the proportional strength of the setae from specimen to specimen, but the relation of the two to each other is rather constant.

The endopod is extremely variable, differing

in each of the specimens studied. The differences are shown in Figs. 12 to 16, and in Table 1, where the total length is also compared to the length of the inner margin of the exopod. Of the eight examined, four have a terminal spiniform seta; one of these differs from the others in having in addition a small abortive seta (Fig. 12). The endopods also show an unusual asymmetry. This is evident in the relative lengths of the right and left ramus of a pair, the left being always the longer; this difference considerable in some specimens (Table 1, nos. 4 and 7); negligible in others (nos. 1 and 8). The asymmetry is further expressed in the relative lengths of the terminal setae, that of one side always longer than that of the other (Figs. 13 and 15). The spinule pattern of the terminal portions also differs (Figs. 12 and 16).

Variability in the endopod of the female in *Diptomus* is not at all rare, but it is more commonly expressed in differences in segmentation, and small differences in proportional length of the endopod to the exopod. In subgenera in which 2 setae are normally present, one may sometimes be lacking. In general, the endopod is much more variable in the males of the genus, but in this species the opposite is true. As noted above, Smirnov found a geographical variation in the female of *D. siberiensis*. We do not, of course, know how variable that species is, as he gives no indication of whether he found the condition illustrated in Fig. 15 (Smirnov, 1931) to be true of one or several specimens. Actual comparisons between the two species as regards this variability is therefore not now possible.

The asymmetry of the endopod, as of the rest of the appendage, is an invariable rule in the male diptomid, but it is usually not expressed in the other sex. Only in recent years has such a condition been noted in the fifth legs of females of certain south Asiatic groups (*Allodiptomus* Kiefer, 1936a-b, *Mongolodiptomus* Kiefer, 1937, 1938a) and some South American species (*D. azevedoi* Wright 1935, *D. paulistanus* Wright, 1937). Though this asymmetry appears to be a well established character, it may also be that in some cases so few specimens of a given species have been examined that what is actually anomalous has been described as normal. For my part, I should like to reserve judgment on the condition in *D. alaskaensis* until more individuals from both the type and other localities in which it may occur are available for study.



## MALE

*Metasome*.—About one and a half times the length of the urosome. More slender than the female, the greatest width in dorsal view occurring at the middle of the cephalic segment, from there the whole body tapering gradually to the terminal part. The anterior portion of the cephalic segment somewhat narrowed, the rather broad triangular appearance of the female only indistinctly suggested. The last segment separated, its lateral tips not drawn out, but asymmetrical (Fig. 21), the left side straight, the right angular, its distal half directed inwards; each side armed at the lateral tip with a single sensillum, very small and spiniform, mounted on a tubercle having rather straight sides (Fig. 20), the tubercle of the right a little larger than that of the left side of the segment. The hyaline area as demarcated in Fig. 20.

*Urosome* (Fig. 21).—Not conspicuously asymmetrical. The genital segment with the right side a little inflated and irregular in outline; the left side with the lateral slit conspicuous, the backwardly produced proximal lobe not covering it; neither side with apparent sensillum. Segment 4 a little longer on the right than the left side, the other segments symmetrical. Caudal rami normal, with the inner margins hairy.

*Rostral filaments*.—Relatively as long as those of the female, but a little stouter throughout most of their length.

*Antennule*.—The right reaching to the end of the second urosomal segment, the left a little shorter; both relatively longer than those of the female. The left (Fig. 17) differing also from that of the female in having the seta of segment 1 not so enlarged or lengthened; stretched out it reaches from its base only to about the middle of the fourth segment. Setae of the second segment also unlike those of the female. The setal pattern differing in that only segments 11, 16 and 19 of the midportion of the antennule have 2 setae; the others with one each. In addition to that of segment 1, rather long setae found on segments 7, 9, and 14. Those of 7 and 9 subequal and a little longer than those of 1 and 14 which are also subequal to each other. The approximate proportions of these setae to one another are:

segment 1—41      segment 7—55  
segment 14—40    segment 9—54

Aesthetes of normal distribution as in female.

The right antennule with segments 14–16 conspicuously swollen (Fig. 18). Spines of 8 and 12 not enlarged; those of segments 10–11 and 13 very stout; that of 10 not as long as the width of its segment; that of 11 longer, reaching to the middle of segment 13; that of 13 strongly bent distad, incompletely demarcated from the segment, a little stouter but scarcely longer than that of 11, reaching to the middle of segment 14; the tips of all 3 spines dissected as indicated in figure 19. Segments 15–16 each with short cuticular processes of similar size; modified setae, with subterminal lateral tongue-like processes (Fig. 18), accompanying them and the depressed process of segment 17, all subequal to one another. Antepenultimate segment without process or lamella. Setae of terminal segment all weakly developed.

*Maxilliped and leg 1* as in female. *Leg 2* also lacking a cuticular lobe on the dorsal face of the second segment of the endopod.

*Leg 5* (Figs. 22–23).—The left leg a little more slender than that of the right side; reaching almost to the end of its second exopod segment.

*Right leg*: The outer portion of the first basal segment very tumid, overhanging the second segment considerably on the postero-lateral side; the inner side also expanded with a large distally directed hyaline lamella on the anterior face (Fig. 22); the sensillum a seta without apparent tubercular base, in a distal medial position on the dorsal side. The outer margin of the second

TABLE 1.—COMPARISON OF THE ENDOPODS OF LEG 5 IN EIGHT PARATYPE FEMALES OF *DIAPTOMUS ALASKAENSIS*

Specimen No.	Exopod I inner margin	Right endopod			Left endopod		
		Total length	Number of segments	Armature	Total length	Number of segments	Armature
1	78 $\mu$	39 $\mu$	2	Spinules	42 $\mu$	2	Spinules
2	75	45	2	2 setae + spinules	57	2	2 setae + spinules
3	81	45	1	None	57	2	Spinules
4	81	42	2	Spinules	60	2	Spinules
5	75	36	2	None	45	2	Spinules
6	75	54	2	1 seta + spinules	66	2	1 seta + spinules
7	69	42	2	1 seta + spinules	57	2	1 seta + spinules
8	60	42	1	Terminal hairs	45	1	Terminal hairs

basal segment rounded, the hair at the distal fourth; the inner margin a little longer than the outer, prolonged a little to the point of attachment of the endopod; the medial portion somewhat expanded and having attached to its posterior face a hyaline membranous lamella that bulges upward.

Exopod (exclusive of claw) subequal in length to the basipod. The first segment having the length of its outer margin greater than that of the inner (proportions about 27:17) and about equal to its greatest width; ending in a distally directed, rounded lobe; on the posterior face, near the extreme distal margin, two small, rather heavily chitinized lamellae (Fig. 24), that near the outer edge V-shaped, the other having a thick, pointed edge that is produced a little beyond the inner distal corner of the segment and extended more or less toward the other as a bar. The second segment with both margins nearly straight; the inner a little less than twice the greatest width (relative proportions 40:25); the outer curving inwardly at the point of attachment of the lateral spine; the inner distal edge membranous and somewhat crenulated. This segment bearing the characteristically rounded, small, heavy lamella on the proximal inner edge of the posterior side; somewhat distad to this and very near the margin, a minute and thin cuticular spine. Lateral spine near the terminus of the segment, stout and long, a little longer than the outer margin of the segment above its base, coarsely dentate on its inner edge. Claw very long, its length about equal to that of the ramus, strongly curved beyond its middle, enlarged at its base, with a small tubercle on the anterior side (Fig. 22), dentate below this bulbous enlargement to near the tip; in some specimens a fine division into two parts noticeable near the middle of the claw.

Endopod a little shorter than the inner margin of the first segment of the exopod; 2-segmented, the first broadened basally and only about half the length of the distal segment.

Left leg: The first basal segment not expanded on the outer margin, but extended inwardly to a well rounded lamelliform edge; sensillum a minute, curved spinule, mounted on a small tubercle. The second segment having its outer margin shorter than the inner, concave at its center; the sensory hair at the distal fifth; the inner distal margin considerably prolonged medially to the point of attachment of the endopod; a

distinct jog in its margin just in front of the middle.

Exopod narrowed to about half the width of the basipod, its length along the outer margin somewhat less (about one-sixth). The first segment about two-thirds of the total length, provided on its anterior inner side (Fig. 25) with a narrow flattened pad armed with very short fine hairs. Both pads of the distal segment in a medial position, the proximal the more tumid, bulging a little on the anterior side with a narrowed portion carried across the proximal part of the segment so that it appears to fit tightly into the segmental suture (Fig. 26); on the posterior side only a small lengthwise portion of the pad visible (Figs. 27-28); armed with fine hairs that are longer than those of the pad of the first segment. The distal pad reduced in breadth, largely postero-medial in position, distally not reaching to the base of the terminal process; its apical portion sagging somewhat and forming a notch with the main body of the segment, as visible in posterior profile (Fig. 27); pad set with very short, stout hairs. On the margin of the segment between the apex of the pad and the inner base of the terminal process there may be 1-3 minute spinules, but these not always present.

The processes of the distal segment closely set (Fig. 29). The digitiform distal process demarcated from the segment, its length a little less than one-third that of the outer margin of the segment; very broad throughout most of its length, but its tip slightly drawn out; its inner margin without teeth. The proximal process spiniform, curving toward the terminal process and reaching to its apex or a very little beyond it; attached on the anterior side of the segment, distally directed; a little enlarged basally, the width at its middle about one-third that of the distal process; with coarse teeth on its inner margin, and a similar row on the posterior side near its outer edge.

Endopod reaching a little beyond the first exopod segment, 2-segmented, the distal segment about one-third the length of the other, with a few fine hairs on the apex.

#### COMPARISON OF *D. SIBERIENSIS* AND *D. ALASKAENSIS*

Smirnov's description of *D. siberiensis* is precise and detailed so that a fairly exact comparison of the two species can be made.

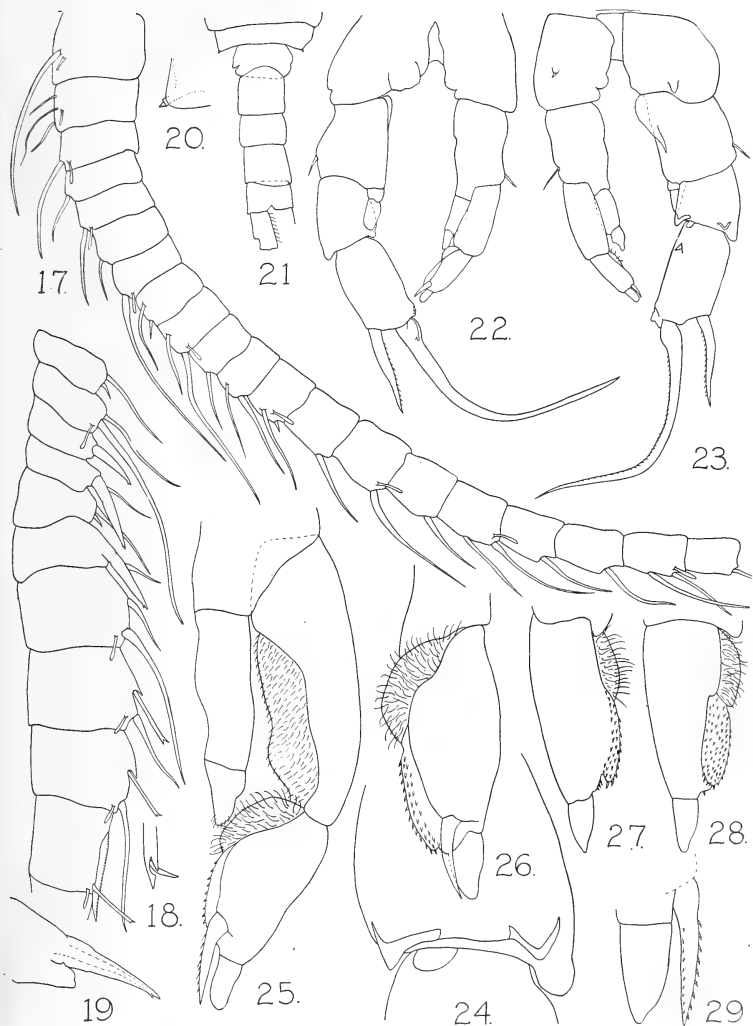

FIGS. 17-29.—*Diaptomus alaskaensis*, n. sp., male

17, Left antennule, segments 1-20. 18, Right antennule, segments 8-17, with detail of modified seta. 19, Right antennule, segment 13. 20, Detail, left metasome wing. 21, Last metasome segment and urosome. 22-29, Leg 5: 22, Anterior view; 23, posterior view; 24, detail lamellae, right exopod; 25, left exopod and endopod, anterior; 26, detail exopod 2, anteromedial view; 27, exopod 2, posterior; 28, exopod 2, posteromedial view; 29, exopod 2, detail of processes, posterior view.

He did not describe the maxilliped or leg 1, and the characters of these appendages given in the subgeneric diagnosis are from *D. alaskaensis*. No basic differences can be expected to occur in two such closely related species, so that only knowledge of minor specific differences is lacking for these appendages.

The resemblance between the two species is great. They appear to have the same general body form; the antennules of the females are alike; there is no apparent difference in the right antennules of the males, though those of the left side differ in the setation of some segments. Comparison of the fifth legs of the females is difficult because of the great variability found in certain characters of *D. alaskaensis*, and because it cannot be told whether or not those of *D. siberiensis* are also extremely variable. The form of the appendage is similar in the two species, and the setae of the second and third segments of the exopod are alike; certain differences which may be well defined and stable are discussed below. The male fifth legs are strikingly similar in general appearance, in the relative lengths of the two rami, and of the claw and lateral spine of the right exopod, in the form of the lamellae of the right leg, and in the arrangement and form of the pads of the left exopod. Careful observation shows some well-defined differences which coupled with the setation of the left antennule, were constant in the available sample of *D. alaskaensis*. Smirnov found that the characters of the male of *D. siberiensis* did not vary geographically, and this makes it appear that the males are not subject to the same variation that affects the females of the subgenus.

The two species have been herein separated on the basis of the following important differences which appear to be characters of stability, and are apparently carefully described by Smirnov for *D. siberiensis*, so that comparison is possible:

*Rostral filaments* short and stout in *siberiensis*; slender and attenuated in *alaskaensis*.

*Left antennule of male* with 2 setae on segments 11 and 18 in *siberiensis*; with 2 setae on segments 11, 16 and 19 in *alaskaensis*.

*Leg 2* with a cuticular lappet on segment 2 of

the endopod of the male in *siberiensis*; lacking in both sexes in *alaskaensis*.

*Urosome of female* having the genital segment in *siberiensis* apparently less produced on the right side than that of *alaskaensis* and with segments 2 and 3 equal in length; in *alaskaensis* segment 2 is much shorter than segment 3.

*Urosome of male in siberiensis* is wholly symmetrical; in *alaskaensis* segments 1 and 4 are a little asymmetrical.

*Leg 5 of female* has two measurable characters that appear to vary but little in *alaskaensis* and are sufficiently different from *siberiensis*, as shown by Smirnov's drawing (1931, fig. 15) to permit relative comparison and separation of the two species. In *siberiensis* the inner margin of the second exopod segment (including the "claw") is apparently longer than the outer margin of the first segment; in *alaskaensis* it was usually found to be shorter. A more important difference lies in the third exopod segment, which, if correctly delineated by Smirnov, is as wide as it is long in *siberiensis*; its width in *alaskaensis* is about twice its length. Other differences which may or may not be real, lie in the greater slenderness of the appendage in *siberiensis*, the larger number of spinules on the "claw", the lack of much variability in the endopod, absence of asymmetry in the length and armature of a pair, and the stouter development of its single, apical seta.

*Leg 5 of male. Right side:* In *siberiensis* the first exopod segment has its outer margin only a little longer than its inner and greater than its width; in *alaskaensis* it is considerably longer than that of the inner and equal to its width; the armature of this segment appears to be very similar in form, but the lamellae of *siberiensis* are both placed above the distal margin of the segment, while those of *alaskaensis* are very close to it, so that of the inner edge is produced beyond the corner of the segment. The second exopod segment of *siberiensis* lacks a cuticular spine which is present in *alaskaensis*. *Left side:* In *siberiensis* the proximal process of the terminal segment reaches considerably beyond the end of the distal process; in *alaskaensis* this process reaches to the end of the distal process, or at most a very little beyond it; the distal process of *siberiensis* is armed on the inner margin with a few spinules; that of *alaskaensis* is unarmed. The distal pad of *siberiensis* appears to be a little more developed than that of *alaskaensis*, and is armed with slender instead of thick, short hairs.

DISTINCTIONS BETWEEN NORDODIAPTOMUS  
AND NEUTRODIAPTOMUS

Kiefer (1932) placed *D. siberiensis* in a list of species that he could not assign to any of his newly erected genera; in 1938 he referred it to *Neurodiaptomus*. It is therefore necessary to compare the characters of this subgenus with *Nordodiaptomus*.

In establishing *Neurodiaptomus* in 1937, Kiefer included the species *tumidus* Kiefer, *pachypoditus* Rylov, *amurensis* Rylov, and *mariadvigae* Brehm. To these he added (1938a) *incongruens* Poppe, *siberiensis* (as *D. rylovi* Smirnov), and *lobatus* Lilljeborg, the synonymy of the latter with *incongruens* appearing to him to be an uncertain matter. Hu (1943) described a new species *alatus*.

Of these species, *D. siberiensis* and *D. mariadvigae* appear to differ sharply from the consistently developed characters that hold the others together. *D. siberiensis* has been referred above to the new subgenus *Nordodiaptomus*. *D. mariadvigae* is apparently closely related to, if not conspecific with, the species *hsichouensis* recently described by Hsiao (1950). This species occurs in Yunnan, the same Chinese province in which Brehm's collection was made (Brehm, 1921, 1930). Hsiao considers that the lack of terminal setae on the endopod of the fifth leg of the female and the "pincerlike" structure of the processes of the left male fifth leg, though reduced in length, indicate relationship to *Arctodiaptomus*. He therefore made his new species the type of a subgenus *Pararctodiaptomus*. In the definition of *Diaptomus* used here, *Arctodiaptomus* is considered as a subgenus; the status of the various subgroups that have been proposed for it can be evaluated only when the whole of this subgenus is reinvestigated. It is possible that *Pararctodiaptomus* may be found to be of separate subgeneric status within the genus *Diaptomus*. This is particularly so if the distal pad of the male left fifth exopod is as well developed as is suggested by Hsiao's illustration; its loss or extreme reduction is highly characteristic of *Arctodiaptomus*.

So far as it is possible to ascertain from published descriptions, the remaining species of *Neurodiaptomus* agree with one another very closely in several significant characters. From these, the species of *Nordodiaptomus* depart rather noticeably. Though agreeing in certain patterns,

these two subgenera are naturally set apart by these differences. A brief comparison makes this clear.

The female fifth leg of *Neurodiaptomus* has two short, equally developed setae on the terminus of the endopod; the pattern of the setae of exopod segments 2 and 3, identical in all the species, consists of a minute seta on 2, while on 3 there are a similar small outer and a much longer inner seta. *Nordodiaptomus* with the single spinelike seta of the endopod, and the stout, subequal setae of the exopod, is in sharp contrast. Indeed, these differences are among the most significant in separating the two groups, particularly the structure of the exopod setae which in *Nordodiaptomus* are of uncommon form for the whole genus.

The male right antennule has the pattern of segments 13-15 similar in both groups, but the spines of 10 and 11 are very short in *Neurodiaptomus*, while they are of considerable stoutness in *Nordodiaptomus*; all species of *Neurodiaptomus* have a hyaline lamella on the antepenultimate segment, in *Nordodiaptomus* this segment is unarmed. While these are characters that may vary within a group of related species, apparently their nonvariability may also distinguish a subgenus. This last seems especially true in *Neurodiaptomus*; in our present knowledge there are no intermediate forms between it and *Nordodiaptomus*.

In the male right fifth leg of *Neurodiaptomus*, the apical claw is never longer than the exopod, and the lateral spine, located at the proximal to the distal third, is usually less than the width of its segment. Both are of exceptional stoutness and length in *Nordodiaptomus*.

Any comparison between the patterns of the terminal segment of the left exopods is not wholly satisfactory because of the incompleteness of the descriptions of *Neurodiaptomus*. The only enlarged drawings in literature are those of *tumidus* (Kiefer, 1938a) and *amurensis* (Rylov, 1930), and of these only *tumidus* is well enough described verbally to permit real comparison. The similarities of the two groups are: both pads are well defined and subequal to one another; the terminal process is short and digitiform; the proximal process is subterminal in position and about equal to or reaching a little beyond the distal. The differences between the two groups are more difficult to define; where it is possible to compare, the following are suggested.

The proximal pad in *Nordodiptomus* is not merely a medially bulging structure, but is carried well across the anterior side of the segment and its shape is thus distinctly asymmetrical; it appears as a simple, medially placed pad in *Neurodiptomus*. The distal pad is conspicuously armed with slender to short, stout hairs in *Nordodiptomus*; in *Neurodiptomus* there may be little or no armature of this pad. Kiefer (1938a) has described that of *tumidus* as a "lobus" and shows no ornamentation, as is also true of Rylov's (1930) figure of *amurensis*.

The proximal process of *Nordodiptomus* is stout and spiniform; Smirnov describes that of *siberiensis* as a "spine" and my observations in *alaskaensis* confirm this. Kiefer speaks of those of *tumidus* and *pachypoditus* as "setae" and his illustrations picture this process as exceedingly slender. The difference between seta and spine is undoubtedly one of degree and is not always easy to determine. In this case it may merely be one of interpretation. The degree of stoutness and the form of this process, however, distinguishes other subgenera of *Diaptomus*, and it is necessary in the absence of any other evidence, to consider that these two groups are separable by the spiniform character of this process in *Nordodiptomus* as opposed to its setiform development in *Neurodiptomus*.

It is unfortunate that for the species of *Neurodiptomus* no information is available concerning the highly important details of the maxilliped, the first leg, the cuticular process of the endopod of the second leg, the setation of the female antennule and its comparison to the male left antennule. Until taxonomists also include information about these points in their descriptions of diaptomid copepods, we will not be able to arrive at any satisfactory comparison of species or of subgenera. My study of North American species suggests that the development of the maxilliped, particularly of the setae of the endopod, the characters of the first leg, the presence or absence of Schmeil's organ on the endopod of the second leg, and the setation of the female antennule, are often as characteristic of subgenera as the modifications of the left exopod of the male fifth leg or the terminal setae of the endopod of the female fifth leg. They are in any case a part of the whole picture, and must be considered before any comprehensive evaluation

of subgeneric or generic characters can be made.

In addition to its distinctions from *Neurodiptomus*, *Nordodiptomus* departs in some characters from the usual condition found in *Diaptomus*. One such instance is that Schmeil's organ may be either present or absent, and interestingly is exhibited as a case of sexual dimorphism in one species. The numerical difference in setation of the antennules of the female and that of the left side of the male is the only one known to me in literature or in fact; investigation may show it to be more common than suspected. The contrast in the size of the setae of the first and second segments is not confined to *Nordodiptomus*; Smirnov (1928) has noted the same sexual dimorphism in *D. (Arctodiptomus) dentifer* which has a similarly elongate seta on segment 1 of the female. The structure of the exopod setae of the female fifth leg in *Neurodiptomus* is common throughout the genus; that of *Nordodiptomus*, as suggested, is rather unusual. The asymmetry of the endopod of *Nordodiptomus alaskaensis* is likewise a rare condition, impossible now to evaluate.

It thus appears that there occur in the two species of *Nordodiptomus*, characters that differ naturally from consistently developed structures in *Neurodiptomus*, and in addition, that they have certain distinctive features which set them apart from other subgenera of *Diaptomus*. The inclusion of the two species in *Neurodiptomus* could be only provisional and would make the definition of that subgenus ambiguous in many parts. It seems best in my judgment to delimit the two groups as has been done herein.

It is probable that these two subgenera may be safely assumed to be closely related. This cannot now be proved, however, due to our lack of complete knowledge of some structures of *Neurodiptomus*, and our present inability to evaluate characters as subgeneric or otherwise.

The species of *Neurodiptomus* extend from subarctic into southeastern Asia. *Nordodiptomus* is in our present knowledge limited to Arctic and subarctic regions of Asia and North America. The discovery of an Alaskan species closely related to one from the Asiatic U. S. S. R. adds to the growing list of examples that disprove the old concept that North American diaptomids are distinct from those of Eurasia. It is to be expected that further study of Alaskan collections will increase the number.

## LITERATURE CITED

- BERG, L. S. *Natural regions of the U. S. S. R.*, ed. 2. 1938. (Translation by Olga Adler Titelbaum, 1950.)
- BREHM, VINCENT. *Diagnosen neue Entomostraken. I. Teil.* Anz. Akad. Wiss. Wien. **58**: 194-196. 1921.
- . *Über südasiatische Diptomiden.* Arch. für Hydrobiol. **22**: 140-161, 14 figs., 1 map. 1930.
- CHARIN, N. N. *Über eine neue Hemidiaptomus-Art aus dem Gouvernement Woronesch.* Zool. Anz. **76**: 323-328, 6 figs. 1928.
- HSIAO, SIDNEY C. *Copepods from Lake Erh Hai, China.* Proc. U. S. Nat. Mus. **100**: 161-200, figs. 20-30. 1950.
- HU, Y. T. *Notes on fresh-water copepods from Pehpei, Szechwan.* Sinensia **14**: 115-128, figs. A-C. 1943.
- KIEFER, FRIEDRICH. *Versuch eines systems der Diptomiden (Copepoda Calanoida).* Zool. Jahrb. (Abt. Syst.) **63**: 451-520, 88 figs. 1932.
- . *Indische Ruderfusskrebse (Crustacea Copepoda).* Zool. Anz. **113**: 136-142, 11 figs. 1936a.
- . *Indische Ruderfusskrebse (Crustacea Copepoda). III.* Zool. Anz. **113**: 321-325, 17 figs. 1936b.
- . *Indische Ruderfusskrebse (Crustacea Copepoda). IV.* Zool. Anz. **114**: 77-82, 14 figs. 1936c.
- . *Über die systematik der südamerikanischen Diptomiden (Crustacea Copepoda).* Zool. Anz. **116**: 194-200. 1936d.
- . *Süsswassercopepoden aus Ostasien. II. Neue Diptomiden und Cyclopiden von der Insel Formosa.* Zool. Anz. **119**: 58-64, 17 figs. 1937.
- . *Freilebende Ruderfusskrebse (Crustacea Copepoda) von Formosa.* Bull. Biogeogr. Soc. Japan. **8**: 35-73, 38 figs. 1938a.
- . *Freilebende Süsswassercopepoden von den Nordkurilen.* Bull. Biogeogr. Soc. Japan. **8**: 75-94, 30 figs. 1938b.
- LIGHT, S. F. *New subgenera and species of diaptomid copepods from the inland waters of California and Nevada.* Univ. California Publ. Zool. **43**: 67-78, 23 figs. 1938.
- . *New American subgenera of Diaptomus Westwood (Copepoda, Calanoida).* Trans. Amer. Micr. Soc. **58**: 473-484, 24 figs. 1939.
- RYLOV, W. M. *The fresh-water calanoids of the U. S. S. R.* In: "Keys to Determination of Fresh-water Organisms of the U. S. S. R.: A, Fresh-Water Fauna.: Pt. I": 1-288, 88 figs. 1930.
- SARS, GEORG OSSIAN. *On the Crustacean fauna of Central Asia. Pt. III. Copepoda and Ostracoda.* Ann. Mus. Zool. Acad. Imper. Sci. St.-Petersbourg **8**: 195-232, pls. 9-16. 1903.
- SMIRNOV, S. S. *Über eine neue Diptomus-Art (Copepoda) aus Zentralrussland.* Zool. Anz. **78**: 27-34, 11 figs. 1928.
- . *Sur une espèce nouvelle du genre Diptomus Westw. (Crustacea, Copepoda), provenant de la région de l'Amour.* Comptes Rendus Acad. Sci. U. S. S. R. for 1930: 79-82, 1 fig. 1930.
- . *Ein Beitrag zur Copepoden-Fauna des Amur-Gebietes.* Arch. für Hydrobiol. **23**: 618-638, 21 figs. 1931.
- WRIGHT, STILLMAN. *Three new species of Diptomus from northeast Brazil.* Ann. Acad. Brasil Sci. **7**: 213-233, pls. 1-4. 1935.
- . *A review of some species of Diptomus from São Paulo.* Ann. Acad. Brasil Sci. **9**: 65-82, pl. 1-3. 1937.

HELMINTHOLOGY.—*A new roundworm, Nematodirus rufaevastitatis (Nematoda: Trichostrongylidae) from domestic sheep, Ovis aries, in Wyoming.* CHARLES G. DURBIN, U. S. Bureau of Animal Industry, and RALPH F. HONESS, University of Wyoming. (Communicated by E. W. Price.)

The nematodes described in this paper were collected by one of the writers (R. F. H.) from domestic sheep in the area of the Red Desert, Wyo., and western Wyoming during 1948 and 1949. The specimens were forwarded for identification to the Zoological Division, Bureau of Animal Industry. A study of them by the senior writer shows that they belong to the genus *Nematodirus*. They differ, however, from the known species of the genus in certain characters and they are, therefore, described as new.

*Nematodirus rufaevastitatis*, n. sp.

*Description.*—MALE: 11.5 to 15.3 mm long and about 0.1 mm wide just anterior to the bursa. Esophagus 0.430 to 0.500 mm long and about

0.030 to 0.040 mm wide at its base. Head 0.025 to 0.030 mm wide, as measured with the cuticle slightly inflated (Fig. 1, A). Spicules 1.0 to 1.15 mm long and united for about the posterior two-thirds of their total length; the tips have a slight membranous inflation (Fig. 1, B). The bursa consists of two large lateral lobes and a dorsal lobe which is indicated only by a slight indentation of the margin of the bursa lateral to the dorsal ray. The length of the bursa from its base to tip is 0.25 to 0.34 mm. Each lateral lobe of bursa is supported by six rays, two ventral, three lateral, and one externodorsal (Fig. 1, C, D). The two ventral rays arise from a common trunk and are long and slender. The three lateral rays likewise arise from a common trunk and are also long and slender. The mediolateral and postero-

lateral rays are close together. The external branch curves ventrally away from the other two branches. The two dorsal rays arise separately. The externodorsal ray is long and very slender when compared with the other rays of the bursa. The dorsal ray is shorter and thicker than the externodorsal ray; the tip of the dorsal ray is not bifid as in the other described species of the genus.

*Female:* Unknown.

*Host:* *Ovis aries*.

*Location:* Small intestine.

*Distribution:* Wyoming, U.S.A.

*Specimens:* U.S.N.M. Helma. Coll. no. 46922 (type) and 46921 (paratypes).

This species closely resembles *N. spathiger* in the termination of the spicules (Fig. 1, B). It differs, so far as the writers are aware, from that

species and from all others of the genus *Nematodirus* occurring in ruminants by the size of the bursa and the nonbifid tip of the dorsal ray. These species may be differentiated by the following key.

KEY TO MALES OF THE SPECIES OF NEMATODIRUS  
IN RUMINANTS

1. Terminal portions of dorsal rays undivided  
*N. rufaevastitatis*, n. sp.
- Terminal portions of dorsal rays divided..... 2
2. Terminal portion of spicules bent  
*N. tarandi* Hadwen
- Terminal portion of spicules straight..... 3
3. Small gubernaculum present  
*N. urichi* Cameron
- Gubernaculum absent..... 4
4. Mediolateral and posterolateral rays well separated..... *N. roscidus* Railliet
- Mediolateral and posterolateral rays close together..... 5
5. Spicules differing in length, terminal portion twisted..... *N. abnormalis* May
- Spicules equal in length, terminal portion straight..... 6
6. Cuticular expansion of terminal portion of spicules spatulate..... *N. spathiger* (Railliet)
- Cuticular expansion of terminal portion of spicules sharply pointed..... 7
7. Cuticular expansion of terminal portion of spicules 0.1 mm long..... *N. helveticus* May
- Cuticular expansion of terminal portion of spicules 0.06 to 0.08 mm in length..... 8
8. Terminal portion of each spicule divided into two rodlike structures united at the tips  
*N. oiratianus* Rajewskaja
- Terminal portion of each spicule not divided  
*N. filicollis* (Rudolphi)

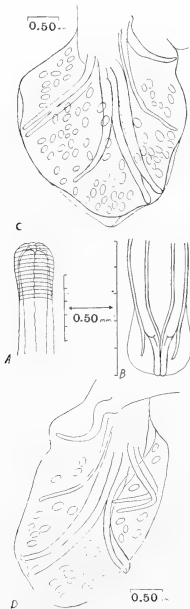

FIG. 1.—*Nematodirus rufaevastitatis*, n. sp.: A, Head; B, spicules; C, D, lateral lobes of bursa.

REFERENCES

- RAJEWSKAJA, S. A. Zur Charakteristik der Nematoden der Gattung *Nematodirus* Ransom 1907 (Versuch einer Monographischen Bearbeitung). Zeitschr. Infektionskr... Haustiere Berlin 40 (2-3): 112-136. 1931.
- RANSOM, B. H. The nematodes parasitic in the alimentary tract of cattle, sheep, and other ruminants. U. S. Dept. Agr. B.A.I. Bull. 127. 1911.
- PRICE, E. W. A new nematode, *Nematodirus antilocaprae*, from the prong-horn antelope, with a key to the species of *Nematodirus*. Proc. U. S. Nat. Mus. 71 (art. 22): 1-4, pl. 1, figs. 1-4. 1927.
- TRAVASSOS, L. Contribuições para o conhecimento da fauna helmintológica brasileira. XIII: Ensaio Monográfico do família Trichostrongylidae Leiper, 1909. Mem. Inst. Oswaldo Cruz 13 (1): 1-135. 1921.
- . Revisão do família Trichostrongylidae Leiper, 1912. Monogr. Inst. Oswaldo Cruz, 512 pp., pls. 1937.



## Officers of the Washington Academy of Sciences

*President*.....NATHAN R. SMITH, Plant Industry Station  
*President-elect*.....WALTER RAMBERG, National Bureau of Standards  
*Secretary*.....F. M. DEFANDORF, National Bureau of Standards  
*Treasurer*.....HOWARD S. RAPPLEYE, U. S. Coast and Geodetic Survey  
*Archivist*.....JOHN A. STEVENSON, Plant Industry Station  
*Custodian and Subscription Manager of Publications*  
 HARALD A. REHDER, U. S. National Museum

### *Vice-presidents Representing the Affiliated Societies:*

Philosophical Society of Washington.....EDWARD U. CONDON  
 Anthropological Society of Washington.....WALDO R. WEDEL  
 Biological Society of Washington.....  
 Chemical Society of Washington.....JOSEPH J. FAHEY  
 Entomological Society of Washington.....FREDERICK W. POOS  
 National Geographic Society.....ALEXANDER WETMORE  
 Geological Society of Washington.....LEASON H. ADAMS  
 Medical Society of the District of Columbia.....  
 Columbia Historical Society.....GILBERT GROSVENOR  
 Botanical Society of Washington.....E. H. WALKER  
 Washington Section, Society of American Foresters.....WILLIAM A. DAYTON  
 Washington Society of Engineers.....CLIFFORD A. BETTS  
 Washington Section, American Institute of Electrical Engineers

FRANCIS M. DEFANDORF  
 Washington Section, American Society of Mechanical Engineers.....RICHARD S. DILL  
 Helminthological Society of Washington.....L. A. SPINDLER  
 Washington Branch, Society of American Bacteriologists.....ANGUS M. GRIFFIN  
 Washington Post, Society of American Military Engineers.....HENRY W. HEMPLE  
 Washington Section, Institute of Radio Engineers.....HERBERT G. DORSEY  
 District of Columbia Section, American Society of Civil Engineers.....

### *Elected Members of the Board of Managers:*

To January 1952.....W. F. FOSHAG, C. L. GAZIN  
 To January 1953.....C. F. W. MUESEBECK\*, A. T. MCPHERSON  
 To January 1954.....SARA E. BRANHAM, MILTON HARRIS\*

*Board of Managers*.....All the above officers plus the Senior Editor  
*Board of Editors and Associate Editors*.....[See front cover]

*Executive Committee*.....N. R. SMITH (chairman), WALTER RAMBERG, H. S. RAPPLEYE,  
 J. A. STEVENSON, F. M. DEFANDORF

*Committee on Membership*.....L. A. SPINDLER (chairman), M. S. ANDERSON,  
 MERRILL BERNARD, R. E. BLACKWELDER, R. C. DUNCAN, G. T. FAUST, I. B. HANSEN,  
 D. B. JONES, DOROTHY NICKERSON, F. A. SMITH, HEINZ SPECHT, ALFRED WEISSLER

*Committee on Meetings*.....MARGARET PITTMAN (chairman), NORMAN BEKEDAHL,  
 W. R. CHAPLINE, D. J. DAVIS, F. B. SCHEETZ, H. W. WELLS

### *Committee on Monographs:*

To January 1952.....J. R. SWALLEN (chairman), PAUL H. OEHSER  
 To January 1953.....R. W. IMLAY, P. W. OMAN  
 To January 1954.....S. F. BLAKE, F. C. KRACEK

*Committee on Awards for Scientific Achievement* (GEORGE P. WALTON, general chairman):  
 For the Biological Sciences.....G. H. COONS (chairman), J. E. FABER, JR.,  
 MYRNA F. JONES, F. W. POOS, J. R. SWALLEN

For the Engineering Sciences.....R. S. DILL (chairman), ARSHAM AMIRKIAN,  
 J. W. MCBURNEY, FRANK NEUMANN, A. H. SCOTT

For the Physical Sciences.....G. P. WALTON (chairman), F. S. BRACKETT,  
 G. E. HOLM, C. J. HUMPHREYS, J. H. McMILLEN

For Teaching of Science.....B. D. VAN EVERA (chairman), R. P. BARNES,  
 F. E. FOX, T. KOPPANYI, M. H. MARTIN, A. T. MCPHERSON

*Committee on Grants-in-aid for Research*.....L. E. YOCUM (chairman),  
 M. X. SULLIVAN, H. L. WHITTEMORE

### *Committee on Policy and Planning:*

To January 1952.....J. I. HOFFMAN (chairman), M. A. MASON  
 To January 1953.....W. A. DAYTON, N. R. SMITH  
 To January 1954.....H. B. COLLINS, JR., W. W. RUBEY

### *Committee on Encouragement of Science Talent:*

To January 1952.....M. A. MASON (chairman), A. T. MCPHERSON  
 To January 1953.....A. H. CLARK, F. L. MOHLER  
 To January 1954.....J. M. CALDWELL, W. L. SCHMITT

*Representative on Council of A. A. A. S.*.....F. M. SETZLER

*Committee of Auditors*.....J. H. MARTIN (chairman), N. F. BRAATEN, W. J. YOUDEN

*Committee of Tellers*.....W. G. BROMBACHER (chairman), A. R. MERZ, LOUISE M. RUSSELL

\*Appointed by Board to fill vacancy.

## CONTENTS

	Page
PHYSICS.—The limitations of the principle of superposition: II. PAUL R. HEYL.....	149
ETHNOLOGY.—Some medical beliefs and practices of the contemporary Iroquois Longhouses of the Six Nations Reserve. MARCEL RIOUX..	152
GEOLOGY.—Present Cretaceous stratigraphic nomenclature of northern Alaska. GEORGE GRYC, W. W. PATTON, JR., AND T. G. PAYNE....	159
ZOOLOGY.—A new subgenus of <i>Diaptomus</i> (Copepoda: Calanoida), including an Asiatic species and a new species from Alaska. MILDRED STRATTON WILSON.....	168
HELMINTHOLOGY.—A new roundworm, <i>Nematodirus rufaevastitatis</i> (Nematoda: Trichostrongylidae), from domestic sheep, <i>Ovis aries</i> , in Wyoming. CHARLES G. DURBIN AND RALPH F. HONESS.....	179

506.73  
D2W23

VOL. 41

JUNE 1951

No. 6

JOURNAL  
OF THE  
WASHINGTON ACADEMY  
OF SCIENCES

BOARD OF EDITORS

CHARLES DRECHSLER  
PLANT INDUSTRY STATION  
BELTSVILLE, MD.

WILLIAM F. FOSHAG  
U. S. NATIONAL MUSEUM

J. P. E. MORRISON  
U. S. NATIONAL MUSEUM

ASSOCIATE EDITORS

J. C. EWERS  
ANTHROPOLOGY  
C. W. SABROSKY  
ENTOMOLOGY  
F. A. CHACE, JR.  
BIOLOGY

J. I. HOFFMAN  
CHEMISTRY  
T. P. THAYER  
GEOLOGY  
MIRIAM L. BOMHARD  
BOTANY

R. K. COOK  
PHYSICS AND MATHEMATICS

PUBLISHED MONTHLY  
BY THE  
WASHINGTON ACADEMY OF SCIENCES  
MOUNT ROYAL & GUILFORD AVES.  
BALTIMORE, MARYLAND

Entered as second class matter under the Act of August 24, 1912, at Baltimore, Md.  
Acceptance for mailing at a special rate of postage provided for in the Act of February 28, 1925.  
Authorized February 17, 1949

## Journal of the Washington Academy of Sciences

This JOURNAL, the official organ of the Washington Academy of Sciences, publishes: (1) Short original papers, written or communicated by members of the Academy; (2) proceedings and programs of meetings of the Academy and affiliated societies; (3) notes of events connected with the scientific life of Washington. The JOURNAL is issued monthly. Volumes correspond to calendar years.

*Manuscripts* may be sent to any member of the Board of Editors. It is urgently requested that contributors consult the latest numbers of the JOURNAL and conform their manuscripts to the usage found there as regards arrangement of title, subheads, synonymies, footnotes, tables, bibliography, legends for illustrations, and other matter. Manuscripts should be typewritten, double-spaced, on good paper. Footnotes should be numbered serially in pencil and submitted on a separate sheet. The editors do not assume responsibility for the ideas expressed by the author, nor can they undertake to correct other than obvious minor errors.

*Illustrations* in excess of the equivalent (in cost) of one full-page halftone are to be paid for by the author.

*Proof*.—In order to facilitate prompt publication one proof will generally be sent to authors in or near Washington. It is urged that manuscript be submitted in final form; the editors will exercise due care in seeing that copy is followed.

*Unusual cost* of foreign, mathematical, and tabular material, as well as alterations made in the proof by the author, may be charged to the author.

*Author's Reprints*.—Reprints will be furnished in accordance with the following schedule of prices (approximate):

Copies	4 pp.	8 pp.	12 pp.	16 pp.	20 pp.	Covers
100	\$3.25	\$6.50	\$ 9.75	\$13.00	\$16.25	\$3.00
200	6.50	13.00	19.50	26.00	32.50	6.00
300	9.75	19.50	29.25	39.00	48.75	9.00
400	13.00	26.00	39.00	52.00	65.00	12.00

*Subscriptions* or requests for the purchase of back numbers or volumes of the JOURNAL or the PROCEEDINGS should be sent to HARALD A. REHDER, Custodian and Subscription Manager of Publications, U. S. National Museum, Washington 25, D. C.

*Subscription Rates* for the JOURNAL.—Per year..... \$7.50

Price of back numbers and volumes:	Per Vol.	Per Number
Vol. 1 to vol. 10, incl.—not available.*	—	—
Vol. 11 to vol. 15, incl. (21 numbers per vol.)	\$10.00	\$0.70
Vol. 16 to vol. 22, incl. (21 numbers per vol.)	8.00	0.60
Vol. 23 to current vol. (12 numbers per vol.)	7.50	0.90

\* Limited number of complete sets of the JOURNAL (vol. 1 to vol. 40, incl.) available for sale to libraries at \$341.00

MONOGRAPH No. 1, "The Parasitic Cuckoos of Africa," by Herbert Friedmann. \$4.50

PROCEEDINGS, vols. 1-13 (1899-1911) complete..... \$25.00

Single volumes, unbound..... 2.00

Single numbers..... .25

*Missing Numbers* will be replaced without charge provided that claim is made to the Treasurer within 30 days after date of following issue.

*Remittances* should be made payable to "Washington Academy of Sciences" and addressed to the Treasurer, H. S. RAPPLEYE, 6712 Fourth Street, N.W., Washington 12, D.C.

*Exchanges*.—The Academy does not exchange its publications for those of other societies.

# JOURNAL

## OF THE

# WASHINGTON ACADEMY OF SCIENCES

VOLUME 41

June 1951

No. 6

ETHNOLOGY.—*Was the California condor known to the Blackfoot Indians?* CLAUDE E. SCHAEFFER, Museum of the Plains Indian, Browning, Mont. (Communicated by John C. Ewers.)

Elderly Blackfoot Indians, in recounting the faunal lore of a now vanished past, sometimes refer to an immense bird, which visited the eastern foothills and adjacent plains of the Montana-Alberta region. Nearly half a century has elapsed, at least, since it was last sighted in this region. As a result, few living Indians claim to have seen the great winged creature; most know it only through traditions handed down from previous generations. Agreement is general among modern Blackfoot, however, that it was an uncommon, if not rare, migrant to their territory. The species, despite the infrequency of its appearance, seems to have found a niche in native nomenclature, as well as mention in their ceremonial rites, folklore, and procurement practices. If we have evaluated correctly Blackfoot descriptions of its appearance and habits, the bird in question can scarcely be other than the California condor, *Gymnogyps californianus* (Shaw). Although apparently thus known to the Blackfoot of an earlier day, the condor, strangely enough, has eluded the sight (and gun) of all but one white observer in this area. Accordingly, the wanderings of this "greatest of all flying birds of the earth" so far north of its recognized range have largely gone unnoticed by modern ornithologists. It seems advisable, then, to record here existing information on the condor from Blackfoot oral chronicles, in the hope that a new paragraph may thereby be added to the wildlife annals of the northwestern Plains.

The possibility of the condor's movement northward into the northwestern margin of the Plains was first brought to the writer's at-

tention in connection with a study of Blackfoot ornithology. As part of this inquiry, identification of various local bird species was established with Indian informants and their respective native names recorded (Schaeffer, 1950). After the terms for the golden eagle (*pítâu*), bald eagle (*ksixkikini*), and turkey vulture (*pikoki*) were collected, coverage of the largest Raptores was deemed complete. However, informants volunteered the term *omoxsapítâu*, "big *pítâu*," and proceeded to describe the bird's appearance and habits. A new term was thus unexpectedly added to the check list of Blackfoot avifauna. Inquiries were accordingly instituted among a number of the oldest Indians of the Browning region, and their knowledge of the topic was explored. My sources of information are largely Piegan, and the data obtained refer primarily to Montana. A few traditions of Blood provenience are localized in the Calgary-Edmonton section of Alberta. Native testimony is presented here essentially as it was secured from the Indians. Distortions of fact arising from what appear to be errors of observation or lapses of traditional continuity are indicated as such in the text.

As a background against which to assay Blackfoot testimony on the condor, ornithological data on that species' range and incidence to the north are summarized below. The condor, reduced in numbers<sup>1</sup> and

<sup>1</sup> According to information based upon research by Dr. Carl B. Koford and communicated (11/28/50) to me by Dr. Alden H. Miller, Museum of Vertebrate Zoology, University of California, the number of surviving wild specimens of the condor is estimated at about 60. I am also indebted to Dr. Miller for his reading of the first draft of the present paper and for pointing out certain discrepancies in the data insofar as reference to the condor is concerned.

distribution in recent times, is now confined to "California west of the Great Basin and desert regions, and northwestern Lower California." Casually or formerly, the same authority (A.O.U. Check-list, p. 62) adds, it was reported from southeastern California, Oregon, and Washington. It may now be nearly if not actually gone from its former range in Baja California. In Oregon the presence of the condor on the lower Columbia River is attested by observers from the time of Lewis and Clark (1805-06) down to that of David Douglas (1825-27). There, it came in summer and fall to feed upon the spawned-out salmon, which lined the banks of the stream. For the State of Washington, the range is given as "north irregularly (west of Cascades) to northern boundary" (Dawson and Bowles, vol. 2, p. 548). A specimen was recorded at Fort Vancouver in 1827 (Bent, p. 12, citing Fleming). In 1826 Douglas stated that it was a common species as far north as the 49th parallel (Macoun and Macoun, p. 239). In southwest British Columbia, the Macouns (p. 239) characterize the condor as "a rare visitant at the mouth of the Fraser River . . . apparently attracted by the dead salmon." In 1880 J. Fannin reported seeing two birds at Burrard Inlet, while Rhoads, in 1893, stated that condors were reported on Lulu Island as late as "three or four years ago" (Bent, p. 12).

The consensus of ornithologists in respect to the condor's status on the Pacific coast north of California would seem to represent it as an extralimital wanderer in the region, particularly after the first quarter of the last century. Even on the lower Columbia, Harris (p. 21) remarks, "there is no valid evidence that it was ever an abundant species," and by the time of Townsend's visit (1834-35) "it was already beginning to frequent this northern extremity of its range in fewer numbers." Similarly, Gabrielson and Jewett (pp. 180-181) conclude that the condor, "if ever common in this state [Oregon], seems to have become rare or almost extinct between Douglas' first visit [1825-27] and the time of the Pacific Railway Surveys" (1855-59). Farther north, Dawson and Bowles (2, p. 548) agree that "on the whole it appears improbable that the California condor was

ever resident in Washington, certainly not within the memory of the white man, and that its northern appearances are to be regarded solely as the fishing excursions of a Southerner." Taverner (p. 115) regards the reported occurrences in southwestern British Columbia as having an uncertain basis.

Turning now to the eastern limits of the condor's range, Dawson and Bowles (vol. 2, p. 548) remark that it formerly extended to Arizona and Utah. Bent (p. 12), on the basis of cave remains, notes that the species occurred in Nevada and New Mexico. It is recorded also in cave deposits from the Chisos Mountains. Certain "dubious" records report the condor in 1877 from Fort Sanders, southeastern Wyoming, and from some point in the mountains of Colorado (Harris, p. 46). There are perhaps other references from this southeastern area which have escaped my attention.

Farther to the north and more pertinent to our study, J. Fannin (p. 89), on September 10, 1896, observed two fine specimens between Calgary, Alberta, and the Rocky Mountains. This represents the sole ornithological record of the condor's presence within the purview of the Blackfoot.<sup>2</sup> Fannin admits in his report that he was not aware "that this bird was found east of the Rocky Mountains, or so far north as the point above mentioned." Later writers, such as the Macouns (vol. 2, p. 239), are inclined to doubt this occurrence so far east, especially since no specimen was collected. Although accepting the same student's sight record in southwestern British Columbia, Bent (p. 12) omits reference to the Alberta

<sup>2</sup> In this connection an entry from the diary of David Douglas (Harris, pp. 19-20), written at Fort Vancouver in 1827, may be quoted: "Obtained the following information concerning this curious bird from Etienne Lucien, one of the hunters who has had ample opportunity of observing them. . . . During the summer they are seen in great numbers in the woody parts of the Columbia, from the ocean to the mountains of Lewis and Clark's River, from four hundred miles in the interior" (italics mine). The region referred to here presumably is the drainage basin of the upper Snake River in present day Idaho. Since the source of this information is "the waggish Canadian voyageur who imparted to Douglas fantastic and highly imaginative misinformation regarding the nidification of the condor," the reference is scarcely taken seriously by ornithologists.

observation. Harris (p. 54) comments that the latter "would have been less startling had it been reported from this region seventy-five years earlier." And thus the case stands from the ornithological viewpoint.

A brief ornithological description of the condor may be included here, as comparative data against which to check Blackfoot accounts of the *omaxsapitau*. "Length, 4 to 4½ feet; spread of wings, 9 to 11 feet. Wings, long folding beyond end of square tail; head and neck, bare; skin, smooth, yellow or yellowish-orange and red; plumage, sooty-blackish commencing over shoulders with a semi-ruff of linear feathers, those underneath of similar character but less closely defined; the feathers of upper parts with browner tips; wings and tail black; outer webs of greater wing-coverts and secondaries grayish; wing-coverts and outer secondaries edged with whitish; *under wing-coverts, pure white*; bill, dark brown changing gradually to dull reddish on cere; iris, deep red; feet, horn with a patch on knees" (Pearson, p. 54). Parenthetically, while literature assigns a maximum wing spread of 11 feet the largest definite records range from 9 feet 9 inches to 10 feet.

We may next turn to the data representative of Blackfoot oral sources. The *omaxsapitau* is believed by some Indian informants to have visited the Browning area as recently as the early 1900's. Two or three very large birds are said to have appeared on the plains in various parts of the reservation about the year 1908. George Bull Child, one of those who saw them at the time, described the birds as dark in color and about 4 feet high. Since they took flight when approached closer than several hundred yards, he was unable to distinguish other salient features. At the time, however, older Piegan identified the species by its native name and recalled that it had visited the region at an earlier period.

A different version of possibly this same occurrence was obtained from Louis Bear Child. He stated that about the period 1907-08 some Gros Ventre Indians of the Fort Belknap Reservation, wrote Piegan friends that a great bird had been sighted in their part of north-central Montana. The Gros Ventre, although aware that it

was a migrant from the south, were concerned over the significance of the bird's appearance in their country. The Blackfoot watched for it that year, but so far as Bear Child was aware, no one saw it. The following year an earthquake is said to have shaken the Fort Belknap region, an event which Bear Child, and perhaps the Gros Ventre, were inclined to associate with the visit of the "big eagle."

The incident best known to contemporary Piegan involving the *omaxsapitau* is that related of the deceased Raven (Hairy Face). Raven, or as he is more commonly known among bilingual Blackfoot, Big Crow, was born on the Blood Reserve in Canada but reared on the Montana reservation. Accounts of his experience vary somewhat in detail, but the following version is one told by Richard Sanderville (age 82). Big Crow and his wife were returning from Old Agency to their home on Little Badger Creek. In a coulee near the latter place, Big Crow noticed a large object some distance off, which he at first believed was a cow. Upon approaching closer, however, he saw that it was an immense, dark-colored bird, with a feathered ruff and a bald head. The strange creature took wing and flew off to the mountains. Sanderville remarked that Big Crow was not familiar with the species or with its native name. Further, upon hearing of his experience later, several of his friends are said to have evinced incredulity. The year in which this occurrence took place, so far as Sanderville could date it, was 1897. Thereafter, in accordance with the Blackfoot year count, the year became known as "that in which Big Crow saw the *omaxsapitau*."

Another episode of this character was recalled by Sanderville. Mary Jane, daughter of the Piegan Red Paint, married a white man named Pfemster or Phemister. One summer she and her husband moved into the Chief Mountain district of what is now Glacier National Park to hunt and fish. While in camp one day they saw four very large birds. Two of them appeared to be immature, just learning to fly, while the others, believed to be the parent birds, soared overhead. The observers considered that the adult pair had nested (sic) on Chief Mountain that summer. From mem-

ory Sanderville placed the date of this occurrence in 1879. Mary Jane died in 1942 at the presumed age of 89.

Rides at the Door (age 87), one of the few surviving Piegan with a record in inter-tribal warfare, is said to have seen a "big eagle" while raiding for horses somewhere to the south. Handicapped by deafness, this aged warrior was unable to supply further details of his experience.

An incident related by Chewing Black Bones (age 83) also involved an encounter by a group of Piegan raiders with a "big eagle." The narrator's father, Brocky (Tail Feathers Coming Over a Hill), a prominent Piegan warrior, was a member of the party. Led by Heavy Runner, the warriors set out to steal horses from the Crow Indians. They had traveled as far as "Bear Creek," an unidentified stream located west of the present Crow Reservation in southeastern Montana. Heavy Runner, who was in the lead, looked up to see a very large bird flying directly before them. Its wingspread and length of tail, the raiders noted, exceeded those of the eagle. The sight was so unusual that Heavy Runner immediately accepted it as a portent bearing upon the success of their venture. Accordingly he warned his companions, saying, "I have never seen a bird of this kind. Now that it has appeared before us, I am afraid. It seems to be trying to head us off. The outcome of our raid is now in doubt. We had better turn back." Most of the party agreed, and they and Heavy Runner returned home. Of the six who continued on, five were killed by the enemy. Since Heavy Runner was killed in the Baker Massacre of 1870, the date of this raid may be set in the 1860's. Chewing Black Bones believed that the bird's appearance upon this occasion and others was prophetic of misfortune. In support of his contention, he cited the death of the five raiders and the extinction of the previously mentioned Big Crow's family line.

Dog Takes a Gun (age 85) was born on the Blood Reserve in Alberta but spent most of his life among the Montana Piegan. He recalls his parents' account of an *omaxsapitau* sighted near Calgary shortly before the time of his birth. The date is to be placed in the early 1860's. Again the great

size of the bird was emphasized. While feeding, it was said to lean forward so far that its breast nearly touched the ground. A tailfeather, described as about 2 feet in length, was dropped by this particular bird in flight and picked up by native observers. My informant added that the wing of another "big eagle" killed in this region equaled, when fully extended, the distance from a man's shoulder across his chest to the fingertips of his opposite outstretched arm.<sup>3</sup>

The next incident involves an encounter with the *omaxsapitau* by an Indian eagle trapper, now deceased. It was the practice of the Blackfoot, as with other tribes of the Northern Plains, to secure the feathers used in their costumes and ceremonial equipment from the golden eagle taken in concealed traps. Briefly, the procedure involved digging a shallow pit upon some eminence, covering it with brush and grass, and placing a stuffed coyote skin on top as bait. As the eagle alighted to feed, the hunter concealed within the pit, seized both legs of the bird, drew it down towards him, and dispatched it. Some degree of hazard was involved in this activity, in that failure to hold the captive securely often resulted in infliction of painful wounds from its talons. The supernatural powers attributed to the eagle evoked a series of conciliatory rites on the part of the trapper preceding and following its seizure.

White Bear, a conjuror and eagle trapper,<sup>4</sup> was a Cree by birth but intermarried among and lived with the Blood tribe of Blackfoot most of his life. He was said to have been about 83 years old at the time of his death in 1905. About 1850 White Bear was taking eagles in the region south of Edmonton, when an *omaxsapitau* visited his trap.

<sup>3</sup> Dog Takes a Gun claims to have seen this wing in the possession of a curio dealer in Calgary some 10 years ago.

<sup>4</sup> White Bear is noteworthy because of another practice attributed to him by his grandson. To tie himself up in the Houdini trick preliminary to a conjuring performance, he employed the leather thong, which also served as his ceremonial pack line (See Speck, 1935, p. 203, for the *nimaban* or ceremonial game carrying string of the Naskapi). The multiple functions thus assigned to the pack line opens up an interesting topic of investigation. So far as I am aware, the ceremonial game carrying string has never been reported among the Plains Cree.



Looking through the brush screen, he saw an immense bird soaring high in the air. After circling several times, the bird descended to the ground near the pit. It was quite wary, and only after considerable hesitation did it approach the bait. By this time White Bear had observed its size and concluded that it would be too difficult to capture, except at the risk of injury to himself. Seizing the stick used to frighten off the bald eagle, he thrust it through the pit cover and frightened the intruder away. Later he described it as the largest bird he had ever seen. It was dark in color with brown-striped tailfeathers (sic). Its head and hooked beak were large and its legs coarsely scaled. This incident was narrated by the grandson of the trapper, Harry Under Mouse.

Traditional information from a more distant past was secured from Yellow Kidney (age 80), whose knowledge of the earlier life and customs of the Piegan is extensive. In this connection he described the appearance and habits of the *omaxsapitau* in some detail. He referred to the characteristics of immense size and dark color, the great wingspread, and the elongated tail. He drew attention to the white underparts of the wings (sic) and, in contrast to the bald and immature golden eagle, the dark spots in the tailfeathers (sic). He described the large, hooked beak as dark blue, shading to yellow at the base. The head plumage (sic) was characterized as brownish in color.

Yellow Kidney was aware that the "big eagle's" home range lay far to the south and that it appeared infrequently in summer as far north as Montana and Alberta. Long ago he had been told by elderly Piegans that the great birds were attracted to this northern country by the remains of bison slain by the Indians on the plains. Richard Sanderville, it should be noted, also recalled traditions of their being seen feeding upon bison carcasses. At other times the *omaxsapitau* were sighted high in the air above the Blackfoot camps in the foothills. They would soar in wide circles and suddenly dart off at great speed towards the mountains to the west. There, early in the evening, the great birds sought rest atop some precipitous cliff, "where they slept with their heads tucked beneath their wings."

Yellow Kidney believed that long ago the Blackfoot succeeded, upon rare occasions, in capturing the "big eagle." At that time the conciliatory practices and disposal rites ordinarily associated with the young golden eagle were transferred to the *omaxsapitau*. The former bird, with its predominantly white tailfeathers, was considered a prize catch by all native trappers and special ceremonial treatment was accorded its remains. The informant went on to say that occasionally the nest (sic) of the *omaxsapitau* was so situated that hunters were able to make their way to it. Then the fledglings were removed, reared in captivity, and killed at maturity for their feathers. Seven primaries were detached from one wing and put aside for ritual disposal. The remaining wing primaries, the outer tailfeathers, the claws, and the wing-bones—humeri or ulnae—were then utilized for decorative and other purposes. The best feathers were employed for headdresses, the claws drilled for necklaces, and the wing-bones worked into whistles.

The flight powers of the "big eagle" enabled it to mount far into the sky and thus approach more closely to the Sun, the great celestial being of Blackfoot worship. As a result, the bird was believed to acquire a degree of the Sun's sacred character. The golden eagle, the white bison, the mountain lion, and a number of other birds and animals, by virtue of this or other attributes, were considered endowed with the same solar power. Hence to justify taking the life of one of these sacred creatures, as well as to avert subsequent misfortune, the Blackfoot sacrificed, whole or in part, its flesh and skin to the Sun. Accordingly, the seven wing primaries of the *omaxsapitau* were affixed to the tanned hide of a bison calf. They were arranged so that the quills came together at a point, with the distal ends spaced equidistant about a semicircle.<sup>5</sup> The

<sup>5</sup> Offerings thus made to a supernatural being appear to represent an old practice in Northern Plains cultures. Some years ago Wissler (p. 106, fn. 1) observed on the Blackfoot reservation a group of such offerings near a stone shelter used in the vision quest. They consisted of "an old coat, a shirt tied to a stick, and a peculiar fan-shaped object of twigs distended by being bound to a hoop of the same material. On the projecting ends of the twigs were eagle feathers. . . . We were told that such fanlike objects were often used when making

robe thus adorned was placed on top of a sweatlodge built for the occasion. Four medicine bundle owners of advanced age were then invited to enter the lodge, and while sweating, they prayed to the Sun for good fortune in various activities of life. At the conclusion of the observance, a youth carried away the decorated robe and placed it on a hilltop as a gift to the Sun.<sup>6</sup>

Previously an episode was given that involved an unexpected and possibly unwelcome visit of the *omaxsapitau* to the eagle trap. According to Yellow Kidney, however, it was the practice of an earlier generation of Blackfoot to take the great bird occasionally by this method, despite its wariness and size. In this case the immediate purpose was procurement of spiritual rather than material benefits. The trapper, it was explained, vowed to the Sun that if permitted to capture a "big eagle," he would, in the native idiom, "place fine pemmican<sup>7</sup> in its mouth." It was now expected that the normally shy bird, perhaps directed by the Sun, would circle the trap in flight and descend to the bait. The suppliant would then grasp its legs, immediately thrust forward a wooden billet for its talons to embed themselves (sic), pull it into the pit, place his knee upon its back and dislocate its neck. No part of the dead bird would be taken for the trapper's use. Instead, he removed the skin and mounted it in a lifelike manner, placed a morsel of pemmican in its beak, and abandoned it upon a hill as an offering to the Sun. In return for his sacrifice, the trapper anticipated that the spirit of the dead bird would appear to him in a dream and offer its supernatural power. The visitant would then say, "My name is *omaxsapitau*. I am known over all the earth. I am glad that you have treated me so well and offered me to the Sun. I will help you in any way that you may desire." Again it should be pointed out that

these rites were ordinarily associated with the young golden eagle.

In a dream revelation of this kind it was not unusual for the spiritual benefactor to bestow its name upon the human suppliant. The term *omaxsapitau* thus appears to have entered the Blackfoot system of individual names some generations ago. According to Yellow Kidney, a Piegan named Bird Flying High (*piksipoánsin*) was blessed in this way by the "big eagle." He belonged to a group of the Fat-roasters band, which intermarried among the Blood Indians and went to live with them in Canada. The great bird, it is stated, appeared to him in a dream and said, "I will give you my name. You will be called *omaxsapitau*. You will become chief of your band and live to a very old age." Bird Flying High thereupon adopted the name of Big Eagle, and the dream vision was consummated by his later rise to the position of band chief. Yellow Kidney claims that when he was a small child he saw Big Eagle, who was already advanced in age at that time. Hence the latter's dream experience may be placed some time in the period before 1850.

Big Eagle, following his dream experience, wore suspended from his hair two tailfeathers of the *omaxsapitau*, to which a medal was attached as a support. The former were a symbolical representation of his spiritual power from the "big eagle"; the latter, his power from the Sun. Yellow Kidney, in his early childhood, saw the supernatural token and recalled that the feathers surpassed those of the eagle in length. At times, our informant stated, Big Eagle would demonstrate his spiritual gifts through the use of his feather token. He would direct his friends, "Look up at the Sun. Do you see anything around it?" They would look and fail to see anything unusual. Then Big Eagle would begin the power song given him by the Sun, "When I come up to the top of the hill, I shall see all about me." As he sang, he motioned with one of the feathers as if marking out a spot above the Sun. A sun dog (parhelion) would thereupon appear beside it. In this way, according to Yellow Kidney, who witnessed the feat in his youth, Big Eagle could produce as many as four sun dogs about the Sun at one time.

sun offerings." The Kutenai similarly attached a small gift to a wooden hoop made of a twig as an offering to one of their supernatural spirits.

<sup>6</sup> For an account of Blackfoot sweat lodge rites and the disposition of offerings, see Wissler, pp. 259-62.

<sup>7</sup> A choice item of Blackfoot diet made from the tenderloin and marrow fat of the bison, mixed with berries and, for ceremonial purposes such as the above, divided into small pieces.

Information regarding another Blackfoot, who more recently bore the name of Big Eagle, was given by Harry Under Mouse. The source of the latter's data was Small Eyes, a prominent native ritualist on the Gleichen Reserve, Alberta. This Big Eagle, it appears, was a member of the All-Short-People band of the Blackfoot proper. He married a Blood woman and lived for some years among the members of that tribe. Big Eagle fasted for power in the region northwest of Calgary. On the top of Devil's Head Mountain, he sacrificed a piece of his flesh to the Sun. On nearby Bald Butte he then offered up to the "big eagle," a Cree foe, whom he had killed at the spirit bird's request. In return he received supernatural power for use in warfare from both spiritual beings. As a symbol of his aerial protector, Big Eagle carried a tailfeather of an *omaxsapitau*. Before starting out upon a raid, he would stick the feather upright in the ground by the ceremonial altar. The direction in which it fell during the night indicated the way he must travel to obtain horses from the enemy.<sup>8</sup>

The skill of the second Big Eagle as a raider was said to have depended, in part, upon his use of a root with soporific power. After rubbing some of it upon the feather token, he would chew a small piece and spit upon both his hands. Then, taking the feather, he would motion with it in a peculiar way and thereby cause an enemy sentry to fall into a deep sleep. By this means he is said to have stolen 200 horses from the Assiniboine and driven them safely home. Through his power to put the occupants of an enemy lodge asleep, Big Eagle is also credited with acquiring from adjacent tribes one or more pipe bundles, which were later passed down among the Blackfoot. On one occasion, it was narrated, he was surrounded by hostile Cree on the top of Devil's Head Mountain. Through use of his supernatural power Big Eagle rendered himself and his party invisible and safely passed through the enemy lines. When the Cree advanced to the summit, the only living thing seen

there was a great, dark-colored bird, which flew away. Big Eagle is said to have died in 1925, advanced in years. His son, Steven Fox (Short Crow or Thunder Chief), who now resides on the Blood Reserve, is said to have borne the name of Big Eagle during his younger years. The feather token of the elder Big Eagle came into possession of Small Eyes, but its present whereabouts are now unknown.

Harry Under Mouse informs me that other tangible remains of the *omaxsapitau* survived as late as a decade ago among the Cree Indians of Hobbema, south of Edmonton. He had been told by a Cree from that place that the ceremonial regalia of a performer in the Grass Dance consisted of the stuffed body, wings, and tail of one of these birds. The regalia was designed to be tied to the dancer's back, so that the condor's head rose above that of the wearer, the body and spread tail hung downward nearly to the ground, and an extended wing was attached to each arm. During the dance the wearer imitated the flight and other actions of the "big eagle." The bird that supplied this skin was presumably killed in this area by the Cree at some period in the past.

Native testimony in respect to the "big eagle" may be concluded by reference to its place in Blackfoot folklore. It will scarcely come as a surprise to learn that the *omaxsapitau* has become identified with the mythical roc in a Blood version of that tale.<sup>9</sup> The protagonist of the legend, according to Harry Under Mouse, is the aforementioned White Bear, "who first learned what and where the *omaxsapitau* was." As a result of his encounter with the bird, White Bear is said to have borne for a time the name of

<sup>8</sup> On the basis of preliminary results of a study now in progress, the Blackfoot *iniskim* or buffalo stone was employed in an analogous manner to determine, at certain times, the direction in which to hunt buffalo and, at others, to predict the outcome of the hunt.

<sup>9</sup> The Roc legend is perhaps widespread in North America. I have made no effort to trace its distribution in the Plains or adjacent areas in connection with this study. It may be noted in passing that a generalized version of the Blackfoot tale was obtained in 1947 from the Upper Kutenai, of Elmo, Montana, who assign its origin to the Sarsi. Fisher (p. 253) refers to the myth of an eagle or mythical bird abductor among such Algonkian-speaking groups, as the Micmac, Passamaquoddy, Malecite, Montagnais-Naskapi, Cree, Ojibwa, Menomini, Gros Ventre, and Cheyenne. Future folklorists, who trace the distribution of the myth, may well consider the condor as a possible influence in its western diffusion.

Big Eagle. The tale, it may be pointed out, conforms, in general, to the Blackfoot pattern of an individual's experience in the power quest.

The Blood tribe was encamped in the vicinity of modern Edmonton. Food was scarce and parties of hunters scattered out in different directions to search for game. Upon their return at night, one member of a party would be missing. Men continued to disappear in this way for some time.

Finally a party of four went out a long way to hunt. Near the place called Devil's Head, they put up a brush shelter for several days' stay. That night they sang their supernatural power songs for good luck in the next day's hunt. The following morning the four men started out, each in a different direction. All agreed to meet at camp that night.

A light snow fell that day. One of the hunters killed a deer. He butchered it and tied the meat in a pack upon his back. Then he started back for camp, using his bow as a cane to support the load. Walking along with his head bowed, he suddenly saw the shadow of a great bird upon the snow. He felt the bird grasp at the meat on his back, and the next instant realized that he was rising in the air. Too frightened now to look down, he closed his eyes. After a brief period he felt solid ground beneath his feet and lay back with the pack still in place. He opened his eyes to see that he was in a large nest surrounded by the bones of deer, bison calves and even human beings. It came to him then that the last represented the remains of those hunters recently lost.

He sat up and looked around. The nest was located upon a high cliff, from which escape seemed impossible. Nearby was an immense bird, which cried in a strange way. The hunter realized this was the creature that had carried people away. He called upon the Sun for aid. Beside him were two young birds, scarcely able to fly. He began to pray to them for help. Untying his pack, the hunter threw bits of meat to them, which they ate. He continued doing this in order to bring them closer.

Finally, he pushed the whole chunk of meat over. The feeding birds were now within reach. He quickly grasped their legs in each of his hands. They began to flap their wings, nearly jerking him into the air. Still retaining his hold, he inched over to the edge of the cliff. Then he pushed the birds off into space, throwing himself

off at the same instant. Again he closed his eyes. He found that the flight power of the birds, although insufficient to support his weight, served to check his descent to the ground. It seemed a long way down. Finally he landed in safety. Before releasing his rescuers, he detached the longest feather from the tail of each bird. Then he started to make his way home.

It was late in the evening when he arrived at camp. He recognized the cries of his wife and parents, who were mourning atop a nearby hill. As he listened, someone went over and led them back to their lodge. He looked inside the lodge and saw that his people had cut off their hair and gashed their arms and legs. Only then did he realize that they were mourning his death. Going inside, he greatly surprised the occupants. They could scarcely believe that he was alive, but he convinced them that he was not a ghost.

The hunter then asked his wife to invite the old men of the camp to his lodge. His mother began to prepare food for them. After all had eaten, he related his experience and as proof displayed the tail feathers of the young birds. As the old men examined the trophies, they noted that they were nearly the length of a grown person's arm. The hunter's companions, who had also returned by this time, told how they had followed his tracks to where they ended in the snow and picked up his bow nearby. In this way it became known what creatures had caused the people to disappear. As a result of this incident, the hunter later received supernatural power from the "big eagle."

Accounts from Blackfoot oral sources previously set forth in respect to the *omaxsapitau* and its place in the ethno-ornithology of that group may now be summarized. The identification of the *omaxsapitau* as the condor and the latter's occurrence in Blackfoot territory rests upon three types of traditional evidence: (1) a series of native sight records made over a period of half a century or more, (2) reflections of identity and presence in various aspects of Blackfoot culture, and (3) notions of modern Indians regarding the bird's size, habits, and appearance derived from (1) and (2). The second of these types of data has been adequately treated in the body of this study. Hence, it will suffice to summarize in some detail the remaining two.

As a rough measure of the validity of our

data, we may comment briefly here upon the degree of interest manifested by the Blackfoot in the avian world. In general, it may be said, wildfowl represented a segment of the local fauna and flora, which, together with the Blackfoot and their cultural structure, constituted a closely knit biotic community of the northwestern Plains. The place of the Blackfoot in such an ecological system may be epitomized by Speck's characterization (1921, p. 349) of the Algonkians of the northeastern forests, a comment that applies equally well to their linguistic congeners of the plains: "The native Indians live much closer to Nature than most white people could hope to do. Their knowledge of wildlife is therefore inexhaustible in quantity, though it is often far from being scientifically correct." The Blackfoot, dependent predominantly upon the bison for subsistence, were better mammalogists, perhaps, than ornithologists. Nevertheless, the group built up over generations an extensive body of knowledge based upon observation of the local avifauna, the influence of which pervaded such varied fields as hunting and trapping, material crafts and decorative arts, curing practices, folklore, and ceremonial rites, songs, and dances. As a result, most Blackfoot became acquainted from childhood with the appearance, habits and culturally defined attributes of the avian species within their ken. It is against this background of familiarity that native testimony on the *omaxsapitau* should be evaluated.

In respect to the physical features and habits of the *omaxsapitau*, nearly all Blackfoot traditions stressed the factors of great size and dark color. Other elements cited by one or more informants, include the naked head, the feather ruff, the dark, hooked beak, the length and power of the wings, the white area underwing, the extended tailfeathers, and the coarsely scaled legs. Reference was also made to the bird's wariness, its habit of soaring in great circles and suddenly darting off at great speed, and the inclined posture in feeding. Certain of these traits, such as the feathered ruff, bald head, great size, etc., are sufficiently distinctive of the condor to suggest identity.

In contrast to the preceding list of characteristic traits must be set others atypical

of the condor. Such discrepancies in our data have been noted wherever recognized. Some, no doubt, represent errors introduced unconsciously into the flow of Blackfoot traditions. Others appear to be traits transferred by native observers from the golden eagle to the *omaxsapitau*. Nidification in the eastern foothills of the Rockies, undoubtedly, represents one such case. The predatorial habit assigned in the Blood legend to a scavenger species is another. It may be recalled that the Indians classified the *omaxsapitau*, both taxonomically and terminologically, with the golden eagle. Only one informant, Jim White Calf, seemed aware of the former's genetic relationship to the turkey vulture. The confusion evident in the minds of native ornithologists may have been the result of the condor's infrequent appearances in this area, in modern if not in earlier times. Few Blackfoot during the last century have ever seen the species at close hand or over a period of time. In view of this unfamiliarity, it is surprising that greater errors have not been introduced in native descriptions. Such, then, represents the traditional evidence upon which identifications of the condor must, at the moment, rest.

Turning next to the reported occurrences of the *omaxsapitau* in Blackfoot territory, we find that they are placed by native observers, both living and dead, at irregular intervals from the early 1900's back to the middle of the previous century. Of such appearances, the least credible, perhaps, is that of 1907-08, a date posterior to the final sight record (Rhoads) of the condor on the north Pacific coast<sup>10</sup> by more than a decade. Raven's reported observation of the *omaxsapitau* in 1897 comes within a year of Fannin's sight record near Calgary. Preceding these appearances is the Phemister occurrence of the 1870's; those of Takes a Gun's parents and Brocky's of the 1860's; and White Bear's of the 1850's. The testimony of Yellow Kidney in respect to the Indian named Big Eagle and to other topics, seems referable to a still earlier period. From these data, scanty and unsatisfactory

<sup>10</sup> Gabrielson and Jewett (p. 181) report, on the basis of what appears to them good authority, the presence of two or more condors in southern Oregon in 1903 and again in 1904.

as they are, it would seem that the condor appeared in the Montana-Alberta region prior to the 1850's sufficiently often to leave a definite impress upon Blackfoot institutions and thus give rise to the traditions related by Yellow Kidney. Such seasonal movement of the condor northward along the Continental Divide may, perhaps, parallel its observed wanderings (1805-34) up the west coast to the lower Columbia and the Fraser. In subsequent decades the species was seen less frequently in Montana and Alberta, as well as along the coast, until its terminal appearance in both regions just before the close of the century.

A final point already mentioned in our study calls for elaboration here. The historical sources indicate that the condor was attracted to the lower Columbia and lower Fraser Rivers by the multitude of dead, migrant salmon, which in autumn lined the banks of those streams. What comparable food resource, it may be asked, served to draw the species to the northwestern margin of the Plains? The black-tailed deer<sup>11</sup> immediately comes to mind, the range of which has been shown to closely overlap that of the condor (Elliott, p. 122). However, it seems more probable, as native traditions suggest, that the bird's major item of subsistence in this region lay in the readily accessible remains of bison killed by the Blackfoot and their neighbors. As Ewers (p. 358) has recently pointed out, the impounding of bison at drive sites was largely carried on by the Blackfoot late in fall and early in winter, a period which found the condor absent from the north. However, a plentiful supply of meat in this area was assured during the warmer months of the year. Then the hunt was also organized on a cooperative, group basis in the form of the surround on horseback, or at an earlier period, on foot. The abandonment by hunters of bison bones and offals at this season, which in fall supplied tallow and meat for the man-

<sup>11</sup> One authority believes that the condor preferred deer meat to any other. He observes that "they can make hash of a dead deer, sheep or other small animals; yet it seems that they have not the power to cut through the skin of a horse, cow or other large animal until the meat is somewhat decomposed" (Elliott, pp. 123-24, quoting Pemberton).

ufacture of pemmican, afforded a source of diet for the condor and other carnivorous creatures.

In conclusion, information gathered from Blackfoot traditionalists suggests, in the writer's opinion, the condor's former movement northward, as a casual and infrequent visitant, along the eastern slopes of the Rockies as far as Montana and Alberta. The evidence for this statement is scarcely of a nature as to win acceptance from modern ornithologists, whose standards of proof require something more tangible than sight records or native traditions. The present study, however, is designed to stimulate further investigation of the topic. Inquiries should be carried out among Canadian Blackfoot and adjacent Cree, from whom significant information, and, even more concrete evidence of the species' identity and presence may still be obtained. If such data are forthcoming, it will be possible to add, in the words of one student, "another section to the jigsaw puzzle of *Gymnogyps*' extra-limital wanderings." Until that time, memories of the "big eagle" will continue to be preserved among the descendants of those bison-hunting tribesmen, who long ago observed its great, sweeping flights from out of the fastnesses of the Rockies.

#### BIBLIOGRAPHY

- AMERICAN ORNITHOLOGISTS' UNION. *Check-list of North American birds*, ed. 4. 1931.
- BENT, ARTHUR C. *Life histories of North American birds of prey, part 1*. U. S. Nat. Mus. Bull. 167. 1937.
- DAWSON, WM. L., and BOWLES, JOHN H. *The birds of Washington*, 2 vols. Seattle, 1909.
- ELLIOTT, CHARLES (ed.). *Fading trails: The story of endangered American wildlife*. New York, 1943.
- EWERS, JOHN C. *The last bison drives of the Blackfoot Indians*. Journ. Washington Acad. Sci. 39: 355-360. 1949.
- FANNIN, J. *The California vulture in Alberta*. Auk 14: 89. 1897.
- FISHER, MARGARET W. *The mythology of the northern and northeastern Algonkians in reference to Algonkian mythology as a whole*. In "Man in Northeastern North America," Frederick Johnson (ed.). Pap. Robert S. Peabody Foundation for Arch. 3: 226-262. 1946.
- GABRIELSON, IRA N., and JEWETT, STANLEY G. *Birds of Oregon*. Corvallis, 1940.
- HARRIS, HARRY. *The annals of Gymnogyps to 1900*. Condor 43: 3-55. 1941.

- MACOUN, JOHN and JAMES H. *Catalogue of Canadian birds*. Geological Survey of Canada, Ottawa, 1909.
- PEARSON, GILBERT T. (ed.). *Birds of America*. Garden City, 1936.
- SCHAEFFER, CLAUDE E. *Bird nomenclature and principles of avian taxonomy of the Blackfoot Indians*. Journ. Washington Acad. Sci. 40: 37-46. 1950.
- SPECK, FRANK G. *Bird-lore of the Northern Indians*.

- Public Lectures by Univ. of Pennsylvania Faculty, 1919-20, 7: 349-380. 1921.
- . *Naskapi: The savage hunters of the Labrador Peninsula*. Norman, Okla., 1935.
- TAVERNER, P. A. *Birds of Canada*. Dept. of Mines, Nat. Mus. Canada, Bull. 72, biol. ser. 19. Ottawa, 1934.
- WISSLER, CLARK. *Ceremonial bundles of the Blackfoot Indians*. Amer. Mus. Nat. Hist. Anthropol. Pap. 7 (2). 1912.

**PALEONTOLOGY.**—*New Desmoinesian crinoids*. HARRELL L. STRIMPLE, Bartlesville, Okla. (Communicated by Alfred R. Loeblich, Jr.)

*Glaukosocrinus*, n. gen., is here proposed with *G. parvisculus* (Moore and Plummer), n. comb. as the genotype species. Description of *Aesiocrinus erectus*, n. sp., *Acrocrinus expansus*, n. sp., *Lecythiocrinus optimus*, n. sp., and *Schistocrinus ovalis*, n. sp., is given. All figured specimens are from exposures of the Oologah limestone formation, sometimes referred to the Altamont limestone of Kansas, Des Moines series, Pennsylvanian, located east of Tulsa, Okla.

***Glaukosocrinus*, n. gen.**

Dorsal cup moderately low truncate, semi-globular with deep basal invagination. Columnar scar small, round, occupying the median portion of a relatively large IBB circlelet. Five small IBB are restricted to basal concavity. Five moderately large BB form a part of the lateral calyx walls and flex strongly inward to form sides of the basal concavity. Five large RR have short articulating processes which are directed mildly outward. Outer surfaces of RR curve in to form adsutural slopes between articulating facets. Anal X is large, pentagonal and does not extend into the interbrachial region. RA is pentagonal and rests on r. post. and post. BB. It supports a small pentagonal RX, which extends only slightly into the interbrachial area.

*Genotype.*—*Malaiocrinus parvisculus* Moore and Plummer (1940).

*Known range.*—Des Moines series, Pennsylvanian; North America.

*Discussion.*—This form was referred to *Malaiocrinus* Wanner (1924) by Moore and Plummer (1940). It has certain characteristics superficially similar to that genus and may represent a trend of specialization leading to the genus but certain factors seem sufficient to warrant separation. *Malaiocrinus* has anal plates of normal structure

in normal (primitive) arrangement. Anal X is hexagonal. In *Glaukosocrinus* the anal plate is pentagonal and does not extend above the normal cup height. The radial articulating facets of *Malaiocrinus* are long, directed strongly outward and the columnar scar is very large, almost entirely covering the IBB plates. *Glaukosocrinus* has short radial articulating facets directed only slightly outward and the columnar scar is small.

***Glaukosocrinus parvisculus* (Moore and Plummer), n. comb.**

Figs. 13-16

This species has been adequately described. The specimen figured herein was collected by the author in the stone quarry some 7 miles east of Tulsa, Okla.

**Genus *Aesiocrinus* Miller and Gurley, 1890**  
***Aesiocrinus erectus*, n. sp.**

Figs. 9-12

Dorsal cup is broad, truncate bowl-shaped. Five IBB form a large pentagonal-shaped disk with slightly depressed median section. Five large BB curve into the subhorizontal basal area but also comprise a good portion of the lateral cup walls. Five large RR have arm articulating facets directed slightly outward and not entirely filling the distal faces of the plates. Outer ligament furrow is shallow but well defined. Ligament pit furrow is shallow and ligament pit is sharply impressed. Transverse ridges are sharply defined, narrow lateral furrows are backed by unusually long oblique ridges. Muscle scars are limited in area and are deeply impressed. Intermuscular notches and furrows are broad and short. The right shoulder of l. post. B is extended and has an extra facet for reception of an anal tube plate. R. post. R and the anal plate are

missing in the holotype but measurements leave no doubt as to the existence of only one anal plate in the posterior interradius, which plate was in broad contact with the post. B.

The entire surface of the dorsal cup is mildly granular in appearance. Depressions occur at the apices of RR and BB. Columnar scar is decidedly pentagonal in outline. Maximum width of dorsal cup is 18.5 mm, height 8.2 mm.

*Remarks.*—The general contour of the dorsal cup of *A. erectus* is very similar to that of several species of *Plummericrinus* Moore and Laudon (1943) and is quite unlike that of any other species of *Aesicrinus*. Characteristics, other than general appearance, in common with *Plummericrinus* are the depressions at the angles of BB and RR and the extension of the outer surfaces of RR into the adsutural area between the arm articulating processes. However, *Plummericrinus* has three anal plates in the posterior interradius and a round stem.

*Occurrence.*—Stone quarry some 7 miles east of Tulsa, Okla.

*Holotype.*—Collected by the author. To be deposited in the U. S. National Museum.

Genus *Acrocrinus* Yandell, 1846

*Acrocrinus expansus*, n. sp.

Figs. 1, 17–20

Dorsal cup is of moderate height, wide at the base and mildly constricted at the distal extremity. Two BB of equal size are confined to a shallow basal concavity. The walls of the basal depression are composed of two circlets of small

plates. Five RR are hexagonal and are adjoining except where interrupted by the large anal X in the posterior interradius. Articular facets are small, horse shoe shaped.

The BB and RR are separated by about six circlets of plates which are designated as intercalaries (ii). In the first circlet below the RR and anal X series, there are 12 hexagonal ii<sup>1</sup>, 14 ii<sup>2</sup>, 16 ii<sup>3</sup>, and 14 ii<sup>4</sup>. Exact placement of succeeding series is difficult owing to slight irregularities and the incipient nature of those nearest the BB. Plates of the posterior interray continue unbroken to the BB disk and also in the anterior ray. In other rays the series are broken. Considering the large number of plates the arrangement is remarkably symmetrical.

The columnar scar is very small and round. Arms and tegmen have not been observed. Cup plates are devoid of ornamentation. Greatest width of dorsal cup (basal) is 11.0 mm, width at distal extremity is 6.5 mm, height 9.0 mm.

*Remarks.*—*Acrocrinus wortheni* Wachsmuth (1882), *Acrocrinus pumpkensis* Strimple (1949), *A. brentwoodensis* Moore and Plummer (1937), and *A. pirum* Moore and Plummer (1937) have calices similar to the present species in general outline. They have broad basal areas and tend toward constriction in the distal extremities of the cup. *A. pirum* is elongated and has a greater number of plates than other species. *A. wortheni* has fewer plates and a different arrangement of intercalaries than found in *A. expansus*. *A. pumpkensis* has a limited number of intercalaries and the cup does not constrict so noticeably at the

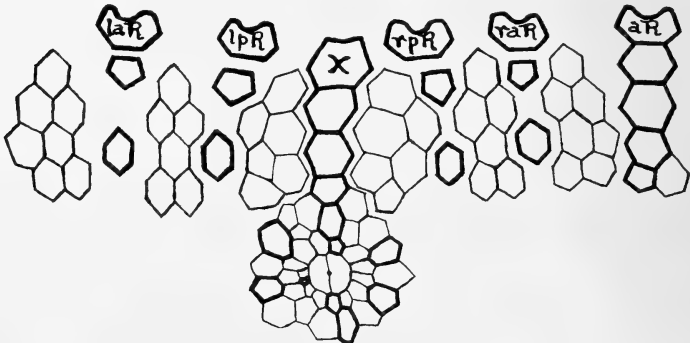
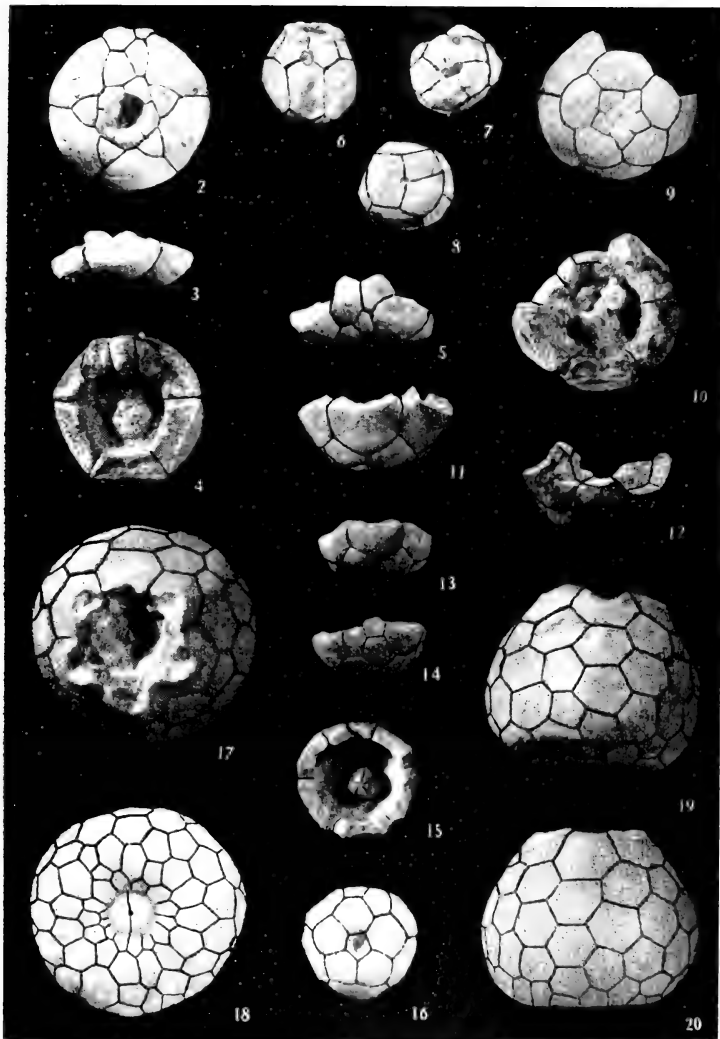

FIG. 1.—Diagrammatic sketch showing arrangement of plates in the holotype of *Acrocrinus expansus*, n. sp.





FIGS. 2-5.—Holotype of *Schistoerinus oralis*, n. sp., from below, anterior, summit, and posterior,  $\times 1.8$ . FIGS. 6-8.—Holotype of *Lecythioerinus optimus*, n. sp., from posterior, summit, and base,  $\times 1.8$ . FIGS. 9-12.—Holotype of *Aestioerinus erectus*, n. sp., from base, summit, anterior, and posterior,  $\times 1.6$ . FIGS. 13-16. Typical representative of *Glaukoserinus parviscolus* (Moore and Plummer), n. comb., from anterior, posterior, summit, and base,  $\times 1.8$ . FIGS. 17-20. Holotype of *Aeroerinus expansus*, n. sp., from summit, base, anterior, and posterior,  $\times 3.5$ .

distal extremity. In *A. brentwoodensis* all RR are in contact with four plates in addition to lateral contact with adjoining RR, whereas in *A. expansus* only the two posterior RR have contact with four plates and the three anterior RR are each in contact with three plates.

The only other described Pennsylvanian species is *A. elegans* Strimple (1949) which has a slender, elongated cup.

*Occurrence*.—Stone quarry about 7 miles east of Tulsa, Okla.

*Holotype*.—Collected by Melba Strimple. To be deposited in the U. S. National Museum.

Genus *Lecythiocrinus* White, 1880

*Lecythiocrinus optimus*, n. sp.

Figs. 6-8

Dorsal cup is elongated, more or less spherical in outline. Three unequal IBB form a mildly up-flared, broad base. The smaller IB is right posterior. Five BB are long, hexagonal plates with proximal portions curved to join IBB plates. Five RR are small pentagonal plates with prominent, wide arm articulating facets. There is a pronounced reduction in width of RR as the upper edge of the cup is approached. An oval shaped opening is in the upper extremity of post. B and lower lateral portions of l. post. and r. post. RR. When the cup is viewed from above or below there is a mildly pentagonal outline due to slightly raised median areas in the proximal portions of BB.

Columnar scar is small, round. Arms and tegmen are unknown. The greatest width of dorsal cup is 10.4 mm, height 10.6 mm.

*Remarks*.—*L. optimus* differs from other described species in having broad, rather distended articulating processes. The outline of the cup is somewhat comparable to those of *L. adamsi* Worthen (1883) and *L. olliculaeformis* White (1880).

*Occurrence*.—Road cut on eastward extension of thirty-first Street, southeast of Tulsa, Okla.

*Holotype*.—Collected by Frank Crane. To be deposited in the U. S. National Museum.

Genus *Schistocrinus* Moore and Plummer, 1940

*Schistocrinus ovalis*, n. sp.

Figs. 2-5

Dorsal cup is shallow, bowl-shaped. In the median portion of a broad, shallow basal con-

cavity there is a sharply impressed, small, round columnar scar. Five IBB form a cog shaped disk surrounding the impressed area. Five small BB are more or less triangular shaped plates with the exception of post. B which is rather elongate and is truncated for reception of anal X. Five large RR are in solid contact with the IBB plates and prevent lateral contact between BB. Three anal plates are in normal (primitive) arrangement. RA is a narrow, elongate plate supporting the narrow proximal face of RX above and is in contact with anal X to the left. RX expands noticeably as it enters the interbrachial region. Anal X is a large, long plate.

All cup plates are unornamented. Arms and tegmen are unknown. The dorsal cup has a width of 16.6 mm, height of 3.5 mm.

*Remarks*.—*S. ovalis* is more comparable with *S. torquatus* Moore and Plummer (1940), the genotype species, than with other described forms. *S. torquatus* has more prominent IBB plates, the impressed basal area is entirely occupied by the columnar scar, BB have more angular proximal facets and the plates of the posterior interradius are more advanced in arrangement.

*Occurrence*.—Stone quarry about 7 miles east of Tulsa, Okla.

*Holotype*.—Collected by the author. To be deposited in the U. S. National Museum.

REFERENCES

- MILLER, S. A., and GURLEY, W. F. E. *Journ Cincinnati Soc Nat. Hist.* **13**: 14. 1890.  
 MOORE, R. C., and LAUDON, L. R. *Geol. Soc. Amer. Spec. Pap.* 46: 56, 58. 1943.  
 ——— and PLUMMER, F. B. *Bull. Denison Univ., Journ. Sci. Labs.*, **32**: 218-244, pl. 12, figs. 1-3. 1937.  
 ———. *Univ. Texas Publ.* 3945: 98-101, pl. 14, fig. 6; pp. 217-222, pl. 2, fig. 6. 1940.  
 STRIMPLE, H. L. *Amer. Journ. Sci.* **247**: 900-904, pl. 1, figs. 1-6, 1949.  
 WACHSMUTH, C. *Illinois State Mus. Nat. Hist. Bull.* 1: 41. 1882.  
 WANNER, J. *Perm. Krin. Timor, 2<sup>e</sup> Nederl. Exped.*: 177-183. 1924.  
 WHITE, C. A. *Proc. U. S. Nat. Mus.* **2**: 256, pl. 1, figs. 4-5. 1880.  
 WORTHEN, A. H. *Illinois State Mus. Bull.* 1: 37. 1883.  
 YANDELL, L. P. *Amer. Journ. Sci.*, ser. 2, **20**: 135-137. 1846.

PALEONTOLOGY.—*Brachiopod homonyms*. G. ARTHUR COOPER, U. S. National Museum, and HELEN M. MUIR-WOOD, British Museum (Natural History).

While preparing a list of the brachiopod genera for the forthcoming "Treatise on Paleontology," the authors found a number of homonyms, which are adjusted below. In addition to these, three names previously thought to be homonyms proved to have been incorrectly replaced. Substitutions for these erroneously displaced names are also included herein.

*Argentiproductus* nom. nov. for *Thomasella* Paul, 1942, Zentralbl. Min. Geol. Paläont., Abt. B, **6**: 191 (non Fredericks, 1928, Bull. Com. Géol. Leningrad **46** (7): 778, 789, Brachiopoda).

Type species: *Producta margaritacea* Phillips, 1836.

*Callispirina* nom. nov. for *Mansuyella* Reed, 1944, Palaeont. Indica (n. s.) **23**, mem. 2: 505 (non Endo, 1937, Bull. Manchurian Sci. Mus. 1: 353, Trilobita).

Type species: *Spiriferina ornata* Waagen, 1887.

*Capillirostra* nom. nov. for *Rhynchonellopsis* Böse, 1894, Palaeontogr. **41**: 57, 77, 78, footnote (non Vincent, 1893, Ann. Soc. Malac. Belge **28**, mém.: 51, Brachiopoda).

Type species: *Rhynchonellina? finkelsteini* Bose, 1894.

*Elinoria* nom. nov. for *Elina* Fredericks, 1924, Bull. Com. Géol. Petrograd **38** (3): 320, 321 (non Blanchard, 1852, in Gray, Hist. Chile **7**: 28, Lepidoptera; or Ferrari, 1878, Ann. Mus. Stor. Nat. Genova **12**: 84, Hemiptera; or Houlbert, 1918, in Oberthuer, Étude Léop. **15**: 325, Lepidoptera).

Type species: *Spirifer rectangulus* Kutorga, 1844.

*EQUIROSTRA* nom. nov. for *Isorhynchus* King, 1850, Mon. Permian Foss., Palaeont. Soc.: 81, 112 (non Schoenherr, 1833, Gen. et Sp. Curc. **1** (1): 22; 1836, **3** (2): 631, Coleoptera).

Type species: *Terebratulites aequirostris* Schlotheim, as represented by DeVerneuil in Geologie de la Russie d'Europe **2**, pl. 3, fig. 1. 1845.

*Hirsutella* nom. nov. for *Hirsutina* Kirchner, 1934, Neues Jahrb. Geol. Paläont. **71**, Abt. B (1): 106 (non Tutt, 1909, Brit. Butterfl. **3**: 154, Lepidoptera).

Type species: *Spirifer hirsutus* Alberti, 1864.

*Labriproductus* nom. nov. for *Worthenella* Girty, 1938, Journ. Washington Acad. Sci. **28** (10): 442 (non Walcott, 1911, Smithsonian Misc. Coll. **57** (5): 125, Vermes).

Type species: *Productus wortheni* Hall, 1858.

*Marionites* nom. nov. for *Marionella* Bancroft, 1928, Mem. Manchester Lit. Phil. Soc. **72**: 181 (non Cobb, 1922, Journ. Washington Acad. Sci. **11**: 504, Vermes).

Type species: *Marionella tyra* Bancroft, 1928.

*Nudirostra* nom. nov. for *Leiorhynchus* Hall, 1860, Ann. Rep. New York State Cab. Nat. Hist. **13**: 75 (non *Liorhynchus* Rudolphi, 1801, Archiv Zool. [Wiedemann] **2** (1): 49, Vermes).

Type species: *Orthis quadricostata* Vanuxem, 1842.

*Phymatothyris* nom. nov. for *Pallasiella* Renz, 1932, Abh. Schweiz. Paläont. Ges. **52**: 40, 41 (non Sars, 1895, Crustacea Norway **1**: 505, Crustacea; or Kirby, 1910, Synon. Cat. Orthopt. **3**: 168, Orthoptera).

Type species: *Pallasiella kerkyraea* Renz, 1932

*Pirgulia* nom. nov. for *Pirgula* DeGregorio, 1930, Ann. Géol. Paléont. Palermo **52**: 30 (non Tessmann, 1921, Mitt. Zool. Mus. Berlin **10**: 215, Lepidoptera).

Type species (by monotypy): *Lyttonia? (Pirgula) pedicula* (DeGregorio, 1930).

*Plectorhynchella* nom. nov. for *Monticola* Nalivkin, 1930, Mem. Com. Géol. Leningrad **180**: 86, 188 (non Boie, 1822, Isis [Oken] 1822: 552, Aves).

Type species: *Athyris collinensis* Frech, 1902.

*Sphaerirhynchia* nom. nov. for *Wilsonella* Niki-forova, 1937, Palaeont. U. S. S. R. Mon., Leningrad, **35**: 33 (non Carter, 1885, Ann. Mag. Nat. Hist. (5) **15**: 320, Spongiae).

Type species: *Terebratula wilsoni* J. Sowerby, 1816.

*Striüspirifer* nom. nov. for *Schuchertia* Fredericks, 1926, Bull. Acad. Sci. U. R. S. S. **20** (5-6): 406 (non Gregory, 1899, Geol. Mag. (n. s.) dec. 4, **6**: 351, Echinodermata).

Type species: *Delthyris niagarensis* Conrad, 1842.

*Sulcirostra* nom. nov. for *Rhynchonellopsis* DeGregorio, 1930, Ann. Géol. Paléont. Palermo **55**: 6 (non Vincent, 1893, Ann. Soc. Malac. Belge **28**, mém.: 51, Brachiopoda).

Type species: *Rhynchonellina sequenzae* Gemmellaro, 1871.

*Tunarites* nom. nov. for *Tunaria* Hoek, 1912, Neues Jahrb. Min. Geol. Stuttgart, Beil. Bd. **34**: 247 (non Link, 1807, Besch. Nat. Samml. Univ. Rostock **3**: 165, Coelenterata).

Type species. *Tunaria cochambina* Hoek, 1912.

#### SUBSTITUTIONS FOR EXISTING NAMES

*Aethia* Thomson, 1915, Geol. Mag. **2**: 389 (non *Aethia* Merrem, 1788, Vers. Grundr. Gesch. Vögel I, Tent. Nat. Syst. Av.: 7, 13, 20, Aves; and Hübner, 1825, Verz. bekannt. Schmett.: 340, Lepidoptera.). Substitute *Thomsonica* Cossmann, 1920, Rev. Crit. Paléozool. **24**: 137.

Type species: *Terebratula qualteri* Morris, 1850.

*Megerlia* King, 1850, Mon. Permian Foss., Palaeont. Soc.: 81, 145, not preoccupied by *Megerlea* Robineau-Desvoidy, 1830, Mem. Prés Acad. Roy. Sci. Inst. France **2**: 266, Diptera. *Mühlfeldtia* Bayle, 1880, Journ. Conch. **28**: 240, proposed for *Megerlia* King, 1850, is a synonym.

Type species: *Anomia truncata* Gmelin, 1767.

*Yakovlevia* Fredericks, 1925, Rec. Geol. Com. Russian Far East **40**: 7 (non *Jakowleffia* Puton, 1875, Petites Nouvelles Ent. **1** (128): 512, Hemiptera). Substitute *Muirwoodia* Licharew, 1947, C. R. Acad. Sci. Moscow (n. s.) **57** (2): 187.

Type species: *Productus mammatus* Keyserling, 1846.

PALEONTOLOGY—*Substitution for the preoccupied brachiopod name Hystricina.*

MERRILL A. STAINBROOK, Brandon, Iowa. (Communicated by G. A. Cooper.)

Dr. G. Arthur Cooper has recently informed me that Dr. Helen Muir-Wood and he have discovered that the name *Hystricina*, proposed by me in 1945 for a genus of atry-  
poid brachiopods, is preoccupied by *Hystri-*

*cina* Malloch, 1932 (Rec. Canterbury [N. Z.] Mus. **3**: 433). To replace it I am suggesting *Spinatrypa* (*Hystricina* Stainbrook, not *Hystricina* Malloch, 1932). The type species is *Atrypa hystrix* var. *occidentalis* Hall.

BOTANY.—*A contribution to the lichen flora of Alaska.* GEORGE A. LLANO, Arctic, Desert, Tropic Information Center, Maxwell Air Force Base, Alabama. (Communicated by John A. Stevenson.)

The following new species, varieties, forms, new names, and distributions have been taken from a manuscript prepared as a report<sup>1</sup> of field work carried out in Alaska by the author in the summer of 1949 and by P. F. Scholander in 1948. The final report will contain a record of all macrolichens collected in Alaska including the Aleutians. All *Stereocaula* and Cladoniaceae were determined, respectively, by Dr. I. M. Lamb and Dr. A. W. Evans.

- Stereocaulon glareosum* (Sav.) H. Magn. in Göteborgs Kgl. Vet. och Vitterh.-Saml. Handl. **30**: 60. 1926.  
var. *brachyphyloides* M. Lamb, var. nov.

A specie typica differt phyllocladiis subper-sistententer graniformibus aut subdigitato-con-crescentibus, passim tantum papillae-formiter

excrecentibus; cephalodia magna, conspicua, ut in forma typica.

Forming caespitose-pulvinate, low clumps with uneven surfaces. Podetia firmly attached to the soil, short and stout, up to 1.5 cm long and 1-2 mm thick, congested, irregularly branched, ± upright or variously intricated, not dorsiventral; ± terete, clothed down to the base with a thin, smooth, adpressed, pale rosy-subochraceous tomentum; rigid but not markedly ligneous. Phyllocladia lateral on podetia, scanty in lower parts, congested and numerous in upper parts, cinereous-whitish, matt, unicolorous, mostly con-crescent grainlike or con-crescent-subdigitate,

<sup>1</sup> *Studies on the lichen flora of Alaska.* The North Slope of the Brooks Range, with Appendix. The work on which this report is based was supported by the Arctic Institute of North America with funds provided by the Office of Naval Research and was conducted under the auspices of the Smithsonian Institution.

small (0.1–0.2 mm } diam.), only rarely and in a few places becoming ± distinctly elongate-papillate. Cephalodia abundant, conspicuous, laterally sessile on podetia, smoothly subglobose, well constricted at base, 0.4–1.5 (–3.0) mm diam., pale roseate-brownish (± flesh colored), matt, the surface smoothly continuous or often rhagadiose-fissured; the larger ones (3 cm diam.) becoming irregularly pulvinate and dividing into several irregular convex portions. Reactions: phyllocladia KHO + greenish-yellow, Pd + (slowly) sulphur-yellow.

ALASKA: 151–152°W., 68°20'N., Anaktuvuk Pass, 1,000 m.s.m. on naked soil, coll. G. A. Llano & Neil Weber 527 (no. 1161, Lamb, TYPE), sterile.

2. *St. paschale* (L.) Hoffm. Deutsch. Fl. 130. 1796.

var. *erectum* (Frey) M. Lamb, comb. nov.

Podetia developing in a compact or loose manner, erect to suberect, about 4 cm high, somewhat branched.

Anaktuvuk Pass, Llano 402b, in a dry aggraded stream floor, among mosses and *Peltigera*.

3. *Peltigera venosa* (L.) Baumg. Fl. Lipsiens. 581. 1790.

f. *tartarea* Llano, forma nov.

Superficies superior sordida, pruina pulverulenta vel squamosa tecta, inferior tomentosa, alba usque pallide bruneola, venis carentibus vel inconspicuis; sporae aciculares, 2–3 septatae, hyalinae, 36–40 × 4–6.6 $\mu$ . A typo differt disereptione superficialium durarum.<sup>2</sup>

Upper surface dull, covered with a powdery to scaly white pruina; lower surface tomentose, white to pale brownish without veins, or veins indistinct.

Lake Schraeder, 145°W., 69°20'N., on soil, P. F. Scholander, 1948.

4. *Parmelia birulae* Elenk. in Ann. Mycol. Berlin 4(1): 36. 1906.

var. *grumosa* Llano, var. nov.

Thallus imbricatissimus, acervis valde arcuatis compositus, lobis latis e lobulis minoribus fimbriatus; cortex superior ceraceo-furfuraceus.

Thallus strongly imbricated in strongly arched heaps, lobes broad with sharp to rounded sinuses and fringed with smaller lobelets, upper cortex waxy-furfuraceous.

Anaktuvuk Pass, at the summits of lower mountains in protected depressions over mosses or other lichens. Llano 236, 485d.

5. *Cetraria scholanderii* Llano, sp. nov.

Thallus foliaceus, 10–15 cm in diam., lobato-crenatus, 4–6 mm latus, rugulosus, lobis valde imbricatis, ascendentibus, inflexis vel canaliculatis praeditus; cortex superior isidiis dense congregatis, simplicibus vel bifurcatis, albis obscuris, verruciformibus vel vermiformibus ad apices obscuras tectus, pallide griseolus vel pallide griseo-vinaceus, interdum atro-strigosus vel marginibus olivaceis vel viridi-nigris, nitens; cortex inferior atro-piceus, deinde atro-brunneus vel interdum pallide brunneus in apicibus loborum, subnitidus, leniter venato-bullatus rugosusque, areis rhizinarum tenuium fibrosarum vel verrucis conspersis praeditus; cortex superior K+, intense viride-flavus, medulla K–, K(C)–, J–.

Apothecia varia, lateralia vel subterminalia, subpedicellata, 5–6 mm. lata; discus planus usque subconvexus, carneo-pallidus, glaber usque subrugulosus, margine albe, isidiis numerosis brevibus atro-apiculatis ornatus vel albo-crenulatus; asci saccato-ovati, 42.9 × 22 $\mu$ , ad apices incrassati, octospori; paraphyses plus minusve distincti, septati, simplices, 1.43 × 38 $\mu$ ; sporae globoso-ellipsoideae, incolores, 9.9–11 (–13) × 3.3–5.7 (–6.6)  $\mu$ ; spermogonia non visa.

Thallus foliaceus, 10–15 cm in diam., lobate-crenate, 4–6 mm wide, rugulose, with strongly imbricated, ascending, inflexed or canaliculate lobes, upper cortex obscured by densely growing simple or bifurcate, white to dark, verruciform to vermiform isidia with darka pices, color light grayish, or light grayish-vinaceous with occasional streaks of black, with olive-green margins, or dull greenish black, shiny; lower cortex pitch-black becoming dark brown to pale shiny brown on occasional lobe tips, subshiny, weakly veined-bullate and wrinkled, with scattered patches of thin, stringy rhizinae, or warts; upper cortex K+ bright green-yellow, medulla K–, K(C)–, J (subsection *Glauscetes*).

Apothecia rare, terminal or marginal, subpedicellate, 5–6 mm wide, disk plane to subconvex, flesh-colored, smooth to slightly ridged, thalline margin white, with numerous short black-tipped isidia or white crenulate; asci 42.9 × 22 $\mu$ , with thick hyaline apices, paraphyses more or less distinct, septate, simple, 1.43 × 38 $\mu$ , spores 8 in ascus, globose to ellipsoid,

<sup>2</sup> Edith K. Cash, Plant Industry Station, Beltsville, Md., kindly provided all Latin descriptions except for *Sterocaulon*.

with distinct wall, 9.9–11 (–13)  $\times$  3.3–5.7 (6.6)  $\mu$ .

This species differs from *C. chrysantha* by its grayish coloring and densely isidiate upper surface; it differs from *C. norvegica* in color as well as in the type of isidia. *C. norvegica* is described with isidia cylindrical to coralloidea-ramose developing from furrows or lobe margins; these are relatively fine, brown-tipped isidia. The isidia of *C. scholanderii* are coarse, robust, tipped with black, simple to bluntly bifurcate, densely growing over the thallus, not from furrows and less so on the margins of lobes. Named after Dr. Peter F. Scholander, who first brought it to my attention, in appreciation of his many collections from the Brooks Range. A ubiquitous species along the Brooks Range, around Anaktuvuk Pass growing on rocks, over mosses and other lichens, along talus slopes up to 3,000 feet (154, 323, 330, 341, 390, 406).

Type, Lake Schrader, July 20, 1948, P. F. Scholander and W. Flag.

#### 6. *Alectoria irvingii* Llano, sp. nov.

Thallus subcaespitosus, depressus, subrigidus; rami 8 (–10) cm longi, dichotome divisi, axilibus late-angularibus, ad apices attenuati, subfibrillosi, fibrillis ad axes rectos vel recurvos rectangulariter dispositis, ad bases robusti, 1–2 mm lati, torti, cortice interdum rimoso et aperto, in hemicyclis volventes, intertexti, sulcati, interdum foveolati, demum cylindricales vel angulares, subcompressi vel ad locum ramorum plani, deinde cylindricales, nitidi, olivaceo-brunnei vel in partibus umbratis pallidiores, vel atro-brunnei, ramis vetustioribus et basibus subnigrescentibus; apothecia, spermogonia, soredia, et pseudocyphellae carentes.

Thallus subcaespitose, depressed, subrigid, branches 8(10) cm long, dichotomously branched, with wide-angling axils, apically attenuate, subfibrillose, with fibrils at right angles to main straight or recurved axis, at base robust, 1–2 mm wide, twisted with cortex occasionally split and gaping, winding in half-circle loops, interangled, furrowed, with occasional depressions, becoming cylindrical or angular, subcompressed or plane at point of branching, and then cylindrical, shining, olive-brown (or pale brown in shaded portions), dark brown, older branches and base somewhat blackened; apothecia and spermogonia absent, subsection *Sulcatae*.

Anaktuvuk Pass, over exposed gravel and thin soil with *P. birulae*, *C. scholanderii*, *S. globosus*, *P. omphalodes*, growing in mats 15–20 cm wide,

on upper slopes (4,000 feet) of quartzite mountain. This species looks somewhat like *A. nitidula* but more robust. Named after Dr. Lawrence Irving, first director of Arctic Research Laboratories, Point Barrow, Alaska, through whose encouragement Alaskan lichen studies were made possible.

#### 7. *Usnea scholanderii* Llano, sp. nov.

Thallus erectus aut subpendulous, ca. 4–6 cm altus aut flocci-formis (1–3 cm) et flaccidus, stramineo- vel pallide viridis, ad basim leniter pallide fuscescens, subconstrictus, dense et irregulariter, dein subsympodialiter ramosus; rami primarii usque ad 0.5–1 (–2) mm crassi, teretes, creberrimi, sat attenuatim subfibrillosi, cortice non rimoso, plerumque ad basim papillati, papillis minutissimis, ad ramos tenuiores rarioribus, ad apices subpapillati vel glabri, valde sorediati; soredia primum parva, farinosa, maniciformiter unita, dein soralia magna (1–2 mm. lata) numerosa, globosa alba vel albo-flava fibrillulis multis radiantibus praedita efformantia; apothecia et spermogonia non visa; medulla K–, cortex K–, soralia K + ferrugineo-brunnea.

Thallus erect to somewhat pendulous, 4–6 cm long, somewhat flaccid, tuft-like (1–3 cm high), straw- to yellowish-green, base somewhat stained rusty-brown, somewhat constricted, densely irregularly branched, cylindrical, becoming subsympodial, apically attenuate, subfibrillose, cortex usually papillate at base, subpapillate to smooth apically, not cracked, strongly sorediate, at first small, farinose, uniting to maniciform type, then forming numerous, large (1–2 mm wide), globose soralia, white- to white-yellow, with many radiating fibrils; apothecia and spermogonia not seen; medulla K–, cortex K–, soralia K + rusty-brown.

On rocks, with *P. sulcata*, common, Lake Peters (ca. Lake Schrader) leg. P. F. Scholander, July 1948. Not to be confused with *U. sorediifera*, *U. glabrata*, *U. vainioi*, or others listed by Motyka under stirps *U. sorediiferae*. Usneaceae are apparently scarce on the North Slope.

In accordance with the Rules of International Nomenclature, the following new names are proposed:

#### 1. *Cetraria magnussonii* Llano, nom. nov.

*Cetraria arctica* H. Magn., in Svensk Tidskr. 30: 251. 1936, is a later homonym of *Cetraria arctica* (Hook.) Tuck. Magnusson's species is

described from material collected in the Yenisei region of Siberia and is quite distinct from the Tuckerman species which is now referred to the genus *Dactylina* Nyl.

2. *Evernia perfragilis* Llano, nom. nov.

*Alectoria arctica* Elenk. & Sav. Acta Horti Petrop. 32: 73. pl. 1, fig. 1-3. 1912.

*Evernia arctica* (Elenk. & Sav.) Lyngbe in Lich. Nov. Zemlya 209. 1928.

The type material and subsequent collections from Novaya Zemlya, as well as Alaska, are all sterile. The author concurs with Lyngbe and Du Rietz<sup>3</sup> in believing that this species is, morphologically, more closely allied to the genus *Evernia*. However, the specific epithet is a later homonym of *Evernia arctica* (Hook.) Tuck., i.e., *Dactylina arctica* (Hook.) Tuck.

The distribution of lichen species in Fenno Scandia, in the Arctic islands north of Europe, and on the east and west coasts of southern Greenland are better known than those of Siberia, Alaska, and the Canadian Arctic Archipelago. Even so, the work of Scandinavians on occasional collections from the Canadian Archipelago and similarly of the Russians from rare Siberian collections has given some hints of the probable distribution of lichen species throughout the circumpolar area. Northern Alaska has long represented a vacuum in our understanding of even the commoner species, and has contributed little to add to continuous distributional studies of lichens. For this reason, collections from Arctic Alaska invariably contain new distributions, mainly northern extensions of species. The following anomalous distributions are of unusual interest since they would indicate a geographical pattern of Siberian species extending into North America.

*Parmelia birulae* Elenk., described from material collected in Novaya Zemlya, is a common element of the north slope of the Brooks Range. Material described to the author by N. Hale from his Baffinland collections of 1950 would indicate that this species extends throughout this range, and possibly to northern Greenland. An equally ubiquitous species is *Cetraria chrysantha* Tuck. with a similar extension. *Cetraria sibirica* H. Magn., first described from the Yenisei Region, Siberia, was collected at

Umiat, although it was not seen in the Brooks Range proper. A close relative, *C. magnussonii*, also from the Yenisei, should be looked for in Arctic Alaska. *Evernia perfragilis*, reported only from Novaya Zemlya, is represented in Alaska from two collections at Anaktuvuk Pass. *Ramalina almqvistii* Vain., first described from St. Lawrence Island, later reported by Degelius from Hulten's Aleutian collections, is a common species on the North Slope. This suggests that it may be noted inland or on the Siberian coast.

A further example of this type of distribution and also of disrupted range is *Umbilicaria caroliniana* Tuck. Originally described from Grandfather Mountain, N. C., it is now known to exist on Mount Mitchell and Roan Mountain, N. C. Later, it was reported from Japan, and then from the Amur District, Siberia. In a recent publication by the author,<sup>4</sup> it is reported a common element of the lichen flora on conglomerate, sandstone, and quartzite throughout the north slope of the Brooks Range. Its eastern North American terminus is recognized as a classical relict plant area; its eastern Asiatic terminus represents a weakly, if at all, glaciated area. The Alaskan finds are from a similarly poor or nonglaciated region from Kiana (collections of L. J. Palmer) and the Seward Peninsula east along the north slope of the mountain ranges to Lake Schrader. The intervening absence of the species from northern Alaska to North Carolina would appear to have been the direct result of the last extensive glaciation. The absence of records from localities in North Carolina north along the Appalachians to about the southernmost extension of the ice sheet, about latitude 40°N., does not remove the possibility that it may yet be found to have a more general distribution in eastern United States. It may possibly be reported from areas between Alaska and North Carolina but the examination of hundreds of specimens of Umbilicariaceae from these areas would appear to exclude this assumption.

<sup>4</sup> A monograph of the family Umbilicariaceae in the Western Hemisphere, 281 pp., 30 maps, 18 pl., and additional figures. Office of Naval Research, Department of the Navy, October 1950. Copies may be requested from the Department of Botany, Smithsonian Institution, Washington 25, D. C.

<sup>3</sup> DU RIETZ, G. E., Ark. Bot. 20(11). 1926.

Dr. Evans will report more fully upon the Cladoniaceae. However, three new records include *Cl. metacorallijera* Asahina, *Cl. gonecha* (Ach.) Asahina, and *Cl. pseudomacilentia* Asahina.

Among the Physciaceae collected, the following species were all noted from the North Slope: *P. aipolia* (Ehrh.) Hampe, *P. tenella* (Scop.) Bitt., *P. ciliata* (Hoffm.) DR., and *P. teretiusscula* (Ach.) Lynge.

Scholarer in 1948 collected two species of *Lobaria* at Bethel on the Kuskokwim River, *L. scrobiculata* (Scop.) Gartner and

*L. hallii* (Tuck.) Zahlbr. These are new but expected distributions on the northwest coast of Alaska. However, he also collected the first species at Lake Peters and the second species at Lake Chandler about 30 miles from Anaktuvuk Pass. The distribution of *L. hallii* is most interesting, for since it was first described by Tuckerman from material sent him by the Rev. Hall from Oregon, it has also been recorded in rare instances from southernmost Greenland and northern Scandinavia.

**BOTANY.**—*New or critical Euphorbiaceae from eastern Asia.* HSÜAN KENG, Department of Botany, National Taiwan University, Taiwan, China. (Communicated by Egbert H. Walker.)

This paper consists of descriptions of some new species and varieties and a new genus from eastern Asia, as well as critical notes and new records, reductions, and combinations. The types of the forms herein described are all preserved in the herbarium of the National Taiwan University, Taiwan, China. Specimens designated "FRI" belong to the Taiwan Forestry Research Institute.

**Phyllanthus** Linn.

1. **Phyllanthus indicus** (Delz.) Muell. Arg. in *Linnaea* **32**: 52. 1863; Merr., *Enum. Philippine Fl. Pl.* **2**: 392. 1923; Kanehira, *Formos. Trees*, rev. ed., 355. f. 311. 1936.

*Glochidion longipedicellatum* Yamamoto in *Journ. Soc. Trop. Agr.* **5**: 178. 1933; S. Suzuki in *Masamune, Short Fl. Formosa* **121**. 1936. (New synonym.)

TAIWAN: Lutung, Taipei, *Yoshimude 27128* (FRI); Shinrin-chun, Kaoshiung, *S. Sasaki 27137* (type of *G. longipedicellatum*), November 1927.

**Glochidion** Forster

1. **Glochidion fortunei** Hance var. *longistylum*, var. nov.

A typo speciei stylo longiore, 4–5 mm longo, differt.

Leaves elliptic-ovate, the apex caudate-acute, apiculate, the base cuneate or acute, 3–5 cm long, 2–3 cm wide. Capsules 8–10 mm in diameter, 5–6-celled; persistent calyx about 5 mm in diameter; calyx-lobes oblong, acute; style-column 3–4.5 mm long, thickened and

5–6-lobed at the apex; pedicels 5–6 mm long.

TAIWAN: Chisan, Kaoshiung, *Yamamoto & Mori 760*, August 14, 1936.

A variety characterized by the much longer styles.

2. **Glochidion fortunei** Hance var. *megacarpum*, var. nov.

A typo speciei capsula majore, 12–14 mm diametro, differt.

Leaves rounded-ovate, 2–5.5 cm long, 1.5–2.5 cm wide, the apex rounded or obtuse, mucronate, the base cuneate, acute. Capsules 12–14 mm in diameter, 5–6 mm long; persistent calyx 4–5 mm in diameter; pedicels 3–5 mm long, rather stout.

TAIWAN: Kaoshiung-wan, Kaoshiung, *Kudo & Suzuki 96*. April 8, 1929.

A variety characterized by the much larger capsules, about 5–6 mm in length and 12–14 mm in diameter.

**Agyneia** Linn.

1. **Agyneia taiwaniana**, sp. nov.

*Agyneia bacciformis* A. Juss. misapplied by Hayata, *Icon. Pl. Formosa* **9**: 95. 1920; Suzuki in *Masamune, Short Fl. Formosa* **118**. 1936.

Herba prostrata, glabra; rami et ramuli compresso-angulati. Folia parva, alternata, elliptica vel oblongo-elliptica vel lanceolata, 1–2 cm longa, 0.4–1 cm lata, apice obtusa vel acuta et mucronata, basi obtusa vel acuta; costae secundariae subdistinctae; petioli vix 1 mm longi. Flores ♂ 1.5 mm diametro, sepalis



oblongo-ovatis 0.8–1 mm longis apice albo-membraneis cincti, glanduloso-striolati; stamina 3, filamentis omnino in columnam connatis; pedicelli 1.5 mm longi. Flores ♀ 4.5–4.5 mm lati, sepalis oblongo-lanceolatis, 2 mm longis, acuminatis; ovarium cylindrico-obconicum, 1–1.2 mm longum, 1 mm latum, apice latum, obscure depressum; styli 3, liberi, divergentes, bifidi. Capsula subglobosa vel ovoidea, 4–4.5 mm longa, 3–4 mm lata.

Taiwan, abundant on the west coast of the south-central part of the island, near Chiayi, Tainan, and Hengchun.

TAIWAN: Peimen-chüan, Tidi-liu, Tainan, *K. Mori 110* (type), December 26, 1940; Anpin, Tainan, *Soma 14420* (FRI); Peimen, Chi-gou, Tainan, *K. Mori 530*; Chiayi, Tainan, *H. Keng 1375*; Hengchun, *H. Keng 322*.

A species formerly identified by Hayata as *A. bacciformis*, which is a species widely distributed over southern China (?), Java, Ceylon, India, and Maritius. No authentic Indian specimens have been examined, but when compared with the descriptions of *A. bacciformis* by Hooker (Fl. Brit. Ind. 5: 285. 1890) and Pax and Hoffman (in Engler, Pflanzenr. 81: 213. 1922) and with the illustrations by Wight (Icon. Orient. pl. 1992. 1852) and Pax and Hoffman (l.c. 213. f.18), this new species appears to differ chiefly in the cylindrico-obconical ovary and the smaller fruits. The ovary of *A. bacciformis* is broadly ovoid and the fruit is about 6 mm long and 5 mm wide. The sizes of the floral parts of both sexes also do not agree in these two species.

2. *Agyneia goniocladus* (Merr. & Chun), comb. nov.

*Phyllanthus goniocladus* Merr. & Chun in Sunyatsenia 2: 260. f. 51, 1935; Tanaka & Odashima in Journ. Soc. Trop. Agr. 372. 1938; Masamune, Fl. Kainan. 169. 1943.

HAINAN: Tung-koo-shan, *H. Fung 20418* (paratype of *P. goniocladus*); *Masamune & Fukuyama 4*, November, 1940.

In this species the male sepals are thick, with white margins, and the styles are small on the excavate top of the ovary. These are critical characters of *Agyneia*, rather than of *Phyllanthus*.

This species can also be separated from the Formosan *A. taiwaniana* in the subcylindrical ovary and the much shorter filament columns. The *Agyneia* of southern China, as cited by Pax

and Hoffman from Kwangtung and Hongkong (l. c. 214), is very probably referable to this species.

*Liodendron*, gen. nov.

Arbores vel frutices. Folia alterna, crenulato-serrulata vel integerrima, membranacea vel coriacea, tenuiter pennivenia et reticulato-venosa. Flores axillares, dioici, apetalii, disco nullo, ♂ racemosi vel spicati, brevissime pedicellati; ♀ longius pedicellati, solitarii. Fl. ♂: calyx tenuis, 4–6-partita, segmentis inequalibus, imbricatis; stamina 2, filamentis compressis; antherae globoso-ellipsoideae, erectae, extrosae, loculis distinctis, parallelis, longitudinaliter dehiscentibus; ovarii rudimentum 0. Fl. ♀: calyx tenuis, 5-partita, segmentis augustis; ovarium oblongo-ovoideum, 3-loculare; ovula in loculis gemina; styli longiusculi, in ramis ubique carnosos papillosos expansi. Drupa oblongo-ovoidea, endocarpio duro, fere osseo, abortu 1-locularia, 1-sperma. Semina oblongo-ovoidea; testa crustacea, albumen carnosum; embryo rectus, cotyledonibus latis, planis.

Type species: *Liodendron matsumurae* (Koidzumi), comb. nov., infra.

This new genus is very near *Putranjiva*, from which it differs in the male flowers being in axillary racemes and in the definitely 2 stamens, while in *Putranjiva*, the male flowers are solitary or in axillary clusters, never in racemes or in spikes, and the number of stamens is 2–4.

The arrangement of flowers in spikes or racemes, especially in the staminate plants, is an important character in the classification of the Euphorbiaceae. Bentham, for instance, in his treatment of the Australian Euphorbiaceae, divides this family into 5 tribes, tribe 3 (Antidesmeae) differing from tribe 4 (Phyllanthae) merely in the "flowers small, in catkin-like spikes or in racemes" in one, and the "flowers in axillary clusters or solitary" in the other (cf. Bentham, Fl. Austral. 6: 42. 1875).

Again, Pax and Hoffmann, in their monograph of the Euphorbiaceae, divide the tribe Phyllanthae into 22 subtribes, the first subtribe (Antidesminae) being distinguished from the other 21 subtribes (*Putranjiva* is contained in the second subtribe Glochidiinae) only in the character of the inflorescence being spicate, racemose or paniculate (cf. Pax & Hoffman in Engler & Prantl, Pflanzenfam. Ed. 2. 19c: 31. 1931).

The systematic position of this new genus is an

interesting one, as it agrees with the Antidesminae of Pax in the male flowers being in spikelike racemes, yet it differs from it in the total absence of disks or glands in flowers of both sexes.

Formerly the genus *Putranjiva* contained four species and was considered as occupying a discontinuous area (cf. Pax & Hoffmann in l. c. 19c: 59. 1931). *Putranjiva roxburghii* Wallich is found in India, *P. zeylanica* Muell. Arg. in Ceylon, *P. matsumurae* Koidz. in the Liukiu Islands, and *P. integerrima* Koidz. in the Bonin Islands. In the present treatment the latter two species are transferred to *Liodendron*, as *L. matsumurae* (Koidz.) and *L. integerrimum* (Koidz.), respectively. In addition there is the Formosan species *L. formosanum*. These species show that *Putranjiva* and *Liodendron* occupy two separate natural phytogeographic regions, namely, *Putranjiva* in India and Ceylon and *Liodendron* in the Bonin and Liukiu Islands and in Formosa. The establishment of this new genus confirms the phytogeographical relationship between Formosa-Liukiu and the Bonin Islands.

The genus is named in honor of Dr. Hui-Lin Li, of the National Taiwan University, in appreciation of his extensive contributions to our knowledge of the flora of eastern Asia.

1. *Liodendron matsumurae* (Koidzumi), comb. nov.

*Putranjiva roxburghii* Wallich, misapplied by Matsumura in Bot. Mag. Tokyo 12: 61. 1898; Hayata in Journ. Coll. Sci. Univ. Tokyo 20(3): 25. pl. 2H. 1901.

*Putranjiva matsumurae* Koidzumi in Bot. Mag. Tokyo 33: 116. 1919, not Suzuki in Sylvania 4(3): 129. 1930, in Masamune, Short Fl. Formosa 122. 1936.

A species known only from the Liukiu Islands. S. Suzuki reports the presence of it in Formosa. Two of his cited specimens were examined, one, Taroko, Ariko-banti, Matsuda 1184, is a fruiting specimen of *Eleocarpus decipiens* Hemsley; the other, Kwasyoto, Kudo & Mori 1784, is nothing more than a sterile specimen of *Liodendron formosanum*.

LIUKIU ISLANDS: Herb. No. 22377 (fruiting fragment presented by the herbarium of Tokyo Imp. Univ., collector and date unknown); Amami-Osima, Tashiro 27737.

2. *Liodendron integerrimum* (Koidzumi), comb. nov.

*Putranjiva integerrima* Koidzumi in Bot. Mag.

Tokyo 33: 117. 1919; Nakai in Bull. Biogeogr. Soc. Japan 1: 259. 1930.

A species known only from the Bonin Islands.

3. *Liodendron formosanum* (Kanehira & Sasaki), comb. nov.

*Putranjiva formosana* Kaneh. & Sasaki in Sasaki, Cat. Gov. Herb. Formosa 312. 1930, nomen; Simada in Trans. Nat. Hist. Soc. Formosa 24: 83. 1934; Suzuki in Masamune, Short Fl. Formosa 122. 1936.

*Drypetes formosana* (Kaneh. & Sasaki) Kanehira, Formos. Trees, rev. ed., 336. f. 929. 1936.

*Putranjiva roxburghii* Wallich, misapplied by Hayata, l. c. 25. 1904, as to Formosan plants.

*Putranjiva matsumurae* Koidzumi misapplied by Suzuki in Sylvania 4(2): 129. 1933 in Masamune, Short Fl. Formos. 122. 1936, as to Formosan plants.

Small tree, the branches slender, terete, glabrous, the branchlets sulcate, obscurely pubescent. Leaves elliptic to oblong-ovate, 5-8 cm long, 3-5 cm wide, the apex acuminate, the base obliquely acute, membranaceous at first, later coriaceous, the margins entire to crenulate-serrulate; petioles 7 mm long. Male flowers spicate-racemose, axillary, 6-8 cm long, velutinous; bracts 2-3-flowered. Female flowers in bud elliptical, shortly pedicellate, 1 mm long; sepals 4-6, unequal, hispid, imbricate; stamens 2; mature female flowers not seen. Drupe ovoid-ellipsoid, 10-13 mm long, 7-8 mm across, appressed white-pubescent, 1-locular, 1-seeded.

A species known only from Formosa.

TAIWAN: Sinchashek, Sinchu, Kanehira & Sasaki 27130 (syntype of *Putranjiva formosana* Kaneh. & Sasaki); Sasaki 7292, September 21, 1927; Chukong, Sinchu, Sasaki 7291, January 1927; Komo, Sinchu, Kudo & Sasaki 140 (type of ♂ inflorescence), April 9, 1929.

The following specimens are sterile, the size of the leaves being larger than the normal forms, and they are probably taken from the lower branches or basal sprouts: Sizangan, Taipei, Nonaka & Kudo 2391; Kizan, Taipei, Masamune & Suzuki 2393; Hoshautau, Kudo & Mori 1784; Botel Tobago, Hosokawa 3186.

Kanehira and Sasaki first proposed this species as *Putranjiva formosana*. Six years later Kanehira transferred it into *Drypetes formosana*, but such characters as the two stamens in the male flower, the 1-celled, 1-seeded fruit, and the male

flowers being in spikelike racemes readily separate it from *Drypetes*. In the latter, the stamens are 2-4, the fruits are 2-4-celled, 2-seeded, and the male flowers are clustered and axillary.

This species is clearly related to *Liodendron matsumurayae*, yet it may be readily separated by the larger leaves and smaller fruits. The latter species has elliptic-oblong leaves, 4-6 cm long, 2-3.5 cm wide, and ovoid fruits, 1.5-2 cm long, 0.8-1.3 cm wide, and is confined to the Liukiu Islands.

#### *Drypetes* Vahl.

1. *Drypetes falcata* (Merr.) Pax in Engler, Pflanzenz. **81** (VI.147.XV): 250. 1922.

*Cyclostemon falcatus* Merr. in Philippine Journ. Sci. **3**: 415. 1908; Enum. Philippine Fl. Pl. **2**: 406. 1923.

*Drypetes yamadai* Kanehira & Sasaki in Trans. Nat. Hist. Soc. Formosa **21**: 145. 1931, nomen seminud.; Kanehira, Formos. Trees, rev. ed., 339. f. 293. 1936; Suzuki in Masamune, Short Fl. Formosa 119. 1936. (New synonym.)

Taiwan; Hengchun Peninsula, in thickets and forests along the seashore.

TAIWAN: Kuraru, *Yamada 14573* (syntype of *D. yamadai*, FRI); *Konishi 14574* (FRI); *Matuda 112*; Olungbi, *Hibino & Suzuki 12586*, *12702*; *Kimiya 14575* (FRI); *Kudo & Suzuki 15815*; *H. Keng 1394*.

There is not sufficient difference between *D. yamadai* and *D. falcata* to treat them as distinct species. Kanehira states (in Trans. Nat. Hist. Soc. Formosa **21**: 145. 1931) that the former is "very near *Cyclostemon falcata* Merr., but differs in having glabrous fruits." However, after examining the syntype and a fruiting specimen from the type locality, *Matuda 112*, I find that the fruit is appressed-pubescent, rather than glabrous. In Merrill's original description, it is stated: "Fructus axillares, solitarii, pedicellis 5-7 mm longis." In Formosan plants the fruits are solitary or rarely 3-4-clustered and the fruit-stalks are usually 1 cm long, sometimes up to 1.5 cm long.

*D. falcata* in the Philippines is known only from Camiguin, a small island of the Babuyan group, situated between Taiwan and Luzon.

#### *Daphniphyllum* Blume

1. *Daphniphyllum crispifolium*, sp. nov.

Folia elliptica vel oblongo-elliptica, 8-10.5

cm longa, 2.5-4 cm lata, apice obtusa, apiculata, basi obtusa vel acuta, spura nitida, subtus papillosa, subglaucosa, margine valde crispa. Racemi fructiferi 7-8 cm longi. Fructus oblongo-ellipsoideus, 7-8 mm longus, 5-6 mm latus, rugosus, stigmatibus valde circinatis, pedicellis gracilibus 1-1.5 cm longis.

TAIWAN: Nichtigetzuan, Taichung, *Kudo & Sasaki 15336a*, *15336b* (type), September 19, 1929.

This species is near *D. oldhamii* Rosenth., differing in the strongly crisped leaf-margins, the longer and more slender fruiting inflorescences and the smaller fruits.

2. *Daphniphyllum reticulatum*, sp. nov.

Folia tenuiter coriacea, obovato-elliptica vel elliptica, 8-9 cm longa, 3-3.5 cm lata, apice cuspidato-obtusa, basi acuta, supra nitida, subtus papillosa, nervis lateralibus untrinsecus 10-20, angulo circiter 60° ortis, rete venularum subtus insigniter prominulo, nervis venisque supra impressis vel prominulis, subtus prominentibus. Racemi fructiferi 6 cm longi. Fructus ellipsoideo-ovideus, circiter 8 mm longus et 5 mm latus, basi et apice rotundatus, apice stigmatiferus, revolutus, pubescens; pedicellis 4-5 mm longis.

TAIWAN: Taroko, Hualien, *S. Suzuki 9880* (type), December 30, 1931; Hengchun, Mount Hiirasan, *E. Matuda 919*; Kuskus, *Kudo & Suzuki 15947*.

A species characterized by the finely reticulate veinlets very prominent on the lower surface of the leaves and by the very short fruiting stalks.

3. *Daphniphyllum formosanum*, sp. nov.

Frutex, ramulis subgracilibus. Folia coriacea, oblonga vel oblongo-elliptica, 4-7 cm longa, 2-2.5 cm lata, apice acuta, apiculata, basi late cuneata, supra nitida, subtus papillosa, costa plana, subtus prominente elevata, nervis lateralibus untrinsecus 12-15, margine subintegra, revoluta vel crispa, petiolis 1.2-2 cm longis, supra leviter canaliculatis. Racemi fructiferi 4-5 cm longi, graciles. Fructus ovideus, 7-9 mm longus, apice rotundatus, basi acutus, stigmatibus circinatis, persistentibus, calyce basi adnata, 5-dentata, lobis lineari-lanceolatis, crenatis, saepius persistentibus.

TAIWAN: Hikizangan, Taipei, *T. Suzuki 4814*, July 26, 1932; Gukutu, Hualien, *E. Matuda 1155* (Type), August 5, 1918; Nainbuntoge, Kaoshiung, *Kudo & Suzuki 1615*, April 10, 1930.

This is the only known species in Formosa with persistent calyx in the fruiting stage. All its characters agree well with that of *D. marchadii* Croizat and Metcalf (in *Lingnan Sci. Journ.* **20**: 117. 1942) or *D. salicifolium* Chien (in *Contr. Biol. Sci. Soc. China* **8**: 242. 1933) of southwestern China, except the much smaller fruits and the longer, circinate stigmas. No authentic specimens of the latter species have been seen. This new species may also be readily separated from *D. oldhamii* by its smaller leaves with prominent apicules at the apex and by the persistent calyx at the base of the fruit.

#### *Mercurialis* Linn.

1. *Mercurialis leiocarpa* Sieb. & Succ. var. *transmorrisonensis* (Hayata), comb. nov. *Mercurialis leiocarpa* Sieb. & Zucc., misapplied by Hayata in *Journ. Coll. Sci. Univ. Tokyo* **25**: 194. 1908. S. Suzuki in *Sylvia* **4**: 143. 1933, in Masamune, *Short Fl. Formosa* 122. 1936.

*Mercurialis transmorrisonensis* Hayata, *Icon. Pl. Formosa* **5**: 199. f. 75. 1915.

Taiwan; throughout the island, more common in the central mountain regions.

TAIWAN: Mount Kanin, *Fukuyama* 34; Mount Taiping, *S. Suzuki* 383, 3839; Mount Tentana, *Simada* 14992 (FRI); Mount Arisan, *Simada* 796; Mount Dabusan, *Sasaki* 2144, *Matuda* 1500; Ariko-banti, *Matuda* 1199; Pintung, *Hosokawa* 5408; Taroko, *S. Suzuki* 9684; Mount Nokosan, *Fukuyama* 4682.

The typical form of the species is distributed in Indo-China, Siam, southern China (Yunnan to Hupeh), and Japan. Hayata describes this variety as an independent species and states that it is "very near *M. leiocarpa* Sieb. & Zucc., but differs from it in having less verrucose ovary with the much spreading stigma and the less verrucose or nearly smooth capsules; the distinction of this plant from *M. leiocarpa* is even more clear in the living specimen." The actual distinctive characters of this Formosan plant are probably in the stamens. The stamens in the typical form are 16-20 (cf. Muell. Arg.) or 14-20 (cf. Pax), whereas in this variety there are only about 10. Furthermore, in this variety the filaments are usually 2-3-connate at the base, showing the tendency to monadelph.

#### *Alchornea* Swartz

1. *Alchornea trewioides* (Benth.) Muell. Arg. var. *formosae* (Muell. Arg.) Pax in Engler,

*Pflanzenr.* **63**: (IV. 147. VIII) 248. 1914. *Alchornea kelungensis* Hayata, *Icon. Pl. Formosa* **9**: 103. 1920; Kanehira, *Formosa Trees*, rev. ed., 329. 1936; S. Suzuki in Masamune, *Short Fl. Formosa* 118. 1936. (New synonym.)

TAIWAN: Taipei, *Sasaki* 14423; Keelung, *Matuda* 1144, *Simada* 1145.

This variety differs from the typical form of the species from southern China chiefly in the shorter (6-8 mm long) and usually 2-3-lobulate styles. In the typical form, the styles are longer (8-12 mm) and entire at the apex.

2. *Alchornea trewioides* (Benth.) Muell. Arg. var. *lochoensis* (Hayata), comb. nov. *Alchornea lochoensis* Hayata, *Icon. Pl. Formosa* **9**: 103. 1920. *Alchornea trewioides* Muell. Arg., misapplied by Hayata in *Journ. Coll. Sci. Univ. Tokyo* **23**: 47. pl. 4A. 1904.

LIUKIU ISLANDS: Guo-teu, *Kanesiro* 195; Yu-na-guo-tau, *Simada* 14424 (FRI).

This variety can be distinguished from var. *formosae* by the following characters in the female flowers: the lanceolate-acuminate sepals, the globose ovary and the much shorter styles (3 mm long); whereas in the Formosan plants, the sepals are triangular-acuminate, the ovary is depressed globose, and the styles are somewhat longer (6-8 mm long).

#### *Acalypha* Linn.

1. *Acalypha* (Sect. *Capillipes* Muell. Arg.) *hontauyuensis*, sp. nov.

Frutex; ramuli sericeo-tomentosi, consperse sulcati. Folia tenuiter chartacea, longe petiolata, cordato-orbiculata, 12-18 cm longa, 12-16 cm lata, apice cordato-acuminata, basi oblique truncato-cordata, margine crenato-serrata, 5-nervia, utrinque subglabra et ad costam nervosque dense hirsuta, petioliis 8-20 cm longis, gracilibus, sericeo-tomentosis. Spicae fl. ♂ ignotae. Spicae fl. ♀ gracillimae, axillares, solitariae, 6-10 cm longae, pedunculis 0.5-2 cm longis, hirsutis, floribus remotis spicatis, sessilibus, lanceolatis, 3-4 mm longis, hirsutis. Fl. ♀: bractea unica minuta, triangularis, 1 mm longa, extus densissime hirsuta; sepala 3, ovata, 1 mm longa, intus concava, subglabra, extus hirsuta; styli 2.5-3 mm longi, graciles, glabri.

TAIWAN: Hontauyu (Botel Tobago), *Hosokawa* 8047 (type), July 4, 1935; *Hosokawa* 8165, July 16, 1935.

This species and *A. suirenbiensis* Yamamoto are characterized by the sessile female flowers with very minute and nonacrescent bracts, while in the other species of the genus the female flowers when sessile are generally provided with large and showy bracts, usually enclosing the mature capsules.

**Euphorbia** Linn.

1. **Euphorbia** (Sect. *Tithymalus* Boiss.) **shou-anensis**, sp. nov.

Caules villosi, crassi, erecti. Folia sessilia, membranacea, uninervia, lineari-oblonga vel lineari-lanceolata, 2-5 cm longa, 8-14 mm lata, apice acuta, basi attenuata, subtus pubescentia. Umbellaria primaria ovato-lanceolata, 2.5-5 cm longa. Triplo cymae terminales. Involucrum centrale campanulatum, stipitatum, 3.5 mm longum, 2.5-3 mm diametro, extus glabrum, intus hirtellum, lobis 4 (5 ?), ovato-oblongis, ciliatis, glandulis 4, transversis, reinformibus, stipitatis. Flores ♂ 12, bracteolis spathuliformibus, insertis, margine apicem versus densissime pilosis. Flores ♀ pedicellis elongatis, exserti; ovarium ovoideo-globosum, 2 mm longum, trisulcatum, glandulis verrucosis compressis brevibus conicis obtusissimis obsitum, stylis 3, 2 mm longis, basi brevissime connatis, apice breviter bifidis, stigmatibus subincrassatis. Involucrum sterile 2 mm longum, 1.5 mm diametro; ovarium minutum.

TAIWAN: Shashan, Shouan, Chiayi, Tainan, altitude 1,500 m, *T. Suzuki 20910* type), November 10, 1940.

This species is distinctly characterized by the triplo-cymose inflorescence and the involucreal structures. In primary cymes, the umbellate leaves are 5, ovate-lanceolate, 2-5 cm long, 1.5 cm wide and with acute apex; the umbellate branches are 5, the central one being much shorter. In secondary cymes, the umbellate leaves are 3, ovate-rounded, 1.5 cm long, 1 cm wide and with very obtuse apex; the umbellate branches are 3. In tertiary cymes, the umbellate leaves are 3, subrounded, 8 mm long and 7 mm wide. The central fertile involucre is single, naked, campanulate, stalked, 3.5-4 mm long

and 2.5-3 mm in diameter. Lateral sterile involucre are 3, turbinate, 2 mm long, 1.5 mm in diameter and short-stalked, each concealed in 2 clasping floral leaves (or bracts) opposite to the tertiary umbellate leaves.

In the central fertile involucre, the lobes are 4 (5 ?) ovate-oblong, the glands are 4, transversely reniform, and substalked. Male flowers are about 12. The ovary is ovoid-globose, exserted, and the styles are nearly free except at the very base. In lateral sterile involucre, the lobes and glands are not very distinct, the rudimentary flowers are numerous and the rudimentary ovary is included.

2. **Euphorbia prostrata** Ait., Hort. Kew. 2: 136. 1789; Bernard, Icon. Bogor. 4: 51. pl. 316. 1916; Merr., Enum. Philippine Fl. Pl. 2: 463. 1928.

*Euphorbia liukiensis* Hayata, misapplied by Sasaki, Cat. Gov. Herb. Formosa 305. 1930; Suzuki in *Sylvia* 4: 155. 1933, in Masamune, Short, Fl. Formosa 119. 1935.

*Chamaesyce liukiensis* (Hayata) Hara in Journ. Jap. Bot. 14: 356. 1938.

Taiwan, distributed nearly throughout the whole island, pantropical.

TAIWAN: Northern part, *S. Suzuki 12414, 12257, Masamune & Suzuki 1742, Mori 8379, Simada 1733, 1736, 3211, Sasaki 1741*; southern part, *Simada 14678 (FRI), Mori 101, Hosokawa 1939, 1941*; eastern part, *S. Suzuki 1277, 1667, 10607*; Pescadores, *Kudo & Mori 3070, Cheng 3071*.

This is a new record for the flora of Formosa. This species is similar in general appearance to *E. thymifolia*, but it may be distinguished from the latter by the longer stalks of the involucre, the more prominent persistent columnella of the cocci, the shorter stalks of the glands, and the less hirsute cocci.

I have not seen the type of Hayata's *E. liukiensis*, a species of Liukiu. However, the four specimens deposited in the herbarium of the Taiwan Forestry Research Institute, i.e., *Hirata 14676, Soma 14677, Simada 14678, and Yasukawa 14679*, all from Taiwan and determined by S. Sasaki as doubtfully of this species, agree exactly with *E. prostrata*.

ZOOLOGY.—*New distributional records for two athecate hydroids, Cordylophora lacustris and Candelabrum sp., from the west coast of North America, with revisions of their nomenclature.* CADET HAND, Mills College, Oakland, and University of California, Berkeley, and G. F. GWILLIAM, University of California, Berkeley. (Communicated by F. M. Bayer.)

#### I. CORDYLOPHORA

In August 1950 an unidentified hydroid was found in a collection at the University of California at Berkeley. The label bore no collection date or collector's name, but it did report the locality from which the animal was taken as Antioch, Calif., which is located on the San Joaquin River 5 miles upstream from its junction with the Sacramento River. The hydroid was subsequently identified as the widely distributed fresh- and brackish-water form, *Cordylophora lacustris* Allman.

On August 26, 1950, the writers found this hydroid growing on pieces of old manila rope suspended from a floating dock in the San Joaquin River at Antioch. The ropes were literally covered with colonies of varying sizes. A sample of the river water taken at this time showed a chlorinity of 1.02 parts per thousand (5.4 per cent of sea water).

What appears to be the first recognizable description of this hydroid was that of Allman (1844), who found it in the docks of the Grand Canal, Dublin, Ireland. Roch (1924) in a paper dealing with many aspects of the biology of this hydroid reviewed its distribution, listing the following general localities in which *Cordylophora* occurred: Germany, Holland, Denmark, Sweden, Finland, Esthonia, Courland (now part of Lithuania), Russia, France, Belgium, England, Ireland, United States, Brazil, Egypt, Australia, Tasmania, New Zealand, China.

In North America, Leidy (1870) first detected this hydroid at Newport, R. I., and later in the vicinity of Philadelphia, Pa. Since that time *C. lacustris* has been found in several localities in North America, some of them a considerable distance inland.

Fraser (1944, p. 35) reports the American distribution as: "Newport, R. I. (Leidy); St. Andrews, Gaspé, Seven Islands (Stafford); New England (Kingsley); Woods Hole (Nutting); several ponds near Woods Hole, Marthas Vineyard (Hargitt); Miramichi estuary, Frenier Beach, La. (Fraser);

Gatun locks, Panama canal." In addition, Ward and Whipple (1945) list the following: Illinois River at Havana, Ill.; Mississippi River at Granite City and at East St. Louis, Ill.; Arkansas River at Little Rock, Ark.; and the Red River at Shreveport, La.

The present report is the first record of the existence of this organism on the west coast of North America. This was not entirely unexpected, as Fraser (1946, p. 101) stated: "It has not yet been reported from the eastern Pacific, but it has extended along the whole length of the North American Atlantic, and as it has entered the Panama canal as far as the Gatun locks, it may show up in the Pacific before long."

Several varieties of *C. lacustris* have been described. Schulze (1921) mentions the forms *albicola*, *transiens*, and *whiteleggei*. Fyfe (1929) described a new subspecies (*otagoensis*) from New Zealand. Earlier Leidy (1870) gave to what he recognized as a small variety of *C. lacustris* the name *C. americana*. Briggs (1931) points out that *C. lacustris* is extremely variable in growth form and that growth form may depend upon salinity. It appears that all the named subspecies and forms of *C. lacustris* are nothing more than variations in habit. The present writers have found such extensive variation in the specimens studied that the recognition of named varieties seems to have no taxonomic significance.

There is some doubt as to whether the proper specific name of *Cordylophora* is *lacustris* or *caspia*. Pallas (1771) described a hydroid from the Caspian Sea as *Tubularia caspia*. This is said by some to be identical with *C. lacustris* Allman (Roch, 1924; Cordero, 1941). Other writers feel that Pallas' description is too vague to permit an exact diagnosis (Briggs, 1931; Bedot as quoted by Briggs) and prefer to retain *C. lacustris*.

The present writers have studied the Pallas description and find it so generalized that it might as well refer to many other

hydroids as to *C. lacustris*. Further, there seem to be no valid records of this hydroid from the Caspian Sea since the time of Pallas. Because of this, coupled with the fact that *C. lacustris* Allman has had such wide usage, the present writers choose to retain Allman's name until it can be clearly shown that *Tubularia caspia* Pallas is identical with *Cordylophora lacustris* Allman.

Another nomenclatural problem is brought up by Finlay (1928). Finlay declares that the family Clavidae to which *Cordylophora* belongs is an invalid name due to preoccupation by the gastropod genus *Clava* Martyn (1784) over the hydroid genus *Clava* Gmelin (1791). Finlay suggests that the name Clavidae be replaced by the name Cordylophoridae, *Cordylophora* being the next available generic name. This solution changes the type genus of the family, an action for which there is no valid taxonomic reason, and, further, Finlay fails to reassign the species of *Clava* (the hydroids) to any other genus. In considering this matter it has been pointed out to us by Dr. H. A. Rehder, curator of mollusks, U. S. National Museum, that the system used by Martyn in his "Universal Conchologist" is non-Linnaean, and that Martyn's names are therefore not available and do not pre-occupy. The change suggested by Finlay (*op. cit.*) was therefore unnecessary, and the hydroid genus *Clava* Gmelin (1791) stands as the valid type of the family Clavidae.

Material from the University of California collection (U.S.N.M. no. 49727), the San Pablo Reservoir, and fresh material from Antioch (U.S.N.M. no. 49726) has been carefully examined and compared and no characters separating these from *C. lacustris* have been found.

#### Family CLAVIDAE

Genus *Cordylophora* Allman, 1844

*Cordylophora lacustris* Allman

*Colony*: Growth form variable. Sometimes a main axis with hydranths given off alternately, sometimes more diffuse and irregular, or colony branched, lacking a main axis. Hydrocaulus arising from creeping hydrorhizae. Perisarc well developed. Longest hydrocaulus observed approximately 6 cm.

*Trophosome*: Hydranth clavate, pedicellate,

with up to 30 scattered, filiform tentacles. Perisarc at bases of pedicels often annulated, but occasionally smooth or "corrugated" on one side only. Perisarc extending only to base of hydranth. Tentacles quite extensile, mouth terminal. Nematocysts; desmonemes (4.0-6.0 by 3.0-4.0 $\mu$ ) and microbasal euryteles (7.5-11.0 by 4.0-4.5 $\mu$ ).

*Gonosome*: Dioecious. Sporosacs sessile or borne on short pedicels which may or may not be annulated at their bases as in trophosome. Gonophores enclosed in a thin perisarc, and arise from hydrocauli or pedicels. In the female the eggs are extruded from the generative tissue into a jelly-like mass. The generative tissue regresses as the eggs are extruded, finally leaving a variable number (approximately 1-8) of recognizable ova. At this site the ova develop into planulae and are then released. In general, the female gonophores tend to be more spherical than the male. In life female gonophores pinkish, male whitish.

*Habitat and distribution*: On sticks, ropes, floating docks, etc. in fresh or brackish water. In California, *C. lacustris* occurs at Antioch, and has been reported from Lake Merced, San Francisco (Dr. R. C. Miller, California Acad. Sci., personal communication) and from the San Pablo reservoir system, El Cerrito, California (Dr. H. Kirby, Jr., Univ. California, Berkeley, personal communication). Also, according to Dr. T. Kincaid, Univ. Washington, Seattle (*in litt.*) this species occurs in the Puget Sound area. It has evidently been in California for a number of years. The old University of California specimen mentioned above is thought to be 20 to 40 years old.

#### II. CANDELABRUM

On May 6, 1950, three specimens of *Candelabrum* sp. (= *Myriothela* sp.) were collected from a pholad hole on the under-surface of a rock at approximately the zero foot tide level (mean lower low water) at Pigeon Point, San Mateo County, Calif. The authors do not feel that this is sufficient material to warrant specific identification, especially since none of the polyps bear mature gonophores. Several attempts were made to obtain more material, but thorough searching has failed to reveal the presence of further specimens. It may be that it is a stray in the intertidal zone and exists in numbers subtidally. Some indication of this may be gained from the fact that several

of the known species of *Candelabrum* are subtidal forms. Of the generic identification, we feel that there is no doubt.

As nearly as the authors have been able to determine there are now nine valid species of this genus. The first was described as *Lucernaria phrygia* by Fabricius (1780). This was later redescribed by Sars (1850), apparently unaware of Fabricius' description, as *Myriothele arctica*. De Blainville (1830; reprinted, 1834) realized that Fabricius' animal was not a *Lucernaria* and proposed the name *Candelabrum* for it. He indicated at the same time that it was related to the Sipunculids. Allman (1872, p. 381) states: "De Blainville, seeing that Fabricius' animal had no relation with *Lucernaria*, constituted for it, in 1834, his genus *Candelabrum*, and as this name has priority over *Myriothele*, it is accepted by Agassiz as the legitimate name of the genus." Allman goes on to explain that De Blainville did not recognize its true affinities, while Sars did. He chooses to retain *Myriothele* Sars in spite of the law of priority, an action that the present authors do not deem justified. The replacement of the name *Myriothele* by *Candelabrum* necessitates the renaming of this monogeneric family, which we now designate as the Candelabridae (= Myriotheleidae Allman).

In addition to *Candelabrum phrygium*, the other known species and the localities from which they were taken are: *C. mitrum* (off coast of Norway near Bergen, deep water, Bonnevie, 1898); *C. minutum* (near Tromsø, Norway, intertidal?, Bonnevie, 1898); *C. verrucosum* (locality not given, Bonnevie, 1898); *C. giganteum* (Greenland Sea, deep water, Bonnevie, 1898); *C. austro-georgiae* (off Cumberland Bay, South Georgia Island, deep water, Jäderholm, 1904); *C. cocksii* (Falmouth, England, intertidal, Cocks, 1849, as a nomen nudum; Cocks, 1853, name validated); *C. harrisoni* (New South Wales, Australia, intertidal, Briggs, 1928); *C. australe* (New South Wales, Australia, intertidal, Briggs, 1928).

Fraser (1946, p. 168) reports that only one species is known from North America (*C. pyrgium*) and states concerning it: "The only American location so far reported is off Grand Manan Island, at the mouth of the bay of Fundy, but its range extends

eastward by way of Greenland and Iceland to Great Britain, Norway, Nova Zembla, and the Siberian Polar Sea."

Family CANDELABRIDAE, nom. nov.

Genus *Candelabrum* de Blainville, 1830

*Candelabrum*, sp. ind.

U. S. N. M. no. 49725.

*Hydranth*: Not branched, solitary, naked and arising from a creeping hydrorhiza or possibly a disc. Hydrorhizae invested with perisarc. Exclusive of hydrorhizae, polyp divisible into two zones; a distal tentacle-bearing zone and a proximal tentacle-free blastostylar zone. The tentacle-bearing zone composes five-sixths or more of the polyp length and bears approximately 500 tentacles in the adult; cylindrical, approximately the same diameter throughout. Tentacles densely packed, short, capitate and not arranged in any discernible pattern. Mouth terminal. Blastostylar zone swollen, of a slightly greater diameter than the tentacle bearing zone. Sometimes separated from tentacle-bearing zone by a constriction; at the proximal end tapering sharply to hydrorhiza. Structures referred to by Allman (1875) as "claspers" not present on specimens examined. Blastostyles giving rise to more than one gonophore. Largest specimen (preserved) 2.5 cm long by 0.15 cm. in diameter (including the tentacle.)

Of the known species of *Candelabrum*, the species described above most closely resembles *Candelabrum harrisoni* Briggs. In fact there are no obvious differences, but in view of the unusual distribution which Briggs' species would then have, plus the paucity of material available, it does not seem wise to make the two conspecific at this time.

LITERATURE CITED

- ALLMAN, G. J. *Synopsis of the genera and species of zoophytes inhabiting the fresh waters of Ireland*. Ann. Nat. Hist. (1) **13**: 328-333. 1844.
- . *A monograph of gymnoblastic or tubularian hydroids* **2**: 381-383. 1872.
- . *On the structure and development of Myriothele*. Phil. Trans. Roy. Soc. London **165** (2): 549-572. 1875.
- BLAINVILLE, H. M. D. DE. *Dictionnaire des sciences naturelles* **60**: 284. 1830.
- . *Manuel d'actinologie*. Paris, 1834.
- BONNEVIE, K. *Zur Systematik der Hydroiden*. Zeitschr. für Wiss. Zool. **63**: 465-493. 1898.
- BRIGGS, E. A. *Studies in Australian athecate hydroids*. Rec. Austral. Mus. Sydney **16**: 305-315. 1928.



- . *Notes on Australian athecate hydroids*. Rec. Austral. Mus. Sydney. **18**: 279-282. 1931.
- COCKS, W. P. *Contributions to the fauna of Falmouth*. Ann. Rep. Roy. Cornwall Polytech. Soc. **17**: 38-102. 1849.
- . *Contributions to the fauna of Falmouth, 1853*. Ann. Rep. Roy. Cornwall Polytech. Soc. **21**: 28-36. 1853.
- CORDERO, E. H. *Observaciones sobre algunas especies sudamericanas de género Hydra*. II. *Hydra y Cordylophora en el Uruguay*. Ann. Acad. Brasil. Sci. **13**: 173-184 figs. 1-26. 1941.
- FABRICIUS, O. *Fauna Groenlandica*. 1780.
- FINLAY, H. J. *Notes on New Zealand and Australian gymnoblastic hydroids*. Austral. Zool. **5**: 257-261. 1928.
- FRASER, C. M. *Hydroids of the Atlantic coast of North America*. Toronto, 1944.
- . *Distribution and relationship in American hydroids*. Toronto, 1946.
- FYFE, M. *A new fresh water hydroid from Otago (New Zealand)*. Trans. Proc. New Zealand Inst. **59** (4): 813-823. 1929.
- GMELIN, J. F. In Linnaeus, *Systema naturae*, ed. 13, 1(6): 3131. 1791.
- JÄDERHOLM, E. *Mitteilungen über einige von der Schwedischen Antarctic-Expedition 1901-1903 eingesammelte Hydroiden*. Arch. Zool. Exp. et Gen. Notes et Revue, ser. 4, **3** (1): i-xiv. 1904.
- LEIDY, J. [The Proceedings, Oct. 18, 1870.] Proc. Acad. Nat. Sci. Philadelphia **22**: 113. 1870.
- MARTYN, T. *Universal conchologist* **1**: fig. 12. 1784.
- PALLAS, P. S. *Reise durch verschiedene Provinzen des Russischen Reichs* **1**(5): 1-504, 24 pls. St. Petersburg, 1771.
- ROCH, F. *Experimentelle Untersuchungen an Cordylophora caspia (Pallas) etc.* Zeitschr. Morph. und Ökol. Tiere. **2**: 350-426; 667-670. 1924.
- SARS, M. *Beretning om en i Sommeren 1849 foretagen Zoologisk reise i Lofoten og Finmarken*. Nyt. Mag. Naturvid. Christiania **6**: 121-211. 1850.
- SCHULZE, P. *Die Hydroiden der Umgebung Berlins mit besonderer Berücksichtigung der Binnenlandformen von Cordylophora*. Biol. Zentralbl. **41**: 211-237. 1921.
- WARD, H. B., and WHIPPLE, G. C. *Fresh water biology*. New York, 1945.

ZOOLOGY.—*The diplopod family Campodesmidae (Polydesmida)*. RICHARD L. HOFFMAN, Clifton Forge, Va. (Communicated by E. A. Chapin.)

The name Campodesmidae was proposed in 1895 by O. F. Cook. Appearing in a key to the tropical African families of polydesmoid millipeds, the original description was rather inadequate. Subsequently, in several publications cited below, additional information (of a fragmentary nature) was given about the family and its two genera, but later workers have never been able to derive a very satisfactory idea of the nature of the group. It is a matter of some interest that campodesmids have never been encountered by other workers, who have managed to come across most of the other West African genera described by Cook.

Since the great majority of Cook's Liberian species have never been adequately described and have been mostly ignored by later workers, it appears necessary to re-describe them. Through the unflinching cooperation of Dr. E. A. Chapin, I have been able to study the Cook collection now in the U. S. National Museum. The present paper, the first of a planned series, is concerned with the campodesmids and with the systematic position of the family.

#### Family CAMPODESMIDAE Cook

Campodesmidae Cook, Proc. U. S. Nat. Mus. **18**: 82. 1895; Amer. Nat. **30**: 414. 1896.

*Diagnosis*.—Male gonopods large, prominent, protruding from a large oval sternal aperture. Coxae subcylindrical, attached loosely to each other, largely concealed within the aperture. Prefemur small, with a large unbranched laminate prefemoral process. No distinction between femur and tibiotarsus, the latter distally elongate, slender, forming nearly a complete circle.

Gnathochilarium and mandibles typical of the usual polydesmoid form.

Antennae of moderate heaviness, with a few scattered hairs. Four sensory cones, concealed within the seventh article.

Head finely granular, with a well-defined vertical groove. A prominent ovoid longitudinal swelling immediately under each antennal socket. Clypeal area much swollen, raised above level of frons, glabrous.

Collum rather small, not concealing the head and much exceeded in width by the keels of the second segment.

Keels of midbody segments well developed, wide as body cavity but narrow and widely

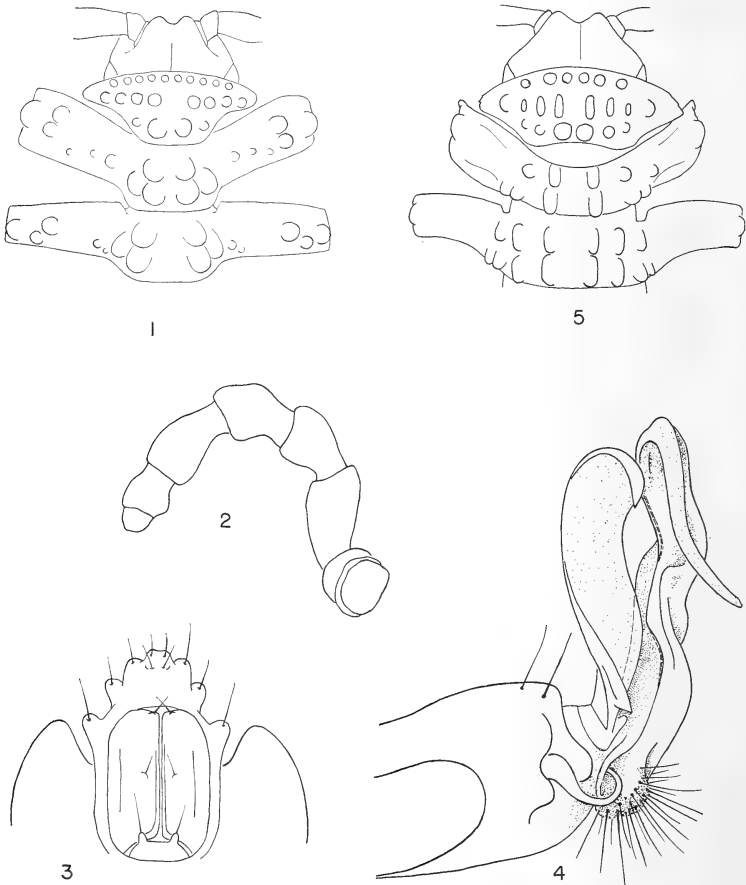

FIGS. 1-5.—1, *Campodesmus carbonarius*, dorsal view of head and first three segments; 2, same, antenna, much enlarged; 3, ventral view of last two segments; 4, left male gonopod, mesial aspect; 5, *Tropidesmus jugosus*, dorsal view of head and first three segments. Figures drawn to different scales.

separated from each other. Keels strongly depressed causing tergites to be highly arched.

Repugnatorial pores small, not on special stalks, occurring only on segments 5 and 7.

Anal segment large, not concealed by nineteenth, with three large tubercles on each side, distally bent slightly downward.

Preanal scale small, trapezoid, with two elongate setiferous tubercles. Anal valves nearly plane, each with a median tubercle.

Sternites rather broad and smooth, without special modifications.

Legs of moderate length and size, without spines, lobes, or tarsal pads.

Pleurites without carinae or large tubercles.

*Range*.—Known only from Liberia.

*Genera included*.—Two, which may be separated as follows:

1. Tergites each with a cluster of three elongate upright tubercles on each side of middle.

*Campodesmus*

Tergites each bearing two transverse rows, each of six short longitudinal carinae.

*Tropidesmus*

Genus *Campodesmus* Cook

*Campodesmus* Cook, Proc. U. S. Nat. Mus. **18**: 82. 1895.

*Genotype*.—*C. carbonarius* Cook, by monotypy.

*Diagnosis*.—With the characters of the family, particularly distinguished by the ornamentation of the tergites. Collum with a row of 10 small tubercles on the anterior margin; a second row of eight larger tubercles across the middle. On the caudal half are two still larger tubercles with a small one laterad to each. Tergites of midbody segments with a cluster of three tubercles on each side of middle, these largest at midbody and diminishing towards the ends. Each keel bears three rounded tubercles near the outer end and two small ones at the base.

*Campodesmus carbonarius* Cook

*Type specimen*.—U. S. Nat. Mus., adult male, collected at Mount Coffee, western Liberia, by O. F. Cook.

*Diagnosis*.—With the characters of the genus. Dorsal color dark brown, underparts whitish. Length, from 28 to 38 mm.

Male gonopods of the form represented in Fig. 4.

Genus *Tropidesmus* Cook

*Tropidesmus* Cook, Amer. Nat. **30**: 414. 1896.

*Genotype*.—*T. jugosus* Cook, by monotypy.

*Diagnosis*.—Differing from *Campodesmus* chiefly in the nature of the ornamentation and in size and shape of the collum, as illustrated. Also, the second segment is not as wide and is somewhat more bent anteriorly. Collum with six tubercles along the front margin; eight in the second row (of which those at the ends are rounded, the others elongate); and six tubercles in the third row, of which the middle two are much enlarged. Second segment with keels produced forward, partially embracing and subtending the collum; dorsally with four short middorsal carinae and smaller indistinct tubercles laterad. On following segments the dorsal carinae increase to 12, in two transverse rows of six each. A single large swelling at the end of each keel.

*Tropidesmus jugosus* Cook

*Type specimen*.—U. S. Nat. Mus. (adult male?)<sup>1</sup> collected at Mount Coffee, Liberia, by O. F. Cook.

*Diagnosis*.—With the characters of the genus. Size and color about the same as in *Campodesmus*. The male gonopods may be expected to present additional specific and generic characters.

SYSTEMATIC POSITION OF  
THE CAMPODESMIDAE

The campodesmids seem not to be closely related to any other of the African polydesmoid millipeds. The family clearly falls into the group for which Brolemann in 1916 proposed the name "Leptodesmina." This ensemble is characterized by the fact that the coxae of the male gonopods are only slightly attached together, are not attached to the sternal aperture, and are generally concealed within the body when at rest.

In Attems' most recent key to the polydesmoid families (1937), *Campodesmus* runs down to the family Leptodesmidae (properly Chelodesmidae, *vide* Hoffman, 1950). The

<sup>1</sup>The original description mentions an adult male. The vial of material sent to me was labeled "Type" but contained only immature specimens. Presumably the mature specimen was taken out and is for the present misplaced in the body of the Museum collection.

configuration of the gonopod certainly vindicates this allocation, as the large pre-femoral process occurs in nearly all of the South American chelodesmid genera. In other characters, however, no particular relationship can be observed. Rather some similarity is seen with the Platyrhacidae, a family occurring in the East Indies and in Middle America but unrepresented in the Ethiopian region. The chief platyrhacid features obtain in the broadened anal segment, subantennal swellings, and general appearance of the sternites.

The shape of the preanal scale and the dorsal sculpture are very reminiscent of certain genera (notably *Orodesmus*) of the Oxydesmidae, a small family occurring in Central and West Africa.

Considering the various developments of campodesmids which are duplicated in other families in different parts of the world, and the absence of any specialization such as pronounced sexual dimorphism, modifica-

tion of the legs of males, etc., I am for the present inclined to regard the Campodesmidae as representative of a generalized ancestral chelodesmoid stock, a supposition not unsupported by the present areal distribution of the families concerned.

#### LITERATURE CITED

- ATTEMS, CARL GRAF. *Fam. Strongylosomidae*. In *Das Tierreich*, Lief. **68**: 1-300. 1937.
- BROLEMANN, HENRI W. *Essai d'une classification des Polydesmiens*. *Ann. Soc. Ent. France* **84**: 523-608. 1916.
- COOK, ORATOR F. *East African Diplopoda of the suborder Polydesmoidea, collected by Mr. William Astor Chanler*. *Proc. U. S. Nat. Mus.* **18**: 81-111. 1895.
- . *A new diplopod fauna in Liberia*. *Amer. Nat.* **30**: 413-420. 1896.
- . *Summary of new Liberian Polydesmoidea*. *Proc. Acad. Nat. Sci. Philadelphia for 1896*: 257-267.
- HOFFMAN, RICHARD L. *The status of the milliped Chelodesmus marxi Cook, and of the family name Chelodesmidae*. *Proc. Biol. Soc. Washington* **63**: 185-188. 1950.

## Officers of the Washington Academy of Sciences

*President*.....NATHAN R. SMITH, Plant Industry Station  
*President-elect*.....WALTER RAMBERG, National Bureau of Standards  
*Secretary*.....F. M. DEFANDORF, National Bureau of Standards  
*Treasurer*.....HOWARD S. RAPPLEYE, U. S. Coast and Geodetic Survey  
*Archivist*.....JOHN A. STEVENSON, Plant Industry Station  
*Custodian and Subscription Manager of Publications*  
 HAROLD A. REHDER, U. S. National Museum

*Vice-presidents Representing the Affiliated Societies:*  
 Philosophical Society of Washington.....EDWARD U. CONDON  
 Anthropological Society of Washington.....WALDO R. WEDEL  
 Biological Society of Washington.....  
 Chemical Society of Washington.....JOSEPH J. FAHEY  
 Entomological Society of Washington.....FREDERICK W. POOS  
 National Geographic Society.....ALEXANDER WETMORE  
 Geological Society of Washington.....LEASON H. ADAMS  
 Medical Society of the District of Columbia.....  
 Columbia Historical Society.....GILBERT GROSVENOR  
 Botanical Society of Washington.....E. H. WALKER  
 Washington Section, Society of American Foresters.....WILLIAM A. DAYTON  
 Washington Society of Engineers.....CLIFFORD A. BETTS  
 Washington Section, American Institute of Electrical Engineers

FRANCIS M. DEFANDORF

Washington Section, American Society of Mechanical Engineers. RICHARD S. DILL  
 Helminthological Society of Washington.....L. A. SPINDLER  
 Washington Branch, Society of American Bacteriologists.....ANGUS M. GRIFFIN  
 Washington Post, Society of American Military Engineers.....HENRY W. HEMPLE  
 Washington Section, Institute of Radio Engineers.....HERBERT G. DORSEY  
 District of Columbia Section, American Society of Civil Engineers.....

*Elected Members of the Board of Managers:*  
 To January 1952.....W. F. FOSHAG, C. L. GAZIN  
 To January 1953.....C. F. W. MUESEBECK\*, A. T. MCPHERSON  
 To January 1954.....SARA E. BRANHAM, MILTON HARRIS\*

*Board of Managers*.....All the above officers plus the Senior Editor  
*Board of Editors and Associate Editors*.....[See front cover]

*Executive Committee*...N. R. SMITH (chairman), WALTER RAMBERG, H. S. RAPPLEYE,  
 J. A. STEVENSON, F. M. DEFANDORF

*Committee on Membership*.....L. A. SPINDLER (chairman), M. S. ANDERSON,  
 MERRILL BERNARD, R. E. BLACKWELDER, R. C. DUNCAN, G. T. FAUST, I. B. HANSEN,  
 D. B. JONES, DOROTHY NICKERSON, F. A. SMITH, HEINZ SPECHT, ALFRED WEISSLER

*Committee on Meetings*.....MARGARET PITTMAN (chairman), NORMAN BEKEDAHL,  
 W. R. CHAPLINE, D. J. DAVIS, F. B. SCHEETZ, H. W. WELLS

*Committee on Monographs:*  
 To January 1952.....J. R. SWALLEN (chairman), PAUL H. OEHSER  
 To January 1953.....R. W. IMLAY, P. W. OMAN  
 To January 1954.....S. F. BLAKE, F. C. KRACEK

*Committee on Awards for Scientific Achievement* (GEORGE P. WALTON, general chairman):  
 For the Biological Sciences.....G. H. COONS (chairman), J. E. FABER, JR.,  
 MYRNA F. JONES, F. W. POOS, J. R. SWALLEN

For the Engineering Sciences.....R. S. DILL (chairman), ARSHAM AMIRIKIAN,  
 J. W. MCBURNEY, FRANK NEUMANN, A. H. SCOTT

For the Physical Sciences.....G. P. WALTON (chairman), F. S. BRACKETT,  
 G. E. HOLM, C. J. HUMPHREYS, J. H. McMILLEN

For Teaching of Science.....B. D. VAN EVERA (chairman), R. P. BARNES,  
 F. E. FOX, T. KOPPANTI, M. H. MARTIN, A. T. MCPHERSON

*Committee on Grants-in-aid for Research*.....L. E. YOCUM (chairman),  
 M. X. SULLIVAN, H. L. WHITTEMORE

*Committee on Policy and Planning:*  
 To January 1952.....J. I. HOFFMAN (chairman), M. A. MASON  
 To January 1953.....W. A. DAYTON, N. R. SMITH  
 To January 1954.....H. B. COLLINS, JR., W. W. RUBEY

*Committee on Encouragement of Science Talent:*  
 To January 1952.....M. A. MASON (chairman), A. T. MCPHERSON  
 To January 1953.....A. H. CLARK, F. L. MOHLER  
 To January 1954.....J. M. CALDWELL, W. L. SCHMITT

*Representative on Council of A. A. A. S.*.....F. M. SETZLER

*Committee of Auditors*.....J. H. MARTIN (chairman), N. F. BRAATEN, W. J. YODEN

*Committee of Tellers*...W. G. BROMBACHER (chairman), A. R. MERZ, LOUISE M. RUSSELL

\* Appointed by Board to fill vacancy.

## CONTENTS

	Page
ETHNOLOGY.—Was the California condor known to the Blackfoot Indians? CLAUDE E. SCHAEFFER.....	181
PALEONTOLOGY.—New Desmoinesian crinoids. HARRELL L. STRIMPLE.	191
PALEONTOLOGY.—Brachiopod homonyms. G. ARTHUR COOPER and HELEN M. MUIR-WOOD.....	195
PALEONTOLOGY.—Substitution for the preoccupied name <i>Hystericina</i> . MERRILL A. STAINBROOK.....	196
BOTANY.—A contribution to the lichen flora of Alaska. GEORGE A. LLANO.....	196
BOTANY.—New or critical Euphorbiaceae from eastern Asia. HSÜAN KENG.....	200
ZOOLOGY.—New distributional records for two athecate hydroids, <i>Cordylo-</i> <i>phora lacustris</i> and <i>Candelabrum</i> sp., from the west coast of North America, with revisions of their nomenclature. CADET HAND and G. F. GWILLIAM.....	206
ZOOLOGY.—The diplopod family Campodesmidae (Polydesmida). RICH- ARD L. HOFFMAN.....	209

20113  
W23  
Vol. 41

JULY 1951

No. 7



# JOURNAL

OF THE

# WASHINGTON ACADEMY OF SCIENCES

## BOARD OF EDITORS

CHARLES DRECHSLER  
PLANT INDUSTRY STATION  
BELTSVILLE, MD.

WILLIAM F. FOSHAG  
U. S. NATIONAL MUSEUM

J. P. E. MORRISON  
U. S. NATIONAL MUSEUM

## ASSOCIATE EDITORS

J. C. EWERS  
ANTHROPOLOGY

C. W. SABROSKY  
ENTOMOLOGY

F. A. CHACE, JR.  
BIOLOGY

J. I. HOFFMAN  
CHEMISTRY

T. P. THAYER  
GEOLOGY

MIRIAM L. BOMHARD  
BOTANY

R. K. COOK  
PHYSICS AND MATHEMATICS

PUBLISHED MONTHLY

BY THE

WASHINGTON ACADEMY OF SCIENCES  
MOUNT ROYAL & GUILFORD AVES.  
BALTIMORE, MARYLAND

Entered as second class matter under the Act of August 24, 1912, at Baltimore, Md.  
Acceptance for mailing at a special rate of postage provided for in the Act of February 28, 1925  
Authorized February 17, 1949

## Journal of the Washington Academy of Sciences

This JOURNAL, the official organ of the Washington Academy of Sciences, publishes: (1) Short original papers, written or communicated by members of the Academy; (2) proceedings and programs of meetings of the Academy and affiliated societies; (3) notes of events connected with the scientific life of Washington. The JOURNAL is issued monthly. Volumes correspond to calendar years.

*Manuscripts* may be sent to any member of the Board of Editors. It is urgently requested that contributors consult the latest numbers of the JOURNAL and conform their manuscripts to the usage found there as regards arrangement of title, subheads, synonymies, footnotes, tables, bibliography, legends for illustrations, and other matter. Manuscripts should be typewritten, double-spaced, on good paper. Footnotes should be numbered serially in pencil and submitted on a separate sheet. The editors do not assume responsibility for the ideas expressed by the author, nor can they undertake to correct other than obvious minor errors.

*Illustrations* in excess of the equivalent (in cost) of one full-page halftone are to be paid for by the author.

*Proof*.—In order to facilitate prompt publication one proof will generally be sent to authors in or near Washington. It is urged that manuscript be submitted in final form; the editors will exercise due care in seeing that copy is followed.

*Unusual cost* of foreign, mathematical, and tabular material, as well as alterations made in the proof by the author, may be charged to the author.

*Author's Reprints*.—Reprints will be furnished in accordance with the following schedule of prices (approximate):

Copies	4 pp.	8 pp.	12 pp.	16 pp.	20 pp.	Covers
100	\$3.25	\$6.50	\$ 9.75	\$13.00	\$16.25	\$3.00
200	6.50	13.00	19.50	26.00	32.50	6.00
300	9.75	19.50	29.25	39.00	48.75	9.00
400	13.00	26.00	39.00	52.00	65.00	12.00

*Subscriptions* or requests for the purchase of back numbers or volumes of the JOURNAL or the PROCEEDINGS should be sent to HAROLD A. REHDER, Custodian and Subscription Manager of Publications, U. S. National Museum, Washington 25, D. C.

*Subscription Rates* for the JOURNAL.—Per year..... \$7.50

Price of back numbers and volumes:	Per Vol.	Per Number
Vol. 1 to vol. 10, incl.—not available.*	—	—
Vol. 11 to vol. 15, incl. (21 numbers per vol.)	\$10.00	\$0.70
Vol. 16 to vol. 22, incl. (21 numbers per vol.)	8.00	0.60
Vol. 23 to current vol. (12 numbers per vol.)	7.50	0.90

\* Limited number of complete sets of the JOURNAL (vol. 1 to vol. 40, incl.) available for sale to libraries at \$341.00

MONOGRAPH No. 1, "The Parasitic Cuckoos of Africa," by Herbert Friedmann. \$4.50

PROCEEDINGS, vols. 1-13 (1899-1911) complete..... \$25.00

Single volumes, unbound..... 2.00

Single numbers..... .25

*Missing Numbers* will be replaced without charge provided that claim is made to the Treasurer within 30 days after date of following issue.

*Remittances* should be made payable to "Washington Academy of Sciences" and addressed to the Treasurer, H. S. RAPPELBYE, 6712 Fourth Street, N.W., Washington 12, D.C.

*Exchanges*.—The Academy does not exchange its publications for those of other societies.



# JOURNAL OF THE WASHINGTON ACADEMY OF SCIENCES

VOLUME 41

July 1951

No. 7

PHYSICS.—*Measure for measure: Some problems and paradoxes of precision.*<sup>1</sup> FRANCIS B. SILSBEE, National Bureau of Standards.

Measurements constitute such an essential part of science that I feel no apology is needed for devoting this address to a rather rambling consideration of certain aspects of the measurement process that are sometimes overlooked. Even Standen in his amusing satire *Science is a sacred cow* recognizes the importance of measurement in science by writing, "If the idols of scientists were piled on top of one another in the manner of a totem pole, the topmost one would be a grinning fetish called Measurement." Though my examples will be drawn for the most part from the physical sciences, with which I have had first hand experience, I want to stress that my theme lies not so much in physics as it does in behavioristic psychology. The whole system of concepts, units, dimensions, and standards by which measurements are made is inherently an artificial creation; a tool like the artifacts about which my predecessor, Dr. Roberts, told us a year ago, created by man in his own image (or as it often seems to the student, perhaps in the image of the devil) and hence showing many of man's peculiarities both his weaknesses and his virtues. The phrase "in his own image" applies in a literal sense to units like the foot, the cubit, and the pace. More figuratively we see his sense of humor reflected in the name "barn" recently given to a unit of  $10^{-24}$  sq cm and used to express the effective cross-section of an atomic nucleus which the experimenter tries to hit with atomic "bullets" from his cyclotron. Man's hero-worship is shown by the use of the names of great scientists as names of units such as the ohm,

ampere, henry, poise, stoke. His nationalistic prejudices have not been absent from the discussions which precede the adoption of such nomenclature.

The value of measurement is not limited to the obvious fields of scientific research, engineering development, control of manufacturing process and the commerce of the market place. Each individual needs a certain amount of quantitative knowledge as a basis for the conduct of his daily life, for the appreciation of the world about him, and for the appraisal of his fellow men and their achievements. Many of our present difficulties, I believe, arise from a lack of quantitative realization by many persons, of the labor equivalent of a billion dollars, the energy equivalent of an atomic bomb, the dimensions of the Siberian steppe or of the Atlantic Ocean.

## CLASSIFICATION OF SCALES

One definition of "measurement" is "the establishment of a one-to-one relationship between the quantity or phenomenon being measured and a number." The value of measurement arises because of the very useful properties possessed by numbers such as identity (e.g., 3 is different from 2), order (e.g., 3 follows 2), size (e.g., 3 is larger than 2), obedience to the rules of arithmetic, algebra, and so on. Here I am using "number" in a rather general sense, for while measurements are commonly expressed by the sequence of real numbers, certain kinds of quantity common in electrical engineering require the use of complex numbers, many quantities in physics require vectors and some quantities require tensors. It should never be forgotten that a numerical measurement is of value *only* to the extent that the

<sup>1</sup> Address delivered February 15, 1951, as retiring president of the Washington Academy of

quantity measured also possesses that particular property of numbers which is to be used. Thus if identity is the only property of the quantity concerned, one must not use addition. You have all heard of the sea captain confronted with a sick seaman whose symptoms, according to the instruction book, called for medicine no. 11. Bottle no. 11 unfortunately happened to be empty, so the captain made up a potion by adding a dose from bottle no. 5 to one from bottle no. 6. As an example in the other direction, consider the electrical engineering student when he first discovers that three terminals A, B, C, may be so energized that his voltmeter shows 110 volts between A and B, 110 volts between B and C, and also 110 volts between C and A. He should not be discouraged at this paradox but instead should recognize that his alternating voltages cannot be characterized merely by their magnitude. Account must also be taken of their time-phase relations as well. Hence they require not merely real numbers but the combination of real and imaginary components and therefore he should apply the rules developed by the mathematicians

for such complex quantities, nowadays called "phasors."

Stevens (1) has systematized the classification of scales of measurement as shown in Table 1. The third and fourth column list the mathematical and statistical processes applicable to each type of scale, and it is only at his "ratio scale" that we get what is ordinarily thought of as a true measurement.

The ordinal scales, however, are not to be despised. Some, such as the Moh scale of hardness which runs from 1 for talc to 10 for diamond, and the triboelectric series, which tries to express the relative polarities of the electric charges produced by friction between different substances, are relatively vague and indefinite. Others, such as the number scales of the wire and sheet-metal gages, are quite definite, though usually purely arbitrary. A partial exception is the Brown and Sharpe (or Amer. wire gage) in which the diameter,  $d_n$ , in mils is related to the gage number  $n$  by the rather complicated formula

$$d_n = 5(\sqrt[39]{92})^{(36-n)}$$

TABLE 1.—A CLASSIFICATION OF SCALES OF MEASUREMENT

Measurement is the assignment of numerals to objects or events according to rule. The rules and the resulting kinds of scales are tabulated below. The basic operations needed to create a given scale are all those listed in the second column, down to and including the operation listed opposite the scale. The third column gives the mathematical transformations that leave the scale form invariant. Any numeral,  $x$ , on a scale can be replaced by another numeral  $x'$  where  $x'$  is the function of  $x$  listed in column 3. The fourth column lists, cumulatively downward, some of the statistics that show invariance under the transformations of column 3.

Scale	Basic empirical operations	Mathematical group-structure	Permissible statistics (invariantive)	Typical examples
NOMINAL	Determination of equality	Permutation group $x' = f(x)$ where $f(x)$ means any one-to-one substitution	Number of cases Mode Contingency correlation	"Numbering" of football players Assignment of type or model numbers to classes
ORDINAL	Determination of greater or less	Isotonic group $x' = f(x)$ where $f(x)$ means any increasing monotonic function	Median Percentiles Order correlation (type O)	Hardness of minerals Quality of leather, lumber, wool, etc. Pleasantness of odors
INTERVAL	Determination of equality of intervals or differences	General linear group $x' = ax + b$	Mean Standard deviation Order correlation (type I) Product moment correlation	Temperature (Fahrenheit and Centigrade) Energy Calendar dates "Standard scores" on achievement tests (?)
RATIO	Determination of equality of ratios	Similarity group $x' = ax$	Geometric mean Coefficient of variation Decibel transformations	Length, Weight, Density, Resistance, Etc. Pitch scale (mels) Loudness scale (sones)

Just why our ancestors chose these particular numbers remains a mystery, but the functional relationship is quite definite and often useful. Its persistence in competition with still more handy alternatives such as  $d_n = (10)^{(50-n)/20}$  is a good example of human conservatism.

Another example of what is still primarily an ordinal scale is the geologic time scale. It is true that by tree rings some 2,000 years can be counted absolutely, and by analyses for  $C^{14}$  in organic materials good approximations can be pushed to some 20,000 years. Yet this interval is so short as to be an almost negligible part of the probable  $10^9$  years since archeozoic times. However, the relative order of superposition of the various geological formations constitutes the primary key for unlocking the riddle of the rocks and is fundamental to the whole science of geology.

#### TEMPERATURE SCALES

The history of the various temperature scales illustrates the transition from an ordinal to a ratio scale. To determine whether one body is hotter or cooler than another by a more certain method than merely touching them, the basic criterion is that heat will always tend to flow from the hotter to the colder. This criterion automatically sets up an ordinal scale. To be more quantitative, the early workers chose some particular property (length, volume, or vapor pressure) of some particular thermometric substance (brass, mercury, or alcohol) as a basis for assigning numbers to a succession of thermal states and thus establishing a complete ordinal scale. However, even if two such scales based on different properties or substances are adjusted to coincide at two points; say the freezing and boiling points of water, it does not follow that they will coincide at intermediate points. It is easy to compare the first and the twelfth inches on a foot rule by sliding an auxiliary fixed interval from one end to the other, but there is no corresponding way to compare the temperature interval from  $32^\circ\text{F}$  to  $33^\circ\text{F}$  with the one from  $211^\circ\text{F}$  to  $212^\circ\text{F}$ . Warming a piece of copper wire from  $30.5^\circ\text{F}$  to  $31.5^\circ\text{F}$  causes an increase in its resistance which is almost

exactly equal to the increase caused by warming it from  $31.5^\circ\text{F}$  to  $32.5^\circ\text{F}$ . In contrast, the effects of warming a mass of  $\text{H}_2\text{O}$  through these two temperature intervals are startlingly different. In general, the use of a different thermometric substance, or of a different property of the same substance will lead to a scale which will differ somewhat in the numerical value assigned to any particular thermal state.

However, many properties of many substances show fairly gradual changes of property with temperature, and abrupt changes like the melting of ice occur only at a few temperatures with any one substance. Hence, a scale limited in its definition to ranges in which changes of state of the thermometric substance do not occur can be used in practice as an interval scale. The older Fahrenheit and Centigrade scales, while strictly speaking merely ordinal, are in practice used as interval scales. Until one has a true ratio scale, however, there is no significance in the old question, "How cold is twice as hot as  $10^\circ$  below zero?"

Kelvin recognized a hundred years ago that the dependence of a temperature scale on particular substances could be avoided by basing the scale on Carnot's principle. This principle states that the efficiency of a heat engine operating on a reversible thermodynamic cycle between two heat-reservoirs, depends solely on the temperatures of the reservoirs and does not depend on the size of the engine or the nature of its working fluid. For his first type of thermodynamic scale Kelvin (2) postulated that "a unit of heat in descending from a body A at temperature  $T^\circ$  of this scale, to a body B at the temperature  $(T-1)^\circ$  would give out the same mechanical effect, whatever be the number  $T$ ." By a suitable choice of the amount of "mechanical effect" derived per "unit of heat" (i.e., the efficiency) which is to correspond to  $1^\circ$  on the new scale and by making an arbitrary choice of the thermal state to which the number 0 is assigned, he set up a thermodynamic scale on which the ice point and boiling point were  $0^\circ$  and  $100^\circ$ , respectively. This first Kelvin scale, however, has little similarity to the ordinary Centigrade scale and did not come into general use. Later Kelvin

introduced an alternative postulate, that the efficiency of an ideal reversible Carnot engine is equal to the quotient of the difference in the temperatures of the two reservoirs divided by the temperature of the hotter. Kelvin chose arbitrarily to make the temperature difference between the ice and steam points exactly  $100^\circ$ . Experiments have shown that on this scale the ice point is close to  $273.16^\circ$ . It has been suggested by Giauque (3) that it might be better to make the arbitrary choice that of a value, say  $273.16^\circ$ , for the ice point and in consequence to let the interval between the steam and ice points become subject to experimental determination and no longer be exactly  $100^\circ$ . This change is under serious consideration, but has not yet been adopted. This second Kelvin scale, because of the form of its definition, is truly a ratio scale, and there is real significance in applying the rules of arithmetic and algebra to the numerical values on this scale in thermodynamic analyses. The first Kelvin scale, defined by  $L = 738 \log_{10} T - 1798$ , is an interval scale.

These two thermodynamic scales offer some interesting contrasts as shown by Table 2 in which an assortment of temperatures are listed on four different scales. At high temperatures the first Kelvin scale is more crowded than the usual scales and might be useful in expressing the extreme temperatures developed within an atomic bomb. At the low-temperature end the first Kelvin scale is much more expanded and extends indefinitely toward  $\infty$  at the cold extreme. When displayed along this expanded scale of temperature, it seems perhaps less unnatural to find in this range the many strange and novel properties of matter like superconductivity and superfluidity that recent researches have brought to light.

The principal moral to be drawn from the existence of Kelvin's first temperature scale is the debunking of the concept of an "absolute zero of temperature" as a "point" at a finite distance from the ice point and perhaps attainable by a finite human effort. Instead, there appears the prospect of an unlimited field for research containing space for any number of new phenomena and offering a perennial challenge to science.

While Kelvin's second scale is ideal from a theoretical standpoint, the experimental difficulties in gas thermometry have set limits to the accuracy with which the scale can be realized in laboratory practice. Because of the need for specifying temperatures within much narrower limits, still another scale has been set up on a purely empirical foundation. This "International Temperature Scale", officially promulgated in 1927 and revised in 1948 (4), is intended to represent as closely as possible the Kelvin thermodynamic scale, but is defined in terms of six fixed points (melting and boiling points of specified substances) and by the use of specified formulas and measuring instruments for the interpolation of intermediate temperatures. From the boiling point of oxygen ( $-182.970^\circ\text{C}$ ) to the freezing point of antimony ( $630.5^\circ\text{C}$ ) the interpolating instrument is the platinum resistance thermometer; from the antimony point to the melting point of gold ( $1063.0^\circ\text{C}$ ) a platinum to platinum-rhodium thermocouple is used; and above the gold point the Planck radiation law.

The 1927 wording of this scale led to the

TABLE 2.—TEMPERATURE SCALES

Fahrenheit °F	Centigrade °C	Kelvin (second) °K	Kelvin (first) °L	
+ $\infty$	+ $\infty$	+ $\infty$	+ $\infty$	
+ $5 \times 10^4$	+ $3 \times 10^4$	$3 \times 10^4$	+3,000	atomic bomb
+10,337	+5,727	6,000	+ 992	sun's surface
+ 6,098	+3,370	3,643	+ 830	M.P. of tungsten
+ 2,774	+1,535	1,808	+ 606	M.P. of iron
+ 212	+ 100	373.16	+ 100	steam point
+ 32	0	273.16	0	ice point
- 371.31	- 182.97	90.19	- 355	oxygen point
- 452.11	- 268.94	4.22	-1,336	helium B.P.
- 455.62	- 270.89	2.2	-1,545	helium lambda point
- 459.58	- 273.09	0.007	-3,370	adiabat. demag.
- 459.69	- 273.16	0	- $\infty$	

amusing paradox that for 21 years it was officially impossible to measure the freezing point of aluminum on the International Temperature Scale (5). When measured with a standard resistance thermometer the freezing point of aluminum is found to be 660.01°C. Since this is above the limit (660.°C) for which the resistance thermometer was then standard, it is evident that a standard thermocouple should have been used. However, if a thermocouple is used, the freezing point turns out to be 659.87°C which is below the range over which the thermocouple is standard, and therefore neither value can be considered official.

#### LOGARITHMIC SCALES

When a particular quantity is of importance, and therefore has to be measured over a very wide range of values, it is frequently convenient to subject the value  $x$  of the original quantity to the mathematical transformation  $y = \log(x/x_0)$ , where  $x_0$  is a fixed reference level and to use the derived quantity  $y$ , both in graphical representations to save space and in common parlance to save words. This transformation is useful in cases such as the transmission of light through a succession of filters of uniform density but differing thickness or the transmission of electrical signals along a communication circuit. Here the intensity  $x$  of the transmitted effect varies with the thickness of the filter or the distance along the line in an exponential way so that its logarithm  $y$  varies linearly with thickness or distance. The effect of an interposed filter or of inserted electrical apparatus is to reduce  $x$  by a factor and to subtract a corresponding amount from  $y$ . The convenience of combining these effects additively has led by a gradual evolutionary process which is still incomplete to the invention of the decibel, the neper and similar units for logarithmic scales. Until  $x_0$  is fixed such logarithmic or "decibel" scales are themselves interval scales of  $y$  derived from ratio scales of  $x$ . Careless handling of decibels can lead to a minor paradox. By definition a bel in  $y$  corresponds to a change in  $x$  by a factor of 10. A decibel is one-tenth of a bel. Hence, one might conclude that a decibel was a change by one-tenth of 10 or 1, which is no

change at all! More seriously, real confusion does arise because at present the word "decibel" is used with a plurality of meanings. Primarily as a pure number, one decibel is the change in the  $\log_{10}x$  which corresponds to a change by a factor of  $\sqrt[10]{10}$  in  $x$  ( $\sqrt[10]{10} = 1.259\dots$ ). Hence 10 successive steps in  $y$  each of 1 decibel will correspond to a total change in  $y$  of 10 decibels or 1 bel and thus to a factor of 10 in  $x$ . Secondly, it is common practice to state the power level in a communication or sound-measuring circuit as being so many decibels. In this phraseology, the number of decibels really expresses logarithmically the ratio of the actual electrical power to some conventionally chosen reference power level,  $x_0$ , often 1 milliwatt, but sometimes by various writers as 6, 10, 12.5 or 1000 milliwatts, and all too frequently not stated at all. Thirdly, the level of sound or noise is usually expressed as a particular number of decibels, when really this number expresses its ratio to some unstated basic reference sound level. The reference level is now pretty definitely standardized at that produced by a sound pressure of 0.0002 dyne per square centimeter at 1,000 cycles per second. It is this somewhat perverted use of "decibel" as a unit of sound level which is most commonly found in the lay press.

Another reason why logarithmic scales have been found convenient lies in the properties of the human senses (at least those of sight and hearing). Weber found experimentally that the least discernible increment  $\Delta x$  in stimulus is approximately proportional to the value  $x$  of the stimulus already present. Thus  $\frac{\Delta x}{x} = k$ . Fechner then introduced the postulate that all "least discernible increments"  $\Delta x$  in stimulus  $x$  corresponded to equal steps  $\Delta y$  in a scale of sensation,  $y$ . The combination of these relations gives

$$\Delta y = K \frac{\Delta x}{x}$$

which by integration leads to  $y = K \log x + C$ . Thus the decibel scale based on the purely physical stimulus turns out to offer possibilities as a scale for measuring the purely psychological quantity "sensation".

However, Fechner's postulate of forming a sensation scale by adding least perceptible increments is not the only possibility and workers in psychophysics are actively trying out experimental procedures by which sensation scales can be built up on the basis of judging equal ratios of sensations or by judging equality of fairly large increments in sensation. Unfortunately these scales do not always coincide with that based on Fechner's hypothesis and the science of psychophysics has a long way to go before it can become truly quantitative.

#### COLOR

Even more complicated to measure than quantities representable by vectors or tensors are complex quantities having a plurality of attributes that are different in nature. A good example is the color of an illuminated surface. Here long experimentation has shown that in any case three independent attributes are involved. In different schemes for the measurement of color, these may be chosen in different ways. In the psychological color solid all possible colors are considered as occupying points in a 3-dimensional continuum. Along one axis the attribute of lightness varies continuously from black at the bottom, through progressively lighter grays to white at the top. Around this "gray axis" the hues of the spectrum can be arranged in order with a sequence of purples bridging across from the violet to the red. For any lightness and hue there is a third radial graduation in saturation from maximally saturated colors at the extremity through less and less saturated colors to gray at the axis. The three cylindrical coordinates of a point in this solid thus can serve to measure a color.

An alternative system is shown in Fig. 1, which shows the ICI chromaticity diagram for color notation and measurement. Here the three independent variables may, very roughly, be described as measures of "redness" plotted as the abscissa,  $x$ ; "greenness" plotted as ordinate,  $y$ ; and "brightness", which is to be thought of as plotted perpendicular to the  $x$ - $y$  plane and as not affecting the chromaticity. In Fig. 1 the curved outer boundary represents the locus of spectrum colors and the straight chord

represents the purples obtainable by superposition in various proportions of violet and red. The diagram shown has the useful property that the color obtained by superposing any two other colors lies on the straight line which joins the two component colors. Other diagrams can be derived by linear transformations from the one shown and have other useful properties.

The paradoxical feature of this diagram lies in the fact that the standard of redness or of greenness, i.e., the points  $x = 1, y = 0$  or  $x = 0, y = 1$  lie outside the spectrum locus so that each of these convenient and regularly used standards for color measurements is quite literally a "light that never was on sea or land."

#### QUADERGY

Man is a very imaginative animal and often conjures up whimsical notions that have only the most tenuous contact with reality. Yet, if such a notion fits into the pattern of his thought habits, he may wish to measure quantitatively such an entirely imaginary concept. An example of this is found in the transmission of electrical energy in an alternating-current circuit. The transmission of energy proper results from the cooperation of simultaneous alternations of the current and of the voltage in step with one another. The resultant transfer of energy is very real, for it is the thing which nowadays in a very literal sense "makes the world go 'round." The annual bill for it in the U. S. A. is some \$4-billion. However, superposed on this phenomenon, there is, except in very special cases, an additional effect often described as the presence of a spurious component of current which is pulsating 90° out of step with the pulsations of the voltage. A physicist describes this situation in realistic terms by stating that under these circumstances an additional definite fixed amount of energy is oscillating back and forth along the transmission line so as to provide the necessary energy to magnetize the motors during those times in the cycle when they need to be magnetized and going back to be restored to the generator for the intervals when the motors do not need it. The actual amount of energy involved is small, being usually of the order

of that delivered by the main energy flow in 1/240 second.

The electrical engineer, or, more specifically, the load dispatcher of a power company, looks at the matter from a very different point of view. He knows that the presence of even a small oscillating component of energy produces additional heating

in his equipment, leads to far greater drops in voltage between his generators and the customers' lamps than does an equal amount of in-phase current, and requires either the installation of expensive capacitor banks or costly modifications in the design of his generators. He feels, quite justly, that the customer whose load is such as to require

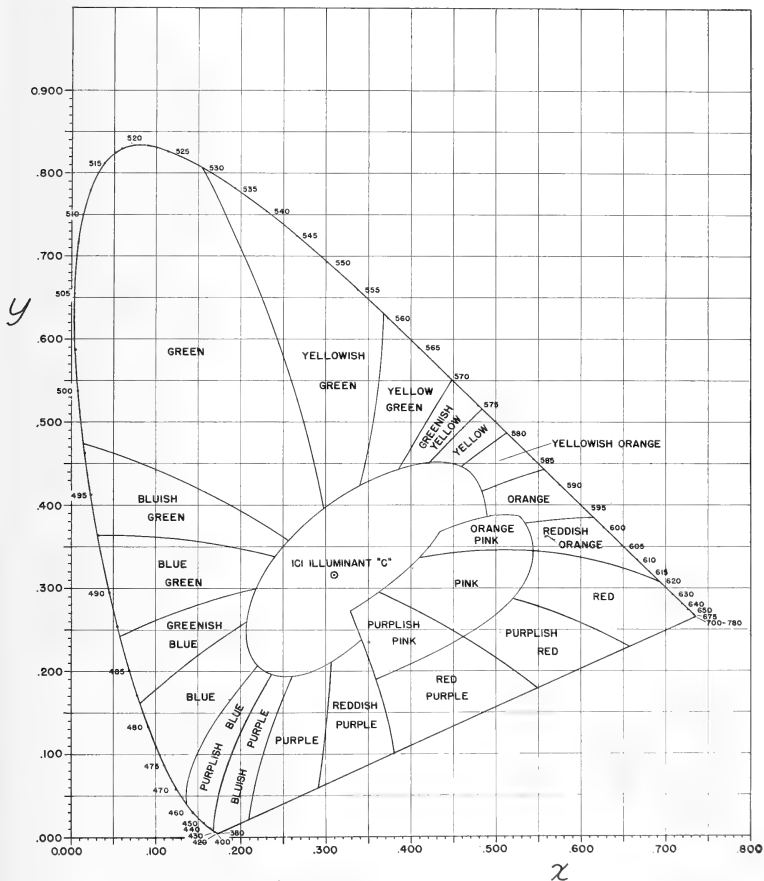

FIG. 1.—Color-mixture diagram according to the 1931 I.C.I. standard observer and coordinate system.

much of this magnetizing service should pay in proportion both to the activity of the oscillating energy required and to the time during which the service is maintained. Accordingly, he just invents a name for the product of the out-of-phase component of the current multiplied by the voltage. Many years ago in the days of the "horseless carriage" and of "wireless telegraphy" this mathematical product was called "wattless watts." But this barbarism proved too crude even for the engineers, and the more dignified term "reactive power" has come into use to distinguish it from the "active power" which measures the true average rate of flow of energy. The unit of reactive power has been christened the "var." Varmeters, which indicate the average value of reactive power, and varhourmeters, which integrate the reactive power with respect to time over the billing period and which are accurate to a few tenths of 1 percent, are on the market. Yet the quantity measured by a varhourmeter is a purely mental creation which is imagined to flow steadily from the supply circuit into an induction motor to keep it on the average properly magnetized and which the operator likes to think of as being "generated" by a static capacitor or an over-excited synchronous generator. In fact, it was only a year or two ago that they got around to christening this imaginary quantity "quadergy" and thus gave a name, if not a local habitation, to this "airy nothing" which they had been measuring with high accuracy for many years.

#### SYSTEMS OF UNITS

*Ideal systems.*—So far we have considered units and scales for the measurement of only single (simple or complex) quantities. A collection of separate unrelated units, like those of the English "system," can, of course, be used to measure a variety of different quantities. Such primitive groups of units tend to "grow up like Topsy" in each new art or industry, as witness: the denier (a size of thread such that 450 meters weigh 0.05 gram) in textiles; the printers' em; the hogshead, the turnip bushel which ranges from 42 pounds in Missouri to 50 in Tennessee and to 60 in

Kentucky; a prize example of an incoherent unit actually used in certain government reports for the effectiveness of an aircraft radiator is "the Btu dissipated per minute, per inch of radiator thickness, per square foot of frontal area, per mile per hour air speed, per degree centigrade temperature difference." The use of a set of such unrelated units requires the memorizing of a large number of numerical conversion factors. How many cubic inches in a quart? How many square yards in an acre?

In contrast to such accidental growths, the ideal would be a single system of units applicable to all branches of science, in which the magnitude of each unit was deducible by an obvious and simple relation from the units of simpler and more fundamental quantities. The metric system which sprang full-fledged from the brains of a group of French savants constitutes the outstanding example of such a coherent system of units. Here not only are the various denominations of units on any one scale related by simple decimal factors, but the units for more complex quantities are related to the more fundamental quantities by simple defining equations.

The difficulty in achieving an ideal and universal system of units in science arises not because such coherent systems are hard to construct, but because they are too easy. As a result the world is now suffering from a surfeit of alternative systems of units. The few fundamental units chosen at the start by one author may differ in size from those chosen by another (as between the centimeter-gram-second systems and the meter-kilogram-second systems). Moreover, an equation which to one person seems to be simple, convenient and the obvious one to use, may seem to another much less simple and convenient than does some different alternative equation.

*Choices as to number of fundamentals.*—Even the number of "fundamental" quantities chosen initially on which to build the rest of the structure is the result of a more or less arbitrary choice. In the field of electromagnetism, systems based on using 3, 4, and 5 fundamental quantities have been proposed, and many gallons of printers' ink have been wasted in arguments on which is "correct."



As a simpler example of the possibility of such alternative systems consider the unit of mass in the metric system. The gram is now defined independently and precisely as one-thousandth the mass of a particular lump of Pt-Ir alloy. The unit of force, the dyne, is then derived as a force of such magnitude that it gives to one gram an acceleration of one centimeter per second per second. Using this system of units, it is then found by the famous Cavendish experiment that two spherical masses  $M$  and  $M'$  placed a distance  $r$  center to center, will exert a gravitational force  $F$  on each other given by

$$F = G M M' / r^2 \quad (1)$$

Here  $G$  is an experimental constant which has been found to have the value  $6.6 \cdot 10^{-8}$  cm<sup>3</sup>/gm sec<sup>2</sup>.

This procedure seems simple and convenient to a physicist, but consider it from the point of view of an imaginary astronomer. Why drag in a particular hunk of a particular alloy? Why not set up a really simple system with only two fundamentals—length and time? Why not simplify equation (1) by setting  $G = 1$  and define unit mass as such a quantity of matter that when placed one centimeter from an equal mass and then released the gravitational attraction will cause a relative acceleration of one centimeter per second per second? The unit of mass in this system is equal to  $1.5 \cdot 10^7$  grams. From a purely logical standpoint, a system based on two fundamental units defined in this way is certainly simpler than the one in current use.

This kind of process can be extended further, and by using additional constants of nature such for instance as the velocity of light and the electronic charge in the same sort of way as  $G$  was used, a system can be set up in which none of the fundamental units is arbitrary or conventional. As we shall see later, the systems of units used in electromagnetism are based on processes of just this type using equations analogous to equation (1), in which numerical values, sometimes unity and sometimes other values, such for instance as  $10^7/4\pi$ , are arbitrarily assigned to the coefficient in the force equation.

*Choices of defining equations.*—An example of how diversity can result from differences in the choice of defining equations when setting up a consistent, coherent system of units from a few chosen as fundamental, can be seen by considering the simple step from length to area. At first sight it seems very obvious that if the unit of length is the inch, the unit of area *must* be the square inch. This, however, does not necessarily follow. Euclidean geometry tells us merely that for geometrically similar figures the areas are proportional to the squares of the linear dimensions; that is,

$$A = kl^2 \quad (2)$$

We are, however, entirely free to fix the size of the unit of area, and thus the value of  $A$  for a given  $l$  by arbitrarily choosing some value for  $k$ . If we regard a square as the obvious "simplest" shape for a unit area and set  $k = 1$  for this shape, we can deduce that the area  $A_r$  of a rectangle of sides  $a$  and  $b$  is  $A_r = ab$  square inches and that the area  $A_c$  of a circle of diameter 1 is  $A_c = \frac{\pi}{4} l^2$  square inches. This, however, is not the only "simple" procedure. The ancients certainly considered the circle as the simplest and most magically significant shape. Why should we not choose to write for the area of a circle of diameter  $l$

$$A_c = l^2 \quad (3)$$

In these units, the area of a rectangle becomes  $A_r = \frac{4ab}{\pi}$  circular inches. This is equivalent to choosing  $k = \frac{4}{\pi}$  for a square.

Another possibility is to choose the equilateral triangle as the shape of the unit area for which  $k = 1$ . In these units if  $l$  is the length of one side,  $k = \frac{8}{\sqrt{3}}$  for a square and the area of a rectangle is  $8 ab/\sqrt{3}$  triangular inches. Still another possibility might be to choose the hexagon as the unit shape. This would perhaps seem simplest to a honey bee.

This makes  $k = \frac{4}{3\sqrt{3}}$  for a square and the area of a rectangle becomes  $\frac{4ab}{3\sqrt{3}}$  hexagonal

inches. The triangle with three sides is surely "simpler" than the square with four. Both the triangle and the hexagon, like the square can be fitted together to measure an area by the straightforward process of filling it with small tiles, each of unit area and counting the number thereof.

One of these alternatives is not a mere whimsey. In the electric cable industry, the cross-sectional areas of wires are always expressed in terms of the circular inch or the circular mil, these units being defined as the areas of circles having diameters of 1 inch and 0.001 inch, respectively. To a workman in a wire factory the use of square inches seems obviously clumsy and unnatural, nor is he at all concerned by the fact that unit circular tiles can not be fitted together to fill and thus measure an area even if it is circular.

I have stressed the arbitrariness of the choice of the square inch as opposed to the equally possible circular inch, not so much because of the industrial utility of the latter as because of the close analogy of this choice to the question of "rationalization" which has wracked the electrical art with prolonged and sometimes violent discussion for 60 years.

*Eight electrical systems.*—The field of electromagnetism has suffered perhaps more than any other branch of science from a plethora of "simple, coherent, logical" systems of measurement, and I shall try to outline some of the reasons for this unhappy situation.

In the early days the simplest way to define a unit electric charge seemed to be to specify that when placed unit distance away from an equal charge the force of mutual repulsion should be unity.

In other words, it seemed simplest to let  $k_e = 1$  in the Coulomb force equation

$$F = k_e QQ'/r^2 \quad (4)$$

You will see that this process is exactly analogous to that of our imaginary astronomer who set up a derived unit of mass coherent with length and time. Starting from the unit charge thus defined, the whole system of centimeter-gram-second electrostatic units has been built up by a process which welds the electrical units firmly to

those of the older mechanical system, and which requires no introduction of any additional new fourth unit.

It is unfortunately equally easy to write

$$F = k_m mm'/r^2 \quad (5)$$

for two unit magnetic poles  $m$  and  $m'$  and to choose  $k_m = 1$ . This gives (if  $r$  is in centimeters and  $F$  in dynes) the cgs electromagnetic system which is a perfectly good alternative system. Maxwell used both systems in his famous treatise. It can be deduced that if one sticks to either system alone, the relation  $k_e k_m = c^2$  holds. Here  $c$  is the velocity of propagation of an electromagnetic disturbance in empty space. This is experimentally found to be  $c = 3.10^{10}$  cm/sec i.e., the velocity of light. Other authors of theoretical treatises combine these two systems using electrostatic units for electrical quantities and electromagnetic units for magnetic quantities. This hybrid third system is called the "Gaussian System" and its use requires that the parameter  $c$  be inserted explicitly in Maxwell's field equations at the proper places.

Practical electricians, however, found it inconvenient to use units so small that it took 100,000,000 of them to equal the voltage of a voltaic cell and 1,000,000,000 of them to equal the resistance of a wire of reasonable dimensions. Under the wise guidance of Maxwell and his colleagues on a committee of the British Association for the Advancement of Science there was set up a fourth group of units called "practical" in which the units were exact decimal multiples of the corresponding units of the cgs electromagnetic system. The electrical units of this group were given individual names—coulomb, volt, ampere, ohm, henry, farad—thus immortalizing the honored pioneers of electrical science.

The experimental process by which the electrical resistance of a wire standard is determined in terms of length, mass and time is exceedingly difficult and laborious. Hence, it was only natural that our forefathers should set up "as a system of units representing the above and sufficiently near to them" still a fifth system in which the unit of resistance was defined as the resistance of a column of mercury of specified dimensions

at a specified temperature and the unit of current was that which would deposit silver from a solution of silver nitrate at a specified rate. This fifth system was christened the "International System of Electrical Units" and had legal status from 1894 to 1947. As far back as 1908 it was recognized that the "International" units differed by small but significant amounts from the practical multiples of the cgs electromagnetic units. Experimental techniques for evaluating with adequate accuracy the "true" or "absolute" values to assign to standards of resistance or of electromotive force were gradually developed; and effective January 1, 1948, the world shifted its basis back to the units of the absolute practical group. The "International System" has therefore now been a dead issue for three years. "May it rest in peace." (6.)

The six electrical units of the absolute practical group are simply and coherently related to each other and to the mechanical joule and watt, but the powers of 10 by which they are related to the cgs electromagnetic system are arbitrary, so that the system as a whole is not coherent. As a result, an experimenter normally makes his measurements in practical units. Then he applies the proper factors to convert his results to units of the self-consistent cgs electromagnetic system. The insertion of these values in the theoretical equations enables him to predict future phenomena quantitatively. A reversion back to the practical units then shows him what values to expect in his later verification measurements.

By a happy coincidence there is a possibility of avoiding the necessity for these repeated conversions and for memorizing a plurality of numerical conversion factors. This was pointed out at the turn of the century by Giorgi (7). If one takes for the basic mechanical units the meter, the kilogram and the second, and if one assigns arbitrarily to the coefficient  $k_m$  in equation (5) the value  $10^7$  instead of unity, it turns out that the practical absolute electrical units automatically show up as members of the resulting self-consistent system. This sixth system in our list is labelled the "Meter-kilogram-second-ampere" or "Giorgi" sys-

tem. Most writers who use this system prefer to consider it as based on four independent fundamental quantities rather than on the classical three. This is equivalent to considering that the coefficient  $k_m$  is not a pure number but that it has dimensions. In terms of length, mass, time and electric current as fundamental quantities, the dimensions of  $k_m$  turn out to be  $[I^{-2} t^{-2} M^1 L^1]$ . Thus in equation (5) the arbitrary assignment of a numerical value to  $k_m$  fixes the magnitude of the unit of  $m$  and hence of the ampere and other electrical units. On the other hand, the arbitrary choice of an electrical quantity, for instance current, as fundamental, fixes the dimensions of magnetic pole strength and by way of equation (5) fixes the dimensions of  $k_m$ .

The assignment to  $k_m$  of dimensions and a value other than unity has brought forcibly into the limelight a very disgraceful situation which has existed for a long time in the field of magnetic units. The trouble shows up clearly in an equation, which can be found in almost any textbook more than fifteen years old, and which relates the magnetic induction,  $B$ , to the resultant magnetizing force,  $H$ , and the intensity of magnetization,  $J$ , at any point in a bar of iron,

$$B = H + 4\pi J \quad (6)$$

This equation may profitably be considered the definition of  $J$ . If  $k_m$  is dimensionless,  $B$ ,  $H$ , and  $J$  all have the same dimensions, whether or not they are quantities of the same physical nature, and, if the magnitude of  $k_m$  is unity, then numerical values are correctly indicated by equation (6) as written. However, if  $k_m$  has dimensions and is equal to  $10^7$  we must write either

$$B = 10^{-7} H + 4\pi J \quad (7)$$

or 
$$B = 10^{-7} (H + 4\pi J) \quad (8)$$

According to the former "intensity of magnetization" is defined as a quantity having the same dimensions as magnetic induction. According to the latter "intensity of magnetization" has the same dimensions as magnetizing force. There is nothing in the equations of the earlier literature which used  $k_m = 1$  to indicate which concept the

writer preferred. In recent textbooks some authors use one and some the other meaning for the words "intensity of magnetization," while still others dodge the issue. The same ambiguity exists in the related concepts of magnetic moment and magnetic pole strength. Because of the differences in current usage, national and international standardizing bodies hesitate to decide the issue and in the meantime the volume of ambiguous and conflicting literature grows apace!

Still another question regarding electrical units which had been left unanswered for some 60 years is "to rationalize or not to rationalize". The word "rationalize" is here used with a highly specialized meaning which perhaps can be best understood by an analogy with the case of the circular inch as a unit of area. In passing from length to area by choosing  $k = 1$  in equation (2) for the case of a circular shaped unit area the simple equation (3) resulted for circular areas in general, and as a consequence of this, the factor  $\pi$  appeared in the formulas which involved rectangular shapes.

Similarly the electric or magnetic field around a point charge or pole has a spherical symmetry. Hence, the setting of  $k_e = 1$  in equation (4) or of  $k_m = 1$  in equation (5) which relates to point charges and poles insures that  $\pi$  will not appear in the resulting equations for arrangements having spherical or circular symmetry such as those for the capacitance of a sphere of radius  $r$ ,

$$c = \epsilon r \quad (9)$$

or for the magnetizing force at a radius  $r$  from a long straight cylindrical conductor carrying a current  $I$

$$H = 2I/r \quad (10)$$

On the other hand, the factor  $\pi$  appears instead in many other formulas where it would not be expected, as in that for the capacitance between rectangular plates of area  $A$  and separation  $t$

$$c = \frac{\epsilon A}{4\pi t} \quad (11)$$

or for the magnetizing force inside a long

solenoid of square cross section wound with  $n$  turns per unit length

$$H = 4\pi nI \quad (12)$$

Heaviside pointed out that "the unnatural suppression of the  $4\pi$  in the formulas of central force, where it has a right to be, drives it into the blood, there to multiply itself, and afterward break out all over the body of electromagnetic theory." As a "radical cure for this eruption of  $4\pi$ 's" he urged a shift to what he labelled a more "rational" set of units, and himself consistently used a "rationalized" system in which  $k_m$  was set equal to  $1/4\pi$ . This system of units, the seventh in our list, has been used in a number of theoretical treatises and is usually designated the "Heaviside-Lorentz" system. Its units differ by various powers of the incommensurable factor  $\sqrt{4\pi}$  from those of the absolute practical system and for this reason have never come into general use.

A related procedure applicable to the MKSA system and sometimes referred to as "sub-rationalization" or "total rationalization" involves writing equation (5) in the form

$$F = \frac{1}{4\pi} \left( \frac{10^7}{4\pi} \right) \frac{mm'}{r^2} \quad (13)$$

where the quantity in the parentheses is the reciprocal of what is usually called the "permeability of space." The resulting system of units, the eighth on our list, is designated the "rationalized MKSA" or the "rationalized Giorgi" system. The International Electrotechnical Commission, which in 1935 had voted its approval of the Giorgi system, took the further step in July 1950 of adopting this form of rationalization.

Recent developments in the radio field have brought the practical engineer and laboratory worker into much closer contact with the theorist and pedagogue than ever before, to the great benefit of both. The rationalized MKSA system offers advantages to both, which I believe will suffice to bring it into very general use in the electrical field in the not very distant future. It can

easily be extended to cover all branches of physical science. A name, "newton," has been assigned to its unit of mechanical force, but I have seen no indication that it is displacing the entrenched cgs units in theoretical mechanics or those of the mechanical engineers' units based on the kilogram force.

#### CLASSIFICATION OF STANDARDS

The various ways that have been or are currently in use for defining units of measurement fall naturally into a number of classes. In early work, individual or personal standards were used such as Galileo's pulse, with which he timed the pendulous swings of the chandelier in the cathedral of Pisa; Fahrenheit's body temperature, which fixed the 100° point on his original temperature scale; the pieces of iron and brass wire used by Ohm; the foot; the pace; and, all too often even in current publications, a millimeter deflection of an undefined galvanometer of unspecified sensitivity. Following these, came particular artifacts such as bronze cubits, intended to embody the length of the king's arm, and perhaps some dimensions incorporated in the Egyptian pyramids. The supreme examples of such artifacts are the standard prototype meter and kilogram, which now repose in the vaults at the International Bureau of Weights and Measures.

To secure reproducibility, however, definitions based on natural objects have frequently been used. Examples of such are the barley-corn, and at the other extreme, the earth-quadrant, which was originally used in the definition of the meter, and our present time standard, the rotation of the earth. In a slightly different category are definitions based on the physical or chemical properties of specific substances. In this class were the definition of the International Ohm as the resistance of a specified column of mercury and that of the International Ampere as the electric current which would produce electrochemical action at a specified rate. The fixing of the kilogram by the density of water and the setting up of a thermometric scale by the relative thermal expansion of mercury and glass and by the use of standard melting and boiling points

are other examples. The old definition of the curie as the unit of radioactivity also comes in this category, because it was the activity of a specified amount (1 gram) of a specified aggregation of substances.

A still different category is the use of the properties of individual atoms as distinct from the properties of matter in bulk. Thus, the new curie and the rutherford, defined as the activity corresponding to  $3.700 \times 10^{10}$  and  $10^6$  atomic disintegrations per second respectively are philosophically distinct from the old curie. In this atomic class are the use of the wave lengths of cadmium radiation or more recently of that from the mercury 198 isotope as standards of length, and the frequency of oscillation of the ammonia molecule in the "atomic clock" (8).

#### EVOLUTION OF UNITS

In all fields there have been in progress evolutionary shifts in the choice of units. The parallel developments of the electrical units and that of the temperature scale illustrate this. In both fields, the early workers used measuring schemes based on properties of matter such as thermal expansion of mercury in glass on the one hand, and the electromotive force of particular voltaic cells on the other. Theoretical relations were then worked out and resulted in the Kelvin thermodynamic temperature scale and the cgs electromagnetic and electrostatic unit systems of Maxwell. In each field, however, the need for higher precision than could be obtained in the experimental realization of the theoretical units forced the introduction of an auxiliary system based again on the properties of matter in bulk. These auxiliary systems, the "International" electrical units and the "International Temperature Scale" formed the basis for all precise scientific measurements as well as for commercial operations, although the theoretical unit systems continued to be recognized in parallel with them as being of an even higher echelon. The electrical art has finally reached a level where the theoretical system can be realized experimentally with an accuracy at least comparable with that attainable with the auxiliary system and has therefore sloughed off the latter. The temperature scale has not yet reached this

enviable position, but perhaps will do so in the not too distant future.

The evolution of the units of length and mass have followed a somewhat different pattern. At the introduction of the metric system, the earlier arbitrary units embodied in artifacts were displaced by the units based theoretically on the earth-quadrant and the density of water. As in the other fields, the demand for ever increased accuracy forced the abandonment of the theoretical values for an auxiliary system which in this case consisted of two simple artifacts, the prototype standard meter bar and the prototype kilogram mass. There is now pending a shift of the unit of length to an atomic basis, the wave length of radiation from Hg<sup>198</sup>, but it will probably be a long time before techniques for counting individual atoms can be developed to their logical climax of enabling the mass of the proton to be used as a practical standard.

The measurement of time has shown a still different history. The habits of mankind are so closely geared to the astronomical periodicities that from earliest antiquity the unit of time has been based on the rotation of the earth. The recent development of "atomic" clocks, the unit of which is based on some natural molecular frequency, such as that of ammonia, offers the first significant departure from this basis. However,

it seems safe to predict that no matter how rapid and successful the evolution of a laboratory time system based on atomic units may be, and no matter what vagaries it may show to exist in the motion of the earth, there will always be, in common use, an astronomical time system based on the mean solar day.

I hope that I have shown that the process of measurement is, after all, a very human activity; that in it may be found illustrations of the foibles as well as the wisdom of *Homo sapiens*; that units are unfortunately not fixed, immutable creations of nature, but merely human constructs; that there is a real progression in the evolution of systems of measurement; and that their present imperfections should be a challenge to the scientists of the future.

#### REFERENCES

- (1) STEVENS, S. S. *Science* **103**: 677. 1946.
- (2) THOMSON, W. *Phil. Mag.* **33**: 313. 1848.
- (3) GIAUQUE, W. F. *Nature* **143**: 623. 1939.
- (4) STIMSON, H. F. *Journ. Res. Nat. Bur. Standards* **42**: 209. 1949.
- (5) WENSEL, H. T. *Journ. Res. Nat. Bur. Standards* **22**: 376. 1939.
- (6) SILSBEE, F. B. *Nat. Bur. Standards Circ.* **475**. 1949.
- (7) GIORGI, G. *Trans. Int. Elec. Congr. St. Louis* **1**: 136. 1904.
- (8) HUNTOON, R. D., and FANO, U. *Nature* **166**: 167. 1950.

MATHEMATICS.—*A problem in geometric probability.* JEROME CORNFIELD and HAROLD W. CHALKLEY, National Cancer Institute. (Communicated by Richard K. Cook.)

#### 1. INTRODUCTION

We have recently published a description of a method for estimating volume-surface ratios for closed 3-dimensional figures of arbitrary shapes (1). The method involves throwing a line of fixed length,  $r$ , at random in a space containing the figure. We count the number of times either of the two end points fall in the interior of the figure, and denote it by  $h$  for hits, and the number of times the line intersects the surface of the figure and denote it by  $c$  for cuts. The method depends upon the fact that

$$(1.1) \quad r \frac{E(h)}{E(c)} = 4 \frac{V}{S}.$$

where  $V$  is volume and  $S$  is surface and  $E$  stands for expected value.

We note that (1.1) holds for reentrant as well as nonreentrant figures and is consequently more general than the nonparametric relationships of this type, such as Crofton's (2), that have been previously established. This note is devoted to a proof of (1.1).

#### 2. A DEFINITION OF A RANDOMLY THROWN LINE

In what follows we assume that in throwing a line of length  $r$  at random (a) there is a uniform probability that one end point,  $P$ , will take on any position in the space and

(b) there is a uniform probability that the other end point,  $P^1$ , will take any position on the surface of a sphere with center at  $P$  and radius  $r$ . This is an obvious generalization of the assumptions usually made in problems of geometric probability in two dimensions, e.g., in Buffon's needle problem. We have presented evidence elsewhere (1) which indicates that this appears to provide a satisfactory description of the physical process of throwing a line at random.

3. THE EXPECTED VALUE OF THE NUMBER OF HITS

We shall show

$$(3.1) \quad E(h) = \frac{2Vn}{X},$$

where  $X$  is the volume of the space in which the line segment falls and  $n$  is the number of throws. Because there are difficulties in visualizing the necessary three dimensional figure, we shall begin with the two dimensional problem.

We start with a closed figure,  $F$ , of area  $A$  in a square of side  $X^{1/2}-2r$  (Fig. 1). The end point of the line segment,  $P$ , will occupy with uniform probability all positions in the square of side  $X^{1/2}$ . Since the angle that the line segment makes with the  $X$  axis,  $\theta$ , varies from 0 to  $\pi$ , the point,  $P^1$ , will occupy all but some corner positions in the square of side  $X^{1/2} + 2r$ .

If we consider fixed values of  $y$  and  $\theta$ , the probability that the point  $P$  will fall inside the figure is  $f(y)/X^{1/2}$ , where  $f(y)$  is the width of the figure at ordinate  $y$ . (For values of  $y$  falling outside the figure  $f(y) = 0$ .) Similarly, the probability that for fixed values of  $y$  and  $\theta$  the point  $P^1$  will fall inside the figure is  $f(y, \theta)/X^{1/2}$ . If we now let  $y$  vary from 0 to  $X^{1/2}$ , but hold  $\theta$  fixed, we have

$$(3.2) \quad \begin{aligned} \text{Prob. } (P \in F) &= \frac{1}{X} \int_0^{X^{1/2}} f(y) dy \\ \text{Prob. } (P^1 \in F) &= \frac{1}{X} \int_0^{X^{1/2}} f(y, \theta) dy. \end{aligned}$$

Each integral, obviously, is an expression for the area of the figure,  $A$ , and is consequently independent of  $\theta$ . In  $n$  throws, therefore, the expected number of hits by

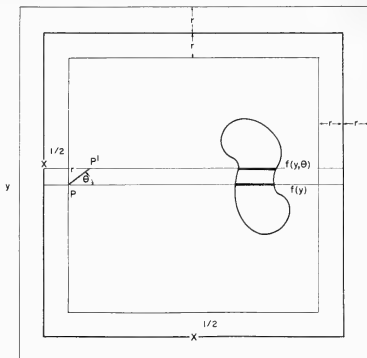

FIG. 1

either the point  $P$  or the point  $P^1$  is  $An/X$ . Since the expected value of a sum is the sum of the expected values, the expected number of hits counting both end points is  $2An/X$ .

The proof for three dimensions is identical except that for the point  $P$  we must consider the probability that it is included in  $F$  for fixed values of  $z$ , the additional dimension, as well as  $y$ . Similarly for the point  $P^1$  we must consider the probability that it is included in  $F$  for fixed values of  $\phi$ , the angle with the  $z$  axis, as well as  $\theta$ . We then have

$$(3.3) \quad \begin{aligned} \text{Prob. } (P \in F) &= \frac{1}{X} \int_0^{X^{1/2}} \int_0^{X^{1/2}} f(z, y) dy dz \\ \text{Prob. } (P^1 \in F) &= \frac{1}{X} \int_0^{X^{1/2}} \int_0^{X^{1/2}} f(z, y, \phi, \theta) dy dz \end{aligned}$$

where each integral is an expression for the volume of the figure,  $V$ , and is consequently independent of  $\phi$  and  $\theta$ . In that case the expected number of hits in  $n$  throws by either the point  $P$  or  $P^1$  is  $Vn/X$ , while the expected number of hits by both is  $2Vn/X$ .

4. THE EXPECTED VALUE OF THE NUMBER OF CUTS

We may without loss of essential generality consider the surface of  $F$  as composed of  $m$  quadrilaterals of area  $S_1, S_2 \dots S_m$  with

$$(4.1) \quad S = \sum_{i=1}^m S_i.$$

If we denote the number of cuts on the  $i^{\text{th}}$  quadrilateral by  $c_i$ , we have

$$(4.2) \quad \begin{aligned} c &= \sum c_i \\ E(c) &= \sum E(c_i) \end{aligned}$$

Furthermore, since a straight line and a quadrilateral can intersect at only one point,  $E(c_i)$  is equal to the probability of intersection times the number of throws.

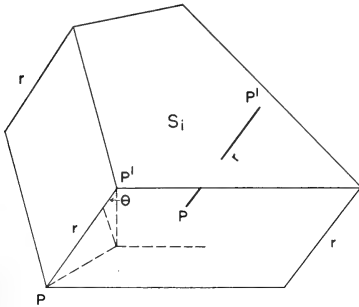

FIG. 2

If we consider the  $i^{\text{th}}$  quadrilateral, with surface area,  $S_i$ , the probability that a random line of length  $r$  will intersect it is the probability that the end point  $P$  will fall inside the parallelepiped with volume  $S_i r \cos \theta$  (Fig. 2). From the preceding section this probability is

$$(4.3) \quad \frac{1}{X} S_i r \cos \theta$$

for a fixed value of  $\theta$  and

$$\frac{1}{X} S_i r \int_0^{\pi/2} f(\theta) \cos \theta d\theta$$

for  $\theta$  varying from 0 to  $\frac{\pi}{2}$  according to the density function  $f(\theta) d\theta$ . We show in the next section that the assumptions of section 2 imply

$$(4.4) \quad f(\theta) d\theta = -\sin \theta d\theta.$$

This is the probability that a random line will form the angle  $\theta$  with any other fixed line in the space. In that case

Prob. ( $P \in$  parall.)

$$(4.5) \quad \begin{aligned} &= \frac{1}{X} S_i r \int_0^{\pi/2} \cos \theta \sin \theta d\theta \\ &= \frac{1}{2X} r S_i \end{aligned}$$

and

$$(4.6) \quad \begin{aligned} E(c) &= \frac{rn}{2X} \sum S_i \\ &= \frac{rnS}{2X}. \end{aligned}$$

Combining (4.6) and (3.1) we obtain (1.1).

### 5. THE PROBABILITY DISTRIBUTION OF $\theta$

We wish the probability that a random line, defined as in 2, will form angle  $\theta$  with a fixed line. We may take this fixed line as a radius of the sphere with center at  $P$  and radius  $r$  (Fig. 3). The probability that the line with end points  $P$  and  $P'$  will form an angle  $\theta$  with a radius of the sphere is the probability that the end point  $P'$  will fall in the circumferential belt of area

$$2\pi \sqrt{r^2 - y^2} ds$$

where  $y/r = \cos \theta$ . Hence

$$(5.1) \quad \begin{aligned} \text{Prob. } (P' \in \text{circum. belt}) \\ &= f(\theta) d\theta = \frac{2\pi \sqrt{r^2 - y^2} ds}{2\pi r^2}. \end{aligned}$$

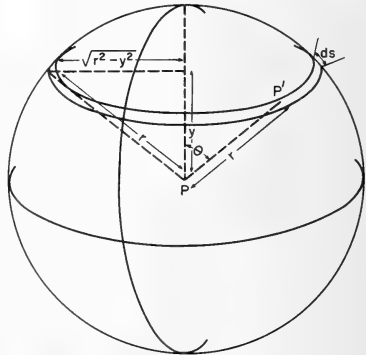

FIG. 3



It is easy to show, however, that

$$(5.2) \quad ds = -\frac{r^2 \sin \theta d\theta}{\sqrt{r^2 - y^2}},$$

so that

$$(5.3) \quad f(\theta) d\theta = -\sin \theta d\theta.$$

When  $y$  varies from 0 to  $r$ ,  $\theta$  varies from

ETHNOLOGY.—*Interesting animal foods, medicines, and omens of the eastern Indians, with comparisons to ancient European practices.*<sup>1</sup> LLOYD G. K. CARR, Hendrix College, Conway, Ark. (Communicated by W. N. Fenton.)

At this time when attention is turned toward emergency foods and medicines, those little-known foods and medicines of the Indian such as insects, turtles, frogs, salamanders, fishing worms, and grubs may be considered. In time of great need one can make a fairly wholesome supplementary meal on these creatures, securing in turn a supply of minerals and possibly vitamins.

Turning to the reptile lore of the North<sup>2</sup> we note that the Montagnais really have so little to do with snakes that the only use to which they are put is as a cure for rheumatism, for which the skin of a snake is necessary. Dr. Speck tells us, "These people of the north do not fear snakes. They sometimes put them inside their shirts and carry them about."

From Speck we get further impressions of reptile lore among these northern Indians. It is found that northern Algonkian herpetology teaches that sympathetic influences are active through things and ideas and names. He says:

Hence in the practice of therapeutics, a snake-skin, according to Penobscot belief, becomes a cure

<sup>1</sup> The author expresses great appreciation for the association he was able to enjoy with the late Dr. Frank G. Speck, professor of anthropology at the University of Pennsylvania, under whose guidance this study was begun, and for a grant received through Hendrix College from the Carnegie Foundation for the Advancement of Teaching, which enabled the author to bring to a conclusion a preliminary report on the ethnological phase of his studies.

<sup>2</sup> SPECK, FRANK G. *Reptile lore of the northern Indians*. Journ. Amer. Folklore 36: 273-280. 1923.

$\frac{\pi}{2}$  to 0. If we permit  $\theta$  to vary in the reverse direction, i.e., 0 to  $\frac{\pi}{2}$ , we may delete the minus sign.

#### REFERENCES

- (1) CHALKLEY, H. W., CORNFIELD, J., AND PARK, H. *A method for estimating volume-surface ratios*. Science 110: 295-297. 1949.
- (2) CROFTON, W. *Probability*. Encycl. Brit., ed. 9.

for rheumatism when bound around the infected part. Such a skin must have been taken from a living snake. The idea is no doubt derived from the feeling in the native mind, that a creature with so pliable a frame is not only free from stiffness himself, but that contact with him can cure stiffness in others. Similarly, a snake-skin, the Malechite say, worn around the head or hatband, will ward off enemies. A snake's tongue taken from a living snake, dried and carried about, will both cure and prevent a toothache. Further south the Mohegan and the Iroquois believe that a toothache can be cured by gently biting the body of a living Green snake.

Josselyn,<sup>3</sup> writing from voyages made in America, 1638 and 1663, speaks of the employment of reptiles and batrachians by the Massachusetts Indians. In speaking of the "tortous" (land turtle) he states, "They are good for the Ptsisick, Consumption and some say the Morbus Gallicus (venereal disease)." Josselyn records that the "Green-turtle is the best for food, and that it is affirmed that the feeding upon this turtle for a twelve-month forbearing all other kinds of food will cure absolutely Consumptions, and the Great Pox (syphilis); They are very delicate food, and their eggs are very wholesome and restorative."

Also "the ashes of a Sea-turtle mixed with oyl or Beargrease causeth hair to grow; the shell of a land-Turtle burnt and the ashes dissolved in wine and oyl healeth sore legs; the flesh burnt and the ashes with wine and oyl healeth sore legs; the ashes of the burnt shell and the whites of eggs comical

<sup>3</sup> JOSSELYN, JOHN. *New Englands rarities discovered*. London, 1672

pounded together healeth chaps in women's nipples and the head pulverized with it prevents the falling of hair, and will heal the Hemorrhoids, first washing of them with white wine, and then strewing on the powder."

With respect to the rattlesnake he orders this usage. "They have Leafs of Fat in their Bellies, which is excellent to anoint frozen Limbs, and for Aches and Bruises wondrous sovereign. Their Hearts, swallowed fresh, is a good Antidote against their Venome, and their Liver (the Gall taken out) bruised and applied to thier Bitings is a present remedy." Also their skins were said to be of value, "Their skins likewise worn as a garter is an excellent remedie against the cramp."

Gladys Tantaquidgeon,<sup>4</sup> in her study of the Delaware formerly of the Pennsylvania area, makes interesting comments with respect to the use of snake oil by the Delaware. "Rattlesnake oil is valuable in treating stiff joints. It is very powerful and should be used sparingly. Only a few drops on the finger tips, and applied to the affected parts. The skin may be bound on the wrists and ankles to strengthen them." Among the Wampanoag of Cape Cod, however it is believed that if the oil is used alone, "it will unjoint you." Likewise, the eastern Cherokee Indians have a snake oil remedy.

In the tradition of the Powhatan Tribes of Virginia some odd animal medicines and foods stand out. Mott Byrd, a Rappahannock Indian in his seventies, told that a snake shell ground up was highly prized as it causes boils to come to a head. Snakes play another important part in the medicines of the Rappahannock Indians. Speck<sup>5</sup> relates that the blacksnake skin wrong side out is worn as a belt around the waist to relieve backache or rheumatism. This is somewhat similar to the Massachusetts Indians use of the rattlesnake skin for cramps.

Turtles have been used by the Indian tribes of Virginia from early times. Gabriel Archer, writing in 1607, speaks of an Indian of the town of Arahatec on the James River below the falls, "He made ready a land turtle

which he ate." Today the Pamunkey use the terrapin and turtle as incidental foods. The terrapins (*Chrysemys* spp.) are dredged in wintertime in mud bottoms of rivers and creeks with net and iron drag in 5-8 feet of water. The shells are cut apart and the flesh is made into soup. If eaten out of season it is said that they will cause eye swelling and a tickling in the throat as they go down. From the time of Josselyn the Virginia Indians have used their Indian word "Terrapin" for the designation of the turtle that occupies rivers, "The Turtle that lives in Lakes and is called in Virginia a Terrapin."

The snapping turtle (*Chelydra serpentina serpentina*) is taken by metal hooks baited with salt eel or catfish, tied to arrowwood (*Viburnum* sp.) stick, the bait being allowed to rest on the bottom. The use of cane stalks is employed by the Chickahominy. They are caught during January and may be cooked, boiled or roasted in their own shells as a "turtle shell dish."

The terrapin (*Terrapene carolina carolina*) called highland skillpot by the Virginia Indians is found in fields, woods or highlands, occasionally also by rivers from April through the fall months. It is rarely eaten, but sometimes it may be roasted; the legs only may be eaten or made into soup. The flesh is said to smell strongly.

Terrapin eggs (various species of *Chrysemys*) are considered a wholesome delicacy among the Pamunkey and are eaten as a part of a meal. Clutches of 10 to 20 eggs are found in sand banks along swamp and river edge, where signs betray recent laying. Hawks, eagles, crows, owls, skunks, and opossums know the time and place to hunt them, and one can often locate the eggs by observing the hunting habits of these creatures. They are gathered from the end of May through the summer months. They are boiled, the tough skin being peeled off.

Salamander eating is not absent in the incidental diet of the Cherokee. It is especially interesting to find that the "spring lizard" (probably *Gyrinophilus danielsi danielsi*), which inhabits the mountain streams, has been eaten by the Indians, as Jesse Lambert informs us. Also the water dog, or "hell-bender" (*Cryptobranchus alleganiensis*), is utilized by the Cherokee for soups and stew.

<sup>4</sup> TANTAQUIDGEON, GLADYS. *A study of Delaware Indian medicine practice and folk beliefs*: 67. Pennsylvania Historical Commission, 1942.

<sup>5</sup> Loc. cit.

Turning to the Nanticoke reptile lore we find the belief that if hogs eat "ground puppies," the large *Ambystoma* salamanders, they will die. This is no doubt true, for toxic principles are present in the skin of the salamanders, as in the toads. Lincoln Harmon told that if one swallows a scorpion, which is the designation of the blue-tailed skink (*Eumeces fasciatus*) and also the fence lizard (*Sceloporus undulatus*) "in going down it will eat your heart, thereby killing you. Also death will ensue if they make a complete circle around your body."

Winona Wright advises that placing a blacksnake on the fence was sure to bring rain. She had observed this to have been true a number of times. Another interesting omen of the Indians, this time of the Massachusetts Indians, concerns the use of the Rattlesnake skin for cramps.

Insects are also an important part of the diet of the Indian. Speaking with Dr. Speck discloses that the Malechite Indians have a knowledge of eating ants. Sapiel Paul, over 60, born at French Village on the St. John River, New Brunswick, relates that his father took him to the woods continually on trapping, hunting, and woodcutting trips. Occasionally, when a dead tree was found swarming with black ants, he would crush some of the ants and give them to him to eat as a medicinally beneficial tidbit in the spring. Gabriel Polchis, another Malechite Indian, also indulged in this delicacy.

In connection with the medicinal properties of ants we learn some striking points. The *London Pharmacopoeia* of 1696 reveals: "Ants are hot and dry; excite lust, and by their sharp scent wonderfully refresh the spirit: the greater, or winged, with a little salt, cure the psora, or scab, and leprosie." Savarof, once addressing the Russian Soldiers, told them to "have a dread of the hospital! German Physic stinks from afar; is good for nothing and rather hurtful; but take care of your health; a soldier is inestimable! Your messmates will know where to find roots, herbs, and pismires (red ants) for your cure." Indeed, the ant is known to contain formic acid, which is used for medicinal purposes.

With respect to the Massachusetts In-

dians,<sup>6</sup> there is an interesting reference to lice-eating. During the time of John Eliot around 1646 a law was passed: "If any shall kill their lice between their teeth, they shall pay five shillings." It is obviously intimated that they were eaten, as they are very sweet and form, therefore, a tasty tidbit.

Among the Montauk Indians of Long Island the oak gall, produced by a wasp cynipid, is known as a food delicacy, the spongy inside fiber usually being eaten under the name "sour jugs." The sour nature of the fiber probably indicates vitamin-C content. Investigations along this line would be worth while.

Known to the Nanticoke Indians is the use of wasp nests, as well as cobwebs. Oscar Wright knows of their making use of the nests of the southern paper wasp (*Polistes annularis*). The papery pulp is allowed to soak in vinegar, in turn being applied to boils. Asbury Thompson relates that spider web will stop bleeding, while Oscar Wright mentions this story: "A man was very lazy and one day was chopping wood. He stuck his ax in the wood and went to sleep. In the meanwhile the ax fell down, cutting his foot badly. It was thought that he was going to bleed to death, but spider web stopped the blood." Among the Delawares of Oklahoma also the spider web is applied to fresh wounds as a styptic.

Both Asbury Thompson and Oscar Wright speak of the employment of the bee sting for rheumatism. Indeed, the use of bee venom for this ailment has attracted much attention by the medical profession, some of whom hold it efficacious.<sup>7</sup> Dr. A. G. Richards writes me in this connection: "Bee venom was held in high repute during the Middle Ages and stressed by homeopaths in the 19th century. You will find it listed with directions for preparation in the 'American Homeopathic Pharmacopoeia' (under the name of 'Apium Virus'). There are persistent claims of use in the treatment of rheumatism both in the popular and medical literature. Also it has been used in skin

<sup>6</sup> DRAKE, SAMUEL G. *The book of Indians*: 113. 1841.

<sup>7</sup> BECK, B. F. *Bee venom, its nature and effects on arthritic and rheumatoid conditions*. New York. 1935.

diseases, inflammation of the bladder and urethra, etc."

From Mott Byrd comes information on the value of the bee sting. He described how as children they used to be friendly with bees. They would "lobolly with them" in the grass. In his early life they would stick five or six bees or wasps under a cloth, making them sting as a cure for stiff joints and rheumatism. He states that the bees "know enemy and clamp down." It would seem as though the bee sang, "Let me go." Mott's reply was, "Put it to us." He remarked that the stiff joints were already hurting so badly that one didn't really feel any pain from the sting. His ideas were that the bee carried away with it some of the poison in the stiff joints, "When the bee went down, the pain went down."

To the Rappahannock the thousandlegs (milliped) has been a worth-while item. It was found to be expert in cleaning out ears.

The 17-year locust (*Tibicen septendecim*) is a choice delicacy among the Cherokee. They dig them when they are just ready to emerge from the ground. For preparation, the legs are removed. Then the locusts are fried in hot fat, according to Jessie Lambert. Mrs. Moses Owl gives a method by which they are preserved. They are so highly prized that during years of abundance they are salted down and pickled for canning. Mrs. McClain knows of another method of preparation by the Cherokee; she states that they often concoct a locust pie from them.

From the extensive periodical on the *Cicada* by Marlatt<sup>8</sup> comes an early reference on the use of locust by the Indians:

That the Cicada was eaten by the red men of America, both before and after the coming of the Colonists, is indicated in a memorandum, dated 1715, left by the Rev. Andreas Sandel, of Philadelphia, who, referring to the use of locusts as food in eastern Asia, states also that the Cicada is so used by the Indians. Dr. Asa Fitch corroborates this statement, giving as his authority Mr. W. S. Robertson, who informs him "that the Indians make the different species of Cicada an article of diet, every year gathering quantities of them and preparing them for the table by roasting in a hot oven, stirring them until they are well browned".

<sup>8</sup> MARLATT, C. L. *The periodical cicada*. U. S. Bur. Ent. Bull. 71: 103-104. 1907.

Marlatt's remarks on its value are fitting here:

Theoretically, the Cicada, collected at the proper time and suitably dressed and served, should be a rather attractive food. The larvae have lived solely on vegetable matter of the cleanest and most wholesome sort, and supposedly, therefore, would be much more palatable and suitable for food than the oyster with its scavenger habit of living in the muddy ooze of river bottoms, or many other animals which are highly prized and which have not half so clean a record as the periodical Cicada.

Among the insect clan, young wasps and yellow-jackets are eaten. These are found to be very sweet and luscious and should satisfy anyone's hunger for sweet, as they are readily available. When rambling around old barns in the country, one is certain to find wasp and yellow-jacket nests filled with the sweet white grubs, comprising a feast that is not forgotten. Hear what Vincent Holt<sup>9</sup> has to say about them in his admirable little book: "From bees, we derive a delicious sweet in the form of golden honey; from wasps we may, if we choose, derive an equally delicious savoury. What disciple of Old Izaak Walton, when he has been all the morning enticing the wily trout with luscious grubs baked to a turn has not suspected a new and appetising taste imparted to his mid-day of bread and cheese or a sandwich?" Again the Indian is far ahead of modern civilization in his knowledge and exploration of the value not only of insects, but also the other living things that comprise the organic environment. Close contact with it and keen observation has made the Indian the greatest interpreter of nature's secrets and patterns.

Also, by the Cherokee, Lottie Jenkins tells us, grubworms were formerly employed as food. She states that they can be made into a delicious thick soup. She told that her husband once sat down to a meal of grub-worm soup, but he had no knowledge of what he was eating. He thought the soup very good until his Indian host advised him to "dig deep and get grubs." When he pulled up a fat grub, the thought of it was too

<sup>9</sup> HOLT, VINCENT. *Why not eat insects?* London, 1885.

much; he was unable to finish the meal. Another insect delicacy of the Cherokee is roasted cornworms.

It is only appropriate to relate here what Vincent Holt<sup>10</sup> has to say in general on insect-eating:

Whilst confident that the caterpillars, the grubs, the chafers, and the butterflies will never condescend to eat us, I am equally sure that on finding out how good they are (and what excellent virtues they possess), we shall right away gladly determine to cook and eat them! Moreover, what a welcome change it will be to the labourer's meal of bread and bacon day after day for him to get a savoury mess of fried cockchafers, or of dainty grasshoppers done on toast! In these respects the birds are much more sensible than ourselves; they well know the value of the fat chafer as food. With that joy the jaunty rooks pounce upon its luscious grubs when they follow the plough with long strides over the upturned lea! What a feast the wise creatures obtain when aloft on the wing, by devouring the fledged beetles swarming in the tall tree tops!

Sally Gordon told that the daddy-longlegs if swallowed would break up chills and that lice had been swallowed for yellow jaundice. This is apparently a parallel to an English usage recorded in the London Dispensatory (1695), "They are eaten by rustics for the jaundice and consumption; put alive into the meatus they provoke urine; *Vivis in penis organum intimissis ad ciendam urinam.*"

Josselyn has several comments on frogs.<sup>11</sup> One alludes to the pond frog. "They are of a glistening brass colour, and very fat, which is excellent for Burns and Scaldings, to take out the Fire, and heal them, leaving no scar; and is also very good to take away any Inflammation." The other to the tree frog. "There is also many times found upon the leaves of the Oake a creature like a frog, being thin as a leaf, and transparent, as yellow as gold, the English call them Tree-Frogs or Tree-Toads . . . they are said to be venomous, but they may be safely used, being admirable to stop women's overflowing courses hung about their necks in a Taffetie bag." Are we to suppose that this is pure fancy or "superstition"? Let us now stop at this point and explore deeper into the

significance of what might be listed as heathen practice. Indeed the skin glands of the batrachians are known to contain toxic compounds of medicinal value and oddly enough some of the substances from these glands are known to possess astringent and hemostatic properties. A word from a leading authority on the chemistry and properties of these substances is pertinent:<sup>12</sup>

That there is present in the toad an active, poisonous principle has been recognized since antiquity, and although the nature of the poison was endowed with various legendary beliefs throughout the middle ages, it has long been recognized that the venom of the toad has definite medicinal qualities. For centuries the Chinese have employed as a drug a dried preparation from a common toad. The remedy is known as Ch'an Su in China and as Senso in Japan. Ch'an Su is sold in the form of hard, dark brown cakes which were applied externally in the treatment of toothache, sinusitis, and hemorrhages of the gums. Dried and powdered toad skins were commonly used as a remedy for dropsy until Withering introduced the use of the foxglove drug. It has been known for nearly a century that the poison of the toad has a specific, digitalis-like action on the heart, the intravenous injection of very small doses in frogs promptly inducing a systolic standstill.

With respect to the drawing or astringent effect which would be of value on burns, and also to the bleeding-stopping effect, we have this note: "It is interesting that the Chinese drug Ch'an Su has been found to contain, in addition to the cardiotoxic agents, this pressor substance of recognized astringent and hemostatic properties."

To this day the value of the frog as a medicinal agent is apparent to the Cherokee of western North Carolina. Consider the information contributed by Moses Owl. He reveals that the "toad frog is good for goiter. The live toad is held against the chest until you sweat." A yellow juice is thereby produced which is supposed to relieve the goiter.

The Cherokee also eat the pond frogs, using them for soup after they are suitably dressed. Jesse Lambert relates that frog soup has been administered for whooping cough—"one half glass every day before breakfast until cough ceases." Moses Partridge, an

<sup>12</sup> FIESNER, L. F. *Chemistry of natural products related to phenanthrene*. Monogr. Ser. No. 70: 302-303. 1936.

<sup>10</sup> Ibid.

<sup>11</sup> Op. cit.

older member of the Cherokee group, has used this remedy effectively.

In connection with whooping cough, polecat (skunk) grease has been found effective. Nicker Jack George advises that one take a few drops internally. It is thought to cure a rattle cough.

Dropping into the southeastern area brings to view a number of food and medicinal oddities of an animal nature. In working here among the Indians, numerous notable items have emerged. Lincoln Harmon, a Nanticoke Indian of Indian River, Del., tells of the use of salt herring applied to arms, hands, or feet for fever. He states that he has known people to "get rid" of colds or grippe. The procedure is to go to a neighbor, in the language of Lincoln Harmon, to "get bait on. Put on hands or any part of body. One sits near a fire. Fish is considerably dried or parched when you take it off. Better not let one application be all, better put new ones on as fish dry up."

One is intrigued to find that similar usage was employed in Queen Elizabeth's time in England. The *Rich storehouse* (1596) contains this information, "For the swelling of the legs that comes on by cold or otherwise, take white herrings out of their pickle, and open them, and then lay the insides of the same herrings to the soles of your feet when you go to bed, and so let them remain all night; in the morning apply new ones again. Use this five or six times and the same will help you, *probatum est.*" For ague also it includes, "Take a herring that is well pickled, and split it on the belly side, and warm the same very hot, and lay it to both soles of the feet of the party grieved, and this will help immediately." This makes one wonder whether this is an Indian or an English practice. It may have been discovered independently by both groups or the Nanticoke may have learned it from early contact with the English.

Among the Nanticoke again, but this time from Asbury Thompson, an old herbalist of the group, the use of fish eyes is mentioned. He tells that fish eyes are good for bowel movements. "Take as pills, the cheapest kind," is his advice.

Asbury Thompson also told of a well-known remedy for rheumatism which is em-

ployed by the Nanticoke Indians. He advises, "Put fishingworms in bottle, let die, apply oil for stiff joints and rheumatism. Smells bad, but sure helps stiff joints." The Cherokee Indians of western North Carolina appreciate also the virtue of the earthworm. They take the flesh of "redworms" and apply to the body to draw out thorns. It is worth noting that biochemists<sup>13</sup> have given attention to the lipids (fats) of the earthworm, discovering fatty acids that enter into therapeutics. Furthermore, a bronchial (lung) dilating principle has been isolated.<sup>14</sup> So here again the Indians have made discoveries anciently known to them in their medical lore, but known only recently to the medical world at large.

Living in the shadows of the Great Smoky Mountains of North Carolina, the Cherokees have a high regard for the singular animal foods and animal medicines such as fishing worms, locusts, grubs, and salamanders. Mrs. Moses Owl has seen the red worm (eath worm) poultice employed in drawing out a thorn. "Just make your poultice of chopped up worms. Draws so powerfully, have to take off soon." According to Lottie Jenkins, the red worms have been used in making soups. She states that they are really not bad and form a gelatinous soup that is quite palatable and healthful. So in the economy of the Cherokee the earthworm is valuable both as a medicine and as food.

Another food item which is valuable to the Pamunkey is the mussel. Mussels are gathered from March to February in shoal water along shores of rivers, where, in a rising tide in about ten inches of water, they lie open. They are stewed or boiled or eaten raw; not gathered to last over or be preserved. Another mollusk utilized by the Pamunkey is the Kahonk (Conch), found only in the York River, 12 miles east of the present reservation, from West Point to the bay. They are found in low water, by feeling with the bare feet on sand below the low-tide line. They are roasted by being put on sticks of fire. They are never dried or smoked for preservation.

<sup>13</sup> LOVERN, JOHN A. *Biochem. Journ.* **34**: 709-711. 1940.

<sup>14</sup> CHOU, T. G., CHAND, C. C., and CHU, H. P. *Chinese Journ. Physiol.* **12**: 147-153. 1937.

A curious weather attribute is given to the "fever-ague" worm (woolly-bear) by the Nanticoke. By reading the color pattern one can predict the severity of the weather. The months represented in succession from head to tail of the worm are December, January, and February. Elwood Wright tells if there is much black on the head, cold weather is meant, if short black more moderate; of much tan, open month is signified. If it appears black on the head end, brown on other, December will be rough, January and February open. If reversed, December will be open, while January and February will be rough. If totally colored, he explained, "It hasn't fully got its stripes yet."

One wonders whether this is native to the Indian, for I have obtained from the English settlers in the Blue Ridge of Augusta County, Va., a knowledge of the "feeble worm" as they call it, foretelling the weather. Mrs. Jack Kelly, of Stuarts Draft Community, has observed that if the feeble worm is black on either end a cold winter will follow, but if black in the middle, a mild or in-between season will invariably occur. The Nanticoke, who, as their name implies, were great fishermen, called the spring peepers (*Hyla crucifer*) herring frogs because they would always announce the "running" of the herring in the spring.

ICHTHYOLOGY.—*A new anchovy of the genus Anchoviella from the Poti and Parnaíba Rivers of Brazil.* LEONARD P. SCHULTZ and RUI SIMÕES DE MENEZES.

Since Hildebrand (Bull. Bingham Oceanogr. Coll. 3 (art. 2): 1-165, figs. 1-72, 1943) published "A Review of the American Anchovies (Family Engraulidae)" four other papers have appeared or were not included in Hildebrand's revision that deal with South American Anchovies. These are: Fowler, Proc. Acad. Nat. Sci. Philadelphia 93: 124, fig. 2, 1941; *ibid.* 95: 311, fig. 1, 1943; Hildebrand and Carvalho, Copeia, 1948, no. 4: 285-296, figs. 1-4; and Schultz, Proc. U.S. Nat. Mus. 99: 37-54, figs. 4-8, 1949. After comparing the specimens of anchovies which form the basis of this contribution with the species described in the above papers and with related material in the U.S. National Museum collections, we have concluded that our specimens represent an unnamed species.

*Anchoviella potiana*, n. sp.

Fig. 1

*Holotype*.—U.S.N.M. no. 112081, from Poti and Parnaíba Rivers, Teresina, State of Piauí, Brazil, collected in September 1949 by Rui Simões de Menezes, standard length 113.7 mm, total length 136.5 mm.

*Paratypes*.—U.S.N.M. no. 112082, collected along with the holotype and bearing same data, 7 specimens, 107 to 118 mm in standard length. Also 8 specimens in collection of Serviço de Piscicultura, Fortaleza, Ceará, Brazil.

*Description*.—Detailed measurements were made on the holotype and 15 of the paratypes and these data are expressed in thousandths of the standard length in Table 1. Counts for the new species are recorded in Table 2.

Body compressed, deep, greatest depth at about dorsal origin, 3.1 to 3.4, and head 3.6 to 3.7, both in standard length; head shorter than greatest depth of body; snout bluntly pointed, projecting about  $\frac{1}{2}$  its length beyond tip of mandible, about  $\frac{2}{3}$  eye, only a little longer than pupil; eye about 4.0 to 4.2 in head; maxillary ending posteriorly in a truncate to a broadly rounded tip that reaches to but not past joint of mandible, contained about 1.3 to 1.4 in head; mandible pointed, slightly curved dorsally at tip, reaching a vertical line a little behind rear edge of posterior nasal margin; teeth minute, very numerous, along edges of both jaws, cheek 7.0 to 8.2 and postorbital length of head 5.5 to 5.8 in standard length; angle of cheek varies from 35° to 44°; gill rakers long, slender, the longest about 3 times in postorbital length of head, each gill raker on the first four arches with two rows of numerous minute spinules on the inner or posterior side; no gill rakers on the posterior side of the first three arches, but short rakers occur on posterior side of fourth gill arch; depressed length of dorsal fin 1.4 to 1.5 in head; the first branched rays of dorsal fin reaching to opposite or not quite to tip of last dorsal ray when fin is depressed; distal margin of dorsal slightly concave when

TABLE 1.—MEASUREMENTS MADE ON SPECIMENS OF ANCHOVIELLA POTIANA, N. SP., RECORDED IN THOUSANDTHS OF STANDARD LENGTH

Measurements	Measurements by Schultz <sup>1</sup>							Measurements by Menezes <sup>1</sup>							
	Holo-type	Paratypes						Paratypes							
Standard length in millimeters.....	113.7	113	107	111	109	111.4	118	103	112	115	104	109	104	109	109
Greatest depth.....	321	315	302	313	323	303	316	320	303	296	308	312	308	321	321
Length of head.....	282	286	278	270	278	278	263	252	250	252	250	248	260	239	239
Postorbital length of head.....	175	186	171	173	179	170	178	145	161	156	154	147	163	147	147
Snout.....	46	44	51	43	44	45	47	58	45	43	48	55	58	46	46
Eye.....	73	65	70	75	72	73	69	68	62	61	67	64	67	73	64
Length of mandible.....	187	192	192	186	189	186	191	155	152	156	144	156	173	156	165
Longest gill raker.....	64	63	69	59	62	60	64								
Interorbital (bony) space.....	67	59	65	62	62	65	58	78	80	78	77	73	77	73	73
Tip of snout to: Rear edge of maxillary.....	219	217	221	203	211	209	210	214	205	213	221	206	221	211	211
Dorsal origin.....	519	514	500	504	517	516	508	534	518	513	519	514	519	541	514
Anal origin.....	627	638	650	624	657	605	624	640	625	617	673	624	654	642	642
Length of anal fin base.....	282	269	280	266	279	269	267	281	285	278	288	275	288	284	284
Length of dorsal fin base.....	121	127	118	122	127	135	131	136	125	139	135	138	144	128	138
Length of pectoral fin.....	180	165	171	173	185	168	176	175	179	178	173	183	173	183	183
Length of pelvic fin.....	102	99	106	106	114	97	105	97	107	104	111	101	111	106	106
Length of pectoral axillary scale.....	104	89	106	110	84	114	93	97	98	96	106	101	96	83	101
Least depth of caudal peduncle.....	123	124	125	117	125	124	119	116	125	113	115	119	125	119	119

<sup>1</sup> Differences between the two sets of figures such as head length, postorbital length of head, length of mandible, interorbital space, and length of dorsal fin base are probably caused by different methods of measuring.

TABLE 2.—COUNTS RECORDED FOR ANCHOVIELLA POTIANA, N. SP.

Number of fin rays															
Dorsal			Anal				Pectoral			Pelvic			Branched caudal		
													Dorsal lobe	Ventral lobe	
iii	10	11	iii	22	23	24	25	i	11	12	i	5	6	9	8
16	7	9	16	2	8	5	1	16	4	12	23	2	21	15	15

Number of scales

Vertical rows from gill opening to caudal base			Dorsal origin to mid-ventral line	
41	42	43	8	9
10	5	1	10	5

Number of gill rakers on first arch

Above angle						Below angle										
47	48	49	50	51	52	51	52	53	54	55	56	57	58	59	60	61
2	3	2	2	4	3	1	—	1	1	3	2	3	4	—	—	1



distended; caudal fin deeply forked; distal margin of anal fin concave anteriorly, first anal rays longest; first dorsal ray of pectoral fin longest; tips of pectoral fins reaching to or not quite to insertion of pelvics; pelvic fins reaching about  $\frac{1}{2}$  to  $\frac{3}{4}$  the way to the anal origin; dorsal fin origin about equidistant between tip of snout and base of caudal fin; origin of anal fin about under base of last or next to last dorsal ray; axillary scale of pectoral fin extending one-half to two-thirds the way along length of pectoral fin; intestine with one main loop.

*Color in alcohol.*—Straw-colored in alcohol dorsally, sides and belly silvery; dorsal side and tip of snout with black pigment, predorsal area of back with dark pigment intensified just behind occiput to form a blotch and then another just in front of dorsal origin; rear margin of caudal fin dusky; upper sides and back with some dusky pigmentation.

*Remarks.*—This new species is chiefly characterized by its numerous gill rakers on both limbs of the arches in conjunction with other characters which make it referable to the genus *Anchoviella*, such as lack of gill membranes across isthmus, presence of very numerous minute teeth on edges of both jaws; origin of anal behind that of dorsal fin; long, slender, numerous gill rakers on both limbs of gill arches; vertebrae about 41; one main loop of intestine; anal origin under rear of base of dorsal fin; maxillary broadly rounded or truncate posteriorly and not reaching past joint of mandible; dorsal origin about equi-

distant between tip of snout and base of caudal fin.

The occurrence of 47 to 52 + 51 to 61 gill rakers on the first gill arch of any species referable to the genus *Anchoviella* might cause one to cast doubt on our generic allocation, but comparing this new species with various members referred to the other genera of American anchovies leaves no doubt in our mind that *potiana* is an *Anchoviella*. The details of the gill rakers, long, slender, with the two rows of fine spines on inner edge, and shape of maxillary among other characters remove it from the genus *Anchovia*, which also has species with very numerous gill rakers, but a posteriorly pointed maxillary.

*A. potiana* would run down through Hildebrand's key to the species of *Anchoviella* on pp. 109–111 closest to *A. pallida* but does not agree with that species because *pallida* has 28 to 34 + 36 to 45 gill rakers and *potiana* has 47 to 52 + 51 to 61 on first gill arch. Fowler (1941, *l.c.*) described *Anchoviella iheringi* from the Rio Jaguaribe, Brazil, and this was not included in Hildebrand's revision but it has only 14 + 19 gill rakers, far too few to be close to *potiana*. Hildebrand and Carvalho (1948, *l.c.*) described two new species of *Anchoviella* from Brazil, *A. victorae* and *A. nitida*, with 21 to 23 + 29 to 33 and 18 to 20 + 23 or 24, respectively, on first gill arch of both species. Thus *victorae* and *nitida* are not close to *potiana*. We have not noticed any other species of *Anchoviella* in the literature.

Named *potiana* after the Poti River of Brazil.

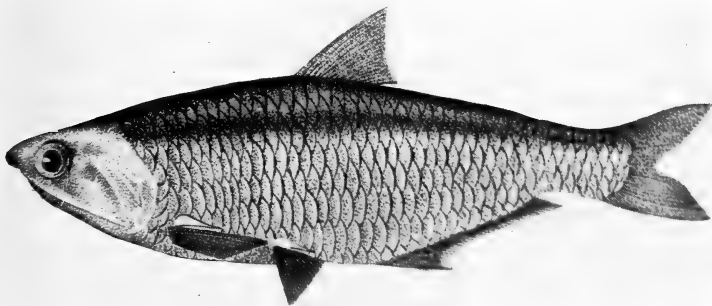

FIG. 1.—Drawing of one of the paratypes of *Anchoviella potiana*, new species, by Mario Dias-Maia, Serviço de Piscicultura, Fortaleza, Ceará, Brazil.

PROCEEDINGS OF THE ACADEMY  
53D ANNUAL MEETING

The 53d Annual Meeting, concurrently with the 376th monthly meeting of the Academy, was held as a dinner meeting in the Ballroom of the Kennedy-Warren on the evening of January 18, 1951. President F. B. SILSBEE presided.

After the dinner, Dr. Silsbee called the meeting to order. The minutes of the 52d Annual Meeting were approved as published in the *Journal* 40: 198-205, 1950.

The following reports by the various officers, committee chairmen, auditors, and tellers were read and approved:

REPORT OF THE SECRETARY

During the Academy year—January 29, 1950, to January 18, 1951—125 persons were elected to regular membership, including 114 to resident and 11 to nonresident (56 were elected last year). Of these, 84 resident and 7 nonresident qualified for membership. Ten resident members elected to membership in the preceding Academy year qualified during the present Academy year just ended. The new members were distributed among the various sciences as follows: 24 in physics, 21 in chemistry, 12 in entomology, 7 in zoology, 5 in mathematics, 4 in engineering, 2 each in bacteriology, geophysics, biochemistry, and mammalogy, and 1 each in paleontology, electrical engineering, geology, anthropology, mineralogy, botany, medicine, geodesy, mechanical engineering, and astronomy.

Nine resident members and one nonresident member, having retired from the gainful practice of their professions, were placed on the retired list of members to enjoy the privileges of active membership without further payment of dues. Eight resident members and one nonresident member resigned in good standing.

The deaths of the following members were reported to the Secretary:

- GEORGE S. RICE, Alexandria, Va., on January 3, 1950.  
CLARENCE A. REED, Takoma Park, Md., on January 14, 1950.  
HENRI F. PITTIER, Caracas, Venezuela, on January 27, 1950.  
CARLOS DE LA TORRE, Habana, Cuba, on February 19, 1950.  
OAKES AMES, Cambridge, Mass., on April 28, 1950.  
L. O. HOWARD, Washington, D. C., on May 1, 1950.

HOWARD S. REED, Berkeley, Calif., on May 12, 1950.

HERBERT S. BARBER, Washington, D. C., on June 1, 1950.

EDWARD A. BIRGE, Madison, Wis., on June 9, 1950.

FRANK W. SCHWAB, Washington, D. C., on June 18, 1950.

M. A. RAINES, Washington, D. C., on July 1, 1950.

C. W. WARBURTON, Washington, D. C., on September 22, 1950.

CHESTER STOCK, Pasadena, Calif., on December 6, 1950.

JOHN F. EMBREE, New Haven, Conn., on December 22, 1950.

H. E. EWING, Takoma Park, Md., on January 5, 1951.

HENRI F. PITTIER, CARLOS DE LA TORRE, and L. O. HOWARD were honorary members.

On January 18, 1951, the status of membership was as follows:

	<i>Regular</i>	<i>Retired</i>	<i>Honorary</i>	<i>Patron</i>	<i>Total</i>
Resident.....	573	57	0	0	630
Nonresident.....	173	34	10	0	217
Total.....	746	91	10	0	847

The net changes in membership during the past year are as follows:

	<i>Regular</i>	<i>Retired</i>	<i>Honorary</i>	<i>Patron</i>	<i>Total</i>
Resident.....	+58	+7	-1	0	+64
Nonresident.....	+14	+1	-2	0	+13
Total.....	+72	+8	-3	0	+77

During the Academy year 1950 the Board of Managers held 9 meetings, with an average attendance of 18 persons. The following important matters were considered:

At the 435th meeting, held on February 20, 1950, the Board approved the sale of 818 shares of Washington Sanitary Improvement Co. stock. [On June 20, 1950, the stock was sold at a price considerably higher than what the Academy paid for it many years ago.]

The Academy was represented at the Seventh International Botanical Congress, held at Stockholm, Sweden, July 12-20, 1950.

At the 439th meeting, September 25, 1950, the Board instructed the Secretary to prepare and mail to the membership a request for changing Article II, Section I, of the bylaws, increasing the number of active members from 750 to 1,000, and resident membership from 600 to 800. In

all, 389 ballots were returned, of which 374 voted in favor of the amendment, 11 opposed, 3 were unvoted, and 1 did not vote. The need for this increase in membership was due to a large extent to the very active Committee on Membership, as indicated by the election of 125 scientists to regular membership.

During the Academy year, eight meetings of the Academy were held, as follows:

On February 16, 1950, FRANK H. H. ROBERTS, JR., Bureau of American Ethnology, delivered his retiring presidential address on *Archeology and the modern world*.

On March 16, 1950, the 1949 Academy Awards were presented to EDWARD G. HAMPP, National Institutes of Health, for work in the biological sciences; RICHARD K. COOK, National Bureau of Standards, for work in the engineering sciences; and to JOHN A. HIPPLE, National Bureau of Standards, for work in the physical sciences. The Academy awarded Certificates of Merit to six outstanding local high-school science students: MILES DAVIS, Central High School; WILLIAM EDWARD DRISSEL, Gonzago High School; PHIL STRATFORD WORK, Western High School; PATRICIA MORSE FEDERICO, Woodrow Wilson High School; DONALD JASON BYERS, Woodrow Wilson High School; and PAUL DOUGLAS SHEATS, Woodrow Wilson High School.

On April 20, 1950, THOMAS WALLER GEORGE, Naval Research Laboratory, addressed the Academy on *Dynamical aspects of plastic flowing in solids*.

On May 18, 1950, FRANK M. SETZLER, U. S. National Museum, addressed a joint meeting of the Academy and the Anthropological Society of Washington on *Aboriginal Australia*.

On October 19, 1950, CHARLES ARMSTRONG, National Institutes of Health, addressed the Academy on *Poliomyelitis: Its occurrence and behavior in our population*.

On November 30, 1950 JAMES A. VAN ALLEN, Johns Hopkins University Applied Physics Laboratory, addressed the Academy on *New Experiments in the upper atmosphere*.

On January 18, 1951, PER K. FROLICH, Merck & Co., gave an after-dinner talk to the Academy on *Medicinal chemicals*.

Six of the meetings were held in the Cosmos Club. The joint meeting with the Anthropological Society of Washington was held in the auditorium of the U. S. National Museum. The meeting on

January 18, 1951, was held at the Kennedy-Warren.

The Academy sponsored the annual Science Fair for high school students and the weekly issue of the Science Calendar in the local newspapers.

FRANK M. SETZLER.

REPORT OF THE TREASURER

The Treasurer submits the following report concerning the finances of the Washington Academy of Sciences for the year ended December 31, 1950:

		RECEIPTS	
Dues, 1949	.....	\$73.00	
1950	.....	3,788.00	
1951	.....	124.00	\$3,985.00
<hr/>			
Journal, Subscriptions,			
1946	.....	6.00	
1947	.....	7.50	
1948	.....	7.50	
1949	.....	21.75	
1950	.....	611.24	
1951	.....	680.45	
1952	.....	5.06	1,339.50
<hr/>			
Reprints,			
1949	.....	201.57	
1950	.....	568.53	770.10
<hr/>			
Sales,			
1950	.....	93.43	
Interest and dividends	.....	1,521.50	
Directory (33d ed.)	.....	6.00	
Monograph no. 1	.....	189.67	
Transferred from invested funds	...	1,000.00	
Transferred from Savings Account	.....	25,000.00	
Annual dinner (1950)	.....	294.00	
Refund, service charge, A. S. & T. Co.	.....	7.43	
Sale Washington Sanitary Improvement Co. Stock	.....	26,114.65	
<hr/>			
Total receipts, 1950	.....	\$60,321.28	
Cash balance, January 1, 1950	..	1,635.53	
			<hr/>
			\$61,956.81

DISBURSEMENTS

	1949	1950	Total
Secretary's Office	\$110.87	\$370.39	\$481.26
Treasurer's Office		304.59	304.59
Subscription Manager & Custodian of Publications	8.95	21.72	30.67
Meetings Committee	35.50	208.80	244.30

Membership Committee.....	1.00	.50	1.50
Journal			
Printing & mailing.....	613.28	4,887.38	5,500.66
Illustrations.....	68.76	521.91	590.67
Reprints.....	246.66	673.16	919.82
Office			
Editorial Asst.....	25.00	275.00	300.00
Miscellaneous.....	1.58	42.83	44.41
	\$1,111.60		

Annual Dinner (1950)			
Tickets and programs.....	25.00		
Refunds.....	10.50		
Hotel 2400.....	274.20		
Projection Service.....	18.50	328.20	
Monograph no. 1			
Postage, wrapping, etc.....	3.08	3.08	
40-year Index.....	1,000.00	1,000.00	
Science Fair.....	100.00	100.00	
Science Calendar.....	10.00	10.00	
Fireproof records cabinet.....	263.00		
and material for base.....	1.66	264.66	
George Banta Publishing Co.			
Cartage on overcopies.....	69.93	69.93	
Deposited in Savings Account.....	26,114.65	26,114.65	
Stock			
Massachusetts Investors Trust, 400 shares @ \$33.62.....	13,448.00		
Investment Co. of America, 400 shares @ \$11.61.....	4,644.00		
State Street Investment Corporation, 100 shares @ \$61.25.....	6,125.00	24,217.00	
Debit memos:			
1378 A \$0.89 (exchange)			
1388 A 7.43 (service charge)			
1423 A 0.56 (exchange).....	8.88	8.88	
Total disbursements.....	\$59,422.68	60,534.28	
Cash book balance as of December 31, 1950.....		1,422.53	
Total.....		\$61,956.81	

## RECONCILIATION OF BANK BALANCE

Balance as per cash book, Dec. 31, 1950.....		\$1,422.53	
Balance as per Amer. Sec. & Trust Co. Statement of Dec. 18, 1950.....	\$1,373.36		
Receipts undeposited.....	1,227.18		
Total.....	\$2,600.54		
Checks outstanding, as of Dec. 31, 1950			
No. 1018.....	\$5.41		
1263.....	5.00		
1429.....	1,144.02		
1430.....	23.58	1,178.01	\$1,422.53

## INVESTMENTS

<i>Potomac Electric Power Co.</i>			
Certificate No. TAO 1977—40 shares			
3.6% pref. at \$50.....			\$2,000.00
<i>City of New York—3%</i>			
(Transit Unification)			
Due—June 1, 1980			
Certificate No.			
D 20186.....	\$500.00		
C 71038.....	100.00		
C 71039.....	100.00		
C 71040.....	100.00		\$800.00

<i>First Federal Savings &amp; Loan Assn.</i>			
Investment account book.....			\$1,000.00
<i>Northwestern Fed. Savings &amp; Loan Assn.</i>			
Certificate No. 1380.....	\$4,500.00		
1441.....	500.00		\$5,000.00

*United States Government*

Series G Bonds—			
No. M 332990 G.....	1,000.00		
M 332991 G.....	1,000.00		
M 332992 G.....	1,000.00		
M 332993 G.....	1,000.00		
M 1808741 G.....	1,000.00		
M 2226088 G.....	1,000.00		
M 2982748 G.....	1,000.00		
M 4126041 G.....	1,000.00		
M 5141346 G.....	1,000.00		
M 5141347 G.....	1,000.00		\$10,000.00

<i>Massachusetts Investors Trust</i>			
400 shares at \$33.62.....			\$13,448.00
<i>Investment Co. of America</i>			
400 shares at \$11.61.....			\$4,644.00
<i>State Street Investment Corp.</i>			
100 shares at \$61.25.....			\$6,125.00
<i>American Security &amp; Trust Co.</i>			
Savings Account.....			\$1,161.52
Total.....			\$44,178.52
Cash balance 12/31/50.....			1,422.53

Total.....			\$45,601.05
Total as of Dec. 31, 1949.....	\$29,662.40		
Total as of Dec. 31, 1950.....		45,601.05	
Increase.....		\$15,938.65	

At the close of business on December 31, 1950, there were 52 members of the Academy in arrears, 34 for 1 year, 8 for 2 years, 2 for 3 years, 7 for 4 years, and 1 for 5 years.

HOWARD S. RAPPLEYE.

## REPORT OF AUDITING COMMITTEE

The accounts of the Treasurer of the Washington Academy of Sciences for the year 1950 were

examined by your auditing committee on January 10, 1951.

A copy of the Treasurer's report was checked and found to be in agreement with the records. All disbursements had been previously authorized and are supported by vouchers or cancelled checks.

The securities of the society were inspected on January 11, 1951, and found to be in agreement with the list given in the report and to have all coupons attached that are not yet due.

The work of the committee was greatly simplified and lessened by the excellent manner in which the records have been kept and by the systematic and orderly arrangement of the books and of the report. Your Treasurer deserves the commendation of the Society for another year of service to the Academy.

(One member of the auditing committee, DR. C. L. GAZIN, was unable to assist in the audit because of his absence from the city.)

RAYMOND L. SANFORD.

WALTER D. SUTCLIFFE, *Chairman*

#### REPORT OF THE BOARD OF EDITORS

Volume 40 of the JOURNAL, for the year 1950, contained 424 printed pages, 4 less than volume 39 for 1949, despite which the cost of issuing the JOURNAL has again increased. The higher costs in 1950 are caused by the inflationary spiral of prices which began in July with the start of the war in Korea. The increases reflect the higher prices of paper and materials for which the contract specifies a cost plus basis. Reluctantly, the printer, Waverly Press, Inc., has requested permission to increase by ten per cent the rates on items specified by price in the contract, the increase to go into effect in January 1951; it is made necessary by higher wages and other cost increases. Waverly Press is to be commended for the equitable treatment it has given the JOURNAL in this matter.

During 1950 the JOURNAL published 81 submitted papers and 12 obituaries, together with proceedings of the ACADEMY and of two affiliated societies. The submitted papers comprized 66 in biological sciences, 6 in mathematics and the physical sciences, and 9 in other sciences. In addition to these, there were 16 abstracts of papers in the Proceedings of the Philosophical Society of which 10 were in physics, 2 in astrophysics, 1 in biophysics, 1 in medicine, 1 in mathematics, and 1 in fuel research.

The disbursements for the JOURNAL during 1950 were:

Printing, mailing, engraving, etc.....	6,011.95
Reprints.....	822.00
Office—Editorial assistant.....	300.00
Office—Miscellaneous.....	30.79
Total.....	7,164.74
Charges to authors.....	954.73
Net cost of the JOURNAL to Academy.....	6,210.01

In 1949 the net cost to the Academy was \$6,013.84, \$196.17 less than for the current year.

The Board of Editors wishes to acknowledge the cooperation of the Board of Managers and the officers of the Academy. Special thanks are due to MR. PAUL H. OEHSER who efficiently handles all matters pertaining to the technical side of printing and make-up of the JOURNAL. The Editors also wish to thank MR. FRANCIS C. HARWOOD, of Waverly Press, for his helpful suggestions.

FRANK C. KRACEK.

FREDERICK J. HERMANN.

WILLIAM F. FOSHAG.

#### REPORT OF CUSTODIAN AND SUBSCRIPTION MANAGER OF PUBLICATIONS

##### *Subscriptions*

Nonmember subscriptions in the United States and possessions.....	145
Nonmember subscriptions in foreign countries.....	82
Total.....	227

This represents a gain of 4 subscriptions over last year's total.

##### *Inventory of stock as of December 31, 1950*

<i>Reserve sets of the Journal</i>	
Complete sets, vols. 1-40.....	4 sets
Volumes 11-40.....	6 sets
16-40.....	9 sets
21-40.....	5 sets

Total sets more or less complete..... 25 sets

##### *Back numbers of the Journal*

Numbers held in complete sets (4)..... 2,652

Numbers held in reserve for complete sets..... 8,263

Numbers held for sale separately..... \*

Total numbers on hand..... \*

\* A count of these separate numbers has not been made recently, pending a rearrangement of the back stock and a subsequent recount and audit.

*Proceedings*

Complete sets, volumes 1-13 (1899-1911) 48 sets  
(The copies of the separate articles that appeared in the Proceedings have not been counted.)

*Monograph no. 1*

Original issue .....	1,010
Copies sold or otherwise distributed....	141

Number of copies on hand .....	869
--------------------------------	-----

*Sales*

During the year 1950, sales of the JOURNAL and PROCEEDINGS fell well below the sales recorded in 1949. No complete sets of the PROCEEDINGS were sold, and only 115 numbers of the JOURNAL were sold either separately, or as volumes.

Seven numbers of the PROCEEDINGS and three copies of the 1947-48 Directories were sold.

The sales of the Monograph fell off from those the previous year. This year 47 copies were sold. It was not possible to circularize prospective buyers during 1950 but it is expected to do this early in 1951. This it is hoped will increase the sales of the Monograph.

A gift of an almost complete set of the JOURNAL from the estate of the late Joseph A. Cushman and numerous other very welcome gifts of early numbers of the JOURNAL, have given us a good start toward making up another complete set. It is hoped that the older members who are considering the distribution of their library will remember the needs of the Academy in this respect.

The income from sales of copies of the JOURNAL, Proceedings, and Directory was \$93.43, while sales of the Monograph yielded \$189.67. This is a total income of \$283.10.

*Expenditures*

Supplies .....	\$6.50
Stamped Envelopes .....	.91
Postage expended in connection with the JOURNAL, etc. ....	6.60
Postage expended in connection with the Monograph .....	5.53
Total .....	\$19.54

*Storage*

In last year's annual report it was mentioned that a rearrangement of the storage facilities that we have in the Smithsonian Institution Building was in progress. It was impossible to finish this in the limited free time at the disposal of the custodian, but it is expected that this work will

be finished during 1951. At that time it will be possible to have a count made of the stock on hand.

HARALD A. REEDER.

## REPORT OF THE ARCHIVIST

During the year the present incumbent with the active cooperation of his predecessor worked over all Academy materials heretofore turned in for deposit in the Academy's Archives. Much material of an ephemeral nature has been discarded and the remainder reorganized and rearranged so that it is hoped that the files will be readily usable hereafter. An itemized inventory of the materials in hand follows:

Scrapbook containing miscellaneous printed matter of the Academy, including notices of meetings, 1898-1922, inclusive.

Folder containing similar material since 1922. Very far from complete. Presumably a complete collection from 1923 to date is in Secretary's possession.

Red Books: Vol. 1 (1892, 1895, 1897, 1898, 1900). Unbound 1899, 1901, 1903, 1905, 1907, 1909. Vol. 2 (1911-1919) Red Books only, Nos. 18-22. Vol. 3 (1921-1935) Red Books Nos. 23-29 with Academy lists 1914, 1916, 1918, 1920, 1922, 1926. Unbound 1937, 1939, 1941, 1947-8 with Academy lists 1916, 1918, 1920, 1922, 1924, 1926.

Membership records, 1898-1948. Includes all pertinent records available on all members, including applications, acceptances, resignations, declinations, etc.

The Benjamin Franklin Medal presented to the Academy by the American Philosophical Society, commemorating 200th anniversary of his birth.

Original ballots with tally sheets, covering selection of charter members of the Academy, 1898. In wrapped package.

Personal data (names, addresses, degrees, etc.) of Academy members, 1901. In wrapped package. Recording Secretary's minute book from January 1908 (48th meeting) to January 1936, inclusive (268th meeting) (10th-38th Annual meetings). Bound.

Minutes of the meetings of the Board of Managers, January 31, 1911-December 19, 1929, inclusive (165th-301st meetings). Bound.

Same. January 29, 1930-December 16, 1938 (302nd-349th meetings). Bound.

Same. February 10, 1939-October 18, 1943 (350th-385th meetings). Bound.

Same. 1st, 193, 287-399, in folder (unbound).

Treasurer's books:

Membership dues, 1898-1907, alphabetically by names.

Treasurer's cash books (receipts and disbursements).

- (1) Feb. 1898-Dec. 1909.
- (2) Jan. 1910-Dec. 1915.
- (3) Jan. 1916-Dec. 1935.
- (4) Jan. 1916-Dec. 1918 (receipts only)
- (5) Jan. 1919-Dec. 1921 " "
- (6) Jan. 1922-June 1925 " "
- (7) June 1925-Sept. 1933 " "
- (8) Oct. 1933-Dec. 1936 " "
- (9) Ledger 1917-1928
- (10) "Cash book" 1915-1927. A mess:
- (11) " " " 1928-1934
- Letterpress books (nos. 2-7) Nov. 1, 1900-Jan. 17, 1922.
- Volume 1 is missing.
- Journal Washington Academy of Sciences
- Volumes 1-30. Bound 1912-1940. 31-38. Unbound 1941-1948, 1949, 1950.
- Proceedings Washington Academy of Sciences
- Volumes 1-13 (1899-1911). *Bound.*
- Proceedings The McGee Memorial Meeting.
- Washington Academy of Sciences, Dec. 5, 1913. 1916. (2 copies) *Unbound.*
- Lectures on heredity. Reprints from Journal Washington Academy of Sciences, Bound in boards. 1917.
- Lectures on scientific and engineering aspects of the war. Reprints from Journal Washington Academy of Sciences. Bound in boards. 1918.
- Photographs, Past-Presidents, Washington Academy of Sciences.
- Half-tone cuts used for portrait illustrations in Red Book, 1947-48 (4 boxes).
- Original photographs as above, mounted on large cards (one large package).
- Facsimile copy of the charterbook and signatures in the first journal book of the Royal Society of England. 1912. Folio. Presented to the Academy by the Royal Society.
- Reports of officers: Archivist, Auditors, Custodian of Publications, Editors, Recording Secretary, Secretary and Corresponding Secretary, Tellers, Treasurer.
- Reports of Annual Meetings.
- Academy awards, Miscellaneous records of.
- Records of academy delegates to scientific congresses, etc.
- Correspondence in re publication of Proceedings of the Academy, 1901-1912.
- Correspondence in re publication of Red Book.
- Correspondence in re publication of JOURNAL.
- Applications for affiliation of scientific societies and action taken thereon.
- Membership lists.
- Lists of past officers.
- Formation and early history of the Academy.
- Amendments proposed to bylaws.
- Scientific societies of the Washington area (1936 questionnaire).
- Committee reports, attendance at scientific meetings, Botanic Garden, honorary foreign memberships, executive, finance, JOURNAL, meetings, meeting places, membership, nominating, publication, miscellaneous.
- Miscellaneous folders on District of Columbia,

Kober lectureship, presentation of medals, directions for operating Hare system, American Association for the Advancement of Science, American Metric Association, popular books in science, engraving Academy notification forms. Miscellaneous unsorted correspondence.

JOHN A. STEVENSON.

The President then announced the recipients of the Academy Awards for 1950 as recommended by the Committee on Awards for Scientific Achievement and approved by the Board of Managers:

*Biological Sciences:* DAVID H. DUNKLE, U. S. National Museum, in recognition of his distinguished service in paleontology, especially by researches on early arthrodiran and teleost fishes.

*Engineering Sciences:* SAMUEL LEVY, National Bureau of Standards, in recognition of his distinguished service in the structural analysis of aircraft.

*Physical Sciences:* PHILIP H. ABELSON, in recognition of his distinguished service in the fields of chemistry, nuclear physics, and in the physics of living organisms.

REPORT OF THE COMMITTEE ON MEMBERSHIP

During the Academy year, the Committee on Membership held six meetings and processed 124 nominations for membership. Seventy of these represented the physical sciences, 44 the biological sciences, and 10 the engineering sciences. One hundred and twelve of these nominations were for resident membership and 12 for nonresident. The scientific background and achievements of each nominee were abstracted and presented to the Board of Managers at its regular meetings.

The Chairman wishes to express his thanks to all the members of the committee for their kind cooperation in the work, and to the President, Secretary, and members of the Board for their many helpful suggestions.

ROGER G. BATES, *Chairman.*

REPORT OF COMMITTEE ON ENCOURAGEMENT OF SCIENCE TALENT

The Committee arranged for the participation of the Academy in the Ninth Science Talent Search of the Westinghouse Educational Foundation, as sponsor of the Second Annual Talent Search in the District of Columbia. In continuance of this custom the committee has also started preliminary work for the Tenth Science Talent Search.

Last year's search resulted in the recommendation by the committee of six local participants in the national search to the Academy's Board of Managers for the award of a Certificate of Merit from the Academy. The awards were presented by the Academy at its Annual Honors Meeting in March 1950. Letters of recommendation from the Academy for scholarship awards were sent to the universities of choice of the award recipients.

The Academy, through the medium of the committee, again sponsored the Annual Science Fair for local high and junior high school students, in cooperation with the Science Departments of the Public Schools of the District of Columbia. The fair was held May 15-19, 1950, in the lobby of the Department of Commerce Building, with 564 exhibitors selected from about 1500. Thirty-six winners were presented Certificates of Award by the President of the Academy, after selection by a group of judges from the Academy.

The expenses of the committee consisted of \$115 representing the Academy's contribution to support the Fourth Annual Science Fair.

The membership of the Committee during the year was: DR. B. D. VAN EVERA; DR. A. T. MCPHERSON; DR. FRED MOHLER; AUSTIN H. CLARK; JOSEPH M. CALDWELL, and DR. M. A. MASON, Chairman.

MARTIN A. MASON, *Chairman*.

After acceptance by the members of the report read by the Chairman of the Committee of Tellers, the President declared the following individuals elected to the given offices:

WALTER RAMBERG, *President-Elect*  
FRANCIS M. DEFANDORF, *Secretary*  
HOWARD S. RAPPELVEY, *Treasurer*  
SARA E. BRANHAM and JOHN A. STEVENSON,  
*Board of Managers to January 1954*

The following members of the Academy, nominated by the Affiliated Societies, were duly elected Vice-Presidents of the Academy:

Philosophical Society of Washington—EDWARD U. CONDON  
Anthropological Society of Washington—WALDO R. WEDEL  
Biological Society of Washington—[Vacancy]

Chemical Society of Washington—JOSEPH J. FAHEY  
Entomological Society of Washington—FREDERICK W. POOS  
National Geographic Society—ALEXANDER WETMORE  
Geological Society of Washington—LEASON H. ADAMS  
Medical Society of the District of Columbia—[Vacancy]  
Columbia Historical Society—GILBERT GROSVENOR  
Botanical Society of Washington—E. H. WALKER  
Washington Section, Society of American Foresters—WILLIAM A. DAYTON  
Washington Society of Engineers—CLIFFORD A. BETTS  
Washington Section, American Institute of Electrical Engineers—FRANCIS M. DEFANDORF  
Washington Section, American Society of Mechanical Engineers—RICHARD S. DILL  
Helminthological Society of Washington—L. A. SPINDLER  
Washington Branch, Society of American Bacteriologists—ANGUS M. GRIFFIN  
Washington Post, Society of American Military Engineers—HENRY W. HEMPLE  
Washington Section, Institute of Radio Engineers—HERBERT G. DORSEY  
District of Columbia Section, American Society of Civil Engineers—[Vacancy]

The President introduced the speaker, PER K. FROLICH, Vice-President of Merck & Co. DR. FROLICH gave an illustrated talk on *Medicinal chemicals*. He outlined the various procedures followed in producing, under rigid requirements of purity, the various antibiotics, vitamins, and other life-saving chemicals. He reviewed the various steps required to produce these medicinal compounds, from the minute quantities obtained in the original fundamental research laboratories to the very large scale production of many tons per day. These operations require great teamwork on the part of many related disciplines.

The retiring President, F. B. SILSBEE, expressed his appreciation to the officers, to the Board of Managers, and to the various committee chairmen for their work and cooperation throughout the year. He then introduced the new President, NATHAN R. SMITH, who had served as President-Elect during 1950. After a few interesting remarks the new President adjourned the meeting at 10:15 P. M.

FRANK M. SETZLER, *Secretary*.



## Officers of the Washington Academy of Sciences

<i>President</i> .....	NATHAN R. SMITH, Plant Industry Station
<i>President-elect</i> .....	WALTER RAMBERG, National Bureau of Standards
<i>Secretary</i> .....	F. M. DEFENDORF, National Bureau of Standards
<i>Treasurer</i> .....	HOWARD S. RAPPLEYE, U. S. Coast and Geodetic Survey
<i>Archivist</i> .....	JOHN A. STEVENSON, Plant Industry Station
<i>Custodian and Subscription Manager of Publications</i>	HAROLD A. REHDER, U. S. National Museum
<i>Vice-presidents Representing the Affiliated Societies:</i>	
Philosophical Society of Washington.....	EDWARD U. CONDON
Anthropological Society of Washington.....	WALDO R. WEDEL
Biological Society of Washington.....	
Chemical Society of Washington.....	JOSEPH J. FAHEY
Entomological Society of Washington.....	FREDERICK W. POOS
National Geographic Society.....	ALEXANDER WETMORE
Geological Society of Washington.....	LEASON H. ADAMS
Medical Society of the District of Columbia.....	
Columbia Historical Society.....	GILBERT GROSVENOR
Botanical Society of Washington.....	E. H. WALKER
Washington Section, Society of American Foresters.....	WILLIAM A. DAYTON
Washington Society of Engineers.....	CLIFFORD A. BETTS
Washington Section, American Institute of Electrical Engineers	FRANCIS M. DEFENDORF
Washington Section, American Society of Mechanical Engineers.....	RICHARD S. DILL
Helminthological Society of Washington.....	L. A. SPINDLER
Washington Branch, Society of American Bacteriologists.....	ANGUS M. GRIFFIN
Washington Post, Society of American Military Engineers.....	HENRY W. HEMPLE
Washington Section, Institute of Radio Engineers.....	HERBERT G. DORSEY
District of Columbia Section, American Society of Civil Engineers.....	
<i>Elected Members of the Board of Managers:</i>	
To January 1952.....	W. F. FOSHAG, C. L. GAZIN
To January 1953.....	C. F. W. MUESEBECK*, A. T. MCPHERSON
To January 1954.....	SARA E. BRANHAM, MILTON HARRIS*
<i>Board of Managers</i> .....	All the above officers plus the Senior Editor
<i>Board of Editors and Associate Editors</i> .....	[See front cover]
<i>Executive Committee</i> .....	N. R. SMITH (chairman), WALTER RAMBERG, H. S. RAPPLEYE, J. A. STEVENSON, F. M. DEFENDORF
<i>Committee on Membership</i> .....	L. A. SPINDLER (chairman), M. S. ANDERSON, MERRILL BERNARD, R. E. BLACKWELDER, R. C. DUNCAN, G. T. FAUST, I. B. HANSEN, D. B. JONES, DOROTHY NICKERSON, F. A. SMITH, HEINZ SPECHT, ALFRED WEISSLER
<i>Committee on Meetings</i> .....	MARGARET PITTMAN (chairman), NORMAN BEKKEHAHL, W. R. CHAPLINE, D. J. DAVIS, F. B. SCHEETZ, H. W. WELLS
<i>Committee on Monographs:</i>	
To January 1952.....	J. R. SWALLEN (chairman), PAUL H. OEHSE
To January 1953.....	R. W. IMLAY, P. W. OMAN
To January 1954.....	S. F. BLAKE, F. C. KRACEK
<i>Committee on Awards for Scientific Achievement (GEORGE P. WALTON, general chairman):</i>	
For the Biological Sciences.....	G. H. COONS (chairman), J. E. FABER, JR., MYRNA F. JONES, F. W. POOS, J. R. SWALLEN
For the Engineering Sciences.....	R. S. DILL (chairman), ARSHAM AMIRKIAN, J. W. MCBURNEY, FRANK NEUMANN, A. H. SCOTT
For the Physical Sciences.....	G. P. WALTON (chairman), F. S. BRACKETT, G. E. HOLM, C. J. HUMPHREYS, J. H. McMILLEN
For Teaching of Science.....	B. D. VAN EVERA (chairman), R. P. BARNES, F. E. FOX, T. KOPPANYI, M. H. MARTIN, A. T. MCPHERSON
<i>Committee on Grants-in-aid for Research</i> .....	L. E. YOCUM (chairman), M. X. SULLIVAN, H. L. WHITTEMORE
<i>Committee on Policy and Planning:</i>	
To January 1952.....	J. I. HOFFMAN (chairman), M. A. MASON
To January 1953.....	W. A. DAYTON, N. R. SMITH
To January 1954.....	H. B. COLLINS, JR., W. W. RUBEY
<i>Committee on Encouragement of Science Talent:</i>	
To January 1952.....	M. A. MASON (chairman), A. T. MCPHERSON
To January 1953.....	A. H. CLARK, F. L. MOHLER
To January 1954.....	J. M. CALDWELL, W. L. SCHMITT
<i>Representative on Council of A. A. A. S.</i> .....	F. M. SETZLER
<i>Committee of Auditors</i> .....	J. H. MARTIN (chairman), N. F. BRAATEN, W. J. YODEN
<i>Committee of Tellers</i> .....	W. G. BROMBACHER (chairman), A. R. MERZ, LOUISE M. RUSSELL

\* Appointed by Board to fill vacancy.

## CONTENTS

	Page
PHYSICS.—Measure for measure: Some problems and paradoxes of precision. FRANCIS B. SILSBEE.....	213
MATHEMATICS.—A problem in geometric probability. JEROME CORNFIELD and HAROLD W. CHALKLEY.....	226
ETHNOLOGY.—Interesting animal foods, medicines, and omens of the eastern Indians, with comparisons to ancient European practices. LLOYD G. K. CARR.....	229
ICHTHYOLOGY.—A new anchovy of the genus <i>Anchoviella</i> from the Poti and Parnaiba Rivers of Brazil. LEONARD P. SCHULTZ and RUI SIMÕES DE MENEZES.....	235
PROCEEDINGS: THE ACADEMY.....	238

# JOURNAL

OF THE

# WASHINGTON ACADEMY OF SCIENCES

BOARD OF EDITORS

CHARLES DRECHSLER  
PLANT INDUSTRY STATION  
BELTSVILLE, MD.

WILLIAM F. FOSHAG  
U. S. NATIONAL MUSEUM

J. P. E. MORRISON  
U. S. NATIONAL MUSEUM

ASSOCIATE EDITORS

J. C. EWERS  
ANTHROPOLOGY

C. W. SABROSKY  
ENTOMOLOGY

F. A. CHACE, JR.  
BIOLOGY

J. I. HOFFMAN  
CHEMISTRY

T. P. THAYER  
GEOLOGY

MIRIAM L. BOMHARD  
BOTANY

R. K. COOK  
PHYSICS AND MATHEMATICS

PUBLISHED MONTHLY

BY THE

WASHINGTON ACADEMY OF SCIENCES

MOUNT ROYAL & GUILFORD AVES.

BALTIMORE, MARYLAND

Entered as second class matter under the Act of August 24, 1912, at Baltimore, Md.  
Acceptance for mailing at a special rate of postage provided for in the Act of February 28, 1925.  
Authorized February 17, 1949

## Journal of the Washington Academy of Sciences

This JOURNAL, the official organ of the Washington Academy of Sciences, publishes: (1) Short original papers, written or communicated by members of the Academy; (2) proceedings and programs of meetings of the Academy and affiliated societies; (3) notes of events connected with the scientific life of Washington. The JOURNAL is issued monthly. Volumes correspond to calendar years.

*Manuscripts* may be sent to any member of the Board of Editors. It is urgently requested that contributors consult the latest numbers of the JOURNAL and conform their manuscripts to the usage found there as regards arrangement of title, subheads, synonymies, footnotes, tables, bibliography, legends for illustrations, and other matter. Manuscripts should be typewritten, double-spaced, on good paper. Footnotes should be numbered serially in pencil and submitted on a separate sheet. The editors do not assume responsibility for the ideas expressed by the author, nor can they undertake to correct other than obvious minor errors.

*Illustrations* in excess of the equivalent (in cost) of one full-page halftone are to be paid for by the author.

*Proof.*—In order to facilitate prompt publication one proof will generally be sent to authors in or near Washington. It is urged that manuscript be submitted in final form; the editors will exercise due care in seeing that copy is followed.

*Unusual cost* of foreign, mathematical, and tabular material, as well as alterations made in the proof by the author, may be charged to the author.

*Author's Reprints.*—Reprints will be furnished in accordance with the following schedule of prices (approximate):

Copies	4 pp.	8 pp.	12 pp.	16 pp.	20 pp.	Covers
100	\$3.25	\$6.50	\$ 9.75	\$13.00	\$16.25	\$3.00
200	6.50	13.00	19.50	26.00	32.50	6.00
300	9.75	19.50	29.25	39.00	48.75	9.00
400	13.00	26.00	39.00	52.00	65.00	12.00

*Subscriptions* or requests for the purchase of back numbers or volumes of the JOURNAL or the PROCEEDINGS should be sent to HARALD A. REHDER, Custodian and Subscription Manager of Publications, U. S. National Museum, Washington 25, D. C.

*Subscription Rates* for the JOURNAL.—Per year..... \$7.50

Price of back numbers and volumes:	Per Vol.	Per Number
Vol. 1 to vol. 10, incl.—not available.*.....	—	—
Vol. 11 to vol. 15, incl. (21 numbers per vol.).....	\$10.00	\$0.70
Vol. 16 to vol. 22, incl. (21 numbers per vol.).....	8.00	0.60
Vol. 23 to current vol. (12 numbers per vol.).....	7.50	0.90

\* Limited number of complete sets of the JOURNAL (vol. 1 to vol. 40, incl.) available for sale to libraries at \$341.00

MONOGRAPH No. 1, "The Parasitic Cuckoos of Africa," by Herbert Friedmann. \$4.50

PROCEEDINGS, vols. 1-13 (1899-1911) complete.....	\$25.00
Single volumes, unbound.....	2.00
Single numbers.....	.25

*Missing Numbers* will be replaced without charge provided that claim is made to the Treasurer within 30 days after date of following issue.

*Remittances* should be made payable to "Washington Academy of Sciences" and addressed to the Treasurer, H. S. RAPPLEYE, 6712 Fourth Street, N.W., Washington 12, D.C.

*Exchanges.*—The Academy does not exchange its publications for those of other societies.

# JOURNAL OF THE WASHINGTON ACADEMY OF SCIENCES

VOLUME 41

August 1951

No. 8

MATHEMATICS.—*Information theory.*<sup>1</sup> CHESTER H. PAGE, National Bureau of Standards.

Information theory deals with the communication of information without regard to any psychological or semantic "value" assigned to messages. The value measure of a message is ignored from necessity, not from choice. We are forced to assign a numerical measure to a message with reference to a class of messages. For example, a sentence can be considered as a member of a class of messages consisting of all possible sequences of letters and spaces of the given length. Most of these permutations would be meaningless as English text but could be assigned arbitrary code meanings in general. We shall assign a mathematical measure of the information in each that completely disregards any assigned meaning.

We could define the information content of a message in terms of its length, i.e., the number of letters or telegraph symbols it requires for transmission. This turns out to be inappropriate, for most messages contain redundancy and can be uniquely communicated by fewer characters. This suggests using the minimum sufficient character count as a measure of the information. To standardize this idea, let all messages be thought of as coded into binary form, so as to be transmitted by a sequence of dots and dashes, heads and tails, or zeros and ones. The information measure of a message in "bits" (binary digits) will be taken as the number of binary digits absolutely needed to distinguish this particular message from all others of the class considered. One such class might be all 50 character sequences of the 27 symbols of English (26 *letters* and *space*). Let us deal with an example.

For simplicity, reduce the alphabet to 16 characters (including *space*) and consider all possible messages of 35-character length. One member of this class is: THIS IS CERTAINLY A TRIVIAL EXAMPLE. Each of the characters of our short alphabet can conveniently be represented by a unique combination of four binary digits, since there are exactly  $2^4 = 16$  such combinations. This requires  $4 \times 35 = 140$  binary digits to represent the whole message.

The message can, however, be coded for more efficient transmission. Instead of using four binary digits for each character, consider using only three for each of the more frequent characters, at the expense of using five for those less frequent. There is a net gain, as we shall see. Let us tabulate the characters in the order of their frequency. An efficient coding is given in Table 1.

When the message is coded by four digits per letter, the sequence of digits (no spaces!) can be uniquely decoded by dividing it into groups of four, and decoding each group.

TABLE 1

Character	Count	Representation	Total digits
Space	5	000	15
I	5	001	15
A	4	010	12
E	3	011	9
L	3	1000	12
T	3	1001	12
R	2	1010	8
S	2	1011	8
C	1	11000	5
H	1	11001	5
M	1	11010	5
N	1	11011	5
P	1	11100	5
V	1	11101	5
X	1	11110	5
Y	1	11111	5

Average = 3.74 binary digits/letter

131

<sup>1</sup> A lecture delivered before the Philosophical Society of Washington, December 15, 1950.

With our more efficient coding, the message starts as follows: 1001110010011011 . . . . How are the digits to be grouped for decoding? An examination of the representations in Table 1 will show that the decoding is unique, for no shorter group forms the first part of any longer group.

If it is desirable actually to transmit the message in terms of the literal characters rather than binary characters, the sequence of 131 binary digits can be arbitrarily divided into "fours" and each of these groups coded as one of the 16 letters by an arbitrary assignment of the combinations. The 131-digit message can then be transmitted by 33 characters of the original alphabet, instead of the 35 characters needed for straight transmission. At the receiving end these characters are replaced by the 4-digit groups, and the resulting sequence decoded by Table 1.

The digit code that we set up as efficient for our particular message will, of course, be very inefficient for certain other messages. We really wish the coding scheme that is most efficient on the average for the whole class of messages considered. This can be found by using the relative frequencies, or probabilities, of the letters in the whole class of messages, rather than in a particular message. For example, consider the class of messages made up of our 16-letter alphabet, with the individual letters having the probabilities given in Table 2. The total probability is 1. In fact, these percentages are the same as in Table 1, intentionally. Thus if Table 1 represented the relative occurrence of the letters in the whole class of messages considered, the corresponding code would be efficient and would allow the use of 3.74 digits/letter averaged over all messages of the class, weighted by the probabilities of the various possible messages.

With reference to a particular class of messages, we can define the information measure of any particular message as the number of binary digits needed to code the particular message, *using the code that is most efficient for the class as a whole*. The average information per message of this class will be the average number of digits per message, using this code. There is a formula for this average information.

To arrive at the general formula, consider a "perfect" case, one in which each successive binary digit of the code distinguishes between equally likely alternatives. Such is illustrated by a 5-letter alphabet, with the probabilities and representations shown in Table 3.

The average number of digits per character is

$$\frac{1}{2} \cdot 1 + \frac{1}{4} \cdot 2 + \frac{1}{8} \cdot 3 + \frac{1}{16} \cdot 4 + \frac{1}{16} \cdot 4 = 1\frac{7}{8}.$$

Note that this expression is

$$p_1 \log_2 \frac{1}{p_1} + p_2 \log_2 \frac{1}{p_2} + \dots = \sum p_i \log \frac{1}{p_i} = -\sum p_i \log p_i$$

where the logarithms are taken to the base 2. It can be shown that this is a best possible case, and that for any scheme, the average number of digits per character satisfies the relation

$$n \geq -\sum p \log p \equiv H.$$

In our example of Table 2, we have  $n = 3.74$  binary digits/character compared to  $H = 3.71$ . The average information per message in this case is 3.71 bits/character. For any given transmission rate of elements, the information rate can be expressed in bits per second.

Consider the ensemble of all messages composed of these 16 letters with the given

TABLE 2

Character	Probability
Space	0.143
I	0.143
A	0.114
E, L, T	0.086 each
R, S	0.057 each
C, H, M, N, P, V, X, Y	0.0285 each

TABLE 3

Character	Probability	Code
A	$p_1 = \frac{1}{2}$	0
B	$p_2 = \frac{1}{4}$	10
C	$p_3 = \frac{1}{8}$	110
D	$p_4 = \frac{1}{16}$	1110
E	$p_5 = \frac{1}{16}$	1111

relative frequencies; i.e., successive letters independently chosen with the respective probabilities. In a long message of  $N$  characters, the first letter will occur  $p_1N$  times (on the average), the second  $p_2N$  times, etc. The probability of any particular sequence of this length is

$$P = p_1^{p_1N} p_2^{p_2N} \cdots p_{16}^{p_{16}N}$$

which can be simplified by taking logarithms:

$$\begin{aligned} \log P &= p_1N \log p_1 + p_2N \log p_2 \\ &+ \cdots + p_{16}N \log p_{16} \\ &= N \sum p_i \log p_i = -NH. \end{aligned}$$

Since  $H$  was earlier found to be the average information per character, the total information for  $N$  characters is  $I = NH = -\log P = \log 1/P$ . Thus the information in a message is measured by (minus) the logarithm of the probability of sending this particular message of the ensemble.

This result has a certain intuitive justification. If the Archbishop of Canterbury tells you that he believes in God, he conveys little information. You expect him to say this. That is, this "message" is much more probable than its opposite. If, however, he should tell you that he doesn't believe in God, you would attach considerable weight to his statement. It is a very improbable statement, so he must have thought about it carefully before making it!

Let us return to the information formula  $I = -\log P$  and apply it to a very short message of one character. If this is the  $i^{\text{th}}$  character, it carries the information

$$I_i = -\log p_i$$

The average information per character is then the average value of  $I_i$  weighted by the probability of the  $i^{\text{th}}$  character, or

$$\sum p_i I_i = -\sum p_i \log p_i = H$$

as before. It is easily shown that the average information per character ( $H$ ) is maximized by making all  $p_i$  equal, with the result

$$H_{max} = \log (\text{number of characters in alphabet}).$$

It has been said that "one picture is worth a thousand words." This can be roughly analyzed mathematically. Consider

for simplicity all possible 5-letter words made up of 26 characters chosen with equal probability. This is a very crude approximation to English but will serve for the illustration. The average information per letter will be  $H = \log 26 = 4.7$  bits/letter. A thousand words will carry on the average 23,500 bits of information. Now consider the picture as consisting of 10,000 square elements ( $100 \times 100$ ) independently darkened to different shades of gray. How many shadings must be available for the picture to carry our 23,500 bits of information? Each element must carry 2.35 bits, or the logarithm (to the base 2) of the number of available shades must be 2.35. This yields 5.1 shades, a physically absurd answer. We conclude that five shades will carry almost enough information, six will give more than needed.

The general theory of communication is based on the probability concepts we have been discussing. To an engineer a communications "source" might mean a broadcasting station, a phonograph record, or some other physical entity. In the mathematical picture, the source is the ensemble of messages to be handled, that is, a class of messages with assigned probabilities. A communication system is not designed to handle particular messages, but to handle a whole class of messages with the best *average* reliability. The class of messages may be of infinite number, with the probabilities described in terms of a random process for generating successive elements of a message.

With the element probabilities given, and the elements independently chosen, the average information per element,  $H = -\sum p_i \log p_i$ , can be thought of as the average uncertainty of the generating process. If the elements are generated at the rate of  $N$  per second, we can speak of the average uncertainty rate,  $-N \sum p_i \log p_i$ , as the average rate at which information is generated and transmitted. By analogy with statistical mechanics, the average uncertainty is called the "entropy" of the source. Hence we describe a source in terms of its entropy rate. We shall denote this by  $H(x)$ , the  $x$  referring to the source. If the messages generated by the source are received as sent, the rate at which information is received or communicated is obviously the same as the

rate at which it is sent. This can be expressed by the fact that reception has completely removed the uncertainty as to what message was sent. If, on the other hand, messages are corrupted in transit, some information is lost. We can say that there is a residual uncertainty not removed by reception, or that the reduction of uncertainty is less than the original uncertainty. A natural definition of the amount of information received is "the reduction, due to reception, of the original uncertainty of what was sent." Dividing by the time for communication, we obtain the *rate* of communication of information. Letting  $H(x)$  denote the original uncertainty of the source, and  $H_y(x)$  the residual uncertainty, i.e., the uncertainty when the received message ( $y$ ) is known, we have for the rate of communication:

$$R = H(x) - H_y(x).$$

This can also be interpreted as:

(Average rate of sending information) minus  
(Average rate of losing information).

Similarly let  $H(y)$  denote the uncertainty of the corrupted message to be received, and  $H_x(y)$  the irrelevant uncertainty introduced by the source of corruption, the noise on the communication channel. The symbol  $H_x(y)$  indicates the uncertainty of the received message ( $y$ ) when the sent message ( $x$ ) is known. We can consider  $H_x(y)$  as the "false information" in the received message, so that the net rate of receiving (intended) information is:

$$R = H(y) - H_x(y).$$

The two expressions for  $R$  can be combined to yield the following expression for the loss of information, or residual uncertainty of the message:

$$H_y(x) = H(x) + H_x(y) - H(y).$$

The three terms on the right are, respectively: (1) The uncertainty of the source; (2) the uncertainty of the perturbations; and (3) the uncertainty of the result. It can be shown that  $H(x) + H_x(y) \geq H(y)$ , the inequality arising when some of the uncertainty of the changes duplicates some of the original uncertainty. Hence the loss

of information equals the loss of uncertainty or lack of additivity in the mixing process. This effect is similar to the increase of entropy occurring in the mixing of isotopes.

For a given communication channel, that is, given corruption effects  $H_x(y)$ , the statistics of the source can be adjusted to maximize the rate of communication. This is the statistical analog of impedance matching. The maximum rate so obtained is called the *capacity* of the channel. It was shown by Claude Shannon, of the Bell Telephone Laboratories, that any source generating information at a rate  $R \leq C$  can be so encoded as to be communicated over any channel of capacity  $C$  with an arbitrarily small error. A special example will serve to illustrate this remarkable theorem.

Consider a channel handling binary digits and making not more than one error per block of seven digits. We shall see how to encode a message so as to transmit it over this channel with absolutely no errors.

Associated with each block of seven digits are eight error possibilities: no error, and seven possible error locations. These eight cases can be identified by three binary digits. Let the case of no error be arbitrarily called an error in position zero. Then the possible error positions can be identified by the following code:

Error Position	Identification
0	000
1	001
2	010
3	011
4	100
5	101
6	110
7	111

The last four error positions are distinguished by an initial 1 in the code. A scheme for automatically generating a 1 in case the error is in one of these positions would eliminate half the possibilities. Similarly, automatic schemes for determining the other two binary digits would result in complete location of the error. Since the information is being transmitted by binary characters, location of the error allows correction of the error, since there are only two different characters. Such a scheme has been devised. Let the seven digits of the



message block be denoted by  $x_1, x_2, \dots, x_7$ . If these digits are such that

$$x_4 + x_5 + x_6 + x_7 \equiv 0 \pmod{2},$$

that is, if there is an even number of 1's among these four, then changing any one of these will make the sum  $\equiv 1 \pmod{2}$ . Thus if the error occurs in position 4, 5, 6, or 7, the distinguishing 1 will be generated. Similarly, the second digit of the error identification can be found if the transmitted digits  $x_2, x_3, x_6, x_7$  are so related that

$$x_2 + x_3 + x_6 + x_7 \equiv 0 \pmod{2}.$$

The last digit is determined by initially specifying

$$x_1 + x_3 + x_5 + x_7 \equiv 0 \pmod{2}.$$

In these three conditions, the digits  $x_1, x_2, x_4$  appear singly and separately, so these three digits can be chosen to satisfy the conditions, no matter what  $x_3, x_5, x_6$ , and  $x_7$  may be. The latter four can be chosen arbitrarily, i.e., used to carry information, and the other three adjusted to meet the conditions.

For example, suppose we wish to send the message 1011. Then  $x_3 = 1, x_5 = 0, x_6 = 1, x_7 = 1$ , and we must make  $x_1 = 0, x_2 = 1, x_4 = 0$  to satisfy the three conditions. The sequence transmitted is 0110011. Now suppose the fifth digit is changed in transmission; we receive 0110111. What was sent? Testing by the first condition, we find  $x_4 + x_5 + x_6 + x_7 \equiv 1 \pmod{2}$ , i.e., an odd number of ones among the last four digits. The first digit of the error identification is therefore 1. The second condition gives

$$x_2 + x_3 + x_6 + x_7 = 1 + 1 + 1 + 1 \equiv 0 \pmod{2},$$

and the third one gives

$$x_1 + x_3 + x_5 + x_7 = 0 + 1 + 1 + 1 \equiv 1 \pmod{2}.$$

The error is therefore identified by 101, which refers to position five. We change the

fifth digit and have the original message.

In practical communication, we are more concerned with information represented by continuous functions than by discrete sequences. Telephony utilizes a voltage wave, for example, and direct speech an acoustic pressure wave. Unfortunately the statistical mathematics dealing with ensembles of random functions is very complex. I can do no more here than to present briefly some of the results in this field.

The characteristics of an ensemble of continuous functions are described partly by a statistical term, and partly by the power spectrum, or distribution of the power versus frequency by Fourier analysis. It has been found that the worst kind of noise has a so-called Gaussian statistical distribution, and that the best source for combatting such noise has also a Gaussian distribution. My remarks will therefore be confined to this case. Analysis shows that the best power spectrum for the source, i.e., the best distribution versus frequency of the total source power, is such that the received signals have a "flat" spectrum. That is, the received power should be uniformly distributed over the frequency range used. This means that the source spectrum should be complementary to the noise spectrum, we try to send more message where there is less noise, and vice versa. This result agrees with the familiar pre-emphasis techniques of frequency modulation and some recording processes. With this complementarity satisfied, we achieve a channel capacity that can be expressed as

$$C = W \log \left( 1 + \frac{P}{N} \right)$$

where  $W$  is the width of the frequency band used,  $P$  is the total signal power in this band, and  $N$  the noise power. This fundamental relation shows how bandwidth may be traded for power, or vice versa, and has had engineering applications.

ETHNOLOGY.—*Utilization of animals and plants by the Micmac Indians of New Brunswick.*<sup>1</sup> FRANK G. SPECK,<sup>2</sup> University of Pennsylvania, and RALPH W. DEXTER, Kent State University. (Communicated by John C. Ewers.)

In the summer of 1949 the writers went in search of further information on the utilization of animals and plants by American Indians, continuing the studies already published (Speck and Dexter, 1946, 1948). We were fortunate in finding near Limington, Maine, Mr. and Mrs. Louis Francis, who had come from the Micmac band at Richibucto, New Brunswick. They are familiar with the hunting and fishing activities in their native region from their own experience and through contacts with older people there, and to them we are greatly indebted for their unstinted cooperation in this ethnological study. We were able to learn from them the principal animals and plants that have been utilized, especially those used for food. Most of such practices have been handed down from ancient days. This investigation centered around food and its procurement, but other uses were brought out incidentally, particularly the multiple uses of certain food organisms, and such information is included in this report. Information from our informants has been correlated with the archeological, ethnological, and biological publications on the region. Medical use was not investigated, since that is a special study in itself and some material has already been published on that subject (Hagar, 1896; Speck, 1917; Wallis, 1922; Stone, 1932).

The culture of these Northeastern Indians has always tied them close to nature, since originally they depended almost entirely upon the harvest of natural resources. Even

<sup>1</sup> Acknowledgment is made to the Faculty Research Fund (Grant no. 594), University of Pennsylvania, for financial assistance in this project.

<sup>2</sup> In the course of preparing this study for publication, Dr. Speck passed away on February 6, 1950. Through the kindness and efforts of Mrs. Frank G. Speck and John Witthoft, Pennsylvania Historical Commission, Harrisburg, it was possible for the junior author to complete the manuscript very nearly as it was originally planned. Mr. Witthoft is responsible for the transcription of the phonetic forms from Dr. Speck's field notes, and any errors present are due to misinterpretations of his handwriting, which suffered with his failing health. Valuable suggestions were made by Mr. Witthoft and by Ernest S. Dodge and Wendell S. Hadlock, of the Peabody Museum, Salem, Mass., all of whom read the manuscript critically.

today this relationship persists. Modern economic life still consists largely of fishing, trapping, hunting and serving as hunting guides, lumbering, and splint-basket weaving. Agriculture has developed extensively only within historic time. Undoubtedly two important reasons why agriculture did not develop to a high degree were the poor soil and the short growing season which imposed limitations (Hadlock, 1947a). This is a good example of the way in which environment determines economic development. Wissler (1926) has pointed out that "students of culture are well agreed that the objective forms taken by aboriginal tribal cultures are determined by the features of the environment to which native life has been adjusted." Sears (1932), writing about the environment of the Northeast in general, has explained that "the vigorous growth of forest, abundance of fish and game, rigorous winters, and tendency of much of the land when cleared to become acid were in no sense, at any time, a stimulus to agriculture." Native animal life, on the other hand, permeated the entire life of the Micmac culture. Their rich folklore, of which much has been recorded, is largely concerned with hunting and fishing activities, or involves animals of the chase, and their magico-religious beliefs centered around animal spirits. Art was expressed chiefly on the skins, bones, and teeth of animals. A significant portion of their social organization was concerned with the family hunting territory system. Their housing and clothing at one time were made largely from animal skins. Some of their native medicines were derived from animal products. Their food consisted chiefly of the spoils of fishing, hunting, and trapping pursuits of the men. Such activities took place along the seashore, in the tidal inlets and saltwater ponds, rivers, marshes, bottomland swamps, and in the forests of mixed conifers and hardwoods and their glades. This animal diet was supplemented by the gathering of fruits, berries, nuts, seeds, roots, and similar plant products by the women. Little, if any, cultivation was practiced, al-

though in protohistoric times planting of maize, squash, and beans was carried out.

Let us enumerate, then, the principal wild animals and plants which have been utilized by the Micmac for food with special reference to the coastal band at Richibucto. Admittedly, a complete study can not be made with the information from two informants, but certainly the most important natural food products would come to the attention of those who have lived in the community under investigation. Our own notes have been supplemented with gleanings from published accounts. Originally it was planned to prepare a table of organisms known to be used by the Micmac with a column for the native names used by this group of Indians. This was not completed before the death of Dr. Speck. John Witthoft has since transcribed the phonetics recorded by Dr. Speck in the field for use by the writer. We discovered that a complete list of names was not made, as Dr. Speck undoubtedly depended upon memory for those Indian words well known to him. For this reason, Table 1 was not completed as planned, but in each case where the Indian name was recorded, it is given in the text. This investigation was approached through a synthesis of the special interests of the collaborators. The ethnological phases were handled by the senior author, who often conversed with the informants in their native dialect, while the biological and ecological phases were handled by the junior author. A similar report on the Malecite Indians of the St. John River Valley of New Brunswick, investigated at the same time, will be published at a later date.

#### THE COASTAL MICMAC INDIANS OF RICHIBUCTO

The Micmac Indians of coastal Nova Scotia and eastern New Brunswick have long attracted the attention of anthropologists. The prehistoric culture of these northeastern shore dwellers, so far as it is known, has been described through the archeological papers of Jones (1864), Patterson (1889), Piers (1895, 1912), and Smith and Wintenberg (1929). Ethnological descriptions have been given by the early travelers, visitors, and clergymen who lived among the Micmac, particularly in the writings of Maillard

(1758), Rand (1850), Elder (1871), Hagar (1895), Chamberlain (1904), Denys (translated by Ganong, 1908), Le Clercq (1910), and Lescarbot (translated and reprinted, 1928). Modern scientific studies have continued to chronicle the culture of the survivors of these neolithic hunting and fishing people in such publications as those of Speck (1922), Flannery (1939, 1946) and Cooper (1946). Micmac folklore has been recorded by Leland (1884), Rand (1894), Alger (1897), Prince (1906), Speck (1915a), Parsons (1925), and Michelson (1925).

The Micmac Indians long depended upon marine resources for food, especially during the summer months. Probably the great majority of this tribe lived on or near the coast; Le Clercq (1910) pointed out that the summer months were spent at the seashore where fish and meat were dried and smoked for winter use. Those living at Richibucto at the mouth of the Richibucto River obtained much of their subsistence from the marine resources of Big Cove. Marine life played a very important part in the economy of these seashore dwellers. The mollusks, particularly, were utilized. Ganong (1889) many years ago wrote that "the most valuable to man by far, in all the groups of invertebrates, is that of the Mollusca. In all parts of the world, savages and civilized men have utilized its members." In his monograph Ganong gives a complete list of mollusks that have been used by the inhabitants of Acadia. Further information is available in the reports on shell heaps which have been excavated in the region. These give mute evidence that the shelled animals especially were harvested by the Micmac over a long period of time, and that they formed the great bulk of the diet of these Indians during the warm months of the year. In the mud flats during periods of low water the soft-shell clam (*es*) is easily available. Its tenderness and flavor have made it a favorite as a food mollusk by all groups of mankind living within its range. Shells of this species make up a large percentage of the shell mounds.

The razor clam was also dug from the mud and sand flats although not in such abundance as the soft-shell clam. In mussel beds over the tidal sediments and on rocky shores the blue mussel grows in abundance. Lescarbot, writing in 1609, is quoted by Ganong saying, "The Micmac have a superstition, not to wish to eat mussels (*M*,

*edulis*), yet they cannot give a reason for it—nevertheless, in our company, seeing us eat them, they did likewise." The number of blue mussels in kitchen middens, however, would indicate that at one time it was a popular item of food. Attached to these mussel beds, and on the rocks of the lower shore line, live the boat shells or slipper shells, which have long been considered a delicacy by the North American aborigines of the Atlantic coast. Along the exposed shore at times of perigee tides, the sea clams or hen clams were gathered. These were boiled and made into a stew. The shells have been used in recent times for decoration about homes and gardens. In the shallow waters of the inlets and salt-water ponds the quahog has been collected in abundance. Besides being an important item of food, the shells were used as a source of purple wampum. Piers (1912) quoted Lescarbot making the claim that wampum was obtained by barter with the New England Indians. How much actual manufacture of wampum beads (Kwayo'psu) was carried out by the Micmac is not known although the quahog shells were available to them. Today, however, the quahog is only rarely found between Cape Cod and the Gulf of St. Lawrence. Wampum among the Micmac was used for ornaments and ceremonies rather than money. Denys (1908) mentions that the wampum beads were originally strung on tendon removed from the spine of a moose. A Micmac wampum belt is described and illustrated in Bulletin 4 of the Free Museum of Science and Art of the University of Pennsylvania (author not given). This belt is an example of the use of wampum for symbolic purposes and is believed to commemorate the friendly alliance of two Christian communities among the Indians. This type is sometimes called a "missionary belt."

Another valuable shellfish is the oyster (*ma'nd-ama(-x pl.)*). Again, oysters are no longer found in any significant abundance between Cape Cod and the shores of eastern New Brunswick on the Gulf of St. Lawrence, although they are abundant in many prehistoric shell heaps in the intermediary area. With the coastal Micmac, however, this bivalve mollusk was nearly as important as it was to the Wampanoag of southern Massachusetts. Quantities of oyster shells have been found in refuse heaps in both places. Ganong (1889) places this mollusk first in importance although shell heap studies in Micmac territory do not always indicate this to be true. Often,

shells of the soft-shell clam are far more numerous. Ganong probably based his appraisal on the use of the oyster over a long period of time, with special reference to use in recent times. Besides being an important item of food, oyster shells were used to polish wood for their bows, according to Denys (1908). Scallops are listed by Ganong as the third most important group of mollusks utilized in the New Brunswick area. The horse mussel and two snails, the sand-collar snail and the English whelk, were also used according to the findings in refuse heaps, although Mr. Francis did not know of their being used in recent times. Shellfish at one time were a very important part in the economy of the coastal Micmac. They were used for food, bait, ornaments, and for temper in the manufacture of pottery. Pottery was often made by these people, but their efforts were very crude. Sea shells were powdered for use as temper in some of the pottery they did make. Piers (1895) has described the use of seashells as ornaments fastened to the ears, neck, bodies, arms, and legs of the Indians.

Shells of all species mentioned above have been found in refuse heaps excavated in Micmac territory except the razor clam. Mr. Francis did not know of its use, but Cooney (1832) and Denys (1908) listed it among others eaten by these people. Shells of several small species of snails (e.g., *Thais lapillus* and *Urosalpinx cinereus*) have also been identified, but probably these were gathered incidentally, especially the latter species which is the oyster drill, a predatory snail, commonly found feeding on the oyster.

Fowler (1871) has called attention to the fact that many shell heaps have been washed out by the sea. Undoubtedly many such deposits have been destroyed in the past. Smith and Wintenberg (1929) found many shells that had been used for food but did not discover any implements made from the shells nor did they find any wampum. They found three shells of *Cepaea hortensis*, a land snail (*mi'kteick*). This species has been thought by some zoologists to be a European introduction. Its discovery in Indian shell heaps is, therefore, of notable interest. Its use by the Indians, if any, is questionable. Also, the snails may have burrowed or been carried underground by animals in recent times.

Squids were at one time commonly eaten. Denys (1908) described the method of capturing them as follows. During a rising tide (*we'tkaba'x*) a bonfire was built on the shore. Squid, attracted

by the light, swam into shore and were stranded on the beach as the tide went down. Other invertebrate foods from the sea (*ak'ta'ʔan*) include the lobster, the rock crab (*indjindja'ges*), and shrimp (*tca'gadji'tc*). The lobster was captured with a spear. According to Denys (1908) lobster claws were used as pipes. The crabs and shrimps were used as bait as well as food. Lescarbot, writing in 1606, and Cooney (1832) both list sea urchins and Cooney also mentions starfish among food items, but no other evidence is available on the use of these echinoderms by the Micmac. No evidence was uncovered from any source that the horseshoe crab had any part in the economy of these maritime people although it is known to have been used along the New England coast for many purposes.

Marine vertebrate animals were also of great importance. Seals (*wa'spux*) were hunted for food, hides, and oil. The oil was used in cooking, for fuel, and to grease the hair. Seal oil was a delicacy at their feasts. Seal skins spread over needles of the fir tree were used for bedding. While the walrus is now extirpated in this region, it was hunted in former times as indicated by tusks found in the refuse heaps. The ivory was used in the manufacture of such objects as harpoon points and the dice used in the game known as "Indian Dice," according to Piers (1912). It is believed that the Micmac traded ivory to the Penobscot tribe in Maine. Whales (*po'dap*) and porpoises (*mospet'c*) were obtained whenever found stranded on the shore or were harpooned from drift boats. In addition to the use of the oil and meat, the ribs were used for bark peelers and wedges (Smith and Wintemberg 1929). Sea turtles (*miktci'kc*) were similarly captured and utilized. The marine fish were of special importance and have continued so to the present day. Smelt (*ga'xpesaw*) is the first to appear in the spring followed by the herring (Denys 1908). Smelt were captured by the placing of hurdles across a brook to trap the fish in the head waters (Lescarbot 1928). According to Mr. Francis they were also taken on a fishing line. The herring and their young, known as sardines, were eaten in large quantities. They were also used for fertilizer. Mackerel (*hámānā'n*), capelin, and a species known to Mr. Francis as the salt-water sunfish (*nago'sit nāme'tc*) (which the writers do not recognize), were similarly obtained for use. Fish of the sea bottom which have been utilized are the flounders (*ana'gwete*), halibut (*psa'nak<sup>w</sup>*), cod

(*pe'dju*), haddock, Norway haddock (now known as rose fish or redfish), cunner, sculpins (*mæ'n-dowe nēme'tc*), skates (*tekānā'lowi'tc*), and dogfish (*α'lāmutc nāme'tc*). These demersal fish were obtained by spearing in shallow water as well as by nets and hook and lines. Oil from the liver of codfish and the flesh of redfish were of economic importance to the Indians long before these became of commercial importance to white man. Jones (1864) suggested that the opercular spines of redfish found in shell heaps were used as an awl for punching holes. Mr. Francis does not know of the dogfish or sculpin being used for food in recent times.

The Micmac employed many devices for obtaining aquatic resources. These included spears (*ni'gok*), harpoons with points made from bone or walrus ivory, hook and line (*m'ki'gana'tk<sup>c</sup>*) made from hemp with fishhooks (*m'ki'gan*) of bone, fish nets (*ābi*) with stone sinkers, dip nets (*n'pha'ni-ganabi*), and fish weirs with a bag net. Fish pounds (*hāluda'ʔan*) were made to trap the ocean fish in an enclosed basin where they could more easily be captured.

Entering the rivers are a number of anadromous fishes that were sought by the Indians. Included were the sturgeon, Atlantic salmon (*nigo'k*), shad (*apsa'mu*), striped bass (*elta'Xte*), white perch (*wa'pet dja'xtedji'tc*), tomcod, and the sea lamprey. Most of these were speared at night with the aid of a birch-bark torch. This was particularly true of the sturgeon and salmon. There is only one species of salmon on the Atlantic coast. Our informant spoke of three different types, the "black," "bright," and "hooked-bill salmon." It is clear that what he believed to be different species were merely variations in color and a difference in sex. The male Atlantic salmon has a protruding lower jaw which has given the name hooked-bill salmon to this sex. Salmon were pursued particularly in June. The method of torch fishing is vividly described in the words of Dr. Speck as follows:

"Of equal importance in the taking of fish is a method known as 'torch fishing' in use among peoples throughout the forest area of the entire Northeast. Torch fishing (*Seksi'gwe'*) is resorted to at night by two men who man a hunting canoe (*kwi'dan*) which is driven to the base of waterfalls where in the North salmon congregate in the spring-run ready to ascend to their spawning beds. The canoe is managed by the steersman whose job is to direct the boat where the man in

the bow tells him. The bowman is the actor in this night drama of food getting and sport—for sport it also distinctly is in the minds of the Northern Indians. The bowman is armed with a double bracketed fish spear or leister. With this type of spear he is able to impale large fish which swim within range of his light. Now let us examine this light which gives the distinct character to this method of taking fish. It consists of a bundle of folded birch bark several feet in length and some inches in thickness tied firmly with splints of basswood and fastened into the cleft of a pole fastened in the bow of the canoe. The torch pole is tilted over the water. When ignited this torch, or flambeau, illuminates a wide space at the side of and at the head of the canoe in which swimming fish can be seen as they rise to the surface apparently attracted by the flare. Then comes the thrust, and the impaled fish is lifted out of the water passed toward the stern and released from the harpoon by the steersman where its flopping carcass is deposited in the bottom of the craft. When the salmon run is on a little flotilla of fishing canoes may be afloat in the pool engaged in this combined sport and food procurement."

Besides the true anadromous fishes, the salt-water trout (me'gwe adogwa'su) enters the mouth of rivers for the winter and spring seasons after the breeding season is over, and there they are captured by the Indians. Salmon, shad, herring, and gaspereau (the fresh-water herring) were formerly smoked for preservation, using the hardwoods for fuel. Very little of this is done today although fish are frequently salted. According to Denys (1908) the fishing canoes were made of slats of cedar covered with birch bark. The bark was sewed with roots of black spruce, and seams were sealed with spruce gum. Paddles were made of beech wood and a sail made from the skin of a moose calf. The fish were brought to shore and dried on gravel beaches and flakes. In winter time hook-and-line fishing was accomplished through holes cut in the ice.

In the fresh waters a number of aquatic vertebrates were also obtained. Eels (ga'dan) were pursued at night with spear and hook and line. Wallis (1922) mentions the use of the skin of this catadromous fish as a bandage. Whitefish and suckers (kam'kwet tu'pkwani) were also caught. Our informant never heard of the use of the bow (ha'bi-) and arrow (matc?'teli'gan) in catching fish such as are commonly employed by the Ca-

tawba Indians of South Carolina. In the ponds, frogs (Xato'walan tcko'ltck = bullfrog; itcko'ltck = green frog) and toads of the larger species were gathered for eating the legs. Turtles (mikt-ci'te), especially the snapping turtles, and their eggs were collected for food. The shell of the snapping turtle served as a container. Wallis (ibid.) lists turtle fat as a lubricant in the treatment of rheumatism. Reptile lore of the Northeastern aborigines has been treated in an earlier paper (Speck 1923)

The fresh-water clams were not eaten to the best knowledge of our informants. Neither is there any evidence from excavations that such ever played a part in the diet of coastal Indians. As the writers found to be the case with the Wampanoags of Massachusetts, the less desirable fresh-water clams did not attract the Indians because of the abundance and ease of obtaining salt-water shellfish.

Waterfowl, especially the ducks and geese (si'nam = Canada goose; mo?alewi'tc = brant), and their eggs were taken for food. Other birds, listed by our informants from which the eggs were gathered, are the gulls, loons, shorebirds, and the great blue heron. Denys (1908) claimed that the Micmac ate all large birds and their eggs except the cormorant, and he added further that the feathers from the Canada goose were used in the making of robes. Water birds were hunted at night in a canoe with a birch-bark torch much as described for salmon fishing. Needles and awls were manufactured from the bones of birds, and bird feathers were used for ornamentation, such as the headdresses made of a few eagle feathers.

The aquatic mammals were of especial importance. Muskrat (ki'wesu), otter (gi'unik), and beaver were trapped for food and hides. Robes were made from the fur of these three especially. Some were painted with a red dye extracted from the roots of small bedstraw (*Galium tinctorium*) (Denys 1908). Speck and Eiseley (1939) and Cooper (1939) described the conservation of beaver by the Northeastern Indians. By proper management they maintained a rather stable population of beaver at selected sites.

In the late fall and winter seasons hunting and trapping pursuits claimed the attention of the Micmac. At these times the game was in the best condition, and the pestiferous insects so severe in the summer season are not present. The Indians went inland for hunting at this time

(Piers, 1912). The physical and biological environment of the mixed hardwood and coniferous forests of the Northeast is succinctly summarized by Byers (1946), who pointed out that nearly all animal life available was taken in the hunting and trapping activities of the Northeastern area in early times. Denys (1908) has related that hunting was the chief occupation of men and the main source of food in the winter time, and at the funeral of a hunter mourners recited the animals which the hunter had killed in the chase. The upland hunting economy was based upon the family hunting ground system and an understanding of ecological principles of game populations, their relationship to the environment, and the balance of nature (Speck, 1915b; Speck and Eiseley, 1939; Cooper, 1939; and Hollowell, 1949). Authorities agree that this system is pre-Columbian in origin. At one time the woodland caribou was of special importance in the life of the Northeast Indian. It was an important source of both food and hides. According to Byers (1946), the stomach contents of the caribou as well as the flesh were eaten by the Indians. Dice used in their games were made from the bone of caribou (Hagar, 1895); scrapers and knives were prepared from the ribs (Elder, 1871). The caribou was hunted on snowshoes made with frames of ash or beech, corded with moose skin or animal intestines, and bow and arrows made from rock maple. Trumpets for calling the animals were made of birch bark. Dogs were used in hunting in which the object was to drive the caribou into deep snow so that the Indians could easily capture and kill them. Ward (1878) has described in detail this method of caribou hunting. The caribou is now extirpated from the New Brunswick region, but is still remembered by the older Indians. Next to the caribou, moose was the most important big game animal. The tongue and nose of the moose were considered a special delicacy for food. Grease was boiled out of the bones. The hides were used in the manufacturing of moccasins. According to Denys (1908) clothing, stockings, shoes, and bed coverings were made from moose hide, and the bones were made into pipes. Le Clercq (1910) mentions that the dew claws were used for rattles. Smith and Wintenberg (1929) described chisels made from the antlers, pendants from the incisor teeth, and perforated toe bones that were probably used in games. The skins of these large animals were used for tent coverings as well as for clothing. Some of

the meat was dried and stored and the intestines were stuffed. The meat was cooked in the trough of a log filled with water into which hot stones were dropped for heating. Apparently all parts of these large game animals were used for something.

Some believe that the white-tailed deer or Virginia deer (li'ntuk) was not present in New Brunswick when white men arrived, but after the woodland caribou was decimated, the deer came into this area (Byers, 1946). However, Smith and Wintenberg reported deer bones (possibly caribou mistaken for deer?) in shell heaps of Nova Scotia which had been adapted by the Indians for use as awls. In any case, this large game animal has taken the place of the caribou in modern times. The black bear (mu'win) was another one of the large forest animals pursued by the prehistoric Micmac for both food and hides. Pendants were made from bear's teeth. The bear was one of the most popular animals mentioned in the folklore of these people. Hagar (1896) stated that this animal was believed to possess the greatest magical powers of all the animals known to the Indians.

Of the smaller forest game, the porcupine (ma'dawes) was one of the most useful from the point of view of the variety of its contributions to the economy of these Indians. The flesh was eaten and the quills were used for decoration on birch-bark vessels and on clothing prepared from animal skins. The quills were dyed red with a dye obtained from the roots of small bedstraw. Pottery has been found (Smith and Wintenberg, 1929) which is believed to be impressed with woven porcupine quills. Wallis (1922) claims that urine from the porcupine bladder was used in the treatment of hearing defects, and the fatty oil of this animal was used as a physic for newborn children. The importance of this animal easily explains why the Malecite referred to the Micmac as the "Porcupine Indians" (Matu-es-wi skitchi-nu-uk), according to the statement of Piers (1912). Other important upland game animals were the raccoon (amatei'gwite), snowshoe rabbit (wabus), woodchuck (mo'namkwete), and the red and grey squirrels (a'dudwete), all of which were used for food and fur. The skunk (abiktciu), red fox, pine marten, fisher (ap'amp'k), mink (di'a'ge'ute), weasel (sk'us), wolf (ba'Xtazam), wolverine (ki'gwadju), and lynx were hunted for their pelts. Grease from many of these was also used in medicine (pi'sun); awls were

made from the ulna of the red fox and pendants from the teeth of the wolf (Smith and Wintenberg, 1929). Our informant spoke of five kinds of foxes, but they are all color phases of the red fox. According to Chamberlain (1884), the wolf was common between 1840-60, but it has since disappeared, and the wolverine was not found after the middle of the nineteenth century. In recent times these large carnivores, when they were extant, were killed largely as vermin. Perhaps the most important of the upland game birds was the Canada ruffed grouse (*pəla'wətc*). Our informants were not familiar with the spruce grouse. In modern times the ring-necked pheasant has been introduced as it has been elsewhere in North America as a game bird. Denys (1908) included the crow and the robin in his listing of edible birds. The great auk and the passenger pigeon were also hunted before they became extinct.

Hunting and trapping devices used by the Micmac are as follows: Bow and arrow, with the arrowhead of stone or bone; snare traps (*nabot'aʔan*); the spring pole (*haboawegan*); dead falls (*ni'si'aXlə'Xtegan*); wooden clubs; stone axes; and knives made from the teeth of beaver. Snowshoes were used in winter hunting. The snowshoe cording frequently was made of the intestines of animals as were the strings on the bows. Dogs were regularly used in hunting. All observers seem to agree that all these primitive neolithic people of Northeastern North America probably utilized, especially for food, almost any animal that could be captured and that all edible portions were consumed, even the marrow of bones obtained by cracking open the large bones. Flannery (1946) claims that even cannibalism was practiced at one time by the eating of captives taken in war. In spite of their variety of diet and their practice of what we regard as conservation measures (MacLeod, 1936; Speck, 1938), there were times of famine among these hunting and fishing people.

Animal remains found in Micmac refuse heaps at various times and at various horizons include the following:

Moose	Raccoon	Rabbit	Dog	Fisher
Caribou	Porcupine	Seal	Wolf	Deer?
Bear	Squirrel	Whale	Red fox	
Muskrat	Woodchuck	Walrus	Lynx	

Also, the bones of many unidentified fish and birds have been found. Animal bones, however, are not nearly as common as the shells. Smith

and Wintenberg (1929) believed that the relatively small number of fish bones was explained by the late development of fishing. Loomis and Young (1912), on the other hand, found fish bones in heaps on the Maine coast at the bottom. This was interpreted as a case of the Indians coming to the shore originally for fish, and later acquired the habit of eating shellfish. However, Witthoft (personal communication) has pointed out that fish do not leave such bulky waste as shellfish do, and actually fish bones occur throughout the Maine heaps.

Plant resources for the most part were secondary in importance, although plant products were of particular value in the diet during certain seasons. Halliday (1937) and Morison (1938) have outlined the forest types and enumerated the tree species of New Brunswick. The latter also gives a very good general description of the topography, geology, and climate of the region as well as the forests. From the standpoint of food, the sugar maple or rock maple tree is of greatest interest. Maplesugar (*sna'wi·si·smo'gan*) and maple syrup (*sna'wi·mlas·is*) were prepared from this tree dating back to prehistoric times. Denys (1908) explains that the sap was drawn off through porcupine quills. Henshaw (1890) has traced the early history of maple sugar manufacture by the American Indians. It has already been pointed out that wood from this tree was used in the manufacture of bows, polished with oyster and others shells.

From the standpoint of general utility, the canoe birch was undoubtedly of greatest significance. The wood was used in the manufacture of snowshoes and toboggans (Cooper, 1946) and the bark (*ma'skwes*) for the manufacture of canoes, house coverings, boxes, baskets, containers of various kinds, dishes, cooking utensils, and even coffins. It has been mentioned above that the bark was sewed with the roots of black spruce and often ornamented with porcupine quills. It will also be remembered that birch bark was used as a torch in night fishing and a birch-bark trumpet used for calling caribou and moose. Arrow shafts and canoe slats often came from white cedar. Black ash, more commonly called brown ash by the Indians, has been the most common source for basket splints in the manufacture of basketware. Red maple has similarly been used. In modern times sweetgrass has been introduced for the weaving of baskets and mats to take the place of rushes which were for-



merly used. White ash was used in the manufacture of axe and knife handles. The bark of alder, elm, and hemlock was used in the preparation of dyes. Stone (1932) described the chewing of alder bark for the treatment of wounds, fractures, and dislocations. Wood from the conifers was used for kindling and the hardwoods for fuel. Cooper (1946) stated that the wood of birch and conifers was preferred for cooking. Beds were made from the boughs of spruce and fir covered over with animal skins. The leaves of willow trees served as tobacco (*tama'wi*), and pipe stems were manufactured from willow twigs (Denys, 1908). The bark of certain trees was utilized in the making of drums, and inner bark of some trees (probably the pectin-rich bark of hemlock and pines) served as a famine food (Lescarbot 1928) and as a cure for scurvy. Hadlock (1947b) reported on woven mats which were probably made from bark of either red cedar (juniper) or arbor vitae (white cedar).

Wild fruits and berries known to have been gathered during the late summer and early fall

seasons were as follows:

Blueberry	Elderberry	Crab apple
Huckleberry	Cranberry	Wild cherry
Strawberry	Partridgeberry	Choke cherry
Raspberry	Bearberry	
Blackberry	Black and red currants (gooseberries)	

Acorns (*siste'gawet*) and nuts were gathered from hazelnut, butternut, beech (beech nuts = *swo'mussip'han*), and oak trees. Lescarbot (1928) mentions the gathering of peas along the sea-shore. Beverages were prepared from partridgeberries, labrador tea, muskrat root, sarsaparilla, and the bark from hemlock, white pine, black spruce, white spruce, balsam fir, rock maple, moosewood, and wild-cherry trees. Most of these beverages or teas were employed as medicines. Tubers of the wild potato (*ta'b'adank*), called artichokes by the Indians, were dug up for food. The dandelion (*si-smo'ni ma'tekewe*), since its introduction from Europe, has been gathered for greens just as it has been used by white man for the same purpose. The roots of gold thread and muskrat root or sweet flag (*ki-we'swapsk<sup>c</sup>*) were chewed for their medicinal value.

TABLE 1.—ANIMALS AND PLANTS UTILIZED BY THE MICMAC INDIANS, CHIEFLY FOR FOOD OR FOOD PROCUREMENT

Scientific Classification	English Name	Scientific Classification	English Name
<b>PELECYPODA:</b>		<b>PISCES (Continued):</b>	
<i>Ostrea virginica</i>	Oyster	<i>Mallotus villosus</i>	Capelin
<i>Pecten grandis</i>	Deep-sea scallop; giant scallop	<i>Osmerus mordax</i>	Smelt
<i>Pecten islandicus</i>	Scallop	<i>Scomber scombrus</i>	Mackerel
<i>Modiolus modiolus</i>	Horse mussel	<i>Roccus saxatilis</i>	Striped bass
<i>Mytilus edulis</i>	Blue mussel; edible mussel	—?	Salt-water sunfish
<i>Spisula solidissima</i>	Sea clam; hen clam	<i>Morone americana</i>	White perch; sea perch
<i>Mercenaria mercenaria</i>	Quahog; hard-shell clam	<i>Sebastes marinus</i>	Redfish; Norway haddock
<i>Ensis directus</i>	Razor clam	<i>Tautoglabrus adspersus</i>	Cunner
<i>Mya arenaria</i>	Soft-shell clam; long-neck clam	Cottidae	Sculpins
<b>GASTROPODA:</b>		<i>Microgadus tomcod</i>	Tomcod
<i>Cepaea hortensis</i>		<i>Gadus morhua</i>	Cod
<i>Polinices heros</i>	Sand-collar snail	<i>Melanogrammus aeglefinus</i>	Haddock
<i>Crepidula fornicata</i>	Boat shell; slipper shell	<i>Hippoglossus hippoglossus</i>	Halibut
<i>Buccinum undatum</i>	English whelk	<i>Lophopsetta aquosa</i>	Sand flounder
<b>CEPHALOPODA</b>	Squid	<i>Pseudopleuronectes americanus</i>	Winter flounder
<b>ECHINODERMATA:</b>		Catostomidae	Suckers
Asteroidea	Starfish	<i>Perca flavescens</i>	Yellow perch
Echinoidea	Sea-urchins	<b>AMPHIBIA:</b>	
<b>CRUSTACEA:</b>		<i>Rana catesbiana</i>	Bull frog
Cragonidae	Shrimps	<i>Rana clamitans</i>	Green frog
<i>Homarus americanus</i>	Lobster	<b>REPTILIA:</b>	
<i>Cancer irroratus</i>	Rock crab	<i>Chelydra serpentina</i>	Snapping turtle
<b>PISCES:</b>		<i>Chrysemys picta</i>	Painted turtle
<i>Petromyzon marinus</i>	Sea lamprey	Chelonidae; Dermochelidae	Sea turtles
<i>Squalus acanthias</i>	Spiny dogfish	<b>AVES:</b>	
<i>Raja</i> spp.	Skates	<i>Gavia immer</i>	Loon
<i>Acipenser oxyrinchus</i>	Sturgeon	<i>Ardea herodias</i>	Great blue heron
<i>Anguilla bostoniensis</i>	Eel	<i>Branta canadensis</i>	Canada goose
<i>Clupea harengus</i>	Herring	<i>Branta bernicla</i>	Brant
<i>Alosa sapidissima</i>	Shad	Anatinae; Nyrociniae	Surface feeding and diving ducks
<i>Coregonus clupeaformis</i>	Whitefish		
<i>Salmo salar</i>	Atlantic salmon		
<i>Salvelinus fontinalis</i>	Salt-water trout; brook trout		

TABLE 1.—(Continued)

Scientific Classification	English Name	Scientific Classification	English Name
AVES (Continued):		GYMNASPERMAE (Continued):	
<i>Bonasa umbellus</i>	Ruffed grouse	<i>Thuja occidentalis</i>	White cedar; arborvitae
Charadrioidae	Shorebirds	<i>Juniperus</i> spp.	Red cedar; juniper
Larinae	Gulls	ANGIOSPERMAE:	
<i>Plautus impennis</i>	Great auk	<i>Zostera marina</i>	Eelgrass
<i>Ectopistes migratorius</i>	Passenger pigeon	<i>Hierochloë odorata</i>	Sweet grass
<i>Corvus brachyrhynchos</i>	Raven	<i>Acorus calamus</i>	Muskroot; sweet flag
<i>Turdus migratorius</i>	Robin	<i>Salix</i> spp.	Willows
MAMMALIA:		<i>Juglans cinerea</i>	Butternut
<i>Euarctos ameri anus</i>	Black bear	<i>Corylus</i> sp.	Hazelnut
<i>Procyon lotor</i>	Raccoon	<i>Betula</i> spp.	Birches
<i>Martes americana</i>	Marten	<i>Betula papyrifera</i>	Canoe birch; paper birch
<i>Martes pennanti</i>	Fisher	<i>Alnus</i> spp.	Alder
<i>Mustela cicognani</i>	Weasel	<i>Fagus grandifolia</i>	Beech
<i>Mustela vison</i>	Mink	<i>Quercus</i> spp.	Oaks
<i>Gulo luscus</i>	Wolverine	<i>Coptis groenlandica</i>	Goldthread
<i>Lutra canadensis</i>	Otter	<i>Ribes</i> spp.	Currants; gooseberries
<i>Mephitis mephitis</i>	Skunk	<i>Pyrus coronaria</i>	Crab apple
<i>Vulpes fulva</i>	Red fox	<i>Crataegus</i> spp.	Hawthorn
<i>Canis lycaon</i>	Wolf	<i>Fragaria virginiana</i>	Strawberry
<i>Lynx canadensis</i>	Lynx	<i>Rubus</i> , spp.	Raspberries; blackberries; dewberries
<i>Phoca vitulina</i>	Harbor seal	<i>Prunus</i> spp.	Wild cherries; black cherries; beach plum; sand plum
<i>Phoca groenlandica</i>	Greenland seal	<i>Apios americana</i>	Wild bean; groundnut
<i>Odobenus rosmarus</i>	Walrus	<i>Acer pennsylvanicum</i>	Moosewood; striped maple
<i>Marmota monax</i>	Woodchuck	<i>Acer saccharum</i>	Sugar maple; rock maple
<i>Sciurus carolinensis</i>	Gray squirrel	<i>Acer rubrum</i>	Red maple
<i>Castor canadensis</i>	Beaver	<i>Aralia nudicaulis</i>	Sarsaparilla
<i>Ondatra zibethica</i>	Muskrat	<i>Ledum groenlandicum</i>	Labrador-tea
<i>Erethizon dorsatum</i>	Porcupine	<i>Arctostaphylos alpina</i>	Bearberry
<i>Lepus americanus</i>	Snowshoe rabbit; varying hare	<i>Gaylussacia</i> spp.	Huckleberries
<i>Odocoileus virginianus</i>	White-tailed deer; Virginia deer	<i>Vaccinium</i> spp.	Blueberries; cranberries
<i>Alces americana</i>	Moose	<i>Frazinus americana</i>	White ash
<i>Rangifer caribou</i>	Woodland caribou	<i>Frazinus nigra</i>	Black ash; brown ash
Cetacea	Whales and porpoises	<i>Mitchella repens</i>	Partridgeberry
GYMNASPERMAE:		<i>Sambucus canadensis</i> , <i>S. pubens</i>	Elderberries
<i>Pinus strobus</i>	White pine	<i>Helianthus tuberosus</i>	Artichoke; wild potato
<i>Larix laricina</i>	Tamarack	<i>Taraxacum officinale</i>	Dandelion
<i>Picea glauca</i>	White spruce		
<i>Picea mariana</i>	Black spruce		
<i>Abies balsamea</i>	Balsam fir		
<i>Tsuga canadensis</i>	Hemlock		

## LITERATURE CITED

- ALGER, A. L. *In Indian tents; stories told by Penobscot, Passamaquoddy, and Micmac Indians*: 139 pp. Boston, 1897.
- ANON. *Micmac wampum belt*. Free Mus. Science and Art, Univ. Pennsylvania Bull. 4: 184-187. 1898.
- BYERS, DOUGLAS S. *The environment of the northeast*. In: "Man in Northeastern North America." Papers Robert S. Peabody Foundation for Archeology 3: 3-32. Edited by F. Johnson. 1946.
- CHAMBERLAIN, MONTAGUE. *Mammals of New Brunswick*. Bull. Nat. Hist. Soc. New Brunswick 1(3) art. 4: 37-40. 1884.
- . *The Indians in New Brunswick in Champlain's time*. Acadensis 4: 280-295. 1904.
- COONEY, ROBERT. *History of northern New Brunswick and Gaspé*. Halifax, 1832.
- COOPER, J. M. *Is the Algonquian family hunting ground system pre-Columbian?* Amer. Anthropol. 41: 66-90. 1939.
- . *The culture of the northeastern Indian hunters: A reconstructive interpretation*. In: "Man in Northeastern North America." Papers Robert S. Peabody Foundation for Archeology 3: 272-306. Edited by F. Johnson. 1946.
- DENYS, NICOLAS. *The description and natural history of the coasts of N. A. (Acadia) trans. & ed. by W. F. Ganong*. Publ. Champlain Soc. 2: 625 pp. 1908.
- ELDER, WILLIAM. *The aborigines of Nova Scotia*. North Amer. Rev. 112: 1-30. 1871.
- FLANNERY, REGINA. *An analysis of coastal Algonquian culture*. Catholic Univ. Amer. Anthropol. Ser. no. 7: 1-219. 1939.
- . *The culture of the northeastern Indian hunters: A descriptive survey*. In: "Man in Northeastern North America." Papers Robert S. Peabody Foundation for Archeology 3: 263-271. Edited by F. Johnson. 1946.

- FOWLER, JAMES. *On shell heaps*. Ann. Rep. Smithsonian Inst. for 1870: 389. 1871.
- GANONG, W. F. *The economic Mollusca of Acadia*. Bull. Nat. Hist. Soc. New Brunswick no. 8 (art. 1): 3-116. 1889.
- HADLOCK, WENDELL S. *War among the Northeastern Woodland Indians*. Amer. Anthrop. **49**(2): 204-221. 1947a.
- . *The significance of certain textiles found at Redbank, New Brunswick, in relation to the history of the culture area*. Acadian Nat. **2**(8): 49-62. 1947b.
- HAGAR, STANSBURY. *Micmac customs and traditions*. Amer. Anthrop., o.s., **8**: 31-42. 1895.
- . *Micmac magic and medicine*. Journ. Amer. Folk-lore **9**: 170-177. 1896.
- HALLIDAY, W. E. D. *A forest classification for Canada*. Canada Dept. of Mines and Resources. Lands, Parks and Forests Branch. Forest Service Bull. 89: 50 pp. Ottawa, 1937.
- HALLOWELL, A. I. *The size of Algonkian hunting territories: A function of ecological adjustment*. Amer. Anthrop. **51**(1): 35-45. 1949.
- HENSHAW, H. W. *Indian origin of maple sugar*. Amer. Anthrop. **3**: 341-351. 1890.
- JONES, J. M. *Communication concerning Kitchen-middens at St. Margaret's Bay, Nova Scotia*. Ann. Rep. Smithsonian Inst. for 1863: 370-371. 1864.
- LECLERCQ, CHRISTIEN. *New relation of Gaspesia*. Trans. and ed. with reprint of original by W. F. Ganong. Publ. Champlain Soc. **5**: 452 pp. 1910.
- LELAND, CHARLES G. *The Algonquin legends of New England, or myths and folk-lore of the Micmac, Pasamaquoddy, and Penobscot tribes*. Boston, 1884.
- LESCARBOT, MARC. *Nova Francia, a description of Acadia, 1606*. Trans. by P. Erondelle 1609 with intro. by H. P. Biggar. 346 pp. New York, 1928.
- LOOMIS, F. B., AND YOUNG, D. B. *On the shell heaps of Maine*. Amer. Journ. Sci., ser. 4, **34**: 17-42. 1912.
- MACLEOD, W. C. *Conservation among primitive hunting peoples*. Sci. Monthly **43**(6): 562-566. 1936.
- MAILLARD, A. S. *Account of the customs and manners of the Micmakis and Maricheets*: 138 pp. London, 1758.
- MICHELSON, TRUMAN. *Micmac tales*. Journ. Amer. Folk-lore **38**: 33-54. 1925.
- MORISON, M. B. *The forests of New Brunswick*. Canada Dept. of Mines and Resources. Lands, Parks and Forests Branch. Forest Service Bull. **91**: 112 pp. 1938.
- PARSONS, ELSIE C. *Micmac folk-lore*. Journ. Amer. Folk-lore **38**: 55-133. 1925.
- PATTERSON, G. *The stone age in Nova Scotia, as illustrated by a collection of relics presented to Dalhousie College*. Proc. Trans. Nova Scotian Inst. Sci. **7**: 231-252. 1889.
- PIERS, HARRY. *Relics of the stone age in Nova Scotia*. Proc. Trans. Nova Scotian Inst. Sci. **9**: 26-58. 1895.
- . *Brief account of the Micmac Indians of Nova Scotia and their remains*. Proc. Trans. Nova Scotian Inst. Sci. **13**: 99-125. 1912.
- PRINCE, JOHN D. *A Micmac manuscript*. Proc. 15th Int. Congr. Americanists, Quebec: 87-124. 1906.
- RAND, SILAS T. *A short statement of facts relating to the history, manners, customs, languages, and literature of the Micmac tribe of Indians*. Halifax, 1850.
- . *Legends of the Micmacs*. New York and London, 1894.
- SEARS, PAUL B. *The archeology of environment of eastern North America*. Amer. Anthrop. **34**: 610-622. 1932.
- SMITH, HARLAN A., AND WINTEMBERG, W. J. *Some shell-heaps in Nova Scotia*. Canada Dept. Mines, Nat. Mus. of Canada, Bull. **47**: 1-192 (anthrop. series, No. 9). Ottawa, 1929.
- SPECK, FRANK G. *Some Micmac tales from Cape Breton Island*. Journ. Amer. Folk-lore **28**: 59-69. 1915a.
- . *The family hunting band as the basis of Algonkian social organization*. Amer. Anthrop. **17**: 289-305. 1915b.
- . *Medicine practices of the northeastern Algonquians*. Proc. 19th Int. Congr. Americanists, Washington, 1915: 303-321. 1917.
- . *Beothuk and Micmac*. Indian Notes and Monographs, no. 22. Heye Foundation, 1922.
- . *Reptile-lore of the northern Indians*. Journ. Amer. Folk-lore **36**: 273-280. 1923.
- . *Aboriginal conservators*. Bird-lore **40**: 258-261. 1938.
- SPECK, FRANK G., AND DEXTER, RALPH W. *Molluscan food items of the Houma Indians*. Nautilus **60**(1): 34. 1946.
- . *Utilization of marine life by the Wampanoag Indians of Massachusetts*. Journ. Washington Acad. Sci. **38**(8): 257-265. 1948.
- SPECK, FRANK G., AND EISELEY, L. C. *Significance of hunting territory systems of the Algonkian in social theory*. Amer. Anthrop. **41**: 269-280. 1939.
- STONE, ERIC. *Medicine among the American Indians*: 139 pp. 1932.
- WALLIS, W. D. *Medicines used by the Micmac Indians*. Amer. Anthrop. **24**: 24-30. 1922.
- WARD, C. C. *Caribou-hunting*. Scribners Monthly **17**(2): 234-247. 1878.
- WISSLER, CLARK. *The relation of nature to man in aboriginal America*: 248 pp. New York, 1926.

PALEONTOLOGY.—*New crinoids from the Pitkin of Oklahoma.* HARRELL L. STRIMPLE, Bartlesville, Okla. (Communicated by Alfred R. Loeblich, Jr.)

A prolific crinoid fauna has been discovered by Claude Bronaugh, of Afton, Okla., in the upper few feet of the Pitkin limestone formation in outcrops of the Cookson Hills southeast of Fort Gibson, Okla. Specimens have subsequently been collected by Mr. Bronaugh, Mrs. Hazel Bronaugh, Mrs. Melba Strimple, and the author on several field excursions. Several of the new forms are described below.

*Telikosocrinus*, n. gen.

*Description*.—Crown is of moderate length, expands rapidly. Dorsal cup composed of five small, upflared IBB, five large BB, five large RR, and three anal plates in normal (primitive) arrangement. Forty or more biserial arms are indicated. First bifurcation with the first primibrachial in each ray and a second branching with, or about, the fifth secundibrachial in all rays. Thereafter, the outer rays usually, but not always, continue to their termination without further bifurcation and the inner rays branch again. The next bifurcation normally takes place in only the outer arms and the fourth dichotomy, when present, occurs only in the ensuing inner rays.

Column is moderately pentagonal, pierced by a small pentalobate lumen. Anal tube terminates with a few irregular, upwardly or outwardly directed spinose plates.

*Genotype*.—*Telikosocrinus caespes*, n. sp.

*Known range*.—Chester, North America.

*Remarks*.—This genus has certain characteristics in common with *Pelecocrinus* Kirk (1941) and *Hydreionocrinus* de Koninck (1858). All three genera have more or less erect, cone-shaped dorsal cups with three anal plates in normal (primitive) arrangement. *Pelecocrinus* is readily separable in having a round stem, articulating facets which fail to fill distal faces of RR, uniserial arms, and 10 or more primibrachials above anterior radial. *Hydreionocrinus* is more difficult to distinguish and is probably closely related. The dorsal cup is shallow, interbasal sutures exceedingly short, or absent, and the biserial arms branch only in the inner rays after the second dichotomy.

The form described by Laudon (1941) as *Pelecocrinus stereosoma* from the middle Pitkin is reported to have uniserial arms with sporadic biserial development. Since the articulating facets

of this species fill the distal faces of RR, and as there is no evidence of numerous PBrBr in the anterior ray, the species does not appear to belong with *Pelecocrinus*. It seems better assigned as *Telikosocrinus stereosoma* (Laudon), n. comb.

*Telikosocrinus caespes*, n. sp.

Figs. 1-4

*Description*.—Crown moderately expanded, curving slightly inwardly at distal extremity and devoid of ornamentation. Dorsal cup high cone-shaped with a tendency toward a spherical outline. Sutures are mildly impressed giving cup plates a tumid appearance. Five IBB extend beyond the columnar scar and are visible in side view of the dorsal cup. Five BB are fairly large and five RR are wide, substantial plates. Three anal plates occupy the broad posterior interradius and are in primitive arrangement.

There are approximately 50 biserial arms. First PBrBr are wide, low, axillary and distal faces of RR. A biserial arrangement is rapidly attained by the SBrBr and second bifurcation takes place with the fifth to tenth SBrBr. In the holotype and most paratypes the outer rays remain unbranched and the next division of the inner rays takes place normally with about the ninth TBrBr. When another dichotomy occurs it is in an outer ray. A young paratype branches in either the outer or inner rays after the second dichotomy. Pinnules are delicate and not often preserved in place.

Anal sac is elongate, extending almost to the distal extremities of the rami. Several spinose, irregular plates mark the termination of the sac. Proximal columnals are mildly pentagonal and are alternately expanded. The lumen is pentalobate and small.

*Measurements in mm.*—As follows:

	Holo- type	Figured paratype	Para- type type
Height of crown.....	—	21.5	29.6
Height of dorsal cup.....	3.9	3.2	2.8
Maximum width of cup.....	10.2	7.2	9.7
Width of IBB circlet.....	5.2	2.7	2.8
Diameter of proximal columnal.....	2.7	1.9	2.0
Length of l. post. B <sup>1</sup> .....	3.2	1.5	2.1
Width of l. post. B.....	3.7	2.3	2.4
Length of interbasal suture <sup>1</sup> .....	1.2	0.5	0.9
Length of l. ant. R <sup>1</sup> .....	2.8	2.0	2.5
Width of l. ant. R.....	5.8	3.7	4.6
Length of interrarial suture <sup>1</sup> .....	1.4	1.3	1.4
Height of PBr.....	2.9	2.2	2.8
Width of PBr.....	5.9	3.8	4.5

<sup>1</sup> Excluding consideration of surface curvature.

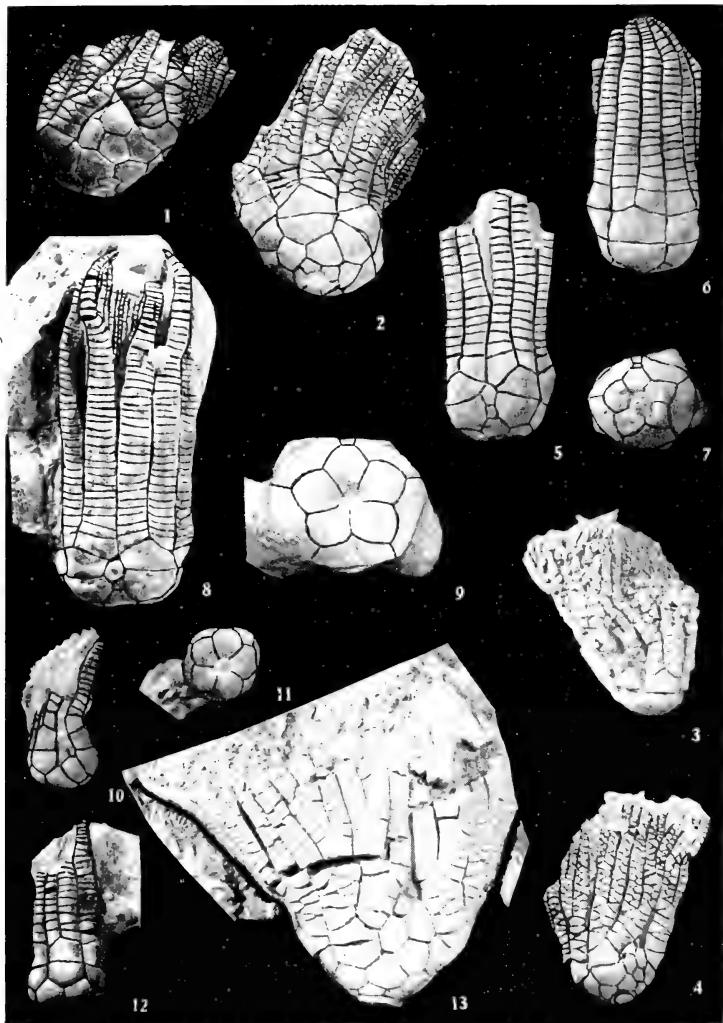

FIGS. 1-4.—*Telikosocrinus caespes*, n. gen. and sp.: 1, 2, Holotype from posterior and anterior,  $\times 1.8$ ; 3, 4, small paratype from anterior and posterior,  $\times 1.7$ . FIGS. 5-9.—*Phanoecrinus irregularis*, n. sp.: 5-7, Small paratype from posterior, anterior, and base,  $\times 1.7$ ; 8, 9, holotype from posterior and base,  $\times 1.4$ . FIGS. 10-12.—*Phanoecrinus modulus*, n. sp., holotype from posterior, base, and anterior,  $\times 1.8$ . FIG. 13.—*Telikosocrinus residuus*, n. sp., holotype from posterior,  $\times 1.7$ .

*Remarks.*—This species has a dorsal cup somewhat similar to that of *T. stereosoma* (Laudon); however, the IBB of the latter species are more pronounced and the cup is more elongate. *T. stereosoma* has primarily uniserial arms and a stronger tendency toward bifurcation in the outer rays after the second main dichotomy. Only one of six observed specimens of *T. caespes* showed any decided tendency toward bifurcation in the outer main rays after the second branching and all arms were biserial.

*T. residuus* has a more evenly expanded dorsal cup and the arms have a flattened exterior not found in *T. caespes*.

*Occurrence and horizon.*—Approximately 4 miles southeast of Greenleaf Lake, Cookson Hills, Okla.; upper Pitkin limestone formation, Chester, Mississippian.

*Types.*—Holotype and one paratype collected by Melba Strimple. Figured paratype collected by Claude Bronaugh. To be deposited in the U. S. National Museum.

**Telikosocrinus residuus, n. sp.**

Fig. 13

*Description.*—Crown is devoid of ornamentation, expands rapidly and evenly from columnar attachment. Dorsal cup cone-shaped, composed of five IBB, which are visible in side view of cup, five large BB, five large RR, and three anal plates. Posterior interradius is broad and plates are in normal (primitive) arrangement with RA resting obliquely against r. post. B and post. B, supporting RX above. Proximal edge of anal X is in broad contact with post. B and RA to the right.

There are approximately 50 arms indicated, exteriors flattened, biserial. First PBrBr low, axillary, fill distal faces of RR. Second bifurcation takes place with fourth or fifth SBrBr, thereafter, outer rays remain unbranched and inner rays branch with about the ninth TBrBr. After the third bifurcation the inner rays remain unbranched but the outer rays branch again on about the tenth or eleventh QBrBr. Pinnules are rather delicate and of moderate length.

Proximal columnal is large, pentagonal. Anal sac has not been observed except for the spinose terminating plates.

*Measurements in mm.*—As follows:

	<i>Holotype</i>
Height of dorsal cup.....	5.4
Maximum width of cup.....	13.9
Width of IBB circle.....	5.8

	<i>Holotype</i>
Diameter of proximal columnal.....	3.8
Length of l. post. B.....	3.1
Width of l. post. B.....	4.8
Length of interbasal suture.....	1.7
Length of l. ant. R.....	3.0
Width of l. ant. R.....	5.5
Length of intraradial suture.....	2.1
Height of PBr.....	3.2
Width of PBr.....	5.5

*Remarks.*—Comparison with *T. caespes* and *T. stereosoma* have already been given. *T. residuus* is closely comparable to *Hydreionocrinus woodianus* de Koninck (1858) in some respects. The dorsal cup of the latter species is shallower and the arms have a slightly different pattern in that after the third dichotomy the arms continue to bifurcate only in the innermost rays.

*Occurrence and horizon.*—Approximately 4 miles southeast of Greenleaf Lake, Cookson Hills, Okla.; upper Pitkin limestone formation, Chester, Mississippian.

*Holotype.*—Collected by Claude Bronaugh. To be deposited in the U. S. National Museum.

**Genus Phanocrinus Kirk, 1941**

**Phanocrinus irregularis, n. sp.**

Figs. 5-9

*Description.*—Crown elongate, tubular-shaped. Dorsal cup shallow, broad, base shallowly concave. Five IBB are small, confined to the basal concavity; five BB are large, distal extremities curved into basal concavity where they have broad median grooves; five RR are large, wide; and two small anal plates in posterior interradius. RA is in oblique but broad contact with post. B and supports the slightly larger anal X above.

Arms are 10, stout, uniserial, slow tapering. PBrBr are axillary, low, wide. First SBrBr are rather large tall plates but subsequent brachials are low broad plates. Pinnules are of moderate size.

Proximal columnals are round and pierced by a small pentalobate lumen. Tegmen is unknown. Entire crown is devoid of ornamentation.

*Measurements in mm.*—As follows:

	<i>Holotype</i>	<i>Figured paratype</i>
Height of crown.....	48.6	28.4
Height of dorsal cup.....	5.9	3.0
Maximum width of cup.....	16.8	11.2
Diameter of proximal columnal.....	2.1	1.7
Length of l. post. B <sup>1</sup> .....	6.0	?
Width of l. post. B <sup>1</sup> .....	5.1	3.7
Length of interbasal suture <sup>1</sup> .....	3.4	?
Length of r. ant. R <sup>1</sup> .....	6.1	3.8
Width of r. ant. R <sup>1</sup> .....	8.8	6.0
Length of intraradial suture.....	3.0	2.5

	Holo- type	Figured paratype
Height of PBr.....	4.1	4.4
Width of PBr.....	8.9	6.0

<sup>1</sup> Measurements along curvature of plates.

*Remarks.*—Only five specimens of *Phanocrinus* have been found in the horizon under study. Of these four are readily identified as *P. irregularis* and have the advanced arrangement of anal plates wherein RA has migrated to the dominant posterior position with anal X resting on the upper surface of RA, and RX has been entirely eliminated from the cup. It is considered significant that RA has also become small, thus indicating probable resorption. Such modification of the plates of the posterior interradius has been termed “Developmental Trend A” by the author (1948).

*Phanocrinus cooksoni* Laudon (1941) is closely comparable but has a higher cup with BB participating strongly in the outer walls of the dorsal cup.

*Occurrence and horizon.*—Approximately 4 miles southeast of Greenleaf Lake, Cookson Hills, Okla.; upper Pitkin, limestone formation, Mississippian.

*Types.*—Holotype and figured paratype collected by Melba Strimple. To be deposited in the U. S. National Museum.

**Phanocrinus modulus, n. sp.**

Figs. 10-12

*Description.*—Crown of moderate length, tubular-shaped, with distal extremity tapered to a point. Dorsal cup truncate bowl-shaped, with erect lateral sides. Five IBB are minute, confined to basal concavity and almost entirely covered by proximal columnals. Five BB large, curve strongly out of basal concavity to form a good portion of the lateral walls of the cup. Five RR large, only slightly wider than high. Three anal plates occupy the posterior interradius. RA is large, elongate, rests obliquely on post. B and

r. post. B. Anal X is in contact with post. B but is strongly encroached upon by RA to the right. RX is in narrow contact with distal face of RA.

There are ten uniserial arms. PBrBr are large, axillary. SBrBr have strongly curved exteriors and are rather stout plates.

Proximal columnals are round, small, heavily crenulated. Tegmen is unknown.

*Measurements in mm.*—As follows:

	Holo- type
Height of crown.....	20.1
Height of dorsal cup.....	3.6
Maximum width of cup.....	8.3
Diameter of proximal columnal.....	1.5
Length of l. post. B.....	4.8
Width of l. post. B.....	3.8
Length of interbasal suture.....	2.7
Length of r. ant. R.....	2.7
Width of r. ant. R.....	4.0
Length of interradial suture.....	1.8
Height of PBr.....	2.7
Width of PBr.....	4.0

*Remarks.*—*P. modulus* is a small species readily distinguished from other described species by the large RA, short stout arms and the outline of the dorsal cup in side view. The nature of the plates in the posterior interradius indicates modification toward “Developmental Trend B” as outlined by the author (1948), and is almost identical to figure 4 of that study.

*Occurrence and horizon.*—Approximately 4 miles southeast of Greenleaf Lake, Cookson Hills, Okla.; upper Pitkin limestone formation, Chester, Mississippian.

*Holotype.*—Collected by the author. To be deposited in the U. S. National Museum.

REFERENCES

DE KONINCK, L. G. Bull. Acad. Roy. Bruxelles (2) 4: 93-97, pl. 2, figs. 5, 5a. 1858.  
 KIRK, EDWIN. Journ. Pal. 15: 82. 1941.  
 LAUDON, L. R. Journ. Pal. 15: 385-386, pl. 56, figs. 1, 2. 1941.  
 STRIMPLE, H. L. Journ. Pal. 22: 491-492, figs. 1-8. 1948.

ENTOMOLOGY.—*Jordanopsylla allredi*, a new genus and species of flea from Utah (*Siphonaptera*).<sup>1</sup> ROBERT TRAUB, Major, MSC, and VERNON J. TIPTON, 1st Lt., MSC.

Under a research grant of the U. S. Public Health Service, Dr. D. E. Beck and Donald M. Allred, of the Department of Entomology, Brigham Young University, have been conducting a survey of arthropods of potential medical importance in Utah. In the excellent collection of ectoparasites obtained by these workers is a remarkable flea here described as a new genus of the family Hystrichopsyllidae, subfamily Anomiopsyllinae.

*Jordanopsylla*, n. gen.

*Diagnosis*.—Unique in that the maxillary lobe is reduced, almost inapparent. Separated from all other genera in the family by the following combination of characters: Pronotal and genal combs both absent; unmodified terga with two rows of bristles. The only genus in the subfamily in which any of the following characters is present: A well-developed lateral metanotal area; a striarium on the second abdominal sternum; metatibiae with mesal bristles extending from base to apex; pleural arch distinct.

*Description*.—Clypeal tubercle absent. Pre-antennal region of head with one row of bristles. Postantennal region with but one row of bristles, and that marginal. Eye reduced. Apex of gena subangulate or somewhat rounded, not acuminate. Maxillary lobe (Fig. 1, *MX.*) weakly sclerotized, reduced, not acuminate. Apical segment of maxillary palpus about  $3\frac{1}{2}$  times as long as broad. Labial palpus (*L.P.*) very long, with apical segment arising distad of trochanter of forecoxa (*TR.*). Distal segment of labial palpus apically symmetrical, rounded. Pedicel of antenna normal, not ensheathing clavus. Bristles of pedicel longer than clavus (at least in female). Pronotum with one row of bristles; spines completely absent. Lateral metanotal area (Fig. 4, *L.M.*) broader than long. Pleural ridge of metasternosome fitting into a well-sclerotized socket (pleural arch) (*P.L.A.*). Metanotum (*MTN.*) dorsally as long or longer than mesonotum (*MSN.*). Mesepisternum (*MPS.*) with anteroventral angle somewhat acuminate; without bristles. Metepisternum

(*MTS.*) broad; dorsally convex; anterior margin evenly arcuate; with a long bristle; squamulum absent or vestigial. Metepimere (*MTM.*) free, not fused with metanotum; slightly broader than long. Procoxa with only approximately twelve lateral bristles (including marginals). Mesocoxae and metacoxae with thin mesal submarginal bristles scattered from base to apex. Tibial comb absent. Profemur with a few thin mesal bristles. Metatibia with approximately five dorsomarginal notches bearing paired bristles (including apical clump of three). First segment of metatarsus about two-thirds length of metatibia. All tarsi with but four pairs of plantar bristles on apical segment. Unmodified abdominal terga with first row of bristles distinct but reduced, not reaching spiracles. Striarium on second abdominal sternum well developed. Spiracles of metepimere subcylindrical, lacking a distinct ring; those of unmodified abdominal segments similar, but only about one-half the diameter. Some terga with apical spinelets. Female with one antepygial bristle. Anal stylet with an apical long bristle; others greatly reduced. Female eighth sternum reduced, but with a few very small bristles. Ventral anal lobe (Fig. 3, *V.A.L.*, and Fig. 7) not angulate. Eighth sternum with submarginal mesal bristles. Bursa copulatrix (Fig. 3, *B.C.*) apically subspherical. Spermatheca (*SP.*) with tail longer than the subovate head.

Genotype: *Jordanopsylla allredi*, n. sp.

The genus is named for Dr. H. E. Karl Jordan, F. R. S., who, in his ninetieth year, is as cooperative and helpful as ever, and whose present contributions to the systematics of fleas are as outstanding as those which firmly established his reputation as dean of students of Siphonaptera.

*Jordanopsylla allredi*, n. sp.

Figs. 1-7

*Types*.—Holotype female ex *Peromyscus eremicus*. Utah: Washington County, Grafton, coll. D. E. Beck and D. M. Allred, Dec. 17, 1950. Deposited in collections of U. S. National Museum. Paratype female *ibid.*, but from Springdale, Nov. 4, 1950. In collection of senior author. Both specimens somewhat distorted. Male unknown.

*Description*.—HEAD (Fig. 1): Frontoclypeal region evenly rounded. Anteroventral angle some-

<sup>1</sup> Published under the auspices of the Surgeon General, Department of the Army, who does not necessarily assume responsibility for the professional opinions expressed by the authors.



what acuminate, resembling a diminutive snout. Micropunctations or pores scattered from margin to preantennal row of bristles; extending over most of postantennal region. Preantennal row with lowest bristle on genal margin just behind insertion of maxillary palpi (*M.P.*); middle bristle apparently of variable length but shorter than other two, inserted near uppermost, which is at level of reduced eye. Maxillary lobe (*MX.*) weak, apparently not extending beyond base of prementum; apically subrounded or subtruncate. Labial palpus (*L.P.*) with the last two segments completely extending beyond apex of procoxa. Pedicel of antenna with some short submarginal or marginal bristles, but with most marginals extending beyond apex of subovate club. Clavus almost twice as long as broad. Antennal fossa

with five or six tiny dorsal hairs near caudal margin of head. Postantennal region with a fairly long ventromarginal bristle above middle of club; lowest bristle of marginal row at ventrocaudal angle, above vermiform vinculum; rest of row consisting of three fairly long bristles.

**THORAX:** Pronotal row with about five bristles on a side; with very small intercalary bristles between bases of larger ones. Mesonotum (Fig. 4, *MSN.*) with one complete row of bristles, with intercalaries and two subdorsal, more anterior, bristles; with about eight mesal pseudo-setae on a side. Mesepisternum (*MPS.*) with ventral margin much broader than dorsal margin. Mesepimere (*MPM.*) caudally rounded, with a bristle in anteroventral region and two subcaudal ones. Metanotum (*MTN.*) with three bristles

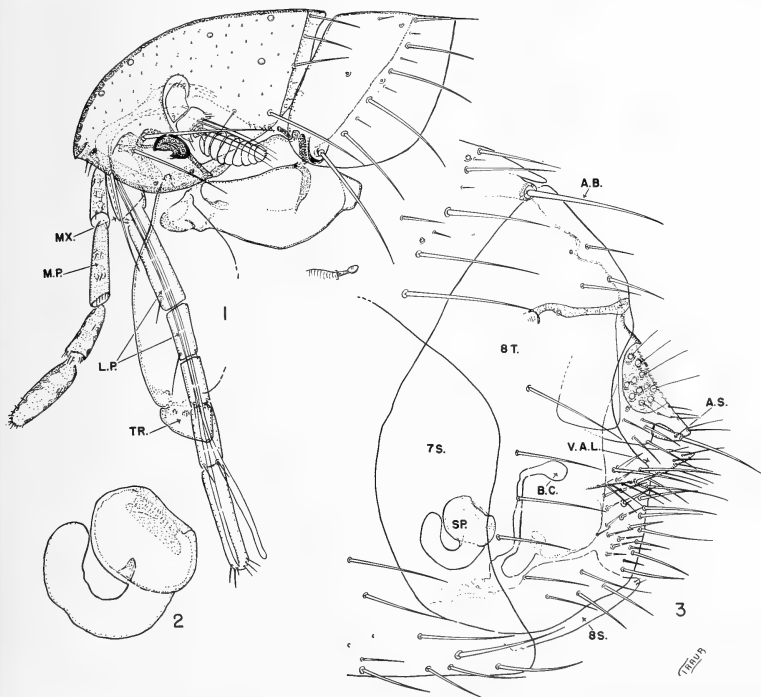

FIGS. 1-3.—*Jordanopsylla allredi*, n. gen., n. sp.: 1, Head and prothorax of female; 2, spermatheca; 3, modified abdominal segments.

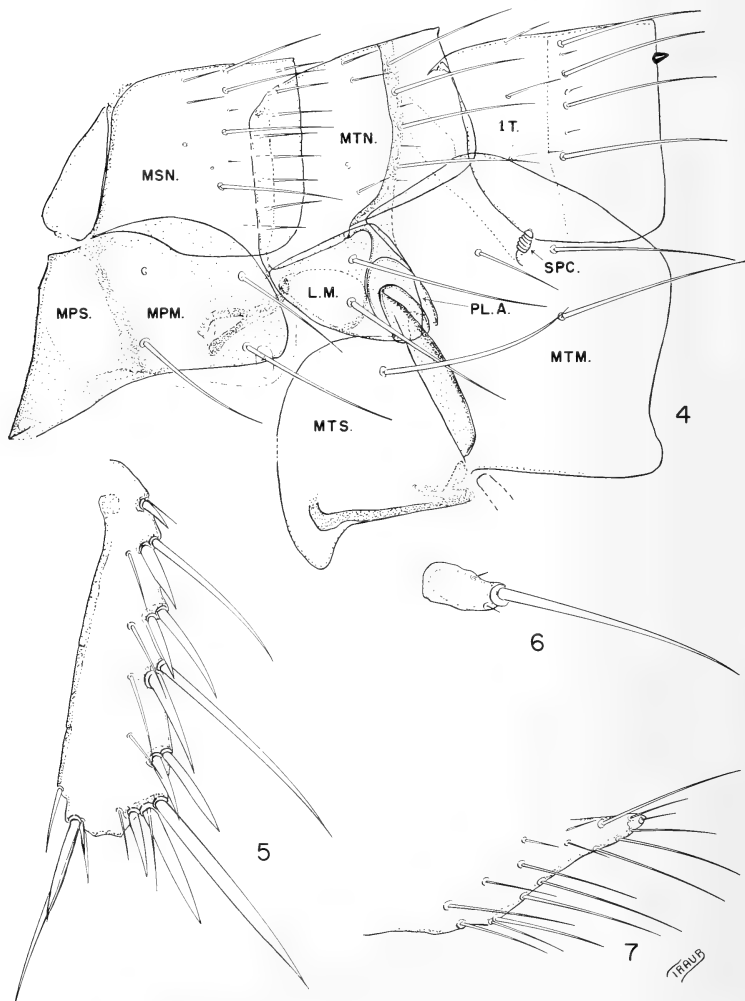

FIGS. 4-7.—*Jordanopsylla allredi*, n. gen., n. sp.: 4, Mesothorax, metathorax, and first tergum; 5, metatibia; 6, anal stylet; 7, ventral anal lobe.

TABLE 1.—COMPARATIVE TABLE: GENERA OF ANOMIOPSYLLINAE (FEMALES)

NO.	CHARACTER	JORDANOPSYLLA GEN. NOV.	ANOMIOPSYLLUS BAKER 1904	MEGARTHROGLOSSUS J.B.R. 1915	CONORHINOPSYLLA STEWART 1930	CALLISTOPSYLLUS J.B.R. 1915	STEMIATOMERA ROTHS. 1915
1	CLYPEAL TUBERCLE	0	+	+	0	+	+
2	INTEGRICIPITATE	+	+	+	+	+	0
3	SOME HEAD BRISTLES SPINIFORM	0	0	0	0	0	+ (CO)
4	ANTEROVENTRAL ANGLE OF HEAD ACUMINATE	±	0	0	+	0	0
5	NUMBER ROWS OF PREANTENNAL BRISTLES	1	1 (2)	1	2	2	4 (8)
6	EYE	REDUCED	0	VESTIGIAL	VESTIGIAL (REDUCED)	0	0
7	PEDICEL ENLARGED, PARTIALLY ENSHEATHING CLAVUS	0	0	0	0	+	+
8	LENGTH OF BRISTLES ON PEDICEL	> CLAVUS	1/2 CLAVUS	SHORT	SHORT	AS LONG AS 1/2 CLAVUS	> CLAVUS
9	MAXILLARY LOBE	REDUCED	NORMAL	NORMAL	NORMAL	NORMAL	NORMAL
10	MAX'Y PALPI (SEGMENT 4)—RATIO: LENGTH TO BREADTH	3.5:1	5:1	5:1	6:1	4.5:1	3:1
11	POSTANTENNAL BRISTLES	0-1-ROW	0-0-ROW	1(CO)-1-ROW	0-1-ROW	1-2-ROW	3 ROWS (1-ROW-ROW)
12	LABIAL PALPI—LENGTH (RE. LEG I)	FAR > TROCHANTERS	± TO TROCHANTERS	FAR > TROCHANTERS	TROCHANTERS	± APEX COXAE	± APEX COXAE
13	LABIAL PALPI—RATIO: LENGTH OF ULTIMATE SEG'T. TO PENULTIMATE	2:3:1	1.5:1	2.5-3:1	1.5-2:1	2:1	± 1:1
14	LABIAL PALPI—NUMBER OF SEGMENTS	5	4	5	5-8	4	4
15	LABIAL PALPI—APEX SYMMETRICAL	+	±	0	0	±	±
16	APEX OF GENAL LOBE	SUBANGULATE	SUBROUNDED	SUBTRUNCATE	(SUBTRUNCATE) SUBROUNDED	ACUTE	SUBACUTE (ACUTE)
17	PRONOTAL COMB	0	0	+	+	+	+
18	NUMBER OF LATERAL BRISTLES ON PROCOXA*(±)	12	12	± 23	32	25	30-35
19	RATIO: MESONOTUM TO METANOTUM (DORSAL MARGIN)	1:1:1	1.6:1	1.5:1	1.8:1	1.8:1	1.8:1
20	ANTEROVENTRAL MARGIN OF MESEPISTERNUM (MPS.)	SUBACUTE	SUBTRUNCATE	SUBROUNDED	SUBROUNDED	SUBTRUNCATE	SUBTRUNCATE
21	PSEUDOSETAE ON MESONOTUM	+	0	+	+	+	+

( ) = AN ALTERNATE CONDITION  
OR FIGURE

± = NOT APPLICABLE > BEYOND, GREATER THAN  
± = SOMEWHAT, APPROXIMATELY \* = INCLUDING MARGINALS

+ = CHARACTER PRESENT OR APPLIES  
0 = CHARACTER ABSENT

TABLE 2.—COMPARATIVE TABLE: GENERA OF ANOMIOPSYLLINAE (FEMALES)—Continued

NO.	CHARACTER	JORDANOPSYLLA GEN. NOV.	ANOMIOPSYLLUS BAKER 1904	MEGARTHROGLOSSUS J.B.R. 1915	CONORHINOPSYLLA STEWART 1930	CALLISTOPSYLLUS J.B.R. 1915	STEMIATOMERA ROTHS. 1915
22	LATERAL METANOTAL AREA	+	0	† (SMALL)	† (SMALL)	0	0
23	BRISTLE(S) ON LATERAL METANOTAL AREA	+	-	+	0	-	-
24	PLEURAL ARCH	+	0	0	C VESTIGIAL J	0	0
25	UPPER ANTERIOR MARGIN METEPISTERNUM (MIS.) CONCAVE	0	+	+	+	+	+
26	RATIO: DORSAL MARGIN METEPISTERNUM TO METANOTUM	1:1.7	1:3.2	1:2.3	1:2.4	1:2.6	1:6-8.5
27	BRISTLE ON METEPISTERNUM (MIS.)	0	+	+	+	0	0
28	MIS. WITH MARGINAL INTERNAL TUBERCLE (SQUAMULUM)	C VESTIGIAL J	+	+	+	+	+
29	METEPISTERNUM WITH DORSAL MARGIN CONVEX	+	±	0	0	0	0
30	SHAPE OF SPIRACLE OF METEPIMERE (FIG. 4, SPC.)	± CYLINDRICAL	± SPHERICAL	± SPHERICAL	OBLATE	± SPHERICAL	± SPHERICAL (COBLATE)
31	SHAPE OF SPIRACLE OF SECOND ABDOMINAL SEGMENT	± CYLINDRICAL	± SPHERICAL	± SPHERICAL	OVATE	± SPHERICAL	± SPHERICAL (COVATE)
32	RATIO: DIAMETER OF SPIRACLES, ITEM 30: ITEM 31	1.2:1	2:1	2:1	2:1	2:1	2:1
33	METEPIMERE — FUSION WITH METANOTUM	FREE	FUSED	FUSED	FUSED	FUSED	FUSED
34	MESOTIBIA WITH COMB OF DORSOLATERAL BRISTLES	0	0	0	0	0	+
35	RATIO: METATIBIAL LENGTH TO METATARSUS I	1.6:1	± 1.4:1	1.5:1	1.5:1	1.1:1	0.9:1
36	COXAE II & III WITH MESAL BRISTLES, FROM BASE TO APEX	+	0	0	0	0	0
37	COXAE II & III WITH CAUDOMARGINAL ACUMINATE SPUR	0	+	0	0	0	0
38	TARSI I — FIRST PAIR OF PLANTAR BRISTLES	ABSENT	DISPLACED (ABSENT ON III)	DISPLACED	DISPLACED	DISPLACED	DISPLACED
39	STRIARIUM ON ABDOMINAL SEGMENT II	+	0	0	0	0	0
40	NUMBER OF TERGAL ROWS OF BRISTLES	2	1	1	2	1	1
41	TOTAL NO. (±) APICAL SPINELETS — TERGA I — III	3(2) — 2-0	6-2-0	2-0-0	6-3(2)-2	7-3-0	6-0(2)-0
42	NUMBER OF ANTEPYGIDIAL BRISTLES (♀)	1	1	3	3	3	3

+ = CHARACTER PRESENT OR APPLIES  
 0 = CHARACTER ABSENT  
 - = NOT APPLICABLE  
 ± = SOMEWHAT, APPROXIMATELY  
 > = BEYOND, GREATER THAN  
 ( ) = AN ALTERNATE CONDITION OR FIGURE

preceding a row of four long bristles; the row with intercalaries. Lateral metanotal area (*L.M.*) with margins well sclerotized; subcordate (including region overlapping pleural arch); pitched or inclined slightly forward and upward; with two large bristles. Metepisternum (*MTS.*) slightly broader than long; with a long bristle near posterodorsal angle. Pleural arch (*PLA.*) well developed, approximately twice as broad as long. Metepimere (*MTM.*) with about three bristles.

**LEGS:** Procoxa with about 12 lateral bristles, including marginals. Mesocoxae and metacoxae with fewer such bristles, but with one and two rows, respectively, of thin mesal bristles near anterior margin. Metatibia (Fig. 5) without mesal bristles. Femur with one or two lateral median bristles and a mesal row of thin bristles. None of bristles of hindtibia longer than length of segment. Measurements of tibiae and segments of tarsi (petiolate base deleted) of holotype shown in microns:

Leg	Tibia	Tarsal Segments				
		I	II	III	IV	V
Pro-	150	55	55	50	45	105
Meso-	275	90	110	70	50	120
Meta-	375	255	150	90	50	130

Second segment of metatarsus with two apical bristles extending distad of apex of fourth segment.

**ABDOMEN:** First tergum (Fig. 4, *1T.*) with two or three bristles preceding a full row; with one or two apical spinelets per side. Basal sternum with four bristles, the uppermost above the striarium. Unmodified terga with lowest bristle of first row not inserted below third bristle of second row; the second row with intercalaries. Unmodified sterna with about two ventral bristles. Seventh sternum (Fig. 3, *7S.*) with caudal margin broadly and shallowly concave; with about five longish bristles in an oblique row and three ventromarginal ones in a line with lowest of oblique row; with a few smaller submarginal bristles above first of the ventral row. Eighth tergum (*8T.*) with only about three short bristles above the vermiform spiracle; with three irregular but vertical rows of bristles below the ventral anal lobe, some of those of the first two rows actually mesal; the marginal bristles the longest; with four long median bristles and about five subventral. Eighth sternum reduced, but apparent, with two short apical hairs. Anal stylet

(*A.S.* and Fig. 6) somewhat more than twice as long as broad; with a long apical bristle and perhaps a vestigial dorsal and ventral one. Ventral anal lobe (*V.A.L.* and Fig. 7) not heavily sclerotized; caudally slightly concave; with long thin marginal bristles and submarginals which are usually shorter. Spermatheca (*SP.* and Fig. 2) with head ovate, broader than long; tail upturned but not extending beyond head. Bursa copulatrix (*B.C.*) angled subapically, the apex subglobose, the proximal portion quite straight and fairly well sclerotized.

*Comment.*—The species is named for one of the collectors, Dorald M. Allred, who is contributing a great deal toward our knowledge of the Utah ectoparasite fauna.

#### AFFINITIES OF JORDANOPSYLLA

Many of the features that this genus possesses in common with certain other genera in the family, e. g., the marked reduction in chaetotaxy and the elongate stylets, are probably due to convergent evolution. It has been pointed out elsewhere (Traub, 1950; Traub, in press) that some of these features are considered characteristic of fleas which ordinarily are restricted to the nests of the hosts. Holland (1949) is also of the opinion that certain of these genera are nest-inhabiting forms. The reduction of the maxillary lobe in *Jordanopsylla* is probably an evolutionary step for a parasite which feeds when the host is sleeping, just as "sticktight" fleas with stout teeth on the hyperdeveloped stylets (e.g., *Hectopsylla* and *Rhynchopsyllus*) tend to have poorly developed labial palpi.

This new genus differs in a number of respects from other members of the subfamily Anomopsyllinae. Further, these differences are of a greater degree than those between the other genera. Tables 1 and 2 list and compare salient generic characters found in females of Anomopsyllinae (*Jordanopsylla*, *Anomopsyllus*, *Megarthroglossus*, *Conorhinopsylla*, *Callistopsyllus*, and *Stenistomera*). It will be seen that, in addition to the characters presented in the generic diagnosis above, *Jordanopsylla* is the only member of the subfamily in which: the metepimere is free; the pleural arch is present; the upper margin of the metepisternum is convex; and the internal marginal tubercle of the metepisternum is vestigial. It is felt that this genus represents a new tribe, which may be characterized as follows:

### Jordanopsyllini, n. tribe

Clypeal tubercle absent. Integrecipitate. Maxillary lobe reduced. Labial palpus elongate, extending beyond trochanter. Bristles on procoxa reduced in number; mesocoxa and metacoxa with a full vertical row of mesal bristles. Mesonotum subequal to metanotum in breadth. Lateral metanotal area prominent, well demarcated. Metepisternum with anterior and dorsal margins convex, not reduced. Typical spiracles subcylindrical. Metepimere not fused with metanotum. With a striarium on basal sternum. One antepygial bristle in female.

#### ACKNOWLEDGEMENTS

Dr. Karl Jordan, of the British Museum, Tring, kindly verified the tribal and generic status of this flea. We are indebted also to Miss Phyllis Johnson, Army Medical Service Graduate School, Washington, D. C., for critical review of the manuscript.

#### LIST OF ABBREVIATIONS

A.B. Antepygial bristle  
A.S. Anal stylet  
B.C. Bursa copulatrix

L.P. Labial palpus  
L.M. Lateral metanotal area  
M.X. Maxillary lobe  
M.P. Maxillary palpus  
M.P.M. Mesepimere  
M.P.S. Mesepisternum  
M.S.N. Mesonotum  
M.T.N. Mesonotum  
M.T.M. Metepimere  
M.T.S. Metepisternum  
P.L.A. Pleural arch of metathorax  
S.P. Spermatheca  
S.P.C. Spiracle  
T.R. Trochanter  
V.A.L. Ventral anal lobe of proctiger  
7.S. Seventh sternum  
1.T. First tergum  
8.T. Eighth tergum

#### LITERATURE CITED

- HOLLAND, G. P. *The Siphonaptera of Canada*. Canada Dept. Agr. Techn. Bull. 70 (Publ. 817). Ottawa, 1949.
- TRAUB, ROBERT. *Siphonaptera from Central America and Mexico: A morphological study of the aedeagus, with descriptions of new genera and species*. Zool. Mem. Chicago Nat. Hist. Mus. 1 (1): 1-127, 54 pls. 1950.
- — —. *Records and descriptions of fleas from Peru (Siphonaptera)*. Proc. Ent. Soc. Washington [in press].

ZOOLOGY.—A *luminescent new xystodesmid milliped from California*. H. F. LOOMIS, Coconut Grove, Fla., and DEMOREST DAVENPORT, University of California, Santa Barbara College, Santa Barbara, Calif.

A luminescent milliped has been discovered in central California. While luminescent chilopods have been reported, the question of self-luminous diplopods is still uncertain. There are several references in entomological literature to luminescent creatures that may or may not have belonged to this group or that may have been infected with luminous bacteria.

In 1949 a field party of plant ecologists in the mountains of Tulare County, Calif., first observed this handsome species at night near their camp and gathered living specimens, which were turned over to the junior author, who made various observations on them and sent preserved specimens to the senior author.<sup>1</sup> Unfortunately, all specimens were females and impossible to identify beyond placement in the family

Xystodesmidae, but a collection made a year later for the purpose of gathering males was successful. Taxonomic study of these specimens shows they unquestionably represent an undescribed species and genus with several outstanding structural peculiarities in addition to the phenominal one of being the first authenticated luminescent milliped.

#### Luminodesmus, n. gen.

*Gentotype*.—*Luminodesmus sequoiae*, n. sp.

*Diagnosis*.—Obviously related to the genus *Motyxia* Chamberlin but with more complicated gonopods, there being a fourth ramus, whereas *Motyxia* has but three; the dorsal tuberculation shows the greatest development of any known xystodesmid. A tendency to tuberculation has been observed in a few of the other species but the majority of them lack this form of sculpture.

*Description*.—Body of average size for the family or larger; both sexes strongly convex above. Segments 2, 3, and 4 with lateral carinae

<sup>1</sup> Our thanks are due Dr. E. N. Harvey, Princeton University, Princeton, N. J., for being instrumental in bringing about the collaboration on the present paper.

directed forward, those of segments 5 to 15 projecting outward, while on segments 16 to 19 they are caudally produced; posterior corners of all segments rounded except those of segment 19, which has them reduced in size but bluntly acute. On segment 1 a few scattered raised pustules usually are evident, but they are more evident and numerous on the succeeding segments, and from segment 9 or 10 backward distinct scattered pustules are present on the sides of the dorsum and in a continuous series close to the posterior margin, on segments 17 to 19 there being 14 to 20 tubercles in this series. First joint of legs produced distally below into a short, blunt, conic lobe; second joint with a distal, slender, very acute, spinelike lobe half as long as the joint. Males with a pair of high conic sternal processes between the fourth legs, these lacking in the female, but on the sterna of both sexes thereafter a process is present adjacent to each coxa, the posterior pair of each sternum being most prominent especially on the posterior segments. Gonopods with long basal joint, the outer half of the terminal joint composed of four very dissimilar divisions or branches. Claws on anterior legs of the males not differing from those of the female, being neither enlarged nor abruptly curved beyond middle.

*Luminodesmus sequoiae*, n. sp.

Two males, one the type, and several females collected May 12-14, 1950, at campground directly above Camp Nelson at the juncture of Belknap Creek and the south fork of the middle fork of Tule River, Sequoia National Forest, Tulare County, Calif., at an altitude of approximately 5,000 feet. Paratype females from same locality collected in mid-May 1949. The species was found at the lower limits of the Sequoia zone, where these giant trees were associated with *Pinus*, *Libocedrus*, *Quercus*, and *Acer*. The hardwood lower story of this association provided a relatively moist leafy litter in which many of the animals were collected.

Male type and paratype females deposited in the U. S. National Museum. Male and female paratypes deposited in the University of California, Berkeley, and female paratypes in the California Academy of Sciences, San Francisco.

*Description*.—Width of the largest specimen, a female, 7.5 mm; the living color light pinkish tan, more pronounced on lateral carinae, a dark internal structure showing through the body-wall

down the center of the dorsum. Opening through which the gonopods project transversely lenticular-triangular in shape, the posterior margin broadly and evenly rounded from side to side and thinly elevated high above the adjacent surface; anterior margin on each side oblique, meeting at a distinct angle at the midline of the body, the margin flat, not elevated above the adjacent surface. Gonopod as shown in the accompanying figure except that none of the basal hairs have been drawn.

*Remarks*.—This interesting species may occur in great numbers; it was possible to collect dozens of animals in the immediate vicinity of the campground at the type locality where, at night, they provided a striking display of luminescence. The appendages of the head, the legs, the margins of the terga, and the thin intersegmental junctures gave a pale greenish fire, the undulations of which were particularly striking when the animal was in motion. The source of the luminescence has not as yet been determined. The light is under no voluntary control on the part of the animal; it persists in daylight (subjection to darkness is not necessary for its appearance), and its source is fluorescent, as subjection of animals during daylight to ultraviolet light has demonstrated.

The function of luminescence in most creatures is to attract either the opposite sex or food. Since it appears that neither of these objectives can apply to this milliped, the members of its order being blind and all diplopods subsisting only on vegetable matter, the part luminescence plays in the life history of this species is problematical.



FIG. 1.—*Luminodesmus sequoiae*, n. gen. and sp.: Distal joint of left gonopod.

In the winter of 1932, W. B. Murbarger, of Kaweah, Calif., (in Tulare County about 30 miles north of Camp Nelson), sent specimens of a xystodesmid millipede to the Smithsonian Institution for identification, with the note that the animals were luminescent. Dr. O. F. Cook examined them and found all to be immature, impossible to identify, and requested additional specimens of Mr. Murbarger. These were sent, with a letter, on March 31, 1932, but apparently they also were young, for Dr. Cook, who was greatly interested in identifying the first known luminescent millipede and discussed it with the senior author, made no notes or comments on them, and no further attempts seem to have been made to secure adults.

Following identification of the foregoing Camp Nelson species, it now seems quite likely that Murbarger's specimens were *L. sequoiae*, and extracts from his two letters are of special interest. In his letter of February 24, 1932, he states that "these worms were taken beneath an oak tree and apparently were under no other trees in this locality (Kaweah, Tulare County, Calif.) Elev.

about 3,000 feet. Their one peculiarity is that at night they are luminous and visible for some distance." When Dr. Cook requested additional specimens he mentioned that the emission of light by the animals might be limited to a particular season, but in replying on March 31, Murbarger wrote: "As to their emission of light being confined to certain seasons, I cannot say. I first noticed them the past December. At no time since then have they failed to be luminous in the dark. During the daytime they can only be found under moist boards, logs and the like but at night they seem to roam about in the leaves, under trees and like retreats. Regarding the color of living specimens, I have sketched the accompanying crude diagram. Younger ones are of a whiter, more transparent color, no yellow being present, but in all sizes and ages the dark line down the back is noticeable." In his very creditable sketch the first segment is indicated as being buff colored and the "back gray-yellow, shading to bright yellow on the serrated edge." If Murbarger's specimens actually were *L. sequoiae*, it appears that this species remains luminescent from December to mid-May at least.

ZOOLOGY.—A new crayfish of the genus *Procambarus* from Louisiana, with a key to the species of the *Spiculifer* group. HORTON H. HOBBS, JR., Miller School of Biology, University of Virginia. (Communicated by Fenner A. Chace, Jr.)

Three species of the *Spiculifer* Group (Hobbs, 1942:119) of the genus *Procambarus* have been described from the southern United States, and their combined ranges extend from eastern Louisiana to the Altamaha River drainage in Georgia; of the three, *P. spiculifer* (LeConte, 1856:401) has the largest range, having been reported from Mississippi, Alabama, Georgia, and northern Florida; *P. versutus* (Hagen, 1870:51) from Mississippi, Alabama, and Florida; *P. vioscai* Penn (1946:27) from Louisiana and Mississippi.

The species belonging to the *Spiculifer* group may be readily distinguished from the other members of the genus by possessing the combination of an areola less than 28 per cent of the entire length of the carapace, and two lateral spines on each side of carapace immediately caudad of the cervical groove.

Members of this group are all inhabitants of streams and are more abundant in those

having a moderate current. Although there are few data available to indicate what factors in the environment limit their distribution to lotic situations, there is evidence that it is their inability to live in waters in which oxygen content is low. All these species have a broad areola (thus presumably a proportionally smaller gill chamber than do those species having a narrow one), and in American crayfishes, exclusive of the members of the genus *Cambarellus*, this feature is correlated with a lotic habitat. There is no evidence to suggest that the limiting factors in their ecological distribution are concerned with type of bottom, size of stream, pH, or hardness of the water, for both *spiculifer* and *versutus* have been taken from widely different types of streams.

The first specimens I saw of the species described below were collected by Percy Viosca from Talisheek, St. Tammany Parish, La., and have been deposited in the United States National Museum. Additional speci-



mens were sent to me by Dr. Edward C. Raney, of Cornell University, and I wish to thank him not only for these specimens but also for the many fine additions he has made to my collection.

I take great pleasure in naming this species in honor of Dr. George H. Penn, Jr., a mutual friend of Mr. Viosca's and mine, who has contributed much to our knowledge of the crayfishes of Louisiana.

*Procambarus penni*, n. sp.

*Holotypic male, form I.*—Body subovate, compressed laterally; abdomen longer than carapace (35.6–32.1 mm). Height of carapace slightly greater than width in region of caudodorsal margin of cervical groove (13.9–13.2 mm); greatest width of carapace a little cephalad of caudodorsal margin of cervical groove.

Areola relatively broad (4.2 times longer than wide) with four or five punctations in narrowest part. Cephalic section of carapace about 3.2 times as long as areola (length of areola about 23.6 per cent of entire length of carapace).

Rostrum long, excavate; sides subparallel to base of acumen which is set off by acute lateral spines. Acumen almost half as long as remainder of rostrum (5.0–11.4 mm). Margins of rostrum not swollen or conspicuously elevated. Upper surface bearing numerous small setae. Subrostral ridges poorly developed and not evident in dorsal aspect.

Postorbital ridges prominent, grooved laterad and terminating cephalad in acute spines. Suborbital angle almost obsolete, branchiostegal spine strong. Two strong acute lateral spines present on each side of carapace; upper surface of carapace punctate; lateral portion caudad of cervical groove granulate.

Cephalic section of telson with three spines in left and four in right caudolateral corners. Epistome with a small cephalomedian spine (see Fig. 8).

Antennules of the usual form with a strong acute spine present on ventral side of basal segment.

Antennae reaching caudad to middle of telson. Antennal scale long, of moderate width; widest cephalad of middle; outer distal margin with a strong spine.

Chela subovate, somewhat depressed, long and slender. Hand entirely tuberculate; tubercles beset with conspicuous plumose setae. Inner

margin of palm with a row of six tubercles, a prominent tubercle present on lower surface of palm at base of dactyl. Opposable surface of dactyl with four rounded tubercles on basal third, otherwise with crowded minute denticles; upper surface of dactyl with a few small setiferous tubercles at base, otherwise with setiferous punctations; lower and mesial surfaces similar to upper. Opposable margin of immovable finger with four tubercles on basal third and one large tubercle on lower opposable margin at midlength, otherwise entire opposable margin with minute denticles; other surfaces of finger with setiferous punctations. Both fingers with weak submedian ridges on upper and lower surfaces.

Carpus of first right pereiopod longer than wide (7.8–4.3 mm), shorter than inner margin of palm of chela (10.3 mm), with a shallow oblique groove above. Surface mesiad of groove with two longitudinal rows of five subsquamous tubercles; surface laterad of groove with setiferous punctations; mesial surface with two spike-like tubercles and a few additional small and scattered ones; lateral and lower surfaces with setiferous punctations; distal margin of lower surface with two prominent spines.

Merus of first right pereiopod punctate laterad and proximomesiad; mesiodistal surface with small tubercles; laterodistal surface with an acute spine; upper surface with small tubercles, and near distal end with two spikelike tubercles. Lower surface with an outer row of nine tubercles, only three of which are conspicuous, and a mesial row of 15; a few additional small tubercles flank these two rows.

Hooks present on ischiopodites of third and fourth pereiopods; hooks on third long and slender and only slightly recurved; hooks on fourth somewhat more stocky and strongly recurved. Basipodite of fourth pereiopod with a swelling opposite hook on ischiopodite. Coxopodites of fourth and fifth pereiopods with caudomesial projections: that on fourth heavy and inflated, that on fifth considerably smaller and somewhat compressed cephalocaudad.

First pleopod reaching cephalic side of coxopodite of third pereiopod when abdomen is flexed. Tip terminating in four distinct parts. Mesial process spiculiform and directed caudodistad. Cephalic process lying cephalomesiad of central projection, subacute, and extending slightly cephalomesiad. Caudal element consisting of three parts: caudal knob in lateral aspect acute

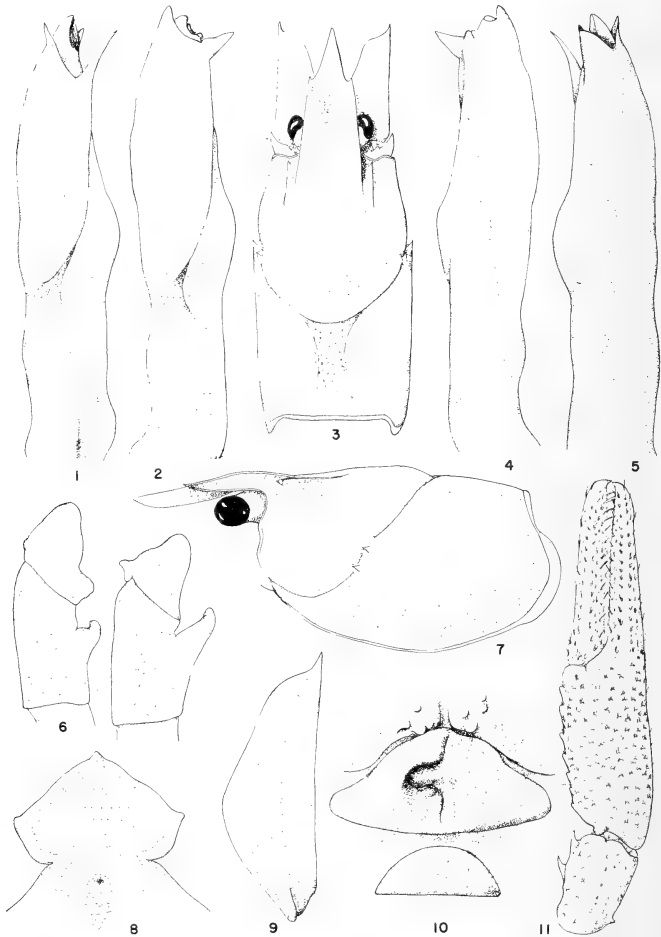

FIGS. 1-11.—*Procambarus penni*, n. sp.: 1, Mesial view of first pleopod of holotype; 2, mesial view of first pleopod of morphotype; 3, dorsal view of carapace of holotype; 4, lateral view of first pleopod of morphotype; 5, lateral view of first pleopod of holotype; 6, basipodites and ischiopodites of third and fourth pereopods of holotype; 7, lateral view of carapace of holotype; 8, epistome of holotype; 9, antennal scale of holotype; 10, annulus ventralis of allotype; 11, upper view of carpus and chela of holotype. (Pubescence removed from all structures illustrated except in Fig. 11.)

and noncorneous; caudal process slender, sub-lanceolate, and excavate caudad; accessory process extends across the proximocaudal face of the caudal process and central projection as a thin corneous ridge. Central projection corneous truncate distad, with fusion line of its two components clearly marked.

*Paratypic male, form II.*—Similar in most respects to the holotype, except in the reduced secondary sexual characters and in the distribution of a few spines. First pleopod with all processes reduced and noncorneous; caudal and adventitious processes not distinguishable in the caudal element; caudal knob very prominent (see Fig. 4).

*Allotypic female.*—This specimen, although badly mutilated, is the only specimen in this collection in which the annulus ventralis contained a sperm plug. The annuli of the more perfect specimens appear somewhat underdeveloped; therefore I have chosen this specimen with the "mature" annulus as the allotype. Annulus ventralis with a submedian depression; sinus originates slightly dextrad of midventral line about one-third of the length of the annulus from cephalic margin, extends dextrad and makes a hair-pin turn to the midventral line where it turns caudad and terminates directly caudad of its origin just cephalad of caudal margin of annulus. Sternum cephalad of annulus deeply cleft along median line; on each side of median cleft is a swollen tuberculate prominence which extends caudoventrad and obscures extreme cephalolateral margins of annulus.

*Measurement.*—As follows (in millimeters):

	Holotype	Allotype	Morphotype
Carapace			
height.....	13.9	11.6	12.8
width.....	13.2	11.6	12.1
length.....	32.1	27.6	30.0
Areola			
length.....	7.6	6.3	7.3
width.....	1.9±	1.6	2.2
Rostrum			
length.....	11.4	10.3	10.7
width.....	5.1	4.7	5.1
Abdomen			
length.....	35.6	30.8	32.2
Right chela			
length of inner margin			
of palm.....	10.3	5.1	7.0
width of palm.....	6.0	3.7	4.8
length of outer margin			
of hand.....	25.0	13.5	18.3
length of dactyl.....	12.8	7.1	10.0

*Type locality.*—Talisheek Creek, at Talisheek, St. Tammany Parish, La., a tributary of the

Pearl River. The creek is small (not more than 20 feet wide), spring-fed and sand-bottomed and rises in the longleaf-pine hills a short distance north of Talisheek. Here, for the most part, it is shallow with a few deep holes (4 or 5 feet deep). Vegetation is sparse, but debris collects in the holes and on the lee side of sandbars and behind logs.

The above information was kindly communicated to me by Dr. Penn, who consulted Mr. Viosca, the collector of the type specimens.

*Disposition of types.*—The holotypic male, the allotypic female, and the morphotypic male (nos. 91662, 91663, 91664) together with paratypes consisting of 6 ♂♂ II, 3 ♀♀, 2 ♂♂ immature, and 8 ♀♀ immature from the type locality are deposited in the United States National Museum. A series of paratypes (1 ♂ I, 3 ♂♂ II, 1 ♀, and 1 ♀ immature) collected from a tributary of Black Creek, 7.9 miles west of Hattiesburg, Lamar County, Miss., by Dr. E. C. Raney are in the collection of Dr. George H. Penn, Jr., Tulane University. The following paratypes are in my personal collection at the University of Virginia: HHH no. 3-3048-5a (1 ♂ I, 2 ♂♂ II, 7 ♀♀, 10 ♂♂ immature, and 7 ♀♀ immature) from a tributary of the Pearl River, 8 miles north of Angie, Marion County, Miss., on Route 7 [E. C. Raney, coll.]; HHH no. 6-1549-1 (2 ♂♂ I), 9.6 miles east of Franklinton, Washington Parish, La. [R. D. Suttkus, coll.].

*Range.*—Insofar as is known at present this species is confined to tributaries of the Pearl and Pascagoula Rivers in eastern Louisiana and south-central Mississippi.

*Relationships.*—*Procambarus penni* has its closest affinities with *P. vioscai* but may readily be distinguished from it by the more acute caudal process of the first pleopod of the first form male.

KEY TO THE SPECIES OF THE SPICULIFER GROUP  
(Based on the first-form male)

1. Cephalic process of first pleopod rudimentary or lacking..... *spiculifer*  
Cephalic process of first pleopod well developed..... 2
2. Mesial process of first pleopod terminating proximal of tip of caudal element; rostrum with median carina..... *versutus*  
Mesial process of first pleopod extending beyond tip of caudal element; surface of rostrum concave..... 3
3. Mesial process extending caudolaterad; caudal knob rounded distally in lateral aspect..... *vioscai*  
Mesial process extending caudodistad; caudal knob subacute in lateral aspect..... *penni*

## LITERATURE CITED

- HAGEN, H. *Monograph of the North American Astacidae*. Illustr. Cat. Mus. Comp. Zool. no. 3: 1-109, pls. 1-11. 1870.
- HOBBS, H. H., JR. *The crayfishes of Florida*. Univ. Florida Publ., biol. sci. ser., 3 (2): 1-179, 3 figs., 11 maps, 24 pls. 1942.
- LECONTE, JOHN. *Descriptions of new species of Astacus from Georgia*. Proc. Acad. Nat. Sci., Philadelphia 7: 400-402. 1856.
- PENN, G. H., JR. *A new crawfish of the genus Procambarus from Louisiana (Decapoda, Astacidae)*. Journ. Washington Acad. Sci. 36 (1): 27-29, 1 fig. 1946.

BOTANY.—*A new fern of the genus Danaea from Colombia*.<sup>1</sup> C. V. MORTON, U. S. National Museum.

The small genus *Danaea*, of the family Marattiaceae, is one of the few genera of ferns confined to the Western Hemisphere. It prefers to grow in moist, dark, tropical forests, where it is often one of the most conspicuous terrestrial plants. Because of the lack of clear morphological characters, the species are not well understood. One of the plants collected in Colombia by Kjell von Sneidern represents a new species, described below.

*Danaea tenera* Morton, sp. nov.

Rhizoma crassum, breviter repens, ca. 3.5 cm longum, 1 cm diam.; stipulae magnae, crassae, latae, integrae. Folia sterilia paripinnata, 22-30 cm longa, stipitibus crassis, 8-11 cm longis, 2-4 mm diam., inconspicue 2-nodosis, ubique dense paleaceis, paleis brunneis, minutissimis, suborbicularibus, denticulatis; rhachis compressa, supra nuda, subtus dense et minute brunneo-paleacea, utrinque perspicue viridi-alata, gemma terminata; pinnae tenuiter membranaceae, 12-14-jugae, breviter petiolulatae (1-2 mm), anguste oblongae, 4-6 cm longae, 10-15 mm.

<sup>1</sup>Published by permission of the Secretary of the Smithsonian Institution.

latae, apice gradatim acuminatae, basi obliquae, basi superiore cuneatae, inferiore rotundatae, apicem versus perspicue et argute uncinato-serratae, deorsum paulum undulatae; venae simplices vel plerumque geminae (raro furcatae), 12-14 per cm; lamina supra glabra et paleacea, subtus mesophyllo et praecipue in costis paleacea, paleis valde diversis, alteris mediocribus, orbicularibus vel deltoideis, alteris minutissimis, dissectis vel piliformibus. Folia fertilia ignota.

Type in the U. S. National Herbarium, no. 1742723, collected at La Costa, Department of El Cauca, Colombia, April 1937, in virgin forest, at 1,000 meters elevation, by Kjell von Sneidern (no. 1578).

In its very thin texture *D. tenera* suggests the genus *Trichomanes*, and in this character recalls only *D. crispas* Endres and *D. trichomanoides* Moore. It may be related to the latter, but that species differs (from description) in having smaller, obtuse, merely undulate pinnae; in *D. tenera* the pinnae are long-acuminate and remarkably sharply serrate toward apex. It is not certain whether the leaves of *D. trichomanoides* are abruptly pinnate (as in the present species) or imparipinnate.

## Officers of the Washington Academy of Sciences

*President*.....NATHAN R. SMITH, Plant Industry Station  
*President-elect*.....WALTER RAMBERG, National Bureau of Standards  
*Secretary*.....F. M. DEFANDORF, National Bureau of Standards  
*Treasurer*.....HOWARD S. RAPPLEYE, U. S. Coast and Geodetic Survey  
*Archivist*.....JOHN A. STEVENSON, Plant Industry Station  
*Custodian and Subscription Manager of Publications*  
 HARALD A. REHDER, U. S. National Museum

### *Vice-presidents Representing the Affiliated Societies:*

Philosophical Society of Washington.....EDWARD U. CONDON  
 Anthropological Society of Washington.....WALDO R. WEDEL  
 Biological Society of Washington.....  
 Chemical Society of Washington.....JOSEPH J. FAHEY  
 Entomological Society of Washington.....FREDERICK W. POOS  
 National Geographic Society.....ALEXANDER WETMORE  
 Geological Society of Washington.....LEASON H. ADAMS  
 Medical Society of the District of Columbia.....  
 Columbia Historical Society.....GILBERT GROSVENOR  
 Botanical Society of Washington.....E. H. WALKER  
 Washington Section, Society of American Foresters.....WILLIAM A. DAYTON  
 Washington Society of Engineers.....CLIFFORD A. BETTS  
 Washington Section, American Institute of Electrical Engineers

FRANCIS M. DEFANDORF

Washington Section, American Society of Mechanical Engineers.....RICHARD S. DILL  
 Helminthological Society of Washington.....L. A. SPINDLER  
 Washington Branch, Society of American Bacteriologists.....ANGUS M. GRIFFIN  
 Washington Post, Society of American Military Engineers.....HENRY W. HEMPLE  
 Washington Section, Institute of Radio Engineers.....HERBERT G. DORSEY  
 District of Columbia Section, American Society of Civil Engineers.....

### *Elected Members of the Board of Managers:*

To January 1952.....W. F. FOSHAG, C. L. GAZIN  
 To January 1953.....C. F. W. MUESEBECK\*, A. T. MCPHERSON  
 To January 1954.....SARA E. BRANHAM, MILTON HARRIS\*

*Board of Managers*.....All the above officers plus the Senior Editor

*Board of Editors and Associate Editors*.....[See front cover]

*Executive Committee*.....N. R. SMITH (chairman), WALTER RAMBERG, H. S. RAPPLEYE,  
 J. A. STEVENSON, F. M. DEFANDORF

*Committee on Membership*.....L. A. SPINDLER (chairman), M. S. ANDERSON,  
 MERRILL BERNARD, R. E. BLACKWELDER, R. C. DUNCAN, G. T. FAUST, I. B. HANSEN,  
 D. B. JONES, DOROTHY NICKERSON, F. A. SMITH, HEINZ SPECHT, ALFRED WEISSLER

*Committee on Meetings*.....MARGARET PITTMAN (chairman), NORMAN BEKKEDAHL,  
 W. R. CHAPLINE, D. J. DAVIS, F. B. SCHEETZ, H. W. WELLS

### *Committee on Monographs:*

To January 1952.....J. R. SWALLEN (chairman), PAUL H. OEHSER  
 To January 1953.....R. W. IMLAY, P. W. OMAN  
 To January 1954.....S. F. BLAKE, F. C. KRACEK

*Committee on Awards for Scientific Achievement* (GEORGE P. WALTON, general chairman):

For the Biological Sciences.....G. H. COONS (chairman), J. E. FABER, JR.,  
 MYRNA F. JONES, F. W. POOS, J. R. SWALLEN

For the Engineering Sciences.....R. S. DILL (chairman), ARSHAM AMIRIKIAN,  
 J. W. MCBURNEY, FRANK NEUMANN, A. H. SCOTT

For the Physical Sciences.....G. P. WALTON (chairman), F. S. BRACKETT,  
 G. E. HOLM, C. J. HUMPHREYS, J. H. McMILLEN

For Teaching of Science.....B. D. VAN EVERA (chairman), R. P. BARNES,  
 F. E. FOX, T. KOPPANYI, M. H. MARTIN, A. T. MCPHERSON

*Committee on Grants-in-aid for Research*.....L. E. YOCUM (chairman),  
 M. X. SULLIVAN, H. L. WHITTEMORE

### *Committee on Policy and Planning:*

To January 1952.....J. I. HOFFMAN (chairman), M. A. MASON

To January 1953.....W. A. DAYTON, N. R. SMITH

To January 1954.....H. B. COLLINS, JR., W. W. RUBEY

### *Committee on Encouragement of Science Talent:*

To January 1952.....M. A. MASON (chairman), A. T. MCPHERSON

To January 1953.....A. H. CLARK, F. L. MOHLER

To January 1954.....J. M. CALDWELL, W. L. SCHMITT

*Representative on Council of A. A. A. S.*.....F. M. SETZLER

*Committee of Auditors*.....J. H. MARTIN (chairman), N. F. BRAATEN, W. J. YODEN

*Committee of Tellers*.....W. G. BROMBACHER (chairman), A. R. MERZ, LOUISE M. RUSSELL

\* Appointed by Board to fill vacancy.

## CONTENTS

	Page
MATHEMATICS.—Information theory. CHESTER H. PAGE . . . . .	245
ETHNOLOGY.—Utilization of animals and plants by the Micmac Indians of New Brunswick. FRANK G. SPECK and RALPH W. DEXTER . . . . .	250
PALEONTOLOGY.—New crinoids from the Pitkin of Oklahoma. HARRELL L. STRIMPLE . . . . .	260
ENTOMOLOGY.— <i>Jordanopsylla allredi</i> , a new genus and species of flea from Utah (Siphonaptera). ROBERT TRAUB and VERNON J. TIPTON . . . . .	264
ZOOLOGY.—A luminescent new xystodesmid millipede from California. H. F. LOOMIS and DEMOREST DAVENPORT . . . . .	270
ZOOLOGY.—A new crayfish of the genus <i>Procambarus</i> from Louisiana, with a key to the species of the <i>Spiculifer</i> group. HORTON H. HOBBS, Jr. . . . .	272
BOTANY.—A new fern of the genus <i>Danaea</i> from Colombia. C. V. MORTON . . . . .	276

72W23  
VOL. 41

SEPTEMBER 1951

No. 9

JOURNAL  
OF THE  
WASHINGTON ACADEMY  
OF SCIENCES



BOARD OF EDITORS

CHARLES DRECHSLER  
PLANT INDUSTRY STATION  
BELTSVILLE, MD.

WILLIAM F. FOSHAG  
U. S. NATIONAL MUSEUM

J. P. E. MORRISON  
U. S. NATIONAL MUSEUM

ASSOCIATE EDITORS

J. C. EWERS  
ANTHROPOLOGY

C. W. SABROSKY  
ENTOMOLOGY

F. A. CHACE, JR.  
BIOLOGY

J. I. HOFFMAN  
CHEMISTRY

T. P. THAYER  
GEOLOGY

MIRIAM L. BOMHARD  
BOTANY

R. K. COOK  
PHYSICS AND MATHEMATICS

PUBLISHED MONTHLY

BY THE

WASHINGTON ACADEMY OF SCIENCES  
MOUNT ROYAL & GUILFORD AVES.  
BALTIMORE, MARYLAND

Entered as second class matter under the Act of August 24, 1912, at Baltimore, Md.  
Acceptance for mailing at a special rate of postage provided for in the Act of February 28, 1925.  
Authorized February 17, 1949

## Journal of the Washington Academy of Sciences

This JOURNAL, the official organ of the Washington Academy of Sciences, publishes: (1) Short original papers, written or communicated by members of the Academy; (2) proceedings and programs of meetings of the Academy and affiliated societies; (3) notes of events connected with the scientific life of Washington. The JOURNAL is issued monthly. Volumes correspond to calendar years.

*Manuscripts* may be sent to any member of the Board of Editors. It is urgently requested that contributors consult the latest numbers of the JOURNAL and conform their manuscripts to the usage found there as regards arrangement of title, subheads, synonymies, footnotes, tables, bibliography, legends for illustrations, and other matter. Manuscripts should be typewritten, double-spaced, on good paper. Footnotes should be numbered serially in pencil and submitted on a separate sheet. The editors do not assume responsibility for the ideas expressed by the author, nor can they undertake to correct other than obvious minor errors.

*Illustrations* in excess of the equivalent (in cost) of one full-page halftone are to be paid for by the author.

*Proof.*—In order to facilitate prompt publication one proof will generally be sent to authors in or near Washington. It is urged that manuscript be submitted in final form; the editors will exercise due care in seeing that copy is followed.

*Unusual cost* of foreign, mathematical, and tabular material, as well as alterations made in the proof by the author, may be charged to the author.

*Author's Reprints.*—Reprints will be furnished in accordance with the following schedule of prices (approximate):

Copies	4 pp.	8 pp.	12 pp.	16 pp.	20 pp.	Covers
100	\$3.25	\$6.50	\$ 9.75	\$13.00	\$16.25	\$3.00
200	6.50	13.00	19.50	26.00	32.50	6.00
300	9.75	19.50	29.25	39.00	48.75	9.00
400	13.00	26.00	39.00	52.00	65.00	12.00

*Subscriptions* or requests for the purchase of back numbers or volumes of the JOURNAL or the PROCEEDINGS should be sent to HARALD A. REHDER, Custodian and Subscription Manager of Publications, U. S. National Museum, Washington 25, D. C.

*Subscription Rates* for the JOURNAL.—Per year..... \$7.50

Price of back numbers and volumes:	Per Vol.	Per Number
Vol. 1 to vol. 10, incl.—not available.*	—	—
Vol. 11 to vol. 15, incl. (21 numbers per vol.)	\$10.00	\$0.70
Vol. 16 to vol. 22, incl. (21 numbers per vol.)	8.00	0.60
Vol. 23 to current vol. (12 numbers per vol.)	7.50	0.90

\* Limited number of complete sets of the JOURNAL (vol. 1 to vol. 40, incl.) available for sale to libraries at \$341.00

MONOGRAPH No. 1, "The Parasitic Cuckoos of Africa," by Herbert Friedmann.. \$4.50

PROCEEDINGS, vols. 1-13 (1899-1911) complete.....	\$25.00
Single volumes, unbound.....	2.00
Single numbers.....	.25

*Missing Numbers* will be replaced without charge provided that claim is made to the Treasurer within 30 days after date of following issue.

*Remittances* should be made payable to "Washington Academy of Sciences" and addressed to the Treasurer, H. S. RAPPLEYE, 6712 Fourth Street, N.W., Washington 12, D.C.

*Exchanges.*—The Academy does not exchange its publications for those of other societies.



# JOURNAL OF THE WASHINGTON ACADEMY OF SCIENCES

VOLUME 41

September 1951

No. 9

MEDICINE.—*Disaster and disease.*<sup>1</sup> VICTOR H. HAAS, National Microbiological Institute, National Institutes of Health, Bethesda, Md. (Communicated by Margaret Pittman.)

Accounts of epidemics associated with wars and disasters constitute a major part of recorded history. They form a somber and often mysterious background that frequently overshadows the intermittent brilliance of military and political glory.

In times past, these pestilences seemed pitiless and inescapable. Ignorant and often terrified, men did the very things that promoted the spread and severity of communicable diseases. Modern scientific knowledge has changed this situation: epidemics can be faced in an orderly manner; their dangers can be assessed from the sound basis of proved facts; specific measures to limit their threat can be taken with confidence.

Properly interpreted, the lessons of the past can give us confidence to meet the challenge of another world war capable of imposing catastrophe beyond anything heretofore known in history. So far as disease is concerned, we can expect to survive even the shambles of an atomic war if we use our knowledge and our resources properly. But we shall have to exert ourselves to do it; we cannot take it for granted.

## EPIDEMICS OF ANCIENT TIMES

Medical historians have long been fascinated and somewhat puzzled by a Biblical account of an epidemic following a military campaign. In I Samuel, it is told how the Philistines overcame the Jews and carried off their sacred Ark. This act so angered Jehovah that "He smote the men of the city, both small and great, and they had emerods in their secret parts . . . the hand of

God was very heavy there. And the men that died not were smitten with the emerods."

The difficulty in understanding just what happened to the Philistines is that—as one historian puts it—"the Lord only knows what an emerodis" (*1*). Etymologically it is a hemorrhoid, but—as this same writer puts it—"it is hardly likely that even the Philistines could have had a fatal epidemic of hemorrhoids." Omitting the learned dissertations that have developed around this puzzling term, we may say that all medical historians come out with the conclusion that what Jehovah had dealt out to the Philistines was probably an epidemic of bubonic plague.

This uncertainty as to the exact identity of ancient pestilences is a prominent feature of medical history. The "plague of Athens" recorded by Thucydides is an example of this confusion. In 430 B.C. the Peloponnesians were attacking the cities of Attica, and the refugees from the hinterlands swarmed into Athens, which became greatly overcrowded. Suddenly a disease struck the city: "Athenian life was completely demoralized . . . there was no fear of the laws of God or man" (*1*). The Peloponnesians were so afraid of the disease that they withdrew from Attica. At the same time, Athenian naval action against the Peloponnesians was frustrated by the epidemic in the fleet. No one knows what this epidemic, which undoubtedly had an important role in Greek history, really was, or whether it represented one disease or several. In the second year of the epidemic more than 55,000 Athenians were said to have died of it, including Pericles himself.

<sup>1</sup> Address presented before the Washington Academy of Sciences, April 19, 1951.

In the time of Marcus Aurelius there was an epidemic that appears to have resembled in many respects the plague of Athens. This is known as the "plague of Antoninus"; it began in A.D. 165 in the Roman army of Verus, in the East. The army scattered the disease; it eventually spread over the entire Roman world, lasting 14 years. In Italy cities and villages were abandoned and fell into ruin; in A.D. 169, Roman armies campaigning against the Germanic tribes found many of the barbarians dead on the field from the epidemic. Marcus Aurelius died of it, too.

The great "plague of Cyprian" fell upon the whole known world in A.D. 250—Roman and barbarian alike. This epidemic (again its identity is uncertain) was spread by the active warfare of the time. According to one historian "men crowded into the larger cities; only the nearest fields were cultivated; the more distant ones became overgrown . . . farm land had no value" (1). A contemporary writer said the human race had been "all but destroyed" (1); the earth was returning to desert and forest. It is claimed that Christianity got a good start as a result of this pandemic, because of the great popularity of St. Cyprian as an exorciser of evil spirits.

Disaster and disease swept the Roman world for centuries: earthquakes, floods, wars, famine, and epidemics. The greatest of all pandemics of those times was the "plague of Justinian." It followed a succession of disasters, such as the earthquake that destroyed Antioch, killing more than 200,000 persons.

This "plague of Justinian" began in A.D. 540. According to a contemporary writer, "it spread over the entire earth and afflicted all without mercy . . . it spared no habitations of men, however remote" (1). The paramount historian of Rome, Gibbon, says that "no facts have been preserved to sustain an account or even a conjecture of the numbers that perished in this extraordinary mortality. I only find that, during three months, five and at length ten thousand persons died each day at Constantinople; and many cities of the East were left vacant, and that in several districts of Italy the harvest and the vintage withered on the ground. The triple scourges of war, pestilence, and famine

afflicted the subjects of Justinian; and his reign is disgraced by a visible decrease of the human species which has never been regained in some of the fairest countries of the globe" (1).

The plague of Justinian lasted from 540 until 590. During this time, Italy was conquered by the Lombards; a contemporary writer said they "resemble in figure and in smell the mares of the Sarmatian plains" (1).

This pandemic is believed by many to have been bubonic plague, though some descriptions of the time are considered suggestive of smallpox.

#### PLAGUE

The most devastating epidemic recorded in history was certainly one of bubonic plague: the "Black Death," which occurred exactly 600 years ago. This terrible affliction owed its inception to war. In 1346 the Tartars besieging the Don Cossacks in the Crimea were attacked by plague that is supposed to have been indigenous in the native rodents of the region. From them it spread to the besieged populations, and thence to China and India on one hand, and to Europe and Africa on the other. This was a true pandemic: an outbreak of disease that spread over most of the old world. It overran Europe from 1348 to 1352. It has been conjectured that 13,000,000 Chinese died of the Black Death. The population of England is estimated to have fallen from about 5 million to 2½ million. Somewhere from one-fourth to three-fourths of the population of Europe is said to have died in the three years beginning in 1348 (2).

For three centuries following the Black Death, plague smoldered in London, to break out into a furious epidemic in 1665. The population of London had suffered an unusually severe winter; plague began in the slums as winter ended. In this one year, it is believed to have killed nearly 110,000 out of London's 460,000 population. Defoe said, "London might well be said to be all in tears . . . The shrieks of women and children at the windows and doors of their houses, where their dearest relatives were perhaps dying, or just dead, were so frequent to be heard as we passed the streets, that it was

enough to pierce the stoutest heart in the world to hear them . . . Whole families, and indeed whole streets of families, were swept away together" (2).

Following this epidemic, plague disappeared from England and was not seen there again for nearly two and a half centuries. In Continental Europe, however, there were two major epidemics—one in 1770 and one in 1826. Both were generated by wars between Russia and Turkey. The first of these outbreaks is said to have caused 300,000 deaths in Hungary, the Ukraine, and Poland, and 50,000 deaths in Moscow—more than one-fourth of the population. The second epidemic killed 4,000 persons in three months in the city of Varna.

The last pandemic of plague began in southwest China about 1894. Reaching Bombay in 1896, it spread over India and by 1904 was responsible for 1,000,000 deaths annually in that country. Within six years every continent had become infected from this outbreak; in 1900 the disease was recognized in North America for the first time in history. Some writers refer to the situation now existing as the "present pandemic of plague," for the disease still lingers in many parts of the world to which it came with the great recrudescence around the beginning of the present century.

But there was only one Black Death.

#### TYPHUS

The disease most frequently associated with war is typhus. Hirsch says, "The history of typhus is written in those dark pages of the world's story which tell of the grievous visitations of mankind by war, famine, and misery of every kind" (3).

The role of this specific disease in earlier times is obscure. It has been suggested that the epidemic that destroyed the army of Frederick Barbarossa in 1157 might have been typhus. Four days after the disease struck, the army, which had occupied Rome, abandoned the city and departed northward; the greater part of them died on the march.

Perhaps the first clear instance of a decisive role played by typhus in war occurred in 1566. An epidemic, quite evidently of this disease, broke out in the German army of Maximilian II, who was forced to abandon

his entire campaign against the Turks in Hungary. This epidemic, called at the time "morbus hungaricus," spread over Austria, Germany, the Netherlands, and Italy, carried by returning troops.

The 30-years' war (1618–1648) was dominated by pestilence, of which typhus was a major cause. One historian says, "The sufferings of the German people during these thirty years are beyond telling" (1). When both plague and typhus struck, "in some villages the populations perished en masse . . . half the inhabitants of Munich died in 1634 . . . the population (of Germany) decreased by more than one-half" (1).

In 1632, at Nuremberg, typhus and scurvy together killed 18,000 soldiers, and the opposing armies of Gustavus Adolphus and Wallenstein left the field without battle.

Throughout the eighteenth century wars were followed by typhus. Hirsch says of this time, "As the oppression of war spared no country in Europe . . . so did the pestilence of war, particularly typhus, following at the heels of the conquerors and the conquered, spread all over Europe and rise to a terrible height in those places where the visitation of war had been most severe . . . in the universal distress caused by the war (it had) a very favorable soil in which to flourish" (3).

Of the many misfortunes that befell Napoleon's army in the Russian campaign, none had more effect than disease, particularly typhus. On the march to Moscow in 1812 the French were infected at Vilna; by the time the retreat had begun there was so much sickness in the Army that thousands had to be abandoned. "French soldiers . . . spread the contagion (typhus) over a large part of Central Europe. Almost naked . . . they marched through Poland and Germany. Typhus and other diseases associated with it marked their course. The inhabitants of the country were forced to house the sick; but teamsters also conveyed the infection to villages which the soldiers did not visit" (1).

"The number of persons who succumbed to typhus in Germany during the years 1813–1814 must be estimated at least as high as 200,000 or 300,000 . . . the number that contracted it would amount to 2,000,000," according to Prinzing (1). This would be

about 10 percent of the total German population.

Typhus was widespread among troops in the Crimean War (1854-1856), but there was no great amount of troop movement in this campaign, and civilian outbreaks did not develop. The troops in Crimea were severely stricken with an almost unprecedented variety of diseases, including—in addition to typhus—cholera and dysentery. In 1855, there were 48,000 casualties from sickness in 4 months. For the whole war—all armies—there were about 63,000 deaths from battle, compared with 104,000 from disease.

The greatest typhus epidemic of record accompanied World War I on the southern and eastern fronts. In 1915, about 120,000 Serbs died between January and March, out of a population of 4,000,000. In 1920, there were more than 3 million cases of typhus reported in Russia, and as many cases of relapsing fever. Between 1917 and 1923, there are believed to have been 30,000,000 cases of typhus in Russia, and 3 million deaths.

All of this was brought about by war, revolution, famine, and the wanderings of homeless, unsupervised refugees, followed by movements of troops during the civil wars of 1919-1920.

#### SMALLPOX

Another epidemic disease that has appeared in military history is smallpox. Some believe that it may have been responsible for the plagues of Athens and of Justinian. Many medical historians seem agreed that smallpox was absent from Greece and Rome during most of the classical period. It is supposed to have reached the middle east from Ethiopia in the fourth century A.D., during what was called the "Elephant War," and to have been carried into Spain by the Saracens, spreading thus over Europe. It had permeated Europe by A.D. 1000 and was repeatedly reintroduced by the Crusaders, and later by the Mongolians.

Smallpox is supposed to have facilitated conquest of the New World by the Spaniards: a Negro from a ship of Narváz carried it ashore and over 3,000,000 Indians eventually succumbed.

"The most furious epidemic of the 19th century" (4) was one of smallpox generated

by the Franco-Prussian war of 1870-1871. At that time Germany was almost free from smallpox, but it was epidemic in Paris and elsewhere in France. Thousands of French prisoners, scattered throughout Germany, disseminated the disease which was then "conveyed from place to place . . . by the moving population itself, . . . by marching troops, and . . . by the removal of prisoners from one place of detention to another." From 1870-1874 there were 140,000 smallpox deaths in Prussia; in France 200,000 deaths in 2 years; in England 43,000 in the same period. In Austria 167,000 died in 6 years. The epidemic reached Scandinavia, Italy, and North America. "But the further the disease was removed from the seat of war the easier it was to control" (4).

#### DYSENTERY AND TYPHOID

Dysentery and typhoid have been associated with wars of recent times. Napoleon's troops spread dysentery over Europe. In the American Civil War the diarrheal diseases—called "alvine fluxes" (5) by the medical writers of the time—accounted for 1,700,000 casualties and 45,000 deaths in the Union Armies, compared with 44,000 killed in battle and 49,000 dying of wounds. "No district in which troops were massed for war purposes was exempt from the scourge" (5).

In the Spanish-American war (1898) typhoid caused more casualties (20,904 cases, 2,188 deaths) than military action, and in the Boer War (1899-1902) it was a major problem. But though "troops in war time have suffered heavily from enteric fever (typhoid) the evidence of its introduction by them into civilian populations is small" (4).

#### CHOLERA

Another of the great pandemic diseases, cholera, "is much more involved with pilgrimages than the movements of armies" (4). In India, which is the endemic home of cholera, it is spread by festivals and fairs; its importation to the West in times past has often been initiated by Muslim pilgrimages to Mecca. There are said to have been six pandemics of cholera in the past century or so. In four of these cholera reached the United States, the last time in 1911.

In 1833 it struck New York. A physician of the time said, "Our citizens had heard and read so much of this Asiatic scourge, and all we knew of it had impressed us with a sense of its mysterious character, its rapid and erratic course, its unmanageable and incurable nature, and its certain and dreadful fatality. Its fearful devastation in India and elsewhere had filled the mind with horror at the bare recital of its ravages, and the rumor of its appearance on the shores of the St. Lawrence threw our population into consternation . . . which, in some instances, became so intense as to dethrone reason itself and impel to suicide" (2). In 1849 cholera crossed the continent with the emigrant wagons, and in 1850 half the population of Sacramento fled from it; one-fourth of those who remained died.

#### YELLOW FEVER

Yellow fever is not usually associated with war and disaster. It has tended to spread with peaceful commerce. But in one instance it played a critical part in military action. In 1801 Napoleon sent Leclerc with 25,000 French troops to Haiti to suppress the revolt. After defeating the Haitian Army, the French were struck by yellow fever. Of the Army of 25,000 Frenchmen, 22,000 died. In 1803 there were only 3,000 left to evacuate the Island.

#### SYPHILIS

The spread of syphilis over Europe appears to have been the result of a specific military campaign. In 1494 Charles VIII of France invaded Italy and occupied Naples. The city was defended by Spanish soldiers, and it is believed that the latter had brought syphilis to the Neapolitan women. Charles's soldiery ran wild through the city, and contracted the disease. Then the invaders withdrew and scattered over Europe. Wherever they went, syphilis appeared: France, Germany, England, Scotland, Russia—even to far-off China, and Africa. Why did it spread in such sudden and dramatic fashion? Perhaps we shall never know entirely, but two important factors were:

1. It was a time of great floods, drouth, and excessive heat. Plague, ergot poisoning,

and other illnesses had decimated the population and weakened resistance.

2. It was a period of unprecedented licentiousness. Says Hirsch: "The corruption of morals had at the time reached a height which even contemporary writers tell us was without parallel in ancient times" (3).

#### INFLUENZA

The greatest pandemic of modern times was that of influenza in 1918-19. "While all Christendom bent its energies to the killing of young men, nature outstripped the statesmen: influenza killed more victims in a few months than all the armies in 4 years" (2). In the United States there were 20 million cases and around a quarter of a million deaths. "In India 6 months of influenza accounted for nearly as many deaths as 20 years of cholera" (2). It is estimated that there were 200 million cases in the world, and more than 10 million deaths. "The pandemic of 1918 and 1919 ranks with the plague of Justinian and the Black Death as one of the 3 most destructive outbreaks of disease that the human race has known" (2).

"Yet we are struck by the absence, in 1918, of the degree of panic and desolation which is reported for comparable waves of death in earlier years . . . it seems that human composure was not so shaken by this disaster as it had often been before by those of smaller compass . . . disease was no longer so mysterious, so portentous an experience as it had once been. After a generation of research, infection was comprehensible, even though this particular infection still proved baffling" (2).

In the United States "one person in every 4 fell sick. . . . The Black Death killed 9 out of 10 whom it attacked, cholera sometimes 4 out of 5; influenza in 1918, only 2 or 3 out of a hundred" (2).

#### WORLD WAR II

These brief glimpses of medical history illustrate the importance of disease—particularly communicable disease—in the development of civilization. They show how epidemics are generated by wars and by the disastrous conditions which accompany and follow wars.

The greatest war of all time is still fresh in our memory. And one of the most amazing features of this war is the fact that, catastrophic as it was, beyond anything known to history, it produced no major epidemics.

World War II was distinguished by all the conditions which appear to have facilitated the dissemination of epidemics in all previous major wars, such as:

1. Movements of great bodies of troops over long distances. In World War II there was constant interchange of troops among all the major regions of the earth. They passed through or sojourned in areas where such diseases as plague, cholera, yellow fever, and smallpox were prevalent.
2. Displacement of civil populations, with great masses of wandering, homeless refugees. This occurred in the Orient and in Eastern Europe—both regions where epidemic diseases are indigenous—as well as in the relatively healthier countries of the West.
3. Breakdown of civil authority, with consequent failure to maintain the sanitary practices of normal times.
4. Tremendous destruction of cities, with disruption of water supplies, sewage systems, food sanitation, and the like—all because of irreplaceable losses in plant and equipment.

The "epidemic potential" must have been high. There were indeed numerous epidemics of circumscribed extent. Plague broke out several times in North Africa; there was a serious epidemic of typhus in Italy, centering around Naples; cholera caused our military authorities some concern in the Orient. Smallpox repeatedly presented a challenge: it got out of hand for a time in Japan, and spread to the United States and to England among returning troops. Hundreds of thousands of soldiers acquired malaria, bacillary dysentery, and amebiasis. There were a number of outbreaks of infectious jaundice. Diseases like "mite typhus" and filariasis were important military medical problems.

But there were no pandemics, nor threats of any.

The explanation for this failure of epidemics to get out of control in World War II relates to our modern knowledge of the

factors which favor the dissemination of specific communicable diseases, and our ability—because of such knowledge—to alter these factors to our advantage.

At the time of World War I we understood a great deal about the method of spread of epidemics, and could control most of them, but our methods were either cumbersome or not efficient. Between World Wars I and II, and during World War II, there were many improvements in knowledge and resources:

1. The sulfonamide drugs and the antibiotics for treatment of many communicable diseases (e.g., plague, dysentery).
2. D.D.T. for the control of vermin (e.g., lice, fleas).
3. Better and more accurate methods of diagnosis (e.g., extension of the complement fixation test, advances in virology).
4. Better vaccines, to provide more reliable immunity (e.g., yellow fever, typhus).

#### PRESENT PROSPECTS FOR EPIDEMIC CONTROL

Since World War II, even more advances have been made. There are several new antibiotics (such as chloramphenicol and aureomycin) that give us the upper hand over many more diseases than we ever had before. There are new rat poisons, important in reducing the hazard of plague. The virus that causes influenza, unknown during the pandemic in 1918, has been studied with increasing thoroughness, and better vaccines are being developed. Better methods of water purification appear possible, not that we need any safer water than we have now in our cities; but these methods might be more adaptable to emergencies.

If there should be a World War III, we all know that it would be terrible. We expect that our cities would suffer enormous destruction. Water supplies, sewage systems, and other sanitary mechanisms would be destroyed or disrupted for long periods. Hospitals would be jammed with casualties, as indeed would many other buildings which would have to be converted to shelter the injured. Medical and allied professional people would be tremendously burdened. Civil authority would have to exert its utmost effort to meet such catastrophes. Un-

der such conditions, what must we expect in regard to epidemics?

My answer is that we would have epidemics. We always have them. They are going on right now. There was an epidemic of influenza last winter—several of them if you care to look at it with great exactitude. There will be epidemics of poliomyelitis this summer. In India there will probably be epidemics of cholera in a month or so—there always are. There will be outbreaks of yellow fever in South America this year, as there have been at intervals for generations. There was a case of bubonic plague in New Mexico in January; last year there were five cases in the United States as a whole. (In 1925 there was an epidemic of pneumonic form of plague in Los Angeles, and 33 people died of it.)

During the past four years there have been apprehended at various quarantine stations 8 ships infected with cholera, 88 with smallpox, and 1 with plague.

Epidemics of such diseases as influenza, cholera, plague, and typhus and outbreaks of yellow fever and smallpox scarcely come to the notice of the general population nowadays, although there is no attempt to conceal them. Indeed, there is rapid exchange of such information all over the world (6, 7). But since the outbreaks either do not get out of hand or, if they do, are brought under control with confidence and dispatch, the general public is not too concerned about them.

If war should come, outbreaks of this sort would have to be regarded with more concern than they merit in times of peace. We should have to take them quite seriously and apply our knowledge and our resources as quickly and thoroughly as possible to bring them under control or to keep them from getting out of hand.

The important point is that we do have the knowledge to make it possible to do this. To the extent that our physical plant is damaged, and our supplies of medicines, vaccines, insecticides, and the like may be destroyed, it will be more difficult to apply that knowledge. But no matter how many difficulties of this sort may develop, we still have the knowledge—which is where we differ basically and completely from our

predecessors of earlier times, who had recourse only to guesswork, superstition, and flight.

We do not expect to escape any war without suffering and death. That is the price of war. Part of that price will be paid in increased communicable diseases, in epidemics, and in deaths from epidemics. We must face this, just as we must face the appalling destruction that would come from atom bombs.

Why not hedge against this danger of disease by immunizing everyone in advance? We can vaccinate against influenza, cholera, plague, typhus, and so on. The Armed Forces are immunized against quite a variety of diseases, as everyone remembers who has stood in line for "shots."

But what we need to meet the threat of atomic war is careful judgment, based on assessment of all the factors—not rule-of-thumb, or an "easy way out."

To immunize 150,000,000 people against all the diseases for which we have vaccines would consume tremendous resources in terms of manufacturing capacity, trained personnel to administer the injections, maintenance of records, and general administrative arrangements. Even were we willing to make such a commitment, many of our immunizations could not be relied upon to protect every person inoculated. And since nearly all give only temporary protection, they would have to be repeated—for who knows how many times?

This does not mean that all immunizations are impractical—far from it. Speaking only for myself, I believe that we should immunize as many people as possible against smallpox and try to keep them immunized. I also feel that we should immunize all children against diphtheria, whooping cough, and tetanus. But this is nothing new at all; it is part of our regular peacetime public-health program. In addition, I think that if war is anticipated we ought to immunize everyone who is likely to be in a target area against tetanus.

That is as far as I should go in immunizing the population generally. Beyond that, I should rely on our scientific knowledge, our medicines and chemicals, and our judgment, to pull us through. We can boil

our water if we have to, or put tablets of disinfectant in it. We can bury our excreta and food wastes. We can treat patients with drugs and antibiotics to reduce reservoirs of infection. We can attack insects and rodents with established methods.

Above all, I believe we should diligently encourage research. We must base our plans for defense upon the most thorough consideration of the knowledge we have; meanwhile we must continue with utmost vigor to increase and improve our knowledge and understanding.

#### BIOLOGICAL WARFARE

We have been told that another war might bring into use a new weapon—one never before tried—biological warfare. This means the intentional use of disease-producing microorganisms or their products to cause casualties in a target population. We must consider this possibility in our plans for defense. Biological warfare may never be used, but if it is we want to be ready to defend ourselves.

The same principles that apply to control or prevention of diseases of natural origin apply to defense against biological warfare. Our knowledge of the biology of disease, our medicines and techniques, and our experience in public-health operations will be brought to bear on any problem that might arise in this manner, and we can expect them to be effective.

If biological warfare is used against us, it may be anticipated that the agents employed will be those we meet in regular public-health practice. It is not expected that strange new organisms would be employed, or that mysterious or unpredictable outbreaks of disease would be produced. In fact, most of the organisms that would appear to possess the qualifications that one would regard as essential for use in biological warfare would not spread from person to person. Self-perpetuating epidemics would be most unlikely. It is well to remember that

it has never been shown that an epidemic could be started intentionally. In fact, it is not known just how or why an epidemic starts or fails to start in nature. Greenwood says, "In plague, as in other sicknesses, something more is needed to generate an epidemic than even widespread and quite uncontrolled means of infection" (4).

What has been said about disease arising from atomic disaster applies to the possibility of biological warfare. We would expect casualties—and deaths—but we would also expect to be able to bring the situation under control. In regard to immunization, the same principles would apply as for atomic warfare and general disaster. For biological warfare, we might consider broadening a bit the scope of immunization, but only on the basis of careful assessment of all the factors—not an over-all procedure to provide what might superficially appear to be an easy answer.

#### REFERENCES

Statistics have been compiled from the sources given below, but only direct quotations are specifically documented. Extensive bibliographies and basic references are contained in the sources listed here.

- (1) ZINSSER, HANS. *Rats, lice, and history*. Boston, 1935.
- (2) SMITH, GEDDES. *Plague on us*. The Commonwealth Fund, New York, 1941.
- (3) HIRSCH, AUGUST. *Handbook of geographical and historical pathology*. (Translated from the German by Charles Creighton.) The New Sydenham Society, London, 1883.
- (4) STALLYBRASS, C. O. *The principles of epidemiology*. New York, 1931.
- (5) BARNES, JOSEPH K. (Surgeon General, U. S. Army). *The medical and surgical history of the War of the Rebellion (1861-1865)*. Washington, 1870.
- (6) U. S. PUBLIC HEALTH SERVICE: National Office of Vital Statistics. *Weekly Communicable Disease Summary*. Washington, D. C.
- (7) WORLD HEALTH ORGANIZATION: Regional Office. *Weekly Epidemiological Report*. Washington, D. C.
- (8) ROSENAU, MILTON J. *Preventive medicine and hygiene*, ed. 6. New York, 1935.



ETHNOLOGY.—*Medicinal plants used by Choctaw, Chickasaw, and Creek Indians in the early nineteenth century.* T. N. CAMPBELL, University of Texas. (Communicated by Frank H. H. Roberts, Jr.)

What is known today about medicinal plants used by the Indians of the Southeastern United States is based largely on information accumulated by ethnologists within the present century. Most of this has been summarized by Taylor (1940), who has compiled data on 185 plants used by eight Southeastern groups—Cherokee, Catawba, Creek, Alabama, Koasati, Chickasaw, Choctaw, and Natchez. The literature on these Indians prior to the period of enforced removal (circa 1830–1850) contains very little specific information on medical ethnobotany. For this reason the material presented below is of special interest. It was obtained by Gideon Lincecum, a self-taught physician and naturalist, from Choctaw, Chickasaw, and Creek Indians in the States of Mississippi and Georgia during the years 1800–1835. It is a partial but acceptable record of medicinal plants used by these three Indian groups in the early nineteenth century. The comparatively early date of this record makes it possible to note changes that have taken place in the herbal medicine of these Indian groups over a period of approximately one hundred years.

The names and medicinal uses of the plants presented on the following pages have been taken from Lincecum's medical herbarium of plants native to the Southeastern United States. This herbarium, which consists of 305 pressed plants, is now in the possession of the University of Texas Library in Austin. The plants were collected by Lincecum in eastern Mississippi and southeastern Texas over a long period of time, but principally between the years 1830 and 1868. On the outside of each folder, in Lincecum's handwriting, is the scientific name of the plant, the English name or names, occasionally an Indian name, along with data on the part or parts of the plant used for medicinal purposes, the method of preparation, the medicinal properties (based on Lincecum's own clinical observations), and the disease for which the prepared drug was used in Lincecum's practice. Twenty-two of the folders include miscellaneous remarks on

the medical use of the enclosed plants by Choctaw, Chickasaw, and Creek Indians. The plants from these 22 folders have been examined and identified by Dr. Benjamin C. Tharp, Department of Botany, University of Texas, whose assistance is gratefully acknowledged.

Published biographic materials afford some basis for evaluating the reliability of Lincecum's ethnobotanical notes. (Geiser, 1948, pp. 199–214; Lincecum, 1904a) Lincecum was not medically trained in the orthodox manner of his day, i.e., by study at a medical college or with a licensed practitioner. He learned medicine by reading medical literature. He learned systematic botany in the same way, and it is of interest to note that the specimens in his herbarium are, with few exceptions, accurately classified for his time. This lack of formal training probably explains some of Lincecum's readiness to adopt Indian herbalism.

Of more importance is the biographic evidence of close association with the three Indian peoples in question. The first 25 years of Lincecum's life (1793–1818) were spent on the outer fringe of the Georgia frontier, where he had ample opportunity to observe the Creek Indians. For a period of 30 years (1818–1848) he lived in eastern Mississippi near the present town of Columbus. Until the period of removal, this was near the boundary that separated the Choctaw and the Chickasaw. For several years Lincecum operated two trading posts, one patronized principally by the Choctaw, the other by the Chickasaw. He spoke the languages of both groups. During the early 1820's he recorded—in the Choctaw language, using the Roman alphabet and various diacritical marks—a long traditional history of the Choctaw as related by an old and learned Choctaw man. A translation of this survives and a portion of it has been published (Lincecum, 1904b).

It is very clear from his autobiography that Gideon Lincecum had a detailed knowledge of Choctaw medicinal plants. In the early 1830's, having lost a number of pa-

tients, he became dissatisfied with the medicines he was using and decided to investigate Choctaw herbal medicine. He got in touch with the leading doctor (*alikchi chito*, "big doctor") of the Southern or Six-towns group of Choctaw. This Indian doctor was evidently much disturbed by the advanced stage of Choctaw acculturation at that time, for he sent word to Lincecum that he would be "willing to teach what he knew about medicine before he died to somebody, and to a white man in preference to his own people, because the white man would place it on paper and preserve it" (*ibid.*, 1904a, p. 494). The pay for his services as an informant was to be 50 cents a day and his food.

The Choctaw doctor met Lincecum at a certain bluff on the Noxubee River, and the two men lived in the woods for six weeks. The Choctaw collected plants alone during the day, and in the evening before a fire "he unrolled his specimens of medicinal plants and laid them in order on his right hand where he was sitting. He then took them up, one by one, described the kind of soil they were found in, their use, the season to collect them and what other plants they were sometimes combined with" (*ibid.*, pp. 495-496). Using his system for recording Choctaw, Lincecum wrote down everything that the doctor told him, and he also preserved small specimens of each plant. At the close of the 6-week period the doctor had Lincecum read back to him everything that he had dictated. At this time errors were corrected and additions made.

Unfortunately this remarkable record of Choctaw medicinal plants does not seem to have survived. It is not among the Lincecum manuscripts in the University of Texas Library, and the living descendants of Lincecum do not know of it. Nothing remains but the scattered remarks in Lincecum's medical herbarium. Undoubtedly many other plants in the herbarium were used by the Choctaw, but the present record does not permit them to be specified.

In the sections that follow only such passages have been taken from Lincecum's herbarial notes as seem to be pertinent to Indian medicinal usage. Lincecum's statements are enclosed in quotation marks.

When Lincecum gives Chickasaw or Choctaw names, the nearest equivalents in Byington's Choctaw dictionary (Byington, 1915) have been inserted in brackets. Aside from simplifying the spelling of a few words, such as "Chocktaw" and "Chickesaw," no further editorial changes have been made.

#### CHOCTAW

Cushman (1899, pp. 228-229) has given the English names of seven medicinal plants used by the Mississippi Choctaw, presumably in the middle of the nineteenth century. Fifty-three medicinal plants have been reported in the literature of the current century. From the Choctaw of Bayou Lacomb in southeastern Louisiana Bushnell (1909, pp. 23-24) collected 25 plants in 1909. All these are identified by scientific name as well as by Choctaw name, and only one appears on Cushman's earlier list (its use is not given by Cushman). About 1918 Swanton (1931, pp. 237-238) obtained a list of 12 medicinal plants from a Choctaw informant in eastern Mississippi. These plants are identified only by Choctaw and English names, but they do not appear to duplicate any plants on the Cushman and Bushnell lists. Taylor (1940, *passim*) does not make use of the Cushman and Swanton lists, but she incorporates the Bushnell list of 25, to which are added plants collected in her own field work among the Choctaw in the 1930's. She does not state whether her field work was done among the Mississippi or the Louisiana Choctaw. Her contribution to Choctaw medical ethnobotany consists of new uses for six plants on the Bushnell list and 16 plants previously unreported from any Choctaw group. To this may be added the Lincecum record, which provides data on 16 plants used by the Choctaw early in the nineteenth century:

*Polygonum aviculare* L., deerweed, knotgrass, pinkweed. "Whole plant. A strong tea of this plant drunk freely, is the Choctaw remedy to prevent abortion. They have the utmost confidence in its powers; they all know it, and consequently abortion is a circumstance of very uncommon occurrence."

*Heuchera americana* L., alum root, rock geranium. "The root. Astringent, tonic. This is a

valuable remedial agent, useful in all cases requiring powerful astringents; it has been noticed and used by all the different aboriginal tribes with whom I have become acquainted in the South [Choctaw, Chickasaw, and Creek]."

*Tephrosia elegans* Nutt. Linceum does not link this plant with any specific Indian group, but in view of certain remarks in his autobiography it is most likely of Choctaw origin. "The root of this plant is an excellent article in bad coughs. The method of using it, is, to carry it about you, and chew it frequently through the day, swallowing juice. If the bowels become loose, you have swallowed a little too much; diminish the quantity so as to properly regulate the bowels, and continue its use for a long time. This is an Indian remedy. . ."

*Geraneum maculatum* L., spotted crane's-bill. "Root. Powerful astringent. The Choctaws consider it as the most effectual of their remedies for the cure of the venereal."

*Vitis aestivalis* Michx., summer grape. "Refrigerant, tonic, acid. I was witness to a case while I resided with the Choctaw Indians, which to me was very singular. There was a woman between 14 and 15 years of age, who died in childbed, leaving her infant child to the care of its grandmother. This old woman was 55 years of age when she took the child, and had not nursed a child since the mother of the infant in question was weaned. She took the infant and as is the custom with Indian women, she cried and grieved over it, sympathizing with and strongly desiring that she might give nourishment to it, and be able to raise up the infant to fill the place of its deceased mother; and all the time, as often as five or six times a day she washed her breast with and drank freely of the water of the grape vine. The result was that in the course of a week she began to secrete milk, and very soon her breasts were full and plump, and she nourished the child sufficiently to keep it healthy and fat. She told me that it was the custom of her country women."

*Sida hederacea* Torr., round-leaved sida. "Choctaw name: *Shaka oakheesh* [probably *sheki*, buzzard; *okhi*<sup>sh</sup>, medicine]. The root. Mucilaginous. It is used by the Choctaws in dysentery, diarrhea, inflammation of the bowels, burns, etc. The root when dried is easily pulverized. . . " The Choctaw, like the Creek and Chickasaw, believed that many diseases were caused by animals. (Sawnton, 1931, pp. 235, 237). *Sheki okhi*<sup>sh</sup>, "buzzard medicine", may indicate that certain intestinal disorders were ascribed to this bird. For reference to an-

other animal, the fox, see *Eryngium aquaticum* below.

*Alalia racemosa* L., American spikenard, Indianroot. "Choctaw name: *tally thla,po,la* [possibly *tala*, name of a certain root; *lopoli* to pass through slowly]. The berries, the root. Stimulant, expectorant. The Choctaws use it for many complaints among their children. In all cases where we use paregoric, Bateman's drops, Godfrey's cordial, etc., they use the spikenard. . . For this purpose they boil a little of the root in clear water, sweeten the decoction, and give it pretty freely to children of any age, who are troubled with gripes, colic, etc. . . In bad cases of putrid sore eyes, the Choctaws boil up a quantity of the root, and while it is boiling, hot-steam their eyes over it. Two or three applications generally cure them."

*Eryngium aquaticum* L., bitter snakeroot, rattlesnake master. "Choctaw name: *Pis, hok, chu, la* [*pishuk*, name of a weed used in dying red; *chula*, fox]. The root. Powerful diuretic, expectorant, stimulant, and anti-poison—good for snakebite. The Choctaw cure gonorrhoea with this plant."

*Asclepias verticillata* L., milkweed. "The root. Sudorific, stimulating. The Choctaws esteemed it among their most valuable remedies for snakebite. They administered it in strong decoction, and chewed the root, swallowing the saliva while chewing."

*Cephalanthus occidentalis* L., buttonbush. "Bark of the root and of the tree. Tonic, febrifuge. A strong decoction of the bark of the tree is a favorite medicine with the Choctaw Indians for dysentery."

*Galium asprellum* Michx., bedstraw. "Whole plant. Diaphoretic, diuretic. The Choctaw cure measles with it—and go in the rain, water, and cold all the time."

*Galium boreale* L., bedstraw. "Choctaw name: *Ahoyo oakheesh* [*ohoyo*, woman; *okhi*<sup>sh</sup>, medicine]. The whole plant. Diuretic, diaphoretic, and deobstruant. This is the article [decoction made from the whole plant] used by the Choctaw women for the purpose of preventing impregnation. They told me that it proved uniformly successful, without injuring the health! I have abundant testimony of this statement."

*Galium uniflorum*, Michx., bedstraw. "Whole plant. Astringent, good dye weed. The Choctaws made frequent use of this family of plants, in all cases requiring diuretic, and diaphoretic action."

*Nabalus asper* (Michx.) T & G, rough white lettuce. "Secernant, stimulant, anodyne. Elect-chee Chitto [Alikchi Chito], the Six Town doctor, used a decoction of the roots and tops of this plant as a stimulating diuretic and anodyne, taken occasionally, according to its effects on the patient." Reference is made here to the Choctaw doctor who met Lincecum in the woods and taught him Choctaw herbal medicine.

*Eupatorium ageratoides* L. f., white snakeroot. "Choctaw name: *noota ikheesh* [noti, tooth; *ikhe*'sh, medicine]. Warming stimulant and tonic. The Choctaw and Chickasaw Indians use it, by chewing and holding the roots in the mouth, for toothache."

*Echinacea purpurea* (L.) Moench, purple cone-flower. "The tincture of the roots of this plant has been used with success in bad cough, and dyspepsia attended with a bad cough. . . The Choctaws use it for the above purposes, by chewing and swallowing the saliva. They keep a small piece of the root in the mouth nearly all the time, continuing its use for a long time."

One notable fact emerges when Lincecum's early nineteenth century list of Choctaw medicinal plants is compared with lists of the twentieth century. Only one plant, *Cephalanthus occidentalis*, is found in the later lists (Bushnell, 1909, p. 24), and it is reported as used for sore eyes and toothache, not for dysentery, as indicated by Lincecum. The recent lists of plants and their uses do not show a very large number of correspondences, which is probably best explained by incompleteness of data and by individual and local group variation. But the correspondences between nineteenth-century lists and recent lists are practically nonexistent. It thus appears that Choctaw herbal medicine changed considerably during the hundred-year period and that the plants in use in more recent times are not especially representative of those used in aboriginal times. This conclusion is also supported by the plaintive remark of the Sixtowns Choctaw doctor in the early 1830's about the lack of interest in medicinal plants among his own people.

Lincecum mentions no plants that were used as emetics, an absence that agrees with all later lists. The Choctaw are said to have induced vomiting by inserting a finger or a

feather in the throat (Swanton, 1931, p. 233; Taylor, 1940, p. 70). Taylor (1940, p. 70) has called attention to the absence among the Choctaw of any plants effectively used as antiperiodics and counterirritants. Lincecum's data do not conflict with this observation.

Some uses of these plants by the Choctaw are either unique or of rare occurrence in the Southeastern area. According to Lincecum, the Choctaw used the sap of *Vitis aestivalis* to induce lactation, which is the first report from the Southeast of a plant used as a lactagogue. The same is true regarding *Polygonum aviculare*, a decoction of which Choctaw women used to prevent miscarriage. The Choctaw used *Galium boreale* as a contraceptive, a usage that thus far has been reported only among the Cherokee, who used *Cicuta maculata* for this purpose (Mooney and Olbrechts, 1932, pp. 117-118; Olbrechts, 1931, p. 19). Olbrechts (ibid.) has stated his belief that the use of *Cicuta maculata* as a contraceptive among the Cherokee was probably derived from European settlers. He cites the resemblance of *Cicuta maculata* to parsley, especially in the early growth phase, and points out that parsley is still popular as an abortive in several European countries. The use of *Galium boreale* by the Choctaw suggests that herbal contraceptives may have been aboriginal in the Southeast.

#### CHICKASAW

At present very little is known about Chickasaw medicinal plants. Adair (1775, pp. 122, 164-167), writing in the latter part of the eighteenth century, refers to only two medicinal plants that can be attributed safely to the Chickasaw Indians. Swanton (1928a, pp. 266-268) has published a list of 25 medicinal plants he obtained from a Chickasaw doctor in Oklahoma sometime between the years 1915 and 1924. Most of these plants are identified by Chickasaw names, and sixteen are also identified by common English names. Taylor (1940, *passim*) has assigned scientific names to eight of the latter. To Swanton's list may be added the following six plants reported by Lincecum:

*Botrychium virginianum* (L.) Sw., Virginia grape-fern. "Chickasaw name: *hoeta hocksish*,

puke weed [Choctaw: *hoeta*, vomit; *hakshish*, root]. Emetic, diaphoretic, expectorant. I saw a Chickasaw Indian using the decoction of the root of this plant for an emetic; it operated finely. After the operation was over, he took some Tomfulla water [liquid from a pot of hominy] and said, 'I was sick but I am now well.'

*Heuchera americana* L. See Choctaw list.

*Chaerophyllum procumbens* (L.) Crantz, spreading chervil. "Chickasaw name: *shuah hokshoop*, stinking root [Choctaw: *shua*, stinking; *hakshup*, bark, husk, etc.]. The root. Emetic, poisonous. The Chickasaw use this article as an emetic, and it seems to operate very kindly, carrying off the morbid very well, always giving relief to the patient very similar to the lobelia."

*Dasystema pedicularia* (L.) Benth., fern-leaved false foxglove. "Anti-scorbutic, emetic. The Chickasaw Indians use this plant for an emetic. It resembles in its action the lobelia. The Chickasaw use it with impunity."

*Eupatorium ageratoides* L. f. See Choctaw list.

*Verbesina virginica* L., Virginia crownbeard. "Deobstruant, stimulant, diuretic, antivenereal. A tea of the root of this plant, is, with the Chickasaw Indians, a very certain cure for Fluor Albus, and in almost all cases of uterine weakness. . . I found the Chickasaw Indians using this article 20 years ago. This article was written in 1846, after experimenting with it."

Lincecum's list of six Chickasaw medicinal plants does not appear to duplicate in any way the 25 plants on the Swanton list. Adair's two eighteenth century Chickasaw medicinal plants do not appear on Swanton's list either. As in the case of the Choctaw, it seems that there has also been much change in Chickasaw materia medica since the early nineteenth century. In a chart Taylor (*ibid.*, p. 74) has indicated the absence of herbal emetics among the Chickasaw. Adair (1775, pp. 122, 164-167), Speck (1907b, pp. 55, 56), and Swanton (1928a, p. 268) all refer to specific ceremonial emetics, and Lincecum gives three additional plants used for this purpose.

#### CREEK

Creek herbal medicine is much better known. In 1904-05 Speck (1907a, pp. 118-119, 124-133, 144) obtained a list of 17 medicinal plants from the Oklahoma Creek. Eleven of these are identified by scientific

name, the remainder by English or Creek names. Swanton (1928b, pp. 639-663) has published data on 79 medicinal plants obtained from Creek informants in Oklahoma during the years 1911-12. Thirty-four of these plants are identified by scientific names; the others are identified by English and Creek names. Swanton calls attention to the fact that four of these plants are mentioned in late eighteenth century sources and that one is mentioned in an early nineteenth century source, but there are no correspondences in usage. Seven plants on the Speck list also occur on Swanton's list, but in only one instance are the uses similar. Taylor (1940, *passim*) has listed 29 Creek medicinal plants, most of which are derived from Swanton. To this we can add Lincecum's meager list of three plants:

*Persea pubescens* (Pursh) Sarg., swamp bay. "The root. Diaphoretic, hydragogue, alterant. The Muscogee, and nearly all the tribes of Southern Indians, use this article [a decoction] as a diaphoretic in fevers of all descriptions. It is also extensively used by them in dropsy. . ."

*Heuchera americana* L. See Choctaw list.

*Manfreda virginica* (L.) Salisb., false aloe. "The root. Mucilaginous. The root of this plant boiled in sweet milk and taken freely, or chewed and swallowed is a certain cure for the bite of the rattlesnake. I have known it done several times. It is a Muscogee remedy."

Of these three plants only *Manfreda virginica* appears on later lists (Swanton, 1928b, p. 645). The uses of this plant are approximately the same for both early nineteenth and early twentieth centuries, although Lincecum reports its use internally for snakebite, whereas Swanton indicates an external use. Among Lincecum's Choctaw, Chickasaw, and Creek plants, this is the nearest identity of both plant and use that occurs in early and late times.

#### SUMMARY AND CONCLUSIONS

Twenty-two medicinal plants used by Choctaw, Chickasaw, and Creek Indians in the early nineteenth century have been identified on the basis of the actual plants in Lincecum's surviving medical herbarium and his recollections of their uses by these Indians. Of these, 16 were used by the Choctaw

taw, 6 by the Chickasaw, and 3 by the Creek. Although divorced from myth and ritual, this list of plants and the accompanying data on usage add to our knowledge of folk medicine among these Muskogean-speaking peoples.

Linneum's list of 22 plants contains only 6 that have hitherto been reported for any specific Southeastern Indian group. Two of these have previously been reported for the same group—*Cephalanthus occidentalis* for the Choctaw, *Manfreda virginica* for the Creek. Only for the latter are the reported uses similar. The following five plants on Linneum's list are now recorded for these Southeastern Indian groups: *Botrychium virginianum*, Chickasaw and Cherokee (Mooney and Olbrechts, 1932, p. 177); *Vitis aestivalis*, Choctaw, Creek (Swanton, 1928b, pp. 645, 660), and Cherokee (Mooney and Olbrechts, 1932, p. 660); *Eryngium aquaticum*, Choctaw, Alabama (Taylor, 1940, p. 45), Koasati (ibid.), and Cherokee (Mooney and Olbrechts, 1932, p. 245); *Cephalanthus occidentalis*, Choctaw (Bushnell, 1909, p. 24), Chickasaw (Taylor, 1940, p. 58), and Koasati (ibid.); *Verbesina virginica*, Chickasaw and Choctaw (Bushnell, 1909, p. 23). Identity of usage occurs only in the case of *Botrychium virginianum*, which both Chickasaw and Cherokee used for an emetic.

Two plants on Linneum's Choctaw list were used for purposes not previously reported among Southeastern Indians—*Vitis aestivalis* to induce lactation and *Polygonum aviculare* to prevent miscarriage. The aboriginal use of herbal contraceptives in the Southeast, reported in recent times for the Eastern Cherokee and doubted by Olbrechts, may now be reexamined in the light of Linneum's report of a similar use among the nineteenth century Choctaw.

Such evidence as we have—and the Linneum record is about all that we do have—indicates that herbal medicine among the Choctaw of Mississippi and Louisiana changed markedly after the early nineteenth century. The principal changes were in plant species and their uses rather than in methods of drug preparation. It should be noted that these Choctaw did not remove to Indian

Territory but remained in their aboriginal area. Although less evidence is available, similar and probably even more extensive changes occurred in Chickasaw and Creek medicine, for these two groups emigrated to a different natural environment. Few will doubt that much change did occur in the herbal medicine of all these people. The point is that heretofore very little concrete evidence of change has been available.

#### LITERATURE CITED

- ADAIR, JAMES. *The history of the American Indians*. London, 1775.
- BUSHNELL, DAVID I., JR. *The Choctaw of Bayou Lacomb, St. Tammany Parish, Louisiana*. Bur. Amer. Ethnol. Bull. 48. 1909.
- BYINGTON, CYRUS. *A dictionary of the Choctaw language* (edited by John R. Swanton and Henry S. Halbert). Bur. Amer. Ethnol. Bull. 46. 1915.
- CUSHMAN, H. B. *History of the Choctaw, Chickasaw, and Natchez Indians*. Greenville, Tex., 1899.
- GEISER, SAMUEL WOOD. *Naturalists of the frontier*. Dallas, 1948.
- LINNEUM, GIDEON. *Autobiography of Gideon Linneum*. Publ. Mississippi Hist. Soc. 8: 443-519. 1904a.
- . *Choctaw traditions about their settlement in Mississippi and the origin of their mounds*. Publ. Mississippi Hist. Soc. 8: 521-542. 1904b.
- MOONEY, JAMES, AND OLBRECHTS, FRANS M. *The Swimmer manuscript: Cherokee sacred formulas and medicinal prescriptions*. Bur. Amer. Ethnol. Bull. 99. 1932.
- OLBRECHTS, FRANS M. *Cherokee belief and practice with regard to childbirth*. Anthropos 26: 17-33. 1931.
- SPECK, FRANK G. *The Creek Indians of Taskigi town*. Amer. Anthrop. Assoc. Mem. 2. 1907a.
- . *Notes on Chickasaw ethnology and folklore*. Journ. Amer. Folk-lore 20: 50-58. 1907b.
- SWANTON, JOHN R. *Social and religious beliefs and usages of the Chickasaw Indians*. 44th Ann. Rep. Bur. Amer. Ethnol.: 169-273. 1928a.
- . *Religious beliefs and medical practices of the Creek Indians*. 42d Ann. Rep. Bur. Amer. Ethnol.: 473-672. 1928b.
- . *Source material for the social and ceremonial life of the Choctaw Indians*. Bur. Amer. Ethnol. Bull. 103. 1931.
- TAYLOR, LYDA AVERILL. *Plants used as curatives by certain Southeastern tribes*. Cambridge, Mass., 1940.

**PALEONTOLOGY.**—Notes on *Phanocrinus cylindricus* and description of new species of Chester crinoids. HARRELL L. STRIMPLE, Bartlesville, Okla. (Communicated by Alfred R. Loeblich, Jr.)

In this paper I present notes on the Fayetteville formation manifestation of *Phanocrinus cylindricus* and describe the following new species of Chester crinoids: *Eupachyrcrinus modernus*, *Aphelecrinus planus*, *Aphelecrinus exoticus*, and *Scytalocrinus aftonensis*.

Genus *Phanocrinus* Kirk, 1937

*Phanocrinus cylindricus* Miller and Gurley  
Fig. 11

The species was well defined by Miller and Gurley (1894) and is readily distinguished from other described species by the full deep calyx and the 10 long, slow-tapering, uniserial arms. The surface of the dorsal cup was said to be granular. Horizon was given as "Kaskaskia group," of Pulaski County, Ky.

Kirk (1937) referred the species to *Phanocrinus* and has been followed by Sutton and Hagan (1939) and Sutton and Winkler (1940). The later authors described and figured a specimen from the Walker Museum collection as a syntype from the "Chester series of Pulaski County, Kentucky." They specified that no granulations were present.

Bassler and Moodey (1943) gave a more specific horizon for the species as "Chester-Glen Dean" but did not give a more specific locality.

The author considers it a matter worth recording that specimens readily identified as *P. cylindricus* have been collected from the Fayetteville formation, Chester, of Craig County, Okla., which decidedly show not only granulations on the surface of the cup plates, but also along the lateral sides of the axillary first primibrachials and the first secundibrachials. On the dorsal cup, granules are more prevalent on the RR and plates of the posterior interradius than elsewhere. On occasions the granules tend to become confluent and form irregular shaped narrow ridges. Apparently weathering, or possibly rolling about on the bottom of the ancient ocean, or both, had a tendency to obliterate the granulations except where protected along the impressed sutures and the lateral sides of the brachials. In many instances the granulations are difficult to discern except with the aid of low-powered magnification.

Two well-preserved crowns of *P. cylindricus*

from the Fayetteville formation of northeastern Oklahoma are being deposited in the U. S. National Museum. The figured specimen was collected by Claude Bronaugh, of Afton, Okla.

Genus *Eupachyrcrinus* Meek and Worthen, 1865

*Eupachyrcrinus modernus*, n. sp.  
Figs. 6-8

Dorsal cup is bowl-shaped, with broad basal concavity. Five small IBB are almost entirely covered by the large proximal columnal, but the triangular shaped extremities are visible. Five large BB form a good portion of the cup walls and curve sharply under to form also the sides of the basal invagination. Five large RR are slightly wider than long. Three large anal plates are present in the broad, mildly protruded posterior interradius. Anal X is hexagonal, with lower edge in broad contact with the truncated upper extremity of post. B. RA is pentagonal and lies obliquely on the right shoulder of post. B and a left facet of r. post. B. The hexagonal RX is directly above RA and to the right of anal X. All cup plates are tumid and are devoid of ornamentation.

First primibrachials are wide, axillary in all rays and fill the upper faces of RR. A second bifurcation takes place with the first secundibrachials in the anterior rays of the l. post. and r. ant. rami and in the posterior ray of the r. post. ramus. Both the left anterior and anterior rays have only two arms. In proximal portions of the arms the arrangement is uniserial but quickly becomes biserial. Delicate pinnules are present.

The proximal columnal has a mildly pentagonal outline and is pierced by a small pentalobate lumen. The anal sac is partially exposed and is small, round, composed of thin hexagonal plates, probably five to a circlet.

Measurements in mm.—As follows:

	<i>Holotype</i>
Height of dorsal cup.....	6.0
Maximum width of cup.....	13.5
Length of l. post. B.....	7.7 <sup>1</sup>
Width of l. post. B.....	6.2 <sup>1</sup>
Length of interbasal suture.....	4.7 <sup>1</sup>
Length of l. ant. R.....	4.6 <sup>1</sup>
Width of l. ant. R.....	7.0 <sup>1</sup>
Length of interradial suture.....	2.7
Diameter of proximal columnal.....	3.2

<sup>1</sup> Measurements taken along normal curvature of plates.

*Remarks.*—This species is different from normal representatives of the genus as interpreted by Kirk (1937) in several respects. Typical species have a second bifurcation of the arms in the right and left anterior rays, and in the anterior radius only two arms are developed. In *E. mod-ernus* the second bifurcation is in the posterior ray and the left anterior radius is restricted to two arms. Another characteristic of normal *Eupachyrcrinus* is the unusual height of the basal concavity and a weakness of IBB plates disclosed by their normal absence. In the present species IBB are in place, albeit almost entirely covered by the proximal columnal, and the inner height of BB is 1.5 mm. lower than their outer height.

*Occurrence and horizon.*—Unnamed limestone formation below the Fayetteville formation, Chester, Mississippian; railroad cut about 3 miles southwest of Locust Grove, Okla.

*Holotype.*—Collected by the author. To be deposited in the U. S. National Museum.

Genus *Aphelecrinus* Kirk, 1944

*Aphelecrinus planus*, n. sp.

Figs. 9-11

Dorsal cup is low cone-shaped. The holotype is slightly distorted by lateral compression. Five IBB extend only slightly beyond the large, round columnar scar, and are upflared. Five BB are large and form a good portion of the calyx walls. They have a pentagonal outline but actually possess six sides with the exception of the posterior and right posterior which each have an extra facet for contact with plates of the anal interradius. Five RR are distinctive pieces. Outwardly directed articulating facets do not fill the width of RR and the outer faces of RR are extended along the interradial sutures to the innermost extremities of the plates. Posterior interradius is composed of three plates in normal (primitive) arrangement. All cup plates are unornamented.

There is an isotomous division of the long, slender arms in all rays on the somewhat elongate first primibrachials. Another bifurcation is known to occur in some rays at a considerable distance from the cup. Nonaxillary brachials are alternately extended as short spines so that one lateral side of each brachial is long and carries a stout pinnule, and the opposite side of the succeeding brachial is elongate and pinnular bearing.

Tegmen has not been observed.

*Measurements in mm.*—As follows:

	<i>Holotype</i>
Length of crown.....	55.5
Height of dorsal cup.....	4.3
Maximum width of cup.....	10.7 <sup>1</sup>
Diameter of columnar scar.....	2.4
Height of l. post. B.....	3.1
Width of l. post. B.....	3.2
Length of interbasal suture.....	1.7
Height of l. ant. R.....	2.7
Width of l. ant. R.....	4.2
Height of l. ant. PBr.....	4.9
Width of l. ant. PBr.....	4.0

<sup>1</sup> Distorted.

*Remarks.*—*A. planus* appears to be more closely related to *A. limatus* Kirk (1944) than other described species. The latter is a smaller species, with more exposed IBB plates, less ornate arm structure and less pronounced indentation of the interradial areas in the upper extremity of the cup.

*Occurrence and horizon.*—Approximately 5 miles southwest of Afton, Okla.; Fayetteville formation, Chester, Mississippian.

*Holotype.*—Collected by the author. To be deposited in the U. S. National Museum.

*Aphelecrinus exoticus*, n. sp.

Fig. 5

Dorsal cup is shallow, cone-shaped. Five IBB extend slightly beyond the large, round columnar scar and are upflared in attitude. Five BB are of modest size. Five RR are rather large. Articular facets are directed outwardly and fail to fill the distal faces of RR. Lateral sides of RR are curved sharply inward and recurve to form a flat narrow surface along the interradial sutures, which surface continues into the interarticular areas. Outer ligamental areas are strongly impressed, transverse ridges are prominent and intermuscular notch is pronounced. The muscle scars are shallow, lacking in definition. Three anal plates occupy the broad, protruded posterior interradius. Arrangement of these plates is normal (primitive) and RA is the most prominent. A small but well defined depression occurs at the proximal tip of each RR and extends into the interbasal areas. All cup plates are covered with narrow, irregular, elongated ridges or pustules.

Arms and tegmen have not been observed.

*Measurements in mm.*—As follows:

	<i>Holotype</i>
Height of cup.....	2.5 (distorted)
Width of dorsal cup (right post. anterior to left anterior radius).....	11.7
Height of l. post. B.....	2.5
Width of l. post. B.....	3.0
Height of l. post. R.....	2.7 <sup>1</sup>
Width of l. post. R.....	4.6
Width of articulating facet.....	3.6
Diameter of columnar scar.....	2.2

<sup>1</sup> To outer lip of ligamental furrow.



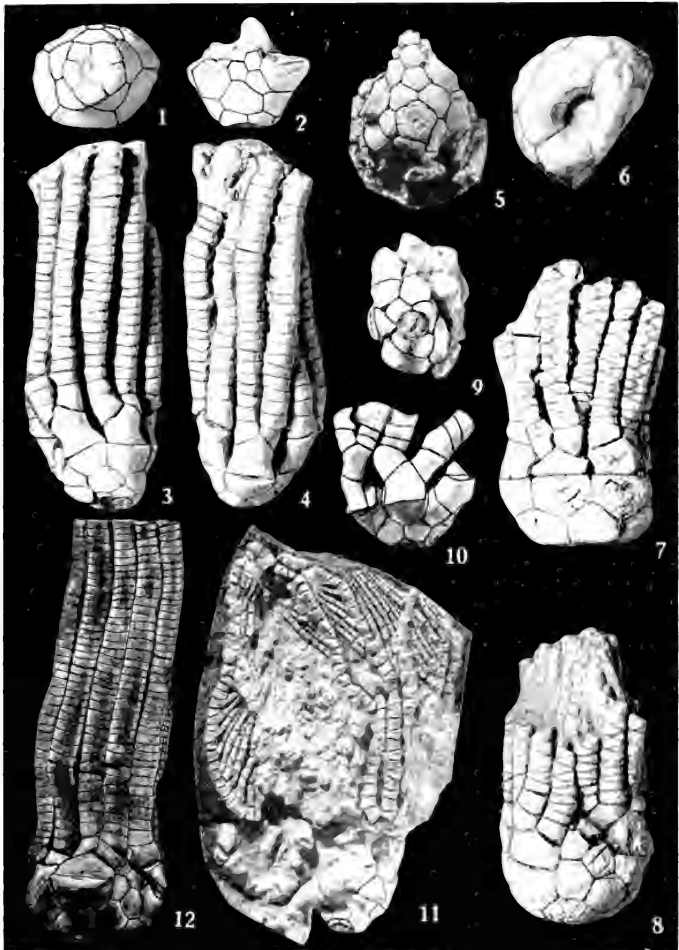

FIGS. 1-4.—*Scytalocrinus astonensis*, n. sp.: 1, 2, Paratype from basal and posterior; 3, 4, holotype from right posterior and anterior,  $\times 2$ . FIG. 5.—*Aphelecrinus exoticus*, n. sp.: Holotype from base,  $\times 1.8$ . FIGS. 6-8.—*Eupachyrcrinus modernus*, n. sp.: Holotype from base, anterior and posterior,  $\times 2$ . FIGS. 9-11.—*Aphelecrinus planus*, n. sp.: Holotype from base and anterior (Figs. 9 and 10 are enlarged  $\times 1.8$  and have been separated from the distal portions of the arms; Fig. 11 is  $\times 1.4$ , showing the entire specimen). FIG. 12.—*Phanocrinus cylindricus* (Miller and Gurley): Left posterior view of specimen from the Fayetteville formation,  $\times 1.8$ .

*Remarks.*—*A. exoticus* differs from other described species in the unusual depression of interradial sutures, dimplelike depressions at the proximal extremities of RR and in having spectacular ornamentation of cup plates.

*Occurrence and horizon.*—Approximately 5 miles southwest of Afton, Okla.; Fayetteville formation, Chester, Mississippian.

*Holotype.*—Collected by the author. To be deposited in the U. S. National Museum.

Genus *Scytalocrinus* Wachsmuth and Springer, 1880

*Scytalocrinus aftonensis*, n. sp.  
Figs. 1-4

The crown is slender, long, and compact. Dorsal cup is truncate cone-shaped. Five IBB form a subhorizontal plane about the columnar scar with distal extremities curved upward to slightly participate in lateral walls of the cup. Five BB are wide, hexagonal except for posterior and right posterior BB, which each have an extra facet for contact with anal plates. Five RR are wide, pentagonal plates with subhorizontal articulating facets filling their distal faces. Outer ligamental notches are deep and wide. Transverse ridges are well defined and the muscle scars are moderately deep. Adsutural slopes are steep. The posterior interradius is rather narrow and the three relatively small anal plates are in normal (primitive) arrangement.

There are 10 cuneiform arms branching isotomously with the first primibrachial in all rays. The surfaces of the arms are well rounded, and there is no sharp angulation between the outer areas and the lateral sides. Each secundibrachial bears a pinnule.

The columnar scar is circular in outline, slopes strongly to the lumen and is heavily crenulated. The lumen appears to be pentalobate. The entire crown is devoid of ornamentation.

*Measurements in mm.*—As follows:

	Para- type	Holo- type
Height of dorsal cup.....	6.5	4.5
Maximum width of cup.....	11.6	8.7
Height of l. post. B.....	2.8	2.5
Width of l. post. B.....	3.5	2.8
Length of interbasal suture.....	1.6	1.5
Height of l. ant. R.....	3.1	2.8
Width of l. ant. R.....	6.0	4.2
Length of interradial suture.....	2.2	2.0
Diameter of columnar scar.....	2.8	2.8

*Remarks.*—*S. aftonensis* is most readily separable from other described species in the nature of the IBB plates, which form a subhorizontal platform about the concave columnar scar, then

flex sharply upward in distal portions to participate in the lateral calyx walls.

*S. validus*, the genotype species, has IBB that do not participate in the lateral cup walls and often the anterior ramus fails to bifurcate.

*Hypselocrinus* Kirk (1940) has upflared IBB, but they rise directly from the columnar scar. In the shape of the cup, therefore, the Fayetteville species appears to occupy an intermediate position between the two genera.

The irregular length of the axillary PBrBr is comparable to that found in *Apographocrinus typicalis* Moore and Plummer as presented by the author (1938) under the name *Graphiocrinus carbonarius*. The height of these plates in mm is: l. ant. 3.8, l. post. 4.3, ant. 4.7, r. ant. 3.5, and r. post. 4.6.

*Occurrence and horizon.*—Approximately 5 miles southwest of Afton, Okla.; Fayetteville formation, Chester, Mississippian.

*Types.*—Collected by Mrs. Hazel Bronaugh, of Afton, Okla. To be deposited in the U. S. National Museum.

#### REFERENCES

- BASSLER, R. S., and MOODEY, MARGARET W. *Bibliographic and faunal index of Paleozoic Pelmatozoan Echinoderms*. Geol. Soc. Amer. Spec. Pap. 45. 1943.
- KIRK, EDWIN. *Eupachycrinus and related Carboniferous crinoid genera*. Journ. Pal. 11. 1937.
- . *Seven new genera of Carboniferous Crinoida Inadunata*. Journ. Washington Acad. Sci. 30: 321-334. 1937.
- . *Aphelecrinus, a new inadunate crinoid genus from the upper Mississippian*. Amer. Journ. Sci. 242: 190-203, pl. 1. 1944.
- MEEK, F. B., and WORTHEN, A. H. *Descriptions of new crinoids from the Carboniferous rocks of Illinois and some of the adjoining States*. Proc. Acad. Nat. Sci. Philadelphia 1865: 159.
- MILLER, S. A., and GURLEY, WM. F. E. *New genera and species of Echinodermata*. Illinois State Mus. Bull. 5: 38-39, pl. 3, figs. 19-21. 1894.
- STRIMPLE, HARRELL L. *A group of crinoids from the Pennsylvanian of northeastern Oklahoma*. 4-6, pl. 1, figs. 1-11. Priv. Publ., Bartlesville, Okla. 1938.
- SUTTON, A. H., and HAGAN, WALLACE W. *Inadunate crinoids of the Mississippian—Zeaerocrinus*. Journ. Pal. 13: 83. 1939.
- , and WINKLER, VIRGIL D. *Mississippian Inadunata—Eupachycrinus and related forms*. Journ. Pal. 14: 553-554, pl. 66, figs. 11-12. 1940.
- WACHSMUTH, C., and SPRINGER, F. *Revision of the Palaeocrinidae, pt. 1*. Proc. Acad. Nat. Sci. Philadelphia 1879: 226-378, pl. 15-17. 1880.

BOTANY.—*A new species of Poa from Peru.* JOHN R. REEDER, Yale University.  
(Communicated by Jason R. Swallen.)

In the spring of 1947 a small bundle of grasses was received from Dr. O. P. Pearson, now at the University of California. They were part of a collection of plants made by Dr. Pearson and his wife, in the region of Lake Titicaca in southern Peru. Among them were two collections of a species apparently undescribed. A description of this species is given below. Specimens are deposited in the Herbarium of Yale University, with duplicates in the United States National Herbarium and the Academy of Natural Sciences of Philadelphia. The type is at Yale.

*Poa pearsonii* sp. nov.

Perennis, dense caespitosa; innovationibus et basibus culmorum vaginis vetustioribus subcoriaceis fuscis vel fulvis dense vestitis; culmis erectis ad 50 cm altis gracilibus teretibus vel subcompressis scabris circiter 0.8 mm diametro, binodis, nodis in  $\frac{1}{3}$  inferiore culmi sitis; vaginis artis quam internodiis plerumque longioribus subcompressis scabris; ligula lanceolata acuminata, 10–15 mm longa; laminis anguste linearibus in-

volutis setaceis vel subjuncis, 0.8–1 mm diametro, eis innovationum culmis subaequalibus, eis summum culmi versus circiter 5–8 cm longis scabris sectione transversa ovalibus 7-nerviis, nervo mediano solo prominente; paniculis pyramidalibus subpatentibus, 10–12 cm longis, axi scaberula, ramis capillaribus nutantibus, inferiore 7–8 cm longo, ad  $\frac{1}{3}$  longitudinis nudis, apicem versus spiculis instructis, ramis secundariis similibus sed solo  $\frac{1}{3}$ – $\frac{1}{2}$  longitudinis nudis, omnibus 4–6-spiculatis, pedicellis brevissimis clavatis scabris; spiculis ellipticis confertifloris 5–6 mm. longis praecipue 3-floris (raro 2-floris), flore basali hermaphrodito, floribus superioribus femineis cum staminodiis minutis (raro floribus omnibus femineis), rachillae internodiis brevissimis, flore secundo a basali vix separato; glumis acutissimis membranaceis laevibus, margine hyalinis; gluma prima 4–4.5 mm longa, uninervia, gluma secunda circiter 5 mm longa, quam flore contiguo paullo brevior; lemmatibus omnino similibus ovato-lanceolatis acutis, infimo 4.5 mm longo, superioribus decrescentibus, dorso et latere scaberulis,

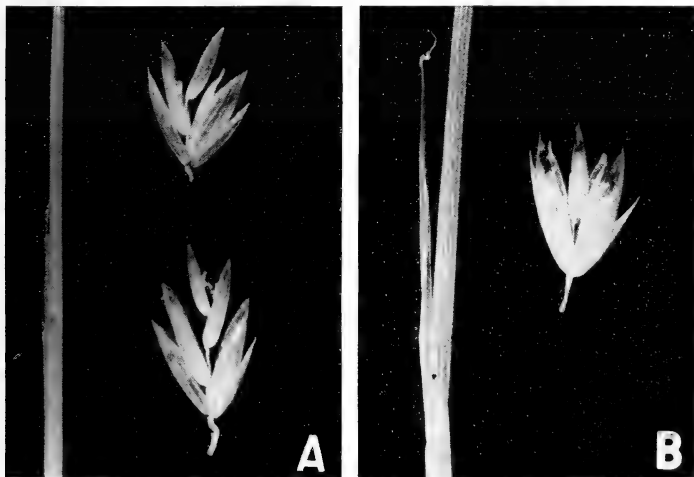

FIG. 1.—Ligules and spikelets,  $\times 5$ : A, *Poa asperiflora*; B, *Poa pearsonii*. Note that in A the ligule is short, the lemmas are prominently nerved, and the florets are separated by rather long rachilla joints. In B, the ligule is very long, the lemmas are obscurely nerved, and the rachilla joint between the first and second florets is so short that these florets appear to be borne at about the same level.

5-nerviis, nervis lateralibus obscuris quam lemmate brevioribus, callo glabro, carina basim versus puberula; palea quam lemmate paullo brevior, minute bidentata, carinis scabris; antheris in flore basali circiter 3 mm longis.

DEPARTMENT OF PUNO: Cerro Ichuasi, Coccachara, southwest of Llave, alt. about 4850 m, *O. P. & A. Pearson 91* (TYPE), November 22, 1946 (growing in gravelly soil at bottom of cliffs and alongside boulders; plants erect, in clumps, 25-50 cm tall).

The new species is apparently closely related to *Poa asperiflora* Hack., the type of which was collected in Bolivia on Titicaca Island at somewhat lower elevations. It differs from that species in having a much longer ligule, 2-noded culms and 3-flowered (rarely 2-flowered) spikelets in which the rachilla joints are very short, the second floret being scarcely raised above the basal one, the joint between the second and third floret somewhat longer. In *P. asperiflora* the ligule is about 4 mm long, the spikelets are pre-

dominantly 4-flowered (rarely 3-flowered), and the florets are separated by distinct rachilla joints, these  $\frac{1}{2}$ - $\frac{3}{4}$  the length of the florets. A further difference is seen in the florets, those of *P. pearsonii* tending to be somewhat larger and with obscurely nerved lemmas. The lemmas of *P. asperiflora* are very prominently nerved.

A second collection, *O. P. & A. Pearson 93*, from about the same location as the type but on a dry slope, appears to represent the new species. The spikelets are identical except that the florets are pistillate rather than perfect. The leaves are all distinctly shorter than the culm, and the culm seems to be 1-noded rather than 2-noded as in the type.

I wish to thank Jason R. Swallen, head curator, Department of Botany, United States National Museum, who kindly lent a type duplicate of *Poa asperiflora* Hack., and who also examined the Pearson specimens and confirmed my opinion that they represent an undescribed species.

#### ENTOMOLOGY.—*New species of Olethreutidae from Argentina (Lepidoptera).*

J. F. GATES CLARKE, U. S. Bureau of Entomology and Plant Quarantine.

The following species of olethreutid moths are described from specimens submitted by Dr. Kenneth J. Hayward, Institute Miguel Lillo, Tucumán, and Mr. Fernando Bourquin of Buenos Aires, Argentina. This is the fourth<sup>1</sup> in a series of papers dealing with Microlepidoptera from Argentina.

The photographs for this paper were taken by Robert Bonde, U. S. Department of Agriculture. Drawings by the author.

##### *Anchylopera plumbata*, n. sp.

Figs. 1, 7, 8.

Alar expanse, 11-13 mm.

Labial palpus with second segment greenish gray, with a sordid whitish transverse band exteriorly and a spot of the same color interiorly; apex of second and third segment rust color. Antenna rust color. Head, thorax, and ground color of forewing greenish gray; dorsal half of

wing from base to tornus rich dark brown, the area narrower at base and tornus than at middle, entire costa marked with short, oblique, dark-brown streaks alternating with similar metallic ones; from center of costa an accentuated dark-brown streak continuing to and confluent with a narrow triangular dark-brown area, the latter bounded by a narrow metallic line; on costa, before apex, a white lunate streak; inner contour of apex and termen fuscous edged interiorly with a narrow, broken, white line; cilia from pale grayish in tornal area to fuscous at apex with the central portion metallic. Hindwing light brown; cilia slightly lighter. Legs whitish, the fore- and midlegs strongly suffused with fuscous.

*Male genitalia*.—As figured.

*Female genitalia*.—As figured.

*Type*.—U. S. N. M. no. 61080.

*Type locality*.—Tigre, Argentina.

*Remarks*.—Described from the type male and four male and female paratypes from the type locality, all reared by Fernando Bourquin, who will publish the life history. Paratypes in the U. S. National Museum and Mr. Bourquin's collection, Buenos Aires.

The pattern of *plumbata* is similar to many other species in this genus, but there are no known close relatives.

<sup>1</sup>Notes on South American Tortricidae. Acta Zool. Lilloana 7: 579-588, 3 pls. 1949.

Two new genera and three new species of Microlepidoptera from Argentina (Gelechiidae). Journ. Washington Acad. Sci. 40: 285-289, illus. 1950.

New species of Gelechiidae from Argentina (Lepidoptera). Journ. Washington Acad. Sci. 41: 149-142, illus. 1951.

*Episimus unguiculus*, n. sp.

Figs. 2, 11, 12.

Alar expanse, 15-17 mm.

Labial palpus with second segment purplish fuscous basally, brownish distally; third segment purplish fuscous. Antenna fuscous, scape brown. Head mixed brown and purplish fuscous, gray posteriorly. Thorax brown anteriorly followed by

a gray transverse band, the latter followed by brown and purplish fuscous mixed. Forewing with purplish-fuscous ground color crossed basally with obscure brown, transverse lines; costa, from base to slightly before middle, marked with small fuscous spots; from slightly before middle of costa to apex a series of leaden-metallic, tawny-edged, oblique streaks, the second, third, and



1



2



3



4



5

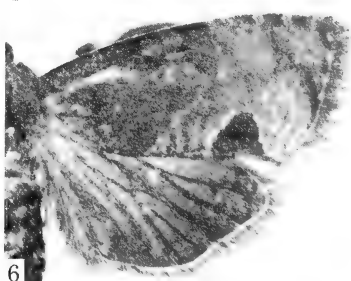

6

Figs. 1-6.—1, *Anchylopera plumbata*, n. sp., right wings; 2, *Episimus unguiculus*, n. sp., right wings; 3, *Cryptophlebia carpophagoides*, n. sp., right wings of male; 4, same, right wings of female; 5, *C. carpophaga* Walsingham, right wings of male; 6, same, right wings of female.

fourth confluent and continuing as a single streak to termen just below apex; alternating with the metallic streaks narrow triangular fuscous spots along costa; from dorsum, before middle, a fuscous line extending toward fold where it broadens

into a rectangular, tawny-edged, fuscous patch; at outer third a fuscous shade, mixed with tawny scales, extending from tornus to middle of wing where it broadens and then becomes attenuated toward costa and apex; this shade followed by a

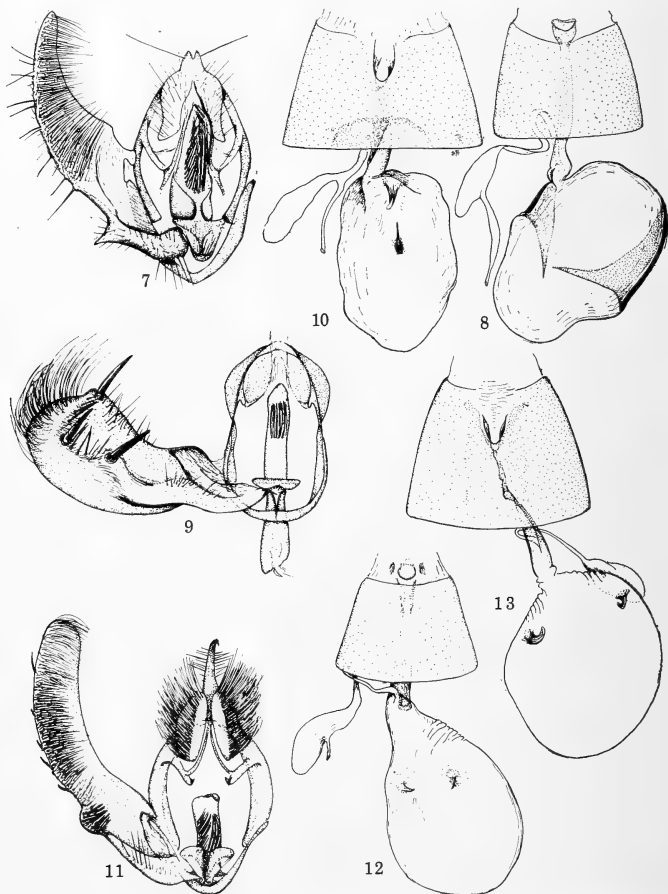

FIGS. 7-13.—7, *Anchylopera plumbata*, n. sp., ventral aspect of male genitalia with right harpe removed; 8, same, ventral view of female genitalia with ovipositor removed; 9, *Cryptophlebia carpophagoides*, n. sp., ventral view of male genitalia with right harpe removed; 10, same, ventral view of female genitalia with ovipositor removed; 11, *Episimus plumbata*, n. sp., ventral view of male genitalia with right harpe removed; 12, same, ventral view of female genitalia with ovipositor removed; 13, *Cryptophlebia carpophaga* Walsingham, ventral view of female genitalia with ovipositor removed.

transverse band of leaden-metallic scales, the latter followed by tawny; at upper angle of cell a leaden-metallic spot bounded by white; ocelloid area consisting of two short, black longitudinal dashes followed by a small transverse patch of silvery-metallic scales; the silvery-metallic patch bounded exteriorly by white scales; cilia tawny except those opposite veins 3-5, which are leaden. Hindwing fuscous; cilia light fuscous except those between vein two and apex, which are tawny with a light fuscous subbasal band. Legs ochereous-white strongly suffused and banded with fuscous.

*Male genitalia*.—As figured.

*Female genitalia*.—As figured.

*Type*.—U. S. N. M. no. 61082.

*Type locality*.—Tigre, Argentina.

*Remarks*.—Described from the type female and three male and female paratypes (the paratypes are in poor condition), from the type locality and all reared by Fernando Bourquin, who will publish the life history. Paratypes in the U. S. National Museum and Mr. Bourquin's collection, Buenos Aires.

This and the North American species *E. argutanus* (Clemens) are very closely related. The harpe of *unguiculus* is broader and more robust, and the spine cluster is nearly twice as large as that of *argutanus*. The female genitalia demonstrate extremely close affinity, the chief difference being that the ostium of *argutanus* is rectangular. The color and markings of the two are strikingly similar, but *unguiculus* differs from *argutanus* by the strong dorsal mark, the tawny terminal area, and the reduction of the white scaling before termen.

#### *Cryptophlebia carpophagoides*, n. sp.

Figs. 3, 4, 9, 10

Alar expanse 20-24 mm.

Labial palpus brownish buff to fuscous usually edged with blackish fuscous above. Antenna fuscous with slightly paler, narrow annulations. Head and thorax brownish buff to blackish fuscous; tegula warm buff to grayish buff, apex blackish fuscous. Forewing light grayish buff; in male costa suffused with fuscous with faint suggestion of alternating small fuscous and semimetallic spots; from costa at four-fifths a slightly curved fuscous line, mingled with black and semimetallic scales, extending to slightly beyond middle of termen, this line less pronounced in the female; between this line and apex two ob-

scure, short brownish lines; dorsum blackish fuscous from base to middle; on tornus a short, oblique black dash, more pronounced and larger in female than in male and edged with brown below and above in female; apical half of ground color sparsely irrorate with black. In the female the whole pale ground color obscured by brown and dark fuscous with a patch of gray-tipped scales before the tornal dash, and dull leaden patches scattered in apical half; cilia leaden. Hindwing fuscous, paler basally; cilia pale fuscous with darker subbasal line. Legs buff more or less suffused and banded with fuscous. Abdomen brownish above, buff beneath suffused with fuscous.

*Male genitalia*.—As figured.

*Female genitalia*.—As figured.

*Type*.—U. S. N. M. no. 61081.

*Type locality*.—Tucumán, Argentina.

*Food plant*.—Seeds of "pacará."

*Remarks*.—Described from the type male and six male and female paratypes from the type locality, all reared by Dr. Kenneth J. Hayward of Tucumán. Emergence dates are not indicated on the pin labels. Paratypes in the U. S. National Museum and the Instituto Miguel Lillo, Tucumán, Argentina.

This is the first record of the occurrence of the genus *Cryptophlebia* in the New World, and, although this species differs in several respects from the type of the genus, *C. carpophaga* Walsingham, there is no doubt about the relationship.

The male genitalia of both species are strikingly similar, and both bear the three large, strong setae on the harpe, as figured, but *carpophaga* lacks the smaller setae between the three large ones. In the female of *carpophagoides* there is a strongly sclerotized area on the anterior edge of the seventh sternite, but in *carpophaga* (Fig. 13) it is longitudinal and divided as illustrated. Female genitalia figured from a Guam specimen.

The male of *carpophagoides* lacks the specialized sex-scaling of the hindwing found in *carpophaga* and also lacks the ridge of long dorsal hairlike scales of the abdomen; also the tufting of the hindleg is less pronounced in *carpophagoides* than in *carpophaga*. Both species feed in the seeds of their hosts.

#### NOTE

In my article *New species of Gelechiidae from Argentina (Lepidoptera)*, Journ. Washington Acad. Sci. 41: 140, 1951, I omitted the type locality for *Parastega hemisigna* Clarke, which should have been given as "Tigre, Argentina."

ENTOMOLOGY.—*Ficalbia minima* (Theobald) in South Indochina, with descriptions of the larva and pupa (Diptera: Culicidae).<sup>1</sup> HARRY D. PRATT. (Communicated by C. W. Sabrosky.)

About 25 years ago Dr. Émile Borel began a mosquito survey of South Indochina, which culminated in the publication of his monograph "Les Moustiques de la Cochinchine et du Sud-Annam." Although Borel reported some 89 species and 16 genera of mosquitoes from South Indochina, neither he nor later French entomologists appear to have collected mosquitoes in the genus *Ficalbia* in South Indochina. Similarly neither Barraud (1934) nor any of the World War II mosquito control workers appear to have figured all stages of *Ficalbia minima* (Theobald), the type species of the genus *Ficalbia*, although Iyengar (1935) and his coworkers did collect and rear all stages of this mosquito in India. *F. minima* is reported from India, Assam, Borneo, and Hong Kong by Barraud (1934) and from Tonkin (or North Indochina) by Galliard and Ngu (1949). The finding of *minima* at Saigon now extends its southeastern distribution considerably. The present paper gives a description of the pupa, which hitherto was undescribed, together with a description of the larva and notes on the breeding habitat.

*Pupa*.—The pupa of *F. minima* is quite distinct from the other species in the genus. The pupal trumpet (Fig. 1, F) is normal, with a cleft on one side slightly more than halfway to the base. It is not modified at all for piercing the roots of aquatic plants to obtain air as in *Ficalbia chamberlaini*. Unlike most species in the genus, the first segment of the abdomen (Fig. 1, G) has a well-developed pair of dendritic tufts or "float hairs." The paddles at the tip of the abdomen have the usual spines along the latero-posterior margin. The paddles are of rather normal shape, not long and narrow as the *Ficalbia fusca* or *Ficalbia luzonensis* (cf. figures 24b, c, e, and g in Barraud, 1934).

*Larva*.—The larva of *F. minima* is very distinct on a number of characters. The preclypeal spines of the head (fig. 1, A, B) have a number of fine denticles at the base, a character found in

only a few other mosquito larvae, such as *Aedes* (*Howardina*) *walkeri* Theobald, and certain other species of mosquitoes breeding in bromeliads. The antenna (Fig. 1, A) is rather unusual in having the two long subapical hairs placed a considerable distance from the tip of the antennal shaft. In this respect the antenna is rather intermediate between the antenna of a typical *Culex* and a typical *Mansonia*. The air tube (Fig. 1, D) has the hair tuft inserted near the base rather than near the middle as in the other species of *Ficalbia*. This causes the species to run to *Theobaldia* or *Hodgesia* in the key of Barraud (1934, p. 33) even though the larva agrees in all other significant details with Barraud's figure of *minima*. There are only two pecten spines on the air tube itself (Fig. 1, D, E) and six comb scales. The comb scales (Fig. 1, C) of the Saigon specimens do not show the fine lateral denticulation of Barraud's figure (1934, fig. 27C). The Saigon specimens therefore agree better with the specimens from Tonkin reported by Galliard and Ngu (1949) in having smooth comb scales than they do with those from Hong Kong described by Barraud (1934) which have the comb scales with fine lateral denticles.

*Biology*.—On November 23 and 24, 1950, larvae and pupae of *F. minima* were found in the Botanical Garden in Saigon, Indochina, by the author and Dr. Le Du. The larvae were found in a densely shaded pool of cool, clear water containing large amounts of submerged aquatic vegetation, which appeared to be *Ceratophyllum* and floating duckweeds similar to *Lemna*. No water-lettuce (*Pistia*) was in the pool, although Iyengar (1935) and Galliard and Ngu (1949) have reported that in India and in Tonkin this species is found only in pools with that plant. They attributed this restricted habitat to the fact that *F. minima* lays its eggs on parts of the leaves of *Pistia* that overhang the water surface. The larvae were not abundant, averaging about one in every ten dips. Associated mosquito larvae were *Anopheles barbirostris*, *Culex* (*Mochthogenes*) *malayi*, and a species of *Culex* near *vishnui*. None of the larvae could be reared to the adult stage, but two of the pupae produced females that agree with the description of *F. minima* in Barraud (1934).

<sup>1</sup> From the Communicable Disease Center, Public Health Service, Federal Security Agency, Atlanta, Ga.



ACKNOWLEDGMENTS

The collections in Saigon were made while the writer was assigned as a malaria consultant with the Special Technical and Economic Mission to Vietnam of the Economic

Cooperation Administration. He wishes to acknowledge the kind assistance of Dr. H. Marneffe and M. P. Martin, of the Pasteur Institute of Saigon, for the privilege of working in their excellent library and laboratory. Dr. Alan Stone, of the U. S. Bureau of

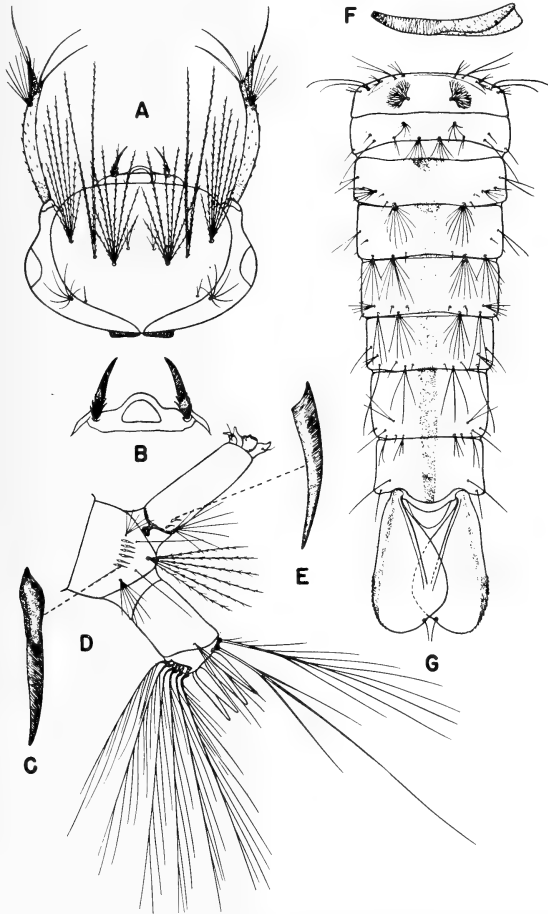

FIG. 1.—Structures of *Ficalbia minima* (Theobald): A, Head of larva, dorsal view; B, preclypeal spines of larva, dorsal view; C, comb scale of eighth abdominal segment, larva; D, terminal abdominal segments of larva; E, pecten tooth of arva; F, pupal trumpet; G, abdomen of pupa.

Entomology and Plant Quarantine, has checked the determination of the adult female and larva of *F. minima*. One adult, one pupa, and one larva have been deposited in the collections of the U. S. National Museum and the Communicable Disease Center, Atlanta, Ga. The drawings were made by C. J. Stojanovich.

#### LITERATURE CITED

BARRAUD, P. J. *The fauna of British India: Diptera* 5 (family Culicidae, tribes Megarhinini and

Culicini): xxviii + 463 pp., illus. London 1934.

BOREL, ÉMILE. 1930. *Les moustiques de la Cochinchine et du Sud-Annam*. Coll. Soc. Pathologie Exotique Monogr. III: 423 pp., illus. Paris, 1930.

GALLIARD, H., and NGU, D. V. *Culicines du Tonkin, les genre Ficalbia et Mochtogenes*. Ann. Parasit. Humaine et Compar. 24 (5/6): 495-502. 1949.

IYENGAR, M. O. T. *Biology of Indian mosquito larvae that attach themselves to the roots of water plants*. Proc. Roy. Ent. Soc. London 10 (pt. 1): 9-11. 1935.

ZOOLOGY.—*Bostrichobranchus digonas*, a new molgulid ascidian from Florida.

DONALD P. ABBOTT, Hopkins Marine Station, Stanford University. (Communicated by Fenner A. Chace, Jr.)

The common American east-coast ascidian *Bostrichobranchus pilularis* (Verrill), 1871, has a single gonad, situated on the left side of the body. Van Name (1921) reported examining a single specimen of this species, taken in St. George Sound, Fla., which was "unique in having a gonad on each side of the body." This unique specimen has been commented on (but not re-examined) by Hartmeyer (1923), Årnåbäck (1928), and Van Name (1945), all of whom have regarded it either as a reversion to an ancestral 2-gonad condition or as an individual aberration. Were it not for new evidence, presented below, the present writer would concur with the above treatment of this specimen.

Recently an opportunity arose to examine a series of specimens found stranded on the sandy beach along the Peace River estuary, Charlotte Harbor, Fla., about 20 miles from the Gulf of Mexico. According to the collector, J. C. Galloway, of Punta Gorda, Fla., the stranded ascidians formed a belt on the shore 4 to 6 inches wide and about 100 yards long, and included many thousands of individuals. Twenty-one specimens of the collection, as well as supplementary and comparative materials, were placed at my disposal for study through the kindness of Dr. Fenner A. Chace, Jr., of the Division of Marine Invertebrates, United States National Museum. Investigation of the 21 individuals from Charlotte Harbor, all of which bore two gonads, and re-examination of Van Name's unique specimen from St. George Sound show that these ascidians

represent a previously undescribed species of *Bostrichobranchus*, closely related to *B. pilularis* but unequivocally distinct from it.

#### Class ASCIDIACEA

#### Order STOLIDOBRANCHIA

Family MOLGULIDAE Forbes and Hanley, 1848

#### *Bostrichobranchus digonas*, n. sp.

*Bostrichobranchus pilularis* Van Name, 1921, p. 478 (only the specimen from St. George Sound, Fla., with a gonad on each side of body); 1945 p. 441 (only the specimen from St. George Sound, Fla., with a gonad on each side of body).

*Dimensions*.—For 12 well-expanded, turgid specimens the external dimensions of the tunic (here, as elsewhere, the mean is followed by the range in parentheses) were: Height 17 (12-20) mm; length 18 (15-20) mm; width 7 (4-10) mm.

*External appearance*.—Body oval and somewhat laterally compressed, the siphons rather short and contracted in most specimens; tunic almost completely free of sand, mud, and other debris, its surface relatively smooth and bearing scattered small tendrils, or minute papillae probably representing broken tendrils (specimens were washed ashore and probably somewhat worn externally); tunic membranous and free of wrinkles in most areas, somewhat thicker and bearing circular wrinkles on and about the bases of the siphons.

*Apertures*.—Oral aperture with six lobes, atrial aperture with four.

*Mantle*.—Thin, delicate, and transparent in most areas; muscle fibers arranged into conspicuous bundles only on the siphons, where they constitute the radial and circular muscles (Fig. 1);

radial or siphon retractor muscles consist of stout bundles running along the siphons to terminate at or slightly below their bases; a single individual out of 22 examined bore radial muscles grouped into thick bands corresponding with the lobes of the apertures; circular or siphon constrictor muscles present, these, when contracted, creating one or more distinct circular grooves around each siphon; a short series of transverse bundles overlies the dorsal intersiphonal area; occasional bundles occur elsewhere, laterally and ventrally, but these are generally so small, few in number,

widely separated, and inconspicuous as to be easily overlooked.

*Tentacles.*—Compound to branches of the third order on the largest tentacles; two-thirds of 18 individuals examined showed only three orders of tentacles, one-third possessed small fourth order tentacles as well; total number of tentacles, counting all four orders = 23 (17-34), counting only three orders = 20 (13-29); basic number of tentacles of each order apparently either 5-5-10 or 6-6-12, the alternatives appearing in about equal numbers; distribution pattern basically

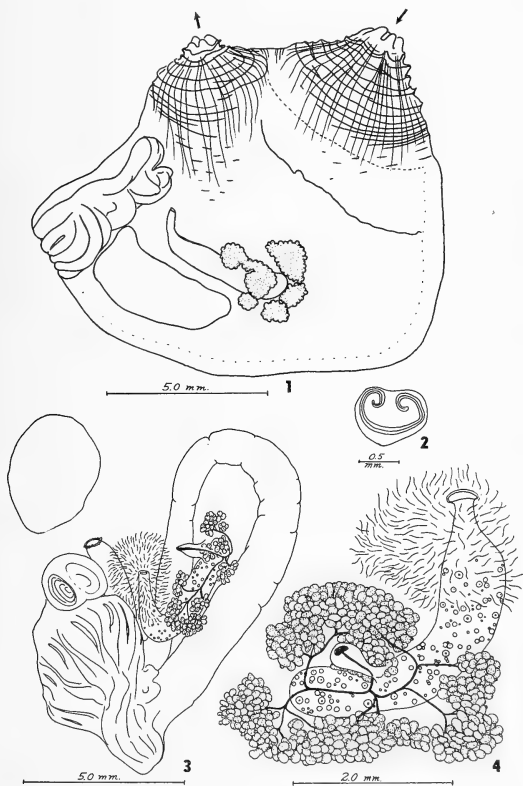

FIGS. 1-4.—*B. digonas*, n. sp.: 1, With the tunic removed, viewed from the right side; 2, dorsal tubercle; 3, medial view of digestive tract, left gonad, and atrial aperture; 4, medial view of right gonad.

-1-3-2-3-1- where three orders are present, and -1-4-3-4-2-4-3-4-1- where four orders occur; regularity of this pattern varies from perfect to rather poor, but pattern is regular in at least parts of the tentacular rings of all specimens.

*Dorsal tubercle.*—In 21 specimens examined the aperture was a U-shaped slit, with the horns sufficiently inrolled to form approximately a full circle at either end of the slit (Fig. 2); open interval directed anteriorly and usually inclined slightly toward the left.

*Dorsal lamina.*—Rather narrow anteriorly, gradually broadening posteriorly and passing some distance to the left of the esophageal opening to terminate near the "hepatic" region of the stomach; free margin smooth or slightly undulating; internal longitudinal vessels of the left side curve medially and join the base of the lamina.

*Pharynx.*—Without folds, but always with seven ribbonlike internal longitudinal vessels and five transverse vessels on each side; pharyngeal wall bearing many spirals varying from small, flat coils to very elongate, conical infundibula; each infundibulum composed of two uninterrupted, spirally intertwined stigmata separated at the apex; each stigma on the more elongate infundibula coiled six to eight turns; spirals generally about 15 (7-29) per mesh for the central fields between fifth and seventh internal longitudinal vessels (based on 85 fields counted in 17 specimens); infundibula numerous and irregularly distributed in all individuals examined, making it very difficult to distinguish primary and accessory spirals with any certainty.

*Digestive tract.*—Esophageal aperture situated about halfway posteriorly on the pharynx; esophagus short; stomach in two divisions, an upper globular portion communicating with esophagus and intestine and bearing seven or eight doubled and somewhat irregular folds as seen from its medial surface, and a lower portion, twisted posteriorly to form a small, blind "hepatic" sac ventral to the main gastric chamber; intestine forms a rather small, open primary loop, the descending limb returning to contact the proximal intestine and the rectum rising in contact with the stomach; rectum terminates near the branchio-esophageal junction in an anus whose margin bears numerous small and often irregularly distributed teeth.

*Renal organ.*—Bean-shaped, lying posteroventral to the gonad on the right side, its posterior end contacting the stomach wall.

*Gonads.*—Each of the 22 specimens examined bore a complete set of reproductive organs on each side of the body, the left gonad lying largely in the primary intestinal loop (Fig. 3); ovary on either side tubular in outline, narrowing at its posterior end into a short oviduct directed toward the atrial aperture; inner surface of mantle in the vicinity of the oviducal aperture bears a conspicuous circular path of delicate tendrils (Figs. 3, 4) probably aiding in the retention of eggs and embryos which are brooded in the atrial cavity; male glands arranged about the margin of each ovary, in a series of two to twelve clusters of lobulate testes; clusters may be clearly separated or sufficiently closely placed to form a more or less continuous border about the more anterior portions of each ovary; efferent ducts from each cluster of testes join those of adjacent clusters and run centripetally to the base of the single, large common spermatic duct which rises from near the center of the medial wall of each ovary to project freely as an erect, elongate, finger-like process into the atrium (Figs. 3, 4); in a single specimen the common spermatic duct of the left side was bifurcate; eggs present in the atria of all specimens from Charlotte Harbor (collected January 29, 1938), lying free or enmeshed in the mantle tendrils about the oviduct; eggs encased within 12- or 14-sided polyhedral membranes (whether this shape is natural or the result of preservation is uncertain); diameter of egg within polyhedral casing 0.19 (0.17-0.21) mm; atria in a few individuals contain embryos and other stages up to young prefunctional oozoids; tadpole stage absent in development.

*Specimens examined and compared* (all deposited in the U. S. National Museum), as follows:

*B. digonas*: 1 type and 20 paratypes, found stranded on the beach along the Peace River estuary, Charlotte Harbor, Fla., about 20 miles from the Gulf of Mexico, roughly at lat. 26°58' N., long. 82°02' W., U.S.N.M. nos. 10976 (holotype) and 10977-10978 (paratypes). One specimen, from St. George Sound, Fla., U.S.N.M. no. 7242 (this is the specimen with two gonads referred to by Van Name, 1921 and 1945).

*B. pitularis*: 11 specimens, from off Marthas Vineyard, 63 fathoms, U.S.N.M. no. 4940. Seven specimens, from Long Island Sound, 8 fathoms, U.S.N.M. no. 5014. One specimen, from off northwest end of St. Martins Reef, Florida banks, near lat. 28°50' N., long. 83° W., U.S.N.M. no. 7229. One specimen, from off Georgia, 10 fathoms, lat.

Feature	<i>B. digonas</i>	<i>B. pilularis</i>
Mantle musculature	Muscle bundles absent laterally and along endostyle, or if present very sparse, weak, and inconspicuous.	A row of short, stout, numerous, and conspicuous muscle bundles present on each side of body along endostyle and running at right angles to latter; a series of short muscle bundles running parallel with the circular muscles of the siphons extends downward on each side of body from atrial siphon.
Dorsal tubercle	With the horns of the slit inrolled approximately one full turn at each end.	With horns of the slit not incurved save in large individuals, and here not inrolled a full turn at each end.
Gonads	Always present on both sides of body. Anterior closed end of left ovary reaching only half to two-thirds of the way up to inner peak of primary intestinal loop. Testes usually arranged in separate clusters; these are sometimes closely apposed to form a more or less continuous series about the more anterior portions of oviduct. Inner surface of mantle surrounding oviducal aperture bearing a conspicuous circular patch of fine tendrils. Efferent ducts from clusters of testes run centripetally and unite to form a single, erect, fingerlike common spermatic duct projecting freely into atrial cavity on each side.	Present only on left side of body. Anterior closed end of left ovary reaching to, or almost to, inner peak of primary intestinal loop. Testes arranged in a continuous row about whole margin of ovary, never grouped into distinct clusters. Mantle in area adjacent to oviducal aperture smooth and unmodified. Efferent ducts from testes extend across tubular ovary to join a long common spermatic duct, which runs prostrate along whole length of ovary and lies embedded in its medial wall; along its length this common duct bears about 10 (7-15) minute papillae, each of which terminates in an aperture for the discharge of sperm.

32° N., long. 80°25' W., U.S.N.M. no. 10501.

*Specific diagnosis.*—The specific features distinguishing *B. digonas* from *B. pilularis*, the only other member of the genus, are tabulated above. In nearly all other respects, and particularly in regard to the detailed structure of the pharynx, the two species are so similar as to be nearly indistinguishable. The majority of differences concern the gonads, and the simplest method of distinguishing the species is by the presence or absence of a gonad on the right side. Both species have direct development without a tadpole larva.

*Discussion.*—*Bostrichobranchus* belongs to a small group of molgulid species sometimes called "eugyrids," which have the following characters in common: a branchial sac lacking folds, and

bearing five transverse vessels and five to seven ribbonlike internal longitudinal vessels on each side; a branchial wall bearing large spirals, often infundibulate, each of which is formed by two intertwined stigmata which are uninterrupted throughout their entire lengths but are generally separated apically; the left gonad, when present, is always placed largely or wholly in the primary intestinal loop. Attempts to subdivide this group into genera have centered around two features: the number and position of the gonads, and the presence and degree of development of secondary spirals on the pharynx.

On the basis of the number and location of the gonads alone, three eugyrid genera are sometimes recognized: *Gamaster*, with a single gonad on the right side of the body; *Eugyra*, with a single

gonad on the left side; and *Eugyroides*, with two gonads, one on each side of the body. Hartmeyer (1911), Huntsman (1922), and Årnback (1928) recognized all three genera. Huus (1937) recognized the three groups as subgenera under the genus *Eugyra*. Michaelsen (1915), Hartmeyer (1923), and Van Name (1945) united the three genera under *Eugyra*. (Van Name, 1945, actually made no mention of *Gamaster*, but by implication this group would not receive generic status in his classification.) Michaelsen (1915) and Hartmeyer (1923) were unable to find other characters to justify segregating *Eugyra* (*sensu lato*) into three genera, and concluded that differences in mere number and position of the gonads were of specific rather than generic caliber. This conclusion appears to be reinforced by the finding of the new *Bostrichobranchus* which differs from *B. pilularis* most conspicuously in its possession of a gonad on the right side.

The second character that has been used in subdividing the eugyrids into genera is the presence and degree of development of secondary spirals on the pharynx. In molgulids, stigmata arranged in spirals which lie on the pharyngeal folds or are crossed by and closely associated with the internal longitudinal vessels are called primary spirals. Any spirals which may develop on the flat areas between folds, or, where folds are absent, between the internal longitudinal vessels and their rows of associated primary spirals, are termed secondary or accessory spirals. Accessory spirals are known to occur in some species of the molgulid genera *Molgula*, *Rhizomolgula*, *Paraeugyroides*, *Bostrichobranchus*, *Eugyra* (= *Eugyra* + *Eugyroides* + *Gamaster*), and probably *Paramolgula*. In all these genera except *Bostrichobranchus* the accessory spirals, when present at all, are small, even in older individuals, though in *Rhizomolgula* they may form small conical infundibula. The single feature which clearly distinguishes *Bostrichobranchus* from other eugyrids is the relatively tremendous development and multiplication of the accessory spirals, such that in all but very young individuals it is nearly impossible to distinguish primary from secondary spirals with any certainty. This condition is not even remotely approached in any other species possessing secondary spirals. In its development, however, the pharynx of *B. pilularis* passes through a stage which closely resembles the adult condition of most *Eugyra* species (Van Name, 1912), suggesting the derivation of *Bostrichobranchus* from an ancestral *Eugyra*-like form.

Hartmeyer (1911) recognized two species of *Bostrichobranchus*, *B. manhattensis* Traustedt, 1833, and *B. molguloides* Metcalf, 1900. Van Name (1912) showed these to be conspecific with *Molgula pilularis* Verrill, 1871, but retained Traustedt's genus *Bostrichobranchus* for this species. Since this work, *Bostrichobranchus* has received recognition as a full genus by Hartmeyer (1923), Huus (1937), and (with some reluctance) Van Name (1945). Huntsman (1912) pointed out the similarities of this genus with *Eugyra* and included it in the latter with the reservation that "it might be well to retain *Bostrichobranchus* as a subgenus, if there prove to be species more closely related to *E. pilularis* than to the typical members of the genus. . ." Årnback (1928) pointed out that secondary infundibula were not unique in *B. pilularis*, and included this species in *Eugyra*. Van Name, who has studied *B. pilularis* more thoroughly than any other worker, concluded (1945) that *Bostrichobranchus* "is so close to the latter [*Eugyra*] that Huntsman's course has much to recommend it, but nevertheless the remarkable development of the accessory infundibula in the present group represents a distinct advance step in the evolution and specialization of the branchial sac which seems worthy of recognition in classification." He lists *Bostrichobranchus* as "Genus or Subgenus," giving preference to the former.

If segregation of *Bostrichobranchus* as a separate genus is suggested on the basis of one species, *B. pilularis*, such action appears to be much more strongly indicated with the discovery of the second and closely allied species *B. digonas*. Were the system of subdividing the eugyrids into genera on the basis of number and position of gonads followed here, it would be necessary to place *B. pilularis* in the genus *Eugyra* and *B. digonas* in *Eugyroides*. In view of the close structural similarity of the two species, such a generic separation would be untenable.

#### LITERATURE CITED

- ÅRNBACK-CHRISTIE-LINDE, A. *Northern and Arctic invertebrates in the collection of the Swedish State Museum: IX, Tunicata*. 3, *Molgulidae and Pyuridae*. Kungl. Svenska Vet.-Akad. Handl. 4 (9): 1-101, figs. 1-14, pls. 1-3. 1928.
- HARTMEYER, R. *Ascidien*. In Bronn, H. G., *Klassen und Ordnungen des Tierreichs* 3 (Suppl.): 1281-1773. Leipzig, 1909-1911.
- . *Ascidacea*. In Danish *Ingolf Expedition* 2 (pt. 6): 1-368, figs. 1-35, pl. 1. Copenhagen, 1923.

HUNTSMAN, A. G. *Ascidians from the coasts of Canada*. Trans. Can. Inst. **9** (1911): 111-148. 1912.  
 —. *The ascidian family Caesiridae*. Trans. Roy. Soc. Canada, ser. 3, **16**: 211-234. 1922.  
 HÜBS, J. *Ascidaceae*. In *Kükenthal und Krumbach, Handbuch der Zoologie* **5** (pt. 2): 545-692, figs. 454-581. Berlin and Leipzig, 1937.  
 METCALF, M. M. *Notes on the morphology of the Tunicata*. Zool. Jahrb., Anat., **13**: 495-602, figs. A-K, pls. 34-40. 1900.  
 MICHAELSEN, W. *Tunicata*. In *Beiträge zur Kenntnis der Meeresfauna Westafrikas* **1**: 312-518, figs. 1-4, pls. 16-19. 1915.

TRAUSTEDT, M. P. A. *Vestindiske Ascidiae Simplices. Anden Afdeling. Molgulidae og Cymthiadae*. Vid. Medd. Nat. For. Kjøbenhavn, ann. 1882: 108-136, pls. 5, 6. 1883.  
 VAN NAME, W. G. *Simple ascidians of the coasts of New England and neighboring British provinces*. Proc. Boston Soc. Nat. Hist. **34** (13): 439-619, figs. 1-43, pls. 43-73. 1912.  
 —. *Ascidians of the West Indian region and southeastern United States*. Bull. Amer. Mus. Nat. Hist. **44**: 284-494, figs. 1-159. 1921.  
 —. *The North and South American ascidians*. Bull. Amer. Mus. Nat. Hist., Vol. 84, 1-476, figs. 1-327, pls. 1-31. 1945.

PROCEEDINGS OF THE ACADEMY AND AFFILIATED SOCIETIES

ANTHROPOLOGICAL SOCIETY

The Anthropological Society of Washington at its annual meeting on January 16, 1951, elected the following officers: President, WALDO R. WEDEL; Vice President, GEORGE M. FOSTER, Jr.; Secretary, WILLIAM H. GILBERT Jr. (reelected); Treasurer, MARGARET C. BLAKER (reelected); Councilors to the Board of Managers, CORNELIUS J. CONNOLLY (reelected), MARK HANNA WATKINS (reelected), MARION L. VANDERBILT, SIDNEY ADAMS, GEORGE TRAGER, JOHN C. EWERS; Representative to the Washington Academy of Sciences, WALDO R. WEDEL.

A report of the membership and activities of the Society since the last annual meeting follows: Life members, 1; Active members, 75; Associate members, 14; Total, 90. This represents a decrease of 7 since last year.

The members elected during the year were: Active members; Dr. GORDON MACGREGOR. Associate members; Dr. DAVID F. ABERLE, ROY G. BLANCK, JOSEPH B. CASAGRANDE, Miss ANNE FORBES.

The report of the Treasurer for the year ended December 31, 1950, follows:

*Credit:*

Cash in bank	\$282.31
Income:	
Dues collected	\$95.00
Interest, Perpetual Building Association	\$60.60
Dividend, Washington Sanitary Improvement Co.	\$10.50
Dividends, Washington Sanitary Housing Co.	\$16.00
Interest, U.S. Savings Bond	\$12.50

Sales of old series <i>Anthropologists</i>	\$18.71
Total	\$213.31
	\$495.62

*Debit; Expenditures:*

AAA dues paid for Secretary, Treasurer, and one life member	\$15.00
Dues forwarded to AAA	\$10.00
Dues check returned for lack of funds	\$6.00
Speakers' expenses	\$119.00
Printing and mailing notices	\$48.07
Secretary's expenses (postage)	\$3.29
Treasurer's expenses (postage)	\$1.00
Total	\$202.36
Balance (in bank)	\$293.26

*Assets:*

Funds invested in Perpetual Building Association	\$2,000.00
2 shares Washington Sanitary Housing Co. (par value \$100 per share)	\$200.00
Sale of 42 shares @ \$32 per share, Washington Sanitary Improvement Co. (less \$3.15, expenses) authorized by Board of Managers February 14, 1950	\$1,340.85
U.S. Savings Bond, Series G	\$500.00
Cash in bank	\$1,634.11
Total as of Dec. 31, 1950	\$5,674.96
Total as of Dec. 31, 1949	\$2,272.65

All regular meetings were held at the U.S. National Museum. Programs throughout the year were arranged by Dr. EUGENE C. WORMAN, Jr. Speakers and the titles of papers presented before the regular meetings of the Society in 1950 were:

January 17, GEORGE P. MURDOCK, *A field study of the people of Truk.*

February 21, RALPH S. SOLECKI, *On the trail of Ancient Man in northern Alaska* (slides).

March 21, DUNCAN EMRICH, *Folklore, an attempt at definition.*

April 18, ROBERT M. WHITE, *Some practical applications of physical anthropology.*

May 18, FRANK M. SETZLER, *Aboriginal Australia* (in conjunction with the Washington Academy of Sciences, motion pictures).

October 19, CORNELIUS OSGOOD, *The Koreans and their culture.*

November 21, SCHUYLER CAMMANN, *Tibet, the land and its people* (slides).

December 19, GEORGE M. FOSTER, JR., *Ethnographic impressions of Spain* (slides).

A new set of bylaws for the Society was presented by the Committee consisting of Dr. WILLIAM N. FENTON, Dr. REGINA FLANNERY, and Dr. T. DALE STEWART at a meeting of Board of Managers on October 31, 1950. The suggested revisions were adopted at the annual meeting of the Society on January 16, 1951, and are as follows:

1. Membership is reduced to one class, active, in place of the former life, associate, corresponding, honorary, and active.

2. Annual dues of all members are fixed at \$1.50

a year, and provisions for subscription to the *American Anthropologist* are eliminated.

3. The officers plus six councilors and the chairman of the program committee take the place of officers plus five councilors and ex-presidents of the Society as Board of Managers.

4. The President is limited to a 2-year term and the Vice President shall serve concurrently, with the same limitation.

5. Custodial duties of the Secretary are eliminated.

6. The Treasurer is exempted from payment of dues and from submitting quarterly lists to the editor of the *American Anthropologist* of members entitled to receive this periodical.

7. Councilors to the Board of Managers shall serve three years, each year two being replaced.

8. Prescription of exact time for meetings of Board of Managers is dropped.

9. The President is to appoint a Program Committee.

10. The President is to appoint a Nominating Committee of three in advance of the annual business meeting.

11. At the annual meeting two councilors to be elected or reelected, other officers to be elected or reelected.

12. Bylaws may be amended by all members without distinction of class of membership.

A report on possibilities for reinvestment of funds resulting from the sale of 42 shares of Washington Sanitary Improvement Co. stock was submitted to the Board of Managers at the regular November meeting of the Society. At the January 16 meeting in 1951 the Treasurer was authorized to invest said funds as suggested.

WILLIAM H. GILBERT, *Secretary.*



## Officers of the Washington Academy of Sciences

*President*.....NATHAN R. SMITH, Plant Industry Station  
*President-elect*.....WALTER RAMBERG, National Bureau of Standards  
*Secretary*.....F. M. DEFANDORF, National Bureau of Standards  
*Treasurer*.....HOWARD S. RAPPLEYE, U. S. Coast and Geodetic Survey  
*Archivist*.....JOHN A. STEVENSON, Plant Industry Station  
*Custodian and Subscription Manager of Publications*  
 HARALD A. REHDER, U. S. National Museum

### *Vice-presidents Representing the Affiliated Societies:*

Philosophical Society of Washington.....EDWARD U. CONDON  
 Anthropological Society of Washington.....WALDO R. WEDEL  
 Biological Society of Washington.....  
 Chemical Society of Washington.....JOSEPH J. FAHEY  
 Entomological Society of Washington.....FREDERICK W. POOS  
 National Geographic Society.....ALEXANDER WETMORE  
 Geological Society of Washington.....LEASON H. ADAMS  
 Medical Society of the District of Columbia.....  
 Columbia Historical Society.....GILBERT GROSVENOR  
 Botanical Society of Washington.....E. H. WALKER  
 Washington Section, Society of American Foresters.....WILLIAM A. DAYTON  
 Washington Society of Engineers.....CLIFFORD A. BETTS  
 Washington Section, American Institute of Electrical Engineers  
 FRANCIS M. DEFANDORF  
 Washington Section, American Society of Mechanical Engineers..RICHARD S. DILL  
 Helminthological Society of Washington.....L. A. SPINDLER  
 Washington Branch, Society of American Bacteriologists.....ANGUS M. GRIFFIN  
 Washington Post, Society of American Military Engineers.....HENRY W. HEMPLE  
 Washington Section, Institute of Radio Engineers.....HERBERT G. DORSEY  
 District of Columbia Section, American Society of Civil Engineers  
 MARTIN A. MASON

### *Elected Members of the Board of Managers:*

To January 1952.....W. F. FOSHAG, C. L. GAZIN  
 To January 1953.....C. F. W. MUESEBECK\*, A. T. MCPHERSON  
 To January 1954.....SARA E. BRANHAM, MILTON HARRIS\*

*Board of Managers*.....All the above officers plus the Senior Editor  
*Board of Editors and Associate Editors*.....[See front cover]

*Executive Committee*.....N. R. SMITH (chairman), WALTER RAMBERG, H. S. RAPPLEYE,  
 J. A. STEVENSON, F. M. DEFANDORF

*Committee on Membership*.....L. A. SPINDLER (chairman), M. S. ANDERSON,  
 R. E. BLACKWELDER, R. C. DUNCAN, G. T. FAUST, I. B. HANSEN, D. B. JONES, DOROTHY  
 NICKERSON, F. A. SMITH, HEINZ SPECHT, ALFRED WEISSLER

*Committee on Meetings*.....MARGARET PITTMAN (chairman), NORMAN BEKKEDAHL,  
 W. R. CHAPLINE, D. J. DAVIS, F. B. SCHEETZ, H. W. WELLS

### *Committee on Monographs:*

To January 1952.....J. R. SWALLEN (chairman), PAUL H. OEHSE  
 To January 1953.....R. W. IMLAY, P. W. OMAN  
 To January 1954.....S. F. BLAKE, F. C. KRACEK

*Committee on Awards for Scientific Achievement* (GEORGE P. WALTON, general chairman):  
 For the Biological Sciences.....G. H. COONS (chairman), J. E. FABER, JR.,  
 MYRNA F. JONES, F. W. POOS, J. R. SWALLEN

For the Engineering Sciences.....R. S. DILL (chairman), ARSHAM AMIRIKIAN,  
 J. W. MCBURNEY, FRANK NEUMANN, A. H. SCOTT

For the Physical Sciences.....G. P. WALTON (chairman), F. S. BRACKETT,  
 G. E. HOLM, C. J. HUMPHREYS, J. H. McMILLEN

For Teaching of Science.....B. D. VAN EVERA (chairman), R. P. BARNES,  
 F. E. FOX, T. KOPPANYI, M. H. MARTIN, A. T. MCPHERSON

*Committee on Grants-in-aid for Research*.....L. E. YOCUM (chairman),  
 M. X. SULLIVAN, H. L. WHITTEMORE

### *Committee on Policy and Planning:*

To January 1952.....J. I. HOFFMAN (chairman), M. A. MASON  
 To January 1953.....W. A. DAYTON, N. R. SMITH  
 To January 1954.....H. B. COLLINS, JR., W. W. RUBEY

### *Committee on Encouragement of Science Talent:*

To January 1952.....M. A. MASON (chairman), A. T. MCPHERSON  
 To January 1953.....A. H. CLARK, F. L. MOHLER  
 To January 1954.....J. M. CALDWELL, W. L. SCHMITT

*Representative on Council of A. A. A. S.*.....F. M. SETZLER

*Committee of Auditors*.....J. H. MARTIN (chairman), N. F. BRAATEN, W. J. YODEN  
*Committee of Tellers*.....W. G. BROMBACHER (chairman), A. R. MERZ, LOUISE M. RUSSELL

\* Appointed by Board to fill vacancy.

## CONTENTS

	Page
MEDICINE.—Disaster and disease. VICTOR H. HAAS.....	277
ETHNOLOGY.—Medicinal plants used by Choctaw, Chickasaw, and Creek Indians in the early nineteenth century. T. N. CAMPBELL.....	285
PALEONTOLOGY.—Notes on <i>Phanocrinus cylindricus</i> and description of new species of Chester crinoids. HARRELL L. STRIMPLE.....	291
BOTANY.—A new species of <i>Poa</i> from Peru. JOHN R. REEDER.....	295
ENTOMOLOGY.—New species of Olethreutidae from Argentina. (Lepidoptera). J. F. GATES CLARKE.....	296
ENTOMOLOGY.— <i>Ficalbia minima</i> (Theobald) in South Indochina, with descriptions of the larva and pupa (Diptera: Culicidae). HARRY D. PRATT.....	300
ZOOLOGY.— <i>Bostrichobranchus digonas</i> , a new molgulid ascidian from Florida. DONALD P. ABBOTT.....	302
PROCEEDINGS: Anthropological Society.....	307

206.73  
72W23  
VOL. 41

OCTOBER 1951

No. 10

# JOURNAL

OF THE

# WASHINGTON ACADEMY OF SCIENCES

## BOARD OF EDITORS

CHARLES DRECHSLER  
PLANT INDUSTRY STATION  
BELTSVILLE, MD.

WILLIAM F. FOSHAG  
U. S. NATIONAL MUSEUM

J. P. E. MORRISON  
U. S. NATIONAL MUSEUM

## ASSOCIATE EDITORS

J. C. EWERS  
ANTHROPOLOGY

C. W. SABROSKY  
ENTOMOLOGY

F. A. CHACE, JR.  
BIOLOGY

J. I. HOFFMAN  
CHEMISTRY

T. P. THAYER  
GEOLOGY

MIRIAM L. BOMHARD  
BOTANY

R. K. COOK  
PHYSICS AND MATHEMATICS

PUBLISHED MONTHLY  
BY THE  
WASHINGTON ACADEMY OF SCIENCES  
MOUNT ROYAL & GUILFORD AVES.  
BALTIMORE, MARYLAND

Entered as second class matter under the Act of August 24, 1912, at Baltimore, Md.  
Acceptance for mailing at a special rate of postage provided for in the Act of February 28, 1925.  
Authorized February 17, 1949



## Journal of the Washington Academy of Sciences

This JOURNAL, the official organ of the Washington Academy of Sciences, publishes: (1) Short original papers, written or communicated by members of the Academy; (2) proceedings and programs of meetings of the Academy and affiliated societies; (3) notes of events connected with the scientific life of Washington. The JOURNAL is issued monthly. Volumes correspond to calendar years.

*Manuscripts* may be sent to any member of the Board of Editors. It is urgently requested that contributors consult the latest numbers of the JOURNAL and conform their manuscripts to the usage found there as regards arrangement of title, subheads, synonymies, footnotes, tables, bibliography, legends for illustrations, and other matter. Manuscripts should be typewritten, double-spaced, on good paper. Footnotes should be numbered serially in pencil and submitted on a separate sheet. The editors do not assume responsibility for the ideas expressed by the author, nor can they undertake to correct other than obvious minor errors.

*Illustrations* in excess of the equivalent (in cost) of one full-page halftone are to be paid for by the author.

*Proof.*—In order to facilitate prompt publication one proof will generally be sent to authors in or near Washington. It is urged that manuscript be submitted in final form; the editors will exercise due care in seeing that copy is followed.

*Unusual cost* of foreign, mathematical, and tabular material, as well as alterations made in the proof by the author, may be charged to the author.

*Author's Reprints.*—Reprints will be furnished in accordance with the following schedule of prices (approximate):

Copies	4 pp.	8 pp.	12 pp.	16 pp.	20 pp.	Covers
100	\$3.25	\$6.50	\$ 9.75	\$13.00	\$16.25	\$3.00
200	6.50	13.00	19.50	26.00	32.50	6.00
300	9.75	19.50	29.25	39.00	48.75	9.00
400	13.00	26.00	39.00	52.00	65.00	12.00

*Subscriptions* or requests for the purchase of back numbers or volumes of the JOURNAL or the PROCEEDINGS should be sent to HARALD A. REHDER, Custodian and Subscription Manager of Publications, U. S. National Museum, Washington 25, D. C.

*Subscription Rates* for the JOURNAL.—Per year..... \$7.50

Price of back numbers and volumes:	Per Vol.	Per Number
Vol. 1 to vol. 10, incl.—not available.*	—	—
Vol. 11 to vol. 15, incl. (21 numbers per vol.)	\$10.00	\$0.70
Vol. 16 to vol. 22, incl. (21 numbers per vol.)	8.00	0.60
Vol. 23 to current vol. (12 numbers per vol.)	7.50	0.90

\* Limited number of complete sets of the JOURNAL (vol. 1 to vol. 40, incl.) available for sale to libraries at \$341.00

MONOGRAPH No. 1, "The Parasitic Cuckoos of Africa," by Herbert Friedmann. \$4.50

PROCEEDINGS, vols. 1-13 (1899-1911) complete..... \$25.00

Single volumes, unbound..... 2.00

Single numbers..... .25

*Missing Numbers* will be replaced without charge provided that claim is made to the Treasurer within 30 days after date of following issue.

*Remittances* should be made payable to "Washington Academy of Sciences" and addressed to the Treasurer, H. S. RAPPLEYE, 6712 Fourth Street, N.W., Washington 12, D.C.

*Exchanges.*—The Academy does not exchange its publications for those of other societies.

# JOURNAL OF THE WASHINGTON ACADEMY OF SCIENCES

VOLUME 41

October 1951

No. 10

ASTRONOMY.—*The birth of stars from interstellar clouds.*<sup>1</sup> LYMAN SPITZER, JR.,  
Princeton University Observatory. (Communicated by Richard K. Cook.)

The diversity of the stars is seemingly infinite. Even a superficial study shows enormous differences in stellar sizes, brightnesses, and surface temperatures. More detailed examination reveals also differences in speeds of motion and of rotation, in constancy of brightness and shape, in the intensity of magnetization, and in chemical composition. If all this complex yet partially ordered heterogeneity resulted from differences in the process of star formation, the task of the cosmogonist would be indeed staggering.

Fortunately the problem is much simplified by an important discovery made by W. Baade. Broadly speaking, all stars can be divided into two types, named by Baade population types I and II, respectively. According to the hypothesis we shall consider here these two types of stars have had radically different origins, with those of type I formed relatively recently from interstellar clouds, and type II formed at the beginning of the universe, some 3 billion years ago. Stars of population type I we shall call "cloud stars"; these stars may be forming continuously, and we can hope to investigate in some detail the manner of their birth. Stars of population type II we shall call "primeval stars"; conditions may well have changed so much since these stars were created that a reliable and detailed theory of their formation may not yet be possible.

#### OBSERVED DIFFERENCES BETWEEN TWO TYPES OF STARS

*Velocities.*—The evidence for these two distinct types of stars may be reviewed

<sup>1</sup>The twentieth Joseph Henry Lecture of the Philosophical Society of Washington, delivered at the 1344<sup>th</sup> meeting of the Society on March 23, 1951, and presented under the title "The Formation of Stars."

briefly. As pointed out in the pioneer work by Oort, stellar velocities provided the first indication for this separation of stars into two categories. As soon as radial velocities could be determined with the spectrograph it became evident that the velocities of stars in the line of sight were distributed over a wide range. Quite unexpectedly, the physical properties of stars turned out to be correlated with their radial velocities. For example, the random radial velocities of Cepheid variable stars, whose light varies regularly with a period of some 2 to 50 days, have a root mean square radial velocity of some 10 km/sec in the galactic plane. These stars are of population type I. On the other hand, the RR Lyrae variable stars, whose period of light variation is only a day or less, but which are otherwise rather similar to Cepheid variables, show radial velocities with a root mean square value of 120 km/sec in the galactic plane. These are type II stars. This large difference in radial velocity was readily detected, especially since no elaborate techniques were required to identify a variable star in either of these two categories; simple photometric observations can determine if a star is variable and, if so, fix the nature and period of the variability.

More recent work has shown similar differences between various types of stars, and the primeval type II stars are now thought to be high-velocity stars generally, while the cloud stars of type I are moving more slowly. For example, there are many stars which are considerably less luminous than the average for their surface temperature, and which must be considerably smaller than the average dwarf star. These are called "sub-dwarfs." Their radial velocity relative to

the other stars has a root mean square value of about 150 km/sec in the galactic plane, and these may also be regarded as primeval stars. On the other hand, most stars in the neighborhood of the sun, like the sun itself, have random motions of some 10 to 20 km/sec, and these are stars of population type I, or cloud stars.

*Luminosity.*—A second major difference between the high-velocity primeval stars and the low-velocity cloud stars is the distribution of luminosity among stars of these two types. The lack of low-velocity subdwarfs has already been noted. More striking yet the brightest stars have low velocities, with no high-velocity stars more luminous than about 2,000 suns. By contrast, the super-

giant low-velocity star Betelgeuse sends out as much light and heat as about 25,000 suns, while the luminosity of certain O-type supergiants must exceed 100,000 suns. The absence of primeval supergiant stars is a striking fact.

This particular difference between cloud stars and primeval stars is presented in more detail in Fig. 1, which shows somewhat simplified Russell-Hertzsprung diagrams for these two stellar types. The bolometric luminosity, in units of the solar luminosity, is plotted on a logarithmic scale against the spectral type, which measures the surface temperature. The diagona

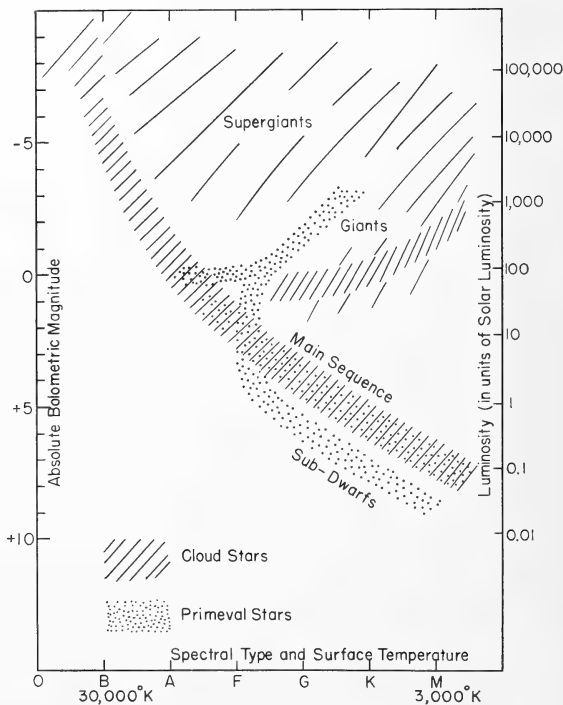

FIG. 1.—Russell-Hertzsprung diagram for both types of stars.

TABLE 1.—LIFETIME OF STARS OF DIFFERENT MASS

Mass M (in solar masses)	0.4	0.6	0.8	1.0	1.5
Mean Luminosity $\bar{L}$ (in solar luminosities).....	.044	.034	1.4	4.4	34
Lifetime (in years).....	$7 \times 10^{11}$	$1.4 \times 10^{11}$	$4.4 \times 10^{10}$	$1.8 \times 10^{10}$	$3.5 \times 10^9$

Mass M	2	4	6	8	10
Mean Luminosity $\bar{L}$ .....	140	4,400	34,000	150,000	440,000
Lifetime.....	$1.1 \times 10^9$	$7 \times 10^7$	$1.4 \times 10^7$	$4.4 \times 10^6$	$1.8 \times 10^6$

hatching indicates areas of the diagram where the cloud stars appear, while primeval stars are found primarily in the dotted regions.

Many of the differences between the Russell-Hertzsprung diagrams for these two stellar types are not yet explained. However, the lack of supergiant primeval stars has a very simple physical explanation. According to our present theory of internal constitution, a star liberates energy by the combination of four hydrogen nuclei to form helium. When all the hydrogen is gone, the star cannot go on; it may collapse to form a white dwarf or possibly explode to form a supernova. A very luminous star burns its nuclear fuel so rapidly that it cannot shine very long, and the very brightest stars cannot have been shining at their present rate for anything like three billion years.

To compute the age of these very luminous stars we may start with the mass-luminosity relation derived from the theory of stellar interiors,

$$L = AM^5\mu^2T_c^{1/2} \quad (1)$$

where  $L$ ,  $M$ , and  $T_c$  are the luminosity, mass, and central temperature of the star and  $\mu$  is the mean molecular weight. The quantity  $A$  depends on a number of physical constants and on the distribution of density within the star. This equation is valid only for stars built according to the same model as the sun; i.e., with the same relative variation of density with depth. However, it may give at least the order of magnitude for other stars. In applying this formula we shall assume that the central temperature,  $T_c$ , is the same in all stars.

To discuss the age of a star we must take into account the change of  $\mu$  with time, resulting from the conversion of hydrogen into helium. The rate of this conversion, which

liberates the energy radiated by the star, is readily determined from the observed luminosity, yielding the equation

$$\frac{d\mu}{dt} = \frac{5\mu^2 L}{4\zeta c^2 M}, \quad (2)$$

where  $\zeta$  is the fraction of mass liberated when four hydrogen atoms combine to produce a helium atom, and  $c$  is the velocity of light. The star, when formed, will be composed mostly of hydrogen, with some helium, and with  $\mu$  equal to about 0.6. When all the hydrogen is gone,  $\mu$  increases to 4/3.

From equations (1) and (2) the change of  $\mu$  and  $L$  with time may be computed. Table 1 gives the age required for exhaustion of the hydrogen for stars of different mass, together with the average luminosity  $\bar{L}$  during this period. In the computation of this table the constant  $A$  in equation (1) has been chosen to give the observed luminosity for the sun, with  $\mu$  equal to its assumed initial value, 0.6. Toward the end of a star's life, the luminosity rises far above the average, and Table 2 gives the fraction of time that a star's luminosity exceeds the average luminosity by various factors. It should be noted that the values given for large  $p$  in Table 2 are probably too great, especially for the more massive stars. Stars that have exhausted most of their hydrogen may be composite, with a helium core, a surrounding envelope of hydrogen, and a different luminosity from that obtained from equation (1). In addition, radiation pressure, which was neglected in the derivation of equation (1), will become important when  $M\mu^2$  exceeds about 10; scattering of radiation by free electrons will also be important in this range, and both these effects will tend to decrease the luminosity. For these reasons, the masses given in Table 1 for

stars of short life and high  $\bar{L}$  are somewhat too small, although the values of the lifetime for different values of the ratio  $L/M$  do not depend on equation (1) and should be accurate.

From these results let us compute the greatest possible age for a star 2,000 times as luminous as the sun, about the maximum observed for the primeval stars. If the star is just exhausting its last hydrogen, its luminosity will exceed its mean value for that star by a factor of 60.9. If the mass of the star is 1.5 times the solar mass, its mean luminosity will be about 34 suns, giving the required terminal luminosity of 2,000 suns and an age of  $3 \times 10^9$  years. Actually these particular stars are giants, with probably an inner region mostly of helium surrounded by an atmosphere of hydrogen, and more detailed computations for such configurations would doubtless change the age somewhat. However the general agreement between the age of the high-velocity type II stars and the probable age of the universe certainly suggests strongly that these stars are, in fact, primeval. By contrast, the age of a supergiant star with a spectral type O whose luminosity exceeds 100,000 suns, is less than about  $2 \times 10^6$  years even if these stars are mostly composed of helium. Such stars are unquestionably young.

*Location.*—A third major difference between cloud stars and primeval stars is in location. Primeval stars are found in almost all types of stellar systems—in globular clusters, in spherical, elliptical and spiral galaxies. Cloud stars are found only where interstellar clouds of gas and dust are present, which means primarily in the arms of spiral galaxies. In particular, the supergiant cloud stars are a characteristic feature of spiral arms, but are completely absent from other stellar systems, where gas and dust are lacking and where only primeval stars are found.

*Composition.*—A final difference between primeval stars and cloud stars is in chemical composition. These differences are not striking but seem definitely real. The atmospheres of high-velocity giants, of types G and K, show considerably weaker bands of the molecule CN than do the corresponding low-velocity giants. The CH bands, on the other hand, are strengthened; a recent analysis

TABLE 2.—INCREASE OF STELLAR LUMINOSITY WITH TIME

$p$	.25	.3	.4	.6	.8	1	1.5
Fraction of star's life in which $L$ exceeds $pL$	.87	.70	.52	.33	.24	.18	.11
$p$	2	4	6	8	10	20	40
Fraction of star's life in which $L$ exceeds $pL$	.081	.036	.021	.015	.012	.0043	.0011

The total range of  $p$  is from 0.228, when  $\mu$  equals 0.6, to 60.9, when  $\mu$  equals 1.33.

indicates that CH molecules are more abundant by a factor of about 2 in the "reversing layer" of a primeval star than in the cloud stars, while the iron atoms are less abundant by about the same ratio. These effects seem rather complicated at first sight, but it now appears that these differences may all follow from a greater preponderance of the somewhat heavier elements in the cloud stars as compared to the primeval stars.

It has been known for some years that most stars are almost entirely composed of hydrogen and helium. In fact, a chemist would regard stellar material as a mixture of "chemically pure" hydrogen and helium, since all the other elements together are present to less than one part in a thousand, by volume. The difference in composition between cloud stars and primeval stars seems to be that the former have perhaps twice as many of these impurities present as do the latter. Moreover, in the cloud stars, the ratio of iron to the carbon-nitrogen-oxygen group may be somewhat greater—perhaps by a factor of two again—than the corresponding ratio in the primeval stars.

The greater abundance of those heavier atoms in the cloud stars has two effects. Firstly, it increases the opacity in the stellar atmosphere, since it is the electrons from the easily ionized metals that do the absorbing and emitting in the atmosphere of a star whose spectral type is G, K, or M. Secondly, it increases the number of absorbing molecules per gram of matter, the increase in CN being twice as great (on a logarithmic scale) as the increase in CH. These two effects tend to offset each other, with the increase in the number of molecules winning out in the case of CN, but the increase in the continuous opacity, with a consequent decrease in the amount of matter above the



visible stellar surface, winning out in the case of CH.

It should be emphasized that these results refer to stellar atmospheres, rather than to stellar interiors. In a primeval giant star the hydrogen is mostly gone from the interior but the star is not well mixed and the atmospheric layers still retain their original composition. In fact it may be just this difference in composition between the inner and outer layers of a giant star that accounts for the large radius of such a star.

The differences outlined above between these two types of stars are summarized in Table 3. While some of the most important differences between primeval stars and cloud stars can apparently be explained, at least in a preliminary way, there are others which are less well understood. Why do planetary nebulae occur only around primeval stars? Why are the periods of variable stars so different in these two types of stars? Why do the rotational velocities of the cloud stars depend so sharply on spectral type, with low rotational speeds for stars cooler than type F5? When we know how a planetary nebula is formed, why stars pulsate, or how their rotation changes with time, perhaps we can then hope to understand these and other characteristics of cloud and primeval stars.

#### BIRTH OF PRIMEVAL STARS

Now that these two broad types of stars have been uncovered, what can we say about the origin of stars in each type? Concerning the formation of primeval stars we have relatively little information.

The problem is complicated by the fact that the density of matter in the universe may have been much greater several billion years ago than it is now. If we believe the observed velocity of recession of distant galaxies, all the galaxies were close together a few billion years ago, and what the physical conditions of matter were at that time is rather conjectural.

The chief clue is that the random velocities of these stars have now high average values. Since no mechanism has ever been suggested by which stellar velocities could increase up to a hundred kilometers per second during a few billion years, we must assume that

these stars were formed with essentially their present velocities. One may envisage a turbulent gas, more distended than our present galaxy, and perhaps at a considerably higher temperature than the 60° K characteristic of the typical interstellar gas cloud at present. Condensations in this gas might then produce high-velocity stars of various types.

As time progressed, the brightest of these stars would exhaust their hydrogen and disappear. After a life of several billion years only the less luminous stars would be still shining. If we look ahead through time, we may foresee that in the next ten billion years more and more of these primeval stars will run out of atomic fuel and disappear. Galaxies without gas and dust will grow dimmer and dimmer, and gradually go out entirely. Except for any cloud stars still being formed in spiral galaxies, the Universe will gradually grow dark.

#### BIRTH OF PROTOSTARS FROM CLOUDS

We have seen that young stars are present in and only in those regions of space where interstellar matter is also found. The circumstantial evidence for the generation of these stars from clouds seems very strong, and the formation of all low-velocity type I stars from interstellar clouds is a natural working hypothesis, which explains immediately the difference in location between high-velocity and low-velocity stars.

TABLE 3.—DIFFERENCES BETWEEN CLOUD STARS AND PRIMEVAL STARS

	Type I Cloud stars	Type II Primeval stars
Velocities	Low, 10-30 km/sec (velocities of clouds)	High, 60-180 km/sec (turbulence in primeval nebula?)
Luminosities	Range up to 10 <sup>2</sup> suns (young stars)	Brightest are 10 <sup>2</sup> suns (old stars, formed 3 × 10 <sup>9</sup> years ago)
Location	In spiral arms of galaxies with gas and dust (forming continually)	In almost all systems, including globular clusters and elliptical galaxies with no gas or dust. (Stars have no relation to present interstellar matter.)
Composition of atmosphere	10,000 H 1000 He 20 C—N—O 4 metals (concentration of grains relative to gas)	10,000 H 1000 He 10 C—N—O 1 metals (original composition of primeval matter)

Can we strengthen the net of evidence by showing in detail how a star can be formed out of "star dust"? Can we show that this theory explains the velocities and composition of these cloud stars? A detailed and rigorous demonstration of these points would be very difficult, and our present knowledge is insufficient for the task. However, the theory described here seems consistent with present evidence, and offers qualitative explanations of the various observational features already described.

Let us consider how a prestellar globule, or "protostar" might form from a gaseous medium between the existing stars. The criteria for condensation of a gas under gravitational forces were discussed by Jeans several decades ago. Jeans showed that a slight condensation would continue to contract under its own gravitational self-attraction if the initial size of the condensation exceeded a critical value  $l$ , given by the equation

$$l^2 = \frac{\pi k T}{G \rho m_0 \mu}, \quad (3)$$

where  $T$  is the gas temperature in degrees Kelvin,  $k$  the Boltzmann gas constant,  $G$  the gravitational constant,  $\rho$  the material density,  $m_0$  the mass of unit atomic weight, and  $\mu$  the mean molecular weight. This equation is derived on the assumption that the contraction is isothermal. If the diameter of a cloud is less than  $l$ , the cloud cannot hold itself together by gravitational forces.

With equation (3) in mind, we may survey briefly existing information on interstellar matter, to see whether regions exist in which gravitational contraction is possible. From measurements of the Balmer lines of hydrogen near hot stars, we know that a hydrogen gas pervades interstellar space, with a mean density of about one atom per cubic centimeter. Helium is probably also present but cannot be observed. As in the stars, the other elements are present only as slight impurities. If this deduced mean density is substituted into equation (3), the temperature is set equal to 10,000° K, and  $\mu$  is set equal to 0.5, corresponding to the nearly complete ionization of hydrogen in those regions where the Balmer lines are observed,  $l$  is found to be 2,300 parsecs (a parsec, the

standard measuring rod in astronomy, is 3.26 times the distance travelled by light in one year). This distance is some ten times greater than the thickness of the galaxy, and no initial condensation of this sort can possibly occur.

This calculation should not be taken too seriously, since it is known that the distribution of interstellar matter is far from uniform. We can not observe interstellar hydrogen in detail in most regions, but we can observe certain of the impurities in the gas. Neutral sodium and ionized calcium atoms have strong absorption lines in the accessible part of the spectrum, and absorb light from distant stars: if these stars are of early spectral type (high surface temperature), the star's own atmosphere does not produce these particular lines. Observations of these interstellar absorption lines show that the interstellar matter is distributed in separate clouds, and that these clouds have appreciable random velocities, with a root mean square value of about 10km/sec in one coordinate. In addition, many of the atoms other than hydrogen and helium stick together to form molecules of greater and greater size, which finally become tiny solid particles, or grains, about  $3 \times 10^{-5}$  cm in radius. These grains, composed mostly of the hydrogen compounds ice ( $H_2O$ ), ammonia ( $NH_3$ ) and methane ( $CH_4$ ), absorb and scatter starlight, the effect being much more pronounced for light of shorter wave lengths. Although their temperature is only 10° to 20° above absolute zero, the grains cannot retain much hydrogen, since this element will rapidly evaporate or sublime at such temperatures. Study of the absorption and scattering by these clouds confirms the irregular distribution of interstellar matter, and gives important information on the sizes of the clouds. These range from small dense nebulae less than a parsec in size to enormous clouds, or rather cloud complexes, stretching over about a hundred parsecs.

The density in these clouds is rather uncertain, as is also the "kinetic temperature" which characterizes the random motions of the atoms in the gas. Theoretical computations indicate that the random motions of the neutral hydrogen atoms in a relatively dense cloud correspond to a gas at a tempera-

ture of about  $60^\circ$  K, somewhat above the temperature of the grains, but considerably less than the  $10,000^\circ$  obtained for the predominantly ionized hydrogen near a hot star. The chief reason for this drop in temperature is that the hydrogen is completely neutral in these clouds and there is no supply of kinetic energy resulting from the absorption of ultraviolet light by hydrogen atoms and the ensuing expulsion of photoelectrons. The density in one of these clouds is probably in the neighborhood of 20 times the mean density in interstellar space, or about twenty hydrogen atoms per  $\text{cm}^3$ . Outside the clouds the densities are probably less by a factor of about 100, and the temperatures may be greater by the same factor. Thus it appears that the gas pressure may be the same in and out of clouds, and, indeed, the drop of temperature in certain regions may be the primary reason for the formation of clouds, the gas contracting as its temperature falls.

If we take these values for a typical cloud, ( $3 \times 10^{-23}$  grams  $\text{cm}^{-3}$  for  $\rho$  and  $60^\circ$  K for  $T$ ), and insert them into equation (1), we find that  $l$  is 28 parsecs. This value is greater than the diameter of the typical small cloud. The vast cloud complexes are larger than 28 parsecs across, but in these the density is less, and the rotation of the galaxy will hinder the formation of a condensation. In fact, it is readily shown that in a system rotating with the angular velocity  $\omega$  a condensation cannot contract gravitationally, regardless of its temperature, if the density is less than the limiting value  $\omega^2/2\pi G$ . In the galaxy,  $\omega$  is about  $10^{-15}$ , and the limiting density is about  $2.5 \times 10^{-24}$  gm/ $\text{cm}^3$ , or about one and a half hydrogen atoms per  $\text{cm}^3$ .

There is another condition that a cloud must fulfill if it wishes to condense. It now appears that a magnetic field is present in interstellar space. The plane polarization of light from distant stars can be explained only if a field  $B$  of about  $10^{-5}$  gauss is present to orient the grains so that their long axes are oriented in one direction or in one particular plane. With this field the magnetic energy density  $B^2/8\pi$  is about equal to the material energy density. Since the conductivity of the interstellar gas is relatively high, the magnetic lines of force are "frozen in" to the material. Any contraction of a cloud will

bring the lines of force together and increase the magnetic field strength and this requires additional energy. Thus the gravitational force must be strong enough to overcome not only the gas pressure but also the magnetic field, both of which resist contraction. It may be shown that this effect will not modify equation (3) provided that the magnetic "pressure"  $B^2/8\pi$  is small compared to the gas pressure  $n_H kT$ , where  $n_H$  is the number of hydrogen atoms per cubic centimeter in the gas. This criterion will be satisfied in a typical cloud if  $B$  is less than  $2 \times 10^{-6}$  gauss, considerably less than its average value.

Evidently a typical cloud cannot condense into stars. This is fortunate for the theory, since we know that clouds are still present, uncondensed, some three billion years since the universe was formed. Somewhat unusual conditions of low temperature, high density, and low magnetic field, such as only an occasional cloud might experience, are necessary to permit condensation to proceed. This review of the evidence gives us no reason to doubt the conclusion suggested by the observations; i.e., that new stars form continuously from interstellar clouds.

#### CONCENTRATION OF GRAINS

We have seen that the development of clouds suitable for star formation is theoretically reasonable and in accord with observations. Next we may inquire whether the composition of the cloud stars may reasonably be expected to differ from that in the primeval stars. We start with the plausible assumption that interstellar matter has the same composition as the primeval stars, an assumption which cannot as yet be checked with any precision. Then we have available an important mechanism for altering the distribution of heavy elements relative to H. This mechanism is the alteration of the ratio grains-to-hydrogen through the action of radiation pressure, a process which we shall now consider.

The existence of a pressure on any object absorbing or scattering light waves has been known for some time. This force is usually quite negligible in the laboratory, but in the space between the stars the effect becomes important, especially on tiny particles that

absorb vastly more light per gram than large objects do. The interstellar grains have a diameter about equal to the wave length of light, and for this size radiation pressure has the greatest effect. On the average the light in a galaxy is traveling in all directions. While a single grain will be knocked this way and that by the many photons it absorbs, it will not be pushed in any one direction.

This picture changes when many grains are considered. Now each little grain produces a shadow, and in this shadow there is no radiation to produce a force. If only two grains are considered, they will be pushed together by the radiation field, since in the shadow between them there is no light to push them apart. As the grains approach closer and closer, the shadow between them becomes blacker and blacker, and the force pushing them together goes up. As a result, radiation pressure produces a net attractive force between two interstellar grains which varies as the inverse square of the distance between them, exactly as the gravitational force, but which is several hundred times the gravitational force acting between the two grains. Calculations by Whipple show that if a cloud already contains a large number of grains, the radiation pressure attracting other grains outside the cloud will drive these grains through the gas and into the cloud, doubling the number of grains in the cloud within an interval of some  $10^7$  years.

An important result is apparent immediately. The grains are composed of compounds of the heavier elements with hydrogen; within a grain the ratio of hydrogen to other elements is only about 3 to 1, as compared with 1,000 to 1 in the gas. An increase in the ratio of grains to gas therefore results in a decreased ratio of hydrogen and helium to heavier elements within a cloud.

Moreover, the effect is likely to be even greater for metal atoms such as iron than for the carbon-nitrogen-oxygen group. According to the theory of Oort and van de Hulst, the grains occasionally collide with each other at high speeds, are raised to a very high temperature and evaporate. The evaporation of iron and other refractory substances will be much less rapid than that of water ( $H_2O$ ), methane ( $CH_4$ ), and ammonia

( $NH_3$ ). Thus there will be a tendency for atoms of iron and the other metals to concentrate in the grains, with relatively less metal than carbon, nitrogen, or oxygen remaining in the gas.

Only a moderate increase in the ratio of grains to gas is needed to explain the difference in composition between primeval and cloud stars. If half of the iron atoms and a fourth of the carbon, nitrogen, and oxygen atoms are locked up in the grains, then an increase by five in the ratio of grains to gas will double the ratio of carbon, nitrogen, and oxygen to hydrogen and triple the ratio of iron to hydrogen, in rough agreement with the preliminary observational evidence on the differences between cloud stars and primeval stars. Since most of the interstellar matter is in the form of hydrogen, this concentration would not change the total density appreciably. It is probably not sufficient for the grains to be entirely concentrated in the clouds of gas observed by Adams and analyzed by Strömberg; since these clouds already contain at least half the mass of the interstellar medium, a concentration of all the grains there would increase the ratio of grains to gas by at most a factor of two. We shall assume that within the various clouds the grains are pushed into the denser, cooler regions which subsequently condense into stars.

At one time I believed that the relative number of grains might become so high in this process of concentration that the value of  $l$  for gravitational condensation might be decreased. In view of recent evidence on the relatively slight difference in composition between primeval and cloud stars, this view is no longer tenable, and we must assume that the relative concentration of grains never becomes very large. Probably turbulent motions within a cloud prevent the grains from concentrating entirely in the densest region of the cloud under the influence of radiation pressure.

#### FROM PROTOSTAR TO STAR

It might be supposed that once the theorist has produced a prestellar globule, with a sufficient gravitational field to hold itself together, his task is over, and that the subsequent contraction of this protostar will

follow as a matter of course. While this supposition can perhaps be defended, in view of the strong circumstantial evidence for star formation, a detailed study shows that the possibility of this last stage is in fact very difficult to establish. In particular there is one major obstacle that the protostar must somehow circumvent if it is to contract into a star. This obstacle arises from the rotational momentum of the protostar.

The conservation of angular momentum will make the rotational velocity inversely proportional to the radius of the condensation. If the radius decreases from about a parsec down to a few solar radii, this decrease amounts to a factor of about  $10^7$ . Unless the original rotational velocity were no greater than a centimeter per second, a remarkably low value for a cloud moving through space at several kilometers a second, the contracting protostar would spin so fast that it could never contract all the way into a star.

Von Weizsäcker has suggested that turbulent motions may carry most of the angular momentum out to infinity, leaving much of the mass behind. The present author has suggested that rotation of a protostar in a weak magnetic field (about  $10^{-12}$  gauss) would generate eddy currents that would slow down the rotation, transferring the angular momentum to other regions of the Galaxy. It is possible that either of these processes, or some combination of both of them, may provide the solution to the angular momentum problem.

Magnetic fields, if unimportant initially will not impede the condensation at any subsequent stage. Since the magnetic lines of force are frozen into the material, the magnetic flux  $\pi r^2 B$  through the protostar will remain constant throughout the contraction, where  $r$  is the radius of the condensation, and  $B$  is the average field in the condensation. Hence  $B$  will vary as  $1/r^2$ , the magnetic energy density, as  $1/r^4$ , and the total magnetic energy, as  $1/r$ . The negative gravitational energy also varies as  $1/r$ . Thus if the gravitational energy much exceeds the magnetic energy at the beginning, a necessary condition for the gravitational contraction of the protostar to begin, the magnetic energy will be unimportant at all stages in the contraction.

If the conductivity of the protostar remained high throughout the contraction,  $B$  would increase by a factor of about  $10^{14}$  giving a field strength in the neighborhood of  $10^8$  gauss for the resultant star. However, it seems likely that at some intermediate stage in the contraction the conductivity will decrease sharply. Ionization produced by ultraviolet radiation will fall off markedly as the protostar becomes opaque, and until the kinetic temperature rises above  $1,000^\circ$  K there will be negligible thermal ionization. Cosmic rays will produce some free electrons, but it is still uncertain whether cosmic rays have an appreciable abundance in interstellar space, and they might fail to penetrate the strong magnetic field of the protostars. In view of these uncertainties no definite calculations seem appropriate, but the occurrence of smaller magnetic fields in stars need occasion no surprise.

There is one last evolutionary stage to be considered. After the protostar has condensed to the stellar state, with its internal temperature increasing under continual compression until atomic energy begins to be released, the process of evolution slows down. The gradual conversion of hydrogen into helium we have already discussed. This is a relatively slow process, except for the very brightest stars. Another gradual change, whose importance has recently been pointed out by Schwarzschild, is the increase of the star's velocity produced by encounters with interstellar clouds. It appears that this effect may explain the systematic observed increase of velocity with age among the cloud stars.

As pointed out by Jeans and Chandrasekhar, encounters between separate stars have a negligible effect on stellar velocities within  $10^9$  years. It does not seem to have been generally realized that the individual clouds, with a typical mass much greater than a stellar mass, have a much greater effect, even though the total amount of matter in the clouds is about the same as in the stars. Essentially, the effect of a few encounters with clouds of large mass is much greater than the effect of many encounters with less massive stars.

While the detailed analysis of this effect is complicated, the essential results may be summarized briefly. Let a group of stars

formed at a certain time have a root mean square radial velocity  $v_c$  in the galactic plane. This velocity may be identified with the root mean square radial velocity of the denser interstellar clouds, about 10 km/sec. The few clouds of very high velocity are generally less dense than the slower clouds and are presumably much less likely to condense into stars. If equipartition existed, the stars and clouds would have the same kinetic energy, and the stars, with much smaller masses, would be moving more rapidly. Collisions will attempt to approach this equipartition, and while they cannot go very far in this direction in the time available, they will increase  $v$ , the root-mean-square cloud velocity at any time. If we make the simplifying assumption that the velocities of clouds and stars are both Maxwellian, then the change of  $v$  with time is given by

$$\frac{dv}{dt} = (6\pi)^{1/2} (\log \beta) n_c m_c^2 G^2 \frac{v_c^2}{v(v^2 + v_c^2)^{3/2}} \quad (4)$$

where  $n_c$  is the number of clouds per  $\text{cm}^3$ ,  $m_c$  the mass per cloud,  $v_c$  the root-mean-square cloud velocity (in three dimensions),  $G$  the gravitational constant, and  $\log \beta$  is a somewhat uncertain parameter which we may set equal to 3.

On the basis of this equation the small interstellar clouds, whose mass is perhaps a hundred suns, do not have an important effect. However, large cloud complexes are observed in the Milky Way, each with an individual mass possibly as great as  $10^6$  suns. If the mean distance between these cloud complexes in the galactic plane is assumed to be about 350 parsecs, then  $v$  will increase from 10 to 20 km/sec in about  $10^9$  years according to equation (4). For comparison with this result, observed root mean square radial velocities for stars of different spectral types are listed in Table 4, taken from recent

results by Vyssotsky and Nordström. The table lists the root mean square velocities in one coordinate in the galactic plane (averaged over both directions in this plane). It is evident from these data that stellar velocities do in fact increase from type B (young stars) to type F (stars of all ages) in about the manner predicted by theory. The further increase of velocity for later spectral types cannot be explained on this basis, since stars of type F and later can shine for  $3 \times 10^9$  years, and stars of all ages should be present equally in these late spectral types. It appears that the greater velocity of the cooler, less luminous stars on the main sequence results from the admixture of primeval high velocity stars, which cannot readily be eliminated from the data, and which begin to outweigh the cloud stars at these low luminosities.

Evidently the present picture is uncertain in many respects, and many details will unquestionably be changed within the next few years. However, the broad difference in origin between cloud stars and primeval stars which has been sketched here seems a useful working hypothesis. One may hope that additional research will soon indicate how far this present view of star formation may be accepted as an adequate description of reality.

TABLE 4.—ROOT MEAN SQUARE RADIAL VELOCITIES IN THE GALACTIC PLANE

Spectral type	Velocity in km/sec
Main sequence	
0-B5	9.7
B8-B9	12.0
A0-A9	14.9
F0-F9	19.9
F5-G0	22.6
G0-K6	25.3
K8-M5	31.6
Giant stars	
K0-K9	20.5
M0-M9	23.3

ENTOMOLOGY.—*New American chinch bugs (Hemiptera: Lygaeidae)*. CARL J. DRAKE, Iowa State College.

The members of the genera *Blissus* Klug, *Neoblissus* Bergroth, and *Parablissus* Barber are commonly called chinch bugs. So far as known they are entirely grass-feeding insects. Several of the species are serious pests of grasses, small grain, and corn. *Blissus leucopterus* (Say) of North America ranks very high among the most injurious insect pests of corn and small grain, particularly in the States of the Midwest where corn and small grain are extensively cultivated. Grasses in United States, West Indies, and Central America are attacked by four or five different kinds of chinch bugs. Serious outbreaks of *Blissus* occur at irregular intervals, depending largely upon weather conditions.

The present paper contains the descriptions of two new species of *Blissus*, one new *Neoblissus*, and notes on several other species. The genera *Neoblissus* and *Parablissus* are peculiar to the Americas, whereas *Blissus* is represented in most of the major land divisions of the world. So far as known the species of *Neoblissus* are myrmecophilous, feeding and breeding on grasses growing inside of chambers of the nests of the vicious ant *Solenopsis saevissima* Sm. *N. weiseri*, a new species described herein, also inhabits the nests of the same species of ant in Argentina. Both species live as guests in the nest and receive no apparent care from their host. The bugs are free to wander about in the chambers, or even to leave the nests. The nymphs are not known to occur outside of the nests.

The species of *Neoblissus* are widely distributed and fairly common in ant nests; more than 1,000 nymphs and imagoes have been collected in a single nest. Nymphs of all stages and adults are found in large numbers in the nests during the growing period, whereas adults are most abundant late in summer and in winter. The adults overwinter in large numbers in the lower chambers of the nests. The late Dr. Carlos Bruch (*loc. cit.*) of La Plata has published an interesting account of *Neoblissus* in the nests of *Solenopsis saevissima*.

Unless otherwise stated, the types of the new species are in my personal collection.

Apterous and macropterous forms of two chinch bugs, *Blissus mixus* Barber (Fig. 2) and *B. iowensis* Andre (Fig. 1) are illustrated. The latter is found on the crown of bluestem grasses, often slightly below the surface of the ground.

***Blissus hirtus* Montandon**

*Blissus hirtus* Montandon, Ann. Soc. Ent. Belg. 37: 405. 1893.

In Montandon's collection there are no examples of this chinch bug from the type locality, Hazleton, Pa., M. Dietz. However, his collection contains two specimens of this insect from "*Canada, L. Provancher*," which are as hairy as typical *hirtus*. Specialists in Hemiptera are not fully in accord regarding the status of *B. hirtus* Montandon. Some workers consider it as a longly hairy variety of *B. leucopterus* (Say), whereas others treat it on the species level. It is at least a good geographic race or subspecies and not nearly so widely disseminated as typical *B. leucopterus*. At irregular intervals *B. hirtus* is a serious pest of grasses in lawns and golf courses in the northern States from Minnesota east clear across Pennsylvania and New York, and then north deep into Canada.

***Blissus pulchellus* Montandon**

*Blissus pulchellus* Montandon, Ann. Soc. Ent. Belg. 37: 406. 1893.

The type series of *B. pulchellus* in Montandon's collection contains only two specimens, each carded on a separate rectangular card and mounted on separate pins. The first pin bears (1) carded brachypterous female, (2) locality label "Costa Rica, Buenos Aires, A. Pittier," and (3) species label "*Blissus pulchellus* Montd." in Montandon's own handwriting. The other pin bears (1) a carded long-winged female and (2) the same locality label and collector. It seems that Buenos Aires is the name of a small village in Costa Rica. The apterous female is designated here as the type and the other female as a paratype. Both specimens are in fairly good condition and deposited in the Muzeul National de Istoria Naturala "grigori antipa," Bucuresti. The following notes are based on the brachypterous type.

*Short-winged female*: Length, 2.75 mm; width, 0.88 mm. Head black, slightly pruinose, with some short, pale, decumbent hairs; width across eyes, 0.60 mm; wider across eyes than median length (48:42). Antennae moderately long, shortly pilose, yellowish brown with apical segment dark fuscous; formula—I, 12; II, 25; III, 21; IV, 35. Pronotum black with pruinose in front, nearly flat above, almost rectangular in outline with sides becoming a little narrower anteriorly and more rounded on front corners, wider at base than median length (68:43). Abbreviated hemelytra almost attaining middle of abdomen, whitish with dark fuscous patch beyond middle, rather broadly rounded at apex, the veins with some erect pale hairs; membrane short, pale. Scutulum black. Abdomen above brownish, beneath bluish black. Legs yellowish brown, clothed with short pale hairs.

In the alate paratype the hemelytra do not quite reach to the apex of the abdomen, leaving most of the connexiva exposed. Length 2.90 mm.

Specimens of *B. pulchellus* from La Ceiba, Honduras, taken on *Panicum*, by F. S. Dyer, U. S. National Museum, agree very closely with the type and have been labeled by Dr. R. I. Sailer and the writer as "*comp. with type.*" Others in

the National Museum were taken on the roots of *Panicum purpurea*, Los Sabanas, Panama, James Zetek.

*Blissus brasiliensis*, n. sp. Fig. 3

Elongate, rather densely longly pilose, moderately shaggy, blackish, with abdomen reddish brown, the head, anterior part of pronotum and abdomen beneath bluish. Head a little wider across eyes than median length (56:45), with pale hairs more or less erect; tylus fuliginous; eyes small, reddish, with a few short hairs. Antennae moderately long, rather densely shortly pilose, yellowish brown with the terminal segment (also sometimes third and apex of second) dark fuscous; formula—I, 10; II, 22; III, 30; IV, 37. Rostrum testaceous, extending between middle coxae. Venter reddish brown, bluish.

*Macropterous form*: Pronotum subquadrate, slightly narrowed anteriorly, widest across humeral angles, anterior pruinose part finely punctate; hind part black, punctate, width at base much wider than median length (95:65). Abdomen almost parallel-sided. Hemelytra not quite reaching apex of abdomen, whitish, the apical angle of corium black-fuscous. Length, 3.60 mm; width, 1.00 mm.

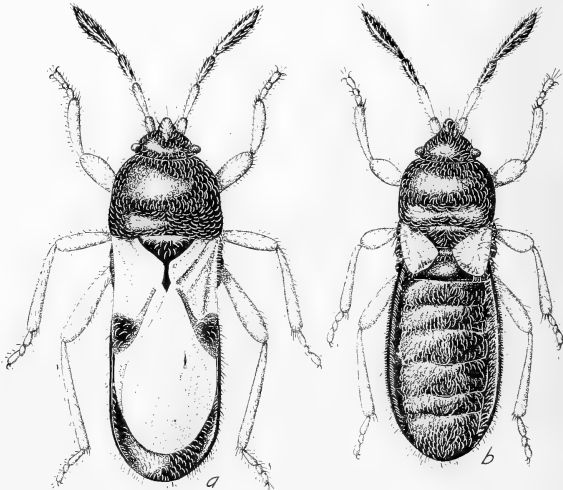

FIG. 1.—*Blissus iowensis* Andre: a, Macropterous form; b, brachypterous form.



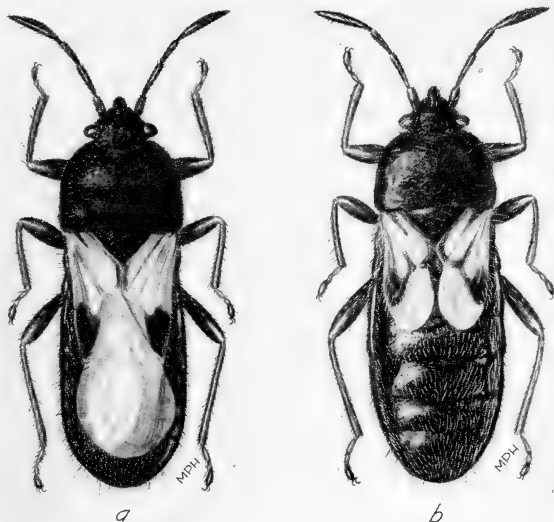

FIG. 2.—*Blissus mixus* Barber: a, Macropterous form; b, brachypterous form.

*Brachypterous form*: Abbreviated hemelytra about three-fifths as long as abdomen, whitish with dark patch a little smaller than in long-winged form. Entire insect also smaller than macropterous form. Length, 3.00 mm.

*Type*, macropterous male and *paratype* brachypterous male, Corumba, Brazil. *Allotype*, macropterous female, Santarém, Brazil.

The much shorter antennae separate this species at once from *M. penningtoni* Drake, and it is distinctly smaller with much longer pubescence or short hairs than *B. richardsoni* Drake.

*Blissus yumana*, n. sp.

Elongate, black, moderately shaggy, the abdomen reddish brown; hairs whitish, erect or partly decumbent; head, anterior half of pronotum and abdomen beneath bluish. Head wider through eyes than median length (60:60), the tylus brownish. Antennae long, longly pilose, testaceous, the fourth and sometimes the fifth segment dark fuscous; formula—I, 20; II, 40; III, 32; IV, 52. Rostrum testaceous, extending between hind coxae. Legs testaceous, clothed with short pale hairs. Pronotum much wider than

long (100:62), finely punctate, the sides with front corners more rounded; hind lobe considerably flattened.

*Macropterous form*: Hemelytra not quite attaining apex of abdomen, the dark fuscous spot in apical angle of corium extending a little into membrane; membrane with veins distinct. Length, 4.40 mm; width, 1.24 mm.

*Brachypterous form*: Hemelytra about three-fifths as long as the abdomen, with dark spot in apical angle of corium about the same size as in long-winged form; membrane short, subtransparent, narrowly rounded apically. Length, 4.20 mm.

*Type* (macropterous male), *allotype* (brachypterous female), and 6 *paratypes*, Yuma, Ariz., E. D. Ball.

The longer antennae and longer body separate this species at once from *B. leucopterus* and other North American members of the genus.

*Blissus richardsoni* Drake

*Blissus richardsoni* Drake, *Notas Mus. La Plata* 5: 224, fig. 1, 1940.

Described from a single specimen, collected

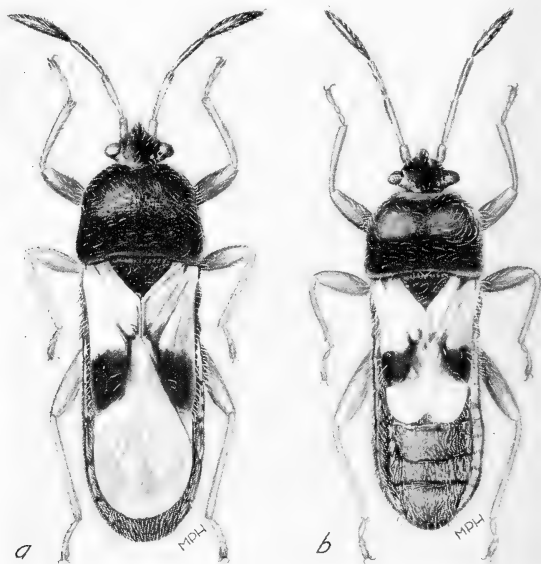

FIG. 3.—*Blissus brasiliensis*, n.sp.: a, Macropterous form; b, brachypterous form.

near Buenos Aires, Argentina. The larger and more robust size and clothing of very short hairs separate this insect at once from other Brazilian and Argentine species. The fourth antennal segment is also much longer and stouter. In addition to the type, there are two females (long- and short-winged) from Chapada, Brazil. The brachypterous form is shorter than the macropterous, and the abbreviated wings do not quite reach the middle of the abdomen. The short hemelytra are moderately long, obliquely rounded at apices, reaching almost to the apex of third visible tergite, whitish testaceous on basal half, thence dark fuscous; membrane is short, fumose; veins are moderately prominent. The pronotum is considerably flattened. Antennal formula: I, 12; II, 32; III, 26; IV, 60. The eyes bear a few short hairs.

***Neoblissus hygrobios* (Jensen-Haarup)**

*Mendocina hygrobios* Jensen-Haarup, Ent. Medd. 13: 210, fig. 1. 1920.

This chinch bug was described from a brachypterous male, taken in the Province of Mendoza, Argentina, by A. C. Jensen-Haarup, who wrongly treated it as a member of the "shore bug" family Aeophilidae and thus found it necessary to erect a new genus for its reception. A study of the description and figures shows that *hygrobios* belongs to either the genus *Blissus* or *Neoblissus* of the family Lygaeidae. At the moment it seems advisable to synonymize the genus *Mendocina* Jensen-Haarup with *Neoblissus* Bergroth.

*N. hygrobios* (Jensen-Haarup) is very similar and closely related to *N. parasigaster* Bergroth. An examination of the type of the former may prove that the two names apply to the same species. Size, shape, length of brachypterous wing pads, and color seem to be identical. There may be a little difference in the antennal formula. However, it will be necessary to examine the type of *N. hygrobios* to establish its true specific status.

The genus *Neoblissus* Bergroth was erected for the reception of a myrmecophilous chinch bug found feeding and breeding in the nests of ants (*Solenopsis saevissima*) in Brazil. The genus is very closely allied to the genus *Blissus* and is distinguished largely by the very short wing pads with wide and subtruncate apex in the brachypterous form. So far as known the species of *Neoblissus* feed and breed on grasses grown in the chambers in the nests of ants. Until more is known about myrmecophilous chinch bugs, it seems best to leave *Neoblissus* stand as a valid genus. Another species of chinch bug found inhabiting ant nests in Argentina is described below as new to science.

#### *Neoblissus parasigaster* Bergroth

*Neoblissus parasigaster* Bergroth, Entom. Zeit. Wien **23**: 253. 1903.

*Neoblissus parasigaster* Bruch, Physis **3**: 146. 1917.

*Neoblissus parasigaster* Bruch, Physis **4**: 53. 1918.

*Neoblissus parasigaster* Drake, Notas Mus. La Plata **5**: 226, fig. 3. 1940.

In the macropterous form the hemelytra are whitish, with apical angle of corium blackish fuscous, and do not reach the apex of the abdomen. The dark fuscous patch varies in size, sometimes including as much as one-half of the corium. It is widely distributed in Argentina and Brazil, where it lives as a guest in large numbers (both nymphs and adults) in the underground chambers of vicious ant nests (*Solenopsis saevissima*).

It feeds and breeds on the grasses growing on the inside of the chambers and hibernates during winter in the lower chambers. It is apparently undisturbed by the ants and is free to move in the cavities and to leave the nest. Bruch reports finding more than 1,000 chinch bugs in a single nest. The nymphs (all stages) are extremely abundant during summer, the adults during the winter months. Dr. Bruch's preliminary (*loc. cit.*) account of the relationship is very interesting, and it is unfortunate that he was never able to complete his studies.

#### *Neoblissus weiseri*, n. sp.

*Brachypterous form*: Moderately large, moderately shaggy, head and pronotum brownish black to black; abdomen reddish brown; hairy clothing moderately long fine, dense, whitish testaceous. Legs yellowish brown, clothed with short pale hairs. Antennae moderately long, shortly pilose, the terminal segment often dark; formula—I, 12; II, 25; III, 20; IV, 40. Head across eyes and median length almost subequal; tylus brownish. Rostrum testaceous, its tip reaching to base of abdomen. Orifice brownish, with large canal. Scutellum brownish to black, twice as wide as long, punctate. Hemelytral pads short, reaching on the outside to hind margin of third visible tergite; posterior margin subtruncate, very strongly oblique (or feebly rounded), within being whitish, dark in apical corner or corium, with veins brownish; veins testaceous or brownish and hairy.

Pronotum finely punctate, much wider than long (92:52), with sides becoming slightly narrower anteriorly and more rounded at anterocorners. Abdomen moderately shaggy, clothed with pale hairs, beneath being reddish brown to black, moderately hairy. Length, 3.20 mm.; width, 1.25 mm.

*Macropterous form*: Hemelytra variable in length, generally a little shorter than abdomen, sometimes considerably shorter leaving the last two tergites exposed; apex of corium with blackish spot. Length, 3.00-3.15 mm.; width, 1.25 mm.

*Type* (male) and *allotype* (female), both brachypterous, Province of Entre Ríos, Fives Lille, Santa Fé, Argentina, taken by Weiser, in La Plata Museum, Argentina. Paratypes, apterous and macropterous forms, taken with types, in the nests of the vicious and almost vicious omnivorous ants, *Solenopsis saevissima*.

Easily distinguished from *B. parasigaster* Bergroth by its smaller size and shorter antennae; and the hemelytral pads are slightly and obliquely truncate apically. The wing-pads of *B. parasigaster* are shorter and feebly obliquely truncate and very wide at apex.

ENTOMOLOGY.—*New species of chrysomelid beetles of the genera Trirhabda and Disonycha.* DORIS H. BLAKE, Arlington, Va.

The following new species of *Trirhabda* and *Disonycha* form an addition to my revisions of those genera in 1931<sup>1</sup> and 1933,<sup>2</sup> respectively. The specimens from which they were described, with one exception, had been set aside from the regular collection by H. S. Barber as new and came to light only after his death.

***Trirhabda geminata* Horn**

Figs. 2, 4, 6, 9

*Trirhabda geminata* Horn, Trans. Amer. Ent. Soc. **29**: 68. 1893.

*Trirhabda nigrohumeralis* Schaeffer, Bull. Brooklyn Inst. Arts and Sci., **1**: 170. 1905.

In my revision of the genus *Trirhabda* I stated that the "pale forms of *geminata* are sometimes difficult to distinguish from *nigrohumeralis*" but "in general *nigrohumeralis* is smaller . . . and the aedeagus quite unlike that of *geminata*, being small, tapering and rounded at the tip." At that time I did not have specimens of Schaeffer's types of *nigrohumeralis* and did not realize that the aedeagus that I was describing was from a specimen outwardly like *nigrohumeralis* but quite unlike that species in its genitalia. From labels in the collection I have found that H. S. Barber, on acquiring Schaeffer's collection and dissecting a male of that species, at once saw that what I described was really a new species. However, he does not appear to have suspected that *nigrohumeralis* itself is simply a color form of *geminata*. I am forced to this conclusion after examining specimens from many localities in California, Arizona, New Mexico, and even Texas. Horn gave as type localities "San Diego, California and Arizona." Specimens from near the coast are darker in their markings than many inland specimens, although some from Nogales and Tucson, Ariz., are fully as dark. Others from those localities are of the coloring that Schaeffer described for *nigrohumeralis* with "unicolorous pale elytra" having "an elongate narrow black humeral spot." Dissection of these specimens reveals an aedeagus like that of *geminata*. A still paler and smaller series of specimens from near Presidio, Tex., taken on *Brickellia* shows a similar

aedeagus. It appears that this species as it occurs eastward across the country grows smaller and paler in coloring. Specimens were taken by Hubbard and Schwarz at St. Rita and Nogales on *Brickellia*, and also in 1945 by an unknown collector on this food plant at Nogales. Other specimens at Nogales were taken on lettuce (collector unknown). At Cataline Springs, north-east of Tucson, they were taken by Hubbard and Schwarz on *Encelia*, and on guayule, near Tucson, by an unknown collector. The localities for *T. geminata* (including the paler forms) in the U.S. National Museum are: *California*: Claremont, Baker Coll.; *Arizona*: Bright Angel, Camp Verde, H. Brisley; Cataline Springs, Hubbard and Schwarz; Huachuca Mountains, Schaeffer Coll.; Nogales, Oracle, Hubbard and Schwarz; Palmerly, Cochise County, Schaeffer Coll.; Sta. Rita Mountains, Hubbard and Schwarz; *New Mexico*: Jemez Mountains, John Woodgate; Las Vegas, Barber and Schwarz; *Texas*: Near Presidio, collector unknown.

***Trirhabda schwarzi*, n. sp.**

Fig. 7

*Trirhabda nigrohumeralis* Blake (not Schaeffer, 1906), Proc. U. S. Nat. Mus. **79** (art. 2): 30, 31. 1931.

Between 4.5 and 7.5 mm in length, elongate oblong, pale yellow-brown, finely pubescent, the head with an oblong dark spot, mouthparts pale; three dark pronotal spots; scutellum bicolored, the elytra with a dark humeral streak, body beneath entirely pale, antennae usually pale, claw joint sometimes a little darker.

Head with a dark oblong spot down the occiput, mouthparts pale, densely and obsoletely punctate down to tubercles with a depressed median line, from tubercles down shiny and impunctate. Antennae usually pale brownish, not at all piceous. Prothorax about twice as wide as long, depressed on each side, alutaceous, with coarse punctures, pale brown with three small spots. Scutellum partly dark. Elytra pale brown with a darker humeral streak fading out down the side. Body beneath entirely pale, legs pale, except sometimes the claw joint a little darker. Length 4.6-7.4 mm; width 2-3 mm.

*Type* male and 41 paratypes, U.S.N.M. no. 61126. 2 paratypes in M.C.Z., collected at Ash-

<sup>1</sup> Proc. U. S. Nat. Mus. **79** (art. 2): 1-36. 1931.

<sup>2</sup> Proc. U. S. Nat. Mus. **82** (art. 28): 1-66. 1933.

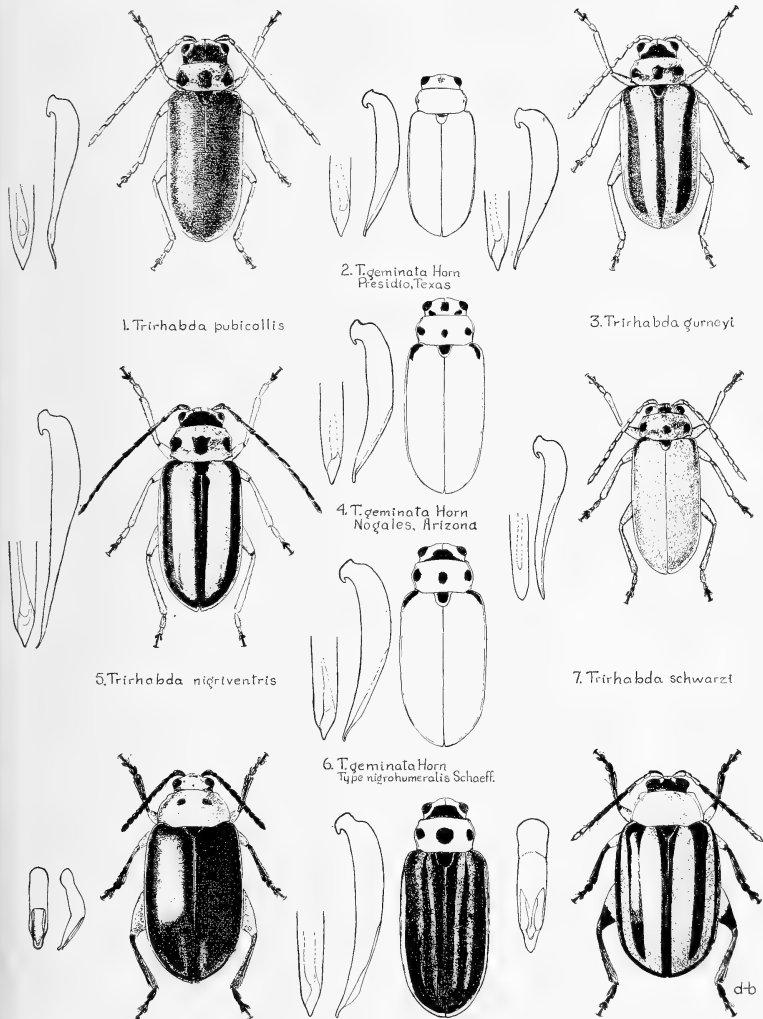

2. *T. geminata* Horn  
Presidio, Texas

1. *Trirhabda pubicollis*

3. *Trirhabda gurneyi*

4. *T. geminata* Horn  
Nogales, Arizona

5. *Trirhabda nigriventris*

7. *Trirhabda schwarzi*

6. *T. geminata* Horn  
Type *nigrohumeralis* Schaeff.

8. *Disonycha arizonae* Casey dark form

9. *T. geminata* Horn  
Nogales, Arizona

10. *Disonycha barberi*

FIGS. 1-10.—Species of *Trirhabda* and *Disonycha*

fork, Ariz., by H. S. Barber and E. A. Schwarz on June 17, 1901.

*Other locality*.—Prescott, Ariz., collected by Barber and Schwarz on June 19, 1901.

*Remarks*.—This species is outwardly well-nigh indistinguishable from the pale forms of *T. geminata* Horn (*nigrohumeralis* Schaeffer) and was the species figured and erroneously believed to be *nigrohumeralis* in my revision of the genus in 1931. The aedeagus is not at all like that of *geminata*, and there are a few minor color differences that appear to be constant—the antennae and mouthparts are pale, not piceous, and the claw joint alone is dark, whereas in *geminata*, except in palest forms, the last two tarsal joints are usually dark.

*Trirhabda pubicollis*, n. sp.

Fig. 1

About 7 mm in length, elongate oblong, densely and somewhat rugosely punctate, head, pronotum, and elytra with fine short pubescence; pale yellow-brown, the head with a deep metallic-green band extending from occiput to tubercles except for a narrow pale area about eyes; pronotum with three large irregularly shaped piceous spots, elytra metallic dark green except for a narrow yellow border, body beneath, legs and antennae pale, claw joint deeper brown.

Head densely and rather shallowly punctate over occiput and upper front with a median impressed line, finely pubescent, area above tubercles except for a narrow area about eyes entirely dark metallic green, labrum piceous edged. Antennae pale reddish brown except for a deeper brown basal joint, unusually long and slender, fourth joint about twice as long as third. Prothorax about twice as wide as long with nearly straight sides (viewed from above); depressed across the middle, especially on the sides, and coarsely punctate, surface shining, not at all alutaceous and with moderately dense pale pubescence, pale with three large, irregularly shaped piceous spots. Scutellum dark. Elytra deep metallic green with a pale yellow brown border, densely and moderately coarsely punctate and covered with fine pale pubescence. Body beneath and legs pale, the claw joints alone deeper brown. Length 7 mm; width 2.4 mm.

*Type* male U.S.N.M. no. 61127, collected at El Paso, Tex., May 2, collector unknown.

*Remarks*.—Only a single specimen is at hand,

but this one is distinctly unlike any other described from north of Mexico. It may well be a Mexican species but apparently is not described. The prothorax is unusual in being conspicuously pubescent and short. The aedeagus too is distinctive with its long tapering tip.

*Trirhabda gurneyi*, n. sp.

Fig. 3

Between 6 and 7.5 mm in length, elongate oblong, faintly shining, especially on the prothorax, with finely pubescent elytra, pale yellow-brown, the head with a wide, dark, occipital band curving down front, prothorax with the usual three dark spots, scutellum dark, elytra with piceous sutural and lateral vittae, not united at the apex, body beneath, antennae and legs pale.

Head coarsely punctate over occiput and down to frontal tubercles, with a median impressed line, pale with a dark band across occiput, curving down the front, mouthparts usually dark. Antennae as a rule pale, never deep piceous. Prothorax not quite twice as broad as long, with slightly angulate sides, depressed on either side, shining, not at all alutaceous, and more or less coarsely punctate, pale with three medium sized black spots, the middle one often shield shaped. Scutellum usually entirely dark, in 2 of the 14 specimens somewhat paler toward apex. Elytra densely and moderately coarsely punctate, the punctures not confluent, and with short fine pubescence; pale yellow brown with a narrow sutural and not very wide lateral vitta, these not uniting at apex, the sutural one becoming narrow at apex so as to darken only the sutural edges, in one specimen the lateral vitta fading out from the middle to apex. Body beneath and legs pale, the claws somewhat deeper in coloring. Length 6-7.5 mm; width 2.6-3 mm.

*Type* male and 11 paratypes, U.S.N.M. no. 61128. Two paratypes in M.C.Z., collected by A. B. Gurney at Indian Springs, Nev., June 5, 1949, on *Franseria*.

*Remarks*.—In coloring this species resembles somewhat *T. adela* Blake, except that it is always pale beneath and smaller with less densely pubescent elytra. It has also a shiny, not alutaceous prothorax. It differs from *T. nitidicollis* in not having the vittae joined at the apex and in the differently shaped prothorax.

*Trirhabda nigriventris*, n. sp.

Fig. 5

Between 6 and 9.5 mm in length, elongate oblong, finely punctate, with short, fine pubescence, head with a broad black plaga curving down over front, thorax shiny, 3-spotted, elytra with narrow sutural and lateral vittae almost always uniting at apex, frequently the lateral vitta having a paler trace of vitta as an offshoot near the apex, breast and abdomen dark.

Head with a median impressed line, densely and not very coarsely punctate over front, a broad dark occipital band curving down front, mouthparts with dark edging. Antennae long and slender, the basal joints with pale edging, distal joints entirely dark. Prothorax not quite twice as broad as long with slightly arcuate sides, depressed across, especially on the sides, shiny, more or less coarsely punctate, with three black spots, the middle one tending to be shield shaped. Scutellum usually entirely dark. Elytra densely but not very coarsely punctate, with short fine pubescence, sutural dark vitta nearly always uniting at apex with lateral vitta, the lateral vitta frequently having at apex a decurrent paler brown vitta running up, sometimes to the middle of the elytra. Body beneath with breast and abdomen, except at the tip, dark, legs pale, except the darker claw joint. Length 6-9.5 mm; width 2.6-3.5 mm.

*Type* male and 90 paratypes, U.S.N.M. no. 61129. Four paratypes in M.C.Z.; 5 paratypes in British Museum, taken on sagebrush, *Artemisia tridentata*, August 1, 1938, by O. V. Smith at Aztek, N. Mex.

*Remarks*.—The dark ventral surface and shiny prothorax distinguish this species from *T. lewisii* Crotch. It is one of the few larger western species with a dark undersurface.

*Disonycha barberi*, n. sp.

Fig. 10

From 5.4 to 6.6 mm in length, oblong oval, shining, pale yellow, the head with a broad dark occipital band extending in a point down the front and about the eyes and sides, the elytra with a sutural and marginal dark vitta uniting at apex and a median vitta, legs dark at apex of femora and the tibiae and tarsi entirely dark, beneath with the breast dark. Eyes unusually large, antennae dark with the tip paler.

Head shining, the polished dark occipital band finely punctate on the occiput and front and extending in a peak down to tubercles, also about the eyes and down the side of the head, the mouthparts dark; eyes unusually large, the interocular space being less than half the width of the head, a fovea on each side near eye composed of punctures; tubercles pale and well marked, carina between antennal sockets not very wide or produced but rounded. Antennae dark with the three basal and 2 apical joints more or less pale. Prothorax about twice as wide as long at base with rounded sides, somewhat depressed over the scutellum, entirely pale with very faintly punctate surface, shining. Scutellum dark, triangular. Elytra shining, more distinctly punctate, pale with a moderately wide sutural and marginal vitta joined at apex, median vitta moderately wide, epipleura wide and dark but diminishing and vanishing before the apex. Body beneath with the breast more or less darkened, the apices of the anterior pairs of femora narrowly and those of the posterior femora more widely dark, the tibiae and tarsi dark. Length 5.4-6.6 mm; width 3-3.3 mm.

*Type* male and 20 paratypes, U.S.N.M. no. 61130. Two paratypes in M.C.Z., 1 paratype in British Museum, collected at Brownsville, Tex., four specimens on September 16, 1939, on *Condalia obovata* and the rest in June 1945 and September 1944 by J. D. Smith, who reared them from *Phaulothamnus spinescens*.

*Other localities*.—San Bonito, Tex., on corn foliage, March 27, 1945; Sebastian, Tex., April 24, 1945; 1 specimen trapped at airport, Brownsville, June 6; 1 specimen taken from the cabin of a plane "in Mexico," June 26, 1947.

*Remarks*.—This species had been labeled by Mr. Barber with two different new specific names, the first one from its resemblance to *D. glabrata* (Fabricius), the second from its food plant. Both names are somewhat awkward-sounding, and so I propose to name it after Mr. Barber whose glee on discovering it I well remember. In general markings it resembles closely *D. glabrata*, but the unusually large eyes and different pattern of the head markings at once distinguish it. None of the specimens has any pronotal dark spots such as are usual in *D. glabrata*. Both larvae and eggs were sent in by J. D. Smith, who reared it from *Phaulothamnus spinescens*.

*Disonycha arizonae* Casey

Fig. 8

Some years ago Dr. E. C. Van Dyke sent me four specimens (three females and one male) of a *Disonycha* from the collection of the California Academy of Sciences, with the label Elmwood, Tenn., Fenyess Coll. At first sight it seemed to be something new, but the label reminded me of a series in the U. S. National Museum with the

same locality label that were typical specimens of *D. arizonae* Casey, and on comparison I found these four to be simply a dark color form of that species. This was corroborated by examination of the male genitalia. In all four specimens the elytra were deep reddish brown or piceous with a narrow pale margin, and in all four there was a faint trace of vittation at the apex, in the darkest specimen, only a tiny pale spot but in the others, showing very faintly, two pale vittae.

ZOOLOGY.—*Geographical distribution of the nemerteans of the northern coast of the Gulf of Mexico as compared with those of the southern coast of Florida, with descriptions of three new species.* WESLEY R. COE, Scripps Institution of Oceanography.<sup>1</sup> (Communicated by W. L. Schmitt.)

Up to the present time no published information has been available relative to the nemerteans of the areas covered by this report. Consequently it has been uncertain whether the nemertean fauna might be found to consist principally or wholly of species identical with those of the Atlantic coast or whether the more typically tropical or subtropical species would be included. Nor was it known whether any or many apparently endemic forms might be present.

Twenty-two species have now been identified. Sixteen of these are found on the northern coasts of the Gulf and six others in southern Florida. Only two specimens from the deeper, off-shore waters of the Gulf have been obtained by the writer. Both of these belong to either *Lineus* or *Micrura*, but the specimens were not sufficiently well preserved to allow specific analysis. No information is yet available for all that portion of the western Gulf coast south of the Mexican border, or for any locality on the west coast of the Florida peninsula between Franklin County and Key West.

The presumable explanation for the small number of species at present known is that only sporadic efforts have been made toward a complete survey of the littoral fauna of the Gulf. On the Atlantic coast of North America there are 53 known species of nemerteans and on the Pacific coast 95 species. Hence it seems probable that there are many more

species now actually living in the Gulf than can be included in this report.

Even on the Atlantic coast the nemerteans have been studied extensively only as far south as New Jersey, and our knowledge of the species living between that State and Florida is based on collections made at widely separated localities. It may therefore be assumed that some, perhaps many, additional species remain to be discovered there.

All except two of the species known from the northern part of the Gulf are also found on the Atlantic coast. Therefore, it seems probable that the nemertean fauna of the northern Gulf coast has in the past been a continuation of that of the Atlantic coast and that it is now a separate fauna that was isolated in Pleistocene times by the Florida Peninsula. To determine whether any of the populations of the two areas are at present continuous, it is essential to obtain additional collections on both sides of the southern half of that peninsula. It is already known that the species found at Pensacola, on the Gulf side, are similar to those found by the writer personally at St. Augustine, on the Atlantic side. The following lists, however, indicate that these two nemertean faunas are separated by an area in which other species predominate.

Because the nemerteans of the northern Gulf coast are generally of different species than those at present known from southern Florida, the species of the two areas will be listed separately.

<sup>1</sup> Contribution from the Scripps Institution of Oceanography, new series, no. 539.



I. GEOGRAPHICAL DISTRIBUTION OF SPECIES  
AT PRESENT KNOWN FROM THE NORTHERN  
COAST OF THE GULF OF MEXICO

[Abbreviations indicate: A, Atlantic coast of North America; E, coasts of Europe; G, Northern coast of the Gulf of Mexico; P, Pacific coast of North America; S, southern Florida; W, West Indies; X, at other localities.]

Order 1, PALEONEMERTEA

Family Tubulanidae

*Tubulanus pellucidus* (Coe), 1895. A, G, P.

Family Carinomidae

*Carinoma tremaphoros* Thompson, 1900. A, G.

Order 2, HETERONEMERTEA

Family Lineidae

*Zygeupolia rubens* (Coe), 1895. A, G, P.

*Lineus socialis* (Leidy), 1855. A, G.

*Micrura leidyi* (Verrill), 1892. A. G. S.

*Cerebratulus lacteus* (Leidy), 1851. A, G.

Order 3, HOPLONERMERTEA

Family Emplectonemertidae

*Paranemertes biocellata* Coe, 1944. G.

Family Carcinonemertidae

*Carcinonemertes carcinophila* (Kölliker), 1845. A, E. G.

*Carcinonemertes carcinophila imminuta* Humes, 1942. G, S, W.

Family Proserhochmididae

*Oerstedtia dorsalis* (Abild.), 1806. A, E, G, P, X.

Family Amphiporidae

*Zygonemertes virescens* (Verrill), 1879. A, G, P.

*Amphiporus cruentatus* Verrill, 1879. A, G, P.

*Amphiporus ochraceus* (Verrill), 1873. A, G.

***Amphiporus texanus*, n. sp.**

This new species represents one of the larger and broader forms of this extensive genus. The type specimen was about 60 mm in length and 6 mm in width after preservation. The length of this specimen is therefore only 10 times the greatest width. The head is narrow, about 2 mm in width, with subterminal mouth and transverse or oblique lateral grooves. There are many small ocelli on each side of the head, although the exact number and arrangement could not be determined in this specimen.

The proboscis is large and extends nearly the entire length of the body. The central stylet is moderately slender and about two-thirds of the length of the relatively massive basis. The latter is nearly rectangular in outline, about four times as long as its diameter, tapering but slightly toward the anterior end and is truncated pos-

teriorly (Fig. 1). In this type specimen the basis measured 0.135 mm in length and from 0.027 to 0.035 in diameter. One of the two accessory pouches contained two well-formed stylets and the other had three, two of which were not yet completed. In this specimen there were 10 rather large proboscisial nerves.

No record is available regarding the color in life, but the specimen preserved in formalin indicated a pale, reddish-brown epidermal pigmentation. The cerebral sense organs are comparatively larger than in most species of the genus. They are situated lateroventrally and a short distance anterior to the brain.

This specimen (U.S.N.M. no. 22965) was collected by B. Earp at Port Aransas, Tex. All the other species of nemerteans at present known from that locality are found also on the North Atlantic coast. Consequently it is uncertain whether this new species is limited to the Gulf of Mexico or whether it may occur also on the Atlantic coast, although it has not yet been found there.

Family Tetrastemmatidae

*Tetrastemma candidum* (Müller), 1774. A, E, G, P, X.

*Tetrastemma vermiculus* (Quatr.), 1846. A, E, G.

Order 4, BDELLONEMERTEA

Family Malacobdellidae

*Malacobdella grossa* (O. F. Müller), 1776. A, E, G, P.

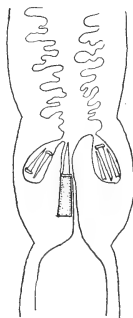

FIG. 1.—*Amphiporus texanus* n. sp.: Outline of stylet apparatus of proboscis.

II. SPECIES AT PRESENT KNOWN FROM  
SOUTHERN FLORIDA

Order 1, PALEONEMERTEA

*Tubulanus floridanus*, n. sp.

In the collections from Biscayne Bay, Fla., was one specimen of *Tubulanus* that evidently represents a previously undescribed species. This specimen is very slender, about 40 mm in length and only 1 to 2 mm wide. The color in life is brown, with a series of about 30 very narrow rings of lighter color. Nearly all the rings completely encircle the body. Anteriorly the rings are separated by a distance about equal to the diameter of the body but more posteriorly they are generally more widely separated and irregularly spaced. The lateral sense organs can be distinguished externally but are not conspicuous.

Transverse sections show a rather thick outer epithelium, with a thin, but dense, basement layer and an unusually large median dorsal nerve. The cerebral sense organs are large and highly specialized, with a sensory canal leading laterally to the surface of the epithelium.

Individuals of this species have a superficial resemblance to those of *T. annulatus* (Montague), *T. capistratus* Coe, and *T. nothus* (Bürger) but are without longitudinal lines of contrasting color.

One individual of this species was collected by F. M. Bayer among algae on dock piling on the County Causeway at Miami, Biscayne Bay, Florida. U. S. Nat. Mus. Cat. No. 22251.

Order 2, HETERONEMERTEA

Family Lineidae

*Lineus ater* (Girard), 1851. S, W.

*Lineus stigmatus* n. sp.

The collections contained fragments of an undescribed species of this genus, but unfortunately the head was not among them. Nevertheless the markings on the body are so distinctive as to indicate that these fragments could not have belonged to any of the numerous described species. It seems necessary therefore to give as complete a diagnosis of a new species as is possible in the absence of the head.

The fragments have a maximum width of 5 mm, tapering to about 2 mm at the posterior end, indicating that the entire individual would have had a length of 150 mm or more.

The color in life was slaty brown on both dorsal and ventral surfaces, with paired transverse white

markings at intervals of 1 to 2 mm on the dorsal surface. Each narrow marking is about one-fifth the diameter of the body in length and the two members of each pair are separated from the margin and from each other by about the same distance (Fig. 2). The markings are limited to the dorsal surface and become irregular and indistinct toward the posterior end of the body. The colors are retained after preservation in alcohol.

Since the anterior end of the body was not obtained, nothing can now be said as to the presence of ocelli, the character of the cephalic grooves or other sense organs or the peculiarities of the nephridia. Transverse sections of the body show an unusually thick cutis with many spiral muscular fibers and a heavily pigmented layer externally.



FIG. 2.—*Lineus stigmatus* n. sp.: Outline of posterior portion of body, showing position of white markings. The markings appear to be irregularly spaced, owing to differences in state of contraction.

The paired markings in this species have a superficial resemblance to those of some individuals of *L. geniculatus* (D. Chiaje) in which the white rings are interrupted in the mid dorsal line but in the latter species the rings continue laterally and ventrally. There is also some resemblance to *L. albocinctus* Verrill, recorded from Bermuda and Puerto Rico, although in that species the transverse lines are continuous on the dorsal surface and the ventral surface of the body is whitish.

The species is at present known only from the fragments of one individual collected by G. S. Posner on the shore of Biscayne Bay, Fla. U.S.N.M. no. 22252.

*Micrura leidy* (Verrill), 1892. A, G, S.  
*Cerebratulus fuscus* McIntosh, 1873. E, S, X.  
*Cerebratulus leucopsis* (Coe), 1902. S, W.

## Order 3, HOPLOMERTEA

## Family Amphiporidae

*Carcinonemertes carcinophila* var. *imminuta*  
Humes, 1942. G, S, W.

## Family Drepanophoridae

*Drepanophorus crassus* (Quatr.), 1846. E, P, S,  
W. X.

## SUMMARY

The preceding lists show that many of the species have a remarkably wide geographical distribution already recorded and it may be expected that they will later be found elsewhere. Of the 16 species at present known from the northern Gulf coast, all except *Paranemertes biocellata* and *Amphiporus texanus* are widely distributed on the American Atlantic coast, and four of them, namely, *Tubulanus pellucidus*, *Zygeupolia rubens*, *Zygonemertes virescens*, and *Amphiporus cruentatus*, occur also on the Pacific coast but not in Europe; two others, *Carcinonemertes carcinophila* and *Tetrastemma vermiculus*, are found on American Atlantic and European coasts but not in the Pacific; *Oerstedtia dorsalis* and *Tetrastemma candidum* are circumpolar, being distributed along both the east and west Atlantic and Pacific coasts; *Malacobdella grossa* occurs on both American coasts and in Europe; while the remaining five species, *Carinoma tremaphoros*, *Lineus socialis*, *Micrura leidyi*, *Cerebratulus lacteus*, and *Amphiporus ochraceus* are known only from the Atlantic and Gulf coasts.

ZOOLOGY.—A new species of marine nematode, *Thoracostoma magnificum*, with a note on possible "pigment cell" nuclei of the ocelli. R. W. TIMM, The Catholic University of America. (Communicated by E. G. Reinhard.)

The species of nematode described in this paper was collected from rocks at Point Barrow, Alaska, and sent to Dr. B. G. Chitwood at The Catholic University of America, Department of Biology, for identification. It is here described and figured as a new species of the family Enoplidae, subfamily Leptosomatinae:

***Thoracostoma magnificum*, n. sp. Fig. 1**

*Description*.—Large worms with an elongate filiform body. Well-developed cephalic helmet ( $38\mu$  long); slits in the posterior grooves of the

*Paranemertes biocellata* and *Cerebratulus texanus* have been found only on the northern Gulf coast and may possibly represent endemic species.

Of the seven species herein recorded from southern Florida, only two are known to occur both on the northern Gulf coast and in southern Florida, while *Lineus ater* and *Cerebratulus leucopsis* have been previously reported from Puerto Rico and Curaçao. *Cerebratulus fuscus* occurs also in northern Europe and South Africa, while *Drepanophorus crassus* has an almost world-wide distribution. *Tubulanus floridanus* and *Lineus stigmatus* are at present known only from Biscayne Bay, Fla.

For comparison, it may be noted that 11 of the 53 species found on the North American Atlantic coast are identical with species in European waters, while 12 of the Atlantic coast species occur also on the Pacific coast and 2 of these extend also to Japan. No less than 18 of the species found on the Pacific coast are thought to be identical with well-known European species and others are closely similar.

## REFERENCES

- COE, W. R. *Biology of the nemerteans of the Atlantic coast of North America*. Trans. Connecticut Acad. Arts and Sci. **35**: 129-328. 1943.  
———. *Geographical distribution of the nemerteans of the Pacific coast of North America, with descriptions of two new species*. Journ. Washington Acad. Sci. **24**: 27-32. 1944.

helmet not joined. Amphids pocketlike, open—within a ring formed by the helmet;  $7.5\mu$  wide in both male and female, one-ninth as wide as the cephalic diameter. Ten cephalic setae in the external circle, four of which are double; six setae in the internal circle. Dorsal tooth very inconspicuous. Dentiform projections in front of the helmet. No excretory pore or subventral excretory gland cell. Ocelli ( $19\mu$  in diameter) with red-pigmented "retina" and crystalline lens. Cuticle  $12\mu$  at the head and tail,  $8\mu$  at the mid-body. Nerve ring 30 percent of the esophageal length from the anterior in both sexes.

*Male*.—24 mm long;  $\alpha$ , 98.4;  $\beta$ , 9.3;  $\gamma$ , 189. Length of spicules  $264\mu$ ; length of gubernaculum: corpus  $125\mu$ , crus  $82.5\mu$ . Total length of testes 33 percent of the body length. One preanal tuboid supplement situated ventrally and nine pairs of accessory papilloid supplements situated subventrally; nine pairs of submedian preanal and two pairs of submedian postanal papillae.

*Female*.—24 mm long;  $\alpha$ , 98.4;  $\beta$ , 9.3;  $\gamma$ , 190. Vulva 64.4 percent from the anterior; both ovaries 31.5 percent of the body length; ovaries reflexed. Two eggs in the uterus,  $224\mu$  by  $780\mu$ .

*Habitat*.—Marine.

*Locality*.—Point Barrow, Alaska.

*Specimens*.—U.S.N.M. no. 131883 (cotypes).

*Remarks*.—Filipjev (1916) separated the new

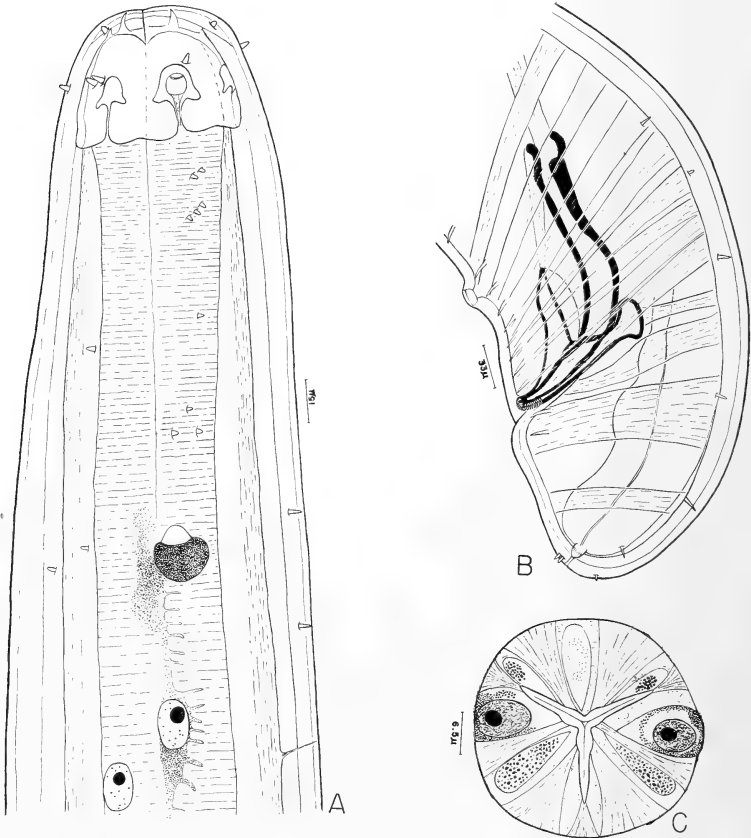

FIG. 1.—*Thoracostoma magnificentum*, n. sp.: A, anterior end; B, male tail; C, cross section through first two marginal nuclei of esophagus.

genus *Deontostoma* from *Thoracostoma* on the absence of "large dentiform projections in front." He characterized the genus *Thoracostoma* as having "a hollow ventral tooth." Although *Thoracostoma magnificum* does not have conspicuous teeth as seen in totemount preparations, yet in cross section a definite dorsal tooth, through which the dorsal esophageal gland duct opens, is found to be present. There are also dentiform projections in front. The genus *Deontostoma* has not been generally accepted.

A NOTE ON POSSIBLE "PIGMENT CELL"  
NUCLEI OF THE OCELLI

Nothing has ever been observed on the innervation of the ocelli of nematodes. Schulz (1931) described a formative cell ("Bildungszelle") directly behind the ocellus of *Parasymplocostoma formosum* [? syn. of *Enchelidium marinum* (Müller, 1783) Ehrenberg, 1836]. He also described a canal ("Augenkanal") opening from the lens to the exterior. These observations have never been confirmed.

In *Thoracostoma magnificum* there are two large nuclei ( $11\mu$  by  $18\mu$ ) of the esophagus located a short distance behind the ocelli, which are half-embedded in the lateral walls of the esophagus (Fig. 1, A). These nuclei lie in accessory subventral gland ducts, which are filled with ocellus pigment granules, and lead to the eyes. They are the first two nuclei of the esophagus and

represent marginal nuclei ( $M_1$  and  $M_2$ ); they are surrounded by concentrations of ocellus pigment (Fig. 1, C). In *Leptosomatum elongatum* var. *acephalatum* Chitwood, 1936, and in *Thoracostoma figuratum* (Bastian, 1865) de Man, 1893, we have found these nuclei either in direct contact with the ocelli or a short distance behind them. Since the esophagus is a syncytium, the cytoplasmic boundaries of the cells producing the pigment have not been determined. However, since the regions in which the ocellus pigment extends throughout the esophagus are the same regions in which the marginal nuclei lie, it is suggested that the latter may function as the nuclei controlling pigment production. Possibly the two anteriormost marginal nuclei are specialized for activating the surrounding cytoplasm to produce the ocelli, while the others control the production of the diffuse pigment of the esophagus. However, nothing final can be stated at the present time about definite "pigment cell" nuclei which direct formation of the ocelli.

LITERATURE CITED

- FILIPJEV, I. *Les nématodes libres contenus dans les collections du Musée Zoologique de l'Académie Impériale des Sciences de Petrograd*. Ann. Mus. Zool. Acad. Sci. Petrograd **21**: 59-116, pls. 1-2. 1916. (Russian text; French title.)  
SCHULZ, E. *Betrachtungen über Augen freilebender Nematoden*. Zool. Anz. **95** (9/10): 241-244. figs. 1-3. 1931.

ZOOLOGY.—A second record of the polychaetous annelid *Potamethus elongatus* (Treadwell). E. and C. BERKELEY, Pacific Biological Station, Nanaimo, British Columbia. (Communicated by F. A. Chace, Jr.)

The only specimen hitherto recorded of the polychaetous annelid *Potamethus elongatus* (Treadwell) is in the collection of the U. S. National Museum (no. 5221). It was taken by the steamer *Albatross* in the Hawaiian region in 1902 and briefly described by Treadwell (1906) under the name *Potamilla elongata*. The specimen was later re-examined by Hartman (1942) and attributed to the genus *Potamethus*. It was said to be fragmentary, but the essential details were described.

We have recently been fortunate enough to acquire three specimens of the species, sent to us by Dr. Clifford Carl, of the British Columbia Provincial Museum, Victoria, to whom they had been given by H. E. Wyeth,

of the cableship *Restorer*. They were found on sections of the San Francisco to Manila cable brought up for repair. The length of cable involved lies in depths varying from 840 to 1,600 fathoms, about 1,000 miles east of Guam. The specimens are all in good condition and complete, though much contracted, particularly in the peristomial region. One was preserved completely enclosed in its tube, the others partially enclosed. The lengths are, respectively, 50 mm, 51 mm, and 45 mm, the width about 2 mm in each case. The branchial plume, the filaments of which are twisted together in all the specimens, makes up half, or a little more, of the over-all length.

The general appearance agrees with that

of the type species of the genus, *P. spathiferus* Ehlers, the outstanding characters being the high, oblique collar, unbroken dorsally or ventrally, but rising to a high, thickened and grooved, lobe on the dorsal side, the slender body, and the very long branchial filaments (Ehlers, 1887, pl. 54). The dorsal collar lobe varies considerably in appearance in each of the three specimens and is evidently mobile. The long peristomial region, which Ehlers shows for *P. spathiferus* and Hartman says is present in *P. elongatus*, is not apparent in our specimens, but this region is much wrinkled because of contraction and would, no doubt, appear as shown by Ehlers in extension. The branchial bases are slightly, but definitely, involute on the ventral side.

As Hartman points out, *P. elongatus* is definitely differentiated from *P. spathiferus* by the form of the spatulate setae, those of the former species having long mucrons, whereas in the latter they are very little developed. The asymmetry of the blades of these setae in *P. elongatus*, which she stresses, is not invariably present in our specimens; some correspond closely with her figure 15d, others are as symmetrical as shown in our Fig. 1 and by Treadwell (fig. 74), and every intergrade is represented. The form of the thoracic uncinus in our specimens is also not completely in accord with that shown by Hartman (fig. 1c) or by Treadwell (fig. 75). As we find them the stems curve very little or not at all and taper very slightly and gradually, the crests are somewhat higher, and the angle between the beak and neck is rather smaller (fig. 2). These differences may well be within the limits of variation.

The abdominal setae are of two kinds, long capillaries with very narrow blades and others much shorter with wide, flat terminal blades set at a slight angle to the shafts (fig. 3). The abdominal uncini are as shown in Fig. 4. The tubes are quite smooth, the walls very thin and fragile and coated with very fine mud.

Four species have been ascribed to the genus *Potamethus*, all from considerable depths. Of these *P. mucronatus* (Moore), *P. spathiferus* (Ehlers), and *P. elongatus* (Treadwell) seem to be sufficiently clearly differentiated (see Hartman, 1942). There

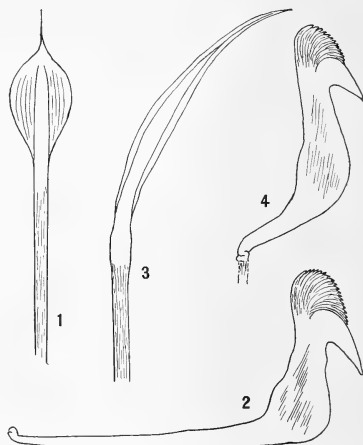

FIGS. 1-4.—*Potamethus elongatus* (Treadwell): 1, spatulate thoracic seta; 2, thoracic uncinus; 3, short abdominal seta; 4, abdominal uncinus.

remains *P. scotiae* Pixell. The only notable difference between this species and *P. elongatus* (Treadwell) appears to be in the form of the thoracic uncinus, particularly its very long stem and curious crest (Pixell, 1913, figs. 7a, 7b). Having regard to the variability of the setae in *P. elongatus* we have indicated, we consider it not improbable that the two species are synonymous.

One of the three specimens dealt with in this note is deposited in the U. S. National Museum (no. 22752); the others remain in the authors' collection.

#### LITERATURE CITED

- EHLERS, ERNST. *Florida-Anneliden*. Mem. Mus. Comp. Zool. 15: 335 pp., 60 pls. 1887.
- HARTMAN, OLGA. *The identity of some marine annelid worms in the United States National Museum*. Proc. U. S. Nat. Mus. 92: 101-140, 8 figs. 1942.
- PIXELL, HELEN L. *Polychaeta of the families Serpulidae and Sabellidae collected by the Scottish National Antarctic Expedition*. Trans. Roy. Soc. Edinburgh 49 (pt. 2): 347-358, 1 pl. 1913.
- TREADWELL, AARON L. *Polychaetous annelids of the Hawaiian Islands collected by the steamer Albatross in 1902*. Bull. U. S. Fish Comm. 23 (for 1903; pt. 3): 1145-1181, 81 figs. 1906.

MALACOLOGY.—A new brackish-water gastropod from Texas (*Amnicolidae: Littoridina*).<sup>1</sup> R. T. ABBOTT, U. S. National Museum, and H. S. LADD, U. S. Geological Survey. (Communicated by Julia Gardner.)

During the summer of 1940 the junior author made a study of the brackish-water and marine assemblages of the coastal waters in the vicinity of Rockport and Aransas Pass, Tex. Dredging was done from the bay-head areas near the mouths of streams, where the waters are nearly fresh, through the bays and passes to the Gulf of Mexico, where the waters are of normal marine salinity. The assemblages of mollusks and other benthonic organisms changed radically with the salinity gradient, and it was possible to recognize several distinct facies.<sup>2</sup> The fauna of the bay-head areas was found to be poor in numbers of species but, locally at least, rich in numbers of individuals. One of the most abundant forms is the species of *Littoridina* described in the present paper as the type of a new subgenus, *Texadina*. This new species was found alive only in water of low salinity, but a few worn or broken shells were dredged at intervals from more saline waters all the way to Aransas Pass at a point less than a mile from the open gulf.

#### Family AMNICOLIDAE

Genus *Littoridina* Eydoux and Souleyet, 1852

#### *Texadina*, n. subg.

Shell very small, minutely umbilicate, ovate-conic, with about five whorls, thin but strong. Whorls moderately convex, increasing regularly in size until the last third of the last whorl, which descends more rapidly, becomes constricted and in many specimens detached. Peristome oval to round. Surface smooth, except for fine growth lines. Suture fine, moderately impressed. Periostracum very thin, translucent gray. Operculum chitinous, paucispiral, thin, translucent. Radula and animal amnicolid-like. Type: *T. sphinctostoma* Abbott and Ladd. Recent, Texas.

The subgenus *Texadina* differs from *Littoridina* s.s. in having the peristome constricted and

more rounded, and in having the last third of the last whorl more rapidly descending.

#### *Littoridina (Texadina) sphinctostoma*, n.sp.

Figs. 1-12

*Description*.—Shell small (adults 2.0 to 3.3 mm in length), solid, ovate-conic to fusiform, very narrowly umbilicate, 5½ to 6½ whorls, translucent gray in fresh material to opaque white in dead specimens. Despite its rather fragile appearance, the shell is thick and strong. Apex moderately pointed, with smooth, glossy nuclear whorls not distinguishable from the postnuclear whorls. Sides of whorls moderately well rounded. Last third of the last whorl in most shells descends more rapidly and becomes constricted to form a relatively small, more rounded aperture than is seen in immature specimens. Peristome adnate or in some shells free from the parietal wall, usually thin and strong, but may be thickened either internally or externally. Umbilicus variable in size and shape, frequently deeply rimate or narrowly rounded. Suture sharp, well impressed. Spiral sculpture absent, except for a weak keel on the periphery of the last whorl in young specimens. Axial sculpture of very weak, widely spaced growth lines. Interior of shell highly polished. Periostracum very thin, smooth, translucent grayish to yellowish, lost in dead specimens.

Operculum very thin, chitinous, transparent yellowish, of size and shape of the aperture, and paucispiral. Radula taenioglossate with denticle

formula:  $\frac{3-1-3}{1-1}$ ; 2-1-3 or 3-1-3; 15 to 16 for the

inner marginal; 9 to 10 for the outer marginal. Animal with moderately short proboscis, moderately long tentacles, with the eyes located at the bases on slight swellings. Color unknown, but black pigment clusters seen above the eye, a vertical band of black-gray on the side of the foot, and a weak dusting of black along a wide band of the mantle edge. Vergé unknown.

#### MEASUREMENTS (mm)

Length	Width	Aperture	Whorls	U.S.N.M. no.
3.0	1.4	0.9 x 0.7	6.0	(holotype, 596722)
3.0	1.4	1.0 x 0.8	5.8	(paratype, 596723)
3.0	1.6	0.9 x 0.8	5.7	(paratype, " )
2.7	1.3	0.7 x 0.6	5.5	(paratype, " )
2.4	1.2	0.7 x 0.6	5.0	(paratype, " )

<sup>1</sup> Published by permission of the Secretary of the Smithsonian Institution and the Director, U. S. Geological Survey.

<sup>2</sup> A report on this work has been prepared and will be published by the Institute of Marine Science, University of Texas.

The accompanying graphs represent the shell lengths of adults from random samplings of three dredging stations. Shells in which the last part of the body whorl is constricted and descending are considered adult. Means: Station 2, 2.35 mm; station 3, 2.78 mm; station 6, 2.72 mm.

The number of individuals measured at the three stations is respectively 75, 104, and 101.

*Types*.—The holotype is U.S.N.M. no. 596722 from station 6. Paratypes from station 2 are in the U. S. National Museum (no. 596724), the Museum of Comparative Zoology (Harvard Col-

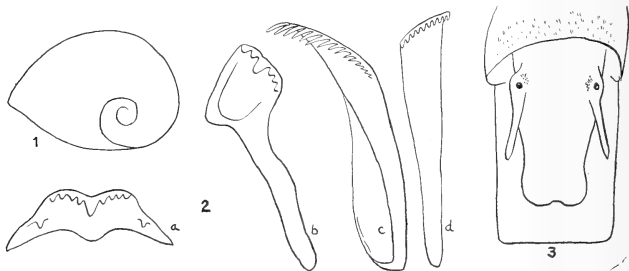

FIGS. 1-3.—*Littoridina (Texadina) sphinctostoma*, n.sp.: 1, Operculum; 2, radula, a, central, b, lateral, c, inner marginal, d, outer marginal (all greatly magnified); 3, dorsal view of animal ( $\times 20$ ).

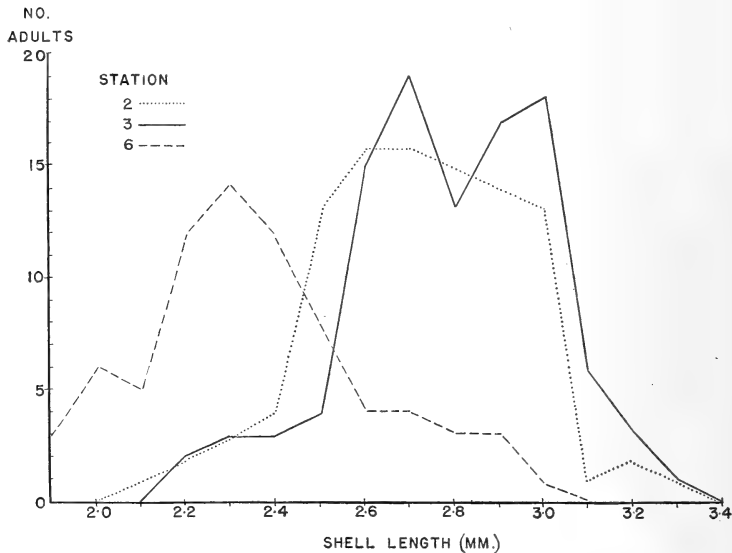
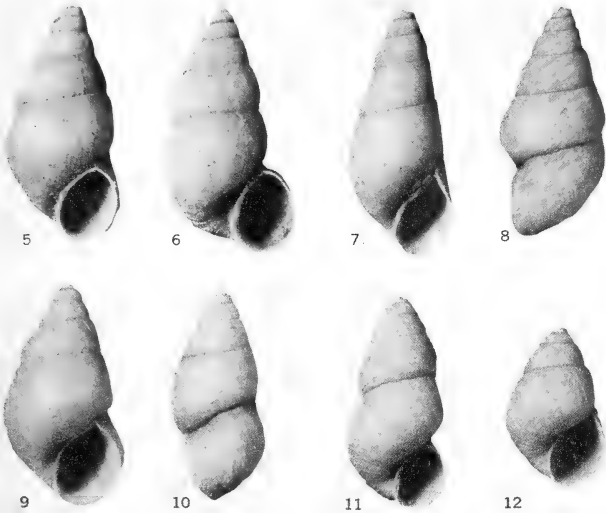

FIG. 4.—Graph of the shell lengths of adults from three population samples.





FIGS. 5-12.—*Littoridina (Texadina) sphinctostoma*, n.sp.: 5, Holotype; 6-12, paratypes. Fig. 12 is an immature specimen. (All  $\times 15$ ).

lege), the Academy of Natural Sciences of Philadelphia (no. 187519), the Museum of Zoology at the University of Michigan, and the Institute of Marine Science, University of Texas. Paratypes from the other stations are in the U. S. National Museum.

*Type locality*.—1½ miles north of Webb Point, northwest side of San Antonio Bay, 27 miles northeast of Rockport, Tex. H. S. Ladd, collected July 15, 1940, station 6.

*Locality records*.—See Table 1 for Texas material. At Grand Isle, La., four specimens were collected by A. G. Humes (U.S.N.M. no. 535757).

*Remarks*.—The size, texture, and general shape of the shells of *Littoridina sphinctostoma* are not unlike those of *L. tenuipes* Couper from the brackish waters of the Atlantic coast of southeastern United States. Our Gulf of Mexico species, however, is unique in the apertural constriction and the degree to which part of the last whorl descends and becomes detached. The small, oval peristome is rather like that found in *Stenothyra* and *Amphithalamus (Floridiscrobs) dysbatus* Pilsbry. However, *Littoridina sphinctostoma* does not

have the dorsal-ventral flattening of the body whorl of those two groups. Young specimens are of a normal littoridinid shape, although a few have a weak ridge at the periphery of the whorls. As shown in Figs. 5 to 12, there is considerable variation in the convexity of the whorls and the degree to which the last whorl descends or becomes detached from the body whorl. In many specimens the unusual change in the last part of the whorl is preceded by injury in some manner to the shell. In some adults, the spire may be slightly concave, giving the shell a fusiform shape. The shells from station 6 are much more variable in shape and are smaller in average size than those from other stations (see graph).

*Ecology*.—Living examples of *L. sphinctostoma* were recovered only at station 6, a locality at the head of San Antonio Bay about 40 miles from the open gulf at Aransas Pass. The salinity of the water at this locality, according to Galtsoff's map, is between 7 and 8 parts per thousand (Galtsoff, Paul S., *Survey of oyster bottoms in Texas*, Investigational Report No. 6, Bureau of

TABLE 1.—LOCALITY RECORDS (PARATYPES)

Station no. (H.S. Ladd)	Locality (all Texas)	Depth (feet)	Bottom	U.S.N.M. No.	Number of specimens
2	2 miles northeast of Austwell, head of Hynes Bay	2-2.5	Soft mud	596724	150±
3	3½ miles east of Austwell, Hynes Bay	3.5-4	Mud, sand, and shell	596725	200±
4	2 miles west of Seadrift, San Antonio Bay	2	Sand	596729	2
6	1½ miles north of Webb Point, San Antonio Bay	1.5	Muddy sand	596723 (type)	200±
20	South side of mouth of Copano Bay	3.6	Shell and muddy sand	596730	1
28	Southwest corner of San Antonio Bay	4	Muddy sand and shell	596731	2
39	East-central part of Copano Bay	1.5	Muddy sand and shell	596726	15
48	1½ miles east of Mud Island, Aransas Bay	7	Muddy sand and shell	596727	1
61	North side of main Aransas Pass	1-2	Rock jetty	596728	1

Fisheries, fig. 9, p. 15, 1931). Fresh shells were also dredged at three other localities. Two of these are in Hynes Bay, an arm of San Antonio Bay, at points (stations 2 and 3) where the salinity does not exceed 4 parts per thousand. The third locality where abundant shells were collected is in the exposed part of an oyster reef in Copano Bay (station 39), about 20 miles by airline southwest of the type locality. The salinity at this station may be as high as 19 parts per thousand; though abundant, the shells are not as fresh as those dredged in San Antonio and Hynes Bays.

At the type locality in San Antonio Bay the living snails were dredged from a bottom of muddy sand under 1½ feet of water. Associated with the snails are numerous living specimens of *Rangia cuneata* Gray (with attached barnacles), a few of razor clams (*Ensis minor* Dall), and *Mulinia lateralis* Say; also present are numerous Foraminifera: *Rotalia beccarii* (Linnaeus) was the

most abundant, with a few tests of *R. beccarii* var. *tepida* Cushman, *Nonion pauciloculum* Cushman, *Elphidium gunteri* var. *galvestonensis* Kornfeld, and *Miliammina fusca* (Brady).<sup>3</sup> The living faunas at stations 2 and 3, where abundant fresh shells of *Littoridina sphinctostoma* were found, are very similar to the living fauna of the type locality with the addition of ostracodes and numerous specimens of the thin-shelled *Tellina texana* Dall. The bay bottom at stations 2 and 3 is of soft mud under 2 to 3½ feet of water.

One or two shells were dredged from a third locality in Hynes Bay, and from localities in Copano Bay, Aransas Bay, and Aransas Pass. None of these was very fresh and most of them were worn or broken; they appear to have been transported appreciable distances from the place where they lived.

<sup>3</sup> Identifications of Foraminifera by Rita Post, of the U. S. Geological Survey.

ORNITHOLOGY.—*Observations on the genera of the swans.* ALEXANDER WETMORE, Smithsonian Institution.

The white species of swans superficially are so alike that there has been difficulty in the identification and application of the older generic names. It is now accepted that the type of the genus *Cygnus* Bechstein, 1803, is *Anas olor* Gmelin, the mute swan, not *Anas cygnus* Linnaeus, the whooper swan, as stated in the fourth edition of the A.O.U. Check-list.<sup>1</sup> In view of this change it is desirable to review the whole question of generic allocation in these interesting

birds. The latest comprehensive treatment of the living swans, that of James L. Peters, to which reference has been made, divides the seven living species between two genera, viz., *Chenopsis* for the black swan of Australia and *Cygnus* for the six remaining forms, of which five are found in the Northern Hemisphere, and one, the black-necked swan, ranges in the southern part of South America.

To outline the discussion, the fourth edition of the A. O. U. Check-list<sup>2</sup> recognized

<sup>1</sup> See PETERS, *Check-list of birds of the world* 1: 143, 1931; and WITHERBY et al., *Handbook of British birds* 3: 168, 1939.

<sup>2</sup> *Check-list of North American birds*, ed. 4: 35, 1931.

*Sthenelides* as the genus for the introduced mute swan, native in the Old World, found now in a feral state in the lower Hudson Valley and on Long Island, ranging in winter south to the coast of New Jersey and east to Massachusetts. The Twentieth Supplement to the Check-list<sup>3</sup> reduced *Sthenelides* to subgeneric status, thus placing all North American swans in one genus. Hildegarde Howard<sup>4</sup> has reopened this allocation by using *Sthenelides* as a genus for the fossil species named *Cygnus paloregonus* by Cope from the Pleistocene deposits of Fossil Lake, Oreg. (It may be observed that *Chenopsis atratus* of Australia seems marked generically from other swans mainly by the shorter tail, which is shorter than the middle toe with claw, and the naked lores in the downy young.)

Externally the species of white swans are so similar that the student of study skins has difficulty in separating them. The comparative anatomist, however, working with skeletons, has no trouble whatever in dividing them into two principal groups on characters so evident that they cannot be disregarded. The differences are most apparent in the form of the trachea, sternum, and furculum. Following is a summary of these anatomical characters, with indication of the allocation of the species of the Northern Hemisphere and South America:

a. Trachea passing directly into thorax, not entering sternum; furculum simple; tail cuneate ..... genus *Cygnus*

*Cygnus* Bechstein, Orn. Taschenb., pt. 2, 1803: 401. Type, by monotypy, *Anas olor* Gmelin.

*Sthenelus* Stejneger, Proc. U. S. Nat. Mus. 5: 184, 185. Aug. 5, 1882. Type, by monotypy, *Anas melancoripha* Molina. (Not *Sthenelus* Marschall, 1873, emendation for *Sthelenus* Buxquet, 1860, for a genus of Coleoptera.)

*Sthenelides* Stejneger, Auk 1 (3): 235. July 1884. Type, by monotypy, *Anas melancoripha* Molina. New name for *Sthenelus* Stejneger (pre-occupied).

*Euolor* Mathews and Iredale, Austr. Avian Rec. 3 (5): 117. Dec. 28, 1917. Type, by original designation, *Anas olor* Gmelin.

Species included:

*Cygnus olor* (Gmelin) (skeleton examined).

*Cygnus melancoriphus* (Molina) (skeleton examined).<sup>5</sup>

aa. Trachea making a loop that enters the sternum; furculum especially modified at symphysis to accommodate this loop; tail rounded ..... genus *Olor*

*Olor* Wagler, Isis, 1832: 1234. Type, by subsequent designation, *Cygnus musicus* Bechstein = *Anas cygnus* Linnaeus (Gray, 1840).

*Clangocygnus* Oberholser, Emu 8 (pt. 1); 3. July 1, 1908. Type, by monotypy, *Cygnus buccinator* Richardson.

b. Trachea entering anterior end of sternum smoothly, without a dorsal loop.

subgenus *Olor*.

Species included:

*Olor columbianus* (Ord) (skeleton examined).

*Olor cygnus* (Linnaeus) (skeleton examined).

*Olor bewickii* Yarrell.<sup>6</sup>

bb. Trachea making a dorsal loop as it enters sternum, protected by a bony case that projects into the anterior end of the body cavity ..... subgenus *Clangocygnus*

Species included:

*Olor buccinator* (Richardson) (skeleton examined).

The shape of the furculum and the looping of the trachea in the sternal keel are developed in the growing young, the loop lengthening and expanding to the end of the sternum as the individual becomes fully adult. This change with age has led to misunderstanding of the characters by some not familiar with it.

The arrangement of the genera above, it may be noted, is identical with that of Stejneger in his *Outlines of a monograph of the Cygninae*, published in 1882.<sup>7</sup>

In checking over the nomenclature concerned for the species in our list a curious

<sup>5</sup> Also the fossil species *Cygnus paloregonus* Cope. See HOWARD, Carnegie Inst. Washington Publ. 551: 160-165, Jan. 25, 1946, where *Cygnus matthewi* (Shufeldt) is placed as a synonym of *paloregonus*.

<sup>6</sup> See YARRELL, *History of British birds* 4: 320-322. 1884-85.

<sup>7</sup> Proc. U. S. Nat. Mus. 5: 174-221. 1882.

<sup>3</sup> Auk, 1945: 438.

<sup>4</sup> Carnegie Inst. Washington Publ. 551: 160-165. Jan. 25, 1946.

circumstance that does not seem to have been noted in ornithological literature has come to light relative to the generic name proposed by Stejneger for the black-necked swan. Stejneger in 1882 set up the generic name *Sthenelus* with a proper diagnosis of its characters. Apparently then his attention was drawn to Scudder's *Nomenclator zoologicus*, published in the same year where the following citation is found (p. 303): "*Sthenelus* Buq., col. 1859, M." Following this, two years later Stejneger,<sup>8</sup> in a discussion of Scudder's *Nomenclator*, in which he pointed out some of its shortcomings, wrote: "I find that the name *Sthenelus*, which I applied in 1882 to the black-necked swan from South America was preoccupied. It consequently requires a new one, and I propose in future to call the species *Sthenelides melanocorypha*."

Mainly through curiosity I checked the earlier use of *Sthenelus* to find that the reference is to Lucien Buquet in his "Mémoire sur deux genres nouveaux de Coléoptères de la famille des Longicornes (*Oxilus* et *Sthenelus*) suivi de la description appartenant aux genres *Platyarthron*, *Oeme* (*Sclerocerus* Dej.), *Clytus*, *Apriona*, *Cerosterna* et *Acanthoderus*."<sup>9</sup> The generic name in which we are interested is found on p. 621, where it has the same form as in the title, viz., *Sthenelus*, with the footnote "Nom mythologique." The subsequent history of Buquet's name so far as I have followed it is interesting.

<sup>8</sup> Auk, 1884: 235.

<sup>9</sup> Ann. Soc. Ent. France 7: 619-636. 1859 (1860).

Scudder, quoted above, took the name *Sthenelus* from Marschall's *Nomenclator zoologicus* of 1873 as indicated by the initial "M" in his citation. Marschall, on page 245, writes "*Sthenelus*, Buquet," with a reference to the original publication, but with no explanation for the emendation. On a little further research it is found that there is no mythological character from whom Buquet might have taken the term *Sthenelus*, while *Sthenelus* was a well-known name for several ancients of importance, among them a son of Perseus who became King of Mycenae, also a King of the Ligurians whose son Cynus was reputed to have been changed to a swan, and further one of the warriors who entered the wooden horse at the siege of Troy. It is not apparent whether Marschall recognized what we may consider Buquet's error consciously or unconsciously, but in either case he made the emendation. The matter is correctly set forth by Neave, in his *Nomenclator zoologicus*,<sup>10</sup> where he includes *Sthenelus* of Marschall, 1873, as a new name for *Sthelenus* Buquet, 1860. While it seems curious that neither Stejneger nor Richmond called attention to these matters in their notes on nomenclature, it is fairly certain that the circumstance must have been known to them because of their extensive knowledge and of their careful work in verification of references. In any event, *Sthenelus* of Marschall, 1873, antedated *Sthenelus* of Stejneger, 1882, so that the new name *Sthenelides* Stejneger of 1884 was in order.

<sup>10</sup> *Nomenclator zoologicus* 4: 309. 1940.

## Officers of the Washington Academy of Sciences

*President*.....NATHAN R. SMITH, Plant Industry Station  
*President-elect*.....WALTER RAMBERG, National Bureau of Standards  
*Secretary*.....F. M. DEFANDORF, National Bureau of Standards  
*Treasurer*.....HOWARD S. RAPPLEYE, U. S. Coast and Geodetic Survey  
*Archivist*.....JOHN A. STEVENSON, Plant Industry Station  
*Custodian and Subscription Manager of Publications*  
 HAROLD A. REHDER, U. S. National Museum

### *Vice-presidents Representing the Affiliated Societies:*

Philosophical Society of Washington.....EDWARD U. CONDON  
 Anthropological Society of Washington.....WALDO R. WEDEL  
 Biological Society of Washington.....  
 Chemical Society of Washington.....JOSEPH J. FAHEY  
 Entomological Society of Washington.....FREDERICK W. POOS  
 National Geographic Society.....ALEXANDER WETMORE  
 Geological Society of Washington.....LEASON H. ADAMS  
 Medical Society of the District of Columbia.....  
 Columbia Historical Society.....GILBERT GROSVENOR  
 Botanical Society of Washington.....E. H. WALKER  
 Washington Section, Society of American Foresters.....WILLIAM A. DAYTON  
 Washington Society of Engineers.....CLIFFORD A. BETTS  
 Washington Section, American Institute of Electrical Engineers  
 FRANCIS M. DEFANDORF  
 Washington Section, American Society of Mechanical Engineers.....RICHARD S. DILL  
 Helminthological Society of Washington.....L. A. SPINDLER  
 Washington Branch, Society of American Bacteriologists.....ANGUS M. GRIFFIN  
 Washington Post, Society of American Military Engineers.....HENRY W. HEMPLE  
 Washington Section, Institute of Radio Engineers.....HERBERT G. DORSEY  
 District of Columbia Section, American Society of Civil Engineers  
 MARTIN A. MASON

### *Elected Members of the Board of Managers:*

To January 1952.....W. F. FOSHAG, C. L. GAZIN  
 To January 1953.....C. F. W. MUESEBECK\*, A. T. MCPHERSON  
 To January 1954.....SARA E. BRANHAM, MILTON HARRIS\*

*Board of Managers*.....All the above officers plus the Senior Editor

*Board of Editors and Associate Editors*.....[See front cover]

*Executive Committee*.....N. R. SMITH (chairman), WALTER RAMBERG, H. S. RAPPLEYE,  
 J. A. STEVENSON, F. M. DEFANDORF

*Committee on Membership*.....L. A. SPINDLER (chairman), M. S. ANDERSON,  
 R. E. BLACKWELDER, R. C. DUNCAN, G. T. FAUST, I. B. HANSEN, D. B. JONES, DOROTHY  
 NICKERSON, F. A. SMITH, HEINZ SPECHT, ALFRED WESSLER

*Committee on Meetings*.....MARGARET PITTMAN (chairman), NORMAN BEKKEDAHL,  
 W. R. CHAPLINE, D. J. DAVIS, F. B. SCHEETZ, H. W. WELLS

### *Committee on Monographs:*

To January 1952.....J. R. SWALLEN (chairman), PAUL H. OEHSER  
 To January 1953.....R. W. IMLAY, P. W. OMAN  
 To January 1954.....S. F. BLAKE, F. C. KRACEK

*Committee on Awards for Scientific Achievement* (GEORGE P. WALTON, general chairman):  
 For the Biological Sciences.....G. H. COONS (chairman), J. E. FABER, JR.,  
 MYRNA F. JONES, F. W. POOS, J. R. SWALLEN

For the Engineering Sciences.....R. S. DILL (chairman), ARSHAM AMIRIKIAN,  
 J. W. MCBURNEY, FRANK NEUMANN, A. H. SCOTT

For the Physical Sciences.....G. P. WALTON (chairman), F. S. BRACKETT,  
 G. E. HOLM, C. J. HUMPHREYS, J. H. MCMILLEN

For Teaching of Science.....B. D. VAN EVERA (chairman), R. P. BARNES,  
 F. E. FOX, T. KOPPANYI, M. H. MARTIN, A. T. MCPHERSON

*Committee on Grants-in-aid for Research*.....L. E. YOCUM (chairman),  
 M. X. SULLIVAN, H. L. WHITTEMORE

### *Committee on Policy and Planning:*

To January 1952.....J. I. HOFFMAN (chairman), M. A. MASON  
 To January 1953.....W. A. DAYTON, N. R. SMITH  
 To January 1954.....H. B. COLLINS, JR., W. W. RUBEY

### *Committee on Encouragement of Science Talent:*

To January 1952.....M. A. MASON (chairman), A. T. MCPHERSON  
 To January 1953.....A. H. CLARK, F. L. MOHLER  
 To January 1954.....J. M. CALDWELL, W. L. SCHMITT

*Representative on Council of A. A. A. S.*.....F. M. SETZLER

*Committee of Auditors*.....J. H. MARTIN (chairman), N. F. BRAATEN, W. J. YODEN

*Committee of Tellers*.....W. G. BROMBACHER (chairman), A. R. MERZ, LOUISE M. RUSSELL

\* Appointed by Board to fill vacancy.

## CONTENTS

	Page
ASTRONOMY.—The birth of stars from interstellar clouds. LYMAN SPITZER, JR.....	309
ENTOMOLOGY.—New American chinch bugs (Hemiptera: Lygaeidae). CARL J. DRAKE.....	319
ENTOMOLOGY.—New species of chrysomelid beetles of the genera <i>Tri- rhabda</i> and <i>Disonycha</i> . DORIS H. BLAKE.....	324
ZOOLOGY.—Geographical distribution of the nemerteans of the northern coast of the Gulf of Mexico as compared with those of the southern coast of Florida, with descriptions of three new species. WESLEY R. COE.....	328
ZOOLOGY.—A new species of marine nematode, <i>Thoracostoma magnificum</i> , with a note on possible "pigment cell" nuclei of the ocelli. R. W. TIMM.....	331
ZOOLOGY.—A second record of the polychaetous annelid <i>Potamethus elongatus</i> (Treadwell). E. and C. BERKELEY.....	333
MALACOLOGY.—A new brackish-water gastropod from Texas (Amni- colidae: Littoridina). R. T. ABBOTT and H. S. LADD.....	335
ORNITHOLOGY.—Observations on the genera of the swans. ALEXANDER WETMORE.....	340

6.73  
2W

Lib

VOL. 41

NOVEMBER 1951

No. 11

# JOURNAL

OF THE

# WASHINGTON ACADEMY OF SCIENCES

## BOARD OF EDITORS

CHARLES DRECHSLER  
PLANT INDUSTRY STATION  
BELTSVILLE, MD.

WILLIAM F. FOSHAG  
U. S. NATIONAL MUSEUM

J. P. E. MORRISON  
U. S. NATIONAL MUSEUM

## ASSOCIATE EDITORS

J. C. EWERS  
ANTHROPOLOGY

C. W. SABROSKY  
ENTOMOLOGY

F. A. CHACE, JR.  
BIOLOGY

J. I. HOFFMAN  
CHEMISTRY

T. P. THAYER  
GEOLOGY

MIRIAM L. BOMHARD  
BOTANY

R. K. COOK  
PHYSICS AND MATHEMATICS

PUBLISHED MONTHLY

BY THE

WASHINGTON ACADEMY OF SCIENCES  
MOUNT ROYAL & GUILFORD AVES.  
BALTIMORE, MARYLAND

Entered as second class matter under the Act of August 24, 1912, at Baltimore, Md.  
Acceptance for mailing at a special rate of postage provided for in the Act of February 28, 1925.  
Authorized February 17, 1949

## Journal of the Washington Academy of Sciences

This JOURNAL, the official organ of the Washington Academy of Sciences, publishes: (1) Short original papers, written or communicated by members of the Academy; (2) proceedings and programs of meetings of the Academy and affiliated societies; (3) notes of events connected with the scientific life of Washington. The JOURNAL is issued monthly. Volumes correspond to calendar years.

*Manuscripts* may be sent to any member of the Board of Editors. It is urgently requested that contributors consult the latest numbers of the JOURNAL and conform their manuscripts to the usage found there as regards arrangement of title, subheads, synonymies, footnotes, tables, bibliography, legends for illustrations, and other matter. Manuscripts should be typewritten, double-spaced, on good paper. Footnotes should be numbered serially in pencil and submitted on a separate sheet. The editors do not assume responsibility for the ideas expressed by the author, nor can they undertake to correct other than obvious minor errors.

*Illustrations* in excess of the equivalent (in cost) of one full-page halftone are to be paid for by the author.

*Proof.*—In order to facilitate prompt publication one proof will generally be sent to authors in or near Washington. It is urged that manuscript be submitted in final form; the editors will exercise due care in seeing that copy is followed.

*Unusual cost* of foreign, mathematical, and tabular material, as well as alterations made in the proof by the author, may be charged to the author.

*Author's Reprints.*—Reprints will be furnished in accordance with the following schedule of prices (approximate):

Copies	4 pp.	8 pp.	12 pp.	16 pp.	20 pp.	Covers
100	\$3.25	\$6.50	\$ 9.75	\$13.00	\$16.25	\$3.00
200	6.50	13.00	19.50	26.00	32.50	6.00
300	9.75	19.50	29.25	39.00	48.75	9.00
400	13.00	26.00	39.00	52.00	65.00	12.00

*Subscriptions* or requests for the purchase of back numbers or volumes of the JOURNAL or the PROCEEDINGS should be sent to HAROLD A. REHDER, Custodian and Subscription Manager of Publications, U. S. National Museum, Washington 25, D. C.

*Subscription Rates* for the JOURNAL.—Per year..... \$7.50

Price of back numbers and volumes:	Per Vol.	Per Number
Vol. 1 to vol. 10, incl.—not available.*	—	—
Vol. 11 to vol. 15, incl. (21 numbers per vol.)	\$10.00	\$0.70
Vol. 16 to vol. 22, incl. (21 numbers per vol.)	8.00	0.60
Vol. 23 to current vol. (12 numbers per vol.)	7.50	0.90

\* Limited number of complete sets of the JOURNAL (vol. 1 to vol. 40, incl.) available for sale to libraries at \$341.00

MONOGRAPH NO. 1, "The Parasitic Cuckoos of Africa," by Herbert Friedmann. \$4.50

PROCEEDINGS, vols. 1-13 (1899-1911) complete..... \$25.00

Single volumes, unbound..... 2.00

Single numbers..... .25

*Missing Numbers* will be replaced without charge provided that claim is made to the Treasurer within 30 days after date of following issue.

*Remittances* should be made payable to "Washington Academy of Sciences" and addressed to the Treasurer, H. S. RAPPLEYE, 6712 Fourth Street, N.W., Washington 12, D.C.

*Exchanges.*—The Academy does not exchange its publications for those of other societies.



# JOURNAL OF THE WASHINGTON ACADEMY OF SCIENCES

VOLUME 41

November 1951

No. 11

ETHNOLOGY.—*Linguistic history and ethnologic history in the Southwest.*<sup>1</sup> GEORGE L. TRAGER, Foreign Service Institute, Department of State. (Communicated by W. N. Fenton.)

## I

In the Southwest of the United States we find among the pueblos not only a considerable ethnological variety but also a very great linguistic diversity; and there are peripheral nonpueblo peoples. It is useful to try to correlate the various factors, in the light of archeological evidence, for the purpose of setting forth a testable set of hypotheses.

The pueblos show the following linguistic affinities:

Uto-Aztecan: Hopi (most closely related linguistically to Paviotso).

Zunian: Zuni (an isolated language that shows structural resemblance to Tanoan, and may be tentatively considered as distantly related to that family).

Tanoan:

Tiwa (Taos, Picuris, Sandia, Isleta).

Tewa (Santa Clara, San Juan, San Ildefonso, Nambe, Tesuque).

Towa (Jemez).

Keresan:

Western: Acoma, Laguna.

Eastern: Santo Domingo, San Felipe, Santa Ana, Sia, Cochiti.

The extinct Pecos pueblo may have spoken Towa. Isleta del Sur was a colony of Isleta before it became hispanized, Pojoaque was Tewa-speaking, and the Piro and Tano of historic record were apparently Tiwa speakers. Tanoan and Uto-Aztecan are related, being subdivisions of Azteco-Tanoan (see

<sup>1</sup>Portion of an address delivered before the Anthropological Society of Washington on May 15, 1951.

Whorf, B. L., and Trager, G. L., *The relationship of Uto-Aztecan and Tanoan*, Amer. Anthrop. 36: 609-624. 1934). Zuni probably belongs here in some way. Keresan is almost certainly not related to these languages.

The nonpueblo peoples are: the Navahos and Apaches, who speak southern Athabascan languages; the Utes, Paiutes, Papago, Pima, Comanche, and Shoshoni, all of whom are Uto-Aztecan speakers; and to the east the Kiowa, the Caddo, and the extinct Texan tribes.

## II

Ethnologically the pueblos are divided thus:

Western: Hopi and Zuni. These are the "typical" pueblos in social organization and orientation; there are matrilineal clans, a theocracy, the practice of restraint in all interpersonal relations and in personal attitudes, an avoidance of violence, dislike of leaders and leadership, no desire for "progress" as such.

Central: Acoma and Laguna. Here there are clans, but also an important moiety division. The theocracy is strong, and violence and excess are decried; but there are leaders within this frame, and often extremely violent reactions and behavior in resisting change or intrusion.

Eastern and Rio Grande: The eastern Keresans, and all the Tanoan pueblos. There are no clans, moieties exist but break down in function in Taos and Picuris; the theocracy is still strong but functions in terms of secular leaders; leadership is decried, but personal leaders arise constantly; violence is not infrequent. Taos shows plains influences.

Archeologically the usual set-up for the region is about as follows (in very crude summary):

Anasazi (pueblo and pre-pueblo):

- A.D. 100- 500 Basket Maker—earliest types of houses; no pottery.  
 500- 700 Modified Basket Maker—villages; pottery.  
 700- 900 Pueblo I—better houses; good pottery.  
 900-1050 Pueblo II—spread in area.  
 1050-1300 Pueblo III—period of greatest development.  
 1300-1700 Pueblo IV—“renaissance”—new techniques.  
 1700- Pueblo V—acculturation and change.

It is believed that the Athabascans (Navahos, Apaches) arrived after 1300, acquiring many pueblo traits thereafter.

When we compare the archeological remains known as Hohokam, there is seen to be a parallel and not too dissimilar development up to 1400, after which the culture disintegrates. The modern Pima may be descendants of the peoples of this group. In a similar way the Mogollon cultures rose and then fell after 1400.

### III

The linguistic history of all these peoples can now be reconstructed in the manner below.

If Zuni is indeed part of the Azteco-Tanoan complex, the dates and relationships involved should pattern as in the following scheme:

This LINGUISTIC scheme may be further elaborated by suggesting that the speakers of Proto-Azteco-Tanoan were living in the area north of what is now the Southwest. By the beginning of the Christian Era a part of them were moving south in large numbers. These developed the Proto-Uto-Aztec language type, spreading quickly over the wide area, and reaching to central Mexico, with considerable linguistic proliferation and differentiation in the first few centuries of their movement. Some 500 years later, the stay-at-home Proto-Tano-Zunian speakers (the term is here used for the first time, to my knowledge) were afflicted by some urge to wander, and part of them went off. These reached the Southwest and made contact with the Modified Basket-Maker culture soon after leaving. The Proto-Kiowa-Tanoan speakers (another new term) remained behind, but after a few more centuries numbers of them separated from the main body and came into the Rio Grande area by 1000.

The Anasazi culture I conjecture to have developed among Keresan speakers. The impetus to its early development was possibly the coming of the Proto-Uto-Aztec groups from the north, serving as a kind of a catalyst. The Uto-Aztecs themselves took over, perhaps, the more advanced cultures—pre-Hohokam and pre-Mogollon—that they found, and developed them, probably replacing the original languages by Uto-Aztec languages of several kinds; the superseded languages may have been Yuman or Keresan (these two groups being possibly related). When the Proto-Zunians arrived, after 500, they found the Anasazi culture flourishing, and were incorporated into it, as one of the “typical” groups (Pueblo I).

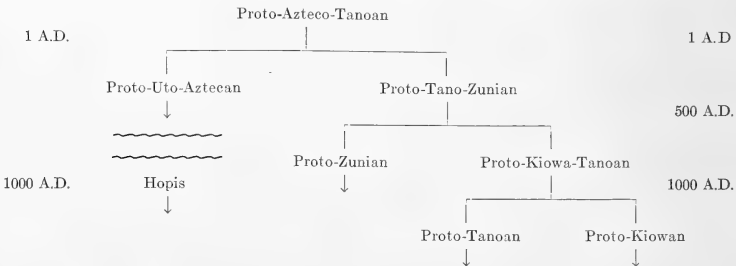

By the time the Tanoan speakers came in, they simply took over or were absorbed by numerous Keresan-speaking Pueblo III groups.

The chart showed the Hopi appearing at about 1000. The closest linguistic relatives of the Hopi are the Paviotso, with a simple hunting and gathering culture. Possibly the Hopis represent the result of a late arrival by Uto-Aztecan speakers who took over in its totality a going Pueblo II or III culture. There are no other Uto-Aztecan speakers among the pueblos, and these pre-Hopis may have belonged to one of the cultures from a little further south that later disintegrated.

In summary, I conjecture pueblo culture as originating and developing among Keresan speakers. The specific Western Pueblo traits of Hopi and Zuni represent a flowering and development due to a kind of hybrid vigor; Zuni was probably there first, and the Hopis borrowed from it or took over a Zunilike culture. Finally the Tanoans came late, and some of them (the Northern Tiwa) never did develop some of the more usual pueblo traits.

#### IV

The linguistic time scale above is not very great but is probably long enough to allow for the variations that are found. The development as given does not contradict the known facts of archeology and ethnology. The important dates fit in rather well with other important developments.

The reconstruction of linguistic history shows that the Kiowa and Tanoan relationship is distant enough to suggest that it goes back to a point before the Tanoans had acquired pueblo culture, and when they were probably much as the Kiowa were before they developed specific plains traits in the nineteenth century.

Again, Zuni and the Tanoans are both pueblo in culture, but their linguistic relationship is such—if real—that it goes much farther back than that of Kiowa and Tanoan.

Finally, the Hopi are so placed linguistically that they must have got the rest of their present culture from some non-Uto-Aztecan, or at least non-Hopian, predecessors.

#### V

The problems presented by such a scheme as the foregoing are numerous and difficult. At least the following kinds of studies must be made to test the hypotheses. There must be extensive linguistic description of all the pueblo and peripheral languages, i.e., of the whole Azteco-Tanoan group. So far there exist only the following studies: Whorf on Hopi, Kennard's unpublished material on Hopi, Bunzel's grammar of Zuni (but there is no dictionary), my work on Taos (partly published), and my unpublished work on Picuris, Isleta, and Sandia; E. C. Trager's work on Kiowa (not yet completed), a few minor papers on Keresan, Boas's Laguna texts (unanalyzed, and with no dictionary), and the publications of Harrington on various phases of Tewa and Kiowa ethnology and language. These needed studies of the languages as structures must be followed by studies of the vocabularies and comparison all around, to see if it can be determined who borrowed from whom.

A further possibility is the examination of the vocabularies for all kinds of terms for material and nonmaterial aspects of the culture, to see which are more original or structurally basic, and thus establish the linguistic appurtenance of the people who devised the trait or complex.

Finally there is the possibility that metalinguistic (see Trager, G. L., *The field of linguistics*, Studies in Linguistics: Occasional Paper no. 1. 1949) studies may reveal whether one or another of the linguistic structures is in any way especially appropriate to the other cultural habits of the several peoples involved (see Whorf, B. L., Four articles on metalinguistics, Washington, D. C., Foreign Service Institute, Department of State, 1950, for the pioneer work in this field of linguistic 'Weltanschauung').

PALEONTOLOGY.—*New Western Hemisphere occurrences of fossil selachians.*<sup>1</sup>

DAVID H. DUNKLE, U. S. National Museum.

The specimens here described are among those fossil toothlike structures generally interpreted as rostral spines of pristid sharks. In particular, they are referable to the genera *Onchosaurus* Gervais and *Propristis* Dames. Obtained, respectively, from Ecuador and Georgia, they are of interest because neither genus seems to have been reported previously outside of Europe and North Africa; and the meager record of fossil pristids in the Western Hemisphere is raised, thus, to a total of six genera.<sup>2</sup>

The present specimens of *Onchosaurus* were transferred to the National Museum by the U. S. Geological Survey and those of *Propristis*, through the kind offices of S. C. Lyons, by the Georgia Kaolin Co. of Dry Branch, Ga. It is a pleasure to acknowledge with gratitude the cooperation of both of these organizations. The illustrations accompanying this note were prepared by William D. Crockett, scientific illustrator of the division of vertebrate paleontology, U. S. National Museum.

***Onchosaurus* cf. *radialis* Gervais**

This genus is represented by three fragmentary spines (U.S.N.M. nos. 18111, 18112, and 18113). The structures are strongly compressed, dorsoventrally. They presumably projected directly out from attachment along the lateral edge of a rostrum with little or no upward or downward flexure. They were, however, deflected posteriorly in a frontal plane as indicated by their convex anterior and concave posterior margins.

The teeth are composed, characteristically, of an exposed crown covered with smooth, unornamented enamel, and an unenamelled inserted root. Although no one crown among the present examples is entire, projection of the preserved

edges shows this part to have had a triangular outline seen from either above or below, and to have occupied no more than one-third the longest axial dimension of the teeth. Proximally, at the anterior and posterior borders, the crown is slightly expanded to give an incipiently barbed appearance. Joining these barbs, the limit of enamel extends obliquely across the superior and inferior surfaces of the spine, arched in slight concavity toward the root. The free lateral edges of the crown are sharp.

In comparison with the reduced crown, the root portion of each spine comprises a notably long peduncle. This inserted part enlarges progressively from a thin, narrow distal neck adjacent to the crown to a maximum expansion at the proximal base. The peduncle is regularly ovate in section except near the base where the anterior and posterior margins are truncated. Here, the section is roughly quadrangular as is also the outline of the basal face. The sides of the root are marked by numerous coarse, alternating grooves and ridges which parallel the long axis of the spines. Those single anterior and posterior grooves are the most deeply incised but all are more pronounced proximally and tend to disappear distally. The furrows notch the circumference of the basal rim and are continuous with the ones radially arranged around the periphery of the shallow, elongate concavity occupying the proximal face of the root.

Measured in relation to its longest axis the best preserved spine (U.S.N.M. no. 18111, Fig. 1) possesses the following dimensions: total preserved length, 43.5 mm.; anterior height of root, 31.0; posterior height of root, 38.5; proximal width of root, 21.5; distal width of root, 11.5; proximal maximum thickness of root, 13.5; and distal minimum thickness of root, 6.0.

*Geological horizon and locality.*—Collected from the Upper Cretaceous (Turonian) on the left bank of the Rio Napo, one-fourth mile upstream from the village of Napo, Province of Oriente, Ecuador, by Joseph H. Sinclair and Theron Wasson, 1923.

*Remarks.*—The systematic and stratigraphic history of all the so-called ganopristine sharks was recently reviewed by Arambourg (1940). As treated therein, two subgeneric groups assigned a total of six previously described species from

<sup>1</sup> Published by permission of the Secretary of the Smithsonian Institution.

<sup>2</sup> The four genera of fossil pristids previously reported occurring in the Western Hemisphere are *Ischyrrhiza* Leidy, *Onchopristis* Stromer, *Pristis* Linck, and *Schizorhiza* Weiler (cf. DUNKLE, Journ. Washington Acad. Sci. 38: 173-176. 1948; HAY, Carnegie Inst. Washington Publ. 390: 603-604, 719. 1929; LOFGREN and OLIVIERA, Bol. Div. Geol. Misc., Rio de Janeiro, 106. 1943; ROMER, *Vertebrate paleontology*, ed. 2: 577. 1945; and WETZEL, *Palaeontographica* 73: 94-97. 1930).

various Upper Cretaceous horizons were defined and referred to the genus *Onchosaurus*. Specifically, there are: (1) a subgenus *Onchosaurus* s. str. containing the species *radicalis* Gervais (1852) and *pharao* Dames (1887); and (2) a subgenus *Ischyrhiza* with the species *mirus* Leidy (1856a), *antiquus* Leidy (1856b), *stromeri* Checchia-Rispoli (1933), and *maroconus* Arambourg (1935).

It will be noted that the above references include various departures from the usages originally given some of these generic and specific names. The six species assigned to *Onchosaurus*,

like the majority of other ganopristine forms, are based upon unassociated rostral spines. Stromer (1917, 1925, and 1927) has demonstrated wide variation in size and structure between individual teeth of the related and more adequately known sawfish, *Onchopristis*. It appears possible, therefore, that future discoveries of more complete remains of *Onchosaurus* may prove the changes in taxonomic concept proposed by Arambourg (1940) to have been premature. The attempted revision, however, serves an extremely useful basis for comparison, and in this connec-

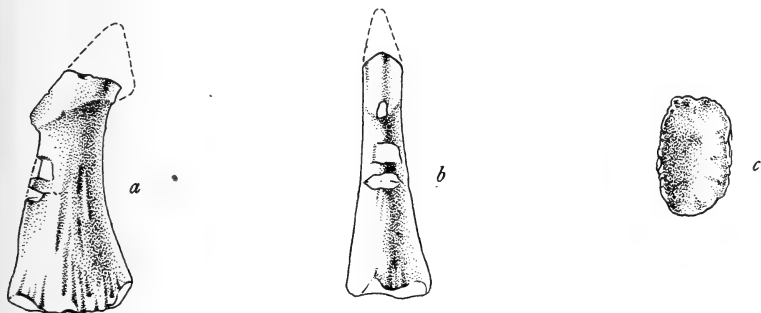

FIG. 1.—*Onchosaurus* cf. *radicalis* Gervais (U.S.N.M. no. 18111): Rostral spine from the Upper Cretaceous (Turonian) of Ecuador in (a) dorsal or ventral, (b) anterior, and (c) basal aspects. Approx.  $\times 1$ .

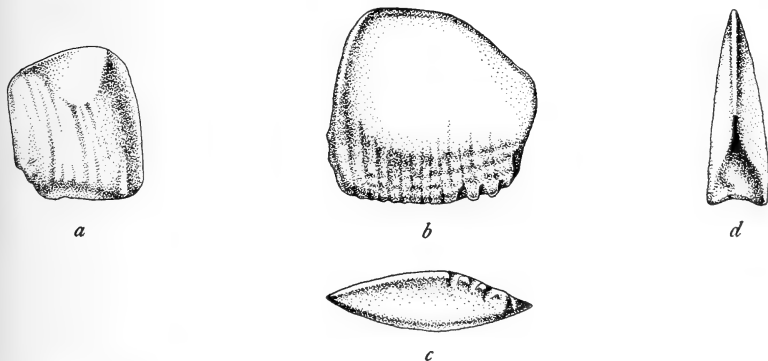

FIG. 2.—*Propristis* cf. *schweinfurthi* Dames: Rostral teeth from the upper Eocene (Jackson) of Georgia: (a) (U.S.N.M. no. 18216) in dorsal or ventral view; and (b, c, d) (U.S.N.M. no. 18215), respectively, in dorsal or ventral, basal, and anterior aspects. Approx.  $\times 2$ .

tion, the presently recorded spines from Ecuador clearly pertain to the subgenus *Onchosaurus* s. str. Further, they agree in most essential details with specimens identified as *radicalis* and lacking the flattened and axially grooved posterior root border characteristic of *pharao*, are tentatively referred to the former, genotypic species.

Individually the six referred members of the genus *Onchosaurus* are relatively restricted, stratigraphically, but collectively, they comprise a typical Upper Cretaceous assemblage, ranging from the Cenomanian to the Danian. The species *radicalis* has been reported from just two Senonian localities in France. The Ecuadorian specimens were collected with fragmentary materials of *Squatina* sp., *Acrotemna faba*, and indeterminate shark vertebrae and a pycnodontid tooth plate. The Turonian age of these vertebrate remains was established upon associated invertebrate fossils identified by Reeside (in Wasson and Sinclair, 1927).

#### *Propristis* cf. *schweinfurthi* Dames

Two unassociated but well-preserved specimens (U.S.N.M. nos. 18216 and 18215, illustrated in Fig. 2), exhibit the basic characteristics of all the rostral spines previously assigned to this particular fossil sawfish.

Both teeth are strongly compressed, dorso-ventrally, and viewed from either above or below, present irregularly quadrangular outlines. The forward border of each is the shortest of the four margins. Straight or even slightly concave in profile, this forward edge is flattened into a triangular area with broad, rugose proximal base tapering to a sharp distal apex. The entirely carinate posterior margin is weakly convex in profile and is the longest dimension exhibited by the teeth. From dorsal or ventral view, the basal margin is similarly convex, and the elliptical face of this inserted part is occupied by a shallow elongate concavity whose surface is roughened with the numerous openings of pores. The distal, exposed margin is in rounded confluence with both the anterior and posterior edges, and is rounded and polished smooth, apparently from functional wear.

Enamel as a tooth cap is absent. In consequence, the external textural appearance of the spines is reminiscent of that of the rostral teeth of *Pristis*. The upper and lower surfaces are marked by alternating low ribs and shallow grooves paralleling the longitudinal axes of the

structures. These are crossed by less distinct transverse ridges which tend to converge from the posterior border toward the anterior edge. Like the comparable markings on the bases of *Onchosaurus* spines, these features are more deeply pronounced on the proximal surfaces and disappear distally.

Measured in relation to the longest axes, the specimens have the following dimensions: greatest over-all length, 18.5 and 14.0 mm.; maximum over-all width, 20.25 and 13.25; width of base, 16.5 and 9.5; maximum thickness of base 5.5 and 4.5.

*Geological horizon and locality.*—Collected from strata of upper Eocene (Barnwell or lower Jackson) age exposed in quarries of the Georgia Kaolin Co. near Dry Branch, Twiggs County, Ga., by S. C. Lyons, 1948.

*Remarks.*—The two unassociated rostral spines of *Propristis* from Georgia can not be distinguished with certainty from those of the North African *P. schweinfurthi* and hence are referred to that species (Fraas, 1907).

These North American examples were found associated with other vertebrate remains, namely: teeth of *Carcharias*, *Isurus*, *Myliobatis*, and *Sphraena*; and fragments of the carapace and plastron of the turtle *Amyda*. The source horizon of this faunule is a stratum of sand and fullers earth immediately overlying the extensively quarried Tuscaloosa kaolins. According to a recently published stratigraphic section (La Moreaux, 1946), measured in the quarries of the Georgia Kaolin Co. in Twiggs County, this sediment may be assumed to be of lower Jackson age. In consequence a slight extension of the known range of *Propristis* is indicated since the genus has been reported only from the middle Eocene of Birket el Qurun, Egypt.

#### REFERENCES

- ARAMBOURG, C. *Note préliminaire sur les vertèbres fossiles des phosphates du Maroc.* Bull. Soc. Geol. France, ser. 5, 5: 413-440, pls. 19-20, figs. 1-2. 1935.
- . *Le groupe des Ganopristines.* Bull. Soc. Geol. France, ser. 5, 10: 127-147, pls. 3-4, figs. 1-12. 1940.
- CHECCHIA-RISPOLI, G. *Di un nuovo genere di Pristidae del Cretaceo superiore della Tripolitania.* Mem. R. Acc. d'Italia. Cl. Sc. Fis., Mat. e Nat., 4 (1): 6 pp., 1 pl. 1933.
- DAMES, W. *Ueber Titanichthys pharao, nov. gen., nov. sp., aus der Kriede formation Aegyptens.* Sitz. Gesell. Naturf. Freunde, Nr. 5: 69-72, 4 figs. 1887.

FRAAS, E. *Säge von Propriestis schweinfurthi Dames aus dem oberen Eocän von Ägyptens*. Neue Jahrb. für Min., No. 1: 1-6, pl. 1, figs. 1-3. 1907.

GERVAIS P., *Zoologie et paleontologie françaises* 2: 271, pl. 80. 1852. Paris.

LA MOREAUX, P. E. *Geology and ground-water resources of the Coastal Plain of east-central Georgia*. Georgia State Div. Conservation, Geol. Surv. 52: 1-173, pls. 1-2, figs. 1-21. 1946.

LEIDY, J. *Notice of remains of extinct vertebrated animals of New Jersey collected by Prof. Cook*. Proc. Acad. Nat. Sci. Philadelphia 8: 220-221. 1856.

———. *Notices of remains of extinct vertebrated animals discovered by Professor Emmons*. Proc. Acad. Nat. Sci. Philadelphia 8: 255-256. 1856.

WASSON, T., and SINCLAIR, J. H. *Geological explorations east of the Andes in Ecuador*. Bull. Amer. Assoc. Petr. Geol. 11 (12): 1253-1281, pls. 9-13, figs. 1-4. 1927.

ENTOMOLOGY.—*Phylogeny and biogeography of the caddisflies of the genera Agapetus and Electragapetus (Trichoptera: Rhyacophilidae)*.<sup>1</sup> HERBERT H. ROSS, Illinois Natural History Survey, Urbana, Ill.

An analysis of the phylogeny and distribution pattern of the small caddisflies belonging to the genus *Agapetus* and its allies has presented some interesting data on the movement of faunal elements between North America and Eurasia. For insects the time relations of this entire phase of distribution is poorly understood, although there is evidence in most groups of crossings between the parts of Holarctica. In the *Agapetus* group there is some evidence for placing such crossings in relation to geologic time.

The results of this study of the *Agapetus* line attest the fact that many small insect genera occupy a unique place in unraveling the phylogeny and morphogenetic steps in a large number of groups. This has been stressed by Emerson (1950) in his remarks on the objectivity of monotypic genera. In many instances these small genera are surviving members of early points in phyletic lines that have developed abundant faunas specialized far beyond these relicts. We are justified in regarding such archaic survivors as living fossils. In insect studies they are what we must use as a basis for phylogenetic deduction in theoretical areas of evolutionary speculation. In groups such as vertebrates and Mollusca, fossil evidence is used in this capacity.

It is my conviction that, by and large, insect groups possess more living fossils than vertebrate groups do true fossils and that, as a consequence, the entomologist has an unusual opportunity to contribute material

basic to the study of biogeography and evolution.

*Electragapetus* is one of those archaic genera of which, fortunately, we have available both a well-preserved fossil and two existing species. Its study establishes the order of origin of the distinctive characters of *Agapetus* and allows the dating of at least part of the associated phylogenetic development. With this as a basis a preliminary analysis has been attempted of the origin, divergence, and dispersal of the entire *Agapetus* complex.

#### THE AGAPETUS LINE

The genus *Agapetus* represents a phyletic line (Fig. 15) that arose from the genus *Anagapetus* and that is characterized in the adult primarily by a reduction and reorganization of the veins of the hind wing. The apex of development in these characters occurs in the *fuscipes* complex of the genus *Agapetus*.

In *Anagapetus* the front wing (Fig. 1) is much like *Rhyacophila*. The hind wing is also little changed from the primitive rhyacophilid type; its radial field (Fig. 6) has all branches present and the forks of  $R_s$  occur before cross-vein  $s$ ; and the anal veins are all present, with 1A and 2A forming an elongate fork. The genus *Catagapetus* represents the first steps toward *Agapetus*. In *Catagapetus* the front wing has lost vein  $R_{1+2}$ , and cross-vein  $r$  has become aligned with cross-vein  $s$  (as in Fig. 2); and in the hind wing (Fig. 7) cross-vein  $s$  has moved basad. Existing species show reductions of hind wing venation that have occurred in the *Catagapetus* line since it separated from the main *Agapetus* stem.

In *Electragapetus* (Fig. 8) the first major steps in specialization are seen: fork  $R_{2+3}$  has migrated

<sup>1</sup> This paper is a joint contribution from the Section of Faunistic Surveys and Insect Identification, Illinois Natural History Survey, and the Department of Entomology, University of Illinois.

close to the margin of the wing, fork  $R_{4+5}$  has migrated a short distance in the same direction, and cross-vein  $s$  has migrated closer to the basal fork of  $R_6$ . The more primitive existing species of *Agapetus*, such as the species *dubitans*, exhibit a marked change in this hind wing pattern (Fig. 9). Beyond cross-vein  $r$ ,  $R_1$  is reduced to a short, oblique section fusing with  $Sc$ ; the basal part of  $R_1$ ,  $r$ , and  $R_{2+3}$  beyond  $r$ , have realigned to form a serial vein with a slight dip on the part of the vein composed of  $r$ ; cross-vein  $s$  has completely disappeared; and  $R_{4+5}$  branches much closer to the wing margin. This early point in *Agapetus* development is called the *Synagapetus* stage, and its origin is labeled S.S. in Fig. 15.

Between the *Electragapetus* stage and the *Agapetus* stage of evolution of the radial veins, a second development of the hind wing venation took place. In *Anagapetus* and *Electragapetus* (Fig. 6) vein 3A is short and free, running into the margin of the wing. In *Agapetus* (Fig. 9) it appears to have turned up at the end and run into vein 2A just beyond cross-vein  $a$ . The short stub projecting from the curved connection, however, may actually be the tip of 3A and the connecting portion may be an adventitious spur or branch that has developed as a cross brace. Following this interpretation, when the stub is present it is labeled 3A and the connecting piece 3A'; when the stub is absent the vein is labeled simply 3A.

After the change began in the anal veins, reduction still continued in the anterior veins, involving first a complete loss of the oblique section of  $R_1$  running from  $r$  to  $Sc$ , and then both a coalescence of  $Sc$  with the anterior margin, and continued movement of the forks of  $R_6$  toward the wing margin. The end of this direct line is represented by the European *fuscipes* (Fig. 13) in which all but the base of  $Sc$  has coalesced with the anterior margin, fork  $R_{2+3}$  has become completely obliterated, and fork  $R_{4+5}$  is very close to the wing margin. Throughout this series little change occurs in the front wing or in the anal region of the hind wing. This sequence of reduction of venation has proceeded independently in several distinct phyletic lines within *Agapetus*, and reached various stages in different lines.

A somewhat similar situation exists regarding the male genitalia in the *Agapetus* complex. From at least the origin of *Electragapetus*, the ancestral form of genitalia has had single segmented clasp-

ers, the tenth tergite divided into a pair of vertical, platelike, and only partially sclerotized lobes, and at the base of each lobe a fingerlike, projecting cercus bearing an irregular row of long setae (Fig. 23A). Differences in genitalia between most of the species involve chiefly differences of proportion or addition of ornamentation to this general basic type. That is, in one species the tenth tergite may be long, in another species short; or in one species the clasper may have a mesal spur, in another none. In certain lines, however, there is a marked reduction of the cercus, and in a few lines this structure has completely disappeared. Judged from evidence from other structures, the same modifications have arisen independently in different lines.

#### PHYLETIC BRANCHES OF AGAPETUS

Evidence indicating the first major division of *Agapetus* is found in a curious pair of organs occurring one on each lateral portion of the fifth sternite of the males. In some species this organ is internal and forms an oval or round cavity opening by a narrow slit to the outside. Its function is probably olfactory or auditory. Beginnings of this organ are found in some of the primitive species placed in the subgenus *Synagapetus*, such as *dubitans* and especially *iridipennis*, in which an invagination is present beneath a ridge on the side of the fifth sternite. The organ is present as a well-developed structure in many of the European species and all the American species, but absent in all the Japanese and East Pacific Island species I have seen.

This latter group of Oriental species thus appears to be an independent evolutionary line, starting from a primitive species of *Synagapetus* representing a stage before the lateral male organ had begun to develop. The genitalia have remained primitive in essential respects throughout the line, but the hind wing venation has become progressively reduced to the condition found in *curvidens* (Fig. 14) in which not only radius but also the branches of media are greatly reduced. This complex of species I am calling the *curvidens* line.

The other species in *Agapetus* form a line also stemming from a primitive *Synagapetus* type, but a line which branched into several subsidiary developments. One of them culminated in the *membrosus* complex, another in the relatively primitive *comatus* complex, a third in the *fuscipes*



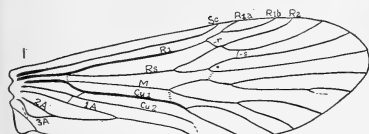

ANAGAPETUS DEBILIS

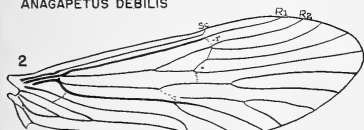

ELECTRAGAPETUS TSUDAI

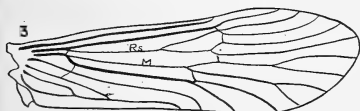

AGAPETUS ILLINI



AG. MEMBRUSUS

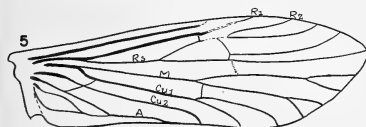

AG. CURVIDENS

FIGS. 1-5.—Front wings of the *Agapetus* line.

complex, these three apparently confined entirely to Eurasia, and a fourth which gave rise to the American species of *Agapetus*.

There are other lines that I am unable to place phylogenetically in satisfactory fashion but that probably originated as close relatives of the *comatus* group. These include the following, tentatively considered as subgenera of *Agapetus* until detailed study allows more exact treatment: *Myspoleo* Barnard, from South Africa; *Afragapetus* Mosely, from the mountains of east-central Africa; *Allagapetus* Martynov, from Turkestan and India; and *Lanagapetus* Mosely, from Madeira.

The American species exhibit two circumstances suggesting their position in relation to the Eurasian fauna. In the first place, although

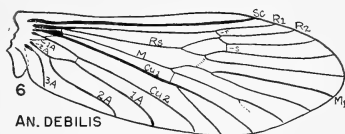

AN. DEBILIS

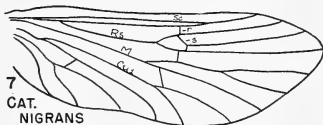

CAT. NIGRANS

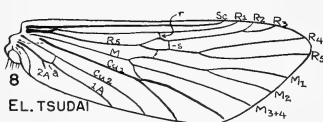

EL. TSUDAI

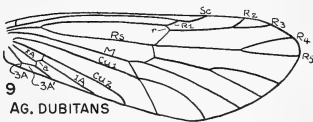

AG. DUBITANS

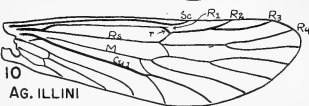

AG. ILLINI



AG. PINATUS

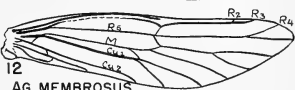

AG. MEMBRUSUS

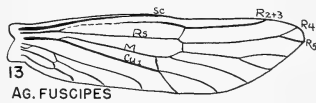

AG. FUSCIPES

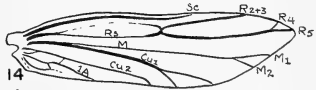

AG. CURVIDENS

FIGS. 6-14.—Hind wings of the *Agapetus* line: Ag., *Agapetus*; An., *Anagapetus*; Cat., *Catagapetus*; El., *Electragapetus*. (Fig. 7 after McLachlan; Fig. 9 after Mosely.)

the American fauna contains many diverse types of genitalia, they appear to be related to each other rather than to various known complexes of the Eurasian fauna. In the second place, the base of the various lines begins with forms having a relatively primitive hind wing venation (Fig. 10) little changed from the primitive *Synagapetus* wing (Fig. 9). This indicates that the American fauna probably arose from a single ancestor which crossed from Eurasia to North America, and that this ancestor was a primitive form of the *Agapetus* branch which developed the lateral male organ. None of the American species have undergone a great deal of evolution as regards venation. The primitive species such as *boulde-rensis* and *illini* have in the hind wing a faint trace of the base of  $R_1$  (Fig. 10) and definite angulations where  $r$  joins  $R_1$  and  $R_{2+3}$  and in the males a fairly long cell  $R_2$ . The most specialized wings differ only in that the serial radial vein has become smoother in the region of  $r$ , all trace of  $R_1$  beyond this point is lost, and cell  $R_2$  is short in both sexes (Fig. 11).

The relationships of the genera and the known lines of *Agapetus* are shown in Fig. 15. This chart shows the few specialized lines of *Agapetus* actually studied, and in addition an approximation of the origin of the African lines. While the nature of the lateral male organ is not known for the African species, the venation and male genitalia are relatively generalized and indicate that these arose from a form essentially like that persisting in the *comatus* line.

#### BIOGEOGRAPHY

With the exception of the Baltic amber *Electragapetus scitulus*, the data for biogeographical analysis of the group under discussion consist entirely of the known distribution patterns of existing species. These patterns are fragmentary for many species, but nonetheless they bring out certain points that should furnish at least a starting point for needed further study in this field.

Judged from the habitat or climatic preference of all existing species, the group is and always has been restricted to clear, cold, small streams or brooks. The only exception is the subgenus *Tagapetus*, which probably inhabits warmer streams than is typical for other species. This cold-adapted characteristic of the group means that all spreading of range occurred only through territory where such streams were relatively

numerous. For range extensions from Eurasia into Africa, a mountain highway would have been imperative in order to afford these stream conditions through the equatorial belt.

The ancestral genus *Anagapetus* is quite successful in many montane localities in North America in competition with both *Glossosoma* and *Agapetus*. From this it would seem probable that if it had ever occurred in Eurasia, some remnant of it would still survive and have been found. On the same grounds of competitive behavior, the genera *Catagapetus* and *Electragapetus* may be ascribed to an existence confined to Eurasia. Since this constitutes our only evidence, I am following it as a general precept.

#### DISPERSAL AND EVOLUTIONARY LINES

The *Catagapetus*-*Agapetus* line (Fig. 15) probably started in late Cretaceous or early Cenozoic time as a population of *Anagapetus* which spread

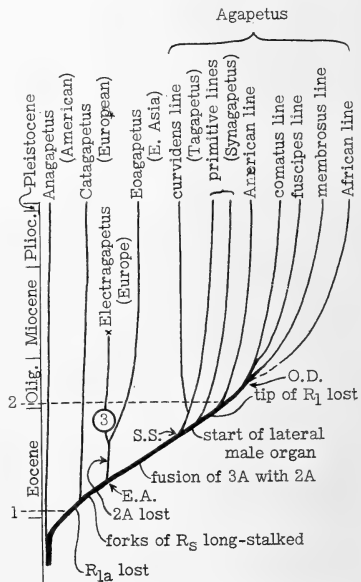

FIG. 15.—Diagram of phylogeny of the *Agapetus* line: E.A., *Electragapetus* ancestor; S.S., *Synagapetus* stage; A.A., *Agapetus* ancestor. 1, early Eocene dispersal; 2, early Oligocene dispersal; 3, approximate horizon of fossil *Electragapetus*.

from North America into Eurasia. This gave rise first to a *Catagapetus*-like form differing in only a few morphological respects from its progenitor. From this form arose a more modified form, in which the hind wing underwent reduction of venation and produced a form much like *Electragapetus*, but retaining all of vein 2A in the hind wing. This, the *Electragapetus* Ancestor, must have become widespread, divided, and had its parts isolated geographically, for it gave rise to two distinct phyletic lines, leading to *Electragapetus* and *Agapetus*, respectively.

The *Electragapetus* line remained very like its ancestor, changing only slightly in venation. It had developed into a definitive *Electragapetus* morphotype by late Eocene or early Oligocene, and it is a matter of record in the Baltic amber that it occurred at this time in the vicinity of Germany. Eventually its range embraced all Eurasia, as witnessed by living species in eastern Siberia and Japan.

The *Agapetus* line underwent continued reduction in hind wing venation, and reached the *Synagapetus* stage before a successful, long range, competitive form was evolved. This type also became widespread over Eurasia, with existing species having primitive types of genitalia surviving in China, India, and many areas in Europe, and more specialized species in Japan and Madeira. There is one record, based on a female specimen, from northern Ontario, Canada, which may indicate a spread of the group through northern North America, but pending knowledge of the male no interpretation of this record will be attempted.

This primitive *Synagapetus* group gave rise to a line that may have become isolated in the islands to the east of the Asiatic coast. Its only known members are now recorded only from Japan, the Philippine Islands, Java, and New Guinea. The line has undergone much change, culminating in the *curvidens* complex.

Other *Synagapetus* stock developed a curious lateral organ on the fifth sternite of the male. After this development there occurred a spread of the line throughout continental Eurasia and into North America and possibly also Africa. Each of these extensions of range is represented today by an isolated and frequently highly distinctive group. From this it seems certain that after the range extension occurred, most of the avenues of dispersal became ecologically unsuitable for *Agapetus* and have remained so since.

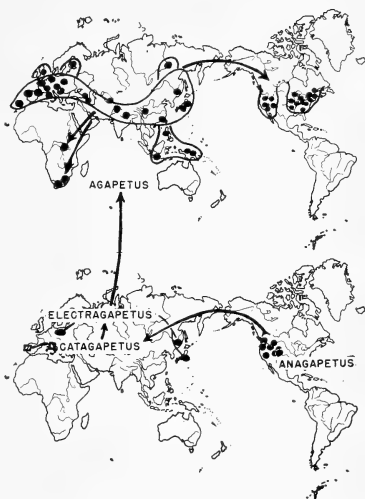

FIG. 16.—The dispersal cycle of the *Anagapetus* to *Agapetus* evolutionary line. In the upper map the present distribution pattern of the generalized species of *Agapetus* (chiefly *Synagapetus*) is diagrammed as the sinuate oval across Eurasia.

Otherwise we would expect a mingling of diverse faunal units in the periphery of the range of the group. It is likely that this radiation was made possible by the extensive orogenies culminating in the Miocene, which provided avenues of dispersal across the old sea Tethys and gave rise to the African mountains and many of the extensive ranges in southern Europe and Asia.

The retention of the stub of  $R_1$  in the hind wing of primitive American species indicates that this line resulted from a population which spread into North America before the European and African progenitors had evolved. The monophyletic nature of the existing American fauna indicates that no later dispersals occurred from Asia, and the Asiatic fauna indicates that no American forms spread back to Asia.

#### TIME RELATIONSHIPS

The problem of fixing the evolutionary sequence in Fig. 15 calls for a matching of known or inferred time of events based on information from the *Agapetus* data with possible dispersal opportunities deduced from studies of other

groups. In this latter connection I have drawn chiefly on the summary of Holarctic mammal dispersal given by Simpson (1947).

The Oligocene Baltic amber fossil *Electragapetus* provides us with one approach to the dating problem. Referring to Fig. 15, we see that—

1. There must have existed an ancestor common to both *Electragapetus* and *Agapetus*, which possessed a hind wing like Fig. 8 but which retained vein 2A, still preserved in *Agapetus*. This ancestor is indicated as E. A. in Fig. 15.

2. The *Electragapetus* line lost 2A. The time which elapsed during this loss represents the time interval between E. A. and the formation of the generic characteristics of *Electragapetus* as it appears in Oligocene amber and today. There is no evidence to indicate how far this occurred up the *Electragapetus* line, so in Fig. 15 this must first be placed arbitrarily as an indeterminate period. It is highly likely that the *Electragapetus* line continued as a viable, primitive line for some time after the separation of *Eoagapetus*. The assumed point of extinction of the *Electragapetus* line is terminated by an "x." This point is purely arbitrary.

3. In the fossil *Electragapetus* hind wing, vein 2A is atrophied to cross-vein *a*. In subgenus *Eoagapetus* there is still a vestige of this vein. On this evidence, the division between the two occurred before early Oligocene from which the fossil is known. This places the time of E. A. as definitely pre-Oligocene and further places the time of the spread of *Anagapetus* into Eurasia as considerably before Oligocene.

Another suggested dating occurs at point O. D. (Old World dispersal of *Agapetus*). Shortly after the spread of *Agapetus* to North America (morphologically speaking) there occurred a dispersal of *Agapetus* to the various mountainous regions of southern Eurasia and Africa. Since Africa is involved, this spread could hardly have occurred prior to the shrinkage of Tethys in the Miocene; it is also likely that suitable mountain habitats were not available in Africa and parts of southern Eurasia until the orogenies producing the shrinkage of Tethys had progressed to an advanced stage. It is also apparent that following the spread of a primitive *Agapetus* there was an isolation of populations in various areas, an isolation that has persisted to the present. During this period each isolate has developed into a distinctive taxonomic entity.

Turning to evidence that Simpson (1947) has assembled from distribution of mammalian fossils, there is found a remarkably close correlation with certain conclusions. Simpson postulates that (1) there was a relatively complete interchange of American and Eurasian forms in early Eocene, (2) a lesser but extensive interchange in early Oligocene, and (3) small interchanges of only limited ecological types until late Pliocene. Although Pliocene and Pleistocene interchanges were not made by *Agapetus*, the first two points fit very well with the analysis made of the genus.

Evidence from the phylogeny of the Rhyacophilidae (Ross, 1951) gives every reason to believe that *Anagapetus* had evolved by middle or late Cretaceous. It could have spread into Eurasia on an early Eocene bridge, and the Eurasian isolate start on the evolutionary road to *Agapetus*. If this time of crossing is correct, the Eurasian line evolved fairly rapidly through ancestral *Catagapetus* and *Electragapetus* stages and past the early *Agapetus* stage (that is, *Synagapetus*) before Oligocene. Presumably the specialized *Agapetus* line had just begun to evolve when a species of its early complex spread into North America and then was cut off on this continent. The slightly more specialized European continuation of the line spread in Miocene to its present outposts.

This explanation satisfies the conditions that E. A. be pre-Oligocene, and that O. D. be late Oligocene or Miocene. Beyond these limits, of course, the branchings in Fig. 15 are simply "reasonable estimates."

One question arising from this explanation is of more than usual interest. When *Agapetus* spread into North America, why did not *Catagapetus* and/or *Electragapetus* spread with it? They were both extant somewhere in Eurasia at that time. It is quite possible that they may yet be found in North America, for many mountain regions of the Northwest are virtually uncollected; or they may have made an entry and the colony become extinct. It is also possible that these two genera were confined to Europe or Western Asia during early Oligocene. A third and highly plausible alternative is that *Agapetus* had developed an ecological tolerance for warmer streams than the other two, and that in the Oligocene conditions on the Bering bridge were opportune for *Agapetus* but not for the others.

## TAXONOMIC NOTES

Certain of the deductions made in the preceding pages are based on new species, which are described below. Unless otherwise stated, types are in the collection of the Illinois Natural History Survey.

Genus **Electragapetus** Ulmer

This genus was described to include a single fossil species, *scitulus* Ulmer, from Baltic amber. Later Martynov described the genus *Eoagapetus* to receive a living species, *praeteritus* Martynov, from eastern Siberia. The venation of the two is virtually identical, the differences between the two groups being mainly in male genitalia. This relationship seems best expressed by considering the two groups as subgenera, as follows:

*Cercus* digitate, projecting free from narrow base, similar to condition shown in Fig. 21A

**Electragapetus**

*Cercus* low, with basal attached portion very long, apical edge with a row of fine setae, Fig. 17A

**Eoagapetus**Subgenus **Eoagapetus** Martynov

## KEY TO SPECIES

- Lobes of tenth tergite symmetrical, each with a short lateral point at tip; cercus evenly crescent shaped; clasper with apical margin notched to produce a wide dorsal and very narrow ventral lobe. . . . . **praeteritus** Martynov
- Lobes of tenth tergite asymmetrical, right lobe inconspicuous and membranous, left lobe sclerotized and with its ventral angle produced into a long slender finger; cercus with ventral portion larger than dorsal; clasper simple, Fig. 17. . . . . **tsudai**, n. sp.

**Electragapetus tsudai**, n. sp.

Many characters of the genitalia differentiate this species from *praeteritus*, summarized in the preceding couplet.

*Male*.—Length 8 mm. Color dark brown, legs and venter slightly lighter than dorsal portion. General structure, including wing venation, Figs. 2 and 8, typical for genus. Fifth abdominal sternite with only slightly embossed lateral areas. Genitalia as in Fig. 17. Tenth tergite with right lobe membranous and inconspicuous, left lobe with ventral corner digitate and long, angled both ventrad and laterad. Cercus forming a short but very deep flap, extending ventrad over the base of the clasper. Clasper with lateral aspect regular, rounded at apex, and nearly twice as

long as deep; both upper and lower margins have a sclerotized tooth a third distance from apex. Aedeagus very long, with a pair of long sclerotized rods, one flattened and convoluted before the spinelike apex, the other slender, more rounded, and nearly straight.

*Holotype*.—Male; Higashiyama, Fukushima Pref., Japan, May 24, 1949, Mrs. M. Kohno.

*Paratype*.—Yu River, Higashiyama, Kita-aizugun, Fukushima Pref., May 24, 1949, Mrs. M. Kohno.

Genus **Agapetus** Leach

Arriving at a workable classification for this genus has been difficult. While the species resolve into separate phyletic lines, the primitive members of a line sometimes differ little from members of unspecialized lines, but the end species of the line may be radically different from any other species in the genus. It is desirable to make special subgeneric categories for the very unusual forms, yet it seems impractical to make a separate subgenus for every phyletic line.

Subgenus **Synagapetus** McLachlan

To this subgenus authors have usually referred species in which hind wing  $R_1$  joins Sc, Fig. 9, and the female middle tibiae are dilated. It is now apparent that this simple definition is in need of revision, but a more thorough understanding of the genus is required to reach a satisfactory result. For purposes of the present I am considering *Synagapetus* as a broad unit, including species previously placed in *Synagapetus* and *Pseudagapetus*, and a third group having hind wing  $R_1$  lost at its tip but with no male lateral organ. This latter group includes *japonicus* Tsuda, and three New Guinea species described here. At the evolutionary apex of the line stand the Philippine species *curvidens* Ulmer (Fig. 14) and the Java species *abbreviatus* Ulmer. These two are so distinct from other members of their line that they have evidently come under the influence of new, strong selection pressures and started a divergent branch of their own. A new subgenus is therefore erected for their reception.

**Agapetus ulmeri**, n. sp.

The very simple male genitalia and venation indicate this as one of the primitive members of the genus. The angulate anterior margin of the ninth segment, however, in this and the two

following species indicates that they are offshoots from the base of the *curvidens* line. The short, truncate tenth tergite lobes combined with the slender clasper differentiate this species from its relatives.

*Male*.—Length 3.5 mm. Color dark brown, the legs and venter slightly lighter. General structure typical for genus, venation similar to that of *illini* female, but the hind wing with no vestige of the tip of  $R_1$  and with no pronounced dip in the  $R_1$  serial vein at  $r$ . Front tibia with inner apical spur much shorter than outer, both fairly small. Fifth abdominal sternite with simple embossed area. Genitalia as in Fig. 19. Ninth segment with anterior margin broadly but fairly sharply angulate. Lobes of tenth tergite deep and short, truncate at apex, and each with a dorso-lateral flange above cercus. Cercus finger-like, with four long setae. Clasper simple, the apical portion narrowed, straight, and without sclerotized points. Aedeagus with simple rods sharply upcurved at apex.

*Holotype*.—Male; Hollandia, New Guinea, rain forest, March 22, 1945, H. Hoogstraal.

#### *Agapetus jafiwi*, n. sp.

This species is most closely related to the preceding, from which it differs in the shape of the tenth tergite lobes and the produced anterior margin of the ninth segment.

*Male*.—Length 4 mm. Color and general structure, including wing venation and fifth abdominal segment, as in the preceding species. Genitalia as in Fig. 20. Ninth segment fairly long both dorsad and ventrad, its anterior margin produced into a long internal projection with a pointed apex. Tenth tergite with each lobe fairly long and deep, with a recurved, small, dorsal hook and the extreme apex also forming a hook-like projection. Cercus short and stout, with four long setae. Clasper long, with base only moderately wide, apex pointed, and with a pointed ventromesal flap just before the apex.

*Holotype*.—Male; Hollandia, New Guinea, March 15, 1945, at light, near Jafiwi, H. Hoogstraal.

#### *Agapetus latosus*, n. sp.

The tenth tergite lobes in this species have a most curious shelflike lateral overhang which is unlike anything else illustrated in the genus. Other characters, especially the produced ninth

segment and simple clasper, indicate that this is another member of the *curvidens* line.

*Male*.—Length 3.5 mm. Color, general structure, venation, and characters of the fifth abdominal sternites as for the preceding species. Genitalia as in Fig. 22. Ninth segment narrow dorsad, longer than usual ventrad, the anterior margin produced into a large, trianguloid, rounded projection. Tenth tergite lobes deep at base, with a lateral, irregularly serrate overhang; the apex of each lobe forms a triangular, slightly downcurved piece the base of which fits under the lateral overhang. Cercus elongate and slender, with four setae on apical third, its dorsal aspect appearing a little bulbous at base. Clasper with lateral aspect short, parallel sided and rounded at apex; ventral aspect with a mesal point at apex, and with basal half wide. Aedeagus with simple rods.

*Holotype*.—Male; Doromena, Netherlands New Guinea, February 25, 1945, Hoogstraal and Jewett.

*Paratypes*.—Same data, 2 ♂.

#### *Tagapetus*, n. subg.

*Characteristics*.—General structure of head and body typical for genus. Diagnostic differences in venation are as follows: front wing (Fig. 5) with fork  $R_{4+5}$  very narrow, and cross-vein  $s$  long, so that vein  $R_4$  is much closer to  $R_5$  than to  $R_3$ , and with both forks of  $M$  close to margin of wing; hind wing (Fig. 14) with  $Sc$  distinct from margin, the two principal radial veins very close together at center of wing, and vein  $M_{3+4}$  and cross-vein  $m-cu$  entirely atrophied; in addition the hind wing has  $R_{2+3}$  unbranched,  $R_{4+5}$  with a very short branch, and apex of  $2A$  reduced to an indistinct stub.

*Genotype*.—*Agapetus curvidens* Ulmer.

In addition to the genotype, *Tagapetus* includes *abbreviatus* Ulmer from Java.

The male genitalia of the genotype (Fig. 21) exhibit many characteristics of the generalized type, with the addition of the slender, elongate and sinuate clasper and the anterior sharp projection of the ninth segment. These characters of genitalia leave no doubt but that *curvidens* is one of the end products of its phyletic line. The unusually great differences in wing venation also indicate clearly that the two species in the subgenus have undergone very rapid evolution compared to all other members of their line.

Subgenus *Agapetus* Leach

*Agapetus membrus*, n. sp.

The subgenus *Agapetus* is defined here as the general group in which the tip of  $R_1$  is atrophied in the hind wing, and the lateral abdominal organ of the male is well developed as a round or ovoid internal structure.

This species is one of the end branches of the *membrus* line, differing from the *bidens* group in having the apex of both the clasper and membranous dorsal lobe blunt rather than sharp and pointed. In addition the ventral spur of the

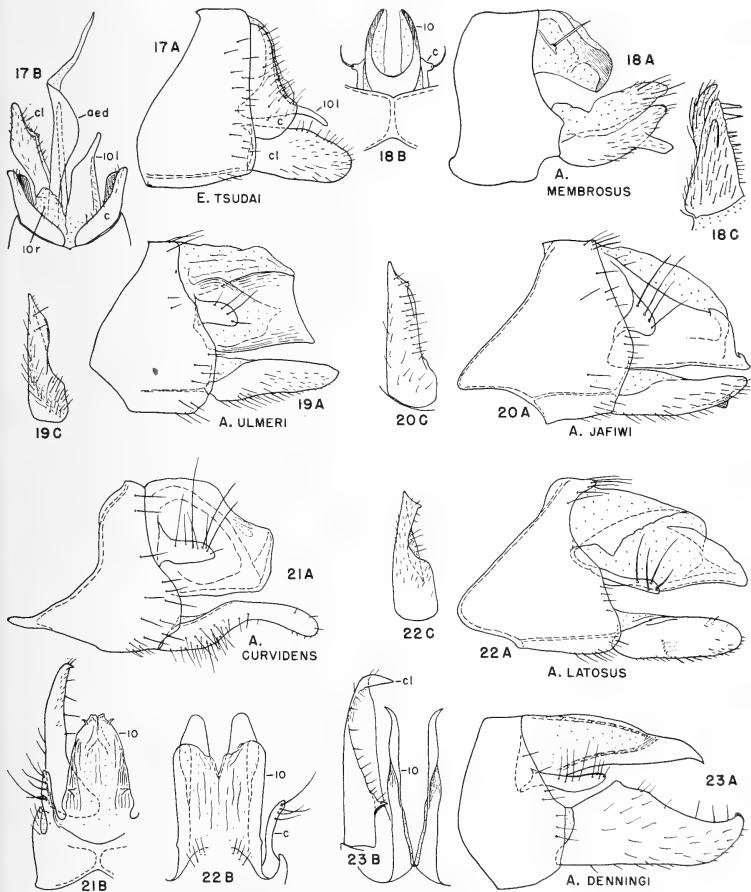

FIGS. 17-23.—Male genitalia of *Electragapetus* (*E.*) and *Agapetus* (*A.*): A, Lateral aspect; B, dorsal aspect; C, ventral aspect of clasper. (*aed*, aedeagus; *c*, cercus; *cl*, clasper; *l*, left lobe; *r*, right lobe.)

clasper is short in *membrosus*, long and pointed in the *bidens* group.

*Male*.—Length 3 mm. Color dark brown, nearly black, the venter and legs slightly lighter. General structure typical for genus. Hind wing, Fig. 12, with Sc close to but slightly separated from margin;  $R_{2+3}$  with minute branch at extreme apex; anal veins with base of 2A and apex of 1A forming a straight serial vein, beneath which is a single loop of doubtful composition (see discussion above for *membrosus* group). Fifth sternite with lateral areas embossed. Genitalia as in Fig. 18. Tenth tergite divided into a pair of stout, curved arms. Cercus represented by a thin strap embedded in membrane, the end of the strap with a single long seta. Clasper with a short, triangular main piece with a dorsal membranous lobe and a ventral truncate projection. Aedeagus with simple rods.

*Female*.—Length 3.5 mm. Color and general structure as in male. Middle legs with tibia and basitarsus expanded, foliaceous, and concave mesad. Abdomen slender and pointed.

*Holotype*.—Male; Unlong-kong (above), Szechwan, China, 12,000–15,000 feet elevation, July 3, 1929, H. Stevens.

*Allotype*.—Female; Tu-pa-keo, Szechwan, China, 7,400 feet elevation, September 3, 1929, H. Stevens.

*Paratypes*.—All from Szechwan, China, H. Stevens: same data as for holotype, 2♂; same data as for allotype, 1♀; same as for allotype, but September 5, 2♂; between Shuang-yo and Tu-pa-keo, August 30, 1929, 1♂. Holotype, allotype, and three paratypes in the Chicago Natural History Museum; three paratypes in the collection of the Illinois Natural History Survey.

#### *Agapetus denningi*, n. sp.

The genitalia indicate that this species belongs to the small complex including *ophionis* Ross and *taho* Ross and is an especially close relative of *taho*. From this species, *denningi* differs in having a more triangular lateral aspect of the clasper and an almost even dorsal outline of the tenth tergite, which ends in a simple, downcurved point. It is likely that *denningi* represents a condition close to that of the ancestor of the complex.

*Male*.—Length 5 mm. Color dark brown, slightly lighter on legs and venter. General structure typical for genus, and for subgenus as described above. Genitalia as in Fig. 23. Ninth segment nearly annular, with anterior margin evenly bowed. Tenth tergite with lobes blade-like and thin, each with lateral aspect fairly shallow, triangular, elongate, and ending in a sclerotized portion which is curved ventrad and beaklike. Cercus moderately long and slender, with an irregular row of long setae. Clasper with base massive, apex tapering to a point curved sharply mesad; at the dorsal apex of the basal portion is a short, sharp projection pointed mesad. Aedeagus with simple rods.

*Female*.—Size, color, and general structure as for male. Female characters typical for *ophionis* complex, for which means of specific separation in this sex are not yet known.

*Types*.—Holotype, male, Rouge River National Forest, Oreg. Allotype, female, and paratype, male, same data. Holotype and allotype in the collection of D. G. Denning, paratype in the collection of the Illinois Natural History Survey.

#### ACKNOWLEDGMENTS

I wish to express my gratitude to Dr. E. W. King for a great deal of assistance with this study, especially for making the illustrations of the wings. To Mrs. M. Kohno, Dr. Tsuda, Dr. C. O. Mohr, Harry Hoogstraal, Dr. C. H. Remington, and Dr. E. S. Ross I am indebted for the opportunity to study much Oriental material. Two other items have been an invaluable aid in this study—Dr. Ulmer's fine work on the Oriental fauna and Mr. Kimmins's excellent illustrations made for papers of the late Martin E. Mosely.

#### LITERATURE CITED

- EMERSON, ALFRED E. *Five new genera of termites from South America and Madagascar*. Amer. Mus. Nov. no. 1444: 1–15, 6 figs. 1950.
- ROSS, HERBERT H. *The origin and dispersal of a group of primitive caddisflies*. Evolution 5: 102–115. 1951.
- SIMPSON, GEORGE G. *Holarctic mammalian faunas and continental relationships during the Cenozoic*. Bull. Geol. Soc. Amer. 58: 613–688, 6 figs. 1947.



HERPETOLOGY.—*Studies on the lizard family Xantusiidae, II: Geographical variation in Xantusia riversiana from the Channel Islands of California.* JAY M. SAVAGE, Natural History Museum, Stanford University. (Communicated by F. J. Hermann.)

While studying the Baja California night lizards of the species *Xantusia vigilis* (Savage, 1951), I examined the two supposed subspecies of the island night lizard, *Xantusia riversiana*, in an attempt to determine what characters might be of value in delimiting subspecies within the genus. Preliminary inspection revealed that the characters used to differentiate the two nominal subspecies of *riversiana* were apparently so subject to individual variation and personal interpretation that doubt was cast upon the value of sub-dividing the species.

*Xantusia riversiana* was described by Cope (1883, p. 29) as the second known species of the genus. Since that time the species has been found to be endemic to San Nicolas, Santa Barbara, and San Clemente Islands in the southern group of Channel Islands off the coast of southern California. The restricted range and structural homogeneity of the island night lizards has caused most authors to regard all three insular colonies as forming a single population. Dr. Hobart M. Smith (1946, p. 292) was the first seriously to question this concept. He proposed that the San Clemente Island colony should be recognized as a distinct subspecies, *X. riversiana reticulata*. His conclusions were derived from an examination of one specimen from San Clemente Island and three examples from San Nicolas Island, the type locality of *X. r. riversiana*.

Smith would differentiate the two nominal subspecies on the basis of the following characteristics: *riversiana*—(1) preanal scales large, regular; (2) central gular scales somewhat enlarged; (3) pregular fold well defined; (4) sutures between head scales clearly apparent, although some pits present; (5) a distinct dorsolateral light streak on each side; (6) dorsal pattern less distinctly marked with dark; *reticulata*—(1) preanal scales small, irregular; (2) central gular scales nearly uniform, scarcely enlarged medially; (3) pregular fold poorly defined; (4) head plates exceedingly pitted, corrugated and

broken up; (5) no dorsolateral light line; (6) dorsal pattern reticulated and spotted with black.

#### ANALYSIS OF CHARACTERISTICS

The taxonomic value of several of these characteristics (size of gulars, nature of pregular fold, and coloration) might immediately be questioned by anyone familiar with variation in xantusiid lizards. Others of the supposed diagnostic characters would at first glance seem to be useful in the definition of subspecies in this family (size and number of preanals and nature of head scalation). In order to discover the normal range of variation and determine those differences of systematic significance, an analysis of each of Smith's criteria was undertaken in a relatively large sample of island night lizards. Comparison and study of 24 specimens from San Nicolas Island, 11 from Santa Barbara Island, and 61 from San Clemente Island have supplied the information presented below and represent, I believe, an adequate summary of the variation of these characteristics.

*Prenals*.—The preanal scales are basically six in number, large and arranged in three transverse rows. Considerable breaking up of these scales occurs in some individuals, and the condition may vary from the regular 6-scaled type through innumerable intermediates until as many as 18 small, irregular scales are present. The majority of specimens in this sample had seven to nine preanal scales. Fisher (1936, p. 175) illustrates a similar variability in a large sample of the mainland species, *X. vigilis vigilis*.

Obviously, when applying Smith's terms "large, regular" and "small, irregular" to this character, it was necessary to set rather arbitrary limits as to what constituted these two categories. When the preanals were maintained in a condition approaching a regular series of large, unbroken scales they have been recorded as "large." Those lizards with the preanal scales fragmented into a large number of small, irregularly shaped scales have been included under "small." Utilizing these definitions the nature of the preanal scales and the percentage composition of each type in the three insular populations is given in Table 1.

TABLE 1.—VARIATION IN PREANAL SCALES

	San Nicolas		Santa Barbara		San Clemente		Totals	
	Number	Percent	Number	Percent	Number	Percent	Number	Percent
Large, regular.....	8	33	1	9	20	33	29	30
Small, irregular.....	16	67	10	91	41	67	67	70
Totals.....	24	100	11	100	61	100	96	100

An examination of Table 1 shows that the presence of "large" preanal scales is consistently low in all three island populations. San Clemente and San Nicolas Island specimens are almost identical in the percentage composition of large and small preanals and cannot be separated on the basis of this character. No significant difference exists between these two samples and the series from Santa Barbara Island. The apparent discrepancy in the percentage composition between this latter group of lizards and those from the other two islands is probably attributable to the small size of the Santa Barbara sample.

Actually the splitting up of the preanal scales is probably not the result of any genetic factor but of a developmental change produced by some environmental influence during early ontogeny. Similar environmental effects have been shown to influence scutellation in snakes (Fox, 1948, p. 252) and in turtles (Lynn and Ullrich, 1950, p. 253). If environmental factors are responsible, the slight differences observed between Santa Barbara Island lizards and the series from other islands could not be considered of systematic value as a significant difference would only be a reflection of ecological effects upon the development of the sample. Obviously the nature of the preanal scales in island night lizards is of no taxonomic value and cannot be accepted as a criterion for distinguishing subspecies.

*Gular scales.*—The difference in the relative size of the median gular scales, as used by Smith, is of such a fine qualitative distinction as to be almost impossible to apply. As pointed out by Fisher (1936, p. 174) in the related night lizard, *X. v. vigilis*, the number of enlarged scales on the gular fold is subject to wide variation. In *X. riversiana* the size of the gulars as well as the number is quite variable. It is true that some individuals appear to have the two median gular scales somewhat larger than their fellows but just where to draw the line between gulars

"scarcely enlarged medially" and gulars that are "somewhat enlarged" presents a problem. It was necessary for tabulation that some sort of decision as to what constitutes these two categories be made. I have therefore included under the "enlarged" group only those examples having the central gular scales very definitely larger than those adjacent to them. Frankly, I do not feel that even this method is valid in determining the size of the gulars, and independent examination of several series at different times confirms this suspicion. A sample of specimens from each island was examined by me on four different occasions. Upon each one of these occasions a different number of "enlarged" examples was recognized. To make matters worse, examples classified as "large" on one occasion would be grouped with "scarcely enlarged" the next time the samples were examined. Apparently the character is so variable that a clear-cut decision cannot be made as to which group, "enlarged" or "scarcely enlarged," any given individual belongs.

The results of the analysis of this characteristic, utilizing the methods of determination explained above, are presented in Table 2. San Clemente lizards are almost constant in having the median scales enlarged. The small Santa Barbara series has more enlarged than uniform examples and the San Nicolas specimens are almost evenly divided between the two types. It might be argued that the San Clemente Island population could be separated from the other two colonies on the basis of this character. However, at least 50 percent of the San Nicolas and Santa Barbara specimens would fall into the same category as San Clemente examples. The high percentage of "enlarged" gulars listed for the San Clemente sample may actually be the result of bias on my part. These specimens were the first lizards examined in the study when I was not too adept at distinguishing between the two supposed types of gulars. Consequently it is probable that a re-

TABLE 2.—VARIATION IN SIZE OF GULAR SCALES

	San Nicolas		Santa Barbara		San Clemente		Totals	
	Number	Percent	Number	Percent	Number	Percent	Number	Percent
Enlarged.....	14	58	9	82	60	98	83	86
Uniform.....	10	42	2	18	1	2	13	14
Totals.....	24	100	11	100	61	100	96	100

examination of the San Clemente series would result in slightly different groupings. These facts coupled with the difficulties already emphasized in determining the nature of the gular scale character forces the rejection of this characteristic as a systematic aid.

*Pregular fold.*—All *Xantusia* possess two more or less well-developed preular folds. The posterior fold is usually well marked and lies only a few scales anterior to the gular fold. The anterior preular fold extends from the base of the auricular aperture on one side across the throat to the opposite ear opening and is usually poorly developed or absent in the live animal. It is this latter fold which is used by Smith to characterize his two subspecies of *X. riversiana*. Unfortunately, Smith did not have enough material to ascertain that the anterior preular fold is often absent in living material and usually appears only as the result of preservation. In my experience, the anterior preular fold is often distorted and frequently not visible even subsequent to preservation. Consequently, the separation of two populations on the basis of the presence or absence of this fold seems impossible.

Table 3 represents the presence or absence of the anterior preular fold in a series of unevenly preserved specimens. The table is nothing but an account of the manner in which these lizards were preserved and is included to make it obvious that even if this character were not due to the mode of preservation no really significant differences occur between the various colonies. The San Nicolas sample is somewhat isolated in the relative proportions of the two types of fold but this is probably the result of the fact that the majority of the San Nicolas examples are from a single collection and were all preserved in a similar manner. The preular difference is thus of absolutely no significance in *X. riversiana*.

*Pitting of the head shields.*—Table 4 shows that the number of individuals from each sample with the head shields so pitted as to completely obscure the sutures between the shields is relatively small. The character appears to be correlated with the age of the specimen, for the head shields are broken up in all large examples regardless of locality and the smaller specimens lack excessive pittings. The pits are present on all lizards examined although difficult to find on a number of small examples. They appear to be the openings of integumentary "glands" similar in some respects to the femoral pores. Apparently these

TABLE 3.—VARIATION IN PREGULAR FOLD

	San Nicolas		Santa Barbara		San Clemente		Totals	
	Number	Percent	Number	Percent	Number	Percent	Number	Percent
Well defined . . . . .	9	37	7	64	47	77	63	66
Poorly defined . . . . .	15	63	4	36	14	23	33	34
Totals . . . . .	24	100	11	100	61	100	96	100

TABLE 4.—VARIATION IN STRUCTURE OF HEAD SHIELDS

	San Nicolas		Santa Barbara		San Clemente		Totals	
	Number	Percent	Number	Percent	Number	Percent	Number	Percent
Broken up . . . . .	0	0	2	18	6	10	8	8
Smooth . . . . .	24	100	9	82	55	90	88	92
Totals . . . . .	24	100	11	100	61	100	96	100

pits grow at a constant rate throughout life and, after the general growth rate of the lizard begins to slow down at maturity, the pits continue to expand and eventually succeed in completely deforming the usual configuration of the head shields. No geographic correlation of a sufficient magnitude to warrant a separation of one insular colony from another is indicated by the distribution of this character. San Nicolas Island examples lack broken up head shields but this is probably the fault of the sample which consists almost entirely of moderate-sized lizards. This character must also be rejected as a means of delimiting subpopulations of *X. riversiana*.

*Dorsal coloration.*—The dorsal pattern of these lizards is usually a gray, brownish or cream ground-color upon which is superimposed a series of reticulated longitudinal bands. These bands vary in color from light brown to black and are sometimes coalesced to form two rigidly delimited dorsolateral dark stripes and a single well-defined dorsal band. The ground color between these stripes or bands appears as two light spaces. In extreme specimens possessing these dorsolateral light stripes the upper margins of the dark dorsolateral stripes and lower margins of the middorsal stripe are heavily pigmented so that the light interspace is sharply defined. This is the condition assumed by Smith to be typical of San Nicolas Island night lizards. All sorts of

intermediates between the reticulate pattern and the lined phase occur within any single population. All young examples tend to be more or less striped in appearance but the most prominently striped specimens are mature individuals.

Taking the lizards with light lines well defined and bordered by a dark stripe as being "lined" and all other lizards as being "unlined," I prepared Table 5. The complete absence of striped individuals in the Santa Barbara series is most likely due to the small sample size. San Nicolas Island and San Clemente Island colonies are close in relative percentage composition of the two color phases. The character is obviously worthless as a means of separating the various island populations. It may be that the extreme lined phase is the product of a single recessive allele although the observed frequencies of lined forms are somewhat lower than might be expected on the basis of such a hypothesis.

It is notable that Dr. George S. Myers, of Stanford University, reports that he took both lined and unlined phases side by side under the same debris on San Clemente Island. Kenneth S. Norris, of the Scripps Institution of Oceanography, informs me of the same condition occurring on San Nicolas Island.

*Other characters.*—An analysis of scale counts and measurements reveals no significant differences between the three insular populations. Data on these counts and a complete redescription of the island night lizard are reserved for a projected monograph of the Xantusiidae.

TABLE 5.—VARIATION IN OCCURRENCE OF DORSOLATERAL LIGHT LINES

	San Nicolas		Santa Barbara		San Clemente		Totals	
	Number	Percent	Number	Percent	Number	Percent	Number	Percent
Lined.....	5	21	0	0	6	10	11	11
No lines.....	19	79	11	100	55	90	85	89
Totals.....	24	100	11	100	61	100	96	100

#### CONCLUSIONS

None of the characteristics employed by Smith to define his subspecies of *X. riversiana* are of value in separating the various island colonies. One character (preanals) is perhaps the result of environmental effects, another (gular scales) is a matter of individual interpretation, a third (pregular fold)

reflects the mode of preservation, a fourth (pitting of the head shields) is probably ontogenetic in nature, and the last (dorsal coloration) appears to be due to normal genetic variation. Since none of these characteristics can be utilized in defining subpopulations of the island night lizard, it follows that the name *X. riversiana reticulata* must be relegated to the synonymy of *X. riversiana*. This action is taken in the hope that it will avert further use of the name in the literature (Schwenkmeyer, 1949; Shaw, 1949; Knowlton, 1949) and prevent the recognition of a systematically nonexistent entity.

#### ACKNOWLEDGMENTS

For the loan of material that aided in this study I wish to thank Dr. Raymond B. Cowles, University of California, Los Angeles; Kenneth S. Norris, Scripps Institution of Oceanography; and Dr. Robert C. Stebbins, Museum of Vertebrate Zoology.

Sincere appreciation is expressed to Dr. George S. Myers, of Stanford University, who read the manuscript and added many helpful suggestions.

#### LITERATURE CITED

- COPE, EDWARD DRINKER. *Notes on the geographical distribution of Batrachia and Reptilia in western North America*. Proc. Acad. Nat. Sci. Philadelphia 1883: 10-35.
- FISHER, EDNA MARIE. *Some observations on Xantusia vigilis Baird*. Copeia, 1936 (3): 173-176, figs. 1-2. 1936.
- FOX, WADE. *Effect of temperature on development of scutellation in the garter snake, Thamnophis elegans atratus*. Copeia, 1948 (4): 252-262. 1948.
- KNOWLTON, GEORGE FRANKLIN. *Food of the island night lizard*. Herpetologica 5 (2): 45-46. 1949.
- LYNN, WILLIAM GARDNER, and ULRICH, MARY CORALIE. *Experimental production of shell abnormalities in turtles*. Copeia, 1950 (4): 253-262, figs. 1-2, pl. 1. 1950.
- SAVAGE, JAY MATHERS. *Studies on the lizard family Xantusiidae, I: The systematic status of the Baja California night lizards allied to Xantusia vigilis, with the description of a new subspecies*. Amer. Midl. Nat. (in press).
- SCHWENKMEYER, RICHARD CARL. *Food habits of the island night lizard, Xantusia riversiana reticulata, from San Clemente Island*. Nat. Hist. Misc. Chicago Acad. Sci. 38: 1-3. 1949.
- SHAW, CHARLES EDWARD. *Notes on broods of two xantusiids*. Herpetologica 5 (2): 23-26. 1949.
- SMITH, HOBART MUIR. *A subspecies of the lizard Xantusia riversiana*. Journ. Washington Acad. Sci. 36 (11): 292-293. 1946.

MAMMALOGY.—*Six new mammals from the state of San Luis Potosí, Mexico.*

WALTER W. DALQUEST, Louisiana State University Museum of Zoology, Baton Rouge, La. (Communicated by Herbert Friedmann.)

Among the many specimens acquired in the course of recent distributional studies of mammals conducted by Louisiana State University in the Mexican state of San Luis Potosí, there is material that represents a new species and five undescribed subspecies. These new forms are described here in advance of a more extensive account dealing with the mammals of San Luis Potosí as a whole. I am indebted to Hartley H. T. Jackson and Stanley P. Young, of the United States Fish and Wildlife Service, and to David H. Johnson and Henry W. Setzer, of the United States National Museum, for the loan of comparative material. Localities mentioned in the following accounts, unless otherwise specified, are in the state of San Luis Potosí; measurements are in millimeters; and capitalized color terms are from Ridgway (Color Standards and Color Nomenclature, Washington, D. C., 1912).

***Thomomys umbrinus newmani*, n. subsp.**

*Type*.—Adult female, skin and skull no. 4193, Louisiana State University Museum of Zoology; obtained 7 km northwest of Palma (village 12 km northwest of Salinas), San Luis Potosí, México, by Walter W. Dalquest on August 8, 1950; original number, 14537.

*Range*.—Known only from the desert plains near the city of Salinas in western San Luis Potosí.

*Description*.—A very small pocket gopher, total length 200 mm or less; condylobasal length less than 35 mm; males larger than females; skull small, smooth, relatively narrow; color pale, soft, near Sayal Brown above with the middorsal area scarcely darker, near Cinnamon-Brown; underparts pale gray to Light Pinkish Cinnamon.

*Comparisons*.—*Thomomys umbrinus newmani* is one of the smallest races of the species. It is distinctly smaller than *T. u. atrodorsalis* Nelson and Goldman from the mountains southeast of the city of San Luis Potosí, *T. u. zacatecae* Nelson and Goldman from southeastern Zacatecas, *T. u. supernus* Nelson and Goldman from central Guanajuato, or *T. u. enixus* Nelson and Goldman from the Sierra Moroni of southern

Zacatecas. *T. u. potosinus* Nelson and Goldman is similar to *newmani* in size but is much darker in color. All the above-mentioned races are darker than *newmani* except the large *T. u. zacatecae*, which, though richer in color, resembles *newmani* in lacking the distinct black or blackish wash in the middorsal area.

*Measurements*.—The arithmetic means for two adult male and three adult female topotypes are, respectively: Total length, 192, 185; length of tail, 61, 60; length of hind foot, 26, 26; height of ear from notch, 5, 5; condylobasal length (from occipital condyles to anteriormost edge of incisors), 33.6, 33.3; length of diastema, 12.4, 11.7; length of maxillary tooth row, 7.1, 6.9; zygomatic breadth, 21.6, 21.8; interorbital breadth, 6.4, 6.4; mastoid breadth, 18.3, 17.6; greatest crown breadth across upper molar rows, 6.9, 6.8.

*Remarks*.—This subspecies is named for Robert J. Newman, who obtained numerous specimens of mammals in the state of San Luis Potosí and who helped to obtain the specimens here listed.

*Specimens examined*.—Total number, 6, from: 7 km northwest of Palma, 5; Cerro Peñón Blanco, 1.

***Thomomys umbrinus arriagensis*, n. subsp.**

*Type*.—Adult male, skin and skull no. 5075, Louisiana State University Museum of Zoology; obtained 1 km south of Arriaga, San Luis Potosí, México, by Walter W. Dalquest on September 22, 1950; original number, 14780.

*Range*.—Known only from the type locality on the Plan de Arriaga, a small, high, arid plain near the Guanajuato boundary southwest of the city of San Luis Potosí.

*Description*.—A medium-sized pocket gopher but one of the largest of the central-Mexican races of *Thomomys umbrinus*; condylobasal length of adults more than 41 mm; skull large with flaring zygomatic arches; colors dull and ashy; middorsal area usually heavily washed with blackish; sides Sayal Brown to Cinnamon; underparts Drab.

*Comparisons*.—None of the subspecies of *Thomomys umbrinus* whose geographic ranges approach that of *T. u. arriagensis* is as large as *arriagensis*, has such flaring zygomatic arches, or

is as dull and ashy in color. The nearest races, geographically, are *neumani* and *potosinus*, two of the smallest races of the species. The larger forms, *atrodorsalis*, *zacatecae*, *enizus*, and *super-nus*, are all much smaller than *arriagensis*. Specimens of *T. u. crassidens* Nelson and Goldman from western Zacatecas have not been examined, but judged from the original description this race is much brighter in color than *arriagensis* though it may approach it in size.

*Measurements.*—The arithmetic means for four male and six female topotypes are, respectively: Total length, 219, 202; length of tail, 65, 62; length of hind foot, 28, 27; height of ear from notch, 6, 6; condylobasal length, 41.3, 37.9; length of diastema, 15.8, 14.1; length of maxillary tooth row, 8.0, 7.7; zygomatic breadth, 26.2, 24.5; interorbital breadth, 6.7, 6.6; mastoid breadth, 20.2, 19.6; greatest crown breadth across upper molar rows, 7.7, 7.6.

*Specimens examined.*—Total number, 10, all from the type locality.

***Perognathus penicillatus atrodorsalis*,  
n. subsp.**

*Type.*—Adult male, skin and skull no. 5226, Louisiana State University Museum of Zoology; obtained 7 km west of Presa de Guadalupe, San Luis Potosí, México, by Walter W. Dalquest on October 12, 1950; original number, 15109.

*Range.*—Desert plains of the central part of the state of San Luis Potosí from the western base of the Sierra Madre Oriental westward at least to the type locality. A related subspecies, *P. p. eremicus*, is found in northern San Luis Potosí, north and west of the city of Matehuala.

*Description.*—A medium-sized, slim-bodied pocket mouse with crested tail longer than head and body; lacking long, stiff spines in pelage of rump area; color of upperparts near Avellaneous mixed with black, with middorsal area, and sometimes the entire dorsal area, heavily washed with black or blackish.

*Comparison.*—The only subspecies of *Perognathus penicillatus* whose geographic range approaches that of *atrodorsalis* is *P. p. eremicus* Mearns. The heavy black wash on the back of *atrodorsalis*, present in all but a very few individuals, is sufficient to distinguish *atrodorsalis* from *eremicus*.

*Measurements.*—The arithmetic means for nine adult males and twelve adult females, all from the vicinity of the type locality, are, respectively:

Total length, 168, 163; length of tail, 92, 89; length of hind foot, 22, 22; height of ear from notch, 8, 8; greatest length of skull, 24.8, 24.6; condylobasal length, 21.1, 21.0; length of maxillary tooth row, 3.4, 3.4; zygomatic breadth, 13.1, 12.8; interorbital breadth, 6.1, 6.3; mastoid breadth, 12.3, 12.1; greatest crown breadth across upper molar rows, 4.4, 4.3.

*Remarks.*—Seemingly no collector of mammals has previously visited the desert plains of central San Luis Potosí where this race of *Perognathus penicillatus* is found and where the species seems to reach its southernmost limit of distribution.

*Specimens examined.*—Total number, 36, from: 7 km west of Presa de Guadalupe, 9; Presa de Guadalupe, 23 (10 skulls only); 7 km southeast of Presa de Guadalupe, 2; 16 km northwest of Ciudad del Maíz, 2.

***Perognathus lineatus*, n. sp.**

**LINED POCKET MOUSE**

*Type.*—Adult male, skin and skull no. 5253, Louisiana State University Museum of Zoology; obtained 1 km south of Arriaga, San Luis Potosí, México, by Walter W. Dalquest on September 21, 1950; original number, 14734.

*Range.*—The desert plains of western and central San Luis Potosí and, doubtlessly, adjacent parts of Guanajuato, Zacatecas, and Jalisco.

*Description.*—A medium-sized, slim-bodied pocket mouse, with a crested tail longer than head and body, and lacking long, stiff spines in the pelage of the rump area; color of upperparts dull gray, finely but distinctly lined with buffy, especially on head; general appearance of upperparts near Light Drab or Drab Gray; sides more grayish; underparts white separated from gray of sides by faint, indistinct line of pale buffy; tail dusky above and white beneath.

*Comparisons.*—*Perognathus lineatus* differs from *P. n. nelsoni* Merriam in its distinctive coloration and the absence of long, stiff spines in the pelage of the rump area, but it resembles *nelsoni* in size, proportions, and cranial characters. Among the species of pocket mice that lack spines in the rump area, *lineatus* most closely resembles *penicillatus* but differs from at least the geographically adjacent races of that species in its distinctive coloration, larger size, and larger, broader skull. *Perognathus lineatus* has been taken in the same trap lines with both *P. penicillatus* and *P. nelsoni*.

*Measurements.*—The arithmetic means for eight males and seven females are, respectively: Total length, 174, 174; length of tail, 95, 98; length of hind foot, 23, 23; height of ear from notch, 8, 8; greatest length of skull, 25.4, 25.4; condylobasal length, 21.8, 21.5; length of maxillary tooth row, 3.6, 3.8; zygomatic breadth, 13.1, 13.1; interorbital breadth, 6.3, 6.3; mastoid breadth, 12.7, 12.5; greatest crown breadth across upper molar rows, 4.6, 4.6.

*Specimens examined.*—Total number, 29, from: Cerro Peñon Blanco, 6; 6 km south of Matehuala, 1; 1 km south of Arriaga, 13; Bledos, 8 (1 skull only); 10 km northwest of Villar, 1.

*Oryzomys alfaroi huastecae*, n. subsp.

*Type.*—Adult male, skin and skull no. 5436, Louisiana State University Museum of Zoology; obtained 10 km east of Platanito, San Luis Potosí, México, by Walter W. Dalquest on November 13, 1950; original number, 15643.

*Range.*—The tropical, eastern slopes of the Sierra Madre Oriental in eastern San Luis Potosí.

*Description.*—A small, slim-bodied, long-tailed, dark-colored rice rat; total length about 200 mm; tail slim and nearly naked; claws of hind feet nearly concealed by long, white bristles; color of upperparts Bister to Snuff Brown; sides slightly paler than back; ears black; underparts whitish or pale gray; tail dusky above and only slightly paler beneath.

*Comparisons.*—This subspecies is similar in size to *Oryzomys alfaroi chapmani* Thomas but is paler and browner in color. Young animals especially are less blackish than the young of other races of *Oryzomys alfaroi*. Compared with its nearest geographic neighbor, *O. a. dilutior* Merriam, *huastecae* is smaller and has a smaller, relatively narrower skull.

*Measurements.*—The arithmetic means for four adult males and two adult females are, respectively: Total length, 196, 202; length of tail, 101, 110; length of hind foot, 26, 25; height of ear from notch, 17, 17; greatest length of skull, 26.9, 27.0; condylobasal length, 23.6, 23.8; length of maxillary tooth row, 4.1, 3.7; length of palatal bridge, 4.9, 5.2; zygomatic breadth, 13.7, 13.6; interorbital breadth, 4.6, 4.6; mastoid breadth, 11.1, 10.7; greatest crown breadth across upper molar rows, 5.0, 5.1.

*Remarks.*—The discovery of this race of *Oryzomys alfaroi* extends the known range of the species northward from Huachinango, in central

Puebla, to eastern San Luis Potosí. It doubtlessly extends northward also into Tamaulipas, for specimens were taken a few miles from the boundary of that state.

*Specimens examined.*—Total number, 14, from: 10 km east of Platanito, 9 (2 skulls only); Xilitla, 2; Cerro Miramar (near Xilitla), 1; Cerro San Antonio (near Xilitla), 2.

*Neotoma ferruginea griseoventer*, n. subsp.

*Type.*—Adult female, skin and skull no. 3194, Louisiana State University Museum of Zoology; obtained at Xilitla, San Luis Potosí, México, by Marcella Newman on June 27, 1947; original number, M 29.

*Range.*—Known only from El Salto and Xilitla on the tropical, eastern slopes of the Sierra Madre Oriental in San Luis Potosí.

*Description.*—A large, coarsely-furred wood rat; first upper molar with anterointernal reentrant angle deep, reaching more than half way across anterior lobe; fur of underparts plumbeous with only faint wash of white and entirely lacking white at the bases of the hairs; color of upperparts in fresh pelage dark brown, Prout's Brown on sides and near Sepia on back; underparts Drab Gray with nearly complete pectoral band of dull Pinkish Cinnamon; feet silvery white; tail sharply bicolored, blackish above and white beneath.

*Comparisons.*—*Neotoma f. griseoventer* resembles *N. f. torquata* Ward but is larger, with larger skull and darker color, especially beneath. It most closely resembles *N. f. distincta* Bangs, from the tropical slopes of the Sierra Madre Oriental in Veracruz, but has smaller molar teeth, a more slender rostrum, and is less reddish in color. The gray underparts of *N. f. griseoventer* seem to be unique in this genus.

*Measurements.*—External measurements of the type, an adult female, are: Total length, 392; length of tail, 175; length of hind foot, 42; height of ear from notch (dry), 26. Cranial measurements of a male from El Salto, a male from Xilitla, and the type, are, respectively: greatest length of skull, 48.3, 47.6, 46.6; condylobasal length, 44.9, 45.9, 43.7; basilar length, 37.7, 40.3, 37.5; length of maxillary tooth row, 9.1, 9.5, 9.8; length of nasals, 17.4, 18.2, 17.5; length of incisive foramina, 10.5, 10.5, 8.9; zygomatic breadth, 24.1, 25.0, 22.6; interorbital breadth, 5.7, 5.5, 5.9; mastoid breadth, 18.6, 19.2, 17.4; rostral breadth, 7.7, 7.6, 8.0.

*Remarks.*—*Neotoma ferruginea* has an extensive

geographic range over the southern part of the Mexican Plateau, and in some areas it has extended its range over the lip of the plateau and into the upper edge of the tropical zone on the slopes of the Sierra Madre. Populations in the Tropics have become isolated and have evolved into strongly differentiated races. *Neotoma f. griseoventer* would seem to represent another such race were it not for the fact that no wood rats of the *ferruginea* type have been reported from the Mexican Plateau of San Luis Potosí or from the lowlands to the east. Presumably *ferruginea* once occurred in the desert ranges of western San Luis Potosí. The known distribution of

*griseoventer* suggests that it was derived from a population of those wood rats that extended their range over the Sierra Madre and into the tropics. It is highly unlikely that the tropical rats of San Luis Potosí are directly connected with the tropical rats of Veracruz (*N. f. distincta*) along the entire length of the Sierra Madre Oriental. The wood rats of the Sierra Madre of San Luis Potosí seem to be a relic population isolated far to the north of the remainder of the range of the species.

*Specimens examined.*—Total number, 3, from: El Salto, 1; Xilitla, 2.

ORNITHOLOGY.—*The systematic relationships of the fox sparrows (Passerella iliaca) of the Wasatch Mountains, Utah, and the Great Basin.* WILLIAM H. BEHLE and ROBERT K. SELANDER, Museum of Zoology, University of Utah. (Communicated by Herbert Friedmann.)

While discussing the subspecies *Passerella iliaca schistacea* in his revision of the genus, Swarth (Univ. California Publ. Zool. 21: 155. 1920) commented that the race, even as he restricted it, probably covered a composite of two or more recognizable subspecies. This remark was probably prompted by differences that he detected between examples from Canada and northern Nevada. He did not have representatives from Utah. In 1941, the late Max M. Peet acquired a single specimen of fox sparrow taken 2 miles north of Mount Pleasant, Sanpete County, Utah, on March 17, which, upon comparison with the material in the Dickey Collection, caused the late A. J. van Rossem to express the opinion that it probably represented an undescribed race. Dr. Peet thereupon attempted to assemble specimens from the Utah area so as to work out the problem in collaboration with George M. Sutton, but material in museums was still too scarce to allow them to do so. During the last two years we have succeeded in obtaining considerable material from northern Utah. Following Dr. Peet's death, inquiry was made as to the status of the research. The ornithologists at the University of Michigan Museum graciously told us to go ahead with the problem and sent their comparative material for our use. We are indebted to Drs. J. Van Tyne, Robert W. Storer, and George M. Sutton for this courtesy, and to a number of

others as follows for the loan of comparative material: Alden H. Miller, Museum of Vertebrate Zoology; Herbert Friedmann, U. S. National Museum; Robert T. Orr, California Academy of Sciences; Thomas R. Howell, Dickey Collections, University of California at Los Angeles; Kenneth C. Parkes, Cornell University Laboratory of Ornithology; C. Lynn Hayward, Brigham Young University; and Howard Knight, Weber College.

Swarth (Proc. Biol. Soc. Washington 13: 163. 1918), in describing *P. i. canescens*, stressed the gray dorsal color of the birds from the White Mountain region of eastern California in contrast to the brown color of *schistacea*. Now it is disclosed that the birds from Utah are still grayer, so much so that *canescens* looks brown in comparison. Since this is the situation with birds from several locations in the northern part of the state, we feel this extreme gray population is of racial stature and so propose the name

*Passerella iliaca swarthi*, n. subsp.

*Type.*—Adult ♂, no. 11451, University of Utah Museum of Zoology, North Fork Ogden River, 5,200 feet, 2 miles west of Eden, Weber County, Utah; April 20, 1951; collected by Robert K. Selander and William H. Behle, original number 1018 (R.K.S.); testes 10 mm.

*Subspecific characters.*—Distinguished from *P. i. schistacea* by having a decided gray color to the head and back instead of brown; streaking on



breast heavier and less rufescent. Closer to *P. i. canescens* but grayer.

*Measurements.*—Adult male (32 breeding specimens): Wing, 87.0–76.0 (81.7); tail, 88.2–76.0 (82.4); exposed culmen, 13.3–10.4 (11.8); bill from nostril, 9.6–7.9 (8.6); depth of bill, 10.8–9.0 (9.5); width of bill, 9.2–7.4 (8.2); tarsus, 25.4–21.5 (23.6); middle toe with claw, 23.4–19.4 (20.9); hind toe with claw, 20.0–16.0 (18.6) mm. Adult females (9 breeding specimens): wing, 80.0–74.0 (76.8); tail, 79.3–74.4 (76.8); exposed culmen, 12.4–10.7 (11.6); bill from nostril, 9.2–7.7 (8.4); depth of bill, 10.0–9.0 (9.5); width of bill, 9.0–7.8 (8.2); tarsus, 23.8–22.5 (23.4); middle toe with claw, 24.0–18.6 (20.6); hind toe with claw, 20.8–16.3 (18.7) mm. Measurements were taken according to the methods described by Swarth (Univ. California Publ. Zool. **21**: 83–84. 1920).

*Geographic range.*—Breeds in northern Utah and southern Idaho. Winter range unknown.

*Specimens examined.*—*Idaho*: Owyhee County: Indian Creek, 2 miles southwest of Riddle, 5,500 feet, 1 (June). Bannock County: Pocatello Creek, 3 miles east of Pocatello, 1 (April, toward *schistacea*). Bear Lake County: Paris, 2 (April). *Utah*: Rich County: 12 miles southwest of Woodruff, 1 imm. (July). Cache County: 12 miles west of Garden City, 1 imm. (July). Box Elder County: George Creek near Yost, 6,200 feet, Raft River Mountains, 4 (May); Clear Creek, 3 miles southwest of Nafton, 5 (June). Weber County: North fork of Ogden River, 2 miles west of Eden, 5,200 feet, 12 (April–May). Summit County: Chalk Creek, 5,600 feet, 5 miles east of Coalville, 1 (June); Oakley, 6,500 feet, 2 (May); Kimballs Junction, 6,900 feet, 1 (April). Wasatch County: 3 miles west of Wallsburg, 5,000 feet, 1 (April). Salt Lake County: Salt Lake City, 1 (May); 2–5 miles east of mouth of Emigration Canyon, 2 (April–May); Silver Lake Post Office (Brighton), 8,750 feet, 1 (June). Utah County: Provo, 2 (March–June). Sanpete County: 2 miles north of Mount Pleasant, 1 (March). Tooele County: Lookout Mountain, 1 imm. (July). Juab County: 10 miles northeast of Nephi, 2 (April); head of Basin Creek, 9,500 feet, east slope of Deep Creek Mountains, 6 miles east of Indian Village, 1 (June).

*Remarks.*—Until the time of Swarth's revision there was confusion concerning the type locality of the race *P. i. schistacea* and some doubt as to which population the name applied. Swarth examined the type specimen and stated (*op. cit.* 154) that it is an adult female in badly molting

plumage, of little value for color comparisons, and probably was not breeding at the place where it was collected. This was along the South Platte River in Nebraska, probably between Laramie Crossing and Goodales Crossing approximately 200 miles west of Fort Kearny. There seems little doubt from Swarth's remarks that this represents a distinctly brown bird. He noted a similarity between this type specimen, birds from the Pine Forest Mountains, Nev., and summer birds from the vicinity of Fort Bridger, Wyo. Thus, he conceived of *schistacea* occurring throughout the Great Basin as well as in the interior region to the north.

As new material accumulated it was found that this conclusion was incorrect. Linsdale (Pacific Coast Avif. **23**: 131, 1936) disclosed that the race *canescens* is not confined to the White Mountain region, but extends eastward through Esmeralda County to White Pine County, Nev. Aldrich (Proc. Biol. Soc. Washington **56**: 163–166. 1943) describes the race *olivacea* from Washington. Now it develops that this new race, *swarthi*, occupies the eastern portion of the Great Basin. The range of *swarthi* is not extensive, however, and evidence exists of clines connecting it with *schistacea* to the east, north, and northwest, and probably with *canescens* to the southwest. The southern limits of the range of the species are reached in central Utah so there is no problem of intergradation to the south.

The center of differentiation of this gray population, *swarthi*, appears to be in the Wasatch Mountains of northern Utah. Progressing eastward and northeastward there is evidence of a gradient toward a population with a brown dorsum. A breeding specimen from Chalk Creek, 5,600 feet, 5 miles east of Coalville, Summit County, Utah, is fairly gray, but one from a few miles farther northeast at 3 miles north of the Utah State line on Bear River, 7,450 feet, Uintah County, Wyo., is brown and seemingly transitional toward *schistacea*. A single specimen from Long Lake, head of Ashley Creek, Uintah County, Utah, taken in July, is an immature example, but is in nearly complete first fall plumage. It is too brown for typical *swarthi*, suggesting that the transition to *schistacea* occurs immediately east of the Wasatch Mountains in the Uintah Mountain region of eastern Utah. We have had no material from Colorado available so as to trace this cline farther east.

The birds from Fort Bridger that Swarth had and that we have examined are a puzzling lot.

They are brown and thus similar to *schistacea*, as Swarth noted. This may, however, be attributed to foxing, for the specimens were taken in 1858, and two were evidently once mounted specimens. It may be that fresh material would reveal that the fox sparrows from here are *swarthy*, but it now appears that a rather abrupt transition from *swarthy* to *schistacea* occurs between the headwaters of the Weber and Bear River drainages.

Further evidence of the transition to *schistacea* is seen in the two August specimens from Bear Lake County in southeastern Idaho which are slightly browner than topotypical examples of *swarthy* and so intergradational. A mid-August example from Afton, Wyoming, a specimen from Teton Mountain taken on August 28, and one from Teton Pass, September 11, are all referable to *schistacea*.

To the northwest, a series of breeding examples from the Raft River Mountains are closer to *swarthy* but are slightly browner than topotypical specimens. This again indicates the beginnings of a character gradient toward *schistacea*. A specimen from Pocatello Creek, Bannock County, Idaho, is almost exactly intermediate between the two races. Although taken April 2, it had testes 8 mm long and was probably on its breeding ground. It is arbitrarily placed with *swarthy*. North of this location, the fox sparrows are closer to *schistacea* which probably exists in typical form in northern Idaho. Examples from Idaho that we have examined which are referable to *schistacea* are as follows: Cottonwood Creek, 2 miles west of Craters of the Moon, Blaine County (July); Glidden Lakes, 5,700 feet, Shoshone County (July); Beaver Ridge, 6 miles south southwest Lolo Pass, 6,000 feet, Idaho County (July); Coeur d'Alene, Kootenai County (April-May); Hunt Peak, Selkirk Mountain, Boundary County (August). Also referable to *schistacea* are specimens from the Wallowa Mountain area in southeastern Oregon, the specific localities being 16 miles south and 3 miles east of Lostine, 5,500 feet, Wallowa County (July) and North Fork of the Malheur River, 15 miles east and 12 miles south of Prairie City, 5,100 feet, Baker County, Oregon (July).

Apparently *swarthy* gives way to *schistacea* as one proceeds westward across northern Nevada. A single worn specimen taken July 15 at Cedar Creek, 6,000 feet, 10 miles northeast of San Jacinto, Elko County, is like specimens of the series from the Raft River Mountains and is

probably closer to *swarthy*. Three breeding birds and several taken in September from the Santa Rosa Mountains, Humboldt County, farther to the west, are brown and thus referable to *schistacea*. They are very similar to those from the Pine Forest Mountains still farther west.

While our principal concern has been to show that these specimens from central northern and northwestern Nevada are not *swarthy*, it may not be amiss to call attention to the problem in connection with the birds of northern Nevada. Although Swarth referred the Pine Forest Mountain series to *schistacea*, he noted differences between them and examples from the Banff (Canada) region. The chief difference is that birds from the latter locality have shorter tails (see Swarth, Univ. California Publ. Zool. 21: 155, 182, 1920). He suggested that either the Banff birds are from an area of intergradation between *schistacea* and *altivagans*, with the birds from northern Nevada being truly representative of *schistacea*, or the short tailed, small billed, rufescent northern birds represent true *schistacea*, and the birds from northern Nevada belong to another race. This problem still remains undecided, and until much more material is available to bridge the intervening areas, the Pine Forest series is best referred to *schistacea*, as both Swarth and Linsdale have done.

In Swarth's table of measurements (*op. cit.* 182-183), a series of six male specimens, presumably adults, of the race *canescens* has a shorter length of bill than do series of *schistacea*. Thirty breeding male specimens of *canescens* from Esmeralda, Nye, and Lander Counties, Nev., were measured by us with results as follows: Wing, 83.3-77.1 (81.4); tail, 86.2-75.6 (80.9); exposed culmen, 12.3-10.0 (11.2); bill from nostril, 9.4-7.6 (8.5); depth of bill, 10.0-8.4 (9.3); width of bill, 8.8-7.6 (8.2); tarsus, 25.8-20.2 (23.3); middle toe with claw, 23.0-17.5 (20.4); hind toe with claw, 19.8-16.0 (18.0) mm.

This lot of *canescens* and our series of *swarthy* are therefore comparable in size, and furthermore, they are essentially the same size as the Pine Forest Mountain series representing *schistacea*. It was noted that the immature specimens in the topotypical series of *canescens* have smaller bills than do the adults. Nine adult male topotypes or near topotypes of *canescens* have the following measurements: exposed culmen, 11.7-10.3 (11.3); bill from nostril, 9.0-7.8 (8.3); depth of bill, 10.6-9.0 (9.6); width of bill, 8.8-8.3 (8.5) mm.

This further corroborates the lack of significant differences in size of bill between the three races, *canescens*, *swarthi* and *schistacea*.

The material available is inadequate for working out the details of the transition between *swarthi* and *canescens*, which probably takes place in the mountains of central eastern Nevada between the Snake and Toyabe Mountains. A single breeding specimen from the Deep Creek Mountains in extreme western Utah is referable to *swarthi*. In addition to a gray dorsum it has an unusually heavily marked breast with dark, slate colored blotches. A single specimen from the Snake Range in Nevada, a short distance to the south of the Deep Creek Mountains, taken September 22, is brown and referable to *schistacea*. It was, however, probably a transient. Breeding birds from Kingston Creek in the Toyabe Mountains are brown and thus represent *canescens*.

The distribution of the races of fox sparrows in Nevada remains, then, as Linsdale (*op. cit.*) has indicated, except that the breeding birds of the Snake Range probably represent *swarthi*.

Some other examples of fall transients of *schistacea* from the breeding range of *swarthi* are two from 4 miles northeast of Ogden, 8,000 feet, taken September 22 and 29. Several early April atypical examples of *swarthi* are probably transients from areas of intergradation between that race and *schistacea*.

The places of occurrence and ecological relationships of fox sparrows of the race *swarthi* are essentially as Linsdale (*Amer. Midl. Nat.* **19**: 167-170. 1938) described for the race *canescens* in the Toyabe Mountains of Nevada, thus being further indicative of the close relationship between *canescens* and *swarthi*.

#### ZOOLOGY.—*Two new species of incrusting ctenostomatous Bryozoa from the Pacific.*<sup>1</sup>

JOHN D. SOULE, Allan Hancock Foundation, Los Angeles, Calif. (Communicated by Waldo L. Schmitt.)

Examination of specimens dredged recently from the Arctic Ocean off Point Barrow, Alaska, by the Arctic Research Laboratory and off the coast of southern California by the Allan Hancock Foundation has revealed two species of ctenostomatous bryozoans of the group *Carnosa* which are believed to be new.

Family ALCYONIDIIDAE Hincks, 1880

*Alcyonidium enteromorpha*, n. sp.

*Diagnosis*.—Zoarium robust, coriaceous, linear, flexuous, measuring 61 cm in length and 4 to 6 mm in width, anchored directly to the substratum without evidence of a peduncle. Cuticle moderately thick. Zooecia irregular, ranging in shape from rectangular to hexagonal. No raised oral papillae. Polypide with 17 tentacles.

*Description*.—Macroscopically the chitinous, leathery zoaria superficially resemble the intestinal tract of a small mammal, being unusually elongate, without lateral branching. Coiled in several loose folds, gutlike, and attached to the substratum without the benefit of a peduncle. The cuticle is firm, mottled light brown to tan, and only moderately thick. The zoaria have a central cavity filled with a loose reticular packing

tissue in which may be found numerous brown-bodies. The zooecia are well defined, easily found in the portions of a zoarium where the cuticle is thin. However, on the greater part of a zoarium the lateral zooecial walls can be only faintly discerned, and while not totally obscured they are somewhat difficult to trace. The ventral zooecial wall is smooth with no oral papillae present. The dorsal wall is thin to the point of transparency. In shape the zooecia are quite variable, ranging from rectangular to irregularly hexagonal, those containing mature polypides measuring between 230 $\mu$  to 403 $\mu$  in length, and 115 $\mu$  to 253 $\mu$  in width. The polypide itself in no way deviates morphologically from the normal anatomical pattern typical of the genus *Alcyonidium* s.s. The tentacle number determined by serial sections is 17. Whole mounts of several individual polypides, as well as sections, were prepared, stained and examined for evidence of a gizzard. Polypides of *A. polyoum* (Hassall) and *A. pedunculatum* Robertson were mounted for purposes of comparison.

The species described above differs from *Alcyonidium* (*Paralcyonidium*) *vermiculare* Okada, 1925, in the following ways: (1) The zoarium is larger, with a uniform width of 4 to 6 mm as against 2 to 3 mm for *A. vermiculare*; (2) the polypide does not have a gizzard, as is described for *A. vermiculare*; (3) the tentacle number is

Contribution no. 63 from the Allan Hancock Foundation, University of Southern California.

17 as against 20 found in *A. vermiculare*. It differs from *Alcyonidium pedunculatum* Robertson, 1902, by virtue of its extreme zoarial length and its lack of a peduncle.

*Types*.—Holotype: U. S. N. M. no. 10981. Paratypes in the Allan Hancock Foundation, University of Southern California, Los Angeles, Calif.

*Type locality*.—Off Point Barrow, Alaska; August 17, 1949, 12.1 miles out, depth 741 feet. Collector, G. E. MacGinitie, Arctic Research Laboratory.

*Additional distribution*.—Off Point Barrow, Alaska, September 6, 1949, depth 477 feet. Same collector.

Family FLUSTRELLIDAE Hincks, 1880

Genus *Pherusella*, n. name

In 1816 Lamouroux erected the genus *Pherusa* into which he placed the *Flustra tubulosa* of Solander, 1786. However, it has since been found that *Pherusa* Lamouroux, 1816, is a homonym of *Pherusa* Oken, 1807. The name *Pherusa* has also been used by Leach, 1814, Crustacea, and by Rafinesque, 1815, Mollusca. In 1887, Pergens also used the name *Pherusa* for Bryozoa but without descriptions or figures.

Since the *Pherusa* of Lamouroux is unquestionably preoccupied, it is therefore necessary to introduce a new name, and also to redefine and amend the description published by Lamouroux. The original description by Lamouroux, 1816, is as follows: "Pheruse. *Pherusa*. Polypier frondescent, multifide; cellules oblongues et saillantes sur une seule face; ouverture irrégulière; bord contourné."

Zoaria coriaceous, incrusting, or from incrustations arising in branching flabellate projections.

Zooecia elongate, rectangular to hexagonal with zoecial walls well defined. The distal ends of the zooecia rise into prominent tubular projections, bearing upon the upper ends the apertures which, when the polypide is retracted, appear square to transversely quadrangular in shape. The length of this tubular projection is relatively constant within a species.

The ventral wall is generally smooth. The lateral walls of the zooecia are characterized by interzoecial communication pores. These pores are very distinct, owing to the presence of heavy chitinous rims, which are a dark brown in contrast with the tan color of the walls. When examined from the dorsal aspect, these pores

form a regular pattern following the zoecial borders.

In the generic description by Lamouroux it is stated that the apertures were found on one surface only. Bilaminar, back to back, specimens, as well as unilaminar specimens, have been found in erect zoaria when the growth of the zoaria exceeds the limits of the algae upon which they are incrustated. Thornely (1905, p. 127) observed this type of growth on *P. tubulosa* collected in Asiatic waters.

*Pherusella tubulosa* (Solander), 1786, not represented at this time in the eastern Pacific collections, the sole species for over a hundred years, is the genotype. The genus now includes *Pherusella tubulosa* (Solander), 1786, *Pherusella flabellaris* (Kirkpatrick), 1890, and the new species described below. *Alcyonidium flustrelloides* Barroso, 1920, is a junior synonym of *P. tubulosa*.

*Pherusella brevituba*, n. sp.

*Diagnosis*.—Zoaria chitinous, incrusting or arising from an incrustation in wide, flat, flabellate expansions, which measure up to 6.0 cm in height and from 1.5 to 2.5 cm in width. Zooecia are distinct, elongate, variable in shape from an irregular rectangle to a hexagon. The lateral zoocial walls are perforated by interzoecial communication pores which have a distinct chitinous ring. The aperture is borne on a distally located, raised tubular prominence whose upper extremity is square or transversely quadrangular when the polypide is retracted. This tubular projection is short, rising only 250 $\mu$  to 300 $\mu$  in height. Tentacles number 23.

*Description*.—The zoaria are a light brown in color, chitinous, leathery in appearance, and form heavy incrustations upon the holdfasts and blades of algae. When the zoaria are strictly incrusting they are unilaminar, or they may form erect fanlike fronds that are bilaminar, back to back, where the zoarial growth exceeds the limits of the algal thalli.

The zooecia are elongate with considerable variation in shape from imperfectly rectangular to hexagonal, averaging about 800 $\mu$  in length and 400 $\mu$  in width. Normally the individual zooecia are distinct, clearly defined by the lateral walls. The lateral walls are perforated by well-marked interzoecial communication pores whose diameter averages 27 $\mu$ . By examining the zooecia from the dorsal side in a unilaminar zoarium, or by careful focusing on a bilaminar zoarium, these

communication pores will be seen to form a regular pattern on the lateral walls of the zooecia. The rims of the communication pores are strengthened by heavy chitinous rings. Within

this ring are four minute perforations piercing a thin chitinous diaphragm.

The distal portion of each zooecium is raised to form a short but prominent tubular process

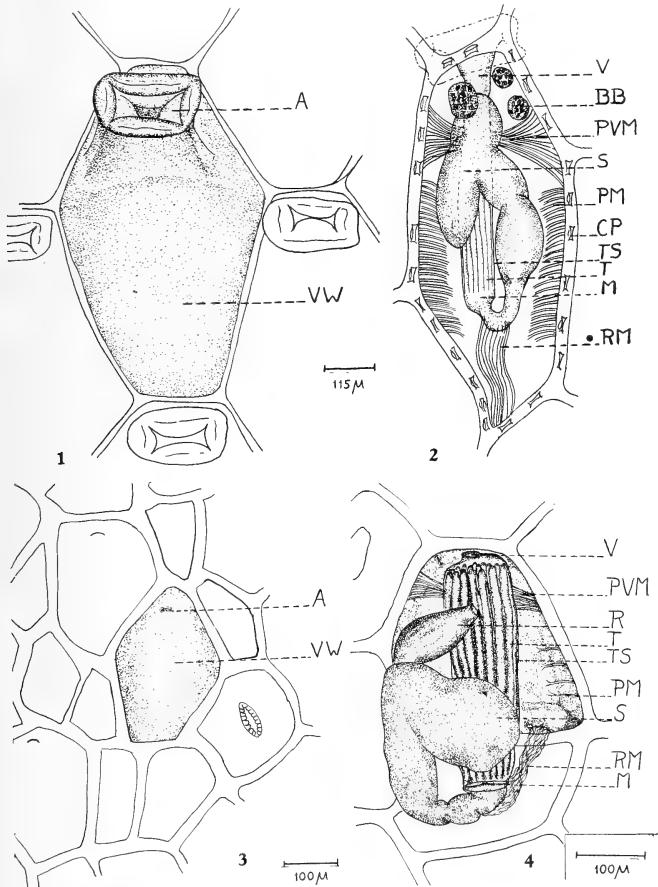

FIGS. 1-4.—1, *Pherusella brevituba*, n. sp., ventral aspect of a zooecium, showing the raised tubular projection bearing the aperture; 2, same, dorsal view, drawn from a unilaminar zoarium, showing the anatomy of the polypide within a zooecium; 3, *Alcyonidium enteromorpha*, n. sp., ventral aspect of a portion of a zoarium; 4, same, dorsal view, showing the anatomy of a polypide within a zooecium. (A, aperture; BB, brown-body; CP, communication pore; M, mouth; PM, parietal muscle; PVM, parieto-vaginalis muscle; R, rectum; RM, retractor muscle; S, stomach; T, tentacle; TS, tentacle sheath; V, vestibule; VW, ventral wall.) Drawings by Dorothy F. Soule.

which bears the aperture. When the polypide is withdrawn into the zoecium this tubular projection appears square to transversely quadrangular. When the polypide is extruded the tentacle sheath further extends the reach of the tentacles. The tentacles were found to consistently number 23 in sectioned material.

The new species is distinguished from *P. tubulosa* (Solander), 1786, by its short tubular processes and its tentacle number. In *P. tubulosa* the tentacle number is 28 (Prouho, 1892). It is distinguished from *P. flabellaris* (Kirkpatrick), 1890, which like Solander's species has lengthy tubular processes 0.6 mm in height, but has only 20 tentacles.

*Holotype*.—AHF no. 55. Colony incrusting upon the holdfast and blades of *Halidrys* sp.? (marine alga).

*Type locality*.—Hancock Foundation station 1909-49, east of Portuguese Bend, Calif., lat. 33° 43' 00" N., long. 118° 19' 57" W.; 8 to 7.5 fathoms; bottom rocky, November 6, 1949; collector, J. D. Soule.

*Additional distribution*.—(1) Santa Barbara-San Luis Obispo County line; washed ashore on holdfast of *Halidrys*; August 2, 1939; collector, A. Sorensen. (2) Punta Baja, near Rosario, Baja California, tide pool; substratum unknown; April 9, 1946; collector, E. Y. Dawson.

ZOOLOGY.—*The number of species of decapod and stomatopod Crustacea*.<sup>1</sup> FENNER

A. CHACE, JR., U. S. National Museum.

As part of a collaborative effort to list the number of species belonging to each of the major groups of the Animal Kingdom for a proposed biological handbook, a fairly intensive survey was made of the Recent species of shrimps, lobsters, anomurans, crabs, and mantis shrimps. No such count of the decapod crustaceans seems to have been attempted in the past. It may be useful, therefore, to present the results of this survey in more complete form than they will appear in the handbook and to indicate the measures taken to insure a reasonably accurate coverage of the higher crustaceans.

The files on decapod and stomatopod crustaceans in the U. S. National Museum are unusually valuable for a survey of this

<sup>1</sup>Published by permission of the Secretary of the Smithsonian Institution.

#### LITERATURE CITED

- BARROSO, M. G. *Notas sobre briozoos españoles*. Bol. Real Soc. Esp. Hist. Nat. **20**: 353-362, 4 figs. 1920.
- KIRKPATRICK, R. *Report upon the Hydrozoa and Polyzoa collected by P. W. Bassett-Smith, Esq., Surgeon R. N., during the survey of the Tizard and Maclesfield Banks in the China Sea, by H.M.S. Rambler, Commander W. U. Moore*. Ann. Mag. Nat. Hist. (6) **5**: 11-24, 3 pls. 1890.
- LAMOUREUX, J. V. F. *Histoire des polypiers coralligènes flexibles, vulgairement nommés zoophytes*: LXXXIV + 559 pp., 19 pls. Caen, 1816.
- OKADA, Y. *Acyonidium* (Paralecyonidium) vermiculare, a new sub-genus and species of ctenostomatous Bryozoa. Ann. Zool. Japon. **10** (pt. 7, art. 28): 281-284, fig. 5, abc. 1925.
- PERVENS, E. *Contributions à l'histoire des bryozoaires et des hydrozoaires récents*. Ann. Soc. Roy. Malacol. Belgique (Bull. Seances 1887) **22**: LXXXVII. 1887.
- PROUHO, H. *Contribution à l'histoire bryozoaires*. Arch. Zool. Exp. (2) **10**: 557-556, 8 pls. 1892.
- . *Some observations on Ascorhiza occidentalis Fewkes and related Acyonidia*. Proc. California Acad. Sci. (zool. ser. 3) **3** (3): 99-108, pl. 14, figs. 1-9. 1902.
- SOLANDER, D. *Natural history of many curious and uncommon zoophytes, collected from various parts of the globe by the late John Ellis, systematically arranged and described by the late D. Solander*. London, 1783.
- THORNELEY, L. R. *Report on the Polyzoa collected by Prof. Herdman at Ceylon in 1902*. Rep. Pearl Oyster Fisheries Gulf of Manaar, suppl. rep. 26, Polyzoa, pt. 4. Royal Society, London, 1905.

kind because of continued interest in the groups by one or more members of the staffs of the division of marine invertebrates for well over half a century. A systematic card catalogue expanded and amended from entries in the Zoological Record was used as the basis for the compilation. This was supplemented by reference to published generic revisions; to extensive unpublished notes and species lists which were initially accumulated by Dr. Mary J. Rathbun during her many years of active carcinological work and which have been continued and expanded by Dr. Waldo L. Schmitt; to an invaluable manuscript synonymy of the caridean shrimps compiled by Dr. L. B. Holthuis, of the Rijksmuseum van Natuurlijke Historie, Leiden, Holland; and to a manuscript summary of the crayfishes

of the world prepared by Dr. Horton H. Hobbs, Jr., of the Miller School of Biology, University of Virginia. Because of the lack of published revisions of a large proportion of the decapod genera, the results of this review would be very much less significant without the contributions of these four carcinologists.

As there is still a lag of several years between the appearance of scientific papers and their abstraction by the Zoological Record and as the disruption in the exchange of publications caused by the last world war has not yet been completely remedied, only those species described through the year 1945 have been counted. In general, only full species are included, although it must be admitted that a large number of crustacean subspecies and varieties will be elevated to specific rank when relationships become better known. It is of course impossible to arrive at definitive counts for most invertebrate groups. Differences of opinion as to the validity of many genera and species will persist until more complete collections are available for study and more workers have had an opportunity to review the evidence.

The classification in the following table follows the system accepted by most carcinologists today. There has been some criticism from workers in other groups of the use of the "tribe" as a superfamilial category. Justifiable though this criticism may be, it is felt that any change in the generally accepted classification of the Crustacea should await an over-all revision of that entire complex class. The subtribes and superfamilies have been intentionally omitted because of the lack of agreement about the limits of several of them and not because of any belief that they are not desirable for an understanding of decapod relationships.

NUMERICAL DISTRIBUTION OF THE RECENT  
GENERA AND SPECIES OF DECAPOD  
AND STOMATOPOD CRUSTACEA

	<i>Genera</i>	<i>Species</i>
ORDER DECAPODA	1,001	8,321
Suborder Natantia (shrimps)	211	1,930
Tribe Penaeidea	33	318
Family Penaeidae	27	231
Family Sergestidae	6	87

*Genera Species*

ORDER DECAPODA—Continued.		
Suborder Natantia (shrimps)—Continued.		
Tribe Caridea	171	1,590
Family Pasiphaeidae	7	60
Family Styloactylidae	1	7
Family Atyidea	21	137
Family Oplophoridae	6	54
Family Nematocarcinidae	1	17
Family Bresiliidae	2	2
Family Disciadidae	1	3
Family Processidae	2	15
Family Pandalidae	14	112
Family Thalassocaridae	1	2
Family Psalidopodidae	1	3
Family Crangonidae	20	399
Family Hippolytidae	28	200
Family Rhynehocinetidae	1	7
Family Campylonotidae	2	6
Family Palaemonidae	46	380
Family Gnathophyllidae	4	13
Family Glyphocrangonidae	1	35
Family Crangonidae	10	136
Family Eugonatonotidae	1	1
Family Physetocaridae	1	1
Tribe Stenopodidea	7	22
Family Stenopodidae	7	22
Suborder Reptantia	790	6,391
Tribe Palinura	16	123
Family Eryonidae	2	39
Family Palinuridae (spiny lobsters)	8	35
Family Scyllaridae (Spanish lobsters)	6	49
Tribe Astacura	25	313
Family Homaridae (lobsters)	7	32
Family Austroastacidae (crayfishes)	1	2
Family Parastacidae (crayfishes)	10	76
Family Astacidae (crayfishes)	7	203
Tribe Anomura	114	1,527
Family Aeglididae	1	20
Family Chirostylidae	3	69
Family Galatheidae	6	258
Family Porcellanidae	17	225
Family Axiidae	9	84
Family Axianassidae	1	2
Family Laomedidae	3	6
Family Callianassidae (mud shrimps)	6	160
Family Thalassinidae	1	5
Family Pylochelidae	5	17
Family Paguridae (hermit crabs)	38	555
Family Coenobitidae (hermit crabs)	2	17
Family Lithodidae (king crabs)	15	53
Family Albuneidae	4	31
Family Hippidae	3	25
Tribe Brachyura (true crabs)	635	4,428
Family Raninidae	10	30

	<i>Genera Species</i>	
ORDER DECAPODA—Continued.		
Suborder Reptantia—Continued.		
Family Homolodromiidae	4	6
Family Dromiidae	18	156
Family Dynomenidae	2	13
Family Thelxiopeidae	6	16
Family Latreillidae	3	9
Family Hapalocarcinidae (coral gall crabs)	3	12
Family Dorippidae	10	77
Family Calappidae (box crabs)	10	65
Family Leucosiidae (purse crabs)	40	338
Family Euryalidae	6	14
Family Portunidae (swim- ming crabs)	38	297
Family Potamonidae (fresh- water crabs)	13	520
Family Atelecyclidae	13	30
Family Cancridae (rock crabs)	2	22
Family Xanthidae	133	928
Family Goneplacidae	54	170
Family Pinnotheridae (pea crabs)	26	222
Family Retroplumidae	1	4
Family Cymopoliidae	3	39
Family Grapsidae	40	333
Family Gecarcinidae (land crabs)	6	20
Family Ocypodidae (ghost crabs, fiddler crabs)	19	231
Family Hymenosomidae	9	53
Family Majidae (spider crabs)	145	673
Family Parthenopidae	21	150
Order Stomatopoda	8	178
Family Squillidae (mantis shrimps)	8	178

The total of approximately 8,321 recognized species of decapods agrees almost exactly with the estimate of "over 8,000 living species" cited by Pratt in 1935.<sup>2</sup> However,

<sup>2</sup> PRATT, H. S., *A manual of the common invertebrate animals exclusive of insects*, rev. ed.: 447-467. 1935.

the numbers of genera and species assigned by Pratt to several of the subordinal groups do not correspond as closely with the figures in the preceding table.

The Decapoda make up by far the largest order of the Crustacea; very nearly one-third of the accepted recent crustaceans belong to this group. It is likely that the number of species of decapods will increase by 30 or 40 percent when all living forms are recognized. Some of the other crustacean groups which have received attention for shorter periods of time possibly contain more undescribed species, but the position of the decapods as the largest and most diversified order of the class will probably never be seriously challenged.

It may be of interest that the number of decapods now known approximates Mayr's count of the number of full species of birds (8,616).<sup>3</sup> The numbers of bird families (160) and genera (1,800-2,600), however, are fully twice as large as those of the decapods. The average genus of birds therefore contains only 3.3 to 4.75 species, whereas the average decapod genus is made up of 8.3 species. This discrepancy probably does not reflect any great dissimilarity between the specific relationships of birds and decapods. Because of the extreme diversification of the decapods, it would seem safe to assume that intense systematic attention to that group, similar to that which has been focused on birds for so long, would result in an even larger proportionate number of families and genera among the decapods than among the birds.

<sup>3</sup> MAYR, ERNST, *The number of species of birds*. Auk 63: 64-59. 1946.



## Officers of the Washington Academy of Sciences

*President*.....NATHAN R. SMITH, Plant Industry Station  
*President-elect*.....WALTER RAMBERG, National Bureau of Standards  
*Secretary*.....F. M. DEFANDORF, National Bureau of Standards  
*Treasurer*.....HOWARD S. RAPPLEYE, U. S. Coast and Geodetic Survey  
*Archivist*.....JOHN A. STEVENSON, Plant Industry Station  
*Custodian and Subscription Manager of Publications*  
 HARALD A. REHDER, U. S. National Museum

### *Vice-presidents Representing the Affiliated Societies:*

Philosophical Society of Washington.....EDWARD U. CONDON  
 Anthropological Society of Washington.....WALDO R. WEDEL  
 Biological Society of Washington.....  
 Chemical Society of Washington.....JOSEPH J. FAHEY  
 Entomological Society of Washington.....FREDERICK W. POOS  
 National Geographic Society.....ALEXANDER WETMORE  
 Geological Society of Washington.....LEASON H. ADAMS  
 Medical Society of the District of Columbia.....  
 Columbia Historical Society.....GILBERT GROSVENOR  
 Botanical Society of Washington.....E. H. WALKER  
 Washington Section, Society of American Foresters.....WILLIAM A. DAYTON  
 Washington Society of Engineers.....CLIFFORD A. BETTS  
 Washington Section, American Institute of Electrical Engineers  
 FRANCIS M. DEFANDORF  
 Washington Section, American Society of Mechanical Engineers.....RICHARD S. DILL  
 Helminthological Society of Washington.....L. A. SPINDLER  
 Washington Branch, Society of American Bacteriologists.....ANGUS M. GRIFFIN  
 Washington Post, Society of American Military Engineers.....HENRY W. HEMPLE  
 Washington Section, Institute of Radio Engineers.....HERBERT G. DORSEY  
 District of Columbia Section, American Society of Civil Engineers  
 MARTIN A. MASON

### *Elected Members of the Board of Managers:*

To January 1952.....W. F. FOSHAG, C. L. GAZIN  
 To January 1953.....C. F. W. MUESEBECK\*, A. T. MCPHERSON  
 To January 1954.....SARA E. BRANHAM, MILTON HARRIS\*

*Board of Managers*.....All the above officers plus the Senior Editor

*Board of Editors and Associate Editors*.....[See front cover]

*Executive Committee*.....N. R. SMITH (chairman), WALTER RAMBERG, H. S. RAPPLEYE,  
 J. A. STEVENSON, F. M. DEFANDORF

*Committee on Membership*.....E. H. WALKER (chairman), M. S. ANDERSON, R. E.  
 BLACKWELDER, R. C. DUNCAN, G. T. FAUST, I. B. HANSEN, D. B. JONES, DOROTHY  
 NICKERSON, F. A. SMITH, HEINZ SPECHT, ALFRED WEISSLER  
*Committee on Meetings*.....MARGARET PITTMAN (chairman), NORMAN BEKKEDAHL,  
 W. R. CHAPLINE, D. J. DAVIS, F. B. SCHEETZ, H. W. WELLS

### *Committee on Monographs:*

To January 1952.....J. R. SWALLEN (chairman), PAUL H. OEHSEER  
 To January 1953.....R. W. IMLAY, P. W. OMAN  
 To January 1954.....S. F. BLAKE, F. C. KRACEK

*Committee on Awards for Scientific Achievement* (GEORGE P. WALTON, general chairman):

For the Biological Sciences.....G. H. COONS (chairman), J. E. FABER, JR.,  
 MYRNA F. JONES, F. W. POOS, J. R. SWALLEN  
 For the Engineering Sciences.....R. S. DILL (chairman), ARSHAM AMIRIKIAN,  
 J. W. MCBURNEY, FRANK NEUMANN, A. H. SCOTT  
 For the Physical Sciences.....G. P. WALTON (chairman), F. S. BRACKETT,  
 G. E. HOLM, C. J. HUMPHREYS, J. H. McMILLEN  
 For Teaching of Science.....B. D. VAN EVERA (chairman), R. P. BARNES,  
 F. E. FOX, T. KOPPANYI, M. H. MARTIN, A. T. MCPHERSON  
*Committee on Grants-in-aid for Research*.....L. E. YOCUM (chairman),  
 M. X. SULLIVAN, H. L. WHITTEMORE

### *Committee on Policy and Planning:*

To January 1952.....J. I. HOFFMAN (chairman), M. A. MASON  
 To January 1953.....W. A. DAYTON, N. R. SMITH  
 To January 1954.....H. B. COLLINS, JR., W. W. RUBEY

### *Committee on Encouragement of Science Talent:*

To January 1952.....M. A. MASON (chairman), A. T. MCPHERSON  
 To January 1953.....A. H. CLARK, F. L. MOHLER  
 To January 1954.....J. M. CALDWELL, W. L. SCHMITT

*Representative on Council of A. A. A. S.*.....F. M. SETZLER

*Committee of Auditors*.....J. H. MARTIN (chairman), N. F. BRAATEN, W. J. YOUSEN

*Committee of Tellers*.....W. G. BROMBACHER (chairman), A. R. MERZ, LOUISE M. RUSSELL

\* Appointed by Board to fill vacancy.

## CONTENTS

	Page
ETHNOLOGY.—Linguistic history and ethnologic history in the Southwest. GEORGE L. TRAGER.....	341
PALEONTOLOGY.—New Western Hemisphere occurrences of fossil selachians. DAVID H. DUNKLE.....	344
ENTOMOLOGY.—Phylogeny and biogeography of the caddisflies of the genera <i>Agapetus</i> and <i>Electragapetus</i> (Trichoptera: Rhyacophilidae). HERBERT H. ROSS.....	347
HERPETOLOGY.—Studies on the lizard family Xantusiidae, II: Geographical variation in <i>Xantusia riversiana</i> from the Channel Islands of California. JAY M. SAVAGE.....	357
MAMMALOLOGY.—Six new mammals from the state of San Luis Potosí, Mexico. WALTER W. DALQUEST.....	361
ORNITHOLOGY.—The systematic relationships of the fox sparrows ( <i>Passerella iliaca</i> ) of the Wasatch Mountains, Utah, and the Great Basin. WILLIAM H. BEHLE and ROBERT K. SELANDER.....	364
ZOOLOGY.—Two new species of incrusting ctenostomatous Bryozoa from the Pacific. JOHN D. SOULE .....	367
ZOOLOGY.—The number of species of decapod and stomatopod Crustacea. FENNER A. CHACE, JR.....	370

06.75  
D2WB3

VOL. 41

DECEMBER 1951

No. 12

# JOURNAL

OF THE

# WASHINGTON ACADEMY OF SCIENCES

### BOARD OF EDITORS

CHARLES DRECHSLER  
PLANT INDUSTRY STATION  
BELTSVILLE, MD.

WILLIAM F. FOSHAG  
U. S. NATIONAL MUSEUM

J. P. E. MORRISON  
U. S. NATIONAL MUSEUM

### ASSOCIATE EDITORS

J. C. EWERS  
ANTHROPOLOGY

C. W. SABROSKY  
ENTOMOLOGY

F. A. CHACE, JR.  
BIOLOGY

J. I. HOFFMAN  
CHEMISTRY

T. P. THAYER  
GEOLOGY

MIRIAM L. BOMHARD  
BOTANY

R. K. COOK  
PHYSICS AND MATHEMATICS

PUBLISHED MONTHLY

BY THE

WASHINGTON ACADEMY OF SCIENCES

MOUNT ROYAL & GUILFORD AVES.

BALTIMORE, MARYLAND



Entered as second class matter under the Act of August 24, 1912, at Baltimore, Md.  
Acceptance for mailing at a special rate of postage provided for in the Act of February 28, 1925  
Authorized February 17, 1949

## Journal of the Washington Academy of Sciences

This JOURNAL, the official organ of the Washington Academy of Sciences, publishes: (1) Short original papers, written or communicated by members of the Academy; (2) proceedings and programs of meetings of the Academy and affiliated societies; (3) notes of events connected with the scientific life of Washington. The JOURNAL is issued monthly. Volumes correspond to calendar years.

*Manuscripts* may be sent to any member of the Board of Editors. It is urgently requested that contributors consult the latest numbers of the JOURNAL and conform their manuscripts to the usage found there as regards arrangement of title, subheads, synonymies, footnotes, tables, bibliography, legends for illustrations, and other matter. Manuscripts should be typewritten, double-spaced, on good paper. Footnotes should be numbered serially in pencil and submitted on a separate sheet. The editors do not assume responsibility for the ideas expressed by the author, nor can they undertake to correct other than obvious minor errors.

*Illustrations* in excess of the equivalent (in cost) of one full-page halftone are to be paid for by the author.

*Proof.*—In order to facilitate prompt publication one proof will generally be sent to authors in or near Washington. It is urged that manuscript be submitted in final form; the editors will exercise due care in seeing that copy is followed.

*Unusual cost* of foreign, mathematical, and tabular material, as well as alterations made in the proof by the author, may be charged to the author.

*Author's Reprints.*—Reprints will be furnished in accordance with the following schedule of prices (approximate):

Copies	4 pp.	8 pp.	12 pp.	16 pp.	20 pp.	Covers
100	\$3.25	\$6.50	\$ 9.75	\$13.00	\$16.25	\$3.00
200	6.50	13.00	19.50	26.00	32.50	6.00
300	9.75	19.50	29.25	39.00	48.75	9.00
400	13.00	26.00	39.00	52.00	65.00	12.00

*Subscriptions* or requests for the purchase of back numbers or volumes of the JOURNAL or the PROCEEDINGS should be sent to HARALD A. REHDER, Custodian and Subscription Manager of Publications, U. S. National Museum, Washington 25, D. C.

*Subscription Rates* for the JOURNAL.—Per year..... **\$7.50**

Price of back numbers and volumes:	Per Vol.	Per Number
Vol. 1 to vol. 10, incl.—not available.*	—	—
Vol. 11 to vol. 15, incl. (21 numbers per vol.)	\$10.00	\$0.70
Vol. 16 to vol. 22, incl. (21 numbers per vol.)	8.00	0.60
Vol. 23 to current vol. (12 numbers per vol.)	7.50	0.90

\* Limited number of complete sets of the JOURNAL (vol. 1 to vol. 41, incl.) available for sale to libraries at \$348.50.

MONOGRAPH No. 1, "The Parasitic Cuckoos of Africa," by Herbert Friedmann. **\$4.50**

PROCEEDINGS, vols. 1-13 (1899-1911) complete..... **\$25.00**

Single volumes, unbound..... **2.00**

Single numbers..... **.25**

*Missing Numbers* will be replaced without charge provided that claim is made to the Treasurer within 30 days after date of following issue.

*Remittances* should be made payable to "Washington Academy of Sciences" and addressed to the Treasurer, H. S. RAFFLEYE, 6712 Fourth Street, N.W., Washington 12, D.C.

*Exchanges.*—The Academy does not exchange its publications for those of other societies.

# JOURNAL

## OF THE

# WASHINGTON ACADEMY OF SCIENCES

VOLUME 41

December 1951

No. 12

PETROLOGY.—*Thermochemistry of mineral substances, I: A thermodynamic study of the stability of jadeite.* F. C. KRACEK, K. J. NEUVONEN,<sup>1</sup> and GORDON BURLEY, Geophysical Laboratory.

The sodium aluminosilicate compound  $\text{NaAl}(\text{SiO}_3)_2$ , which in its natural crystalline form is known as the mineral jadeite, has not yet been crystallized in the laboratory. All attempts to devitrify a melt of this composition to jadeite, as well as attempts to produce the compound by more elaborate methods, have failed. The various experimental trials, both dry and hydrothermal, are discussed in detail, together with references in a paper by Yoder (1950). Earlier it was shown in a paper by Greig and Barth (1938) that a dry melt of jadeite composition crystallizes to nepheline and albite, with a solidus at 1068° C. and a nepheline liquidus at 1138°. It was further shown that a natural jadeite from Burma (U.S.N.M. no. 94303) began to melt metastably as low as 800° and yielded nepheline and melt at 1015°, with the conclusion that jadeite was unstable under the conditions of the experiment. Schairer and Merwin (unpublished, 1948) showed that the melt crystallizes into albite and nepheline with a liquidus at 1128° C. (Yoder, 1950, p. 319).

Jadeite could conceivably be formed by the following solid-state reactions:

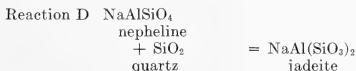
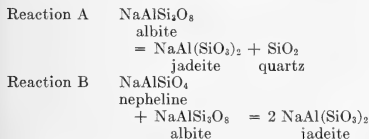

In all three of these reactions, advance from left to right, as written, would proceed with a decrease in volume, and hence would be favored by increase of pressure. However, experiments at pressures up to 3,000 bars were not successful in producing jadeite. It will be shown below that reaction A tends to proceed in the reverse direction, from right to left, at ordinary temperature and pressure, but becomes favored in the forward direction (left to right) by the application of high pressure, while reactions B and D tend to advance from left to right at all pressures at 25° C. in the direction of producing jadeite. Deductions based on reaction B have led to establishing in the minds of petrologists the hypothesis that jadeite is a mineral formed under high pressures without the adequate realization that (a) even in a highly favorable case the application of high pressure produces only a relatively small contribution to the affinity of the process, as measured by the decrease in the free energy for the reaction; and (b) although the progress of a reaction may be favored by a decrease in the free energy, the advance may be hampered by the existence of passive resistances to change, more specifically, of high energy barriers (insufficient energies of activation) to such an extent that no advance may be possible. Such factors especially play a large role in reactions of silicates, as is well known. The influence of the kinetic factors mentioned has been clearly discussed in a recent text on petrology (Turner and Verhoogen,

<sup>1</sup> Visiting investigator of the Carnegie Institution of Washington associated with the staff of the Geophysical Laboratory. Member of staff of the Geological Survey of Finland. Present address, Department of Geology, University of Helsinki, Helsinki, Finland.

1951) to which reference may be made for the literature on the subject.

The above observations make clear the existence of a need for a thermodynamic study of reactions by which jadeite could be formed. It is the purpose of this paper to present the results of a study leading to the evaluation of the free energy changes for the reactions mentioned, A, B, and D, as well as for a fourth reaction C

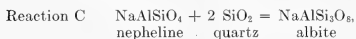

with the aim of establishing the possibility of the formation of jadeite in the absence of passive resistances to change, under the standard thermochemical conditions of 25°C. and atmospheric pressure. Included are considerations dealing with the influence of high pressure on the free energy changes, foundations for which were laid by the measurements of Yoder and Weir (1951), who, however, considered the effect of pressure on the formation of jadeite solely by reaction B.

The four reactions are interrelated as follows:



These interrelations will be considered in some detail in a later section. It is appropriate to mention that the discussions of the four reactions are confined throughout to the solid phase reactions, wherein the passive resistances to change play a preponderant role. It is well known that no difficulties arise in the preparation of homogeneous melts of the composition of any of constituents of these reactions nor in the mixing of such melts to produce melts of intermediate composition. Difficulties are, however, encountered in the crystallization of such melts to produce the crystalline compounds, not only in the case of jadeite, as indicated, but with albite and quartz as well. The high energy barriers which are effective in delaying the crystallization of the melts are compounded in solid-phase reactions, and hence it is plausible to expect that the rate of reaction in such systems as are here considered would be exceptionally low.

#### OUTLINE OF THE THERMODYNAMIC TREATMENT

For reactions at constant temperature and pressure, combination of the first and second laws of thermodynamics yields as the fundamental criterion for equilibrium in a chemical reaction the condition that a function of state of the system called the free energy,  $F$ , in the nomenclature of Lewis and Randall (1923), be at a minimum. According to the adopted conventions a reaction not at equilibrium may tend to advance toward equilibrium with a decrease in the free energy.

The quantity  $F$  is defined as

$$F = E + PV - TS = H - TS \quad (1)$$

where  $E$  is the internal energy,  $V$  the volume,  $S$  the entropy, and  $P$  and  $T$  the absolute pressure and temperature, respectively. The quantity  $H$ , called the heat content or enthalpy, is also a function of state of the system, like  $F$ ,  $E$ , and  $S$ . Other definitions of  $F$  are employed for chemical systems to relate changes in  $F$  to the equilibrium constant of a reaction, or to the electromotive force of a galvanic cell in which the reaction may occur. For the present discussion other such definitions are not found to be suitable.

At constant temperature and pressure, the change in the standard free energy of a reaction, i.e.,  $\Delta F^\circ$ , for a reaction in which all the constituents are in their standard states (Rossini, 1951), is given by

$$\Delta F^\circ = \Delta H^\circ - T\Delta S^\circ \quad (2)$$

where  $\Delta$  signifies a finite increment in the value of the quantity to which it is applied. According to (2),  $\Delta F^\circ$  may be evaluated from the separate measurements of  $\Delta H^\circ$  and  $\Delta S^\circ$ .

$\Delta H^\circ$  represents the quantity of heat which would be absorbed per mole of reaction if the reaction occurred at constant temperature and pressure in a calorimeter. Since none of the reactions considered will advance at an appreciable rate, a resort is made to dissolving each of the reaction constituents in a suitable common solvent, which in this case is hydrofluoric acid of 20.0 percent

strength, and measuring the heat of reaction for each of the solution reactions.  $\Delta H^\circ$  is then determined by a conventional combination of the separate thermochemical processes in accordance with the law of Hess.

The entropy change  $\Delta S^\circ$  is evaluated through application of the third law of thermodynamics to the low temperature heat capacities measured for each of the reaction constituents. The methods of evaluation are outlined by Kelley (1950).

#### THE CALORIMETER AND METHODS OF MEASUREMENT

A solution calorimeter designed for use at temperatures near  $75^\circ\text{C}$ . with hydrofluoric and other strong acids has been described by Torgeson and Sahama (1948). The calorimeter used in this investigation is of similar construction except for certain details. It is shown in Fig. 1, and a preliminary description of it with photographs of the parts has been given by Adams (1947, 1948, 1949). The calorimetric assembly is immersed in oil in a thermostatic bath to the level indicated at UU. The thermostatic bath is held at a temperature near  $75^\circ\text{C}$ . with a sensitivity of ca.  $+0.02^\circ$ . It is controlled by a "metastatic" mercury thermostat; the exact value of the mean bath temperature depends on the setting of the particular thermostat in use at any given time. During the course of this study the mean temperature of the bath was  $74.7^\circ$ .

The gold calorimeter vessel K of about 900 ml capacity is filled with 760 ml of 20.0 percent (by weight) reagent grade hydrofluoric acid, which is obtained by dilution of 48 per cent acid as received from the supplier in plastic bottles. All the acid used in the measurements reported here came from the same lot and was analyzed from time to time by titration with standard NaOH. The calorimeter vessel has four chimneys in its cover, one of which serves for dropping in samples through a bakelite tube, not shown in the diagram, and the other three for holding the stirrer CL and the resistance thermometer and calibrating heater, M and N, contained in the protecting gold wells F and G.

The resistance thermometer and the calibrating heater M and N are wound on thin-

walled, hollow copper spools, which fit their protecting wells F and G very closely. Good thermal contact is secured by filling the intervening annular space with vacuum pump oil. One advantage of separate locations for the two coils is that the temperature of the calorimeter may be observed while the calibrating current is turned on.

The resistance thermometer is a coil of enameled and single silk-covered B. & S. gauge no. 40 copper wire. The calibrating heater is wound of double silk-covered B. & S. gauge no. 35 manganin wire. Both coils are adjusted to have resistances of ca. 100 ohms at the operating temperature. The calorimeter stirrer housing is made of Teflon;

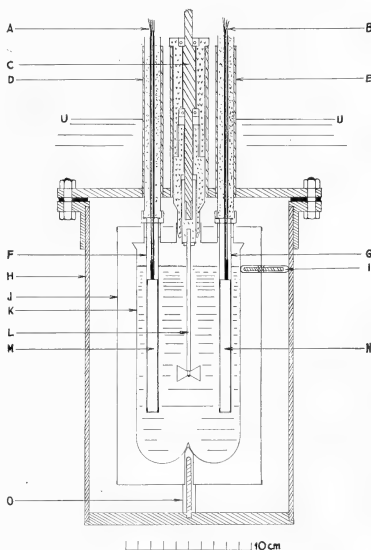

Fig. 1.—A solution calorimeter for use with hydrofluoric acid. A, B, leads from the resistance thermometer and calibrating heater; C, stirrer assembly; D, E, chimneys in the cover of the calorimeter jacket; F, G, protecting gold wells for the measuring instruments; H, calorimeter jacket; I, centering supports (three) for the calorimeter and radiation shield; J, radiation shield; K, gold calorimeter vessel; L, stirrer propeller shaft; M, N, resistance thermometer and calibrating heater; U, U, level of immersion in thermostat bath filled with oil; O, insulating support for calorimeter and shield.

shaft C rotates on two ball bearings as indicated and supports at its lower end the platinum propeller L by means of a Teflon coupling, which serves to block heat conduction.

Measurements with the resistance thermometer are made by means of a constant current "fixed arm" Wheatstone bridge circuit connected to a potentiometer for measuring the e.m.f. unbalance of the bridge. The bridge has two very nearly equal ratio arms of 2000 ohms each and a third arm adjustable in steps of 0.1 ohm; the thermometer is connected as the fourth arm with current and compensating leads. An accurate plug-type resistance box, made by Otto Wolff, Berlin, was used for the bridge arms. Provision is made in the connections for observations in either the N or R position, according to the code of the Mueller resistance thermometer bridges. The current through the bridge is maintained at 0.004 amp. with a sensitivity approaching 0.001 per cent. In practice the adjustable arm is pre-set at a resistance of ca. 0.3 ohms lower than the resistance of the thermometer at the temperature at which the cooling rate of the calorimeter is zero. This is done in order that the e.m.f. unbalance of the bridge be always positive in a selected direction, and that it be reasonably small (usually less than 1000  $\mu\text{V}$  [ $\mu\text{V}$  = microvolts]). Unbalanced e.m.f.'s of this order of magnitude are calculated to be a linear function of the temperature difference to within 2 parts in 100,000, which is quite adequate since the calorimetric rises in the solution experiments have been usually less than 500  $\mu\text{V}$ . With a particular thermometer coil 1° temperature difference corresponded to 634  $\mu\text{V}$  in the bridge-unbalance e.m.f.

The electrical energy for calibration is supplied to the calorimeter at a rate which is comparable with the rate of generation of heat by the dissolving samples. The calibrating current is determined by measuring the potential drop across the terminals of a 0.1 ohm standard resistor in a circuit arrangement recommended by White (1910). In our set-up this involves shunting the heater coil by a series combination of a 10-ohm standard resistor and an accurate resistance box of 10,000-ohm range adjustable in steps of

0.1 ohm. By means of this circuit a known fraction of the potential drop through the heater may be measured, and thereby the resistance of the heater determined at the calorimeter temperature while the heater is carrying current. Energy input times in calibration were measured by reference to the time-signal clock of this Laboratory, with the energizing switch operated manually. A calibration is performed before or after each heat of solution experiment.

A White double potentiometer of 100,000  $\mu\text{V}$  range is used for the potential measurements. This is carefully shielded against electrical leakage, which would produce significant errors in the measurements. The potentiometer is calibrated in international units, and is frequently standardized against a calibrated standard cell in terms of int. volts. We have for this reason retained the use of the international units in all the measurements and express the results in terms of the defined thermochemical calorie, 1 cal. = 4.1833 int. joules.

The samples to be dissolved in the calorimeter are contained in gelatine capsules (size 000), weighted down for rapid immersion in the acid by a platinum weight attached to the outside by means of a platinum wire hook. The capsules after weighing are kept at room temperature in a metal-lined box provided with a sensitive thermometer. Weights of the samples are corrected to weight in vacuum. The heats of reaction are adjusted to correspond to the process

Reactants (state specified, 25°)  
→ Products (state, 74.7°),

by applying corrections to the observed heat of reaction per capsule and contents (a) for the heating up of the platinum sinkers from room temperature to 74.7°, (b) for the departure of the capsule and contents from 25°, and (c) for the heat of the process

Gelatine (amorph., 25°)  
→ Gelatine (HF soln., 74.7°).

The heat capacity of platinum is taken as  $c_p = 0.032$  cal/g and that of gelatine as 0.5 cal/g. The heat of reaction of gelatine in the above process was measured and found to be  $\Delta H = 22.2 \pm 0.4$  cal/g. The purpose of these corrections is to obtain heats of



reaction which by the addition of thermochemical equations will yield values for combination reactions at the conventional thermochemical reference temperature of 25° C.

The measurements of the calorimeter temperature were corrected for heat exchange with the surroundings by a procedure based on Newton's law.

Corrections for the impurities in the samples were applied as demanded by the indications of the analyses. In preparation for making corrections for plus water (water not driven off at 110°) measurements were made of the process

Water (l., 25°) → Water (HF soln., 74.7°);  
 $\Delta H = 788 \pm 5$  cal/mole

and 1438 cal/mole added for the heat of melting, to result in

Water (ice, 25°) → Water (HF soln., 74.7°);  
 $\Delta H = 2226$  cal/mole.

The ice correction was employed on the assumption that plus water is retained in the minerals as a solid.

#### THE MATERIALS

The materials used in this study are described below:

*Albite, Amelia, Va.* Supplied by the U. S. National Museum, no. 5390. This could be obtained of good purity by hand picking.

*Albite, Varuträsk, Sweden.* Supplied by Th. G. Sahama. This contained numerous inclusions which were separated after crushing by magnetic separation, flotation, and centrifugation in heavy liquids.

*Jadeite, Burma.* Supplied by the U. S. National Museum, no. 94829. A cylinder from the sample was used in compressibility measurements, Adams and Gibson (1929), Yoder and Weir (1951). H. E. Merwin found the material to be practically pure jadeite. Crushed rock was purified by flotation in heavy liquids by L. H. Adams for use in measurements of low temperature heat capacities and heats of solution.

*Jadeite, Japan.* Specimen from Kotaki, Japan. USNM no. 105860. This specimen contained liquid inclusions, analcite, tremolite, and albite. Crushed rock was purified by centrifugation in Clerici solution, followed by further separations in Clerici solution with high frequency low amplitude agitation.

*Quartz, Lisbon, Md.* Collected by C. N. Fenner and J. W. Greig. Crushed and treated with hydrochloric acid by General Chemical Co. Residue of 0.03 percent after evaporation with HF + H<sub>2</sub>SO<sub>4</sub>.

TABLE 1.—RESULTS OF CHEMICAL ANALYSES OF THE MATERIALS

Material	Albite Varuträsk	Albite Amelia	Jadeite Burma	Jadeite Japan	Nepheline Synthetic
Analyst*	Zies	Chad.	Zies	K.	B. M.
SiO <sub>2</sub> .....	68.76	67.84	59.51	58.96	42.42
TiO <sub>2</sub> .....	0.00	0.00	0.01	0.00	0.01†
Al <sub>2</sub> O <sub>3</sub> .....	19.50	19.65	24.31	24.10	35.92
Fe <sub>2</sub> O <sub>3</sub> .....	0.13	0.03	0.35	0.21	0.05†
FeO.....	n. d.	0.02	0.03	0.00	
MgO.....	0.00	0.04	0.58	0.82	0.05†
CaO.....	0.13	0.00	0.77	1.12	0.05†
Na <sub>2</sub> O.....	11.51	11.07	14.37	14.41	21.40
K <sub>2</sub> O.....	0.13	0.29	0.02	0.11	0.1†
H <sub>2</sub> O <sup>+</sup> .....	0.08	0.56	0.06	0.28	
H <sub>2</sub> O <sup>-</sup> .....	—	0.30	—	0.02	
Other.....	0.02 P <sub>2</sub> O <sub>5</sub>		0.01 MnO 0.01 Cr <sub>2</sub> O <sub>3</sub>		
Total.....	100.26	99.80	100.03	100.03	100.00

\* Names of analysts indicated by abbreviations:

Zies = E. G. Zies, Geophysical Laboratory

Chad. = E. Chadbourn, University of Minnesota

K. = Oleg von Knorring, University of Leeds

B. M. = Bureau of Mines, analysis furnished by K. K. Kelley

† Results of spectroscopic analysis in terms of the elements.

*Quartz, S.I.* Probable source, Sycamore Island in Potomac River. A bottle of this was furnished by E. S. Shepherd. Residue 0.06 percent after evaporation with  $\text{HF} + \text{H}_2\text{SO}_4$ .

*Nepheline, synthetic.* Prepared by J. F. Schairer.

Analyses of the purified materials are collected in Table 1.

The purified materials were prepared for dissolving in the solution calorimeter by grinding for about three hours in a power grinder, using either agate or mullite mortar and pestle. The resulting impalpable powder was then elutriated in distilled water, usually three times, with 10 minutes allowed for settling of the coarser particles. The finest fraction for use was then filtered off under suction on a heavy paper in a Buechner funnel and air dried before a final drying in an oven at  $120^\circ \text{C}$ . The elutriated powder tends to agglomerate into tiny fragile lumps. It was found that particularly jadeite and nepheline when elutriated tend not to dissolve smoothly in the calorimeter. In later experiments with unelutriated preparations it was found that these materials dissolved sufficiently rapidly for calorimetric determinations and, hence, elutriation was avoided. This helped to eliminate not only the uneven solution rates, but other troubles as well. Thus, in some of the early experiments, residual lumps of a material which may have been undissolved sample, but which were identified as chiolite,  $5\text{NaF} \cdot 3\text{AlF}_3$ , were found in the calorimeter. No such precipitates were found when unelutriated samples were used.

The molecular compositions of the materials were computed from the results of the analyses in the usual manner for the calculation of the norm, and the observed heats of solution corrected for the heats of solution of the small amounts of impurities found in the manner indicated by Torgeson and Sahama (1948).

#### MEASUREMENTS AND RESULTS

*The heats of reaction  $\Delta H^\circ_{298.16}$ .* The standard heats of reaction  $\Delta H^\circ_{298.16}$  for the four chemical reactions A to D are obtained as resultants of summations of the heats of reaction of the individual solution reactions presented in skeleton form in Table 2. Con-

ventionally, they represent heats of the formation reaction of the products on the right from the reactants on the left of the reaction as written. Thus, for reaction B,  $\Delta H^\circ_{298.16}$  represents the heat of formation of two moles of jadeite from one mole of nepheline plus one mole of albite, the heats of formation of which are taken as zero. Heats of formation from the elements are derivable from these heat values by addition of the heats of formation of the reactants from the elements. Measurements are in progress which will permit such computations to be made.

The reader may be reminded that solution reactions are destruction reactions for the constituents dissolved and hence that, in order to evaluate heats of formation of reactions A to D as indicated in the second part of Table 2, the summations must be performed as there outlined; that is, by subtracting the sum of the heats of solution of the products on the right from the sum of those of the reactants on the left of the chemical equation as written. For other examples, see Torgeson and Sahama (1948) and King (1951).

The uncertainties are stated in terms of the standard deviation according to the recommendations of Rossini and Deming (1939). Attention may be directed to the two values given for the heat of solution of Japanese jadeite. These represent values for the material ground in agate in the one case, and ground in mullite in the other. A value for the average of the two is given with its consequent very great uncertainty. It is possible that the two individual values represent jadeite made impure by the grinding; however, the loss of weight of the mortars and pestles was not determinable, and no reasonable computation could be made to allow for the silica and mullite presumably introduced as impurities. Hence only the average value is used in the computations.

The heat of solution value obtained for S. I. quartz,  $-33,300 \pm 40$  cal/mole in 20.0 percent HF acid at  $74.7^\circ$ , may be compared with values for quartz obtained recently by others. Torgeson and Sahama (1948) obtained  $-33,000 \pm 20$  cal/mole in 20.1 percent HF acid at  $73.7^\circ$ ; King (1951) got  $-33,290 \pm 80$  at  $73.7^\circ$  and  $-32,810 \pm 90$  at  $50^\circ$  in 20.1 percent HF acid; and Sahama

and Neuvonen (1951),  $-33,240 \pm 50$  in 20.1 percent acid at  $75.1^\circ$ . Our value for quartz, Lisbon, Md., is  $-33,130 \pm 30$  cal/mole in 20.0 percent acid at  $74.7^\circ$ . The difference in the values for the Lisbon and the S. I. quartz is apparently a characteristic of the substances, just as differences are found for the two albites and the two jadeites, all after correction for impurities.

The individual heat of reaction values,  $\Delta H^\circ_{298.16}$ , for the four reactions A to D, obtained by combinations of the thermochemical equations (1) to (4) of Table 2, are given in the first column of Table 4.

*The entropies.*—The values of the entropies  $S^\circ_{298.16}$  of the four materials for this problem were determined from measurements of the low temperature heat capacities at the Pacific Station of the Bureau of Mines by Kelley and Todd, who will publish the detailed measurements. We are permitted to

use the results through the courtesy of Dr. Kelley. The data and their resultants for the reactions A to D are given in Table 3.

*The free energy changes.*—Combinations of the heat of reaction values  $\Delta H^\circ_{298.16}$  with the corresponding  $-T\Delta S^\circ_{298.16}$  values from Tables 3 and 4 according to the thermodynamic relation (2) yield the values of the free energy changes  $\Delta F^\circ_{298.16}$  for the reactions A to D as given in the last column of Table 4. Because of the smallness of the resultant heats of reaction for all of the reactions in question and the rapid accumulation of thermochemical errors, the uncertainty is in some cases greater than the net value of the heat of reaction  $\Delta H^\circ_{298.16}$ . Nevertheless, it appears clear that within the relatively large error the combinations of the heat and entropy terms result in free energy decreases for reactions B, C, and D, and in an increase for reaction A. The re-

TABLE 2.—HEATS OF REACTION OF THE MATERIALS STUDIED

Reaction	$\Delta H$	kcal/mole Uncertainty
(1) $\text{NaAlSi}_3\text{O}_8$ (c, $25^\circ$ ) + $22\text{HF}$ (soln., $74.7^\circ$ ) $\rightarrow$ $\text{NaF}$ (soln., $74.7^\circ$ ) Albite + $\text{AlF}_3$ (soln., $74.7^\circ$ ) + $3\text{H}_2\text{SiF}_6$ (soln., $74.7^\circ$ ) + $8\text{H}_2\text{O}$ (soln., $74.7^\circ$ )	Amelia Varu.	-149.79 0.11 -148.12 0.21
(2) $\text{NaAlSiO}_4$ (c, $25^\circ$ ) + $10\text{HF}$ (soln., $74.7^\circ$ ) = $\text{NaF}$ (soln., $74.7^\circ$ ) + $\text{AlF}_3$ (soln., $74.7^\circ$ ) Nepheline + $\text{H}_2\text{SiF}_6$ (soln., $74.7^\circ$ ) + $4\text{H}_2\text{O}$ (soln., $74.7^\circ$ )	synthetic	- 87.33 0.21
(3) $\text{NaAl}(\text{SiO}_3)_2$ (c, $25^\circ$ ) + $16\text{HF}$ (soln., $74.7^\circ$ ) = $\text{NaF}$ (soln., $74.7^\circ$ ) Jadeite + $\text{AlF}_3$ (soln., $74.7^\circ$ ) + $2\text{H}_2\text{SiF}_6$ (soln., $74.7^\circ$ ) + $6\text{H}_2\text{O}$ (soln., $74.7^\circ$ )	Burma Japan, ground in agate Japan, ground in mullite Japan, av.	-114.96 0.35 -114.35 0.09 -115.93 0.17 -115.14 0.79
(4) $\text{SiO}_2$ (c, $25^\circ$ ) + $6\text{HF}$ (soln., $74.7^\circ$ ) = $\text{H}_2\text{SiF}_6$ (soln., $74.7^\circ$ ) Quartz + $2\text{H}_2\text{O}$ (soln., $74.7^\circ$ )	Lisbon, Md. S.I.	-33.130 0.030 - 33.300 0.040
Reaction A $\text{NaAlSi}_3\text{O}_8$ (c, $25^\circ$ ) = $\text{SiO}_2$ (c, $25^\circ$ ) + $\text{NaAl}(\text{SiO}_3)_2$ (c, $25^\circ$ ) Albite quartz jadeite $\Delta H_A = \Delta H_1 - \Delta H_3 - \Delta H_4$		
Reaction B $\text{NaAlSi}_2\text{O}_7$ (c, $25^\circ$ ) + $\text{NaAlSiO}_4$ (c, $25^\circ$ ) = $2\text{NaAl}(\text{SiO}_3)_2$ (c, $25^\circ$ ) Albite nepheline jadeite $\Delta H_B = \Delta H_1 + \Delta H_2 - 2\Delta H_3$		
Reaction C $\text{NaAlSiO}_4$ (c, $25^\circ$ ) + $2\text{SiO}_2$ (c, $25^\circ$ ) = $\text{NaAlSi}_3\text{O}_8$ (c, $25^\circ$ ) Nepheline quartz albite $\Delta H_C = \Delta H_2 + 2\Delta H_4 - \Delta H_1$		
Reaction D $\text{NaAlSiO}_4$ (c, $25^\circ$ ) + $\text{SiO}_2$ (c, $25^\circ$ ) = $\text{NaAl}(\text{SiO}_3)_2$ (c, $25^\circ$ ) Nepheline quartz jadeite $\Delta H_D = \Delta H_2 + \Delta H_4 - \Delta H_3$		

TABLE 3.—ENTROPIES

Data supplied by K. K. Kelley

Material	$S^{\circ}_{298.16}$	eu/mole
NaAlSi <sub>3</sub> O <sub>8</sub> (albite, Varuträsk)	49.2	±0.3
NaAlSi <sub>3</sub> O <sub>8</sub> (nepheline, synthetic)	29.1	±0.2
NaAl(SiO <sub>3</sub> ) <sub>2</sub> (jadeite, Burma)	31.8	±0.2
SiO <sub>2</sub> (quartz)	10.0	0.1
Reaction	$\Delta S^{\circ}_{298.16}$	
A. NaAlSi <sub>3</sub> O <sub>8</sub> = NaAl(SiO <sub>3</sub> ) <sub>2</sub> + SiO <sub>2</sub>	-7.4	±0.4
B. NaAlSiO <sub>4</sub> + NaAlSi <sub>2</sub> O <sub>6</sub> = 2NaAl(SiO <sub>3</sub> ) <sub>2</sub>	-14.7	±0.5
C. NaAlSiO <sub>4</sub> + 2SiO <sub>2</sub> = NaAlSi <sub>2</sub> O <sub>6</sub>	0.1	±0.4
D. NaAlSiO <sub>4</sub> + SiO <sub>2</sub> = NaAl(SiO <sub>3</sub> ) <sub>2</sub>	-7.3	±0.3

sults signify that in the absence of passive resistances to change, reactions B, C, and D would advance as written, from left to right, whereas reaction A would advance in the opposite direction, from right to left, and would result in combining jadeite and quartz to form albite.

The decrease in free energy for reaction C is in good accord with petrological deduction from systems studied at higher temperatures, and also with field evidence in nature, where nepheline and quartz appear not to be found in intimate association.

INFLUENCE OF PRESSURE ON  $\Delta F$ 

For an isothermal reaction the influence of a change in pressure on the change in the free energy of reaction is given by

$$d\Delta F_T = \Delta V dP_T \quad (3)$$

where the subscript  $T$  denotes constancy of temperature. The equation (3) can be integrated if the volumes of the reaction constituents are known as functions of pressure. For reaction B the data on jadeite, nepheline, and albite have been secured and evaluated by Yoder and Weir (1951) who included in their discussion the effect of thermal expansion in addition to that of compressibility. For the other three reactions, A, C, and D, discussed in this paper, there are needed, in addition, data for quartz, which are already available in the literature. The density of quartz at 25° may be taken as 2.647 g/cm<sup>3</sup> from the work of Johnston and Adams (1912). From the data on the compressibility of quartz the volume compression at 20°,  $\Delta V/V_0 = -2.70 \times 10^{-6}P + 20.4 \times 10^{-12}P^2$  as evaluated by Birch (1942) for pressure  $P$  in bars

from the measurements of Adams and Williamson (1923). Accordingly,  $V_{25^\circ} = 22.69$  cm<sup>3</sup>/mole and the molar volume at 25° and the pressure  $P$  bars is  $V_P = 22.69 - 0.613 \times 10^{-4}P + 0.463 \times 10^{-9}P^2$  cm<sup>3</sup>/mole. From this datum and the data of Yoder and Weir for jadeite, nepheline, and albite, converted to express  $P$  in bars instead of atm, we obtain the following volume changes for reactions A, B, C, and D:

$$\Delta V_A = -17.28 + 1.083 \times 10^{-4}P - 1.90 \times 10^{-9}P^2 \quad (4)$$

$$\Delta V_B = -33.66 + 2.369 \times 10^{-4}P - 2.78 \times 10^{-9}P^2 \quad (5)$$

$$\Delta V_C = +0.90 + 0.200 \times 10^{-4}P + 1.01 \times 10^{-9}P^2 \quad (6)$$

$$\Delta V_D = -16.38 + 1.283 \times 10^{-4}P - 0.88 \times 10^{-9}P^2 \quad (7)$$

and the corresponding free energy changes in thermochemical calories at 25° and at the pressure  $P$  in bars:

$$\Delta F_A = \Delta F_{0A} - 0.4130P + 1.294 \times 10^{-6}P^2 - 15.1 \times 10^{-12}P^3 \quad (8)$$

$$\Delta F_B = \Delta F_{0B} - 0.8045P + 2.83 \times 10^{-6}P^2 - 22.2 \times 10^{-12}P^3 \quad (9)$$

$$\Delta F_C = \Delta F_{0C} + 0.0215P + 0.239 \times 10^{-6}P^2 + 8.1 \times 10^{-12}P^3 \quad (10)$$

$$\Delta F_D = \Delta F_{0D} - 0.3915P + 1.53 \times 10^{-6}P^2 - 7.0 \times 10^{-12}P^3 \quad (11)$$

where the  $\Delta F_0$  terms, the constants of integration, are the free energy changes  $\Delta F^{\circ}_{298.16}$  at the pressure of 1 atm (effectively zero pressure in considering effects of high pressures) given in the last column of Table 4 for the different reactions.

It will be noted that the  $\Delta F$  for reactions B and D, already negative at 1 atm, will become more negative with the application of high pressures. Reaction C, which is not directly concerned with the stability relations of jadeite, is of interest in that its  $\Delta F_C$  is almost uninfluenced by pressure. For reaction A,  $\Delta F_A$ , which is positive at 1 atm, becomes negative at pressures ranging from ca. 1600 to ca. 6000 bars, depending upon the value chosen at 1 atm. This suggests the possibility that Japanese jadeite, often found in association with quartz, may have been formed at depth, but does not agree with field evidence, according to which Japanese jadeite may be a hydrothermal product, in which case depth is not critical (Yoder, 1951, personal communication).

INFLUENCE OF TEMPERATURE ON  $\Delta F$ 

For an isobaric process the influence of a change in temperature on the change in the free energy for a reaction is given by

$$d(\Delta F_P/T) = -(\Delta H/T^2)dT_P \quad (12)$$

where the subscript  $P$  denotes constant pressure. The equation (12) can be integrated if the heat contents of the reaction constituents are known at different temperatures. For the reactions studied here only data on albite and quartz are available (Kelley, 1949) and hence the evaluation of the  $\Delta F$ 's as

functions of temperature can not yet be made. It is planned to make the needed measurements on jadeite and nepheline in the near future.

## DISCUSSION

The data presented in this paper lead to the conclusion that under favorable kinetic conditions—that is, in the absence of passive resistances to change—jadeite could be formed at 25° C. and atmospheric pressure by either reaction B or D. In nature, an exact ratio of the reactants such as is de-

TABLE 4.—MOLAL HEATS OF REACTION, ENTROPY, AND FREE ENERGY CHANGES\*

$$\Delta F^\circ_{298.16} = \Delta H^\circ_{298.16} - 298.16 \Delta S^\circ_{298.16}$$

Ab = Jd + Qu			kcal/reaction		
Ab	Jd	Qu	$\Delta H^\circ_{298.16}$	$-T\Delta S^\circ_{298.16}$	$\Delta F^\circ_{298.16}$
Var	Bu	S.I.	0.14 ± 0.41	2.21 ± 0.11	2.35 ± 0.42
Var	Jp av	S.I.	0.32 ± 0.83	2.21 ± 0.11	2.53 ± 0.83
Am	Bu	S.I.	-1.53 ± 0.37	2.21 ± 0.11	0.68 ± 0.39
Am	Jp av	S.I.	-1.35 ± 0.81	2.21 ± 0.11	0.86 ± 0.81

Ab + Ne = 2Jd					
Ab	Ne	Jd			
Var	synth	Bu	-5.53 ± 0.43	4.38 ± 0.15	-1.15 ± 0.45
Var	synth	Jp av	-5.17 ± 1.61	4.38 ± 0.15	-0.79 ± 1.62
Am	synth	Bu	-7.20 ± 0.41	4.38 ± 0.15	-2.82 ± 0.43
Am	synth	Jp av	-6.84 ± 1.60	4.38 ± 0.15	-2.46 ± 1.62

Ne + 2Qu = Ab					
Ne	Qu	Ab			
synth	S.I.	Var	-5.81 ± 0.30	-0.03 ± 0.15	-5.84 ± 0.34
synth	S.I.	Am	-4.14 ± 0.24	-0.03 ± 0.15	-4.17 ± 0.29

Ne + Qu = Jd					
Ne	Qu	Jd			
synth	S.I.	Bu	-5.67 ± 0.41	2.18 ± 0.09	-3.49 ± 0.41
synth	S.I.	Jp av	-5.49 ± 0.82	2.18 ± 0.09	-3.31 ± 0.82

\* Abbreviations used:

Ab Am = Albite, Amelia, Va.

Var = Albite, Varuträsk, Sweden

Jd Bu = Jadeite, Burma

Jp av = Jadeite, Japan, average value

Ne synth = Nepheline, synthetic

Qu S.I. = Quartz, S.I.

manded by D would not likely obtain, and it may be instructive to consider a more detailed analysis of the possibilities. The free energy decreases for the three reactions B, C, and D range in the order  $-\Delta F_C > -\Delta F_D > -\Delta F_B$  according to Table 4. Therefore, in the absence of passive resistances to change, reaction C would occur first in a reaction mixture of nepheline and quartz. This reaction would continue until one of the reactants was used up. If nepheline were exhausted first, the reaction would stop with albite and unused quartz remaining behind. The only possibility for further reaction now would be reaction A, but since  $\Delta F_A$  is positive at 25° and 1 atm, no further reaction would occur at atmospheric pressure. If, on the other hand, quartz were exhausted first, reaction C would come to a stop with albite and the unused nepheline remaining behind, and this mixture would react by reaction B to produce jadeite until finally the nepheline or albite was exhausted. At the end the residue would contain jadeite and albite or quartz, or jadeite and nepheline, depending upon whether the original molar ratio of quartz to nepheline was greater than 1 or less than 1, respectively. These reactions as outlined would go in the sequence: C followed by B. If for some reason reaction C were hindered, but not reaction D, the product of reaction D would be jadeite and unused quartz for any molar ratio of quartz to nepheline in excess of 1, and jadeite with unused nepheline for a ratio of less than 1.

In the case of both reaction B and D, the tendency to form jadeite would be increased by the application of high pressure, the corresponding changes in the free energy being represented by equations (9) and (11). High pressure, likewise, would favor the advance of reaction A from left to right, according to equation (8). For this reaction  $\Delta F_A$  is positive at 25° and 1 atm, and changes sign to become negative at pressures of ca. 1,600 bars to ca. 6,000 bars, depending upon the particular materials which are reacting. At pressures higher than these a tendency would accordingly exist to dissociate albite and to form jadeite and quartz. Because of the interrelations among the four reactions in question, reaction A could not occur at any pressure in the presence of nepheline in the reaction mixture. It will be noted from equa-

tions (8), (9), and (11) that even in the most favorable case, that of reaction B, pressure produces only a small change in the free energy of the reaction, in this case the change being roughly  $-0.8$  kcal/mole per 1000 bars. As was mentioned previously, reaction C is almost uninfluenced by pressure, the small effect, as represented by equation (10) being to favor the reverse reaction.

The reactions investigated in this study present an unusually severe test of thermochemical data in that the net heats of reaction and the corresponding free energy changes are small numbers, values of which in many instances are comparable with the accumulated errors of the summations of the heats of solution from which they are derived.

The net result of this study may be summarized in the statement that the formation of jadeite is thermodynamically feasible at 25° C. without the application of pressure. While it is true that pressure favors the process, its effect in any case is relatively small. The failure to produce jadeite in the laboratory cannot accordingly be ascribed to unfavorable energy relations, but must be due rather to non-thermodynamic factors, such as we have loosely termed passive resistances to change, and the problem of synthesis of jadeite becomes again essentially a problem in reaction kinetics of the solid state.

#### ACKNOWLEDGEMENTS

The writers wish to acknowledge the support and encouragement which Dr. L. H. Adams, director of the Geophysical Laboratory, has given to this work, and the kind cooperation of Dr. K. K. Kelley and Dr. S. S. Todd, both of the Pacific Station of the Bureau of Mines, especially their permission to quote the entropy values given in this paper. They also wish to thank Dr. J. F. Schairer for preparing the sample of synthetic nepheline in sufficiently large quantity to be used in low temperature heat capacity work as well as for the heats of solution reported here; Dr. H. S. Yoder, especially for critically reading the paper, and for his pertinent and helpful comments; I. Michael, formerly of this Laboratory, for making some of the measurements; Dr. Th. G. Sahama, of

the University of Helsinki, for help in assembling and purifying some of the materials; and M. R. Vollmer, instrument maker, for his careful construction of the various parts of the calorimetric apparatus.

## REFERENCES

- ADAMS, L. H. *Annual report of the director of the Geophysical Laboratory*. Carnegie Inst. Washington Yearbook **47**: 27; **48**: 29; **49**: 27. 1947, 1948, 1949.
- and GIBSON, R. E. *The elastic properties of certain basic rocks and of their constituent minerals*. Proc. Nat. Acad. Sci. **15**: 713-724. 1929.
- and WILLIAMSON, E. D. *The compressibility of minerals and rocks at high pressures*. Journ. Franklin Inst. **195**: 475-529. 1923.
- BIRCH, F. *Handbook of physical constants*. Spec. Pap. Geol. Soc. Amer. **36**: 55. 1942.
- GREIG, J. W., and BARTH, T. F. W. *The system  $\text{Na}_2\text{O} \cdot \text{Al}_2\text{O}_3 \cdot 2\text{SiO}_2$  (nephelinite, carnegieite) —  $\text{Na}_2\text{O} \cdot \text{Al}_2\text{O}_3 \cdot 6\text{SiO}_2$  (albite)*. Amer. Jour. Sci. **35-A**: 93-112. 1938.
- JOHNSTON, J., and ADAMS, L. H. *On the density of solid substances with special reference to permanent changes produced by high pressures*. Journ. Amer. Chem. Soc. **34**: 563-584. 1912.
- KELLEY, K. K.: *Contributions to the data on theoretical metallurgy. X. High temperature heat content, heat capacity and entropy data for inorganic compounds*. Bur. Mines Bull. 476. 1949.
- . *Contributions to the data on theoretical metallurgy. XI. Entropies of inorganic substances*. Bur. Mines Bull. 477. 1950.
- KING, E. G.: *Heats of formation of crystalline calcium orthosilicate, tricalcium silicate and zinc orthosilicate*. Journ. Amer. Chem. Soc. **73**: 656-658. 1951.
- LEWIS, G. N., and RANDALL, M. *Thermodynamics and the free energy of chemical substances*. New York, 1923.
- ROSSINI, F. D. *Chemical thermodynamics*. New York, 1950. (Pp. 3, 249.)
- and DEMING, W. E. *The assignment of uncertainties to the data of chemistry and physics, with specific recommendations for thermochemistry*. Journ. Washington Acad. Sci. **29**: 416-440. 1939.
- SAHAMA, TH. G., NEUVONEN, K. J. Personal communication. 1951.
- TORGESON, D. R., and SAHAMA, TH. G. *A hydrofluoric acid solution calorimeter and the determination of the heats of formation of  $\text{Mg}_2\text{SiO}_4$ ,  $\text{MgSiO}_3$  and  $\text{CaSiO}_3$* . Journ. Amer. Chem. Soc. **70**: 2156-2160. 1948.
- TURNER, F. J., and VERHOOGEN, J. *Igneous and metamorphic petrology*. New York, 1951.
- WHITE, W. P. *A test of calorimetric accuracy*. Phys. Rev. **31**: 686-701.
- YODER, H. S. *The jadeite problem*. Amer. Journ. Sci. **248**: 225-248; 312-334. 1950.
- and WEIR, C. E. *Change of free energy with pressure of the reaction nepheline + albite = 2 jadeite*. Amer. Journ. Sci. **249**: 683-694. 1951.

ICHTHYOLOGY.—*Three new skates and a new chimaerid fish from the Gulf of Mexico*.<sup>1</sup> HENRY B. BIGELOW and WILLIAM C. SCHROEDER. (Communicated by Leonard P. Schultz.)

The U. S. Fish and Wildlife Service vessel *Oregon*, while engaged in a shrimp investigation in the Gulf of Mexico during the winter of 1950-51, caught a number of fishes that prove to be new to science. Stewart Springer, knowing of our interest in elasmobranchs and holocephalids, kindly sent us the specimens which we here describe. The holotypes and some of the paratypes are in the collection of the U. S. National Museum, while a representative of each species is in the collection of the Harvard Museum of Comparative Zoology.

*Raja lentiginosa*, n. sp.

*Study material*.—Male, 402 mm in total length, holotype, U. S. N. M. no. 153552, from the Campeche Bank, lat. 22° 32' N., long. 88° 47' W., in 29 fathoms, *Oregon* station 222; also four males

and three females from the latter region and from the northern part of the Gulf of Mexico, lat. 28° 10' to lat. 29° 11' N. and long. 85° 00' to 86° 52' W. in recorded depths of 85, 112, 165, and 305 fathoms, including *Oregon* stations 256, 257, 278, and 279.

*Distinctive characters*.—*Raja lentiginosa* closely resembles *R. garmani* but may be distinguished by the color pattern of its upper surface, which is densely freckled with very small dark, light-brown, and whitish spots (sparse in *garmani* and mostly grouped in a distinct rosette pattern).

*Description of holotype*.—Proportional dimensions in percent of total length:

Disc.—Extreme breadth 60.0; length 46.5.

Snout length.—In front of orbits 9.2; in front of mouth 11.2.

Orbits.—Horizontal diameter 4.2; distance between 2.9.

Spiracles.—Length 2.1; distance between 6.2.

Mouth.—Breadth 6.5.

<sup>1</sup> Contribution no. 555 from the Woods Hole Oceanographic Institution.

Exposed nostrils.—Distance between inner ends 6.0.

Gill openings.—Lengths, first 2.0; third 1.9; fifth 1.2; distance between inner ends, first 13.9; fifth 7.0.

First dorsal fin.—Vertical height 3.0; length of base 5.6.

Second dorsal fin.—Vertical height 3.0; length of base 5.5.

Pelvis.—Anterior margin 12.2.

Distance from tip of snout to center of cloaca 39.2; from center of cloaca to first dorsal 45.3; to tip of tail 60.8; from rear end of second dorsal base to tip of caudal 2.9.

Interspace between first and second dorsals 1.2.

Disc about 1.3 times as broad as long, maximum angle in front of spiracles about 120°; anterior margins weakly convex from just posterior to tip of snout to opposite orbits, thence gently concave between spiracles and outer corners which are broadly rounded; posterior margins and corners and inner margins all rounded. Axis of greatest breadth about 68 percent of distance back from tip of snout to axils of pectorals. Tail with a lateral fold, low down on each side, beginning abruptly posterior to axils of pelvis a distance about equal to space between spiracles and continuing almost to extreme tip, width of fold about the same throughout its length; length of tail from center of cloaca to origin of first dorsal fin 1.15 times as great and to its tip 1.54 times as great as distance from center of cloaca to tip of snout.

Five prominent thorns along anterior edge of orbit, one opposite inner central margin and three along posterior margin, the last opposite spiracle, with an additional thorn inward from this one; a row of thorns over margins of rostral process; prickles and very small thorns are present over anterior third of disc in advance of nuchal region and extend along outer margin rearward to about axils of pectorals; a triangular patch of about 17 thorns on shoulder region, five of which extend along median line from nuchal to scapular region; a naked area behind these for a distance about equal to distance between spiracles. A band of three to five rather regular rows of thorns along median zone of back and on tail beginning in advance of axils of pectorals a distance about equal to that from eye to snout and ending at origin of first dorsal, the lowermost row reaching nearly to tip of tail; the median row, counting from nuchal region, consisting of 33 thorns, in most cases alternating large and small; most all the thorns on tail with sharp points, directed backward; one

prominent thorn in space between dorsals; prickles on dorsal fins and caudal; skin over eye naked; a band of alar spines on outer part of each pectoral, in one to three rows, with 19 spines in longest row. Lower surface naked except for a small median patch of spines at extreme snout tip.

Snout in front of orbits 2.2 times as long as orbit, its length in front of mouth about 1.8 times as great as distance between exposed nostrils. Distance between orbits about 0.7 as great as length of orbit. Orbit twice as long as spiracle. Nasal curtain fringed; expanded posterior (outer) margins of nostrils fringed. Upper and lower jaws rather strongly arched centrally. Teeth  $\frac{5}{2}$  close set, mostly in straight rows rather than in quincunx, with small base, circular or oval, those in median sector of mouth with slender sharp cusp pointing toward symphysis or inward toward throat, those in outer sector with triangular cusp pointing toward corner of mouth, one row of teeth at symphysis in upper jaw, pointing straight downward. Distance between first gill openings 2.3 times as great as distance between exposed nostrils; between fifth openings 1.2 times; first gill openings 1.6 times as long as fifth and 0.3 as long as breadth of mouth. First and second dorsals similar in size and shape. Interspace between dorsals 0.22 as long as base of first dorsal. Caudal membrane from rear end of base of second dorsal about half as long as base of first dorsal. Pelvis deeply concave, strongly scalloped along anterior side of excavation but only weakly so rearward; anterior margin only 0.55 as long as distance from its own origin to rear tip of pelvic; anterior lobe slender, including four radial cartilages besides the first stout one; posterior lobe moderately convex along its forward half, thence nearly straight to its narrowly rounded tip, extending a little more than one-fifth the distance from axil of pelvis toward first dorsal; inner margin straight. Claspers reaching beyond tips of pelvis by a distance about equal to diameter of orbit.

Rostral cartilage firm, extending nearly to tip of snout. Anterior pectoral rays reaching about seven-tenths the distance from front of orbits toward tip of snout.

Color.—Upper surface everywhere sprinkled with very small light to dark brownish and whitish spots, including the tail, pelvis and claspers; many groups of about 30-50 dark spots scattered everywhere, the most prominent marking being the group of spots at axil of pectoral, some of the spots on tail grouped in form of bars, there being



about five prominent bars; light and dark spots present on anterior part of each dorsal fin and on caudal. Below whitish with a group of grayish

blotches, mostly fused, on each pectoral, and an elongate blotch along the inner part of the claspers anteriorly.

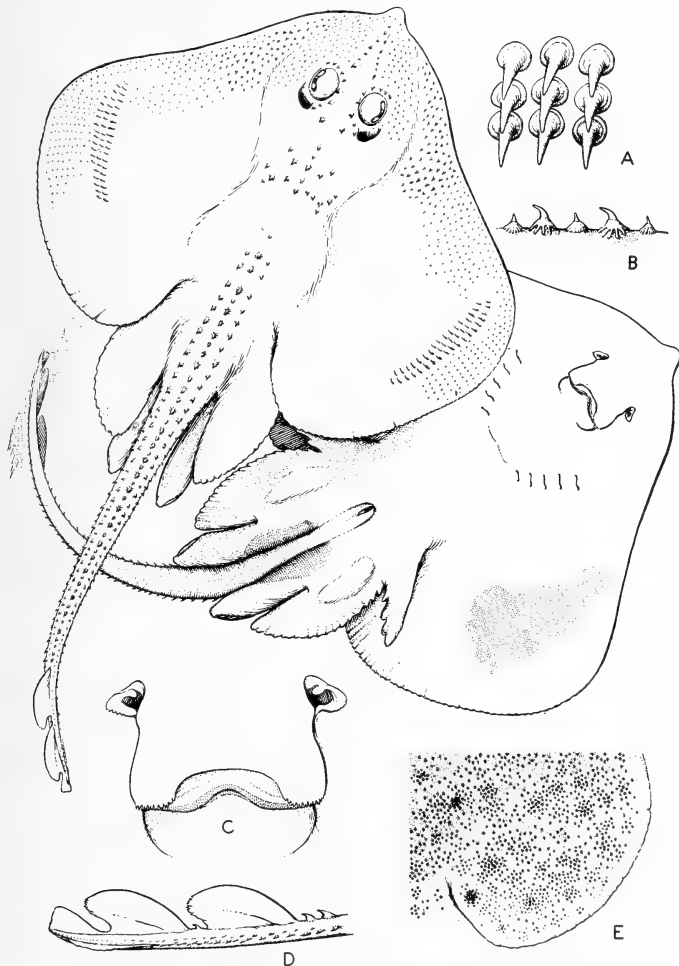

FIG. 1.—*Raja lentiginosa*, n.sp., male, 402 mm long, holotype (U.S.N.M. no. 153552): A, Upper teeth, about  $\times 10$ ; B, thorns on midrow of tail, about  $\times 2$ ; C, mouth and nostrils, about  $\times 1.5$ ; D, posterior part of tail, about  $\times 1$ ; E, section of upper surface to show color pattern.

A female 302 mm long differs slightly from the type by having no naked area on the midzone of back immediately behind shoulder region, but the thorns begin on the nape and extend without a break to the first dorsal, the rows being somewhat more irregular and the median row having about 45 thorns mostly of uniform size instead of alternating large and small. There is a patch of small thorns on the posterior part of the pectorals and a few on the pelvis and three thorns in the space between the dorsals. There are  $\frac{3}{4}$  teeth, in quincunx, with low triangular cusp, none of which point toward symphysis or corners of mouth.

On a male of 232 mm the claspers extend a little beyond the tips of the pelvis, while on a *R. garmani* of 285 mm they fail to reach the tips of the pelvis by a distance as great as diameter of orbit. This male has 46 teeth in upper jaw and lacks the small patch of thorns on the extreme tip of snout below.

The few specimens of this species thus far captured have been taken over a wide depth range, from 29 to 305 fathoms. It is known from the northern part of the Gulf of Mexico in the offings of Pensacola and Cape San Blas and in the southern part on Campeche Bank.

*Raja olseni*,<sup>2</sup> n. sp.

*Study material*.—Immature male, 280 mm in total length, holotype, U. S. N. M. no. 153556, from lat. 27° 25' N., long. 96° 13' W., 76 fathoms, Oregon station 157 and an immature male, 282 mm, paratype, M. C. Z. no. 37176, from lat. 27° 27' N., long. 96° 17' W., 65 fathoms, Oregon station 158.

*Distinctive characters*.—*Raja olseni* closely resembles *R. laevis* in general appearance and in lacking thorns along the midbelt of the disc from the level of the axils of the pectorals to the vicinity of the spiracles. But it differs from *laevis* in having an interspace between the dorsal fins nearly or quite as long as the base of the first dorsal (only 0.1 to 0.3 that long in *laevis*); by having a fringe on the expanded outer margin of the nostril (smooth in *laevis*); also the lateral folds along its tail reach to only opposite the anterior third of the caudal fin, but in *laevis* extend almost or quite to the extreme tip of the tail; the lower sides of the disc are prickly along the anterior edges and over the rostral

cartilage in *olseni* but smooth on *laevis* of equal size and its mucous pores are not marked with black as they are in *laevis*. It differs from *R. spinicauda* in its fringed nostril lobe, in its shorter tail folds, in the interspace between its dorsals, and in having three rows of thorns on the tail (only one row on *spinicauda*).

*Description of holotype*.—Proportional dimensions in percent of total length:

Disc.—Extreme breadth 69.0; length 54.0.

Snout length.—In front of orbits 15.6; in front of mouth 17.7.

Orbits.—Horizontal diameter 4.4; distance between 3.6.

Spiracles.—Length 2.0; distance between 6.3.

Mouth.—Breadth 7.9.

Exposed nostrils.—Distance between inner ends 7.9.

Gill openings.—Length, first 2.0; third 2.1; fifth 1.6; distance between inner ends, first 13.6; fifth 7.3.

First dorsal fin.—Vertical height 2.5; length of base 4.3.

Second dorsal fin.—Vertical height 2.4; length of base 4.6.

Pelvis.—Anterior margin 13.2.

Distance from tip of snout to center of cloaca 47.5; from center of cloaca to first dorsal 30.4; to tip of tail 52.5; from rear end of second dorsal base to tip of tail 3.2.

Interspace between first dorsal and second dorsal 4.3.

Disc about 1.3 times as broad as long, the maximum anterior angle in front of spiracles about 90°; anterior margins concave just posterior to tip of snout, weakly convex opposite eyes and spiracles, thence about straight rearward; outer corners narrowly rounded; posterior corners more broadly so; posterior margins gently convex. Axis of greatest breadth about 67 percent of distance back from tip of snout to axils of pectorals. Tail with a lateral fold, low down on each side, beginning posterior to axils of pelvis by a distance about four-fifths as long as eye and ending opposite anterior third of caudal fin, its length from center of cloaca to origin of first dorsal fin about 0.67 as great and to its tip about 1.1 times as great as distance from center of cloaca to tip of snout.

Two small thorns immediately in front of orbit, of which one is on the inner and one on the outer margin, also one on the inner rear margin; these are the only thorns or prickles on the disc. Sixteen thorns along midline of tail from a little in advance of axils of pelvis to first dorsal fin, and three in interspace between first and second dor-

<sup>2</sup> Named for Yngve H. Olsen in recognition of his excellent editorial work on Fishes of the Western North Atlantic.

sals. An additional row of thorns, widely and unevenly spaced, on each side of median row, beginning about opposite tips of pelvics and extending to opposite beginning of caudal fin; dorsals and caudal fin smooth. Lower surface with a narrow band of small prickles along anterior margin of disc from level of nostrils to tip of snout and also along rostral cartilage.

Snout in front of orbits 3.5 times as long as orbit, its length in front of mouth 2.2 times as great as distance between exposed nostrils. Distance between orbits 1.2 as great as length of

orbit. Orbit 2.2 times as long as spiracle. Nasal curtain fringed; expanded posterior (outer) margins of nostrils fringed. Upper and lower jaws moderately arched centrally. Teeth  $\overline{11}$ , close set in quincunx, ovate, with a triangular cusp. Distance between first gill openings 1.7 times as great as distance between exposed nostrils; between fifth gill openings 1.1 times; first gill openings 1.25 times as long as fifth and 0.25 as long as breadth of mouth. First and second dorsals similar in size and shape. Interspace between dorsals as long as base of first dorsal. Caudal



FIG. 2.—*Raja olseni*, n.sp., male, 280 mm long, holotype (U.S.N.M. no. 153556): A, Posterior part of tail, about  $\times 1.5$ ; B, mouth and nostrils, about  $\times 2$ ; C, upper teeth, about  $\times 12$ .

membrane from rear end of base of second dorsal about twice as long as base of first dorsal. Pelvics deeply concave, strongly scalloped along anterior side of excavation but only weakly so rearward; anterior margin about as long as distance from its own origin to rear tip of pelvic; anterior lobe moderately slender, including five radial cartilages besides the first stout one; posterior lobe moderately convex outwardly; rear tips abruptly rounded, extending about two-sevenths the distance from axil of pelvics toward first dorsal; inner margin straight. Claspers falling well short of tips of pelvics.

Rostral cartilage firm, extending to tip of snout. Anterior pectoral rays reaching about half way from level of front of orbits toward snout tip.

*Color.*—Upper surface, in life, olive-brown with many small roundish obscure spots of darker brown on disc; a small dark spot, smaller than pupil, on each side of disc near its inward center; series of small whitish pores extend in three or four rows along midzone of back from region of pectoral girdle to axils of pelvics and extend on to tail in one or two rows; two rows extend rearward and outward on each side of disc posterior to the scapular region; whitish pores also are present opposite and in front of orbits, some extending toward outer margin of disc in sinuous rows. Below jet black everywhere, but this pigment tends to diminish in intensity in preservative.

The other known specimen of this species, 282 mm long, has a somewhat longer snout, the distance in front of orbits being four times the diameter of orbit; the interorbital space is as long as the orbit; the interspace between dorsals is nine-tenths as long as base of first dorsal and there are more teeth  $\frac{1}{2}$ .

As both specimens have very small claspers it is probable that the species attains at least a moderately large size, possibly 2 feet or more in total length.

Nothing is known of the habits of this skate except that it is apparently a moderately deep water species. It is known only from the northwestern part of the Gulf of Mexico as listed above.

***Raja teevani*<sup>3</sup>, n. sp.**

*Study material.* Immature male, 558 mm in total length, holotype, U. S. N. M. no. 153557,

<sup>3</sup> Named for John Tee Van in appreciation of his helpful assistance to us as editor-in-chief of *Fishes of the Western North Atlantic*.

and an immature male 302 mm in total length, paratype, M. C. Z. no. 37189, both from lat. 29° 11' N.; long. 86° 52' W., in 305 fathoms, Oregon station 279.

*Distinctive characters.*—*Raja teevani* differs from all other rajids in the western North Atlantic in its broad tail, which widens rearward approaching the dorsal fins (in all other rajids it narrows rearward). It resembles *R. olseni* and *R. laevis* in general appearance and in lacking thorns along the midbelt of the disc from the level of the axils of the pectorals to the vicinity of the spiracles. But it differs from *olseni* by having no interspace between the bases of the dorsal fins; from *laevis* of comparable size it may be separated by its longer snout (the distance from tip of snout to eye being about one-fourth to one-third the width of the disc in *teevani* but only about one-fifth in *laevis*) and by the fact that the anterior margin of the pelvic fins is longer than the distance from its own origin to the rear tip of pelvic (shorter in *laevis*).

*Description of holotype.*—Proportional dimensions in percent of total length:

Disc.—Extreme breadth 72.7; length 58.2.

Snout length.—In front of orbits 22.2; in front of mouth 24.2.

Orbits.—Horizontal diameter 3.2; distance between 4.1.

Spiracles.—Length 2.0; distance between 6.1.

Mouth.—Breadth 7.7.

Exposed nostrils.—Distance between inner ends 8.7.

Gill openings.—Length, first 1.7; third 1.8; fifth 1.2; distance between inner ends, first 13.8; fifth 8.4.

First dorsal fin.—Vertical height 2.7; length of base 4.3.

Second dorsal fin.—Vertical height 2.7; length of base 4.0.

Pelvics.—Anterior margin 14.7.

Distance from tip of snout to center of cloaca 51.7; from center of cloaca to first dorsal 34.3; to tip of tail 48.3; from rear end of second dorsal base to tip of tail 5.4.

Interspace between first and second dorsals 0.0.

Disc about 1.25 times as broad as long, the maximum anterior angle in front of spiracles about 70°; anterior margins sinuous from snout to outer corners, being slightly convex a little in front of orbits; outer corners very sharply rounded; posterior margins gently convex; posterior corners broadly rounded. Axis of greatest breadth about 77 percent of distance back from tip of snout to axils of pectorals. Tail with a lateral fold low down on each side beginning al-

most imperceptibly about opposite tips of pelvis, widening rearward and ending opposite middle of caudal fin, its length from center of cloaca to origin of first dorsal fin 0.66 as great and to its tip 0.93 times as great as distance from center of cloaca to tip of snout.

Three small thorns along inner margin of left orbit, two of them anterior and one posterior; one anterior and one posterior thorn along inner margin of right orbit; minute prickles scattered

over interorbital area and over entire disc anterior to the orbits. Tail with a median row of 15 backward pointing thorns, beginning about an eye's diameter posterior to the axils of pelvis and ending a little in front of first dorsal, the thorns somewhat more closely spaced and larger rearward than near their origin; minute prickles on tail from about tips of pelvis nearly to tip; dorsals and caudal with a few minute prickles. Lower surface with a band of prickles along anterior

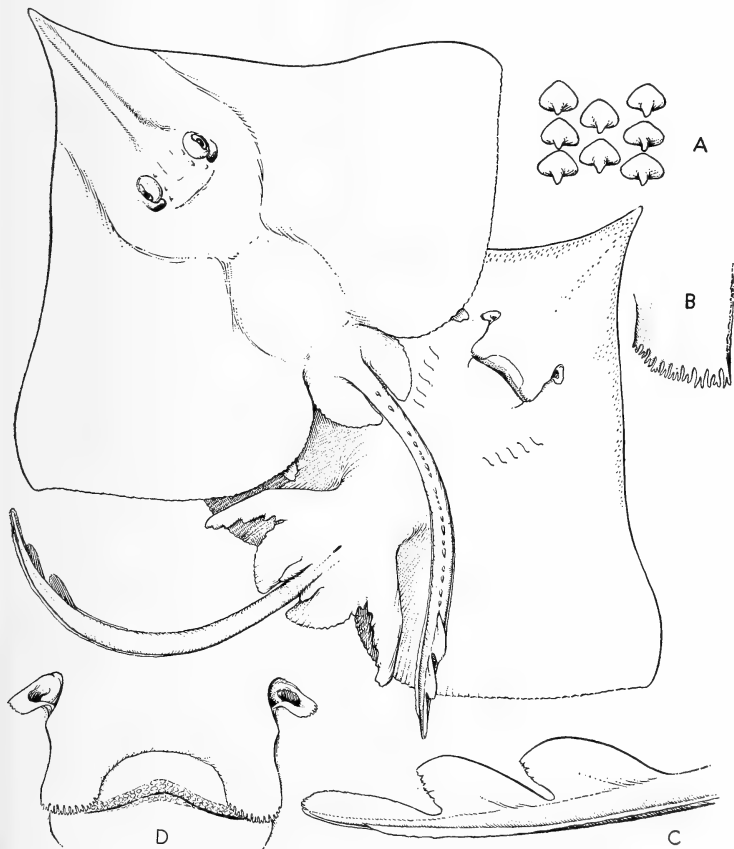

FIG. 3.—*Raja teevani*, n.sp., male, 558 mm long, holotype (U.S.N.M. no. 153557): A, Upper teeth, about  $\times 6$ ; B, margin of left nasal curtain about  $\times 2.5$ ; C, posterior part of tail, about  $\times 1$ ; D, mouth and nostrils, about  $\times 1$ .

margin of disc from a little posterior to level of mouth to tip of snout and also along anterior half of rostral cartilage.

Snout in front of orbits 6.9 times as long as orbit; its length in front of mouth 3.6 times as great as distance between exposed nostrils. Distance between orbits 1.3 times as great as orbit. Orbit 1.6 times as long as spiracle. Nasal curtain fringed; expanded posterior (outer) margins of nostrils smooth except for a few fringes on extreme outer angle. Upper and lower jaws moderately arched centrally. Teeth  $\frac{3}{4}$ , rather widely spaced, in quineunx, triangular or ovate, with smooth rounded apex on outward margin and a low triangular cusp, pointing inward, on inner margin. Distance between first gill openings 1.6 times as great as distance between exposed nostrils; between fifth gill openings about 1.0 times; first gill openings 1.4 times as long as fifth and 0.22 as long as breadth of mouth. First and second dorsals similar in size and shape. No interspace between dorsals. Caudal membrane from rear end of base of second dorsal 1.25 times as long as base of first dorsal. Pelvics deeply concave, strongly scalloped along anterior side of excavation but only weakly so rearward; anterior margin 1.1 times as long as distance from its own origin to rear tip of pelvics; anterior lobe moderately slender, including five radial cartilages besides the first stout one; posterior lobe convex outwardly; rear tips abruptly rounded, extending about one-fifth the distance from axil of pelvics toward first dorsal; inner margin straight. Claspers falling well short of tips of pelvics.

Rostal cartilage firm, narrow, extending to tip of snout. Anterior pectoral rays reaching only about two-fifths the distance from level of front of orbits toward tip of snout. Translucent area in front of orbits and on either side of rostral cartilage very thin and membranous.

*Color.*—Upper surface pale brown, somewhat darker along posterior margins of disc, on pelvics and on tail. Dorsal fins and caudal black. Below creamy on disc except somewhat dusky along outer margins from outer angle rearward and on pelvics. Probably blackish everywhere in life. Tail blackish.

The other known specimen of this species, 302 mm long, has a somewhat shorter snout, the distance in front of orbits being 5.5 times as long as orbit and a relatively longer tail the distance from center of cloaca to tip of tail being 1.1 times as great as distance from center of cloaca to tip of

snout. There is one sharp backward pointing spine on the anterior inner margin of each orbit and another on the posterior inner margin. The color of the upper surface is similar to that of the type except that there is a narrow black margin along the posterior edge of the disc and the lower surface is distinctly margined with black rearward from the level of the mouth; the rear parts of the pelvics also are blackish.

The very small claspers on the larger specimen indicate that this species attains at least a moderately large size.

Nothing is known of its habits beyond the fact that our two specimens were taken at a depth of 305 fathoms. It is known only from the offing of Pensacola, Fla.

#### *Hydrolagus alberti*<sup>4</sup>, n. sp.

*Study material.*—Immature male, 275 mm long to origin of upper caudal fin, holotype (U. S. N. M. no. 153558); male, 280 mm and female 275 mm, paratypes, all from lat. 29° 11' N., long. 86° 52' W., 305 fathoms, Oregon station 279.

*Distinctive characters.*—This newly discovered chimaerid is marked off from its genus mate *affinis* by its very long caudal filament, its relatively much longer pectorals, and its very much larger eyes. It resembles the Japanese *H. himi-sukurii* very closely but differs from it by having a shorter dorsal spine, longer pectorals and more conspicuously waved lateral line anteriorly.

*Description of holotype.*—Proportional dimensions in percent of distance between snout and origin of upper caudal fin:

Trunk.—Breadth 10.9; height 15.6.

Snout length.—In front of eye 9.5; in front of mouth 10.5.

Eye.—Horizontal diameter 7.6; vertical diameter 5.8.

Mouth.—Breadth 5.5.

Nostrils.—Distance between 0.4.

Dorsal spine.—Length 15.3.

First dorsal fin.—Length of base to lowest point between dorsals 13.8.

Second dorsal fin.—Length of base 64.7.

Upper caudal fin<sup>5</sup>.—Length of base to last horny ray 19.3.

Pectoral fin.—Length 31.6; breadth 16.3.

Distance from snout to origin of dorsal spine 24.4; second dorsal 38.2; pectorals 23.2; pelvics 45.5.

Distance from origin to origin of pectorals and pelvics 26.6.

<sup>4</sup> Named for Albert E. Parr in recognition of his many contributions to ichthyology.

<sup>5</sup> The point of origin of the lower caudal fin is not evident.

Trunk opposite dorsal spine about as high as distance from snout to posterior margin of eye; about one-half as high close behind pelvics, tapering evenly thence rearward and terminating in a long filament which, when complete, is about two-thirds the length of body from snout to termination of caudal fin; strongly compressed laterally posterior to head, increasingly so rearward, its thickness about three-quarters as great as its height opposite bases of pectoral fins and one-half as great opposite bases of pelvic fins.

Skin perfectly smooth on immature specimen.

Head about 21 percent of length of trunk to upper origin of caudal fin. Snout conical with blunt tip. Eye oval, sloping a little rearward, its horizontal diameter about 1.3 times its vertical diameter; distance from tip of snout to front of eye about two-fifths length of head to origin of pectorals; pupil one-half vertical diameter of eye;

height of eye about two-fifths of height of head, its length about one-third length of head to origin of pectorals. Exposed subdivision of nostrils crescentic on inner edge, about  $1\frac{1}{2}$  times as long as broad, its length about 15 percent as great as length of eye; distance from its own rear edge to free edge of upper lip about as long as its own length. Width of mouth, when closed, a little less than length of eye.

Lateral mucous canal with a short and abrupt wave opposite the anterior part of first dorsal fin, after which there is a long low dip opposite origin of second dorsal fin, thence continuing nearly straight along the upper part of the caudal axis, descending at origin of caudal fin to follow out along lower edge of caudal axis. Junction of cranial canal with aural canal somewhat more acute than a right angle; anterior course of cranial canal nearly straight, looping down in front of eye;

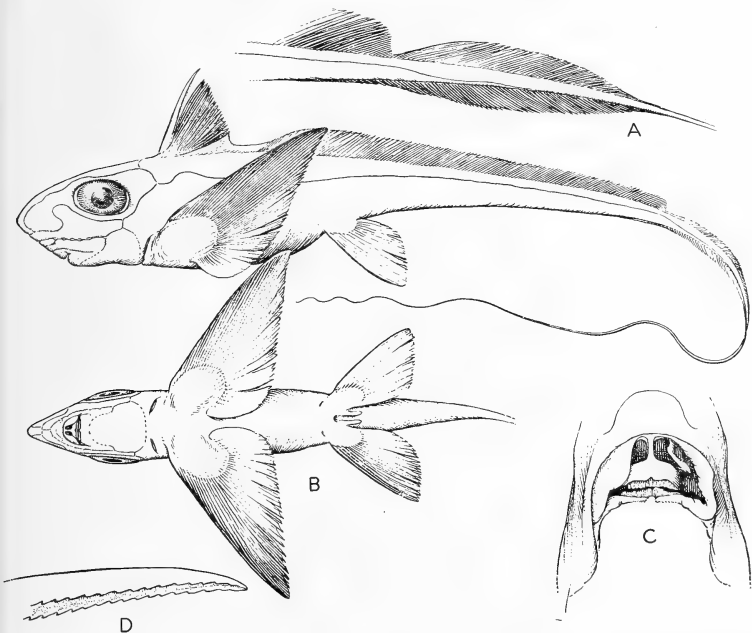

FIG. 4.—*Hydrolagus alberti*, n.sp., male, 275 mm long to origin of upper caudal fin, holotype (U.S.N.M. no. 153558): A, Posterior part of second dorsal fin and upper and lower caudal fins, about  $\times 1$ ; B, ventral view of head and body; C, mouth, with left lip folded aside to show nostrils and dental plates, about  $\times 2$ ; D, tip of dorsal spine, about  $\times 2.5$ .

jugular and oral canals running downward from suborbital as a joint canal for a short distance before separating. About 10-12 medium size pores close in front of occipital canal; about 12 pores in area bounded by suborbital and joint oral-jugular canals; about 10 large openings along angular canal to front of snout; a single row of about 15 small pores parallel to descending oval branch and continuing in front of it; about 8 or 9 large openings along anterior part of suborbital canal from its descending wave to front of snout; jugular canal continued downward onto throat as a series of short slits. Skin closely pock-marked on top and on upper sides of head abreast of mouth and nostrils and toward tip of snout, with many rounded depressions of different sizes.

Anterior upper (vomarine) dental plates quadrate, their outer anterior outlines convex, with six radial ridges. Posterior upper (palatine) plates about 2.75 times as long as anterior plates, triangular, the posterior margin about two-thirds as long as outer margin, surface lumpy, with four prominent ridges running longitudinally. Lower (mandibular) plates nearly as long as posterior upper plates, each plate with a double concavity and central ridge on inner surface, the cutting edge uneven, highest at center of mouth.

Gill openings nearly one-half as long as distance from tip to snout to front of eye, distance across throat between their lower ends about one-half as long as eye, fold across throat strongly marked.

Dorsal spine about as long as distance from tip of snout to rear edge of pupil, reaching slightly beyond apex of first dorsal fin; outer part free from first dorsal fin, the rear face with two rows of low sharp thorns pointing toward base. First dorsal fin with sharp angle at apex and straight posterior margin; its base (from origin of spine to bottom of inter-dorsal notch) nearly as long as height along anterior margin of fin. Distance between first dorsal (when slightly depressed) and first noticeable elevation of second dorsal about two-fifths as long as anterior margin of first dorsal.

Second dorsal with horny rays easily distin-

guishable, upper margin nearly straight; height at midlength about one-fifth as great as length of anterior margin of first dorsal; about equally great at rear end and slightly greater toward anterior end; posterior outline of second dorsal curving abruptly downward. No definite interspace between second dorsal and upper origin of caudal. Caudal lanceolate, prolonged into a long filament about four-fifths as long as distance from snout to rear end of second dorsal; maximum height of caudal above axis about two-thirds height of second dorsal at posterior end; its extreme length to most posterior ray about 9 times as great as its height; caudal below axis about four-fifths as wide as above; the most posterior rays of both upper and lower sides of caudal terminate almost imperceptibly and about opposite each other; origin of lower side of caudal indefinite in position, preceded by a low fleshy ridge distinguishable forward to a point above and opposite beginning of last third of second dorsal fin. Pelvic fins with weakly convex anterior and distal margins, subangular outer corners and gradually rounded posterior (inner) corners; length of pelvis along anterior margin about as great as distance from tip of snout to middle of eye; origin posterior to axils of pectorals by a distance about equal to that from tip of snout to origin of pectorals. Pectoral fins about three-tenths as long as distance from tip of snout to opposite rear part of second dorsal fin; tips, when laid back, extending just beyond the base of pelvic; anterior margin weakly convex; distal margin straight or slightly concave; apex sharp pointed; inner corner broadly rounded.

Prepelvic openings present. Frontal tenaculum embedded in skin in this immature male. Claspers bifid but may develop as trifold with age.

*Color*.—Dark brownish everywhere on head and body above and below; fins somewhat darker.

The female closely resembles the male but lacks the prepelvic openings and, of course, the frontal tenaculum.

This species is known only from the offing of Pensacola, Fla., in a depth of 305 fathoms.



**NEMATOTOLOGY.**—*Effects of potassium nutrition and amount of inoculum on rate of reproduction of Meloidogyne incognita.* BAKIR A. OTEIFA, University of Maryland and U. S. Bureau of Plant Industry, on leave from Fouad 1, University, Giza, Egypt. (Communicated by G. Steiner.)

It is well established that nutritional conditions of host plants have a marked influence on development of various bacteria and fungi that parasitize them. As far as can be determined no information is available regarding such influence on development of parasitic nematodes. Godfrey and Oliveira (1932) have shown that the length of time required for reproduction of root-knot nematodes depends on the type of host plant used. Other authors (Chitwood, 1951; Christie, 1949) have indicated that various plant species react differently to the same nematode. In this connection question was raised whether the mineral composition of the host plant affects the reproduction of the nematode infecting it. The present study attempts to ascertain the effect of low, medium and high concentrations of potassium in a host plant upon the production of females and egg masses of the root-knot nematode, *Meloidogyne incognita* (Kofoid and White, 1919) Chitwood, 1949, infecting it.<sup>1</sup>

Inoculum used in this experiment was obtained from tomato, *Lycopersicon esculentum* Mill. var. Marglobe. The number of *M. incognita* egg masses contained in a finely chopped sample of roots was counted under a binocular microscope; the corresponding weights of roots containing approximately 50 and 200 egg masses, which were the two levels of inoculum used throughout this experiment, were computed. Glazed, 3-gallon crocks were filled to one-quarter of their capacity with a coarse sand of approximately 8-mesh, on top of which a finer sand of approximately 40-mesh was added so that the pot was about half full. Chopped roots containing the required amount of inoculum in each case were distributed evenly over the surface, after which an additional layer of the finer sand was added to raise the surface to about 2 inches from the top of the crock. Seedlings of lima bean, *Phaseolus lunatus* L.

var. Henderson that had been germinated in pure quartz sand were transplanted to the crocks when in the 3- or 4-leaf stage.

Composition of nutrient solutions used in the experiment is shown in Table 1. All standard compounds used were of C.P. grade. Immediately after transplanting, each crock received 250 ml of the nutrient solution desired after which additional applications of 400 to 500 ml per crock were added when needed to maintain the proper moisture level. Crocks were flushed weekly with tap water in order to prevent any accumulation of salts.

The experimental design was a randomized complete block with four replications. During the course of the experiment greenhouse temperature varied from 65° to 85°F., with an average temperature of 75°F.

After 70 days the plants had reached maturity and roots of each plant were washed free of sand and rinsed in tap water. After drainage for a few seconds, root weights were recorded and the root-gall index was determined. This index was based on the relative amount of root galling, the root system being classified as follows: 0—no evidence of galling; 1—trace of galling; 2—moderate galling; 3—extensive galling; 4—severe galling. The roots were then finely chopped and the number of females and egg masses in one gram of roots from each plant was counted. Results are given in Table 2. Examination

TABLE 1.—COMPOSITION OF NUTRIENT SOLUTIONS USED

Stock solutions	Ml stock/liter of nutrient solution		
	Low	Medium	High
M/1 Ca(NO <sub>3</sub> ) <sub>2</sub> .....	5.0	5.0	5.0
M/1 KNO <sub>3</sub> .....	0.0	5.0	5.0
M/1 NaNO <sub>3</sub> .....	5.0	0.0	0.0
M/1 KCl.....	0.5	0.0	4.0
M/1 NaCl.....	4.0	4.5	0.5
M/1 MgSO <sub>4</sub> .....	2.0	2.0	2.0
M/1 KH <sub>2</sub> PO <sub>4</sub> .....	0.0	1.0	1.0
M/1 NaH <sub>2</sub> PO <sub>4</sub> .....	1.0	0.0	0.0
A-Z <sup>a</sup> .....	1.0	1.0	1.0

<sup>a</sup> Micronutrient solution as described by Hoagland and Snyder (1933).

<sup>1</sup> This experiment was carried out in cooperation with the Division of Nematology, Bureau of Plant Industry, Soils, and Agricultural Engineering, Beltsville, Md.

of the data reveals that the average increase in number of females and egg masses was significant with each increase in concentration of potassium. The mean effect of increase of inoculum increment was likewise highly significant in increasing the number of females and egg masses produced.

Chitwood (1951) has shown that with certain root-attacking nematodes the mean number of females and the mean number of egg masses produced per unit of inoculum were inversely proportional to the amount of inoculum. The present results confirm this (Table 2). For each of the medium and high potassium levels it was found that an increase of egg masses in the inoculum resulted in a corresponding significant decrease in number of mature females as well as a decrease in number of egg masses produced on the test plants. However, in the cases of low potassium level this relationship was only slightly evident. This indicates that the number of egg masses produced per unit of inoculum may be influenced by the amount of potassium available.

Reproductive activities of the nematodes may be limited more by availability of potassium than by amount of root space available to the nematode. When potassium was low the average number of egg masses produced per unit of inoculum was five and the mean root weight per plant was 12 gm. When the level of potassium was medium the mean number of egg masses produced per unit of inoculum was 30, or six times as great as that of the low potassium level,

while the average root weight was 27 gm or only slightly more than double the root weight for the low potassium level. When potassium level was high the mean number of egg masses produced per unit of inoculum was 32 and the root weight was 25 gm, indicating that an increase in potassium level from medium to high had little effect on the corresponding root weight and number of egg masses produced per unit inoculum. Thus while root weight increases by a factor of 2 from the low to the medium and high potassium levels the number of egg masses produced per unit inoculum increases by the factor 6.

These data indicate that the maximum number of females which the roots can support under the medium and high potassium levels was in the vicinity of 350 females per gram of root. When roots were infected to that extent the rate of reproduction, which was obtained by dividing the number of egg masses by the number of mature females, was about 0.5. Plants inoculated with 200 egg masses and given the high level of potassium did not support a greater number of females and egg masses than such plants receiving the medium level of potassium. Similar results were evident in the comparison of root gall indices of these plants. Such failure was attributed to the effects of overcrowding. When roots were not heavily infected, as in the case of plants receiving 50 units of inoculum, the number of egg masses per gram of root increased with the increase in potassium level. Rate of reproduction was

TABLE 2.—RELATIONSHIP OF POTASSIUM NUTRITION AND AMOUNT OF INOCULUM TO RATE OF REPRODUCTION OF MELOIDOGYNE INCOGNITA

Potassium levels	Units of inoculum (egg masses)	Mean root-gall index	Mean root weight	Mean number of females			Mean number of egg masses			Mean rate <sup>c</sup> of reproduction
				per gm root	per plant	per unit <sup>a</sup> inoculum	per gm per		per unit <sup>b</sup> inoculum	
							root	plant		
			gm							
Low	50	3.2	9.2	117	1084	22	20	200	4	0.168
	200	3.8	15.0	246	3675	18	83	1229	6	0.334
Medium	50	2.7	32.5	126	4079	82	54	1665	32	0.428
	200	4.0	23.1	346	8034	40	196	4564	28	0.568
High	50	3.0	21.2	158	3330	67	108	2281	45	0.588
	200	4.0	21.1	361	7668	39	186	3964	20	0.514
LSD <sup>d</sup>	.05		5.8	16.9	589.0	10.6	13.7	305.8	5.7	0.173
	.01		7.8	23.2	807.8	14.6	18.8	419.3	7.9	0.236

<sup>a</sup> Females per plant divided by egg masses in inoculum.

<sup>b</sup> Egg masses per plant divided by egg masses in inoculum.

<sup>c</sup> Number of egg masses divided by number of mature females.

<sup>d</sup> Least significant differences.

also increased significantly with an increase in the 3 potassium levels: 0.168, 0.428, and 0.688, respectively.

Among plants receiving a relatively low amount of inoculum, rates of reproduction were apparently limited by the amount of potassium available, as indicated by the highly significant differences between treatments. On the other hand, with higher amounts of nematode inoculum an increase in potassium correspondingly increased the rate of reproduction up to a certain point between that produced by the medium and high levels of potassium. Thus it seems that rates of reproduction of nematodes among plants receiving medium and high levels of potassium are correlated with the amount of root available and with competition between nematodes for living space in the roots rather than the amount of potassium available.

#### SUMMARY

Lima-bean plants grown in sand cultures were inoculated with the root-knot nematode *Meloidogyne incognita*. Three nutrient treatments were employed supplying low, intermediate and high potassium concentrations. Two levels of nematode inoculum were used at rates of 50 and 200 egg masses.

Results of this experiment are:

1. Differences in the number of female nematodes produced on the roots and differ-

ences in the rate of their oviposition can be induced by variations in potassium concentrations.

2. Among plants receiving a relatively low amount of inoculum, rates of nematode reproduction were apparently limited by the amount of potassium available.

3. In plants receiving relatively higher inoculum and treated with higher potassium concentrations, rates of reproduction are correlated with the amount of root available and with competition between nematodes for root space rather than with the amount of potassium available.

#### REFERENCES

- CHITWOOD, B. G. *Root knot nematodes—Part I: A revision of the genus Meloidogyne Goeldi, 1887.* Proc. Helm. Soc. Washington **16**(2): 90-104. 1949.
- . *Root-knot nematodes. II. Quantitative relations of the root-knot nematode—Meloidogyne hapla Chitwood, 1949 with tomatoes, onions and lima beans.* Plant and Soil **111**(B): 47-50. 1951.
- CHRISTIE, J. R. *Host-parasite relationships of the root-knot nematode, Meloidogyne spp. III. The nature of resistance in plants to root knot.* Proc. Helm. Soc. Washington. **16**(2): 104-108. 1949.
- GODFREY, G. H., and OLIVEIRA, J. *The development of root-knot nematode in relation to root tissues of pineapple and cowpea.* Phytopath. **22**(4): 325-348. 1932.
- HOAGLAND, D. R., and SYNDER, W. R. *Nutrition of the strawberry plant under controlled conditions.* Proc. Amer. Soc. Hort. Sci. **30**: 288-294. 1933.

ZOOLOGY.—*The last copepodid instar of Diaptomus sanguineus Forbes (Copepoda).*

ARTHUR G. HUMES, Boston University, Boston, Mass., and MILDRED STRATTON WILSON, Arctic Health Research Center, Anchorage, Alaska.

The larval stages of *Diaptomus vulgaris* Schmeil have been described by Grandori (1912) and those of *D. castor* (Jurine) by Dietrich (1915) and Gurney (1931). Nauplii and copepodids of North American diptomids, however, are almost entirely unknown. Ewers (1930) described the nauplius stages of *D. siciloides* Lilljeborg. C. B. Wilson (1932) described briefly the fifth leg of "young" male and female *D. leptopus* Forbes and the fifth leg of "undeveloped" male and female *D. oregonensis* Lilljeborg, both of these immature forms being apparently the last copepodid stage.

It is the purpose of this paper to describe the last copepodid instar of *D. sanguineus*

Forbes and in so doing to supply certain details of the structure of the adult that were not mentioned in Forbes' descriptions (1876, 1882) or by later authors. Since large numbers of the last copepodid stage of both sexes may occur in plankton, along with adults of this and often other species, it is desirable to be able to correlate this immature stage with its adult form.

The specimens of *D. sanguineus* upon which the following description is based were collected from a small ice-covered pond in Weston, Mass., in February and March of 1950 and 1951. The copepods were studied entire and dissected, as stained mounts in balsam, as unstained mounts in glycerin, or

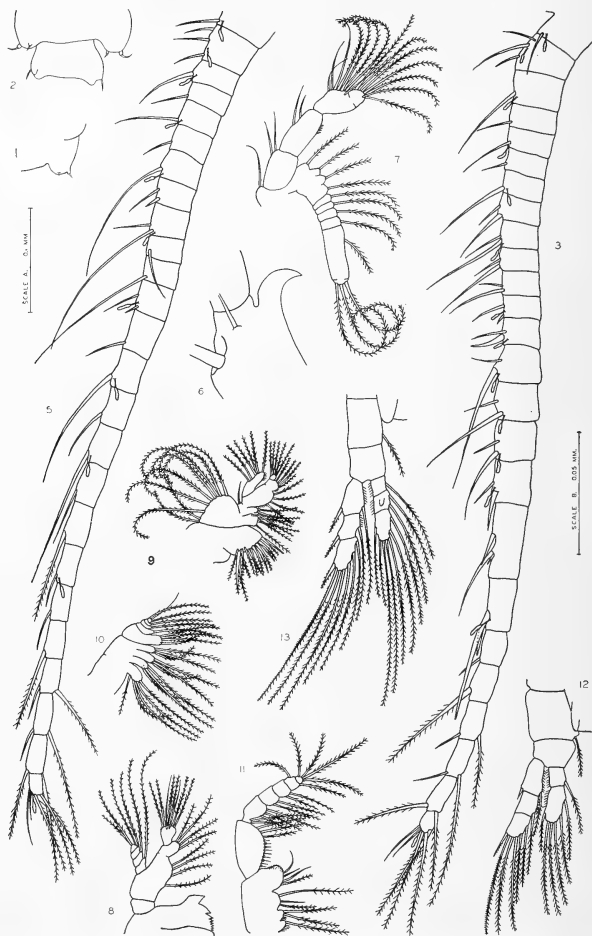

FIGS. 1-13.—*Diaptomus sanguineus* Forbes: 1, Last copepodid of male, last metasomal somite, one side only; 2, adult male, last metasomal somite and genital segment; 3, last copepodid of male, right antennule; 4, adult male, right antennule; 5, last copepodid of male, left antennule; 6, adult male, right process on segment 23 of right antennule; 7, last copepodid of male, antenna; 8, same, mandible; 9, same, first maxilla; 10, same, second maxilla; 11, same, maxilliped; 12, same, first swimming leg; 13, same, second swimming leg. (All figures drawn with the aid of a camera lucida. Scale A applies to Fig. 1 only, scale B to Figs. 6, 18, and 19, and scale C to the remaining figures.)

as unstained mounts in water. The last method was most satisfactory for distinguishing the aesthetes and other minute details. Only salient points of difference between the larval and adult stages are described, since many features are better shown by figures. Specimens of both sexes of copepodids and adults have been deposited in the United States National Museum.

*Last copepodid, male.*—The body proportions are similar to those of the adult. The average total length and average sizes of the body regions, based upon 10 copepodid and adult males, measured without pressure, are indicated in Table 1. The metasome reaches its greatest width at the level of the second somite. The posterior lateral areas of the last somite bear a pair of sensory spines, smaller in the copepodid (Fig. 1) than in the adult male (Fig. 2). The urosome consists of four somites, as compared to five in the adult male.

The right antennule (Fig. 3) is slenderer than that of the adult male (Fig. 4), 25-segmented, and nonprehensile. It differs from that of the left side (Fig. 5) in the presence of incipient spines and depressed processes on segments 13 and 17–19. The major spines of 8 and 10–11 are represented in the copepodid by stout setae. The right antennule of the adult is distinguished by the enlargement of the usual minor spine of segment 8, and the presence of a very stout spinous cuticular process on 15. The process of segment 23 is as shown in Fig. 6.

The antenna of the copepodid (Fig. 7) resembles that of the adult, except that in

the latter the joints are somewhat more distinct and there are nine instead of eight setae on the inner side of the last endopodite podomere. The mandible of the copepodid (Fig. 8) is similar to that of the adult, except that in the palp of the latter there are nine instead of eight setae on the last endopodite podomere, and the very reduced fifth podomere of the exopodite is hardly separated. No important structural differences between the copepodid and adult were observed in the first maxilla (Fig. 9), second maxilla (Fig. 10), or maxilliped (Fig. 11). The first (Fig. 12), second (Fig. 13), third, and fourth swimming legs are similar in both instars, although the joints in the copepodid legs are less distinct. The cuticular lobe on the second podomere of the endopodite of the second leg occurs in both instars.

The right fifth leg has a single terminal spine (Fig. 14), and the left three apical spinous processes. In specimens about to molt the form of the adult leg may be seen within the copepodid form (Fig. 15). The adult leg (Fig. 16) is distinguished by the broadened second basipodite segments, that of the right side having a small, inner, proximal lamella and a distinctive elongation of the distal outer corner (Fig. 17). The apical podomere of the left exopodite has prominent chitinized areas on the anterior side (Fig. 18), that at the base of the proximal process emphasizes the extended, pointed portion of the segmental body which is of systematic importance. The pads are well developed, the proximal being medially placed and bulging, the distal confined largely to the posterior face (Fig. 19).

TABLE 1.—MEASUREMENTS (IN MICRONS) OF LAST COPEPODID AND ADULT INSTARS OF DIAPTOMUS SANGUINEUS, EACH FIGURE REPRESENTING THE AVERAGE OF 10 SPECIMENS

Body region	Copepodid male	Adult male	Copepodid female	Adult female
Total length.....	1367 (1287–1430)	1591 (1515–1701)	1522 (1500–1558)	1730 (1689–1773)
Head.....	336 × 323	361 × 342	353 × 356	391 × 387
First thoracic.....	130 × 323	143 × 347	145 × 351	157 × 406
Second thoracic.....	136 × 336	163 × 359	158 × 372	181 × 422
Third thoracic.....	105 × 326	123 × 352	121 × 364	140 × 409
Fourth thoracic.....	98 × 296	115 × 325	120 × 333	132 × 380
Fifth thoracic.....	87 × 257	102 × 285	107 × 289	128 × 347
Sixth thoracic.....	64 × 196	71 × 226	79 × 240	121 × 302
First abdominal.....	67 × 125	82 × 134		
Second abdominal.....	84 × 105	104 × 100	162 × 145	201 × 169
Third abdominal.....	73 × 98	96 × 93	81 × 110	65 × 98
Fourth abdominal.....	100 × 100	89 × 90	108 × 113	77 × 117
Fifth abdominal.....		64 × 98		
C. ud. I ramus.....	105 × 48	110 × 46	103 × 54	107 × 55

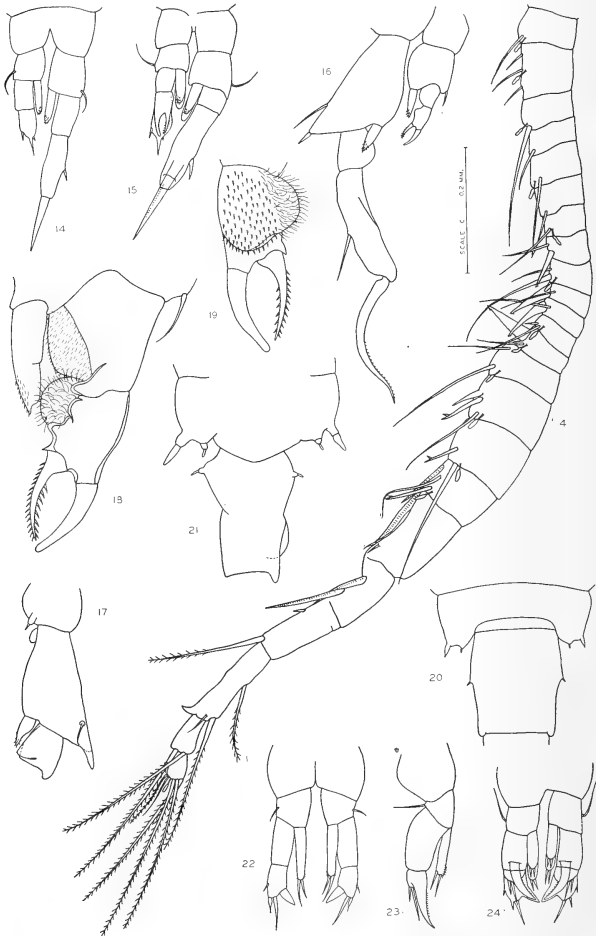

FIGS. 14-24.—*Diaptomus sanguineus* Forbes: 14, Last coepodid of male, fifth pair of legs; 15, same, fifth pair of legs about to molt; 16, adult male, fifth pair of legs; 17, same, basal segments of leg 5, turned somewhat medially to show lamella of second basal segment in profile; 18, same, left fifth leg, anterior view; 19, same, left fifth leg, distal portion of exopodite, posterior view; 20, last coepodid of female, last metasomal somite and genital segment; 21, adult female, last metasomal somite and genital segment; 22, last coepodid of female, fifth pair of legs; 23, adult female, fifth leg; 24, last coepodid of female, fifth pair of legs about to molt.

*Last copepodid, female.*—The outline of the body is similar to that of the male. The average measurements for both copepodid and adult females, corresponding to those given for the male, are indicated in Table 1. The pair of sensilla on each side of the last metasomal somite (Fig. 20) are smaller than the prominent ones of the adult (Fig. 21) which are highly characteristic of *D. sanguineus*. The urosome in both instars consists of three somites. The genital segment of the copepodid (Fig. 20) is simple, but that of the adult is elongate and asymmetrical (Fig. 21).

The right and left antennules are similar in both instars, resembling the nonprehensile appendages of the males. The species is of the "little setaceous" type, having only one seta on segments 11 and 13-19. The antennae and mandibles differ in the two instars in the same way as in the male. The first and second maxillae, maxillipeds, and first through fourth legs are similar to those of the male.

The fifth leg in the copepodid (Fig. 22) differs from the adult in the presence of the lateral seta of the second exopodite podomere. The prominent claw of the adult (Fig. 23) is weakly developed. In specimens about to molt the form of the adult female may be seen within (Fig. 24).

**BOTANY.**—*A study of the roots of Pinus virginiana in relation to certain Hymenomyces suspected of being mycorrhizal.* EDWARD HACSKAYLO, George Washington University. (Communicated by William W. Diehl.)

The occurrence of ectotrophic mycorrhizae on *Pinus virginiana* Mill., a common conifer of the eastern United States, has been referred to by Henry (1), Kelley (2), McComb (4), and McDougall (5), but no mention was made concerning the identity of the fungi involved in the relationship with this tree species. Inasmuch as fungal cultures could be obtained from sporophores collected from a stand of pine, it would be possible to determine experimentally the identity of some of those species associated in the mycorrhizae of *P. virginiana*. This could be accomplished by subjecting seedlings germinated under aseptic conditions to simple inoculation tests using pure cultures of each fungus suspected

The principal points of difference between the last copepodid and the adult stages, aside from changes in body size and proportions, are found in both sexes in the development of the sensilla of the last metasomal somite, in the number of terminal setae on the endopodites of the antennae and the mandibles, and in the form of the fifth legs. The male is further distinguished by the number of somites in the urosome, and by the structure of the right antennule. The female differs conspicuously in the development of the genital segment.

#### LITERATURE CITED

- DIETRICH, WALTHER. *Die Metamorphose der freilebenden Süßwasser-Copepoden.* Zeitschr. Wiss. Zool. **113**: 252-324. 1915.
- EWERS, LELA A. *The larval development of freshwater Copepoda.* Ohio State Univ., Franz Theodore Stone Lab., Contr. no. 3: 1-43. 1930.
- FORBES, S. A. *List of Illinois Crustacea, with descriptions of new species.* Bull. Illinois Mus. Nat. Hist. **1**: 3-25. 1876.
- . *On some Entomostraca of Lake Michigan and adjacent waters.* Amer. Nat. **16**: 640-649. 1882.
- GRANDORI, REMO. *Studi sullo sviluppo larvale dei copepodi pelagici.* Redia **8**: 360-457. 1912.
- GURNEY, ROBERT. *British fresh-water Copepoda.* Ray Society, London, 1931.
- WILSON, CHARLES BRANCH. *The copepods of the Woods Hole region Massachusetts.* U. S. Nat. Mus. Bull. **158**: 1-635. 1932.

because of its constant association with the pine stands.

Sporophores of several Hymenomyces were collected during the summer and fall of 1949 from two nearly pure stands of *Pinus virginiana* occurring in Virginia near Washington, D. C. The following fungi were identified: *Amanita verna* (Bull.) Quel., *Boletus americanus* Pk., *Boletus* sp., *Clavaria pulchra* Pk., *Lactarius chrysothorus* Fr., *L. piperatus* (Scop.) Fr., *Tricholoma equestre* (L.) Quel., and *T. portentosum* Fr. From young sporophores of the above, tissue fragment cultures were obtained on a 50-50 mixture of commercial potato dextrose and malt dextrose agars.

Seeds of *Pinus virginiana*, purchased from the Herbst Brothers Seed Co., of New York, were surface-sterilized by soaking them for five minutes in a 1:1000 aqueous solution of bichloride of mercury. Following this treatment, the seeds were washed four times with sterile deionized water and then placed on a 2% (Ben Venue<sup>1</sup> green plant) agar medium containing the following amounts of salts per liter: MgSO<sub>4</sub>, 1.2 gm; (NH<sub>4</sub>)<sub>2</sub>SO<sub>4</sub>, 0.2 gm; Ca(NO<sub>3</sub>)<sub>2</sub>, 0.8 gm; KH<sub>2</sub>PO<sub>4</sub>, 0.7 gm and a trace of CuSO<sub>4</sub>. They were germinated aseptically in Petri dishes and urine specimen bottles in a room at approximately 24°C. not exposed to direct sunlight.

In January and February, 1950, 100 pot cultures of pine seedlings were inoculated with the various fungi in culture, and 16 uninoculated controls were prepared. The methods used were similar to those described by McArdle (3) modified as follows. Each 3-inch pot was equipped with a glass subirrigation tube in order to avoid washing surface contaminants into the substrate during watering and applying nutrient solution to the cultures. The end of tube exposed to the air was covered with a glass vial when not in use. The system tended to reduce the amount of moisture on the substrate surface and consequently was not favorable for air-borne contaminants. The nutrient solution used was the same as prescribed by McArdle (3).

The pot cultures were maintained in the greenhouse where growth was generally favorable. There was, however, some variation in the amount of shoot growth among the different cultures.

In April 1950, examination of some of the roots showed profuse dichotomy of the short roots, this having developed in less than four months in cultures containing mycelium of *Amanita verna*. Dichotomy was also present to a lesser extent in the cultures containing mycelium of *Lactarius piperatus* and *Tricholoma portentosum*, but not in the pots con-

taining the other fungi noted above. In free-hand sections of these dichotomous roots, it was found that initials of ectotrophic mycorrhizae had developed since mantles were present. Hyphal penetration was not evident as a well-developed Hartig net. Roots of eight of the control plants were examined and neither dichotomy nor fungus association was found.

The roots of seedlings that were maintained and examined after a period of six to eight months did not appear to be growing actively during late spring and summer. There were neither mycorrhizal nor nonmycorrhizal young roots and very few older structures that resembled mycorrhizae. High temperatures up to 46°C. noted in the greenhouse after April 1 may have inhibited mycorrhizal formation and root development.

These results indicate that *Amanita verna*, *Lactarius piperatus*, and *Tricholoma portentosum* are possibly involved in the mycorrhizae of *Pinus virginiana*. No such indications, however, were found with *Boletus americanus*, *Boletus* sp., *Clavaria pulchra*, *Lactarius chrysorrhoeus*, and *Tricholoma equestre* under the conditions of the experiment. None of the roots of the control plants were found to be associated with a fungus. This work has revealed some of the problems that must be solved in future experimentation and is a forerunner of research now under way.

#### REFERENCES

- (1) HENRY, LER. K. *Mycorrhizas of trees and shrubs*. Bot. Gaz. **94**: 791-800. 1933.
- (2) KELLEY, A. P. *The variations in form of mycorrhizal short-roots of Pinus virginiana Mill. associated with certain soil series*. 10 pp. 1941.
- (3) McARDLE, R. E. *The relation of mycorrhizae to conifer seedlings*. Journ. Agr. Res. **44**: 287-316. 1932.
- (4) McCOMB, A. L. *Mycorrhizae and phosphorous nutrition of pine seedlings in a prairie soil nursery*. Iowa Agr. Exp. Stat. Res. Bull. **314**: 582-612. 1943.
- (5) McDougall, W. B. *Mycorrhizas from North Carolina and eastern Tennessee*. Amer. Journ. Bot. **15**: 141-148. 1928.

<sup>1</sup> Ben Venue Laboratories, Bedford, Ohio.



# INDEX TO VOLUME 41

## PROCEEDINGS OF THE ACADEMY AND AFFILIATED SOCIETIES

Anthropological Society of Washington. 307.

Washington Academy of Sciences. 48, 115, 148, 238.

### AUTHOR INDEX

- ABBOTT, DONALD P. *Bostrichobranchus digonas*, a new molgulid ascidian from Florida. 302.
- ABBOTT, R. TUCKER. New stenothyrid gastropods from the Philippines (Rissoidae). 14.
- and LADD, H. S. A new brackish-water gastropod from Texas (Amnicolidae: Littoridina). 335.
- See also REHDER, HARALD. 22.
- ALLARD, H. A. *Dinoponera gigantea* (Perty), a vicious stinging ant. 88.
- ARCHER, W. ANDREW. See JENKINS, ANNA E. 66.
- BARTSCH, PAUL. More urocoptid mollusks from Mexico. 146.
- BAYER, FREDERICK M. A revision of the nomenclature of the Gorgoniidae (Coelenterata: Octocorallia), with an illustrated key to the genera. 91.
- Two new primnoid corals of the subfamily Calyptrophorinae (Coelenterata: Octocorallia). 40.
- BEELE, WILLIAM H., and SELANDER, ROBERT J. The systematic relationships of the fox sparrows (*Passerella iliaca*) of the Wasatch Mountains, Utah, and the Great Basin. 364.
- BERKELEY, E. and C. A second record of the polychaetous annelid *Potamethus elongatus* (Treadwell). 333.
- BIGELOW, HENRY B., and SCHROEDER, WILLIAM C. Three new skates and a new chimaerid fish from the Gulf of Mexico. 383.
- A new genus and species of anacanthobatid skate from the Gulf of Mexico. 110.
- BITANCOURT, A. A. See JENKINS, ANNA E. 66.
- BLAKE, DORIS H. New species of chrysomelid beetles of the genera *Trirhabda* and *Disonycha*. 324.
- BURLEY, GORDON. See KRACEK, F. C. 373.
- CAMPBELL, T. N. Medicinal plants used by Choctaw, Chickasaw, and Creek Indians in the early nineteenth century. 285.
- CARR, LLOYD G. K. Interesting animal foods, medicines, and omens of the eastern Indians, with comparisons to ancient European practices. 229.
- CHACE, FENNER A., JR. The grass shrimps of the genus *Hippolyte* from the west coast of North America. 35.
- The number of species of decapod and stomatopod Crustacea. 370.
- CAUSEY, NELL B. New cleidogonid millipeds (Chordeuimoidea). 78.
- CHALKLEY, H. W. See CORNFIELD, JEROME. 226.
- CLARK, AUSTIN H. The brittle-stars of the United States Navy Antarctic Expedition 1947-48. 26.
- CLARKE, J. F. GATES. A new genus and species of North American Olethreutidae (Lepidoptera: Laspeyresinae). 46.
- New species of Gelechiidae from Argentina (Lepidoptera). 140.
- New species of Olethreutidae from Argentina. 296.
- COE, WESLEY R. Geographical distribution of the nemerteans of the northern coast of the Gulf of Mexico as compared with those of the southern coast of Florida, with descriptions of three new species. 328.
- COOPER, G. ARTHUR. New brachiopods from the Lower Cambrian of Virginia. 4.
- and MUIR-WOOD, HELEN M. Brachiopod homonyms. 195.
- CORNFIELD, JEROME, and CHALKLEY, HAROLD W. A problem in geometric probability. 226.
- CURTIN, PHILIP D. A survey of new archeological sites in central Pataz, Peru. 49.
- DALQUEST, WALTER W. Six new mammals from the state of San Luis Potosi, Mexico. 361.
- DAVENPORT, DESMOREST. See LOOMIS, H. F. 270.
- DEXTER, RALPH W. See SPECK, FRANK G. 250.
- DRAKE, CARL J. New American chinch bugs (Hemiptera: Lygaeidae). 319.
- DUNKLE, DAVID H. New Western Hemisphere occurrences of fossil selachians. 344.
- DURBIN, CHARLES G., and HONESS, RALPH F. A new roundworm, *Nematodirus rufaeavstitatis* (Nematoda: Trichostrongylidae), from domestic sheep, *Ovis aries*, in Wyoming. 179.
- EMERSON, WILLIAM K. A new scaphopod mollusk, *Cadulus austinclarki*, from the Gulf of California. 24.
- FRIEDMANN, HERBERT. Dedication [to Austin Hobart Clark issue]. 1.
- GARDNER, JULIA. Two new guide fossils from the Tallahatta formation of the Southeastern States. 8.
- GRYC, GEORGE, PATTON, W. W., JR., and PAYNE, T. G. Present Cretaceous stratigraphic nomenclature of northern Alaska. 159.
- GWILLIAM, G. F. See HAND, CADET. 206.
- HAAAS, VICTOR H. Disaster and disease. 277.
- HACKMAN, ROBERT J. See SOLECKI, RALPH S. 85.
- HACKSKAYLO, EDWARD. A study of the roots of *Pinus virginiana* in relation to certain Hymenomyces suspected of being mycorrhizal. 399.
- HAND, CADET, and GWILLIAM, G. F. New distributional records for two athecate hydroids, *Cordylophora lacustris* and *Candelabrum* sp., from the west coast of North America, with revisions of their nomenclature. 206.
- HEYL, PAUL R. The limitations of the principle of superposition, II. 149.
- HOBBS, HORTON H., JR. A new crayfish of the genus *Procambarus* from Louisiana, with a key to the species of the *Spiculifer* group. 272.
- HOFFMAN, RICHARD L. The diplopod family Camponesmidae (Polydesmida). 209.
- HONESS, RALPH F. See DURBIN, CHARLES G. 179.
- HUMES, ARTHUR G., and WILSON, MILDRED STRATTON. The last copepodid instar of *Diatomus sanguineus* Forbes (Copepoda). 395.
- ILLG, PAUL L. A new genus and species of notodelphyoid copepod from Japan. 30.

- JENKINS, ANNA E., BITANCOURT, A. A., SILBERSCHMIDT, K., and ARCHER, W. ANDREW. Peter Wilhelm Lund's pequi tree at Lagoa Santa and pilgrimages to his cemetery. 66.
- JOHNSTON, FRANCIS E. The theory of group representations. 117.
- KENG, HSÜAN. New or critical Euphorbiaceae from eastern Asia. 200.
- KRACEK, F. C., NEUVONEN, K. J., and BURLEY, GORDON. Thermochemistry of mineral substances, I: A thermodynamic study of the stability of jadeite. 373.
- KRISHNASWAMY, K. Notes on the undescribed males of two species of Copepoda. 75.
- LADD, H. S. See ABBOTT, R. TUCKER. 335.
- LLANO, GEORGE A. A contribution to the lichen flora of Alaska. 196.
- LOOMIS, H. F., and DAVENPORT, DEMOREST. A luminescent new xystodesmid millipede from California. 270.
- MACNEIL, F. STEARNS. *Nucula austinclarki*, n. sp., a concentrically sculptured *Nucula* from the Lisbon formation of Alabama. 12.
- MILLER, ROBERT RUSH, and WINN, HOWARD ELLIOTT. Additions to the known fish fauna of Mexico: Three species and one subspecies from Sonora. 83.
- MITRINOVITCH, D. S. On an equation of Neményi and Truesdell. 129.
- MORRISON, J. P. E. Two new Western Atlantic species of pulmonate mollusks of the genus *Detracia* and two old ones (family Ellobiidae). 17.
- MORTON, C. V. A new fern of the genus *Danaea* from Colombia. 276.
- MUIR-WOOD, HELEN M. See COOPER, G. A. 195.
- NEUVONEN, K. J. See KRACEK, F. C. 373.
- NICOL, DAVID. A new species of glycymerid from the Philippines. 20.
- . Recent species of the cyrenoid pelecypod *Glossus*. 142.
- . Recent species of the veneroid pelecypod *Arctica*. 102.
- OTEIFA, BAKIR A. Effects of potassium nutrition and amount of inoculum on rate of reproduction of *Meloidogyne incognita*. 393.
- PATE, CHESTER H. Information theory. 245.
- PATTON, W. W., JR. See GRYS, GEORGE. 159.
- PAYNE, T. G. See GRYS, GEORGE. 159.
- PETTIBONE, MARIAN H. A new species of polychaete worm of the family Polynoidae from Point Barrow, Alaska. 44.
- PITELKA, FRANK A. Race names in the Central American jay, *Cyanolyca argentigula*. 113.
- PRAATT, HARRY D. *Ficalbia miniva* (Theobald) in South Indochina, with descriptions of the larva and pupa (Diptera: Culicidae). 300.
- REEDER, JOHN R. A new species of *Poa* from Peru. 295.
- REHDER, HARALD A., and ABBOTT, R. TUCKER. Two new Recent cone shells from the Western Atlantic (Conidae). 22.
- RIOUX, MARCEL. Some medical beliefs and practices of the contemporary Iroquois Longhouses of the Six Nations Reserve. 152.
- ROSS, HERBERT H. Phylogeny and biogeography of the caddisflies of the genera *Agapetus* and *Electragapetus* (Trichoptera: Rhyacophilidae). 347.
- SAVAGE, JAY M. Studies on the lizard family Xantusiidae, II: Geographical variation in *Xantusia riversiana* from the Channel Islands of California. 357.
- SCHAEFFER, CLAUDE E. Was the California condor known to the Blackfoot Indians? 181.
- SCHMITT, W. L. [Biographical Résumé, of Austin Hobart Clark.] 3.
- SCHROEDER, W. C. See BIGELOW, H. B. 110, 383.
- SCHULTZ, LEONARD P., and SIMÕES DE MENEZES, RUI. A new anchovy of the genus *Anchoviella* from the Poti and Parnaiba Rivers of Brazil. 235.
- . See also WELANDER, ARTHUR D. 107.
- SELANDER, R. K. See BEHLE, WILLIAM H. 364.
- SILBERSCHMIDT, K. See JENKINS, ANNA E. 66.
- SILSBEE, FRANCIS B. Measure for measure: Some problems and paradoxes of precision. 213.
- SIMÕES DE MENEZES, RUI. See SCHULTZ, LEONARD P. 235.
- SOHN, I. G. Check list of salinity tolerance of post-Paleozoic fossil Ostracoda. 64.
- SOLECKI, RALPH S., and HACKMAN, ROBERT J. Additional data on the Denbigh Flint Complex in northern Alaska. 85.
- SOULE, JOHN D. Two new species of incrusting ctenostomatous Bryozoa from the Pacific. 367.
- SPECK, FRANK G., and DEXTER, RALPH W. Utilization of animals and plants by the Micmac Indians of New Brunswick. 250.
- SPITZER, LYMAN, JR. The birth of stars from interstellar clouds. 309.
- STAINBROOK, MERRILL A. Substitution for the pre-occupied name *Hystericina*. 196.
- STRIMPLE, HARRELL L. New crinoids from the Pitkin of Oklahoma. 260.
- . New Desmoinesian crinoids. 191.
- . Notes on *Phanocrinus cylindricus* and description of new species of Chester crinoids. 291.
- TAWADA, SHINJUN. See WALKER, EGBERT H. 138.
- TIMM, R. W. A new species of marine nematode, *Thoracostoma magnificum*, with a note on possible "pigment cell" nuclei of the ocelli. 331.
- TIPTON, VERNON J. See TRAUB, ROBERT. 264.
- TRAGER, GEORGE L. Linguistic history and ethnologic history in the Southwest. 341.
- TRAUB, ROBERT, and TIPTON, VERNON J. *Jordanopsylla allredi*, a new genus and species of flea from Utah (Siphonaptera). 264.
- WALKER, EGBERT, and TAWADA, SHINJUN. A new species of *Portulaca* from Okinawa. 138.
- WEDEL, WALDO R. Notes on aboriginal pottery from Montana. 130.
- WELANDER, ARTHUR D., and SCHULTZ, LEONARD P. *Chromis atripectoralis*, a new damselfish from the tropical Pacific, closely related to *C. caeruleus*, family Pomacentridae. 107.
- WETMORE, ALEXANDER. Observations on the genera of the swans. 338.
- WILSON, MILDRED STRATTON. A new subgenus of *Diaptomus* (Copepoda: Calanoida), including an Asiatic species and a new species from Alaska. 168.
- . See also HUMES, ARTHUR G. 395.
- WINN, HOWARD ELLIOTT. See MILLER, ROBERT RUSH. 83.

## SUBJECT INDEX

- Archeology*. Additional data on the Denbigh Flint Complex in northern Alaska. RALPH S. SOLECKI and ROBERT J. HACKMAN. 85.
- A survey of new archeological sites in central Pataz, Peru. PHILIP D. CURTIN. 49.
- Notes on aboriginal pottery from Montana. WALDO R. WEDEL. 130.
- Astronomy*. The birth of stars from interstellar clouds. LYMAN SPITZER, JR. 309.
- Biography*. Biographical sketch and portrait of Austin Hobart Clark. 2-3.
- Botany*. A contribution to the lichen flora of Alaska. GEORGE A. LLANO. 196.
- A new fern of the genus *Danaea* from Colombia. C. V. MORTON. 276.
- A new species of *Poa* from Peru. JOHN R. REEDER. 295.
- A new species of *Portulaca* from Okinawa. EGBERT H. WALKER and SHINJUN TAWADA. 138.
- A study of the roots of *Pinus virginiana* in relation to certain Hymenomycetes suspected of being mycorrhizal. EDWARD HASKAYLO. 399.
- New or critical Euphorbiaceae from eastern Asia. HSÜAN KENG. 200.
- Peter Wilhelm Lund's pequi tree at Lagoa Santa and pilgrimages to his cemetery. ANNA E. JENKINS, A. A. BITANCOURT, K. SILBERSCHMIDT, and W. A. ARCHER. 66.
- Entomology*. A new genus and species of North American Olethreutidae (Lepidoptera: Lasiopyresinae). J. F. GATES CLARKE. 45.
- Dinoponera gigantea* (Perty), a vicious stinging ant. H. A. ALLARD. 88.
- Ficalbia minima* (Theobald) in South Indochina, with descriptions of the larva and pupa (Diptera: Culicidae). HARRY D. PRATT. 300.
- Jordanopsylla allredi*, a new genus and species of flea from Utah (Siphonaptera). ROBERT TRAUB and VERNON J. TIPTON. 264.
- New American chinch bugs (Hemiptera: Lygaeidae). CARL J. DRAKE. 319.
- New species of chrysomelid beetles of the genera *Trirhabda* and *Disonycha*. DORIS H. BLAKE. 324.
- New species of Gelechiidae from Argentina (Lepidoptera). J. F. GATES CLARKE. 140.
- New species of Olethreutidae from Argentina (Lepidoptera). J. F. GATES CLARKE. 296.
- Phylogeny and biogeography of the caddisflies of the genera *Agapetus* and *Electragapetus* (Trichoptera: Rhyacophilidae). HERBERT H. ROSS. 347.
- Ethnology*. Interesting animal foods, medicines, and omens of the eastern Indians, with comparisons to ancient European practices. LLOYD G. K. CARR. 229.
- Linguistic history and ethnologic history in the Southwest. GEORGE L. TRAGER. 341.
- Medicinal plants used by the Choctaw, Chickasaw, and Creek Indians in the early nineteenth century. T. N. CAMPBELL. 285.
- Some medical beliefs and practices of the contemporary Iroquois Longhouses of the Six Nations Reserve. MARCEL RIOUX. 152.
- Utilization of animals and plants by the Micmac Indians of New Brunswick. FRANK G. SPECK and RALPH W. DEXTER. 250.
- Was the California condor known to the Blackfoot Indians? CLAUDE E. SCHAEFFER. 181.
- Geology*. Present Cretaceous stratigraphic nomenclature of northern Alaska. GEORGE GRAY, W. W. PATTON, JR., and T. G. PAYNE. 159.
- Helminthology*. A new roundworm, *Nematodirus rufaevasitatis* (Nematoda: Trichostrongylidae), from domestic sheep, *Ovis aries*, in Wyoming. CHARLES G. DURBIN and RALPH F. HONESS. 179.
- Herpetology*. Studies of the lizard family Xantusiidae, II: Geographical variation in *Xantusia riversiana* from the Channel Islands of California. JAY M. SAVAGE. 357.
- Ichthyology*. Additions to the known fish fauna of Mexico: Three species and one subspecies from Sonora. ROBERT RUSH MILLER and HOWARD ELLIOTT WINN. 83.
- A new anchovy of the genus *Anchoviella* from the Poti and Parnaiba Rivers of Brazil. LEONARD P. SCHULTZ and RUI SIMÕES DE MENEZES. 235.
- A new genus and species of anacanthobatid skate from the Gulf of Mexico. HENRY B. BIGELOW and WILLIAM C. SCHROEDER. 110.
- Chromis atripectoralis*, a new damselfish from the tropical Pacific, closely related to *C. caeruleus*, family Pomacentridae. ARTHUR D. WELANDER and L. P. SCHULTZ. 107.
- Three new skates and a new chimaerid fish from the Gulf of Mexico. HENRY B. BIGELOW and WILLIAM C. SCHROEDER. 383.
- Malacology*. A new brackish-water gastropod from Texas (Amnicolidae: Littoridina). R. T. ABBOTT and H. S. LADD. 335.
- A new scaphopod mollusk, *Cadulus austinclarki*, from the Gulf of California. WILLIAM K. EMERSON. 24.
- A new species of glycymerid from the Philippines. DAVID NICOL. 20.
- More new urocoptid mollusks from Mexico. PAUL BARTSCH. 146.
- New stenothyrid gastropods from the Philippines (Rissoiidae). R. TUCKER ABBOTT. 14.
- Recent species of the cyrenoid pelecypod *Glossus*. DAVID NICOL. 142.
- Recent species of the veneroid pelecypod *Arctica*. DAVID NICOL. 102.
- Two new Recent cone shells from the Western Atlantic (Conidae). HARALD A. REHDER and R. TUCKER ABBOTT. 22.
- Two new Western Atlantic species of pulmonate mollusks of the genus *Detracia* and two old ones (family Ellobiidae). J. P. E. MORRISON. 17.
- Mammalogy*. Six new mammals from the state of San Luis Potasi, Mexico. WALTER W. DALQUEST. 361.
- Mathematics*. A problem in geometric probability. JEROME CORNFIELD and HAROLD W. CHALKLEY. 226.

- Mathematics.* Information theory. CHESTER H. PAGE. 25.  
On an equation of Neményi and Truesdell. D. S. MITRINOVITCH. 129.  
The theory of group representations. FRANCIS E. JOHNSTON. 117.
- Medicine.* Disaster and disease. V. H. HAAS. 277.
- Nematology.* Effects of potassium nutrition and amount of inoculum on rate of reproduction of *Meloidogyne incognita*. B. A. OTEIFA. 393.
- Ornithology.* Observations on the genera of the swans. ALEXANDER WETMORE. 338.  
Race names in the Central American jay, *Cyanolyca argentigula*. FRANK A. PITELKA. 113.  
The systematic relationships of the fox sparrows (*Passerella iliaca*) of the Wasatch Mountains, Utah, and the Great Basin. W. H. BEHLE and R. K. SELANDER. 364.
- Paleontology.* Brachiopod homonyms. G. ARTHUR COOPER and HELEN M. MUIR-WOOD. 195.  
Check list of salinity tolerance of post-Paleozoic fossil Ostracoda. I. G. SOHN. 64.  
New brachiopods from the Lower Cambrian of Virginia. G. ARTHUR COOPER. 4.  
New crinoids from the Pitkin of Oklahoma. HARRELL L. STRIMPLE. 260.  
New Desmoinesian crinoids. HARRELL L. STRIMPLE. 191.  
New Western Hemisphere occurrences of fossil selachians. DAVID H. DUNKLE. 344.  
Notes on *Phanocrinus cylindricus* and description of new species of Chester crinoids. HARRELL L. STRIMPLE. 291.  
*Nucula austinclarki*, n. sp., a concentrically sculptured *Nucula* from the Lisbon formation of Alabama. F. STEARNS MACNEIL. 12.  
Substitution for the preoccupied name *Hystericina*. MERRILL A. STAINBROOK. 196.  
Two new guide fossils from the Tallahatta formation of the Southeastern States. JULIA GARDNER. 8.
- Petrology.* Thermochemistry of mineral substances, I: A thermodynamic study of the stability of jadeite. F. C. KRACEK, K. J. NEUVONEN, and GORDON BURLEY. 373.
- Physics.* Measure for measure: Some problems and paradoxes of precision. F. B. SILSBEE. 213.  
The limitations of the principle of superposition: II. PAUL R. HEYL. 149.
- Zoology.* A luminescent new xystodesmid millipede from California. H. F. LOOMIS and DEMOREST DAVENPORT. 270.  
A new crayfish of the genus *Procambarus* from Louisiana, with a key to the species of the *Spiculifer* group. H. H. HOBBS, JR. 272.
- Zoology.* A new genus and species of notodelphoid copepod from Japan. PAUL L. ILLG. 30.  
A new species of marine nematode, *Thora-costoma magnificum*, with a note on possible "pigment cell" nuclei of the ocelli. R. W. TIMM. 331.  
A new species of polychaete worm of the family Polynoidae from Point Barrow, Alaska. MARIAN H. PETTIBONE. 44.  
A new subgenus of *Diaptomus* (Copepoda: Calanoida), including an Asiatic species and a new species from Alaska. MILDRED STRATTON WILSON. 168.  
A revision of the nomenclature of the Gorgoniidae (Coelenterata: Octocorallia), with an illustrated key to the genera. FREDERICK M. BAYER. 91.  
A second record of the polychaetous annelid *Potamethus elongatus* (Treadwell). E. and C. BERKELEY. 333.  
*Bostrichobranchnus digonas*, a new molluscid ascidian from Florida. D. P. ABBOTT. 302.  
Geographical distribution of the nemerteans of the northern coast of the Gulf of Mexico as compared with those of the southern coast of Florida, with descriptions of three new species. WESLEY R. COE. 328.  
New cleidogonid millipeds (Chordeumoidea). NELL B. CAUSEY. 78.  
New distributional records for two athecate hydroids, *Cordyphora lacustris* and *Candelabrum* sp., from the west coast of North America, with revisions of their nomenclature. CADET HAND and G. F. GWILLIAM. 206.  
Notes on the undescribed males of two species of Copepoda. S. KRISHNASWAMY. 75.  
The brittle-stars of the United States Navy Antarctic Expedition 1947-48. AUSTIN H. CLARK. 26.  
The diplopod family Campodesmidae (Polydesmida). RICHARD L. HOFFMAN. 209.  
The grass shrimps of the genus *Hippolyte* from the west coast of North America. FENNER A. CHACE, JR. 35.  
The last copepodid instar of *Diaptomus sanguineus* Forbes (Copepoda). ARTHUR G. HUMES and MILDRED S. WILSON. 395.  
The number of species of decapod and stomatopod Crustacea. F. A. CHACE, JR. 370.  
Two new primnoid corals of the subfamily Calyptrophorinae (Coelenterata: Octocorallia). FREDERICK M. BAYER. 40.  
Two new species of incrusting ctenostomatous Bryozoa from the Pacific. J. D. SOULE. 367.

## Officers of the Washington Academy of Sciences

*President*.....NATHAN R. SMITH, Plant Industry Station  
*President-elect*.....WALTER RAMBERG, National Bureau of Standards  
*Secretary*.....F. M. DEFANDORF, National Bureau of Standards  
*Treasurer*.....HOWARD S. RAPFLEYE, U. S. Coast and Geodetic Survey  
*Archivist*.....JOHN A. STEVENSON, Plant Industry Station  
*Custodian and Subscription Manager of Publications*  
 HAROLD A. REHDER, U. S. National Museum

*Vice-presidents Representing the Affiliated Societies:*  
 Philosophical Society of Washington.....EDWARD U. CONDON  
 Anthropological Society of Washington.....WALDO R. WEDEL  
 Biological Society of Washington.....  
 Chemical Society of Washington.....JOSEPH J. FAHEY  
 Entomological Society of Washington.....FREDERICK W. POOS  
 National Geographic Society.....ALEXANDER WETMORE  
 Geological Society of Washington.....LEASON H. ADAMS  
 Medical Society of the District of Columbia.....  
 Columbia Historical Society.....GILBERT GROSVENOR  
 Botanical Society of Washington.....E. H. WALKER  
 Washington Section, Society of American Foresters.....WILLIAM A. DAYTON  
 Washington Society of Engineers.....CLIFFORD A. BETTS  
 Washington Section, American Institute of Electrical Engineers  
 FRANCIS M. DEFANDORF  
 Washington Section, American Society of Mechanical Engineers.....RICHARD S. DILL  
 Helminthological Society of Washington.....L. A. SPINDLER  
 Washington Branch, Society of American Bacteriologists.....ANGUS M. GRIFFIN  
 Washington Post, Society of American Military Engineers.....HENRY W. HEMPLE  
 Washington Section, Institute of Radio Engineers.....HERBERT G. DORSEY  
 District of Columbia Section, American Society of Civil Engineers  
 MARTIN A. MASON

*Elected Members of the Board of Managers:*  
 To January 1952.....W. F. FOSHAG, C. L. GAZIN  
 To January 1953.....C. F. W. MUESEBECK\*, A. T. MCPHERSON  
 To January 1954.....SARA E. BRANHAM, MILTON HARRIS\*

*Board of Managers*.....All the above officers plus the Senior Editor  
*Board of Editors and Associate Editors*.....[See front cover]  
*Executive Committee*.....N. R. SMITH (chairman), WALTER RAMBERG, H. S. RAPFLEYE,  
 J. A. STEVENSON, F. M. DEFANDORF

*Committee on Membership*.....E. H. WALKER (chairman), M. S. ANDERSON, R. E.  
 BLACKWELDER, R. C. DUNCAN, G. T. FAUST, I. B. HANSEN, D. B. JONES, DOROTHY  
 NICKERSON, F. A. SMITH, HEINZ SPECHT, ALFRED WEISSLER  
*Committee on Meetings*.....MARGARET PITTMAN (chairman), NORMAN BEKKEDAHL,  
 W. R. CHAPLINE, D. J. DAVIS, F. B. SCHEETZ, H. W. WELLS

*Committee on Monographs:*  
 To January 1952.....J. R. SWALLEN (chairman), PAUL H. OEHSER  
 To January 1953.....R. W. IMLAY, P. W. OMAN  
 To January 1954.....S. F. BLAKE, F. C. KRACEK

*Committee on Awards for Scientific Achievement* (GEORGE P. WALTON, general chairman):  
 For the Biological Sciences.....G. H. COONS (chairman), J. E. FABER, JR.,  
 MYRNA F. JONES, F. W. POOS, J. R. SWALLEN  
 For the Engineering Sciences.....R. S. DILL (chairman), ARSHAM AMIRIKIAN,  
 J. W. MCBURNEY, FRANK NEUMANN, A. H. SCOTT  
 For the Physical Sciences.....G. P. WALTON (chairman), F. S. BRACKETT,  
 G. E. HOLM, C. J. HUMPHREYS, J. H. McMILLEN  
 For Teaching of Science.....B. D. VAN EVERA (chairman), R. P. BARNES,  
 F. E. FOX, T. KOPPANYI, M. H. MARTIN, A. T. MCPHERSON  
*Committee on Grants-in-aid for Research*.....L. E. YOCUM (chairman),  
 M. X. SULLIVAN, H. L. WHITTEMORE

*Committee on Policy and Planning:*  
 To January 1952.....J. I. HOFFMAN (chairman), M. A. MASON  
 To January 1953.....W. A. DAYTON, N. R. SMITH  
 To January 1954.....H. B. COLLINS, JR., W. W. RUBEY

*Committee on Encouragement of Science Talent:*  
 To January 1952.....M. A. MASON (chairman), A. T. MCPHERSON  
 To January 1953.....A. H. CLARK, F. L. MOHLER  
 To January 1954.....J. M. CALDWELL, W. L. SCHMITT

*Representative on Council of A. A. A. S.*.....F. M. SETZLER  
*Committee of Auditors*.....J. H. MARTIN (chairman), N. F. BRAATEN, W. J. YODEN  
*Committee of Tellers*.....W. G. BROMBACHER (chairman), A. R. MERZ, LOUISE M. RUSSELL

\* Appointed by Board to fill vacancy.

## CONTENTS

	Page
PETROLOGY.—Thermochemistry of mineral substances, I: A thermodynamic study of the stability of jadeite. F. C. KRACEK, K. J. NEUVONEN, and GORDON BURLEY.....	373
ICHTHYOLOGY.—Three new skates and a new chimaerid fish from the Gulf of Mexico. HENRY B. BIGELOW and WILLIAM C. SCHROEDER.	383
NEMATOLOGY.—Effects of potassium nutrition and amount of inoculum on rate of reproduction of <i>Meloidogyne incognita</i> . BAKIR A. OTEIFA.	393
ZOOLOGY.—The last copepodid instar of <i>Diaptomus sanguineus</i> Forbes (Copepoda). ARTHUR G. HUMES and MILDRED STRATTON WILSON	395
BOTANY.—A study of the roots of <i>Pinus virginiana</i> in relation to certain Hymenomycetes suspected of being mycorrhizal. EDWARD HASKAYLO.....	399
INDEX TO VOLUME 41.....	401







JOURNAL  
OF THE  
WASHINGTON ACADEMY  
OF SCIENCES

---

VOLUME 42, 1952

---

BOARD OF EDITORS

WILLIAM F. FOSHAG  
U.S. NATIONAL MUSEUM

J. P. E. MORRISON  
U.S. NATIONAL MUSEUM

JOHN C. EWERS  
U.S. NATIONAL MUSEUM

ASSOCIATE EDITORS

F. A. CHACE, JR.  
BIOLOGY

J. I. HOFFMAN  
CHEMISTRY

T. P. THAYER  
GEOLOGY

MIRIAM L. BOMHARD  
BOTANY

R. K. COOK  
PHYSICS AND MATHEMATICS

PHILIP DRUCKER  
ANTHROPOLOGY

C. W. SABROSKY  
ENTOMOLOGY

PUBLISHED MONTHLY  
BY THE  
WASHINGTON ACADEMY OF SCIENCES  
MOUNT ROYAL & GUILFORD AVES.  
BALTIMORE, MARYLAND

ACTUAL DATES OF PUBLICATION, VOLUME 42

No. 1, pp. 1-32, January 23, 1952

No. 2, pp. 33-64, February 20, 1952

No. 3, pp. 65-104, March 18, 1952

No. 4, pp. 105-136, April 24, 1952

No. 5, pp. 137-168, May 28, 1952

No. 6, pp. 169-208, June 30, 1952

No. 7, pp. 209-240, July 29, 1952

No. 8, pp. 241-272, August 19, 1952

No. 9, pp. 273-312, September 23, 1952

No. 10, pp. 313-344, October 20, 1952

No. 11, pp. 345-368, November 17, 1952

No. 12, pp. 369-396, December 17, 1952



# JOURNAL

OF THE

# WASHINGTON ACADEMY OF SCIENCES

### BOARD OF EDITORS

CHARLES DRECHSLER  
PLANT INDUSTRY STATION  
BELTSVILLE, MD.

WILLIAM F. FOSHAG  
U. S. NATIONAL MUSEUM

J. P. E. MORRISON  
U. S. NATIONAL MUSEUM

### ASSOCIATE EDITORS

J. C. EWERS  
ANTHROPOLOGY

C. W. SABROSKY  
ENTOMOLOGY

F. A. CHACE, JR.  
BIOLOGY

J. I. HOFFMAN  
CHEMISTRY

T. P. THAYER  
GEOLOGY

MIRIAM L. BOMHARD  
BOTANY

R. K. COOK  
PHYSICS AND MATHEMATICS

PUBLISHED MONTHLY  
BY THE  
WASHINGTON ACADEMY OF SCIENCES  
MOUNT ROYAL & GUILFORD AVES.  
BALTIMORE, MARYLAND

Entered as second class matter under the Act of August 24, 1912, at Baltimore, Md.  
Acceptance for mailing at a special rate of postage provided for in the Act of February 28, 1925  
Authorized February 17, 1949

## Journal of the Washington Academy of Sciences

This JOURNAL, the official organ of the Washington Academy of Sciences, publishes: (1) Short original papers, written or communicated by members of the Academy; (2) proceedings and programs of meetings of the Academy and affiliated societies; (3) notes of events connected with the scientific life of Washington. The JOURNAL is issued monthly. Volumes correspond to calendar years.

*Manuscripts* may be sent to any member of the Board of Editors. It is urgently requested that contributors consult the latest numbers of the JOURNAL and conform their manuscripts to the usage found there as regards arrangement of title, subheads, synonymies, footnotes, tables, bibliography, legends for illustrations, and other matter. Manuscripts should be typewritten, double-spaced, on good paper. Footnotes should be numbered serially in pencil and submitted on a separate sheet. The editors do not assume responsibility for the ideas expressed by the author, nor can they undertake to correct other than obvious minor errors.

*Illustrations* in excess of the equivalent (in cost) of one full-page halftone are to be paid for by the author.

*Proof*.—In order to facilitate prompt publication one proof will generally be sent to authors in or near Washington. It is urged that manuscript be submitted in final form; the editors will exercise due care in seeing that copy is followed.

*Unusual cost* of foreign, mathematical, and tabular material, as well as alterations made in the proof by the author, may be charged to the author.

*Author's Reprints*.—Reprints will be furnished in accordance with the following schedule of prices (approximate):

Copies	4 pp.	8 pp.	12 pp.	16 pp.	20 pp.	Covers
100	\$3.25	\$6.50	\$ 9.75	\$13.00	\$16.25	\$3.00
200	6.50	13.00	19.50	26.00	32.50	6.00
300	9.75	19.50	29.25	39.00	48.75	9.00
400	13.00	26.00	39.00	52.00	65.00	12.00

*Subscriptions* or requests for the purchase of back numbers or volumes of the JOURNAL or the PROCEEDINGS should be sent to HARALD A. REHDER, Custodian and Subscription Manager of Publications, U. S. National Museum, Washington 25, D. C.

*Subscription Rates* for the JOURNAL.—Per year . . . . . \$7.50

Price of back numbers and volumes:	Per Vol.	Per Number
Vol. 1 to vol. 10, incl.—not available.*	—	—
Vol. 11 to vol. 15, incl. (21 numbers per vol.)	\$10.00	\$0.70
Vol. 16 to vol. 22, incl. (21 numbers per vol.)	8.00	0.60
Vol. 23 to current vol. (12 numbers per vol.)	7.50	0.90

\* Limited number of complete sets of the JOURNAL (vol. 1 to vol. 41, incl.) available for sale to libraries at \$348.50.

MONOGRAPH No. 1, "The Parasitic Cuckoos of Africa," by Herbert Friedmann . . . \$4.50

PROCEEDINGS, vols. 1-13 (1899-1911) complete . . . . . \$25.00

Single volumes, unbound . . . . . 2.00

Single numbers . . . . . .25

*Missing Numbers* will be replaced without charge provided that claim is made to the Treasurer within 30 days after date of following issue.

*Remittances* should be made payable to "Washington Academy of Sciences" and addressed to the Treasurer, H. S. RAPPELBYE, 6712 Fourth Street, N.W., Washington 12, D.C.

*Exchanges*.—The Academy does not exchange its publications for those of other societies.

# JOURNAL OF THE WASHINGTON ACADEMY OF SCIENCES

VOLUME 42

January 1952

No. 1

ETHNOLOGY.—*Utilization of animals and plants by the Malecite Indians of New Brunswick.* FRANK G. SPECK, University of Pennsylvania, and RALPH W. DEXTER, Kent State University. (Communicated by John C. Ewers.)

An earlier paper (Speck and Dexter, 1951) described the utilization of animals and plants by the Micmac Indians of New Brunswick. The present report is a continuation of the same project in ethnology carried out in the summer of 1949 shortly before the death of Dr. Speck. Reference should be made to the previous publication for an explanation of this field study and the conditions under which these reports were prepared. Acknowledgment is again made to all those mentioned earlier in making it possible for the junior writer to complete these studies.

While traveling in Maine in September in 1949, we visited the Indian colony on Indian Island at Old Town. Several families, well known to Dr. Speck over many years time, were revisited. Information on our food investigation of the Eastern Woodland Indians was gathered largely from three members of the Malecite tribe who had formerly lived on the Malecite reservations of the St. John River Valley. They were Gabe Polchis, aged 65, who was born and raised in a wigwam on the banks of the St. John River in New Brunswick, and two younger men, Paul Sappier and Charles R. Paul. These informants, to whom we are greatly indebted, are familiar with the hunting and fishing activities and the utilization of natural resources in the St. John Valley. Again in this investigation, special attention was directed toward the use of native animals and plants for food or food procurement, with incidental attention to other multiple uses of these food resources. As before, an attempt has been made to synthesize original and published knowledge of an archeological, ethnological, and biological

nature so as to present an overview of the relations of these surviving aborigines to their natural environment. Like the Micmac and other groups of the Northeastern Indians, the Malecite lived largely on the harvest of wild resources. Many of their native practices have come down to the present day, in modified form, and others are still in the memory of the older Indians. Animals and their capture, especially, oriented the lives of these neolithic people who sought them for food, medicine, clothing, housing, and utensils. Animal life also forms the basis for much of their art, religion, folklore, and social organization.

Because Dr. Speck had previously learned or recorded many of the Malecite names for animals and plants on earlier field trips, only a few were taken down during this last one. Those are given in the text. It is unfortunate that our original intention of preparing a complete table of Malecite terms cannot be fulfilled. Transcriptions of Dr. Speck's linguistic notes were made by John Witthoft.—R.W.D.

## THE MALECITE INDIANS OF THE ST. JOHN RIVER VALLEY

In the valley of the St. John River there has long lived a group of American aborigines known as the Malecite. Early accounts designated these people as Etchemin or Maliseet. Those dwelling near the coast, with a somewhat different culture, have been given the special name of Passamaquoddy. They lived much like their neighbors, the Micmac of eastern New Brunswick and coastal Nova Scotia, which have been treated in the earlier report. The main

group of Malecite, however, have been river-bank dwellers, occupying the boundary between the Province of New Brunswick and the State of Maine. Chamberlain (1904) has offered a suggestion, not accepted by all, that the Malecite were an offshoot from the Penobscot tribe of Maine, which migrated northward and settled on the inland waters of northern Maine and western New Brunswick, especially along the St. John River. Here they called themselves "Wulastuk-wink," meaning "dwellers on the beautiful river." Today there still remain six reservations for these people along the St. John River at Oromocto, Devin (St. Mary), Kingsclear, Woodstock, Tobique Point, and Edmunston, named in order going upstream, where fishing and basket weaving are still the chief occupations. Our informants have visited or lived on all these reservations except the last two. In recent times there has been frequent intermarriage between the Malecite and Penobscot with a resulting fusion of their cultures. The Penobscot tribe has been monographed by Speck (1940).

Prehistoric culture of the Malecite, especially the coastal Passamaquoddy, has been the subject of archeological papers by Treat (1836), Baird (1882), Matthew (1884), Bailey (1887), and McIntosh (1909). Ethnological studies in this region by Maillard (1758), Barratt (1851), Flannery (1939, 1946), and Cooper (1946) have included information on protohistoric Malecite culture. Perhaps the best-known aspect of this culture is the folklore, much of which has been published by Jack (1895), Chamberlain (1898), Watson (1907), Mechling (1913, 1914), Stamp (1915), and Speck (1917). Just as in the case of the Micmac, animal life was the dominant theme of Malecite economic and social life. However, only the Passamaquoddy branch shared the dependency on marine resources which were so vital to the Micmac and other coastal tribes. Wissler (1924) has observed that "when a mode of culture evolves anywhere, it grows up around some natural resource and tends to spread to the distribution limits of that resource." The inland Malecite of the St. John Valley depended more upon fresh-water fishes, the birds and mammals of the river

bottomland, and upland game. They also developed agriculture to a greater degree. After contact with the white man, hunting gradually diminished and maize cultivation became of increasing importance. This led to even more of a sedentary existence. There is some evidence, however, that members of the inland bands at one time journeyed to the coast on the Bay of Fundy during the summer season to obtain shellfish and marine fishes, a portion of which was preserved and carried back for winter use.

Published records of shell heaps list the following marine animals which were gathered by the inhabitants and seasonal visitors along the coast line of southern New Brunswick:

- Pecten grandis*—Giant scallop
- Modiolus modiolus*—Horse mussel
- Mytilus edulis*—Blue mussel
- Mya arenaria*—Soft-shell clam
- Polinices heros*—Sand-collar snail
- Crepidula fornicata*—Boat shell
- Thais lapillus*—Rock snail
- Buccinum undatum*—Whelk
- Echinoidea—Sea-urchins
- Clupea harengus*—Herring
- Cottidae—Sculpins
- Gadus morhua*—Cod
- Elasmobranchii—Sharks
- Sea birds of various species

Undoubtedly this listing is very incomplete. Several small species of shells have also been reported, but they probably reached the refuse heaps accidentally. Land snails reported may have been hidden there by shrews as part of their storing activities, as similar finds in shell heaps of Massachusetts were explained by Speck and Dexter (1948). The occurrence of large quantities of the tests and spines of sea-urchins as found by Baird (1882) is unusual. Very little evidence is known for the utilization of these echinoderms on the North American coast except in the Aleutian Islands and adjacent areas where they were often the predominant food resource. Loomis and Young (1912) likewise reported sea-urchins from shell heaps they studied on the coast of Maine. Matthew (1884) raised the question that a sea-urchin found by him in an excavation may have been accidentally dropped there by a crow (or possibly by a gull?—author). Loomis and Young (*ibid.*) thought some of the snails they found might also have reached the shell heaps in the same way. Since the sea-urchins found by Baird were in one large mass in a single mound, they

may have served as an emergency food over a short period of time or advantage may have been taken of this animal form, commonly eaten in southern Europe, at a time when it was particularly abundant or easy to gather. Baird stated that they were cooked by being wrapped up in dried eelgrass (*Zostera marina*) and then burned.

The soft-shell clam was consumed in great quantities by the seashore dwellers of this region, some mounds consisting largely if not entirely of this species, but the quahog was not found by Baird in the mounds of eastern Maine and adjoining New Brunswick. Loomis and Young (1912), however, found the quahog in shell heaps on the coast of Maine. The oyster likewise was not encountered on Passamaquoddy shores by archeologists, although again Baird and Loomis and Young described a single large mound at Damariscotta, Maine, consisting almost entirely of this species. Today this bivalve is rarely found on the coast of Maine. Alternating layers of shells and of animal bones in the refuse heaps is interpreted by Baird (1882) as the result of summer gathering at the seashore alternating with winter hunting of game.

From the St. John River the following fishes were taken: Salmon, gaspereau (fresh-water herring or alewife), shad, striped bass, sturgeon, eel, smelt, and white perch. Barratt (1851) gave a brief account of salmon fishing with spears of rock maple. Striped bass and sturgeon were speared and, beside being used for food, the end of the nose was cut off and used as a rubber ball for play. Some fish were smoked, especially the salmon, gaspereau, shad, sturgeon, and eel. Decayed wood was used for the smoking. Eels were speared and were also taken in eel pots or traps (kadewi-galhi-gaon) made of splints. In fresh-water ponds and lakes, togue, pickerel, chubs, suckers, and shiners were fished. Another one called the gizzardfish was mentioned by our informants. The identity of this is not clear, but it might possibly refer to the gizzard shad. In recent times trout have been introduced into the waters of New Brunswick. Food, oil, and fertilizer were the products obtained through fishing.

Snapping turtles and their eggs were gathered for food. The reptile lore of these Northeastern Indians has been treated in an earlier paper (Speck, 1923). An interesting superstition from the Malecite is pointed out in that paper to the effect that a snakeskin worn about the head will ward off enemies.

As far as can be determined, river mussels and crayfish were not eaten although the fresh-water clams were used for bait. Bailey (1887) found wampum (or shell beads) manufactured from fresh-water clams.

The muskrat was one of the most important animals in Malecite culture. Both flesh and brains were used for food, the intestines were used in medicine, especially for diarrhea, and the hide was used for many purposes. Our informants described the cooking of muskrat by placing the whole carcass on coals. Jack (1895) relates that "the Malecite were known by other tribes of the Abenaki as 'the Mouskousoaks' or water rats either because, like these animals, they lived on the banks of the river or because they highly esteem the muskrat as food which they do at the present time, preferring its flesh beyond that of any other." The beaver and otter were other aquatic mammals of considerable value to these people. Beaver tail was considered a special delicacy, and the incisor teeth were made into knives. Ducks and geese and their eggs were taken in season for food. Ducks were cooked in a mud ball placed on coals. After the mud had dried and cracked, it was peeled off removing feathers and skin from the carcass. Our informants described the testing of duck eggs before using—fresh eggs sink in salt water, whereas those which are in process of development will float to the surface. Sandpipers, plovers, snipe, and woodcock were also eaten. The upland game pursued by the Malecite was essentially the same as that sought by the Micmac. The woodland caribou, moose, and white-tailed deer were the important ungulates that served as food and provided skins for clothing and shelter. Moose hide was used in making canoes and mocassins as well as clothing; the intestines, in cording snowshoes. The intestines were also cleaned, dried, and stored for winter food. Moose hair was used for embroidery on pouches and containers made from animal skins. The hides of all these large animals were used in making bags and containers. Sometimes the whole skin of one animal was adapted for that purpose. The black bear likewise was utilized for many purposes—flesh for food, hides and fur for clothing and shelter, intestines for bow strings, teeth and claws for beads and decoration, and bones for scrapers. Children ate the fat as a tidbit. Bears were captured chiefly by the deadfall trap (a'hazi-hi'gaon). Flesh of muskrat, beaver, caribou, moose, and deer was dried and smoked.

The snowshoe hare was trapped in the following manner. A pile of birch boughs was built to attract the animal. A fence was then constructed around this pile containing several openings through which the hares could pass to reach the source of food. Snare traps (abe'k'towa'gæn) were set in these openings to capture them as they passed through. Red and gray squirrels and woodchucks were also hunted. Tobacco pouches were made from the skins of woodchucks. Porcupine meat and quills were utilized as much by the Malecite as by the Micmac. Mr. Polchis said it was the easiest of the animals to kill. McIntosh (1909) found that designs on aboriginal pottery frequently resembled the porcupine quill ornamentation found on birch-bark vessels as well as that of spruce-root stitching. He believed these designs were suggested by the quill work on the bark vessels which long antedated the manufacture of pottery ware in this region. The raccoon, skunk, weasel, mink, pine marten, fisher, wolverine, and lynx were the common animals hunted for fur. The raccoon was also used for food, and the os baculum (penis bone) of this animal and the mink served as an ear pick for the Indians. Chamberlain (1884) listed both the Canada lynx and the bay lynx for New Brunswick and noted that pine marten was common at the time of his writing, but the fisher was rare. The woodland caribou was still common at that date, whereas the Virginia deer was uncommon but increasing in number. He also noted that the red squirrel was very abundant but the gray squirrel (mi'ko) was rare. The Canada ruffed grouse and spruce grouse, called fool hen by the Malecite, were among the most important forest birds. Fans were made from the tail feathers of these birds. The ring-necked pheasant has been introduced in recent times and the passenger pigeon, once so abundant, has become extinct. There is no indication that the American wild turkey ever extended this far in its range. Mr. Polchis called to our attention that hunters considered it bad luck to shoot an owl. Birdlore of the Northern Indians was the subject of an earlier paper by the senior author (Speck, 1921).

The hunting, fishing, and trapping devices of the Malecite were essentially the same as those employed by the Micmac. These included the harpoon (si'gawan), dip net (azahi'gæn), hook (pki'k-æn), spear (sapti-hi'gæn), leister (ni'gak), torch (pu'segwo'n), bow and arrow (ta'b nazaba'k<sup>w</sup>), traps (kolhi'gænæ), and others men-

tioned above. Here again the family hunting ground system regulated the taking of game and served to keep the Indian population in balance with the game populations (Cooper, 1939; Speck and Eiseley, 1939; Speck and Hadlock, 1946; Hallowell 1949).

Mr. Polchis mentioned eating black ants in the springtime for medicinal purposes. Only rarely did our informants mention the medical uses of animals and plants, and they were very reluctant to discuss the purposes for which certain native medicines were used. Mr. Polchis explained that it was tabu to discuss with members of the same sex medicinal properties of animals and plants for fear of losing the power of these medicants. Presumably one could discuss such matters with the opposite sex without fear of losing their value.

The coniferous trees, as abundant in Malecite territory as in that occupied by the Micmac, were commonly utilized. Roots for thread were obtained from the black and white spruce and balsam fir. Needles and branches of these same evergreens were used for pillows and bedding, while the pitch was used for waterproofing seams in the canoes, and in medicine. Bark of the white spruce was used for canoes and roofing the huts. Arrow shafts were made from tamarack. The bark of hemlock (k'ssius'k), tamarack, and yew served for medicine, and from the bark of hemlock a dye and tanning material was obtained. From white cedar (arbor vitae), wood for canoe slats and arrows was sought, and the bark was used in tanning hides. Of the deciduous trees, white or canoe birch was of greatest importance because of the uses of its bark for canoes, boxes, and containers of all kinds. Yellow birch was employed in the manufacture of sled and toboggan runners. The wood, stripped of the bark, was heated and used like the hot-water bottle of the white man. Brooms were also made from birch. Basket splints were made from brown ash, red maple, and white cedar, and the fiber from basswood was made into belts and ropes as well as for sewing birch bark. White ash was used for making boat frames and snowshoes. Elm (dje's-agænk<sup>w</sup>) bark was sometimes substituted for birch bark in the construction of bark canoes. Ironwoods (the hornbeams) were used for making bows and handles for utensils. Torch handles, paddles, and oars were made from the wood of sugar maple. Medicines were prepared from slippery elm, wild cherry, black cherry, sumac, alder, and the oaks. Willow bark was mixed with tobacco, and some-



times acorns mixed with dried willow bark was substituted for tobacco. Pipes were made from the wood of wild cherry, among other things. Even food was derived from the hardwoods. Maple syrup and sugar were tapped from the sugar-maple tree. Fruits were eaten from the wild plum, black cherry, choke cherry, and the sand cherry. Gorham (1943) reports the finding of charred plum pits found among the ashes of prehistoric campfires on old village sites, and clumps of plum trees (*Prunus nigra*) have been found still living on or near these village sites, relics of the new stone age. Since this plum is found in New Brunswick only in the vicinity of present or past habitations of man, Gorham has suggested that it might be a relict of aboriginal agriculture. Nuts were gathered from the hazelnut shrub and from butternut, beech, and oak trees. The acorns of the red, black, and white oak (wa'tei-lamās) were baked. All the woods, especially the hardwoods, were used as fuel. Two species of trees have been introduced from the Old World that are of special interest. The balm of Gilead (ewebi-bāk) is a source of medicine, especially salves, and of trap scents. The Lombardy poplar, however, was described as a cursed tree which brings bad luck. Land having the Lombardy poplar was said to be cursed, and the nearly verticle position of the branches is interpreted as a symbol asking for its forgiveness.

All the fruits and berries listed in the paper on the Micmac group were gathered by the Malecite, and, in addition, dewberry, bilberry (a'nkwudawāba'wi-mus), and mooseberry, the latter not recognized by the authors, were named by our

informants. Adney (1944) has made a special study of the native fruits and berries known to the Malecite. In spite of the wide variety of wild fruits eaten, the Indians were cautious about eating strange fruits and berries without consulting older people to determine whether they were suitable for food. Some fruits and berries were dried for winter use. The wild onion, the wild potato (ta'ki-damuk), and the roots of the bracken fern were harvested for food, and shoots of pokeberry and fiddlehead ferns were gathered for food. A number of introduced weeds have been added to the diet since the advent of colonization. Among these are the dandelion, wild mustard, pig weed, and lambs quarters. Wildrice, widely used among the eastern Indians, was harvested. Teas were prepared from wintergreen, Labrador tea, and the barks of many trees, but especially that of the yellow birch. In preparing teas a green stick was placed across the boiling vessel to prevent it from boiling over. Sweet flag, skunk-cabbage, and goldthread were used for medicines and sweet grass has been introduced for basket-making. Sphagnum mosses and cattail down served for absorbents and filling for mattresses.

American Indians lived close to nature. They had an intimate knowledge of animals and plants—where they lived, how they behaved, what use could be made of them, when and how they could be obtained. They had great respect for natural resources. Their stories and legends revolved about native animals particularly. Their whole lives were intricately woven into a pattern of plant-animal-man relationships.

TABLE 1.—ANIMALS AND PLANTS UTILIZED BY THE INLAND MALECITE INDIANS, CHIEFLY FOR FOOD OR FOOD PROCUREMENT

Scientific Classification	English Name	Scientific Classification	English Name
<b>INSECTA:</b>		<b>FISCHES (Continued):</b>	
Formicidae	Black ants	Cyprinidae	Shiners; minnows
<b>FISCHES:</b>		<i>Esox lucius</i>	Pike; pickerel
<i>Acipenser oxyrinchus</i>	Sturgeon	<i>Perca flavescens</i>	Yellow perch
<i>Anguilla bostoniensis</i>	Eel	<b>REPTILIA:</b>	
<i>Dorosoma cepedianum</i> ?	Gizzard shad; gizzardfish	<i>Chelydra serpentina</i>	Snapping turtle
<i>Pomolobus pseudoharengus</i>	Alewife; fresh-water herring; gaspereau	<b>AVES:</b>	
<i>Alosa sapidissima</i>	Shad	<i>Branta canadensis</i>	Canada goose
<i>Salmo salar</i>	Atlantic salmon	<i>Chen hyperborea</i>	Snow goose
<i>Cristiomer namaycush</i>	Togue; namaycush; lake trout	Anatinae; Nyrociniae	Surface-feeding and diving ducks
<i>Osmerus mordax</i>	Smelt	<i>Canachites canadensis</i>	Spruce grouse
<i>Roccus saszatilis</i>	Striped bass	<i>Bonasa umbellus</i>	Ruffed grouse
<i>Morone americana</i>	White perch; sea perch	<i>Phasianus colchicus</i>	Ringed-neck pheasant
Catostomidae	Suckers	Charadrioidae	Shorebirds
<i>Leucosomus corporalis</i>	Chub	<i>Philohela minor</i>	Woodcock

TABLE 1.—(Continued)

Scientific Classification	English Name	Scientific Classification	English Name
<b>AVES (Continued):</b>		<b>ANGIOSPERMAE (Continued):</b>	
<i>Capella delicata</i>	Wilson's snipe	<i>Allium</i> spp.	Wild onion
<i>Actitis macularia</i>	Spotted sandpiper	<i>Salix</i> spp.	Willows
Larinae	Gulls	<i>Populus glaucadensis</i>	Balm of Gilead
<i>Ectopistes migratorius</i>	Passenger pigeon	<i>Juglans cinerea</i>	Butternut
<b>MAMMALIA:</b>		<i>Corylus</i> sp.	Hazelnut
<i>Euarectos americanus</i>	Black bear	<i>Ostrya virginiana</i>	Hop-hornbeam; ironwood
<i>Procyon lotor</i>	Raccoon	<i>Carpinus caroliniana</i>	Hornbeam; ironwood
<i>Martes americana</i>	Marten	<i>Betula</i> spp.	Birches
<i>Martes pennanti</i>	Fisher	<i>Betula papyrifera</i>	Canoe birch; paper birch
<i>Mustela cicognani</i>	Weasel	<i>Alnus</i> spp.	Alder
<i>Mustela vison</i>	Mink	<i>Fagus grandifolia</i>	Beech
<i>Gulo luscus</i>	Wolverine	<i>Quercus</i> spp.	Oaks
<i>Lutra canadensis</i>	Otter	<i>Ulmus americana</i>	American elm
<i>Mephitis mephitis</i>	Skunk	<i>Chenopodium</i> sp.	Pigweed
<i>Lynx canadensis</i>	Lynx	<i>Phytolacca americana</i>	Poke; pigeonberry
<i>Marmota monax</i>	Woodchuck	<i>Coptis groenlandica</i>	Goldthread
<i>Sciurus hudsonicus</i>	Red squirrel	<i>Brassica</i> spp.	Mustard
<i>Sciurus carolinensis</i>	Gray squirrel	<i>Ribes</i> spp.	Currants; gooseberries
<i>Castor canadensis</i>	Beaver	<i>Crataegus</i> spp.	Hawthorn
<i>Ondatra zibethica</i>	Muskrat	<i>Fragaria virginiana</i>	Strawberry
<i>Erethizon dorsatum</i>	Porcupine	<i>Rubus</i> spp.	Raspberries; blackberries; dewberries
<i>Lepus americanus</i>	Showshoe rabbit; varying hare	<i>Prunus</i> spp.	Wild cherries; black cherries; beach plum; sand plum
<i>Odocoileus virginianus</i>	White-tailed deer; Virginia deer	<i>Apios americana</i>	Wild bean; groundnut
<i>Alces americana</i>	Moose	<i>Acer pennsylvanicum</i>	Moosewood; striped maple
<i>Rangifer caribou</i>	Woodland caribou	<i>Acer saccharum</i>	Sugar maple; rock maple
<b>BRYOPHYTA:</b>		<i>Acer rubrum</i>	Red maple
<i>Sphagnum</i> spp.	Sphagnum moss	<i>Vitis vulpina</i>	Wild grape; river-bank grape
<b>PTERIDOPHYTA:</b>		<i>Tilia americana</i>	Basswood
Filicinae	Ferns	<i>Cornus canadensis</i>	Bunchberry
<b>GYMNOSPERMAE:</b>		<i>Pyrola</i> sp.	Wintergreen
<i>Taxus canadensis</i>	Yew; ground hemlock	<i>Ledum groenlandicum</i>	Labrador tea
<i>Pinus strobus</i>	White pine	<i>Gaultheria procumbens</i>	Teaberry; checkerberry
<i>Larix laricina</i>	Tamarack	<i>Vaccinium</i> spp.	Blueberries; cranberries
<i>Picea glauca</i>	White spruce	<i>Frazinus americana</i>	White ash
<i>Picea mariana</i>	Black spruce	<i>Frazinus nigra</i>	Black ash; brown ash
<i>Abies balsamea</i>	Balsam fir	<i>Viburnum opulus</i>	Highbush cranberry
<i>Tsuga canadensis</i>	Hemlock	<i>Viburnum lentago</i>	Sheepberry
<i>Thuja occidentalis</i>	White cedar; arbor vitae	<i>Mitchella repens</i>	Partridgeberry
<i>Juniperus</i> spp.	Red cedar; juniper	<i>Sambucus canadensis</i> , S. <i>pubens</i>	Elderberries
<b>ANGIOSPERMAE:</b>		<i>Helianthus tuberosus</i>	Artichoke; wild potato
<i>Zosteria marina</i>	Eelgrass	<i>Taraxacum officinale</i>	Dandelion
<i>Zizania aquatica</i>	Wildrice		
<i>Hierochloë odorata</i>	Sweetgrass		
<i>Symplocarpus foetidus</i>	Skunk-cabbage		
<i>Acorus calamus</i>	Muskrat-root; sweet flag		

## LITERATURE CITED

- ADNEY, E. TAPPAN. *The Malecite Indians' names for native berries and fruits, and their meanings.* *Acadian Nat.* 1 (3): 103-110. 1944.
- BAILEY, L. W. *On the relics of the stone age in New Brunswick.* *Bull. Nat. Hist. Soc. New Brunswick*, no. 6 (art. 1): 3-16. 1887.
- BAIRD, S. F. *Notes on certain aboriginal shell mounds on the coast of New Brunswick and of New England.* *Proc. U. S. Nat. Mus.* 4: 292-297. 1882.
- BARRATT, JOSEPH. *The Indians of New England and the northeastern provinces:* 24 pp. 1851.
- CHAMBERLAIN, MONTAGUE. *Mammals of New Brunswick.* *Bull. Nat. Hist. Soc. New Brunswick* 1 (3), art. 4: 37-40. 1884.
- . *The origin of the Maliseets.* *New Brunswick Mag.* 1, 1898.
- . *The Indians in New Brunswick in Champlain's time.* *Acadiensis* 4: 280-295. 1904.
- COOPER, J. M. *Is the Algonquian family hunting ground system pre-Columbian?* *Amer. Anthrop.* 41: 66-90. 1939.
- . *The culture of the northeastern Indian hunters: A reconstructive interpretation.* In: "Man in Northeastern North America," Papers Robert S. Peabody Foundation for Archeology 3: 272-306. Ed. by F. Johnson. 1946.
- FLANNERY, REGINA. *An analysis of coastal Algonquian culture.* *Catholic Univ. Amer. Anthrop. Series* no. 7: 1-219. 1939.

- . *The culture of the northeastern Indian hunters: A descriptive survey*. In: "Man in Northeastern North America," Papers Robert S. Peabody Foundation for Archeology **3**: 263-271. Edited by F. Johnson. 1946.
- GORHAM, R. P. *The history of plum culture in New Brunswick*. *Acadian Nat.* **1** (2): 59-69. 1943.
- HALLOWELL, A. I. *The size of Algonkian hunting territories: A function of ecological adjustment*. *Amer. Anthrop.* **51** (1): 35-45. 1949.
- JACK, EDWARD. *Maliseet legends*. *Journ. Amer. Folk-lore* **8**: 193-208. 1895.
- LOOMIS, F. B., AND YOUNG, D. B. *On the shell heaps of Maine*. *Amer. Journ. Sci., ser. 4*, **34**: 17-42. 1912.
- MAILLARD, A. S. *Account of the customs and manners of the Micmakis and Maricheets*: 138 pp. London, 1758.
- MATTHEW, G. F. *Discoveries at a village of the stone age at Bocabec, N. B.* *Bull. Nat. Hist. Soc. New Brunswick* **1** (3): 5-29. 1884.
- MCINTOSH, WILLIAM. *Aboriginal pottery of New Brunswick*. *Bull. Nat. Hist. Soc. New Brunswick* **6** (2) art. 2: 110-120. 1909.
- MECHLING, W. H. *Maliseet tales*. *Journ. Amer. Folk-lore* **26**: 219-258. 1913.
- . *Malecite tales*. *Can. Geol. Surv. Mem.* **49** (*Anthrop. Series no. 4*): 133 pp. Ottawa, 1914.
- SPECK, FRANK G. *Malecite tales*. *Journ. Amer. Folk-lore* **30**: 479-485. 1917.
- . *Bird-lore of the northern Indians*. *Bull. Univ. Pennsylvania* **21** (18): 349-380. 1921.
- . *Reptile-lore of the northern Indians*. *Journ. Amer. Folk-lore* **36**: 273-280. 1923.
- . *Penobscot man*: 325 pp. 1940.
- SPECK, FRANK G., AND DEXTER, RALPH W. *Utilization of marine life by the Wampanoag Indians of Massachusetts*. *Journ. Washington Acad. Sci.* **38** (8): 257-265. 1948.
- . *Utilization of animals and plants by the Micmac Indians of New Brunswick*. *Journ. Washington Acad. Sci.* **41** (8): 250-259. 1951.
- SPECK, FRANK G., AND EISELEY, L. C. *Significance of hunting territory systems of the Algonkian in social theory*. *Amer. Anthrop.* **41**: 269-280. 1939.
- SPECK, FRANK G., AND HADLOCK, W. S. *A report on tribal boundaries and hunting areas of the Malecite Indian of New Brunswick*. *Amer. Anthrop.* **48**: 355-374. 1946.
- STAMP, HARLEY. *A Malecite tale: Adventures of Bakschinskewsk*. *Journ. Amer. Folk-lore* **28**: 243-248. 1915.
- TREAT, J. *Etchemins*. *Archaeologica Americana* **2**: 305-367. 1836.
- WATSON, L. W. *The origin of the Malecites*. *Journ. Amer. Folklore* **20**: 160. 1907.
- WISSLER, CLARK. *The relation of nature to man as illustrated by the N. A. Indian*. *Ecology* **5** (4): 311-318. 1924.

PALEONTOLOGY.—*Stratigraphic range of the ostracode genus Phanassymetria Roth*.<sup>1</sup> I. G. SOHN and JEAN M. BERDAN, U. S. Geological Survey. (Communicated by John B. Reeside.)

The genus *Phanassymetria* was established by Roth (1929, p. 358) for two species of ostracodes from the Haragan marl (Lower Devonian) of Oklahoma. In 1936 van Veen (1936, p. 177) discussed this genus and assigned to it two species from the Upper Cretaceous of Holland. As has been noted by Kellett (1943, pp. 626-627), this created a surprisingly long range for the genus, and because other species from intermediate periods have not been recorded, it appeared desirable to review the generic characters of both the Lower Devonian and the Cretaceous species. We have been fortunate in having van Veen's paratype material for study, as well as Roth's types from the Haragan marl, and have observed morphological differences between the Lower Devonian and the Cretaceous species. In this paper the genus *Phanassymetria* is

limited to those forms occurring in rocks of Silurian and Devonian age, and a new genus is established for the Cretaceous species.

We are grateful to Drs. G. A. Cooper and David Nicol, of the U. S. National Museum, for arranging the exchange of van Veen's paratype material through Dr. J. H. van Voorthuysen, Geologische Dienst, Haarlem, Holland, and for making available Roth's types. Dr. R. A. M. Schmidt, of the U. S. Geological Survey, prepared the radiographs used in illustrating this paper, and her cooperation is gratefully acknowledged. Mrs. Elinor Stromberg prepared the illustrations. We also wish to thank Dr. Kurt Rosenwald and Mrs. Severine Britt for assistance in translating the quoted portions of van Veen's discussion of *Phanassymetria* from the German.

#### MORPHOLOGY OF OSTRACODE SHELLS

The most recent discussion of the shell structure of ostracodes is that by Sylvester-

<sup>1</sup> Published by permission of the Director, U. S. Geological Survey.

Bradley (1941, pp. 1-33). The valves of living ostracodes are pierced at right angles to the surface by pores known as "normal pore canals," from which hairs protrude. In general, these pores are not recognizable on Paleozoic ostracodes, although they can be observed on many post-Paleozoic forms.

Swartz (1936, p. 581) described the early Paleozoic genus *Tubulibairdia* as characterized by "coarse tubular pores which open on the internal surface of the valves, but do not reach the exterior." The same type of pore occurs in the Paleozoic species of *Phanassymetria* (Fig. 1) and in other Paleozoic genera. If the tubules are normal pore canals they should be present in all the genera of a given faunule that contains specimens in which the tubules can be seen. We have examined material from several localities of Silurian and Devonian age and have observed that the tubules are restricted to a group of genera related to *Phanassymetria*. The tubules can be seen on the inside surface of well-preserved valves. In some cases they appear as perforations through the shell wall of abraded specimens. They may also be seen by transmitted light on wetted specimens of both complete carapaces and dissociated valves. Under some conditions of preservation it is necessary to make thin sections to determine the presence of the tubules. They show very plainly on radiographs of the valves. Examination of van Veen's paratype material from the Cretaceous of Holland fails to show any indication of these tubules, either with transmitted light or on the radiographs. The following translation of the discussion of the genus *Phanassymetria* by van Veen shows that she was not aware of the presence of the tubules in the early Paleozoic species:

This genus was established by Roth for two Lower Devonian ostracodes from America whose valves, as the name indicates, are distinctly asymmetrical. Their asymmetry consists in one valve being much larger than the other and overlapping it on all the margins.

Roth arbitrarily established the wider end as anterior, thus making the right valve larger. This orientation should very likely be reversed, making the left valve the larger, as is the usual case with ostracodes. This orientation is indicated also

by the fact that in *P. quadrupla* the posterior and not the anterior end varies considerably in width. Roth states that in both of his species the hinge of the valve which we consider as the left has a furrow and the right valve is flanged ["scharf"]. On the other hand, we believe that in our two species the opposite is the case, as is usual with other ostracodes.

Roth does not give generic characteristics, but describes in detail his two species. Bassler and Kellett (1934, p. 37) describe the genus in their Bibliographic Index of Paleozoic Ostracodes. They, however, base their description mainly on the genotype. They place this genus in the family Thlipsuridae. The following may be mentioned as the chief characteristics: The carapace is thick and strongly asymmetrical, since the left valve is much larger than the right one, and overlaps it on all the margins. The surface of the valves is smooth or punctate. Hinge margin straight, and hinge teeth absent.

Roth as well as we [van Veen] found two types of forms of this genus. We, therefore, originally concluded that his as well as our specimens represented a species exhibiting strong sexual dimorphism. The illustrations given by Roth do not contradict this assumption; *P. triseriata* would be the female and *P. quadrupla* the male. In order to investigate this problem a sample of Haragan marl from White Mound, Oklahoma, was obtained from Prof. R. W. Harris through the courtesy of Dr. Merle Israelsky to both of whom we express our sincere thanks. The sample contained a great number of complete carapaces and dissociated valves of the two species of *Phanassymetria* differentiated by Roth. We concluded that our assumption is most likely not correct because we believe that we are able to differentiate longer and shorter carapaces in both species ["Gattungen"] with a greater number of shorter ones.

Fossils of this genus were found only in the Lower Devonian of North America and in the Cretaceous of South Limburg, the former being much larger.

It may be mentioned that Bonnema (1932, p. 288; 1933, p. 25) was referring to this genus when he wrote "pot-with-lid."

As may be seen from the above discussion in addition to lacking tubules that are characteristic of *Phanassymetria*, the Cretaceous species differ in being smaller. It might be

considered as a possibility that the small size coupled with the absence of pores in the Cretaceous forms represents an atavistic reversion or a juvenile stage of the *Phanassymetria* stock. That this is not the case is shown by the presence of pores in a juvenile growth stage of *Phanassymetria*, which is about half the size of the adults, from the type locality at White Mound, Oklahoma. This juvenile specimen has a length of 0.5 mm as compared with a length of 0.4 mm for the Cretaceous specimens. It therefore appears that the resemblance between the lower Paleozoic and the Cretaceous species is due to homeomorphy rather than any genetic relationship. Even this resemblance is more apparent than real, however, as the "groove" on *P. foveata* van Veen, which is

supposed to resemble that on *P. triserrata* Roth, is actually a shallow subtriangular depression oblique to the hinge line (Fig. 5) rather than a groove open posteriorly and parallel to the hinge line as in the Paleozoic species. The thickness of the shell wall of the Paleozoic specimens appears to be proportionately greater than that of the Cretaceous specimens. In *P. afoveata* van Veen, no pit or groove is present, and the resemblance to the lower Paleozoic forms is in the general outline and in the alleged thickness of the shell walls. Considering these factors, and considering that no species assignable to *Phanassymetria* have been found in either the upper Paleozoic or the lower Mesozoic, it seems desirable to remove the Cretaceous species from the genus *Phanassymetria*.

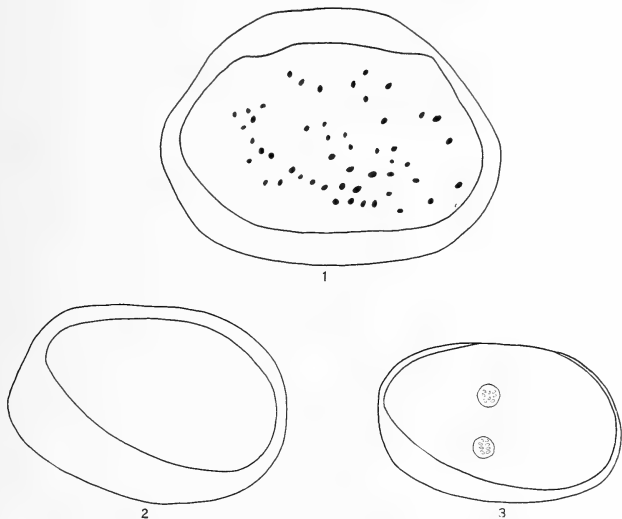

FIGS. 1-3.—1, *Phanassymetria* sp.: Left valve from the inside, camera-lucida drawing, approx.  $\times 66$ , showing the tubules. Marl beds of Haragan shale west of Clarita, Coal County, Okla., donated by Robert H. Stewart, U. S. Geological Survey, who obtained the sample from Prof. William Shideler, Miami University, Oxford, Ohio, U.S.N.M. no. 116454. 2, *Pseudophanassymetria foveata* (van Veen): Complete carapace, lateral view of right side, camera-lucida drawing from radiograph, approx.  $\times 113$ ; tubules not present. Van Veen's paratype material, Maestrichtian from South Limburg, Holland, U.S.N.M. no. 108231. 3, *Pseudophanassymetria? afoveata* (van Veen): Complete carapace, lateral view of right side, camera-lucida drawing from radiograph, approx.  $\times 113$ ; tubules not present. The specimen was tilted when the radiograph was made so that the muscle scar patterns, presumed to be located opposite each other, are projected on the plane of the film as two units. The upper pattern is interpreted to belong to the right valve, and the lower to the left valve. Van Veen's paratype material, Maestrichtian from South Limburg, Holland, U.S.N.M. no. 108232.

Family BAIRDIIDAE? Sars, 1887

**Pseudophanasymmetria** Sohn and Berdan, n. gen.

*Phanassymetria* (part) van Veen, Natuurhist. Maandblad, Jaarg. 25, no. 11-12: 177. 1936.

Genotype *P. foveata* (van Veen), *ibid.*: 177-178, pl. 10, figs. 16-22.

**Diagnosis.**—Markedly asymmetrical ostracodes with shells not penetrated by conspicuous large pores. Larger valve overlaps smaller on all margins. Hinge straight, simple, reported by van Veen to consist of a bar and groove. Both dorsal and lateral outlines subovate. Shell surface either smooth or punctate, and with a shallow depression on the posterodorsal part of the shell. Inner lamella not observed, probably absent.

**Discussion.**—The reasons for separating this genus from *Phanassymetria* have been cited above. Van Veen placed two Cretaceous species, *P. foveata* and *P. afoveata*, in *Phanassymetria*. Of these two, *P. foveata* has been selected as the type of the new genus. Van Veen (1936, p. 178) has stated that *P. foveata* and *P. afoveata* resemble each other in having the left valve much larger than the right and overlapping it on all margins, and also in having a small spine on the posterior margin of each valve. These spines are very small, and, according to van Veen, many of them are abraded. As such spines in many ostracode genera are not even of specific importance, the principal indication of relationship between the two species is the similarity in overlap. The species differ in the presence of surface sculpture in *P. foveata* as opposed to *P. afoveata*, and in a well-defined muscle scar in *P. afoveata*, which has not been observed in *P. foveata*. It is, therefore, possible that examination of additional material will show that the two species do not belong to the same genus. However, the material available to us, which consists of a complete carapace and one larger valve of each species, does not justify

the proposal of an additional genus. The species *afoveata* is provisionally referred to *Pseudophanasymmetria*. The following species appear similar to *Pseudophanasymmetria? afoveata*:

*Bairdia subglobosa* Bosquet, 1852, Memoires Couronnes et Memoires des Savants Etrangers publiés par l'Académie Royale des Sciences, des Lettres et des Beaux-arts de Belgique 24: 25, pl. 1, figs. 7a-d. Cretaceous to Miocene.—Bosquet, 1854, Mon. Crust. foss. Crétacé de Limburg: 65-66 (55-56), pl. 8, figs. 3a-d.

*Bairdia subglobosa* Méhes, 1911, Resultate der Wissenschaftlichen Erforschung des Balatonsees 3: pt. 6: 21, pl. 2, figs. 11-13, Triassic.

*Bairdia (?) problematica* Méhes, 1911 (= *Hungarella problematica* (Méhes)), Resultate der Wissenschaftlichen Erforschung des Balatonsees 3: pt. 6: 21, pl. 2, figs. 14-18, Triassic.

*Bairdia (?) problematica* var. *reniformis* Méhes, 1911 (= *Hungarella problematica* var. *reniformis* (Méhes)), Resultate der Wissenschaftlichen Erforschung des Balatonsees 3: pt. 6: 22-23, pl. 2, figs. 19-23, Triassic.

Further study may disclose that the listed species and *Pseudophanasymmetria? afoveata* belong to the same group, and in one or more genera. Bosquet's statement (1854, footnote, explanation to pl. 8) that the specimens described as *B. subglobosa* are young individuals of *B. subdeltoides* is probably not correct, because we have observed growth stages of species of Paleozoic *Bairdia* and of post-Paleozoic *Bairdoppilata* in which the younger stages have the same lateral and dorsal outlines as the adults. The Triassic species referred by Méhes to *Bairdia subglobosa* probably does not belong to it, and may require a new name.

**Pseudophanasymmetria foveata** (van Veen), 1936

Figs. 2, 4, 5

*Phanassymetria foveata* van Veen, Natuurhist. Maandblad, Jaarg. 25, no. 11-12: 177-178, pl. 10, figs. 16-22. 1936.



FIGS. 4-6.—4, 5, *Pseudophanasymmetria foveata* (van Veen): 4, Left valve from the inside, approx.  $\times 70$ ; anterior ventral portion broke in handling. Van Veen's paratype material, Maestrichtian from South Limburg, Holland, U.S.N.M. no. 108234; 5, complete carapace, dorsal view, approx.  $\times 70$ ; same specimen as shown in Fig. 2. 6, *Pseudophanasymmetria? afoveata* (van Veen). Left valve from the inside approx.  $\times 70$ . Van Veen's paratype material, Maestrichtian from South Limburg, Holland, U.S.N.M. no. 108233.

A translation of the original description follows:

This species is represented by 4 carapaces and 21 left valves. Right valves are absent, presumably because of their smaller size.

Carapace thick. Egg-shaped in lateral view, greatest height anterior to midlength. Anterior margin broadly rounded. Posterior margin somewhat truncated. Dorsal margin straight, ventral margin slightly convex. These two margins converge strongly backward, dorsal and ventral outline also egg-shaped, greatest width is behind midlength. Lengthwise very irregularly triangular, with greatest width below midheight so that the carapace is flattened out below.

It is very characteristic that the left valve has a sulcus [Grube] located on the outside in the back below the dorsal margin. The margins of the sulcus are elevated, except along dorsal margin. Strange to say, a similar sulcus is found in *P. triserrata* Roth, but there the elevation is lacking. The surface of the valves is finely punctate, with small dots that are arranged in rows. It is further characteristic that each valve has on its posterior a little spine, which, however, is often abraded. In *P. triserrata* such a spine is present on the dorsal surface of each valve.

This ostracode is present in Staring's third Bryozoa bed in the Jeker Valley, and in the first Bryozoa layer of Maestrichtian "d" at Bemelen.

Measurements (in millimeters):

	Greatest length	Greatest height	Convexity
Complete carapace	0.44	0.32	0.31
Left valve	0.41	0.23	—

The extremely small size of the specimens suggests that they possibly represent young growth stages. The original of van Veen's figs. 16-20, pl. 10, is here designated as the lectotype.

*Pseudophanassymetria? afoveata* (van Veen), 1936

Figs. 3, 6

*Phanassymetria afoveata* van Veen, *Natuurhist. Maandblad*, Jaarg. 25, no. 11-12: 178, pl. 10, figs. 23-30. 1936.

A translation of the original description follows:

This ostracode, too, belongs to the less common species, being represented by four complete carapaces, six left valves, and one right valve. The relationship of this ostracode with the previous one results from the fact that the left valve is much larger than the right and overlaps it all around, and that each valve bears a little spine on the posterior margin. It differs from the former by being smaller, less thick, more slender, and more cylindrical in shape. Moreover, the surface is not punctate. Furthermore, the groove on the posterior part is absent.

This species is found in Staring's third Bryozoa bed in the Jeker Valley and in the first Bryozoa bed at Bemelen.

Measurements (in millimeters):

	Greatest length	Greatest height	Convexity
Complete carapace	0.40	0.26	0.26
Left valve	0.41	0.26	—

The extremely small size of the specimens suggests that they possibly represent young growth stages. A complete carapace and two larger valves were available to us for study, but unfortunately one of the larger valves was destroyed during the process of obtaining radiographs, and a portion of the larger valve of the carapace was broken after a satisfactory radiograph was obtained. The radiograph of the carapace shows muscle scar patterns on both valves (Fig. 3). The pattern is circular and consists of eight discernible scars that differ in arrangement in the opposing valves. It is not known whether this asymmetry in arrangement of the individual muscle fibers is typical in ostracodes. The arrangement of the muscle scar pattern is similar to that of *Hungarella* Méhes (1911, p. 22) as figured by him for *Bairdia(?) problematica* Méhes, 1911, on pl. 2, fig. 16. The small scars that surround the central group in *Hungarella* are not discernible in *P. afoveata*. The original of van Veen's figs. 23-27, pl. 10, is hereby designated as the lectotype.

## REFERENCES

- BASSLER, R. S., and KELLETT, BETTY. *Bibliographic index of Paleozoic Ostracoda*. Geol. Soc. Amer. Spec. Pap. 1: 500 pp. 1934.
- BONNEMA, J. H. *Orientation of the carapaces of Paleozoic Ostracoda*. Journ. Pal. 6: 288-295. 1932.
- . *Die Orientierung der Schalen der paleozoischen Ostracoden*. Zeitschr. Geschiebeforsch. 9, pt. 1: 23-42. 1933.
- BOSQUET, J. *Monographie des Crustacés fossiles du terrain Crétacé du Duché de Limburg*. Mémoires de la Commission pour la description et la carte Géologique de la Neerland. 2: 137 pp., 10 pls. 1854.
- KELLETT, BETTY. *Permian ostracodes*. Journ. Pal. 17: 615-628, 1943.
- MÉHES, GYULA. *Über Trias-Ostrakoden aus dem Bakony*. Resultate der wissenschaftl. Erforschung des Balatonsees, Anhang, Paleont. der Umgebung des Balatonsees 3, pt. 6: 38 pp., 4 pls. 1911.
- ROTH, ROBERT. *Some ostracodes from the Haragan marl, Devonian, of Oklahoma*. Journ. Pal. 3: 327-372, pls. 35-38. 1929.
- SWARTZ, F. M. *Revision of the Primitiidae and Beyrichiidae, with new Ostracoda from the*

lower Devonian of Pennsylvania. Journ. Pal. 10: 541-586, pls. 78-89. 1936.

SYLVESTER-BRADLEY, P. C. *The shell structure of the Ostracoda and its application to their paleontological investigation.* Ann. Mag. Nat. Hist., ser. 11, 8: 1-33. 1941.

VAN VEEN, J. E. *Nachtrag zu der bis jetzt erschienenen Revision der Ostracoden der Maastrichter Tuffkreide und der Kunrader Korallenkalkes von Süd-Limburg.* Naturhist. Maandblad, Jaarg. 25, no. 11-12: 170-188, pls. 9-10. 1936.

PALEONTOLOGY.—*The arms of Polusocrinus.* HARRELL L. STRIMPLE, Bartlesville, Okla. (Communicated by Alfred R. Loeblich, Jr.)

Several months ago, Gregory Elias, of Gulf Oil Corporation, found a specimen of *Polusocrinus* Strimple (1951) with well-preserved arms attached. The specimen was obtained by the author through exchange and provides vital information for the study of ampelocrinids. The specimen was collected in the small excavation about half a mile due west of the school at Ochelata, Okla., in the Wann formation. This zone is also found at the hill, locally termed "The Mound," just west of the city limits of Bartlesville, Okla., where several specimens of the species have been collected by the author. Description is given below as *P. ochelataensis*, n. sp.

Genus *Polusocrinus* Strimple, 1951

There have been some questions raised as to the practicability of the genus *Polusocrinus*. One characteristic, which was not brought out by the author, is the lack of depth of the arm articulating facets found in the genus. In *Aesiocrinus magnificus* Miller and Gurely (1890), the genotype species, and in other typical representatives of that genus, the arm articulating facets attain a depth somewhat greater than the normal thickness of the RR. Typical species also have a shallow basal concavity. *Oklahomacrinus* Moore (1939) has comparable arm articulating facets, but the genus is characterized by extreme basal invagination, quite foreign to the convex base of *Polusocrinus*. The form described as *Moundocrinus osagensis* Strimple (1939) has the same type of arm articulating facets as *Polusocrinus* but the anal plate of that species is only faceted for the reception of a single tube plate, and the IBB circlet is smaller and downflared in attitude. In both *Polusocrinus* and *Aesiocrinus* the anal plate is followed by two tube plates.

With the knowledge afforded by the crown of *P. ochelataensis*, we are able to anticipate from

fourteen to sixteen arms in *Polusocrinus*. Most Pennsylvanian genera assigned to the Ampelocrinidae have only ten arms, and one, *Allosocrinus* Strimple (1949), has only five. *Exocrinus* Strimple (1949) has numerous arms, but the author contemplates removal of this genus from the ampelocrinids in the near future.

*Polusocrinus ochelataensis*, n. sp.

Figs. 1-8

Dorsal cup is full, semiglobular shaped. Five IBB form a large, pentagonal disk, which is shallowly concave about the columnar attachment but is mildly convex in its entirety. Five large BB are hexagonal except for the post. B, and are equally wide as long. Five RR are slightly wider than long and are pentagonal. Articulating facets slope inward and attain a length only 0.7 mm greater than the normal thickness of the RR. One large anal plate is present, resting evenly on the upper truncated extremity of the post. B. It extends only slightly above the upper extremity of the cup and attains its maximum width at the upper level of the cup. There is provision for the reception of two tube plates of equal size.

The entire crown is devoid of ornamentation and the sutures of the cup are not impressed. The column is pentagonal and the lumen is pentalobate. The tegmen has not been observed.

First bifurcation of the arms occurs on the low axillary second primibrachials in all rays. Subsequent branching is known in the left ray of all rami except the r. post. where preservation is not clear enough to be certain. The second secundibrachials are axillary in all left rays with the exception of the anterior where the first SBR is an unusually large axillary plate. The arms are uniserial and are well rounded, appearing not to have reposed in close contact. No branching has been observed in the right rays.

*Measurements in mm.*—As follows:



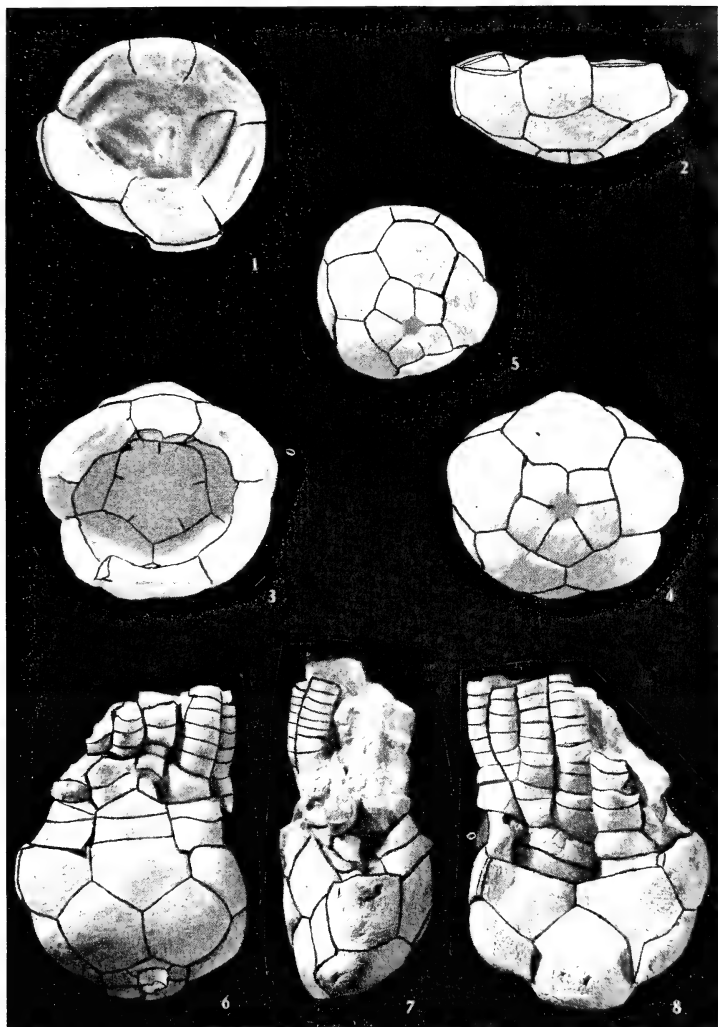

FIGS. 1-8.—*Polusocrinus ochelatacnis*, n. sp.: 1, 5, Paratype from summit,  $\times 2$ , and from base,  $\times 1.5$ ; 2-4, large paratype from posterior, summit, and base,  $\times 1.4$ ; 6-8, holotype from right anterior, posterior, and left anterior,  $\times 1.5$ .

	Holotype	Large paratype
Width of dorsal cup (max.).....	26.5*	29.2*
Height of dorsal cup (max.).....	14.2*	14.3*
Length of ant. R.....	8.7	10.0
Width of ant. R.....	13.2	15.7
Length of suture between RR.....	3.9	4.0
Length of arm articulating facet at suture.....	3.7	—
Normal thickness of RR.....	3.0	—
Length of r. ant. B.....	11.9	14.6
Width of r. ant. B.....	11.9	14.7
Length of suture between BB.....	6.3	5.6
Diameter of IBB circlet.....	12.2	14.2
Diameter of columnar scar.....	4.1†	3.5
Length of anal plate (max.).....	7.7	7.5
Width of anal plate (max.).....	7.9	9.0

\* Distorted.

† Proximal columnals.

*Remarks.*—*P. ochelataensis* has characteristics closely comparable to other described species referred to the genus. However, it has a more convex base and is the largest known species. The RR plates are wider and lower than those of *P. avanti* Strimple (1951), and the anal plate does not

extend so far above the summit of the cup. The BB plates of *P. rosa* Strimple (1951) are proportionately wider than those of the present species.

*Occurrence and horizon.*—The holotype is from a small excavation approximately one-half mile due west of Ochelata, and the paratypes are from the hill just west of the city limits of Bartlesville, Oklahoma; Wann formation, Ochelata group, Missouri series, Pennsylvanian.

*Types.*—To be deposited in the U. S. National Museum.

#### REFERENCES

- MILLER, S. A., AND GURLEY, W. F. E. Journ. Cincinnati Soc. Nat. Hist. **13**: 14. 1890.  
 MOORE, R. C. Denison Univ. Bull., Journ. Sci. Lab., **34**: 255-257. 1939.  
 STRIMPLE, H. L. Bull. Amer. Pal. **24**: 9-10, pl. 1, figs. 5, 6, 10. 1939.  
 ———. Bull. Amer. Pal. **32**: 9-10, 17-18. 1949.  
 ———. Bull. Amer. Pal. **33**: 24-26, pl. 5, figs. 4-6, 11. 1951.

ENTOMOLOGY.—*Phylogenetic studies of Franklinothrips (Thysanoptera: Aeolothripidae)*.<sup>1</sup> LEWIS J. STANNARD, JR. Illinois Natural History Survey, Urbana, Ill. (Communicated by Herbert Friedmann.)

The unusual aeolothripid genus *Franklinothrips* has been of particular interest to most thysanopterists. Whenever examples came to hand they were deemed worthy of special comment even when taxonomic considerations were not involved. Since at first it was not realized that dimorphic variation occurred in the antennal segments and heads of the sexes and since all but two of the seemingly new species were described from unique specimens, it is not too surprising that 11 species, 3 genera, and 1 family have been described or proposed for this small genus of six species.

Perhaps the most impressive feature of the *Franklinothrips* is the extremely elongated and slender third and fourth antennal segments, which bear elaborate sensoria (Figs. 1-3). For aeolothripids, their wings are narrow and the veins are exceptionally faint, so faint that some students formerly believed no cross veins were present. At least when dead, the head is often partially withdrawn into the prothorax giving this part of the

body a compact appearance. In nature they resemble ants somewhat.

In spite of the paucity of collections of these thrips, enough samples have been taken to indicate that they inhabit the warmer regions of the world and are confined to areas between the northern and southern latitudes of 35°. They are largely, if not entirely, predaceous, feeding on mites and insects including other thrips. The larvae spin flimsy pupal cocoons on the underside of leaves; there is but a single pupal stage in contrast to two or three pupal forms in all other thrips. Reijne (1920) published limited observations on their activities before and during the pupal stage, but details of the rest of their life history remain unknown. Occasionally males are attracted to lights but females have never been taken from this source.

*Franklinothrips* should not be confused with *Frankliniella*, another kind of thrips belonging to the family Thripidae.

Although only one type was available to me for study, borrowed identified specimens and freshly collected specimens of most of the other species were considered satisfactory reference material. Over 100 individuals of this genus were studied.

<sup>1</sup> This paper is a joint contribution of the Section of Faunistic Surveys and Insect Identification, Illinois Natural History Survey, and the Department of Entomology, University of Illinois.

I am sincerely grateful to Prof. Dr. Hermann Priesner, of Cairo, for the loan of male and female specimens of *F. megalops*; to C. F. W. Muesebeck and the late J. C. Crawford for permitting me to examine collections of *F. tenuicornis* and *F. vespiiformis* at the United States National Museum (USNM); to George Mack, of the Queensland Museum, for the loan of the holotype of *F. variegatus*; and to Dr. W. E. China, of the British Museum, for the information he has given me on the type specimen of *F. aureus*. Drs. S. F. Bailey, H. K. Gloyd, B. W. Benson, and E. Williams and E. C. Becker have aided me by their suggestions or by the presentation of specimens which have been placed in the collections of the Illinois Natural History Survey (INHS).

#### Genus *Franklinothrips* Back

*Franklinothrips* Back, Ent. News **23**: 75-77. Mailed Jan. 31, 1912. [Monotypic; genotype by original designation, *Aeolothrips vespiiformis* D. L. Crawford.]

*Mitothrips* Trybom, Ent. Tidskr. Arg. H. 3-4: 146-147. 1912. [Monotypic; genotype, *Mitothrips megalops* Trybom. New synonym, Bagnall (1913a); reestablished as full genus, Bagnall (1913b); resynonymized, Bagnall (1926).]

*Spathiothrips* Richter, Deutsch. Ent. Zeitschr. H. 1: 32. 1922. [Genotype by subsequent designation of Priesner (1949), *Spathiothrips bischoffi* Richter. New synonymy, Bagnall (1931).]

*Aeolothripoids* with extremely elongate third antennal segments having long linear sensoria subdivided or nearly subdivided by short subdermal rods; with head when closely fitted against the prothorax, forming with the prothorax a compact elliptical mass; with forepart of head not greatly extended beyond eyes; with but three segments in the maxillary palpus, although segment 2 bears faint markings indicating divisions; and with wings relatively narrow for the family. These antlike thrips have been found in tropical or subtropical regions of North and South America, in some of the adjacent islands including the West Indies, and in Africa and Australia.

Head round to oval in shape; ventral surface of eyes more prolonged posteriorly than dorsal surface; ocelli always present, although the fore ocellus is often smaller than the posterior ones; third antennal segment elongated, at least 10 times as long as broad; sensoria of the third and fourth antennal segments linear, more or less subdivided by fine strengthening subdermal

ridges, in the male these sensoria occupy the entire ventral and portions of the lateral areas of the third and fourth antennal segments; sensoria of the fifth, sixth, and seventh antennal segments peglike, extending free from their segments, the base of these sense cones oval; maxillary palpi 3-segmented, second segment of these palpi often with faint indications of about five subdivisions; labial palpi 4-segmented.

Prothorax with many small setae, no longer setae on the angles; mesosternellum (area posterior to the mesofurcal suture) fused with metasternum; all tarsi 2-segmented (see Crawford 1909, fig. 49D; not as in Back 1912, fig. 3); longitudinal and cross veins of forewings faint; wings similar to those of *Stomatothrips*.

Abdomen narrowly attached to thorax.

The remarkable ventral sensoria of the third and fourth antennal segments are found in no other kind of thrips. On both sides of the clear sensory area there appears to be a differentiated shelf extending longitudinally in a sinuate manner. This marginal area of a different texture than the granular dorsal surface possibly is covered by the sensorial membrane that extends over from the clear area. Since most of the ventral surface of the antennae is composed of the sensorial membrane, it is reasonable to suppose that the short rods extending from the shelf are for the purpose of strengthening the antennae to help keep it in a rigid shape. Proliferations of the dorsal integument toward the venter undoubtedly also serve to make the segment rigid. In Figs. 1 and 2, both dorsal views, the sensorial membranes are those areas on the lateral portions of the antennal segment; the shelf is depicted as small areas between the sublateral spines; and the dashes or short transverse lines represent the strengthening rods. These antennal segments were drawn from specimens which had been magnified by an oil immersion objective of a phase microscope. When the antennal segment of *megalops* was drawn (Fig. 3) I did not have access to a phase microscope, and I was unaware of the marginal shelf if it exists.

#### KEY TO ADULTS

(based in part on descriptions)

1. Females, sternum of abdominal segments 8 to 10 longitudinally divided, forming a cleft into which a sawlike ovipositor can be retracted. . . . . 2
- Males, sternum of abdominal segments 8 and 9 entire, not longitudinally divided. . . . . 7

2. Forewings with dark and light cross bands; some basal abdominal segments pale. . . . . 3  
Forewings with dark border around margins; abdomen uniformly dark. . . . . *lineatus* Hood
3. Antennal segment 4 largely, or entirely pale yellow. . . . . 4  
Antennal segment 4 brown. . . . . 6
4. Abdominal segment 4 completely dark brown, similar in color to segments 5 to 9; abdominal segments 1 to 3 pale in apical two-thirds. . . . . *tenuicornis* Hood  
Abdominal segment 4 mostly pale yellow, similar in color pattern to the preceding segments; abdominal segments 5 to 9 abruptly dark brown. . . . . 5
5. Antennal segment 4 with brown shading at apex; antennal segment 1 pale yellow. . . . . *megalops* Trybom  
Antennal segment 4 pale yellow without brown at apex; antennal segment 1 yellowish brown. . . . . *variegatus* Girault
6. Abdominal segment 10 black. *fulgidus* Hood  
Abdominal segment 10 yellowish. . . . . *vespiformis* Crawford
7. Forewings not continuously bordered around margins by dark band. . . . . 8  
Forewings continuously bordered around margins by a dark band. . . . . *lineatus* Hood
8. Antennal segments 3 and 4 dark brown, segment 3 as in Fig. 1; lateral ocelli farther apart from each other than the length of the diameter of a single ocellus, Fig. 7. *vespiformis* Crawford  
Antennal segments 3 and 4 light yellow brown, segment 3 as in Figs. 2 and 3; lateral ocelli closer to each other than the length of the diameter of a single ocellus, Fig. 8. . . . . 9
9. Ocellar setae minute, much shorter than the length of the 1st antennal segment, not reaching the anterior margin of the fore ocellus; antennal segments 1 and 2 pale, similar to segment 3; antennal segment 4 longer than segment 3. . . . . *megalops* Trybom  
Ocellar setae long, longer than the length of the 1st antennal segment, greatly extended beyond anterior margin of fore ocellus; antennal segments 1 and half of 2 abruptly brown; antennal segment 4 slightly shorter than segment 3. . . . . *tenuicornis* Hood

**Franklinothrips vespiformis** (Crawford)

*Aeolothrips vespiformis* D. L. Crawford, Pomona Coll. Journ. Ent. 1: 109-110, ♀. 1909 [Type locality: Managua, Nicaragua.]

*Franklinothrips vespiformis* (Crawford). Back, Ent. News 23: 75. 1912. [New combination.]

*Franklinothrips vespiformis* (Crawford), Williams, Trinidad and Tobago Bull. 17: 143-144. 1918. [Description of larva.]

*Franklinothrips vespiformis* (Crawford), Moulton, Rev. de Ent. 2: 464-465. 1932. [Description of ♂.]

Illustrations: Back, 1912; Crawford, D. L., 1909; Ebeling, 1950; Hood, 1915; Williams, 1918.

*Franklinothrips vespiformis*, the genotype and the oldest known species in the genus, is well illustrated in the literature and much described. It is the only *Franklinothrips* whose range extends northward into the boundaries of the United States. In the Nearctic region it occurs from southern Florida to southern California.

Some variation has been noted in the width of the forewing and in the color of the third antennal segment and wings, but these varying conditions have not been considered as yet in detail for interpretation of clinal or subspecific significance.

As a predator *vespiformis* is of benefit to growers of tropical fruits. Larvae have been observed by Ebeling (1950) feeding upon *Heliothrips haemorrhoidalis*. Reijne (1921) reports them as natural enemies of *Selenothrips rubrocinctus*. An excellent photograph of the feeding attitude was published in Ebeling's *Subtropical entomology*. Other hosts are red spider mites, *Tetranychus yotheri* McG.; leafhoppers, *Idona minuenta* (Ball); and white flies, *Trialeurodes floridensis* Q. (Moznette, 1920). Young and adults of *F. vespiformis* are often observed on leaves of herbs, shrubs, and trees. I have found them also on grass growing in roadside ditches in Chiapas, Mexico.

Pupal cocoons are spun on the under side of leaves (Moznette, 1920). These oval cocoons are composed of weak, loose mesh of silk several layers thick, surrounding the insect. Cocoon slides in the collection of the United States National Museum have within them either pupae or newly moulted females.

The distribution of *vespiformis* is from Brazil to southern United States, including islands of the West Indies, but apparently it is more numerous in Central America than in South America. It has been collected from the following places: Trinidad (Williams, 1918); Nicaragua (Crawford, 1909); USA: Florida (Back 1912), Texas (Hood, 1913), California (Moulton, 1929), Arizona (INHS); Panama (Hood, 1913); Cuba (Watson, 1923); Honduras (Watson and Hubbell, 1924); Mexico (INHS); St. Vincent Island, West Indies (Bagnall, 1917); Brazil (Moulton, 1932, 1938); Surinam (Reijne, 1920).

**Franklinothrips fulgidus** Hood

*Franklinothrips fulgidus* Hood, Rev. de Ent. 20: 8-9, ♀. 1949. [Type locality: Petropolis, R. J., Brazil.]

Illustrations: Hood, 1949.



VESPIFORMIS

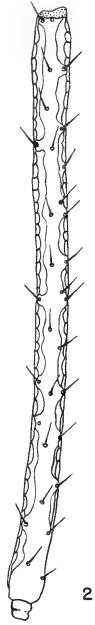

TENUICORNIS

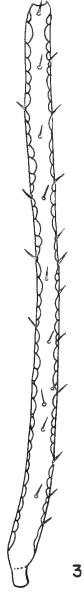

MEGALOPS



ERYTHROTHRIPS  
ARIZONAE



STOMATOTHRIPS  
FLAVUS



FRANKLINOTHRIPS  
VESPIFORMIS

FIGS. 1-6.—1-3, *Frankliniopsis*, males, third antennal segments, dorsal aspect; 4-6, Aeolothripidae, females, fourth antennal segments, dorsal aspect.

Possibly *fulgidus* is most closely related to *vespiformis*. In coloration *fulgidus* has no basal dark cross bands on abdominal segments two and three and the tenth abdominal segment is dark. In contrast *vespiformis* has dark cross bands on the basal parts of abdominal segments two and three and the tenth abdominal segment is pale yellow.

This species is known from Brazil by two females.

#### **Franklinothrips lineatus Hood**

*Franklinothrips lineatus* Hood, Rev. de Ent. **20**: 4-6, ♂, ♀, 1949. [Type locality: Nova Teutonia, Brazil.]

Illustrations: Hood, 1949.

This species is the only member of the genus with blackish-bordered wings without cross bands, although the male has faint indications of cross banding in addition to the black border. It is also the only species that is not bicolored on the abdomen. Instead, at least in the female, the abdomen is uniformly dark brown in pigment.

Nothing at all is known of its habits. It has been discovered just recently from Brazil.

#### **Franklinothrips megalops (Trybom)**

*Mitothrips megalops* Trybom, Ent. Tidskr. Arg. **33** H. 3-4: 147-151, ♂, 1912. [Type locality: Kibwezi, British East Africa.]

*Franklinothrips megalops* (Trybom), Bagnall, Trans. 2d Ent. Congress (1912): 397. 1913. [New combination.]

*Mitothrips megalops* Trybom, Bagnall, Journ. Econ. Biol. **8**: 157-158. 1913 [Reconsidered, transferred from *Franklinothrips* back to original *Mitothrips*.]

*Franklinothrips myrmicaeformis* Zanon, Atti Pontifica Acad. Sci. Nouvi Lincei **77** (separate): 4-9, ♀. 1924. [Type locality: Bengasi, Libya. New synonym, Bagnall, 1927.]

*Franklinothrips megalops* (Trybom), Bagnall, Ann. Mag. Nat. Hist. **17**: 170. 1926. [Reconsidered, combined again with *Franklinothrips*.]

*Spathiothrips bischoffi* Richter, Deutsch Ent. Zeitschr. H. 1: 33, ♀. 1928. [Type locality: Kwarangiva, German East Africa. New synonymy, Bagnall, 1931.]

*Franklinothrips aureus* Moulton, Ann. Mag. Nat. Hist. **17**: 496-497, ♂ (erroneously given as ♀ in original description). 1936. [New synonymy.]

Illustrations: Richter, 1928; Trybom, 1912; Zanon, 1924.

This African species has been illustrated, described, and discussed frequently under several names. Bagnall (1915, 1926) and Richter (1928) were the only two thysanopterists who possibly recognized its close relationship to *F. tenuicornis*,

a South American species. While neither of these authors always used the name *tenuicornis*, or even necessarily the name *megalops*, they did place the two entities together to form a group distinct from *vespiformis*. The recent discovery of the male of *tenuicornis* now permits, with reasonable certainty, the conclusions that both of these species, *megalops* and *tenuicornis*, are very similar in all respects and both are more different from *vespiformis* than either is from the other.

Possibly the Australian *variegatus*, another member of the *megalops-tenuicornis* group, is the closest relative of *megalops*. However, since there are no known males of *variegatus* for comparative studies and since the single type specimen of *variegatus* is probably deformed, the exact relationship of *megalops* and *variegatus* cannot be determined.

My suspicion that *aureus* was based on a male specimen rather than a female as stated by Moulton (1936) was substantiated by Dr. China, who examined the unique type for me. Dr. China stated that the type slide had been labelled " = ♂ of *F. megalops*" by Mr. F. Laing.

The preceding key and the discussion under the section of phylogeny present points for the recognition of this species as well as evidence used in placing it near *tenuicornis* in the genus.

Measurements of the antennae given in several of the descriptions and measurements I have made indicate some regional variation. If all the measurements and statements are correct, the fourth antennal segment of the male varies from about two times as long as the last five segments combined to nearly three times the length of the last five segments. Average antennal segment lengths of females of *megalops* and *tenuicornis* are similar to each other, but both differ considerably from their respective males.

Like other *Franklinothrips* whose habits have been observed, *megalops* is also predatory. Dr. Ebeling has called my attention to an article written by Avidov and Ben-Haim in which they report *megalops* (under the name *myrmicaeformis*) as being natural enemies of *Heliothrips haemorrhoidalis* and *Retithrips syriacus* in Israel.

Collections of *megalops* have been made from Kibwezi, British East Africa (Trybom, 1912); Bengasi, Libya (Zanon, 1924); German East Africa (Richter, 1928); Mossel Bay, Cape Province, South Africa (Bagnall, 1927, and Moulton, 1930); and Paoli, Italian Somaliland (material borrowed from H. Priesner).

**Franklinothrips tenuicornis Hood**

*Franklinothrips tenuicornis* Hood, Ent. News **26**: 164-165, ♀. Mailed Mar. 31, 1915. [Type locality: Moro Island, Panama.]

*Mitrothrips petulans* Bagnall, Linn. Soc. Journ. **32**: 496-498, ♀. Sept. 1915. [Type locality: Sangre Grande, Trinidad. New synonymy, Bagnall, 1926.]

*Franklinothrips tenuicornis* Hood, Williams, Trinidad and Tabago Bull. **17**: 1440. 1918. [Description of larvae.]

*Spathiiothrips petulans* (Bagnall), Richter, Deutsch Ent. Zeitschr. H. **1**: 33-37. 1928. [New combination of synonym.]

*Franklinothrips petulans* (Bagnall), Moulton, Rev. de Ent. **2**: 465. 1932. [New combination of synonym.]

Illustrations: Bagnall, 1915; Hood, 1915; Reijne, 1920.

Contrary to the contention made by Hood (1915) *tenuicornis* is most closely allied morphologically, character by character, to *megalops* rather than to *vespiformis*. Comparisons of these species are made in the section on phylogeny. Shared in common with *vespiformis* are areas of the range of *tenuicornis* since both species occur in Trinidad, Surinam, and Panama, and possibly in other parts of South America. Unlike *vespiformis*, *tenuicornis* does not extend into Central America.

Description of male: Length distended about 1.7 mm. Body generally brown with much red to purplish-red subintegumental pigments; abdominal segments 2 and 3 and tibiae, pale yellow; apices of femora light brownish yellow; tip of abdomen orange-yellow; antennal segments 1, base of 2, and all of 5 to 7 brown concolorous with head; tip of antennal segment 2, and all of segments 3 and 4 light brownish yellow; ocellar pigments crimson; forewings with three brown bands, one near base, one just beyond the middle and one at the tip of the wing; forewing scale possibly brownish.

Head oval with large eyes and ocelli, with long interocellar setae, as in Fig. 8; antennal segments 3 and 4 with elaborate sensoria, finely divided by numerous ridges as in Fig. 2; segment 3 slightly longer than segment 4. Maxillary palps 3-segmented with almost no indications of subdivision marks in the second segment.

Prothorax slightly narrower than head width.

Abdomen unadorned by clasperlike processes as found in some males of *Aeolothrips*.

Described from a male collected in a light trap at Madden Dam, Panama Canal Zone, on February 1, 1946, by Dr. Eliot Williams.

Both C. B. Williams (1918) and Reijne (1920), have noted that the habits of *tenuicornis* are similar to those of *vespiformis*. Larvae of *tenuicornis* actually have been observed feeding on *Selenothrips rubrocinctus*, the Cacao thrips. An interesting account of the cocoon making activities of *tenuicornis* was given by Reijne in 1920. According to this author, the prepupal stage does not occur; instead the larva passes directly into the pupal form.

*F. tenuicornis* has been found in the following regions: Trinidad (Bagnall, 1915; Williams, 1918); Panama (Hood, 1915); Peru (USNM); Surinam (Reijne, 1920); Venezuela (Moulton, 1932); Brazil (Moulton, 1932, 1938).

**Franklinothrips variegatus Girault**

*Franklinothrips variegatus* Girault, Brisbane, Private publication, ♀. 1927. [Type locality: Brigalow, Jandowae, Queensland, Australia.]

In coloration and in structure *variegatus*, (Fig. 9) is most similar to the African *megalops*. Unlike *megalops* the legs of *variegatus* are darker; the first antennal segment is darker, lightly shaded with brown; the fourth antennal segment is entirely light yellow, nearly white, without brown at the apex; and the fourth antennal segment is slightly longer in proportion to the third segment in the female.

Both antennal segments are detached beyond the third segment in the type slide. The detached portion of one antenna lies to the side under the cover slip; the remainder of the other antenna is missing. Most probably the present portion is of a deformed antenna because segments 7 and 8 are completely fused (Fig. 10). Such deformities are not uncommon in the Thysanoptera. It seems unwise, therefore, to characterise this species as "having each antenna with but eight segments" on the basis of this one fragment.

Girault, in his original description, stated: "Antennal 3 elongate, 5-7½ + 4 which is shorter than 3." By this remark Girault most likely meant that the length of segments 5, 6, and 7 together is 1½ times longer than the segment 4 and that segment 4 is shorter than segment 3. To arrive at such a conclusion Girault must have considered the fused seventh and eighth segment and the small ninth segment as one, the seventh segment. Actually the suture setting off the ninth segment is difficult to see in Girault's slide preparation. By this interpretation, even though incorrect, the combined length of segments 5, 6, and 7 is 1½ times longer than the fourth. Some

time later Kelly and Mayne (1934) reworded Girault's remarks to state that the combined length of segments 5, 6, and 7 is equal to half the length of 4. Their rewording is in error, not only

in the interpretation of Girault's meaning but also in fact. The combined length of segments 5, 6, and 7, whether the seventh is the "deformed" fused seventh and eighth, or the morphological

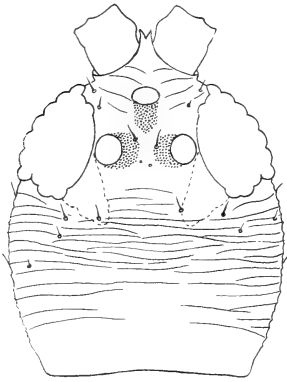

VESPIFORMIS

7

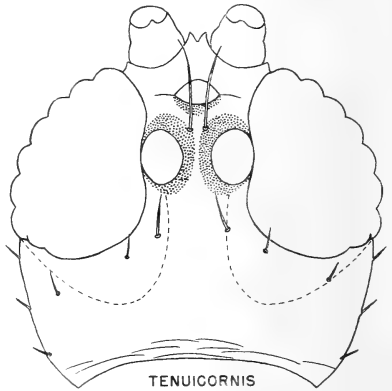

TENUICORNIS

8

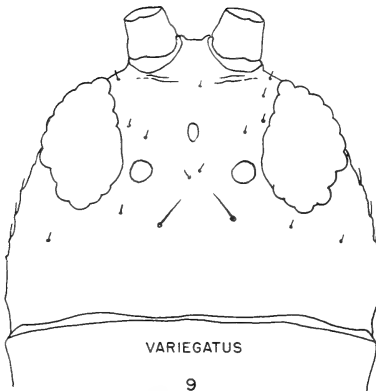

VARIEGATUS

9

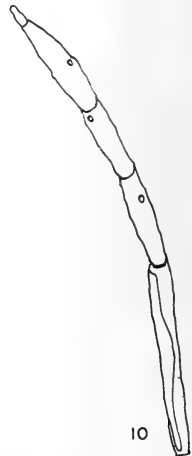

10

VARIEGATUS

FIGS. 7-10.—7, 8, *Frankliniopsis*, males, heads, dorsal aspect; 9, 10, *Frankliniopsis variegatus*: 9, Head, dorsal aspect, holotype; 10, outline of "deformed" antennal portion, holotype.



seventh segment, measured to the fusion line, is either slightly longer than the fourth, or very much longer than the fourth segment.

Although described nearly a quarter century ago, presumably the type specimen, captured February 17, 1924, remains the only known representative of this species. It is the sole species of *Franklinothrips* in Australia.

#### PHYLOGENY

Guide points for the initial plotting of the phylogeny are more apparent in certain male structures in this genus. Variations in the shape of the third and fourth antennal segments and their sensorial areas and the head outline are more markedly different between the males than between the females. Since these differences range from one type to another, a progression can be set up using any extreme as the starting place. After these characters have been correlated to establish the progressive trend, relationships of both ends of the trend (most like the prototype or most divergent) can be determined by associating these ends with the rest of the family. Such a procedure was followed in determining what could be surmised of the phylogeny of *Franklinothrips*. Because two of the species are unknown in the male sex, only *megalops*, *tenuicornis*, *vespiformis*, and *lineatus* were considered for exact relationships.

Figs. 1 and 2 of the third antennal segment illustrate the greatest divergence in antennal types. The fourth segment resembles the third except that it differs in size. In *vespiformis* the third segment is shorter and wider than in its congeners, and the sensorial membrane is less subdivided by ridges. On the other hand, *tenuicornis* and *megalops*, both similar to each other, have a more slender and longer third and fourth segment, and the sensoria have many numerous ridges subdividing them. Possibly near the latter extreme is the antennal type found in *lineatus*. Although Hood in 1949, called the sensoria of *lineatus* colorless and reticulated ventral and lateral areas, his drawing of the fourth antennal segment shows that this colorless region is that part of the antennae that is referred to here as a sensorium. In some respects the sensoria of *lineatus* are more like *tenuicornis* and *megalops* in the

fourth segment and presumably also in the third segment.

Two types of head outlines exist in the males. The oval-shaped head with relatively smaller compound eyes, as in *vespiformis* (Fig. 7), differs from the round head and relatively larger compound eyes of *megalops* and *tenuicornis* (Fig. 8). Again, compared with Hood's illustrations, the head of *lineatus* appears to be intermediate between the round and oval types. The *lineatus* head is oval but the eyes are proportionately larger than those of *vespiformis*, approaching more closely the eye shapes found in *megalops* and *tenuicornis*.

By so sorting these several characteristics and correlating them, the empirical phylogenetic tree shown in Fig. 11, is suggested.

The species *fulgidus* and *variegatus* are placed on this tree solely on the basis of color similarities.

Whether the genus originated as a form similar to *vespiformis* or instead similar to *megalops*, or even by a form intermediate to these two, possibly like *lineatus*, is the next aspect to be considered. To attempt determination of this starting point it is necessary to examine the family Aeolothripidae of which *Franklinothrips* is a part.

When the extremes of some characteristics of many species of the family Aeolothripidae were established and intermediate types plotted between the extremes, a sort of rectilinear progression was noted. A very

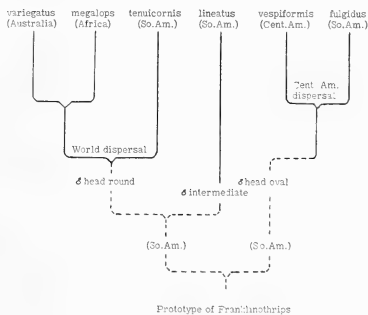

FIG. 11.—Family tree of the genus *Franklinothrips* showing possible historical distribution.

gradual progression occurs from short to long third and fourth antennal segments, from small circular to elongate linear third and fourth antennal sensoria, from pupation in the soil to pupation on leaves, and from flower inhabitants to roving predators.

*Franklinothrips* finds its place in this scheme at one extreme end of its family. This genus represents that end of the progression having the longest third and fourth antennal segments, having the most elaborate elongate sensoria on these two segments, besides being predators and using leaves for pupation sites.

The species *teuicornis* and *megalops*, because they possess the longest third and fourth antennal segments with the most subdivisions in the sensoria of these segments, would be the most extreme forms of the genus and of the family. Therefore, it is reasonable to presume that either *lineatus* or *vespiformis* both having less elaborately formed antennae are closer to the prototype than is the *megalops* group. Because I have not had the opportunity to examine a male of *lineatus* I am unable to continue the analysis to decide whether *Franklinothrips* arose from a *lineatus*-like species or a *vespiformis*-like species. However, it seems probable that both *lineatus* and *vespiformis* are specialized themselves and that the ancestor of the genus, while near the latter two species, was even more primitive. This ancestor could have been a *Stomatothrips* derivative.

Development of the peculiar sensoria of the *Franklinothrips* can be traced from clues derived from living forms. Figs. 4, 5, and 6 show the sensoria of females in three genera. A progression goes from the smaller linear type in *Erythrothrips* to the more elongated sensoria of *Stomatothrips* to the extremely elongated form in *Franklinothrips*. Faint indications of sensorial subdivisions first appear in *Stomatothrips*. A broadening of the sensoria to cover the entire surface of the third and fourth antennal segments has evolved in the male sex only of the *Franklinothrips* whereas the *Franklinothrips* female has preserved the *Stomatothrips* type more closely. *Euceratothrips* Hood, another aeolothripid, likewise has elaborate sensoria, but, while similar in some respects

to the sensoria of *Franklinothrips* males, the sensoria of *Euceratothrips* is formed in a different manner (see Hood, Rev. de Ent. 6: 425-429, 1936).

In North America, the closest relative of *Franklinothrips* is *Stomatothrips*. In addition to the similarities in the sensoria, both have narrow wings, slightly broader at the apex; their maxillary palpi are somewhat the same, although in *Stomatothrips* the third segment is usually completely subdivided several times whereas only indications of subdivision are usual in *Franklinothrips*; and even the habits of the two may be similar for I have collected species of each of these genera from ecological niches that are grossly the same.

*Corynothripoides* Bagnall, in most classifications, is placed with *Franklinothrips* in the tribe Franklinothripini. Whether *Corynothripoides* is closer to *Franklinothrips* than to *Stomatothrips* on all characteristics is not clear to me. I have never seen *Corynothripoides* nor do the descriptions of this genus include information on the condition of all of the characters that I have studied in *Stomatothrips* and *Franklinothrips*.

#### NOMENCLATORIAL REMARKS

Three species, now in other genera, have been assigned to *Franklinothrips* for a brief time. Should names be designated subsequently to true *Franklinothrips* which are identical to the names of these three species, the thorny problem of secondary homonyms might be raised. Most certainly, circumvention of such difficulties by the avoidance of these names would be an advantage.

The three species involved are listed below with references. These names would best not be used again in *Franklinothrips*.

*Franklinothrips insularis* (Franklin):

*Franklinothr. insularis* (Fr.). Girault, New pests from Australia, VIII. Private publication, Brisbane, Aug. 16, 1930. [Misstatement for *Frankliniella insularis* Franklin. Corrected by Girault Dec. 29, 1930, in "New pests from Australia, IX," Brisbane.]

*Franklinothrips longiceps* (Crawford):

*Franklinothrips longiceps* (Crawford), Bagnall, Trans. 2nd Ent. Congress (1912): 397, 1913. [New combination from *Aeolothrips*. Reassigned to *Aeolothrips*, Hood, 1915.]

*Franklinothrips nasturtii* (Jones):

*Franklinothrips nasturtii* (Jones), Bagnall, Trans. 2d Ent. Congress (1912): 397, 1913. [New combination from *Aeolothrips*. Reassigned to *Aeolothrips*, Hood, 1915.]

#### LITERATURE

BACK, E. A. Notes on Florida *Thysanoptera*, with description of a new genus. Ent. News **23**: 73-77. 1912.

BAGNALL, R. S. A synopsis of the thysanopterous family *Aeolothripidae*. Trans. 2d Ent. Congress, 1912: 394-397. 1913a.

———. Notes on *Aeolothripidae*, with description of a new species. Journ. Econ. Biol. **8**: 154-158. 1913b.

———. On a collection of *Thysanoptera* from the West Indies, with descriptions of new genera and species. Journ. Linn. Soc., Zool., **32**: 495-507. 1915.

———. On a collection of *Thysanoptera* from St. Vincent, with descriptions of four new species. Journ. Zool. Res. **2**: 21-27. 1917.

———. The family *Franklinothripidae*, nov., with description of a new type of *Thysanopteron*. Ann. Mag. Nat. Hist. **17**: 168-173. 1926.

———. Contributions towards a knowledge of the European *Thysanoptera*—II. Ann. Mag. Nat. Hist. **19**: 564-575. 1927.

———. On the aeolothripid complex and the classification of the sub-order *Terebrantia* (*Thysanoptera*). Ges. Luxemburger Naturf. **25**: 115-118. 1931.

CRAWFORD, D. L. Some *Thysanoptera* of Mexico and the South, I. Pomona Coll. Journ. Ent. **1**(4): 109-119. 1909.

EBELING, W. *Subtropical entomology*: 747 pp. San Francisco, 1950.

ZOOLOGY.—A new genus and species of *Limnadiidae* from Venezuela (*Crustacea: Conchostraca*). N. T. MATTOX, College of Agriculture and Mechanic Arts, Mayagüez, Puerto Rico.<sup>1</sup> (Communicated by F. A. Chace, Jr.)

While making collections for the Venezuelan Scientific Expedition conducted by the University of Puerto Rico, one of the collectors, Jenaro Maldonado Capriles, observed many temporary rain pools which contained conchostracan phyllopods. One collection of 10 males and 11 females was made in a rock pool near Samariapo, Venezuela, on June 11, 1950. According to Mr. Maldonado, these animals were very abundant and many pools were inhabited by them, but only one collection was made. Study of these animals indicated that they are members of the family

GIRAULT, A. A. *New Australian animals so far overlooked by outsiders*. Private publication: 2 pp. Brisbane, 1927.

HOOD, J. D. On a collection of *Thysanoptera* from Panama. Psyche **20**: 119-124. 1913.

———. On some American *Aeolothripidae* (*Thysanoptera*). Ent. News **26**: 162-166. 1915.

———. *Brasilian Thysanoptera*, I. Rev. de Ent. **20** (1-3): 3-88. 1949.

KELLY, R., AND MAYNE, R. J. B. *The Australian thrips, a monograph of the order Thysanoptera in Australia*: 81 pp. Sydney, 1934.

MOULTON, D. *Thysanoptera from Africa*. Ann. Mag. Nat. Hist. **5**: 194-207. 1930.

———. *The Thysanoptera of South America* (1). Rev. de Ent. **2**: 451-484. 1932.

———. *Thysanoptera from Africa*. Ann. Mag. Nat. Hist. **17**: 493-509. 1936.

MOZNETTE, G. F. Annotated list of the injurious and beneficial insects of the Avocado in Florida. Florida Buggist **3** (Dec. 1919): 45-48. 1920.

PRIESNER, H. *Genera Thysanopterorum*. Bull. Soc. Fouad Ent. **33**: 31-157. 1949.

REIJNE, A. A cocoon-spinning thrips. Tijdschr. Ent. **63**: 40-45. 1920.

RICHTER, W. I. *Beitrag zur Kenntnis der Aeolothripiden* (*Thysanoptera*). Deutsch. Ent. Zeitschr. H. 1: 29-37. 1928.

TRYBOM, F. *Mitothrips, eine neue Physapodengattung aus Britischen Ostafrika*. Ent. Tidskr. Aig. **33** (3-4): 145-159. 1912.

WATSON, J. R. *Synopsis and catalog of the Thysanoptera of North America*. Univ. Florida Agr. Exp. Stat. Tech. Bull. **168**: 1-100. 1923.

WILLIAMS, C. B. Notes on some Trinidad thrips of economic importance. Trinidad and Tobago Bull. **17**: 143-146. 1918.

ZANON, D. V. *Nouva speciei di* (*Franklinothrips*) (*Thysanoptera*) *rinvenuta a Bengasi*. Atti Pontificia Acad. Sci. Nuovi Lincei **77**: 1-9 (separate). 1924.

*Limnadiidae* but are intergeneric in character and referable to a distinct and previously undescribed genus.

#### *Metalimnadia*, n. gen.

*Generic designation*.—Conchostracan phyllopods with 7 to 13 lines of growth in the adult, and a prominent anteriorly located umbo on the shell. Head without fornice: the prehensile frontal organ rudimentary and not pyriform. First antennae with two segments. Occipital notch prominent. Sixteen pairs of swimming appendages; first two pairs of male with prehensile claws; female ninth and tenth pairs with very long epipodite of exopodite for bearing eggs. Inferior, distal angle of telson with a small spine. The

<sup>1</sup>Contribution from the Department of Biology, College of Agricultural and Mechanic Arts University of Puerto Rico, Mayagüez, P. R.

posterior 15 of the body segments bear one or more dorsal spines.

Genotype: *Metalimnadia serratura*, n. sp.

***Metalimnadia serratura*, n. sp.**

*Description*.—Male: The male shell is elongate oval with a prominent umbo at one-fifteenth of the distance from the anterior margin (Fig. 1a). The number of lines of growth varies from 11 to 13, with much crowding at the anterior end of the shell. The dorsal margin is straight except at the posterior slope of the shell; the ventral margin is regularly rounded. The size of the adult shell averages 5.88 by 3.66 mm, varying from 5.5 mm long by 3.7 mm wide to 6.0 by 3.8 mm; the greatest height is just posterior to the middle. The height-length ratio averages 1:1.54.

The head presents definite generic and specific characters (Fig. 1b). The dorsal "frontal organ" is very rudimentary, being raised only slightly as a rounded knob with a central concavity. The front of the head is deeply concave with the rostrum extending in a very pronounced hooklike beak. The first antennae are distinctive in that they have two segments, the distal one clavate. The second antennae are biramous, each branch with nine segments and each segment with a varying number of long, dorsal spines. The occipital notch is prominent. The ocellus is very pronounced.

The body bears 16 pairs of swimming appendages. The first and second pairs are modified into typical claspers. The claspers of the first pair are very broad; the fourth endite has a short knoblike lateral extension, and the two segments of the sixth endite are approximately of equal length (Fig. 1c). The claspers of the second pair are more slender; the terminal segment of the sixth endite is approximately 1.5 times longer than the first segment (Fig. 1d). The exopodites on both pairs of claspers are very short. The branchiae, as on the other appendages, are broad.

The dorsal surface of the first body segment is bare; the other segments bear 1 to 5 dorsal spines, those on the posterior segments being longer and more slender (Fig. 1e). An example of a typical spine formula is: 0-1-2-2-2-3-3-4-4-4-5-4-4-3-1-1. The telson is very truncate. The dorsal ridges of the telson are regularly serrated with an average number of 12 evenly spaced and pronounced sawtoothlike spines; a biramous filamentous spine arises between the third and

fourth dorsal spines. The pair of ventral, posterior, movable spines have bristlelike spines on the proximal portion with microspines on the sharply attenuated terminal portion. On the inferior distal margin of the telson is a small spine.

Female: The female shell is similar to, but smaller than, that of the male. It is more ventricose and more rounded on the dorsal margin than in the male (Fig. 1f). The umbo is less pronounced and there is a median, shallow indentation on the ventral margin. The usual number of growth lines is 10, with a variation from 7 to 10. In size the female shell averages 4.94 mm long by 3.39 mm in height. The variation in the 11 females is from 4.5 mm by 3.0 mm to 5.4 by 3.5 mm. The height-length ratio is 1:1.45.

The head of the female is smaller and less elongate, but similar to that of the male. The front is deeply concave, the rostrum beaklike. The ocellus is very pronounced, the frontal organ very rudimentary, and the first antennae 2-segmented (Fig. 1h).

The 16 pairs of trunk appendages are swimming legs typical of the group. The first pair have well marked endites; the sixth endite extends about to the end of the fifth endite (Fig. 1i). The branchiae, as in the male, are very broad. The ninth and tenth pairs of legs possess a greatly extended basal exopodite flabellum for the attachment and carrying of eggs; this flabellum is twice as long as the length of the rest of the appendage (Fig. 1j). The eggs are spherical, with rough surface, and average 0.3 mm in diameter (Fig. 1g). The dorsal ridges of the trunk segments are variously spined as in the male, and the telson is similar to that of the male.

*Type locality*.—Samariapo, Territorio Amazonas, Venezuela.

*Types*.—Holotype, male, U.S.N.M. no. 92292, and paratypes, both sexes, U.S.N.M. no. 92293, in the U. S. National Museum and in the writer's collection.

*Remarks*.—*Metalimnadia serratura* differs from other members of the family Limnadiidae in so many characters as to nearly warrant a subfamily or separate family designation. However, the general form of the body, number of trunk appendages, form of the telson, and the first two pairs of male claspers, find closer resemblance in the Limnadiidae than in any of the other conchostracan families. Many of the other morphological characters, however, are very different from those of other Limnadiidae.

The shell of *M. serratura* is more estheriidlike than it is like the shells of the other Limnadiidae. No member of the genus *Eulimnadia* has as many

growth lines or an umbo as well developed. In *Limnadia*, only the male of *L. stanleyana* King from Australia has a shell with a well-pronounced

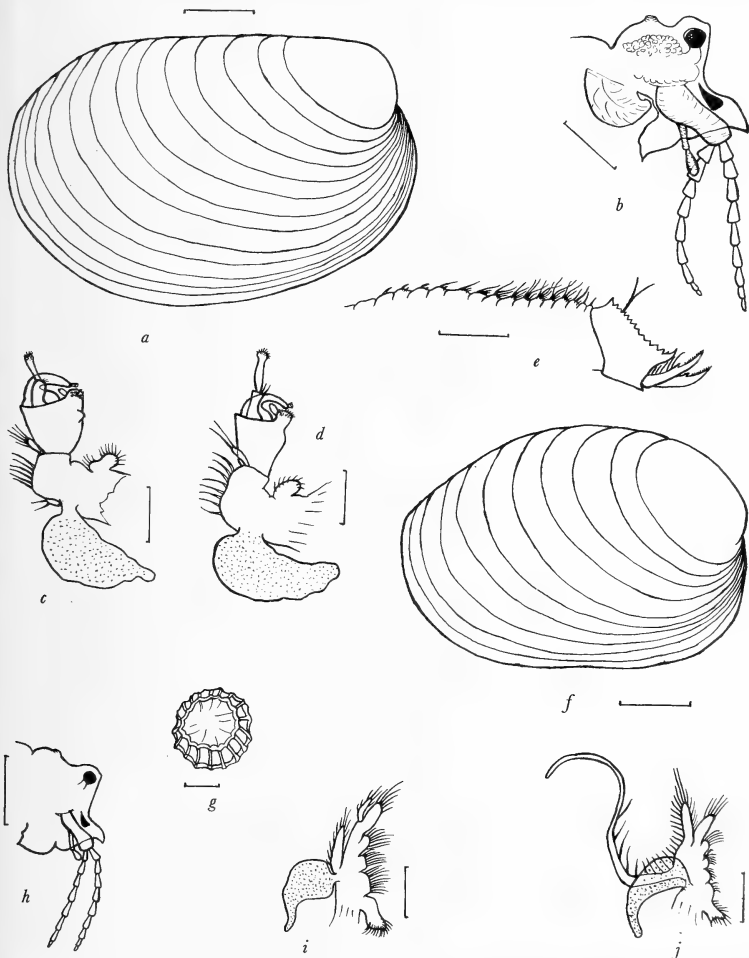

FIG. 1.—*Metalimnadia serratura*, n. gen., n. sp. a-e, male: a, Lateral view of shell; b, lateral view of head; c, first pair of claspers; d, second pair of claspers; e, lateral view of trunk and telson. f-j, female: f, Lateral view of shell; g, an egg; h, lateral view of head; i, a first trunk appendage; j, tenth trunk appendage. Scales a, b, e, f, h equal 1 mm; c, d, i, j equal 0.5 mm; g equals 0.1 mm.

umbo and as many lines of growth. The female of this latter species has a very different shell. All species of *Limnadiopsis*, the other genus of the family, are unique in having a very noticeably serrated dorsal shell margin.

The head characters of *M. serratura* are very different from those of the other members of the family, although the general form of the head is similar to that of the other genera. As indicated by Daday (1915, 1925) the Limnadiidae are characterized by a prominent, pyriform frontal appendage. This frontal organ in *M. serratura* is very rudimentary, not pyriform, and it is raised only slightly above the dorsal surface of the head. What may be the evolutionary status of this very characteristic limnadiid feature among the different genera cannot be indicated at this time. The first antennae of all the other members of the family are elongate, unsegmented appendages with a series of dorsally located sensory papillae. The 2-segmented first antennae of *M. serratura* are more like those of the Lynceidae than any other of the Conchostraca. These appendages are strongly diagnostic for the present genus and species.

**HELMINTHOLOGY.**—*Some cestodes from Oregon shrews, with descriptions of four new species of Hymenolepis Weinland, 1858.* BETTY LOCKER, Reed College, Portland, Oreg., and ROBERT RAUSCH, Arctic Health Research Center, Anchorage, Alaska.

A large number of shrews of the genus *Sorex* has been examined in connection with the investigation of the helminth parasites of Oregon mammals. It is the purpose of this paper to give a preliminary list of the cestodes obtained from these shrews, together with the description of new species. More complete information on these and other helminths will be published by one of us (B. L.) at a later date.

The helminths reported here have been collected from *Sorex v. vagrans* Baird, the most common shrew of western Oregon during the time these collections were made. Host determinations were made by comparing our material with specimens in the mammal collections of the U. S. National Museum.

In addition to the species herein described, we have also recorded three previously described cestodes from Oregon shrews. These observations appear to be the first to be

As pointed out by Linder (1945) many species of *Limnadia* have only 16 pairs of trunk appendages, as does *M. serratura*. Other members of the family may have up to 32 pairs. The first two pairs of male claspers are characteristic, but, as on the other trunk appendages, the branchiae are much larger and proportionately wider than in the other genera. The egg-bearing exopodite of the ninth and tenth female appendages is proportionately much longer than typically found in the Limnadiidae. The telson, with the inferior distal spine, is more like that of *Eulimnadia*, than that of the other genera.

It seems as if this species, *Metalimnadia serratura*, represents a newly found intergeneric line of evolution in the family Limnadiidae.

#### LITERATURE CITED

- DADAY DE DEES, E. *Monographie systématique des phyllopes conchostracés.* Ann. Sci. Nat., Zool., ser. 9, 20: 39-192. 1915. *Ibid.*, ser. 10, 8: 143-184. 1925.
- LINDER, FOLKE. *Affinities within the Branchiopoda, with notes on some dubious fossils.* Ark. für Zool. 37(4): 1-28. 1945.

made on cestodes in shrews from the Pacific coast region. Each species is considered separately below.

#### *Protogynella blarinae* Jones, 1943

This minute cestode of uncertain status was found to occur commonly in Oregon shrews. The Oregon specimens were not considered in detail, since another worker has already undertaken the restudy of the species; however, as far as was determined these cestodes were morphologically identical with those found in shrews (*Sorex c. cinereus* Kerr; *Blarina brevicauda* Say) in the eastern States. It was noted, however, that the Oregon specimens had a much larger number of hooks than was reported from Wisconsin shrews (Rausch and Kuns, 1950). Because of the minute size and proximity of these rostellar hooks, an accurate count was impossible; however, the number is near one hundred. Whether or not this represents only variation can be determined on the basis of the study of specimens from different geographical locations.

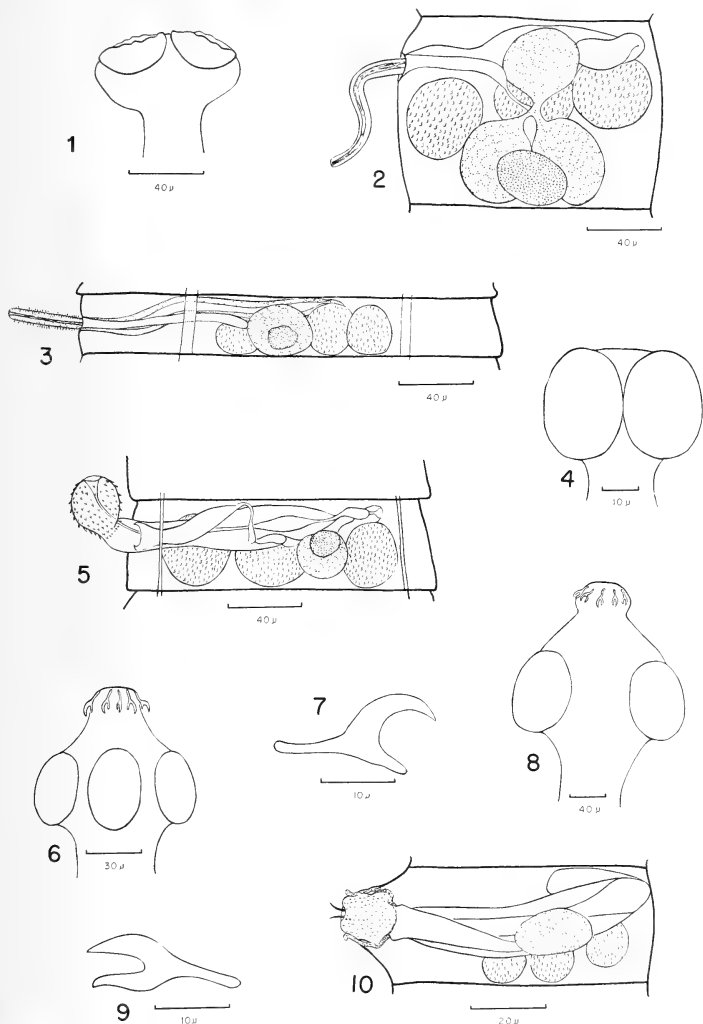

FIGS. 1-10.—1, Scolex of *H. macyi*; 2, mature segment of *H. macyi*; 3, mature segment of *H. kenki*; 4, scolex of *H. kenki*; 5, mature segment of *H. sphenomorphus*; 6, scolex of *H. sphenomorphus*; 7, rostellar hook of *H. sphenomorphus*; 8, scolex of *H. intricatus*; 9, rostellar hook of *H. intricatus*; 10, mature segment of *H. intricatus*.

**Hymenolepis falcata** Rausch and Kuns, 1950

Although not a common species when compared with some of the other cestodes occurring in Oregon shrews, *H. falcata* was collected frequently. This is perhaps the most common species occurring in *Sorex cinereus* in southern Wisconsin, but it has not yet been recorded from other localities. The specimens examined from *S. vagrans* were morphologically identical with material from the type locality.

**Hymenolepis schilleri** Rausch and Kuns, 1950

The study of abundant material from Oregon shrews has allowed some further observations on the morphology of *H. schilleri*, which so far is known only from the two specimens upon which the original description was based. It has been found that the number of rostellar hooks is variable, and a maximum number of 32 has been recorded. In regard to other morphological characters, the original description is adequate.

**Hymenolepis macyi**, n. sp.

Figs. 1, 2, 11

*Diagnosis*.—Hymenolepididae. Strobila length up to 2 mm; greatest width, attained in gravid segments, 500 $\mu$ . Strobila characterized by relatively large size of gravid segments, up to 500 by 250 $\mu$ . Transition from immature to mature segments, and from mature to gravid segments, very abrupt; this results in tripartite appearance of strobila. There are usually 4 to 6 segments in each (immature, mature, and gravid) section of strobila, with maximum possible segment number about 18. Immature and early mature segments wider than long; late mature segments nearly square; gravid segments oval. Scolex 180 to 230 $\mu$  in diameter, strongly set off from neck; rostellum absent. Suckers oval, about 100 $\mu$  long. Genital pores unilateral and dextral, situated near anterior end of margin of segment. Cirrus sac, as much as 400 $\mu$  long by 70 $\mu$  wide, extends nearly across mature segment to anterior aporal corner. Cirrus unarmed. External seminal vesicle strongly developed. Testes in mature segments measure about 35 $\mu$  in diameter, and are situated in diagonal row with aporal testis most anterior. Vagina, about 8 $\mu$  in diameter in mature segments, situated ventral to cirrus sac; it narrows abruptly just poral to ovary. Seminal receptacle not noted. Ovary trilobed, situated near center of segment; two lobes posterior and one anterior. Ovarian lobes subspherical, each about 30 $\mu$  in diameter in mature segments. Vitelline gland on midline of

segment at posterior edge of ovary, and ventral to it. Development of uterus abrupt; gravid segment capsulelike, with thick parenchyma around egg-filled uterus. Genital ducts persist in terminal segments. Eggs spherical, from 30 to 32 $\mu$  in diameter.

*Host*.—*Sorex v. vagrans* Baird.

*Type locality*.—Portland, Oreg.

*Habitat*.—Small intestine.

*Type*.—A slide containing an entire specimen has been deposited in the Helminthological Collection of the U. S. National Museum, no. 47531.

*Hymenolepis macyi* appears to be well characterized by the unusual gross appearance of the strobila, and can be differentiated on this basis from the other unarmed soricid species of *Hymenolepis* (*H. alpestris* Baer, 1931; *H. anthocephalus* Van Gundy, 1935; *H. diaphana* Kholodkowski, 1906; *H. globosa* Baer, 1931; *H. minuta* Baer, 1926; *H. soricis* Baer, 1925). It can be further differentiated on the basis of cirrus sac position and size, arrangement of testes and ovary, and egg size.

This cestode is named in honor of Dr. Ralph W. Macy, chairman, department of biology, Reed College, Portland, Oreg. This opportunity is taken to express appreciation of his providing facilities and working space in connection with part of this work.

**Hymenolepis kenki**, n. sp.

Figs. 3, 4, 12

*Diagnosis*.—Hymenolepididae. Strobila 1 to 2 mm long; greatest width, attained in gravid segments, slightly over 200 $\mu$ . Strobila consists of about 50 segments, all wider than long with a slight relative increase in length in gravid segments. Scolex 280 to 340 $\mu$  in diameter; rostellum absent. Suckers strongly developed, elliptical, about 180 $\mu$  long. Genital pores unilateral and dextral, situated near middle of segmental margin. Cirrus sac, usually about 100 $\mu$  long by about 20 $\mu$  wide in mature segments, extends aporally to just beyond midline of segment. Cirrus thickly set with fine spines. External seminal vesicle present. Testes spherical, about 30 $\mu$  in diameter in mature segments; situated in straight line with two aporal and one poral. Vagina ventral to cirrus sac; diameter uniform and course direct as far aporal as poral margin of ovary. Seminal receptacle not evident. Ovary subspherical, about 30 $\mu$  in length, situated near midline of segment. Vitelline gland ventral to ovary. Uterus appears early in strobila as spheri-



cal body which gradually enlarges to fill entire gravid segment. Eggs apparently spherical, 19 to 22 $\mu$  in diameter; fully-developed eggs in terminal segments highly distorted by fixation in all available material.

*Host*.—*Sorex v. vagrans* Baird.

*Type locality*.—Portland, Oreg.

*Habitat*.—Small intestine.

*Type*.—A slide containing paratype material has been deposited in the Helminthological Collection of the U. S. National Museum, no. 47532.

On the basis of testes arrangement (straight line) as well as by other morphological characters, *H. kenki* can be differentiated from the soricid species of *Hymenolepis* which have the testes arranged in a triangle (*H. anthocephalus* Van Gundy, 1935; *H. alpestris* Baer, 1931; *H.*

*diaphana* Kholodkowsky, 1906; *H. globosa* Baer, 1931). It may be differentiated from *H. minuta* Baer, 1926, and from *H. soricis* Baer, 1925, which also have the testes arranged in a straight line, by size and relative length of cirrus sac, by egg size (?), and other morphological characters. However, *H. soricis* is poorly known, and *H. minuta* was described on the basis of an immature specimen.

This cestode is named in honor of Dr. Roman Kenk, of Washington, D. C.

***Hymenolepis sphenomorphus*, n. sp.**

Figs. 5-7, 13

*Diagnosis*.—Hymenolepididae. Strobila length up to 800 $\mu$ ; greatest width, attained in terminal segments, about 200 $\mu$ . Wedge-shaped strobila of

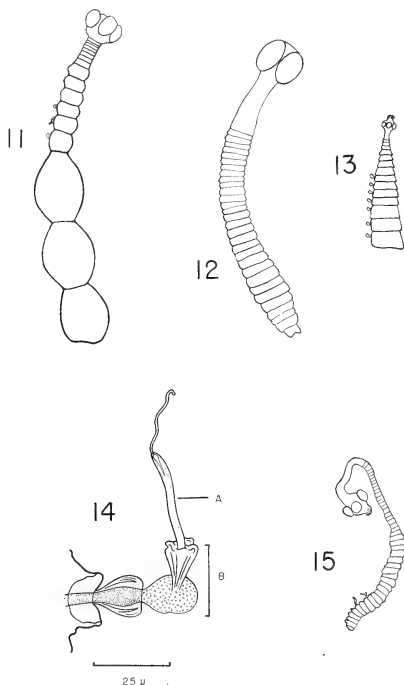

FIGS. 11-15.—11, Entire strobila of *H. macyi*; 12, entire strobila of *H. kenki*; 13, entire strobila of *H. sphenomorphus*; 14, semidiagrammatic drawing of cirrus (A) and vagina (B) of *H. intricatus*, showing attachment; 15, entire strobila of *H. intricatus*. (Figs. 11, 12, 13, and 15 all drawn to same scale with the aid of a projector.)

characteristic gross appearance. Segments, about 15 in number, wider than long; they become relatively longer when gravid. Strobila margins serrate. Scolex  $90\mu$  in diameter, distinctly set off from neck. Rostellum well developed, armed with 10 hooks 16 to  $20\mu$  long. Suckers elliptical, about  $45\mu$  long. Genital pores unilateral and dextral, situated near middle of margin of segment. Cirrus sac attains length of  $110\mu$  and width of  $25\mu$  in mature segments, and extends aporally beyond midline of segment. Cirrus strongly developed, and furnished with spined terminal knob 30 to  $32\mu$  in diameter. External seminal vesicle present. Subspherical to ovoid testes about  $35\mu$  in diameter in mature segments; testes arranged in straight line, with two poral to ovary, and one aporal. Thin-walled vagina ventral to cirrus sac; about  $20\mu$  in diameter near genital pore. Vagina narrows abruptly to slender duct at distance of about  $60\mu$  from poral margin of segment; small seminal receptacle formed just poral to ovary. Ovary subspherical, about  $35\mu$  in diameter, situated aporal of midline ventral to testes. Vitelline gland ovoid, situated ventral to ovary. Uterus gradually enlarges in central part of segment; gravid segments completely filled with eggs. Eggs measure 16 to  $19\mu$ .

*Host*.—*Sorex v. vagrans* Baird.

*Type locality*.—Multnomah Falls, Oreg.

*Habitat*.—Small intestine.

*Type*.—A slide containing an entire specimen has been deposited in the Helminthological Collection of the U. S. National Museum, no. 47533.

*Hymenolepis sphenomorphus* is characterized grossly by the very small, wedge-shaped strobila in combination with the extreme relative size of the cirrus. It is differentiated from the other soricid species which have 10 hooks (*H. blarinae* Rausch and Kuns, 1950; *H. jacobsoni* von Linstow, 1907; *H. parva* Rausch and Kuns, 1950; *H. scutigera* (Dujardin, 1845); *H. singularis* Kholodkowsky, 1913) by differences in hook size and shape, size and location of cirrus sac, and character of the cirrus.

Six specimens of this cestode were obtained from a shrew captured under a log along the Columbia River near Multnomah Falls. This parasite was collected but once, and was the least common form considered here.

#### *Hymenolepis intricatus*, n. sp.

Figs. 8-10, 14, 15

*Diagnosis*.—Hymenolepididae. Strobila length 1.2 to 2 mm; greatest width, attained near middle

of strobila, about  $100\mu$ . Strobila margins not serrate; all segments wider than long. Total number of segments 60 to 75. Scolex strongly developed, 160 to  $180\mu$  in diameter; distinctly set off from unsegmented neck. Rostellum well developed, armed with 10 hooks 17 to  $21\mu$  long. Suckers 90 to  $100\mu$  long. Genital pores unilateral and dextral, situated near middle of margin of segment on projection of segmental margin. Cirrus sac large, attaining length of 75 by  $16\mu$  in mature segments, and extending aporally nearly to margin of segment. External seminal vesicle well developed. Cirrus spinose and slender. Testes situated in diagonal line, all aporal of midline. Spherical testes measure about  $10\mu$  in mature segments. Vagina thin-walled, of about same diameter as cirrus sac. Terminal part of vagina highly specialized, having a bulblike, heavily spined section which adjoins a terminal, funnel-like structure whose wall is supported by several rigid spicules. This organ is capable of being extruded, and appears to function in connection with clasping during copulation. No seminal receptacle noted. Ovary subspherical, up to  $20\mu$  long in mature segments. Vitelline gland not observed. Uterus develops gradually as single body; gravid segments completely filled with eggs. Eggs ovoid, apparently about  $25\mu$  in length; accurate measurement prevented by distortion resulting from fixation.

*Host*.—*Sorex v. vagrans* Baird.

*Type locality*.—Portland, Oreg.

*Habitat*.—Small intestine.

*Type*.—A slide bearing paratype material has been deposited in the Helminthological Collection of the U. S. National Museum, no. 47534.

This species may be differentiated from related forms having 10 hooks (see above) on the basis of hook size and shape, size and position of cirrus sac and other genital organs, and particularly by the apparently unique development of the terminal part of the vagina.

The finer details of the vagina of this cestode could not be completely worked out, because of the extremely small size; however, it is evident that the vagina demonstrates a much higher degree of specialization than is ordinarily seen in the species of *Hymenolepis*. The vagina is capable of being extruded to a distance of more than  $20\mu$  beyond the margins of the genital atrium, which itself possesses a thick, chitinlike wall. The heavy spicules seen in the terminal part of the vagina seem to act as a support for this structure, but their function is not clearly understood. From ob-

servations on a large series of these cestodes, it is concluded that once contact is established between the cirrus and vagina, separation may not often occur. Both intersegmental and interstrobilar copulation were recognized, and in the case of the latter, apparently as a result of manipulation when the worms were removed from the host, it was commonly seen that either the vagina or cirrus was torn completely free from the segment. This resulted in the two organs remaining tightly attached (Fig. 15).

This cestode was frequently observed in Oregon shrews and was one of the common species, along with *H. macyi* and *H. kenki*.

#### DISCUSSION

The description of the four species of cestodes here brings the total number of species recorded from North American shrews to 11. All the North American species are well characterized and can be readily differentiated. It would appear that the species of *Hymenolepis* parasitic in North American shrews have evolved quite separately from those found in the Eurasian mammals, since no Eurasian species has so far been recorded from North America. When more nearly complete information has been obtained there may be derived from it some under-

standing of the zoogeographically important implications which are involved.

#### SUMMARY

Seven species of cestodes have been recorded from Oregon shrews (*Sorex v. vagrans* Baird). Of these, *Protogynella blarinae* Jones, 1943, *Hymenolepis falculata* Rausch and Kuns, 1950, and *H. schilleri* Rausch and Kuns, 1950, are recorded here for the first time from the western part of North America. Four species of *Hymenolepis*, *H. macyi*, *H. kenki*, *H. sphenomorphus*, and *H. intricatus*, are described as new.

#### REFERENCES

- BAER, J. G. *Cestodes de mammifères. 2. Une nouvelle espèce d'Hymenolepis parasite d'un insectivore*. Bull. Soc. Neuchâtel. Sci. Nat. **50**: 80-81. 1925.
- . *Contribution à la faune helminthologique de Suisse*. Rev. Suisse Zool. **39**: 1-57. 1932.
- JONES, A. W. *Protogynella blarinae n.g., n.sp., a new cestode from the shrew, Blarina brevicauda Say*. Trans. Amer. Micr. Soc. **62**: 169-173. 1943.
- JOYEUX, CH., and BAER, J. G. *Cestodes*. Faune de France **30**, 610 pp. Paris, 1936.
- RAUSCH, R., and KUNS, M. L. *Studies on some North American shrew cestodes*. Journ. Parasitol. **36**: 433-438. 1950.
- VAN GUNDY, C. O. *Hymenolepis anthocephalus, a new tapeworm from the mole shrew, Blarina brevicauda Say*. Trans. Amer. Micr. Soc. **54**: 240-244. 1935.

ORNITHOLOGY.—*The long-tailed sugarbird of eastern Rhodesia*.<sup>1</sup> HERBERT FRIEDMANN, U. S. National Museum.

In his second paper on the birds of Gazaland, Swynnerton (Ibis, 1908: 31-32) recorded the Natal long-tailed sugarbird from the scrub-grown kloofs of the Melsetter District, extreme eastern Southern Rhodesia, and remarked that the bird was previously unknown north of the Limpopo, being recorded only from Natal, Swaziland, and the Transvaal. However, some eight years earlier Stark (*Fauna of South Africa, Birds*, **1**, 273. 1900) included Gazaland in the range of the species, although on what basis he did so is a mystery as there appear to be no published records prior to Swynnerton's. Indeed,

several authors, such as Shelley and Reichenow, who refer to Stark's book, give the distribution of the species merely as Natal, Zululand, and the Transvaal, and either overlooked or doubted the stated occurrence in Gazaland. Since Swynnerton's day no notable extension of range has been reported for the bird in spite of very considerable work in eastern parts of the Union of South Africa, Southern Rhodesia, and Portuguese East Africa. It appears, then, that the bird has a very discontinuous range, which, in light of present knowledge, may be stated as from Pondoland in the eastern Cape Province, through Natal, Zululand, Swaziland, and the Drakensberg Mountains north to the Zoutpansberg area of the eastern Transvaal, and then again, after a long geographic gap of at least 200 miles of unsuitable

<sup>1</sup> Published by permission of the Secretary of the Smithsonian Institution. For the loan of specimens for study in the present connection I am indebted to the authorities of the American Museum of Natural History, the Chicago Natural History Museum, and the National Museum of Southern Rhodesia.

country, in the Melsetter District of Southern Rhodesia, near the Portuguese border.

Populations that are strikingly isolated geographically frequently reveal morphological characters worthy of nomenclatural recognition, and I was interested to examine and to compare Melsetter *Promerops* with others from eastern South Africa. When in Southern Rhodesia in 1950 I was able to acquire from Capt. Cecil D. Priest a number of birds he had obtained some years earlier in Gazaland, and among them was a fine adult male *Promerops*. Through the kindness of Reay H. N. Smithers, two additional examples (adult females) from Rocklands, in the Melsetter area, in the collections of the National Museum of Southern Rhodesia, have been made available to me for study. These three birds have been compared carefully with six examples of typical *gurneyi* from Natal and the northeastern Transvaal, and prove to represent a readily distinguishable race, which may be known as

*Promerops cafer ardens*, n. subsp.

*Type*.—U.S.N.M. no. 433386, ad. ♂, collected at Melsetter, Southern Rhodesia, May 13, 1939, by Cecil Damer Priest; orig. no. 290.

*Subspecific character*.—Similar to *Promerops cafer gurneyi*, but with the pectoral band conspicuously brighter and darker—between Hazel<sup>2</sup> and Mikado Brown, as opposed to Sayal Brown in *gurneyi*, with the rump and upper tail coverts less yellowish, more greenish—dusky Warbler Green as compared with Pyrite Yellow in *gurneyi*, with the upperparts generally darker, the centers of the feathers blacker—Chaetura Black (Fuscous in *gurneyi*), the cheeks darker—dusky Olive Brown (Drab in *gurneyi*), the tail feathers darker, the median ones more blackish below than in *gurneyi*, and the streaks on the sides and flanks are more blackish, less brownish than in the birds of the highlands of Natal and the northeastern Transvaal. An adult male from Woodbush, northeastern Transvaal, agrees with topotypical *gurneyi* from Natal in all the color characters. There seem to be no significant differences in dimensions between the two races, although not enough specimens have been available for measurement to be certain. The measurements of the type of *P. c. ardens* are wing 92, tail 170, culmen from the base 31.8, exposed culmen 26.2;

tarsus 19.6 mm. The two females measure—wing 80, 88.2; tail 115+, 148+, culmen from the base 29, 29.7; exposed culmen 26, 27; tarsus 21, 22 mm.

Darrel C. H. Plowes, who knows the habits of both the Natal-Transvaal race and the Melsetter form, has kindly supplied me with some pertinent facts about them. He tells me that in parts of Melsetter *Brachystegia* is the dominant tree with the *Proteas* being secondary, whereas in the Transvaal *Brachystegia* is absent. The ecological differences between the Transvaal section of the Drakensberg, and the Chimanimani Mountains in the Melsetter area have resulted in a number of endemic forms being found in the latter area, to which number the new *Promerops* is the latest addition.

Plowes noted *Promerops* was not uncommon around Melsetter village, though only rarely seen on the Martin Forest Reserve, an area of some 25,000 acres to the north and northeast. The birds were very common in the *Protea-Brachystegia-Phillipia* scrub on "Gwendengwe," some 15 miles to the east, and do not seem to stray far from this botanical complex.

There has been some discussion in the literature as to whether all the forms of *Promerops* are conspecific or if *cafer* is one species and *gurneyi* (with *ardens*) another species. It is true that *cafer* differs in having a very much longer tail and in lacking the rufous to a large extent on the crown, and, on the breast as well, but in habits the two groups are said to be alike, and geographically they do replace each other, i.e., they are representative forms. Final solution of this problem must wait until someone with adequate material from all parts of the range of the whole group and with sufficient data on their habits makes a comprehensive study. It is relatively seldom that one finds two closely related birds that show such marked morphological differentiation apparently unaccompanied by any differences in habit. The opposite condition—slight morphological differences coupled with considerable divergences in habit is much more frequent, as for example, in congeneric species of African pipits (*Anthus*) and grass warblers (*Cisticola*) or American tyrant flycatchers (*Empidonax*).

<sup>2</sup> Capitalized color terms *ex* Ridgway, *Color standards and color nomenclature*.

## Officers of the Washington Academy of Sciences

*President*.....NATHAN R. SMITH, Plant Industry Station  
*President-elect*.....WALTER RAMBERG, National Bureau of Standards  
*Secretary*.....F. M. DEFANDORF, National Bureau of Standards  
*Treasurer*.....HOWARD S. RAPPLEYE, U. S. Coast and Geodetic Survey  
*Archivist*.....JOHN A. STEVENSON, Plant Industry Station  
*Custodian and Subscription Manager of Publications*  
 HAROLD A. REHDER, U. S. National Museum

### *Vice-presidents Representing the Affiliated Societies:*

Philosophical Society of Washington.....EDWARD U. CONDON  
 Anthropological Society of Washington.....WALDO R. WEDEL  
 Biological Society of Washington.....  
 Chemical Society of Washington.....JOSEPH J. FAHEY  
 Entomological Society of Washington.....FREDERICK W. POOS  
 National Geographic Society.....ALEXANDER WETMORE  
 Geological Society of Washington.....LEASON H. ADAMS  
 Medical Society of the District of Columbia.....  
 Columbia Historical Society.....GILBERT GROSVENOR  
 Botanical Society of Washington.....E. H. WALKER  
 Washington Section, Society of American Foresters.....WILLIAM A. DAYTON  
 Washington Society of Engineers.....CLIFFORD A. BETTS  
 Washington Section, American Institute of Electrical Engineers

FRANCIS M. DEFANDORF  
 Washington Section, American Society of Mechanical Engineers.....RICHARD S. DILL  
 Helminthological Society of Washington.....L. A. SPINDLER  
 Washington Branch, Society of American Bacteriologists.....ANGUS M. GRIFFIN  
 Washington Post, Society of American Military Engineers.....HENRY W. HEMPLE  
 Washington Section, Institute of Radio Engineers.....HERBERT G. DORSEY  
 District of Columbia Section, American Society of Civil Engineers

MARTIN A. MASON

### *Elected Members of the Board of Managers:*

To January 1952.....W. F. FOSHAG, C. L. GAZIN  
 To January 1953.....C. F. W. MUESEBECK\*, A. T. MCPHERSON  
 To January 1954.....SARA E. BRANHAM, MILTON HARRIS\*

*Board of Managers*.....All the above officers plus the Senior Editor  
*Board of Editors and Associate Editors*.....[See front cover]

*Executive Committee*.....N. R. SMITH (chairman), WALTER RAMBERG, H. S. RAPPLEYE,  
 J. A. STEVENSON, F. M. DEFANDORF

*Committee on Membership*.....E. H. WALKER (chairman), M. S. ANDERSON, R. E.  
 BLACKWELDER, R. C. DUNCAN, G. T. FAUST, I. B. HANSEN, D. B. JONES, DOROTHY  
 NICKERSON, F. A. SMITH, HEINZ SPECHT, ALFRED WEISSLER

*Committee on Meetings*.....MARGARET PITTMAN (chairman), NORMAN BEKEDAH,  
 W. R. CHAPLINE, D. J. DAVIS, F. B. SCHEETZ, H. W. WELLS

### *Committee on Monographs:*

To January 1952.....J. R. SWALLEN (chairman), PAUL H. OEHSER  
 To January 1953.....R. W. IMLAY, P. W. OMAN  
 To January 1954.....S. F. BLAKE, F. C. KRACEK

*Committee on Awards for Scientific Achievement* (GEORGE P. WALTON, general chairman):

For the Biological Sciences.....G. H. COONS (chairman), J. E. FABER, Jr.,  
 MYRNA F. JONES, F. W. POOS, J. R. SWALLEN

For the Engineering Sciences.....R. S. DILL (chairman), ARSHAM AMIRIKIAN,  
 J. W. MCBURNEY, FRANK NEUMANN, A. H. SCOTT

For the Physical Sciences.....G. P. WALTON (chairman), F. S. BRACKETT,  
 G. E. HOLM, C. J. HUMPHREYS, J. H. McMILLEN

For Teaching of Science.....B. D. VAN EVERA (chairman), R. P. BARNES,  
 F. E. FOX, T. KOPFANYI, M. H. MARTIN, A. T. MCPHERSON

*Committee on Grants-in-aid for Research*.....L. E. YOCUM (chairman),  
 M. X. SULLIVAN, H. L. WHITTEMORE

### *Committee on Policy and Planning:*

To January 1952.....J. I. HOFFMAN (chairman), M. A. MASON  
 To January 1953.....W. A. DAYTON, N. R. SMITH  
 To January 1954.....H. B. COLLINS, JR., W. W. RUBEY

### *Committee on Encouragement of Science Talent:*

To January 1952.....M. A. MASON (chairman), A. T. MCPHERSON  
 To January 1953.....A. H. CLARK, F. L. MOHLER  
 To January 1954.....J. M. CALDWELL, W. L. SCHMITT

*Representative on Council of A. A. A. S.*.....F. M. SETZLER  
*Committee of Auditors*.....J. H. MARTIN (chairman), N. F. BRAATEN, W. J. YOUNDEN  
*Committee of Tellers*.....W. G. BROMBACHER (chairman), A. R. MERZ, LOUISE M. RUSSELL

\* Appointed by Board to fill vacancy.

## CONTENTS

	Page
ETHNOLOGY.—Utilization of animals and plants by the Malecite Indians of New Brunswick. FRANK G. SPECK and RALPH W. DEXTER. . . .	1
PALEONTOLOGY.—Stratigraphic range of the ostracode genus <i>Phanasymetria</i> Roth. I. G. SOHN and JEAN M. BERDAN. . . . .	7
PALEONTOLOGY.—The arms of <i>Polusocrinus</i> . HARRELL L. STRIMPLE. . .	12
ENTOMOLOGY.—Phylogenetic studies of <i>Franklinothrips</i> (Thysanoptera: Aeolothripidae). LEWIS J. STANNARD, JR. . . . .	14
ZOOLOGY.—A new genus and species of Limnadiidae from Venezuela (Crustacea: Conchostraca). N. T. MATTOX. . . . .	23
HELMINTHOLOGY.—Some cestodes from Oregon shrews, with descriptions of four new species of <i>Hymenolepis</i> Weinland, 1858. BETTY LOCKER and ROBERT RAUSCH. . . . .	26
ORNITHOLOGY.—The long-tailed sugarbird of eastern Rhodesia. HERBERT FRIEDMANN. . . . .	13

JOURNAL  
OF THE  
WASHINGTON ACADEMY  
OF SCIENCES

BOARD OF EDITORS

WILLIAM F. FOSHAG  
U.S. NATIONAL MUSEUM

J. P. E. MORRISON  
U.S. NATIONAL MUSEUM

JOHN C. EWERS  
U.S. NATIONAL MUSEUM

ASSOCIATE EDITORS

F. A. CHACE, JR.  
BIOLOGY

J. I. HOFFMAN  
CHEMISTRY

T. P. THAYER  
GEOLOGY

MIRIAM L. BOMHARD  
BOTANY

R. K. COOK  
PHYSICS AND MATHEMATICS

PHILIP DRUCKER  
ANTHROPOLOGY

C. W. SABROSKY  
ENTOMOLOGY

PUBLISHED MONTHLY  
BY THE  
WASHINGTON ACADEMY OF SCIENCES  
MOUNT ROYAL & GUILFORD AVES.  
BALTIMORE, MARYLAND



Entered as second class matter under the Act of August 24, 1912, at Baltimore, Md.  
Acceptance for mailing at a special rate of postage provided for in the Act of February 28, 1925.  
Authorized February 17, 1949

## Journal of the Washington Academy of Sciences

This JOURNAL, the official organ of the Washington Academy of Sciences, publishes: (1) Short original papers, written or communicated by members of the Academy; (2) proceedings and programs of meetings of the Academy and affiliated societies; (3) notes of events connected with the scientific life of Washington. The JOURNAL is issued monthly. Volumes correspond to calendar years.

*Manuscripts* may be sent to any member of the Board of Editors. It is urgently requested that contributors consult the latest numbers of the JOURNAL and conform their manuscripts to the usage found there as regards arrangement of title, subheads, synouymies, footnotes, tables, bibliography, legends for illustrations, and other matter. Manuscripts should be typewritten, double-spaced, on good paper. Footnotes should be numbered serially in pencil and submitted on a separate sheet. The editors do not assume responsibility for the ideas expressed by the author, nor can they undertake to correct other than obvious minor errors.

*Illustrations* in excess of the equivalent (in cost) of one full-page halftone are to be paid for by the author.

*Proof.*—In order to facilitate prompt publication one proof will generally be sent to authors in or near Washington. It is urged that manuscript be submitted in final form; the editors will exercise due care in seeing that copy is followed.

*Unusual cost* of foreign, mathematical, and tabular material, as well as alterations made in the proof by the author, may be charged to the author.

*Author's Reprints.*—Reprints will be furnished in accordance with the following schedule of prices (approximate):

Copies	4 pp.	8 pp.	12 pp.	16 pp.	20 pp.	Covers
100	\$3.25	\$6.50	\$ 9.75	\$13.00	\$16.25	\$3.00
200	6.50	13.00	19.50	26.00	32.50	6.00
300	9.75	19.50	29.25	39.00	48.75	9.00
400	13.00	26.00	39.00	52.00	65.00	12.00

*Subscriptions* or requests for the purchase of back numbers or volumes of the JOURNAL or the PROCEEDINGS should be sent to HAROLD A. REHDER, Custodian and Subscription Manager of Publications, U. S. National Museum, Washington 25, D. C.

*Subscription Rates* for the JOURNAL.—Per year..... \$7.50

Price of back numbers and volumes:	Per Vol.	Per Number
Vol. 1 to vol. 10, incl.—not available.*	—	—
Vol. 11 to vol. 15, incl. (21 numbers per vol.)	\$10.00	\$0.70
Vol. 16 to vol. 22, incl. (21 numbers per vol.)	8.00	0.60
Vol. 23 to current vol. (12 numbers per vol.)	7.50	0.90

\* Limited number of complete sets of the JOURNAL (vol. 1 to vol. 41, incl.) available for sale to libraries at \$348.50.

MONOGRAPH No. 1, "The Parasitic Cuckoos of Africa," by Herbert Friedmann. \$4.50

PROCEEDINGS, vols. 1-13 (1899-1911) complete..... \$25.00

Single volumes, unbound..... 2.00

Single numbers..... .25

*Missing Numbers* will be replaced without charge provided that claim is made to the Treasurer within 30 days after date of following issue.

*Remittances* should be made payable to "Washington Academy of Sciences" and addressed to the Treasurer, H. S. RAPPLEYE, 6712 Fourth Street, N.W., Washington 12, D.C.

*Exchanges.*—The Academy does not exchange its publications for those of other societies.



# JOURNAL OF THE WASHINGTON ACADEMY OF SCIENCES

VOLUME 42

February 1952

No. 2

PHYSICS.—*Preliminary report: Nonlinear absorption and dispersion of plane ultrasonic waves in pure fluids.* C. TRUESDELL,<sup>1</sup> Graduate Institute for Applied Mathematics, Indiana University.

Wang Chang and Uhlenbeck (1, 2) have insisted, arguing from an expansion in powers of the ratio mean free path/wavelength, that the Navier-Stokes equations can not yield "a consistent theory" of nonlinear absorption and dispersion. They have claimed that for a monatomic gas the higher order stress and heat flux terms of Burnett and Chapman-Cowling must be employed to obtain correctly any dispersion at all and that to obtain correctly an absorption coefficient per wave-length which is a nonlinear function of frequency one must consider even higher order stresses and heat flux. Following in the footsteps of numerous predecessors, they have given the first two terms in power series expansions for the absorption and dispersion coefficients. Their mean free path argument is hardly plausible: the Navier-Stokes equations are valid also in liquids; measured absorption and dispersion in liquids is very similar qualitatively to that in gases, yet for liquids mean free path arguments are quite inapplicable. That the Navier-Stokes equations are derived by Enskog's method of integration in the kinetic theory of monatomic gases only as a low order approximation does not prove they may *not* be derived under weaker assumptions by a better method from a more general kinetic theory including liquids as well as gases: indeed, in the past an equation has often been shown to be much better than some methods of deriving it might suggest.

Greenspan (3, 4) has recently published results of experiments on rarefied helium which give some support to this view. He has compared the measured values of the

absorption coefficient with those predicted from four theoretical curves. In the region where these four curves diverge widely from one another, he finds that Wang Chang and Uhlenbeck's 2-term approximation based on as yet unpublished higher kinetic theory approximations is the worst of all; next comes the 2-term approximation from the Navier-Stokes equations; next the classical linearization of Kirchhoff; while the *exact* solution of the linearized Navier-Stokes equations fits perfectly. Discarding the 2-term expressions altogether, he then employs the exact results from the Navier-Stokes equations and the exact results from the kinetic theory expressions of Burnett and Chapman-Cowling; again he finds that the results from the Navier-Stokes equations agree markedly better with experimental values of the absorption coefficient, but the dispersion when  $\gamma p/\omega\mu < 2$  is less than that predicted by either theory.

The foregoing results suggest that the exact consequences of the Navier-Stokes equations deserve a hearing. Greenspan's theoretical curves are limited to the case  $\gamma = 5/3$ ,  $\mathcal{P} = 2/3$ ,  $\mathcal{U} = 4/3$ , where  $\mathcal{P} \equiv \mu c_p/\kappa$  is the Prandtl number and  $\mathcal{U} \equiv 2 + \lambda/\mu$  is a number representing the relative magnitudes of the two viscosity coefficients  $\lambda$  and  $\mu$ . I have thought it worth while to investigate the exact results for the entire range of values of  $\gamma$ ,  $\mathcal{P}$ , and  $\mathcal{U}$  which are experimentally measured in fluids, especially with a view to correct experimental determination of  $\mathcal{U}$ . For a pure fluid in which radiation is negligible the whole theory is contained in the characteristic equation derived for perfect gases by Kirchhoff (5) and extended to arbitrary pure fluids by Langevin (6):

<sup>1</sup> This work was done under Navy Contract N60nr-180, Task Order No. V, with Indiana University.

$$\left(\frac{\sigma}{2\pi}\right)^4 \left[ -\frac{\gamma \mathfrak{U}^2 \mathfrak{S}^2}{\rho \mathfrak{U}} + i \frac{\mathfrak{S} \mathfrak{U}}{\rho \mathfrak{U}} \right] + \left(\frac{\sigma}{2\pi}\right)^2 \left[ 1 + i \mathfrak{S} \mathfrak{U} \left( 1 + \frac{\gamma}{\rho \mathfrak{U}} \right) \right] + 1 = 0. \quad (1)$$

Here

$$\mathfrak{S} \equiv \frac{\mu \omega}{\rho V_0^2}, \quad V_0^2 \equiv \left( \frac{\partial p}{\partial \rho} \right)_\eta,$$

$\eta$  being the specific entropy. Since  $\mathfrak{S}$  was introduced by Stokes, I call it the *Stokes number*. If  $\sigma$  be a solution of (1) then the corresponding absorption coefficient per reference wavelength  $l_0 \equiv 2\pi V_0/\omega$  is  $A_0 \equiv |\Re \sigma|$ ; the true absorption coefficient per wavelength  $l \equiv 2\pi V/\omega$  is  $A \equiv 2\pi |\Re \sigma / \mathfrak{S} \sigma|$ ; the speed of propagation  $V$  is given by  $V/V_0 = 2\pi / |\Im \sigma|$ . Convenient for theoretical work is the ratio  $\mathfrak{A} \equiv A/(V/V_0)^2 = |\Re \sigma \mathfrak{S} \sigma| / 2\pi$ .

From (1) it follows that the entire phenomenon is governed by three scaling parameters, which we may choose as follows:  $\mathfrak{X} \equiv \mathfrak{S} \mathfrak{U}$ ,  $\mathfrak{z} \equiv (\gamma - 1)/\rho \mathfrak{U}$ ,  $\gamma$ . In special cases this number is reduced to  $\mathfrak{X}$  and  $\mathfrak{z}$  or even to  $\mathfrak{X}$  alone. Since for a perfect gas  $\mathfrak{X} = \mu \omega / [\gamma p (2 + \lambda/\mu)]$ , it is plain that for absorption and dispersion in such a gas increase in frequency has the same scale effect as decrease in pressure.

The simplest case is that of a piezotropic fluid:  $p = p(\rho)$ . Here  $\gamma = 1$  and equation (1) factors; the resulting exact coefficients for that one of the two pairs of solutions of (1) that represents a sound wave was given in a different form by Lamb (7), but his results are marred by an error in calculation. They should be amended to read

$$\left(\frac{V}{V_0}\right)^2 = \frac{\mathfrak{z} 2(1 + \mathfrak{X}^2)}{1 + \sqrt{1 + \mathfrak{X}^2}}, \quad \mathfrak{A} = \frac{\pi \mathfrak{X}}{1 + \mathfrak{X}^2}; \quad (2)$$

thus  $V \rightarrow \infty$  monotonically as  $\mathfrak{X} \rightarrow \infty$ , while  $\mathfrak{A}$  experiences a single maximum  $\mathfrak{A} = \pi/2$  when  $\mathfrak{X} = 1$ , falling off thereafter to zero. One may show that the curve of  $A_0$  is similar to that for  $\mathfrak{A}$ , except that the maximum value  $A_0 = \pi/\sqrt{2}$  occurs when  $\mathfrak{X} = \sqrt{3}$ . However,  $A \rightarrow \infty$  monotonically as  $\mathfrak{X} \rightarrow \infty$ .

It is interesting to compare these results formally with those of Kneser (8, 9, 10) for absorption and dispersion arising from

the internal degrees of freedom in gases. Taking account of van Itterbeck and Mariens's experimental evidence (11) that Kneser's relaxation time is inversely proportional to pressure, we may put Kneser's results into the present notation. We then find that Kneser's formula for  $\mathfrak{A}$  becomes identical with (2)<sub>2</sub> except for numerical factors, but for  $(V/V_0)^2$  Kneser obtains a finite limit  $(V_\infty/V_0)^2$  as  $\mathfrak{X} \rightarrow \infty$ . The difference in the two dispersion formulae accounts also for the difference in the formulae for  $A_0$  and  $A$ . From experimental data it is difficult to see even qualitatively which type of dispersion curve actually occurs. In any case the foregoing results show that to obtain an absorption peak it is not at all necessary to introduce molecular notions or to modify the Navier-Stokes equations. The "relaxation time" for  $A_0$  according to (2) is  $\tau = 2\pi(\lambda + 2\mu)/(\sqrt{3}\rho V_0^2)$ .

The effect of the value of  $\mathfrak{U}$  on absorption and dispersion is plain from (2). If  $\mathfrak{A}$  or  $A_0$  be regarded as functions of  $\mathfrak{S}$  for various fixed values of  $\mathfrak{U}$ , then increase in  $\mathfrak{U}$  increases the initial slope (classical absorption coefficient) but decreases the value of  $\mathfrak{S}$  at which the absorption peak occurs. Thus liquids in which  $\lambda/\mu$  is large show "relaxation" effects at much lower frequencies than if  $\lambda/\mu = -2/3$ , and their absorption peaks are sharper. Increase in the value of  $\mathfrak{U}$  always increases the dispersion.

Now in the ultrasonic literature absorption measurements in liquids are always compared with the "classical" value  $A = A_0 = \mathfrak{A} = (4/3)\pi\mathfrak{S}$  obtained by linearizing (2)<sub>2</sub> and putting  $\mathfrak{U} = 4/3$ . The correct linearized expression, allowing for bulk viscosity, is  $A = \pi\mathfrak{U}\mathfrak{S}$ . If, as has been suggested (12, 13),  $\mathfrak{U}$  is to be determined from this formula then care must be taken that all results are extrapolated to  $\mathfrak{S} = 0$ . For otherwise the nonlinearity of (2)<sub>2</sub> needs to be taken into account, especially if  $\mathfrak{U}$  is large. It is possible to get apparent agreement with the "classical" result by making two compensating errors: taking too large a value for  $A$  by linearizing (2)<sub>2</sub>, but too small a value by assigning to  $\mathfrak{U}$  its minimum,  $4/3$ .

While the piezotropic fluid serves as a first approximation to a nonmetallic liquid,

a better approximation is obtained by supposing  $\gamma \neq 1$  but  $\gamma/\mathcal{P} \ll 1$ . For the pair of solutions of (1) which as  $\gamma \rightarrow 1$  approach those appropriate to sound waves in the piezotropic case, one may show that with great accuracy the following approximate formulae hold for all values of  $\mathfrak{X}$ :

$$\left(\frac{V}{V_0}\right)^2 = \frac{2(1 + \mathfrak{X}^2)}{1 + \sqrt{1 + \mathfrak{X}^2}} \cdot \left[ 1 + \delta \frac{3 + 2\sqrt{1 + \mathfrak{X}^2} - \mathfrak{X}^2}{(1 + \mathfrak{X}^2)^2(1 + \sqrt{1 + \mathfrak{X}^2})} \right], \quad (3)$$

$$\mathfrak{A} = \frac{\pi\mathfrak{X}}{1 + \mathfrak{X}^2} \left[ 1 + \delta \frac{1 - 3\mathfrak{X}^2}{(1 + \mathfrak{X}^2)^2} \right]. \quad (4)$$

Comparison with (2) shows that a relatively slight amount of heat conduction slightly *increases* both absorption and dispersion for small  $\mathfrak{X}$ , but slightly *decreases* both for large  $\mathfrak{X}$ . In particular, the absorption peak is both *lowered* and *brought in* to a smaller value of  $\mathfrak{X}$ , for we have the maximum value  $\mathfrak{A} = (\pi/2)(1 - \mathfrak{Z}/2)$  when  $\mathfrak{X} = 1 - \mathfrak{Z}/2$ . If the experimentally measured peak in  $\mathfrak{A}$  can be accurately located, we have an excellent means of determining  $\lambda$  from the formula  $\mathfrak{U}\mathfrak{S} = 1 - \mathfrak{Z}/2$ , or, approximately,

$$\frac{\lambda}{\mu} = -2 + \frac{1}{s_m} - \frac{\gamma - 1}{2\mathcal{P}},$$

where  $s_m$  is the value of  $s$  at which resonance occurs. We have  $s_m \leq 3/4$  always, since  $s_m = 3/4$ ,  $\gamma = 1$  implies the Stokes relation  $3\lambda + 2\mu = 0$ , which gives  $\lambda$  its minimum value.

For gases it is possible to exhibit the exact coefficients but very difficult to trace their behavior as functions of  $s$ .

The second pair of solutions of (1), which when  $\gamma \rightarrow 1$  approach those appropriate to a thermal wave in a piezotropic fluid, yield a second type of waves, which if  $\gamma \neq 1$  are unavoidably produced along with the first by any source of disturbance. These have been discarded by Kirchhoff and all subsequent investigators because as  $s \rightarrow 0$  they are much more strongly absorbed than the first. It is interesting to compare the two absorption coefficients for general values of  $s$ . My results are not yet complete, but from (1) it is easy to see that as  $s \rightarrow \infty$  the two pairs of solutions approach those which would belong to a fluid in which

$p = p(\rho)$  but formally  $\gamma \neq 1$ . Perhaps the ratio of their values in general is not too far different from that for such a fictitious fluid. Denoting the absorption coefficient for the second by  $\bar{A}_0$ , we have then  $\bar{A}_0^2 = 2\pi^2 \mathcal{P}/\gamma\mathfrak{S}$ ,

$$\left(\frac{\bar{A}_0}{A_0}\right)^2 = \frac{\mathcal{P}(1 + \mathfrak{S}^2\mathfrak{U}^2)}{\gamma\mathfrak{S}[\sqrt{1 + \mathfrak{S}^2\mathfrak{U}^2} - 1]}.$$

This function is a monotone *decreasing* function of  $s$ . Hence as  $s$  grows larger, the *possibility* of observing the second type of wave *increases*. As  $s \rightarrow \infty$  we have  $\bar{A}_0^2/A_0^2 \rightarrow \mathcal{P}\mathfrak{U}/\gamma$  (and this result is valid without approximation for the fully general eq. (1)). Hence in *nonmetallic liquids*, where  $\mathcal{P}$  is large, the second type of wave will never be observed at any frequency; in *monatomic gases*, however, since  $\mathcal{P}\mathfrak{U}/\gamma = 8/15$ , at high frequencies and very low pressures the second type of wave is absorbed only about half as much as the former; while in *metallic liquids*, where  $\mathcal{P}$  is small, the second type of wave will altogether predominate for large values of  $s$ , unless perchance  $\mathfrak{U}$  be large.

In a memoir now in preparation I shall give accurate graphs of all coefficients for  $0 \leq \mathfrak{X} \leq 4$  and for all values of the parameters  $\gamma$  and  $\mathfrak{Z}$  which are found in actual fluids. I shall also attempt to compare these results with experimental data and thence, in particular, to determine reliable values for  $\mathfrak{U}$  in common pure fluids

#### REFERENCES

- (1) WANG CHANG, C. S., and UHLENBECK, G. E. *On the transport phenomena in rarefied gases.* APL/JHU CM-443, UMH-3-F. Feb. 20, 1948.
- (2) WANG CHANG, C. S. *The dispersion of sound in helium.* APL/JHU CM-467, UMH-3-F. May 1, 1948.
- (3) GREENSPAN, M. *Phys. Rev.* (2) **75**: 197-198. 1949.
- (4) ———. *Journ. Acoust. Soc. Amer.* **22**: 568-571. 1950.
- (5) KIRCHOFF, G. *Ann. Physik* **134**: 177-193. 1868 (= *Gesammelte Abhandlungen* **1**: 540-556).
- (6) BICQUARD, P. *Rév. d'Acoustique* **1**: 93-109. 1932.
- (7) LAMB, H. *A treatise on the mathematical theory of the motion of fluids.* Cambridge, 1879. (See §183. This material was omitted in later editions.)
- (8) KNESEER, H. *Ann. Physik* (5) **11**: 761-776. 1931.
- (9) ———. *Ann. Physik* (5) **16**: 337-399. 1933.

- (10) ——. *Ergebn. Exakten Naturwiss.* **22**: 121-185. 1949.
- (11) VAN ITTERBECK and MARIENS. *Physica* **5**: 153-160. 1938.
- (12) MANDELSTAM, L., and LEONTOVIČ, M. C. R. *Doklady Acad. Sci. SSR* (2) **3**, 111-114. 1936.
- (13) TISZA, L. *Phys. Rev.* (2) **61**: 531-536. 1942.

MINERALOGY.—*The nature of rock phosphates, teeth, and bones.* DUNCAN McCONNELL, Ohio State University, Columbus, Ohio. (Communicated by W. F. Foshag.)

In order to understand the chemistry of rock phosphates it is essential to realize what minerals are likely to be present in these rocks (1). One must consider also that very few minerals have rigorously fixed compositions because they are subject to isomorphic variations. For example, one of the commonest mineral substances, plagioclase feldspar, may be a sodium aluminum silicate (albite) or a calcium aluminum silicate (anorthite), but the commonest varieties are intermediate in composition. When considering the chemical analysis of an intermediate variety of plagioclase, it is usually not possible to set down a simple formula, but one can indicate, nevertheless, the relative percentages of  $\text{NaAlSi}_3\text{O}_8$  and  $\text{CaAl}_2\text{Si}_2\text{O}_8$ , which are the theoretical end members of the isomorphic series. If one attempts to calculate from the chemical analysis of a rock the amount and variety of feldspar present, he faces an impossible task if other mineral constituents containing  $\text{Na}_2\text{O}$ ,  $\text{CaO}$ , and  $\text{SiO}_2$  also are present and their amounts and compositions likewise are unknown.

The situation is similar when considering rock phosphates; the composition of the principal mineral constituent cannot be determined from the analysis of the rock unless the kinds and quantities of other minerals present can be determined accurately. Therefore, it becomes impossible to ascertain the types of isomorphic variation of the minerals, francolite, dahllite, etc., from even the most precise data obtained on heterogeneous substances such as phosphorites.

The "mineral phase" of tooth and bone has been shown to be an apatitelike substance and, to this extent, it is similar to phosphorite. It differs from most phosphorites, however, in its low fluorine content. The substance of tooth and bone is not

composed entirely of this apatitelike substance; it contains organic compounds in addition. Were it possible to remove the organic substances without in any way altering the inorganic material, it would be possible to study the crystal chemistry of the "mineral phase." Insofar as present knowledge is concerned, one of the important constituents of the "mineral phase" may be water (2), which occurs in combined form in the crystallites. No method that will remove the organic matter from teeth and bones without danger of altering the water content of the apatitelike substance has ever been described. Here again is the same situation: neither the kinds nor quantities of the other constituents are known. Therefore, quantitative study of the isomorphic variation of the apatite phase cannot be accomplished by experimentation on the whole substance of teeth and bones.

The exceedingly important difference between the chemical compositions of ordinary fluorapatite and the substances of teeth, bones, and phosphorites is the universal presence of significant amounts of carbon dioxide in the latter substances. Therefore, considerable interest has arisen in pure mineral substances which contain carbon dioxide and produce diffraction patterns similar to fluorapatite. Francolite is the best known of these substances; it occurs at several widely separated localities, but remarkable similarities between samples from Germany (3) and South Africa (4) exist. The mineral dahllite is similar to francolite except that it contains less than one percent fluorine (5). Lewistonite and dehrnite are similar in that they may contain carbon dioxide but are different to the extent that they contain potassium and sodium, respectively.

Details concerning the isomorphic substitutions which can occur in the apatite

lattice need not be considered here. Substitutions for calcium include K, Na, Mn, Mg, Sr, and Ba. Substitutions for phosphorus include Si, S, V, Cr, and probably aluminum. Such compounds as  $\text{Ca}_{10}(\text{OH})_2(\text{SiO}_4)_3(\text{SO}_4)_3$  and  $(\text{Na}_6\text{Ca}_4)\text{F}_2(\text{SO}_4)_6$  clearly indicate the extensive possibilities for isomorphic substitution (6, 7). Recognizing this extensive tolerance of the apatite structure for isomorphic substitution, one can return to the question of the sorts of isomorphic substitution in francolite.

In viewing the chemical nature of francolite, five recent analyses by well-qualified analysts are available. One quickly discovers that the Ca:P:C ratios are not uniform. This fact is no more surprising, however, than the fact that the ratios Na:Ca:Al of plagioclase feldspar are not constant. Nevertheless, the compounds  $\text{Ca}_{10}\text{CO}_3(\text{PO}_4)_6$  has been assumed as a theoretical end member for the purpose of calculating the composition of dental enamel, and these calculations have been made within the past few years, completely disregarding the fact that Gruner and McConnell (3) disproved the existence of this compound in 1937.

The variation in Ca:P:C has been taken to indicate that francolite is composed of two phases. Although this conclusion by no means follows as a logical sequence to the principles of isomorphism, one might ask whether or not any other evidences for the presence of two phases exist. In view of the water-clear condition of the francolite crystals, the proponents of the 2-phase hypothesis are forced to call upon "submicroscopic" or "colloidal" particles of  $\text{CaCO}_3$  distributed throughout the francolite. This explanation is unique in its application to francolite, and several incompatibilities arise from consideration of the data. If francolite were composed of fluorapatite and  $\text{CaCO}_3$ , one could obtain the correct stoichiometry for fluorapatite merely by deducting equivalents of CaO and  $\text{CO}_2$  from the analyses of francolite. This is by no means the case, however, and the discrepancies which occur probably exceed the experimental error in each instance (2).

Far more important, however, is the fact that the unit-cell dimensions of francolite and fluorapatite differ by amounts which

far exceed the experimental error for these measurements (2). X-ray diffraction data obtained by use of the Philips high-angle spectrometer indicate, furthermore, that significant intensity differences also exist. In the absence of any explanation of how the so-called colloidal particles of  $\text{CaCO}_3$  could possibly alter the diffraction pattern of apatite in this way, it becomes necessary to conclude that the crystal lattice of francolite is somewhat different from that of the fluorapatite and these differences are the cause of the X-ray diffraction phenomena.

Recently, Hendricks and Hill (8) have obtained an explanation based upon absorption of nitrogen by francolite. They conclude that certain surfaces exist within francolite crystals and that these "discontinuities" are capable of adsorbing carbonate. The physical analogy is not quite clear but apparently the "carbonate" is believed to be present in the form of ions which are brought to electrical neutrality by cations in the structural arrangement. Further scrutiny will indicate that they postulate a new type of disordering in crystals in which part of the atoms are in the lattice and part are present at discontinuities. One can not predict how such a process could be detected by crystallographic methods, and Hendricks and Hill do not clarify the matter, but here again is a hypothesis that seems to have francolite as an unique example.

It is noticeable that they calculate 61  $\text{m}^2/\text{g}$ . as the "surface" of francolite whereas the highest experimental value is 7.3  $\text{m}^2/\text{g}$ . and no comment appears in explanation of this significant discrepancy. One can extend their method of calculation in order to obtain the periodicity of interruption of a solid system with regular 3-dimensional coordinates. Under these circumstances, the average spacing of the discontinuities would be 315 Å. What the effect of discontinuities of this spacing would be on the X-ray diffraction pattern is difficult to predict without a more reliable knowledge of the true nature of these discontinuities. Nevertheless, it can be assumed that such a condition would not merely alter the spacings and intensities without in any way altering the excellency of resolution of the diffraction lines. In this

connection it is noteworthy that although bone produces broad and diffuse diffraction lines, the lines of francolite are essentially as sharp and distinct as those of fluorapatite (2).

Quite in contrast with some of the explanations discussed above, stand attempts to seek an explanation of the crystal lattice of francolite in terms of the principles of isomorphic substitution. That knowledge of all of these principles is not presently available can safely be admitted. Nevertheless, it is possible through slight extension of well recognized principles to obtain a structural model which has two important properties (2). It is capable of qualitative alteration of the intensities of prismatic diffraction maxima as well as the birefringence. Both values are observed to increase for francolite when compared with fluorapatite. Quantitative comparisons cannot be obtained readily because of limitations imposed by an inexact knowledge of the precise atomic coordinates for pure apatite. No reliable integrated intensity measurements for an analyzed sample of apatite have been published and therefore the published coordinates cannot claim great precision.

Although Bale (9) claims to have refined the coordinates for one type of calcium position by small percentages of the cell edge, his crystal of apatite apparently was not analyzed, so his results are quite meaningless. Beevers and McIntyre (10) stated that they were able to obtain highly refined coordinates for the atoms in apatite but neither did they give their newly determined coordinates nor did they indicate that analyzed material was used. Their principal contribution, consequently, was a series of colored diagrams which explain the well known structures proposed by NÁRAY-SZABÓ (11) and by Mehmel (12).

Properties of francolite other than those which can be measured by X-ray diffraction should also be mentioned briefly. The birefringence of francolite exceeds that of fluorapatite (13), francolite is usually biaxial and may have an optic angle as large as  $40^\circ$  (14, 15), and the mean refractive index of

francolite is less than that of fluorapatite (13). In summary on the properties of francolite, one concludes that all the crystallographic properties are different from those of fluorapatite and that adsorption or the presence of colloidal impurities apparently are incapable of explaining these differences.

Returning to teeth, bones, and phosphorite one concludes: (1) The physical and chemical properties of these substances are largely dependent upon the properties of francolite or dahllite, and (2) the properties of these heterogeneous substances cannot be expected to reveal the isomorphic nature of francolite or dahllite. Concerning francolite these additional conclusions obtain: (3) Direct study of the chemical and physical properties has resulted in an explanation of the crystal structure of francolite which appears to be consistent qualitatively with all of the observed data, (4) quantitative confirmation of the proposed structure for francolite will require additional data, which will be difficultly obtainable for several reasons, and (5) the assumption of adsorptive processes or mechanical admixtures will not account for the experimental data on francolite.

#### REFERENCES

- (1) McCONNELL, D. *Journ. Geol.* **58**: 16. 1950.
- (2) ———. *Bull. Soc. Franç. Min. Crist.* (In press.)
- (3) GRUNER, J. W., and McCONNELL, D. *Zeitschr. Krist.* **97**: 208. 1938.
- (4) DEVILLIERS, J. E. *Amer. Journ. Sci.* **240**: 443. 1942.
- (5) McCONNELL, D. *Amer. Min.* **23**: 1. 1938.
- (6) ———. *Amer. Min.* **22**: 977. 1937.
- (7) KLEMENT, R. *Naturwiss.* **33**: 568. 1939.
- (8) HENDRICKS, S. B., and HILL, W. L. *Proc. Nat. Acad. Sci.* **36**: 732. 1950.
- (9) BALE, W. F. *Amer. Journ. Roentgen. Radium Therapy* **43**: 735. 1940.
- (10) BEEVERS, C. A., and McINTYRE, D. B. *Min. Mag.* **27**: 254. 1945.
- (11) NÁRAY-SZABÓ, S. *Zeitschr. Krist.* **75**: 387. 1930.
- (12) MEHMEI, M. *Zeitschr. Krist.* **75**: 323. 1930.
- (13) McCONNELL, D., and GRUNER, J. W. *Amer. Min.* **25**: 135. 1938.
- (14) HUTTON, C. O., and STEELYE, F. T. *Trans. Roy. Soc. New Zealand* **72**: 191. 1942.
- (15) DEANS, T., and VINCENT, H. C. G. *Min. Mag.* **25**: 135. 1938.

**BOTANY.**—*Notes on some families of Formosan phanerogams.* HUI-LIN LI, National Taiwan University, Taipei, Taiwan, China. (Communicated by A. C. Smith.)

These notes are the result of critical studies on selected families of Formosan flowering plants, namely, Juglandaceae, Ulmaceae, Lardizabalaceae, Beberidaceae, and Saxifragaceae. Most of the species of plants described from this island by botanists have been proposed without adequate consideration of the neighboring and closely related floras, except for that of Japan. We now realize that the flora of Formosa is more closely related to the flora of mainland China than to that of any other region; numerous mainland species are represented in Formosa by their typical form or by a variation. Both the lowland and the montane floras of the island show intimate kinship with those of the mainland, the relationship in the former case being especially with southern China and in the latter case particularly with the highlands of western China. The flora of Formosa also shows close relationships with that of the Philippine Islands, especially as regards the southern species and to a certain extent also the montane species. In order properly to interpret the identity, nature, and range of Formosan species, it is therefore essential to consult closely all the neighboring floras.

Large series of specimens from mainland China, Hainan, the Philippines, the Liukius, and Japan now being available to the present writer, careful studies of selected families of Formosan plants show that considerable alterations in our concept of some species are necessary. In the present paper, three new species, one new variety, and one new form are proposed, three new combinations are effected, and one new record is indicated. Twelve names are found to represent synonyms of previously described species and reductions are accordingly made. Several binomials, relegated to synonymy by former authors, are reinstated as distinct entities. These findings will serve to indicate what we may expect as we review the Formosan flora in particular and the eastern Asiatic flora in general.

The materials used are those of the herbarium of the National Taiwan Univer-

sity (indicated as NTU) and the U. S. National Herbarium (US). Only selected specimens are cited from the former herbarium.

This paper was prepared in the Department of Botany of the U. S. National Museum, with the aid of a grant from the U. S. Department of State. The writer is indebted to the American Philosophical Society for an earlier grant which gave him an opportunity to study Formosan plants in the field and in some Chinese herbaria. To Dr. A. C. Smith, grateful acknowledgment is due for his kindness in reading the manuscript.

#### JUGLANDACEAE

*Engelhardtia chrysolepis* Hance in Ann. Sci. Nat. IV. 15: 227. 1861.

*Engelhardtia formosana* Hay. Icon. Pl. Formos. 6: 61. 1916; Kanehira, Formos. Trees rev. ed. 80. f. 36. 1936. *Syn. nov.*

*Engelhardtia spicata* Blume var. *formosana* Hay. in Journ. Coll. Sci. Tokyo 25 (19): 199. 1908 (Fl. Mont. Formos.). *Syn. nov.*

FORMOSA: Mount Noko, H. H. Bartlett 6158 (US); Baibara Nokogun, S. Sasaki Aug. 27, 1924 (NTU).

Southern China. In Formosa, common in broad-leaved forests throughout the island.

The Formosan plant is identical with the mainland species, which is widely distributed from northern India through western to southern China. The species shows some variation. When herbarium specimens from various regions are compared, the Formosan ones are similar particularly to those from Hainan Island.

*Juglans cathayensis* Dode in Bull. Soc. Dendr. France 1909: 47. f. 1909.

*Juglans formosana* Hay. in Journ. Coll. Sci. Tokyo 30 (1): 283. 1911 (Mat. Fl. Formos.); Kanehira, Formos. Trees rev. ed. 82. f. 36. 1936. *Syn. nov.*

FORMOSA: Kaunko, Kwarenko, E. H. Wilson 11152 (US).

Widely distributed in China. In Formosa, scattered in forests at 1,200–2,000 meters.

Hayata originally described the Formosan plant as a distinct species and compared it with

*J. cordiformis* Maxim. and *J. sieboldiana* Maxim. of Japan. Actually the plant is identical with *J. cathayensis* Dode, a species of wide distribution on the Chinese mainland, and the two are evidently conspecific.

**Platycarya strobilacea** Sieb. & Zucc. in Abh Math.-Phys. Kl. Akad. Wiss. Münch. 3: 741. 1843.

*Platycarya strobilacea* var. *kawakamii* Hay. in Journ. Coll. Sci. Tokyo 30 (1): 284. 1911 (Mat. Fl. Formos.). *Syn. nov.*

*Petrophiloides strobilacea* var. *kawakamii* (Hay.) Kanehira, Formos. Trees rev. ed. 82. f. 37. 1936.

China to Japan. In Formosa, in forests at medium altitudes in the northern part of the island.

FORMOSA: Seisui, Kwareenko, Kanehira & Sasaki 7264 (US, photo).

Hayata proposed the Formosan entity as a variety, stating that it "Differs from the type in having much smaller leaflets, and narrower cones with a little broader bracts." These differences, shown by a single specimen, do not actually differentiate the Formosan plant as a distinct variety. It does not differ significantly from plants of the Chinese mainland and Japan, which exhibit considerable variation in all parts of the plant.

#### ULMACEAE

**Trema virgata** (Roxb.) Blume, Mus. Bot. Lugd.-Bat. 2: 58. 1856; Hand.-Mazz. Symb. Sin. 7: 106. 1929.

*Celtis virgata* Roxb. in Wall. List n. 3694. 1828-49.

Southern China. New record for Formosa.

FORMOSA: Sintin, Taihoku-syu, K. Odashima 13605 (US).

**Ulmus uyematsui** Hay. Icon. Pl. Formos. 3: 174. pl. 32. 1931; Kanehira, Formos. Trees rev. ed. 143. f. 90. 1936.

Endemic. In forests of the central mountains at altitudes of 1,500-2,000 meters.

FORMOSA: Arisan, E. H. Wilson 9684 (US).

*Ulmus uyematsui* Hay. is apparently endemic to Formosa. Handel-Mazzetti (Symb. Sin. 7: 100. 1931) doubtfully refers several collections from mainland China to this species. One of these, *Ching 2194a*, from southern Chekiang (US), is available. This specimen bears leaves that are distinctly cordate at base, densely appressed-

pubescent beneath, simple serrate at margins, and with more than 20 lateral veins per side; it is very clearly distinct from *U. uyematsui*.

**Zelkova serrata** (Thunb.) Makino in Bot. Mag. Tokyo 17: 13. 1903.

*Zelkova formosana* Hay. Icon. Pl. Formos. 9: 104. f. 33, 1 & 2. 1920; Kanehira, Formos. Trees rev. ed. 144. f. 91. 1936. *Syn. nov.*

Eastern China to Japan. Formosa, in forests at about 1,000-2,000 meters.

FORMOSA: Musha, E. H. Wilson 10102 (US); no locality, Taiwan Univ. Herb. (NTU).

*Zelkova formosana* was noted by both Hayata and Kanehira as very close to *Z. serrata*, differing only in the smaller leaves. However, the leaves of Formosan plants are about the size of the normal leaves of Japanese and Chinese plants, which sometimes may bear much larger ones on sprouting shoots. As there is no other single character to support its differentiation, *Z. formosana* is here reduced to the synonymy of *Z. serrata*.

**Zelkova serrata** (Thunb.) Makino var. **tarokoensis** (Hay.) comb. nov.

*Zelkova tarokoensis* Hay. Icon. Pl. Formos. 9: 104. f. 33, 3 & 4. 1920.

Endemic to the eastern coast of Formosa.

FORMOSA: Taitotyo, Sinkogun, T. Suzuki 19728 (NTU).

Kanehira (loc. cit.) treated this entity as a straight synonym of *A. formosana* (= *Z. serrata*) but noted its small leaves with fewer veins. The leaves are also much less sharply serrate and are totally glabrous. It appears as a distinct but very localized variety.

#### LARDIZABALACEAE

**Stauntonia hexaphylla** (Thunb.) Decaisne f. **rotundata** Wu in Notizbl. Bot. Gart. Berlin 13: 369. 1936.

*Stauntonia obovatifoliolata* Hay. Icon. Pl. Formos. 8: 4. f. 3, 1-6. 1919; Kanehira, Formos. Trees rev. ed. 180. 1936. *Syn. nov.*

Japan, Liukiu. Formosa, in central mountains. FORMOSA: Musya, Nanto, T. Kawakami 9882 (US, photo).

Wu, without seeing the type, reduced *S. obovatifoliolata* together with *S. obovatifoliolata* var. *penninervis* Hay. to the synonymy of *S. hexaphylla* f. *obovata* Wu. Photographs of Hayata's types show that the two are different and the former should be referred instead to f. *rotundata*.



**Stauntonia hexaphylla** (Thunb.) Decaisne f. **cordata** f. nov.

A typo speciei foliolis distincte cordatis differt; foliolis ovato-oblongis vel oblongo-lanceolatis, 5-7.5 cm longis, 2-2.7 cm latis, apice caudato-acutis, basi distincte cordatis.

Formosa, in forests between Yappitu and Dozan, Taihoku-syu, *T. Suzuki 8751*, April 17, 1933 (NTU, type).

**Stauntonia obovata** Hemsley in Hook. Icon. Pl. 29: pl. 2847. 1907.

*Stauntonia hebandra* Hay. Icon. Pl. Formos. 8: 3. f. 2. 1919; Kanehira, Formos. Trees rev. ed. 180. 1936; Wu in Notizbl. Bot. Gart. Berlin 13: 375. 1936. *Syn. nov.*

Southern China to Formosa.

FORMOSA: Karapin and Funkiko, *B. Hayata 9875* (US, photo of isotype).

Hayata differentiated his species from *S. obovata* Hemsley by the obtuse or emarginate anthers. In *S. obovata* the anthers are very shortly apiculate, the spur attaining a length of hardly 1 mm. Hayata's illustration shows that the anthers of his plant vary from nonapiculate to shortly but distinctly apiculate. Undoubtedly the Formosan plant is conspecific with the Chinese mainland species.

**Stauntonia obovata** Hemsley var. **angustata** (Wu) comb. nov.

*Stauntonia hebandra* Hay. var. *angustata* Wu in Notizbl. Bot. Gart. Berlin 13: 375. 1936.

Endemic, common in thickets of central mountains.

FORMOSA: Horisha, Nanto, *E. H. Wilson 9949* (US, isotype).

## BERBERIDACEAE

**Mahonia morrisonensis** Takeda in Notes Bot. Gard. Edinb. 6: 239. pl. 36, f. 200-206. 1917.

Endemic to Formosa, in forests on central ranges, rare, at about 2,500 meters.

FORMOSA: Matsuyama, prov. Kagi, *E. H. Wilson 9816* (US).

Kanehira (Formos. Trees rev. ed. 184. 1936) reduced *M. morrisonensis* Takeda to the synonymy of *M. oiwakensis* Hay., as a result of his examination of the types. However, a photograph of Takeda's isotype (*Kawakami & Mori 9941*, US), although showing only a few leaves, definitely indicates that the plant is distinct from

Hayata's species. It is readily distinguished by the fewer leaflets, which are larger, much broader, more falcate in shape, and with more teeth on the margins. The terminal leaflet, instead of being the largest one as in *M. japonica* and *M. oiwakensis*, is among the smallest.

Takeda mentioned at the same time a specimen collected by U. Mori on Mount Morrison, which he left undetermined, as having about twelve pairs of leaflets which are thicker, hardly falcate, and with less numerous teeth; he believed it might represent a new species. These characters, however, clearly demonstrate that the specimen in question belongs to *M. oiwakensis* Hay.

**Berberis formosana** sp. nov.

Frutex parvus; ramulis novellis gracilibus, leviter cinereis, angularibus, conspicue sulcatis; foliis spinescentibus 2- vel 3-aristatis, spinis 1-1.5 cm longis; foliis normalis 2- vel 3-verticillatis, chartaceis, brevi-petiolaris, oblongo-lanceolatis, 1.5-3 cm longis, 0.6-1.2 cm latis, apice acutis vel mucronulato-apiculatis, basi acutis vel obtusis, margine subintegris vel spinoso-serratis, spinis utrinsecus ad 6, gracilibus, ad 1 mm longis, adpresso-adscedentibus, utrinque glabris, supra viridibus vel leviter glaucis, subtus leviter atris plus minusve nitidis, costa supra impressa subtus valde elevata, venis secundariis utrinsecus 5-7, supra inconspicuis, subtus leviter elevatis, ad marginem distincte anastomosantibus; petiolis haud 1.5 mm longis; floribus ignotis; fructibus immaturis 2-6-fasciculatis, ovoideis, ad 4 mm longis et 2 mm crassis, atro-cyanis, distincte glaucis, apice stigmatibus coronatis.

FORMOSA: Mountains near Muroroahu, Taihoku-syu, *T. Suzuki 7258*, July 17, 1932 (NTU, type).

This distinct species has chartaceous leaves like those of *B. morrisonensis* Hay., but it is readily distinguished by the shape of the leaves and the inconspicuous venation. It also has more fruits and these are elongated. It is a moss-clad plant of the high mountains, with slender branches. In its leaves, which have a pale subglaucous upper surface and a dark more or less shining lower surface, it is very different from all other Formosan species of the genus.

**Berberis alpicola** C. Schneider in Rep. Sp. Nov. 46: 253. 1931.

Endemic in Formosa, common on Mount Arisan at stream-sides at 3,600 meters.

FORMOSA: Arisan, *E. H. Wilson 10952* (US, isotype).

This species is characterized by its small shining leaves with strong spreading spines at the margins. It is apparently very close to *B. kawakamii* Hay., as the type collection was first identified by Byhouwer (in Journ. Arnold Arb. **9**: 133. 1928) as representing that species. Yojira Kimura, in Journ. Jap. Bot. **16**: 58. 1940, considered *B. alpicola* (as "*alpicora*") Schneider as a synonym of *B. morrisonensis* Hay., basing his conclusion on the original description. This placement is erroneous, as the type collection shows *B. alpicola* to be very different from the rather distinct *B. morrisonensis* Hay., although very close to *B. kawakamii* Hay.

**Berberis brevisepala** Hay. Icon. Pl. Formos. **3**: 14. 1913; Kanehira, Formos. Trees rev. ed. 182. 1936.

*Berberis densifolia* Byhouwer in Journ. Arnold Arb. **9**: 133. 1928; Kanehira, Formos. Trees rev. ed. 182. 1936; non Rusby. *Syn. nov.*

*Berberis nantoensis* C. Schneider in Rep. Sp. Nov. **46**: 252. 1939. *Syn. nov.*

Endemic to Formosa, high central mountains, over 3,500 meters.

FORMOSA: Mount Kirai-shui, prov. Nanto, *E. H. Wilson 10074* (US, isotype of *B. densifolia* Byhouwer).

A photograph of the isotype of *B. brevisepala*, *U. Mori*, April 1910 (US, photo), is available. Hayata's original description does not discuss the flower or fruit. The flowers are 7- or 8-fasciculate, with pedicels about 1 cm. in length. The fruit is ovoid, to 9 mm long and 5 mm across, dark bluish black, and more or less glaucous. The densely leafy habit and the thickly coriaceous leaves with strongly recurved margins are very characteristic. *Berberis densifolia* Byhouwer, based on a smaller-leaved specimen, is apparently referable to this same species. Kanehira did not have access to the type, nor did he notice the name *B. nantoensis* C. Schneider given to this same plant.

#### SAXIFRAGACEAE

**Hydrangea lobbii** Maxim. in Mém. Acad. Sci. St. Pétersb. VII. **10**: 15. 1867.

*Hydrangea macrosepala* Hay. Icon. Pl. Formos. **3**: 108. 1913; Kanehira, Formos. Trees rev. ed. 244. f. 187. 1936. *Syn. nov.*

Philippine Islands. In Formosa, widely distributed in lower forests.

FORMOSA: Kotosho, *T. Hosokawa 9887* (NTU); *Kasho, Y. Kudo & K. Mori 241* (NTU).

This species, widely distributed in Formosa and known as *H. macrosepala* Hay., is the same as *H. lobbii* Maxim., of wide distribution in the mountains of the Philippines. The obscurely denticulate leaves and the prominent sepals on the fruit are very characteristic.

**Deutzia pulchra** Vidal, Revis. Pl. Vasc. Filip. **124**. 1886; Rehder in Sarg. Pl. Wils. **1**: 18. 1911; Turhill in Bot. Mag. **148**: pl. 8962. 1923; Kanehira, Formos. Trees rev. ed. 238. f. 179. 1936.

*Deutzia taiwanensis* Hay. in Journ. Coll. Sci. Tokyo **30** (1): 132. 1911. (Mat. Fl. Formos.); Hay. Icon. Pl. Formos. **1**: pl. 33. 1911, 2: 8. 1912; non Schneider.

*Deutzia pulchra* Vidal. var. *formosana* Nakai in Bot. Mag. Tokyo **35**: 84. 1921.

*Deutzia hayatai* Nakai in Bot. Mag. Tokyo **35**: 83. 1921.

*Deutzia bartlettii* Yamamoto, Suppl. Icon. Pl. Formos. **4**: 16. f. 10. 1928.

Mountains of northern Luzon and Formosa.

FORMOSA: Mount Arisan, *E. H. Wilson 9742* (US); Parsha, prov. Giran, *E. H. Wilson 10126* (US); Mt. Noko, *H. H. Bartlett 6133* (US), *6244* (US), *Kanehira & Sasaki 21712* (US); Kando & Rikiki, Takao-syu, *T. Suzuki 7881* (NTU); Mt. Morrison, *H. H. Bartlett 6312* (US, isotype of *D. bartlettii* Yamamoto).

The Formosan plant is manifestly the same as the plant found in the mountains of northern Luzon. Rehder noted a slight difference in the number of rays of the stellate hairs when he compared a single specimen from Formosa with another from Luzon. Nakai considered the Luzon plant as having more acuminate leaves and the calyx-lobes "late ovati" instead of "late depresso-ovati." However, when the Formosan specimens are compared with a large series of Luzon plants, such differential characters seem inconsequential. Kanehira is thus correct in not recognizing the Formosan plant as a distinct variety. He also reduced *D. hayatai* Nakai, based on *Kawakami & Nakahara 988*, from Kotosho (Botel Tabago), which conclusion is similarly justified.

**Deutzia cordatula** sp. nov.

Frutex, ramulis tenuibus, angularibus, dense fulvo-tomentosis, tomento stellato; foliis chartaceis, ovatis, 4.5-8 cm longis 2-3.8 cm latis,

apice acutis, basi cordatulis, margine leviter scabridis, subtus pallidis, stellato-villosis, costa venisque dense fulvo-stellato-tomentosis, supra leviter impressis, subtus distincte elevatis, venis secundariis utrinsecus 5 vel 6, arcuato-adscedentibus, ad marginem anastomosantibus; petiolicis brevibus haud 2 mm longis, stellato-tomentosis; inflorescentiis parvis paniculatis, ramulis terminalibus, ad 5.5 cm longis, dense fulvo-stellato-tomentosis; pedicellis 2-4 mm longis; calyce campanulato, tubo circiter 3 mm diametro, extus dense fulvo-stellato-tomentoso, lobis minutis, triangularibus, acutis; petalis oblongis, circiter 8 mm longis et 3-4 mm latis, subobtusis; staminibus 10, inequalateralibus, filamentis 5-7 mm longis; stylis 4, distinctis, 6-7 mm longis, apice dilatatis, indistincte 2-lobatis; ovario 4-loculari; ovulis numerosis.

FORMOSA: Mount Kwanonzan, Taihoku-syu, N. Fukuyama & S. Miura 14, April 29, 1940 (NTU, type).

This very distinct species is strongly characterized by the densely tomentose habit, the cordulate, short-petiolate leaves, and the narrow, racemelike inflorescence. It suggests no close relationships with other species but perhaps can be remotely associated with *D. sieboldii* Koern., of Japan.

*Itea parviflora* Hemsley in Ann. Bot. 9: 153. 1895; Kanehira, Formos. Trees rev. ed. 246. f. 189. 1936.

Considerable confusion exists concerning the classification of the genus *Itea* in Formosa. *Itea parviflora* Hemsley was described in 1895, from materials procured at the southern tip of the island. The species *I. chinensis* Hook. & Arnott was recorded by Henry in 1896, and later by Matsumura & Hayata and others from the northern part of the island. Hayata described *I. arisanensis* in 1916, basing it on materials from the central part of the island. In 1932 Masamune treated this as a variety of *I. chinensis*. In Kanehira's treatment of Formosan trees in 1936, he listed *I. chinensis*, *I. parviflora*, and *I. arisanensis* as present in Formosa. In 1937, Yamamoto made a special review of the genus in Formosa, listing *I. chinensis*, *I. parviflora*, and *I. arisanensis* and at the same time describing two varieties, var. *longifolia* and var. *parvifolia* under the last species. Migo, in 1944, considered *I. arisanensis* Hay. as a synonym of *I. chinensis*.

Apparently none of the Japanese authors has

had a chance of examining isotypes of Henry's *I. parviflora*, and consequently this species was much misunderstood. Yamamoto emphasized the size of flowers and differentiated the three species by slight differences in floral diameter. This character actually is not constant, as flowers on the same plant may vary in their diameter according to age. Furthermore, the plant with coriaceous leaves found in northern Formosa is in reality different from *I. chinensis* of mainland China and is here proposed as a new species. Yamamoto's *I. arisanensis* var. *longifolia* is the same as the typical form of *I. parviflora* Hemsley. The type specimen of *I. parviflora* Hemsley shows slight tufts of hairs in the nerve-axils on the lower surface of the leaves, like the plant depicted by Yamamoto. His *I. arisanensis* var. *parvifolia*, showing a similar kind of hairs but with broader leaves, belongs to *I. parviflora* var. *latifolia* as here proposed. "*Itea parviflora*" of Yamamoto presumably also belongs here, although his drawing does not show the tufts of hairs in the nerve-axils, but these hairs are very few and thin and sometimes are not present in older leaves. The leaves of *I. arisanensis* are oblong and large and they have 7 or 8 nerves per side instead of 5 or 6 as described and depicted by Yamamoto. This entity was made into a variety of *I. chinensis* by Masamune, but it is a different plant from *I. chinensis* and the actual presence of the latter in Formosa is questionable. *Itea arisanensis* is closely related to *I. parviflora* and is best treated as a variety.

The following key serves to differentiate the Formosan species and varieties of the genus *Itea*:

- A. Leaves membranaceous, the margins entire to crenate-serrulate.
- B. Leaves lanceolate, 8-12 cm long, 2.5-3.5 cm broad; nerves 5 or 6.
  - I. parviflora* var. *parviflora*
  - BB. Leaves ovate, 9-10 cm long, 4-5 cm broad; nerves 5 or 6. . . . . *I. parviflora* var. *latifolia*
  - BBB. Leaves elliptic, 10-14 cm long, 3-5 cm broad; nerves 7 or 8.
    - I. parviflora* var. *arisanensis*
    - AA. Leaves coriaceous, ovate, the margins with few to several large teeth. . . . . *I. formosana*

*Itea parviflora* Hemsley var. *parviflora*.

Endemic in Formosa, widely distributed in forests.

FORMOSA: South Cape, A. Henry 1322 (US, cotype coll.), 1980 (US); Bankensung, A. Henry

1486 (US); Gu-kutsu, Kwareenko, *E. H. Wilson 11069* (US); Sozan, Taihoku, *E. H. Wilson 10722* (US), *T. Tanaka & Y. Shimada 11040* (US).

***Itea parviflora* Hemsley var. *latifolia* var. nov.**

*Itea parviflora* sensu Yamamoto in Acta Phytotax. Geob. 6: 248. f. 2. 1937, non Hemsley.

*Itea arisanensis* var. *parvifolia* Yamamoto loc. cit. 248. f. 3d. 1937. *Syn. nov.*

A typo speciei differt foliis latoribus; foliis membranaceis, ovatis, 9–10 cm longis, 4–5 cm latis, apice acutis vel acuminatis, basi late acutis, margine creanato-serrulatis, nervis secundariis utrinsecus 5 vel 6.

Formosa: Bankensing, *A. Henry 550* (US 455805, type), *548* (US).

***Itea parviflora* Hemsley var. *arisanensis* (Hay.) comb. nov.**

*Itea arisanensis* Hay. Icon. Pl. Formos. 6: 19. 1916; Kanehira, Formos. Trees rev. ed. 246. 1936.

*Itea chinensis* var. *arisanensis* Masamune ex Kudo & Masamune, in Ann. Rep. Taihoku Bot. Gard. 2: 117. 1932.

Formosa, central mountains at an altitude of about 1,300 meters.

FORMOSA: Mount Suibarai, Tikuto-gun, Sintiku-syu, *T. Suzuki 20232* (NTU).

***Itea formosana* sp. nov.**

*Itea chinensis* sensu Henry in Trans. Asiat. Soc. Jap. 24. Suppl.: 41. 1896; Matsum. & Hay. in Journ. Coll. Sci. Tokyo 22: 133. 1906; Hay. Icon. Pl. Formos. 2: 10. 1912; Kudo & Masamune in Ann. Rep. Taihoku Bot. Gard. 2: 117. 1932; Sasaki, List Pl. Formos. 208. 1928, Cat. Govern. Herb. (Formos.) 241. 1930; Makino & Nemoto, Fl. Jap. ed. 2. 292. 1932; Kanehira, Formos. Trees rev. ed. 245. f. 188. 1936; non Hook. & Arn.

Frutex 2–3 m altus; ramulis plus minusve crassis, novellis laxe pilosis; foliis coriaceis, glabris, ovatis vel ovato-oblongis, 6–9 cm longis, 4–5 cm latis, apice breviter acutis, acuminatis, vel obtusis, basi subobtusis vel acutis, margine remote pauci-dentatis, raro subintegris, dentibus utrinsecus ad 10, interdum ad apicem 2–3, triangularibus, acutis, ad 4–5 mm longis et 7–8 mm latis, costa supra impressa subtus valde elevata, venis secundariis utrinsecus 5–7, arcuato-ascen-

dentibus; petiolis circiter 1 cm longis; inflorescentiis axillaribus vel terminalibus, racemosis, 3–5 cm longis, semper pubescentibus; pedicellis 2–4 mm longis patentibus; bracteis linearibus; calycis tubo infundibulari, 2 mm diametro, limbo 5-lobato, lobis triangularibus, 1.5 mm longis, extus pilosis; petalis 5, albidis, lanceolatis, circiter 2.5 mm longis et 1 mm latis, ad apicem costatis, intus glabris, extus pilosis; staminibus 5, quam petalis plus minusve longioribus, inferne pubescentibus; ovario urceolato, pubescente; fructibus urceolatis, 5–6 mm longis, basim 2 mm crassis, leviter pubescentibus, sepalis persistentibus coronatis, vel 2-carpellis dehiscentibus.

Formosa, in thickets, northern part of the island.

FORMOSA: Nanwo, prov. Kwareenko, *E. H. Wilson 11123* (US); Taihoku, *E. H. Wilson 9908* (US); Sozan, Taihoku-syu, *T. Kawakami*, Oct. 1912 (NTU); Sizangan, Taihoku-syu, *K. Mori*, Oct. 11, 1931 (NTU, type); Herinbi, Taihoku-syu, *E. H. Wilson 10259* (US); Tamsui, *R. Oldham 108* (US); Keelung, *T. Tanaka 346* (US).

*Itea formosana* differs from *I. chinensis*, of the mainland, in the much more coriaceous leaves, often with a few large broad teeth. In the serration it somewhat resembles *I. ilicifolia* Oliver, of western China, but the teeth are not so sharp and fine as in the latter species. The inflorescences are generally shorter and the flowers and fruits are smaller than those of *I. chinensis*.

***Pilostegia viburnoides* Hook. & Thoms. in Journ. Linn. Soc. 2: 76. pl. 2. 1875.**

*Pilostegia viburnoides* Hook. & Thoms. var. *parviflora* Oliver ex Maxim. in Mém. Acad. Sci. St. Pétersb. VII. 10 (16): 18. 1867.

*Schizophragma viburnoides* Stapf. in Bot. Mag. 155: pl. 9262. 1931.

*Pilostegia urceolata* Hay. Icon. Pl. Formos. 3: 105. 1913. *Syn. nov.*

Southern Japan, Liukiu Islands. In Formosa in central mountains at 1,200–2,500 meters.

FORMOSA: Arisan, *E. H. Wilson 9660* (US); Funkiko, prov. Kagi, *E. H. Wilson 10827* (US); Mt. Taiheisan, *H. H. Bartlett 6054* (US), *S. Suzuki 714* (NTU).

Only one species of *Pilostegia* is present in Formosa and this proves to be the same as that of southern Japan and the Liukiu Islands.

ENTOMOLOGY.—*New species of Sarcophagini (Diptera: Sarcophagidae).*<sup>1</sup>

SELWYN S. ROBACK, University of Illinois. (Communicated by C. W. Sabrosky.)

The following descriptions of new species are based on material from several collections examined in the course of phylogenetic studies on the Sarcophaginae. The disposition of the types is indicated after each species description.

***Sarcophaga hollandia*, n. sp.**

Fig. 1

Close to *Sarcophaga antilope* Böttcher and *S. piva* Roback but differs from these in the lack of the golden pollen on the body. Also related to *Sarcophaga beta* Johnston and Teigs, but differs in details of genital structure. The anterior lateral clasper is bifurcate in all three.

*Male*.—Parafrontals and parafacials gray with some golden pollen, both setulose; frontal rows divergent below in last three bristles; facilia setulose three-quarters distance from oral vibrissae to apex of second antennal segment; buccae with only golden hair; antennae and palpi black; outer verticals not distinct; three postocular rows.

Thorax gray-pollinose, longitudinally striped; anterior acrosticals indistinct; prescutellars well developed; four posterior dorsocentrals; three lateroscutellar pairs; one discoscutellar pair; one apioscutellar pair; propleuron setulose.

Abdomen gray; first two segments reddish laterally; with only lateral marginals; third reddish, with median marginals in addition to laterals; fourth reddish, with marginal row of twelve bristles; sternite of third segment with apical brush of setae.

Wings with small costal spine; first vein bare, third setulose; hind tibiae villous; genital segments dark; genitalia shown in Fig. 1, A-D; part of fifth sternite missing as shown in Fig. 1, C.

*Holotype*.—Male, Hollandia, Netherlands New Guinea, rain forest 250 feet, May 1945 (H. Hoogstraal). In collection of Chicago Natural History Museum.

***Sarcophaga piva*, n. sp.**

Fig. 2

Most closely related to *Sarcophaga antilope*

<sup>1</sup>This paper is a joint contribution from the Department of Entomology, University of Illinois, and the Section of Faunistic Surveys and Insect Identification, Illinois Natural History Survey.

Böttcher, *S. alpha* Johnston and Teigs, and *S. hollandia* Roback. Differs from the first two in details of the genitalia and from the latter in possessing golden pollen on the body. The anterior lateral clasper is bifurcate in all three.

*Male*.—Parafrontals and parafacials golden-pollinose; both haired; frontal rows divergent below in last four bristles; facilia setulose a little over three-fifths distance from oral vibrissae to apex of second antennal segment; buccae with mostly black hair; some golden hair anterior to metacephalic suture; antennae and palpi black; outer verticals not distinguishable; three postocular rows.

Thorax golden-pollinose; three longitudinal brown stripes, two faint ones between these; six pair anterior acrosticals; prescutellars well developed; four or five posterior dorsocentrals; the fifth if present, weak; lateroscutellars, three pair; discoscutellars, one pair; apioscutellars, one pair; propleuron setulose.

Abdomen golden-pollinose; first two segments with lateral marginals only; third with median marginals in addition to the laterals; fourth with a complete marginal row.

Wings with weak costal spine; first vein bare third vein setulose; hind tibiae villous; genital segments black; genitalia shown in Fig. 2, A-E.

*Female*.—Outer verticals and proclinate fronto-orbitals distinct; more golden hair on buccae than in male; posterior dorsocentrals six; four small anterior bristles and two large bristles before scutellum; scutellum without apicals; propleuron bare; genitalia brownish black.

*Holotype*.—Male, Piva River, Bougainville, Solomon Islands, June 25, 1944 (B. D. Valentine). In collection of Illinois Natural History Survey.

*Allotype*.—Female, same data as for holotype.

***Sarcophaga lorena*, n. sp.**

Fig. 3

Closely related to *Sarcophaga setigera* Aldrich from which it differs in the shape of the distal segment of the aedeagus and the lack of median marginals on the second abdominal segment.

*Male*.—Parafrontals and parafacials gray; moderately setulose; frontal rows divergent below in last three bristles; facilia setulose three-fourths distance from oral vibrissae to apex of

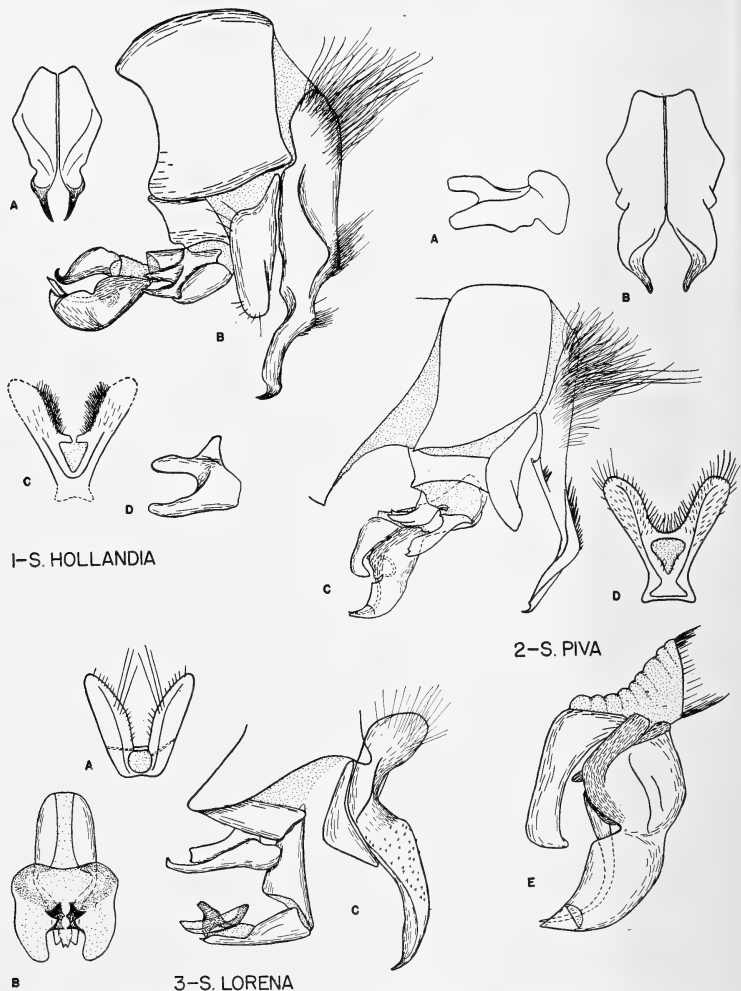
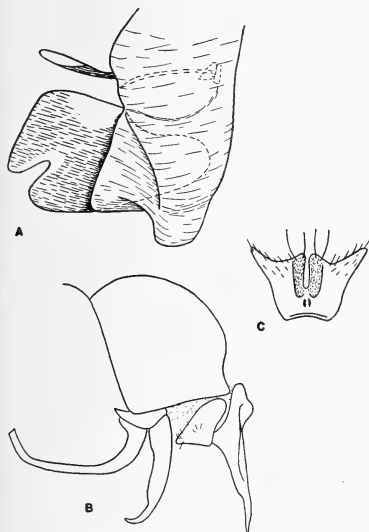
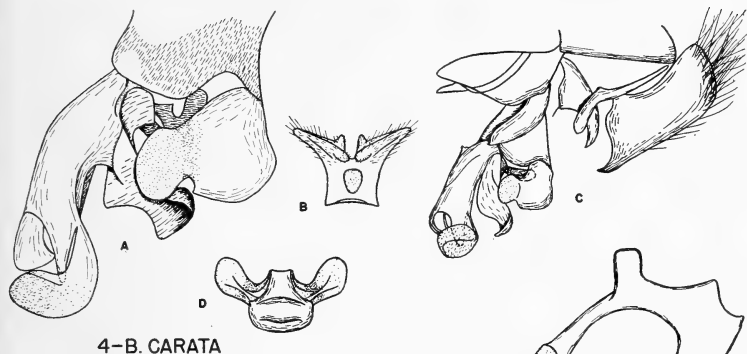
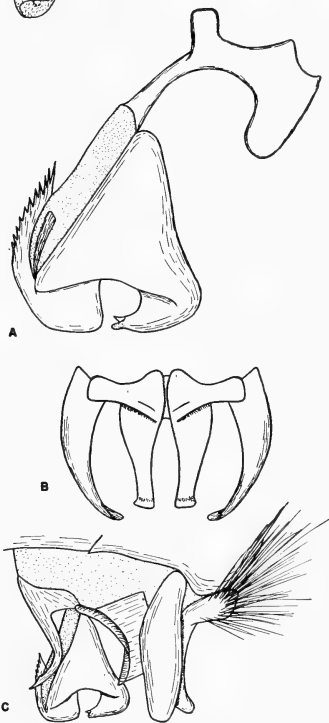

FIG. 1.—*Sarcophaga hollandia*, n. sp.: A, Anal forceps, caudal view; B, genitalia, lateral view; C, fifth sternite; D, left lateral clasper, ventral view. FIG. 2.—*Sarcophaga piva*, n. sp.: A, Left lateral clasper, ventral view; B, anal forceps, caudal view; C, genitalia, lateral view; D, fifth sternite; E, phallus, lateral view. FIG. 3.—*Sarcophaga lorena*, n. sp.: A, Fifth sternite; B, phallus, anterior view; C, genitalia, lateral view.



5-R. TANCITURO



6-Z. CANTENEA

FIG. 4.—*Boettcheria carata*, n. sp.: A, Phallus, lateral view; B, fifth sternite; C, genitalia, lateral view; D, juxta, caudal view. FIG. 5.—*Ravinia tancituro*, n. sp.: A, Phallus, lateral view; B, accessory genital structures, lateral view; C, fifth sternite. FIG. 6.—*Zygastropyga cantenea*, n. sp.: A, Aedeagus, lateral view; B, anal forceps and anal plates, caudal view; C, genitalia, lateral view.

second antennal segment; buccae with black hair only; antennae and palpi brownish; outer verticals not distinct.

Thorax with usual three to five longitudinal stripes; gray-pollinose; three pair anterior acrosticals; prescutellars well developed; three posterior dorsocentrals; lateroscutellars, two or three pair; discoscutellars, one pair; apioscutellars, one pair.

Abdomen gray-pollinose; first two segments with only lateral marginals; third with marginal row of 12 bristles; fourth with marginal row of 16 bristles, reddish apically.

Costal spine present; first wing vein bare; third setulose; hind tibiae bare; genital segments light; genitalia shown in Fig. 3, A-C; fifth sternite cut as shown in Fig. 3, A.

*Holotype*.—Male, Riverhead, Long Island, N. Y., June 30, 1921. In the collection of Cornell University.

*Boettcheria carata*, n. sp.

Fig. 4

Closely allied to *Boettcheria litorosa* (Reinhard) and *B. praevolans* (Wulp). Differs from both in possessing outer verticals and lateral processes on the juxta.

*Male*.—Parafrontals and parafacials setulose; frontal rows sharply divergent below in last five bristles; facialia setulose one-half distance from oral vibrissae to apex of second antennal segment; buccae with only black hair; antennae and palpi brownish; outer verticals present; three post-ocular rows.

Thorax gray-pollinose, striped longitudinally; two or three pair anterior acrosticals; prescutellars very weak; three posterior dorsocentrals; lateroscutellars, three pair; discoscutellars, one pair; apioscutellars, one weak pair.

First two abdominal segments with only lateral marginals; third with a pair of median marginals in addition to laterals; fourth with a marginal row of 30 bristles; slightly red apically.

Costal spine weak; first vein bare; third vein setulose; hind tibiae villous; genital segments reddish; genitalia shown in Fig. 4, A-D.

*Holotype*.—Male, Monterey County, Calif., July 31, 1896. In collection of Chicago Natural History Museum.

*Paratype*.—Male, Custer, S. Dak. In collection of Illinois Natural History Survey.

*Ravinia tancituro*, n. sp.

Fig. 5

Most closely related to *Ravinia planifrons*

(Aldrich) from which it differs in having three instead of four posterior dorsocentrals and in details of the phallus.

*Male*.—Parafrontals and parafacials slightly golden; lightly haired; frontal rows barely divergent below in last bristle; buccae with mostly black hair; antennae and palpi black; outer verticals absent; three postocular rows.

Thorax gray-pollinose with usual three to five longitudinal stripes; one pair anterior acrosticals; prescutellars very weak; three posterior dorsocentrals; lateroscutellars, two pair; discoscutellars, one pair; no apioscutellars.

Abdomen gray-pollinose; first and second segments with only lateral marginals; third with a pair of median marginals in addition to the laterals; fourth with a marginal row of about twelve bristles.

Costal spine lacking; first vein bare; third vein setulose; epaulet yellow; hind tibiae bare; first hypopygial segment dark, second yellowish; genitalia shown in Fig. 5, A-C.

*Holotype*.—Male, Mount Tancituro, sweeping in meadow, 780 feet, Michoacán, Mexico. Fourth Hoogstraal Mexican Biological Expedition, 1941 (H. Hoogstraal). In collection of Chicago Natural History Museum.

*Zygastropyga cantenea*, n. sp.

Fig. 6

Close to *Zygastropyga aurea* Townsend and *Sarcophaga villipes* (Wulp). Differs from former in the greater divergence of the frontal row and from the latter in having the first vein bare. Details of phallus differ from both above species. Also near *Sabinata arizonica* Parker but differs in possessing strong outer verticals and a slight beard on the anterior tibiae.

*Male*.—Parafrontals and parafacials gray with slight brownish cast; both setulose; frontal rows divergent below in last four bristles; facialia setulose to the base of arista; buccae with only black hair; antennae and palpi brown; outer verticals well developed.

Thorax gray-pollinose; longitudinally striped; three pair anterior acrosticals; prescutellars large; four posterior dorsocentrals; lateroscutellars, three pair; discoscutellars, one pair; apioscutellars, one fine pair; propleuron bare.

Abdomen gray-pollinose; first two segments with lateral marginals only; third and fourth abdominal segments missing on holotype.

Costal spine lacking; first vein bare, third vein



setulose; hind tibiae villous; genital segments red; genitalia shown in Fig. 6, A-C.

*Holotype*.—Male, Huachuca Mountains, Cochise County, Ariz., July 21, 1930 (Leonora K. Gloyd). In collection of the University of Michigan.

## LITERATURE

ALDRICH, J. M. *Sarcophaga and allies in North America*: 301 pp., illus. 1916.  
 JOHNSTON, T. H., and HARDY, G. H. *A revision of the Australian Diptera belonging to the genus Sarcophaga*. Proc. Linn. Soc. New South Wales **48**: 94-129, illus. 1923.

LOPES, H. S. *Sobre os géneros Boettcheria Parker 1914 e Boettcherimima, n. gen.* Mem. Inst. Oswaldo Cruz **48**: 687-710, illus. 1950.

PARKER, R. R. *North American Sarcophagidae: A new genus and several new species from the southwest United States*. Bull. Brooklyn Ent. Soc. **16**: 112-115, illus. 1921.

REINHARD, H. J. *New North American muscoid Diptera*. Journ. Kansas Ent. Soc. **20** (3): 95-116, illus. 1947.

SENIOR-WHITE, R., AUBERTIN, D., and SMART, J. *The fauna of British India, including the remainder of the Oriental Region. Diptera 6: Family Calliphoridae*: 288 pp., illus. London, 1940.

ENTOMOLOGY.—*A new genus of Bruchidae affecting Hibiscus in Argentina (Bruchinae: Acanthoscelidini)*. J. C. BRIDWELL, Lignum, Va. (Communicated by Waldo L. Schmitt.)

On March 16, 1940, P. B. Denton, an oiler on a tanker then in the harbor of Buenos Aires, collected 10 adult bruchids on flowers along the River Plate which he subsequently brought to the late Herbert Spencer Barber in the United States National Museum, where they are now preserved. These 10 examples, no two of them alike in coloration, were so peculiar that soon after they reached me in January 1942 I wrote a description of the new genus *Bonaereus*, here presented practically unchanged except for the identification of the species which has received seven specific or varietal names, all proposed by Maurice Pic.

The clue enabling me to name the bruchid and its host plant was found in Juan M. Bosq's highly esteemed "Segunda Lista de Coleópteros de la República Argentina Dañinos a la Agricultura," reprinted in 1943 from the "Ingeniería Agronómica Buenos Aires 1942" **4**: Nos. 18-22. In this reprint (p. 45) under no. 419 is the note:

"*Bruchus inornatipennis* Pic  
 Buenos Aires, Santa Fe, Corrientes. E[ntre] Rios.  
 Ataca semillas de "rosa del Rio" (*Hibiscus cisplatinus* St. Hill.) en la misma planta. Es una especie variable."

Mr. Denton's flowers along the River Plate were thus identified as a plant much like our *Hibiscus militaris*, *moscheutos*, *coccineus*, and *lasiocarpus* in swamps and on river banks which support *Althaeus hibisci*

(Olivier) (see Bridwell, 1946, *The genera of beetles of the family Bruchidae in America north of Mexico*, Journ. Washington Acad. Sci. **36**: 52-57).

The bibliography of Pic's plurinominate species had already been worked out thus:

*Bruchus inlineatus* Pic, 1930, *Melanges* **55**: 12: de l'Argentine. Also var. *testaceicollis* and var. *Deyrollei* on the same page.

*Bruchus inornatipennis* Pic, 1938, *Rev. Soc. Ent. Argentina* **10**: 20: Chaco argentino (Viana), with var. *obscurimembris*: Buenos Aires. On page 78 *inornatipennis* is referred to *inlineatus* as a variety, and on the same page *postreductus* and *latestaceus* were described as varieties of *inlineatus*.<sup>1</sup>

Would that we could forget six of these names, for they represent the descriptions of individual specimens. After examining the Denton series in 1942, I wrote in my notes, "One of the 10 examples is practically entirely reddish testaceous, with apical joints of maxillary palpi, antennal club and claw joints of tarsi somewhat infuscate; another is almost entirely black with the basal five joints of antennae more or less reddish testaceous. The remaining specimens represent intermediates between these extremes,

<sup>1</sup> In 1946 Blackwelder (*Checklist of the coleopterous insects of Mexico, Central America, the West Indies, and South America*, U. S. Nat. Mus. Bull. **185**, pt. 4: 759) listed *inlineatus* and two varieties in *Acanthoscelides*, also separately listed *inornatipennis* and one variety in the same genus, overlooking Pic's merger of the species and the descriptions of two additional varieties on page 78.

some black with pale legs, others with the legs particolored and with the elytra partly red and partly black. In most of them the basal five joints of antennae and joint 11 are pale, while the club is dark above and pale beneath. They are all clothed throughout with thin fine pubescence but little obscuring the surface sculpture."

The combined generic and specific description of the genus *Bonaërius* and its genotype, *Bruchus inlineatus* Pic, follows:

***Bonaërius inlineatus* (Pic), 1930**

Antennal joints 1-5 narrow, 6 small, twice as wide as 5; joints 7-10 transverse, cyathiform, forming with the expanded-ovate joint 11 a broad paddle-shaped club. Head short, frontal carina short, front about twice as broad as inner lobe of eye. Eye emarginate for one-half its length, convex, strongly projecting, temples narrow, abruptly declivous.

Pronotum flat and even above, resembling that of *Bruchus loti* Paykull in shape. Flanks separated from dorsum by a nearly straight marginal carina ending above the coxa remote from the front margin, the flanks not closed in front.

Intercoxal process of prosternum short, metasternum with a deep median longitudinal sulcus.

Scutellum quadrate, emarginately bidentate.

Elytra broader than pronotum, flattened

above, subquadrate, without basal tubercles or elevations. Striae 2-6 and 10 reaching base; striae 5 and 6 abbreviate at apex. Striae strongly impressed and punctured, intervals flat.

Front and middle femora a little more than usually incrassate. Hind femur slender, about as wide as its coxa and narrower than the first sternite behind the coxa, a little flattened beneath, armed near apex within with a single blunt tooth, not reaching apex of abdomen.

Hind tibia slender, not longitudinally carinate beneath or on outer face; armed at apex beneath with two similar symmetrically disposed blunt teeth and above with three subdorsal apical teeth. Basitarsus gently arched, not apically produced beneath, without longitudinal carinae.

Pygidium convex, about as broad as long, oblique; apex of pygidium rounded and bent down, impressed on either side, a prominent little mound in the middle between the two poorly defined impressions.

While the general form resembles *Althaeus hibisci* (Olivier), 1795, *Abutiloneus idoneus* Bridwell, 1946, *Acanthoscelides aequalis* (Sharp), 1885, and other species of *Acanthoscelidini* known to affect seeds of Malvaceae, this resemblance is believed to result from their developing within rounded seeds rather than from any particular affinity among them. The peculiar pygidium distinguishes this genus from any other bruchid known to me.

**HERPETOLOGY.**—*Two Brazilian frogs:* *Hyla wernerii*, n. nom., and *Hyla similis*, n. sp. DORIS M. COCHRAN, United States National Museum.

In 1874, Meyer proposed the name *Hyperolius pygmaeus* for a frog from Jobi Island in Dutch New Guinea (Monatsb. Akad. Wiss. Berlin, 1874: 139). Loveridge (Bull. Mus. Comp. Zool. 101 (2): 397. 1948) lists this species as *Hyla pygmaea* (Meyer). It appears, therefore, that the name *Hyla pygmaea* proposed by Werner in 1894 for a frog from Santa Catharina, Brazil, should be renamed. I propose the following name for the Brazilian frog:

***Hyla wernerii*, n. nom.**

*Hyla pygmaea* (not of Meyer) Werner, Zool. Anz. 7: 411. 1894 (type locality, Blumenau, Santa Catharina); Nieden, Das Tierreich, Anura 1: 289. 1923.

*Hyla pygmaea* Miranda-Ribeiro, Arch. Mus. Nac. Rio de Janeiro 27: 83. 1923; Mello-Leitão, Zoo-geografia do Brasil: 341. 1937.

A gregarious little frog that quacks like a duck occurs in considerable numbers in the Federal District and within the city limits of Rio de Janeiro. So far no name already proposed seems to apply to this species. It is one of the *rubra* group, quite easily recognized as one of that group because of its very thick tibia and the yellow and brown reticulations on the posterior femur. But like all the group, this form also varies individually to a very considerable degree. It may intergrade with *hayii* in the lower mountain regions, and with *fuscovaria* in the uplands of southern Minas Gerais. Only further collecting and study can limit its precise range.

***Hyla similis*, n. sp.**

*Diagnosis.*—Resembles *H. fuscovaria* A. Lutz in shape and structure of head and body and in a

tendency toward a grouping of dark elongate spots dorsolaterally. Differs in its significantly lower average length of head, femur, tibia, and foot, in the absence of clear-cut dorsolateral stripes, in the usually more finely spotted femur and tibia, and in its smaller size (maximum length 37 mm).

*Description of the type.*—An adult male, U.S. N.M. no. 97317, from Manguinhos near the city of Rio de Janeiro collected on February 25, 1935, by Joaquim Venancio. Vomerine teeth in two heavy, short, transverse groups almost continuous medially, between the posterior halves of the choanae; tongue about three-fifths as wide as mouth opening, roundly elliptical except for a deep notch on its free posterior margin; snout rather short, rounded when viewed from above and in profile, the upper jaw extending considerably beyond the lower; nostrils superolateral, greatly projecting, almost at the extreme tip of snout, separated from each other by an interval equal to two-thirds their distance from eye. Canthus rostralis rounded; loreal region slightly concave and very oblique. Eye large, very prominent, its diameter equal to its distance from nostril and to five-sixths the length of snout; interorbital diameter about  $1\frac{1}{4}$  times the width of upper eyelid, greater than distance between nostrils. Tympanum very distinct, about two-thirds the width of eye, separated from eye by a very narrow interval equal to about one-eighth its own diameter. Fingers with a slight trace of a basal web, fourth very slightly longer than second but not reaching the base of third, which covers one-fourth the tympanic area; no rudiment of a pollex visible; toes one-half webbed, fifth slightly longer than third, disk of fourth toe covering about one-fourth the tympanic area; a distinct oval inner and a small, wartlike outer metatarsal tubercle; a faint glandular ridge along inside of tarsus and a still weaker outer tarsal ridge; no dermal appendage on heel. Body moderately heavy in build, in postaxillary region narrower than greatest width of head. When hind leg is adpressed, heel reaches to anterior border of eye; when limbs are laid along the body, knee and elbow are separated by a considerable interval; when hind legs are bent at right angles to the body, heels considerably overlap. Skin of upper parts with numerous elongate glandules and small tubercles, especially prominent on the center of the back; a narrow glandular ridge encircling upper part of tympanum and ending just behind it above the

shoulder; skin of throat and chest with minute scattered pustules, that of belly coarsely granular on the breast, finely granular posteriorly and on the lower surface of femur; a slight skin fold across the chest and another much more prominent preceding it across the throat. A series of lateral folds on each side of the throat marking the presence of lateral gular sacs in the male.

*Dimensions.*—Head and body, 35 mm; head length, 11.5 mm; diameter of eye, 4 mm; width of head, 11 mm; femur, 15 mm; tibia, 16.5 mm; hind limb, 48 mm; forelimb, 19 mm; foot, 14 mm; hand, 9 mm.

*Color in alcohol.*—Dorsal ground color ecru-drab, with an indistinct light sepia triangle between the eyes; a dorsolateral longitudinal series of very irregular sepia spots sometimes anastomosing across the back, their outer margin dark and fairly straight, delineating a dorsolateral stripe of the pale ground color, this light stripe edged below with an indefinite dark stripe, which begins behind the tympanum and breaks up on the sides into a fine reticulation of dark on a light ground, continued and becoming coarser toward the groin; a faint dark line along canthus rostralis; loreal region and upper lip marbled slightly with drab; upper surface of femur with fine sepia reticulations fading out on the anterior surface, becoming darker and coarser on the posterior surface and enclosing irregular pale cinnamon areas; upper surface of tibia with three large diagonal spots; outer tarsus and upper arm indistinctly marbled with drab; ventral surface immaculate buff.

*Color in life.*—Some color notes on living specimens from Manguinhos were made on January 18, 1935. U.S.N.M. no. 97374: Malachite to sage green above, immaculate. Posterior femur chrome-yellow with brown reticulations. Throat citron-yellow; belly sulphur-yellow in the center, chrome-yellow toward the sides, immaculate. U.S.N.M. no. 97376: Dorsum clay color in center, with a drab dorsolateral stripe. Groin and ventral surface olive-buff, the sides with sepia spots. Fore and hind legs ochraceous, barred with raw umber. U.S.N.M. no. 97375: Dorsum light olive-gray, with coarse mouse-gray blotches edged with black. Upper and posterior parts of femur orange-ochraceous, mottled with dark sepia. Chin, chest, and lower parts of limbs ecru-drab; belly pale blue.

*Variations.*—Within the usual limits there is the same amount of confusing variation in this

species that is met with in the other members of the *rubra* group. The snout is usually rounded, but in about one-third of the examples it is slightly pointed. The tympanum, always distinct, may range from one-half to two-thirds the diameter of the eye in width. The interorbital diameter is often  $1\frac{1}{2}$  times the width of the upper eyelid, but in a few instances scarcely exceeds the eyelid in width. The distance from the posterior border of the tympanum to the tip of the snout varies between 31 and 36 percent of the total length of head and body, while the tibia is from 43 to 54 percent of this length. The adpressed heel may reach occasionally only to the posterior corner of the eye, most often to the center or anterior border of the eye, and rarely as far as the nostril. The disks of the fingers may be large, moderate or rather small, and as the tympanum itself varies considerably in size, the fourth finger disk may cover as little as one-fourth of its area to as much as two-thirds. The skin of the back is smooth in perhaps one-fourth of the specimens (this may depend on preservation to some extent), faintly granular all over in some, granular only on the posterior part in others.

The pattern seems as varied as do the physical dimensions. Usually there is a more or less distinct dark area between the eyes, but no other markings are at all constant. Some individuals are pale drab, with remnants of longitudinal dark stripes as in *rubra* appearing in this species as two rather irregular dark stripes enclosing a light area on each side of the back. In other specimens the upper one of the two dark stripes shortens and becomes crescentic; in many cases its inner edge approaches its fellow until they nearly fuse across the back, and in some cases they actually do become fused, with a few scattered light spots on them which may indicate their usual limits. Sometimes there is an irregular network of coarse dark spots down the back; sometimes an inverted V or its separated elements may appear on the sacral region. The upper part of the femur is usually irregularly spotted or reticulated; in only a few instances do these spots suggest the regular dark cross bars characterizing some other members of this group. Quite often the posterior surface of the femur reveals a rather large, very irregular, elongate light spot surrounded and set off by narrow dark reticulations. In other cases the posterior femur is finely marbled with small light and dark spots in about equal proportions. The upper surface of the tibia often has three irregular oval

spots placed diagonally across it. Any of these dark spots may lighten, leaving only a narrow dark outline which suggests a parallelogram or an irregular circle. Numerous small dark dots scattered over the upper surfaces still further obscure the pattern. The sides sometimes show linear rows of dark dots more or less fused into a network, or often a scattering of fine dots with no particular arrangement. The groin quite often has a very pale (yellowish in life) area, confined sometimes to an elongate irregular spot encircled by darker, heavier reticulations. The ventral surface appears to be immaculate in the specimens at hand. A good many individuals show a dark brown stripe along the canthus, with considerable spotting on the upper lip; other specimens have a much lighter canthal stripe and the labial spots are reduced to a light marbling. Sometimes the canthal stripe is continued over the tympanum as a narrow dark line, widening behind the ear and often ending in front of the forearm, but also sometimes carried part way down the side as an irregular dark stripe.

*Remarks.*—It is perhaps rash to give a new name to another of the *rubra* group, the most variable of any in Brazil, but no formerly proposed name seems to be applicable to the form coming from within the Federal District. *H. x-signata* of Spix from Bahia is apparently nearest to *similis*, after *fuscovaria*, but fresh Bahian material is needed before an exact comparison can be made.

This species has the peculiar habit of "swarming," as hundreds appeared at one time on a tree outside the laboratory at the Instituto Oswaldo Cruz. The voice of the adult is a high-pitched *crack, crack, crack*, sounding somewhat like that of a duck. Breeding takes place in March and April. The tadpoles metamorphose very rapidly, taking only 20 to 30 days to change into frogs, but they are rather delicate, as they die from the effects of too much sun if the water in which they live is not deep enough.

While this species is exceedingly plentiful at Manguinhos, it is not known from the southern part of the state of Rio de Janeiro. In fact, only two other examples at all resembling this form are known outside of the Manguinhos material. One of these is from Bom Sucesso, a few minutes' ride by automobile from Manguinhos, while the other, no. 96213, not in good condition but seeming to belong to the present species, is from Amorim near the city of Rio de Janeiro.

## MATHEMATICAL ANALYSIS

	Head length	Head width	Femur	Tibia	Foot	Hand
N	49	49	49	49	49	49
M	33.7	31.9	42.0	48.0	39.0	26.2
$\sigma$	1.2	1.2	1.3	2.0	2.0	1.4
$\nu$	3.56	3.76	3.10	4.17	5.13	5.36
$\sigma_m$	0.01	0.54	0.44	0.50	0.73	0.77
Range	31.1— 36.0	29.4— 35.1	37.9— 47.1	43.5— 54.2	34.8— 47.5	23.9— 30.0

List of specimens.—Rio de Janeiro (state): U.S.N.M. no. 97317, the type of *Hyla similis*, and paratypes U.S.N.M. nos. 97312–6, 97318–52,

97374–6, from Manguinhos, all collected between January 18 and May 20, 1935, mostly by J. Venancio; U.S.N.M. nos. 96144–6 from Manguinhos collected in January 1922; U.S.N.M. no. 96203, an adult male from Bom Sucesso near the city of Rio de Janeiro, collected on October 25, 1928, and received from Dr. A. Lutz; U.S.N.M. no. 96213 from Amorim near the city of Rio de Janeiro collected in January 1926; U.S.N.M. nos. 81119–21 from Rio de Janeiro, collected in 1930 and received from Dr. A. Lutz.

HELMINTHOLOGY.—*Hymenolepis johnsoni*, n. sp., a cestode from the vole *Microtus pennsylvanicus drummondii*. EVERETT L. SCHILLER, Arctic Health Research Center, Anchorage, Alaska. (Communicated by Harald A. Rehder.)

In connection with a separate work concerning morphological variation, the writer had occasion to study a number of hymenolepidid cestodes obtained from the autopsy of some preserved microtine rodents in the collection of the U. S. National Museum. Two of these cestodes, taken from a vole, *Microtus pennsylvanicus drummondii* (Audubon and Bachman), collected at Fort Rae, District of Mackenzie, Canada, represent a species of the genus *Hymenolepis* Weinland, 1858, which appears to be unknown in the parasitological literature and therefore is herein described as new.

The voles from which this material was taken were included among a large series of preserved rodents made available to Dr. Robert Rausch, of this laboratory, in conjunction with a survey of the helminth parasites of Nearctic microtine rodents. All hymenolepidid cestodes were turned over to the writer for study. This opportunity is taken to express to Dr. David H. Johnson, associate curator, division of mammals, U. S. National Museum, appreciation of his generous cooperation, which has made these studies possible.

*Hymenolepis johnsoni*, n. sp.

Figs. 1–3

*Diagnosis*.—Length of strobila 30–40 mm; maximum width 1.4 mm, attained at posterior end. Scolex diameter 150–180 $\mu$ . Suckers, unarmed, 64 by 80 $\mu$ . Evaginated rostellum 160 $\mu$  long by 48 $\mu$  wide at apex, which supports single row of 10 hooks 15 $\mu$  in length. Strobila 108 $\mu$  wide immediately posterior to

base of scolex. Genital pores unilateral and dextral. Genital ducts pass dorsal to excretory canals. Cirrus sac muscular, averages 112 $\mu$  in length by 43 $\mu$  in diameter in mature proglottids. External seminal vesicle well developed, 115 by 72 $\mu$ . Cirrus armed with minute spines. Testes, three in number, ovoid, 24 by 32 $\mu$ , arranged in form of triangle with one testis poral and two aporal to ovary and vitelline gland. Deeply lobed ovary located in middle of proglottid. Vitelline gland lies ventral and posterior to ovary. Vagina ventral and posterior to cirrus sac. Saccate seminal receptacle prominent in mature proglottids, attains maximum size of 168 by 104 $\mu$ . Uterus extends as slender irregular tube transversely across anterior part of proglottid, passing dorsal to excretory canals and reaching beyond them. Completely developed eggs not observed. Ventral longitudinal excretory canals measure 93 $\mu$  in diameter; dorsal canals, 11 $\mu$  in diameter.

*Host*.—*Microtus pennsylvanicus drummondii* (Audubon and Bachman).

*Locality*.—Fort Rae, District of Mackenzie, Canada.

*Habitat*.—Small intestine.

*Type*.—One slide, no. 37340, containing an entire specimen, has been deposited in the Helminthological Collection of the U. S. National Museum.

## DISCUSSION

Baer (1931) listed 14 armed species of *Hymenolepis* parasitic in rodents and added *H. muris-sylvatici* (Rudolphi, 1819) to this

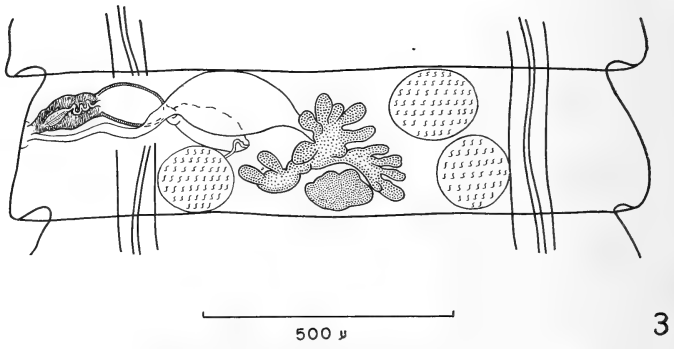
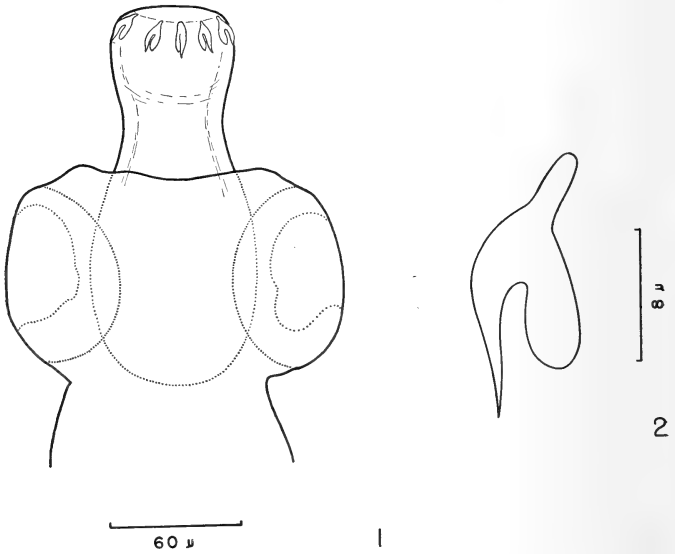

FIGS. 1-3.—Morphological details of *Hymenolepis johnsoni*, n. sp.: 1, Scolex; 2, rostellar hook; 3, late mature proglottid (ventral view).

list. In a further review of the taxonomic status of this group (1932) he reduced the total number to 13. More recently Rider and Macy (1947) described *H. ondatrae* bringing the total again to 14. Of these, only four species have 10 rostellar hooks. These were found to differ from *H. johnsoni* as follows:

*H. evaginata* Barker and Andrews, 1915 (from *Ondatra zibethica* L.), has a strobila of much greater length (200–400 mm), a bilobed ovary, and smaller rostellar hooks (7 $\mu$ ) of a characteristically different shape.

*H. pearsei* Joyeux and Baer, 1930 (from *Hybomys univittatus* Peters), has a larger cirrus sac (520 by 60 $\mu$ ), testes arranged in a straight line, the ovary and vitelline gland poral to midline, and much longer rostellar hooks (60 $\mu$ ) of a different shape.

*H. muris-sylvatici* (Rudolphi, 1819) (from *Apodemus sylvaticus* (L.)) has an aspinose cirrus and larger rostellar hooks (23 $\mu$ ), which differ markedly in shape.

*H. ondatrae* Rider and Macy, 1947 (from *Ondatra zibethica occipitalis* (Elliot)), has a larger cirrus sac (30–35 by 150–220 $\mu$ ), an ovary that is smooth or may tend to be trilobate, and rostellar hooks that vary in number from 8 to 10, are of a much greater length (67–73 $\mu$ ), and have a distinctly different shape.

This cestode is named in honor of Dr. David H. Johnson, whose interest in these studies made possible the examination of valuable host material.

#### REFERENCES

- BAER, J. G. *Sur la position systématique du Taenia muris-sylvatici Rudolphi, 1819.* Bull. Soc. Neuchâtel. Sci. Nat. **55**: 35–39. 1931.
- . *Contribution à la faune helminthologique de Suisse.* Rev. Suisse Zool. **39**: 1–57. 1932.
- RIDER, C. L., and MACY, R. W. *Preliminary survey of the helminth parasites of muskrats in northwestern Oregon, with description of Hymenolepis ondatrae n. sp.* Trans. Amer. Micr. Soc. **66**: 176–181. 1947.

ZOOLOGY.—*Geographical distribution of the species of nemerteans of the Arctic Ocean near Point Barrow, Alaska.*<sup>1</sup> WESLEY R. COE, Scripps Institution of Oceanography. (Communicated by Fenner A. Chace, Jr.)

Nemerteans occur along the borders of all the oceans, from beneath the Polar Seas northwest of Greenland (Coe, 1944) to the ice barrier surrounding the South Pole (Coe, 1950). Moreover most of the same genera, but not the same species, are found in both these extremes of latitude.

The floor of the Arctic Ocean near Point Barrow is evidently well adapted for populations of nemerteans, for Prof. and Mrs. George MacGinitie during their two years at the Arctic Research Laboratory<sup>2</sup> collected more than 300 specimens of these worms. Nemerteans were found at nearly all the dredging stations, from shallow water to depths of about 250 meters 12 to 16 miles from shore. The collections contained 24 recognizable species, among which are 7 species of *Amphiporus*, 4 of *Tubulanus*, 3 of

*Micrura*, 4 of *Tetrastemma*, 2 of *Cerebratulus*, 1 each of *Lineus*, *Emplectonema*, *Nemertopsis*, and *Paranemertes*. As in other collections from Arctic seas, the genus *Amphiporus* has not only the greatest number of species but some of the species have also the largest populations. *A. angulatus* and *A. lactifloreus* are the most abundant species in the Point Barrow area. Ten of the species have not been reported previously from strictly Arctic seas, although three of these have been found in the nearby Bering Sea.

These collections are of particular interest because only three species of nemerteans were formerly known from that portion of the Arctic seas and the others contribute to an understanding of the circumpolar distribution of some of the species. Even at the present time no nemerteans are known from the Polar seas between the Point Barrow area and northwest Greenland on the east and Nova Zembya and Franz Josef Land on the west.

From the Polar seas the populations of

<sup>1</sup>Contribution of the Scripps Institution of Oceanography, new series, no. 557.

<sup>2</sup>Supported by the Office of Naval Research through contracts with the California Institute of Technology and the Johns Hopkins University.

several of the species extend southward along the European, American, and Asiatic coasts. *Cerebratulus marginatus* may be mentioned as a species with an unusually extensive geographical distribution, for the range of this species extends from near King Karl Land, Spitsbergen, and elsewhere in the Arctic to Norway, Great Britain, the Mediterranean and Madeira in the eastern Atlantic and from Greenland to Labrador, Nova Scotia, New England, Cape Cod, and farther southward beneath the offshore current in the western Atlantic. It also extends from the Point Barrow area, Bering Sea, Pacific coast of Alaska and southward to southern California along the American coast, and to Kamchatka and Japan on the Asiatic coast. This does not imply that the populations in the present geological era are continuous through all this vast extent of territory, nor can it be assumed that the species originated in that portion of the globe which is now occupied by the Polar seas. The species presumably exists as isolated, localized, more or less widely separated populations. Moreover it is probable that it is even more widely distributed than is at present known.

Four other species, *Lineus ruber*, *Cerebratulus fuscus*, *Amphiporus lactifloreus*, and *Tetrastemma candidum*, similarly extend southward along the European and American Atlantic coasts, while *Amphiporus angulatus* extends from Greenland as far south as southern New England in the western Atlantic and from Point Barrow to California on the American coast, as well as to Japan on the Asiatic coast, but it has not been found in the eastern Atlantic.

*Amphiporus lactifloreus* occurs on both the European and American Atlantic coasts, as well as in the Arctic, but has not been reported from the Pacific, while *Tubulanus capistratus* is found on both sides of the Pacific, from Point Barrow to California and to Japan, but not in the Atlantic. The Point Barrow area therefore forms an intermediate link for those species formerly known to occur in the Polar seas north of Europe or near the coasts of Greenland, or both, and those on either the American or Asiatic Pacific coasts or both.

Relatively few species of nemerteans are

known to occur in both the Northern and Southern Hemispheres. Of those here reported for the Point Barrow area, *Tubulanus annulatus*, *Lineus ruber*, *Cerebratulus fuscus*, and *Tetrastemma candidum* have been found also on the coast of South Africa and *Emplectonema gracile* on the coast of Chile.

The following list, arranged in systematic order, gives the geographical distribution of each of the species found in the Point Barrow area in so far as at present known. A similar list of the distribution of other species reported for Arctic seas has been published by Coe (1944).

#### Order PALEONEMERTEA

*Tubulanus albocinctus* (Coe), 1904. This is the first record of this species in Arctic seas. It has been dredged previously among red algae at depths of 100 to 200 meters off the coast of southern California. One specimen, about 107 mm in length, was collected at a depth of 65 meters between 4 and 5 miles from shore off Point Barrow.

*Tubulanus annulatus* (Montagu), 1804. This species is widely distributed on the eastern shores of the North Atlantic, from Norway and Great Britain to the Mediterranean; it has also been reported from the South Atlantic, near the Cape of Good Hope. In the Arctic it has been dredged near King Karl Land, off Cape Platen, and in the Karajek Fiord, Greenland, as well as off the northwest coast of Greenland (Coe, 1944). In the Point Barrow area it was found at depths up to 126 meters and up to 7 miles from shore.

*Tubulanus capistratus* (Coe), 1901. This species is closely similar to the preceding but is without the white band on the dorsal surface of the head. It has been found in the intertidal zone and below along the Pacific coast of Alaska and southward to Monterey Bay, Calif., and it is also reported from Japan. In the Point Barrow area it was collected at depths of 3 and 131 meters, from near shore and 12 miles out.

*Tubulanus frenatus* (Coe), 1904. One specimen was found near Point Barrow. Previously recorded only from southern California.

#### Order HETERONEMERTEA

*Lineus ruber* (O. F. Müller), 1771. Circumpolar; coasts of Siberia; Greenland; Norway and Great Britain to the Mediterranean, Madeira and South Africa; Labrador to southern New England;



Alaska to California. In the collections from the Point Barrow area only two specimens were assigned to this species. One of these was found near shore and the other at a depth of 136 meters 8 miles out.

*Micrura alaskensis* Coe, 1901. A common species in the intertidal zone and below along the Pacific coast of Alaska and southward to northern Mexico. Found also in Japan. In the Point Barrow area only four individuals were obtained. One of these was found near shore and the others 4 to 7 miles out, at depths of 50 to 65 meters.

*Micrura impressa* (Stimpson), 1857. Originally described from an individual dredged in Bering Strait. Later reported from Japan (Yamaoka, 1940). One specimen measuring 97 mm in length and 9 mm in width when contracted was found washed ashore at Point Barrow.

*Micrura purpurea* (Dalyell), 1853. Reported in Arctic seas northwest of Greenland, Karajak Fjord and Hinlopen Strait at depths of 45 to 115 meters (Coe, 1944). Common on European coasts from the intertidal zone to depths of 200 meters or more. One specimen was obtained in the Point Barrow area at a depth of 143 meters, 16 miles from shore.

*Cerebratulus barentsi* Bürger, 1895. The minor morphological features which have been thought to separate this species from *C. marginatus* have evidently resulted from different states of contraction of the head. Hence *C. barentsi* is no longer considered to be a valid species.)

*Cerebratulus fuscus* (McIntosh), 1873-4. This is a species with a very wide geographical distribution, for it has been reported not only from the coasts of Greenland and elsewhere in Arctic seas, but also from Norway and Great Britain to the Mediterranean, as well as South Africa and Florida (Coe, 1951). The single specimen collected in the Point Barrow area was dredged at a depth of 41 meters, 3.5 miles from shore.

*Cerebratulus marginatus* Renier, 1804. This species has the wide circumpolar distribution previously mentioned, being found on European coasts as far south as Madeira; on the eastern North American coasts it extends southward to Cape Cod and farther south beneath the offshore current; on the western North American coast southward to southern California and in the western Pacific as far south as Japan. In the Arctic it has been reported from King Karl Land, Bremer Sound, Hinlopen Strait, East Spisbergen, and northwest Greenland. In the Point Barrow

area it was found at depths of 61 to 222 meters, 5 to 12 miles from shore.

#### Order HOPLONEMERTEA

*Emplectonema gracile* (Johnston), 1837. One small specimen about 30 mm long and 1 to 2 mm in diameter after preservation was obtained in the Point Barrow area at a depth of 38 meters. This is one of the most widely distributed of all species of nemerteans, being abundant in the intertidal zone and below, on the northern coasts of Europe and southward to Madeira; on the coasts of Alaska to California and northern Mexico, and it has been reported also from Chile, as well as from Kamchatka and Japan. It has not been recorded previously from Arctic areas.

*Paranemertes peregrina* Coe, 1901. In many localities this is the most abundant nemertean in the intertidal zone along the Pacific coast of Alaska and southward to California. It has also been reported from the Aleutian Islands, Kamchatka and Japan. Only a single representative of this species was found in the Point Barrow area.

*Nemertopsis gracilis* Coe, 1904. Previously reported from Pugent Sound to northern Mexico. Only one specimen was dredged in the Point Barrow area.

*Amphiporus angulatus* (Fabricius), 1774. The collections indicate that this is the most abundant nemertean in the Point Barrow region. Because of the relatively large size of many individuals and their conspicuous coloration, it is unlikely that they would be overlooked by the collector. This species was found at 9 stations, where the depths were between 12 and 226 meters. The distance from shore varied from 2.75 to 16 miles. This species is widely distributed in Arctic seas, having been reported from near Greenland, Baffin Bay, Davis Strait, Labrador, Nova Scotia, southward to Cape Cod and further south beneath the offshore Arctic current. On the Pacific coast of North America it extends through Bering Sea, along the coast of Alaska and south as far as Point Conception, California. On the Asiatic coast it has been found on the shores of Kamchatka and Japan. It was collected by Stimpson (1857) in Bering Strait.

*Amphiporus formidabilis* Griffin, 1898. Previously recorded from Bering Island, Aleutian Islands, coast of Alaska and southward to Monterey Bay, California. Two specimens in the Point Barrow collections were dredged at depths of about 62 and 226 meters, 5 to 12 miles from shore.

*Amphiporus groenlandicus* (Oersted), 1844. This is another species that is widely distributed in Arctic seas, having been reported from both the eastern and western coasts of Greenland, from Hinlopen Strait, Barents Sea, and from the waters off King Karl Land, Jena Island, Franz Josef Land, and Spitzbergen at depths of 4 to 450 meters. The same or a closely similar species, *A. caecus* Verrill, also without ocelli, has been dredged at a depth of about 35 meters off the New England coast (Coe, 1943). *A. groenlandicus* was found in the Point Barrow area at depths of 40 to 247 meters and up to 12 miles from shore.

*Amphiporus imparispinosus* Griffin, 1898. This has been reported previously from the Bering Sea and it is abundant in many localities in the intertidal zone and below, along the coast of Alaska and southward to Ensenada, Mexico. The typical form, which has three pouches of accessory stylets is often associated with the variety *similis*, which has only two. The species was found in the Point Barrow area at depths of 37 to 104 meters and up to 7 miles from shore.

*Amphiporus lactifloreus* (Johnston) 1828. With the exception of *Amphiporus angulatus*, this species appears to be the most abundant nemertean in the Point Barrow area. The species was found at 13 stations, where the depths varied from 12 to 226 meters and at distances up to 12 miles from shore. It is widely distributed along the shores of the Arctic and North Atlantic oceans, extending southward to the Mediterranean Sea and on the American coast as far as Cape Cod. Except in the far north it occurs in the intertidal zone and in some areas to depths of 200 meters.

*Amphiporus macracanthus* Coe, 1905. This species is known only from the Arctic coast of Alaska, where it was collected as early as 1882 near Cape Smyth and at a later date at Wainwright Inlet (Coe, 1905). In the Point Barrow area it was found at depths of 38 to 53 meters and up to 4 miles from shore.

*Amphiporus pacificus* Coe, 1905. Previously dredged at depths of 70 to 180 meters in the Bering Sea and off the coasts of Washington and California. Collected in the Point Barrow area at depths of 9 to 226 meters and up to 12 miles from shore.

*Tetradostemma aberrans* Coe, 1901. Several specimens were dredged at depths of less than 40 meters. Previously known only from the coast of Alaska.

*Tetradostemma bicolor* Coe, 1901. Previously known only from Kodiak Island, Alaska. One individual was dredged at a depth of 50 meters about 3 miles from Point Barrow.

*Tetradostemma candidum* (Müller), 1774. Circumpolar; Greenland; Norway to Madeira; South Africa; Labrador to southern New England and southward to northern Florida; northern coast of the Gulf of Mexico; Alaska to California and northern Mexico. In the Point Barrow area the species was found at depths of 34 to 145 meters and up to 16 miles from shore.

*Tetradostemma coronatum* (Quatrefages), 1846. The collection from the Point Barrow area was accompanied by a colored photograph of an individual of this species that had been dredged at a depth of 50 meters, about 3 miles from shore. Common on European coasts and the Mediterranean. Reported also in Japan (Yamaoka, 1940).

All the specimens in this collection are in the U. S. National Museum.

#### REFERENCES

- BÜRGER, OTTO. *Beiträge zur Anatomie, Systematik und geographische Verbreitung der Nemertinen*. Zeitschr. wiss. Zool. **61**: 16-37. 1895.
- . *Die Nemertinen*. Fauna Arctica **3**: 57-64. 1903.
- COE, W. R. *Nemerteans of the west and northwest coasts of America*. Bull. Mus. Comp. Zool. **47**: 1-319. 1905.
- . *Revision of the nemertean fauna of the Pacific coasts of North, Central and northern South America*. Allan Hancock Pacific Exped. **2**: 247-323. 1940.
- . *Biology of the nemerteans of the Atlantic coast of North America*. Trans. Connecticut Acad. Arts and Sci. **35**: 129-328. 1943.
- . *Nemerteans from the northwest coast of Greenland and other Arctic seas*. Journ. Washington Acad. Sci. **34**: 59-61. 1944.
- . *Nemerteans from Antarctica and the Antarctic Ocean*. Journ. Washington Acad. Sci. **40**: 56-59. 1950.
- . *Geographical distribution of the nemerteans of the northern coast of the Gulf of Mexico as compared with those of the southern coast of Florida, with descriptions of three new species*. Journ. Washington Acad. Sci. **41**: 328-331. 1951.
- PUNNETT, R. C. *Arctic nemerteans*. Proc. Zool. Soc. London 1901: 90-107. 1901.
- USCHAKOW, P. *Beschreibung einiger neuen Nemertinenarten von Barents-Meere, Weissen Meere und Nowaja-Semlja*. Zool. Jahrb. **54**: 407-424. 1928.
- YAMAOKA, TEIICHI. *The fauna of Akkeshi Bay, IX Nemertini*. Journ. Fac. Sci. Hokkaido Imp. Univ. (ser. VI, Zool.) **7**: 205-263. 1940.

## NEW MEMBERS OF THE ACADEMY

There follows a list of persons elected to membership in the Academy, by vote of its Board of Managers, since March 1, 1950, who have since qualified as members in accordance with the bylaws. The bases for election are stated with the names of the new members.

### RESIDENT

*Elected March 20, 1950*

GEORGE S. SWITZER, associate curator of mineralogy and petrology, U. S. National Museum, in recognition of his studies of systematic mineralogy.

*Elected April 17, 1950*

HERBERT LEADERMAN, physicist, rubber section, National Bureau of Standards, in recognition of his work on the physics of high polymers and in particular his contributions to rheology as exemplified by research on the creep and flow of rubbers and fibers.

*Elected May 15, 1950*

J. M. AMBERSON, commander, Medical Corps Reserve, USNR, chief of tropical medicine, Naval Medical School, in recognition of his studies of tropical diseases, especially cholera and schistosomiasis, and for his leadership in field surveys to probe into the epidemiology of these diseases and improved methods for their control.

ROBERT G. BRECKENRIDGE, physicist, National Bureau of Standards, in recognition of his contributions to chemical physics and in particular his work on the electrical properties of solids.

LLOYD A. BURKEY, bacteriologist, Bureau of Dairy Industry, in recognition of his studies on the pectin-fermenting bacteria, his contributions on the bacteriology of Swiss cheese and on cultured milks, and his contributions in bacteriological studies on the detection, diagnosis, and causes of bovine mastitis.

WILLIAM D. FIELD, associate curator of insects, U. S. National Museum, in recognition of his taxonomic and distributional studies of the Lepidoptera, the butterflies and larger moths in particular.

ROBERT TRAUB, major, U. S. Army, chief, department of parasitology, Army Medical Center, in recognition of outstanding contributions to the systematics of fleas and to the epidemiology of scrub typhus.

*Elected October 30, 1950*

B. M. AXILROD, physicist, National Bureau of

Standards, in recognition of his contributions to knowledge of the mechanical properties of plastics and of cohesive forces in crystals of the rare gases.

E. W. CANNON, assistant chief, applied mathematics division, National Bureau of Standards, in recognition of his contributions to the development of high-speed automatic computing machinery, and to the establishment of a strong federal program in applied mathematics.

HAROLD E. CLEAVES, chief, chemical metallurgy section, National Bureau of Standards, in recognition of his contributions in the field of physical metallurgy, particularly in the preparation and determination of the properties of the purest iron ever prepared.

IRVING A. DENISON, chief, underground corrosion section, National Bureau of Standards, in recognition of his contributions to theory of corrosion and corrosion prevention in soils and measurement of the corrosion of metals in soils.

THOMAS G. DIGGES, chief, thermal metallurgy section, National Bureau of Standards, in recognition of his contributions to metallurgy, in particular his studies of machinability, hardenability, and creep.

GEORGE A. ELLINGER, chief, optical metallurgy section, National Bureau of Standards, in recognition of his work in the field of metallurgy, particularly in metallography and corrosion.

EARL K. FISCHER, chief, organic coatings section, National Bureau of Standards, in recognition of his contributions to rheology and colloid chemistry.

ALPHONSE F. FORZIATI, research associate of the American Dental Association at the National Bureau of Standards, in recognition of his contributions to physical chemistry, in particular his studies of the purification and properties of petroleum hydrocarbons.

THOMAS WALLER GEORGE, head, armor materials section, Naval Research Laboratory, in recognition of his studies of the mechanical strength of solids, in particular the relation between strain rate and strength.

WAYNE C. HALL, superintendent, electricity division, Naval Research Laboratory, in recognition of his work on electrostatic charging of aircraft and on thermal conductivity.

HOMER D. HOLLER, general physical scientist, National Bureau of Standards, in recognition of his contributions to the theory of corrosion and his applications of electrical theory to corrosion and corrosion prevention.

DONALD HUBBARD, chemist, glass section, National Bureau of Standards, in recognition of his contributions to physical chemistry and in particular his studies of photographic emulsions and the relation between chemical durability and pH response of glass electrodes.

PETER KING, branch head, chemistry division, Naval Research Laboratory, in recognition of his contributions to chemistry and optics, in particular his studies of low-reflecting coatings.

LUTHER B. LOCKHART, JR., research chemist, Naval Research Laboratory, in recognition of his work on separation of the constituents of petroleum and pilot plant work on extraction of alumina from clay.

HOWARD F. McMURDIE, chief, constitution and microstructure section, National Bureau of Standards, in recognition of his work in applied crystallography and phase studies in inorganic chemistry, especially as regards portland cement, ceramics, and dry cells.

W. T. READ, chemical adviser, general staff, G-4, U. S. Army, in recognition of his contributions to organic chemistry, particularly the chemistry of hydrazines and hydantoins, to education in chemical engineering, and to the history of chemistry.

JOHN A. SANDERSON, superintendent, optics division, Naval Research Laboratory, in recognition of his contributions to optics, particularly his researches in the infrared.

A. L. SHALOWITZ, chief, research, review, and technical information section, U. S. Coast and Geodetic Survey, and special assistant to the director, in recognition of his research work in the field of nautical cartography and in the standardization of practices relating to hydrographic surveying, particularly in the matter of interpretation of charts and surveys for scientific and legal purposes.

JAMES L. THOMAS, chief, resistance measurements section, National Bureau of Standards, in recognition of his contributions to physics and in particular to precise electrical measurements.

LEROY W. TILTON, physicist, optical instruments section, National Bureau of Standards, in recognition of his contributions to physics, particularly in the field of refractometry.

HERBERT C. VACHER, X-ray metallographist, National Bureau of Standards, in recognition of his researches on gases in metals, physical chemistry of steel making, and plastic deformation of metals.

SAMUEL G. WEISSBERG, physicist, organic plas-

tics section, National Bureau of Standards, in recognition of his work on the properties of high polymers in solution and his contributions to our knowledge of the properties of building materials and aircraft finishes.

*Elected November 20, 1950*

B. D. BURKS, entomologist, Bureau of Entomology and Plant Quarantine, in recognition of his contributions to the classification and biology of insects, especially his studies in the taxonomy of parasitic wasps and of mayflies.

FRANK R. CALDWELL, physicist, combustion section, National Bureau of Standards, in recognition of his contributions in the field of combustion, particularly as applied in gas turbines and jet engines.

ANDREW I. DAHL, physicist in charge of gas temperature measurements, National Bureau of Standards, in recognition of the development of thermocouple pyrometers for use in gas turbines and jet engines.

MILDRED A. DOSS, zoologist, zoological division, Bureau of Animal Industry, in recognition of her services to the science of parasitology through the maintenance of the Index Catalogue of Medical and Veterinary Zoology, which provides a working tool of inestimable value to parasitologists the world over.

U. FANO, physicist, National Bureau of Standards, in recognition of his contributions to theoretical nuclear physics, in particular his studies on the penetration of radiation through barriers.

MARION M. FARR, parasitologist, zoological division, Bureau of Animal Industry, in recognition of her work on the Protozoa and protozoan diseases on poultry.

MARSHALL C. GARDNER, biologist, U. S. Fish and Wildlife Service, in recognition of his research in mammalogy, and in particular his researches on the taxonomy of the mammalian genera *Sigmodon* and *Lynx*.

DEFOE C. GINNINGS, chemist in charge of high-temperature calorimetry, National Bureau of Standards, in recognition of his contributions to calorimetry, and in particular of the development of the ice calorimeter and its application to accurate measurements of heat capacities at high temperatures.

FRANK L. HOWARD, acting chief, engine fuels section, National Bureau of Standards, in recognition of his contributions to the synthesis of hydrocarbons of high purity, particularly those of interest in internal combustion engines.

K. C. KATES, parasitologist, zoological division, Bureau of Animal Industry, in recognition of his contributions to the knowledge of parasites and parasitic diseases of swine and sheep.

H. WILLIAM KOCH, chief, betatron section, National Bureau of Standards, in recognition of his contributions to nuclear physics, in particular to betatron applications, and his studies of the interactions of high energy gamma rays with matter.

S. A. MCKEE, chief, engines and lubrication section, National Bureau of Standards, in recognition of his contributions in the field of lubrication and wear.

RUSSELL B. SCOTT, chief, cryogenic section, National Bureau of Standards, in recognition of his contributions to cryogenic research, particularly his calorimetric investigations at low temperatures.

DOYS A. SHORB, parasitologist, Bureau of Animal Industry, in recognition of his extensive investigations of parasites and parasitic diseases of livestock.

MARY S. SHORB, research professor, department of poultry husbandry, University of Maryland, in recognition of her contributions to the science of nutrition, especially the development of methods of assay for vitamin B-12 and related investigations.

BANCROFT W. SITTERLY, professor of mathematics and associate dean, American University, in recognition of his contributions to astronomy, and in particular investigations on eclipsing binary stars, stellar magnitudes, and stellar parallaxes; also studies in the theory of hyperbolic systems of radio navigation, in particular the Loran system.

CHARLOTTE M. SITTERLY, physicist, spectroscopy section, National Bureau of Standards, in recognition of her contributions to astrophysics, in particular researches on the solar and sun spot spectra, and contributions to the study of atomic spectra and tables of atomic energy levels.

JOHN TODD, chief, computation laboratory, National Bureau of Standards, in recognition of his contribution to numerical analysis in particular, and to mathematics in general.

GEORGE B. VOGT, entomologist, Bureau of Entomology and Plant Quarantine, in recognition of his original and unusually searching work in insect biology and taxonomy, especially that dealing with Texan woodboring beetles.

KATHARINE WAY, physicist, National Bureau of Standards, in recognition of her contributions

to nuclear physics, in particular her work on binding energies and fission products.

HAROLD O. WYCKOFF, chief, X-ray section, National Bureau of Standards, in recognition of his contributions to radiation physics and in particular his researches on the protection requirements for electromagnetic radiations.

*Elected January 16, 1951*

FRANCIS A. ARNOLD, JR., associate director, National Institute of Dental Research, National Institutes of Health, in recognition of his contributions to dental research, and in particular his contributions to the epidemiology of dental caries with particular reference to the role of naturally occurring fluorine in water supplies.

ALFRED E. BROWN, assistant director, Harris Research Laboratories, in recognition of his work on the chemical modification of proteins, and in particular his researches on modification of wool and other fibrous proteins.

LYMAN FOURT, research associate, Harris Research Laboratories, in recognition of his work in the testing of textiles and in their evaluation for clothing.

A. R. GLASGOW, JR., chemist, National Bureau of Standards, in recognition of his studies in the separation, purification, and analysis of petroleum hydrocarbons.

EDWARD G. HAMPP, research associate, National Institutes of Health, in recognition of his fundamental contributions to knowledge of diseases of the oral cavity, and in particular his studies on oral spirochetes and the isolation of *Borrelia vincentii* in pure culture.

HARRY JOSEPH KEEGAN, physicist, National Bureau of Standards, in recognition of his contributions to optics, in particular his work in spectrophotometry and its application to the specification of color.

L. ROLAND KUHN, lieutenant colonel, chief, department of bacteriology, Army Medical Department Research and Graduate School, in recognition of his contributions to microbiology in particular his outstanding studies on *Cryptococcus hominis*.

LOUISE H. MARSHALL, physiologist, National Institute of Arthritis and Metabolic Diseases, National Institutes of Health, in recognition of her contributions to high-altitude physiology, particularly in respiration and renal hemodynamics.

WADE H. MARSHALL, research fellow, National Institutes of Health, in recognition of his con-

tributions to physiology, in particular his studies of the central nervous system, sensory areas, and pathways of the brain.

F. J. McCLURE, biochemist, National Institutes of Health, in recognition of his studies of the physiological effects of fluorine, particularly of the relation of fluoride to dental caries.

ANTHONY M. SCHWARTZ, manager, industrial chemicals division, Harris Research Laboratories, in recognition of his work on the preparation and utilization of surface-active agents, and the theory of their action.

WILLIE W. SMITH, physiologist, National Institutes of Health, in recognition of her contributions in physiology, particularly concerning renal function and radiation biology.

JOEL WARREN, chief, division of virus research and biophysics, Army Medical Service Graduate School, in recognition of his contributions to virus diseases, and in particular his researches on epidemic encephalitis and encephalomyocarditis.

*Elected February 12, 1951*

H. HERBERT HOWE, mathematician, U. S. Coast and Geodetic Survey, in recognition of his outstanding contributions to the theory of geomagnetism and numerous publications of magnetic data.

DAVID G. KNAPP, mathematician, U. S. Coast and Geodetic Survey, in recognition of his charting of geomagnetic data and the library classification of research data, especially in geomagnetism, magnetism, geoelectricity, and seismology.

M. LINDEMAN PHILLIPS, physicist, National Bureau of Standards, in recognition of her investigations in terrestrial magnetism and atmospheric electricity, and her studies of incandescent solids.

RALPH STAIR, physicist, National Bureau of Standards, in recognition of his work in radiometry, in particular the measurement of atmospheric ozone and the intensity and ultraviolet spectral distribution of the radiant energy from the sun.

*Elected April 16, 1951*

THOMAS J. HICKLEY, electrical engineer, U. S. Coast and Geodetic Survey, in recognition of his contribution to cartography through research and development of electronic hydrographic surveying equipment, particularly the electronic position indicator.

ROBERT W. LEUKEL, plant pathologist, Bureau

of Plant Industry, Soils, and Agricultural Engineering, in recognition of his outstanding contributions to plant pathology, especially with respect to seed treatments of cereals and the identification of the organism causing the Milo disease.

*Elected May 14, 1951*

HAIG DERMAN, cytologist, Bureau of Plant Industry, Soils, and Agricultural Engineering, in recognition of his outstanding researches on the cytology of plant hybrids and chimeras.

MONROE E. FREEMAN, chief, department of biochemistry, Army Medical Center, in recognition of his services as a teacher of chemistry and his research contributions in biochemistry.

RICHARD TOUSEY, head, micron waves branch, optics division, Naval Research Laboratory, in recognition of his work on solar spectroscopy from rockets, and spectroscopy in the vacuum ultraviolet region.

*Elected June 18, 1951*

LOUIS E. BARBROW, electrical engineer, National Bureau of Standards, in recognition of his contributions to photometry and lighting, and in particular to the development of federal and ASA standards and specifications for lamp and electrical supplies, for his establishment of new luminous flux values for mercury lamps, and for his effective furtherance, as secretary of the U. S. National Committee of the International Commission on Illumination, of international standards and practice in the field of lighting.

HOWARD S. BEAN, chief, capacity, density, and fluid meters section, National Bureau of Standards, in recognition of his work in metrology, especially his researches in the measurement of fluids, especially gases, with orifice meters.

ROGER W. CURTIS, physicist, ordnance development division, National Bureau of Standards, in recognition of his contributions and work in absolute measurement of electrical current, ultrasonic absorption in gases, electronics.

FLORENCE HOOPER FORZIATI, chemist, National Bureau of Standards, in recognition of her contributions to carbohydrate chemistry, and in particular her researches on the chemistry of cellulose.

WEBB E. HAYMAKER, chief, neuropathology, Armed Forces Institute of Pathology, in recognition of his contributions to experimental neuropathology.

JOSEPH VINCENT KARABINOS, chemist, National Bureau of Standards, in recognition of his contributions to organic chemistry, particularly on heparin, on reductive desulfurization, aromatic hydrocarbons, and the isolation of substances from natural sources.

BENJAMIN L. PAGE, physicist, National Bureau of Standards, in recognition of his work in metrology, especially in length and angle measurements.

JOHN THOMAS PRESLEY, plant pathologist, Bureau of Plant Industry, Soils, and Agricultural Engineering, in recognition of his work on the diseases of cotton, in particular his researches on the root rot of cotton and the breeding of disease-resistant varieties.

ROBERT FRANCIS REITEMEIER, soil scientist, Bureau of Plant Industry, Soils, and Agricultural Engineering, in recognition of his contributions to soil science, in particular his researches on metaphosphates, soil colloids, semimicroanalysis, and soil fertility.

MAURICE M. SHAPIRO, head, heavy particle physics branch, nucleonics division, Naval Research Laboratory, in recognition of his work in cosmic rays and in nuclear and pile physics.

KARL SOLLNER, chief biochemist, National Institutes of Health, in recognition of his extensive research into theory and experimental practice in the fields of physical chemistry of colloids as related to membranes, permeability, ultrasonics and osmosis; thixotropy; sols and gels; emulsions; and physical biochemistry.

RAY PALMER TEELE, JR., physicist, National Bureau of Standards, in recognition of his contributions to photometry and lighting, and in particular the development of the physical photometer, the photometry of phosphorescent materials, and his contributions to international agreement on photometric standards.

HORACE MAYNARD TRENT, head, applied mathematics branch, Naval Research Laboratory, in recognition of his work in electromechanical analogies and in mathematical theories of mechanics.

#### NONRESIDENT

*Elected May 15, 1950*

HARRY D. PRATT, scientist, U. S. Public Health Service, Atlanta, Ga., in recognition of his taxonomic studies of insects of economic importance, especially the parasitic Hymenoptera and the disease-carrying Diptera.

*Elected November 20, 1950*

WILLARD H. BENNETT, physics department, University of Arkansas, in recognition of his studies of negative ions in electrical discharges and gases.

COLIN CAMPBELL SANBORN, curator of mammals, Chicago Natural History Museum, in recognition of his contributions to systematic mammalogy, particularly the classification of the Chiroptera and faunal studies in South America.

CLAUDE E. SCHAEFFER, curator, Museum of the Plains Indian, Browning, Mont., in recognition of his contributions to the ethnography of the American Northwest and to the organization of scientific archeology in Pennsylvania.

*Elected December 18, 1950*

HAROLD J. HOGE, physical division, research department, Leeds Northrup Co., Philadelphia, Pa., in recognition of his contributions to thermometry, particularly in the range below the boiling point of oxygen.

*Elected January 16, 1951*

E. RAYMOND HALL, director, Museum of Natural History, University of Kansas, Lawrence, Kans., in recognition of his contributions to the systematic study of recent and fossil mammals, especially with regard to the fauna of western North America and to the mustelid carnivores.

ROBERT RAUSCH, parasitologist in charge, animal-borne disease section, Arctic Health Research Center, U. S. Public Health Service, Anchorage, Alaska, in recognition of his studies of host-parasite ecology, in particular the helminth parasites in wildlife and the relation of these diseases to public health.

S. F. SNIESZKO, director, microbiological laboratory, U. S. Fish and Wildlife Service, Kearneysville, W. Va., in recognition of his contributions to plant and fish diseases and in particular his studies of bacteria which cause fish diseases.

*Elected April 16, 1951*

EARL S. BELOTE, mathematician, U. S. Coast and Geodetic Survey, New York City, in recognition of his contribution to geodesy through research and development in the methods of adjusting the observational data from triangulation and traverse measurements.

*Elected May 14, 1951*

BIRDSALL N. CARLE, pathologist, U. S. Marine Hospital, New Orleans, La., in recognition of his

research in infectious diseases, particularly in the field of brucellosis.

GEORGE A. LLANO, research specialist, Headquarters Air University, U. S. Air Force, in

recognition of his contributions to the taxonomy and ecology of lichens and in particular his recent studies of the relation of these plants to arctic conditions.

## Obituaries

OWEN BERT FRENCH, geodesist, died at his home, Lakewood, Ohio, on February 1, 1951, ending a long, useful, and colorful career. He was born near Cleveland, Ohio, on December 17, 1865, the son of Marshall and Melissa A. French. He received a B.S. degree in 1888 and a C.E. degree in 1905, both at the Case School of Applied Science. On May 27, 1907, he married Marie Wilhelmine Schott, of Washington, D. C.

In 1889 Mr. French joined the U. S. Coast and Geodetic Survey, which he served until 1915. His work carried him throughout the United States as well as Alaska and Hawaii. His duties were many and varied and included topographic, hydrographic, magnetic, and astronomic surveys; on the last he became an authority. In 1894 he was in charge of scientific work on Walter Wellman's first polar trip. Early in the century he was engaged on astronomic work along the boundary between Alaska and British Columbia, in 1906 on triangulation and base measurements, as well as astronomic surveys along the United States-Canadian Boundary. He made the first investigation of invar (nickel steel) tapes for use in the measurement of base lines, proving them to be far superior to steel tapes for this purpose.

Mr. French retired from the Coast and Geodetic Survey in 1915 and practiced as a consulting geodesist in 1916-17. In 1918-19 he was a professor of geodesy and astronomy at the Institute of Military Surveying, Peking, China, where he was awarded the Wheat decoration. From 1920 to 1933 he was professor of surveying and astronomy at George Washington University, after which he continued his practice as a consulting geodesist.

Thorough and painstaking in all his work, Mr. French became well known at home and abroad as one of the leading practical geodesists of his time. He was author of many reports and papers, among which are *Invar tapes on the measurement of six primary base lines* and *Report on the Scheimpflug method of aerial photography*, and co-author of *Determination of the difference in longitude between each two of the stations Washington, Cambridge, and Far Rockaway*. He also wrote a large portion of Gillespie's *Higher surveying*.

Mr. French had been a member of the American Society for the Advancement of Science, American Society of Civil Engineers, Washington

Society of Engineers, Washington Academy of Sciences, Washington Board of Trade, American Association of College Professors, Philosophical Society of Washington, American Geophysical Union, and the Cosmos Club.

EARL K. FISCHER, who died on August 3, 1951, had served as chief of the organic coatings section of the National Bureau of Standards for slightly less than a year prior to his death. His previous assignment had been as consultant to several divisions of the Bureau on problems in the field of rheology. Before coming to the Bureau in 1949, Dr. Fischer was head of the physical chemistry division of the Institute of Textile Technology at Charlottesville, Va. From 1933 to 1945 he was a physical chemist with the Interchemical Corporation. During the early part of this period he was with the United Color and Pigment Co., a subsidiary of the Interchemical Corporation; he later transferred to the central research laboratories and was head of Interchemical's physical-chemistry laboratory from 1939 to 1945.

He was born in Milwaukee, Wis., on November 21, 1905. He received a B.A. degree in 1927 and an M.A. in 1928 from the University of Southern California and the Ph.D. in 1931 from the University of Wisconsin. He held a Stieglitz fellowship in physical chemistry at the University of Chicago for three years.

Dr. Fischer was the author of a recently published book, *Colloidal dispersions*, and many technical papers that reflect his extensive investigations in the fields of surface chemistry, rheology, pigment technology, and the special instruments and techniques he developed in the course of these studies. He was a member of the American Chemical Society, a Fellow of the American Association for the Advancement of Science, and from 1947 to 1949 he was the Secretary of the Society of Rheology. He was also a member of the American Institute of Physics, Textile Research Institute, Fiber Society, New York Academy of Sciences, Washington Academy of Sciences, Virginia Academy of Science, Society of Motion Picture Engineers, American Association of Textile Chemists and Colorists, Sigma Xi, Phi Beta Kappa, Phi Lambda Upsilon, and the New York Chemists' Club.



## Officers of the Washington Academy of Sciences

<i>President</i> .....	WALTER RAMBERG, National Bureau of Standards
<i>President-elect</i> .....	F. M. SETZLER, U. S. National Museum
<i>Secretary</i> .....	F. M. DEFANDORF, National Bureau of Standards
<i>Treasurer</i> .....	HOWARD S. RAPPLEYE, U. S. Coast and Geodetic Survey
<i>Archivist</i> .....	JOHN A. STEVENSON, Plant Industry Station
<i>Custodian and Subscription Manager of Publications</i>	HARALD A. REHDER, U. S. National Museum

### *Vice-presidents Representing the Affiliated Societies:*

Philosophical Society of Washington.....	A. G. McNISH
Anthropological Society of Washington.....	WALDO R. WEDEL
Biological Society of Washington.....	HUGH T. O'NEILL
Chemical Society of Washington.....	JOHN K. TAYLOR
Entomological Society of Washington.....	FREDERICK W. POOS
National Geographic Society.....	ALEXANDER WETMORE
Geological Society of Washington.....	A. NELSON SATRE
Medical Society of the District of Columbia.....	FRED O. COE
Columbia Historical Society.....	GILBERT GROSVENOR
Botanical Society of Washington.....	LEE M. HUTCHINS
Washington Section, Society of American Foresters.....	WILLIAM A. DAYTON
Washington Society of Engineers.....	CLIFFORD A. BETTS
Washington Section, American Institute of Electrical Engineers.....	A. H. SCOTT
Washington Section, American Society of Mechanical Engineers.....	RICHARD S. DILL
Helminthological Society of Washington.....	L. A. SPINDLER
Washington Branch, Society of American Bacteriologists.....	ANGUS M. GRIFFIN
Washington Post, Society of American Military Engineers.....	FLOYD W. HOUGH
Washington Section, Institute of Radio Engineers.....	HERBERT G. DORSEY
District of Columbia Section, American Society of Civil Engineers	MARTIN A. MASON

### *Elected Members of the Board of Managers:*

To January 1953.....	C. F. W. MUESEBECK, A. T. MCPHERSON
To January 1954.....	SARA E. BRANHAM, MILTON HARRIS
To January 1955.....	ROGER G. BATES, W. W. DIEHL

*Board of Managers*..... All the above officers plus the Senior Editor

*Board of Editors and Associate Editors*..... [See front cover]

*Executive Committee*.... WALTER RAMBERG (chairman), F. M. SETZLER, H. S. RAPPLEYE, WILLIAM A. DAYTON, F. M. DEFANDORF

*Committee on Membership*... E. H. WALKER (chairman), M. S. ANDERSON, R. C. DUNCAN, G. T. FAUST, I. B. HANSEN, D. B. JONES, DOROTHY NICKERSON, F. A. SMITH, HEINZ SPECHT, H. M. TRENT, ALFRED WEISSLER

*Committee on Meetings*... H. W. WELLS (chairman), WM. R. CAMPBELL, W. R. CHAPLINE, D. J. DAVIS, H. G. DORSEY, O. W. TORRESON

*Committee on Monographs* (W. N. FENTON, chairman):

To January 1953.....	R. W. IMLAY, P. W. OMAN
To January 1954.....	S. F. BLAKE, F. C. KRACEK
To January 1955.....	W. N. FENTON, ALAN STONE

*Committee on Awards for Scientific Achievement* (J. R. SWALLEN, general chairman):

*For Biological Sciences*..... J. R. SWALLEN (chairman), MARGARET PITTMAN, F. W. POOS, L. P. SCHULTZ

*For Engineering Sciences*..... R. C. DUNCAN (chairman), A. C. FIELDNER, WAYNE C. HALL, J. W. MCBURNEY, O. S. READING, H. L. WHITTEMORE

*For Physical Sciences*..... L. A. WOOD (chairman), F. S. DAFT, GEORGE W. IRVING, JR., J. H. McMILLEN

*For Teaching of Science*..... M. A. MASON (chairman), F. E. FOX, M. H. MARTIN

*Committee on Grants-in-aid for Research*..... L. E. YOCUM (chairman), H. N. EATON, K. F. HERZFELD

### *Committee on Policy and Planning:*

To January 1953.....	W. A. DAYTON (chairman), N. R. SMITH
To January 1954.....	H. B. COLLINS, JR., W. W. RUBEY
To January 1955.....	L. W. PARR, F. B. SILSBEE

*Committee on Encouragement of Science Talent* (A. T. MCPHERSON, chairman):

To January 1953.....	A. H. CLARK, F. L. MOHLER
To January 1954.....	J. M. CALDWELL, W. L. SCHMITT
To January 1955.....	A. T. MCPHERSON, W. T. READ

*Representative on Council of A. A. A. S.*..... F. M. SETZLER

*Committee of Auditors*..... C. L. GAZIN (chairman), LOUISE M. RUSSELL, D. R. TATE

*Committee of Tellers*... GEORGE P. WALTON (chairman), GEORGE H. COONS, C. L. GARNER

## CONTENTS

	Page
PHYSICS.—Preliminary report: Nonlinear absorption and dispersion of plane ultrasonic waves in pure fluids. C. TRUESDELL.....	33
MINERALOGY.—The nature of rock phosphates, teeth, and bones. DUNCAN McCONNELL.....	36
BOTANY.—Notes on some families of Formosan phanerogams. HUI-LIN LI.....	39
ENTOMOLOGY.—New species of Sarcophagini (Diptera: Sarcophagidae). SELWYN S. ROBACK.....	45
ENTOMOLOGY.—A new genus of Bruchidae affecting <i>Hibiscus</i> in Argentina (Bruchinae: Acanthoscelidini). J. C. BRIDWELL.....	49
HERPETOLOGY.—Two Brazilian frogs: <i>Hyla werneri</i> , n. nom., and <i>Hyla similis</i> , n. sp. DORIS M. COCHRAN.....	50
HELMINTHOLOGY.— <i>Hymenolepis johnsoni</i> , n. sp., a cestode from the vole <i>Microtus pennsylvanicus drummondii</i> . EVERETT L. SCHILLER.....	53
ZOOLOGY.—Geographical distribution of the species of nemertean of the Arctic Ocean near Point Barrow, Alaska. WESLEY R. COE.....	55
NEW MEMBERS OF THE ACADEMY:.....	59
OBITUARIES: Owen Bert French; Earl K. Fischer.....	64

06.75  
02/23

VOL. 42

MARCH 1952

No. 3

# JOURNAL

OF THE

# WASHINGTON ACADEMY OF SCIENCES

### BOARD OF EDITORS

WILLIAM F. FOSHAG  
U.S. NATIONAL MUSEUM

J. P. E. MORRISON  
U.S. NATIONAL MUSEUM

JOHN C. EWERS  
U.S. NATIONAL MUSEUM

### ASSOCIATE EDITORS

F. A. CHACE, JR.  
BIOLOGY

MIRIAM L. BOMHARD  
BOTANY

J. I. HOFFMAN  
CHEMISTRY

R. K. COOK  
PHYSICS AND MATHEMATICS

T. P. THAYER  
GEOLOGY

PHILIP DRUCKER  
ANTHROPOLOGY

C. W. SABROSKY  
ENTOMOLOGY

PUBLISHED MONTHLY

BY THE

WASHINGTON ACADEMY OF SCIENCES  
MOUNT ROYAL & GUILFORD AVES.  
BALTIMORE, MARYLAND

Entered as second class matter under the Act of August 24, 1912, at Baltimore, Md.  
Acceptance for mailing at a special rate of postage provided for in the Act of February 28, 1925  
Authorized February 17, 1949

## Journal of the Washington Academy of Sciences

This JOURNAL, the official organ of the Washington Academy of Sciences, publishes: (1) Short original papers, written or communicated by members of the Academy; (2) proceedings and programs of meetings of the Academy and affiliated societies; (3) notes of events connected with the scientific life of Washington. The JOURNAL is issued monthly. Volumes correspond to calendar years.

*Manuscripts* may be sent to any member of the Board of Editors. It is urgently requested that contributors consult the latest numbers of the JOURNAL and conform their manuscripts to the usage found there as regards arrangement of title, subheads, synonymies, footnotes, tables, bibliography, legends for illustrations, and other matter. Manuscripts should be typewritten, double-spaced, on good paper. Footnotes should be numbered serially in pencil and submitted on a separate sheet. The editors do not assume responsibility for the ideas expressed by the author, nor can they undertake to correct other than obvious minor errors.

*Illustrations* in excess of the equivalent (in cost) of one full-page halftone are to be paid for by the author.

*Proof*.—In order to facilitate prompt publication one proof will generally be sent to authors in or near Washington. It is urged that manuscript be submitted in final form; the editors will exercise due care in seeing that copy is followed.

*Unusual cost* of foreign, mathematical, and tabular material, as well as alterations made in the proof by the author, may be charged to the author.

*Author's Reprints*.—Reprints will be furnished in accordance with the following schedule of prices (approximate):

Copies	4 pp.	8 pp.	12 pp.	16 pp.	20 pp.	Covers
100	\$3.25	\$6.50	\$ 9.75	\$13.00	\$16.25	\$3.00
200	6.50	13.00	19.50	26.00	32.50	6.00
300	9.75	19.50	29.25	39.00	48.75	9.00
400	13.00	26.00	39.00	52.00	65.00	12.00

*Subscriptions* or requests for the purchase of back numbers or volumes of the JOURNAL or the PROCEEDINGS should be sent to HARALD A. REHDER, Custodian and Subscription Manager of Publications, U. S. National Museum, Washington 25, D. C.

*Subscription Rates* for the JOURNAL.—Per year..... \$7.50

Price of back numbers and volumes:	Per Vol.	Per Number
Vol. 1 to vol. 10, incl.—not available.*	—	—
Vol. 11 to vol. 15, incl. (21 numbers per vol.)	\$10.00	\$0.70
Vol. 16 to vol. 22, incl. (21 numbers per vol.)	8.00	0.60
Vol. 23 to current vol. (12 numbers per vol.)	7.50	0.90

\* Limited number of complete sets of the JOURNAL (vol. 1 to vol. 41, incl.) available for sale to libraries at \$348.50.

MONOGRAPH No. 1, "The Parasitic Cuckoos of Africa," by Herbert Friedmann. \$4.50

PROCEEDINGS, vols. 1-13 (1899-1911) complete..... \$25.00

Single volumes, unbound..... 2.00

Single numbers..... .25

*Missing Numbers* will be replaced without charge provided that claim is made to the Treasurer within 30 days after date of following issue.

*Remittances* should be made payable to "Washington Academy of Sciences" and addressed to the Treasurer, H. S. RAPPLEYE, 6712 Fourth Street, N.W., Washington 12, D.C.

*Exchanges*.—The Academy does not exchange its publications for those of other societies.

# JOURNAL OF THE WASHINGTON ACADEMY OF SCIENCES

VOLUME 42

March 1952

No. 3

ANTHROPOLOGY.—*Some applications of physical anthropology.*<sup>1</sup> ROBERT M. WHITE, Quartermaster Climatic Research Laboratory, Lawrence, Mass. (Communicated by T. D. Stewart.)

Just as some cultural and social anthropologists have adapted their particular fields to contemporary problems, so have some physical anthropologists drawn from their techniques and developed methods by which many problems of every-day living which involve dimensions of the human being may be subjected to scientific analysis and solved in an objective manner. Although the problems generally treated by fields of anthropology other than physical are more subtle and abstract in nature, their very subtlety and abstractness have presented challenges that have enabled professional anthropologists to engage in direct approaches to them, since they present fields of investigation in which no other people are prepared to engage. On the other hand, the physical anthropologist encounters large numbers of "experts" when he approaches any of the numerous problems he may solve or help to solve.

In general, we, as people, have become so well acquainted with all the various implements used by us physically that we suffer from the types of prejudices so well described by Gittler (1949). Clothing, furniture, automobiles, all are familiar to us from our early childhood. We develop specific ideas about them, aided considerably by advertising claims. Consequently, when we develop tired backs, or we feel cramped, we believe we are in the best furniture or clothing that can be

made and so we, as people are at fault. The dissenting opinion of the objective investigator, merely expressed as a viewpoint, immediately arouses our antagonism. "I paid \$150 for this suit, so it is perfect." "This automobile cost \$2,500, so it cannot be improved upon." Such reactions should be familiar to all of us. Since these reactions are encountered among laymen, it is easy to imagine the attitudes or opinions expressed by designers of clothing and other items with which we come into physical association. Men who have made fortunes in the designing of clothing are hard to convince when we argue that they might improve upon their procedures. One of the greatest handicaps in reaching a mutual understanding with the designer or the engineer is the necessary use of statistical knowledge in explaining the problem. No one professional group attempts to use applied statistics more than does that engaged in clothing design and construction. Grading between sizes and sizes themselves are really applied statistics, but the use made of modern statistical concepts among that group is practically archaic. Although mechanical design engineers have benefited from training in mathematics, little, if any, statistical method has been included.

Since we, as people, are so well acquainted with all the various articles we wear or use every day, it comes somewhat as a shock to us to find that so little consideration has been given to us, as people, in the design of those articles. The common reaction expressed by most persons who are at first confronted by the idea that all is not right with the world is one of perplexed questioning. "How have we gotten along so well, so

<sup>1</sup> Presented before the Anthropological Society of Washington, April 18, 1950. The opinions or assertions contained herein are the private ones of the writer as a physical anthropologist and are not to be construed as official or as necessarily reflecting the views of the Quartermaster Corps or the Department of the Army.

far, if this situation actually exists?" The answer is simple. The first chair was probably a stone or a log. Trial and error soon indicated its deficiencies. A pad of animal skin or grass considerably alleviated the concentration of pressures on the ischial tuberosities. By further trial and error a back was added, and so we have now a product, called a chair, which has shown little evolution from its primitive ancestor. Sporadically, claims are made that some chairs are functional. Seldom is the function specified. Rarely is it directed at comfort, objectively specified in terms of the human occupant. Claims are often made, but the proof is seldom present. Coincident with this situation in furniture is that existing in clothing. Design and size are considered to be integral. They are, but seldom does size have a known and provable relation to human bodily dimensions. It is of little interest to the designers of clothing that I wear a "size 38 Regular" in this year's style, and next year, even though my dimensions do not change, I wear a "size 40 Regular". The explanation is simple. I am a "38 Regular" in this year's style, and a "40 Regular" in next year's. Opposed to this type of free thinking is the plight of the retailer who stocks next year's inventory on the basis of this year's sales. The equalization occurs with a "stock reduction and clearance sale". Fortunately for the poor retailer, the designer and his style usually stay within three sizes in their variation, so that the retailer can operate at 80-85 percent efficiency.

All this should serve to orient us with the more direct aspects of the field into which physical anthropology has recently entered. Essentially, the scope lies almost within the range of engineering, whether it be termed as such, or whether it is such by method. In clothing, little has been accomplished which would warrant the term "engineering." In what is more commonly accepted as an engineering field, furniture, automobiles, etc., equally negligible accomplishments have been attained with specific reference to human beings. Two factors explain this condition. The first, and fundamentally the most important, is the lack of static and dynamic anthropometric data. Allied with this, although necessarily following it in

demand, is the lack of statistical knowledge required to obtain proper application. The second, and of equal practical importance, is the universal attitude that the accommodation of the human being is a factor in the general field of competition. Whole industries are willing to standardize sizes of fittings, such as rims of wheels on automobiles, in order to accommodate tires made by another industry, but the perfectly simple concept of standardization of accommodation for human beings has not yet been accepted. The various commercial airlines are encountering a serious problem as a result of this type of situation. Pilot accommodations vary considerably among various aircraft (King, 1948). Consequently, when the suggestion is made that savings in time and money could be achieved by through-routing of aircraft over different lines, the pilots refuse, and wisely so, to accept responsibility of piloting aircraft that have cockpit arrangements differing markedly from those with which they are familiar. The armed services have been striving for the past five or six years to accomplish some form of cockpit standardization, and have made some progress, but the fulfillment of their efforts has yet to be realized in operational aircraft (Randall, 1946b).

Therefore, when the physical anthropologist carefully measures large series of people, develops objective analyses, and proposes results to be introduced into the design of all types of personal equipment or of equipment which requires accommodation of the human being, only part of his work is done. Two parts remain. He must educate the designers in his way of thinking, and then he must collaborate with the designers in setting up experiments which will convert the anthropometric requirements into terms which will be familiar to them.

The various needs for the objective consideration of bodily dimensions should be obvious, in part, to the casual observer. Beginning with clothing (Randall, 1946a), these needs extend to furniture, both for comfort and for function, automobiles, trains, aircraft, and even housing. From the viewpoint of the applied physical anthropologist a person "wears" a house, in that he gains his greatest comfort and efficiency if the house "fits" him. Tired backs at the

kitchen sink and the laundry tub can be just as painful as if they resulted from sitting in an inefficient chair. Bodily motions can be just as inefficient in a small room as they can be in tight gloves or shoes (Callaghan and Palmer, 1944). The main objective, then, in applied physical anthropology is to attain the optimum "fit" and thus the proper "size" for the human beings involved.

Obviously, in most of the problems encountered, 100 percent efficiency is not expected. The degree to which efficiency can be obtained in any one item will be dependent upon its functional characteristics of "fit" and also upon the degree of variability of dimensions which it will be required to accommodate. A secondary factor which enters the picture is the economics involved. All these factors operate to produce a compromise which is considered optimum. For example, the kitchen sink is relatively tolerant of a considerable variation in stature, but not so much as to accommodate a range of 16 inches in stature commonly encountered among housewives. On the other hand, most housewives do not operate on a strict time and motion basis, even though it would be to their advantage to do so, if they could. Finally, building houses in various "sizes" in terms of wear by the housewife is not very economical. Therefore, a compromise between accommodation, efficiency, and cost is necessary. The common compromise is a standard sink height, with the cost at a minimum and the efficiency unknown. It would not seem unreasonable to consider another possible answer; a sink provided with a height adjustment. Cost would rise somewhat, but range of accommodation and increase in efficiency would result.

It is the goal of the investigator to provide information for the designer as to the requirements of accommodation. It is the goal of the designer to meet these requirements. Finally, it is the objective of both to obtain the optimum compromise at the minimum cost.

Thus, in the field of applied physical anthropology, the physical anthropologist occupies three successive positions. Initially, he is an anthropometrist in collecting the metric data. Secondly, he is a statistician in preparing the "specifications" which describe

the requirements. Finally, he is an applied physical anthropologist, analyzing the problem of the designer insofar as it relates to human bodily dimensions, and in providing for the designer, in concrete practical terms understandable to the designer, the measure of fulfillment of the requirements by the designer. Many times this last role permits the anthropologist, through his analysis, to suggest revisions in the original design which will improve its efficiency materially and often reduce its cost.

The part played by statistics in applied physical anthropology should not be underrated. It is the essential tool for converting anthropometry to engineering terms. The use made of statistical method by designers is limited at best. More often than not the concept of variability is ignored. Further the concept of accommodation of an optimum percentage (e.g., 90 percent) of a population is usually only estimated. A common design criterion is the accommodation of the "average." Two examples may serve to indicate how this is done. In the design of clothing, a new pattern is usually tested to prove its adequacy. This test is accomplished by construction of an "average" size, 36 or 38 Regular in men's garments. Revision may be necessary, but the final opinion is based upon the adequacy demonstrated by this size of garment tried on "average" men. Following this test, there are certain rules which are followed to develop the other sizes. However, experience has shown that these rules are only, at best, vaguely related to regressions which can be demonstrated by anthropometry and statistics.

In automotive design, considerable use is made of profile manikins (Randall, 1949c). These are constructed as "average men," complete with hat. If space is sufficient to accommodate this "average" man, the design is considered satisfactory. But, consider for a moment. The "average" man is about 69 inches tall and weighs about 150 pounds. Stature ranges between 61 and 77 inches, and weight between 110 and 250 pounds. Further, and apparently totally ignored, at least 33 percent of our automobiles are driven by women as well as by men. Women "average" about 64.5 inches tall and 135 pounds in weight, ranging

between 56.5 and 72.5 inches, and 90 to 200 pounds. If the automobile is to accommodate its drivers, the "average" man is too large to be "average" of drivers. Further, if the design is satisfactory for 90 per cent of its drivers, being adjustable for statures between about 61 and 70 inches, and weight between 110 and 210 pounds, it will certainly accommodate "average" drivers, and, consequently, the "average" manikin has only academic interest at best.

Situations such as those described above have been encountered so universally that there is good reason to suspect that the field of applied physical anthropology has considerable room to grow.

As of this writing at least three large and applicable series of anthropometric data have been accumulated in the United States. The first, on some 147,000 children (O'Brien and Girshik, 1939; O'Brien, Girshik, and Hunt, 1941), and the second, on about 14,700 women (O'Brien and Shelton, 1941) were collected by the Bureau of Home Economics, United States Department of Agriculture. The third, on about 135,000 Army men and 10,000 Army women represents a selected military population (Damon and Randall, 1944; Randall, 1948b). Some applications of the Department of Agriculture series have been made (Lonie, 1948; Staples and DeLury, 1949). Much wider applications of the military series have been accomplished over the past seven years. Since the Department of the Army and the Department of the Air Force are in a position to include anthropometric findings in their specifications, wide and effective applications are possible. The results can be quickly demonstrated and assessed. It is hoped that demonstrated results of the use of applied physical anthropology in the armed services will serve as stimuli to other agencies to incorporate similar approaches in their activities.

Frequently, such questions as "Why is the Army interested in physical anthropology?" or "How is the Army using physical anthropology?" are asked by laymen and even physical anthropologists as well. It is intended here to summarize present Army research in physical anthropology and to indicate some of the methods currently in use.

In some respects, it would seem that the use of physical anthropology by the military is a relatively new thing, at least in this country. The increasing use of applied physical anthropology, which is perhaps a more accurate term, is a comparatively new development. However, it is interesting to note that a book by B. A. Gould was published by the U. S. Sanitary Commission in 1869, entitled *Investigations in the military and anthropological statistics of American soldiers*, while in 1875 two volumes by J. H. Baxter were issued by the Government Printing Office under the imposing title of *Statistics, medical and anthropological, of the Provost-Marshall-General's Bureau, derived from records of the examination for military service in the Armies of the United States during the late War of the Rebellion, of over a million recruits, drafted men, substitutes, and volunteers*.

The extensive work of Davenport and Love (1921) during and following the first World War is familiar to most physical anthropologists. Measurements were obtained on 1,000,000 recruits, and also on 100,000 troops during demobilization. Although the emphasis was primarily statistical and clinical, some applications of the anthropometric data to clothing problems were carried out. Medical and clinical studies were continued through the last war under the Surgeon-General's Office, while the Selective Service System has issued several reports on medical statistics, dealing with such topics as physical examinations and causes for rejections of draftees.

As early as 1942, research in applied physical anthropology was started by the Army Air Forces. This work was carried on throughout the war, with the center of activity at the Aero-Medical Laboratory, Wright Field, Dayton, Ohio, and is being continued there. Several anthropometric surveys were carried out on flight personnel and the data obtained were used in connection with spatial requirements in aircraft and in the development of flight clothing and other types of personal equipment (Damon et al., 1944; Randall et al., 1946; Hertzberg, 1948).

After several years, the Army Quartermaster Corps carried out an anthropometric



survey in 1946. Approximately 96,000 Army separatees were processed at separation centers, while a small series of 8,500 inductees was also obtained. A series of about 9,000 women, consisting of WAC personnel and Army nurses, was measured. In conjunction with the anthropometric survey, somatotype photographs of approximately 50,000 men and 550 women were taken. This photographic material has been utilized by Hooton at Harvard University in extensive studies of body builds occurring in the Army population.

More recently, additional data have been secured in the form of smaller Army series. One year ago, a sample of 6,500 men, including draftees, enlistees and reenlistees, was measured at induction centers, while data on 2,000 marines were also obtained in 1949. Numerous smaller series of men have been measured from time to time in connection with various clothing fitting tests.

Since one of the primary responsibilities of the Office of The Quartermaster General is to clothe and equip Army men and women, applications of anthropometric data to clothing problems have received first consideration. However, there are still basic problems in the general field of human biology for which the accumulated Army anthropometric data should and can be used. Consequently, the Army program of research in physical anthropology may be considered to include both basic research and practical applications.

Obviously the human sample comprising the available Army data cannot be considered representative of the total population, since it is a selected group. There are various limiting factors, such as age, physical and medical qualifications, as well as social and economic factors. However, several types of investigation are possible with these data. One for example, is the problem of age change and terminal growth. Sufficient data are available to provide adequate series for each age from 17 through 32 years. Another problem involves the differences between military and non-military populations. How do draftees or enlistees entering the Army for the first time compare with separatees who have been exposed to the military environment for

various lengths of time? It is well-known that draftees, and especially 17-, 18-, or 19-year old enlistees tend to gain weight and that their body measurements change upon entering the Army. Do these changes take place rapidly within the first few weeks, do they extend over the whole period of basic training, or is it a more gradual process covering several years? These are questions of practical importance to those responsible for supplying and issuing Army clothing and equipment. Present studies utilizing the anthropometric data are focussed on these problems (Randall, 1949a).

Only preliminary reports on the Army work have been issued, since analyses of the extensive data have taken considerable time. A volume of the female data has been published, containing some 98 bivariate charts of 23 body measurements, together with 109 regression tables (Randall and Munro, 1949b).

Sorting of the male data and statistical analyses of some 37 body measurements have been completed, giving 72 bivariate charts and 83 regression tables. In addition, the male data have been sorted by age groups from 17 through 32 years, with bivariate and regression tables for each year of age. All this material is now ready for publication and will represent useful reference data.

A certain amount of sociological information is included along with the anthropometric data, such as location of birthplace, national extraction, birthplace and extraction of parents, education, civilian and military occupation, etc. Preliminary sortings on the basis of geographical area of birthplace and national extraction are now in progress.

The more recent data of a year ago are being sorted on the basis of classification—draftees, enlistees, reenlistees—as well as by age groups, for purposes of comparison with the earlier separatee and inductee material. The IBM system of punched cards and electrical sorting machines is used in all this work.

As has been mentioned previously, Army clothing has received first consideration in the applications of anthropometric data. It has been a gradual process, but marked

improvements have been and are being made in the fit of Army clothing. The old Army joke to the effect that there were only two sizes of clothing issued—too large and too small—has been disposed of.

Reduced to simplest terms, the aim of the Quartermaster Corps with respect to clothing is to fit the Army population with the best possible clothing in a minimum number of sizes, requiring the least amount of alteration. In addition, there is a further consideration which is the percentage of the population to be fitted with standard sizes. It is desirable to have this percentage as high as possible, since men outside of the range of standard sizes must be fitted with supplementary or special order sizes. These men are usually those whose body measurements fall at the upper or lower ends of the distribution curve, and who comprise the lowest percentage frequencies in the population.

Obviously, the clothing of several hundred thousand men is no small item, especially in terms of the taxpayers' dollars and cents. In this respect, it will be seen that in the proper applications of Army anthropometry with respect to clothing sizes, size systems and tariffs, significant contributions can be made, particularly in the elimination of waste resulting from incorrect sizes. The Army cannot afford the trial and error methods of the clothing industry with respect to size, nor can it afford the cost of frequent or numerous alterations.

The applications of anthropometry to clothing consist, essentially, of relating body dimensions to clothing sizes (Randall, 1948a). This procedure has necessitated a definition of the Army population in metric terms in order to obtain a measure of the ranges and variations which occur. The metric definition of the population, together with the establishment of normal distribution curves, is the most useful advance made thus far (Randall, 1949b; Randall and Munro, 1949a).

Initially, the anthropometric data were used in investigating deficiencies in the size systems of standard clothing items already in use. In several cases, this resulted in recommendations that some smaller sizes be procured, since many smaller men at the

lower end of the distribution curve were not being fitted properly.

Another use of the data has been in the preparation of clothing tariffs. A tariff is a listing of the numbers of each clothing size required for the population, in terms of a given ratio, such as number per 1000, or per 100,000, as the case may be. For example, such tariffs for clothing items were prepared when the Universal Military Training program was first under consideration. Tariffs were also prepared when the recent post-war draft went into effect.

Even more profitable applications of anthropometry have been made in the development of new and improved items of clothing. In some cases it has been necessary to investigate various body measurements in order to determine just which dimensions are critical and important in the fit of clothing. It has been found that although upper body clothing, such as coats and jackets, traditionally has been sized on the basis of chest circumference, actually shoulder circumference and even waist circumference are more important than chest with respect to tolerances and fit. For example, a new system of sizing trousers on the basis of the seat dimension rather than the waist may result in a reduction of standard trouser sizes from 95 to only 30 sizes, which would be quite a saving. The sizes and tariffs for the new Air Force blue uniform were developed through the use of anthropometric data.

The applications of anthropometric data are not limited to body clothing by any means. Measurements of the head and face were used during the war in the development of gas masks, oxygen masks, goggles, and helmets (Randall and Damon, 1943). The anthropometry of the foot and the proper fit of all types of boots and shoes is a large problem in itself. A study of the hand and the functional fit of handwear has recently been initiated. It is hoped that the use of anthropometric data eventually may be extended to other types of military equipment: sleeping bags, tents, tanks, etc. The necessity for anthropometric specifications in aircraft and submarines where spatial requirements are critical is obvious.

The criticism has been made that Army

anthropometry on such a scale is unsatisfactory from the standpoint of technique. Some anthropologists even feel that as far as clothing is concerned, tailors could do just as well, and that we are wasting time and effort in attempting to apply the methods of physical anthropology to such a problem as Army clothing. The point is that clothing people are basically artists, and not human biologists, and they do not have sufficient knowledge of such topics as normal distributions of body measurements or applied statistics. Here is one field in which the trained professional anthropologist can make a practical contribution.

In closing, mention should be made of the late Francis E. Randall, who, perhaps more than any other, was responsible for the development of applied physical anthropology in the Army. He began his work with the Air Force during the war, and then came to the Quartermaster Corps in 1946 to direct the anthropometric survey. He really believed in applied physical anthropology, to the extent that had he lived, he probably would have found ways to incorporate anthropometric data in the working height of the kitchen sink or the handle of an egg-beater, not to mention automobiles or office furniture.

#### LITERATURE CITED

- BAXTER, J. H. *Statistics, medical and anthropological, of the Provost-Marshall-General's Bureau, derived from records of the examination for military service in the Armies of the United States during the late War of the Rebellion, of over a million recruits, drafted men, substitutes and volunteers*, 2 vols. Washington, 1875.
- CALLAGHAN, J., and PALMER, C. *Measuring space and motion*. Family living as the basis for dwelling design, vol. 5: Research study no. 6. John B. Pierce Foundation, New York, 1944.
- DAMON, A., and RANDALL, F. E. *Physical anthropology in the Army Air Forces*. Amer. Journ. Phys. Anthropol., n. s., **2**: 219-316. 1944.
- DAMON, A., RANDALL, F. E., BENTON, R. S. and BRUES, A. M. *The importance of human sizing standards in aviation*. Journ. Aviation Med. **15**: 238-243. 1944.
- DAVENPORT, C. B., and LOVE, A. G. *Army anthropology: based on observations made on draft recruits, 1917-1918, and veterans at demobilization, 1919*. Medical Department of the United States Army in the World War, vol. 15: Statistics, pt. 1. 1921.
- GITTLER, J. B. *Man and his prejudices*. Sci. Monthly **69**: 43-47. 1949.
- GOULD, B. A. *Investigation in the military and anthropological statistics of American soldiers*. U. S. Sanitary Commission. New York, 1869.
- HERTZBERG, H. T. E. *Postwar anthropometry in the Air Force*. Amer. Journ. Phys. Anthropol., n. s., **6**: 363-371. 1948.
- KING, B. G. *Measurements of man for making machinery*. Amer. Journ. Phys. Anthropol., n. s., **6**: 341-352. 1948.
- LONIE, M. *Anthropometry and apparel*. Amer. Journ. Phys. Anthropol., n. s., **6**: 353-361. 1948.
- O'BRIEN, R., and GIRSHIK, M. A. *Children's body measurements for sizing garments and patterns. A proposed standard system based on height and girth of hips*. U. S. Dept. Agr., Misc. Publ. 365. 1939.
- O'BRIEN, R., GIRSHIK, M. A. and HUNT, E. P. *Body measurements of American boys and girls for garment and pattern construction. A comprehensive report of measuring procedures and statistical analysis of data on 147,000 American children*. U. S. Dept. Agr. Misc. Publ. 366. 1941.
- O'BRIEN, R., and SHELTON, W. C. *Women's measurements for garment and pattern construction*. U. S. Dept. Agr. Misc. Publ. 454. 1941.
- RANDALL, F. E. *Garment size and the retailer*. Department Store Economist, July and August, 1946a.
- . *Seat comfort*. Mechanical Engineering **68**: 1056-1058. 1946b.
- . *Applications of anthropology to the determination of size in clothing*. Environmental Protection Series, Report no. 133. Quartermaster Climatic Research Laboratory, Lawrence, Mass., 1948a.
- . *Anthropometry in the Quartermaster Corps*. Amer. Journ. Phys. Anthropol., n. s., **6**: 373-380. 1948b.
- . *Age changes in young adult army males*. Human Biology **21**: 187-198. 1949a.
- . *Anthropometric nomograph of Army men*. Human Biology **21**: 218-232. 1949b.
- . *Theory and practice in the use of scale manikins*. Iowa Transit, December 1949c.
- RANDALL, F. E., and DAMON, A. *An interesting application of a basic science to aviation medicine*. Journ. Aviation Med. **14**: 200-205. 1943.
- RANDALL, F. E., DAMON, A., BENTON, R. S., and PATT, D. I. *Human body size in military aircraft and personal equipment*. U. S. Army Air Forces Technical Rep. 5501. Air Materiel Command, Wright Field, Dayton, Ohio, 1946.
- RANDALL, F. E., and MUNRO, E. H. *Anthropometric nomograph of Army women*. Environmental Protection Section Rep. 148. Quartermaster Climatic Research Laboratory, Lawrence, Mass., 1949a.
- . *Reference anthropometry of Army women*. Environmental Protection Section Rep. 149. Quartermaster Climatic Research Laboratory, Lawrence, Mass., 1949b.
- STAPLES, M. L., and DELURY, D. B. *A system for the sizing of women's garments*. Textile Research Journal **19**: 346-354. 1949.

GEOLOGY.—*Paleozoic of western Nevada*. H. G. FERGUSON,<sup>1</sup> U. S. Geological Survey.

The stratigraphic and structural history of western Nevada during the Paleozoic differs fundamentally from that of the rest of the Great Basin. In eastern and central Nevada and southern California, the Paleozoic section, at least above the Lower Cambrian, is largely limestone and dolomite. The formations, particularly those older than the Carboniferous, are fairly continuous; unconformities and unconformities are rare except at the margins of the area; and volcanic rocks are absent.

Within the western area, roughly north of lat. 37°30' and west of an irregular line between long. 116° and 117°, there is an entirely different Paleozoic section, whose nearest lithologic similarities are with northern California and central Oregon. Quartzite, slate, and chert are the prevailing rock types, volcanic rocks are abundant, and carbonate rocks are subordinate. Crustal instability during the Paleozoic is recorded not only by unconformities and major gaps in the sections, but also by several episodes of folding and thrusting, one of which can be dated approximately as Mississippian or Pennsylvanian and another as early Permian. These were followed by major diastrophism within the Jurassic.

Further study is needed to determine whether, during early as well as late Paleozoic (Nolan, 1928), a barrier of some sort separated the two areas, as suggested by the differences in lithology, by the gaps in the sections, and by numerous unconformities and unconformities both east and west of the inferred barrier. On the other hand, lack of observed gradation between the eastern and western facies may be due to the fact that along at least a part of the border zone between the areas thrusting has carried the rocks of the western facies eastward, possibly as much as 30 or 40 miles; to the south, the western facies is separated from the eastern facies of the Panamint and Inyo Ranges by a broad belt, largely unexplored, in which the only Paleozoic rocks known are Lower Cambrian.

The following notes on the lithology of the western Nevada Paleozoic formations are based chiefly on the results of U. S. Geological Survey reconnaissance by the writer and his associates, S. W. Muller, R. J. Roberts, and S. H. Cathcart. The area covered consists of three one-degree quadrangles: the Sonoma Range quadrangle, lat. 40°-41°, long. 117°-118°, comprising four 30-minute quadrangles — Winnemucca (Ferguson, Muller, and Roberts, 1951); Mount Tobin (Muller, Ferguson, and Roberts, 1951); Golconda (Ferguson, Roberts, and Muller, in press); and Mount Moses (Ferguson, Muller, and Roberts, 1951); and the Hawthorne and Tonopah quadrangles, lat. 38°-39°, long. 117°-119° (Ferguson and Muller, 1949). In addition to the reconnaissance studies, more detailed mapping was done by Roberts in the Antler Peak 15-minute quadrangle (Roberts, 1951) in the northeastern part of the Sonoma Range quadrangle. Mapping by James Gilluly is in progress in three 15-minute quadrangles (Mount Lewis, Crescent Valley, and Cortez), east of the southern part of the Sonoma Range quadrangle, and by Preston E. Hotz in the Osgood Mountain quadrangle to the north. A vast area remains unexplored, and much additional field work is needed.

*Cambrian*.—In the Hawthorne and Tonopah quadrangles, the fossiliferous Lower Cambrian rocks are largely quartzite and slate, with subordinate dolomite and limestone. No Middle or Upper Cambrian has been identified, though Upper Cambrian has been reported by Turner (1902) in the Silver Peak quadrangle to the south. These rocks are overlain apparently conformably by Ordovician rocks of the western facies (Ferguson and Muller, 1949, pp. 45-52). In the Sonoma Range quadrangle thick unfossiliferous quartzite, presumably of Lower Cambrian age, is overlain by several thousand feet of slate with minor amounts of dolomite and limestone of Upper or Middle Cambrian age (Ferguson, Roberts, and Muller, in press). These show no lithologic similarity to the better-known dominantly carbonate formations in the ranges to the east.

<sup>1</sup> Published by permission of the Director, U. S. Geological Survey.

*Ordovician.*—Ordovician rocks are present in great thickness and variety throughout the entire western area. In the Tonopah and Hawthorne quadrangles (Ferguson and Muller, 1949) they consist largely of dark cherts, graptolite-bearing slates, and quartzites. In the Sonoma Range quadrangle and neighboring quadrangles to the east, there are also andesitic lavas and breccias (Roberts, 1951; Ferguson, Muller, and Roberts, in press). The proportions of the various rocks vary greatly in different areas. Carbonate rocks, which form most of the section in central and eastern Nevada, are scarce.

Along the eastern border of the area, a thrust has superposed the slaty rocks of the western facies Ordovician above the carbonate eastern facies. The western facies of the upper plate is known to extend as far to the east as the Sulphur Spring Mountains, about lat.  $39^{\circ}45'$ , long.  $116^{\circ}05'$  (Merriam and Anderson, 1942). The same thrust relations of the two facies are also present in the Cortez quadrangle, lat.  $40^{\circ}10'$ , long.  $116^{\circ}40'$  (Gilluly, personal communication). It is possible that a thrust contact is also present to the southward, for at Belmont, about lat.  $38^{\circ}35'$ , long.  $116^{\circ}55'$ , the Ordovician consists of characteristic western facies with graptolite-bearing slate (Ferguson, 1924, p. 23), while the eastern facies, including the Pogonip limestone and Eureka quartzite, is present at Tybo, 30 miles southeast (Ferguson, 1933, pp. 16-20). The western facies is known to extend southward as far as the southern border of the Silver Peak quadrangle, lat.  $37^{\circ}30'$  (Turner, 1902). Fifty miles to the south, at the northern end of the Panamint Range, are the characteristic carbonate rocks and Eureka quartzite of the eastern facies (McAllister, 1947). In the largely unexplored region between these two areas the only known Paleozoic rocks are of Cambrian age.

*Silurian.*—No rocks of Silurian age have yet been found in the western area, although thick Silurian formations of carbonate rocks are known along its eastern border, as far west as long.  $116^{\circ}50'$ . The westernmost sections include shaly limestones carrying graptolites (Kirk, 1933, p. 34; Gilluly, personal communication).

*Devonian.*—Devonian is known at two localities in the western area; in the San Antonio Mountains about 8 miles north of Tonopah (about lat.  $37^{\circ}10'$ , long.  $117^{\circ}10'$ ) and in the northeastern part of the Mount Lewis quadrangle (near lat.  $40^{\circ}30'$ , long.  $116^{\circ}45'$ ).

The Devonian of the San Antonio Mountains

consists of about 1,000 feet of limestone containing a fauna referred to Middle Devonian. This rests with a small angular unconformity on the characteristic Ordovician chert and slate of the western facies, although the lithology and fauna suggest correlation with Devonian carbonate formations to the east.

In the Mount Lewis quadrangle (Gilluly, personal communication) the Devonian is entirely different in lithology and consists of about 4,000 feet of dark chert and sandstone with subordinate slate, and a few thin beds of limestone which have yielded identifiable fossils. No volcanic rocks are present. The formation is in thrust contact with the Ordovician of the western facies and its relation to other formations is unknown. Except for the absence of volcanic rocks, the lithology is similar to that of parts of rocks mapped as Pennsylvanian (?) in the Sonoma Range quadrangle (Pumpernickel formation) and it is possible that more detailed study will show that Devonian is also present in the Sonoma Range quadrangle.

*Carboniferous.*—No formations of Carboniferous age are present in the Hawthorne and Tonopah quadrangles, where Permian rocks rest unconformably on highly folded Ordovician slate and chert. In the Sonoma Range quadrangle, however, there is a puzzling complex of formations of probable Mississippian and known Pennsylvanian age (Roberts, 1951). A great thrust, the Golconda thrust (Ferguson, Roberts, and Muller, in press), probably of Jurassic age, brings together completely different Carboniferous and Permian formations. Further complexity is caused by thrusting within both plates during at least two periods; in late Mississippian or early Pennsylvanian in the lower plate, and within the Permian in the upper plate.

Below the thrust, there are two formations of probable Mississippian age. These are themselves in thrust contact, and both are overlain by lower Pennsylvanian conglomerate. The Scott Canyon formation (Roberts 1951), present only in the eastern part of the Antler Peak quadrangle, consists of andesitic meta-volcanic rocks and chert, with some argillite. A thin bed of limestone yielded fossil sponges, considered to be not older than Carboniferous (Helen Duncan, personal communication).

The Harmony formation is unfossiliferous and consists essentially of micaceous arkosic grit and micaceous quartzite that locally attain a considerable thickness. Derivation from a granitic

or gneissic land mass to the west, perhaps in the area now occupied by the Sierra Nevada batholith, seems to be implied. Probable persistence of such a land mass throughout most of late Paleozoic time is suggested by recurrence of beds of similar arkosic material in the Pennsylvanian and Permian clastic formations of the area.

The Battle formation, consisting of conglomerate and pebbly limestone of lower Pennsylvanian age (Roberts, 1951), was deposited across the thrust contact of the Scott Canyon and Harmony formations. No correlation with formations in the east has yet been established.

Disconformably above the Battle formation is the Antler Peak limestone of upper Pennsylvanian and possibly lower Permian (?) age (Roberts, 1951). The fauna of the limestone, according to J. S. Williams (personal communication), resembles Alaskan and Russian species. At present this limestone is known only in the northeastern part of the Sonoma Range quadrangle and the Osgood Mountain quadrangle to the north (Hobbs, 1948).

In the upper plate of the Golconda thrust, the thick Pumpnickel formation, largely andesitic volcanics, chert, and argillite, is tentatively assigned to the Pennsylvanian, as it is overlain conformably by sedimentary formations of lower Permian (?) age (Roberts, 1951; Muller, Ferguson, and Roberts, 1951). This formation has not yet been traced outside the Sonoma Range quadrangle, but it is probably present in the Osgood Mountain quadrangle to the north (Hobbs, 1948).

*Permian.*—Permian rocks of the Sonoma Range quadrangle (Roberts, 1949, 1950; Ferguson, Roberts, and Muller, 1951) also differ on the two plates of the Golconda thrust. Below the thrust the Edna Mountain formation, consisting primarily of quartzite, in part micaceous, conglomerate, limestone, and slate, rests disconformably on the Pennsylvanian and Permian (?) limestone. This formation contains the same fauna as the well-known Phosphoria formation of the eastern part of the Great Basin and may represent a clastic marginal facies.

The upper plate of the thrust carries two formations not found in contact, but both overlie conformably a thick sequence of dominantly metavolcanic rocks assigned to the Pennsylvanian. In the central part of the Sonoma Range quadrangle the Havallah formation is 10,000 feet or more thick and consists of quartzite carrying feldspar in part, with interbedded chert,

subordinate slate, and thin limestone beds. Near the base of the formation the limestone contains fusulinids of Wolfeamp and probably Leonard age (Roberts, 1951). Along the western edge of the quadrangle and tentatively correlated with the Havallah formation, is the Leach formation containing a larger proportion of coarser clastics including conglomerate, graywacke, impure quartzite in part arkosic, together with slate and a little limestone in the upper part (Muller, Ferguson, and Roberts, 1951). No determinable fossils were obtained from these, and a thrust separates them from the more quartzitic Havallah formation of the central part of the quadrangle. It seems a reasonable inference that it may be merely a more coarsely clastic facies. If so, a western source for both formations is implied.

Folding, accompanied by some thrusting and followed by deep erosion, preceded the youngest Permian unit of the Sonoma Range quadrangle, the dominantly volcanic Koipato formation. This differs from the older volcanic formations in that the lavas are in part siliceous, and are less metamorphosed. The Koipato formation overlies the Permian (?) of the upper plate facies with marked angular unconformity and is overlain unconformably by Triassic rocks, but with angular discordance of only a few degrees at most. Its greatest known thickness, 14,000 feet (Knopf, 1924; Wheeler, 1939), is a few miles west of the Sonoma Range quadrangle, but within the quadrangle it thins out completely to the east (Ferguson, Roberts, and Muller, in press). It is known, however, to extend some distance to the south and southwest. It has not been found below the Golconda thrust, so its relation to the Permian sedimentary rocks with Phosphoria fossils is not determinable in the Sonoma Range quadrangle.

In the Tonopah and Hawthorne quadrangles, the Permian sedimentary rocks containing the Phosphoria fauna lie unconformably on folded Ordovician rocks (Ferguson and Muller, 1949, pp. 45-52). In the southern part of the area these sedimentary rocks consist of 400 feet or less of grit and quartzite that locally grade laterally into dolomite. The formation is disconformably overlain by Lower Triassic and locally the Permian was completely eroded before Triassic deposition.

In contrast to the thin Permian of the south, the Toyabe Range in the northeast part of the Tonopah quadrangle contains a thickness of

about 6,000 feet of sedimentary and volcanic rocks assigned to the Permian, though fossiliferous only in the lower part. The upper part of the sequence is principally chert and meta-andesite with interbedded sedimentary rocks similar to those of the lower part. Fine-grained silicic intrusive rocks similar in composition to the lavas of the Koipato formation cut these rocks, but were not found in areas underlain by Triassic rocks. It is therefore possible that the Koipato formation may be somewhat younger than the sedimentary rocks containing Phosphoria fossils.

## REFERENCES

- FERGUSON, H. G. *Geology and ore deposits of the Manhattan district, Nevada*. U. S. Geol. Surv. Bull. 723. 1924.
- . *Geology of the Tybo district, Nevada*. Univ. Nevada Bull. 27 (3). 1933.
- FERGUSON, H. G., and MULLER, S. W. *Structural geology of the Hawthorne and Tonopah quadrangles, Nevada*. U. S. Geol. Surv. Prof. Pap. 216. 1949.
- FERGUSON, H. G., ROBERTS, R. J., and MULLER, S. W. *Golconda quadrangle, Nevada*. U. S. Geol. Surv. Geologic Quadrangle Map Series. (In press.)
- FERGUSON, H. G., MULLER, S. W., and ROBERTS, R. J. *Winnemucca quadrangle, Nevada*. U. S. Geol. Surv. Geologic Quadrangle Map Series. 1951.
- HOBBS, S. W. *Geology of the northern part of the Osgood Mountains, Humboldt County, Nevada*. U. S. Geol. Surv., Open file report. 1948.
- KIRK, EDWIN. *The Eureka quartzite of the Great Basin Region*. Amer. Journ. Sci., ser. 5, 26: 27-44. 1933.
- KNOPF, ADOLPH. *Geology and ore deposits of the Rochester district, Nevada*. U. S. Geol. Surv. Bull. 762. 1924.
- MCALLISTER, J. F. *Memorandum report on the geology of the northeastern part of Ubehebe Peak quadrangle, California*. Manuscript, U. S. Geol. Survey files. 1947.
- MERRIAM, C. W., and ANDERSON, C. A. *Reconnaissance survey of the Roberts Mountains, Nevada*. Bull. Geol. Soc. Amer. 53: 1675-1728. 1942.
- MULLER, S. W., FERGUSON, H. G., and ROBERTS, R. J. *Mount Tobin quadrangle, Nevada*. U. S. Geol. Surv. Geologic Quadrangle Map Series. 1951.
- NOLAN, T. B. *A late Paleozoic positive area in Nevada*. Amer. Journ. Sci., ser. 5, 16: 153-161. 1928.
- ROBERTS, R. J. *Geology of the Antler Peak quadrangle, Nevada*. U. S. Geol. Surv., Open file report. 1949.
- . *Antler Peak quadrangle, Nevada*. U. S. Geol. Surv. Geologic Quadrangle Map Series. 1951.
- TURNER, H. W. *A sketch of the historical geology of Esmeralda County, Nevada*. Amer. Geol. 29: 261-272. 1902.
- WHEELER, H. E. *Helicoprion in the Anthracolithic (late Paleozoic) of Nevada and California, and its stratigraphic significance*. Journ. Pal. 13: 103-114. 1939.

PALEONTOLOGY.—*Some new species of crinoids from the Henryhouse formation of Oklahoma*.<sup>1</sup> HARRELL L. STRIMPLE, Bartlesville, Okla. (Communicated by Alfred R. Loeblich, Jr.)

This paper is the first of a series to be devoted to echinoderms of Silurian age. The genera dealt with are *Allocrinus*, *Zophocrinus*, *Gnorimocrinus*, *Bactrocrinites*, *Hexacrinites*, and *Synbathocrinus*. All except the last three are known from rocks of Brownsport age; however, the species from the Henryhouse exhibit some decided, and probably significant, variances from the norm of the genera involved. The last three genera are not reported elsewhere from strata of Silurian age but are found in rocks of Devonian age.

<sup>1</sup>Numerous individuals have contributed directly or indirectly to this study. Dr. G. A. Cooper, Dr. A. R. Loeblich, Jr., and Arthur Bowsher, of the U. S. National Museum, and Dr. W. E. Ham, of the Oklahoma Geological Survey, have directed the author in field studies and/or have lent speci-

Genus *Hexacrinites* Austin and Austin, 1843

*Hexacrinites adaensis*, n. sp.

Figs. 4, 5

Dorsal cup is somewhat elongate bell-shaped. The lateral sides rise evenly above the columnar

mens for description and comparison. Dr. Edwin Kirk, of the U. S. Geological Survey, Dr. R. S. Bassler, of the U. S. National Museum (retired), Dr. Hertha Sieverts-Doreck, of Stuttgart, Germany, and Dr. G. Ubachs, of Liège, Belgium, have assisted in taxonomic and technical problems. Richard and Russell Alexander, at present students at the University of Oklahoma, William T. Watkins, of San Antonio, Tex., and Mr. and Mrs. Allen Graffham, of Purcell, Okla., have assisted considerably in field work and through contribution of many fine specimens. The author's wife, Mrs. Melba Strimple, has found many splendid specimens in both the Henryhouse of Oklahoma and the Brownsport of Tennessee.

attachment, then expand rapidly for a short distance, after which further expansion is gradual. There are three unequal BB, the smallest right posterior in position. Slightly over half the cup height is composed of the elongated RR and anal X. The five RR have small arm articulating facets, which are directed outwardly. The single anal plate is comparable in size to the r. post. R, and both are smaller than other RR.

Columnar cicatrix is round. Arms and tegmen are unknown.

*Measurements in mm.*—As follows:

Height of dorsal cup .....	13.0
Maximum width of cup .....	12.0*
Height of BB circlet (maximum) .....	6.9
Diameter of columnar scar .....	3.0

\* Mildly distorted by lateral compression.

*Remarks.*—*H. adaensis* is the only representative of the genus reported at present from rocks of Silurian age. The distinctive contour of the cup is sufficient to distinguish the species from other described forms.

*Holotype.*—Collected by the author. To be deposited in the U. S. National Museum.

*Occurrence and horizon.*—SW1/4NW1/4NW 1/4 sec. 33, T. 3 N., R. 6 E., south of Ada, Pontotoc County, Okla.; Henryhouse formation (upper), Silurian.

Genus *Synbathocrinus* Phillips, 1836

*Synbathocrinus antiquus*, n. sp.

Figs. 1-3

Dorsal cup is elongated and narrow until the distal extremity is approached, at which point there is a strong, outwardly directed flexing. There are three erect BB, the smaller in left anterior position. Five RR are of equal size and are very elongated. A well-developed notch is present between r. post. and l. post. BB for reception of an anal plate. This groove continues into the interarticulating areas. Arm articulating facets are distinctive; the outer ligamental furrow is very thin and is bordered to the exterior by a well-crenulated lip and to the interior by a slight ridge; muscle areas are shallowly depressed and thereafter the facets curve strongly upward so that a domelike structure is formed, almost covering the body cavity. In the uplifted area, a narrow slit divides each facet into two equal parts. Unless carefully examined, the domelike structure has the appearance of an oral circlet.

PBBr are quadrangular, slightly wider than high. The proximal columnal is round, thick and expanded in midsection. A minute, pentalobate lumen pierces the column.

*Measurements in mm.*—As follows:

	<i>Holotype</i>
Height of dorsal cup .....	9.4
Maximum width of cup .....	7.6
Height of BB circlet .....	3.7
Width of BB circlet .....	3.7
Diameter of proximal columnal .....	2.2

*Remarks.*—The unique appearance of *S. antiqus* is not closely approached by any other described species, and no other representative of the genus is recorded from Silurian strata.

*Types.*—Holotype collected by William T. Watkins, one paratype collected by Richard Alexander and one by the author. To be deposited in the U. S. National Museum.

*Occurrence and horizon.*—Near center of sec. 4, T. 2 N., R. 6 E., south of Ada, Pontotoc County, Okla., the type locality. Paratypes from SW1/4 NW1/4NW1/4 sec. 33, T. 2 N., R. 6 E., Pontotoc County; Henryhouse formation (upper), Silurian.

Genus *Zophocrinus* S. A. Miller, 1892

*Zophocrinus angulatus*, n. sp.

Figs. 6, 7

Dorsal cup is elongated and angular. There are four lateral sides marked by sharp longitudinal ridges. A horizontal ridge about 0.4 mm below the summit marks the termination of the cup angulation and the uppermost portion is circular in outline. In the proximal region is a slight twisting which causes inequality in the width of facets and there is a wafer-thin ridge marking the lowermost edge of the cup. Viewing the cup from below, there is an almost triangular outline. Three BB form almost half the length of the cup and four RR the balance. Arm articulating facets have not been observed in any of the specimens at hand. Sutures of the cup are not impressed. Proximal columnal is round, thin and small.

*Measurements in mm.*—As follows:

	<i>Holotype</i>	<i>Paratype</i>
Height of dorsal cup .....	9.3	10.3
Maximum width of cup .....	5.5	5.6
Height of BB circlet .....	4.5	4.7
Maximum width of BB circlet .....	4.7	5.1
Diameter of stem attachment .....	1.1	1.4

*Remarks.*—The strong angulation characteristic of *Z. angulatus* is sufficient to distinguish it from other described species.

*Types.*—Holotype collected by the author. Paratype collected by Richard Alexander. To be deposited in the U. S. National Museum.

*Occurrence and horizon.*—Center SW1/4NW 1/4 sec. 33, T. 3 N., R. 6 E., south of Ada, Pontotoc County, Okla.; Henryhouse formation (upper), Silurian.



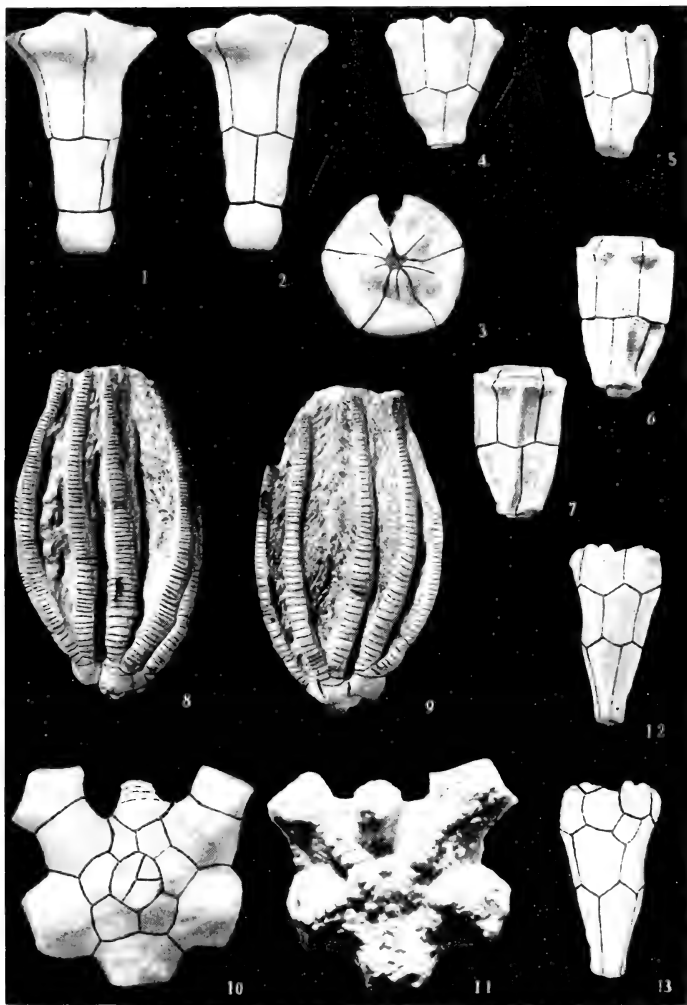

FIGS. 1-3.—Holotype of *Synbathocrinus antiquus*, n. sp., from posterior, anterior, and summit,  $\times 3.6$ . FIGS. 4-5.—Holotype of *Hexacrinites adamsis*, n. sp., from left anterior and posterior,  $\times 1.8$ . FIGS. 6-7.—Holotype of *Zophocrinus angulatus*, n. sp., side view of dorsal cup and opposite side,  $\times 3$ . FIGS. 8-9.—Holotype of *Allocrinus divergens*, n. sp., side view of crown and opposite side,  $\times 1.7$ . FIGS. 10-11.—Holotype of *Guartmoerinus pontotocensis*, n. sp., from base and summit,  $\times 5.8$ . FIGS. 12-13.—Holotype of *Bactrocrinites oklahomacensis*, n. sp., from right posterior and posterior,  $\times 1.5$ .

Genus *Bactrocrinites* Schnur, 1849*Bactrocrinites oklahomaensis*, n. sp.

Figs. 12, 13

Dorsal cup is very long, slender, expanding evenly from the columnar attachment. Five slender IBB form almost half the cup height. Five BB are normal hexagonal plates except for the posterior and right posterior RR which are truncated for the reception of the two anal plates. Five RR are relatively wide plates with small, outwardly directed arm articulating facets. R. post. R. is smaller than others and is extended above the normal cup height. Ant. R. is the largest plate of the circlet. RA is small, quadrangular and rests obliquely on the left shoulder of r. post. B and the right shoulder of post. B. Anal X is large, hexagonal and rests obliquely on post. B and RA to the right below. Arm articulating facets show no evidence of muscular fossae but have rather deep intermuscular notches which extend well into the body cavity.

*Measurements in mm.*—As follows:

Height of dorsal cup (anterior).....	22.3
Maximum width of cup.....	12.0
Height of IBB circlet.....	11.2
Maximum width of IBB circlet.....	7.8
Diameter of columnar scar.....	2.7

*Remarks.*—*B. oklahomaensis* has a more elongated calyx, especially as reflected by the IBB portion, than any other described species. It is the only representative of the genus reported from rocks of Silurian age.

*Holotype.*—Collected by the author. To be deposited in the U. S. National Museum.

*Occurrence and horizon.*—NW1/4NW1/4SW 1/4 sec. 4, T. 3 N., R. 6 E., south of Ada, Pontotoc County, Okla.; Henryhouse formation, Silurian.

Genus *Gnorimocrinus* Wachsmuth and Springer, 1880*Gnorimocrinus pontotocensis*, n. sp.

Figs. 10, 11

Dorsal cup shallowly expanded. IBB are three, almost entirely covered by the shallowly depressed, round columnar cicatrix. BB are five 6-sided plates with pentagonal outlines, except for post. B, which is strongly encroached upon by the hexagonal RA, and is extended inwardly toward the body cavity. RR are five rather elongated, pentagonal plates. Interradial areas are deeply impressed. Anal X is a large plate and is followed by a tubelike series of plates which curve inwardly. The entire body cavity

appears to be covered by tegmenal and minute ambulacral plates. Five rather large plates alternate with the RR, and that of the posterior carries a small node, which may mark a hydro-pore. First PBrBr are only preserved in the right and left posterior rays. The l. post. PBr is axillary and the r. post. PBr is nonaxillary. Both are rather short plates.

*Measurements in mm.*—As follows:

Height of dorsal cup.....	3.1
Maximum width of cup.....	7.0
Diameter of stem scar.....	1.7

*Remarks.*—Other described species normally disclose arm branching with the second primibrachials in all rays and the RA is quadrangular, not in contact with the IBB circlet. In *G. pontotocensis* the first PBr of the l. post. ramus is axillary and RA is hexagonal owing to contact with the IBB circlet.

*Holotype.*—Collected by A. R. Loeblich, Jr. Deposited in the U. S. National Museum.

*Occurrence and horizon.*—SW1/4NW1/4NW 1/4 sec. 33, T. 3 N., R. 6 E., Pontotoc County, Okla.; Henryhouse formation, Silurian.

Genus *Allocrinus* Wachsmuth and Springer, 1889*Allocrinus divergens*, n. sp.

Figs. 8, 9

Crown is elongate, expansive. Dorsal cup is proportionately quite small. The BB plates are displaced and are not sufficiently well preserved for accurate observation. Considering the attitude and structure of the RR, there is little likelihood that the base of the cup was particularly broad or invaginated, as is considered typical of the genus. Five RR are moderately large. The proximal portions are not curved under but the lateral sides are curved mildly inwardly and the depressions continue into the interbrachial region. Arm articulating facets do not fill the distal faces of RR and the junctures with PBrBr are not well defined. PBrBr are low, triangular shaped axillary plates, one to each ray. Succeeding SBrBr are low wide plates and are multiple pinnular.

One IBr is known to be present in one interray. The column is small and round. Tegmen is unknown.

*Measurements in mm.*—As follows:

Length of crown.....	37.2
Height of dorsal cup.....	2.8
Diameter of proximal columnal.....	1.8
Length of RR (to PBrBr).....	2.8
Maximum width of RR.....	3.9

*Remarks.*—In general appearance this species is obviously a member of *Allocrinus*, but certain

characteristics are not typical of the genus. In other known species there is a small quadrangular PBr in each ray followed by a larger pentagonal PBr which is axillary. The first PBr in each ray of *A. divergens* is low, triangular and axillary. The proximal extremities of RR are curved under to form part of a broad basal area in other species. *A. longidactylus* Springer (1926) displays arms, which are very similar to those of the present species except for the number of primibrachials.

**PALEONTOLOGY.**—Cribrotextularia, a new foraminiferal genus from the Eocene of Florida. ALFRED R. LOEBLICH, JR., and HELEN TAPPAN, U. S. National Museum.

In a search for topotype specimens of genotype species, for study in a generic revision of the Foraminifera, the writers found specimens of a textularian form with a cribrate aperture in middle Eocene material from Florida. Comparison with the types showed it to be the species *Textularia coryensis* Cole. The species was described by Cole (1941, p. 21) as having an "aperture broad, low, indistinct."

A thorough rewashing of topotype material including prolonged boiling, made possible the determination of the true apertural characters which were obscured in the holotype by adhering limy material. The cribrate aperture thus revealed is reminiscent of the upper Paleozoic foraminiferal genus *Cribrostomum* Möller, and affords an interesting example of convergence in development between these two stratigraphically distant genera.

Although Cushman (1948) defines *Cribrostomum* as "test free, biserial; wall finely arenaceous, thick, with an outer thin layer; apertures of the early stages textularian, later cribrate, on the terminal face of the chamber," he also noted that it "may be only a stage in the development of *Climacammina*." This latter genus he describes as "test free, early portion biserial, later uniserial; wall arenaceous, mostly of fine fragments but including coarser ones, cement calcareous; aperture in the biserial portion textularian, in the uniserial portion irregularly cribrate, terminal." Thus he distinguished these genera as *Cribrostomum* being wholly biserial and *Climacammina* biserial

*Holotype.*—Collected by Richard Alexander. To be deposited in the U. S. National Museum.

*Occurrence and horizon.*—NW1/4SW1/4 sec. 4, T. 2 N., R. 6 E., south of Ada, Pontotoc County, Okla.; Henryhouse formation (upper), Silurian.

#### REFERENCES

All cited references are to be found in Bassler and Moody, *Bibliographic and faunal index of Paleozoic Pelmatozoan Echinoderms*. Geol. Soc. Amer. Spec. Pap. 45. 1943.

to uniserial. Möller (1879) did not exclude bigenerine forms and in fact described *Cribrostomum bradyi*, *C. commune*, *C. elegans*, *C. gracile*, *C. pyriforme*, and *C. textulariforme*, of which only the first and last "species" were illustrated as completely biserial. Möller did not designate a genotype, but included four bigenerine forms to only two of the textularian forms. The genotype was selected by Cushman (1928, p. 120) as *Cribrostomum textulariforme*. However, all of Möller's species are surprisingly alike in size, ornamentation and other characters and it seems unlikely that six true "species" would occur in such a limited horizon, all very close in appearance and with similar geographic ranges. In fact, as was stated by Plummer (1945, p. 244) "The designated genotype [*C. textulariforme*] is without doubt the immature form of one of the five bifurmed species in the group of eight "species" recorded in the same paper with the description of *Cribrostomum*. *C. commune* Möller is recorded from the same localities as *C. textulariforme* and can well be the mature form of the species."

Other writers have also included bifurmed species under *Cribrostomum* including Lee and Chen (1930, pp. 96-102), Harlton (1927, p. 22) and Plummer (1945, p. 245). This genus might thus be considered synonymous with *Climacammina* H. B. Brady, 1873. However, they may be distinguished by apertural characters as was brought out by Plummer (1945, pp. 244, 245), who stated that "... symmetry in arrangement and in shape of the large and

comparatively few openings throughout the uniserial stage is a consistent feature that distinguishes the group represented by Brady's genotype of *Climacammina* from Möller's genotype of *Cribrostomum*."

*Cribrostomum* in the adult thus has a multiple aperture of irregularly shaped pores scattered over the terminal area with no definite pattern, whereas *Climacammina* has symmetrical pores both in shape and arrangement. A similar form, *Deckerella* Cushman and Waters, was described as like *Climacammina*, but with only two terminal pores. This "genus" is only a growth stage of *Climacammina* and the genotype species itself may have a multiple aperture of at least four openings.

Cushman regarded both *Cribrostomum* and *Climacammina* as having an arenaceous wall with calcareous cement. Galloway (1933, pp. 223, 224) stated that both are calcareous, consisting of an "inner, hyaline, fibrous or porous layer and outer darker,

very fine granular or structureless layer which is neither arenaceous nor composed of agglutinated particles but is partially a network of cryptocrystalline silica, the major portion being calcite; surface of test rough, giving an arenaceous appearance." Galloway used this type of wall structure as the basis for a new subfamily, the Palaeotextulariinae. Lee and Chen (1930, p. 100) in describing *Cribrostomum longissimoides* state "Wall composite, with a relatively thin and smooth inner layer and much thicker and coarser outer layer of arenaceous nature." Plummer (1945) corroborated these observations stating "The calcareous shell wall is almost wholly fibrous with an external coating of irregular calcareous particles or granules, so that the surface is pebbled, though composed of no adventitious matter." Plummer also noted that "the cribrate surface of chambers in the late biserial stage and throughout the uniserial stage is supported and strengthened by

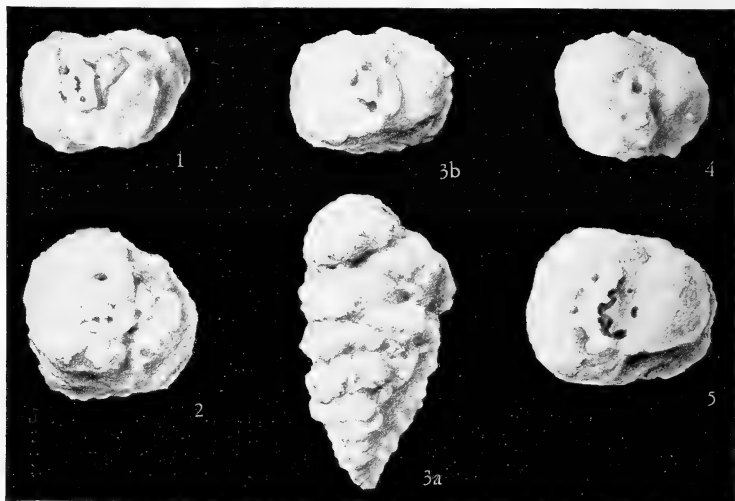

FIGS. 1-5.—*Cribrotextularia coryensis* (Cole): 1, Top view of hypotype (USNM P. 67a), with final chamber broken to show slit aperture of previous chamber and supplementary apertures; 2, 4, top views of additional hypotypes (USNM P. 67 b, c) showing multiple apertures; 3a, side view of hypotype (USNM P. 67d) showing biserial chamber arrangement; 3b, top view, showing ring of apertures; 5, top view of hypotype (USNM P. 67e) with broken final chamber with part of ring of apertures visible and also showing multiple apertures of preceding chamber where final chamber is broken away. (All figures  $\times 33$ .)

irregularly developed walls and pillars that tie the terminal wall to the last septum, thus making the chamber labyrinthic."

The following brief description summarizes the characters of the new genus:

Family TEXTULARIIDAE

*Cribrotetularia* Loeblich and Tappan, n. gen.

Genotype: *Textularia coryensis* Cole. Middle Eocene of Florida.

*Diagnosis*.—Test free, quadrate in section; chambers biserially arranged throughout; wall arenaceous, simple in construction, not labyrinthic; aperture in early stages consisting of an arch at the base of the last chamber and in addition a symmetrical series of pores, usually in a ring, on the face of the chamber, arched aperture partially closed in later chambers and represented by a series of openings at the base of the final chamber in addition to the terminal cribrate apertures.

*Remarks*.—The present genus differs from both *Climacammina* and *Cribrostomum* in being wholly biserial, and in lacking any uniserial development, in being quadrate rather than oval in section, in lacking surface ornamentation, in having a simple and distinctly arenaceous wall, and not a double-layered fibrous calcareous one, and in lacking any development of pillars supporting the terminal chamber as was found in *Cribrostomum* by Plummer. It further differs from *Cribrostomum* in having a ring of symmetrically arranged rounded pores as the cribrate aperture, rather than irregularly shaped and spaced openings, and in this respect is more like *Climacammina*. However, the cribrate aperture is visible only on the final chamber, while all the pores on earlier chambers are covered by the wall of the succeeding chamber. On biserial specimens of *Cribrostomum marblense* Plummer, the cribrate aperture is visible on both chambers of the last pair.

*Cribrotetularia coryensis* (Cole)

Figs. 1-5

*Textularia coryensis* Cole, Florida Geol. Surv. Bull. 19: 21, pl. 1, fig. 13. 1941.

Test free, large, robust, triangular in side view, quadrate in section; chambers numerous, biserially arranged, increasing gradually in height and breadth as added, slightly inflated; sutures distinct, depressed, nearly straight, slightly oblique; wall agglutinated, with distinct cal-

careous fragments in a granular ground mass, surface irregular; aperture in the early stages consisting of an elongate slit at the base of the final chamber, which becomes progressively closed in later chambers with the simultaneous development of a terminal cribrate aperture of about four or five regularly spaced openings, the complete slitlike aperture has not been observed on the final chamber of any specimen, although it can be seen in the penultimate chamber of one of the hypotypes (Fig. 1), the final chamber has only a few residual pores representing the slit aperture, and a better development of the terminal cribrate aperture.

Length of figured hypotype (Fig. 3) 1.77 mm, greatest breadth 0.94 mm, thickness 0.73 mm. Other specimens are from 1.51 to 2.29 mm in length.

*Types and occurrence*.—Holotype and unfigured paratypes (Florida Geological Survey collections, S-1533 and S-1533A) and unfigured hypotypes also in Florida Geological Survey Collections (S-3330), figured hypotypes (USNM P. 67, a-e) all from the middle Eocene at 1,360-1,370 feet in the Peninsular Oil and Refining Co. Cory No. 1, in sec. 6, T.55S., R. 34E., Monroe County, Fla.

*Acknowledgements*.—The writers are indebted to Dr. Herman Gunter, director of the Florida Geological Survey, for use of topotype material and also for the loan of Cole's type specimens. The illustrations are camera-lucida drawings made by Mrs. Sally D. Lee, scientific illustrator, Smithsonian Institution.

REFERENCES

- COLE, W. S. *Stratigraphic and paleontologic studies of wells in Florida*. Florida Geol. Surv. Geol. Bull. 19: 1-91, pls. 1-18. 1941.
- CUSHMAN, J. A. *Foraminifera, their classification and economic use*. Cushman Lab. Foram. Res. Spec. Publ. 1: 1-401. 1928.
- . *Foraminifera, their classification and economic use*, ed. 4: 1-605, pls. 1-55. 1948.
- HARLTON, B. H. *Some Pennsylvanian Foraminifera of the Glenn formation of southern Oklahoma*. Journ. Pal. 1: 15-27, pls. 1-5. 1927.
- LEE, J. S., CHEN, S., AND CHU, S. *The Huanglung limestone and its fauna*. Acad. Sinica, Nat. Res. Inst. Geol., Mem. 9. 1930.
- MÖLLER, V. *Die Foraminiferen des russischen Kohlenkalks*. Mém. Acad. Imp. Sci. St.-Petersbourg, sér. 7, 27: (5). 1879.
- PLUMMER, H. J. *Smaller Foraminifera in the Marble Falls, Smithwick, and lower Strawn strata around the Llano uplift in Texas*. Univ. Texas Publ. 4401: 209-271, pls. 15-17. 1945.

ZOOLOGY.—*Ammopemphix*, new name for the Recent foraminiferal genus *Urnula* Wiesner. ALFRED R. LOEBLICH, JR., U. S. National Museum.

The name *Urnula* proposed by Wiesner (Deutsche Südpolar-Exped. 20: Zool.: 82. 1931) for a Recent Antarctic foraminiferal genus is preoccupied by the protozoan *Urnula* Claparède and Lachmann (Ann.

Sci. Nat., Paris, Zool. ser. 4: 8: 235. 1857). The name *Ammopemphix* is here proposed to replace the name *Urnula* Wiesner. The genotype (type species) is *Urnula quadrupla* Wiesner, 1931.

ZOOLOGY.—A new Calyptrophora (Coelenterata: Octocorallia) from the Philippine Islands.<sup>1</sup> FREDERICK M. BAYER, U. S. National Museum.

Among the unidentified primnoïd octocorals of the U. S. National Museum which have been examined in connection with studies on the Gorgonacea of the Indo-Pacific region, there is a single branch of a remarkable species of *Calyptrophora*. Its zooids are so distinctly different in armature from those of any previously described species that I feel justified in describing it as new even without knowledge of the appearance of the entire colony.

It is with a deep sense of appreciation that I name this species in honor of Dr. Julia A. Gardner, of the U. S. Geological Survey.

#### Genus *Calyptrophora* Gray

*Calyptrophora* J. E. Gray, 1866, p. 25; Kükenthal, 1924, p. 317.

#### *Calyptrophora juliae*, n. sp.

*Diagnosis*.—Zooids about 1.75 mm high, facing upward, in whorls of 4-6; 15 whorls in 3 cm of axis length; both scale pairs inseparably fused in ring form; basal ring with two stout diverging spines 1.5 mm long; buccal ring margin with 2-4 short, triangular processes; operculars not lacinated apically; rind scales without external crests; tentacles with minute flat scales.

*Description*.—The type specimen is a single terminal branch about 12 cm long, which bears closely set whorls of distally directed zooids throughout its length except for the proximal 5 mm, where the axis is bare. The axis is distinctly flattened, at least in this branch, longitudinally grooved and of a metallic gold sheen with bright green iridescence. Fifteen zooid whorls (Fig. 1, *f*) occur in 3 cm of axial length; the apical

whorl contains four zooids, while those lower down on the branch ordinarily are made up of five or six. The zooids (Fig. 1, *e, k*) are surrounded by two pairs of body scales, basal and buccal, as is characteristic of the genus. The members of both sclerite pairs are completely united and inseparably fused to form a pair or rings which encircle the zooid body. The basal ring (Fig. 1, *h*) is unusually thick and heavy, and bears a single pair of strong, tapered, diverging spines. These are very stout and nearly round, and are longitudinally sculptured with fine, wavy striae which are minutely prickly, especially toward the tips of the spines. The spines are about 1.5 mm long (1.25-1.75 mm) and about 0.35 mm thick at the base. The body of the ring is externally finely granular, the granules so arranged as to form a closely reticulate pattern. The total length of the basal ring including the spines is about 2.75-3.00 mm. The buccal ring (Fig. 1, *g*) is stout but not so heavy as the basal. It expands somewhat distally, but is not flared, and there is only a very slight projecting margin which bears one or two pairs of short, triangular processes. The length of the buccal ring along the abaxial suture is about 1.25 mm; its diameter at the oral aperture about 1 mm. There is a well-developed operculum of eight roughly triangular scales 0.4 to 0.6 mm high (Fig. 1, *a-d*). Each bears a prominent longitudinal ridge on its inner face, and even the largest show no tendency toward lacination of the apex. The tentacles contain small, elongate, irregular-margined scales (Fig. 1, *i*) about 0.1 mm long. Ordinarily there is but a single pair of curved infrabasal plates lying between the basal scale ring and the plates of the coenenchyma, but one or both may be transversely divided into two short plates, so that there sometimes appears to be an extra infrabasal scale or pair of scales. The infrabasals

<sup>1</sup> Published by permission of the Secretary of the Smithsonian Institution.

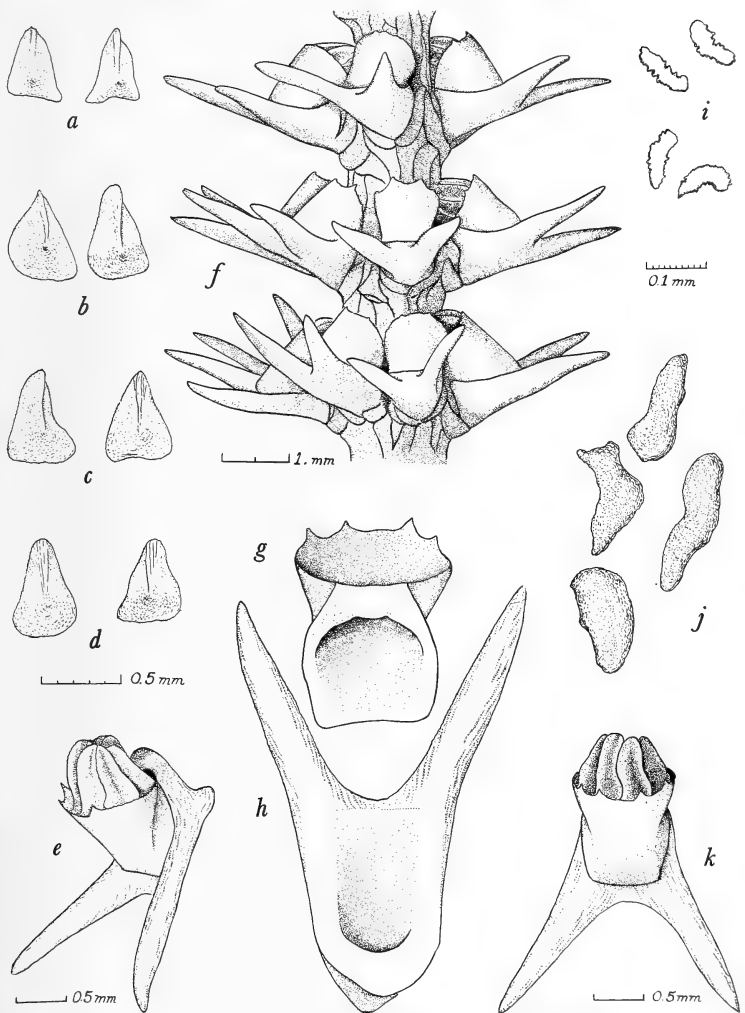

FIG. 1.—*Calyptrophora juliae*, n. sp.: a-d, Opercular scales; e, oblique view of single zooid; f, portion of branch with three whorls of zooids; g, buccal scale ring seen from adaxial side; h, basal scale ring from above; i, scales from the tentacles; j, plates from the coenenchyma; k, abaxial view of zooid. (Magnifications: 0.5 mm scale at a-d, g, h, j, k; 0.5 mm scales at e and k apply to those figures only; 1.0 mm scale at f, and 0.1 mm scale at i, apply to those figures only.)

form a semicircular collar which partially surrounds the base of the zooids. The rind sclerites (Fig. 1, j) are flat, irregular, granular plates without strong external keels or ridges. All of the large sclerites are translucent, milky white.

*Type*.—U.S.N.M. no. 49814. *Albatross* station 5119, Philippine Islands: Verde Island Passage, between Lubang Island and Cape Santiago, Luzon, (13° 45' 05" N., 120° 30' 30" E.) 394 fathoms, sand and green mud; January 21, 1908.

*Remarks*.—While the over-all character of branching is unknown, there is a possibility that the entire colony has the lyrate form which occurs in various species of *Calyptrophora* (cf. Kinoshita, 1908, pl. 4, figs. 33, 35; and Versluys, 1906, p. 143, fig. 178).

The armature of the zooids, while basically like that of *Calyptrophora japonica* Gray (1866, p. 25; Versluys 1906, p. 113), is quite unlike any other described form. The spines of the basal ring are relatively longer and much stouter than those of the type of *C. japonica* as described by Versluys. The zooids of *C. juliae* are stouter and larger than those of *C. clarki* Bayer 1951, and the marginal processes of the buccal ring are never so

strongly developed; the buccal ring of *C. juliae* bends adaxially more sharply than does that of *C. clarki*; and so far as I can determine, its opercular scales are never divided apically into lobes.

The close-set whorls of zooids, with their strongly projecting spines, give even this single branch a distinctive appearance, and the entire colony must have been one of striking elegance.

#### LITERATURE CITED

- BAYER, FREDERICK M. *Two new primnoid corals of the subfamily Calyptrophorinae (Coelenterata: Octocorallia)*. Journ. Washington Acad. Sci. **41**(1): 40-43, 2 figs. 1951.
- GRAY, JOHN EDWARD. *Description of two new forms of gorgonioid corals*. Proc. Zool. Soc. London 1866: 24-27, 2 figs. 1866.
- KINOSHITA, KUMAO. *Primnoidae von Japan*. Journ. Coll. Sci. Imp. Univ. Tokyo **23**(12): 1-74, 9 figs., 6 pls. 1908.
- KÜKENTHAL, WILLY. *Gorgonaria*. Das Tierreich **47**: xxviii + 478, 209 figs. Berlin and Leipzig, 1924.
- VERSLUYS, J. *Die Gorgoniden der Siboga Expedition. II, Die Primnoidae*. Siboga Exped. Monogr. **13a**: 1-187, 178 figs., 10 pls., chart. 1906.

ICHTHYOLOGY.—*Eight new fishes from the Gulf coast of the United States, with two new genera and notes on geographic distribution*. ISAAC GINSBURG, U. S. Fish and Wildlife Service. (Communicated by Ernest A. Lachner.)

In the course of my studies of the fishes of the Gulf of Mexico, eight species were found not to have been named previously. This conclusion was reached after a virtual revision of the species of their respective families that occur in the Gulf and adjacent waters. Only one of the species is based on a single specimen. The others are based on sufficient numbers to indicate that they are not uncommon. Three of them are common enough to enter the commercial fish catch at the present time. One offshore species apparently occurs in sufficient numbers to have market possibilities.

During an investigation of the southern species of commercial shrimps, the U. S. Fish and Wildlife Service, by means of the research boat *Pelican*, preserved and brought together a collection of fishes on the coast of our Southern States, which is of great value in the study of the ichthyological fauna of the Gulf and adjacent waters. It

is my privilege to be engaged in a study of this collection, and four of the species herein described were obtained by the *Pelican*.

Three of the species indicate a peculiarity of geographic distribution of the fish fauna of the Gulf, to which attention is called and which is discussed at a later point.

The photographs for Figs. 1-8 were made in the Smithsonian Photographic Laboratory.

#### Family SERRANIDAE

##### *Centropristes melanus*, n. sp.

##### GULF BLACK SEABASS

D X 11. A III 7. P 17-18. Sc 47-49.

Dorsal and anal spines and rays constant (in 12 specimens). Gill rakers on lower limb 10-14 with 1-4 tubercles, or 14-17 altogether; on upper limb gill rakers grade gradually into tubercles or the difference between the two kinds only moderately indicated, 7 or 8 altogether; total number of gill rakers and tubercles on both limbs 21-25.



Body elongate, moderately deep. Mouth terminal, lower jaw subequal to upper in front or slightly projecting. Maxillary ending under middle of eye or posterior margin of pupil, without supplemental bone; a broad, rather shallow elongate groove below upper maxillary edge, setting off an elongate, moderately depressed piece having somewhat the shape of a supplemental maxillary (as in *Epinephelus*), but without an evident suture. Teeth in jaws in bands of medium width, widest in upper jaw; side of lower jaw with only two rows of teeth; outer and inner teeth moderately enlarged; no canines; none of the teeth depressible to a marked extent. Opercle drawn out posteriorly to form a rather long, flexible flap; middle opercular spine well developed; lower spine moderate; upper spine not developed, in form of blunt, rounded protuberance. Preopercle not expanded; its transverse margin well serrate; lower margin rather sparsely serrate, the serrae covered by skin; serrae at angle slightly enlarged; interopercle and subopercle moderately serrate or smooth. Branchiostegal rays 7. Scalation on midback ceasing at moderate distance behind eye, its anterior boundary a nearly straight, transverse line; cheek and opercle scaled; interopercle sparsely scaled; patch of scales over cheek and opercle moderately or rather well separated from posterior scales; interorbital, snout, suborbital, maxillary and lower jaw naked; proximal part of caudal rather well scaled for a considerable distance, scaleless posteriorly; other fins scantily scaled near their base; all scales ctenoid (besides small scales on fins), except those on chest sometimes cycloid. Lateral line moderately rising anteriorly, running nearly parallel to contour of back and at some distance below it, making a slight curve at caudal peduncle; 4 or 5 longitudinal rows of complete scales between highest part of lateral line and midback, besides a row of incomplete scales; modified, channeled scales in lateral line moderately smaller than adjacent normal scales, not separated by latter or only slightly so. First three dorsal spines abruptly and nearly evenly or somewhat unevenly graduated; first and second usually about half as long as second and third, respectively; third spine only a little shorter than fourth and longest; thence very gradually decreasing in length to eighth; last two spines subequal to or slightly longer than the one immediately preceding; last spine moderately shorter than first ray, emargination between spinous and soft parts of dorsal moderate.

Second anal spine a little shorter and slightly stouter than third. Ventral about reaching anus or falling a little short, its outer angle a little in front of lower pectoral angle. Pectoral having its posterior margin nearly truncate, rounded at angles, more so below than above, ending nearly on same vertical as ventral or a little behind. Caudal asymmetrical, rounded for its greater and lower part, a moderate emargination above, the second branched ray from top moderately or slightly produced.

Measurements of four specimens 95–136 mm in standard length, and two, including the holotype, 177–206 mm, expressed as a percentage of the standard length, the ranges of the smaller specimens in parenthesis, as follows: Depth (33.0–38.5) 35–36, depth of peduncle (13.5–14.5) 13–13.5, head to end of flap (40–41.5) 41–44, maxillary (17–18.5) 20.5–21, snout (11.5–12.5) 12.5–13, eye (8.5–9.5) 8–9, interorbital (7–8.5) 7.5.

General ground color dark to nearly black; often with very faint traces of irregular, wide darker cross areas, separated by narrower, slightly lighter interspaces; scales with a lighter colored area on exposed part anteriorly, surrounded peripherally with dark pigment, presenting in gross appearance effect of beadlike longitudinal lines of light spots along rows of scales; no definite dark spot at posterior end of spinous dorsal base; a diffusely dusky area on inner side of opercle, at its upper, anterior part, but no well-defined spot on inner or outer surface of opercle; anal and ventral dark, sometimes edged with lighter color; pectoral uniformly very moderately dusky or nearly pigmentless; dorsal with obliquely lengthwise rows of diffuse light spots; caudal with very faint spots, almost uniformly dusky or dark.

*Holotype*.—C.N.H.M. no. 33719. Newport, near Wakulla, Fla.; November 10, 1937; Fred Ladd; 270 mm.

*Paratypes*.—C.N.H.M. nos. 33717–8, 33721–3; same data as holotype. Pensacola, Fla.; S. Stearns

TABLE 1.—FREQUENCY DISTRIBUTION OF THE NUMBER OF GILL RAKERS AND PECTORAL RAYS OF *CENTROPRISTES MELANUS* AND *C. STRIATUS*

Species	Total gill rakers and tubercles on both limbs					Gill rakers and tubercles on lower limb only					Pectoral rays						
	21	22	23	24	25	26	27	28	14	15	16	17	18	19	20		
<i>melanus</i> .....	1	4	6	1	1				1	5	5	1			8	5	
<i>striatus</i> .....					8	6	15	1			1	13	14	2	8	23	1

(U.S.N.M. no. 21483). St. Marks, Fla.; B.C. Marshal; August 1931 (92232). Aucilla, Fla.; *Fish Hawk* station 7147; 3 fathoms; November 6, 1901 (73009). Cedar Keys, Fla.; C. R. Aschmeier; March 3, 1938 (106990). Total 11 paratypes 48–270 mm.

*Remarks.*—This species differs from the other two species of *Centropristes* occurring in the Gulf, *ocyurus* and *philadelphicus*, in having fewer scales and more gill rakers (scales 53–57 and total number of gill rakers and tubercles on both limbs 18–21 in the latter two species) and in not having the caudal biconcave, besides other minor differences. It is very close to the Atlantic *C. striatus*. As shown in Table 1, *melanus* diverges from *striatus* in the combined gill raker and tubercle count, that on the lower limb of the first gill arch and also in the total of both limbs, to a degree that is of species magnitude or very nearly so. A high divergence of the pectoral count is also indicated, but of lesser magnitude. Also, in *striatus* the emargination on the upper part of the caudal is generally more pronounced, and the second branched ray from the top is usually much more prolonged. The data for *striatus* given in Table 1 are based on specimens ranging from Woods Hole, Mass., to New Smyrna, Fla.

Three species of *Centropristes* occur in the Gulf, *melanus*, *philadelphicus*, and *ocyurus*. The species here described is the counterpart of *striatus* from the Atlantic. By their long isolation, the Gulf and Atlantic populations have diverged morphologically to a degree of species magnitude, or at least to a degree that is at the borderline of species and subspecies. I have also compared the Gulf populations of *philadelphicus* and *ocyurus* with their corresponding populations in the Atlantic and find some differences; but those differences are of low degrees, below the subspecies level. It is reasonable to assume that all the populations have been isolated by the peninsula of Florida equally in point of time. It is interesting then to note that in the same genus there is an evident wide difference in the tempo of population divergence.

Weed (1937) treats of the species of *Centropristes* and describes a new species, *springeri*, from the Gulf. His treatment in some respects is unsatisfactory. He does not adequately describe the well-marked difference in the shape of the caudal between *striatus* and *philadelphicus*, which evidently constituted the main character on which Gill established a distinct genus, *Trilo-*

*burus*, based on *philadelphicus*; but the caudals of his specimens might have been damaged. He further states that the scale count is the same in all the species; whereas I found it to be a good character for separating *striatus* and *melanus* from *ocyurus* and *philadelphicus*. The latter discrepancy might be due to differences of method; Weed counted the scales in the lateral line, while my counts are of the number of oblique rows above the lateral line. I have reexamined the three specimens on which Weed based his *springeri* and find that they belong to the same species as the holotype of *ocyurus*, and consequently these two names are synonymous, *ocyurus* having priority.

#### *Serraniculus*, n. g.

*Genotype.*—*Serraniculus pumilio*, n. sp.

Body elongate, rather spindle-shaped. Mouth subsuperior, the lower jaw moderately projecting. No supplemental maxillary. Upper jaw without notch. Teeth in jaws in rather wide bands; in two rows on side of lower jaw; outer teeth in both jaws and inner teeth in lower jaw enlarged, a few moderately enlarged inner teeth at symphysis of upper jaw also; inner teeth on side of lower jaw largest, 3 or 4 of those teeth moderately larger than adjacent ones but hardly large enough to be designated canine; vomer and palatines with teeth; tongue toothless. Lower two opercular spines well developed; upper spine short and pointed or a rounded, slight protuberance. Transverse margin of preopercle serrate, lower margin smooth. Branchiostegal rays 6. Gill rakers short, few. End of posttemporal not covered by skin, exposed in form of rather heavy scale (often referred to as "axillary scale"). Body entirely covered with ctenoid scales, including chest and pectoral base; opercle and cheek scaled; interopercle scaled for a variable distance at its posterior end only; dorsal aspect of occiput interorbital, snout, suborbital, maxillary and lower jaw scaleless. Lateral line rising moderately in front and making a slight curve at caudal peduncle; three longitudinal rows of complete scales between highest part of lateral line and midback, besides a row of incomplete scales; modified, channeled scales in lateral line notably smaller than adjacent normal scales and separated by them. All dorsal spines pungent and of normal length. Caudal having its distal margin very slightly rounded.

This genus is near *Centropristes*, structurally and in general appearance. *Serraniculus* differs

in constantly having six branchiostegal rays, instead of seven. The caudal shape is as in the young of *Centropristes* and markedly unlike that of the adults. That is, *Serraniculus* retains the juvenile caudal of *Centropristes* also in the adult stage. *Serraniculus* differs as well from all other known serranid genera on the Atlantic coast of

North America in having six branchiostegal rays. As errors in the treatment of this character have entered the literature, which have been copied and repeated by successive authors, the pertinent literature of the species concerned is here briefly reviewed in connection with the establishment of *Serraniculus*.

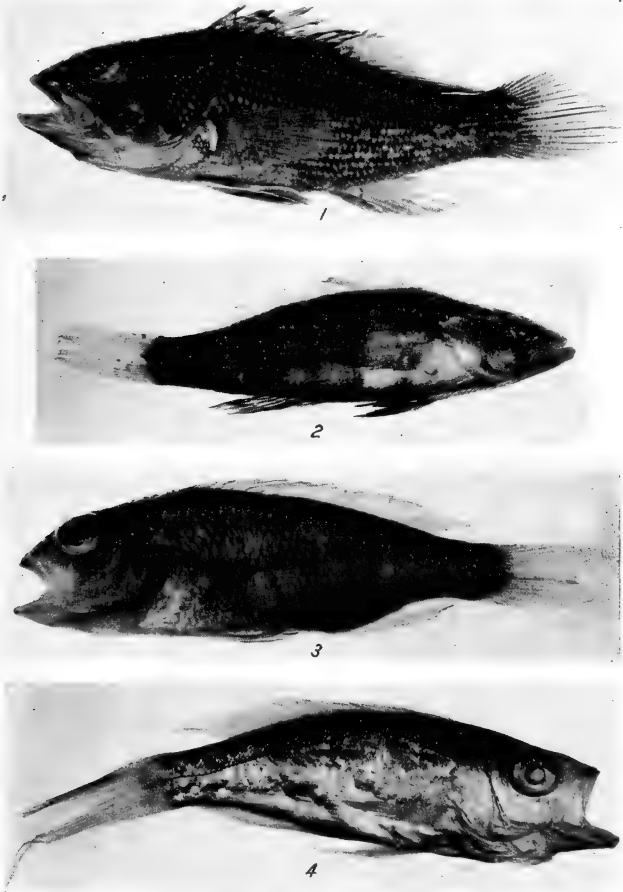

FIGS. 1-4.—1, *Centropristes melanus*, n. sp., a paratype, 122 mm; 2, *Serraniculus pumilio*, n. gen. and sp., holotype; 3, *Paracentropristes pomospilus*, n. sp., holotype; 4, *Anthiasicus leptus*, n. gen. and sp., holotype.

Jordan and Evermann (1896, pp. 1218-1219) erroneously place *Centropriestes subligarius* Cope and *C. dispilurus* Günther in *Dules* Cuvier on the assumption that they have six branchiostegal rays. However, in 21 and 5 specimens of those two species, respectively, which I examined in the National Museum, the branchiostegal rays are constantly seven. Also, in those two species the dorsal spines are normal in length and pungency, none being notably produced. *Dules*, on the other hand, is a monotypic genus characterized by a combination of two salient characters, the presence of only six branchiostegal rays and the striking whiplike prolongation and flexibility of the third dorsal spine. These two characters hold in all 14 specimens of what is presumably *Dules auriga* Cuvier, which I examined in the National Museum from the general region of Río de la Plata, South America. *Serraniculus* has six branchiostegal rays like *Dules*; but otherwise the two genera seem only remotely related. *Dules* differs from *Serraniculus*, apart from the structure of the third dorsal spine, in having a notably deeper body, a long, somewhat pointed snout, a deeper and shorter caudal peduncle and more numerous dorsal rays, the latter often being a generic character in the family Serranidae.

Boulenger (1895, p. 287) erroneously placed *subligarius* and *dispilurus* as synonyms of *Dules auriga*, claiming that the former two names represent females and the latter name males of the same species. Judged by his listed specimens, Boulenger evidently examined only three specimens, one *auriga*, two *dispilurus* and none of *subligarius*, and based his sex determination and conclusion on these three specimens. In reality, these three names represent three separate species which are very readily distinguishable, much more so than some other closely related serranid species.

Fowler (1907, p. 265) establishes a new subgenus, *Callidulus*, under *Dules* (which he re-names *Eudulus*), based on *subligarius* as the genotype, again on the erroneous assumption that *subligarius* has six branchiostegal rays. The new name *Callidulus* (as well as *Eudulus*) is an unnecessary addition to the nomenclature, as *subligarius* is near enough to *Serranus scriba* Linnaeus to be placed in the same genus; while *scriba* is the genotype of *Serranellus* Jordan (in Jordan and Eigenmann, 1890, p. 399). Therefore, *subligarius*, and the closely related *dispilurus*, should be placed in the genus *Serranell-*

*lus*. On a revision of the family, it might be found advantageous to treat *Serranellus* as a subgenus of *Serranus*, as it was treated by Jordan and Eigenmann.

The untenable placement of *subligarius* and *dispilurus* by Jordan and Evermann and their erroneous treatment by Boulenger are perhaps due, in part, to the three species having two general features in common: (1) the shape is rather unusual and similar in all three species, and (2) they also have a light yellowish color more or less developed in the abdominal region. Either these features represent parallel developments in *Dules auriga* or else the latter is derived from *Serranellus* but has become modified to such an extent as to represent a divergence of genus magnitude.

The five specimens of *dispilurus* which I examined, as noted above, so labeled in the National Museum collection, evidently correctly, are from Jamaica and Puerto Rico. Jordan and Eigenmann (1890, p. 405) venture the opinion that *dispilurus* is a synonym of *Dules flaviventris*, which Cuvier and Valenciennes (1829, p. 113) originally described from Brazil. Judged by the brief description of the latter species, the suggested synonymy seems well advised; but I have no specimens from Brazil to verify it. Should that synonymy prove to be correct, then Cuvier and Valenciennes were also in error in placing *flaviventris* in *Dules*, as they based that genus, first established in the publication cited above, on the presence of six branchiostegal rays.

The first branchiostegal ray in serranids is often short, thin, and closely approximated to the second ray, and it might be overlooked unless particular care is exercised. This perhaps explains some of these errors that entered the literature.

#### *Serraniculus pumilio*, n. sp.

D X (10) 11. A III 7. P 14-15. Sc 44-46. GR 5-7.

Dorsal rays normally 11 (in 20), infrequently 10 (in 1); dorsal and anal spines and anal rays constant (in 21). Pectoral rays 14 (in 12) or 15 (in 9). Gill rakers on lower limb 5-7 with 1-4 tubercles, or 8-11 altogether; upper limb with 0-3 gill rakers and 0-4 tubercles, or 3-5 altogether; total number of gill rakers and tubercles on both limbs of the first gill arch 11-14. Body and caudal peduncle of medium depth; upper profile rising moderately from snout to dorsal origin; peduncle deeper than eye diameter; dis-

tance from a median point under end of dorsal to caudal base, greater than eye diameter; maxillary ending under anterior margin of pupil or slightly behind. First three dorsal spines rapidly and almost evenly graduated; the first a little less than one-half as long as second; second a little more than one-half as long as third; third to fifth subequal or slightly increasing in length, thence gradually decreasing to ninth; tenth spine a little longer than ninth and moderately shorter than first ray, emargination between spinous and soft parts of dorsal moderate. Ventral rather short, falling short of anus, its end at a more anterior point than that of pectoral, its outer angle slightly in front of lower pectoral angle, its spine about one-half as long as rays. Distal margin of upper two-thirds of pectoral a well-inclined line, its lower angle rounded.

Diffusely and irregularly cross-banded; with four diffuse, dark or dusky bands, the first under dorsal origin, the last at caudal base; anterior three bands broader than interspaces, last band comparatively narrow, preceded by broad lighter interspace over greater part of caudal peduncle; the bands without definite boundaries, the dark shade more or less encroaching and becoming diffuse on interspaces; sometimes bands and interspaces hardly distinguishable, except light interspace on peduncle; interspaces often with a silvery tinge, the interspace between first and second bands often especially prominent as a transverse silvery band on lower two-thirds of body, under middle of spinous dorsal; a series of small dark spots on upper profile often distinguishable, 4 or 5 at dorsal base, the first at base of last spine, the fourth or fifth at end of dorsal somewhat more prominent, one at end of peduncle and one or two on upper margin of caudal near its base; a characteristic, yellowish, rounded spot directly behind last dark band, at its lower half; sometimes a similar spot, smaller and not as well marked, also at its upper half; a light streak along course of lateral line with dark very small spots placed at somewhat irregular intervals; spinous dorsal usually with a large dark blotch a little below its distal margin, between seventh and ninth spines, often hardly perceptible; anterior margin of dorsal often with three dark dots, one above the other; ventral and anal almost uniformly dark to black; other fins usually rather sparsely pigmented, without rows of well marked spots, except some irregular shadings, and caudal and lower pectoral edge broadly margined with dusky or blackish.

Measurements (expressed as a percentage of the standard length) of three specimens 56–59 mm, including the holotype, and 3, 70–80 mm, those of the smaller specimens in parenthesis: caudal (25–26) 24–25, ventral (24–25) 22–23, pectoral (26–28.5) 26.5–28.5, depth (27–29.5) 29.5–31, depth of peduncle (12.5–13.5) 13–13.5, head (34.5–35) 35.5–36, maxillary (13–14.5) 14–15, snout (8.5–9.5) 9–10.5, eye (9.5–10) 8.5–9.5, interorbital (5–6) 5.5–6.5.

*Holotype*.—U. S. N. M. no. 133791. *Fish Hawk* station 7177; lat. 29° 05' N., long. 83° 22' 30" W.; off Cedar Keys, Fla.; 5½ fathoms; November 27, 1901; 56 mm.

*Paratypes*.—Off Mobile Bay, Ala. (U.S.N.M. nos. 101521, 144164–5). Georgia (149971). Off Cape Lookout, N. C. (131015). Texas; Texas Game, Fish and Oyster Commission (C.N.H.M.). Also, the following *Pelican* stations: Off Cape Canaveral (station 208–2) and St. Augustine (208–8), Fla.; off St. Andrews Sound (177–12), St. Simon Island (178–7) and Ossabaw Island (180–7), Ga.; off Head Island (182–8), St. Helena Sound (195–2) and Edisto Island (194–13), S. C. Total paratypes 20, taken in 6–32 fathoms, 33–80 mm.

*Remarks*.—The abdominal cavity of one 63-mm specimen was exposed to examine the gonads. They were found to contain ripe eggs. The structure of the gonads does not appear to be uniform in gross appearance. Interspersed with the masses of ripe roe are areas of tissue which have the gross appearance of milt. It seems probable, therefore, that this species is hermaphroditic like some other serranids.

This is the smallest American serranid discovered so far. It is readily distinguished by its generic and specific characters. Its relationship is discussed above under the account of the genus.

***Paracentropistes pomospilus*, n. sp.**

*Priónodes atrobranchus* Longley (not Cuvier and Valenciennes), Carnegie Inst. Washington Publ. 535:106. 1941 (Tortugas).

D X 12. A III 7. P 14–17. Sc 46–48. GR 9–11.

Dorsal and anal spines and rays constant (in 26 specimens). Pectoral rays normally 16 (only 4 variants in 57 specimens, 14 and 15 in one each, and 17 in 2). Gill rakers on lower limb 9–11, with 1–3 tubercles, or 10–13 in combined number; upper limb with 6 or 7 gill rakers and tubercles combined; total combined number of gill rakers

and tubercles on both limbs 17–20. Rather spindle-shaped, depth medium; depth of caudal peduncle somewhat greater than eye diameter. Snout subequal to or slightly shorter than eye. Mouth terminal, lower jaw subequal to upper or slightly projecting. Maxillary without supplemental bone, ending approximately under middle of eye. Teeth small, in narrow bands, widest in upper jaw, in two rows on side of lower jaw; upper jaw having outer teeth and a few inner teeth at symphysis larger than others; lower jaw having a few anterior outer teeth and all teeth in inner row enlarged; some inner teeth on middle of side of lower jaw larger than all others, but not large enough to be designated canine. Opercular spines poorly developed, short, stubby or slightly pointed. Preopercle serrate; serrae on lower margin stronger than those on transverse edge, except without serrae anteriorly for a third the distance or less. Scalation on antedorsal area extending to eye and continued on interorbital space approximately to opposite posterior margin of pupil; cheek, opercle, and interopercle completely scaled; anterior part of interorbital, snout, suborbital, maxillary, and lower jaw scaleless; 3 or 4 rows of complete scales between highest part of lateral line and midback; modified, channeled scales in lateral line notably small, widely separated by adjacent normal scales. First three dorsal spines nearly evenly graduated, the second about two-thirds as long as third; fifth or sixth spine longest or the two subequal, the length very gradually decreasing to third and last spines; first ray moderately longer than last spine, emargination between spinous and soft parts of dorsal slight. Second anal spine shorter and slightly stouter than third. Ventral pointed, reaching anus or a little short. Pectoral having distal margin of its upper two-thirds in a moderately inclined line. Caudal moderately and asymmetrically lunate, the upper lobe longer.

Measurements of four specimens 114–120 mm, including the type: Caudal (upper lobe) 25.7–31.0, ventral 27.0–29.5, pectoral 29.0–32.5, depth 31–35, depth of peduncle 12.5–14.0, head 34.5–37.5, maxillary 16.0–17.5, snout 9.0–10.5, eye 11.0–11.5, interorbital 5.5–7.0.

General color a nearly uniform light brownish or yellowish; sometimes very faint indication of dusky rather narrow cross bands, in an occasional specimen a somewhat obliquely placed cross band on body under base of eighth to ninth spine fairly marked; a lengthwise row of small, light yellowish spots, subtriangular or irregular, on

body behind head, a little above pectoral base, ending near end of pectoral, discernible only in the smaller specimens having the scalation nearly intact, imperceptible in the majority of specimens; some specimens with trace of a narrow black margin on anal and caudal; belly with a silvery tinge, better marked on chest; upper part of opercle with a large black or dusky area on inner surface, visible externally as a dark spot, often divided into two spots; no dorsal spot or other color marks.

*Holotype*.—U. S. N. M. no. 151883. *Pelican* station 108—1; lat. 28° 03' 30" N., long. 95° 41' 30" W.; off St. Joseph Island, Tex.; 26 fathoms; January 23, 1938; 120 mm.

*Paratypes*.—Three specimens obtained with the holotype; 29 other specimens collected by the *Pelican* at 19 other stations off the following localities: Padre Island and Corpus Christi, Tex.; Atchafalaya Bay, Grand Isle, and Mississippi Delta, La. Also, specimens in the National Museum taken off Dauphin Island, Ala., and Tortugas, Fla. Total number of paratypes 56, 75–133 mm. Depth records for these lots range 20–90 fathoms.

*Remarks*.—This species has been compared with the Mediterranean (*Labrus*) *Paracentropistes hepatus* (Linnaeus), the genotype of *Paracentropistes* Klunzinger. The Mediterranean species differs in having the scales 52–57, the interorbital nearly all scaled and the caudal very moderately emarginate. However, the two species are similar to a sufficient extent to be placed in the same genus. Among American species *pomospilus* is related to (*Serranus*) *Paracentropistes notospilus* (Longley). The two American species differ in a number of characters, the most striking of which are: the very poorly developed opercular spines of *pomospilus*, its deeper caudal peduncle, the lack of a dorsal spot and the presence of an inner opercular spot.

Longley refers specimens of this species to *Centropistes atrobranchus* Cuvier and Valenciennes. However, these authors (1829, p. 45), state that their species has a large black spot on the dorsal. Jordan (1887, p. 532) and Boulenger (1895, p. 289), both of whom examined and described the type specimen and placed the species under *Serranus*, state that it has a "jet black" and "inky black" blotch on the dorsal. In contrast, the 33 specimens recently preserved by the *Pelican* do not show a trace of such a spot, and this also holds for the other 24 specimens examined; while the presence or absence of a

dorsal spot is often a good specific character in serranid species. Moreover, judged by Boulenger's description there is another, structural difference. He states of the type of *atrobranchus*: "preopercle finely serrated, the serrae coarser at the angle, obsolete on the lower border . . .;" while in our specimens the serrae on the posterior two-thirds of the lower border, are well developed and as coarse as at the angle. It is evident that the species here described is not the same as Cuvier and Valenciennes's *C. atrobranchus*.

#### *Anthiasicus*, n. g.

*Genotype*.—*Anthiasicus leptus*, n. sp.

Body comparatively slender. Mouth superior. Supplemental maxillary absent. Upper jaw with a moderate notch at symphysis. Teeth in jaws in narrow bands, except in a single row on side of lower jaw; outer teeth very moderately enlarged; both jaws with two small canines in front and two inner canines; a caninoid on side of lower jaw; vomer and palatines with teeth; tongue toothless. Opercular spines poorly developed; the two lower ones short, obtuse; the upper not developed, a mere rounded protuberance. Transverse margin of preopercle rather well serrate; serrae on lower margin sparse; one serra at angle of preopercle rather large, subtriangular; interopercle and subopercle with a smooth edge. Gill rakers long, numerous. Branchiostegal rays seven. End of posttemporal not covered by skin, exposed in form of rather heavy scale. Scales comparatively numerous; anterior boundary of scalation a nearly straight transverse line at posterior margin of eye; interopercle scaled; interorbital, snout, suborbital, maxillary and lower jaw scaleless. Lateral line placed at a considerable distance below dorsal contour, five longitudinal rows of complete scales between highest part of lateral line and midback, besides two rows of smaller scales at dorsal base; modified, channeled scales in lateral line moderately smaller than adjacent normal scales and moderately separated by them. All dorsal spines pungent and of normal length. Pectoral pointed. Caudal deeply lunate, the lobes filamentous, nearly half as long as standard length.

*Anthiasicus* is evidently allied to the group of serranid genera which is partly characterized by having numerous rather long gill rakers, in addition to other characters. As compared with its near relatives in that group it differs from *Pronotogrammus* in the low position of lateral line and the relatively small scales. From *Hemanthias*,

it differs in having the third dorsal spine of normal length and pungency, not greatly prolonged and flexible, and in the deeply lunate caudal. From *Ocyanthias* it differs in the low position of the lateral line, the absence of teeth on the tongue, and the small scales. From *Anthias* it differs in not having the anterior part of the head scaled, in the notably shorter third dorsal spine, in the small scales, and in not having the ventrals greatly prolonged. The body is notably slenderer than in any of those genera.

#### *Anthiasicus leptus*, n. sp.

D X 14. A III 8. P 19. Sc 78. GR 10-26.

Eye rather large, subequal to snout, a little less than peduncular depth, about three times in head. Maxillary ending under anterior margin of pupil. First three dorsal spines nearly evenly and rapidly graduated, the first two-thirds as long as second, third moderately shorter than fourth and longest, thence gradually and slowly decreasing in length to last; last spine about three-fifths as long as first ray, emargination between spinous and soft parts of dorsal rather well developed; dorsal spines with very short filaments or tabs. Second anal spine moderately shorter and stouter than third. Ventral somewhat filamentous reaching a little past anal origin, its outer angle under lower pectoral angle. Pectoral reaching a vertical through vent. Color nearly uniform, golden above shading to silvery below; fins straw yellow; no distinctive color marks.

Measurements (expressed as a percentage of standard length). Standard length 108 mm; caudal upper lobe 48.5, lower lobe 46.5; ventral 28.5; pectoral 23.5; depth 31; depth of peduncle 13.5; head 36; maxillary 16.5; snout 11; eye 12; interorbital 8.5.

*Holotype*.—U. S. N. M. no. 134189; *Albatross station* 2378; lat. 29° 14'30" N., long. 88° 09' 30" W.; off Dauphin Island, Ala.; 68 fathoms; February 11, 1885; 160 mm; the only specimen examined.

The relationship of this species is discussed above under the genus. It is easily distinguished from all known Gulf serranids by the combination of its generic and specific characters, especially its fin ray, scale and gill raker counts.

#### Family LUTIANIDAE

#### *Pristipomoides andersoni*, n. sp.

*Pristipomoides macrothalmus* Hildebrand (not Müller and Troschel), Carnegie Inst. Washington Publ. 535:120. 1941.

D X (10) 11. A III 8. P 14-16. Sc 49-53. GR 16-17.

Dorsal rays normally 11 (in 36), infrequently 10 (in 1). Dorsal and anal spines and anal rays constant (in 38). Pectoral rays modally 16 (in 20), nearly as often 15 (in 16), sometimes 14 (in 2). Gill rakers on lower limb 16 or 17 with 0-2 tubercles in 24 specimens 100-240 mm, 16-18 with 0 or 1 tubercle in 14 specimens 44-95 mm, the total number of gill rakers and tubercles in both size groups 16-18; upper limb with 7-10 gill rakers, the 2-4 near angle of arch longer and nearly evenly graduated, the upper ones more or less abruptly short, the uppermost one sometimes tubercle-like; combined number of gill rakers and tubercles on both limbs, at all sizes, 24-28. Body rather deep, well compressed, somewhat spindle-shaped, ventral curvature only moderately less than dorsal. Snout rather short, blunt, subequal to or a little longer than large eye. Interorbital flat and broad, only a little narrower than eye diameter. Mouth well inclined, terminal, lower jaw only slightly projecting. Suborbital moderately wide. Maxillary ending under anterior margin of pupil or a little behind. Teeth on jaws, vomer and palatines small, in narrow bands, except outer and inner teeth in jaws and inner teeth on vomer more or less enlarged; upper jaw having one or two outer teeth near to and on both sides of symphysis large, caninoid, the other outer teeth smaller and gradually decreasing in size posteriorly; vomerine band of teeth somewhat in form of an arch with a shallow concavity posteriorly and crowned by a blunt apex anteriorly, without a backward extension on the shaft; no teeth on tongue. Opercle having a moderate spinous projection in a line with lower margin of eye, another projection at some distance above it blunt, broadly rounded. Preopercle without or with a very slight emargination on vertical edge, its horizontal edge serrate nearly all the way forward. Interorbital scaleless, boundary of scalation on midback opposite posterior margin of eye or slightly behind; an oblique band of scales on nape over cheek and opercle, well separated from rest of scales; greater part of interopercle scaled with 2-3 rows of scales; lengthwise rows of scales above lateral line parallel to it; dorsal and anal scaleless. Dorsal spines rather slender, first three very unevenly graduated, the first about half as long as second, the second only a little shorter than third, the last subequal to second; first dorsal ray very moderately longer than last spine, soft and spinous parts of dorsal

nearly continuous. Anal spines very moderately stout, the first about half as long as second, the second a little shorter than third. Last dorsal and anal ray longer than preceding rays. Ventral about reaching anus. Pectoral about reaching a vertical through base of first anal spine. Caudal deeply lunate, the upper lobe somewhat longer.

Measurements of two specimens 178-216 mm, including the type and two specimens 81-94 mm, those of the smaller specimens in parenthesis: caudal (upper lobe) 33.5-35.0 (30.0-32.5), ventral 26.0-26.5 (24.5), pectoral 31-32 (30.0-31.5), depth 37.0-40.5 (36-39), depth of peduncle 11.5 (12), head 35-38 (37.5-38.5), maxillary 16.0-16.5 (16-17), snout 11.5-12.5 (10.5-11.5), eye 10.5-11.0 (12-13), interorbital 9.5-11.5 (10.5-11.0).

General color of preserved specimens straw yellow, often with a slight reddish tinge; lower half often partly or almost wholly with a silvery tinge; often with a few very small, rounded or elongate, dark spots on lateral line spaced at irregular intervals or bunched close together, sometimes similar spots in oblique row on nape; no other distinctive color marks; fins plain yellowish. In life the species is of a prevailing pink color.

*Holotype*.—U. S. N. M. no. 151882. *Pelican* station 40; lat. 27° 24' 30" N., long. 96° 13' W.; off Padre Island, Tex.; 90 fathoms; 216 mm.

*Paratypes*.—Two specimens obtained with the holotype; 27 other specimens collected by the *Pelican* at 17 stations off the following localities: Padre Island, Corpus Christi, and St. Joseph Island, Tex.; Marsh Island and Atchafalaya Bay, La.; Horn and Petit Bois Islands, Miss.; Perdido Bay and Cape San Blas, Fla. Also, specimens in the National Museum taken at Tortugas, Fla., and off Dauphin Island, Ala. Altogether 37 paratypes 44-263 mm. Depth records, available for all except two lots, range 13-95 fathoms.

This species differs from the West Indian (*Centropristes*) *Pristipomoides macrophthalmus* (Müller and Troschel) in having more gill rakers and fewer scales. In three specimens of *macrophthalmus* from Cuba, 200-350 mm, the gill rakers on the lower limb are 11-12 and 2-4 tubercles or 13-16 altogether; on upper limb 6 or 7 gill rakers and tubercles combined; total number of gill rakers and tubercles on both limbs 20-22. This compares with a total count of 24-28 in 38 specimens of *andersoni* given above. The scale count in the Cuban specimens is 55-57 as compared with 49-53 for the 38 specimens of *andersoni*.



It is a pleasure to name this apparently common, offshore snapper after William W. Anderson, who, while carrying out an investigation of the species of commercial shrimp on the U. S. Fish and Wildlife research boat *Pelican*, inestimably served the science of ichthyology by industriously saving, preserving, and assembling as a unit a very valuable collection of fishes from off the Gulf and Atlantic coasts of our Southern States.

Family SPARIDAE

*Pagrus sedecim*, n. sp.

D XII 9-11. A III 8. P (15) 16. Sc 56-59. GR 9-11.

Dorsal and anal spines and anal rays constant (in 16). Dorsal rays usually 10 (in 14), sometimes 9 (in a specimen from North Carolina) or 11 (in a specimen from Brazil). Pectoral rays normally 16, sometimes 15 (16 on both sides in 14, 15 on both sides in one, 15 on one side and 16 on the other in one, both variants from the Carolinas). Upper limb of outer gill arch with 6 or 7 gill rakers; lower limb with 9-11 including one tubercle; total number on both limbs 15-17. Moderately deep (for a sparid); anterior profile rising steeply and making a smooth curve to dorsal origin; ventral profile nearly horizontal from head to anal origin. Snout long; preorbital broad; eye rather large. Mouth of medium extent, nearly horizontal, sub-terminal, lower jaw slightly included. Maxillary reaching a vertical through anterior margin of eye in the smaller specimens, a little short of that in the larger. Anterior part of jaws with a short outer row of strong, stout, nearly conical teeth, large enough to be designated canine, usually 4 teeth in upper jaw and 6 in lower, the middle two teeth in lower jaw much smaller than others; side of jaws with two rows of very stout, short teeth, anterior teeth in outer row subconical, rather pointed, changing to molars posteriorly, inner row shorter, the teeth all molar; an elongate patch of smaller teeth on both sides of midline behind outer anterior teeth, anterior teeth in patch rather conical and pointed becoming stouter and changing to small molars posteriorly; the patch of smaller teeth overlapping the two outer side rows of large teeth. Greater part of interorbital scaled, anterior boundary of scales curving to a point opposite anterior margin of eye; band of scales on cheek moderate, tapering upward. First four dorsal spines unevenly graduated, first nearly two-thirds as long as second; second and third about four-fifths as

long as third and fourth, respectively; fourth longest, fifth subequal to it; procumbent spine absent. Second anal spine a little stouter than third, the two subequal in length. Ventral about reaching anus, its base a little behind that of pectoral. Pectoral long, falcate, reaching to over base of first to third anal spines. Caudal well lunate, upper lobe longer than lower.

Measurements of 3 specimens 366-425 mm, and two specimens 228-263 mm including the holotype, those of the smaller specimens in parentheses: Caudal (upper lobe) 29 (32.0-32.5), ventral 19.5-23.0 (23.5-24.0), pectoral 36.5-38 (35.5), depth 36.0-39.5 (38.5-40.5), head 30.5-32.5 (33.5-34.5), maxillary 13.0-13.5 (13.5), snout 13.5-16.0 (15.0), eye 7.0-7.5 (9.0-9.5), preorbital (across its greatest width, on a line oblique to axis of fish) 8.5-9.5 (9.5).

Ground color almost uniformly yellowish sometimes with a slight pinkish blush; upper half of body with many very small brownish spots, irregularly scattered above lateral line, roughly tending to an arrangement along longitudinal lines below it. The small spots are present in 4 specimens, 212-428 mm, which were preserved during the last 12 years, and absent in all others preserved for 25 years or longer. Apparently they disappear after long immersion in preservative. In life the ground color is of a reddish tinge and the spots are bluish.

*Holotype*.—U. S. N. M. no. 151881. 25 miles south of Pensacola, Fla., on snapper bank; 45 fathoms; July 31, 1938; collected by the *Pelican*; 208 mm in standard length; the caudal damaged at tip, about 263 mm in total length.

*Paratypes*.—Pensacola, Fla. (21339, 30838); off Cape Fear, N. C. (collected by the Albatross III); Charleston, S. C. (20981); Rio de Janeiro (83181), Brazil; a specimen obtained by the trawler *Santa Maria* on the coast of Brazil, locality not stated (87741); New York market (22868-9). Total paratypes 15, 138-507 mm.

*Remarks*.—This porgy, which is not uncommon on the American coast and sometimes enters the commercial catch, has been identified hitherto with the European *Pagrus pagrus*. However, the corresponding populations from the two sides of the Atlantic represent distinct species, as determined by comparing the 16 American specimens which form the basis of the preceding account with three specimens 155-391 mm from the Azores.

The American species normally has 16 pectoral rays, the three Azores specimens 15. As the total

number of available specimens are relatively few, the rays in both pectorals were counted for each fish. As stated above, of 32 counts of American fish 29 were 16 and 3 were 15. The six counts of Azores fish were all 15. Hence, out of 32 American counts three intergrade with the European species. This gives an index of divergence of 95 (Ginsburg, 1938), which is of species magnitude, judged by the small samples examined.

The American species has a slenderer caudal peduncle, as shown in Table 2, with no intergradation between the specimens measured.

Another possible difference refers to color. As described above, the American species has very small spots which disappear after long immersion in preservative, while no such spots are mentioned in descriptions of *Pagrus pagrus* by European authors which were consulted.

TABLE 2.—FREQUENCY DISTRIBUTION OF THE DEPTH OF THE CAUDAL PEDUNCLE IN *PAGRUS PAGRUS* AND *P. SEDECIM*, EXPRESSED AS A PERCENTAGE OF THE STANDARD LENGTH

Species	9.0	9.5	10.0	10.5	11.0	11.5
<i>sedecim</i> .....	1	6	6	2		
<i>pagrus</i> .....					2	1

***Archosargus oviceps*, n. sp.**

GULF SHEEPSHEAD

D XI-XII (XIII) 11-12. A III 9-10. P 15-17. Sc 45-49.

Dorsal spines modally 12 (in 20), very often 11 (in 11), infrequently 13 (in 1); dorsal rays modally 11 (in 20), very often 12 (in 12); number of spines and rays highly correlated, variants having 12 spines usually also having 11 rays and vice versa (D XII 11 in 17; D XI 12 in 10; D XII 12 in 2; D XI 11 in 1; D XIII 11 in 1). Anal spines constant; anal rays modally 10 (in 8), very often 9 (in 4). Pectoral rays modally 16 (in 16), often 17 (in 6), sometimes 15 (in 2). Gill rakers short, stubby, 6 or 7 on upper limb of first gill arch and 8 or 9 on lower, or 14-16 altogether. Notably deep, depth about one-half the standard length; anterior profile curving steeply to dorsal origin. Mouth rather small, terminal, only slightly inclined, nearly horizontal; the two jaws subequal in front. Maxillary ending under anterior margin of eye. Preorbital notably wide. Outer teeth broad incisors, confined to anterior part of jaws, six in upper jaw, eight in lower, with three notches or four cusps in young, becoming worn with growth; inner molars well

developed, those behind incisors smaller and in three irregular rows, those on side notably broader and in two rows in lower jaw, three rows in upper jaw; no teeth on vomer, palatines or tongue. Opercle of nearly uniform thickness, forming a rather broad, rounded projection posteriorly, without spines (the projection nearly spinelike in small fish). Margin of preopercle slightly serrate to smooth. Anterior boundary of scalation a nearly horizontal, curved line with its apex on a vertical about through anterior margin of eye or a little behind; interorbital only partly scaled; cheek with a moderately broad, bandlike scaled area, tapering upward, anterior boundary of scales on cheek a line a little behind eye to end of maxillary; opercle and interopercle scaled; preopercle, preorbital, snout and lower jaw scaleless. Lateral line rising moderately upward, running at a considerable distance from, and nearly parallel to dorsal contour, slightly nearer it posteriorly than anteriorly, making a moderate curve at caudal peduncle. Anterior four dorsal spines rapidly and somewhat unevenly graduated, the first a little more than half as long as second, the fourth only slightly shorter than fifth and longest, thence gradually decreasing in length to last or penultimate; first ray moderately longer than last spine, emargination between spinous and soft parts of dorsal very moderate. Second anal spine longer and stouter than third. Ventral placed behind pectoral, about reaching anus, the outer ray usually a little prolonged. Pectoral about reaching third body band, that is, a vertical through approximately third anal spine. Caudal moderately emarginate.

Measurements of two specimens 103-115 mm and 2 large ones 235-247 mm, expressed as a percentage of standard length, measurements of smaller specimens in parenthesis. Caudal, slightly frayed (31-31.5) 30-30.5; ventral (29-29.5) 27-28; pectoral (35.5-36) 41-41.5, a little damaged in larger specimens; depth (48-53) 50.5-52.5; head (33.5 in both) 33-34; maxillary (12-13) 13 in both; snout (13.5-14.5) 15.5-17; eye (9-9.5) 7-7.5; interorbital (11-12) 11.5-12.5.

Sharply cross banded; a band on nape somewhat oblique, tapering downward, not extending on head, usually not as intensely pigmented as posterior bands; body with 5 broad black sharply marked bands extending nearly all the way down; first and fourth bands under beginning and end of dorsal, respectively, only two other bands under dorsal base; last band at caudal base; a transverse blotch on caudal, at its base, often

present, somewhat coalescent with last band; an axillary spot on lateral line, placed on and more intensely pigmented than first body band, sometimes imperceptible; ground color grayish with a

silvery or golden tinge; dorsal, anal and ventral almost uniformly dark to nearly black; caudal dusky; pectoral yellowish.

Only two small specimens, 14–35 mm, have an

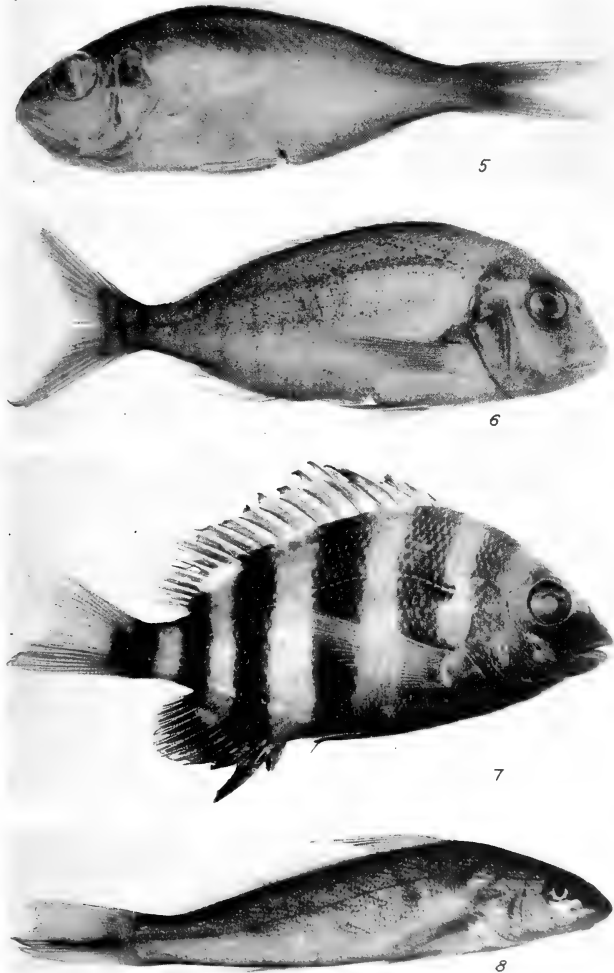

FIGS. 5-8.—5, *Pristipomoides andersoni*, n. sp., holotype; 6, *Pagrus sedecim*, n. sp., holotype; 7, *Archosargus oviceps*, n. sp., holotype; 8, *Menticirchus focaliger*, n. sp., holotype.

asymmetrical color pattern, five body bands on one side, six on the other. All other 76 specimens have 5 body bands on both sides, except that in four of the smallest specimens the last one, or two bands are more or less faint or irregular. As in *probatocephalus* (see below), specimens with an asymmetric color pattern possibly die before attaining any considerable size.

*Holotype*.—U. S. N. M. no. 144151. Barataria Bay, La.; Isaac Ginsburg; November 24, 1931; in shrimp trawl; 103 mm.

*Paratypes*.—Mobile, Ala. (19525). New Orleans, La.; Couch (727). Galveston, Tex.; D. S. Jordan (31041). Port Lavaca, Tex.; Graham (726). Brazos Santiago, Tex.; Emory (728) and J. Wurde-mann (730). Tampico, Mexico; Snyder (62282). The following were collected on the coast of Texas by J. C. Pearson, in 1926: Gulf of Mexico (144158). Harbor Island (144152-5 incl., C. N. H. M.). Shamrock Cove (144156). Ingleside (144157). Corpus Christi (144160). Corpus Christi Pass (144159). Total paratypes 77 specimens, 11-355 mm.

*Remarks*.—This species differs from *A. probatocephalus* in normally having five bands on the body, not counting the band on the nape, instead of six. The band on the nape, the one at the caudal base, and one each under the beginning and end of the dorsal, occupy the same positions in *oviceps* and *probatocephalus*; but between the latter two bands *oviceps* has only two others, while *probatocephalus* has three. Other structural differences between the two species are not pronounced; *probatocephalus* apparently averaging a slightly higher dorsal spine count and slightly lower pectoral and gill raker counts.

Of the South American *A. aries* only one specimen was examined, from Venezuela. It is apparently nearer to *probatocephalus* than to *oviceps*. *A. aries* has six body bands like *probatocephalus*, but the bands are appreciably narrower. In meristic counts the single Venezuelan specimen agrees with *probatocephalus*, and the differences between *aries* and that species remains to be determined by a study of adequate samples.

#### *Archosargus probatocephalus* (Walbaum)

As the only substantial character determined that distinguishes *oviceps* from *probatocephalus* refers to the number of bands, a study of the variability and development of this character in *probatocephalus* was made for comparative purposes. Variation in the number of bands is shown

TABLE 3.—FREQUENCY DISTRIBUTION OF NUMBER OF BODY BANDS IN ARCHOSARGUS PROBATOCEPHALUS

Locality	Length of specimens in mm	Distribution		
		6	6/5	5
Beesleys Point, N. J.	25-74	24	—	1
Beaufort, N. C.	10-68	182	24	13
Miscellaneous, Chesapeake Bay to Key West	71-361	19	—	—
Homosassa and Tampa Bay, Fla.	92-252	6	—	—

TABLE 4.—FREQUENCY DISTRIBUTION OF NUMBER OF BODY BANDS IN ARCHOSARGUS PROBATOCEPHALUS AS RELATED TO SIZE OF SPECIMENS

Number of body bands \ Length of specimens in mm.	Length of specimens in mm.				
	10-25	26-41	42-58	59-74	92-361
6	68	80	53	6	24
6/5	5	16	3	—	—
5	5	5	3	1	—

in Table 3. All specimens are divided into three groups: (1) With six body bands, not including the incomplete band on the nape, (2) with five body bands, and (3) asymmetrical, five bands on one side, six on the other, the column heading being "6/5". Of the 269 specimens examined (six from western Florida, the rest from the Atlantic), 24 or slightly less than 9 percent are asymmetrical, and 14 or a little over 5 percent have five bands. The total of both variant categories is slightly over 14 percent.

Table 3 also shows that all variants except one are from Beaufort. The latter composite sample comprises young fish, 10-68 mm, which formed the basis of the account of development of the species by Hildebrand and Cable (1938), and a study was made of the development of the bands in this species.

At 10 mm the bands are not sharply outlined, but the chromatophores are already crowded in definite transverse areas which are separated by narrower intervals that are almost devoid of chromatophores. By this arrangement the number of bands in fish as small as 10 mm is determinable. On growing another 2-5 mm, the bands become sharply outlined.

Table 4 shows the grouping of the variants with respect to size. They are present in the smaller size groups and evidently disappear with growth. The largest 5-banded fish is 74 mm, the largest asymmetrical specimen 53 mm. Speci-

mens 92 mm or longer, 24 in all, have a symmetrical 6-banded pattern. An obvious and plausible explanation is that in *probatocephalus* an asymmetric and a 5-banded color pattern is linked with a lethal factor which results in the failure of such variants to reach some size, much less to reach adulthood. It can hardly be explained that the asymmetric or 5-banded pattern changes with growth to a 6-banded pattern, as the position of the bands is constant and there would have to be a radical rearrangement of the chromatophores to produce this change, which is hardly probable. The isolating mechanism that keeps *probatocephalus* and *oviceps* as separate species, therefore, seemingly includes two factors, one geographic, and another which may be termed physiologic, using the term in a broad sense. While the evidence is not based on a sufficient number of specimens to be altogether conclusive, it is fairly presumptive of this conclusion.

#### Family SCIAENIDAE

#### *Menticirrhus focaliger*, n. sp.

#### GULF MINKFISH

D X; I 24-25. A I (7) 8. P 19-21. Sc 75-86.

Dorsal rays 24 (in 6) or 25 (in 5). Anal rays normally 8 (in 26), infrequently 7 (in 1). Dorsal and anal spines constant (in 11). Well elongate; rather fusiform, but tapering posteriorly more than anteriorly and upper profile more curved than lower. Snout long, bluntly rounded at tip, somewhat conical, projecting beyond upper lip. Mouth small, nearly horizontal, notably inferior, placed well behind tip of snout. Maxillary ending under middle of eye or posterior margin of pupil. Interorbital subequal to eye diameter. A single, short, rather stout, truncate barbel at chin. Lower jaw with five pores, one on midline of chin, at base of barbel, two on both sides. Anterior margin of snout with four lobes well developed. Teeth in jaws in rather broad bands; small, except outer teeth in upper jaw rather well enlarged, the others subequal; vomer and palatines toothless. Gill rakers short, rather stout, stumpy, comparatively few, the anterior 2 or 3 gill rakers on lower limb better marked in the smaller specimens, reduced to low tubercles or to a few spinules at the surface or hardly perceptible in the larger specimens (hence the tubercles were not counted, and the gill raker count differs with size), 5 + 7-10 in the smaller specimens (four specimens 53-81 mm), 5 + 6-8 in the larger (six specimens 90-132 mm). Hard part

of opercle ending in two widely separated, moderately pungent or flexible points, without well marked spines. Preopercle moderately serrulose or crenate, the points moderately pungent or flexible. Scaled all over; except a moderate area at anterior end of snout naked; scales on chest subequal, the middle scales not notably smaller than those at periphery; scales on lateral aspect of snout and anterior part of cheek cycloid, others ctenoid; proximal part of caudal scaled, distal part scaleless, except the modified lateral line scales extending to its distal margin; ventral and pectoral scaled for a short distance at base; a single row of scales on second dorsal base; spinous dorsal and anal scaleless. Spinous and soft dorsal well separated, forming two fins; the spines flexible; second to fourth spines prolonged, the third longest; extent of prolongation varying greatly with the individual and increasing with growth, tip of longest spine reaching base of third to eighth dorsal ray in specimens 53-103 mm (25 fish), to base of ninth ray in specimens 115-132 mm (2 fish). The single anal spine flexible in the larger specimens, moderately pungent in small ones. Ventral placed at some distance behind pectoral base, falling considerably short of anus. End of pectoral falling a little short of a vertical through end of ventral in the smaller specimens, extending to or a little behind that vertical in the larger fish. Caudal asymmetrical, lower part rounded, longer than upper part, the latter emarginate.

Measurements of six specimens 90-132 mm, including the holotype expressed as a percentage of standard length: Caudal (lower part) 25-27.5, ventral 18-20, pectoral 20-22, depth 24-25, head 30-31.5, maxillary 10.5-11, snout 10-11, eye 6-7.5, interorbital 6.5-7.5.

Ground color light yellowish or grayish; with dusky or black rather wide bands; four oblique bands under dorsal fin running downward and forward, the first band under end of spinous dorsal continued upward on posterior part of fin, the fourth at some distance before end of soft dorsal, the bands decreasing in length and increasing in obliquity from first to fourth; two oblique bands on nape running in opposite direction to preceding series, downward and backward; the first band of the posterior series and the second band of the anterior series forming a broad V on side; caudal with a dusky longitudinal band along middle of its lower half, often rather faintly continued forward on posterior part of

TABLE 5.—FREQUENCY DISTRIBUTION OF THE NUMBER OF SCALES AND PECTORAL RAYS OF MENTICIRRHUS FOCALIGER AS COMPARED WITH M. SAXATILIS.

Species	Scales														Pectoral rays																							
	75	76	77	78	79	80	81	82	83	84	85	86	87	88	89	90	91	92	93	94	95	96	97	98	99	100	101	102	103	104	18	19	20	21				
<i>focaliger</i> .....	1	1	2	2	4	4	4	1	2	1	2	2																							2	3	17	4
<i>saxatilis</i> :																																						
North Carolina .....																2	3	1	1		2	1	1	1											1	2	8	
Woods Hole .....																			1		2	1	1	1		1	2							10	6			

body. The oblique bands described above are sometimes sharply black and sometimes hardly perceptible. Usually they are of a diffusely dusky pigment. In general the bands are better marked in the smaller specimens. In life they are more sharply outlined than in preserved specimens.

*Holotype*.—U. S. N. M. no. 144161. St. Joseph Bay, Fla., near its entrance; Isaac Ginsburg; June 21, 1932; 132 mm.

*Paratypes*.—Five specimens 90–114 mm, obtained with holotype (U. S. N. M. no. 144163). Cape San Blas, Fla.; Isaac Ginsburg; June 20, 1932; 21 specimens 53–103 mm (U.S.N.M. no. 144162; C.N.H.M.).

*Remarks*.—I obtained the above 27 specimens on two successive days at two localities not far apart by means of a 30-foot seine on sandy beaches. Several drags of the net were made at each place and every drag brought in one or more specimens of *focaliger*. Very likely I could have obtained more specimens by further seining; but at the time I thought that they represented the

common *saxatilis*. At Cape San Blas, 38 specimens of *M. americanus* and 5 of *M. littoralis* were obtained in the same drags as the 21 *focaliger*. Evidently the three congeneric species live and mingle side by side.

This species is close to *M. saxatilis* from the Atlantic, nearly agreeing with it in normally having 8 anal rays, in the extent of prolongation of the dorsal spines, in the color pattern and the size of the scales on the chest. It differs chiefly in having a lower scale count as shown in Table 5. While counts of more specimens might show some overlap in the distributions of the two species, the extent of divergence is evidently of species magnitude or very close to it. The populations of *saxatilis* from Woods Hole and North Carolina also differ in the scale count, possibly to an extent to be treated as distinct subspecies; but such is not unusual for north and south populations of the same species. The pectoral count of *focaliger* is nearer to the Woods Hole population of *saxatilis* than to the North Carolina population.

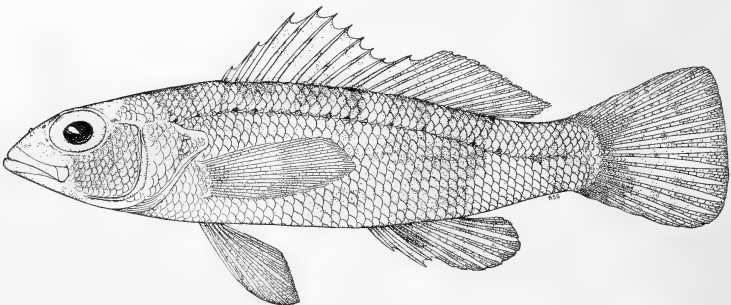

FIG. 9.—*Serraniculus pumilio*, n. gen. and sp., drawn from a paratype by Ann S. Green.

## NOTES ON THE GEOGRAPHIC DISTRIBUTION OF THE FISH FAUNA OF THE EAST COAST OF THE UNITED STATES WITH PARTICULAR REFERENCE TO THREE OF THE SPECIES ESTABLISHED ABOVE

The relationship of the temperate-water, marine fish fauna of the Atlantic and Gulf coasts of the United States constitutes an interesting problem in zoogeography. The peninsula of Florida forms an effective natural barrier to the spread, and results in the isolation, of fish populations. The Gulf fish fauna from the Rio Grande (very little is now known of the fishes on the Mexican coast), say, roughly to Cape Romano, Fla., is on the whole very similar to the temperate-water fish fauna of the Atlantic coast of the United States. Most species of both coasts are nearly identical (with some qualifications as discussed below). The southern limit of the temperate Atlantic fauna is somewhere between Cape Canaveral and Biscayne Bay, Fla. The fauna of the extreme end of southern Florida, on the other hand, from Biscayne Bay to Tortugas, is in its larger aspects tropical and very similar to or nearly identical with the West Indian fish fauna and that of central and the tropical part of South America. The very similar temperate fish faunas of the Atlantic and Gulf coasts are thus isolated by the physical barrier of the peninsula of Florida and by the ecological barrier of the tropical waters at the Florida keys.

The division between the temperate water and tropical fish faunas is not sharp. Many species do have a discontinuous geographic range. They occur on the Atlantic and Gulf coasts of the United States; but their geographic distribution is interrupted by their absence at the Florida keys. On the other hand, from the viewpoint of zoogeography, a second category contains many species, in the families Carangidae and Lutjanidae for instance, which have a continuous range, from the Atlantic coast, around the Florida keys, to the Gulf coast and also to the West Indies and Central America. The ichthyofauna at the Florida keys is not well enough known to make a numerical comparison of the species in these two categories. Whatever the relative number of species in the two categories, those species which by their preponderance in numbers give character to the fauna, have a discontinuous distribution. For instance, the temperate-water channel bass, croaker, spot, sea trouts, and menhaden, species that dominate the faunal scene by their abundance, have a discontinuous distribution. Also, most species having a continuous geographic range, typically belong rather to the

tropical fauna. Their center of abundance is at the West Indies, the Florida keys and the coast of Central America, and occur only sparingly farther north on the Atlantic and Gulf coasts of the United States. Fewer species with a continuous geographic range, such as the sheepshead and the pigfish, typically belong to the temperate water fauna and occur in much reduced numbers at the Florida keys.

As a general rule species are not uniform morphologically throughout their geographic ranges; they differ more or less with the local population. Two species having a continuous distribution, which I have studied in detail, namely, *Bathygobius soporator* (Cuvier and Valenciennes), sensu lato (Ginsburg, 1947), and *Bathystoma aurolineatum* (C. and V.), sensu lato (1948) show that the populations of the Florida keys are somewhat intermediate, between the comparable West Indies populations and those farther north on the coast of the United States.

Comparisons made of the corresponding pairs of populations—one from the Atlantic, the other from the Gulf—of species having a discontinuous geographic range show that they too diverge more or less morphologically. The extent of divergence of comparable pairs is of different degrees and their magnitudes form a graded series, from very slight to very pronounced, with all gradations in between. (A difference in degrees of divergence among species of the same genus even, is mentioned above under the account of *Centropristes melanus*.) An example near the low end of the series is furnished by the Atlantic and Gulf populations of *Cynoscion nebulosus* as discussed by me in another paper (1938), which also gives a number of other, graded divergences at or below the subspecies level. The divergences of two corresponding pairs, namely, *Brevoortia tyrannus* from the Atlantic as compared with *B. patronus* from the Gulf, and *B. smithi* as compared with *B. gunteri*, recently published by Hildebrand (1948), are evidently of higher degrees, near the borderline between species and subspecies. The divergence of two pairs compared above, namely, *Centropristes striatus* with *C. melanus* and *Menticirrhus saxatilis* with *M. focaliger*, is approximately the same as the above named two pairs compared by Hildebrand. Finally, as an example near the other extreme, that of very pronounced diver-

gence, the two species of *Stenotomus* may be cited. *S. chrysops* (Linnaeus) is common on the Atlantic coast of the United States and is replaced on the Gulf coast by *S. caprinus* Bean which is not known to occur in the Atlantic. This is an example of two closely related allopatric species which replace each other geographically but which are so highly divergent that they are often placed by authors in separate genera.<sup>1</sup>

In sum, subject to the qualifications and exceptions discussed, by and large, the fish fauna of the Florida keys is tropical and West Indian, while that of the Gulf is very similar to the temperate water Atlantic fauna. The two very similar temperate water faunas are isolated by the peninsular barrier. This barrier is such a striking feature in the geographic distribution of the ichthyofauna that it could not have escaped the notice of students of fishes. But it is only lately that a beginning was made towards a detailed study and evaluation of the results of its influence on the ramification of fish populations. In any further studies, it would be interesting to note whether the change in the general character of the fauna at the lower end of the peninsula of Florida is fairly abrupt or gradual, and if abrupt at what area the change occurs.

The geographic distribution of three species described here is not in line with the general relationship of the temperate faunas on both sides of the now existing peninsular barrier as discussed above. The sheephead, *Archosargus probatocephalus*, is one of those fewer among the typically temperate-water species that have a continuous geographic distribution, occurring as

it does, in reduced numbers, in the Florida keys. A comparison of the specimens examined from Tampa Bay and Homosassa with those from the Atlantic coast makes it evident that any divergence that might exist between the Atlantic and west Florida populations will prove to be of very minor degree, decidedly below the subspecies level. This relationship is similar to that of the populations of many other species on the opposite sides of the peninsular barrier. However, in the case of the sheephead, something different is also indicated. The population on the west coast of Florida differs materially from the comparable population on the coast of Alabama, Louisiana, Texas, and Mexico, the difference being such that they may be treated as distinct species; that is, on the Gulf coast westward of Florida *probatocephalus* is replaced by a distinct species, *oviceps*. A similar, though not parallel, difference in distribution is indicated further by two other species here described, *M. focaliger* and *C. melanus*.

The two species of *Menticirrhus* compared above, *focaliger* and *saxatilis*, are examples of two corresponding populations that replace each other on the two sides of the peninsular barrier and that have attained a divergence of species magnitude. This also is not unusual. Similar instances have been cited above. However, *focaliger* apparently does not occur on the Gulf coast westward of Florida. Of the thousands of specimens I closely examined or observed on the coast of Louisiana and Texas, not a single *focaliger* was found; they all comprised two species, *americanus* and *littoralis*, which also occur on the west Florida and Atlantic coasts. *M. focaliger* is also lacking among the many specimens of *Menticirrhus*, which John C. Pearson preserved during his study of the sciaenids of the Texas coast, and it was not found in the National Museum. It seems safe to conclude, therefore, that it does not occur in the Gulf west of Florida. Apparently this also holds for *Centropristes melanus*. The latter species has been masquerading heretofore under the name *C. striatus*. There are no indisputable records of its having been taken westward of Florida. I have not encountered it in my collecting trips from Alabama to Texas; and no specimens from the coast of those States are present in the large collection of *Centropristes* in the National Museum. Weed (1937) gives an extensive annotated bibliography of *Centropristes*. None of the references cited contain an undoubted record of the black seabass west of

<sup>1</sup> As the above statements regarding *Stenotomus* are at variance with published accounts, it should be here said that they are based on original and as yet unpublished data and observations. I did this work in preparing an account of the Gulf coast fishes. The specimens of *Stenotomus* examined from the Atlantic range from the Bay of Fundy in the north to Cape Canaveral, Fla.; those of the corresponding population in the Gulf range from Pensacola, Fla., to Aransas Pass, Tex. Of the Atlantic material a few specimens from near the extremes of their geographic range were studied in detail and compared with those in the Gulf. All available specimens, more than 100 in number, were then examined for the most critical distinguishing characters. As a result of these studies I have come to the conclusion that only two species of the common scups are known, namely, *Stenotomus (Stenotomus) chrysops*, which is confined to the Atlantic, and *Stenotomus (Otrynter) caprinus*, which is confined to the Gulf. Judged by analogy, by the distribution of *Archosargus probatocephalus*, as determined during this investigation and recorded above, *S. chrysops* might occur in western Florida, but this remains to be determined.



Florida. One reference, that by Collins and Smith, recording *C. striatus* as being a commercial species in Mississippi, is most probably based not on actual specimens but on reports of fishermen and fish dealers, and it very likely refers to some other species designated "seabass" in the fish trade of Mississippi, rather than to *Centropristes*. The specimens that Weed designated as *striatus* and that are designated above *melanus* all came from Florida.

Still another example, again not altogether parallel, is furnished by the species of *Hippocampus* (Ginsburg, 1937). *H. zosterae* occurs on the coast of Florida and is replaced on the coasts of Mississippi and Texas by the closely related and morphologically somewhat overlapping *H. regulus*. This case is not altogether parallel in as much as *H. zosterae* is not known to occur in the Atlantic north of Biscayne Bay; but it indicates a marked difference in the fish fauna between the Gulf coast of Florida and the coast westward of Florida.

The peculiar geographic distribution of the four species discussed, as compared with their close relatives, challenges a rational explanation. On the surface the existing ecological conditions on the greater part of the Florida west coast are not so strikingly different from those of most other parts of the Gulf coast as to account for this difference in geographical distribution. Yet, in some important elements, the fish fauna of the Gulf coast of Florida differs markedly from that of the coast of Alabama and westward and is nearer to that of the Atlantic coast.

In our present state of knowledge only speculative suggestions may be made. One such suggestion would be the existence of some past or present barrier, now unrecognized. On this assumption the thought that comes to mind first is an ecological barrier, namely, the soft or muddy nature of the bottom in the delta region resulting from the tremendous mass of silt carried down by the Mississippi River. But, while this may be a partial factor in isolating fish populations, it evidently does not offer a full explanation of the peculiar distribution here discussed. Most species are able to surmount this barrier. Moreover, the fauna on the coasts of Alabama and Mississippi, on the east side of the Mississippi Delta, is the same as far as we know now as that of Louisiana and Texas, west of the delta. Another assumption would be the probable existence of a faunal barrier, similar to the now existing peninsular barrier, physical or ecological, in some past geologic epoch, perhaps the Pliocene, some-

where between what is now Cape San Blas, Fla., and Mobile Bay, Ala. This hypothetical barrier must have antedated the peninsular barrier as it now exists. It produced its effect in isolating fish populations when the west coast of Florida was still continuous with the Atlantic coast, at least when it was climatologically and ecologically uninterrupted and supporting the same fauna. The proof of such a hypothesis, of course, lies within the province of historical geology as well as zoogeography. My main object here is to place the zoogeographic evidence on record as it relates to fishes, for the purpose of correlation with similar evidence that might exist for other groups or that might be discovered in the future study of fishes.

#### LITERATURE CITED

- BOULENGER, GEORGE ALBERT. *Catalogue of the perciform fishes in the British Museum*, ed. 2, **1**, 1895.
- CUVIER, GEORGES, and VALENCIENNES, ACHILLE. *Histoire naturelle des poissons* **3**, 1829.
- FOWLER, HENRY W. *Notes on Serranidae*. Proc. Acad. Nat. Sci. Philadelphia **59**: 249-269. 1907.
- GINSBURG, ISAAC. *Review of the seahorses (Hippocampus) found on the coasts of American continents and of Europe*. Proc. U. S. Nat. Mus. **83**: 497-594. 1937.
- . *Arithmetical definition of the species, subspecies and race concept, with a proposal for a modified nomenclature*. Zoologica **23** (3): 253-286. 1938.
- . *American species and subspecies of Bathygobius, with a demonstration of a suggested modified system of nomenclature*. Journ. Washington Acad. Sci. **37** (8): 275-283. 1947.
- . *The species of Bathystoma (Pisces, Haemulonidae)*. Zoologica **33** (3): 151-156. 1948.
- HILDEBRAND, SAMUEL F. *A review of the American menhaden, genus Brevoortia, with a description of a new species*. Smithsonian Misc. Coll. **107** (18): 1-39. 1948.
- and CABLE, LOUELLA E. *Further notes on the development and life history of some teleosts at Beaufort, N. C.* Bull. U. S. Bur. Fish. **48** (24): 505-642. 1938.
- JORDAN, DAVID STARR. *Notes on typical specimens of fishes described by Cuvier and Valenciennes and preserved in the Musée d'Histoire Naturelle in Paris*. Proc. U. S. Nat. Mus. **9**: 525-546. 1887.
- and EIGENMANN, CARL H. *A review of the the genera and species of Serranidae found in the waters of America and Europe*. Bull. U. S. Fish Comm. **8**: 329-441. 1890.
- and EVERMANN, BARTON W. *The fishes of North and Middle America*. Bull. U. S. Nat. Mus. **47** (1): 1-1240, figs. in separate volume. 1896.
- WEED, ALFRED C. *Notes on seabasses of the genus Centropristes*. Publ. Field Mus. Nat. Hist. Zool. **20** (23): 291-320. 1937.

MAMMALOGY.—*A new Clyomys from Paraguay (Rodentia: Echimyidae). João Moojen, Museu Nacional, Rio de Janeiro, Brazil. (Communicated by Herbert Friedmann.)*

Among the mammal specimens collected by Charles Wharton in Paraguay is an apparently undescribed form of the genus *Clyomys*. Hitherto this genus has been known only from specimens obtained by Lund at Lagôa Santa, Minas Gerais, Brazil. This new form appears to be subspecifically distinguishable, as follows:

*Clyomys laticeps whartoni*, n. subsp.

*Type*.—Museu Nacional no. 11400, adult male; collected on May 5, 1950, by Charles Wharton.

*Type locality*.—1 km north of Aca-poi, long. 56°7' W., lat. 23°5' S., Department of San Pedro, Partido de Taquatí, Paraguay; approximately 60 km east-northeast of Puerto Ybapobo and 10 km south of the Rio Ypané. Specimen trapped alive at mouth of burrow in cañadon (natural opening).

*Diagnosis*.—Head grizzled ferruginous and black, more uniformly ferruginous on the nose and cheeks. Back rufous strongly mixed with black, the amount of black decreasing to the sides of body and caudad. Sides of the body and primna more uniform cinnamon. Tail like back in the proximal fifth, covered with stiff blackish hairs in the remaining portion. Hands and feet finely grizzled whitish and rufous with some black intermixed. Ventral surface grayish white with gray patches in the gular region and middle of chest and belly.

*Pelage*.—Aristiforms on shoulder: Grayish basally, gradually blackening toward tip but interrupted by an Apricot Orange subapical zone: about half of them with no subapical zone and therefore completely black in the distal part; groove of aristiforms dorsal, as in *Euryzgomatomys*; total length 18 to 20 mm; maximum width 0.5 to 0.6 mm.

Setiforms on shoulder: Whitish basally, gradually darkening toward tip but interrupted by an Apricot Buff subapical zone; total length about 18 mm; maximum width 0.1 to 0.2 mm.

Aristiforms on middorsal region: Grayish basally, gradually blackening toward tip but most of them interrupted by an Apricot Buff subapical zone; total length 20 to 23 mm; maximum width 0.8 to 0.9 mm.

Setiforms on middorsal region: Grayish basally,

gradually darkening toward tip but interrupted by a broad Salmon-Buff subapical zone; total length 15 to 20 mm; maximum width 0.02 mm.

Setiforms on thighs: Almost uniformly with a broad Apricot Buff subapical zone.

*Measurements*.—Dry skin: Head and body, 190 mm; tail, 69 mm; hind foot (c.u.) 36 mm; ear, 16 mm.

Skull: Greatest length, 46.9 mm; basal length, 44.5 mm; zygomatic breadth, 26.5 mm; length of nasals, 14 mm; interorbital breadth, 11.7 mm; palatilar length, 17.6 mm; bullae, 14.6 by 10.4 mm; crown length of cheek teeth, 9.3 mm.

*Comparisons*.—This new subspecies differs from *C. l. laticeps* in having grayish patches on the gular region and median ventral surface. The palate is shorter and the bullae are larger than in *C. l. laticeps*.

*Remarks*.—The discovery of *Clyomys laticeps* in Paraguay considerably extends its range, showing that the species probably lives in the whole savannah region of the South American central plateau. Since it is now known from Lagôa Santa, Minas Gerais, Brazil, and Taquatí, Paraguay, it should follow the pattern of distribution of other genera in the same family, as for instance *Cercomys*, *Euryzgomatomys*, and *Carterodon*, which live in similar habitat.

The fact also that Mr. Wharton was not able to find the species in Summerfeld Colony, Department of Yhú, lat. 25°20' S., and long. 55°45' W., supports the assumption that most of the Echimyidae do not go below lat. 24° S. in spite of topographical and floristical conditions.

Mr. Wharton intends to publish on the habits of the subspecies.

An old adult female was also examined, collected by Mr. Wharton in the same locality, and will be deposited in the U. S. National Museum collection. The color of this specimen is considerably lighter than that of the type, the subapical zone of the aristiformes being Salmon-Buff. Its measurements are: Skin (in the flesh): Head and body, 107 mm; tail, 75 mm; hind foot, 21 mm. Skull: Greatest length, 47.1 mm; basal length, 44.1 mm; zygomatic breadth, 26.5 mm; length of nasal, 13.0 mm; interorbital breadth, 10.9 mm; palatilar length, 17.1 mm; bullae, 14.4 by 10.1 mm; crown length of cheek teeth 9.1 mm.

ORNITHOLOGY.—*A new finch from northern Perú.* JOHN T. ZIMMER, American Museum of Natural History. (Communicated by Herbert Friedmann.)

A small consignment of Peruvian birds, recently submitted by Javier Ortiz de la Puente, of the Museo de Historia Natural 'Javier Prado' of Lima, Perú, contained, among other interesting specimens, a fine new finch belonging to the genus *Incaespiza*. Señor Ortiz de la Puente has kindly given me permission to describe this new bird and, in addition, has generously given the type to the American Museum of Natural History, for which I am grateful.

I am also indebted to Rodolphe M. de Schauensee, of the Academy of Natural Sciences of Philadelphia, for the loan of a specimen of one of the allied species of *Incaespiza*, not contained in the American Museum series, and one additional young individual of uncertain affinity. Both examples were examined some years ago but were studied again in comparison with the new form.

The new bird may be known as follows. Names of colors are capitalized when direct comparison has been made with Ridgway's *Color standards and color nomenclature*.

*Incaespiza ortizi*, n. sp.

*Type*.—From near La Esperanza, Dept. Cajamarca, Perú; altitude 1,800 meters. Amer. Mus. Nat. Hist. no. 748395. Adult female collected April 24, 1951, by Javier Ortiz de la Puente.

*Diagnosis*.—Somewhat similar to *I. pulchra* of central-western Perú (Departments Ancash to Lima at approximately the same elevations) but differing in various respects. Upper parts darker and duller, more streaked and without any bright rufescence; gray of breast lighter and clearer, being broadly extended down the flanks; belly white, without buff; facial pattern different, having broader black on the front and a more restricted black gular patch, which, however, is broadly connected with the lores; no gray superciliary stripe over the lores and only a weak suggestion of one between the black orbital ring and the crown; feet paler yellowish. The facial pattern rather noticeably resembles that of *I. personata* (of even higher elevations in the Cajamarca region), giving the only obvious feature of resemblance to that species.

*Range*.—At present known definitely only from

the type locality, on the western side of the Andes of northern Perú. Possibly crossing the Andes to the eastern slope of the Western Cordillera.

*Description of type*.—Crown Deep Mouse Gray with poorly defined darker shaft streaks; back of head a little lighter; mantle Hair Brown  $\times$  Mouse Gray with rather broad, sooty shaft streaks, not sharply defined; forehead broadly black with the shading extending over the lores, narrowly around the orbit, broadly over the malar apex, and moderately broadly over the chin; rest of sides of the head Neutral Gray  $\times$  Light Neutral Gray, merging with the Pale Neutral Gray of the throat; breast a little lighter, with traces of whitish shaft lines; flanks broadly Pale Neutral Gray; belly white; under tail coverts whitish, faintly tinged with light buff. Remiges near Hair Brown; primaries with exterior margins finely Drab-Gray; secondaries with this outer margin broader and less well defined; tertials with a brown submarginal area passing into a grayer margin; upper primary coverts dusky with dull grayish margins; greater coverts like the secondaries; median and lesser series gray with lighter margins; under primary coverts dull grayish; remainder of under coverts whitish; inner margins of remiges soiled whitish. Median three pairs of rectrices blackish with prominent gray margins tending to broaden at the tips (worn plumes faded to brown); fourth pair blackish, with a large white patch on the terminal part of the inner web, adjoining the shaft but withdrawn from the inner margin except for a short distance terminally; subexternal pair similarly marked but the white patch reaching well over half the distance basad along the shaft and a third of the distance on the inner margin; outermost pair with the white even more extensive, involving most of both webs except for a dusky diagonal patch at the base and a narrow streak on the outer web near the tip. Bill (in dried skin) Capucine Yellow  $\times$  Deep Chrome; feet Maize Yellow. Wing, 73 mm; tail, 67; exposed culmen, 14.5; culmen from base, 18; tarsus, 26.5.

*Remarks*.—A young male from Hacienda Limón, Perú, kindly lent by Mr. de Schauensee, of the Academy of Natural Sciences of Philadelphia, may be an immature example of the present species, but it is impossible to be certain without adults from the same locality. I have no comparable plumages of *pulchra* or *personata*, but the

characters of this young bird approximate those of adult *ortizi* more than those of either of the other forms. The bill is of much the same conformation; the upper parts are strongly streaked, and the pattern of the tail is very similar. The under parts are dull with prominent pectoral streaks, and there is no facial black although the lores and malar apex (but not the forehead or chin) are somewhat dusky. There is, however, a rather broad superciliary stripe over the orbit and the lores to the base of the bill which may indicate relationship to *pulchra* more than to *ortizi*. For the present I prefer to leave this bird with a query.

The possibility exists that *ortizi* and *pulchra* are conspecific or even, as maintained by Hellmayr, that *pulchra* and *personata* bear that close relationship, but I believe the situation is not sufficiently clear to establish such arrangement without question. The various members of the genus *incaspiza*, including several species that are rather obviously no more than generically related to these three forms, all exhibit notable

similarities in pattern of coloration, and the possession of one or more resemblances of this sort in common is not an adequate criterion of conspecific affinity.

I have been handicapped to a certain extent by lacking a female of *pulchra* or a male of *ortizi*. Throughout the genus *Incaspiza*, however, the sexes show no striking distinctions. Furthermore, both sexes of *pulchra* were studied by Hellmayr, who reported no differences except of size; a female was slightly smaller than two males. Consequently I am confident that the characters of *ortizi* can not be attributed to any sexual differentiation.

I take great pleasure in naming this fine bird for its discoverer.

*Specimens examined*.—As follows:

*I. ortizi*.—PERÚ: La Esperanza, 1 ♀ (type).

*I. pulchra*.—PERÚ: Yuramarca, Dept. Ancash, 1 ♂.<sup>1</sup>

*I. personata*.—PERÚ: Cajabamba, 2 ♂; near Cajamarca, 2 ♂, 4 ♀; Succha, 1 ♀.

*I. species?*.—PERÚ: Hacienda Limón, 1 ♂ juv.<sup>1</sup>

<sup>1</sup> Specimens in Acad. Nat. Sci., Philadelphia.

## Obituary

MERRILL BERNARD was born at Burlington, Iowa, on July 25, 1892. He died in his home in Washington, D. C., on April 13, 1951. He is survived by his wife Claudia Bernard.

Bernard completed his education at the North Carolina Military Academy (Preparatory), Military College of South Carolina, and A. and M. College of Oklahoma, after which he practiced municipal, irrigation, and railroad engineering in Louisiana and Texas. After military service as first lieutenant during the First World War (1917-18) he engaged in consulting engineering practice in Louisiana, Texas, and Central America, including hydrologic consultant for the Mississippi Valley Committee in 1934-1936, and brief associations with the U. S. Geological Survey and the Soil Conservation Service. He became chief, River and Flood Division, U. S. Weather Bureau in 1937, advancing to hydrologic director, 1939, and finally chief, Climatological and Hydrologic Services, in 1946, the position he held at the time of his death. Among the special assignments he accomplished were those of member, American Meteorological Mission to USSR (1945), and meteorological attaché to embassy, Moscow (1946).

His many contributions in the fields of hydrology and meteorology are notably important for their success in clarifying the relationship between these two sciences. His paper *Primary role of meteorology in flood flow estimating* won for him the Norman Medal of the American Society of Civil Engineers in 1945.

In addition to his association with this Acad-

emy, Merrill Bernard was affiliated with the International Association of Hydrology, IUGG, of which he was president; International Meteorological Organization, in which he served as president of their joint subcommittee on machine methods, and vice president of their technical commission on hydrology; American Meteorological Society; American Geophysical Union; and American Society of Civil Engineers.

His widely recognized abilities and professional prestige, combined in action with his personal likability and unvarying loyalty to the Service, gained for the Weather Bureau a great many advantages in its work with such other agencies as the Corps of Engineers, the Bureau of Reclamation, and the U. S. Geological Survey, with whose cooperation, under his active guidance, many major projects of public benefit and value have been developed and are now in continuing operation. Outstanding examples of these are the objectives and output of the hydrometeorological and the cooperative studies sections of the Climatological and Hydrologic Services Division in Washington for which his vision and ingenuity are very largely to be thanked, and which have become indispensable as aids in relating the facts and potentials of storm behavior to the design and location of flood-control and water-conservation construction throughout the country. Less well-defined but of comparable character and value was the success of his effort to extend the flood-forecasting function of the Weather Bureau to upstream and headwater areas.—W. F. F.

## Officers of the Washington Academy of Sciences

*President*..... WALTER RAMBERG, National Bureau of Standards  
*President-elect*..... F. M. SETZLER, U. S. National Museum  
*Secretary*..... F. M. DEFANDORF, National Bureau of Standards  
*Treasurer*..... HOWARD S. RAPPLEYE, U. S. Coast and Geodetic Survey  
*Archivist*..... JOHN A. STEVENSON, Plant Industry Station  
*Custodian and Subscription Manager of Publications*  
 HARALD A. REHDER, U. S. National Museum

### *Vice-presidents Representing the Affiliated Societies:*

Philosophical Society of Washington..... A. G. McNISH  
 Anthropological Society of Washington..... WALDO R. WEDEL  
 Biological Society of Washington..... HUGH T. O'NEILL  
 Chemical Society of Washington..... JOHN K. TAYLOR  
 Entomological Society of Washington..... FREDERICK W. POOS  
 National Geographic Society..... ALEXANDER WETMORE  
 Geological Society of Washington..... A. NELSON SATRE  
 Medical Society of the District of Columbia..... FRED O. COE  
 Columbia Historical Society..... GILBERT GROSVENOR  
 Botanical Society of Washington..... LEE M. HUTCHINS  
 Washington Section, Society of American Foresters..... WILLIAM A. DAYTON  
 Washington Society of Engineers..... CLIFFORD A. BETTS  
 Washington Section, American Institute of Electrical Engineers..... A. H. SCOTT  
 Washington Section, American Society of Mechanical Engineers..... RICHARD S. DILL  
 Helminthological Society of Washington..... L. A. SPINDLER  
 Washington Branch, Society of American Bacteriologists..... ANGUS M. GRIFFIN  
 Washington Post, Society of American Military Engineers..... FLOYD W. HOUGH  
 Washington Section, Institute of Radio Engineers..... HERBERT G. DORSEY  
 District of Columbia Section, American Society of Civil Engineers  
 MARTIN A. MASON

### *Elected Members of the Board of Managers:*

To January 1953..... C. F. W. MUESEBECK, A. T. MCPHERSON  
 To January 1954..... SARA E. BRANHAM, MILTON HARRIS  
 To January 1955..... ROGER G. BATES, W. W. DIEHL

*Board of Managers*..... All the above officers plus the Senior Editor  
*Board of Editors and Associate Editors*..... [See front cover]

*Executive Committee*.... WALTER RAMBERG (chairman), F. M. SETZLER, H. S. RAPPLEYE,  
 WILLIAM A. DAYTON, F. M. DEFANDORF

*Committee on Membership* . . . E. H. WALKER (chairman), M. S. ANDERSON, CLARENCE, COT-  
 TAM, R. C. DUNCAN, G. T. FAUST, I. B. HANSEN, FRANK KRACEK, D. B. JONES, DORO-  
 THY NICKERSON, LEO A. SHINN, F. A. SMITH, HEINZ SPECHT, H. M. TRENT, ALFRED  
 WEISSLER

*Committee on Meetings*.... H. W. WELLS (chairman), WM. R. CAMPBELL, W. R. CHAP-  
 LINE, D. J. DAVIS, H. G. DORSEY, O. W. TORRESON

*Committee on Monographs* (W. N. FENTON, chairman):  
 To January 1953..... R. W. IMLAY, P. W. OMAN  
 To January 1954..... S. F. BLAKE, F. C. KRACEK  
 To January 1955..... W. N. FENTON, ALAN STONE

*Committee on Awards for Scientific Achievement* (J. R. SWALLEN, general chairman):  
*For Biological Sciences*..... J. R. SWALLEN (chairman), L. M. HUTCHINS,  
 MARGARET PITTMAN, F. W. POOS, L. P. SCHULTZ

*For Engineering Sciences*..... R. C. DUNCAN (chairman), A. C. FIELDNER,  
 WAYNE C. HALL, J. W. MCBURNEY, O. S. READING, H. L. WHITTEMORE

*For Physical Sciences*..... L. A. WOOD (chairman), P. H. ABELSON,  
 F. S. DAFT, GEORGE W. IRVING, JR., J. H. McMILLEN

*For Teaching of Science*..... M. A. MASON (chairman), F. E. FOX, M. H. MARTIN

*Committee on Grants-in-aid for Research*..... L. E. YOCUM (chairman), H. N. EATON,  
 K. F. HERZFELD

*Committee on Policy and Planning:*  
 To January 1953..... W. A. DAYTON (chairman), N. R. SMITH  
 To January 1954..... H. B. COLLINS, JR., W. W. RUBEY  
 To January 1955..... L. W. PARR, F. B. SILSBEE

*Committee on Encouragement of Science Talent* (A. T. MCPHERSON, chairman):  
 To January 1953..... A. H. CLARK, F. L. MOHLER  
 To January 1954..... J. M. CALDWELL, W. L. SCHMITT  
 To January 1955..... A. T. MCPHERSON, W. T. READ

*Representative on Council of A. A. A. S.*..... F. M. SETZLER

*Committee of Auditors*..... C. L. GAZIN (chairman), LOUISE M. RUSSELL, D. R. TATE

*Committee of Tellers*... GEORGE P. WALTON (chairman), GEORGE H. COONS, C. L. GARNER

## CONTENTS

	Page
ANTHROPOLOGY.—Some applications of physical anthropology. ROBERT M. WHITE.....	65
GEOLOGY.—Paleozoic of western Nevada. H. G. FERGUSON.....	72
PALEONTOLOGY.—Some new species of crinoids from the Henryhouse formation of Oklahoma. HARRELL L. STRIMPLE.....	75
PALEONTOLOGY.— <i>Cribrotextularia</i> , a new foraminiferal genus from the Eocene of Florida. ALFRED R. LOEBLICH, JR., and HELEN TAPPAN	79
ZOOLOGY.— <i>Ammopemphix</i> , new name for the Recent foraminiferal genus <i>Urnula</i> Wiesner. ALFRED R. LOEBLICH, JR.....	82
ZOOLOGY.—A new <i>Calyptrophora</i> (Coelenterata: Octocorallia) from the Philippine Islands. FREDERICK M. BAYER.....	82
ICHTHYOLOGY.—Eight new fishes from the Gulf coast of the United States, with two new genera and notes on geographic distribution. ISAAC GINSBURG.....	84
MAMMALOLOGY.—A new <i>Clyomys</i> from Paraguay (Rodentia: Echimyidae). JOÃO MOOJEN.....	102
ORNITHOLOGY.—A new finch from northern Perú. JOHN T. ZIMMER...	103
OBITUARY: Merrill Bernard.....	104

# JOURNAL

OF THE

# WASHINGTON ACADEMY OF SCIENCES

BOARD OF EDITORS

WILLIAM F. FOSHAG  
U.S. NATIONAL MUSEUM

J. P. E. MORRISON  
U.S. NATIONAL MUSEUM

JOHN C. EWERS  
U.S. NATIONAL MUSEUM

ASSOCIATE EDITORS

F. A. CHACE, JR.  
BIOLOGY

J. I. HOFFMAN  
CHEMISTRY

T. P. THAYER  
GEOLOGY

MIRIAM L. BOMHARD  
BOTANY

R. K. COOK  
PHYSICS AND MATHEMATICS

PHILIP DRUCKER  
ANTHROPOLOGY

C. W. SABROSKY  
ENTOMOLOGY

PUBLISHED MONTHLY  
BY THE

WASHINGTON ACADEMY OF SCIENCES  
MOUNT ROYAL & GUILFORD AVES.  
BALTIMORE, MARYLAND

Entered as second class matter under the Act of August 24, 1912, at Baltimore, Md.  
Acceptance for mailing at a special rate of postage provided for in the Act of February 28, 1925  
Authorized February 17, 1949

## Journal of the Washington Academy of Sciences

This JOURNAL, the official organ of the Washington Academy of Sciences, publishes: (1) Short original papers, written or communicated by members of the Academy; (2) proceedings and programs of meetings of the Academy and affiliated societies; (3) notes of events connected with the scientific life of Washington. The JOURNAL is issued monthly. Volumes correspond to calendar years.

*Manuscripts* may be sent to any member of the Board of Editors. It is urgently requested that contributors consult the latest numbers of the JOURNAL and conform their manuscripts to the usage found there as regards arrangement of title, subheads, synonymies, footnotes, tables, bibliography, legends for illustrations, and other matter. Manuscripts should be typewritten, double-spaced, on good paper. Footnotes should be numbered serially in pencil and submitted on a separate sheet. The editors do not assume responsibility for the ideas expressed by the author, nor can they undertake to correct other than obvious minor errors.

*Illustrations* in excess of the equivalent (in cost) of one full-page halftone are to be paid for by the author.

*Proof.*—In order to facilitate prompt publication one proof will generally be sent to authors in or near Washington. It is urged that manuscript be submitted in final form; the editors will exercise due care in seeing that copy is followed.

*Unusual cost* of foreign, mathematical, and tabular material, as well as alterations made in the proof by the author, may be charged to the author.

*Author's Reprints.*—Reprints will be furnished in accordance with the following schedule of prices (approximate):

Copies	4 pp.	8 pp.	12 pp.	16 pp.	20 pp.	Covers
100	\$3.25	\$6.50	\$ 9.75	\$13.00	\$16.25	\$3.00
200	6.50	13.00	19.50	26.00	32.50	6.00
300	9.75	19.50	29.25	39.00	48.75	9.00
400	13.00	26.00	39.00	52.00	65.00	12.00

*Subscriptions* or requests for the purchase of back numbers or volumes of the JOURNAL or the PROCEEDINGS should be sent to HAROLD A. REHDER, Custodian and Subscription Manager of Publications, U. S. National Museum, Washington 25, D. C.

*Subscription Rates* for the JOURNAL.—Per year..... \$7.50

Price of back numbers and volumes:	Per Vol.	Per Number
Vol. 1 to vol. 10, incl.—not available.*	—	—
Vol. 11 to vol. 15, incl. (21 numbers per vol.)	\$10.00	\$0.70
Vol. 16 to vol. 22, incl. (21 numbers per vol.)	8.00	0.60
Vol. 23 to current vol. (12 numbers per vol.)	7.50	0.90

\* Limited number of complete sets of the JOURNAL (vol. 1 to vol. 41, incl.) available for sale to libraries at \$348.50.

MONOGRAPH No. 1, "The Parasitic Cuckoos of Africa," by Herbert Friedmann. \$4.50

PROCEEDINGS, vols. 1-13 (1899-1911) complete..... \$25.00

Single volumes, unbound..... 2.00

Single numbers..... .25

*Missing Numbers* will be replaced without charge provided that claim is made to the Treasurer within 30 days after date of following issue.

*Remittances* should be made payable to "Washington Academy of Sciences" and addressed to the Treasurer, H. S. RAPPLEYE, 6712 Fourth Street, N.W., Washington 12, D.C.

*Exchanges.*—The Academy does not exchange its publications for those of other societies.



# JOURNAL

## OF THE

# WASHINGTON ACADEMY OF SCIENCES

VOLUME 42

April 1952

No. 4

METEOROLOGY.—*On the variation of the average daily temperature at Washington,*  
D. C. RICHMOND T. ZOCH.

The long-period averages of temperature, the "normals," have been computed for Washington by numerous persons since continuous records were made here. The object of having a normal daily temperature is to make an estimate of the temperature for each day. The temperature on the same day for different years varies considerably; and as no paper has been published showing how variable this daily temperature can be, this paper has been prepared.

The standard deviations and the extremes for each day of the year, derived from a 60-year period of record, have been computed and are shown in a table.

Finally, it is pointed out that while there is no diurnal variation in the normal daily temperature, there is a definite diurnal variation in the standard deviation of the average daily temperature, and this has a bearing on the long standing question of the reality of singularities.

#### COMPUTING THE STANDARD DEVIATION

One of the most obvious facts of meteorology is that there is a diurnal variation in the temperature of the air. Another obvious fact is that there is an annual variation in the air temperature; this latter variation is usually referred to as the annual march of temperature. In making studies of the nature of the annual variation it is sometimes useful and convenient first to eliminate the diurnal variation. In the past, this has been done most often by taking the daily maximum and daily minimum temperatures, adding them together and dividing their sum by two. This is the method used by C. F. Marvin when he compiled Monthly Weather Review Supplement No. 25, which contains daily normal temperatures for each

of the principal cities in the United States including Washington. Other methods of computing the average daily temperature have also been used and the reader who is interested in them should refer to Bulletin S of the U. S. Weather Bureau. The method used in this study was to take the twenty-four hourly readings of the temperature for each day, add them and divide the sum by 24.

The temperature observations used in this study were all made by the U. S. Weather Bureau at its central office located on the southwest corner of twenty fourth and M Streets, N.W. A continuous record of temperature has been maintained there since March 1889 by means of a thermograph, and this thermograph has been regularly checked with standard as well as maximum and minimum thermometers. From the thermograph traces hourly readings of temperature have been extracted. The Weather Bureau computed daily averages from the 24 hourly readings from the beginning of this record through 1942. The averages for the years 1943 through (March) 1949 were specially computed for this study.

It is worth pointing out that the record of temperature at twenty fourth and M Streets, N.W., maintained by the Weather Bureau is the longest record of temperature for any location in the District of Columbia. The record used for this study was exactly 60 years (to the nearest whole day) and commenced with the day after the vernal equinox in 1889 and ended on the day of the vernal equinox in 1949, and this period comprises 21,914 days. The date of the vernal equinox in both 1889 and 1949 was March 20 although prior to 1900 it was most

often March 20, and after 1900 it was usually on March 21.

The average temperature for these 21,914 days was arranged into 366 arrays, one array for each day, the arrays so placed that both the vernal equinox and the autumnal equinox of each year were always in the same array. These two days are near the times of the year when the annual march of temperature is rising or falling most rapidly, respectively. As the time from the vernal equinox to the autumnal equinox during these years was approximately 186 days 10 hours and from the autumnal equinox to the vernal equinox approximately 178 days 20 hours, there were 186 arrays with 60 days each beginning with the vernal equinox prior to the autumnal equinox and 178 arrays with 60 days each beginning with the autumnal equinox prior to the vernal equinox. These 364 arrays thus accounted for 21,840 days. The remaining 74 days were placed in two arrays, one about January 20 with 49 days and the other about July 22 with 25 days.

After the average daily temperatures were placed in these 366 arrays several statistical parameters were obtained for each array. First the arithmetic mean was computed for each array, and secondly the standard deviation. Next, a frequency distribution for each array was made and the extremes (lowest average daily temperature and highest average daily temperature, *not* the absolute maximum and absolute minimum), the upper and lower quartiles and the median of each array were obtained. Table 1 shows these standard deviations and extremes. The arithmetic means, quartiles, and medians are not given in this paper.

Table 2 summarizes, or smoothes, the data shown in Table 1. Here the day to day fluctuations are ironed out and one can see at a glance how the standard deviations and extremes of the average daily temperatures change during the year. Table 2 also shows the smoothed averages of the daily arithmetic means which were omitted from Table 1. The standard deviation is greatest in winter and least in summer. Table 2 is intended only to show roughly the annual variation.

#### THE DIURNAL VARIATION OF THE STANDARD DEVIATION

The question naturally arises, in making these analyses of temperature, when is the best, or most logical, time to begin the "day," the 24-hour period. No answer is given to this question in this article but a few comparisons were made and the results of these will be shown.

The U. S. Weather Bureau, in computing the average daily temperature from the 24 hourly readings, quite naturally used the civil day, when the end of one "day" and the beginning of the next occurs at midnight. There is no *a priori* reason for assuming this to be the most logical time. The most careful or thorough way to investigate this would be to begin the "day" with each one of the 24 hours. Then, instead of having 21,914 average daily temperatures for this 60 year period of record there would be 24 times 21,914 or 525,936 average daily temperatures to be placed in 24 sets of 366 arrays and then 24 sets of 366 arithmetic means, standard deviations, extremes, quartiles and medians to be computed or derived. Clearly, to do this task in such a thorough manner is a machine job, and it was not possible for the present writer to undertake it. To make some investigation it was decided to use a "day" for which the end of one 24-hour period and the beginning of the next occurs at noon. This additional investigation would mean one additional set of 366 arrays, and to proceed it would first be necessary to compute 21,914 new average daily temperatures. Even this was too large an undertaking by hand methods so this investigation was confined to a 31-day period, the 31 days following the vernal equinox.

First, 1860 average daily temperatures were computed where the end of one 24-hour period and the beginning of the next was at noon. Then these 1860 average daily temperatures were arranged into 31 arrays with 60 temperatures in each array; finally the arithmetic means and the standard deviations were computed and the extremes obtained for each of these 31 arrays. These results are shown in Tables 3 and 4.

TABLE I.—STANDARD DEVIATIONS AND EXTREMES FOR EACH DAY OF THE YEAR

Day after vernal equinox	Lowest temperature °F	Year of occurrence	Standard deviation °F	Highest temperature °F	Year of occurrence	Usual calendar date	Day after vernal equinox	Lowest temperature °F	Year of occurrence	Standard deviation °F	Highest temperature °F	Year of occurrence	Usual calendar date
<i>Mar.</i>							<i>May</i>						
1	30.4	1914	10.61	74.8	1948	21	52	49.0	1907	6.44	81.2	1896	11
2	21.5	1934	10.63	75.6	1948	22	53	49.5	1939	7.02	79.2	1896	12
3	23.8	1906	9.17	67.0	1929	23	54	50.2	1895	6.59	75.3	1908	13
4	26.0	1940	9.06	71.8	1939	24	55	49.7	1895	6.44	77.7	1940	14
5	26.7	1940	9.52	68.7	1939	25	56	49.7	1895	7.05	78.1	1900	15
6	29.9	1894	9.76	71.8	1921	26	57	49.1	1895	6.40	77.0	1944	16
7	27.0	1894	10.00	74.1	1921	27	58	52.1	1891	6.13	79.3	1911	17
8	29.8	1923	9.72	72.1	1907	28	59	52.9	1895	6.15	81.8	1911	18
9	34.0	1893	8.94	72.5	1945	29	60	54.8	1915	6.03	80.4	1911	19
10	26.2	1923	8.24	70.8	1945	30	61	50.3	1929	6.82	78.4	1898	20
11	25.9	1923	8.17	65.6	1945	31	62	49.8	1895	6.53	80.8	1911	21
<i>Apr.</i>							<i>June</i>						
12	31.8	1924	9.18	71.2	1917	1	63	52.1	1895	7.54	82.1	1941	22
13	34.9	1911	8.26	69.5	1903	2	64	53.4	1889	6.05	80.4	1925	23
14	35.4	1908	8.59	70.7	1913	3	65	53.2	1907	6.11	77.9	1946	24
15	35.0	1896	8.98	69.3	1910	4	66	47.7	1925	6.06	78.6	1918	25
16	34.1	1944	7.61	74.5	1942	5	67	52.7	1925	6.53	78.8	1914	26
17	35.5	1898	8.53	75.0	1942	6	68	53.3	1902	6.99	83.9	1941	27
18	38.4	1935	8.40	77.5	1929	7	69	55.8	1891	6.68	83.8	1941	28
19	35.1	1916	7.55	76.7	1929	8	70	54.6	1915	6.60	79.6	1939	29
20	34.0	1917	8.83	77.6	1922	9	71	55.2	1910	6.50	82.6	1895	30
21	34.3	1918	8.79	73.9	1922	10	72	52.8	1907	6.40	84.3	1895	31
22	34.9	1894	7.62	72.2	1947	11	<i>July</i>						
23	39.5	1894	7.21	69.6	1948	12	73	50.8	1907	6.40	85.7	1895	1
24	34.7	1940	8.05	72.4	1945	13	74	54.2	1915	6.99	86.7	1895	2
25	36.8	1923	8.80	74.8	1941	14	75	54.4	1929	6.63	85.2	1895	3
26	35.8	1935	8.24	75.1	1941	15	76	52.7	1926	6.57	84.8	1943	4
27	38.8	1905	7.71	72.6	1941	16	77	54.8	1945	6.84	84.7	1925	5
28	38.6	1926	8.14	73.5	1896	17	78	51.7	1894	6.83	85.7	1925	6
29	37.6	1926	8.87	78.4	1896	18	79	54.7	1891	6.37	84.6	1899	7
30	41.6	1890	8.72	79.8	1896	19	80	54.8	1913	6.32	83.6	1899	8
31	38.0	1897	8.95	80.9	1941	20	81	57.9	1913	5.96	86.7	1933	9
32	42.2	1922	8.10	74.9	1896	21	82	51.8	1907	6.56	85.4	1911	10
33	42.2	1930	8.12	76.7	1902	22	<i>August</i>						
34	40.9	1930	7.97	71.6	1915	23	83	55.5	1907	6.23	84.9	1947	11
35	39.5	1919	7.58	77.2	1925	24	84	55.8	1907	5.90	81.5	1933	12
36	44.4	1919	7.41	75.8	1915	25	85	57.7	1907	5.43	80.7	1944	13
37	45.8	1892	7.49	76.4	1915	26	86	56.3	1933	5.43	82.9	1945	14
38	43.2	1928	7.39	74.7	1938	27	87	58.1	1901	6.08	84.2	1945	15
39	37.8	1898	6.69	69.6	1938	28	88	58.9	1917	5.99	84.5	1945	16
40	48.3	1925	6.60	74.6	1942	29	89	59.8	1900	5.56	83.8	1945	17
41	45.1	1912	7.10	77.5	1942	30	90	62.5	1946	4.80	84.6	1944	18
<i>May</i>							91	62.9	1912	5.17	85.4	1931	19
42	47.8	1908	6.86	75.5	1930	1	92	64.0	1920	5.23	85.2	1934	20
43	49.5	1911	6.74	76.6	1942	2	93	61.2	1940	5.26	83.5	1941	21
44	46.1	1946	7.32	75.2	1919	3	<i>September</i>						
45	46.5	1917	7.32	74.9	1944	4	94	59.7	1918	5.65	84.3	1943	22
46	44.2	1917	7.69	75.2	1918	5	95	61.7	1936	5.81	84.0	1914	23
47	45.1	1891	8.37	79.2	1930	6	96	57.0	1936	5.69	85.8	1943	24
48	46.5	1947	7.12	77.1	1930	7	97	63.0	1918	4.83	85.1	1943	25
49	44.5	1947	7.42	77.4	1930	8	98	64.3	1896	4.73	84.7	1943	26
50	46.6	1906	7.32	78.9	1936	9	99	62.6	1893	5.13	83.8	1913	27
51	47.1	1913	7.28	78.6	1911	10	100	62.8	1919	5.07	87.5	1934	28
							101	61.5	1893	5.36	86.0	1945	29
							102	67.2	1943	5.16	89.3	1901	30

TABLE 1.—Continued

Day after vernal equinox	Lowest temperature °F	Year of occurrence	Standard deviation °F	Highest temperature °F	Year of occurrence	Usual calendar date	Day after vernal equinox	Lowest temperature °F	Year of occurrence	Standard deviation °F	Highest temperature °F	Year of occurrence	Usual calendar date
<i>July</i>							<i>July</i>						
103	66.6	1940	5.50	88.0	1933	1	114	66.7	1898	4.57	85.2	1944	12
104	65.8	1891	4.66	87.9	1898	2	115	66.4	1926	4.35	85.2	1942	13
108	60.9	1933	5.32	88.5	1898	3	116	62.5	1926	4.73	85.5	1934	14
106	63.5	1940	5.30	86.2	1911	4	117	67.2	1903	4.36	84.8	1936	15
107	66.0	1909	4.74	86.5	1911	5	118	68.0	1929	3.98	84.3	1942	16
108	66.2	1892	4.52	86.5	1934	6							
109	65.4	1918	4.28	85.7	1925	7	119	65.8	1910	5.04	86.8	1900	17
110	60.5	1891	4.81	86.2	1890	8	120	65.8	1892	4.74	88.0	1942	18
111	64.2	1891	5.00	87.4	1936	9	121	68.7	1939	4.62	89.9	1930	19
112	65.9	1890	4.79	89.9	1936	10	122	65.3	1890	5.20	90.0	1930	20
113	63.3	1895	4.79	86.0	1935	11	123	66.3	1890	4.63	87.6	1926	21
							124	68.1	1904	3.65	83.2	1899	22
Day before autumnal equinox	Lowest temperature °F	Year of occurrence	Standard deviation °F	Highest temperature °F	Year of occurrence	Usual calendar date	Day before autumnal equinox	Lowest temperature °F	Year of occurrence	Standard deviation °F	Highest temperature °F	Year of occurrence	Usual calendar date
<i>July</i>							<i>Aug.</i>						
62	67.4	1947	4.20	84.6	1914	23	31	60.5	1931	4.75	84.2	1936	23
61	66.4	1912	4.46	84.3	1935	24	30	60.7	1890	5.07	84.4	1903	24
60	66.5	1904	4.22	85.0	1930	25	29	59.8	1890	5.38	84.0	1947	25
59	64.0	1920	4.95	88.0	1930	26	28	59.2	1908	5.52	84.0	1900	26
58	65.5	1920	5.14	88.9	1930	27	27	59.3	1927	5.41	85.1	1948	27
57	68.3	1895	4.74	88.0	1940	28	26	60.3	1915	5.42	86.0	1948	28
56	67.8	1914	3.98	86.2	1901	29	25	58.7	1891	5.59	86.0	1948	29
55	63.0	1914	4.49	85.0	1931	30	24	60.8	1911	5.24	83.2	1948	30
54	64.1	1903	5.22	87.5	1917	31	23	61.2	1911	5.50	85.8	1932	31
							<i>Sept.</i>						
53	66.4	1895	4.70	87.4	1933	1	22	61.4	1890	5.63	86.5	1932	1
52	67.2	1920	4.42	84.3	1926	2	21	60.0	1893	5.91	83.2	1898	2
51	62.9	1921	4.90	86.3	1931	3	20	61.2	1892	5.76	82.4	1898	3
50	64.2	1912	4.68	87.4	1930	4	19	62.7	1893	4.81	83.7	1898	4
49	64.1	1912	5.31	88.5	1930	5	18	60.0	1928	4.89	82.1	1944	5
48	65.5	1912	4.65	91.3	1918	6	17	57.2	1928	5.88	83.0	1900	6
47	66.9	1948	4.75	87.3	1918	7	16	59.2	1924	6.32	82.7	1898	7
46	68.6	1942	4.43	87.0	1930	8	15	57.9	1918	5.93	86.2	1939	8
45	65.0	1897	4.99	88.0	1930	9	14	57.8	1914	6.20	82.2	1933	9
44	67.6	1927	4.05	87.7	1896	10	13	54.7	1924	6.98	83.7	1941	10
43	67.1	1931	4.32	86.3	1900	11	12	51.1	1917	6.90	83.7	1900	11
42	60.7	1928	5.43	86.7	1926	12	11	56.7	1917	6.08	83.0	1895	12
41	65.7	1941	5.70	85.1	1896	13	10	58.2	1911	5.73	81.4	1931	13
40	66.4	1902	5.01	86.0	1943	14	9	55.6	1913	6.63	82.6	1915	14
39	65.1	1899	4.59	84.7	1938	15	8	56.0	1895	5.57	82.6	1930	15
38	66.9	1921	4.14	85.0	1938	16	7	55.8	1923	6.10	79.9	1942	16
37	64.2	1923	4.46	83.1	1944	17	6	57.8	1903	6.00	79.2	1915	17
36	63.8	1915	4.60	83.0	1944	18	5	56.9	1937	5.89	79.8	1921	18
35	65.0	1905	4.12	84.4	1937	19	4	52.6	1916	6.23	80.3	1942	19
34	63.0	1926	4.56	85.0	1937	20	3	54.5	1929	6.34	80.7	1895	20
33	62.7	1926	4.92	84.0	1937	21	2	51.9	1918	5.19	81.9	1931	21
32	62.2	1931	4.98	84.6	1916	22	1	47.4	1904	7.58	84.1	1931	22

TABLE 1.—Continued

Day after autumnal equinox	Lowest temperature °F	Year of occurrence	Standard deviation °F	Highest temperature °F	Year of occurrence	Usual calendar date	Day after autumnal equinox	Lowest temperature °F	Year of occurrence	Standard deviation °F	Highest temperature °F	Year of occurrence	Usual calendar date
<i>Sept.</i>							<i>Nov.</i>						
0	50.0	1904	7.08	82.2	1895	23	50	33.6	1926	7.76	67.1	1935	12
1	50.8	1896	6.91	79.0	1926	24	51	26.4	1911	8.09	62.8	1931	13
2	51.5	1928	7.00	80.9	1930	25	52	30.3	1905	7.14	63.6	1929	14
3	49.7	1928	7.09	82.5	1930	26	53	27.1	1933	8.22	62.8	1926	15
4	49.4	1940	7.22	78.7	1900	27	54	23.8	1933	8.26	64.5	1927	16
5	50.9	1942	6.92	77.2	1945	28	55	29.5	1924	8.88	66.0	1930	17
6	50.1	1942	6.46	76.1	1945	29	56	26.8	1891	9.71	70.6	1928	18
7	48.8	1899	6.69	75.8	1927	30	57	28.4	1936	9.03	66.7	1921	19
<i>Oct.</i>							58	31.4	1901	8.36	65.8	1931	20
8	44.5	1899	6.72	78.4	1927	1	59	30.6	1937	8.60	68.7	1900	21
9	46.4	1899	6.13	76.2	1927	2	60	31.0	1929	8.35	63.2	1931	22
10	45.9	1899	6.21	74.2	1941	3	61	30.1	1929	7.36	63.7	1940	23
11	49.2	1901	7.51	80.9	1941	4	62	29.1	1938	6.85	61.8	1927	24
12	49.8	1901	7.23	82.8	1941	5	63	25.8	1903	7.18	57.5	1905	25
13	42.4	1935	7.71	82.5	1941	6	64	24.9	1903	8.40	64.4	1946	26
14	43.9	1904	7.78	83.3	1941	7	65	24.8	1932	9.01	60.8	1927	27
15	46.1	1889	7.19	76.1	1941	8	66	20.1	1930	8.61	66.5	1896	28
16	43.2	1917	7.40	75.5	1939	9	67	25.9	1891	8.23	62.0	1896	29
17	41.8	1925	7.82	76.6	1939	10	68	18.0	1929	9.27	64.4	1927	30
18	41.5	1906	6.94	74.6	1919	11	<i>Dec.</i>						
19	42.0	1906	6.31	73.6	1912	12	69	23.8	1936	7.76	62.2	1908	1
20	43.2	1934	5.82	72.0	1928	13	70	22.8	1930	7.07	54.9	1921	2
21	44.5	1934	6.52	69.6	1941	14	71	23.5	1896	7.51	55.2	1914	3
22	42.6	1937	6.99	70.2	1915	15	72	24.4	1896	8.12	53.3	1933	4
23	43.9	1937	6.92	72.2	1919	16	73	22.7	1926	8.43	59.7	1916	5
24	46.3	1900	6.98	74.4	1928	17	74	22.1	1901	7.29	59.5	1912	6
25	44.7	1901	6.89	72.8	1928	18	75	26.5	1893	6.64	56.0	1932	7
26	44.7	1948	6.77	70.9	1947	19	76	25.3	1910	6.89	57.1	1924	8
27	38.5	1940	7.28	70.5	1916	20	77	21.1	1927	9.12	56.0	1923	9
28	37.2	1940	7.34	68.6	1941	21	78	16.0	1917	8.55	55.6	1889	10
29	41.9	1925	7.48	71.4	1935	22	79	17.0	1917	8.53	55.0	1899	11
30	41.2	1907	6.85	70.2	1900	23	80	20.5	1904	8.55	59.8	1899	12
31	38.8	1889	6.13	69.5	1900	24	81	20.7	1895	8.99	58.6	1919	13
32	41.0	1889	6.53	66.0	1908	25	82	17.0	1904	9.54	62.7	1901	14
33	39.9	1933	6.83	67.3	1920	26	83	15.1	1914	9.04	54.9	1906	15
34	36.8	1936	7.44	70.5	1920	27	84	17.8	1916	9.30	51.6	1933	16
35	40.2	1936	7.17	71.4	1919	28	85	18.9	1932	7.81	54.5	1928	17
36	38.1	1925	7.69	72.4	1918	29	86	12.6	1919	8.80	55.8	1937	18
37	36.6	1925	7.45	69.8	1946	30	87	15.2	1919	8.67	57.8	1929	19
38	34.5	1917	7.91	72.4	1946	31	88	13.5	1942	7.62	58.2	1895	20
<i>Nov.</i>							89	14.8	1942	8.74	56.8	1923	21
39	37.9	1893	7.67	67.0	1919	1	90	18.4	1924	8.38	53.8	1923	22
40	37.2	1905	8.46	71.8	1929	2	91	21.0	1935	8.84	58.7	1891	23
41	36.3	1911	7.68	69.6	1936	3	92	18.3	1906	8.96	59.5	1891	24
42	38.1	1910	7.48	67.0	1936	4	93	19.2	1892	8.24	59.3	1932	25
43	35.9	1908	6.75	71.2	1935	5	94	12.5	1914	9.12	56.2	1895	26
44	35.8	1903	7.02	68.2	1938	6	95	14.0	1914	9.07	58.4	1889	27
45	34.0	1930	6.82	71.0	1948	7	96	18.9	1892	9.66	55.5	1936	28
46	38.5	1927	6.55	66.3	1943	8	97	7.3	1917	9.63	52.0	1910	29
47	37.9	1923	6.98	69.6	1895	9	98	2.7	1917	10.12	56.7	1940	30
48	35.2	1933	6.28	58.6	1935	10	99	7.2	1917	8.86	56.8	1898	31
49	32.2	1926	7.12	62.8	1935	11							

TABLE I.—Continued

Day after autumnal equinox	Lowest temperature °F	Year of occurrence	Standard deviation °F	Highest temperature °F	Year of occurrence	Usual calendar date	Day after autumnal equinox	Lowest temperature °F	Year of occurrence	Standard deviation °F	Highest temperature °F	Year of occurrence	Usual calendar date
<i>Jan.</i>							<i>Jan.</i>						
100	10.9	1918	8.77	57.6	1919	1	110	13.6	1893	8.68	53.6	1913	11
101	11.5	1904	9.87	56.6	1930	2	111	12.6	1893	8.26	50.6	1911	12
102	10.3	1918	9.31	51.5	1890	3	112	2.2	1912	10.04	65.6	1932	13
103	10.8	1904	9.58	51.3	1907	4	113	5.3	1912	11.04	60.2	1932	14
104	12.1	1896	10.34	57.2	1897	5	114	13.7	1893	11.05	65.0	1932	15
105	11.0	1912	9.89	60.9	1946	6	115	13.5	1912	8.70	56.9	1943	16
106	17.8	1912	9.74	62.4	1946	7	116	9.2	1893	9.29	59.5	1913	17
107	12.4	1942	8.06	57.5	1930	8	117	21.1	1904	9.94	56.8	1915	18
108	19.1	1942	9.74	63.2	1937	9	118	10.7	1893	9.98	56.5	1929	19
109	18.9	1942	7.71	54.7	1939	10	119	15.4	1940	8.65	52.6	1949	20
<i>Jan.</i>							<i>Feb.</i>						
59	13.0	1924	9.50	55.6	1890	21	29	20.1	1934	9.42	65.9	1939	20
58	16.7	1893	9.11	60.2	1906	22	28	12.1	1896	9.27	56.6	1943	21
57	8.5	1936	10.35	59.7	1906	23	27	17.1	1896	8.78	57.9	1913	22
56	11.5	1935	10.57	57.5	1933	24	26	19.5	1914	8.95	62.0	1922	23
55	14.0	1935	9.58	55.5	1909	25	25	11.9	1914	9.11	57.5	1943	24
54	11.7	1897	10.02	55.4	1916	26	24	14.5	1914	9.62	68.3	1930	25
53	14.1	1936	11.25	61.3	1916	27	23	14.6	1900	9.75	58.7	1930	26
52	12.1	1935	10.97	61.2	1916	28	22	12.8	1934	9.70	63.4	1890	27
51	10.2	1925	9.42	53.6	1947	29	21	15.8	1934	9.99	62.2	1903	28
50	11.2	1934	10.63	64.5	1947	30	20	25.0	1941	7.46	59.8	1910	29
49	15.4	1936	10.07	60.8	1916	31	<i>Mar.</i>						
<i>Feb.</i>							19	20.8	1914	7.24	59.0	1895	1
48	17.9	1936	7.23	48.4	1916	1	18	23.0	1891	7.88	64.5	1923	2
47	11.2	1900	8.89	51.5	1891	2	17	21.2	1925	9.05	63.9	1923	3
46	11.1	1905	9.58	51.0	1932	3	16	23.6	1926	8.40	62.0	1946	4
45	13.3	1905	9.53	54.0	1903	4	15	16.1	1901	9.84	63.5	1935	5
44	6.3	1918	9.44	55.4	1890	5	14	21.8	1920	9.13	64.9	1946	6
43	8.4	1917	9.92	58.9	1890	6	13	21.8	1932	8.80	66.0	1921	7
42	6.8	1895	9.01	55.3	1904	7	12	24.5	1932	7.98	68.2	1921	8
41	6.9	1895	8.10	49.2	1932	8	11	20.9	1932	7.28	63.7	1921	9
40	3.7	1934	9.72	52.6	1900	9	10	23.2	1932	8.02	58.8	1935	10
39	3.0	1899	9.78	53.0	1949	10	9	25.6	1914	8.56	63.1	1925	11
38	-3.2	1899	9.47	58.8	1925	11	8	22.0	1900	9.82	63.8	1890	12
37	.4	1899	10.04	60.0	1932	12	7	25.2	1896	9.01	63.8	1946	13
36	7.5	1899	10.28	54.0	1898	13	6	23.6	1896	9.41	65.5	1929	14
35	7.0	1899	10.21	56.0	1949	14	5	21.6	1911	9.44	65.1	1935	15
34	12.2	1943	9.98	62.0	1909	15	4	23.5	1916	11.46	72.2	1945	16
33	11.8	1904	10.25	65.0	1949	16	3	20.8	1900	10.78	69.1	1945	17
32	14.0	1904	9.63	60.2	1927	17	2	22.5	1941	9.63	64.5	1945	18
31	13.5	1896	8.36	66.8	1891	18	1	26.3	1914	9.66	66.9	1945	19
30	10.2	1903	10.44	59.4	1891	19	0	24.4	1914	10.61	73.6	1945	20

Table 3 shows the standard deviations for each array computed first from midnight-to-midnight average daily temperatures and then, in another column, from noon-to-noon temperatures. For the 31-day period considered the mean difference is  $0.421^{\circ}$  F. It is not believed advisable to apply the

usual statistical tests to find out whether this difference is significant because of the strong serial correlation due to the interrelationship between the values. Table 4 shows the extremes for each array derived first from midnight-to-midnight values and then from noon-to-noon values. For this 31-day period

the mean range between lowest and highest for midnight-to-midnight values is 40.1° F., while this range for noon-to-noon values is 40.8° F.

It is concluded that the variability of average daily temperature is greater when these daily averages are based on noon-to-noon values than when determined from midnight-to-midnight values. There is no reason for thinking that the midnight-to-midnight averages of temperature necessarily gives the minimum value for the standard deviation, nor is there any reason for concluding that the standard deviation computed from averages based on beginning and ending the day with noon is the maximum. Further research will be required to determine these maximum and minimum values of the standard deviation. However, the fact that there is a difference between the standard deviations computed from average daily temperatures based on midnight-to-midnight from those based on noon-to-noon demonstrates that maximum and minimum values of this standard deviation of temperature do exist.

Figures 1 and 2 depict the results of Table 3 graphically. Figure 1 shows the arithmetic means for 62 arrays all for the 31-day period following the vernal equinox. Likewise, Figure 2 shows the standard deviations. Figure 1 also shows the fairly well known fact that the annual march of

TABLE 2.—SUMMARY OF TABLE 1. MEAN VALUES OF EXTREMES AND STANDARD DEVIATIONS OF AVERAGE DAILY TEMPERATURE BY PERIODS (Temperatures are in °F.)

Period	Lowest	Highest	Arithmetic mean	Standard deviation	Duration of period, days
Mar. 21-Apr. 20.....	33.1	73.2	50.9	8.74	31
Apr. 21-May 21.....	46.8	77.0	61.6	7.08	31
May 22-June 21.....	55.5	83.4	70.0	6.19	31
June 22-July 22.....	64.3	86.6	75.9	4.87	30.42
July 23-Aug. 22.....	65.3	86.1	75.8	4.68	31
Aug. 23-Sept. 22....	57.7	83.1	70.9	5.82	31
Sept. 23-Oct. 22.....	45.5	76.0	60.3	6.98	30
Oct. 23-Nov. 21.....	34.5	67.7	49.7	7.56	30
Nov. 22-Dec. 21.....	21.4	58.6	39.2	8.21	30
Dec. 22-Jan. 20.....	12.8	57.2	35.1	9.31	29.82
Jan. 21-Feb. 19.....	10.0	57.2	34.2	9.71	30
Feb. 20-Mar. 20.....	20.5	63.9	40.8	9.14	30

TABLE 3.—COMPARISON OF STANDARD DEVIATIONS COMPUTED FROM MIDNIGHT-TO-MIDNIGHT AVERAGE DAILY TEMPERATURE WITH THOSE FROM NOON TO NOON

Day after vernal equinox	Midnight to midnight		Noon to noon	
	Arithmetic mean	Standard deviation	Arithmetic mean	Standard deviation
1	45.70	10.61	45.71	11.23
2	46.72	10.63	47.43	10.10
3	47.78	9.17	48.35	9.14
4	49.04	9.06	49.12	9.25
5	49.28	9.52	49.89	10.46
6	50.32	9.76	50.00	10.07
7	48.64	10.00	47.94	10.15
8	47.51	9.72	47.31	9.65
9	47.51	8.94	47.54	8.10
10	47.60	8.24	48.24	8.80
11	48.92	8.17	49.88	9.05
12	50.14	9.18	50.00	8.90
13	49.78	8.26	49.55	8.32
14	49.33	8.59	49.52	9.07
15	50.30	8.98	51.06	9.40
16	51.30	7.61	51.90	10.58
17	52.27	8.53	52.29	9.65
18	51.80	8.40	50.60	8.23
19	50.58	7.55	51.00	9.49
20	51.60	8.83	51.94	9.52
21	50.98	8.79	50.17	8.22
22	50.13	7.62	51.02	7.59
23	52.18	7.21	52.38	7.74
24	53.13	8.05	53.87	9.36
25	54.54	8.80	54.34	9.14
26	53.74	8.24	53.36	8.03
27	53.85	7.71	54.13	8.27
28	54.86	8.14	55.43	8.79
29	56.30	8.87	56.93	9.08
30	56.94	8.72	56.60	9.09
31	56.54	8.95	56.66	9.41
Means.....		8.737		9.158

temperature is not perfectly smooth. The high points such as the midnight-to-midnight value of the arithmetic mean (50.32) for the array dated March 26 and the low points such as the noon-to-noon value (47.31) for the array dated March 28 are technically referred to as "singularities" and have long been discussed by meteorologists and climatologists. C. F. Marvin held that these singularities were unreal, i.e., that there was no natural cause for them and that they were entirely the result of random sampling of the data. Other meteorologists have held these singularities to be real. The discussion of the reality of these singularities resolves itself into an

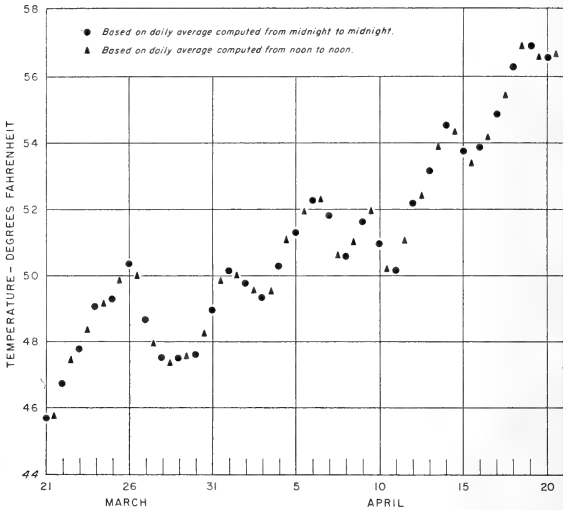

Fig. 1.—Observed average daily temperature: 60 years of record, 1889-1948, Washington, D. C. Twenty-fourth and M Streets, NW.

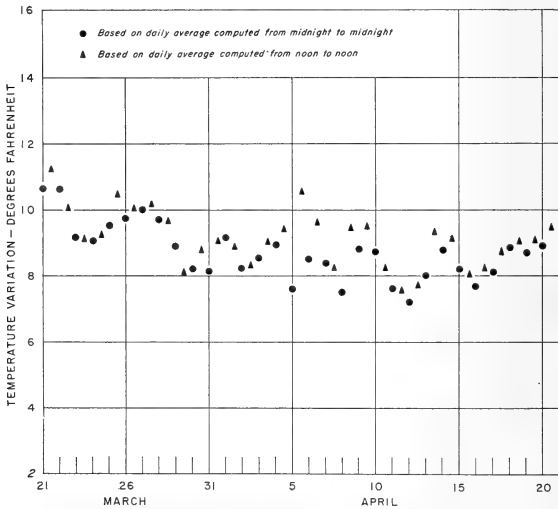

Fig. 2.—Observed daily standard deviation of temperature: 60 years of record, 1889-1948, Washington, D. C., Twenty-fourth and M Streets, NW.



TABLE 4.—COMPARISON OF EXTREMES DERIVED FROM MIDNIGHT-TO-MIDNIGHT AVERAGE DAILY TEMPERATURES WITH THOSE FROM NOON TO NOON

Day after vernal equinox	Lowest daily mean temperature				Highest daily mean temperature			
	Midnight to midnight		Noon to noon		Midnight to midnight		Noon to noon	
	°F	Year	°F	Year	°F	Year	°F	Year
1	30.4	1914	30.1	1896	74.8	1948	78.5	1948
2	21.5	1934	21.3	1934	75.6	1948	69.6	1948
3	23.8	1906	24.9	1906	67.0	1929	70.3	1939
4	26.0	1940	26.1	1896	71.8	1939	69.3	1913
5	26.7	1940	29.0	1896	68.7	1939	72.4	1939
6	29.9	1894	25.9	1894	71.8	1921	73.7	1921
7	27.0	1894	28.3	1923	74.1	1921	75.3	1921
8	29.8	1923	33.8	1904	72.1	1907	74.5	1907
9	34.0	1893	33.1	1941	72.5	1945	73.3	1945
10	26.2	1923	22.9	1923	70.8	1945	69.1	1945
11	25.9	1923	31.0	1919	65.6	1945	70.2	1917
12	31.8	1924	30.8	1924	71.2	1917	71.5	1917
13	34.9	1911	34.6	1911	69.5	1903	72.5	1913
14	35.4	1908	33.0	1903	70.7	1913	68.1	1945
15	35.0	1896	34.3	1944	69.3	1910	72.3	1910
16	34.1	1944	31.0	1898	74.5	1942	76.9	1942
17	35.5	1898	37.4	1898	75.0	1942	77.2	1929
18	38.4	1935	38.0	1935	77.5	1929	76.7	1929
19	35.1	1916	34.2	1916	76.7	1929	77.2	1929
20	34.0	1917	34.5	1909	77.6	1922	78.2	1922
21	34.3	1918	33.2	1918	73.9	1922	71.5	1947
22	34.9	1894	36.4	1894	72.2	1947	64.8	1889
23	39.5	1894	32.8	1940	69.6	1948	69.9	1922
24	34.7	1940	33.7	1923	72.4	1945	74.0	1945
25	36.8	1923	39.0	1943	74.8	1941	75.9	1941
26	35.8	1935	37.4	1928	75.1	1941	75.1	1941
27	38.8	1905	39.7	1904	72.6	1941	72.0	1941
28	38.6	1926	37.2	1926	73.5	1896	76.8	1896
29	37.6	1926	36.5	1926	78.4	1896	78.8	1896
30	41.6	1890	37.7	1904	79.8	1896	81.0	1896
31	38.0	1897	42.0	1947	80.9	1941	77.3	1896
Means . . . .	33.1		32.9		73.2		73.7	

investigation of the statistical reliability of the Arithmetic Mean, and this latter in turn is based on the value—or the estimate of the value—of the standard deviation. Besides showing the daily values of the standard deviation of average daily temperature (which have not been previously published for Washington) the object of this paper is to point out the uncertainty in the standard deviation due to this diurnal variation, a fact not previously emphasized by meteorologists and climatologists.

The question may be asked as to what is the cause of the diurnal variation in the

standard deviation of temperature. An explanation is offered here though it is not claimed that it is necessarily the correct one.

It is well known that the air is more stable at night time than during the day; or that vertical mixing and convection are more common during the day. In the latitude of Washington cold and warm air masses are continually passing. Now if the central part, the core so to speak, of a cold air mass passes during the middle of the afternoon, the time when vertical convection is greatest, the effect of the cold air mass is to an extent neutralized. If the central part of the cold air mass passes about sunrise, when the air is most likely to be stratified, its effect will be most pronounced. Hence it would seem that the coldest (lowest) 24 hour averages of temperature could be obtained by choosing the middle of the 24-hour period at sunrise. Also the overturning of a warm surface air mass is more likely to occur when vertical convection is great. And apparently if a warm surface air mass is not overturned (displaced by cold air) during the daylight hours of one day, the probability of its occurring during the night immediately following is sufficiently low to produce the observed diurnal variation in the standard deviation of temperature.

It would also appear reasonable to believe that the hours of the maximum and minimum in the diurnal variation of the standard deviation of temperature vary slightly during different times of the year.

*Acknowledgment.*—I appreciate very much the help and encouragement Dr. Helmut E. Landsberg has given me with this paper.

## REFERENCES

For the normal average daily temperature at Washington, D. C., the reader is referred to the *Climatic handbook for Washington, D. C.*, a publication of the U. S. Weather Bureau, Tables 29 and 30, both on page 44. Table 29 was computed by C. F. Marvin, while Table 30 was computed by John L. Baldwin. For an earlier determination of the Normal daily temperature see: *The daily normal temperature and the daily precipitation in the United States*, by Frank H. Bigelow, U. S. Weather Bureau, Bulletin R. 1908.

For discussions about the merits of different methods of computing the average daily temperature see: *Methods in climatology*, by V. Conrad and L. W. Pollak, 2d ed.: 155-164. 1950. Also *Report on*

the temperatures and vapor tensions in the United States, by Frank H. Bigelow, U. S. Weather Bureau, Bulletin S. 1909.

For singularities at Washington see: *Annual march of temperature at Washington, D. C.*, by G. Slocum, Bull. Amer. Meteorol. Soc. **22**: 220. 1941.

For the subject of singularities in general see: *Normal temperatures, daily, are irregularities in the annual march of temperature persistent*, by

Charles F. Marvin, Monthly Weather Rev. **47** (8): 544-555. 1919; *Literature concerning supposed recurrent irregularities in the annual march of temperature*, by C. Fitzhugh Talman, Monthly Weather Rev. **47**(8): 555-565. 1919; *Physical climatology*, by H. Landsberg, 1941, pp. 108-112; *Annual recurrences of weather: Singularities*, by C. E. P. Brooks, Weather (London) **1**(4/5): 106-113, and 130-134. 1946.

**GEOLOGY.**—*Brightseat formation, a new name for sediments of Paleocene age in Maryland.*<sup>1</sup> ROBERT R. BENNETT, U. S. Geological Survey, and GLENN GENE COLLINS, Maryland Department of Geology, Mines, and Water Resources. (Communicated by C. Wythe Cooke.)

Sediments of Paleocene age were considered to be absent in the coastal plain of Maryland until Cushman<sup>2</sup> concluded from his study of Foraminifera obtained from cores and cuttings from a deep oil-test well near Salisbury, Md., in the Eastern Shore area of Maryland, that beds of Paleocene age are present in the subsurface at that locality. Later, in connection with a study by Shifflett<sup>3</sup> of the Foraminifera in the sediments chiefly in the Western Shore area of Maryland, Cushman determined from the Foraminifera obtained from drill cuttings from a water well near Upper Marlboro (Prince Georges County), Md., that Paleocene sediments were present there in the subsurface.<sup>4</sup> Shifflett's study showed that, according to the foraminiferal content, Paleocene sediments are present in the subsurface in other parts of the Western and Eastern Shore areas of the Maryland Coastal Plain.

Additional studies made by the writers and others, in connection with the cooperative ground-water investigations in the Coastal Plain of Maryland by the U. S. Geological Survey and the Maryland De-

partment of Geology, Mines, and Water Resources, showed that this same section of sediments occurred at a shallow depth in some places in the western part of the Coastal Plain. This information indicated that this section of sediments might previously have been overlooked on the outcrop and had been mapped with either the overlying Aquia greensand (Eocene) or the underlying Monmouth formation (Upper Cretaceous).

Sections of sediments exposed in the general vicinity of Brightseat (Prince Georges County), Md. (see locations A, B, C, and D in Fig. 1), have a foraminiferal content and lithology similar to the subsurface section considered by Cushman and Shifflett to be of Paleocene age. A collection of megafossils from the exposed section at location A were studied by Dr. Julia Gardner, of the U. S. Geological Survey, who concluded that they probably represent a northern phase of the Paleocene.<sup>5</sup> Lithologic descriptions of the sections in the Brightseat area are as follows:

LOCATION A: 1 MILE WEST-SOUTHWEST OF BRIGHTSEAT AND 0.2 MILE SOUTH OF SHERIFF ROAD

Aquia greensand (Eocene):

Glauconitic sand and clay; contains black pebbles and black phosphatic nodules at the base; contact with underlying bed is abrupt and irregular. . . . . 2 ft. exposed

Brightseat formation (Paleocene):

Dark-gray micaceous sandy clay; contains megafossils; upper 1'6" contains, in part, material from overlying bed

8 ft. exposed

<sup>1</sup> Publication by permission of the Director, U. S. Geological Survey, and the Director of the Maryland Department of Geology, Mines, and Water Resources.

<sup>2</sup> CUSHMAN, JOSEPH A., *Foraminifera from the Hammond well. In "Cretaceous and Tertiary Subsurface Geology."* Maryland Dept. Geology, Mines, and Water Resources Bull. **2**: 226. 1948.

<sup>3</sup> SHIFFLETT, ELAINE, *Eocene stratigraphy and Foraminifera of the Aquia formation.* Maryland Dept. Geology, Mines, and Water Resources Bull. **3**. 1948.

<sup>4</sup> SHIFFLETT, *idem*, p. 1.

<sup>5</sup> Letter, May 8, 1951.

LOCATION C: EAST SIDE OF ADDISON ROAD 0.7  
MILE SOUTH OF CENTRAL AVENUE

Aquia greensand (Eocene):

Glauconitic clayey sand; weathers buff; large black pebbles (up to 1 inch in diameter) and black phosphatic nodules immediately above basal contact which is abrupt and irregular.....14 ft. exposed

Brightseat formation (Paleocene):

Light-gray micaceous sandy clay; fossiliferous; contains irregularly shaped masses of material from overlying bed.....1 ft. 3 in.

Indurated dark-gray silty clay; fossiliferous  
10 in.

Dark-gray silty clay; fossiliferous  
4 ft. exposed

LOCATION D: ABOUT 0.05 MILE WEST  
OF LOCATION C

Aquia greensand (Eocene):

Greenish-buff glauconitic sand; fossiliferous; basal contact is abrupt and irregular; black pebbles and phosphatic nodules occur immediately above contact.....4 ft. exposed

Brightseat formation (Paleocene):

Fine-textured dark-gray micaceous sandy clay; fossiliferous.....4 ft. exposed

The base of the Paleocene was seen only at location B about 1 mile southwest of Brightseat and 0.2 mile southeast of location A. There the contact with the underlying Monmouth formation of Upper Cretaceous age is abrupt but is even. The presence of a few large pebbles and reworked fossils immediately above the contact, and the abrupt contact itself, indicate an unconformable relation between these beds. The pebble zone, irregular contact, and lithologic contrast between the Eocene and Paleocene sediments at locations A, C, and D also indicate an unconformable relation.

The lithologic character of the Paleocene sediments and the underlying Monmouth formation is similar; however, if they are examined closely some differences can be detected. For example, the Monmouth formation contains a large amount of fragmental carbonaceous material, whereas in the Paleocene sediments it is scarce; moreover, the Paleocene sediments are

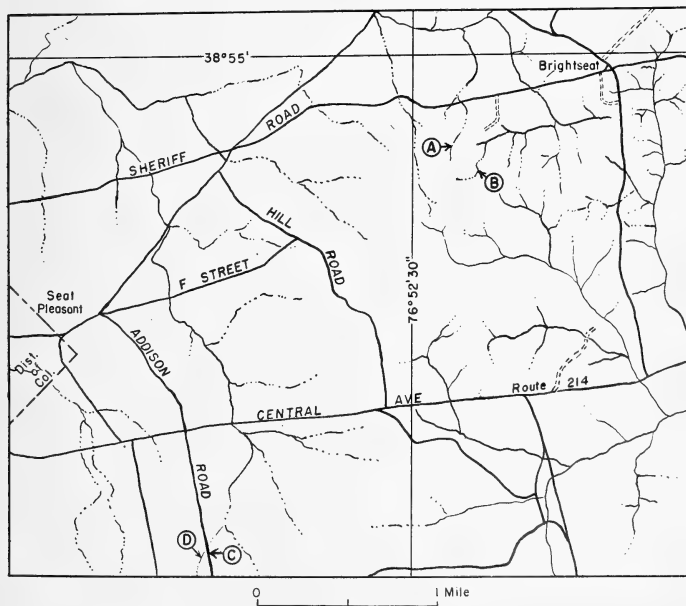

Fig. 1.—Map of Brightseat Area, Md., showing the locations of exposures of the Brightseat formation.

softer and do not have the tendency to break into large pieces or blocks as do the sediments in the Monmouth formation.

The thickness of the Paleocene sediments appears to be extremely variable in the outcrop area. Their thickness at locations A, C, and D probably is about 8 to 10 feet, but at other places along the line of outcrop Paleocene sediments are absent and the Aquia greensand directly overlies the Monmouth formation. For example, Paleocene sediments are absent in the first creek directly west of location A in Fig. 1.

Although the Paleocene sediments do not crop out as a continuous band, examination

of drill cuttings and Foraminifera from water wells shows that this unit occurs over a wide area in the subsurface in southern Maryland, where it commonly attains a thickness of 50 to 75 feet.

Inasmuch as this section of Paleocene sediments occurs over a large area, is unconformable with the Eocene and Cretaceous sediments, and constitutes a mappable unit, it seems desirable to give it formational rank. The name Brightseat formation is here proposed for this unit, and the exposure designated by location A in Fig. 1, 1 mile west-southwest of Brightseat, Md., is considered the type locality.

**PALEONTOLOGY.**—*Nomenclatural notes on carditids and lucinids.* A. CHAVAN, Thoiry (Ain), France. (Communicated by Julia Gardner.)

The revision<sup>1</sup> of several superfamilies, among which Carditacea and Lucinacea are, perhaps, the most puzzling and complex, led the writer to a re-examination of important nomenclatural points. Types of common genera, like *Cardita*, *Jagonia*, *Lucina*, or *Diplodonta* (*Taras* of most authors), are still under discussion, and conclusions according with the Rules are not universally accepted. The present paper deals with such problems and reviews, when necessary, points settled in the previous papers.

The conclusions here adopted not only follow the International Rules of Nomenclature in accepting the first unquestionable type-designation for a genus, and in rejecting those wrongly introduced, but they also succeed in saving well-known names, such as *Diplodonta*. It is, therefore, hoped that the International Commission of Zoological Nomenclature will soon place on the Official List the common names here discussed with the type species adopted in accordance with a strict interpretation of the Rules.

CARDITA, CARDITES,  
ARCINELLA, MYTILICARDIA

Two species are under discussion for the type of *Cardita* Bruguière, 1792 (Encycl. Method. 1: 401-413): *Cardita sulcata* Bruguière = *Chama*

<sup>1</sup> As a contribution to the "Treatise of Invertebrate Paleontology."

*antiquata* Linné and *Cardita calyculata* Bruguière = *Chama calyculata* Linné.

In 1799 Lamarck listed *C. calyculata* Linné under *Cardita*; however, according to the Rules, Lamarck's citations of 1799 are not designations, but only examples, as noted by Lamarck himself. In 1801, the same author cited the related species *variegata*, and this, again, is not a type-designation. In 1817, Schumacher distinguished two groups: the "cordiformes" ( $\alpha$ ) and the "trapeziformes" ( $\beta$ ), and cited *sulcata* and *calyculata* as representatives. The first real designation to be discussed is that of Schmidt (Versuch Conch. Samml.: 63. 1818) of *Chama calyculata* as the type of *Cardita* Lamarck, and of *antiquata* as the type of *Cardita* Megerle von Mühlfeld (who used *Cardita* in 1811 without selecting its type). But *Cardita* is of Bruguière, not of Lamarck or of Megerle von Mühlfeld; and as both these species are available for the type, Schmidt's designation of the two of them invalidates both (Stewart, R. B., Proc. Acad. Nat. Sci. Philadelphia, Spec. Publ. 3: 149. 1930). Winckworth (Proc. Malac. Soc. 26 (pt. 1): 23. 1944) has also pointed out that Schmidt's designations are referable only to the authors quoted by him.

Children's designation (Lamarck's *Genera of shells*: 43, pl. 6, fig. 60. 1822) of *Cardita antiquata* = *sulcata* is commonly accepted, and Stewart has recognized it, but Children's designations apply only to Lamarck's genera, so that *Chama antiquata* may be the designated type of *Cardita* Lamarck, but not *ipso facto* of *Cardita* Bruguière. Children makes no reference to Bruguière but

refers only to "Hist. Nat. des Animaux sans Vertèbres, 1802-1806," so that his selection is not applicable even to *Lucina* Lamarck of 1799 or of 1801.

The next designation was that by Anton (Verz. Conch.: 10. 1839) of *Cardita calyculata* Gmelin not of Bruguière as the type of *Cardita* "Lamarck, Desh." Gray (Proc. Zool. Soc. London 15: 193-194. 1847) was the first author to refer to *Cardita* Bruguière; he designated *Chama calyculata* as the type of *Cardita* Bruguière, 1789 (error for 1792), and also of *Cardita* Lamarck, 1801; *Cardita* Schumacher, 1817; and *Chama* sp. Linné.

*Cardita* Bruguière, 1792 (type by subsequent designation, Gray, 1847): *Chama calyculata* Linné is totally distinct from *Venericardia* Lamarck, while *Cardita* "Lamarck" corresponds partly to *Cardita* Bruguière and partly to *Cardita* Megerle von Mühlfeld, 1811 (type by subsequent designation, Schmidt, 1818): *C. antiquata* Linné, Schmidt's designation for *Cardita* Megerle von Mühlfeld, antedates that of Children for *Cardita* Lamarck, and applies to the same group. Both names are homonyms of *Cardita* and, therefore, synonyms of *Cardites* Link, 1807 (Besch. Rostock Samml.: 153) (type by monotypy): *Chama antiquata* Linné, the first valid name for this group, which is related subgenerically to *Venericardia* Lamarck, 1801.

*Arcinella* Oken, 1815 (Lehrb. Zool.: 238), type by subsequent designation, Stewart, 1930: *Chama calyculata* Linné is a synonym of *Cardita* Bruguière.

Authors like Schmidt and Gray not only designated a type or example, but also recognized, after Schumacher, that two groups were confused under the name *Cardita* and agreed in regarding the "trapeziformes" as typical and the "cordiformes" as atypical, so that the interpretation here offered is in total accord with the original meaning of *Cardita*.

*Chama sulcata* Solander, 1766, is a small *Venericardia* "s. l." (after Stewart) and does not invalidate *Cardita sulcata* Bruguière. Therefore *Cardita sulcata* Bruguière is a specific homonym, and this type species of *Cardites* must be named *Venericardia* (*Cardites*) *antiquata* (Lin.) pars = *sulcata* (Brug., non Sol.). *Antiquata* is a somewhat doubtful name, which has been reserved by Poli for the Mediterranean form.

"*Mytilicardia*" is the Latinization of a vernacular name, "les *Mytilicardes*", published in

Blainville (1824) with two examples: *Cardita crassicosta* and *C. calyculata*. Agassiz has cited it without species in the Latin form "*Mytilicardia*" (Nomenclator: 704. 1847). Herrmannsen's designation (Index 2: 85. 1847) of *Cardita jeson* Adanson (= *senegalensis* Reeve) accords with Blainville's view that "*Perna*" *jeson* was identical with *C. crassicosta* Lamarck. These species are, in fact, distinct, and "le *Jeson*" = *Cardita senegalensis* represents a subgenus of *Cardita* Bruguière with the anterior part of tooth 3b obliquely directed backwards: it has been designated the type of *Jesonina* Gray, 1840, by Gray 1847.

The earliest valid Latinization of "les *Mytilicardes*", and prior to that of Agassiz and Herrmannsen, is that of Anton, 1839 (*op. cit.*)<sup>2</sup> under the spelling "*Mytilicardita*." The type is *C. calyculata*, as quoted by Gray, 1847, so that *Mytilicardita* falls in the synonymy of *Cardita* Bruguière.

The usual spelling "*Mytilicardia*" Blainville is used in Tryon, 1872.

All the above cited uses intending to give a Latinization of the same vernacular term, and the first of them, *Mytilicardita*, being a synonym of *Cardita*, *Mytilocardia*, without species, has no status, and *Mytilicardia* falls also in the synonymy of *Cardita*, Herrmannsen's designation referring to a species which proves to be different from the two included in the original list. So that *Jesonina* Gray, n. n., according to Sherborn, is available for the *senegalensis* group, while *Actinobolus* "Klein" Möreh, 1853, of which the type is *C. sulcata* = *antiquata*, is to be listed in the synonymy of *Cardites*.

#### PSEUDOCARDIA, VETOCARDIA, VETERICARDIA

*Pseudocardia* Conrad, 1866 (Amer. Journ. Conch. 2: 103) was a heterogeneous unit, including true carditids, among them *Venericardia dupiniana* d'Orbigny and species of cardiid affinities, such as *Cardium haueri* Hoernes which is a Limnocardiid, and for that reason Fischer, 1887 (Manuel de Conchyliologie, p. 1039), placed *Pseudocardia* pars, in the synonymy of *Limnocardium*. Thirteen unlike species are listed by Conrad under *Pseudocardia*; the first one is cited as "*C. Smidti* Horn.", apparently an error for *Cardium schmidti* Hoernes.

Three years after, Conrad (*ibid.* 4: 246) re-

<sup>2</sup>The *C. calyculata* of both Anton and Gray seems to include more than one species.

placed *Pseudocardia* by *Vetocardia*, because of the prior use of *Pseudocardium* Gabb, 1866 (not 1869, as indicated in Neave). According to the present Rules, *Pseudocardium* does not invalidate *Pseudocardia*. This substitution of name in Conrad's paper (1868, publ. Feb. 4, 1869) is not accompanied by a citation of species, so that, in February 1869, *Vetocardia-Pseudocardia* was still a doubtful unit, ill-characterized and without type-designation.

But in July, 1869 (*ibid.* 5: 43) Conrad redefined his genus and cited under it a single species (p. 48), *Vetocardia crenalirata*, which was not included under *Pseudocardia* in 1866. In 1872 Conrad replaced *Vetocardia* because "this genus was improperly printed" by *Vetericardia* (Proc. Acad. Nat. Sci. Philadelphia 1872: 52) and cited two species, *V. crenalirata* and *V. dupiniana*.

Stoliczka, in his discussion of *Palaeocardita* on page 280, writes: "I believe that to this genus should be referred a great number of Cretaceous Carditacea of the type of *C. dupiniana* d'Orbigny." Before the introduction of *Vetericardia*, in 1872, but after the publication of the monotypic *Vetocardia* in 1869, Stoliczka (Cret. Fauna South Ind., *Pal. Ind.* 1871, Lamell, p. 283) discussed the affinities of *Pseudocardia-Vetocardia* and wrote "Conrad called some of the Cretaceous species at first *Pseudocardia* for which name he subsequently substituted *Vetocardia* as the type of which *Venericardia dupiniana* d'Orb. can fairly be taken."

Eames<sup>3</sup>, after Cox (Proc. Malac. Soc. London 27(1): 37. 1946), has recently accepted Stoliczka's statement as a valid designation, but I think it is a very questionable one.

First, such a "designation" is unusual in Stoliczka's work, for he clearly writes: "Type: . . ." when intending to designate a species. "Can fairly be taken," translated into French, appears to be more a suggestion than a selection. Stoliczka's English seems a little ambiguous and when translated into French is even more difficult to understand clearly, for on the same page Stoliczka writes that the genus has no significance, and is probably a synonym of *Palaeocardita*. It is evident that Stoliczka intended only to suggest, rather than to designate, a characteristic species while awaiting a restudy and careful comparisons of a difficult group.

Another very important argument is that

<sup>3</sup> EAMES, F. E., *A contribution to the study of the Eocene of western Pakistan*. Philos. Trans. Roy. Soc. London, ser. B, No. 627: 372. 1951.

Stoliczka overlooked the redefinition of *Vetocardia* and did not realize that its use with a single species not previously cited under *Pseudocardia* necessitated either the recognition of two distinct units, with a type to be selected for *Pseudocardia* and *crenalirata* for *Vetocardia* of July 1869; or, according to Conrad's indication that *Vetocardia* was a substitute, the selection of the species for which this term was used, its redefinition preventing the use of any of the very different forms cited in 1866. But Stoliczka's "designation," being common to two names, of which the former is heterogeneous and the latter, proposed "in replacement," but used for a single species not previously cited, cannot be accepted. No designation has yet been given for *Pseudocardia* or for *Vetocardia* (Eames only accepts Stoliczka's writing), but in 1941 Stephenson (Univ. Texas Publ., Bull. 4101: 175) designated "*Astarte crenalirata* Conrad" as the type of *Vetericardia* Conrad, 1872, and, according to the Rules, this applies *ipso facto* to *Vetocardia* of July 1869, used for the same species and mentioned by Stephenson. So that *Vetericardia* Conrad, 1872 (= *Vetocardia* Conrad, July, non February 1869), can validly be used with *Astarte crenalirata* as its type. It is impossible to design another species and to reject both *Vetericardia* and *Vetocardia* of July 1869 into the synonymy of *Pseudocardia*, since, despite Conrad's indication, they apply to a redefined unit, which was used for a single species, which was not listed either under *Pseudocardia* or *Vetocardia* of February 1869. But as *Pseudocardia* is totally heterogeneous and remains without selected type, for Stoliczka's "designation" applying to both names is valueless. I hereby designate "*Cardium Smidti*" Horn as the type of *Pseudocardia*, the first species listed by Conrad, 1866 (*op. cit.*).

In a recent paper<sup>4</sup>, I have proposed the genus *Ludbrookia* Chavan, 1951, type (o.d.): *Venericardia dupiniana* d'Orbigny, because this species is, in fact, quite distinct from the *Vetericardia* stock as well as from *Venericardia*, with which Eames unites it (as a "*Pseudocardia*"). This was, probably, more advisable than to replace Stoliczka's wrong "designation" by a correct one of the same species for *Pseudocardia* only; *dupiniana* having been listed not only under this

<sup>4</sup> CHAVAN, A., *Dénominations supraspécifiques de mollusques modifiées ou nouvelles*. C. R. somm. S. G. F., 1951: 210-212.

heterogeneous term, but in 1872 under *Vetericardia* also, together with *crenalirata*, and recently under *Venericardia* by Eames (as "type" by Stoliczka of *Pseudocardia*).

I wish to point out that *Vetocardia* having been used twice by Conrad before its replacement, it seems difficult to follow this author when he says he intended to correct only a misprint.

The type is known as *crenalirata* Conrad, 1860. However, in July 1861, Isaac Lea included it in a checklist under the name *Astarte crenulirata* Conrad.

#### LUCINA

In a previous paper<sup>5</sup> I have discussed in full the status of *Lucina* Bruguière, 1798, and have accepted *Venus jamaicensis* Spengler as its type, following a number of authors, but disagreeing with Stewart's interpretation (*op. cit.*: 175-178). In a recent paper, Eames (*op. cit.*: 382) does not refer to Stewart but accepts, like him, *Venus pennsylvanica* Chemnitz, a species belonging to the well-known *Linga* de Gregorio, 1885, which, therefore, would fall in the synonymy of *Lucina*. Curiously enough, although adopting the same conclusion, Eames refers to Schmidt's designation (1818) rejected by Stewart, who refers to Anton's paper of 1839, as the first unquestionable designation for *Lucina* Bruguière.

A short historical restudy will find easily what species has been clearly and correctly designated as the type of Bruguière's genus, prior to any other unambiguous designation, and in total accordance with the Rules.

*Lucina* appears in Bruguière's Encyclopedia (Encycl. Math., Tab. Vers, pl. 284-286) at the top of three plates of shells (and not of only plate 284, as quoted by Eames). According to the Rules, the identification of the species figures by Bruguière being possible—and having been done by Dillwyn, 1817—*Lucina* is "a genus with an indication" and not a *nomen nudum* (as I had myself admitted) so that a valid type-designation must refer to Bruguière, and not to a subsequent worker.

The first generic diagnosis of *Lucina* is by Lamarck (1799), who cites a species (*Venus edentula*) disagreeing with it. But it has been ruled that Lamarck's citations of 1799 are only

examples, as stated by himself—this one being inadequate—and not type-designations, so that *edentula* is fortunately not the monotype of a genus defined as having well-developed teeth. These conclusions are now generally accepted, and Eames has recently shown that *Anodontia* Link, 1807, was, as I had admitted, but in disagreement with Stewart's statement, the first valid generic name for "*Lucina*" *edentula* (see Gardner, 1951).

In 1801, Lamarck (Syst. Animaux sans Vert.: 124) gave a better example of *Lucina*, with *L. jamaicensis* as sole citation under this genus. After Lamarck, the meaning of such a citation is as follows: "Pour connaître d'une manière certaine les genres dont je donne ici les caractères, j'ai cité sous chacun d'eux une espèce connue ou très rarement, plusieurs." So that, although not a valid designation, this is a virtual one, giving, at least, Lamarck's choice in the selection of a typical form. Subsequent designations of *L. jamaicensis* by several authors, are therefore in total accordance with the original concept of the genus, while designations of *L. pennsylvanica* are not, this species having been excluded from the "Lucines" by Roissy (1805) and, apparently, by most revisers before the publication of Stewart's paper.

The first real type-designation is by Schumacher (1817), who selected *L. pennsylvanica*, but for *Lucina* Lamarck, without reference to Bruguière's work so that this designation has been rejected as not valid by Stewart and others.

The second one, accepted by Eames, is by Schmidt (1818), also *L. pennsylvanica*. Eames (*op. cit.*) accepted it on reference to Winckworth's opinion that Schmidt has really designated types for several genera, among them *Lucina*. But Winckworth has not discussed this particular designation, which is a questionable one, as pointed out by Stewart (*op. cit.*), who did not accept it. Although referring to Bruguière's genus, Schmidt has quoted plate 284 only (on which are several species figured) and, above all, he designated also *pennsylvanica* as the type of *Lucina* Lamarck, with an inexact reference to Chemnitz's figures of *jamaicensis*. Such a double and confused designation must be rejected, as already done by Stewart, but the pertinent objections were not discussed in Eames' paper; Eames says that Schmidt's designation seems to be "the earliest valid" one, referring only to

<sup>5</sup> CHAVAN, A., *Essai critique de classification Lucines. I.* Journ. Conchyl. 81: 133-153. 1937.

Winckworth's general opinion on such selections by Schmidt.

The third is by Children (1823), and I had accepted it in my first paper (*op. cit.*). But Children referred only to Lamarck's *Lucina*, and his designation of *L. jamaicensis*, like that of *pennsylvanica* by Schumacher, deals only with *Lucina* Lamarck. Recent additions to the Rules do not permit the consideration of *Lucina* Bruguière as a *nomen nudum*, apart from its interpretation by Lamarck (which was possible when I wrote my first paper).

Anton's designation of *L. pennsylvanica* (1839) has been accepted by Stewart as the first valid one. It is the only one *Lucina* printed by Anton in small capitals. But, although indicating in his introduction that such a printing was reserved to generic typifications, Anton commonly used it also for subgenera. In the case of *Lucina*, four "groups" are recognized, instead of subgenera, the first species of each being printed in italics. This printing typifies them, as pointed out by Eames (*op. cit.*). *L. pennsylvanica* being also printed in italics ahead of the third group (c), is thus on the same rank that three other species, despite the fact it was also printed in small capitals when listed among the heterogeneous species of group c. One can hardly know what printing must prevail, since the "type designation" is here subordinated to a "group" subdivision and typification.

Herrmannsen's designation (1847) of *L. pennsylvanica* is for *Lucina* Bruguière and *Lucina* Schumacher. But the same year, Gray has given the first valid designation I have been able to find, of *L. jamaicensis* as the type of *Lucina* Bruguière, while *Lucina* Schumacher is clearly separated as a synonym, having another type (*pennsylvanica*). This selection is not only the first unquestionable one, but it is in accordance with Lamarck's first implicit selection (1801), quoted above and confirmed by Children's designation for *Lucina* Lamarck, 1801, which therefore is a synonym of Bruguière's genus.

Gray's selection has been followed by subsequent best authors, like Stoliczka (1871) and Meek (1876) and has been disregarded only when opinions favoring the retention of "*Venus edentula*" by "monotypy" have been expressed. This "monotypy" referring to Lamarck's work of 1799, now rejected for type-designations, and both Schmidt's and Anton's choices proving to be questionable, *Lucina jamaicensis* must be

accepted as the type of *Lucina* Bruguière, as designated by Gray, 1847.

It is interesting to point out that the former Rules—now rejected but followed during many years by well-known specialists—would have led to the same conclusion, if the type had to be chosen "by elimination"; *L. edentula* being then rejected for inappropriateness, and *L. pennsylvanica* as excluded from the "Lucines" by Roissy, *L. jamaicensis*, first and single species cited in 1801, would have been yet the only one to be validly available.

As in any manner, and in total accordance with the present Rules, *L. jamaicensis* is the type of *Lucina* Bruguière—unless we accept arbitrarily another designation among the prior ones, which prove all to be strongly questionable, it is here proposed that *Lucina*, with *jamaicensis* as its type, shall be soon placed in the "Official List of Generic Names", this having the advantage of definitely saving the well-known *Linga*, which is available for the *pennsylvanica* group, and of rejecting in synonymy the vernacular *Phacoïdes*, generally used for designation of any lucinid that can not receive an exact generic assignment.

#### PHACOÏDES

As often pointed out, *Phacoïdes* "Blainville, 1825" (Diet. Sci. Nat. 32: 334) is only a vernacular name<sup>6</sup>: "Les Lucines Phacoïdes" having no status. *L. jamaicensis* is cited under it as an example.

The word *Phacoïdes* is found first in Agassiz (Nom. Zool. Moll. 2: 67) in 1845 as a name without species, being merely a quotation from Blainville. Its second use is by Gray, 1847 (Proc. Zool. Soc. London: 195) in the synonymy of *Lucina*, of which *L. jamaicensis* is designated as the type. Its third use is by H. and A. Adams, 1858 (Gen. Rec. Moll. 1: 467), also as a synonym of *Lucina* Bruguière, of which *L. jamaicensis* is given as an example.

Eames (*op. cit.*), having selected *L. pennsylvanica* as the type of *Lucina*, thinks that *Phacoïdes* (Blainville) H. and A. Adams can be accepted as "the first valid use of this name" with *L. jamaicensis* as monotype. But it is not the first valid use at all: despite the fact that Agassiz first used *Phacoïdes* as a genus without species, Gray, prior to H. and A. Adams, used it also as a synonym of *Lucina*, and with a type-designa-

<sup>6</sup> See Iredale (1915), Stewart (1930), Eames (1951).



tion for the latter not only an example. I cannot understand how the citation of *jamaicensis* as example only for *Lucina* can be applied as a monotype for *Phacoides*: such a selection after Adams cannot be accepted.

But as Gray himself has only quoted *Phacoides* in synonymy of a nonmonotypical genus, his type-designation for *Lucina* is not, *ipso facto*, available for *Phacoides* as monotype. *Phacoides* itself cannot be monotypical, Blainville having written "Les Lucines Phacoides."

Agassiz, Gray, and Adams have all only quoted the word "Phacoides" after Blainville in their papers, without species referred to this name; it is not even certain that they have used it as = Latinized. One cannot affirm that they intended to quote a Latin genus *Phacoides*, instead of only a French word, transferred from an adjective to a substantive: (Les) Phacoides. So that "Phacoides" must be rejected as vernacular in any manner, no Latin use of it prior to *Dentilucina* Fischer, 1887, being demonstrated by its connection to a specific Latin name. Neither Gray nor Adams have referred to "*Phacoides jamaicensis*" but only listed a vernacular name in a synonymy; and on page 194 of his paper, Gray similarly quoted as a synonym of a Latin generic name (*Agaria*) the "Cardito-Cardite" of Blainville under its vernacular form, not *Cardiocardita*.

If a valid and unquestionable designation of *L. pennsylvanica*, or of any species other than *L. jamaicensis* is found as the type of *Lucina* Bruguière prior to Gray's selection, *Dentilucina* would then replace *Lucina* for the *jamaicensis* group, and not *Phacoides*, as several authors have already noted.

Before studying other names, it is interesting to point out that a case almost similar to that of *Cardita* and *Lucina* has been ruled recently by the International Commission in the same sense. *Arca Noae* Linné has been officially established as the type of *Arca* Linné, 1758, following Gray's selection, instead of Schmidt's or Schumacher's prior, but questionable, designations. But in the case of *Arca*, a suspension of the Rules was necessary, because Schumacher's designation was only somewhat questionable, according to Reinhart (1935) but not to most authors. In the case of *Cardita* and of *Lucina* such a suspension would not be needed, all designations prior to Gray's being evidently erroneous in their references, and not concerning Bruguière's work.

#### DIPLODONTA AND TARAS

*Diplodonta* Bronn, 1831 (Ergebn. Nat. Reisen 2: 484), is a well-known unguulinid, with *Venus lupinus* Brocchi (non Linné) = *Tellina rotundata* Montagu var. *aequilateralis* Cerulli (*Diplodonta*) as its type, designated by Herrmannsen and by Gray, both in 1847. There is a prior *Mysia* Leach in Brown, 1827, with the same species as monotype, but invalidated by *Mysia* Lamarck, 1818.

There is also *Taras* Risso, 1826, type (monotype) *T. antiquatus* Risso (Hist. Nat. Eur. Mérid. 4: 344) from the Pliocene beds of La Trinité, near Nice. Stewart (*op. cit.*) thinks that this species is identical with the Recent *Diplodonta rotundata* (Mtg.) and therefore that *Taras* must have priority over *Diplodonta*.

*Taras antiquatus*, only figured by Risso, looks, in fact, like *Diplodonta rotundata*. Dall had interpreted the diagnosis of its hinge as that of a specimen of this species on which the left posterior cardinal was broken off, and the right posterior confused with a lateral tooth. But Cerulli (1909) and Lamy (1920) treated *Taras* as a doubtful name, and Eames (1951) also has recently listed it as a *nomen dubium*.

Stewart was of the opinion that "it should not be difficult to identify *T. antiquatus* at Trinité." However, in this locality as well as on the Mediterranean coast, another quite different species can be found which is externally and internally very similar to *Diplodonta rotundata*. Modern authors seem not to have realized that *Taras antiquatus* was, perhaps, a specimen of *Mysia undata* (Pennant), also known as *Lucinopsis undata*.

It is a venerid, with a deep pallial sinus, and a third narrow, cardinal tooth, just in front of the nymph (perhaps the "right posterior" discussed by Dall): however, both the shape and hinge of *Mysia undata* recall strongly *Diplodonta rotundata*, especially when the specimens are worn. Both species are not uncommon in the recent fauna.

As I have failed to find specimens labelled *Taras antiquatus* in the Risso material preserved in the Paris Museum, I am of the opinion that the name must be rejected as a *nomen dubium*, since it may be that Risso has described a *Mysia*, as well as a *Diplodonta*, and since no type material can be studied.

I have noticed, when examining Risso's shells, that their original labels have, sometimes, been

misplaced and several specimens apparently misidentified. If some day shells labelled "*Taras antiquatus*" should be discovered (and probably not, then, in the Paris Museum where I have failed to find them and where they have not been listed), it would be yet necessary to verify with much care if they are really the true *Taras* Risso has studied. So that there is only a very slight possibility that *Taras* can have status of any kind, and *Diplodonta*, therefore, can be confidently used.

I have failed to find, among numerous

**BOTANY.**—*New species of grasses from Venezuela.* AGNES CHASE, Department of Botany, U. S. National Museum.

The genus *Thrasya* H.B.K., Nov. Gen. et Sp. 1: 120. pl. 39. 1816, was based on a single species, *T. paspaloides* H.B.K., collected by Humboldt and Bonpland on the island of Panamuna, in the Orinoco between Atures and San Borja, Venezuela. There are now 12 known species of *Thrasya*, ranging from Costa Rica to Brazil and Bolivia, four of them from Venezuela, to which a fifth is now proposed. In this genus the sterile lemma is mostly firm, thinner and sulcate down the middle and usually splitting to the base, the margins of the split rolling inward. In the species here described the sterile lemma partly splits tardily or not at all, as in *T. campylostachya* (Hack.) Chase and *T. hitchcockii* Chase, and the plant somewhat resembles *Paspalum pilosum* Lam.

***Thrasya venezuelana* Chase**

**Fig. 1**

Planta perennis; culmi 50 cm alti, erecti, dense hispidi, nodis inferioribus ramosi; vaginae et laminae appresso-hispidae; ligula minuta; laminae 15-20 cm longae, 6-8 mm latae; racemi 1-3, arcuati, 8-13 cm longi, rhachi 2 mm lata, marginibus longe hispidis; spiculae crebrae, 4 mm longae, 2 mm latae, dense hispidae; gluma prima obsoleta; gluma secunda et lemma sterile subaequalia, 3-nervia, lemmate sterili sulcato non vel tarde fisso; fructus 3.5 mm longus, 1.5 mm latus, marginibus lemmatos et paleae appressopubescentibus.

Perennial, in small tufts; culms 50 cm tall, erect, appressed-hispid, branching from the lower nodes, the lower internodes 4-5 cm long, the

carditid and lucinid units, other unsettled generic terms of the importance of those here discussed; so that I think it was of interest to study them in full, as I have tried to do it in the present paper. It is very satisfactory to see that a strict application of the International Rules has succeeded in saving well-known names. Wise decisions of the Commission having already placed several usual genera in the Official List, I hope that *Cardita*, *Lucina*, and *Diplodonta*, at least, may obtain the same favor.

nodes densely hispid; branches erect, the prophylla prominent, thin, to 5-6 cm long; foliage conspicuously appressed-hispid; sheaths exceeding the internodes; ligule a brown membrane 0.5 mm long; blades rather thick, 15-20 cm long, 6-8 mm wide, about as wide at the base as the summit of the sheath, folded and flexuous in age; racemes on slender erect peduncles, 1-3 from the upper sheaths, the racemes strongly arcuate, 8-13 cm long, the rachis narrowly winged, 2 mm wide, appressed-pubescent, the margins long-hispid; spikelets crowded, 4 mm long, 2 mm wide, rather turgid; first glume obsolete; second glume and sterile lemma 3-nerved, densely hispid with pale hairs, the glume slightly shorter than the lemma, the lemma sulcate, not or tardily partly splitting, its palea of equal length, with firm minutely pubescent margins, enclosing 3 rudimentary stamens; fruit 3.5 mm long, 1.5 mm wide, subacute; lemma and palea minutely papillose-striate, the margins of both sparsely appressed-pubescent.

Type in the U. S. National Herbarium, no. 1762139, collected on dry stony open slope, among low brush, Sabanas de Cotiza, Distrito Federal, Venezuela, March 11, 1940, by Agnes Chase, no. 12407. Part of the type is in the herbarium of the Instituto de Botánica, Caracas, Venezuela.

***Ichnanthus tamayonis* Chase**

**Fig. 2**

Planta annua; culmi ramosi decumbentes, 65-90 cm longi, gracillimi, angulati, pilosi, internodiis inferioribus brevis, nodis tumidis, saepe radicosis, superioribus ad 15 cm longis; vaginae

pilosae, marginibus ciliatis; ligula 0.3 mm longa; laminae anguste lanceolatae, 5-10 cm longae, 4-7 mm latae, acuminatae, basi rotundatae, tenues, laxae, subtus molliter pubescentes, supra scaberulae; paniculae terminales et axillares, 6-8 cm longae, 3-4 cm latae, laxae, ramis ascendentibus, 1-5 cm longis, ramulis 1-3 spiculas ferentibus; spiculae 4.2-4.4 mm longae, glumis et lemmate sterili acuminatis; fructus 2.6 mm longus, basi appendicibus nullis.

Annual; culms decumbent, 65-90 cm long, very slender, angled, pilose, the lower internodes short, the nodes swollen, few to several of them with slender prop-roots 4-10 cm long; sheaths, except the uppermost, 1-2 cm long, the uppermost 3-4 cm long, pilose (the uppermost sparsely), the margins densely ciliate; ligule membranaceous, 0.3 mm long; blades narrowly lanceolate, 5-10 cm long, 4-7 mm wide, long-acuminate, rounded at base, thin, lax, softly pubescent on the lower

surface, the upper surface subglabrous, the fine nerves scaberulous; panicles terminal and axillary on long very slender angled peduncles, pilose below the panicles; terminal panicles lax, 6-8 cm long, 3-4 cm wide (the axillary mostly smaller), the very slender angled axis sparsely pilose, the branches ascending, 1-5 cm long, with short ascending branchlets bearing 1-3 short-pedicellate spikelets, at least the lower axils pilose; spikelets 4.2-4.4 mm long; first glume long-acuminate, a little shorter than the sterile lemma, 3-nerved, the midnerve scabrous; second glume acuminate, 4.2-4.4 mm long, 5-nerved, the nerves scabrous, sometimes with a few hairs on the midnerve; sterile lemma 4-4.1 mm long, 5-nerved, the nerves scabrous; fruit 2.7 mm long, the basal wings reduced to scars.

Type in the U. S. National Herbarium, no. 1858484, collected in "sitios abrigados, Dist. Fed.:

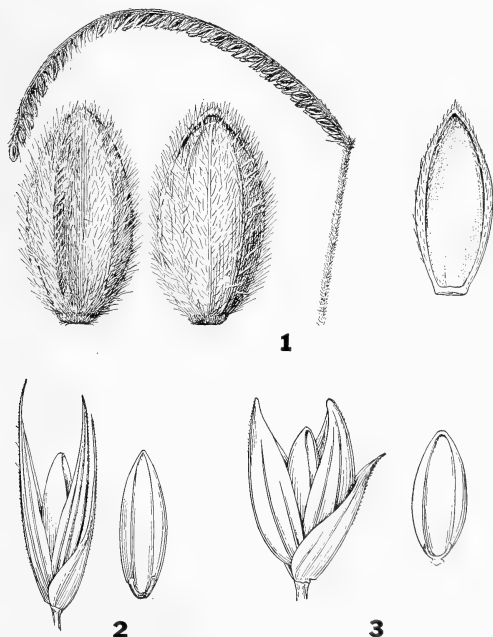

FIGS. 1-3.—*Thrasya venezuelana*, n. sp.: 1, Raceme,  $\times 1$ , two views of spikelet, and fruit,  $\times 10$ , type; 2, *Ichnanthus tamayonis*, n. sp.: Spikelet and fruit,  $\times 10$ , type; 3, *Ichnanthus nubilus*, n. sp.: spikelet and fruit,  $\times 10$ , type.

Carretera Catia - El Junquito," Venezuela, October 8, 1943, by Francisco Tamayo, no. 2564.

A duplicate of the type is in the herbarium of the Instituto de Botánica, Caracas, Venezuela.

***Ichnanthus nubilis* Chase**

Fig. 3

Planta annua; culmi ramosi decumbentes, 60-100 cm longi, graciles, angulati, infra nodos papilloso-pilosi; nodi pilosi; vaginae papillosoe-pilosae; internodii 1.2-2.5 cm longi, papilloso-pilosi, ciliati; ligula brevissima; laminae anguste lanceolatae, 5-10 cm. longae, 4-8 mm latae, acuminatae, basi constrictae, tenues, infra obscure reticulatae; paniculae terminales et axillares, pedunculis gracillimis longissimis; paniculis 2.5-3.5 cm longis, 5-10 mm latis, 2-6 spiculis ferentibus; spiculae 3.5 mm longae, glumis et lemmate sterili firmis; gluma prima acuminata 2/3-3/4 spiculae aequans, 5-nervis; gluma secunda 3.5 mm longa, subacuta, 5-nervis; lemma sterile 5-nerve, quam gluma secunda brevis; fructus 2.5 mm longus, basi appendicibus nullis.

Plants annual; culms decumbent, 60 to 100 cm long, slender, strongly nerved to angled, papillose-pilose below the nodes and sometimes along one of the nerves; nodes pilose; sheaths much shorter than the internodes (mostly less than 2.5 cm long), finely papillose-pilose, at least

toward the summit and on the collar, finely ciliate; ligule minute; blades narrowly lanceolate, 5-10 cm long, 4-8 mm wide, acuminate, narrowed at base, thin, faintly reticulate on the lower surface, and sparsely pilose to glabrous on both surfaces; panicles terminal and axillary on long very slender angled peduncles, the panicles 2.5-3.5 cm long, 5-10 mm wide, the short ascending scabrous branches bearing 2-6 short-pedicelled spikelets; spikelets 3.5 mm long, the glumes and sterile lemma firm; first glume abruptly acuminate, 2/3-3/4 as long as the spikelet, 5-nerved, the midnerve scaberulous toward the apex; second glume 3.5 mm long, subacute, 5-nerved; sterile lemma similar to the second glume, slightly shorter, 5-nerved; fruit 2.5 mm long, the basal wings reduced to scars.

Type in the U. S. National Herbarium, no. 1762167, collected near the upper margin of cloud forest, El Junquito, Cordillera Costanera, Distrito Federal, Venezuela, March 12, 1940, by Agnes Chase, no. 12439.

A duplicate of the type is in the herbarium of the Instituto de Botánica, Caracas, Venezuela.

*Ichnanthus tamayonis* and *I. nubilis*, creeping, shade-loving species, resemble *I. angustifolius* Swallen of the Eastern Cordillera of Colombia, but are freely branching and bear axillary as well as terminal panicles with spikelets glabrous or with scabrous nerves only.

**ENTOMOLOGY.**—Notes on *Bruchidae* affecting the *Anacardiaceae*, including the description of a new genus. JOHN COLBURN BRIDWELL, Lignum, Va. (Communicated by Waldo L. Schmitt.)

Anyone interested in the *Bruchidae* is intrigued by the relatively few species that diverge from the usual family habit of feeding their young in seeds of legumes by attaching themselves to plants of other families. We have three records of *Bruchidae* affecting the *Anacardiaceae*, a family of plants represented in temperate North America almost entirely by the polymorphic genus *Rhus*, including the sumacs, poison ivy, and smokebush. The genera affected by *Bruchidae* are Chilean and Brazilian, and both are close allies of *Rhus*. These genera are *Duvaia* Kunth, now usually included in *Schinus* Linnaeus, which includes the "California" peppertree, and *Lithraea* Miers, which includes the Chilean litre, *L. caustica* (Molina) Hooker & Arnott (*venenosa* Miers).

1. GALL-MAKING BRUCHID OF *Schinus huigan* (CHILE)

Kieffer and Herbst (Zeitschr. Wiss. Insekt.-Biol. 1: 66. 1905) reported a bud gall in the axils of the flowering twigs of *Duvaia dependens* DC (= *Schinus huigan* Molina), which is described as follows: These are easily dislodged, being attached at only a single point. The gall is ellipsoidal, 6-8 mm high by 5-6 mm broad, naked, red flecked with white, the middle of the flecks sometimes tuberculately prominent. The texture of the gall is somewhat woody. Within the gall lies a thick curved footless beetle larva with the body gradually thickened behind, 8-9 mm long by 2-3 mm broad, naked except for some scattered hairs on the anterior segments, mandibles dark.

This material was obtained by Pablo Herbst between Santiago and Valparaiso on November

3, and later a new species of *Bruchus* was reared from these larvae.

Since this still undescribed species is one of the few Bruchidae affecting plants in parts other than seeds, it would be a useful work for some of our Chilean friends to recover this species and have it described.

## 2. *Lithraeus electus* FROM THE SEEDS OF LITRE (CHILE)

Prof. Carlos Porter (Revista Chilena Hist. Nat. 29: 286. 1925) reported determining the attractive *Bruchus elegans* Blanchard in material submitted to him for identification by Prof. Flaminio Ruiz, obtained by the latter from the seeds of litre, *Lithraea caustica*, from Sauzal (Province of O'Higgins) in January 1924. Since Camacho (*Algunos insectos perjudiciales á las arvejas, frijoles, lentejas y otras legumbres y brucos del trebol*, Serv. Policia Sanit. Vej., Santiago de Chile, 1919: 22-23) had previously erroneously reported this species affecting seeds of clover, I sought confirmation for Professor Porter's record. With this in mind I examined several lots of seeds of litre in the collection of the Office of Foreign Plant Introduction, U. S. Department of Agriculture. In one of these lots (S.P.I. No. 27434) were found four seeds showing insect injury. Three exhibited exit holes, evidently of some hymenopterous insect smaller than *Bruchus elegans*. This should be a parasite of a bruchid, but it might also be some seed inhabiting chalcid. Fortunately, the fourth seed still contained an insect. When this was extracted from within its slight silken cocoon, there was found a nearly mature braconid identified by C. F. W. Muesebeck as a species of *Urosigalphus*. Since some of the species of *Urosigalphus* parasitize bruchids, and others attack curculionids, the remains of the beetle larva at the expense of which the *Urosigalphus* larva had nourished itself were extracted and submitted to Dr. Adam Böving. The fragments were sufficient to enable him to determine them positively as those of a bruchid larva. We may hope that ultimately the larvae of Bruchidae will be identifiable, since Dr. Böving has admirably worked out the mouth parts (Proc. Ent. Soc. Washington 29: 133-143. 1927). However, the larva of *Bruchus elegans* is still undescribed, and so no matter how perfect the larva might be it would still be impossible to determine it to species. We were not, therefore, quite able to confirm fully Professor Porter's record as to the species concerned. But a bruchid

certainly does affect the seeds of *Lithraea caustica* in Chile, and I have no doubt that he is right in his determination, for *Bruchus elegans* is a common, well-known, and strongly characterized species not likely to be mistaken.<sup>1</sup>

Unfortunately, the appropriate specific name *elegans* Blanchard, 1851, is preoccupied by *Bruchus elegans* Sturm, 1845, a valid binomial, and must be replaced. Furthermore, the varietal name *obscurior* Pic, 1902, is also preoccupied<sup>2</sup> and cannot take its place. The species is, I believe, distinct enough to represent a separate genus, and *Lithraeus* is proposed with *Bruchus elegans* Blanchard, 1851, as genotype. For the untenable specific name *elegans* the substitute *electus* is proposed, so that this beautiful seed weevil of the litre may be known hereafter as *Lithraeus electus*.

**Lithraeus**, n. gen. (Bruchinae, Acanthoscelidini)

Genotype: *Lithraeus electus*, n. name

*Bruchus elegans* Blanchard, 1851, not Sturm 1843.  
*Bruchus elegans obscurior* Pic, 1902, not *Bruchus (Pseudoptinus) martini obscurior* Pic, 1896.

Freshly emerged individuals of this elegant Chilean bruchid may best be recognized by the pubescent markings, which later are often badly rubbed. With fine sericeous pubescence on head, body and legs above and below, invisible except when seen obliquely; sharply defined decorations of dense snowy white pubescence concealing the surface thus: a small quadrangle on median lobe of pronotum; on the small quadrate scutellum (emarginately bidentate at apex), narrow arcuate elytral fasciae extending obliquely forward from near the middle of fourth stria to near basal third of ninth, an elliptical fleck at the apex of the fourth and fifth striae, on mesepimeron, on narrow outer margin of metapleura, on outer end of hind coxa and small maculae on extreme margin of sternites 2-4, narrow basal margin of pygidium; less condensed and less definite pubescent markings on posterolateral lobes or angles of pronotum and on its flank near front coxa.

Small, 2.3-3.1 mm long by 1.3-1.6 mm broad, ovate, shining black or reddish testaceous, with almost all parts rufescent in some individuals;

<sup>1</sup> Since this part of this paper was prepared, repeated positive proof of this host relationship has been obtained. I do not have any confirmation of Dr. Porter's subsequent record (Revista Chilena Hist. Nat. 43: 139-140. 1940) of its affecting *Schinus molle* L., the so-called "California" peppertree.

<sup>2</sup> *Bruchus (Pseudoptinus) martini obscurior* Pic, 1896, now referred to *Ptinus*.

head, prothorax, and body beneath generally black; antennae sometimes entirely black, sometimes with some basal joints reddish. Integument everywhere micropunctulate, with coarser punctures on head, pronotum, and hind coxa. Head short, malar space short, temples abruptly declivous; eyes normally convex and projecting, broadly emarginate for two-thirds their length, separated on front by nearly the width of an eye.

Front punctured throughout, without a carina, glabrous impunctate line, or area; antennae alike in the sexes, extending beyond base of pronotum but not to hind coxa, with four narrow joints at base, joint 5 triangularly expanded at apex, 6-10 nearly alike, subquadrate, closely applied to each other, not at all serrate, 11 broadly ovate. Pronotum narrower than elytra and less than half as long; sides nearly straight, converging and suddenly rounded in front; dorsum nearly even, convex, separated from flanks by a vestigial lateral carina bent down to the coxa. Elytra with even surface, flat intervals, epipleural lobes well developed, humeri small, no basal tubercles, striae except 8 and 9 reaching base, 4 and 5 abbreviate and joined at apex, striae perceptibly punctured, well impressed; elytra broadest near basal third, narrowed to apex, covering base of pygidium, not microserrate at suture. Hind coxa broader than hind femur and broader than first sternite behind it, finely punctured except for the polished area along more than half the anterior margin; hind femur more than three times as long as broad, not extending to apex of abdomen, arcuate above, nearly straight beneath, sinuate before the small apical lamella; slightly flattened apically, inner margin with vestigial carina usually bearing a slightly angulate denticle; hind tibia straight, slightly broader toward apex, entirely without longitudinal carinae, apex abruptly truncate, mucro short and but little different from the lateral tooth which is near it, separated by a shallow sinus; subdorsal denticles smaller, two or three in number.

Numerous American Bruchidae such as *Bruchus* (*Pachymerus*) *albotectus* Sharp, *Bruchus* (*Pachymerus*) *incrustatus* Gyllenhal, and *Pseudopachymerus multimaculatus* and *binotatus* Pic, which have been referred to *Pseudopachymerus* or *Caryedes*, from which they are generically distinct, have the elytra with dense white pubescence over most of the surface but in *Lithraeus electus* most of the elytron is covered with practically invisible pubescence and the white covers

only a minor part of the surface. These species with longitudinally carinate hind tibiae and femur armed with tooth and denticles near apex beneath are widely separated from *Lithraeus* by the structure of the hind legs. Most genera of Acanthoscelidini have longitudinal carinae on the hind tibiae: (1) One on outer face ending in a tooth at apex. (2) One on ventral margin ending in the mucro at apex; (3) One on the surface between outer and ventral carinae, often converging apically toward the ventral carina; (4) One on the inner face, not related to any apical structure. The complete absence of such carinae in *Lithraeus* distinguishes it from any other American bruchid genus known to me.

### 3. A BRUCHID FROM THE SEEDS OF AROEIRA (BRAZIL)

Gregorio Bondar, 1937, records a third bruchid affecting a plant of the family Anacardiaceae in Brazil (Rio) in his *Notas biológicas sobre bruchídeos observados no Brasil* (Arch. Inst. Biol. Vegetal **3**: 7-44, figs. 1-61 [December, 1936]), a work largely reprinted from previously published papers in *Correio Agrícola* (Bahia), *O Campo* (Rio de Janeiro), *Revista de Entomologia* (Rio de Janeiro), and perhaps elsewhere, 1930-1932, the details of which I cannot here quote. This paper by Bondar is the most significant single contribution to the biology of Bruchidae known to me. Bondar's too brief note (p. 43) reads thus: "*Bruchus atronotatus* Pic. Cria-se em sementes de aroeira. Rio."

The bruchid species was described by Pic 1929, *Mélanges* **54**: 35, Brésil (type in coll. Pic). It was listed by Blackwelder, *Checklist of the coleopterous insects of Mexico, Central America, the West Indies, and South America*, U. S. Nat. Mus. Bull. 185 (pt. 4): 758. 1946, as *Acanthoscelides atronotatus* Pic. I do not have the description before me, but I doubt if it would be of service in determining the species if it is in any way like *Lithraeus electus* or particularly related to it.

From Dr. Da Costa Lima's very useful "Índice das Plantas" in his *Terceiro catalogo dos insectos que vivem nas plantas do Brasil*, Rio de Janeiro, 1936, p. 426, we find the vernacular name *aroeira* with or without an adjective, *brava*, *mansa*, or *preta*, applies to *Lithraea brasiliensis*. *Aroeira vermelha* or *manza* is *Schinus terebinthifolius*. My impression is that Bondar meant *Lithraea brasiliensis* as the host of *Bruchus atronotatus*.

ENTOMOLOGY.—*Descriptions and notes on two rare species of Aphididae.* F. C. HOTTES. (Communicated by Herbert Friedmann.)

Opportunity is taken to describe some forms heretofore unknown of two rare species of Aphididae, and to record some notes on their life habits.

*Rhopalosiphum grabhami* Cockerell

This species was described by T. D. A. Cockerell in 1903. Since that time I am aware of its mention in aphid literature only once, by Gillette and Palmer in 1932. In the fall of 1951 it was present in numbers in pseudogalls made by rolling both halves of the leaf blade toward the midrib. On *Lonicera involucrata* the galls thus formed were red, mottled with yellow. The edges of the leaves were tightly rolled into tubes just large enough for the bodies of the aphids. In such tubes numerous aphids apparently adult, but with undeveloped wings were taken dead, killed by a fungus. Toward the midrib the leaves were more loosely rolled, and it was in these regions that living alate viviparous females and males were taken. Oviparous females were not taken. The male has not been described before.

ALATE MALE

*Size and general color.*—In life very much shriveled and shrunken; general color black. Mounted specimens, relaxed and cleared, are about 1.45 mm long from vertex to tip of anal plate; width across eyes, 57 mm. Mounted specimens show the head and thorax blackish brown, abdomen with dusky spots at the sides, and smaller spots, irregular in shape and size, arranged in transverse rows across the dorsum. The median spots are larger and more or less confluent, near the posterior; cauda and anal plate dusky; cornicles dark dusky; antennae uniform black; tibiae dark brown with apical portions darker.

*Head and appendages.*—Comparative lengths of antennal segments as follows: III, .57 mm; IV, .37 mm; V, .31 mm; VI, .11 + .52 mm. Antennal hair slightly knobbed, that on III not so long as width of segment. Secondary sensoria round, tuberculate, arranged as follows: III, 56-60 evenly distributed over surface; IV, 33 evenly distributed; V, 5-11 more or less in a row. All antennal segments imbricated. Primary sensoria on V and VI with a hair rim. Anterior margin of head with a strongly developed me-

dian tubercle. Antennal tubercles extremely well developed. Rostrum very short, extending only about midway to mesothoracic coxae, segment before apex very bulbous.

*Thorax.*—Veins of forewings dark dusky brown; second branch of media about midway between first and margin of wing; radial sector much bowed; hind tibiae 1.07 mm long; hair on inner surface of hind tibiae more abundant than that on outer surface; hair on both surfaces equal in texture and about equal in length. The hair on the proximal surface of the tibiae is shortest, length of hair in midregion less than width of tibiae; apex of tibiae somewhat enlarged. Tarsi .08 mm long. First segment of tarsus deeply recessed within tibiae, this is also true of alate viviparous females. First segment of tarsus apparently with only two hairs.

*Abdomen.*—Cornicles .20 mm long, with surface imbricated, sides almost uniformly swollen, slightly constricted just before well-developed rim. Cauda, .057 mm long, with three hairs on a side. Anal plate with few long hairs. Gonapophyses short with numerous hair.

*Allotype alate male.*—Collected September 7, 1951, Skyway, Colo. (Cottonwood Lake Trail) deposited in United States National Museum.

I am not sure that this species is correctly placed in the genus *Rhopalosiphum*. It has much in common with the *Myzini*.

*Lachnus montanus* (Wilson)

This species was described by Wilson in 1919 from three "apterous viviparous" females collected by Gillette at Cimmaron, Colo. in 1906. I am not aware of other specimens having been recorded in aphid literature since that time. Dr. Knowlton, however, has sent me an unidentified slide of this species to determine, collected by B. A. Hows at Vallecitos New Mexico in 1943. The host is not recorded; the specimens are apterous.

This species is of especial interest because two kinds of apterous viviparous females occur; females with no sensoria on the hind tibiae and females with sensoria on the hind tibiae. It was from females of the latter type that Wilson described the species. At the time he stated that it was possible for the females to be oviparous, a possibility he promptly rejected because the

specimens were collected in August which he thought too early to produce oviparous females. Despite the presence of sensoria on the hind tibiae, a characteristic as a rule of oviparous females, but not confined to them, such females are viviparous. I can not state that they are always thus, but my material so indicates. They seem to occur in the fall as a generation just preceding the oviparous generation. Because they differ in other respects in addition to the presence of sensoria on the hind tibiae they must be regarded as distinct forms. I have been informed by Professor Palmer, that Professor Essig has a paper in press in which he calls similar forms produced in another genus "intermediates" and I make use of his term. It was my intention to call them pseudo-oviparous.

I took all my specimens in a small region south of Glade Park, Colo. (Piñon Mesa), on scrub oak (*Quercus gunnisonii*). On the larger trees of this species they apparently live singly, or in the case of immature specimens in groups of two or three. I have taken them on the twigs, branches, and trunk. On twigs they seem to show a preference for regions near twig galls, and in one case I collected a female with the head and a portion of the thorax in the cavity of a gall, too small to admit the entire body. On branches and on the trunk, rough regions seem preferable. Even when directed to them by ants, collecting of this species is slow and tedious. By actual count only five mature specimens were taken in three afternoons collecting, on mature trees. Quite by accident I chanced to stop to examine some small seedlings not more than 3 feet high and found that they had fairly large colonies of oviparous females and males on the trunks, not more than a foot from the ground. If this represents the normal preference for this species, perhaps it explains why this species is so rare in aphid collections.

#### APTEROUS MALE

*Size and general color.*—In life black, very insignificant looking, being much shrunken and very shriveled. Mounted specimens, after clearing and relaxing, vary in length from 2.07 to 2.50 mm. Mounted specimens have the head and thorax dusky brown, abdomen greenish with large lateral dusky areas; dorsum of abdomen with many dusky spots, which vary greatly in size and shape. Posterior region of abdomen dusky; cornicles dusky; antennae with the ex-

ception of the base of third dark dusky brown; femora brown at base shading to almost black; tibiae and tarsi uniform dark brownish black.

*Head and appendages.*—Width of head across eyes .715–.78 mm. Anterior margin of head rather flat with numerous long hair; median suture present; first and second antennal segments with numerous short, rather thick hair. All antennal segments imbricated; hair on antennal segment III, IV, and V spinelike and for the most part about as long as width of segment. Secondary sensoria distributed as follows: III, 10–39; IV, 0–2; V, 1–6. The specimen that had the fewest sensoria on III had the most on V. Marginal sensoria on VI far removed from primary, rather large, sometimes difficult to determine, most commonly three. Proportional lengths of antennal segments as follows: III, .715–.815 mm; IV, .314–.371 mm; V, .30–.343 mm; VI, .143 + .085–.185 + .128 mm. The unguis is outstandingly long and thick. Ocular tubercles present, well developed. The rostrum reaches almost to the cornicles.

*Thorax and abdomen.*—The hind tibiae measure 2.28–2.41 mm in length. The hind tarsi are .347 mm long. The hair on the hind tibiae is about equally well developed on all surfaces, in length it is subequal to the width of segment. The ventral surface of the first segment of the hind tarsus has about 15 hairs, the dorsal surface 3. The cornicles measure .171–.214 mm at the base, which is rather irregular in outline. The cauda and anal plate are rounded. The hair on these structures and on the cornicles is longer than that found on other parts of the body. The gonapophyses have what appear to be tufts of hair at their ends.

#### APTEROUS VIVIPAROUS FEMALE

*Size and general color.*—Length varying from 3.50 to 3.78 mm. Immature specimens of this species are so large that they may be taken for adults in the field. Body highly arched and much inflated except in regions of spots which appear deeply pitted. Color of head and thorax light brown with a very scant amount of pulverulent matter. Abdomen the color of cocoa with a rather thick hoar-frost pulverulence covering all but the cornicles, which are dark brown, very small lateral tubercles and areas which surround them, which are also brown, and small rather deeply pitted areas arranged in four rows on the dorsolateral surface of the abdomen.



These areas, which appear to be glandular, are most likely not wax glands, being free from pulverulent matter. First and second antennal segments slightly darker than the head, third segment yellowish brown at base shading to dark dusky brown, remaining antennal segments dusky; femora brownish at base shading to very dark dusky brown if not black; tibiae almost uniform brownish black, tarsi the same. Mounted specimens may show dusky areas on dorsum of abdomen. When present, these are irregular in outline and variable in size.

*Head and appendages.*—Width of head across eyes .57 mm; antennal segments with the following proportional lengths: III, .71–.78 mm; IV, .30–.314 mm; V, .314–.347 mm; VI, .157–.171 + .114 mm. The unguis is very long and thick. The secondary sensoria are distributed as follows: III, none; IV, 0–2; V, 0; marginal sensoria on VI far removed from primary; first and second antennal segments with more hair than usual; antennal hair spinelike, not so long as width of segment; antennal segments imbricated; primary sensoria free from hair ring; rostrum nearly reaching to base of cornicles; ocular tubercles poorly developed; head with a median suture, which continues more or less on the segments of the thorax, never being complete on any one segment.

*Thorax.*—The metathoracic femora are much longer than those of the prothorax and mesothorax, measuring 1.64 mm in length; the hind tibiae are 2.86 mm long; the hind tarsi measure .34 mm in length. The hair on the tibiae are spinelike and arise from clear areas which stand out from the otherwise very dark color of the tibiae; hair on tibiae not as long as width of tibiae, not all of uniform length, longest hair dull at the tip; first segment of hind tarsi with nine hairs on ventral surface and three on dorsal.

*Abdomen.*—Cornicles with base varying from .257 to .286 mm; base very irregular in outline with about four rows of hair; abdomen with much hair; cauda narrow but deep, with two kinds of hair: long spinelike hair on the margin and short fine hair on the dorsum. Anal plate rounded.

#### INTERMEDIATE VIVIPAROUS FEMALE

It was this form that Wilson described. Specimens of this form resemble the viviparous females just described in color. They differ from such females in size, varying from 3.78 to 4.00

mm, in length of sixth antennal segment, which is shorter, .128 + .08 mm; the unguis is different in shape, not being so thick or so blunt.

The hind femora are much shorter, 1.35–1.43 mm, as are also the hind tibiae, 2.28–2.59 mm. The tarsi are also shorter, those of the metathorax measuring only .228 mm.; antennal segments III, IV, and V vary within the limits of those of the true apterous viviparous female. The sensoria on the antennae are also similar; sensoria on the hind tibiae are similar to those of the oviparous female; the cornicles have a wider base.

#### OVIPAROUS FEMALE

*Size and general color.*—Length from vertex to tip of anal plate 3.2–3.64 mm. Color much the same as that of apterous viviparous female. However, some specimens are more black than brown, and such lack pulverulence and have a dull appearance due to abundant hair. The head and prothorax of black specimens are often light brown; the body is not highly arched.

*Head and appendages.*—Ocular tubercles poorly developed; width across eyes .78–.85 mm; antennal segments with the following proportional lengths: III, .74–.85 mm; IV, .257–.286 mm; V, .57–.386 mm; VI, .157 + .085 mm or .158 + .128 mm; unguis not so thick as that of apterous viviparous female; rostrum not reaching cornicles, median suture on head and thorax similar to females described; secondary sensoria distributed as follows: III, 0; IV, 0–1; V, 0–2; when present small.

*Thorax.*—Hind femora long, 1.57–1.78 mm; metathoracic tibiae, 2.71–2.84 mm; hind tibiae not disfigured by sensoria; sensoria not limited to upper half but few are present below the middle. The sensoria are irregular in shape and size, rather abundant, and hardly tuberculate. They are sometimes very difficult to determine because of the dark color of the tibiae. The hind tarsi are .328–.347 mm long.

*Abdomen.*—Base of cornicles measuring from .286 to .371 mm; posterior portion of abdomen not drawn out.

*Types.*—Allotype apterous male, taken October 12, 1951. Morphotype apterous viviparous female, taken September 16, 1951 (no sensoria on tibiae). Morphotype apterous oviparous female, taken October 12, 1951. All types deposited in the United States National Museum.

ICHTHYOLOGY.—Notes on the systematic status of four eel families.<sup>1</sup> WILLIAM A. GOSLINE, University of Hawaii. (Communicated by L. P. Schultz.)

Certain aspects of the classification of the eel families Derichthyidae, Simenchelidae, Ophichthidae, and Chilorhinidae are taken up here. The last is proposed as new.

DERICHTHYIDAE

The species *Derichthys serpentinus* was described by Gill (in Goode and Bean, 1895: 161, fig. 169), who erected a new genus, family, and the new order Carenycheli for it. However, subsequent authors have been unanimous in placing the species with other eels in the order Anguillida (or Apodes). Regan (1912: 386) has tentatively placed *Derichthys* in the Congridae, but Trewavas (1932: 641) and Beebe (1935) have retained a separate family for it. In the above works on *Derichthys* two points of disagreement have arisen: (1) whether the premaxillaries are separate from the vomer or whether they are fused with it, and (2) whether the frontals are ankylosed to form a single bone or whether they are separated by suture.

The type of *Derichthys serpentinus* consists of a skull 14 mm long, branchial arches, suspensoria, and pectoral girdles. In the skull the premaxillaries are ankylosed to one another but at present are free from the vomer. Gill stated that the premaxillaries were separated from the vomer by a suture, and I see no reason to doubt this despite the descriptions and figures of both Trewavas and Beebe. In fact, still another rather indefinite suture can also be made out in the type between the vomer and ethmoid.

A more unique feature among eels than the relationship between the premaxillary, ethmoid, and vomer in *Derichthys* is the maxillary articulation. This, instead of being at least in part medially with the ethmoid, is entirely forward, the front end of the maxillaries riding on sockets at either end of the transverse, premaxillary plate (Trewavas, 1932: 641, fig. 2).

As to the frontals, in the type specimen of *D. serpentinus* they are definitely ankylosed as stated by Beebe (1935: 9), and not paired as stated for *D. kempi* by Trewavas (1932: 641). This discrepancy, remarked upon elsewhere (Gosline, 1951a: 201), has been resolved by a recent letter from Trewavas. She writes: "I have

examined the type of *Derichthys kempi* (Norman) and find that I had not slit the skin far enough to expose the frontals properly. I have now made a bigger slit and lifted the muscles and their raphe from the bones and I find that the frontals are united."

*Benthenchelys*, placed by Fowler (1934: 267) and Beebe (1935: 3) in the Derichthyidae, appears to be a congrid. *Gorgosia*, also placed in the Derichthyidae by Meek and Hildebrand (1923: 133) and Beebe (1935: 3), seems to be more nearly related to *Heteroconger*, which again may provisionally be considered a congrid.

SIMENCHELIDAE

The anatomical characters of this family, based on *Simenchelys parasiticus*, have been treated by Gill (1890), Regan (1912: 381), and Jaquet (1920).

As in the Derichthyidae the two premaxillaries are ankylosed, but this premaxillary plate, the ethmoid, and the vomer are again united by suture (Fig. 1). However, unlike *Derichthys* the maxillaries articulate with both the premaxillary plate and the ethmoid. In fact the relationships of all these bones of the snout area are exactly the same as those illustrated for the larval *Anguilla* by Trewavas (1932: 640, fig. 1). I think it may be assumed from these bone arrangements in the above two families and in the larval *Anguilla* that the ankylosis of the two premaxillaries to one another takes place earlier in life and occurred earlier in eel evolution than the fusion that gave rise to the premaxillary-ethmo-vomerine plate.

Again the question of fused *vs.* paired frontals has arisen in the literature on *Simenchelys*. Regan has indicated that the frontals of the Simenchelidae are paired. However, Jaquet (1920: 14) states that the frontals are ankylosed, as indeed they are in National Museum specimens. Once again this dilemma has been resolved by Trewavas. She writes (*in litt.*): "In our collection there is one specimen (N. Atlantic) partially dissected and this was probably the source of Regan's information. There is a median ridge in the frontal region which Regan may have interpreted as a suture but I can find no separation of the two bones."

<sup>1</sup> Contribution No. 19, Hawaii Marine Laboratory.

The presence of scales in one of the two genera of Simenchelidae and the maintenance of the premaxillaries, ethmoid, and vomer as separate entities are certainly primitive for eels. However, the small transverse mouth with its short, deep maxillaries and dentaries seems to be unique in the order; whether these structures are primitive or specialized seems impossible to determine.

#### OPHICHTHIDAE

The osteology of several Hawaiian genera of ophichthids has been recently discussed (Gosline, 1951b). The present section deals with *Echelus myrus* from the Mediterranean. In view of the peculiarities of this eel and of the fact that recognition or non-recognition of the family name Echelidae depends upon the systematic position of *E. myrus* (since this is the type species of *Echelus*), it will be described and figured in some detail.

*External features.*—Head and body elliptical in cross section, somewhat higher than broad; head and trunk shorter than tail. Dorsal and anal low, continuous around tip of tail, the dorsal beginning somewhat behind middle of the pectoral. Pectoral well developed, with 16 rays. Lateral line of body extending from in front of gill openings nearly to tip of tail, with about 137 pores. Gill opening wide, below pectoral base. Snout more or less acutely pointed, its length equal to about 2 eye diameters. Eye well developed, its posterior border slightly ahead of rictus. Lower jaw inferior. Lips without folds, the upper somewhat fringed just behind anterior nostril; both lips with innumerable microscopic papillae. Anterior nostril in a tube; posterior nostril opening partly on the lateral, partly on the lower surface of the upper lip, the lower opening caused by a flap which covers the anterior two-thirds of the lateral opening (Fig. 2a). The pore system differs from that of other ophichthids examined (Gosline, 1952b) in lacking postorbital pores, a posterior supraorbital pore, an interorbital pore on the middorsal line, and a transverse series across the nape (Fig. 2a). Teeth multiserial on dentaries, maxillaries, premaxillary plate (fused premaxillaries), and vomer. Teeth on maxillaries and dentaries all small, conical, blunt, and non-depressible; those on the premaxillary similar but slightly larger and with a single somewhat enlarged, fixed tooth behind; those on vomer still larger, granular, rising from a subovate plate which is broadest behind center.

Color brown above, lighter below, with short, light bands on the head and several white spots on nape (these markings not indicated in Fig. 2a); dorsal and anal light anteriorly, with dark borders posteriorly.

*Lateral-line canals.*—The lateral-line canals of this species have been excellently described by Allis (1903: 131). Nothing need be added to this account except to point out that the course of these canals is about as in other ophichthids, even though several of the external pores found in other members of the family are not present in *Echelus*.

*Jaw structure.*—Lower jaw with the articular and angular fused as usually in eels. Premaxillaries ankylosed to one another and to the ethmovomer, the toothed surface of the premaxillary area forming an angle with the rest of the upper jaw (Fig. 2b). Anterior end of maxillaries articulating with the cranium at about the point of junction between the premaxillaries and vomer. Maxillary long, extending nearly to the articular-

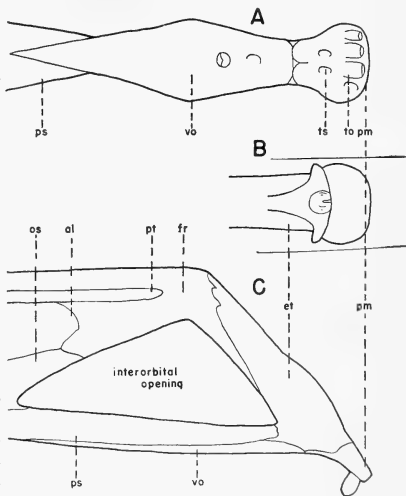

FIG. 1.—*Simenchelys parasiticus*: A, Ventral view of anterior end of skull; B, dorsal and somewhat anterior view of bones at tip of snout; C, lateral view of anterior end of skull; all  $\times 7\frac{1}{2}$ . (al, Alisphenoid; et, ethmoid; fr, frontal; os, orbitosphenoid; ps, parasphenoid; pm, premaxillary plate; pt, pterotic; to, tooth; ts, tooth socket (its tooth missing); and vo, vomer.)

angular, to which it is closely attached by ligament, bearing multiserial teeth for nearly its entire length. There is a strong preorbital strut, apparently cartilaginous, between the maxillary and the cranium (Fig. 2b). In many, if not all eels in which the maxillaries are long and used for biting or crushing, a strut is developed between the maxillary and the cranium for support of the former. In the ophichthid *Brachysomophis* such a strut develops behind the eye from the postorbital lateral-line canal ossicles (Gosline, 1952b). The development of this strut in *Brachysomophis* has apparently pushed the eye far forward of its normal position in eels. In the muraenid *Gymnothorax funebris*, according to Fig. 82 of Gregory (1933: 202), both an antorbital and a postorbital strut are developed. Thus, maxillary supports of this type appear to be functional adaptations appearing here and there where needed among eels. However, the origin of the antorbital strut, where present, is dubious. That it is not an expanded lacrymal is indicated by its failure to bear any lateral line canal; that it is not a prefrontal is suggested by its apparently cartilaginous nature in *Echelus*.

*Suspensorium*.—This structure is somewhat forwardly inclined, less so than in *Conger* but more than in other ophichthids. Palatopterygoid laminar, well developed for eels, adjoining the quadrate posteriorly.

*Opercular series*.—Opercle well developed below but more or less truncated above. Preopercle moderately developed for eels and closely appressed to the posterior edge of the hyomandibular. Subopercle made up largely of a branchiostegal-like bone which encircles the lower edge of the opercle. Interopercle well developed, largely underlying the preopercle.

*Gill arches*.—Tongue not free. Branchiostegal rays 15 on each side, those of the two sides overlapping below. Openings between the gill arches wide, except the last. Upper pharyngeal ovate, with numerous conical teeth.

*Cranium*.—The skull of *Echelus* is long and moderately low, with an interorbital opening that is longer than deep. Unlike other ophichthids examined, the skull of *Echelus* is abruptly truncate posteriorly with a prominent edge above, as in *Conger*. There is a slight, longitudinal, median crest running along the ankylosed frontals. The ethmoid sends a triangular wedge over the anterior end of the frontals. A well-developed otic bulla present.

*Axial skeleton*.—On one of the first vertebrae (the only one examined) there is no neural crest. In this character *Echelus* like other ophichthids differs from the Congridae.

*Pectoral girdle*.—This structure, together with the pectoral fins, is fully developed for eels, with 4 well-formed actinosts.

*Discussion of Echelus*.—In that *Echelus myrus* bears a number of structures showing a closer resemblance than any other ophichthid to the relatively unspecialized Congridae (from which the Ophichthidae was undoubtedly derived), it may be said to be a primitive member of its family. Characters on which this statement is based are: suspensorium somewhat forwardly inclined; branchiostegal rays relatively few; skull abruptly truncate posteriorly; and pectoral girdle with four actinosts.

Characters in which *Echelus* appears to differ both from the Congridae and from other ophichthids are: external pores of the lateral line system of the head reduced in number; a middorsal crest on the skull; and an antorbital stay between the maxillary and the cranium.

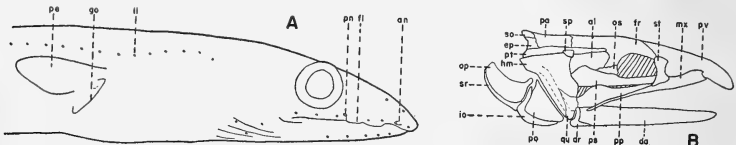

FIG. 2.—*Echelus myrus*: A, Lateral view of head region,  $\times 4/5$ ; B, lateral view of head skeleton (the teeth and branchial apparatus omitted),  $\times 4/5$ . (al, Alisphenoid; an, anterior nostril; ar, articular-angular; da, dentary; ep, epiotic; fl, flap covering the anterior section of the posterior nostril; fr, frontal; go, gill opening; hm, hyomandibular; io, interopercle; mx, maxillary; op, opercle; os, orbitosphenoid; pa, parietal; pe, pectoral fin; pn, posterior section of posterior nostril; po, preopercle; pp, palatopterygoid; ps, parasphenoid; pt, pterotic; pv, premaxillary-ethmovomerine plate; hu, quadrate; so, supraoccipital; sp, sphenotic; sr, subopercle; and st, preorbital strut.)

Characters in which *Echelus myrus* is similar to other ophichthids but differs from *Conger* are as follows: posterior nostril opening out on the ventrolateral surface of the upper lip; tongue not free; branchiostegal rays of the two sides overlapping along the midventral line; otic bulla developed; and neural crests apparently absent.

In summary, *Echelus myrus* appears, despite specializations, to be by far the most primitive (or generalized) ophichthid known. In fact, to a considerable degree it fills in the gap between the Ophichthidae and the Congridae.

Within the Ophichthidae, on zoological grounds as well as for convenience in identification, two subfamilies should in my opinion be recognized: (1) the Echelinae (called Myrophinae by Gosline in previous papers) with the dorsal and anal continuous around the tip of tail, and (2) the Ophichthinae with the tail protruding as a fleshy point. Both of these subfamilies contain very diverse eels and both include highly specialized members, but there is no known evidence that either is polyphyletic. Because of this diversity, the separation of *Echelus*, despite its peculiarities, from other fainted ophichthids—*Muraenichthys*, *Myrophis*, etc.—as a third subfamily seems inadvisable at the present time.

#### CHILORHINIDAE, n. fam.

The family name Chilorhinidae is here proposed for a group of three eel genera: *Chilorhinus* Lütken (1851), *Garmanichthys* Seale (1917, of which *Arenichthys* Beebe and Tee-Van, 1938, appears to be a synonym), and *Kaupichthys* Schultz (1943). These three genera have generally been placed with *Echelus*, *Muraenichthys*, etc., in the family Echelidae. However, osteological investigation has shown that *Kaupichthys* (Gosline, 1950) and *Chilorhinus* (Gosline, 1951a) belong in a very different family from *Muraenichthys* (which is an ophichthid, Gosline, 1951b). At the time the above genera were investigated specimens of *Echelus* were unavailable to me, and the name Echelidae was provisionally retained for the family represented by *Kaupichthys* and *Chilorhinus*. That this use of the name Echelidae is untenable has been shown by the previous section of the present paper. The name Chilorhinidae is therefor substituted.

Examination of a specimen of *Garmanichthys apterus* indicates that this genus also belongs in the Chilorhinidae.

Though phylogenetically distant as has been previously pointed out, the chilorhinids bear a

close superficial resemblance to the subfamily Echelinae of the Ophichthidae. The two groups can, however, be separated by a few minor superficial characters which may be tabulated as follows:

CHILORHINIDAE	ECHELINAE
Branchiostegal rays of the two sides (usually visible through the flesh of the "neck") never overlapping on the midventral line.	Branchiostegal rays of the two sides overlapping on the midventral line.
Vomerine teeth biserial, the two rows widely separated.	Vomerine teeth, if present, uniserial, in two or more irregular rows, or in a broad band.
Fin rays at the tip of the tail longer than the dorsal and anal rays preceding them.	Fin rays at the tip of tail usually shorter than the dorsal and anal rays preceding them.

The three known genera of Chilorhinidae may be separated as follows:

- 1a. Pectorals present, well developed (Indo-West-Pacific).....*Kaupichthys*
- 1b. Pectorals rudimentary or absent.
  - 2a. Lower lip with a well-developed flap on either side; snout broader than long (West Indies and Hawaii).....*Chilorhinus*
  - 2b. Lower lip without a downwardly-folded flap on either side; snout longer than broad (includes *Arenichthys*; both sides of tropical America).....*Garmanichthys*

#### EEL CLASSIFICATION

Recent examination of the osteology of certain eels (Gosline, 1950, 1951a, 1951b, and the present paper) has necessitated a shift in the systematic position of several eel families. Yet much remains to be done before any basic understanding of eel classification can be attained. Not only are we ignorant of the phylogenetic relationships of many eel groups and of the order Anguillida itself, but the present delimitation of many eel families is awry. On the one hand families have been erected for certain species on insufficient osteological evidence; on the other the Congridae continues to form a dumping ground for all sorts of creatures (including, as my contribution, *Benthenchelys*, *Gorgasia*, and the Macrocephenchelidae). At present then, it is impossible to do more than add to the classification of eels set up by Regan (1912).

So far as I can tell, this foundation remains sound; at the very least, a better one has never been proposed. The changes in classification necessitated by the recent work cited above can be integrated into the synopsis of eel families given by Regan (1912: 379) and amended by Trewavas (1932: 656) as follows:

- 1a. Caudal fin well developed and free from dorsal and anal. (A fossil group.) . . . . . URENCHELIDAE
- 1b. Caudal fin, if present, small, and generally continuous with the dorsal and anal.
  - 2a. Frontals divided by suture, at least posteriorly.
  - 3a. Frontals divided by a suture for their entire length.
  - 4a. Jaws not produced.
    - 5a. No expanded auditory bulla present  
ANGUILLIDAE, XENCONGRIDAE, MYROCONGRIDAE, and MURAENIDAE
    - 5b. Prootic and basioccipital forming an enlarged auditory bulla around a large otolith.
    - 6a. Posterior nostril labial  
CHILORHINIDAE
    - 6b. Posterior nostril on cheek  
HETERENCHELIDAE and MORINGUIDAE
  - 4b. Jaws produced. . . . . SERRIVOMERIDAE
- 3b. Frontals ankylosed anteriorly  
NEMICHTHYIDAE and CYEMIDAE
- 2b. Frontals ankylosed for their entire length.
  - 7a. Maxillaries articulating only with lateral tips of premaxillaries. . . . . DERICHTHYIDAE
  - 7b. Maxillaries articulating in part or entirely with ethmoid.
  - 8a. Jaws strong; suspensorium vertical or directed obliquely forward.
    - 9a. Caudal vertebrae without transverse processes above haemal arches.
      - 10a. Maxillary articulating with ethmoid at some distance from end of snout. . . . . MURAENOSOCIIDAE and NEENCHELIDAE
      - 10b. Maxillary articulating with ethmoid near tip of snout.
        - 11a. Mouth a small, transverse slit across front of head  
SIMENCHELIDAE
        - 11b. Gape large; jaws long  
NETTASTOMIDAE and NESSORHAMPHIDAE
    - 9b. Caudal vertebrae with transverse processes above the haemal arches.
      - 12a. Posterior nostril superior or lateral. (The Heterocongridae and Macrocephenchelidae are provisionally included here.) . . . . . CONGRIDAE
      - 12b. Posterior nostril labial. (Includes Echelinae.) . . . . . OPHICHTHYIDAE
  - 8b. Jaws slender; suspensorium directed obliquely backward. . . . . LYPHIDAE, DYSSOMIDAE, and SYNAPHOBANCHIDAE

I wish to thank Dr. L. P. Schultz for permission to examine skeletal material in the U. S. National Museum of *Simenchelys* and *Derichthys* reported on by Gill (1890 and, in Goode and Bean, 1895, respectively), together with a preserved specimen of *Garmanichthys apterus*. Through the kindness of Dr. G. S. Myers and J. Böhle, a Stanford University specimen of *Echelus myrus* has been lent me; as this appears to be the only specimen of *Echelus* in America, I am particularly indebted to Dr. Myers for permission to dissect it partially. I also wish to thank Dr. E. Trewavas of the British Museum for examining specimens of *Derichthys* and *Simenchelys* for me.

## LITERATURE CITED

- ALLIS, EDWARD PHELPS, JR. *The lateral sensory system of the Muraenidae*. Int. Monatschr. Anat. und Physiol. **20**: 125-170, pls. 6-8. 1903.
- BEEBE, WILLIAM. *Deep-sea fishes of the Bermuda Oceanographic Expeditions, No. 1: Family Derichthyidae*. Zoologica **20**(1): 1-23, 9 figs. 1935.
- BEEBE, WILLIAM, and TEE-VAN, JOHN. *Eastern Pacific Expeditions of the New York Zoological Society, XV: Seven new marine fishes from Lower California*. Zoologica **23**: 299-312, 3 pls., 5 figs. 1938.
- FOWLER, HENRY WEED. *Descriptions of new fishes obtained 1907 to 1910, chiefly in the Philippine Islands and adjacent seas*. Proc. Acad. Nat. Sci. Philadelphia **85**: 233-367, 117 figs. 1934.
- GILL, THEODORE N. *The osteological characters of the family Simenchelidae*. Proc. U. S. Nat. Mus. **13**: 239-243. 1890.
- GOODE, GEORGE BROWN, and BEAN, TARLETON H. *Oceanic ichthyology*. U. S. Nat. Mus. Spec. Bull. 2: i-xxv + 1-553 and atlas of i-xxiii + 1-26, 123 pls. 1895.
- GOSLINE, WILLIAM A. *The osteology and relationships of the echelid eel, Kaupichthys diodontus*. Pacific Sci. **4**: 309-314, 7 figs. 1950.
- . *Chilorhinus brocki, a new echelid eel from Hawaii, with notes on the classification of the order Anguillida*. Copeia, 1951: 195-202, 1 fig. 1951a.
- . *The osteology and classification of the ophichthid eels of the Hawaiian Islands*. Pacific Sci. **5**: 298-320, 18 figs. 1951b.
- GREGORY, WILLIAM K. *Fish skulls: a study of the evolution of natural mechanisms*. Trans. Amer. Philos. Soc. (new ser.) **23**(2): i-vii + 75-481, 302 figs. 1933.
- JAQUET, MAURICE. *Contribution à l'anatomie du Simenchelys parasiticus Gill*. Resultats des Campagnes Scientifiques, Monaco, **56**: 1-77, 5 pls. 1920
- LÜTKEN, CHR. *Ueber die Stellung der Nasenlöcher bei den Ophisurus-Arten und den mit ihnen verwandten Gattungen aus der Familie der Aale*. Arch. Naturg. **18**(1): 255-276. 1851.
- MEEK, SETH E., and HILDEBRAND, SAMUEL F. *The marine fishes of Panama*. Publ. Field Mus. Nat. Hist., zool. ser., **15**(1): i-xi + 1-330, pls. 1-24. 1923.

REGAN, C. TATE. *The osteology and classification of the teleostean fishes of the order Apodes*. Ann. Mag. Nat. Hist. (8)10: 377-387, 2 figs. 1912.

SCHULTZ, LEONARD P. *Fishes of the Phoenix and Samoan Islands* . . . U. S. Nat. Mus. Bull 180: i-x + 1-316, 9 pls., 27 figs. 1943.

SEALE, ALVIN. *New species of apodal fishes*. Bull. Mus. Comp. Zool. 61(4): 79-94. 1917.

TREWAVAS, ETHELWYNN. *A contribution to the classification of the fishes of the order Apodes, based on the osteology of some rare eels*. Proc. Zool. Soc. London, 1932: 639-659, 4 pls., 9 figs. 1932.

## PROCEEDINGS OF THE ACADEMY

### 452D MEETING OF BOARD OF MANAGERS

The 452d meeting of the Board of Managers held in the Cosmos Club on January 14, 1952, was called to order at 8:03 p.m. by President-Elect WALTER RAMBERG. Others in attendance were: H. S. RAPPLEYE, J. A. STEVENSON, H. A. REHDER, CHARLES DRECHSLER, W. F. FOSHAG, A. T. MCPHERSON, C. F. W. MUESEBECK, SARA E. BRANHAM, J. J. FAHEY, E. H. WALKER, WM. A. DAYTON, C. A. BETTS, R. S. DILL, A. M. GRIFFIN, FLOYD HOUGH, M. A. MASON, F. M. DEFANDORF, and, by invitation, MARGARET PITTMAN, J. R. SWALLEN, G. P. WALTON, B. D. VAN EVERA, and G. H. COONS.

Chairman WALTON presented the report of the Committee on Awards for Scientific achievement. MILTON SEYMOUR SCHECHTER, of the Bureau of Entomology and Plant Quarantine, was nominated for the Award in the Physical Sciences; EDWARD WILLIAM BAKER, Bureau of Entomology and Plant Quarantine, for the Award in the Biological Sciences; and MAX A. KOHLER, of the Weather Bureau, for the Award in the Engineering Sciences. For the Teaching of Science, the first award of its kind to be requested of the Board since this award was approved in principle in 1950, the Committee recommended that in lieu of the regular award, which bears the age limitation of 40, a special award be presented to HOWARD B. OWENS, biology teacher in the Hyattsville High School, for his outstanding teaching and for his work in arousing the enthusiasm of the students who come in contact with him. The Managers approved the granting of the awards as recommended.

Chairman MASON of the Committee on Encouragement of Science Talent spoke of activities in connection with the forthcoming 4th District Talent Search, the National Science Talent Fair, and the 5th Annual Science Fair to be held in Washington. Funds accruing from the Academy-sponsored benefit showing of the film Kon-Tiki should ease the financial problems that arise on

these occasions where there is no obvious source of financial support.

The Secretary read a letter dated January 4, 1952, from N. R. Ellis, secretary-treasurer of the Society for Experimental Biology and Medicine, expressing the interest of this Society in becoming affiliated with the Academy. It was moved and approved that the President of the Academy appoint a special committee to consider the application and bylaws of the Society and make suitable recommendations to the Board.

The Secretary read a letter from the business manager of the American Association for the Advancement of Science, listing the following amounts available for Grants-in-Aid:

Balance for 1950.....	\$4.50
For 1951.....	249.00
For 1952.....	246.00

making a total presently available of \$499.50. The small amount remaining for 1950 will not be available unless expended before December 31, 1952.

Deaths were reported of OSCAR B. HUNTER, SR., on December 19, 1951. and RUFUS H. SARGENT on December 28, 1951.

On request and recommendation of the Treasurer, BERTRAND L. JOHNSON, who will retire in 1952 from the U. S. Bureau of Mines, was transferred to the retired list as of December 31, 1952.

Letters of resignation were received from MAXWELL M. KNECHTEL, WILLIAM VOGT, and L. E. WHITTEMORE. Their resignations were approved as of December 31, 1951.

The Treasurer reported that his books had been audited for 1951 and the securities had been examined by the auditing committee.

Senior Editor Drechsler gave a statistical report on the content of the 1951 volume of the JOURNAL and indicated that the net cost would be \$6,500.76.

The meeting was adjourned at 9:15 p.m.

F. M. DEFANDORF, *Secretary*

## Obituary

MAURICE ISADORE SMITH was born November 17, 1887, in Russia and became a naturalized citizen of the United States at the age of 10. He attended school in New York, receiving his B.S. degree from the College of the City of New York in 1909. From there he went on to study medicine at Cornell University Medical School and obtained his medical degree in 1913. His early professional experience was in teaching, first as instructor of pharmacology at the University of Michigan and later as professor of pharmacology at the University of Nebraska.

In 1920, Dr. Smith joined the staff of the pharmacology division of the Hygienic Laboratory (the present National Institutes of Health) of the Public Health Service. Thereafter, except for a brief period as director of the Glandular and Pharmaceutical Department of Lederle Antitoxin Laboratories, Dr. Smith devoted his entire professional career to Government service. Judged by the number and quality of his publications over a period of 30 years, he found it a satisfying and productive field of labor. During the greater part of this time, Dr. Smith served as physiologist representative on the Basic Science Board of the Commission for Medical Licensure of the District of Columbia, giving to this activity the same conscientious devotion he gave to his research projects.

Aside from the high quality of Dr. Smith's work in the field of pharmacology, one is impressed by his versatility. In addition to pharmacological and closely related studies we find him contributing to advancement in the field of surgical shock, the sulfones, drug standardization, selenium toxicology, chemotherapy, vitamins, antibiotics, and tuberculosis. Perhaps the best example of Dr. Smith's interest in different fields of research is to be found in his work on Jamaica-ginger paralysis, the "jake paralysis" that afflicted many thousands of people in midwestern and southwestern States early in 1931. After his studies had shown that this condition was due to one of the several esters of tricresyl phosphate contained in an adulterated extract of ginger sold

for beverage purposes, the investigation led him directly into the field of epidemiology. He made a trip into the geographic area where there was a particularly well defined outbreak of the disease and made an investigation of an epidemiological character that would have done credit to the scientist specializing in epidemiologic studies.

During the last decade of his professional career, Dr. Smith's chief interest was the chemotherapy of tuberculosis. His research in this field dates back to 1922 with the publication of several papers on the chemotherapy of acridine dyes; in 1940 he initiated an extensive program in the development of new sulfone derivatives for treatment in experimental tuberculosis. With the development of streptomycin he undertook a series of studies in which it was demonstrated that combined therapy with a sulfone gave potentiation to tuberculostatic action. In addition he carried on a series of studies on the metabolism of the tubercle bacillus and the problem of acquired resistance during treatment. The literature on the chemotherapy of tuberculosis is substantially enriched by the many contributions prepared and directed by Dr. Smith.

His range of interests is reflected in the number of scientific societies of which he was a member—among others the American Association for the Advancement of Science, Society for Experimental Biology and Medicine, Trudeau Society, Society of Pharmacology and Experimental Therapeutics, Physiological Society, and the Washington Academy of Sciences.

Those who knew Dr. Smith best would agree that he was a careful, gifted scientific worker, an inspiring teacher, a faithful, devoted public servant, a helpful friend, and a stimulating associate.

Dr. Smith died on January 26, 1951. He is survived by his widow, Mrs. Rebecca M. Smith, of Bethesda, Md., and two sons, Dr. Charles E. Smith, of the U. S. Public Health Service, and Matthew S. Smith, a graduate in engineering specializing in the field of aeronautical design.

GEORGE W. McCoy



## Officers of the Washington Academy of Sciences

*President*.....WALTER RAMBERG, National Bureau of Standards  
*President-elect*.....F. M. SETZLER, U. S. National Museum  
*Secretary*.....F. M. DEFANDORF, National Bureau of Standards  
*Treasurer*.....HOWARD S. RAPPLEYE, U. S. Coast and Geodetic Survey  
*Archivist*.....JOHN A. STEVENSON, Plant Industry Station  
*Custodian and Subscription Manager of Publications*  
 HARALD A. REHDER, U. S. National Museum

### *Vice-presidents Representing the Affiliated Societies:*

Philosophical Society of Washington.....A. G. McNISH  
 Anthropological Society of Washington.....WALDO R. WEDEL  
 Biological Society of Washington.....HUGH T. O'NEILL  
 Chemical Society of Washington.....JOHN K. TAYLOR  
 Entomological Society of Washington.....FREDERICK W. POOS  
 National Geographic Society.....ALEXANDER WETMORE  
 Geological Society of Washington.....A. NELSON SAYRE  
 Medical Society of the District of Columbia.....FRED O. COE  
 Columbia Historical Society.....GILBERT GROSVENOR  
 Botanical Society of Washington.....LEE M. HUTCHINS  
 Washington Section, Society of American Foresters.....WILLIAM A. DAYTON  
 Washington Society of Engineers.....CLIFFORD A. BETTS  
 Washington Section, American Institute of Electrical Engineers.....A. H. SCOTT  
 Washington Section, American Society of Mechanical Engineers.....RICHARD S. DILL  
 Helminthological Society of Washington.....L. A. SPINDLER  
 Washington Branch, Society of American Bacteriologists.....ANGUS M. GRIFFIN  
 Washington Post, Society of American Military Engineers.....FLOYD W. HOUGH  
 Washington Section, Institute of Radio Engineers.....HERBERT G. DORSEY  
 District of Columbia Section, American Society of Civil Engineers  
 MARTIN A. MASON

### *Elected Members of the Board of Managers:*

To January 1953.....C. F. W. MUESEBECK, A. T. MCPHERSON  
 To January 1954.....SARA E. BRANHAM, MILTON HARRIS  
 To January 1955.....ROGER G. BATES, W. W. DIEHL

*Board of Managers*.....All the above officers plus the Senior Editor

*Board of Editors and Associate Editors*.....[See front cover]

*Executive Committee*....WALTER RAMBERG (chairman), F. M. SETZLER, H. S. RAPPLEYE,  
 WILLIAM A. DAYTON, F. M. DEFANDORF

*Committee on Membership*...E. H. WALKER (chairman), M. S. ANDERSON, CLARENCE, COT-  
 TAM, R. C. DUNCAN, G. T. FAUST, I. B. HANSEN, FRANK KRACEK, D. B. JONES, DORO-  
 THY NICKERSON, REECE I. SAILER, LEO A. SHINN, F. A. SMITH, HEINZ SPECHT, H. M.  
 TRENT, ALFRED WEISSLER

*Committee on Meetings*....H. W. WELLS (chairman), Wm. R. CAMPBELL, W. R. CHAP-  
 LINE, D. J. DAVIS, H. G. DORSEY, O. W. TORRESON

*Committee on Monographs* (W. N. FENTON, chairman):

To January 1953.....R. W. IMLAY, P. W. OMAN  
 To January 1954.....S. F. BLAKE, F. C. KRACEK  
 To January 1955.....W. N. FENTON, ALAN STONE

*Committee on Awards for Scientific Achievement* (J. R. SWALLEN, general chairman):

*For Biological Sciences*.....J. R. SWALLEN (chairman), L. M. HUTCHINS,  
 MARGARET PITTMAN, F. W. POOS, L. P. SCHULTZ

*For Engineering Sciences*.....R. C. DUNCAN (chairman), A. C. FIELDNER,  
 WAYNE C. HALL, J. W. MCBURNEY, O. S. READING, H. L. WHITTEMORE

*For Physical Sciences*.....L. A. WOOD (chairman), P. H. ABELSON,  
 F. S. DAFT, GEORGE W. IRVING, JR., J. H. McMILLEN

*For Teaching of Science*.....M. A. MASON (chairman), F. E. FOX, M. H. MARTIN

*Committee on Grants-in-aid for Research*.....L. E. YOCUM (chairman), H. N. EATON,  
 K. F. HERZFELD

### *Committee on Policy and Planning:*

To January 1953.....W. A. DAYTON (chairman), N. R. SMITH  
 To January 1954.....H. B. COLLINS, JR., W. W. RUBEY  
 To January 1955.....L. W. PARR, F. B. SILSBEE

*Committee on Encouragement of Science Talent* (A. T. MCPHERSON, chairman):

To January 1953.....A. H. CLARK, F. L. MOHLER  
 To January 1954.....J. M. CALDWELL, W. L. SCHMITT  
 To January 1955.....A. T. MCPHERSON, W. T. READ

*Representative on Council of A. A. A. S.*.....F. M. SETZLER

*Committee of Auditors*.....C. L. GAZIN (chairman), LOUISE M. RUSSELL, D. R. TATE

*Committee of Tellers*...GEORGE P. WALTON (chairman), GEORGE H. COONS, C. L. GARNER

## CONTENTS

	Page
METEOROLOGY.—On the variation of the average daily temperature at Washington, D. C. RICHMOND T. ZOCH.....	105
GEOLOGY.—Brightseat formation, a new name for sediments of Paleocene age in Maryland. ROBERT R. BENNETT and GLENN GENE COLLINS.....	114
PALEONTOLOGY.—Nomenclatural notes on carditids and lucinids. A. CHAVAN.....	116
BOTANY.—New species of grasses from Venezuela. AGNES CHASE....	122
ENTOMOLOGY.—Notes on Bruchidae affecting the Anacardiaceae, including the description of a new genus. JOHN COLBURN BRIDWELL.	124
ENTOMOLOGY.—Descriptions and notes on two rare species of Aphididae. F. C. HOTTES.....	127
ICHTHYOLOGY.—Notes on the systematic status of four eel families. WILLIAM A. GOSLINE.....	130
PROCEEDINGS: THE ACADEMY.....	135
OBITUARY: Maurice Isadore Smith.....	136

# JOURNAL

OF THE

# WASHINGTON ACADEMY OF SCIENCES

## BOARD OF EDITORS

WILLIAM F. FOSHAG  
U.S. NATIONAL MUSEUM

J. P. E. MORRISON  
U.S. NATIONAL MUSEUM

JOHN C. EWERS  
U.S. NATIONAL MUSEUM

## ASSOCIATE EDITORS

F. A. CHACE, JR.  
BIOLOGY

MIRIAM L. BOMHARD  
BOTANY

J. I. HOFFMAN  
CHEMISTRY

R. K. COOK  
PHYSICS AND MATHEMATICS

T. P. THAYER  
GEOLOGY

PHILIP DRUCKER  
ANTHROPOLOGY

C. W. SABROSKY  
ENTOMOLOGY

PUBLISHED MONTHLY

BY THE

WASHINGTON ACADEMY OF SCIENCES

MOUNT ROYAL & GUILFORD AVES.

BALTIMORE, MARYLAND

Entered as second class matter under the Act of August 24, 1912, at Baltimore, Md.  
Acceptance for mailing at a special rate of postage provided for in the Act of February 28, 1925.  
Authorized February 17, 1949

## Journal of the Washington Academy of Sciences

This JOURNAL, the official organ of the Washington Academy of Sciences, publishes: (1) Short original papers, written or communicated by members of the Academy; (2) proceedings and programs of meetings of the Academy and affiliated societies; (3) notes of events connected with the scientific life of Washington. The JOURNAL is issued monthly. Volumes correspond to calendar years.

*Manuscripts* may be sent to any member of the Board of Editors. It is urgently requested that contributors consult the latest numbers of the JOURNAL and conform their manuscripts to the usage found there as regards arrangement of title, subheads, synonymies, footnotes, tables, bibliography, legends for illustrations, and other matter. Manuscripts should be typewritten, double-spaced, on good paper. Footnotes should be numbered serially in pencil and submitted on a separate sheet. The editors do not assume responsibility for the ideas expressed by the author, nor can they undertake to correct other than obvious minor errors.

*Illustrations* in excess of the equivalent (in cost) of one full-page halftone are to be paid for by the author.

*Proof*.—In order to facilitate prompt publication one proof will generally be sent to authors in or near Washington. It is urged that manuscript be submitted in final form; the editors will exercise due care in seeing that copy is followed.

*Unusual cost* of foreign, mathematical, and tabular material, as well as alterations made in the proof by the author, may be charged to the author.

*Author's Reprints*.—Reprints will be furnished in accordance with the following schedule of prices (approximate):

Copies	4 pp.	8 pp.	12 pp.	16 pp.	20 pp.	Covers
100	\$3.25	\$6.50	\$ 9.75	\$13.00	\$16.25	\$3.00
200	6.50	13.00	19.50	26.00	32.50	6.00
300	9.75	19.50	29.25	39.00	48.75	9.00
400	13.00	26.00	39.00	52.00	65.00	12.00

*Subscriptions* or requests for the purchase of back numbers or volumes of the JOURNAL or the PROCEEDINGS should be sent to HAROLD A. REHDER, Custodian and Subscription Manager of Publications, U. S. National Museum, Washington 25, D. C.

*Subscription Rates* for the JOURNAL.—Per year..... \$7.50

Price of back numbers and volumes:	Per Vol.	Per Number
Vol. 1 to vol. 10, incl.—not available.*	—	—
Vol. 11 to vol. 15, incl. (21 numbers per vol.)	\$10.00	\$0.70
Vol. 16 to vol. 22, incl. (21 numbers per vol.)	8.00	0.60
Vol. 23 to current vol. (12 numbers per vol.)	7.50	0.90

\* Limited number of complete sets of the JOURNAL (vol. 1 to vol. 41, incl.) available for sale to libraries at \$348.50.

MONOGRAPH No. 1, "The Parasitic Cuckoos of Africa," by Herbert Friedmann..	\$4.50
PROCEEDINGS, vols. 1-13 (1899-1911) complete.....	\$25.00
Single volumes, unbound.....	2.00
Single numbers.....	.25

*Missing Numbers* will be replaced without charge provided that claim is made to the Treasurer within 30 days after date of following issue.

*Remittances* should be made payable to "Washington Academy of Sciences" and addressed to the Treasurer, H. S. RAFFLEYE, 6712 Fourth Street, N.W., Washington 12, D.C.

*Exchanges*.—The Academy does not exchange its publications for those of other societies.

# JOURNAL OF THE WASHINGTON ACADEMY OF SCIENCES

VOLUME 42

May 1952

No 5

SYSTEMATIC ZOOLOGY.—*Nomenclature and grammar*. CESARE EMILIANI, University of Chicago.<sup>1</sup> (Communicated by James Steele Williams.)

Today, more than ever before, a student of biological sciences finds it difficult to follow both nomenclatural and grammatical rules. Increasing disregard for the classical languages, particularly in the United States, Russia, and the Orient, is largely responsible.

Taxonomic rules state in essence that:

1. Nomenclature must use the Latin language.

2. An organism is known by a generic and a specific<sup>2</sup> name (possibly also by a sub-generic and a subspecific name).

3. These names may be natural or artificial words.

4. Generic names must be used as substantives.

5. Specific adjectives (and presumably participles and pronouns) must conform in gender to the generic names with which they are associated.

Three main problems originate from these rules:

1. Substantives, adjectives, participles, and pronouns; other parts of speech; and artificial words must be distinguished.

2. Gender of generic substantives must be determined.

3. Specific adjectives, participles, and pronouns must be given the proper gender endings.

Several authors in recent years have proposed different solutions of these problems. McAtee (1928) suggested that "generic and subordinate names . . . shall be regarded

<sup>1</sup> The writer is indebted to Dr. J. Marvin Weller, of the University of Chicago, for revising the manuscript.

<sup>2</sup> The term *specific* is used here and in the following as equivalent to *trivial*. The term *specific* is preferred because of its relations to the well-accepted terms *generic* and *subspecific*. To designate the whole name of a species (*generic* + *specific* names) the term *species name* should be used.

. . . as arbitrary combinations of letters" and, therefore, except for proved typographical errors, remain as the first author used them. Guba and Linder (1932) proposed to keep unchanged the original spelling even if erroneous. Blackwelder (1941) repeated suggestions previously made by Casey (1890) for determining the gender of generic names by their endings and published lists of endings for these determinations. Richter recommended that all specific adjectives and all specific substantives with *-us* (or *-er*), *-a*, and *-um* endings, should be used in the feminine form (Richter, 1942; Weller, 1950; Bartenstein, 1950). Other authors have made occasional reference to these problems, often publishing partly incorrect statements. Thus Baker (1929) reported that *Zonitoides* should be masculine; Macfadyen and Kenny (1934) and Thalmann (1950) classified as masculine all names ending in *-ides*, *-ites*, and *-oides*; and Bartenstein (1950) concluded that endings in *-ites*, *-on*, and *-opsis* indicate the masculine.

Some of the suggestions that have been made (McAtee, 1928; Guba and Linder, 1932), if accepted, would increase the difficulties of nomenclature because both specific names and their particular endings would have to be remembered. Blackwelder's lists may be misleading, because there are exceptions to all such generalities. Richter has not solved these problems either because substantives, adjectives, participles, and pronouns must still be identified and proper handling of the feminine forms is required. Also his suggestion that all substantives which may end in *-us* (or *-er*), *-a*, and *-um* be used in the feminine form, if applied to words that are exclusively substantives, would be likely to create new names and thus add to the confusion.

All the foregoing suggestions aim at avoiding the difficulties of Latin grammar. It is the opinion of the writer that, if the Latin language is used, it is impossible to ignore its rules; and that strict observance of these rules is really not so difficult and offers the most convenient solution to the whole problem.

Students are inclined to spend much time checking earlier authors to resolve orthographic doubts. A quicker and safer course is to consult good Latin and Greek dictionaries. As shown below, this can be done easily by persons totally ignorant of the classics. A rational use of dictionaries and the few suggestions that follow, will help to solve most controversial issues definitely. The exceptions that may occur do not impair the procedure.

## GENERIC NAME

### I. IF GENERIC NAME IS A SUBSTANTIVE

1. Simple substantives. Ex.: *Arca*, *Asperitas*, *Battus*, *Chiton*, *Lagena*, *Murex*, *Oenone*, *Venus*. Consult dictionaries for gender determinations.

2. Compound substantives. Ex.: *Aulocaulis*, *Cyphosoma*, *Dictyonema*, *Homotrema*, *Orthoceras*, *Tetrataxis*. Determine the genders of the last parts (-*caulis*, -*soma*, -*nema*, etc.) by looking them up in the dictionaries.

3. Simple or compound substantives with diminutive suffixes -*lus*, -*ulus*, -*culus*, -*unculus*, -*inus*, -*ellus*, -*illus*, -*iolus*, and their feminine (-*a*) and neuter (-*um*) forms. Ex.: *Atrypina*, *Atrypella*, *Avicula*, *Modiolus*, *Pectunculus*, *Scutella*, *Vulvulina*, *Asonoina*, *Cushmanella*, *Haekelina*, *Paalzowella*, *Schubertella*, *Wiesnerella*. Gender is determined by endings (-*us*, m; -*a*, f.; -*um*, n.). Many words having these endings, however, are not diminutive forms, and dictionaries should be consulted in all cases of doubt. Barbaric names (*Asanoina*, *Cushmanella*, *Haekelina*, etc.) should be easily recognizable.

### II. IF GENERIC NAME IS A SUBSTANTIVIZED ADJECTIVE OR PARTICIPLE

1. Simple or compound adjectives and participles with three endings (in Latin mostly: -*us* or -*er*, m.; -*a*, f.; -*um*, n.; in Greek mostly: -*os*, m.; -*η*, f.; -*ov*, n.). Ex.: adjectives: *Arctica*, *Blainvillea*, *Bronteus*, *Carpenteria*, *Entosolenia*, *Flintia*, *Indiana*, *Metagraulos*, *Michelinia*, *Viviparus*; par-

ticiples: *Corrugata*, *Composita*, *Optatus*. Gender is determined by ending.

2. Simple or compound adjectives with two endings (in Latin: -*is*, m. and f.; -*e*, n.; in Greek: -*os*, -*ov*, -*os*, -*ηs*, -*is*, -*us*, m. and f.; -*ov*, -*ov*, -*es*, -*i*, -*v*, n.). Ex.: *Daiphron*, *Epelys*, *Monoceros*, *Vitalis*. These names have one ending for masculine and feminine, and another for neuter. Note that since the Greek endings -*ov*, -*ov*, and -*ηs*, -*es*, are transliterated into Latin simply as -*on* and -*es*, transliterated names of this type do not indicate any particular gender.

3. Simple or compound adjectives and participles with one ending (various types). Many of these names are indifferently masculine, feminine, or neuter (*Vagans*, *Anomalinoidea*, and practically all names in -*oides*). Others may be masculine or feminine (*Apus*, *Harpax*, *Monyx*, *Calliops*, *Ogygopsis*, most classical and all post-classical names ending in -*ops* and -*opsis* derived from the Greek words *ὄψ*, *ὠψ*, and *ὄψις*, meaning "look, appearance"). A few are exclusively masculine (*Gennadas*) or feminine (*Hyalopsis*, *Monopsis*). It should be noted that some names ending in -*oides* and several derived from *ὄψ*, *ὠψ*, and *ὄψις* are substantives and, therefore, have determinate genders (*Ooides*, *Cyclops*, *Diopsis*). On the other hand, many names with the endings -*ops* and -*opsis* (*Penelops*, *Scalops*, *Lycopsis*) are substantives having different etymologies and genders (usually masculine, but also feminine). Use of dictionaries is necessary to distinguish these.

Adjectives of type 2 and 3, and participles of type 3, have caused the greatest confusion in nomenclature, because their genders are very often indeterminate. It would be most helpful if these were established by convention. This can be done easily if these names are thought of as referring to the word *forma* (or *concha* for shelled animals). Thus their genders would be established as feminine. The same procedure could be applied to substantives that may be either masculine or feminine (*Pais*, *Vindex*), thus considering them as feminine. Names that may be either substantives or adjectives (*Tribon*) should be interpreted as substantives, to agree with the substantival character of the generic name.

### III. IF GENERIC NAME IS ANOTHER PART OF SPEECH

1. Pronouns. Ex.: *Mea*, *Quisque*, *Utra*. Most pronouns have different forms for different genders.

2. Verbs, participles excepted, and other parts of speech. Ex.: *Vireo*, *Extra*, *Ita*, *Parce*. All these names should be considered neuter.

#### IV. IF GENERIC NAME IS AN ARTIFICIAL, BARBARIC, OR MISPELLED WORD

1. Artificial combinations of letters Ex.: *Aa*, *Neda*, *Nonion*, *Salifa*, *Torix*.

2. Barbaric unlatinized names. Ex.: *Macao*, *Scalez*, *Vankoro*.

3. Names with misspelled endings. Ex.: *Bato-crinus* (for *Batocrinon*), *Graphiodactyllis* (for *Graphiodactylus*).

The genders of these names can be established as masculine or neuter if they have obvious masculine or neuter endings. All others, including barbaric names, may be considered as feminine (in analogy to the suggestion in II, 3 above).

### SPECIFIC NAMES

#### I. IF SPECIFIC NAME IS A SUBSTANTIVE

Specific substantives may be either in the nominative singular in apposition to the generic name (*Retepora archimedes*), or in the genitive as a possessive term (*Rotalia beccarii*).

#### II. IF SPECIFIC NAME IS AN ADJECTIVE OR A PARTICIPLE

The gender of a specific adjective or participle must conform with the gender of the generic name. Simple instructions on how to select proper gender endings are given below. It should be noted that accordance must be observed also with compound names like *acutangulus*, which, if used with a feminine generic name, becomes *acutangula*, or with a neuter name *acutangulum* (cfr. *semicanis*, -e; *semicirculus*, -a, -um; *sexangulus*, -a, -um; *unicalamus*, -a, -um; *unimanus*, -a, -um; etc.).

Names that may be either substantives or adjectives should be considered adjectives in agreement with the adjectival character of the specific name.

#### III. IF SPECIFIC NAME IS ANOTHER PART OF SPEECH

1. Pronouns. Pronouns that have different forms for different genders should follow accordance rules (*Spondylospira alia*).

2. Verbs, participles excluded, and other parts of speech. All these names should be considered invariably as appositions.

#### IV. IF SPECIFIC NAME IS AN ARTIFICIAL, BARBARIC, OR MISPELLED WORD

Names of this type similar to those used for generic names have been employed for species. They should be treated invariably as appositions.

### USE OF LATIN AND GREEK DICTIONARIES

#### I. LATIN AND GREEK ALPHABETS

To consult Latin and Greek dictionaries it is necessary to know the Greek equivalents of Latin letters. These are given below:

α	a	ι	i	ρ	r
β	b	κ, κ	c, k	σ, σ	s
γ	g	λ	l	τ	t
δ	d	μ	m	υ	y
ε	e	ν	n	φ	ph
ζ	z	ξ	x	χ	ch
η	e	ο	o	ψ	ps
θ	th	π	p	ω	o

#### II. LATIN AND GREEK DICTIONARIES

Recommended dictionaries are: Harper's *Latin dictionary* and Liddell and Scott's *A Greek-English lexicon*. For Greek proper names, not included in Liddell and Scott, Harper's *Dictionary of classical literature and antiquities* may be used. These are standard dictionaries available at all good libraries.

Special problems can be solved by consulting the following larger dictionaries: Forcellini: *Totius Latinitatis lexicon*; Estennes: *Thesaurus Graecae linguae*; De-Vit: *Totius Latinitatis onomasticon*.

#### III. USE OF LATIN DICTIONARIES

In the Latin dictionaries above mentioned, a substantive is represented by a word followed by the genitive ending and a gender notation: *m.* for masculine; *f.*, for feminine; and *n.*, for neuter. Ex.: *lupus, i, m.*

An adjective or a participle is represented by a word followed by:

1. Two gender endings and the notation *adj.* or *Part.* Ex.: *albus, a, um, adj.*; *expansus, a, um, Part.* These names have different forms for the three genders: *albus* and *expansus* for the masculine; *alba* and *expansa* for the feminine; *album* and *expansum* for the neuter.

2. A gender ending and the notation *adj.* Ex.: *habilis, e, adj.* These adjectives have the same form, *habilis*, for the masculine and feminine and another, *habile*, for the neuter.

3. The genitive ending and the notation *adj.* or *Part.* Ex.: *audax, acis, adj.*; *virens, entis, Part.* Such names have the same endings for all genders.

Words other than substantives, adjectives, or participles, are easily recognized by such notations as *pron.*, *adv.*, *prep.*, *conj.*, etc., or by their English meaning.

#### IV. USE OF THE GREEK DICTIONARIES

Greek, in contrast to Latin, has articles which are used in the dictionaries to indicate gender. These are: *ὁ* masculine; *ἡ* feminine; and *τό* neuter.

In the Greek dictionaries above mentioned, substantives are represented by a word followed by the article. Ex.: *ὄστρακον, τό*, which is consequently neuter.

An adjective is represented by a word followed by:

1. Two gender endings. Ex.: *δίκαιος, η, ου*. These adjectives have different forms for the three genders; *δίκαιος* m.; *δικαίη*, f.; *δίκαιον*, n.

2. One gender ending. Ex.: *ἀνάλογος, ου*; *εὐγενής, ἐς*. In such cases, the first forms, *ἀνάλογος, εὐγενής*, are either masculine or feminine, and the second ones, *ἀνάλογον, εὐγενές*, are neuter.

3. The genitive ending and two articles. Ex.: *ἄρπας, αγος, ὁ, ἡ; φαίνοψ, οπος, ὁ, ἡ*. Such names have the same ending for both masculine and feminine and no neuter form.

Words that are neither substantives nor adjectives, may be recognized by their English meaning.

#### LATINIZATION OF GREEK WORDS

Greek words are latinized by transliterating according to the equivalents noted above and in addition the following:

final η	a	final ος	us	γχ	neh	έ, ἡ	he
αι	e	final ου	um	γκ	nc	ι	hi
ει, η	i	ου	u	ρ	rh	δ, ω	ho
οι, φ	e	γγ	ng	α	ha	ύ	hy

Also it should be noted that Greek adjectives with the two endings -os, m. and f.; -on, n., have three forms in Latin: *ἀνάλογος, analogus*, m.; *ἀνάλογος, analoga*, f.; *ἀνάλογον, analogum*, n.; *βάρβαρος, barbarus*, m.; *βάρβαρος, barbara*, f.; *βάρβαρον, barbarum*, n.

#### DETERMINATION OF GENDER

Two examples will suffice to illustrate the process of determining the genders of names. Consider the generic names *Lepas* and *Cyphosoma*.

In the Latin dictionary *Lepas* is found as *Lepas, adis, f.*, and therefore this is a feminine substantive.

Compound words usually will not be found as such in the dictionaries. However, they will be easily recognized because their initial parts will be found as independent words. Once the compound character of the word has been recognized, only its latter part needs to be considered for the gender determination. Thus *Cyphosoma* is a compound word formed by *Cypho* and *soma*. The latter does not occur in the Latin dictionary. By transliteration into Greek this becomes *συμα* or *σωμα* (Latin *o* corresponds to the two Greek letters *ο* and *ω*). The latter appears in the Greek dictionary as *ὠμα, τό*. *Cyphosoma* is therefore a neuter substantive.

#### LIMITATIONS

Some possibilities of error or doubt remain:

1. Misspelled names and failure to recognize barbaric and artificial words as such may lead to wrong identifications in the dictionaries.

2. Declinable words in cases other than the nominative singular (*Amantis*) may not be found in the dictionaries.

3. The same word may be found to have different values and meanings. As suggested, names that may be either substantives or adjectives should be considered substantives, if used as generic names, or adjectives, if used as specific names. Other names may be either substantives or adverbs (*Parum*), pronouns or adverb (*Alia*), verbs or adverbs (*Parce*), etc. No rule can be set for these names, and each must be considered individually. They occur very rarely.

#### BIBLIOGRAPHY

- BAKER, H. B. *Gender in generic names*. Nautilus **43**: 139-40. 1929.
- BARTENSTEIN, H. *Do specific names of the Foraminifera accord with the rules of nomenclature?* Contr. Cushman Found. Foram. Res. **1**: 79-80. 1950.
- BLACKWELDER, R. E. *The gender of scientific names in zoology*. Journ. Washington Acad. Sci. **31**: 135-140. 1941.
- CASEY, T. L. *Coleopterological notes: Pt. 2*. Ann. New York Acad. Sci. **5**: 307-504. 1890.
- GUBA, E. F., AND LINDER, D. H. *Mycological nomenclature*. Mycologia **24**: 415-419. 1932.
- KIRIAKOFF, S. G. *Quelques remarques nomenclatoriales*. Bull. et Ann. Soc. Ent. Belgique **85**: 173-79. 1949.
- MACFADYEN, W. A., and KENNY, E. J. A. *On the correct writing in form and gender of the names of the Foraminifera*. Journ. Roy. Micr. Soc. (3) **54**: 177-81. 1934.



- McATEE, W. L. *Automatic nomenclature*. Proc. Ent. Soc. Washington **30**: 72-76. 1928.
- RICHTER, R. *Ist eine unveränderliche Form des Art-Namens möglich?* Senckenb. **25**: 340-356. 1942.
- . *Die "Berichtigung" von Namen nach Artikel IRZN, an den Fallen senckenbergii und smithae c/a smithi*. Senckenb. **31**: 269-72. 1950.
- ROBERTSON, C. *About nomenclature*. Amer. Nat. **67**: 53-61. 1933.
- SCHENK, E. T., AND McMASTERS, J. M. *Procedure in taxonomy*, rev. ed., 93 pp. Stanford, Calif., and London, 1948.

- STAINFORTH, R. M. *Nomenclatural notes on Puzosia and Cibicides*. Journ. Pal. **23**: 436-438. 1949.
- . *Comments to "A Pitfall of Paleontological 'Latin'."* Journ. Pal. **24**: 504-505. 1950.
- THALMANN, H. E. *"Foraminifera from the Tertiary of the Dominican Republic," by Pedro Joaquin Bermudez* (review). Bull. Amer. Assoc. Petr. Geol. **34**: 2227-2229. 1950.
- VAN BELLEN, R. C. *A pitfall of paleontological "Latin."* Journ. Pal. **24**: 504. 1950.
- WELLER, J. M. *Ist eine unveränderliche Form des Art-Namens möglich?* (review). Journ. Pal. **24**: 507-12. 1950.

ZOOLOGY.—*Adercotryma*, a new Recent foraminiferal genus from the Arctic.  
ALFRED R. LOEBLICH, JR., and HELEN TAPPAN, U. S. National Museum.

In a current restudy of the foraminiferal genotype species, the writers have encountered numerous species that do not agree with the generic descriptions or the genotype species of the genera to which they had been assigned. This is especially true of the Lituolidae. In his excellent work on the Foraminifera of the Gullmar Fjord and the Skagerak, Höglund (1947, p. 132) did much to clarify some of these problems and subdivided the genus *Haplophragmoides* Cushman. From *Haplophragmoides* sensu stricto he differentiated two genera, *Labrospira* Höglund and *Ammoscalaria* Höglund. However, the writers feel that one species which Höglund treated in this paper, *Haplophragmoides glomeratum* (Brady) is also sufficiently distinct to warrant separate generic status, based on differences in shell morphology and form and position of aperture. These features are considered to be of fundamental importance in the classification of the Foraminifera.

Family LITUOLIDAE

*Adercotryma* Loeblich and Tappan, n. gen.

Genotype (type species): *Lituola glomerata* Brady, 1878.

Test free, planispiral, subglobular or ovate, elongate in the direction of the axis of coiling, slightly asymmetrical; wall agglutinated; aperture may be lacking in the final chamber, or when present is interio-marginal, forming a low slit or arch near the umbilicus of one side, and closer to the umbilicus than to the periphery.

*Remarks.*—*Adercotryma* differs from *Haplophragmoides* Cushman, as based on the genotype

species, in being somewhat asymmetrical, in being completely involute, rather than slightly evolute, in having the greatest dimension in the axis of coiling, rather than in being somewhat compressed, and in the character of the aperture, which is found near the umbilicus of one side rather than in the plane of coiling at the periphery, or may even be completely lacking in the final chamber.

*Adercotryma glomeratum* (Brady)

Figs. 1-4

*Lituola glomerata* Brady, Ann. Mag. Nat. Hist., ser. 5, **1**: 433, pl. 20, figs. 1a-c. 1878.

*Haplophragmium glomeratum* (Brady) Goës, Kongl. Svenska Vet.-Akad. Handl. **25** (9): 23, pl. 5, figs. 134-139. 1894.

*Haplophragmoides glomeratum* (Brady) Cushman, U. S. Nat. Mus. Bull. **71** (1): 104, figs. 158-161. 1910; U. S. Nat. Mus. Bull. **104**, pt. 2: 47, pl. 9, fig. 6. 1920; Höglund, Zool. Bidrag Uppsala: 135, pl. 10, figs. 3-4, text fig. 112, 1947; Cushman, Cushman Lab. Forum. Res. Spec. Publ. **23**: 28, pl. 2, fig. 16. 1948.

Test free, subglobular to slightly ovate, planispiral but somewhat asymmetrical, with about two whorls present, greatest dimension in the axis of coiling, periphery broadly rounded; chambers few in number, only the four of the final whorl visible, very broad and low, slightly inflated, somewhat wedge-shaped with the narrower portion on the side with the aperture; sutures distinct, rather straight, slightly constricted; wall rather coarsely arenaceous, with considerable cement between the grains; aperture may be indistinct or lacking, or form a short slit or low arch at the inner margin of the final chamber, about one-half to two-thirds the distance from the periphery to the umbilicus, on the narrower side of the test.

*Remarks.*—Brady (1878, p. 433) in describing this species states, "Aperture at the inner margin of the terminal chamber, near the exterior of the corresponding segment of the previous convolution, simple, often obscure." Cushman (1948, p. 28) states that the aperture is "a short slit at the base of the chamber, often obscured by sand grains." It remained for Höglund (1947, p. 135, pl. 10, fig. 4) to clearly demonstrate the position of this aperture. He found the aperture to be "interio-marginal, forming a short slit at the margin of the last chamber, near the narrow end of the oviform test, most frequently indistinct or even lacking." In any large series of specimens, apertures are occasionally seen. These are of two types, either a low arch about halfway between the periphery and the umbilicus (Figs. 2, 3, 4b) or forming a slit that extends along the inner margin of the final chamber to the umbilicus (Fig. 1b). Höglund suggested that specimens lacking an aperture might be in a growth stage in which it had not yet been developed. It is possible that

different stages of growth may account for the two variations of apertures here mentioned.

*Types and occurrence.*—Figured hypotypes (USNM P. 829a-c) and unfigured hypotypes (USNM P. 830) from mud and sand bottom off the south end of Humboldt Glacier, northwest Greenland at a depth of 110 fathoms; collected by Capt. Robert A. Bartlett. Figured hypotype (USNM P. 831) and unfigured hypotypes (USNM P. 832) at a depth of 50 to 57 fathoms, off Clavering Island, northeast Greenland; collected by Capt. Robert A. Bartlett. This species has been widely recorded in both the Atlantic and Pacific Oceans.

#### REFERENCES

- BRADY, H. B. *On the reticularian and radiolarian Rhizopoda (Foraminifera and Polycystina) of the North-Polar Expedition of 1875-76.* Ann. Mag. Nat. Hist., ser. 5, 1: 425-440. 1878.
- CUSHMAN, J. A. *Arctic Foraminifera.* Cushman Lab. Foram. Res. Spec. Publ. 23: 1-79. 1948.
- HÖGLUND, H. *Foraminifera in the Gullmar Fjord and the Skagerak.* Zool. Bidrag Uppsala 26: 1-328. 1947.



FIGS. 1-4.—*Adercoctryma glomeratum* (Brady): 1a, Side view of hypotype (USNM P. 831) showing four chambers of final whorl, and aperture extending into the umbilical area; 1b, edge view of same showing test slightly elongated along axis of coiling, somewhat wedge-shaped chambers and slitlike aperture; 2, edge view of hypotype (USNM P. 829a) showing low archlike aperture; 3, edge view of hypotype (USNM p. 829b) showing short slitlike aperture; 4a, side view of hypotype (USNM P. 829c); 4b, edge view of same showing low arched aperture. Illustrations are shaded camera-lucida drawings by Sally D. Lee, scientific illustrator, Smithsonian Institution. All  $\times 150$ .

ZOOLOGY.—*Buccella*, a new genus of the rotalid *Foraminifera*. HAROLD V. ANDERSEN, Louisiana State University. (Communicated by Alfred R. Loeblich, Jr.)

In 1948–1950, while working with foraminiferal faunules from the mudlumps off the Passes of the Mississippi River, the need for a new genus of *Foraminifera* became apparent. The species selected as the genotype, and also designated the genotype in this paper, has recently been described by Phleger and Parker (1951) as *Eponides hannai*. The morphologic feature of *E. hannai* that makes the species untenable as an *Eponides*—the presence of multiple apertures on the ventral side of the test—constitutes the diagnostic morphologic feature of the new genus *Buccella* introduced in this paper.

Also characteristic of *E. hannai* is a coating of pustules on the ventral side of the test. This morphologic feature was the medium by which the following species and varieties of *Eponides* in the U. S. National Museum and Cushman Collections were brought into the present study:

*Eponides alabamensis* Cushman and McGlamery, 1938

*Eponides choctawensis* Cushman and McGlamery, 1938

*Eponides frigida* (Cushman), 1921 (1922)

*Eponides frigida* (Cushman), var. *calida* Cushman and Cole, 1930

*Eponides hannai* Phleger and Parker, 1951

*Eponides mansfieldi* Cushman, 1930

*Eponides mansfieldi* Cushman, var. *oregonensis* Cushman, Stewart and Stewart, 1947 (1948)

*Eponides peruviana* (d'Orbigny), Cushman and Kellett, 1929; Cushman, Stewart and Stewart 1930; and Cushman and Parker, 1931

*Eponides vicksburgensis* Cushman and Ellisor, 1931

When the types of the above species were studied, discrepancies were noted between the descriptions and illustrations and the actual specimens, and within suites of specimens bearing the same specific designation. As a result of these discrepancies, three new species of the genus *Buccella* (*depressa*, *inusitata*, and *parkerae*) are described, and five species of *Eponides* (*hannai*, *frigida*, *mansfieldi*, *mansfieldi* var. *oregonensis*, and *vicksburgensis*) are placed in the genus *Buccella*. Emended descriptions and new figures of the above species of "*Eponides*," with the exception of "*E.*" *mansfieldi* var.

*oregonensis*, are presented to record the morphologic features omitted in the original descriptions that justify the assignment of these species to the genus *Buccella*.

Also as a result of this study, "*Eponides*" *frigida* (Cushman) is eliminated as a typical species of *Eponides* as suggested by Hofker (1950).

*Acknowledgments*.—The preparation of this paper was facilitated by the following people whose assistance and contributions are gratefully acknowledged: Dr. G. Arthur Cooper and Dr. Alfred R. Loeblich, Jr., U. S. National Museum, who placed the National Museum samples and equipment at the writer's disposal and aided in the preparation of this report; Miss Ruth Todd, U. S. Geological Survey, who reviewed the manuscript and supplied the samples from which the new species were described; Mrs. Sally Lee, who did such a commendable job in the preparation of the illustrations; and my wife, Dorothy S. Andersen, who assisted in the final preparation of the manuscript.

#### FAMILY ROTALIIDAE

#### *Buccella* Andersen, new genus

Genotype: *Eponides hannai* Phleger and Parker.

Test free, calcareous perforate, multilocular with chambers arranged in a trochoid coil; bi-convex. Dorsal side with all chambers and sutures visible; ventral side with sutures, umbilicus, and basal margin of adult chamber concealed wholly or in part with a coating of pustulose material. The primary aperture, interiomarginally situated about midway between the umbilicus and periphery on the ventral and anterior side of the last-formed chamber, is visible only from the interior of the chamber on well-preserved specimens. Single or multiple supplementary apertures, visible in some species, are developed at the postero-sutural margin of each chamber on the ventral side of the test and are typically situated in the distal portion of the chamber near the periphery.

*Remarks*.—The most obvious feature of the genus *Buccella* is the development of pustules on the ventral side of the test, which conceals the sutures, umbilicus, and basal, anterior margin

of the adult chamber. The diagnostic feature of *Buccella* is its supplementary apertures that are visible in a few species, but concealed in most. Weathering usually reveals the position and shape of the supplementary apertures in those species in which well-preserved specimens bear a thick coating of pustules along the ventral sutures.

*Buccella* can be differentiated from *Eponides* on the basis of the pustulose coating and supplementary apertures on the ventral side of the test, and from *Pseudoeponides* by the absence of elongate slits on the dorsal side of the chambers. *Eponides* has a single, simple and visible aperture at the base of the last formed chamber between the closed umbilicus and the periphery on the ventral side of the test. *Pseudoeponides* has a small, crescentic opening at the ventral border of the last chamber; loop-shaped openings along the ventral sutures radiating from the umbilicus; and elongate slits on the dorsal side at the middle part of the inner margin of each chamber.

*Range*.—Oligocene to Recent.

***Buccella hannai*** (Phleger and Parker)

Figs. 3a-c

*Eponides hannai* Phleger and Parker, Geol. Soc. Amer. Mem. 46: 21, pl. 10, figs. 11-14, 1951.

*Emended diagnosis*.—Test small; trochoid; biconvex, ranging from specimens with equal convexity on dorsal and ventral sides to specimens that are extremely convex on the dorsal side and nearly flat on the ventral side. Dorsal side with surface smooth, finely perforate and hyaline (in well-preserved specimens); and with curved and limbate sutures that form the peripheral margin of each chamber. Ventral side with surface more coarsely perforate than the dorsal surface; sutures depressed and radial; chambers slightly inflated; and with umbilicus, sutures, and anterior basal margin of last-formed chamber bearing a coating of pustulose material. Periphery distinctly lobulate; typically acute and limbate although an occasional specimen (not necessarily all young specimens) has a very rounded periphery. The number of chambers in the last-formed whorl range from 7 to 9, the most common being 8. Adult tests have 3 to 3½ coils.

The only visible apertures are the supplementary apertures on the ventral side of the test. Each aperture is a low arched opening located at the posterosutural margin of each

chamber. In those specimens with an acute periphery, the supplementary apertures are in a slight depression at the outer margin of the suture near the periphery. In those specimens with a rounded periphery, the apertures are located about midway between the periphery and the umbilicus.

When viewed from the interior, the adult chamber has an irregular-shaped primary aperture at the base and inner margin of the anterior wall; a septal foramen irregularly elliptical in outline and typically areal in the posterior wall that connects chambers in the same coil; and, in those forms examined, a round, septal foramen dorsally situated that connects adjacent chambers in previous coils.

Dimensions of figured specimen: Maximum diameter 0.38 mm.; maximum thickness 0.19 mm.

*Remarks*.—The typical form of *Buccella hannai* is easily distinguished from all other Recent species. It can be differentiated from *B. inusitata* by its smaller test and single posterosutural aperture in each chamber; from *B. frigida* by its less inflated test and visible supplementary apertures; and from *B. depressa* by its acute periphery, convex umbilicus, and visible supplementary apertures. The Oligocene form *B. vicksburgensis*, which might conceivably be the ancestor of *B. hannai*, has a less distinctly lobulate periphery and lacks the visible supplementary apertures of *B. hannai*.

*Types and occurrence*.—Reported from depths less than 100 meters in the northwest Gulf of Mexico (Phleger and Parker, 1951). Holotype (U.S.N.M. no. P. 835) and paratypes (U.S.N.M. nos. P. 836 and P. 838) from station 374 (lat. 28°24' N., long. 94°42.5' W.) at 35 meters water depth. Paratype (U.S.N.M. no. P. 837) from station 288 (lat. 26°30.5' N., long. 96°33' W.) at 59 meters water depth.

Also recovered from a mudlump island (L.S.U. Geology Museum Sample no. M-144) off South Pass of the Mississippi River, Louisiana (H. V. Howe Collection no. 4435).

***Buccella frigida*** (Cushman)

Figs. 4a-c, 5, 6a-c

*Pulvinulina frigida* Cushman, Contr. Can. Biol. 1921: 12, 1922.

*Eponides frigida* (Cushman), Cushman, U. S. Nat. Mus. Bull. 104, pt. 8: 45 (in part). 1931.

*Eponides frigidus* (Cushman), Cushman, Contr. Cushman Lab. Foram. Res. 17: 37, pl. 9, figs. 16, 17, 1941.

*Eponides frigida* (Cushman), var. *calida* Cushman and Cole, Contr. Cushman Lab. Foram. Res. 6 (4): 98, pl. 13, figs. 13a-c. 1930; Cushman, U. S. Nat. Mus., Bull. 104, pt. 8: 47. 1931; Cushman, Cushman Lab. Foram. Res. Special Publ. 12: 34, pl. 4, figs. 19, 20. 1944.

*Emended diagnosis.*—Test small; trochoid; biconvex. Dorsal side with smooth surface; and with narrow, slightly curved and limbate sutures oriented oblique to the peripheral margin. Ventral side with surface smooth and finely perforate; sutures slightly depressed, curved to radial, and filled with opaque pustulose material; chambers slightly inflated; and with umbilicus and basal margin of last-formed chamber bearing a thick coating of pustules. Periphery slightly lobulate, and broadly rounded. The number of chambers in the last-formed whorl range from 5 to 7, the most common being 6. Adult tests have  $2\frac{1}{2}$  to 3 coils.

In well-preserved specimens, all apertures are concealed by pustulose material. Weathered specimens exhibit, as shown in Fig. 5, an arched primary aperture at the basal margin of the final chamber about midway between the umbilicus and periphery, and low arched supplementary apertures located in slight depressions at the outer margin of the sutures near the periphery.

When viewed from the interior, narrow septal foramen, typically areal, connect chambers in the same coil.

Dimensions of figured specimens: lectotype (Figs. 6a-c), maximum diameter 0.46 mm., maximum thickness 0.20 mm.; hypotype (Figs. 4a-c), maximum diameter 0.46 mm., maximum thickness 0.22 mm.; and hypotype (Fig. 5), maximum diameter 0.40 mm., maximum thickness 0.20 mm.

*Remarks.*—The redefinition of *Buccella frigida* (Cushman) resulting from this study can be attributed to two factors: (1) That none of the original specimens identified as *Pulvinulina frigida* Cushman (1921) has been figured; and (2) that the literature has never clearly demonstrated the difference between *Eponides frigidus* (Cushman) and *E. frigida* (Cushman), Var. *calida* Cushman and Cole.

Subsequent to 1931, Cushman designated three cotypes of "*E.*" *frigidus* (Cushman Collection nos. 3031 (two specimens) and 3032 (one specimen)). On the basis of these cotypes, "*E.*" *frigida* (Cushman), var. *calida* Cushman and Cole has to be placed in synonymy with "*E.*"

*frigidus*. This observation is insured in this paper by refiguring the holotype of "*E.*" *frigida*, var. *calida* (Fig. 4), and by figuring for the first time in any publication one of the cotypes (herein designated the lectotype) of "*E.*" *frigidus* (Fig. 6).

*Buccella frigida* (Cushman) is an extremely variable species. The typical form is relatively small and robust, with a broadly rounded periphery, six to seven chambers in each whorl, and ventral sutures that are slightly curved. This form commonly occurs in samples from Hudson Bay and along the Atlantic coast as far south as Maryland. The Pacific coast forms are generally larger and have straighter sutures, but have the same number of chambers and the thick pustulose coating in the umbilicus. Despite these differences, it appears to be inadvisable to separate the two forms at this time since both forms may occur in the same sample along with transitional forms.

*B. frigida* more closely resembles *B. depressa* than any other Recent or late Tertiary species. It differs from *B. depressa* by its thicker coating of pustulose material which completely fills the umbilicus and sutures, by the fewer number of chambers in each whorl, by the smaller size of the test, and by the limbate chambers on the dorsal side of the test.

*Types and occurrence.*—Lectotype (Cushman Collection no. 3032) from station 5, bay between Black Whale and Olaks Harbors, east coast of Hudson Bay (about lat.  $55^{\circ}$  N.) at 10 fathoms water depth. Hypotype (of "*E.*" *frigida* (Cushman), var. *calida* Cushman and Cole (Cushman Collection no. 14213)), from the Pleistocene, Talbot formation, Wailes Bluff, near Cornfield Harbor, St. Marys County, Md. Hypotype (Cushman Collection no. 64505), off Pocasset, upper end of Buzzard Bay, Mass.

***Buccella depressa* Andersen, n. sp.**

Figs. 7a-c, 8

*Eponides peruvianus* Cushman and Parker (not d'Orbigny), Proc. U. S. Nat. Mus. 80 (art. 3): 19 (not figured). 1931.

Test of medium size; trochoid; dorsal and ventral sides equally biconvex. Dorsal side with surface smooth, finely perforate and hyaline (in well-preserved specimens); and with slightly curved sutures oriented oblique to the peripheral margin. Ventral side with surface more coarsely perforate than the dorsal surface; sutures greatly

depressed, nearly radial, and partly filled with opaque pustulose material; chambers inflated; and with depressed umbilicus and basal margin of last-formed chambers bearing a moderate coating of pustulose material. Periphery broadly acute to rounded and lobulate. The number of chambers in the last formed whorl ranges from 7 to 9, the most common being 8. Adult tests have  $2\frac{1}{2}$  to 3 coils.

In well-preserved specimens all apertures are concealed by pustulose material. Weathered specimens exhibit, as shown in Fig. 8, a low arched primary aperture at the basal margin of the last-formed chamber and slitlike supplementary apertures that extend along the outer postero-sutural margins of each chamber.

When viewed from the interior of the test, a narrow septal foramen intermarginally situated connects chambers in the same whorl. A single round septal foramen more or less centrally located in the dorsal side of the chamber connects adjacent chambers of previous coils.

Dimensions of figured specimens: Holotype, maximum diameter 0.46 mm, maximum thickness 0.20 mm; paratype, maximum diameter 0.49 mm, maximum thickness 0.22 mm.

*Remarks.*—Pacific coast specimens with pustulose material on the ventral side of the test, which were not identified as "*Eponides*" *frigida* or its variety *calida*, have been indiscriminately grouped under *Eponides peruviana* (d'Orbigny) [Cushman and Kellett (1929), Cushman, Stewart, and Stewart (1930), Cushman and Valentine

(1930), and Cushman and Parker (1931a)]. The Cushman and Kellett specimen has been placed in synonymy with *V. inusitata*; the Cushman, Stewart, and Stewart specimen is too badly weathered to be properly identified; the Cushman and Valentine specimen is neither *Eponides* nor *Buccella*; and the Cushman and Parker assemblage is the basis of this species *B. depressa*. The designation of the Cushman and Parker specimens as a new species is deemed advisable rather than to perpetuate an assumption that *Rotalia peruviana* d'Orbigny has a pustulose coating on the ventral side of the test.

In general appearance, *B. depressa* resembles the larger specimens of *B. frigida*. Differentiation between the two is based on the number of chambers, appearance of sutures, and intensity of the pustulose coating. *B. depressa* has more chambers in each whorl, much more depressed sutures and umbilicus, less pustulose material deposited in the sutures and umbilicus, and less limbate sutures on dorsal side than *B. frigida*. Other Recent species, *B. hannai*, and *B. inusitata*, can be distinguished from *B. depressa* by their acute peripheries.

*Types and occurrence.*—Holotype (U.S.N.M. no. P. 833) and paratype (U.S.N.M. no. P. 834) from station 97, Port Williams, Falklands, at 8 to 10 fathoms. Unfigured paratypes (Cushman Collection no. 21256) from same locality as above and unfigured paratypes (Cushman Collection no. 21257) from station 87, off lower jetty, Port Howard, Falklands, at 4 fathoms.

FIG. 1, 2.—*Buccella vicksburgensis* (Cushman and Ellisor): 1a, Dorsal view of holotype (Cushman Coll. no. 15521); 1b, ventral view; and 1c, edge view (note: opening is fracture not aperture); 2a, dorsal view of hypotype (holotype of *Eponides alabamensis* Cushman and McGlamery, Cushman Coll. no. 23678); 2b, ventral view; 2c, edge view. Oligocene and L. Miocene?.

FIG. 3.—*Buccella hannai* (Phleger and Parker): 3a, Dorsal view of holotype (U.S.N.M. no. P. 835); 3b, ventral view showing supplementary apertures at outer margin of suture; 3c, edge view. Recent, Gulf of Mexico.

FIGS. 4-6.—*Buccella frigida* (Cushman): 4a, Dorsal view of hypotype (holotype of *Eponides frigida* (Cushman), var. *calida* Cushman and Cole, Cushman Coll. no. 14213); 4b, ventral view; and 4c, edge view; 5, ventral view of weathered hypotype (Cushman Coll. no. 64505) showing position of supplementary apertures normally concealed by pustules; 6a, dorsal view of lectotype (Cushman Coll. no. 3032); 6b, ventral view; 6c, edge view. Late Tertiary to Recent.

FIGS. 7, 8.—*Buccella depressa* Andersen, n. sp.: 7a, Dorsal view of holotype (U.S.N.M. no. P. 833); 7b, ventral view; 7c, edge view; 8, ventral view of weathered paratype (U.S.N.M. no. P. 834) showing position of supplementary apertures normally concealed by pustules. Recent.

FIG. 9.—*Buccella parkerae* Andersen, n. sp.: 9a, Dorsal view of holotype (Cushman Coll. no. 14582); 9b, ventral view; 9c, edge view. Miocene.

FIGS. 10, 11.—*Buccella inusitata* Andersen, n. sp.: 10a, Dorsal view of holotype (Cushman Coll. no. 64503); 10b, ventral view; 10c, edge view; 11a, dorsal view of paratype (Cushman Coll. no. 64504); 11b, ventral view; 11c, edge view. Recent.

FIGS. 12, 13.—*Buccella mansfieldi* (Cushman): 12a, Dorsal view of hypotype (Cushman Coll. no. 46507); 12b, ventral view; 12c, edge view; 13a, dorsal view of hypotype (Cushman Coll. no. 46506); 13b, ventral view; 13c, edge view. Miocene.

All magnifications  $\times 50$ .

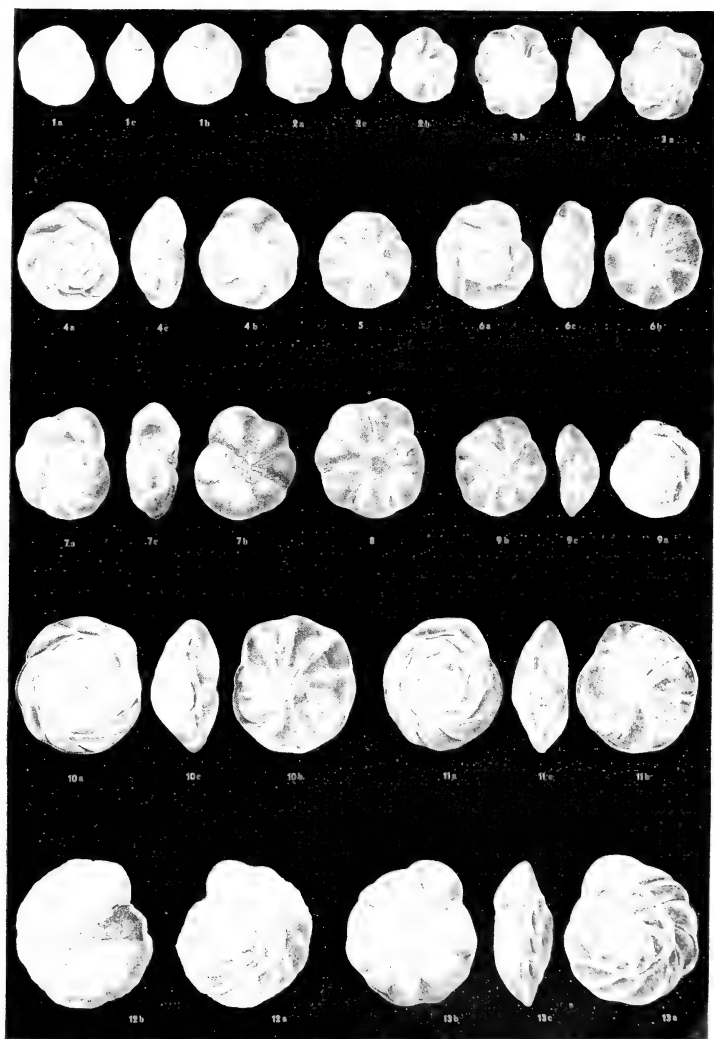

FIGS. 1-13.—(See opposite page for legend)

***Buccella inusitata*** Andersen, n. sp.

Figs. 10a-c and 11a-c

*Eponides frigidus* (Cushman), Cushman and Todd, Cushman Lab. Foram. Res. Special Publ. 21: 21 (Cushman Collection no. 48597 not figured). 1947.

*Eponides peruvianus* Cushman and Kellett (not d'Orbigny), Proc. U. S. Nat. Mus. 75 (art. 25): 10, pl. 4, figs. 5a-c. 1929.

*Eponides frigidus* (Cushman), Cushman, Cushman Lab. Foram. Res. Special Publ. 23: 71, pl. 8, fig. 7. 1938.

Test of medium size; trochoid; dorsal and ventral sides equally biconvex in the microspheric form; megalospheric generation with the ventral side nearly flat and dorsal side extremely convex. Dorsal side with surface smooth, finely perforate and hyaline; and with slightly limbate sutures oriented strongly oblique to the peripheral margin and confluent with the periphery. Ventral side with surface rough and more coarsely perforate than the dorsal side; sutures depressed and radial; chambers slightly inflated, and with umbilicus, sutures, and basal margin of the last-formed chamber bearing a thick coating of pustulose material. Periphery acute and limbate, and with the last 2 or 3 chambers usually lobate. The number of chambers in the last-formed whorl ranges from 7 to 9, the most common being 9. Adult tests have 3 to 3½ coils.

The only visible apertures are located on the ventral side of the test at the outer margin of each suture. In a slight depression near the periphery is a concentration of pustulose material through which are numerous, irregularly shaped openings. These openings emanate from the posterosutural margin of the younger (most recently added) chamber and from the anterosutural margin of the older (preceding) chamber.

The last-formed chamber when viewed from the interior has no well defined anterior aperture. Preceding chambers, however, have a well developed, narrow septal foramen intermarginally situated and numerous areal cribrate openings near the periphery which connect chambers in the same coil. One or two lateral foramen connect adjacent chambers of previous coils.

Dimensions of figured specimens: Holotype, maximum diameter 0.57 mm, maximum thickness 0.27 mm; paratype, maximum diameter 0.55 mm, maximum thickness 0.24 mm.

*Remarks.*—*Buccella inusitata* is characterized by its large test, by its acute and limbate periph-

ery, by its limbate dorsal sutures, and by its supplementary apertures consisting of numerous irregularly shaped openings. It can be distinguished from *B. frigida* and *B. depressa* by its greater size and acute periphery; from *B. hannai* by its greater size and multiple openings in the outer portion of the ventral sutures; and from *B. mansfieldi* by its smaller size, lack of raised and limbate dorsal sutures, and greater development of pustulose material along the sutures. *B. inusitata* most closely resembles *B. oregonensis* from which it differs in having more inflated chambers on the ventral side of the test; less convexity in the umbilicus; and multiple supplementary apertures.

*Types and occurrence.*—Holotype (Cushman Collection no. 64503) and paratype (Cushman Collection no. 64504) from Dallas Bank, Straits of Juan de Fuca, station "A," coast of Washington. Unfigured paratypes (Cushman Collection no. 48597) from same locality as holotype. Station "A" refers to the list of stations in Special Publication 21 (Cushman and Todd, 1947).

***Buccella mansfieldi*** (Cushman)

Figs. 12a, b and 13a-c

*Eponides mansfieldi* Cushman, Florida Geol. Surv. Bull. 4: 54, pl. 11, figs. 1a-c. 1930.

*Emended diagnosis.*—Test large for the genus; trochoid; biconvex, ranging from specimens with equal convexity on dorsal and ventral sides to specimens less convex on the ventral side. Dorsal side with surface finely perforate and hyaline (in well-preserved specimens); and with broadly limbate and raised sutures oriented oblique to the peripheral margin and confluent with the periphery. Ventral side with surface rough and more coarsely perforate than the dorsal side; sutures depressed and radial; chambers slightly inflated; and with the depressed umbilicus, sutures, and anterior, basal margin of the last-formed chamber bearing a coating of pustulose material (a few specimens have pustules covering the entire ventral side of the test). Periphery acute, broadly limbate, and lobulate. The number of chambers in the last whorl range from 9 to 12, the most common being 11. Adult test with 2½ to 3 coils.

All apertures are concealed by pustulose material. When viewed from the interior, the adult chamber has an irregularly shaped opening at the



base and inner margin of the anterior wall, and a long, narrow slitlike opening at the base and outer margin of the posterior wall. This slitlike opening which, externally, would lie at the posterior sutural margin of the chamber, is so minute that it can not be discerned even in weathered specimens.

Comma-shaped, internal septal foramen connect adjacent chambers in the same coil; none appear to connect chamber in previous coils.

Dimensions of figured specimens: Hypotype (Fig. 12), maximum diameter 0.62 mm, maximum thickness 0.28 mm; hypotype (Fig. 13), maximum diameter 0.62 mm, maximum thickness 0.25 mm.

*Remarks.*—*Buccella mansfieldi* is larger, has a greater number of chambers, and has a more ornamented dorsal surface than any other species. It lacks the open supplementary apertures of *B. hannai* and *B. inusitata*. Even weathered specimens fail to exhibit supplementary apertures in the striking manner of some specimens of *B. frigida*, *B. depressa*, and *B. vicksburgensis*. The most evident characteristic of the genus *Buccella* exhibited by *B. mansfieldi* is the pustulose material coating the ventral side of the test.

*Types and occurrence.*—Hypotype, Fig. 12 (Cushman Collection no. 46507), is from the Choctawhatchee marl of John Anderson's farm,  $\frac{1}{4}$  mile east of Red Bay, Walton County, Fla. It is from the same locality as the holotype (U.S.N.M. no. 371079), although it was not designated a paratype by Cushman. Hypotype, Fig. 13 (Cushman Collection no. 64506), is from the Miocene Choctawhatchee formation, Yoldia zone, Old Frazier farm,  $\frac{1}{4}$  mile south of center of section 18, T. 2 N., R 19 W., Walton County, Fla.

***Buccella oregonensis*** (Cushman, R. E. Stewart, and K. C. Stewart)

*Eponides mansfieldi* Cushman, var. *oregonensis* Cushman, Stewart, and Stewart, Oregon Dept. Geol. and Min., Ind. Bull. 36, (2): 43, pl. 6, fig. 4. 1947(1948).

*Remarks.*—The holotype of *B. oregonensis* (Cushman, Stewart, and Stewart) is the only representative of the species in the Cushman Collection. This constitutes an inadequate number of specimens upon which to base a study, and in this species it is particularly inadvisable since the final chamber of the holotype is broken. There is sufficient evidence, however, that the

species belongs with the genus *Buccella*, and that there is no justification in continuing to consider it a variety of *B. mansfieldi*. *B. oregonensis* has neither the size nor dorsal ornamentation of *B. mansfieldi*. The species most similar to *B. oregonensis* is *B. inusitata*. Differentiation between the two is based on the more inflated chambers on the ventral side of the test, the less convex umbilicus and the multiple supplementary apertures of *B. inusitata*.

*Types and occurrence.*—Holotype (Cushman Collection no. 44208) from the Miocene shale of the Astoria formation, 700 feet southeast of Yaquina Head, Yaquina quadrangle, Oregon.

***Buccella parkerae*** Andersen, n. sp.

Figs. 9a-c

*Eponides mansfieldi* Cushman, Cushman and Parker (not Cushman, 1930), Contr. Cushman Lab. Foram. Res. 7 (1): pl. 2, fig. 10a-c. 1931.

Test small; trochoid; biconvex, dorsal side nearly conoidal, ventral side with an umbilical flattening. Dorsal side with surface coarsely perforate; and with sutures of variable intensity; in the early coils concealed by a thin exogenous covering of shell material, in the last coil distinct, limbate, and in some specimens slightly raised above the surface of the test. Ventral side with surface coarsely perforate; depressed sutures radial near the umbilicus and abruptly curved backward at the peripheral margin; umbilicus depressed; and with umbilicus, sutures, and basal margin of the last-formed chamber bearing a coating of pustulose material, thickly deposited in the umbilicus, less densely deposited in the outer portion of the sutures. Periphery acute, limbate and slightly lobulate. The number of chambers in the last-formed whorl range from 9 to 11, 11 being the most common. Adult tests with  $2\frac{1}{2}$  to 3 coils.

The primary aperture is concealed by pustules. Supplementary apertures on the ventral side of the test are located in the slight depression at the outer margin of the suture near the periphery. Each aperture is a long, slitlike opening barely visible under high magnification.

When viewed from the interior, comma-shaped septal foramen connect chambers in the same coil.

Dimensions of figured holotype: maximum diameter 0.42 mm; maximum thickness 0.17 mm.

*Remarks.*—*Buccella parkerae*, originally identified as *Eponides mansfieldi* by Cushman and

Parker (1931b), has a superficial resemblance to the Florida species. It differs from *B. mansfieldi*, however, in its smaller size and less intensely ornamented dorsal surface. In *B. mansfieldi* the raised sutures on the dorsal side of the test are clearly defined from the proloculus to the periphery. In *B. parkerae* the proloculus and early coils of the dorsal spire are concealed by a thin coating of exogenous material that produces a low, conoidal capping in the center of the test. Only the last-formed coil or coil and half has distinct sutures with the barest indication being raised above the surface of the test.

*Buccella parkerae* can be distinguished from all other Pacific coast forms by the exogenous material on the dorsal side of the test. In addition, *B. parkerae* differs from *B. inusitata* by its raised dorsal sutures, smaller size, and more curved ventral sutures; from *B. depressa* by its acute periphery, limbate and raised dorsal sutures, and less depressed umbilicus; and from *B. oregonensis* by its smaller size, and depressed umbilicus.

*Types and occurrence.*—Holotype (Cushman Collection no. 14582), and unfigured paratypes (Cushman Collection no. 14583), from the Miocene, upper Tremblor formation, 1,500 feet west and 1,000 feet south of northeast corner of section 3, T. 28 S., R. 28 E., M.D.B.M., east side of San Joaquin Valley, Calif.

***Buccella vicksburgensis*** (Cushman and Ellisor)

Figs. 1a-c, 2a-c

*Eponides vicksburgensis* Cushman and Ellisor, Contr. Cushman Lab. Foram. Res. 7 (3): 56, pl. 7, figs. 8a-c. 1931.

*Eponides alabamensis* Cushman and McGlamery, U. S. Geol. Surv. Prof. Paper 189-D: 110, pl. 27, fig. 2. 1938.

*Eponides choctawensis* Cushman and McGlamery, U. S. Geol. Surv. Prof. Paper 189-D: 110, pl. 27, fig. 1. 1938.

*Emended diagnosis.*—Test small, trochoid; bi-convex, megalospheric forms with dorsal side strongly convex, microspheric forms with ventral side slightly flattened. Dorsal side with surface smooth, finely perforate and hyaline (in well-preserved specimens); and with limbate sutures oriented oblique to the peripheral margin and confluent with the limbate periphery. Ventral side with surface rough and more coarsely perforate than the dorsal side; sutures slightly depressed and slightly curved; and with chambers slightly inflated. Typical specimens have pustu-

lose only on the sutures, umbilicus, and anterior basal margin of the last-formed chamber. Megalospheric forms have a slightly rounded periphery; microspheric forms have an acute, limbate and slightly lobulate periphery. The number of chambers in the last whorl range from 6 to 8, the most common being 7. Adult tests with 2½ coils.

All apertures are concealed by pustulose material. An occasional weathered specimen reveals the posterosutural apertures in slight depressions near the peripheral margin on the ventral side of the test. When viewed from the interior, the final chamber has an irregularly shaped opening at the base and inner margin of the anterior wall and a small arched opening at the base and outer margin of the posterior wall.

Also from the interior, comma-shaped septal foramen connect adjacent chambers in the same coil; and rounded septal foramen, laterally situated in each chamber connect adjacent chambers in previous coils.

Dimensions of figured specimens: Holotype, maximum diameter 0.33 mm, maximum thickness 0.20 mm. Hypotype (holotype for "*E. alabamensis*") maximum diameter 0.32 mm, maximum thickness 0.17 mm.

*Remarks.*—The factors which have a bearing on the placement of "*Eponides alabamensis*" and "*E. choctawensis*" in synonymy with *B. vicksburgensis* are: (1) Morphologic homogeneity noted in the actual specimens not discernible from the original descriptions and illustrations; and (2) the number of specimens of a species reported in the literature.

"*E. vicksburgensis*" and "*E. alabamensis*" were found to be incorrectly described and illustrated. In "*E. vicksburgensis*", the opening at the base is a void produced by breakage not an aperture prepared by the animal; and the sutures on the ventral side of the test are more concealed by pustules than illustrated. In "*E. alabamensis*" the aperture is concealed by pustules, not open as illustrated and described; there are no costae across the sutures on the ventral side of the test as illustrated and described in the text; and the sutures on the ventral side of the test are more nearly concealed with pustules than illustrated. When purged of inaccuracies, the descriptions reflect the morphologic similarity apparent in the actual specimens. Additive proof of this morphologic similarity lies in an assemblage of specimens identified as *Eponides alabamensis* (Cushman Collection no. 25950) from the Chickasawhay marl near Millry, Ala. This assemblage

contains specimens with the thick coating of pustules on the ventral side of the test similar to the holotype of "*E. vicksburgensis*," and also specimens with the reduced pustulose coating on the ventral side of the test that characterizes the holotype of "*E. alabamensis*."

"*Eponides choctawensis*" has been reported three different times: Cushman and McGlamery, 1938; Cushman and McGlamery, 1942; and Cushman and Todd, 1946. In the last two reports the presence of the species in the sample is based on a single specimen. It is even possible that the holotype is based on a single specimen since there are no paratypes in the Cushman Collection. In addition to the limited number of specimens available of "*E. choctawensis*," it is also significant to note that "*E. choctawensis*" has been reported only from samples in which "*E. alabamensis*" (*B. vicksburgensis*) is also present and well represented by a number of specimens. The conclusion drawn is that "*E. choctawensis*" probably represents a variant or phase in the life cycle of *B. vicksburgensis* and therefore does not warrant a separate specific name. An analogy can be drawn with *B. hannai* in which a small, rare form with more inflated chambers and a more lobulate and rounded periphery than the typical form is accepted in the species (Phleger and Parker, 1951).

The typical specimen of *B. vicksburgensis* is easily distinguished from any other species of *Buccella* by its thick pustulose coating on the ventral side of the test. In comparison with other Atlantic and Gulf Coast forms and in addition to the above characteristic, it can be differentiated from *B. mansfieldi* by its smaller size, and lack of ornamentation of the dorsal sutures; from *B. frigida* by its acute periphery; and from *B. hannai* by its lack of open supplementary apertures, and less lobate periphery.

## REFERENCES

- ASANO, KIYOSHI. *Illustrated catalogue of Japanese Tertiary smaller Foraminifera, Part 14: Rotaliidae*. Institute of Geology and Paleontology, Tohoku University, Japan, 1951.
- BROTZEN, FRITZ. *Foraminiferengattung Gravelinella* *Nov. Gen. und die Systematik Rotaliiformes*, *Sver. Geol. Unders.*, Sec. C, no. 451. 1942.
- CUSHMAN, J. A. *Results of the Hudson Bay Expedition 1920. I, The Foraminifera*. *Contr. Can. Biol.* 1920. 1922.
- . *The Foraminifera of the Choctawhatchee Formation of Florida*. *Florida State Geol. Surv. Bull.* 4. 1930.
- . *The Foraminifera of the Atlantic Ocean. Part 8. Rotaliidae, Amphisteginidae, Calcarinidae, Cymbaloporettidae, Globorotaliidae, Anomalinidae, Planorbulinidae, Rupertiidae, and Homotremidae*. *U. S. Nat. Mus. Bull.* 104, pt. 8. 1931.
- . *Some fossil Foraminifera from Alaska*. *Contr. Cushman Lab. Foram. Res.* 17, pt. 2. 1941.
- . *Foraminifera from the shallow water of the New England coast*. *Cushman Lab. Foram. Res. Special Publ.* 12. 1944.
- . *Arctic Foraminifera*. *Cushman Lab. Foram. Res. Special Publ.* 23. 1948.
- CUSHMAN, J. A., and COLE, W. S. *Pleistocene Foraminifera from Maryland*. *Contr. Cushman Lab. Foram. Res.* 6, pt. 4. 1930.
- CUSHMAN, J. A., and ELLISOR, A. C. *Some new Tertiary Foraminifera from Texas*. *Contr. Cushman Lab. Foram. Res.* 7, pt. 3. 1931.
- CUSHMAN, J. A., and KELLETT, B. *Recent Foraminifera from the west coast of South America*. *Proc. U. S. Nat. Mus.* 75, art. 25. 1929.
- CUSHMAN, J. A., and MCGLAMERY, W. *Oligocene Foraminifera near Milry, Alabama*. *U. S. Geol. Surv. Prof. Paper* 197-B. 1942.
- CUSHMAN, J. A., and PARKER, F. L. *Recent Foraminifera from the Atlantic coast of South America*. *Proc. U. S. Nat. Mus.* 80, art. 3. 1931a.
- . *Miocene Foraminifera from the Temblor of the east side of the San Joaquin Valley, California*. *Contr. Cushman Lab. Foram. Res.* 7, pt. 1. 1931b.
- CUSHMAN, J. A., STEWART, R. E., and STEWART, K. C. *Tertiary Foraminifera from Humboldt County, California. A preliminary survey of the fauna*. *Trans. San Diego Soc. Nat. Hist.* 6, pt. 2. 1930.
- . *Astoria Miocene Foraminifera from Agate Beach, Lincoln County, Oregon*. *Oregon Dept. Geol. and Min. Ind. Bull.* 36, pt. 2. 1947.
- CUSHMAN, J. A., and TODD, R. *A foraminiferal fauna from the Byram Marl at its type locality*. *Contr. Cushman Lab. Foram. Res.* 22, pt. 3. 1946.
- . *Foraminifera from the coast of Washington*. *Cushman Lab. Foram. Res. Special Publ.* 21. 1947.
- CUSHMAN, J. A., and VALENTINE, W. W. *Shallow-water Foraminifera from the Channel Islands of southern California*. *Contr. Dept. Geol. Stanford Univ.* 1, no. 1. 1930.
- HOFKER, J. *What is the genus Eponides?* *Micro-paleontologist* 4 (1). 1950.
- . *The Foraminifera of the Siboga Expedition, Part III*. *Monographie IVa de: Uitkomsten op Zoologisch, Botanisch, Oceanographisch en Geologisch Gegend. Leiden*. 1951.
- D'ORBIGNY, A. D. *Voyage dans l'Amérique Méridionale* 5, pt. 2. 1839.
- PHLEGER, F. B., and PARKER, F. L. *Ecology of Foraminifera, northwest Gulf of Mexico*. *Geol. Soc. Amer. Mem.* 46. 1951.

MAMMALOGY.—A new pine mouse (*Pitymys pinetorum carbonarius*) from the southern Appalachian Mountains.<sup>1</sup> CHARLES O. HANDLEY, JR., U. S. National Museum. (Communicated by H. W. Setzer.)

As long ago as 1900 Vernon Bailey noticed that the pine mouse (*Pitymys pinetorum*) of the Cumberland Plateau region of the southeastern United States differed in important respects from other populations farther to the south and southwest. In his *Revision of American voles of the genus Microtus*, North American Fauna no. 17: 65. 1900, he remarked that: "A series of 31 specimens in the Merriam collection from Eubank, Ky., average darker and richer in coloration than the type series [referring to *P. p. auricularis*], and have equally large ears." Lacking material from other Cumberland localities, he called the Eubank mice *auricularis*. Later, Hooper and Cady (Journ. Mamm. 22: 325. 1941) discovered the same characters in specimens from Cleveland, Virginia, on the eastern fringe of the plateau region, but referred their specimens to *P. p. scalopsoides*. Sufficient material is now available to show that the pine mouse of the Cumberland Plateau is quite distinct from surrounding populations. With regard to its habitation of a region particularly noted for coal, I have named it:

***Pitymys pinetorum carbonarius*, n. subsp.**

*Type*.—Old adult female in slightly worn winter pelage; skin and skull; U. S. N. M. no. 191204; collected February 14, 1888, at Eubank, Pulaski County, Ky., by John B. Lewis; original number 76.

*Distribution*.—The Austral and Transition Life Zones of southwestern Virginia, northeastern Tennessee, eastern Kentucky, extreme southeastern Ohio, and probably southern West Virginia (east to Russell County, Va., and Carter County, Tenn.; south to Jefferson and Campbell Counties, Tenn.; west to Pulaski County, Ky.; and north to Lawrence County, Ohio).

*Description*.—Type (capitalized color terms from Ridgway, 1912, *Color standards and color nomenclature*): Dorsum between Sanford's Brown and Argus Brown, overlaid with black; flanks, shoulders, cheeks, and sides of snout between Amber Brown and Tawny; belly and legs silvery

gray, washed with buff; upper surfaces of feet Hay's Brown with a silvery cast; tail brownish above, darker than feet, whitish below, with no clear line of demarcation between the colors. Size large; ears not completely concealed by fur. Skull of light construction, somewhat angular, not noticeably convex in dorsal profile; post-orbital protuberance of squamosal slightly developed; zygomatic arches light and parallel to one another; rostrum long and narrow; braincase long and wide; incisive foramina long and frequently narrowed posteriorly; and anterior margin of mesopterygoid fossa variable in outline, either U-shaped or V-shaped.

*Measurements* (in millimeters; average followed by extremes).—Ten adults (both sexes; including type) from Eubank, Ky.: Skin—total length, 125 (118–139); tail, 23 (19–26); hind foot, (no measurements available). Skull—greatest length, 25.6 (25.1–26.6); zygomatic breadth, 15.5 (14.9–16.6); least-interorbital width, 4.4 (4.1–4.6); nasal length (along mid-line), 7.8 (7.7–8.0); maxillary molar series (alveolar length), 6.4 (6.2–6.7); mastoidal breadth, 13.0 (12.3–13.6); braincase length (dorsal midpoint of foramen magnum to postorbital process of squamosal), 13.3 (13.0–13.6).

*Comparisons*.—This race is characterized in all pelages by dark and bright coloration of the dorsum, a consequence of the combination of black overlay and dark hue of the subapical band. It is the darkest known American population of *Pitymys*. Cranially it does not appear to be well differentiated; observed variations from other races are only average and are of small magnitude. With respect to the cranium, its closest relatives seem to be *P. p. auricularis* and *P. p. scalopsoides*. In many ways it is intermediate between these two forms. Resemblances to *P. p. pinetorum* are fewer. Geographically remote *P. p. nemoralis* and *P. parvulus* need not be considered in this discussion.

From *scalopsoides* the race *carbonarius* may be distinguished by much darker, brighter coloration of the dorsum, a greater amount of black on the tips of the dorsal guard hairs, less angular skull, less well developed postorbital protuberance of the squamosal, lighter zygomatics, longer rostrum, wider braincase, longer incisive foramina

<sup>1</sup> Published by permission of the Secretary of the Smithsonian Institution.

with a greater tendency toward posterior constriction.

The subspecies *auricularis* is nearly as dark as *carbonarius*, but the latter is brighter and has a more angular skull with a less convex dorsal profile, lighter and more parallel zygomata, longer and narrower rostrum, wider braincase, incisive foramina more frequently constricted posteriorly, and the anterior margin of the mesopterygoid fossa less constantly U-shaped.

In brightness, but not in darkness, *carbonarius* is approached by *pinetorum*. However, *carbonarius* has more black on the dorsal guard hairs, and has the subpalatal band of a darker, more intense color. Further, it is larger in all dimensions, and has the skull more angular and less convex in dorsal profile, the rostrum longer and narrower, the braincase longer and wider, the incisive foramina longer and more frequently constricted posteriorly, the anterior margin of the mesopterygoid fossa not so consistently V-shaped, and the auditory bullae more inflated and more pointed anteriorly.

*Remarks.*—Probably the characters of *carbonarius* are best developed in the Cumberland Mountains and adjacent plateau. In outlining the geographic range of this race, two areas have given particular difficulty: The Ohio Valley in the longitude of Ohio and the northeastern portion of the Tennessee River watershed. These are areas where the characters of several races of *Pitymys pinetorum* merge.

Bascom, Ind., is the easternmost locality along the Ohio River from which typical *auricularis* has been seen. Specimens from Brookville, Ind., are intermediate and nearer *scalopsoides*, while ones from Ripley, Ohio, are intermediate and nearer *auricularis*. Farther upstream, at Rome and Smokey Creek, Adams County, Ohio, material is again intermediate, but nearer *scalopsoides*. Still farther eastward, where the Ohio River swings nearest to the range of *carbonarius*, at Lawrence County, Ohio, the darkest Ohio *Pitymys* are to be found. These are like *auricularis*, but in view of the character of the specimens from localities down stream, nearer the center of the range of *auricularis*, I tentatively consider the scanty Lawrence County material to be intergrades between *scalopsoides* and *carbonarius*, but nearer the latter. The character of dark coloration may be traced farther north-eastward in the Ohio Valley to Belmont County, Ohio. Bole and Moulthrop (Sci. Publ. Cleveland

Mus. Nat. Hist. 5: 161. 1942) identified specimens from Cat Run in this county as *pinetorum*. I have examined material from Cat Run and find it only slightly darker than typical *scalopsoides* from southeastern New York. It can be referred without hesitation to *scalopsoides*.

In the Tennessee Valley, specimens from Cleveland, Va., are intermediate between *scalopsoides* and *carbonarius*, but nearer the latter. A single individual from Watauga Valley, Tenn., is referred to *carbonarius*, although it is paler than that race and shows intergradation toward *pinetorum* or *scalopsoides*. A series from Marshall, N. C., is somewhat darker than typical *pinetorum*, showing the influence of either *carbonarius* or *auricularis*, both of which are darker than *pinetorum*.

*Specimens examined.*—Specimens are in the U. S. National Museum or the U. S. National Museum, Biological Surveys collection, except as indicated by the following abbreviations: CMNH—Cleveland Museum of Natural History; CM—Charleston [S. C.] Museum; CU—Cornell University; MGFC—Mississippi Game and Fish Commission; UMMZ—University of Michigan Museum of Zoology. I am grateful to the authorities at these institutions for the loan of specimens.

*P. p. auricularis.*—INDIANA: Bascom, 5; Worthington, 1. KENTUCKY: Canner, 2; Monticello, 1. MISSISSIPPI: Copiah County, 2 (MGFC); Jones County, 1 (MGFC); Lincoln County, 2 (MGFC); Rankin County, 1 (MGFC); Washington, 4. NORTH CAROLINA: Cherokee County, 1 (UMMZ). OHIO: Ripley, 4 (CMNH). TENNESSEE: La Follette, 1.

*P. p. carbonarius.*—KENTUCKY: Eubank, 31; Quicksand, 1 (CU). OHIO: Hanging Rock, 1 (UMMZ); Symes Creek, Lawrence County, 1 (CMNH). TENNESSEE: High Cliff, 2; Jefferson County, 2 (CMNH); Watauga Valley, 1. VIRGINIA: Cleveland, 2 (UMMZ); Hurricane, Wise County, 6.

*P. p. pinetorum.*—NORTH CAROLINA: Bent Creek Experiment Station, Pisgah National Forest, 1; Madison County, 1 (CM); Marshall, 9 (CMNH). SOUTH CAROLINA: Abbeville, 1 (CM); Charleston, 5 (CM); Clemson College, 3 (CM); Frogmore, 1; Georgetown, 1 (CM); Summerville, 1 (CM).

*P. p. scalopsoides.*—INDIANA: Brookville, 3. NEW YORK: Suffolk County, 3; Ulster County, 7. OHIO: Cat Run, Belmont County, 15 (CMNH); Rome, Adams County, 7 (CMNH); Smokey Creek, Adams County, 1 (CMNH). VIRGINIA: Blacksburg, 2. WEST VIRGINIA: Gilboa, 2; Raymond City, 1; White Sulphur Springs, 11.

MALACOLOGY.—*Nomenclatural review of genera and subgenera of Chamidae.*DAVID NICOL,<sup>1</sup> U. S. National Museum.

Except for the excellent paper by Odhner (1919), which has not been carefully studied by most other workers, little research in systematics has been done on the Chamidae. Genera and species of this interesting pelecypod family have, in general, not been understood. Before giving a description of the family, it is necessary to point out the principal weakness of a nomenclatural review. There is always the possibility that one or more genera will be incorrectly allocated because the descriptions and figures are unrecognizable. The problem of inadequate descriptions and figures can be solved only by examining specimens of the type species.

The Chamidae have a porcellaneous shell which may have either concentric or radial ribs, and the shell may be spinose, nodulose, or smooth. The inner ventral border may be smooth or may have small crenulations. A sulcus is commonly present at the posterior fifth of the shell. It runs from the umbos to the posterior ventral border. The shell may be attached by either valve (more commonly the left one) to the substrate during a small part of or practically all of its life. The valves may be markedly unequal or only slightly so, but the attached valve is always the larger. There is no gape for the byssus, foot, or siphons. With the exception of *Echinochama*, which has a lunule, neither a lunule nor an escutcheon is present. The beaks are prosogyrate and are placed in front of the parivincular ligament. This structure is external but commonly sunken. The pallial line is integripalliate, with a small indentation where it joins the posterior adductor muscle scar. In some species the pallial line joins the anterior adductor muscle scar not at the ventral margin but along the anterior margin. The anterior adductor muscle scar commonly abuts the anterior margin of the hinge plate. The adductor muscle scars are large and either elongate or ovate. The pallial line and adductor muscles commonly resemble those of the lucinids. The hinge teeth in adult shells have been greatly modified by the torsion of the beaks

and secondary splitting, and there is little agreement as to the number of cardinal and lateral teeth in each valve. However, the basic pattern appears to be like that of a highly modified lucinoid hinge. One large cardinal tooth is present in each valve. In the attached valve, particularly in *Echinochama*, a much smaller cardinal tooth is located above and posterior to the large cardinal tooth. A small conical posterior lateral tooth is sometimes seen on the attached valve.

The following genera and subgenera are chamids, with type species whose morphologi characters correspond to those of the family, and whose names are nomenclaturally valid. This does not mean that all will be acceptable when careful work on the classification of the Chamidae is completed, but these names form a basis for future taxonomic work on the family.

- Chama* Linné, 1758, pp. 691,692. Type species (subsequent designation, Schumacher, 1817, pp. 20,123. See also Stewart, 1930, p. 33) *Chama gryphoides* Linné, 1758, Recent; Mediterranean Sea. Figd., Bucquoy, Dautzenberg, & Dollfus, 1892, pl. 50, figs. 1-4.
- Ciptyella* Vincent, 1930, pp. 111,112. Type species (original designation)—*Chama pulchra* Ravn, 1902, Danian, Paleocene; Denmark, Belgium. Figd., Vincent, 1930, pl. 6, fig. 12. *Ciptyella* is probably a chamid, although a careful study of the type species is necessary to ascertain this.
- Echinochama* Fischer, 1887, p. 1049. Type species (monotypy)—*Chama arcinella* Linné, 1767, Recent; West Indies. Figd., Reeve, 1847, vol. 4, *Chama* species 26, pl. 5, fig. 26a.
- Eopseuma* Odhner, 1919, pp. 25,75. Type species (monotypy)—*Pseudochama (Eopseuma) pusilla* Odhner, 1919, Recent; Strait of Macassar. Figd., Odhner, 1919, figs. 20-27.
- Maceris* Modeer, 1793, pp. 174,182. Type species (subsequent designation, Winckworth, 1935, p. 322)—*Chama lazarus* Linné, 1758, Recent; East Indies. Two species were referred to in the discussion of the genus *Maceris* (p. 182)—*Chama gryphus* Linné and *Chama lazarus* Linné. It is not certain whether Modeer meant *Chama gryphoides* Linné or *Anomia gryphus* Linné for the first species. Figd., Reeve, 1847, vol. 4, *Chama* species 4, pl. 2, figs. 4a, b.

<sup>1</sup>Published by permission of the Secretary of the Smithsonian Institution.

*Pseudochama* Odhner, 1917, pp. 28-34. Type species (subsequent designation, Prashad, 1932, p. 295)—*Chama cristella* Lamarck, 1819, p. 96, Recent; East Indies. *Chama cristella* has been considered the type species of *Pseudochama* by original designation and by monotypy. Neither of these ideas is correct. Odhner mentioned other species as belonging to *Pseudochama* in his original discussion of the genus. Figd., Reeve, 1847, vol. 4, *Chama* species 42, pl. 8, fig. 42.

The following generic and subgeneric names have been associated with the Chamidae in the past, but all of them appear to be unavailable from the evidence thus far obtained.

*Arcinella* Schumacher, 1817, pp. 47, 142. Type species (monotypy)—*Arcinella spinosa* Schumacher, 1817 = *Chama arcinella* Linné, 1767. A homonym of *Arcinella* Oken, 1815, which is a carditid genus.

*Camelaea* Herrmannsen, 1852, vol. 2 (supplement), p. 23. A genus without species. Herrmannsen refers to a work by P. F. Gmelin which has been rejected by the International Commission of Zoological Nomenclature, Opinion 123.

*Cameola* Rafinesque, 1815, p. 148. An emendation of the name *Chama* Linné, 1758.

*Camostrea* Deshayes, 1830, p. 178. A genus without species. Also a misinterpretation of Blainville's definition of the genus.

*Chamigenus* Renier, 1807, p. vii. Original reference not seen. Renier's names ending in *genus* have not been accepted by malacologists. For a good review of the problem, see Keen, 1951, pp. 8-15.

*Chamites* Gmelin, 1793, p. 402. The name *Chamites* is listed as a species under the genus *Helmintholithus*. Neave (1939, p. 668) and Schulze (1927, p. 630) are in error in considering *Chamites* of Gmelin as a generic name.

*Cipleyella* Neave, 1939, vol. 1, p. 740. Error for *Ciplyella* Vincent, 1930.

*Diceratia* Oken, 1815, p. 829. Type species (monotypy)—*Chama cor* Linné, 1767. *Diceratia* appears to be a synonym of *Isocardia* Lamarek, 1799, and *Glossus* Poli, 1795.

*Diceratis* Paetel, 1875, p. 69. Error for *Diceratia* Oken, 1815.

*Globus* Deshayes, 1832, p. 170. A genus without species and a homonym of *Globus* Scopoli, 1772.

*Goossensia* Cossmann, 1885, p. 113. Type species (monotypy)—*Goossensia plicatuloides* Cossmann, 1885, pp. 113-115. Probably not a

chamid; however, Dall's opinion (1903, p. 1397) that the genus is based on a nepionic shell of a chamid is certainly worthy of investigation. *Gryphus* Gray, 1847, p. 193. A genus without species. This name is listed under *Chama* and *Arcinella* and credited to Humphrey, as a manuscript name. A homonym of *Gryphus* Megerle, 1811, *Gryphus* Oken, 1816, among others.

*Hellia* Schafhäütl, 1863, pp. 160, 161. Type species (monotypy)—*Hellia gryphus* Schafhäütl, 1863. This species has been described from poorly preserved internal casts, but it probably does not belong to the family Chamidae. The right valve is supposedly larger than the left.

*Jataronus* Bruguière, 1792, p. 546. A genus without species. It is impossible, from the brief description, to define the genus.

*Lacinea* Sowerby, 1842, p. 168. A genus without species. Listed as a synonym of *Chama* Lamarck.

*Lazarus* Cuvier, 1800, table 5. A nomen nudum.

*Licinia* Gray, 1847, p. 193. A genus without species. This name is listed under *Chama* and *Arcinella* by Gray and credited to Humphrey, 1797, as *Licinia* sp. A homonym of *Licinia* Swainson, 1820.

*Macerophylla* Mörch, 1853, p. 36. A genus without species. Listed as a manuscript name of Martens.

*Macerophyllum* Herrmannsen, 1847, vol. 2, p. 1. A genus without species.

*Macrophyllum* Gray, 1847, p. 193. A genus without species. Also a homonym of *Macrophyllum* Gray, 1838.

*Psiloderma* Fischer, 1887, p. 1048. Error for *Psilopoderma* Poli, 1795.

*Psilopoderma* Poli, 1795, pp. 253, 258. Type species (monotypy)—*Chama gryphoides* Linné, 1758. A synonym of *Psilopus* Poli, 1795, and of *Chama* Linné, 1758.

*Psilopoderma* Agassiz, 1846, p. 313. Emendation of *Psilopoderma* Poli, 1795.

*Psilopus* Poli, 1795, p. 112. Type species (monotypy)—*Chama gryphoides* Linné, 1758. A synonym of *Chama* Linné, 1758.

*Psilotus* Rafinesque, p. 146. An error for *Psilopus* Poli, 1795.

*Stola* Herrmannsen, 1849, vol. 2, p. 503. A genus without species.

#### REFERENCES

- AGASSIZ, L. *Nomenclatoris zoologici index universalis, etc.*: 393 pp. Soloduri, 1846.  
 BRUGUIÈRE, J. G., LAMARCK, J. B., and DESHAYES, G. P. *Encyclopédie méthodique (Mollusca)*. Paris, 1789-1832.  
 BUCQUOY, E., DAUTZENBERG, PH., and DOLLFUS, G. *Les mollusques marins du Roussillon* 2 (7): 273-320. Paris, 1892.

- COSSMANN, M. *Description d'espèces du terrain tertiaire des environs de Paris (suite)*. Journ. Conchyl., 3d sér., **25** (2): 106-130, pls. 4-6. 1885.
- CUVIER, G. *Leçons d'anatomie comparée* **1**: 521 pp., 9 tab. Paris, 1800.
- DALL, W. H. *Contributions to the Tertiary fauna of Florida, etc.* Trans. Wagner Free Inst. Sci. Philadelphia **3** (6): 1219-1654, pls. 48-60. 1903.
- FISCHER, PAUL. *Manuel de conchyliologie, etc.*: 1369 pp., 23 pls., 1138 text figs. Paris, 1887.
- GMELIN, J. F. *Systema naturae*, ed. 13, **3**: 476 pp. Lipsiae, 1793.
- GRAY, J. E. *A list of the genera of Recent Mollusca, their synonyma and types*. Proc. Zool. Soc. London 1847: 129-219. 1847.
- HERRMANNSEN, A. N. *Indicis generum malaco-zoorium primordia*. Kassel, 1846-1852.
- KEEN, A. M. *The molluscan names in Renier's "Tavole"*. Nautilus **65** (1): 8-15. 1951.
- LINNÉ, KARL VON. *Systema naturae*, ed. 10, **1**: 824 pp. Holmiae, 1758.
- . *Systema naturae*, ed. 12, **1**: 1,327 pp. Holmiae, 1767.
- MODEER, ALDOLPH. *Indledning til kunskapen om Maskkraken i allmänhet; 5 Classen. Musslor, Cochleata*. Kongl. Svenska Vet. Acad. Nya Handl. **14**: 163-183. 1793.
- MÖRCH, A. O. L. *Catalogus conchyliorum. . . Yoldi; etc.*, fasc. 2: 74 pp. Hafniae, 1853.
- NEAVE, S. A. *Nomenclator zoologicus*, 5 vols. Zool. Soc. London, 1939-1950.
- ODHNER, NILS H. *Results of Dr. E. Mjöberg's Swedish Scientific Expeditions to Australia 1910-1913. XVI Mollusca*. Kungl. Svenska Vet.-Akad. Handl. **52** (16): 115 pp., 3 pls. 1917.
- . *Studies on the morphology, the taxonomy and the relations of Recent Chamidae*. Kungl. Svenska Vet.-Akad. Handl. **59** (3): 102 pp., 8 pls. 1919.
- OKEN, LORENZ. *Okens Lehrbuch der Naturgeschichte*. **3**: Zool., 1 Abt.: 842 pp. Leipzig, Jena, 1815.
- PAETEL, F. *Die bisher veröffentlichten Familien und Gattungsnamen der Mollusken, etc.*: 229 pp. Berlin, 1875.
- POLI, G. S. *Testacea Utriusque Siciliae, etc.* Parmae, 1791-1827.
- PRASHAD, B. *The Lamellibranchia of the Siboga Expedition, Systematic Part II. Pelecypoda (exclusive of the Pectinidae)*. Monograph 53c: 353 pp., 9 pls., 1 map. Leiden, 1932.
- RAFINESQUE, C. S. *Analyse de la nature ou Tableau de l'univers et des corps organisés*. Palerme, 1815.
- REEVE, L. A. *Monograph of the genus Chama*. Conchologia iconica **4**: London, 1847.
- REINER, S. A. *Tavole per servire alla classificazione e conoscenza degli animali*. Pavova, 1807.
- SCHAFHÜTL, KARL E. *Der Kressenberg und die Südlich von ihm gelegenen Hochalpen geognostisch betrachtet in ihren Petrefacten*. Süd-Bayerns Lethaea Geognostica: 487 pp., 86 pls., 2 maps. Leipzig, 1863.
- SCHULZE, F. E., KÜENTHAL, W., HEIDER, K., and HESSE, R. *Nomenclator animalium generum et subgenerum*. Berlin, 1926-1940.
- SCHUMACHER, C. F. *Essai d'un nouveau système des habitations des vers testacés*: 287 pp., 22 pls. Copenhagen, 1817.
- SOWERBY, G. B. *A conchological manual*, ed. 2; 313 pp., 26 pls. London, 1842.
- STEWART, R. B. *Gabb's California Cretaceous and Tertiary type lamellibranchs*. Acad. Nat. Sci. Philadelphia Spec. Publ. **3**: 314 pp., 17 pls. 1930.
- STILES, C. W. P. F. *Gmelin's Onomatologia Historia Naturalis Completa suppressed*. Smithsonian Misc. Coll. **73** (7): 34-36 (opinion 123). 1931.
- VINCENT, ÉMILE. *Études sur les mollusques Montiens du Poudingue et du Tuffeau de Ciplu*. Mus. Roy. Hist. Nat. Belgique Mém. **46**: 115 pp., 6 pls. 1930.
- WINCKWORTH, R. S. *Modeer's Genera of Mollusca*. Proc. Malac. Soc. London **21**: pt. 5, 321-323. 1935.

ENTOMOLOGY.—*A new carpenterworm from Florida (Lepidoptera: Cossidae)*.

J. F. GATES CLARKE, U. S. Bureau of Entomology and Plant Quarantine.

It is seldom that so large and conspicuous a moth as that described below remains undiscovered for so long a time, especially since it inhabits a well-populated area and a region frequented by entomologists. Nevertheless such is the case, and it is a further example of what yet remains to be done in many parts of the country. The larvae of this species were first reported by William Reimer, a medical student, and the type series was reared and submitted by Prof. H. F. Strohecker, Department of Zoology, University of Miami.

*Prionoxystus baccharidis*, n. sp.

Figs. 1-4b)

Alar expanse: Male, 34-43 mm. Female, 43-45 mm.

Antenna black with strong, metallic-blue iridescence above. Labial palpus, head, thorax, and ground color of forewing sordid white to cinereous, the lighter color prevailing in the female; palpus, head, and thorax with dark-gray and black scales mixed; forewing covered with a fine, black reticulum somewhat heavier in male than in female; costal black markings



exhibiting much metallic-blue iridescence; hindwing of male blackish fuscous except black-marked cinereous costa; hindwing of female pale cinereous with fine, somewhat obscured reticulum. Legs cinereous, banded with black, the latter color with strong, metallic-blue iridescence. Abdomen cinereous, strongly irrorate with black

and dark gray, and grayish fuscous above in male.

*Male genitalia*.—Symmetrical. Uncus broad, triangular. Lateral elements of gnathos broadly fused distally, flattened. Harpe, anellus, and aedeagus as figured; clasper arising at base of harpe with distal end free.

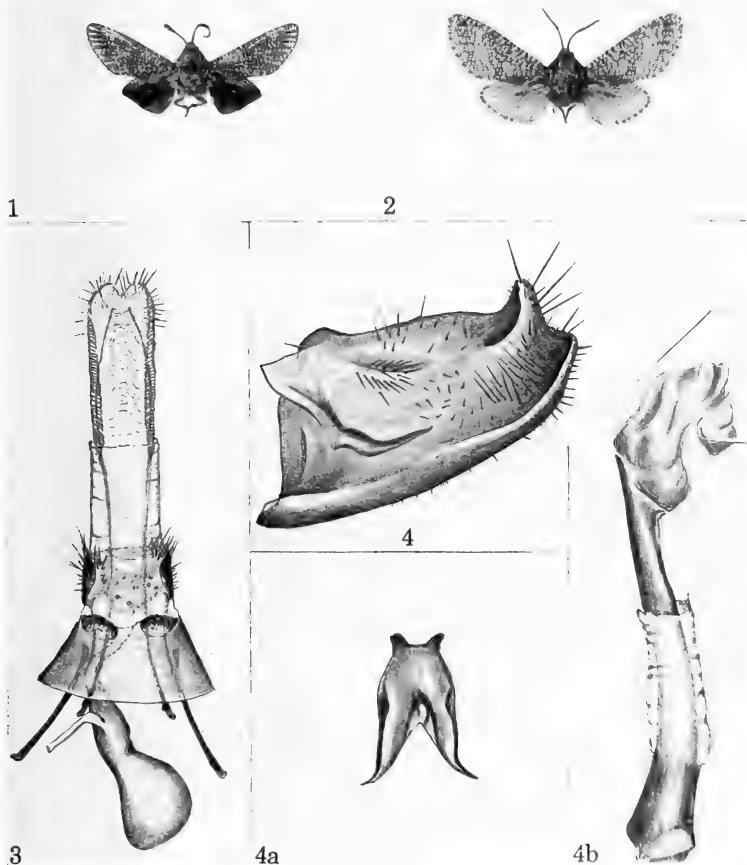

FIGS. 1-4b.—*Prionoxytus baccharidis*, n. sp.: 1, Male; 2, female; 3, ventral view of female genitalia; 4, right harpe; 4a, anellus; 4b, aedeagus.

*Female genitalia*.—As figured.

*Type*.—U.S.N.M. no. 61307.

*Type locality*.—Coral Gables, Dade County, Fla.

*Food plant*.—*Baccharis* sp.

*Remarks*.—Described from the type male and three male and two female paratypes from the type locality, all reared by Prof. H. F. Strohecker. All bear emergence dates of March 1951. Paratypes in the U. S. National Museum; Department of Zoology, University of Miami, Coral Gables, Fla.; and the British Museum (Natural History).

Previously the genus *Prionoxystus* was represented in North America by only two described species, *P. robiniae* (Peck) (carpenterworm) and *P. macmurtrei* (little carpenterworm). *P. baccharidis*, for which I suggest the common name "saltbush carpenterworm," is nearest *robiniae*, but is smaller, and the yellow hindwing of *robiniae* is replaced by the dark hindwing in *baccharidis*.

Of this species Professor Strohecker writes: "The specimens were bred from the trunks of the *Baccharis*. Roy Woodbury, of our botany department, tells me that the stand of *Baccharis*

from which I cut the pieces includes (my memory) four species. . . . The larvae occur most frequently in the bole near ground level but some of them were found in branches not much more than an inch in diameter. All the wood cut by me was from living bushes.

"The exact locality was an area near what is known locally as 'Tahiti Beach.' The mangrove growth near the bay is followed inland by a growth of saltbush. I don't know the history of this place, i. e., whether the saltbush is a 'natural' stand or sprang up after removal of such plants as white mangrove and buttonwood. Some of the *Baccharis* have trunks three or more inches in diameter but all are of low height.

"Last March I went to the site where he [Mr. Reimer] had found the larvae and cut several bushes. Those with large larvae can be detected by the exudations of sawdust from the borings. The little insects are of such powerful flight when adult that they quickly damage themselves in a cage."

The photographs for this paper were taken by Robert Bonde, of the U. S. Department of Agriculture. Drawings by the author. The figures are of the type male and a paratype female.

#### PALEONTOLOGY.—*Two new species of Sinclairocystis*. HARRELL L. STRIMPLE, Bartlesville, Okla. (Communicated by Alfred R. Loeblich, Jr.)

Subsequent to the finding of *Sinclairocystis* Bassler (1950), by Dr. G. A. Cooper and William Allen, of the U. S. National Museum, in Ordovician rocks of southeastern Oklahoma, the author and his wife, Mrs. Melba Strimple, have collected at the type locality on several occasions and have found several interesting forms of the "Cystoidea." Among these are two new species of *Sinclairocystis* described below. They lend considerable additional information concerning this unique genus.

##### *Sinclairocystis angulatus*, n. sp.

Fig. 5-9

Two recumbent arms are present, that to the left terminating near the columnar attachment, the right passing closely behind the anus and forming a loop to the posterior about the large posterior thecal plates and terminating high on the theca. On the antanal side of the left arm, food grooves are seen passing from the facets

for the brachioles to a more or less continuous groove along the length of the arm. The same process is present on the anal side of the right arm. One brachiole facet is present on each arm segment and no covering plates over the grooves have been observed.

There are three basal plates and four plates surrounding the anus. In the anal (posterior) side of the theca, an angulation occurs to the left, forming a more or less flattened surface in what might be termed the left posterior, and is bordered to the left by the left arm. In this restricted area there are only two large plates between the basal circlet and the plates adjacent to the anus. In the lateral wall of the posterior thecal plates are small, with four or five present between the basals and the summit platform which is bordered by the right arm. The right lateral side of the theca has two series of six small plates between the basals and the right arm. The antanal (anterior) is composed of slightly larger plates than those of the right side and considerably larger plates as the left arm

bearing ray is approached. In the first mentioned area, four or five plates are present between basals and those adjoining the anus and in the latter area only three. The left arm-bearing

ray is composed of three large and two small plates, including the basal and summit plates.

The anal opening is covered by a low pyramid-like cirrlet of five triangular shaped plates. What

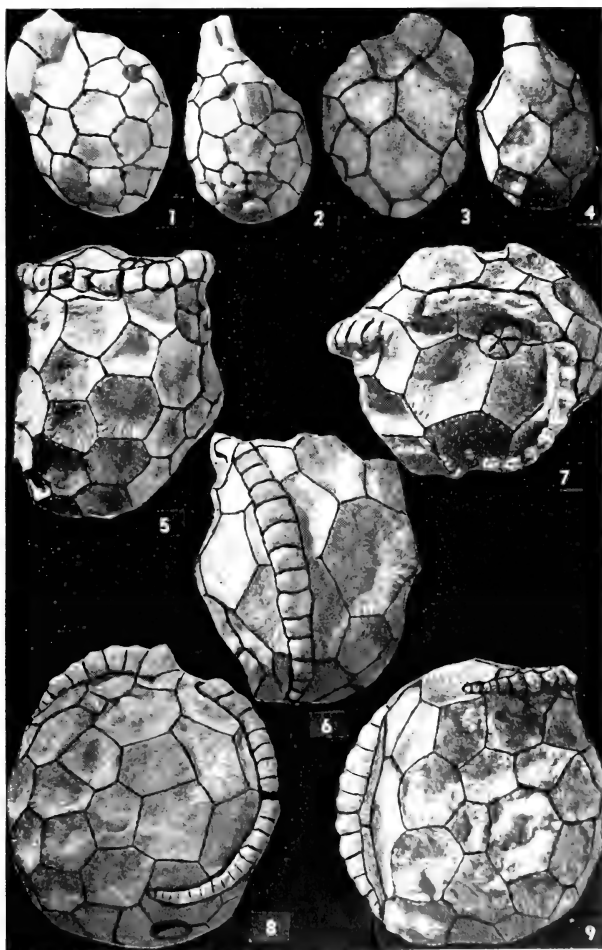

FIGS. 1-4.—*Sinclairocystis sulphurensis*, n. sp., posterior side, right side, anterior side and left side, X 4; FIGS. 5-9.—*Sinclairocystis angulatus*, n. sp., right side, left side, top view, anterior side and posterior side, X 2.5.

appears to be a small opening (hydropore?) occurs in the median portion of the first plate below the mouth on the antanal side of the theca and is marked by a tubercle like projection.

Most thecal plates are hexagonal, but several have five sides and a few have as many as seven sides. All except those of the anal pyramid have strongly depressed median sections and are marked by fine grooves, which are perpendicular to the sides of the plates. There is indication that near the sutures some grooves penetrate the theca. Granular ornamentation is present on all thecal plates except those of the anal pyramid.

Measurements of the holotype are as follows: Maximum height of theca (including arms), 20.2 mm; maximum width, 19.1 mm; diameter of anus, 2.5 mm; length of left arm, 24.6 mm; length of right arm, 28.2 mm.

*Remarks.*—*S. angulatus* is readily separable from *S. praedecta* Bassler (1950) in possession of more numerous thecal plates, a different shape to the theca, and the distinctive attitude of the right arm in the former species. In *S. praedecta*, the right arm curves down the right side of the theca with only slight curvature toward the posterior. In the present species the right arm forms an uncompleted circular loop, terminating high on the theca in posterior position. *S. sulphurensis* has the same arm placement as *S. praedecta* but differs in several respects from either species.

*Occurrence.*—Blackriverian (Bromide formation, near top of green shale), 1.8 miles south of Sulphur, Okla.

*Holotype.*—Collected by the author. To be deposited in the U. S. National Museum.

#### *Sinclairiocyclus sulphurensis*, n. sp.

Figs. 1-4

Theca is small, rotund in outline. A portion of the left arm is preserved which shows the proportionately large nature of these appendages. Most thecal plates are hexagonal but several have from five to seven sides. The larger plates are in the anterior where only two or three plates are interposed between the basals and the four plates adjoining the anus. Median portions of the thecal plates are shallowly depressed and round holes mark the sutures, particularly in the posterior and right sides of the theca. No ornamentation is present.

Measurements of the holotype are as follows: Maximum height of theca (including arm), 10.2 mm; maximum width of theca (excluding arms), 6.7 mm; diameter of anal opening, 1.2 mm.

*Remarks.*—*S. sulphurensis* differs from *S. angulatus* and *S. praedecta* in outline of theca, small size, and lack of ornamentation. The small number of thecal plates and the attitude of the arms indicates closer affinity to *S. praedecta* than to *S. angulatus*. The openings into the body cavity found along the sutures are not so numerous and have a circular outline as compared to the innumerable openings along the sutures of *S. praedecta*, which have rectangular outlines.

*Occurrence.*—Blackriverian (Bromide formation, near top of green shale), 1.8 miles south of Sulphur, Okla.

*Holotype.*—Collected by Mrs. Melba Strimple. To be deposited in the U. S. National Museum.

#### BOTANY.—*A new Nymphoides from Colombia*.<sup>1</sup> LYMAN B. SMITH, U. S. National Museum.

The present species is one of many recent novelties which indicate that the flora of the eastern Llanos of Colombia is still poorly known in spite of a great increase in collections by local and foreign botanists.

##### *Nymphoides flaccida* L. B. Smith, sp. nov.

Fig. 1

Foliorum laminis oblongis, basi cuneatis bis cordatis, flaccidis; corolla alba, lobis fimbriatis.

Plant submersed; stems elongate, 2.5 mm in diameter, bearing one to several leaves and a

cluster of flowers at the apex; petioles from very short on the largest leaves to 6 cm long on some of the smaller ones; blades oblong, slightly broader toward the cuneate to cordate base, broadly obtuse, flaccid with repand margins, 8 cm long, 2.5 cm wide, glandular; pedicels slender, 7 cm long, naked, glabrous; sepals linear, 6 mm long; corolla white, over 2 cm in diameter, its lobes long-fimbriate; fruit unknown.

Type in the Herbario Nacional Colombiano, collected in the Caño Quenane, eastern Llanos, Territory of Meta, Colombia, January 25, 1942, by A. Dugand and R. Jaramillo M. (no. 3121).

<sup>1</sup> Published by permission of the Secretary of the Smithsonian Institution.

Additional specimen examined: COLOMBIA: Meta: In the Caño de Peralonso, vicinity of Villavicencio, eastern Llanos, alt. 450 m, July 24-28, 1946, *Jaramillo, Mesa, Idrobo, & Fernández* 362 (US).

The flowers of *Nymphoides flaccida* are much like those of *N. humboldtiana* (H.B.K.) Kuntze, but the great contrast in their leaves without any intermediate variation makes it seem fairly certain that they are distinct.



FIG. 1.—*Nymphoides flaccida*: a. Part of the type showing the only complete flower,  $\times 1$ ; b. part of *Jaramillo et al.* 362 showing variation of leaves and a well-developed umbel,  $\times \frac{1}{2}$ .

## PROCEEDINGS OF THE ACADEMY

### 445TH MEETING OF BOARD OF MANAGERS

The 445th meeting of the Board of Managers, held in the Cosmos Club on March 12, 1951, was called to order at 8:04 p.m. by the President, NATHAN R. SMITH. Also present were: W. RAMBERG, H. S. RAPPLEYE, J. A. STEVENSON, W. F. FOSHAG, A. T. MCPHERSON, C. F. W. MUESEBECK, SARA E. BRANHAM, E. U. CONDON, W. R. WEDEL, L. H. ADAMS, E. H. WALKER, W. A. DAYTON, C. A. BETTS, L. A. SPINDLER, A. M. GRIFFIN, H. W. HEMPLE, F. M. DEFANDORF, and, by invitation, MARGARET PITTMAN, J. R. SWALLEN, and G. P. WALTON.

A letter of resignation from the Chairman of the Committee on Membership, L. A. SPINDLER, was read. The following report of the Committee on the Encouragement of Science Talent was read and approved:

This Committee judged the papers submitted from the District of Columbia schools in the Tenth Science Talent Search conducted by the Science Clubs of America. The following were selected for recommendation as winners:

PAUL E. CONDON—Paper 920—Iron-Type Chemical Heaters

CECILIA GREEN—Paper 1600—Potential Difference in a Conducting Solution

DONALD L. MILLER—Paper 1698—Observation of Meteors

JOSEPH M. CALDWELL, *Acting Chairman*

The President read a letter from W. N. FENTON, Chairman of the Committee on the Index of the Journal, recommending appointment of a committee to consider and implement publication of the index as prepared in card index form by Mary A. Bradley. The Board voted that the President appoint a Committee on Ways and Means of Publishing the Index.

The Board elected MARTIN A. MASON to be Vice-President of the Academy representing the District of Columbia Section of the American Society of Civil Engineers following the reading of a letter dated March 6 from C. J. STEVENS, President of the District of Columbia Section, that nominated Mr. Mason as its candidate.

The following deaths of members of the Academy were reported: MAURICE I. SMITH, on January 26, 1951 (elected May 5, 1939); OWEN B. FRENCH, on February 12, 1951 (elected March 8, 1915); CLARIBEL R. BARNETT, on March 6, 1951 (elected June 13, 1933).

A discussion of increasing the age limit beyond 40 years for nominees for Awards for Scientific Achievement and of granting more than one annual award in each of the three different categories did not result in any recommendation requiring action by the Board.

After discussion the Board voted to discontinue sending engraved certificates of membership to newly elected members. The President was instructed to appoint a committee to consider costs and make recommendations to the Board on the type of certificate and preferred method of reproduction of Certificates of Merit.

#### 446TH MEETING OF BOARD OF MANAGERS

The 446th meeting of the Board of Managers, held in the Cosmos Club on April 16, 1951, was called to order at 8:03 p.m. by the President, NATHAN R. SMITH. Also present were: W. RAMBERG, H. S. RAPPLEYE, J. A. STEVENSON, CHARLES DRECHSLER, C. L. GAZIN, A. T. MCPHERSON, SARA E. BRANHAM, W. R. WEDEL, E. H. WALKER, W. A. DAYTON, L. A. SPINDLER, H. W. HEMPLE, F. M. DEFENDORF, and, by invitation, MARGARET PITTMAN, J. R. SWALLEN, G. P. WALTON, L. E. YOCUM, and M. A. MASON.

The President announced the following appointments:

(1) E. H. WALKER, of the Smithsonian Institution, as Chairman of the Committee on Membership, in lieu of L. A. SPINDLER, whose resignation was accepted at the last meeting.

(2) Committee on Indexing of the Journal: JOHN E. GRAF, Chairman, WILLIAM N. FENTON, C. F. W. MUESEBECK, PAUL H. OESER, J. A. STEVENSON.

Chairman Pittman of the Committee on Meetings reported that the May meeting would be addressed by D. J. Parsons of the Federal Bureau of Investigation, on *Science in crime detection*.

Chairman MASON of the Committee for En-

couragement of Science Talent reported on the part taken by members of the Academy in judging exhibits at the Annual Science Fair, and that President SMITH would present awards to the winners at the Science Fair Awards Meeting on April 18 to be held in the evening at the Department of Commerce Auditorium. The Washington Daily News will pay expenses of the winners for a trip to the National Science Fair to be held in St. Louis on May 10, 11, and 12.

The Secretary reported the death of BAILEY E. BROWN on March 9, 1951, and of MERRILL BERNARD on April 13, 1951.

The Treasurer reported contributions of \$25 for support of publication of the Science Calendar in local newspapers.

#### 447TH MEETING OF BOARD OF MANAGERS

The 447th meeting of the Board of Managers held in the Cosmos Club on May 14, 1951, was called to order at 8:02 p.m. by the President, NATHAN R. SMITH. Also present were: H. S. RAPPLEYE, J. A. STEVENSON, C. L. GAZIN, SARA E. BRANHAM, E. H. WALKER, W. A. DAYTON, C. A. BETTS, L. A. SPINDLER, A. M. GRIFFIN, F. M. DEFENDORF, and, by invitation, J. R. SWALLEN, G. P. WALTON, L. E. YOCUM, W. N. FENTON, and J. E. GRAF.

By invitation, J. E. GRAF, Chairman, and W. N. FENTON, Secretary of the special Committee on Indexing the Journal, presented a preliminary report for their committee. This report was discussed in considerable detail and on motion was accepted with appreciation and referred to the Executive Committee.

The Secretary reported the death of W. F. ALLEN.

The Treasurer read a letter of resignation from L. R. HAFSTAD which was approved as of January 1, 1951. The Treasurer reported that a total of about \$40 had been received from affiliated societies in support of the Science Calendar.

#### 448TH MEETING OF BOARD OF MANAGERS

The 448th meeting of the Board of Managers, held in the Cosmos Club June 18, 1951, was called to order at 8:00 p.m. by the President NATHAN R. SMITH. Also present were: H. S. RAPPLEYE, J. A. STEVENSON, H. A. REHDER, CHAS. DRECHSLER, A. T. MCPHERSON, C. F. W. MUESEBECK, SARA E. BRANHAM, J. J. FAHEY, F. W. POOS, W. A. DAYTON, L. A. SPINDLER, F. M. DEFENDORF, and, by invitation, MARGARET PITTMAN, PAUL H. OESER, G. P. WAL-

TON, J. E. GRAF, MISS PATTERSON (Science Service), MR. WAGNER (Dupont Theatre), KEITH JOHNSON (Woodrow Wilson Jr. High School).

Miss Patterson and Messrs. Johnson and Wagner outlined the plan of a benefit premier showing of the film *Kon-Tiki*. It is supposed that the Polynesian Islands may have been originally settled by Peruvians who floated on a raft constructed of balsa wood and bamboo and eventually drifted to those islands. Thus a Norwegian group led by Mr. Thor Heyerdahl constructed a raft and after drifting at the mercy of the prevailing winds and ocean currents for 101 days eventually landed in Tahiti. This feat is considered to afford some credulity in the original thesis of settlement of the Polynesians by Peruvians. The film *Kon-Tiki* is based on this voyage by raft.

After some discussion the Board accepted the proposal that the Washington Academy of Sciences sponsor the premier showing of the film at the Dupont Theatre in Washington for the benefit of the Science Fair Fund.

The Secretary presented a report of the meeting of the Executive Committee that immediately preceded this Board Meeting. Minutes of this meeting are as follows:

Meeting of the Executive Committee in the Cosmos Club Library was called to order at 7:30 p.m. by the President. In attendance: N. R. SMITH, H. S. RAPPLEYE, J. A. STEVENSON, F. M. DEFANDORF.

President Smith reviewed details relative to the proposed publication of the Index of the Journal. He stated that an approximate cost of \$6,000 for publication in addition to the \$1,500 already expended for the preparation of the card file index by Miss Bradley could be expected on the basis of detailed estimate received by the Special Committee on Indexing the Journal.

Ways and means of reducing the net cost of publication and other details were discussed, and as a result of the deliberation it was decided to recommend to the Board, on the basis that solicitations for outside help would be made in order to reduce the net cost to the Academy, that the index should be published if it could be done at a total cost not to exceed \$6,000.

Mr. GRAF reported for the Special Committee on Indexing the Journal, and after reading a letter from MRS. LEILA F. CLARK, Librarian of the Smithsonian Institution, telling of the value that such a printed index would be to librarians, called upon Mr. OEHSE to present firm estimates of the cost of printing the index. Detailed

estimates had been prepared that indicated a cost of \$5,705 for 1,000 copies if printed by letter press and \$6,053 if printed by offset press methods.

Dr. REHDER as Custodian presented a résumé of the inventory of complete and incomplete sets of the JOURNAL and mentioned a gift of an almost complete set from the Library of the American Optical Co.

Dr. SARA E. BRANHAM presented a summary of thoughts in regard to the activities and responsibilities of the Academy for consideration in the fall.

#### 49TH MEETING OF BOARD OF MANAGERS

The 449th meeting of the Board of Managers, held in the Cosmos Club on October 15, 1951, was called to order at 7:59 p.m. by the President, NATHAN R. SMITH. Others in attendance were: WALTER RAMBERG, H. S. RAPPLEYE, J. A. STEVENSON, CHARLES DRECHSLER, C. L. GAZIN, A. T. MCPHERSON, MILTON HARRIS, SARA E. BRANHAM, JOSEPH J. FAHEY, E. H. WALKER, W. A. DAYTON, C. A. BETTS, R. S. DILL, L. A. SPINDLER, A. M. GRIFFIN, H. G. DORSEY, M. A. MASON, F. M. DEFANDORF, and, by invitation, MARGARET PITTMAN, G. P. WALTON, and L. E. YOCUM.

Dr. YOCUM, Chairman of the Committee on Grants-in-Aid for Research, presented his committee's recommendations in a letter to the President dated October 12, 1951, as follows:

Your committee on grants in aid for research submits the following report and recommends favorable action:

For purchase of a curved barium titanite ultrasonic transducer by Dr. Karl H. Langenstross and Dr. Francis E. Fox. Amount \$170.

For purchase of nonmetallic plastic cages for metabolism studies by Dr. Martin Rubin and Dr. M. X. Sullivan.

For purchase of Bakelite and other resins for making models to study stress by a photoelastic polariscope by C. H. Walther. Amount \$75.

The Board voted to approve the allotments in the amounts and for the projects recommended.

Mr. MASON, Chairman of the Committee on Encouragement of Science Talent, reported that the benefit premiere performance of the film *Kon-Tiki* resulted in a net balance of \$776.22. The Board authorized the Treasurer to turn over the proceeds to Science Service for use in connection with the Science Fair activities.

Dr. MCPHERSON reported that the 6th Annual Science Fair, to be held in Washington this year,

would make use of facilities at the Catholic University for showing the exhibits. It is felt that this location will be satisfactory because of the ample space available for exhibits and for automobile parking.

President SMITH read a memorandum from Past President GRAF, Chairman of the Special Committee on Indexing the Journal, relative to incorporation of an index of the earlier Proceedings with the index of the Journal. The estimated additional cost is \$200. President SMITH stated that since this matter had been brought up subsequent to the June meeting, he had polled the Executive Committee, and on the basis that they were 4 to 1 in favor of including the indexing of the Proceedings, he had ordered inclusion of this additional material. The Board voted to affirm this action of the Executive Committee.

President SMITH read a letter from Dr. COONS, a member of the Committee on Awards for Scientific Achievement, outlining reasons why the age limit should be raised to 45 for such awards. Dr. VAN EVERA had made similar recommendations relative to the Science Teaching Award. It was pointed out in the latter instance that one teacher, now over 40, who has done remarkable work, would have received recognition earlier had the Award for Teaching of Science been established as early as the awards for other science groups. The President will ask Dr. VAN EVERA to attend the next meeting of the Board.

#### 450TH MEETING OF BOARD OF MANAGERS

The 450th meeting of the Board of Managers, held in the Cosmos Club on November 19, 1951, was called to order at 8:03 p.m. by the President, NATHAN R. SMITH. Also in attendance were: WALTER RAMBERG, J. A. STEVENSON, CHARLES DRECHSLER, W. F. FOSHAG, C. L. GAZIN, A. T. McPHERSON, J. J. FAHEY, F. W. POOS, E. H. WALKER, W. R. WEDEL, F. M. DEFENDORF, and, by invitation, MARGARET PITTMAN, L. E. YOCUM, J. I. HOFFMAN, and J. P. E. MORRISON.

Dr. Pittman announced that arrangements had been completed for Dr. WILLIAM E. HIATT, of the Weather Bureau, to speak at the December 20 meeting, on *Precipitation and the water supply*.

President Smith read a letter and report from Mr. GRAF, Chairman of the Committee on Indexing the Journal. The following are excerpts from the report, dated November 16, 1951:

#### TO THE BOARD OF MANAGERS:

The Committee on the Index is glad to be able to report progress on the job assigned to it by the Board of Managers—seeing through to completion the publication of the Index to the first 40 volumes of the Journal of the Academy. As authorized by the Executive Committee, Volumes 1-13 of the Proceedings (the Academy's publication antedating the Journal) have been included; the additional cards have been inserted; and the whole index, comprising 16,570 entries, is now ready to be turned over to the printer.

Bids for the printing of the Index have been obtained from 4 printing firms, 3 in Baltimore and 1 in Lancaster, Pa. (1 Washington printer declined to bid.) The lowest bid, in the amount of \$5,928.40, came from the Lord Baltimore Press. As this figure is only a few dollars under the amount that the Board has authorized to be spent on the Index, the Committee has decided to alter the specifications to allow use of a non-rag paper instead of a 50-percent rag stock originally stipulated. This will effect a saving of \$300-\$400 and thus allow a little more leeway for contingencies. Contract for the printing of the book will be awarded to the Lord Baltimore Press, and it is expected that the copy will be in the printer's hands within the next week.

In authorizing the publication of the Index, at its meeting on June 18, 1951, the Board moved that 'steps be taken to secure outside funds to minimize the net cost to the Academy.' The Index Committee is agreed that the task of raising such funds is definitely outside its province, but feels that the Board might welcome some suggestions pertinent to the problem. In the first place, the Committee thinks that the Academy's constituent societies should all be approached for contributions, in proportion to their interest and resources. All these societies have a stake in the Academy, and they should be given an opportunity to express in a tangible way their broader interests in Washington science, or perhaps to reaffirm such interests. In the second place, certain sources outside of Washington might be explored. The Committee is placing in your hands drafts of two letters that follow up these suggestions.

The Secretary read the report of the Nominating Committee, as follows:

The Nominating Committee, consisting of the Vice-Presidents of the Academy, met in the Library of the Cosmos Club on October 15, 1951. The meeting was called to order at 9:15 p.m. by JOSEPH J. FAHEY, who, as Vice-President for the Washington Section, American Chemical Society, presided as chairman. Others present were: E. H. WALKER, WM. A. DAYTON, C. A. BETTS, R. S. DILL, L. A. SPINDLER, A. M. GRIFFIN, HERBERT G. DORSEY, MARTIN A. MASON, F. M. DEFENDORF.

The nominees selected for the offices to be filled by balloting of the membership in December were as follows:



*For President-Elect*—F. M. SETZLER

*For Secretary*—FRANCIS M. DEFANDORF

*For Treasurer*—HOWARD S. RAPPLEYE

*For the Board of Managers:*

To serve from January 1952 to January 1953 to fill vacancy of H. P. Barss, resigned:—C. F. W. MUESEBECK

To serve from January 1952 to January 1954 to fill vacancy of J. A. Stevenson, resigned:—MILTON HARRIS

To serve from January 1952 to January 1955 (two to be elected):—ROGER G. BATES, ELOISE B. CRAM, W. W. DIEHL, JAMES I. HOFFMAN

JOSEPH J. FAHEY, *Chairman.*

F. M. DEFANDORF, *Secretary.*

President SMITH announced that he was retiring from his work in the U. S. Department of Agriculture on November 30, 1951, and was leaving Washington and moving to Florida, so that he would not be present at the next meeting. He expressed his appreciation to members of the Board and his Committees for their co-operation and good effort on behalf of the Academy. He then declared the formal meeting adjourned at 9:15 p.m. after inviting those present to remain for refreshments he had provided in the adjoining room.

#### 451ST MEETING OF BOARD OF MANAGERS

The 451st meeting of the Board of Managers, held in the Cosmos Club on December 17, 1951, was called to order at 8:02 p.m. by President-Elect WALTER RAMBERG. Others in attendance were: H. S. RAPPLEYE, J. A. STEVENSON, CHARLES DRECHSLER, SARA E. BRANHAM, W. R. WEDEL, F. W. POOS, E. H. WALKER, W. A. DAYTON, L. A. SPINDLER, A. M. GRIFFIN, F. M. DEFANDORF, and, by invitation, F. W. HOUGH, MARGARET PITTMAN, J. R. SWALLEN, and J. P. E. MORRISON.

Chairman PITTMAN, of the Committee on Meetings, discussed the Academy's Annual Dinner Meeting to be held on January 17 and announced that THOMAS R. HENRY had been chosen as speaker and would show the film *The Secret Land*.

Dr. WALKER presented nominations for membership and expressed appreciation of the work of the Committee on Membership, of which he is Chairman. He discussed what might be done to increase the active membership.

The Secretary explained that the additional nomination for President-Elect of ALAN T. WATERMAN appearing on the election ballot was the result of a nominating petition signed by 38 members of the Academy.

The Board accepted the resignation of Capt.

H. W. HEMPLE as Vice-President representing the Society of Military Engineers and elected in his place Col. F. W. HOUGH.

The Secretary mentioned several requests for exchange of journals with other organizations, which had to be refused inasmuch as the Academy does not maintain a library of its own.

The Treasurer told of the receipt of options in the case of two securities owned by the Academy and explained that no Board action was necessary.

[For minutes of 452d meeting of Board of Managers, see April 1952 issue of JOURNAL, p. 135.]

#### 453D MEETING OF BOARD OF MANAGERS

The 453d meeting of the Board of Managers, held in the Cosmos Club on February 18, 1952, was called to order at 8:03 p.m. by President RAMBERG. Other present were: F. M. SETZLER, H. S. RAPPLEYE, J. A. STEVENSON, W. F. FOSHAG, A. T. MCPHERSON, C. F. W. MUESEBECK, SARA E. BRANHAM, MILTON HARRIS, W. W. DIEHL, A. G. MCNISH, W. R. WEDEL, J. K. TAYLOR, F. W. POOS, L. M. HUTCHINS, W. A. DAYTON, C. A. BETTS, A. H. SCOTT, F. W. HOUGH, H. G. DORSEY, F. M. DEFANDORF, and, by invitation, E. H. WALKER, H. W. WELLS, W. N. FENTON, J. R. SWALLEN, L. E. YOCUM, J. P. E. MORRISON, W. T. READ, N. S. DRAKE, and W. L. SCHMITT.

The President announced appointment of the following committeemen for 1952:

*Appointed Members of Executive Committee:* F. M. SETZLER, WILLIAM A. DAYTON.

*Board of Editors of the Journal:* WILLIAM F. FOSHAG, Senior Editor; J. C. EWERS, replacing CHARLES DRECHSLER; PHILIP DRUCKER, Associate Editor for a term of 3 years, representing the Anthropological Society of Washington; J. I. HOFFMAN, Associate Editor for a term of 3 years, representing the Chemical Society of Washington.

*Committee on Membership:* E. H. WALKER (Chairman), M. S. ANDERSON, R. C. DUNCAN, G. T. FAUST, I. B. HANSEN, D. B. JONES, DOROTHY NICKERSON, F. A. SMITH, HEINZ SPECHT, H. M. TRENT, ALFRED WEISSLER.

*Committee on Meetings:* H. W. WELLS (Chairman), WM. R. CAMPBELL, W. R. CHAPLINE, D. J. DAVIS, H. G. DORSEY, O. W. TORRESON.

*Committee on Monographs:* W. N. FENTON (Chairman). To January 1955—W. N. FENTON, ALAN STONE.

*Committee on Awards for Scientific Achievement:* J. R. SWALLEN, General Chairman.

*For the Biological Sciences:* J. R. SWALLEN (Chairman), L. M. HUTCHINS, MARGARET PITTMAN, F. W. POOS, L. P. SCHULTZ.

*For the Engineering Sciences:* R. C. DUNCAN (Chairman), A. C. FIELDNER, WAYNE C. HALL, J. W. MCBURNEY, O. S. READING, H. L. WHITEMORE.

*For the Physical Sciences:* L. A. WOOD (Chairman), P. H. ABELSON, F. S. DAFT, GEORGE W. IRVING, JR., J. H. McMILLEN.

*For the Teaching of Science:* M. A. MASON (Chairman), F. E. FOX, M. H. MARTIN.

*Committee on Grants-In-Aid for Research:* L. E. YOCUM (Chairman), H. N. EATON, K. F. HERZFELD.

*Committee on Policy and Planning:* W. A. DAYTON, Chairman. To January 1955—L. W. PARR, F. B. SILSBEE.

*Committee on Encouragement of Science Talent:* A. T. MCPHERSON, Chairman. To January 1955—A. T. MCPHERSON, W. T. READ.

*Committee of Auditors:* C. L. GAZIN (Chairman), LOUISE M. RUSSELL, D. R. TATE.

*Committee of Tellers:* GEORGE P. WALTON (Chairman), GEORGE H. COONS, C. L. GARNER.

The President then called on Dr. A. T. MCPHERSON, Chairman of the Committee on Encouragement of Science Talent, who presented a report for his committee dated February 18, 1952, as follows:

The Committee on the Encouragement of Science Talent presents the following nominations for junior awards for scientific achievement:

WILLIAM WESTON HOOKER, of Anacostia High School, for studies of Pascal's triangle.

ROWLAND SANDER JOHNSON, of Coolidge High School, for studies in electronics.

JOHN ERRETT LANKFORD, of McKinley High School, for observations on variable stars.

JOEL SHAPPIRIO, of Woodrow Wilson High School, for studies on crystal modification.

STUART JOSEPH YULL, of McKinley High School, for studies on radar equipment.

ROBERT STEPHEN ZIERNICKI, of Priory School, for studies on chemical spectroscopy.

The foregoing candidates were selected from among the entries from District of Columbia Schools in the Eleventh Annual Science Talent Search of the Science Clubs of America sponsored by Westinghouse Educational Foundation and administered by Science Service.

The Board approved the award of Certificates of Merit for those nominated. In the discussion it was pointed out that Chairman McPherson will take up the matter of including students of high schools in the suburban area of metropolitan Washington for consideration next year in making such awards. Arrangements will have to be worked out with the Academies in Maryland and Virginia, since under present arrangements for Science Talent Search, areas outside of the District of Columbia, in nearby Maryland and Virginia, are not grouped with the District.

Chairman McPherson then expressed the concern of his committee with (1) the need for increasing the interest of students in science, (2) the need for allocation of adequate time for laboratory work in science courses, (3) the need of help that might be easily provided by members of the Academy in the form of lectures, etc., for science teachers, and (4) the need for action in encouraging teachers of science in high schools. He expressed the opinion that another committee, arranged for top-level participation, is highly desirable to take care of such a project. In order that the Board might become properly informed about the shortage of engineering and scientific manpower in relation to the national need for increased interest in scientific education in the high schools, Chairman McPherson introduced Dr. W. T. READ, Chairman of the Education Committee of the D. C. Council of Engineering and Architectural Societies, and Prof. N. S. Drake, of the Council of the Chemical Society.

Dr. Read spoke of the meeting of the Engineers Joint Council, Commission on Engineering Manpower, on September 28, 1951, attended by representatives from 28 States. A serious manpower shortage exists not only in engineering but also in the fields of science and mathematics upon which engineering depends. This shortage will become even more acute because student registration for courses in these fields has dropped to alarmingly low numbers. This deplorable trend away from mathematics and science courses in schools in the District and in suburban Maryland and Virginia follows the national trend. The need for cooperation of the Academy and its affiliated societies with the D. C. Council in an endeavor to improve the situation was stressed. It was suggested that continuing and concerted effort must be made to interest more capable and highgrade students to take science and mathematics courses with the view that more should enter scientific and engineering professions. The immediate need is to provide each high school in the metropolitan area with help from those in the professions who can stimulate the necessary interest. We must insure by effective methods that suitable courses of instruction are made available to capable high school students. Individual engineers and scientists with ability must therefore assume additional obligations in their communities to make known the needs of an adequate program. They must individually enlist aid through Parent-Teachers

Associations and other civic agencies and see that they are concerned about adequate support for teachers and provision of proper facilities for instruction. In short, the seriousness of this trend of students away from the pursuit of engineering and scientific careers must be counteracted.

Dr. Read spoke of the effort the national engineering groups are devoting to this problem; notably as an example \$10,000 has been provided by the American Society of Metals. He feels that to meet the immediate emergency the help of one engineer and one scientist in every high school this spring should be the goal. His committee is attempting to list people who are willing to work (1) by meeting and advising students; (2) by serving on committees on curricula and the standing of teachers; (3) by speaking on scientific subjects before science clubs; (4) through PTA groups where they have children in schools and can work effectively within such groups.

Professor Drake concluded the discussion by emphasizing the need for excellent instruction in basic mathematics courses. He emphasized that primarily students at this age need to be taught to think and to recognize how scientific problems are approached. Students who show latent ability in science need encouragement lest they be diverted to other less exacting fields of endeavor. Thus well trained teachers are essential.

The ensuing discussion by Board members helped to emphasize the lack of requirements for adequate training in mathematics and science in local high schools.

On motion, the President was directed to appoint a Committee on Scientific Education, to cooperate on behalf of the Academy with the D. C. Council of Engineering and Architectural Societies in their effort to achieve in high schools in the metropolitan area adequate courses and interest among qualified students in mathematics and science.

The Secretary read the Budget submitted for 1952 by the Treasurer, and recommended by the Executive Committee for submission to and adoption by the Board of Managers:

*Receipts*

	1951	Estimated 1952
Account of dues.....	\$4244.84	\$4300.00
Subscriptions to JOURNAL.....	1519.88	1600.00
Interest & dividends sales.....	2372.67	2000.00
	179.89	500.00
Affiliated societies for Science Calendar...	61.09	50.00
<b>Totals.....</b>	<b>\$8378.37</b>	<b>\$8450.00</b>

*Disbursements*

JOURNAL and JOURNAL office.....	\$6500.49	\$8850.00
Secretary's office.....	394.67	550.00
Treasurer's office.....	262.12	300.00
S.M. & C. of Pubs.....	44.35	50.00
Archivist.....	30.00	20.00
Meetings Committee.....	256.65	500.00
Membership Committee.....	—	20.00
Science Fair.....	100.00	100.00
Science Calendar.....	55.00	60.00
<b>Totals.....</b>	<b>\$7643.28</b>	<b>\$8450.00</b>

This budget is the same as for 1951 except that the JOURNAL allotment has been increased \$350; the Archivist's allotment has been decreased \$55; and the Science Calendar allotment increased \$10.

In the ensuing discussion, Senior Editor FOSHAG mentioned the desirability of increasing the number of pages published in the JOURNAL, suggesting that it be increased by say four additional pages in three issues per year. He also recommended that the Managing Editor, who takes care of much editorial detail, should receive increased compensation. A motion was passed to increase the compensation for work of the Managing Editor from \$25 to \$40 per month. The Board of Managers then voted to accept and adopt the Budget for 1952 as presented by the Treasurer.

Mr. WELLS, Chairman of the Committee on Meetings, announced that the Awards meeting would be held in March. Probably one meeting will be devoted to a discussion of the problem of developing adequate scientific manpower.

Affiliation of the District of Columbia Section of the Society for Experimental Biology and Medicine was unanimously approved.

F. M. DEFENDORF, *Secretary*.

## Obituary

CLARIBEL RUTH BARNETT was born in Kent, Ohio, on March 26, 1872, the daughter of George and Lucina (Deuel) Barnett. Her father was of English birth but had come to this country as a young man. She had a happy childhood in Kent

and always retained a great affection for it, often recalling the games and adventures in which she seems to have been a leader. Her education was begun in the Kent public schools, and she prepared for college at Western Reserve Academy

in Hudson, Ohio. She was graduated from the University of Michigan in 1893, with the Ph.B. degree, and later received a membership in Phi Beta Kappa from that university. In October 1893 she entered the New York State Library School at Albany, and in the spring of 1895 she took and passed the Civil Service examination for cataloger in the U. S. Department of Agriculture Library.

In the year 1907 Secretary of Agriculture James Wilson appointed Miss Barnett to the position of librarian, which she held until her retirement in November 1940. Her interests were by no means limited to her own library. Cooperative undertakings made a special appeal to her, and realizing the need for greater cooperation among agricultural libraries she was responsible for organizing the Agricultural Libraries Section of the American Library Association. Another form of mutual help is found in the emphasis placed on inter-library loans. The main source of such loans to her own library was the Library of Congress, together with the other special government libraries. The largest class of borrowers from her own library were the State agricultural colleges and experiment stations, but loans were made also to other scientific and public libraries needing them for serious work.

In connection with this work Miss Barnett inaugurated a new and pioneering service, called the bibliofilm service. Its purpose was to make microfilm copies of articles to send to out-of-town borrowers instead of lending bound volumes. For some time photostat copies had been used for this purpose, but the microfilms were even more useful, especially for long articles.

Miss Barnett was a prominent member of the American Library Association, and in addition to serving as second vice-president in 1921-22 she was chairman of its Oberly Memorial Fund Committee and a member of its Board of Resources of American Libraries. She was an elected member of the American Library Institute. She was active in library circles in Washington and was president of the District of Columbia Library Association in 1929-30.

The history of agriculture in this country was a subject in which she was much interested. She was a charter member of the Agricultural History Society and served as a member of the committee which organized the Washington section in the early 1920's. For its journal, *Agricultural History*, she wrote an article entitled "The Agricultural Museum, an Early Agricultural Periodi-

cal," which appeared in April, 1928. As a matter of interest to herself she did much research on the lives and personalities of the early United States officials in charge of agricultural work before the Department was established and corresponded with their descendants to get information about them. Among these were Henry L. Ellsworth (1791-1858) and Horace Capron (1804-1885). She contributed 25 biographies of agriculturists, including Secretary James Wilson, "Tama Jim," to the "Dictionary of American Biography."

She was a member of the Library Advisory Wage Committee of the U. S. Joint Congressional Committee on Reclassification of Salaries in 1919-20. She was a member of the Washington Academy of Sciences, a fellow of the American Association for the Advancement of Science and the Bibliographical Society of America, and a member of the American Association of University Women, Phi Beta Kappa, and Pi Gamma Mu honorary society.

As a librarian, Miss Barnett's principal aim was to give all possible service to the users of the library, especially to the scientific workers of the Department of Agriculture, and also to those of other institutions, foremost among them the State agricultural colleges and experiment stations. Since the library has an international reputation it is visited by many workers from outside Washington and even the United States. These were always welcomed most cordially, and no trouble was spared in giving help in identifying and assembling the publications needed.

One of the fellow members of the Agricultural History Society wrote of Miss Barnett at the time of her retirement in 1940: "Her great service was performed so modestly, so entirely beyond public notice, and was at the very root of the achievements of other workers, that it is impossible to estimate it."

Personally she was modest as to her own abilities and attainments, although firmly maintaining her decisions after she had thought a thing through. She was interested in other people and was well loved by her staff. She had a great capacity for friendship and possessed an unusual number of devoted friends to whom she herself was equally devoted.

The last six years of her life were spent as an invalid following a stroke in 1945, and she died on March 6, 1951. She was buried in her old home town of Kent, Ohio.

EMMA B. HAWKS

## Officers of the Washington Academy of Sciences

*President*.....WALTER RAMBERG, National Bureau of Standards  
*President-elect*.....F. M. SETZLER, U. S. National Museum  
*Secretary*.....F. M. DEFANDORF, National Bureau of Standards  
*Treasurer*.....HOWARD S. RAPPLEYE, U. S. Coast and Geodetic Survey  
*Archivist*.....JOHN A. STEVENSON, Plant Industry Station  
*Custodian and Subscription Manager of Publications*  
 HAROLD A. REHDER, U. S. National Museum

### *Vice-presidents Representing the Affiliated Societies:*

Philosophical Society of Washington.....A. G. MCNISH  
 Anthropological Society of Washington.....WALDO R. WEDEL  
 Biological Society of Washington.....HUGH T. O'NEILL  
 Chemical Society of Washington.....JOHN K. TAYLOR  
 Entomological Society of Washington.....FREDERICK W. POOS  
 National Geographic Society.....ALEXANDER WETMORE  
 Geological Society of Washington.....A. NELSON SAYRE  
 Medical Society of the District of Columbia.....FRED O. COE  
 Columbia Historical Society.....GILBERT GROSVENOR  
 Botanical Society of Washington.....LEE M. HUTCHINS  
 Washington Section, Society of American Foresters.....WILLIAM A. DAYTON  
 Washington Society of Engineers.....CLIFFORD A. BETTS  
 Washington Section, American Institute of Electrical Engineers.....A. H. SCOTT  
 Washington Section, American Society of Mechanical Engineers.....RICHARD S. DILL  
 Helminthological Society of Washington.....L. A. SPINDLER  
 Washington Branch, Society of American Bacteriologists.....ANGUS M. GRIFFIN  
 Washington Post, Society of American Military Engineers.....FLOYD W. HOUGH  
 Washington Section, Institute of Radio Engineers.....HERBERT G. DORSEY  
 District of Columbia Section, American Society of Civil Engineers  
 MARTIN A. MASON  
 District of Columbia Section, Society for Experimental Biology and Medicine  
 N. R. ELLIS

### *Elected Members of the Board of Managers:*

To January 1953.....C. F. W. MUESEBECK, A. T. MCPHERSON  
 To January 1954.....SARA E. BRANHAM, MILTON HARRIS  
 To January 1955.....ROGER G. BATES, W. W. DIEHL

*Board of Managers*.....All the above officers plus the Senior Editor  
*Board of Editors and Associate Editors*.....[See front cover]

*Executive Committee*...WALTER RAMBERG (chairman), F. M. SETZLER, H. S. RAPPLEYE,  
 WILLIAM A. DAYTON, F. M. DEFANDORF

*Committee on Membership*...E. H. WALKER (chairman), M. S. ANDERSON, CLARENCE COT-  
 TAM, R. C. DUNCAN, JOHN FABER, G. T. FAUST, I. B. HANSEN, FRANK KRACEK, D. B.  
 JONES, E. G. REINHARD, REECE I. SAILER, LEO A. SHINN, F. A. SMITH, HEINZ SPECHT,  
 H. M. TRENT, ALFRED WEISSLER

*Committee on Meetings*...H. W. WELLS (chairman), WM. R. CAMPBELL, W. R. CHAP-  
 LINE, D. J. DAVIS, H. G. DORSEY, O. W. TORRESON

*Committee on Monographs* (W. N. FENTON, chairman):  
 To January 1953.....R. W. IMLAY, P. W. OMAN  
 To January 1954.....S. F. BLAKE, F. C. KRACEK  
 To January 1955.....W. N. FENTON, ALAN STONE

*Committee on Awards for Scientific Achievement* (J. R. SWALLEN, general chairman):  
*For Biological Sciences*.....J. R. SWALLEN (chairman), L. M. HUTCHINS,  
 MARGARET PITTMAN, F. W. POOS, L. P. SCHULTZ

*For Engineering Sciences*.....R. C. DUNCAN (chairman), A. C. FIELDNER,  
 WAYNE C. HALL, J. W. MCBURNEY, O. S. READING, H. L. WHITEMORE

*For Physical Sciences*.....L. A. WOOD (chairman), P. H. ABELSON,  
 F. S. DAFT, GEORGE W. IRVING, JR., J. H. McMILLEN

*For Teaching of Science*.....M. A. MASON (chairman), F. E. FOX, M. H. MARTIN

*Committee on Grants-in-aid for Research*.....L. E. YOCUM (chairman), H. N. EATON,  
 K. F. HERZFELD

### *Committee on Policy and Planning:*

To January 1953.....W. A. DAYTON (chairman), N. R. SMITH  
 To January 1954.....H. B. COLLINS, JR., W. W. RUBEY  
 To January 1955.....L. W. PARR, F. B. SILSBEE

### *Committee on Encouragement of Science Talent* (A. T. MCPHERSON, chairman):

To January 1953.....A. H. CLARK, F. L. MOHLER  
 To January 1954.....J. M. CALDWELL, W. L. SCHMITT  
 To January 1955.....A. T. MCPHERSON, W. T. READ

*Representative on Council of A. A. A. S.*.....F. M. SETZLER

*Committee of Auditors*.....C. L. GAZIN (chairman), LOUISE M. RUSSELL, D. R. TATE

*Committee of Tellers*...GEORGE P. WALTON (chairman), GEORGE H. COONS, C. L. GARNER

## CONTENTS

	Page
SYSTEMATIC ZOOLOGY.—Nomenclature and grammar. CESARE EMILIANI.....	137
ZOOLOGY.— <i>Adercotryma</i> , a new Recent foraminiferal genus from the Arctic. ALFRED R. LOEBLICH, JR., and HELEN TAPPAN.....	141
ZOOLOGY.— <i>Buccella</i> , a new genus of the rotalid Foraminifera. HAROLD V. ANDERSEN.....	143
MAMMALOLOGY.—A new pine mouse ( <i>Pitymys pinetorum carbonarius</i> ) from the southern Appalachian Mountains. CHARLES O. HANDLEY, JR.	152
MALACOLOGY.—Nomenclatural review of genera and subgenera of Chamidae. DAVID NICOL.....	154
ENTOMOLOGY.—A new carpenterworm from Florida (Lepidoptera: Cossidae). J. F. GATES CLARKE.....	156
PALEONTOLOGY.—Two new species of <i>Sinclairiocystis</i> . HARRELL L. STRIMPLE.....	158
BOTANY.—A new <i>Nymphoides</i> from Colombia. LYMAN B. SMITH....	160
PROCEEDINGS: THE ACADEMY.....	161
OBITUARY: Claribel Ruth Barnett.....	167

JOURNAL  
OF THE  
WASHINGTON ACADEMY  
OF SCIENCES

BOARD OF EDITORS

WILLIAM F. FOSHAG  
U. S. NATIONAL MUSEUM

J. P. E. MORRISON  
U. S. NATIONAL MUSEUM

JOHN C. EWERS  
U. S. NATIONAL MUSEUM

ASSOCIATE EDITORS

F. A. CHACE, JR.  
BIOLOGY

MIRIAM L. BOMHARD  
BOTANY

J. I. HOFFMAN  
CHEMISTRY

R. K. COOK  
PHYSICS AND MATHEMATICS

T. P. THAYER  
GEOLOGY

PHILIP DRUCKER  
ANTHROPOLOGY

C. W. SABROSKY  
ENTOMOLOGY

PUBLISHED MONTHLY

BY THE

WASHINGTON ACADEMY OF SCIENCES  
MOUNT ROYAL & GUILFORD AVES.  
BALTIMORE, MARYLAND

Entered as second class matter under the Act of August 24, 1912, at Baltimore, Md.  
Acceptance for mailing at a special rate of postage provided for in the Act of February 28, 1925.  
Authorized February 17, 1949

## Journal of the Washington Academy of Sciences

This JOURNAL, the official organ of the Washington Academy of Sciences, publishes: (1) Short original papers, written or communicated by members of the Academy; (2) proceedings and programs of meetings of the Academy and affiliated societies; (3) notes of events connected with the scientific life of Washington. The JOURNAL is issued monthly. Volumes correspond to calendar years.

*Manuscripts* may be sent to any member of the Board of Editors. It is urgently requested that contributors consult the latest numbers of the JOURNAL and conform their manuscripts to the usage found there as regards arrangement of title, subheads, synonymies, footnotes, tables, bibliography, legends for illustrations, and other matter. Manuscripts should be typewritten, double-spaced, on good paper. Footnotes should be numbered serially in pencil and submitted on a separate sheet. The editors do not assume responsibility for the ideas expressed by the author, nor can they undertake to correct other than obvious minor errors.

*Illustrations* in excess of the equivalent (in cost) of one full-page halftone are to be paid for by the author.

*Proof.*—In order to facilitate prompt publication one proof will generally be sent to authors in or near Washington. It is urged that manuscript be submitted in final form; the editors will exercise due care in seeing that copy is followed.

*Unusual cost* of foreign, mathematical, and tabular material, as well as alterations made in the proof by the author, may be charged to the author.

*Author's Reprints.*—Reprints will be furnished in accordance with the following schedule of prices (approximate):

Copies	4 pp.	8 pp.	12 pp.	16 pp.	20 pp.	Covers
100	\$3.25	\$6.50	\$ 9.75	\$13.00	\$16.25	\$3.00
200	6.50	13.00	19.50	26.00	32.50	6.00
300	9.75	19.50	29.25	39.00	48.75	9.00
400	13.00	26.00	39.00	52.00	65.00	12.00

*Subscriptions* or requests for the purchase of back numbers or volumes of the JOURNAL or the PROCEEDINGS should be sent to HARALD A. REHDER, Custodian and Subscription Manager of Publications, U. S. National Museum, Washington 25, D. C.

*Subscription Rates* for the JOURNAL.—Per year..... \$7.50

Price of back numbers and volumes:	Per Vol.	Per Number
Vol. 1 to vol. 10, incl.—not available*.....	—	—
Vol. 11 to vol. 15, incl. (21 numbers per vol.).....	\$10.00	\$0.70
Vol. 16 to vol. 22, incl. (21 numbers per vol.).....	8.00	0.60
Vol. 23 to current vol. (12 numbers per vol.).....	7.50	0.90

\* Limited number of complete sets of the JOURNAL (vol. 1 to vol. 41, incl.) available for sale to libraries at \$348.50.

MONOGRAPH No. 1, "The Parasitic Cuckoos of Africa," by Herbert Friedmann.	\$4.50
PROCEEDINGS, vols. 1-13 (1899-1911) complete.....	\$25.00
Single volumes, unbound.....	2.00
Single numbers.....	.25

*Missing Numbers* will be replaced without charge provided that claim is made to the Treasurer within 30 days after of following issue.

*Remittances* should be made payable to "Washington Academy of Sciences" and addressed to the Treasurer, H. S. RAPPLEYE, 6712 Fourth Street, N.W., Washington 12, D.C.

*Exchanges.*—The Academy does not exchange its publications for those of other societies.



# JOURNAL OF THE WASHINGTON ACADEMY OF SCIENCES

VOLUME 42

June 1952

No. 6

**BIOCHEMISTRY.**—*Reaction of normal and mutant plastids of Nicotiana to neotetrazolium.* M. W. WOODS, JANE L. SHOWACRE, and H. G. DU BUY,<sup>1</sup> National Microbiological Institute, National Institutes of Health.

Phenyltetrazolium salts are coming into widespread use for the demonstration of sites of subcellular reducing activity, measurement of dehydrogenase activity *in vitro*, etc. (1, 3, 4, 5, 6). Du Buy et al. (2) have reported oxidative enzyme abnormalities associated with isolated mutant mitochondria and plastids of *Nicotiana tabacum* L. The present report describes the intracellular localization of differences in reducing capacity of normal and mutant plastids of *Nicotiana* as demonstrated by reactions to neotetrazolium. The results show that in one and the same cell marked differences occur between normal and mutant plastids.

Free-hand sections of leaf tissues were prepared as previously described (7). Neotetrazolium solution (ca. 0.1 percent) in the nutrient salt-sucrose solution was run under the cover slip. Intact living leaf cells showed little or no reduction of the dye; however, plastids in cells injured in sectioning stained within 2 to 20 minutes. In young leaves ( $\frac{3}{8}$  to  $\frac{1}{2}$  grown) the mutant plastids were pale green without well-defined grana. At this stage the phenolase (tyrosinase) activity (measured colorimetrically in leaf extracts with o-catechol as substrate) of cells with mutant plastids and mitochondria ranged from normal to slightly above normal. In mature leaves this activity was much less than in normal tissues of comparable age. In contrast to this pattern of oxidase (phenolase) activity application of neotetrazolium to leaf sections demonstrated that the mutant plastids had a much lower reducing capacity than normal plastids. This

was true even in leaves too young to show marked diminution in oxidase activity.

Fig. 1, A, shows a living unstained palisade parenchyma cell containing both non-mutant (n) and mutant (m) plastids. Fig. 1, B and C, shows two similar cells killed in sectioning and immediately treated with neotetrazolium. The normal plastids (n), which appear black, have reduced the neotetrazolium to the insoluble purple formazan whereas the mutant plastids (m) are unstained or very slightly stained. The formazan seems to be most concentrated about the grana as can be seen in the cell shown in Fig. 1, C. Note that the nucleus (nucl.) appears unstained.

The present results show that the principal reducing activity of the cell, as measured by neotetrazolium, is localized in the plastids. They support previous data (du-Buy et al. (2)) which showed that in a neoplasm resulting from the appearance of a mitochondrial mutant, the total extent of specific biochemical abnormality is a function of the number of mutant mitochondria present. This is true both with respect to the total number of affected cells as well as within the cytoplasm of a single cell.

## REFERENCES

- (1) BLACK, MAURICE M., AND KLEINER, ISRAEL S. *The use of triphenyltetrazolium chloride for the study of respiration.* Science **110**: 660-661. 1949.
- (2) DU BUY, H. G., WOODS, M. W., AND LACKEY, MARY D. *Enzymatic activities of isolated normal and mutant mitochondria and plastids of higher plants.* Science **111**: 572-574. 1950.
- (3) MATTSON, A. M., JENSEN, C. O., AND DUTCHER, R. H. *Triphenyltetrazolium chloride as a dye for vital tissues.* Science **106**: 294-295. 1947.

<sup>1</sup> Acknowledgment is made to the Department of Botany of the University of Maryland for providing facilities for growing the plants used in these studies.

- (4) NORDMAN, JO., NORDMAN, ROGER, AND NELLE ODETTE GAUCHERY. *Détermination de l'activité deshydrogenasique des mitochondries à l'aide du chlorure de 2,3,5, triphenyl-tetrazolium*. Bull. Soc. Chim. Biol. (In press.)
- (5) STEIN, ROBERT A., AND GERARDE, HORACE W. *Triphenyltetrazolium chloride in tissue culture*. Science **111**: 691-692. 1950.
- (6) STRAUS, FRANCIS H., CHERONIS, NICHOLAS D., AND STRAUS, ELIZABETH. *Demonstration of reducing enzyme systems in neoplasms and living mammalian tissues by triphenyltetrazolium chloride*. Science **108**: 113-115. 1948.
- (7) WOODS, M. W., AND DU BUY, H. G. *The action of mutant chondriogenes and viruses on plant cells with special reference to the plastids*. Amer. Journ. Bot. **38**: 419-434. 1951.

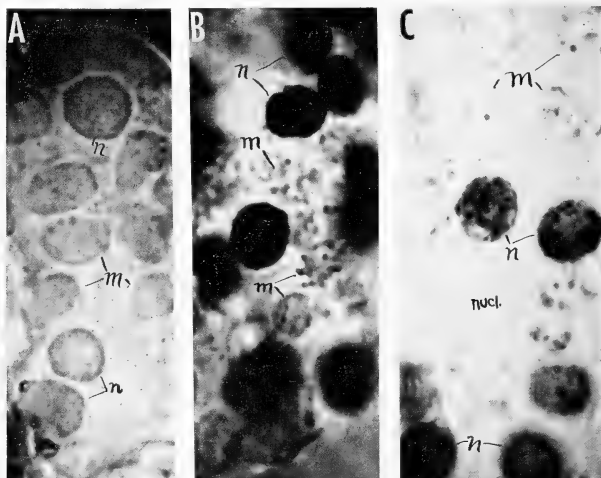

FIG. 1.—*Nicotiana tabacum* L., heterochondric palisade cells,  $\times$ ca.2,000: A, Living unstained cell with mutant (m) and normal (n) plastids; B, heterochondric cell after staining with neotetrazolium, normal plastids (n) colored dark purple, mutant plastids (m) very slightly stained; C, cell similar to B but normal plastids (n) less heavily stained and showing darkening of the grana; nucleus (nucl.) and mutant plastids (m) not stained.

GEOLOGY.—*The base of the Cambrian in the southern Appalachians.*<sup>1</sup> PHILIP B. KING, U. S. Geological Survey.

I must apologize for my presentation this evening in what is primarily a paleontological discussion. What I shall have to say will not be very paleontological but will be concerned largely with physical stratigraphy. I have been dealing with the Lower Cambrian rocks of the southern Appalachians off and on for the past 10 years, but I confess that I have

<sup>1</sup> Presented orally as part of a symposium on "Base of the Cambrian System," held by the Geological Society of Washington, April 11, 1951. Published by permission of the Director, U. S. Geological Survey.

yet to see a good fossil collection from these rocks. Truly, the Lower Cambrian rocks of the southern Appalachians are tough and unrewarding paleontologically.

Let us bear this in mind when we come to the crucial question of the lowest fossiliferous rocks. There is no such thing as a level below which there are no fossils and above which fossils are abundant. Instead, there are rocks below in which no fossils are known, and rocks above in which known fossils are few and far between.

Proponents regarding the base of the Cambrian split three ways—the ultrapaleontological, who would restrict the Cambrian narrowly to actual fossiliferous beds; the ultraphysical, who would extend the Cambrian far downward until a definite, large-scale physical break is encountered; and the middle-grounders, who would look for a lower boundary somewhere in between—more or less where Federal and State surveys conventionally place the boundary today.

I must confess at the outset that I am by predilection a middle-grounder. I have so expressed myself in a paper published several years ago.<sup>2</sup> However, as I discuss the subject with others, I can see that with a little change in viewpoint it is possible to work out favorable arguments for the other two propositions. Consequently, I shall here make my presentation as factual as possible, leaving the reader to draw his own conclusions, if any.

#### SHADY DOLOMITE

In describing the situation in the southern Appalachians, let us begin in the upper part of the sequence, where conclusions are relatively firm, and proceed downward to the area of greater disagreement.

The lowest unit on which there is unanimity is the Shady dolomite, also known in the northeast as the Tomstown dolomite. This is a unit about 1,000 feet thick that comes to the surface at intervals along the southeast side of the Appalachian Valley from Alabama to Pennsylvania and beyond. It forms the base of the great Appalachian Valley carbonate sequence. As in all other Lower Cambrian rocks, fossils are scarce in the Shady formation, but they have been found in enough places—at Austinville, Va., for example—to fix the age of the Shady securely as Lower Cambrian.

#### CHILHOWEE GROUP

From here we pass down into a region of wider disagreement. Below the Shady is a sequence of sandy and shaly rocks known by various local formation names, but for which the general term Chilhowee group is appro-

priate. To fix the Chilhowee group in your minds, remember the fine exposures along the Potomac River where it transects the Blue Ridge at Harpers Ferry. These are made up of quartzites of the Chilhowee group, which separate igneous and metamorphic rocks on the southeast from Paleozoic carbonate rocks on the northwest. Some of you may have noted the composition of the terrace gravels and Potomac River gravels near Washington. Many of the cobbles are quartzite that contains worm tubes, or *Scolithus*. These cobbles are from the Chilhowee group.

The position of the Chilhowee group at Harpers Ferry is maintained for long distances along the strike of the Appalachians. This group lies along the northwest flank of the Blue Ridge from Pennsylvania to Alabama, although it is missing here and there, from faulting or other structural causes.

The Chilhowee has a thickness ranging from 2,500 feet near the Potomac River to 7,000 feet or more in parts of Tennessee. Its top beds are nearly everywhere light-colored indurated quartzose sandstones, or quartzites, but lower down the quartzites are interbedded with much slaty shale or finely laminated siltstone. Downward, also, the sandy beds become less cleanly washed, and the lower sandy beds are rather arkosic and conglomeratic.

In the lower part of the Chilhowee group another lithologic element, lavas and pyroclastic rocks appears rarely. At the base over wide areas in Maryland and northern Virginia is a thin layer of indurated volcanic tuff, accompanied here and there by greenstone flows. In southwestern Virginia, where the group is thicker, there are basalt flows 1,000 feet or more above the base—the amygdaloid of the Unicoi formation. Helium determinations made on the Unicoi amygdaloid indicate that it has an age of about 450 million years. On the assumption that Cambrian time began 500 million years ago, this would place the Chilhowee group safely within the Cambrian. However, we all know that doubt exists in regard to the true age of the base of the Cambrian, as well as in regard to the accuracy of helium determinations.

Pending further radioactive or other physi-

<sup>2</sup> KING, P. B., *The base of the Cambrian in the southern Appalachians*. Amer. Journ. Sci. **247**: 513-530, 622-645. 1949.

cal determinations of age, what do the fossils show? The record of identifiable fossils in the Chilhowee group is scanty. It is true that anyone who maps a Chilhowee outcrop will have no trouble finding worm borings, or *Scolithus* tubes, for these occur by the billions and trillions in the sandstone beds. They are common in the upper quartzite, and they go down to about the middle of the group. These indicate the existence of some form of life during the latter half of Chilhowee time, but they have no value as index fossils. Other fossils, including *Olenellus*, have been found here and there, mainly in the highest beds. I would like to call attention, however, to an apparently authentic occurrence of fossils in the Murray shale near Montvale Springs, on Chilhowee Mountain, Tennessee (King, op. cit., p. 520). These fossils are reported to be at least several hundred feet lower than the others just noted.

Here I should like to make a strong plea for search for more fossils in the Chilhowee group. I have the impression that paleontologists are indifferent to this search. It is true that the fossils are scarce and hard to find, and do not excite much interest biologically when found. But surely the prospect of discovering the oldest remains of life in the Appalachian area should have great appeal. Nevertheless, to my knowledge, only Stose and possibly Butts among recent collectors have reported findings. Practically all the known fossils from the Chilhowee group were obtained more than half a century ago by Walcott and his assistants, within a space of a few years. Revisits to Walcott's old localities by such inexperienced collectors as myself have failed to reveal more. One wonders if the results might not be better if these localities were revisited by more experienced collectors, and if assiduous search in other areas might not lead to the discovery of more localities, more horizons, and more species than those now known.

The contact between the Shady and the Chilhowee is one of the most abrupt in the Appalachians. Below are quartzites, then some shaly transition beds, then dolomite; and this sequence is duplicated in section after section. There is an intriguing possi-

bility that dolomite and quartzite may intergrade along the strike, so that the contact may not everywhere be of the same age. Such relations have been proved by McKee in the Cambrian rocks of the Grand Canyon region. But for the Chilhowee and Shady contact this has never been proved, and where detailed mapping has been done all evidence is against it. For the present, we must reject the suggestion and assume that the Chilhowee-Shady contact is a time line.

What, then, is the history of the Chilhowee group? Beginning with the deposition of coarse waste of ancient lands, with rare volcanic outbursts, we pass upward into shales and more cleanly washed sands. At about mid-point we begin to find evidence of life in the form of worm tubes, and still higher, fossils of more diagnostic character. At the top, clastic deposition gives place abruptly to carbonate deposition. Surely there is little that is very extraordinary about this. It can be duplicated time and time again in transgressive fossiliferous rocks higher in the geologic column. Physical history would seem to link the Chilhowee group firmly with the Lower Cambrian, as its basal transgressive phase, even though a considerable part of its deposits are not fossiliferous.

#### CATOCTIN GREENSTONE

But let us see what is beneath the Chilhowee group, for perhaps this impression is not as secure as it seems at first.

In places the Chilhowee group lies on the eroded surface of ancient plutonic rocks. I have seen such relations near Hampton in northeastern Tennessee and near Shenandoah in northern Virginia. Similar unconformable basal relations are reported elsewhere. Here, the Chilhowee is clearly an initial transgressive deposit. But elsewhere, beds intervene between the Chilhowee group and the ancient plutonic rocks.

Throughout wide areas of the Blue Ridge of northern Virginia the Chilhowee group lies on the Catoctin greenstone, a series of basaltic and andesitic lavas many thousands of feet thick. Continuing downward, we find at the bottom of the Catoctin a thin layer of coarse clastics which, like the basal Chilhowee in other places, lies on the eroded surface of ancient plutonic rocks.

What does this mean? Is this the same unconformity as that at the base of the Chilhowee in other places, and, if the latter is the base of the Cambrian, is this likewise the base of the Cambrian? Or are there two unconformities—one at the base of the Chilhowee on plutonic rocks and Catoctin alike, and another and much older one at the base of the Catoctin? I have expressed a preference for the latter view (King, *op. cit.*, pp. 527-528). In an area in northern Virginia where I studied the relation, the Catoctin wedged out below the Chilhowee, so that in one place the latter rested on the Catoctin, and a few miles away on plutonic rocks. This looked as though the Catoctin was tilted and truncated by erosion before the Chilhowee was laid down over it. Moreover, the thinning of the Chilhowee group from Tennessee into Virginia suggests that there might be a time hiatus between the Catoctin and the Chilhowee.

But geologists who object to this interpretation have pointed out that the thinning of the Catoctin might be due to original wedging out of the mass of flows. Also, the basal bed of the Chilhowee that crosses the truncated edge of the Catoctin is not sandstone or conglomerate but the tuffaceous layer already referred to. So the break, if any, does not lie between Cambrian-like and non-Cambrian-like rocks but within non-Cambrian-like rocks. Moreover, Robert Bloomer has made elaborate chemical and spectrographic determinations on the igneous rocks below and above the supposed break, and he finds no difference between them. Thus, instead of finding a clear-cut physical answer to our problem of the base of the Cambrian, we find only doubt and confusion.

#### OCOEE SERIES

I can not here do justice to a quite different and much more complex set of features and relations farther southwest in the Appalachians—those from the Great Smoky Mountains southwestward into Georgia. In that area there are no volcanic rocks in the section, either in the Chilhowee group or in the beds beneath. The Chilhowee group is flanked on the southeast by high mountains made up of a vast pile of poorly washed clastic sedimentary rocks, the Ocoee series.

I cannot discuss here all the structural complications—of which there are many—or the various conflicting theories that have been proposed. I will say briefly that my own observations indicate that the Chilhowee group lies on the Ocoee series, and that in places the Ocoee series, like the volcanic rocks of the Catoctin lies unconformably on the surface of deeply eroded plutonic rocks.

Is the Ocoee series, then, simply a greatly expanded downward extension of the Cambrian, or is it something distinct? Both Chilhowee and Ocoee are clastic sediments, it is true, but the two are very different in habit. The clastic rocks of the Chilhowee are of the family of quartzite and arkose, whereas those of the Ocoee are of the family of graywacke. Where the contact between them is seen it is abrupt, but we have yet to find evidence for a genuine unconformity. Unconformity or not, there seems to be an abrupt change in sedimentation at the contact, but is this change sufficient to fix the base of the Cambrian above the Ocoee series?

#### BROADER CONSIDERATIONS

I will close with some broader philosophical speculations. Whatever we choose to call Cambrian, it is a fact that in both the Appalachian and Cordilleran geosynclines there are in places below the lowest occurrence of Lower Cambrian fossils vast thicknesses of rocks with no fossils, or with fossils of enigmatic character. These rocks are mainly sedimentary but partly volcanic. They were not materially deformed before Paleozoic time and consequently are the initial geosynclinal deposits. The Canadian geologists tell us that these rocks in the Cordilleran geosyncline of British Columbia—the Belt and Windermere series—are 75,000 feet thick. In the Great Smoky Mountains of Tennessee observations indicate that they are at least 25,000 feet thick, and they may well be thicker.

When were these deposits laid down? I do not believe that it was as long ago as Huronian time. The Huronian rocks are the oldest geosynclinal deposits in the Canadian Shield. After they accumulated and were deformed the shield was permanently consolidated to form the nucleus of the continent. The date of the end of Huronian time is not entirely

clear from the radioactive determinations that have been made. Inconclusive evidence suggests, however, that the interval between the end of the Huronian and the time of the first fossiliferous Cambrian deposits may well have been as long as the whole of Paleozoic time. This would provide ample time for great thicknesses of sediments older than

those containing recognizable Cambrian fossils to accumulate beyond the edges of the Canadian Shield in the primitive Appalachian and Cordilleran geosynclines. Whether we should call these deposits Cambrian and/or Paleozoic, or whether we should begin the Cambrian and/or the Paleozoic higher up, I will leave to the reader.

PALEONTOLOGY.—*A Cretaceous horseshoe crab from Colorado.*<sup>1</sup> J. B. REESIDE, JR., U. S. Geological Survey, and D. V. HARRIS, Colorado Agricultural and Mechanical College.

The living horseshoe crabs are known along the eastern coast of North America from Maine to Honduras and in the coastal waters of southeastern Asia. Many organisms, both terrestrial and aquatic, follow a similar pattern of discontinuous distribution; such a pattern is commonly associated with a long geologic history and a former wide and continuous distribution over the Northern Hemisphere. Though horseshoe crabs are not now living on the coast of Europe, fossil species have been described, mostly under the generic name *Limulus*, from the Triassic, Jurassic, Cretaceous, and middle Tertiary deposits of that continent. The American species, usually called *Limulus polyphemus* (Linnaeus), is one of the most common of the littoral marine invertebrates, so abundant at places that it has been gathered for use as fertilizer. It is surprising, therefore, considering the history of the order and the present abundance of the American horseshoe crab, to find not a single indisputable record of the order from American Mesozoic and Cenozoic deposits. The only suggestion of such an occurrence known to the writers is that of Wheatley (1861), who wrote of a specimen from the Triassic Newark group at Phoenixville, Pa., "*Limulus?* Fragment of shield probably *Limulus*, black bituminous shales," but the record seems very dubious. Paleozoic members of the order, such as *Euproops* and *Paleolimulus* (Clarke, 1913; Shimer and Shrock, 1944), are well known from American formations, but, so far as the writers know, the single specimen here described is the first unquestionable Mesozoic horseshoe crab from this continent.

*Occurrence.*—The specimen, a nearly complete internal impression of an abdominal carapace preserved in a very hard calcareous concretion, was found by Mr. Harris on Fossil Ridge, in the Loveland quadrangle, in the SW $\frac{1}{4}$  sec. 11, T. 6 N., R. 69 W., about 5 miles south of Fort Collins, Larimer County, Colo. The horizon of the specimen is 60 feet above the base of the sandstone member of the Pierre shale that makes Fossil Ridge. There is some difference of opinion as to the name to be applied to the sandstone unit. Five named sandstone members are recognized in the Pierre shale of northeastern Colorado (Ball, 1924; Griffiths, 1949), in upward order, the Hygiene, Terry, Rocky Ridge, Larimer, and Richards members. Some of the earlier workers thought that the Fossil Ridge locality belonged to the Larimer member (Mather et al., 1928), but later opinion assigns it chiefly to the Rocky Ridge member (Griffiths, 1949). Its position is about 5,000 feet stratigraphically below the top of the Pierre shale and about 2,000 feet stratigraphically above the base; these figures are somewhat uncertain because of the difficult conditions of measurement.

*Associated fossils.*—Fossil collecting at Fossil Ridge dates back to the earliest days of geologic investigation in the region, and the fauna recorded there is abundant and varied. Henderson (1908, 1920) listed about 50 species, mostly mollusks, and Griffiths (1949) has essentially repeated his list. Fossil wood in carbonized form is common, but repeated search has disclosed only the single specimen of horseshoe crab. It is notable that the locality yields species that are not known elsewhere in the Western Interior

<sup>1</sup> Publication authorized by the Director, U. S. Geological Survey.

but are found in the Cretaceous of the Gulf Coastal Plain or are represented there by closely related species, for example, *Ostrea fa'cata* Morton, *Exogyra costata* Say, *Capulus spangleri* Henderson, and *Anchura haydeni* White. It is also notable that it is the type locality of a number of species, including *Serpula markmani* Henderson, *Heteropora dimissa* (White), *Pinna lakesi* White, *Inoceramus oblongus* Meek, *Anomia raetiformis* Meek, *Laternula doddsi* (Henderson), *Panope berthoudi* White, *Capulus spangleri* Henderson, *Anchura haydeni* White, and *Volutoderma? clatworthyi* Henderson. The species of *Inoceramus*, *Baculites*, and *Acanthoscaphites* serve best to tie the occurrence to other localities in the Western Interior. The horizons in Fossil Ridge are equivalent faunally to the Verendrye and the Virgin Creek members of the typical Pierre shale and most probably to the upper Campanian of the European classification.

*Taxonomy.*—Van der Hoeven (1838) and Pocock (1902), among others, have discussed the living horseshoe crabs, and the following statement has been taken chiefly from their work. Linnaeus in 1758 placed under *Monoculus polyphemus* horseshoe crabs from America and from eastern Asia, but in 1764 he definitely used the name with a description of the American form. Gronovius in 1764 proposed to use *Xiphosura* for Linnaeus's species, citing it by reference and number, though not by name, and Brünnich in 1771, Scopoli in 1777, and Meuschen in 1778 adopted *Xiphosura* for the genus. Müller in 1785 ignored Gronovius' name and proposed *Limulus* for the species *gigas*, including under that name both American and Asiatic forms. Fabricius in 1793 restricted *Limulus* to the genus typified by the species *gigas*, for which he used, however, the name *polyphemus*, and proposed the name *cyclops* for another form, probably including the American species. Lamarck in 1801 proposed *Polyphemus* as a generic name for Linnaeus' species, separating the Asiatic species as *gigas* and naming the American species *occidentalis*. Latreille in 1802 proposed to use *Xiphosura* as the name for the order containing the horseshoe crabs, retained *Limulus* for the generic name, and distinguished under it four species, restricting the name *polyphemus* to the American form. Leach in 1814 proposed the name *Limulus sowerbii* for the American species, assuming the name *poly-*

*phemus* to be invalid for it. In 1819 he introduced the generic name *Tachypleus* for one of the Asiatic species, reserving *Limulus* for six other species, including *sowerbii* and an *americanus*. Van der Hoeven in 1838 admitted four species, one American and three Asiatic, under the single generic name *Limulus*. There seem to have been few departures from this practice for six decades. Pocock, however, in 1902 adopted *Xiphosura* Gronovius as the generic name for the American species *polyphemus* Linnaeus; *Tachypleus* Leach for three Asiatic species, *gigas* Müller, *tridentatus* Leach, and a new species *hoeveni*; and proposed the genus *Carcinoscorpius* for the species *rotundicauda* Lamarck. Under these names he placed all the previously named living species. Pocock used the name *Xiphosurae* for the order and proposed the family *Xiphosuridae*, with the subfamily *Xiphosurinae* for *Xiphosura* and the subfamily *Tachypleinae* for *Tachypleus* and *Carcinoscorpius*. Pocock placed "Limulinae" in parentheses after "Xiphosurinae" and was the author of both terms. In 1925 the International Commission on Zoological Nomenclature in Opinion 89 (Stiles, pp. 27-33) rejected Gronovius (1764) as a source of systematic names, and in 1928 in Opinion 104 (Stiles, pp. 25-28) it placed the name *Limulus* on the Official List of genera, with "*polyphemus* Linn., 1758a" (sic), as the type species. In decisions announced in June 1950 the Commission formally declared the work of Meuschen (1778) unavailable (Hemming, p. 502) and the generic names of Brünnich (1771) available for nomenclature (Hemming, pp. 307-315). This would have the effect of reinstating *Xiphosura* as of Brünnich as the authorized generic name for the American horseshoe crab, but the Commission directed the Secretary to prepare a report, with recommendations, as to "whether the name *Limulus* Müller, 1785, erroneously placed on the 'Official List of Generic Names in Zoology' by Opinion 104 should be validated . . . or removed from the 'Official List.'" No evaluation has been made of Scopoli's use in 1777 of *Xiphosura*, and at this date (January 1952) the matter is still under discussion. Most zoologists before and since Pocock's contribution have used *Limulidae* for the family and *Limulus* for the American species (e.g., Parker and Haswell, 1949), and paleontologists have used *Limulus* almost exclusively for the Meso-

zoic and Tertiary species (e.g., Zittel, 1885; Clarke, 1913; Shimer and Shrock, 1944). The writers have somewhat reluctantly used *Limulus* rather than *Xiphosura*.

Most of the features necessary for generic assignment—the character of the appendages of the cephalothorax (prosoma) and of the abdomen (opisthosoma), the form of the movable spines along the side of the abdomen, the form of the cross section of the telson—are missing in the fossil specimen here described. The proportions of the abdomen may be observed, however, and are believed to permit distinction between the subfamilies recognized by Pocock.

Pocock (1902, p. 260) cites for his subfamily Xiphosurinae (= Limulinae) the following characters of the abdomen (opisthosoma):

*Opisthosoma* more vaulted, not so markedly hexagonal, owing to lesser prominence of the lateral angle, which lies well in advance of the middle of the lateral border, making the spiniferous edge much longer than the part of the border that has no movable spines; the latter abruptly bent downwards in the posterior two thirds of its length, the spike that it bears lying in front of its middle and much nearer to the 'waist' than to the spike preceding the first movable spine; posterior prolongation of opisthosoma more prominent, the inner edge straight and cutting the outer at an acute angle. . . .

*Lateral movable spines* of opisthosoma alike in both sexes, becoming progressively shorter from before backwards, and gradually tapering from base to apex.

Pocock distinguishes for his subfamily Tachypleinae the following characters of the abdomen (opisthosoma):

*Opisthosoma* less vaulted, more markedly hexagonal owing to the greater prominence of the lateral angle which lies near the middle of the lateral border, making its spiniferous and non-spiniferous parts subequal; the latter not so abruptly bent downwards posteriorly, the area behind its spike, which lies, if anything, farther from the waist than from the lateral angle, subparallel to the area in front of it; posterior prolongations of opisthosoma less prominent, their inner edge convex and cutting the outer at a right angle in the adult. . . .

*Lateral movable spines* on opisthosoma in female short, abruptly narrowed and pointed at apex, not evenly tapering to a point.

It appears to the writers that the present specimen agrees much more with the characters of the Limulinae than with those of the Tachypleinae, and that no characters present would

separate it from *Limulus*, the sole member of the subfamily Limulinae. It is therefore referred to that genus and for convenience of reference is given a specific name.

Order XIPHOSURA Latreille

Family LIMULIDAE Zittel

Subfamily LIMULINAE Pocock

Genus *Limulus* Müller

*Limulus coffini* Reeside and Harris, n. sp.

Figs. 1-3

This species is represented by the internal impression of the abdominal carapace. No trace of the movable lateral spines or of the telson remains. It is 83 mm long over-all, 88 mm wide, and 30 mm high. The outline is an inverted triangle with the apex truncated and in no way suggests the hexagonal outline of the abdomen of the Tachypleinae. It is relatively high (vaulted), with a sharp median longitudinal ridge. The ridge is 60 mm long, and a blunt spine is indicated at the front end and another 32 mm behind it; there may have been a third at the posterior end, but, if so, it is not clearly shown. Anteriorly in a sharp depression on each side of the median ridge and trending toward the ridge from front to back, is a line of six pits, representing inward projections of the carapace, that mark off the six segments included in the mesosomal part of the abdomen. The anterior part of the flanks of the abdominal carapace are evenly rounded; the posterior part is nearly flat and bears a strong muscle scar, presumably for attachment of the muscles of the telson. Each of the posterior lateral margins bears six subequal indentations that mark the sites of the movable spines. The anterior lateral margins are much shorter than the posterior lateral margins, and on the left side the impression suggests that they were bent down. The posterior prolongations are prominent, with the inner edge straight and meeting the outer edge in an acute angle.

The general character of the abdominal carapace indicated by the specimen is much like that of *L. polyphemus* (Linnaeus). It would seem to differ in the more slender spikes separating the indentations of the posterior lateral margins and in the somewhat shorter posterior prolongations.

The specific name is for Prof. R. G. Coffin, Colorado Agricultural and Mechanical College,



Fort Collins, Colo., an assiduous student of the geology of northeastern Colorado. The type specimen is deposited in the U. S. National Museum.

## REFERENCES

- BALL, M. W. *Gas near Fort Collins, Colorado*. Bull. Amer. Assoc. Petrol. Geol. **8**(1): 84. 1924.
- CLARKE, J. M. *Arachnida*. In Zittel-Eastman's "Text-book of Paleontology." London, 1913.
- BEEBE, C. W. *King crab*. The New International Encyclopaedia, ed. 2, **13**: 244-245. 1918.
- BRÜNNICH, Z. T. *Zoologiae fundamenta praelectionibus academicis accommodata*. Copenhagen and Leipzig, 1771.
- FABRICIUS, J. C. *Entomologia systematica emendata et aucta* **2**: 487-488. Copenhagen, 1793.
- GRIFFITTS, M. O. *Zones of Pierre formation of Colorado*. Bull. Amer. Assoc. Petrol. Geol. **33**(12): 2011-2028. 1949.

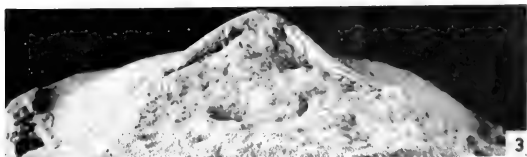
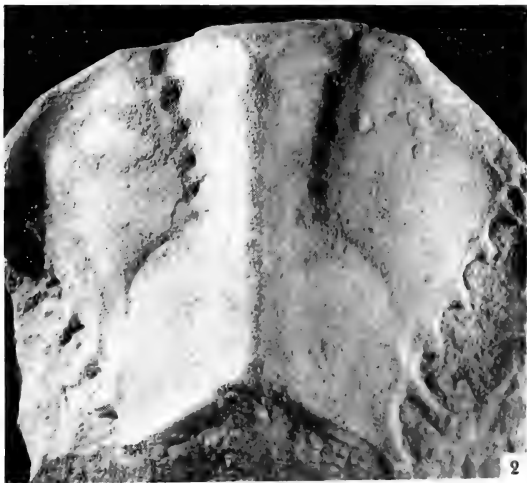
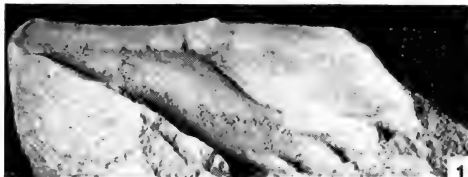

FIGS. 1-3.—*Limulus coffini* Reeside and Harris, n. sp., side, dorsal, and rear views.  $\times 1$ .

- GRONOVIVS, L. F. *Zoophylacium Gronovianum*, etc., fasc. 2, Insecta: 220. Leyden, 1764.
- HEMING, FRANCIS. *The official record of proceedings of the International Commission on Zoological Nomenclature at its session held in Paris in July 1948*. Bull. Zool. Nomencl. 4, June 9, 1950.  
*Conclusions of twelfth meeting*, pp. 307-315.  
*Conclusions of fourteenth meeting*, p. 502.
- HENDERSON, JUNIUS. *The sandstone of Fossil Ridge in northern Colorado and its fauna*. Colorado Univ. Stud. 5: 179-192. 1908.
- . *The Cretaceous formations of northeastern Colorado*. Colorado Geol. Survey Bull. 19: 31-32. 1920.
- LAMARCK, J. B. *Système des animaux sans vertèbres*, etc. 1: 168. Paris, 1801.
- LATREILLE, P. A. *Histoire naturelle générale et particulière des crustacés et des insectes*, etc. Paris, 1802.
- LEACH, W. E. *The zoological miscellany*, etc.: 84. London, 1814.
- . *Dictionnaire des sciences naturelles* 14: 537-538. Paris, 1819.
- LINNAEUS, CAROLUS. *Systema naturae*, ed. 10: 634. Stockholm, 1758.
- . *Museum S. R. M. Ludovicae Ulrica Reginae*, etc.: 460. Stockholm, 1764.
- LOCHHEAD, J. H., in F. A. BROWN, JR., ed. *Selected invertebrate types*: 31. New York, 1950.
- MATHER, K. F., GILLULY, JAMES, AND LUSK, R. G. *Geology and oil and gas prospects of northeastern Colorado*. U. S. Geol. Surv. Bull. 796-B: 89. 1928.
- MEUSCHEN, F. C. *Museum Gronovianum*, etc.: 83. Leyden, 1778.
- MÜLLER, O. F. *Entomostraca seu insecta testacea*, etc.: 124-126. Leipzig and Copenhagen, 1785.
- PARKER, T. J., AND HASWELL, W. A. *A text-book of zoology*, ed. 6, 1: 514. London, 1949.
- POCOCK, R. I. *The taxonomy of Recent species of Limulus*. Ann. Mag. Nat. Hist., ser. 7, 9(42): 256-266. 1902.
- SCOPOLI, J. A. *Introductio ad historiam naturalem*: 405. Prague, 1777.
- SHIMER, H. W., AND SHROCK, R. R. *Index fossils of North America: 705-707*. New York, 1944.
- STILES, C. W. *Opinions rendered by the International Commission on Zoological Nomenclature*. Smithsonian Misc. Coll. 73.  
*Opinions 82 to 90*, no. 3 (Publ. 2830). Dec. 16, 1925.  
*Opinions 98 to 104*, no. 5 (Publ. 2973). Sept. 19, 1928.
- VAN DER HOEVEN, JAN. *Recherches sur l'histoire naturelle et l'anatomie des limules*. Leyden, 1838.
- WHEATLEY, C. M. *Remarks on the Mesozoic red sandstone of the Atlantic slope and notice of the discovery of a bone bed therein at Phoenixville, Pa.* Amer. Journ. Sci., ser. 2, 32: 43. 1861.
- ZITTEL, K. A. *Handbuch der Palaeontologie*. Abt. 1: Palaeozoologie. 2: 643-645. 1885.

BOTANY.—*New mosses from southern Brazil*. EDWIN B. BARTRAM, Bushkill, Pa.

At intervals during the past 15 years I have been receiving carefully selected and beautifully prepared specimens of mosses from Señor Aloysio Sehnem, Colegio S. Inacio, São Salvador, collected in various parts of the Brazilian states of Santa Catarina and Rio Grande do Sul. These have been nicely supplemented by less extensive collection made by Señor P. Raulino Reitz, Herbario Barbosa Rodrigues, Itajai, from the same general area. The total number of species represented is well over 250 distributed in about 120 genera. Preparatory to publishing a complete list of the collections from this interesting temperate region, it seems advisable to describe the following 18 new species that appear in the series. The types of the new species are in the author's herbarium.

FISSIDENTACEAE

*Fissidens (Heterocaulon) sehnemii* Bartr.,  
 sp. nov.

Dioicus; pusillus, dense caespitosus, viridibus.

Caulis erectus, simplex, fertilis brevissimus, sterilis usque ad 3 mm altus; folia plantae sterilis ad 14 juga, late patentia, infima minuta, superiora sensim majora, late ovata, acuta, usque ad 0.4 mm longa/et 0.15 mm lata, integra, lamina vera tantum limbata, prope apicem folii producta, lamina dorsalis longe ultra basin folii enata, basi attenuata; costa infra apicem folii evanida; cellulae ovali-hexagonae, laevissimae, diam. circa 10 $\mu$ . Folia plantae fertilis circa 3 juga, comalia multo majora, e basi ovata longe acuminata; seta 3-3.5 mm longa, rubra; theca erecta, oblongo-cylindrica; operculum oblique conico-rostratum; dentes peristomii ad 200  $\mu$  longi, filiformiter acuminati, superne irregulariter fissi.

Rio Grande do Sul: Estação São Salvador, in terram, alt. 600 m, A. Sehnem no. 2041.

Near *F. antennidens* C. M. as far as one can judge from the description but distinct in the leaf structure, which shows the vaginant lamina produced nearly to the apex of the leaf and indistinctly bordered only in the comal leaves.

## DICRANACEAE

**Campylopus (Eucampylopus) sehnemii**  
Bartr., sp. nov.

Dioicus; robustiusculus, lutescenti-viridis, Caulis erectus, ad 5 cm altus, ubique fusco-tomentosus, dense foliosus. Folia sicca flexuosulo-adpressa, humida erecto-patentia, subequalia, 6-6.5 mm longa, e basi oblonga subulato-acuminata, supra medium serrulata; costa inferne 0.6 mm lata, cellulis ventralibus laxis, dorsalibus stereideis; cellulis laminalibus minutis, rhombeis, basilaribus internis laxe oblongis, parietibus tenuissimis, alaribus haud in ventrem dispositis, internis fuscis, externis hyalinis. Seta circa 8 mm alta, flexuoso-arcuata; theca oblongo-cylindracea, symmetrica; calyptra ignota.

Rio Grande do Sul: Campestre Montenegro, super rupes ad rivum in sole, alt. 400 m, A. Sehnem no. 2310.

A species resembling *C. concolor* (Hook.) Brid. to some extent but with shorter leaves, which are appressed when dry and with different alar cells. In *C. sehnemii* the alar group is poorly defined, brownish within and bordered on the margins with several rows of narrow colorless cells so as to appear intramarginal.

## POTTIACEAE

**Rhamphidium ovale** Bartr., sp. nov.

Dioicum; flos masculus terminalis, gemmiformis. Caulis ad 2 cm altus, gracilis, simplex vel parce ramosus. Folia remota, e basi vaginante subulato-lanceolata, abrupte squarrosopatentia, 2-2.5 mm longa, apice rotundato-obtusa; margines superiores anguste recurvati, indistincte denticulati; costa fusca, percurrens; cellulae superiores subquadratae, inferiores sensim anguste rectangulares, pellucidae. Seta circa 12 mm longa, rubella; theca suberecta, elliptica, deoperculata 1.5 mm longa; operculum oblique tenuiter rostratum, aequilongum; dentes peristomii rubri, ad 350  $\mu$  longi, supra filiformes, dense papilloso, linea media hic illic anguste fissi.

Rio Grande do Sul: Linha Campestre, Montenegro, in declivio argiloso rivi, alt. 450 m, A. Sehnem no. 4999.

Sharply distinct from *R. dicranoides* (C. M.) Bartr. of tropical North America in the ovoid capsules, longer stems and the leaves more abruptly contracted at the shoulders from a longer, tightly clasping base.

**Tortella grossiretis** Bartr., sp. nov.

Tenella, caespitosa, caespitibus sat densis, viridibus. Caulis usque ad 1 cm altus, dense foliosus, simplex. Folia sicca circinato-incurva, humida erecto-patentia, 4-5 mm longa, carinato-concava, e basi oblonga sensim longe et anguste linearia, subulato-acuminata; marginibus erectis, papilloso-crenulatis; costa breviter excurrente; cellulis subrotundis, grosse papilloso, diam. circa 15  $\mu$ , basilaribus hyalinis, rectangularibus, in parte infima laminae limbum angustissimum efformantibus. Caetera ignota.

Rio Grande do Sul: Linha S. Pedro, ad rupem humidam, alt. 450 m, A. Sehnem no. 405.

The relatively large, very coarsely papillose, lamina cells will separate this species from any other member of the genus with which I am familiar. The border of narrow hyaline cells in the upper part of the leaf base is not conspicuous but the structure is typical of the genus.

**Leptodontium fuscescens** Bartr., sp. nov.

Dioicum; sat robustum, caespitosum, caespitibus densis, fusciscenti-viridibus. Caulis ascendens, usque ad 4 cm longus, simplex vel furcatus. Folia sicca flexuoso-adpressa, humida e basi erecta patentia, carinato-concava, 4-5 mm longa, e basi oblonga lanceolata, sensim tenuiter acuminata; marginibus longe ultra medium folii revolutis, superne grosse et irregulariter serratis; costa infra apicem folii evanida; cellulis laminalibus densis, subquadratis, obscuris, haud incrassatis, diam. circa 10  $\mu$ , dense papilloso, basilaribus anguste rectangularibus, parietibus firmis, pellucidis. Caetera ignota.

Rio Grande do Sul: Linha S. Pedro, Montenegro, in humo ad viam, alt. 500 m, A. Sehnem no. 415, type. Pinhal, Montenegro, super rupes in sole, alt. 450 m, A. Sehnem no. 2903.

The more slenderly acuminate leaves with narrower, firmer basal cells will distinguish this species from *L. brasiliense* Mitt. It seems to be more closely allied to *L. subgracile* Ren. & Card. but differs in the more slenderly acuminate leaves with the lamina cells dense and obscure and not at all incrassate.

**Barbula (Helicopogon) riograndensis**  
Bartr., sp. nov.

Dioica; caespitosa, caespitibus densis, fusciscenti-viridibus, opacis. Caulis erectus, ad 2 cm longus, dichotome ramosus, dense foliosus. Folia sicca spiralliter imbricata, humida late

patentia, circa 2.5 mm longa, oblongo-lingulata, obtusiuscula, mucronata; marginibus fere ad apicem late revolutis, integris; cellulis laminalibus minutis, diam. circa  $10\mu$ , obscuris, dense papillosis, basilaribus internis breviter rectangularibus, pellucidis, externis subquadratis; costa in mucronem luteum valde denticulatam excurrente, dorso superne scabro.

Rio Grande do Sul: Quilombo, super rupes, alt. 30 m, A. Sehnem no. 195, type. Pinheiral, Santa Cruz d. Sul, super rupes, alt. 100 m, A. Sehnem no. 2409.

Suggestive of a small *Tortula* in many ways but the costa in cross section showing both dorsal and ventral stereid bands is decisive. The short, yellowish, strongly toothed mucro will distinguish this species from any of the relatively few *Barbula* species known from Brazil.

#### BRYACEAE

##### *Epipterygium brasiliense* Bartr., sp. nov.

*E. immarginato* Mitt. habitu staturaque simile, sed foliis angustioribus, oblongis.

Rio Grande do Sul: Pinheiral, Santa Cruz, ad terram rivulic alt. 100 m., A. Sehnem no. 2350.

The distinctions between this species and *E. immarginatum* Mitt. of Central America are not impressive, but the gap in distribution is so wide that I hesitate to combine them. In *E. brasiliense* the leaves are oblong, about 3 mm long, and 1.1 mm wide, while in *E. immarginatum* the leaves are ovate, about 2.5 mm long, and 1.5 mm wide. The only other species recorded from Brazil is *E. Puiggarii* (Geh. & Hpe.) Broth., a smaller plant with the lateral rows of leaves little differentiated from the dorsal rows.

##### *Bryum* (*Cladodium*) *riograndense* Bartr., sp. nov.

Dioicum; tenellum, caespitosum, caespitibus sat densis, fusciscenti- viridibus. Caulis 8-10 mm altus, inferne fusco-radiculosus, innovationibus pluribus. Folia sicca arcte contorta, humida late patentia, 1-1.5 mm longa, late ovata, obtusa; marginibus inferne leniter revolutis, superne denticulatis, limbata, limbo e seriebus cellularum 3-4 formato; costa infra apicem folii evanida; cellulis teneris, late rhomboideis, circa  $30\mu$  longis. Seta 8-9 mm longa; theca horizontalis, pyriformis, cum collo 2 mm. longa; dentes peristomii c.  $375\mu$  longi, lutei, endosto-

mum liberum, pallidum, processus carinati, perforati, cilia bina, nodosa, haud appendiculata; operculum conicum, obtusum.

Rio Grande do Sul: Santa Cruz, ad rupes in rivo, alt. 80 m, A. Sehnem no. 2347. Estacao São Salvador Montenegro, ad rupes rivuli, alt. 400 m, A. Sehnem no. 2788, type.

A neat, attractive little species evidently near *B. maynense* Spr. but distinct in the more broadly ovate obtuse leaves.

##### *Bryum* (*Eubryum*) *riparioides* Bartr., sp. nov.

Dioicum; caespitosum, caespitibus densis, sorde viridibus. Caulis 6-8 mm altus, inferne denudatus, innovationibus 5-6 mm longis. Folia conferta, sicca laxe imbricata, humida patentia, 2-2.3 mm longa, oblongo-lanceolata, concava, elimbata; marginibus supra medium folii anguste revolutis, superne minute denticulatis; costa crassa, in apicem folii evanida; cellulis ovali-hexagonis, parietibus firmis, infimis subquadratis. Seta 2-2.5 cm longa, rubra; theca pendula, anguste pyriformis, cum collo 3 mm longa; dentes peristomii lutei, endostomium hyalinum, corona basilaris longe ultra medium dentium producta, cilia appendiculata.

Rio Grande do Sul: Vila Oliva, S. Franc. d. Paula, alt. 600 m, A. Sehnem no. 2739, super rupem ad rivum.

A species suggestive of *B. pseudotriquetrum* (Hedw.) Schwaegr. in some ways but quite distinct in the unbordered leaves.

##### *Rhodobryum majus* Bartr., sp. nov.

Habitu *R. glazioviano* sed robustius, olivaceo- viride vel fusciscentis. Folia majora, ad 15 mm longa, 6 mm lata, obovata, breviter acuminata, limbata, limbo valido, superne e 3-4 seriebus cellularum composito, spinoso-serrato; cellulis superioribus ad  $125\mu$  longis. Fructus ignotus.

Rio Grande do Sul: Serra de Rocinha, Bom-jesus, in humo in silva, alt. 1,000 m, A. Sehnem no. 4787.

A more robust plant than *R. glaziovianum* Hpe. with larger leaves spinose-serrate on the upper margins and with much larger upper leaf cells. The lack of reddish color is also noteworthy.

#### ORTHOTRICHACEAE

##### *Orthotrichum* (*Speciosa*) *sehnenii* Bartr., sp. nov.

Antoicum; pusillum, caespitosum, caespitibus densis, pallide viridibus, intus fusciscentibus.

Caulis 5-6 mm. altus, dense foliosus, ramosus. Folia sicca laxa adpressa, leniter contorta, humida late patentia, 2 mm longa, oblongo-ovata, carinato-concava, acuta; marginibus anguste recurvis, integris; costa infra summum apicem evanida; cellulis superioribus rotundatis, incrassatis, papillosis, inferioribus internis breviter rectangularibus. Theca breviter emersa, oblonga, 2 mm longa, stomatibus superficialis, sicca profunde 8-plicata; exostomii dentes sicca reflexi, per paria connati, pallidi, dense minutissime papillosi, processus 8, breviores, laevissimi; spori 12-15 $\mu$ , laeves; calyptra pilosa.

Rio Grande do Sul: Arroio Kruse, in arbore, alt. 10 m, A. Sehnem no. 184.

Possibly near *O. parvum* Herz. of Bolivia, from which it differs in the strongly ribbed capsule, narrower and shorter segments of the endostome, and shorter-pointed leaves.

**Macromitrium nematosum** Bartr., sp. nov.

Caespitosum, caespitibus viridibus, intus atro-fuscescentibus. Caulis repens, ramis erectis, ad 1.5 cm longis, dense foliosis. Folia ramea sicca arcte crispata, humida late patentia, c. 3 mm longa, filis articulatis fuscis, numerosis ornata, oblongo-lanceolata, breviter acuminata vel acuta; marginibus valde undulatis, superne irregulariter dentatis; costa infra summum apicem folii evanida; cellulis laminalibus rotundato-hexagonis, haud incrassatis, diam. c. 10 $\mu$ , basilaribus anguste rectangularibus, parietibus firmis, laevissimis. Caetera ignota.

Rio Grande do Sul: Estação São Salvador, ad arborem in silva, alt. 600 m, A. Sehnem no. 2774.

Unfortunately this collection lacks fruit, so that the species cannot be accurately located, but the numerous brownish septate filaments up to 0.35 mm long, confined principally to the ventral faces of the leaves, is a curious feature without parallel in the genus as far as my experience goes.

**Macromitrium (Leistostoma) perfragile**  
Bartr., sp. nov.

Caespitosum, caespitibus viridibus, intus fuscescentibus. Caulis elongatus, repens, ramis erectis, ad 1.5 cm. longis. Folia ramea sicca crispata, humida patula, anguste lanceolata, 3-3.5 mm. longa, longe subulato-acuminata, apice in cuspidem viridem, fragillimam sensim constricta; marginibus superne minute eroso-

denticulatis; costa in acumen evanida; cellulis minutis, diam. 6-8  $\mu$ , rotundatis, mamillosis, basilaribus linearibus, incrassatis, laevissimis. Caetera ignota.

Rio Grande do Sul: Fazenda S. Borja, S. Leopoldo, in arbore, alt. 50 m, A. Sehnem no. 427. Rio dos Sinos, S. Leopoldo, alt. 10 m, A. Sehnem no. 432. Aparados, Bom Jesús, in arbore, alt. 100 m, A. Sehnem no. 576. Campestre Montenegro, in arbore, at. 450 m, A. Sehnem no. 2175. Vila Oliva, S. Franc. d. Paul, in arbore, alt. 750 m, A. Sehnem no. 2630, type 9.

Possibly near *M. fragilicuspis* Card. of Mexico and Guatemala but distinct in the mamillose lamina cells not in vertical rows and the smooth basal cells.

NECKERACEAE

**Pinnatella brasiliensis** Bartr., sp. nov.

Gracilescens, lutescenti-viridis, opaca. Caulis primarius elongatis, lignosus. Caules secundarii numerosi, lignosi, ad 4 cm longi, stipitati, superne bipinnatim ramosi, stipite ad 2 cm longo, foliis pallidis, obovatis, breviter acuminatis, plerumque destructis instructo; ramis densis late patentibus, sicca apice valde decurvis. Folia caulina late ovata, breviter acuminata, 2 mm longa, 1.2 mm lata; marginibus fere ad basin irregulariter serrulatis; costa crassa, longe ultra medium folii evanida; cellulis superioribus rotundato-hexagonis, diam. 10-15 $\mu$ , laevissimis, infimis linearibus, parietibus pellucidis. Folia ramea et ramulina multo minor, 0.5-0.6 mm longa, orbiculari-ovata, cellulis superioribus incrassatis, vix unipapillosis. Caetera ignota.

Rio Grande do Sul: Estação São Salvador, ad arborem in silva, alt. 600 m, A. Sehnem no. 2772.

When dry the slender branches of the fronds are contracted and strongly decurved at the tips. When moist and relaxed the branches form a dense ovate frond with the pinnae decreasing in length upward. Filiform microphyllous branchlets are produced sparingly in some of the fronds.

HOOKERIAEAE

**Hookeriopsis armata** Bartr., sp. nov.

Synoaica; caespites decumbentes, purpurascens. Caulis repens, parce ramosus, obtusis, complanatus, c. 4 mm latus. Folia conferta, late

patentia, 2 mm longa, oblongo-ovata, breviter acuminata, humida leniter undulata; marginibus planis, superne argute serratis; costis binis, supra medium folii evanidis; cellulae superiores anguste rhomboideae, margines versus angustiores, basilares anguste lineares. Folia perichaetialia minora; seta 10–12 mm longa, rubella, apice arcuato; theca nutans, oblongo-cylindrica, deoperculata 1 mm longa; calyptra pallida, parce pilosa.

Santa Catarina: Armacão do Sul, Ilha de Santa Catarina, ad lignum putridum in silva, alt. 150 m, A. Sehnem no. 3190. Morro do Antão, Ilha de Santa Catarina, ad lignum putridum in silva, alt. 250 m, A. Sehnem no. 3198, type.

The short-pointed leaves coarsely serrate above seem to clearly distinguish this species from either *H. rubens* (C. M.) Broth. or *H. lonchopelma* (C. M.) Broth., which, to judge from the descriptions, are its natural allies.

#### SEMATOPHYLLACEAE

##### *Sematophyllum reitzii* Bartr., sp. nov.

Autoicum; caespites decumbentes, densi, fusciscenti-virides, nitidi. Caulis repens, irregulariter ramosus, ramis ad 2 cm longis, parce ramulosis, saepe cuspidatis. Folia ramea erecto-patentia, conferta, laxe imbricata, oblongo-ovata, breviter acuminata, concava, integra, ecostata, 2 mm longa, 0.8 mm lata; margines erecti; cellulae superiores anguste rhomboideae, inferiores lineares, alares numerosae, auriculatae, fusciscentes, infimae oblongae vesiculosae, supra subquadratae. Seta rubra, c. 15 mm. longa; theca oblonga, horizontalis, deoperculata 1.5 mm. longa.

Santa Catarina: Campo dos Padres, alt., 1,900 m, P. Raulino Reitz no. 2,644.

A well-marked species in the sharply defined auriculate group of alar cells, which are transversely divided so that the lower cells in the group are oblong and the cells above subquadrate.

##### *Sematophyllum riparioides* Bartr., sp. nov.

Autoicum; caespites laxi, laete virides. Caulis repens, parce ramosus. Folia ramea sicca et humida late patentia, oblonga, concava, ecostata, breviter et late acuta, integra, 2.5 mm longa, 0.7–0.8 mm lata; margines erecti; cellulae superiores lineari-rhomboidae, dense chlorophyllosae, inferiores lineares, alares vix vesiculosae, rectangulares, male definitae. Seta rubra, 10–12 mm longa; theca oblonga, horizontalis, deoperculata 1.5 mm longa.

Rio Grande do Sul: S. Francisco de Paula, in terra juxta rivulum, alt. 900 m, A. Sehnem no. 4635.

The numerous transversely divided alar cells suggest some affinity with *S. reitzii* but the distinctions are sharply marked. Here the shorter pointed leaves are laxly spreading when dry and the alar group neither inflated nor conspicuous and not at all auriculate.

##### *Acroporium sehnemii* Bartr., sp. nov.

Autoicum; caespitosum, caespitibus densis, lutescenti-viridibus. Caulis dense ramosus. Folia patentia, 2–2.5 mm longa, e basi oblonga sensim lanceolato-subulata, ecostata; marginibus integris vel superne minutissime denticulatis; cellulis angustissime linearibus, laevissimis, alaribus magnis, oblongis, vesiculososis, fuscis. Folia perichaetialia suberecta, in acumen integrum sensim angustata; seta 5–8 mm longa, rubra, ubique laevissima; theca e collo brevi, elliptica, erecta, vix 1.5 mm longa.

Rio Grande do Sul: Campestre Montenegro, in ramulis arboris viridis ad rivum, A. Sehnem no. 2266, type. Feitoria, alt. 30 m, A. Sehnem no. 106. Santa Catarina: Mata Hoffmann, epifita da mata, alt. 50 m, P. Raulino Reitz no. 3,149.

Sharply distinct from the widely distributed *A. pungens* (Hedw.) Broth. in the autoicous inflorescence, the narrower leaves, and shorter, entirely smooth setae.

ZOOLOGY.—*New western Atlantic records of octocorals (Coelenterata: Anthozoa), with descriptions of three new species.*<sup>1</sup> FREDERICK M. BAYER, U. S. National Museum.

During the course of preparing a résumé of the octocoral fauna of the Gulf of Mexico for the symposium being assembled by Dr. Paul S. Galtsoff, a number of new western Atlantic records of these animals came to light. They materially increase our knowledge of the Gulf octocoral fauna, and also provide more material for determining the origin and relationships of the Gulf fauna. These records, which include stations outside of the Gulf proper as well as within it, are presented in the following list. The bulk of the collection was made by the U. S. Fish Commission steamer *Albatross*, but substantial parts were also contributed by the steamers *Pelican* and *Fish Hawk*, and by the Gulf Expedition of the University of Miami.

Data for the *Albatross* stations cited below are given in a station-list on page 188. All data for other vessels and collectors are in the text.

#### Order TELESTACEA

##### Family TELESTIDAE

#### *Telesto favula* Deichmann, 1936

South of Mobile, Ala., from *Albatross* stations 2387, 2388, 2389, 2390.

#### *Telesto sanguinea* Deichmann, 1936

Off Palm Beach, Fla., 20–30 fathoms, April 1950: m/v *Triton*, Thompson and McGinty. (Previous northernmost record: Carysfort Reef, off Key Largo.)

Off Fort Walton, Fla., 13–14 fathoms, June 3–4, 1947: Frank Lyman.

ESE. of Destin, Fla., 13–14 fathoms, July 29–30, 1948: L. A. Burry and Frank Lyman.

South of Cape St. George, Fla., *Albatross* station 2405.

South of Cape San Blas, Fla., *Albatross* station 2370.

South of Mobile, Ala., *Albatross* station 2387. (Previous northernmost record within the Gulf: west of the Dry Tortugas.)

#### Order ALCYONACEA

##### Family ALCYONIDAE

#### *Nidalia occidentalis* Gray, 1835

63 miles ESE. of Charleston, S. C., *Pelican*

station 195–7: 31° 50.5' N., 79° 26.5' W., 45 fathoms, March 13, 1940.

Off Palm Beach, Fla., 20–40 fathoms, February and April 1950: m/v *Triton*, Thompson and McGinty.

#### Family NEPHTHYIDAE

#### *Eunephtya nigra* (Pourtalès, 1868)

Off Brunswick, Ga., to off Fernandina, Fla., from *Albatross* stations 2415, 2416, 2667, 2668, 2669. (Not previously recorded north of the Florida Keys.)

Off Daytona, Fla., *Albatross* station 2661.

#### *Neospongodes portoricensis* (Hargitt, 1901)

Off Havana, Cuba, from *Albatross* stations 2156, 2160, 2168, 2323, 2333. (Previously recorded only in the West Indies, from Puerto Rico southward and eastward.)

#### Order GORGONACEA

##### Suborder SCLERAXONIA

##### Family BRIAREIDAE

#### *Diodogorgia nodulifera* (Hargitt, 1901)

Off Palm Beach, Fla., 20–60 fathoms, January–April 1950: m/v *Triton*, Thompson and McGinty.

#### *Iciligorgia schrammi* Duchassaing, 1870

Off Palm Beach, Fla., 20–40 fathoms, March, April, and July 1950: m/v *Triton*, Thompson and McGinty.

Triumph Reef, off Elliott Key, Fla., 20–25 fathoms, November 28, 1949: University of Miami Marine Laboratory m/v *Megalopa*, F. M. Bayer.

Off Havana, Cuba, from *Albatross* stations 2157, 2166, 2324, 2334.

##### Suborder HOLAXONIA

##### Family ACANTHOGORGIIDAE

#### *Acanthogorgia aspera* Pourtalès, 1867

Off Fernandina, Fla., *Albatross* station 2415. (Not previously recorded north of Havana.)

##### Family MURICEIDAE

#### *Bebryce cinerea* Deichmann, 1936

Off Cat Cay, Bahamas, 100–150 fathoms.

<sup>1</sup> Published by permission of the Secretary of the Smithsonian Institution. Contribution no. 69 from the Marine Laboratory, University of Miami.

June 1947: Mr. and Mrs. John Wentworth. (Not previously recorded north of the Virgin Islands.)  
Off Havana, Cuba, *Albatross* station 2327.

**Bebryce grandis** Deichmann, 1936

35 miles east of Pass à Loutré, La., *Pelican* station 12: 29° 11' N., 88° 17.5' W., 94.5 fathoms, February 5, 1938.

Arrowsmith Bank, south of Cozumel Island, east coast of Yucatán, *Albatross* station 2354. (Previously recorded from Montserrat and the Barbados.)

**Muricea laxa** Verrill, 1864

Off Havana, Cuba, *Albatross* station 2326.

Off Anclote Keys, Fla., *Fish Hawk* station 7806: Anclote Light E. 1/8 S., 14 miles, 8.5 fathoms, January 11, 1913.

SW. of Cedar Keys, Fla., 28° 42' N., 83° 30' W., 10 fathoms, 1887: Lt. J. F. Moser.

SE. of Jamaica, *Albatross* station 2138: 17° 44' 05" N., 75° 39' 00" W., 23 fathoms, February 29, 1884. (Heretofore recorded from "Florida," the Barbados, and as *M. pendula* Riess not Verrill, from Arrowsmith Bank, Yucatán.)

**Muricea pendula** Verrill, 1868

8 miles W. by N. of Laguna Beach, Fla., 30° 16' N., 86° 04' W., 10 fathoms, October 24, 1948: University of Miami Marine Laboratory Gulf Explorations, J. Q. Tierney.

South of Marsh Island, La., *Oregon* station 295: 28° 41' N., 91° 49' W., 17.5 fathoms, April 4, 1951.

(Previously recorded only from the type locality: Charleston, S. C. The record given by Riess does not deal with this species but with *M. laxa* Verrill, vide supra.)

**Placogorgia mirabilis** Deichmann, 1936

Arrowsmith Bank, south of Cozumel Island, east coast of Yucatán, *Albatross* station 2354. (Previously known only from the type locality: Dry Tortugas, Florida.)

**Scleracis guadalupensis** (Duchassaing and Michelotti, 1860)

Off Palm Beach, Fla., 10?–40 fathoms, May, August 1950: m/v *Triton*, Thompson and McGinty (2 lots). (Not previously recorded north of the Florida keys.)

SSE. of Mobile, Ala., *Pelican* station 136–5, between 29° 38' N., 87° 39' W. and 29° 30' N.,

87° 32.5' W., 21–45 fathoms, March 1, 1939. (Previous northernmost record in the Gulf: NW. of Dry Tortugas.)

**Swiftia casta** (Verrill, 1883)

SSW. of Marsh Island, La., *Pelican* station 94–1: 28° 27' N., 92° 14' W., 29 fathoms, November 13, 1938. (Not previously recorded from the northern Gulf.)

**Swiftia exserta** (Ellis and Solander, 1786)

Off Fernandina, Fla., *Albatross* station 2666.

Off Palm Beach, Fla., 30–40 fathoms, August 1950: m/v *Triton*, Thompson and McGinty.

Off Triumph Reef, Elliott Key, Fla., 20–25 fathoms, November 28, 1949: University of Miami Marine Laboratory m/v *Megalopa*, F. M. Bayer.

Tongue of the Ocean, off Green Cay, Bahamas, *Albatross* station 2651.

SSE. of Mobile, Ala., *Pelican* station 136–4: 29° 38' N., 87° 39' W., 21 fathoms, March 1, 1939. (Not previously recorded from the northern Gulf.)

**Swiftia koreni** (Wright and Studer, 1889)

Off Fernandina, Fla., *Albatross* station 2415. (Apparently not before recorded so far north in the western Atlantic.)

**Thesea plana** Deichmann, 1936

8 miles W. by N. of Laguna Beach, Fla., 30° 16' N., 86° 04' W., 10 fathoms, October 24, 1948: University of Miami Marine Laboratory Gulf Explorations, J. Q. Tierney.

South of Galveston Tex., *Oregon* station 537: 28° 06.2' N., 99° 44.6' W. 30 fathoms, April 15, 1952.

Family PLEXAURIDAE

**Unicea succinea** (Pallas, 1766)

Off NW. end of St. Martins Reef, Florida Banks (south of Cedar Keys), 28° 50' N., 83° W., 1887: Lt. J. F. Moser.

**Plexaura dubia** Kölliker, 1864

14 miles west of Cape Romano (Florida) whistle buoy 16, 25° 40' N., 81° 55' W., 7½ fathoms, September 28, 1948: University of Miami Marine Laboratory Gulf Explorations, J. Q. Tierney.



**Plexaura porosa** (P. L. S. Müller, 1775)

10 miles NW. by N. of New Pass (Florida) buoy, 27° 25' N., 82° 45' W., 5.5 fathoms, September 24, 1948: University of Miami Marine Laboratory Gulf Explorations, J. Q. Tierney.

**Plexaurella kunzei** Kükenthal, 1924

14 miles west of Cape Romano (Florida) whistle buoy 16, 25° 40' N., 81° 55' W., 7½ fathoms, September 28, 1948: University of Miami Marine Laboratory Gulf Explorations, J. Q. Tierney.

## Family GORGONIIDAE

**Antillogorgia acerosa** (Pallas, 1766)

NW. of Charlotte Harbor, Fla., *Fish Hawk* station 7796: Boca Grande Light NNE. ¾ E., 24.5 miles, to NE. ¼ W., 20 miles, 7 fathoms, January 2, 1913.

Southeast of Arcas Keys, Gulf of Campeche, *Oregon* station 436: 20° 07' N., 91° 41.2' W., 20 fathoms, August 24, 1951.

**Antillogorgia americana** (Gmelin, 1791)

9 miles west of Big Marco Pass (Florida), 25° 58' N., 81° 55' W., 6.5 fathoms, September 26, 1948: University of Miami Marine Laboratory Gulf Explorations, J. Q. Tierney.

**Pterogorgia anceps** (Pallas, 1766)

Clearwater Bay, Fla., February 1879: C. A. and J. S. Watson.

**Pterogorgia guadalupensis** Duchassaing and Michelin, 1846

4 miles SW. by S. of Smith Shoal (Florida) Light: 24° 41' N., 81° 58' W., 7½ fathoms, September 29, 1948, University of Miami Marine Laboratory Gulf Explorations, J. Q. Tierney.

Genus **Leptogorgia** H. Milne Edwards, 1857

This genus is characterized among the gorgoniids by the absence (1) of specialized types of spicules and (2) of specialized modes of branching; e.g., reticulate, alate, or lamellate, and therefore is least divergent from what is considered the primitive condition. At least four species in the western Atlantic belong to this genus, two of which (*L. hebes*, *L. miniata*) have been found in the Gulf of Mexico. One species usually referred to *Leptogorgia*, namely *Gorgonia virgulata* Lamarck, regularly has spicules modified into disk spindles like those of the genus *Eugorgia* Verrill, heretofore not recorded from the Atlantic Ocean; and another, *G. setacea* Pallas, has less

modified but still highly atypical sclerites. Although one obvious conclusion might be that *Eugorgia* should not be maintained separate from *Leptogorgia*, it seems preferable at this time to retain both genera, referring *G. virgulata* Lamarck to *Eugorgia*, and *G. setacea* Pallas tentatively to *Leptogorgia*. It is quite possible that in the future a new subgenus of *Eugorgia* will be required for the Atlantic forms, or even that all will be united as subgenera of *Leptogorgia*.

**Leptogorgia hebes** Verrill, 1869

3.5 miles SW. of Longboat Pass, Sarasota, Fla., 5–6 fathoms, March 24, 1951: J. Brookes Knight. Matagorda, Tex.: John Q. Kain.

**Leptogorgia miniata** (Valenciennes, 1855)

Off Palm Beach, Fla., 20–40 fathoms, July 22 and 28, 1950: m/v *Triton*, Thompson and McGinty.

Genus **Eugorgia** Verrill, 1868

The species long known as *Leptogorgia virgulata* (Lamarck) is transferred to Verrill's genus on the basis of its spindles with fused, disklike belts of warts. Three new western Atlantic species are added to the genus.

Spicules of *E. ampla* Verrill, the type species, are shown in Fig. 1, *a-c*, for comparison.

**Eugorgia virgulata** (Lamarck, 1815), n. comb.Fig. 1, *d-i*

10 miles NW. by N. of New Pass (Florida) buoy, 27° 25' N., 82° 45' W., 5.5 fathoms, September 24, 1948: University of Miami Marine Laboratory Gulf Explorations, J. Q. Tierney.

9 miles NE. by N. of Ochlockonee Shoal (Florida) bell buoy, 29° 59' N, 84° 05' W., 3.5 fathoms, October 27, 1948: University of Miami Marine Laboratory Gulf Explorations, J. Q. Tierney.

8 miles W. by N. of Laguna Beach, Fla., 30° 16' N., 86° 04' W., 10 fathoms, October 24, 1948: University of Miami Laboratory Gulf Explorations, J. Q. Tierney.

South of Marsh Island, La., *Oregon* station 295: 28° 41' N., 91° 49' W., 17.5 fathoms, April 4, 1951.

*Remarks.*—Most of the blunt spindles have their warts fused to form thick disks, as illustrated in Fig. 1, *d-g*; long, simple spindles, often with the warts of one side higher and conical (Fig. 1, *h, i*) are also present, in larger numbers

near the twig tips than lower down on the colony. There is no polyp armature regularly present, but some flat, typically "gorgoniid" rods are sometimes found.

Through the kindness of Dr. Gilbert Ranson, of the Muséum National d'Histoire Naturelle, Paris, I have examined spicules from a fragment of Lamarck's type, which agree well with those of the specimens recorded above.

*Range*.—Jamaica? Gulf of Mexico to New York; not at present known from the east coast of Florida.

***Eugorgia stheno*, n. sp.**

Fig. 1, *j-n*

Off Palm Beach, Fla., 30–40 fathoms, July 28, 1950; m/v *Triton*, Thompson and McGinty.

Off Government Cut, Miami, Fla., 40 fathoms, January 24, 1951; University of Miami Marine Laboratory: U.S.A. m/v T-19, F. M. Bayer.

South of Mobile, Ala., *Albatross* station 2387: 29° 24' 00" N., 88° 04' 00" W., 32 fathoms, March 4, 1885. (Holotype, U.S.N.M. no. 49774; paratypes, nos. 49775, 49776, 49777.)

Also from the following *Albatross* stations in the vicinity: 2388, 2389, 2390.

*Description*.—Colonies normally unattached, unbranched or with only one or two simple branches, with a growing tip at all free ends; rarely attached to small rocks or shells. Length variable, commonly 20 cm; diameter 0.4–0.75 mm, in most cases 0.5–0.6 mm, exclusive of the anthosteles. Stem round or but slightly flattened. Anthosteles bluntly conical, somewhat compressed in the long axis of the colony, 0.5–0.75 mm tall; arranged biserially, a single row on each side of the stem, the individuals alternating more or less regularly; distance between zooids (mouth to mouth) 2.5 to 6 mm. On the sides between the zooid rows there is a weak longitudinal ridge, usually detectable only near the tips of the stem, which marks the path of the longitudinal stem canal beneath it. The anthocodiae are fully retractile but in preserved specimens they may remain exert; beneath each tentacle is an *en chevron* field of flat rods with scalloped edges (Fig. 1, *j*); in the pinnules there are delicate, slightly curved, smooth rods (Fig. 1, *k*). The cortical spiculation consists of short, blunt spindles with the warts more or less fused into disks, many of them perfect disk-spindles (Fig. 1, *l*); and long spindles with the warts of one side taller and partly fused, proportionally more

numerous near the growing tips than in the middle of the colony (Fig. 1, *m*). The axial sheath contains symmetrically sculptured spindles (Fig. 1, *n*). Several color phases occur: (1) uniform cream white or pale yellow; (2) white or yellow with red anthosteles; (3) uniform reddish or pinkish orange. Anthocodial spicules in phases 2 and 3 are usually yellow.

*Remarks*.—*Eugorgia stheno* always has a distinct anthocodial armature, unlike *E. virgulata* and the Pacific species of this genus.

This species was taken in abundance at several stations in the northern Gulf of Mexico; the collections from the lower east coast of Florida consist of only a single specimen each.

***Eugorgia euryale*, n. sp.**

Fig. 1, *o-s*

South of Carrabelle, Fla., *Albatross* station 2407: 28° 47' 30" N., 84° 37' 00" W., 24 fathoms, March 15, 1885. (Holotype, U.S.N.M. no. 49764; paratype, no. 49765.)

*Description*.—Colonies attached (?) or free; similar in general appearance to *E. stheno* but much stouter. The type is an unbranched colony 83.5 cm long which shows no evidence that it was ever attached. Near the tips the stem is about 0.9 mm in diameter, increasing to slightly more than 1.0 mm near the middle. Along the two bare sides of the stem runs a longitudinal ridge or furrow depending upon whether the longitudinal canals are distended or collapsed. Anthosteles conical, about 0.5 mm tall, 2.5 to 3.0 mm apart, near the ends of the colony arranged in a single row on each side of the stem, mostly opposite; toward the middle there is an alternating double row along each side. The anthocodiae are fully retractile but may remain exert in preservation; they have an armature of flat rods (Fig. 1, *o*) arranged obscurely *en chevron* beneath the tentacles and parallel for a short distance on the tentacle bases; in the distal portion of the tentacles only smooth, curved rods are present (Fig. 1, *p*).

The cortical sclerites include disk spindles larger than those of *E. stheno*, sometimes with four median disks instead of the usual two (Fig. 1, *q*); these grade into the long spindles which are largest and most numerous near the ends of the colony. These spicules are somewhat flattened, with the warts of the outside rather smooth, conical, and more or less fused together, while those on the edges and on the inner surface

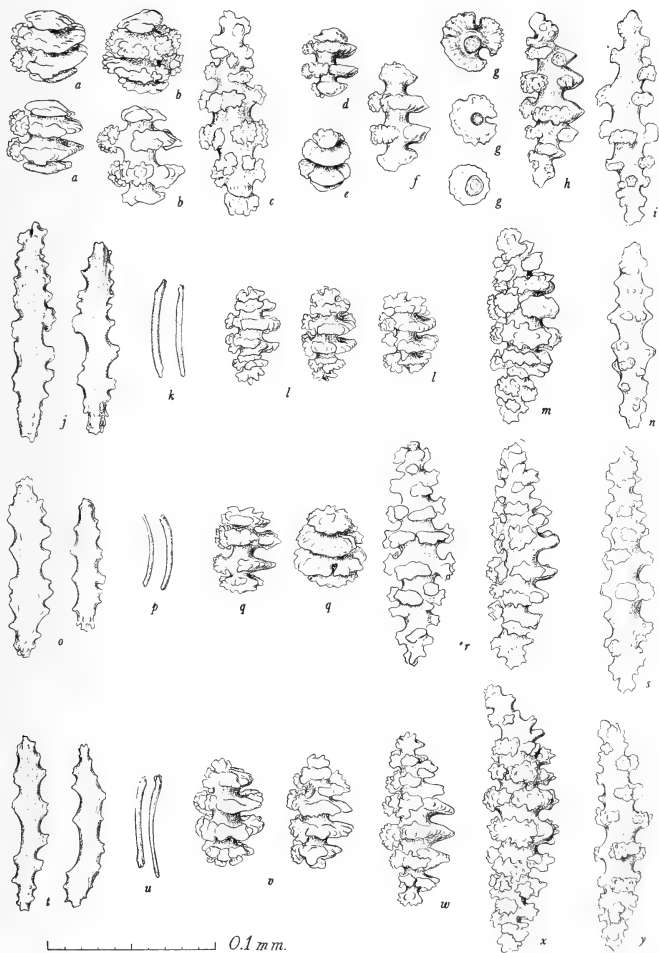

FIG. 1.—a-c, *Eugorgia ampla* Verrill, spicules from a specimen identified by Prof. Verrill: a, Extreme form of disk spindle; b, less strongly developed disk spindles; c, spindle. d-f, *Eugorgia virgulata* (Lamarck): d-f, Disk spindles; g, isolated disks from disk spindles; h, asymmetrical spindle; i, symmetrical spindle. j-n, *Eugorgia stheno*, n. sp.: j, Gorgoniid rods of anthocodiae; k, small rods of anthocodiae; l, disk spindles; m, asymmetrical spindle; n, spindle of axial sheath. o-s, *Eugorgia euryale*, n. sp.: o, Gorgoniid rods of anthocodiae; p, small rods of anthocodiae; q, disk spindles; r, two views of the same asymmetrical spindle; s, spindle of axial sheath. t-y, *Eugorgia medusa*, n. sp.: t, Gorgoniid rods of anthocodiae; u, small rods of anthocodiae; v, disk spindles; w, long disk spindle; x, asymmetrical spindle; y, axial sheath spindle.

are typically complicated (Fig. 1, *r*). Only by viewing these spicules from the edge can this difference between the inner and outer sculpture be seen, and since they are both flattened and bent they do not often present themselves in profile in a preparation. The axial sheath contains spindles with symmetrical belts of low warts (Fig. 1, *s*). The color of the colony is pinkish cream, the calyces red with a yellowish area at the summit.

A paratype is present which was apparently attached at one time although no base is preserved. The angle and curvature of the single branch, and the regeneration of the rind at the proximal end of the main stem suggest that the colony was growing in a recumbent position.

*Remarks.*—Although *E. euryale* is similar in many respects to *E. stheno*, it seems desirable to consider both as species since no connecting intermediates are known by which to unite them.

LIST OF ALBATROSS STATIONS REFERRED TO IN THE ACCOMPANYING TEXT

*Eugorgia medusa*, n. sp.

Fig. 1, *t-y*

Station No.	Lat. N			Leng. W.			Depth fms.	Kind of bottom	Date
	°	'	"	°	'	"			
									1884
2138	17	44	05	75	39	00	23	co. brk. sh.	Feb. 29
2156	23	10	35	82	21	55	278	co.	Apr. 30
2157	23	10	04	82	21	07	29	—	Apr. 30
2160	23	10	31	82	20	37	167	co.	Apr. 30
2166	23	10	36	82	20	30	196	co.	May 1
2168	23	10	36	82	20	20	122	co.	May 1
									1885
2323	23	10	51	82	19	03	163	wh. br. co.	Jan. 17
2324	23	10	25	82	20	24	33	co.	Jan. 17
2326	23	11	45	82	18	54	194	br. co.	Jan. 17
2327	23	11	45	82	17	54	182	fne. br. s.	Jan. 17
2333	23	10	36	82	19	12	169	fne. wh. co.	Jan. 19
2334	23	10	42	82	18	24	67	wh. co.	Jan. 19
2354	20	59	30	86	23	45	130	co.	Jan. 22
2370	29	18	15	85	32	00	25	crs. gy. s. brk. sh.	Feb. 7
2371	29	17	00	85	30	45	26	gy. s. brk. sh.	Feb. 7
2379	28	00	15	87	42	00	1467	yl. oz.	Mar. 2
2384	28	45	00	88	15	30	940	br. gy. m.	Mar. 3
2387	29	24	00	88	04	00	32	s. g. brk. sh.	Mar. 4
2388	29	24	30	88	01	00	35	yl. s. bk. sp.	Mar. 4
2389	29	28	00	87	56	00	27	gy. s. brk. sh.	Mar. 4
2390	29	27	30	87	48	30	30	crs. s. bk. sp. sh.	Mar. 4
2392	28	47	30	87	27	00	724	br. gy. m.	Mar. 13
2394	28	38	30	87	02	00	420	gn. m.	Mar. 13
2397	28	42	00	86	36	00	280	gy. m.	Mar. 14
2400	28	41	00	86	07	00	169	gy. m.	Mar. 14
2405	28	45	00	85	02	00	30	gy. s. brk. co.	Mar. 15
2407	28	47	30	84	37	00	24	co. brk. sh.	Mar. 15
2412	26	18	30	83	08	45	27	fne. gy. s. bk. sp. brk. sh.	Mar. 19
2415	30	44	00	79	26	00	440	co. crs. s. sh. for.	Apr. 1
2416	31	26	00	79	07	00	276	co. brk. sh.	Apr. 1
									1886
2651	24	02	00	77	12	45	97	wh. oz.	Apr. 13
2661	29	16	30	79	36	30	438	gy. s. bk. sp.	May 4
2666	30	47	30	79	49	00	270	gy. s.	May 5
2667	30	53	00	79	42	30	273	gy. s. bk. sp.	May 5
2668	30	58	30	79	38	30	294	gy. s. dd. co.	May 5
2669	31	09	00	79	33	30	352	gy. s. dd. co.	May 5

Abbreviations used in denoting bottom character:

bk. = black	fne. = fine	oz. = ooze
br. = brown	for. = Foraminifera	s. = sand
brk. = broken	g. = gravel	sh. = shells
co. = coral	gn. = green	sp. = specks
crs. = coarse	gy. = gray	wh. = white
dd. = dead	m. = mud	yl. = yellow

ESE. of Boca Grande (Florida) Light, *Albatross* station 2412: 26° 18' 30" N., 83° 08' 45" W., 27 fathoms, March 19, 1885.

South of Carrabelle, Fla. *Albatross* station 2407: 28° 47' 30" N., 84° 37' 00" W., 24 fathoms, March 15, 1885. (Holotype, U.S.N.M. no. 49776; paratype, no. 10464.)

South of Cape San Blas, Fla., *Albatross* station 2371: 29° 17' 00" N., 85° 30' 45" W., 26 fathoms, February 7, 1885.

*Description.*—The type is an unattached stem 44 cm long, bent at almost right angles near the middle where a single branch 18.5 cm long is given off. All three apices show regions of active growth—no base is present. Near the tips the somewhat flattened stem is 1.0–1.5 mm in diameter (exclusive of calyces); the low, rounded, almost contiguous calyces are arranged on either side of the stem in single rows near the apices and in alternating double rows toward the middle of the colony. They are 0.25–0.5 mm tall, 1.0–1.5 mm broad, and 1.5–2.0 mm apart (mouth to mouth); arrangement may be alternate or opposite. The anthocodiae are fully retractile within the anthostoles, and are armed with flat rods (Fig. 1, *t*) below and upon the tentacle bases.

The superficial cortical layer contains numerous well formed disk spindles with two median disks (Fig. 1, *v*), spindles of greater length with 4–6 disks (Fig. 1, *w*), and long, pointed spindles with somewhat asymmetrical sculpture (Fig. 1, *x*). In the inner cortical layer ("axial sheath") there are perfectly symmetrical spindles (Fig. 1, *y*).

In color the colonies are uniform pinkish buff.

*Remarks.*—*Eugorgia medusa* differs from *E. stheno* and *E. euryale* in its more closely set, low calyces, in the form of the disk spindles and the presence of long spindles with 4–6 disks.

## Family GORGONELLIDAE

*Scirpearia funiculina* (Duchassaing and Michelotti, 1864)

South of Mobile, Ala. from *Albatross* stations 2387, 2388, 2389.

## Family CHRYSOGORGIIDAE

*Chrysogorgia elisabethae* F. M. Bayer, 1951

Near Havana, Cuba: Univ. of Iowa Expedition.

*Chrysogorgia elegans* (Verrill, 1883)

Off Cape San Blas, Fla., *Albatross* station 2397.

SE. of Aransas Pass, Tex., *Oregon* station 548: 27° 01.4' N., 96° 16.8' W., 200–280 fathoms, April 18, 1952; and station 549: 26° 58.5' N., 96° 06.7' W., 300–400 fathoms, April 18, 1952.

## Family ISIDIDAE

*Acanella eburnea* (Pourtales, 1868)

South of Apalachicola, west of Tampa, Fla., *Oregon* station 489: 27° 44' N., 85° 09' W., 254 fathoms, September 27, 1951.

From south of Choctawhatchee Bay, Fla., to south of Mobile, Ala., from *Albatross* stations 2384, 2392, 2394, 2397, 2400.

## Order PENNATULACEA

## Family RENILLIDAE

*Renilla mülleri* Kolliker, 1872

6 miles off Pass à Loutre, La., March 13, 1931:

J. C. Pearson.

Corpus Christi, Tex.: C. T. Reed.

## Family FUNICULINIDAE

*Funiculina quadrangularis* (Pallas, 1766)

South of Pensacola, Fla., *Albatross* station 2394.

## Family PROTOPTILIDAE

*Protoptilum* sp. cf. *thomsoni* Kolliker, 1872

South of Mobile, Ala., *Oregon* station 314: 29° 15.5' N., 87° 53' W., 175 fathoms, April 27, 1951.

SE. of Pass à Loutre, La., *Oregon* station 126: 29° 02' N., 88° 34.5' W., 195 fathoms, September 23, 1950.

## Family UMBELLULIDAE

*Umbellula güntheri* Kolliker, 1880

South of Mobile, Ala., *Albatross* station 2379.

## Family VIRGULARIIDAE

*Virgularia mirabilis* (Linnaeus, 1758)

South of Mobile, Ala., *Albatross* station 2387.

Off Galveston, Tex., *Grampus* station 10470: 29° 03' N., 94° 26' W., 9 fathoms, February 28, 1917.

ZOOLOGY.—*New Recent foraminiferal genera from the tropical Pacific.* ALFRED R. LOEBLICH, JR., U. S. National Museum.

The taxonomic portion of this paper is the third of a series resulting from a projected revision of the classification of the smaller Foraminifera. Many species have questionably been placed in well-defined genera and others have been placed in genera that have been so broadly defined as almost to constitute families. This latter procedure has certainly been detrimental to the study of Foraminifera, as students often wonder what system, if any, is followed in such classifications. This was admirably shown by Redmond (1949, p. 19) in a discussion as to what constitutes the genus *Eponides*. Redmond refigured the original illustrations of *Nautilus repandus* Fichtel and Moll, the genotype species of *Eponides*, and also several illustrations by later authors, of specimens that they referred to *Eponides repandus* (Fichtel and Moll). It is clearly evident from these figures that they bear little relation to the genus *Eponides* as defined by Montfort and based on Fichtel

and Moll's *Nautilus repandus*. Furthermore, a search of the literature shows that *Eponides*, as the term is currently used, is a "waste-basket" genus, and so many unrelated forms are included as to make it almost useless as a generic unit. In replying to Redmond's paper, Hofker (1950, p. 15) states, "The difficulty indicated by C. D. Redmond once again indicates the impossibility of observing the rules of nomenclature in dealing with the foraminifera." In a description offered by Hofker (1950, p. 16) he states that the genotype of *Eponides* may be *Eponides repandus* from the coast of Chile or *Eponides frigidus* from North America. To take up the first point by Hofker no easier path to chaos could be followed in a study of the Foraminifera, or for that matter in the study of any group, than to disregard the rules of nomenclature. If any stability is to be maintained in classification, these rules must be adhered to. Otherwise the classification would be subject

to unlimited changes from day to day based on the whims of individual workers. To consider the second point made by Hofker, according to the rules of nomenclature the genotype of *Eponides* can only be *Nautilus repandus* as known to Fichtel and Moll and can not be based on specimens later studied from the coast of Chile. As to *Eponides frigidus* Cushman, cited as a possible genotype by Hofker, the types of this species have never been figured. All figures of this species published by Cushman and others have been in error as none of them agree in character with the cotypes that are in the National Museum collections. Furthermore, this species could not be the genotype species of *Eponides* as it fits neither Montfort's original description of *Eponides* nor the present concept of *Eponides* of the majority of authors. Actually it is more closely related to *Discopulvinulina* Hofker. Hofker has done much to clarify the problems in the Rotaliidae by his clear description of various genera, but it is felt that his solution for the genotype of *Eponides* is in error. What is needed is a restudy of Fichtel and Moll's types or redefinition based on topotype specimens. Should this be impossible, *Eponides* must remain as a genus based on *Nautilus repandus* and the multitude of dissimilar forms referred to *Eponides* should be redescribed and placed in appropriate genera. One such form is here described as a new genus, as it is completely distinct from the type figures and description of *Eponides repandus* and from all other forms referred to *Eponides* by later workers. A second new genus in the family Textulariidae is described as a result from a study of one of the peculiar forms assigned to *Textularia*. This has been another genus to which almost all biserial forms (regardless of apertural char-

acters, wall structure, or other features) have been referred in the past.

Family TEXTULARIIDAE

*Tawitawia* Loeblich, n. gen.

Genotype (type species): *Textularia immensa* Cushman, 1921.

Test large, flattened, biserial; chambers numerous, low, strongly overlapping at the center of the sides; wall coarsely arenaceous, thick, with pillars projecting downward into the interior from the roof of the chambers, giving a labyrinthine interior; aperture terminal, consisting of an elongate series of irregular slits separated completely by pillars across the opening or only partially by projections from one side, aperture does not extend as far as the inner margin of the chamber.

*Remarks.*—This genus differs from *Textularia* Defrance in the labyrinthine interior and the multiple aperture which is terminal in position. It differs from *Cribrostomum* Möller in being flattened and in having a single row of apertures rather than many scattered over the terminal portion of the chamber. It resembles *Polychasmina* Loeblich and Tappan in the apertural character, but is biserial rather than uniserial. *Septigenerina* Keijzer has vertical internal pillars but these are much fewer in number, the test has a coiled base and the aperture is typically textularian. It differs from *Cribrotextularia* Loeblich and Tappan in having a single row of apertural slits, rather than scattered pores over the apertural surface, and in having a labyrinthine interior.

The present genus is monotypic. However, Lalicker and McCulloch (1940, pl. 15, figs. 18d, e, not figs. 18a-c) figured a specimen as *Textularia panamensis* Cushman that very probably belongs to this genus as it shows a similar chamber arrangement with strongly overlapping

FIGS. 1a-c.—*Paumotua terebra* (Cushman): 1a, Dorsal view of holotype (USNM 26160) showing backward curving, raised, and thickened sutures; 1b, ventral view showing more direct sutures, umbilicus, apertural reentrant, and supplementary apertures in line with the aperture, increasing in size as added; 1c, edge view showing low spire and aperture.  $\times 72$ .

FIGS. 2a-5.—*Tawitawia immensa* (Cushman): 2a, Side view of megalospheric hypotype (USNM P. 825c) showing biserial test with final chamber tending to be centrally placed; 2b, top view showing multiple aperture that does not extend to the inner margin of the final chamber,  $\times 15$ ; 3, sectioned hypotype (USNM P. 826) showing biserial character of test and vertical pillars projecting downward from the chamber roof into the cavity,  $\times 33$ ; 4a, side view of microspheric hypotype (USNM P. 825a) showing low and broad biserially arranged and strongly overlapping chambers; 4b, top view showing linear arrangement of the multiple aperture that does not extend to the inner margin of the chamber,  $\times 15$ ; 5, side view of megalospheric hypotype (USNM P. 825b) showing biserial character of test,  $\times 15$ . (All figures camera-lucida drawings by Sally D. Lee, scientific illustrator, Smithsonian Institution.)

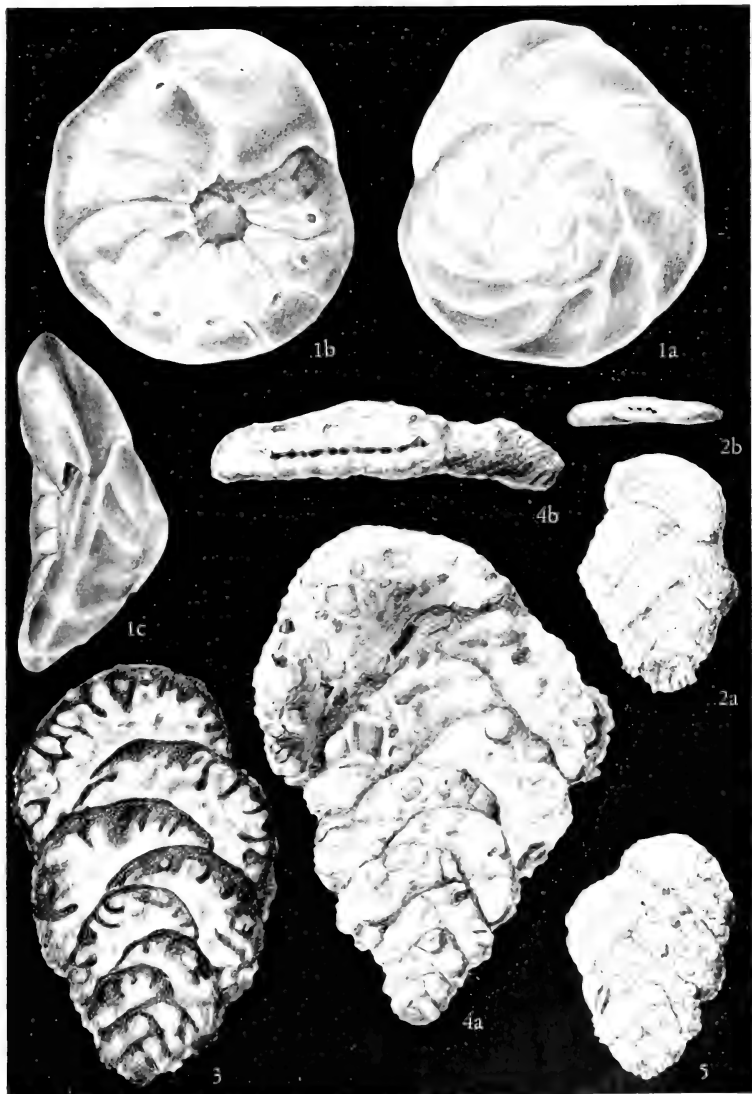

FIGS. 1-5.—(See opposite page for legend.)

chambers and a linear series of apertural slits. However, as there is no evidence as to its internal structure it cannot be referred with certainty to *Tawitawia*. The holotype of *Textularia panamensis* does not show these characters, but is typically textularian.

*Tawitawia immensa* (Cushman)

Figs. 2a-5

*Textularia immensa* Cushman, U. S. Nat. Mus. Bull. 100, vol. 4: 118, pl. 24, figs. 4a, b, 1921.

Test free, large, broad and flattened, rhomboid in outline, quadrate in section, periphery truncate; chambers numerous, low and broad, biserially arranged, and each overlapping the preceding for a considerable distance, final chamber in a few specimens tending to be central in position, chambers flat to slightly depressed centrally; sutures distinct in the later portion of the test, slightly depressed or occasionally left raised on the flat sides of the test by a slight collapse of the chambers, marked by constrictions at the margins of the test, curved and strongly arched upwards; wall coarsely arenaceous, with large grains in a ground mass of finer material, labyrinthic in structure with vertical pillars projecting downward from the chamber roof into the cavity; aperture an elongate closely spaced series of irregular slits, separated by small pillars or projections from the sides, terminal in position on the final chamber.

Length of holotype 6.27 mm, breadth 3.69 mm, thickness 0.57 mm, length of paratype (USNM P. 824) 5.49 mm, breadth 3.07 mm, thickness 0.62 mm. Length of paratype (USNM 12145) 2.44 mm, breadth 1.82 mm, thickness 0.29 mm. Length of hypotype of Fig. 4 (USNM P. 825a) 5.43 mm, breadth 3.80 mm, thickness 0.81 mm, length of hypotype of Fig. 5 (USNM P. 825b) 2.76 mm, breadth 1.90 mm, thickness 0.29 mm. Length of hypotype of Fig. 2 (USNM P. 825c) 2.60 mm, breadth 1.72 mm, thickness 0.31 mm. Length of unfigured hypotypes varies from 2.08 to 5.98 mm.

*Remarks*.—According to the original description (Cushman, 1921, p. 119) this species was based upon two specimens from two localities, and the species was described as rare. A third specimen was labeled as a paratype in his collection but not mentioned in the original description. Examination of material from *Albatross* station D. 5576 (from which the original paratype was recorded) by the present writer has

produced 22 additional specimens which have made possible a more complete description of this species. Cushman stated (1921, p. 118): "... wall thick, of rather coarse angular sand grains imbedded in an unusually large amount of light gray cement," but he apparently did not note its labyrinthic character, which can only be observed in thin sections, and which can be seen in the section shown here as Fig. 3.

In the original description Cushman (1921, p. 118) stated: "... aperture consisting of a series of small openings running from the inner margin of the apertural face to the highest point at the distal end of the test, about 20 in number." However, examination of the holotype, 2 paratypes, and 22 hypotype specimens shows the aperture to be restricted to the terminal portion of the final chamber and does not extend to the inner margin of the chamber.

The labyrinthine walls and the distinctive aperture separate this form from the genus *Textularia*.

*Types and occurrence*.—Holotype (USNM 8502) and paratype (USNM P. 824) from *Albatross* station D. 5567, Dammi Island (N.) N.81°W. 9 miles, lat. 5°48'00" N., long. 120°33'45" E.; from fine sand at 268 fathoms, bottom temperature 52°F. Paratype (USNM 12145), figured hypotypes (USNM P. 825a-c and P. 826), and unfigured hypotypes (USNM P. 827 a-r) all from *Albatross* station D. 5576 north of Tawi Tawi, Mount Dromedario (Tawi Tawi) S.22°W., 17.2 miles; lat. 5°25'56" N., long. 120°03'39" E.; from sand at 277 fathoms, bottom temperature 53.3°F.

Family ROTALIIDAE

*Paumotua* Loeblich, n. gen.

Genotype (type species): *Eponides terebra* Cushman, 1933.

Test free, trochoid, planoconvex, ventral side flattened and umbilicate, dorsal side in a low spire, chambers numerous; wall calcareous, hyaline; aperture a low arch at the front margin of the final chamber, between the periphery and umbilicus on the ventral side, supplementary apertures in a row paralleling the periphery and in line with the main aperture, on the ventral side, consisting of one or more open pores or slits which increase in size and number as chambers increase in size.

*Remarks*.—This genus differs from *Eponides* Montfort in possessing ventral supplementary apertures. *Discopulvinulina* Hofker has ventral



supplementary apertures in the form of an arch along the sutural margin of each chamber. *Pseudoeponides* Uchio has supplementary apertures similar to those of *Discopulvinulina* along the sutural margins, and in addition has slits on the central portion of each chamber, but on the dorsal side. The present genus does not have dorsal supplementary apertures, and the ventral ones are not at the sutural margins, but across the central portion of the chambers.

**Paumotua terebra** (Cushman)

Figs. 1a-c

*Eponides terebra* Cushman, Contr. Cushman Lab. Foram. Res. 9, pt. 4: 89, pl. 10, figs. 1a-c. 1933.

Test free, trochoid, planoconvex to concavoconvex, dorsal side with a low spire, periphery with a rounded keel; all of the  $2\frac{1}{2}$  whorls visible dorsally, only the 8-10 chambers of the final whorl visible ventrally, but these do not reach the center but leave a wide open umbilicus, chambers increasing very gradually in size as added; sutures distinct, curved backward on the dorsal side, raised and thickened, more gradually curved ventrally, and slightly depressed; wall calcareous, hyaline, surface smooth; aperture ventral, forming a reentrant about one-third the distance from the periphery to the umbilicus and one or more rounded to somewhat elongate supplementary apertures on the ventral side in line with the main aperture but away from the apertural margins of the chambers, increasing in size and number as the chambers enlarge, and remaining open throughout.

Greatest diameter of holotype 0.86 mm, least diameter 0.78 mm, height of spire 0.39 mm,

greatest diameter of paratype 0.52 mm, height of spire 0.21 mm. Greatest diameter of hypotype 0.53 mm, height of spire 0.18 mm.

*Remarks.*—Cushman noted the peculiar supplementary apertures in his original description of the species, which was apparently based on the holotype and a single paratype. One additional unlabelled specimen was found in the collection, and all three specimens from two stations show identical development of these supplementary apertures, which could not therefore be accidental. As this feature is not found in *Eponides* Montfort, the present species is regarded as belonging to a distinct genus.

*Types and occurrence.*—Holotype (USNM 26160) from *Albatross* station H. 3931, Anu Anuraro Atoll, southeast  $\frac{1}{2}$  mile, Paumotu Islands, depth 405 fathoms, bottom temperature  $42.5^{\circ}\text{F}$ .; bottom coral sand, pteropod ooze, and manganese particles. Paratype (USNM 26161) and unfigured hypotype (USNM P. 828) from *Albatross* station H. 3910, southwest point Aki Aki, east 1 mile, Paumotu Islands, depth 377 fathoms; bottom temperature  $43.0^{\circ}$ ; bottom coral sand.

REFERENCES

- CUSHMAN, J. A. *Foraminifera of the Philippine and adjacent seas*. U. S. Nat. Mus. Bull. 100, vol. 4: 1-608, pls. 1-100. 1921.
- . *Some new Recent Foraminifera from the tropical Pacific*. Contr. Cushman Lab. Foram. Res. 9: 77-95, pls. 8-11. 1933.
- HOFKER, J. *What is the genus Eponides?* Micropaleontologist 4: 15-16. 1950.
- LALICKER, C. G., AND McCULLOCH, I. *Some Textulariidae of the Pacific Ocean*. Allan Hancock Pacific Exped. 6: 115-143, pls. 13-16. 1940.
- REDMOND, C. D. *What is the genus Eponides?* Micropaleontologist 3: 19-21. 1949.

ZOOLOGY.—*Fresh-water triclads (Turbellaria) of the Rocky Mountain National Park region, Colorado*. ROMAN KENK. (Communicated by Fenner A. Chace, Jr.)

The present paper is a report on the results of a brief investigation of aquatic habitats in the Rocky Mountain National Park region, Colorado. The short time at my disposal, one week, did not permit an intensive coverage of the area studied, and only places accessible by road could be visited. I am indebted to Hillory A. Tolson, John E. Doerr, David H. Canfield, and Ed Alberts, of the National Park Service, for facilitating my field work in Colorado; and to Prof. Edward G. Reinhard, Catholic University,

and Dr. Doris M. Cochran, Smithsonian Institution, for kindly extending to me the use of their laboratory and office facilities in Washington, D. C.

The triclad fauna of Colorado is very little known. Ward (1904: 143) reports that numerous immature, unidentified planarians were present in a bottom haul from Dead Lake, a small water basin south-southeast of Pikes Peak. Cockerell (1927: 242) states that a dark-colored planarian is not rare in mountain springs of Colorado and that, in

1922, *Planaria maculata* [*Dugesia tigrina* (Girard)] and *P. dorocephala* [*Dugesia dorocephala* (Woodworth)] were liberated in the pond on the University of Colorado campus in Boulder. A species from Boulder was identified by Hyman (1931b: 327) as *Phagocata velata* (Stringer). These meager data appear to be the only records of Colorado triclads found in literature.

My collections in the Rocky Mountain National Park region yielded only one triclad species, apparently identical with that observed by Cockerell, *Polycelis coronata*.

***Polycelis coronata* (Girard, 1891)**

A summary of previous literature data on *Polycelis coronata* has been presented by Hyman (1931a). The species was first collected by Joseph Leidy in 1877 and was later described, apparently from Leidy's notes and material, by Girard (1891, 1893) under the name *Phagocata coronata*. Hallez (1894: 179) considered the species to be possibly identical with the European *Polycelis nigra* (O. F. Müller). The correct taxonomic position of the species was established by Hyman (1931a), who furnished a good description of its anatomy and natural history.

The present report aims to supplement Hyman's data and to carry out a comparison of *Polycelis coronata* with another, very similar, species of the same genus occurring on the North American Continent, *P. borealis* (cf. Kenk, in press).

*External characters.*—Mature, quietly gliding specimens measure up to 13 mm in length and up to 1.5 mm in width. Hyman saw many individuals 15 to 20 mm long and considers this to be the maximum length. The anterior end is truncated, with convex frontal margin, and the sides of the head project as a pair of broad, usually pointed auricles (Fig. 1). Hyman, in her figure 1, indicates that the tip of the auricles is rounded; it appears, indeed, that the shape of the auricles varies to some extent according to the physiological state of the animal. Active individuals in lively locomotion show the tips of the auricles more distinctly pointed than do less active animals moving sluggishly. In quiet gliding, the auricles are held lifted obliquely above the substratum. Behind the auricles there is a slight narrowing of the body; posteriorly the width increases gradually until the maximum width is reached in the region of the pharynx; behind the pharynx, the lateral

margins of the body converge again to meet in a bluntly pointed posterior end.

The eyes are numerous and are arranged in a curved zone, more than one row wide, along the frontal margin and the anterior parts of the lateral margins. The zone or band of eyes may be narrowed as it crosses the base of the auricles, as Hyman observed; in some individuals, however, there is no distinct narrowing of the band in that place. Behind the head, the band of eyes tapers to a single row extending backward for about one-fourth to one-third of the prepharyngeal region.

The general color of the dorsal side is usually uniform, grayish brown to almost black. Occasionally one may see an indistinct lighter midline in the prepharyngeal part of the body and a lighter field above the pharynx. The color of the ventral side is lighter.

The pharynx is inserted at, or a short distance behind, the middle of the body. It is of considerable length, measuring from one-sixth to one-fourth the length of the body. The length of the



FIG. 1.—*Polycelis coronata*, sketch of the living animal,  $\times 8$ .

postpharyngeal region varies considerably, particularly in asexual animals. When the animals are in the state of asexual reproductive activity, the postpharyngeal parts of the body may be very short and all stages of regeneration of the posterior region may be seen.

*Polycelis coronata* moves by gliding only. No "crawling" locomotion has been observed.

**Reproductive system.**—The testes occupy two short zones in the prepharyngeal region, one on each side of the anterior intestinal trunk, and are situated on the ventral side as is typical of the genus *Polycelis*.

The copulatory organs (Fig. 2) furnish the best characters distinguishing *Polycelis coronata* from other species of the genus. The genital aperture leads into a small, spherical cavity, the common genital atrium (*ac*), which receives, from the left side, the duct of the copulatory bursa (*bd*) and connects anterodorsally with a wider cavity, the male atrium (*am*). The walls of both atria are lined with a cubical epithelium under which there are two muscular layers, one composed of circular and the other of longitudinal fibers.

The penis consists of a large ellipsoidal bulb and a short broad papilla (*pp*). The penis bulb has a thick wall composed of a meshwork of muscle fibers arranged in concentric layers and running in various directions. This muscular wall is pierced by radial canals containing the outlets of glands emptying into the cavity of the bulb. The secretion of these glands is stained very

slightly with eosin. The voluminous, elongated cavity of the penis bulb, or seminal vesicle (*vs*), is lined with a tall epithelium of glandular nature. In fully mature specimens, the epithelium forms villuslike processes projecting into the vesicle.

The two vasa deferentia, after penetrating the wall of the penis bulb, open into the seminal vesicle near its middle. Frequently, but not in all specimens, the opening of the left vas deferens (*vds*) is at a level posterior to the opening of the right vas deferens (*vdd*).

The lumen of the seminal vesicle continues posteriorly into the wide canal of the short penis papilla. The epithelium of this canal is cubical and nonglandular. The canal could be interpreted as an ejaculatory duct, but is apparently devoid of a proper muscle coat. The outer epithelium of the papilla is cubical, contains only few nuclei (part of the nuclei may be depressed?) and has two underlying muscular layers, a circular one and a longitudinal one.

The two oviducts bend dorsally and medially at the level of the penis bulb and unite at a point posterodorsal to the male atrium. The common oviduct (*odc*), formed by their fusion, proceeds ventrally, curving along the wall of the atrium, and opens into the atrial cavity at the junction of the male and common atria. The terminal portions of the paired oviducts and the common oviduct receive outlets of numerous eosinophilic shell glands.

The copulatory bursa (*b*) is a large, lobed sac situated between the wall of the pharyngeal

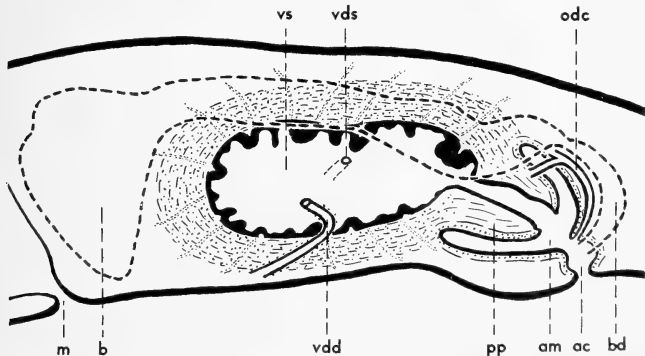

FIG. 2.—*Polycelis coronata*, diagram of the copulatory organs in sagittal section,  $\times 80$ . (*ac*, common atrium; *am*, male atrium; *b*, copulatory bursa; *bd*, bursa stalk; *m*, mouth; *odc*, common oviduct; *pp*, penis papilla; *vdd*, right vas deferens; *vds*, left vas deferens; *vs*, seminal vesicle.)

pouch and the penis bulb. Its dorsal part continues, somewhat to the left of the midline, into a wide duct with irregular outline, which runs posteriorly on the left of the penis. At the level of the male atrium, the structure of the wall changes abruptly. The duct becomes a highly muscular tube (*bd*) running ventrally and opening, from the left side, into the common atrium. The sac of the bursa and the anterior part of its outlet have the same histological structure. The cells of their epithelial lining are large glandular cells; fine muscle fibers, such as are found in other species coating the bursa sac, coat both sections externally, as mentioned by Hyman. It appears, therefore, that the sac and the greater part of the duct correspond to a true bursa and that the bursa stalk is represented by the short muscular terminal part (*bd*) of the duct (called vagina by Hyman). The epithelium lining the terminal section is cubical and ciliated and is marked off sharply from the secretory lining of the anterior section. The thick muscle coat consists of circular and longitudinal fibers.

*Ecology.*—*Polycelis coronata* is a common inhabitant of mountain streams and mountain lakes in the Rocky Mountain National Park region. It was collected in about 50 percent of the suitable localities examined in the area, and its presence may have been overlooked in places where no thorough collections could be made. It is generally found attached to the undersides of stones. The temperatures of the habitats of the species ranged, in the latter part of September, from 4.4° to 10.9°C.

The great majority of the animals collected were asexual. Most of the asexual specimens exhibited regenerating posterior ends or regenerating heads, indicating that asexual reproduction by fission was taking place. The relative proportion between the numbers of individuals in the various reproductive phases was reflected in a collection made in Glacier Creek: of 39 specimens collected, 2 were sexually mature, 20 lacked sex organs but showed signs of recent fission, and 17 were asexual without evidence of reproduction. Hyman (1931a: 124, 131), on the other hand, states that, when she collected the species in South Dakota in the early fall, many of the specimens secured were in full sexual maturity and that there were no indications of the occurrence of fission. It is well known, however, that the same species of freshwater triclads may show

different habits of reproduction in different areas of their occurrence.

*Distribution.*—Girard's (1891, 1893) specimens of *Polycelis coronata* had been collected in a spring near Fort Bridger in southwest Wyoming. Hyman (1931a: 124) found the species in a stream near Deadwood and in a brook near the State Game Lodge, both in the Black Hills, S. Dak. It appears that Hyman later obtained material from additional localities, since, in a recent paper (1951: 162), she indicates the range of the species as "Black Hills of South Dakota to the northwest Pacific coast."

In Colorado, *Polycelis coronata* was collected in clear, fast mountain streams in or near the Rocky Mountain National Park, on both sides of the Continental Divide. It was also taken in a clear mountain lake, Poudre Lake. The habitat altitudes were between 7,000 and 10,700 feet.

Thompson River: (a) East of the town of Estes Park, near junction of highways U. S. 34 and Colorado 66; (b) in Moraine Park, above bridge on Bear Lake Road.

North Fork of Thompson River, 1 mile below Glen Haven (Fig. 3). One specimen, on 4 slides, U. S. N. M. no. 23679.

Glacier Creek (tributary of Thompson River), near Glacier Basin camping ground.

Fall River (tributary of Thompson River), where it enters the town of Estes Park.

Tributaries of Fall River, crossing Fall River Road: Roaring River and Chiquita Creek.

Streams of the St. Vrain Creek basin, crossing highway Colorado 7: North St. Vrain Creek, Willow Creek, Rock Creek, and Middle St. Vrain Creek.

Onahu Creek (tributary of Colorado River), below bridge on highway U. S. 34.

Tonohutu Creek, above its opening into Grand Lake.

Poudre Lake, on Trail Ridge Road (U. S. 34), altitude 10,700 feet, water temperature near shore, 7.3°C. (Fig. 4).

Miss Betty Locker, of the Rocky Mountain Laboratory, Hamilton, Mont., sent me samples of *Polycelis* collected in a cool spring (11°C., May) on Eastmoreland golf course in Portland, Oreg.; and on Skalkaho Pass (east of Hamilton), Ravalli County, Mont. These have been deposited in the U. S. National Museum (nos. 23787, 23788). Though no anatomical study of the specimens could be made, the external characters of the preserved specimens agree with *P. coronata*. The species undoubtedly has a wide distribution in the western states.

*Taxonomic position.*—The absence of adeno-dactyls and of an excessively developed muscle coat of the male genital atrium identifies *Polycelis coronata* as a member of the subgenus *Polycelis* (cf. Kenk, in press). The species has a very close external resemblance to *P. borealis* from Alaska. The two species cannot be distinguished on the basis of external characters alone; moreover, their ecological characteristics are identical, as both inhabit mountain streams and mountain lakes.

The two species are, however, clearly separated by the anatomy of their reproductive systems. *P. coronata* has a large, elongated penis bulb

*Zoogeographical note.*—The genus *Polycelis* is primarily distributed over Europe and Asia where it is represented by a considerable number of species. The two North American species, *P. coronata* and *P. borealis*, are both confined to the western part of the continent, the western United States and Alaska. It appears probable that both species have, in the geological past, entered the continent from Asia, over the Alaskan land bridge (Kenk, in press). The range of distribution of either species is not fully known. Their areas may adjoin, or even overlap, in the Canadian Rockies.

FIG. 3 (below).—North Fork of Thompson River, 1 mile below Glen Haven, Colo. *Polycelis coronata* on the undersides of stones.



FIG. 4 (above).—Poudre Lake, on Trail Ridge Road, Rocky Mountain National Park, Colo. *Polycelis coronata* under stones along shore.

with a spacious seminal vesicle into which the vasa deferentia open from the sides, and a short papilla; in *P. borealis*, the bulb is spherical and less voluminous, the seminal vesicle smaller, the openings of the vasa deferentia anterolateral, and the penis papilla comparatively larger. The copulatory bursa of *P. coronata* has a characteristic feature not seen in other species of the genus: the bursa extends posteriorly, without changing its histological structure, as a duct which connects with a true muscular bursa stalk at the level of the male atrium. In *P. borealis*, as in other species, the entire duct of the bursa is equipped with a thick coat of muscle fibers.

#### LITERATURE CITED

- COCKERELL, THEODORE D. A. *Zoology of Colorado*, vii + 262 pp., illus. Univ. Colorado, Boulder, 1927.
- GIRARD, CHARLES. *Deux espèces nouvelles de planaires américaines*. *Naturaliste* **13**: 80. 1891.
- . *Recherches sur les planariés et les némeritiens de l'Amérique du nord*. *Ann. Sci. Nat. (Paris), Zool.* (7) **15**: 145-310, pls. 3-6. 1893.
- HALLEZ, PAUL. *Catalogue des rhabdocoelides, triclades et polyclades du nord de la France*, ed. 2, 239 pp., 2 pls. Lille, 1894.
- HYMAN, LIBBIE H. *Studies on the morphology, taxonomy, and distribution of North American triclad Turbellaria. III. On Polycelis coronata (Girard)*. *Trans. Amer. Mier. Soc.* **50**: 124-135. 1931.

- IV. *Recent European revisions of the triclads, and their application to American forms, with a key to the latter and new notes on distribution.* Trans. Amer. Micr. Soc. **50**: 316-335. 1931.
- North American triclad *Turbellaria*. XII. *Synopsis of the known species of fresh-water planarians of North America.* Trans. Amer. Micr. Soc. **70**: 154-167. 1951.

- KENK, ROMAN. *The fresh-water triclads (Turbellaria) of Alaska.* Proc. U. S. Nat. Mus. (In press.)
- WARD, HENRY B. *A biological reconnaissance of some elevated lakes in the Sierras and Rockies.* Stud. Zool. Lab. Univ. Nebraska **60**: 127-154, pls. 19-31. 1904.

## PROCEEDINGS OF THE ACADEMY

### 54TH ANNUAL MEETING

The 54th Annual Meeting, concurrently with the 384th monthly meeting of the Academy, was held as a dinner meeting in the ballroom of Hotel 2400 on the evening of January 17, 1952. Vice-President J. J. FAHEY presided.

After the dinner Dr. Fahey called the meeting to order. The minutes of the 53d Annual Meeting were approved as published in the *JOURNAL* **41**: No. 7, 238-244. July 1951.

The Secretary read a letter to the Board of Managers dated January 12 from President Smith, who has retired and is now living in Florida. He expressed his appreciation for the cooperation received from the members of the Academy during his term of office, and proffered his best wishes for a successful year.

The following reports by officers, auditors, and tellers were presented and approved:

#### REPORT OF THE SECRETARY

During the Academy year—January 19, 1951, to January 17, 1952—62 persons were elected to regular membership, including 56 to resident and 6 to nonresident (125 were elected last year). Of these, 27 resident and 5 nonresident qualified for membership. Twenty-two resident and 5 nonresident members elected in the preceding Academy year qualified during the year just ended. Six elected to resident membership on January 14, 1952, have not yet been notified of their election. The new members were distributed among the various sciences as follows: 13 in physics, 12 in chemistry, 6 in bacteriology, 5 in pathology, 4 each in mathematics and physiology, 3 in parasitology, 2 each in botany and zoology, and 1 each in animal husbandry, entomology, hydrography, mammalogy, metrology, nucleonics, pomology, and soil science. Two resident members, having retired from the gainful practice of their professions, were placed on the retired list entitled to privileges of active membership without further payment of dues. Eleven

resident and four nonresident members resigned in good standing. Two resident members were dropped for nonpayment of dues.

The deaths of the following 11 members have been reported to the Secretary:

- MAURICE I. SMITH, Bethesda, Md., on January 26, 1951.
- OWEN B. FRENCH, Lakewood, Ohio, on February 12, 1951.
- CLARIBEL R. BARNETT, Washington, D. C., on March 6, 1951.
- HENRY SOLON GRAVES, Brattleboro, Vt., on March 7, 1951.
- BAILEY E. BROWN, Washington, D. C., on March 9, 1951.
- WILLIAM F. ALLEN, Portland, Oreg., on March 11, 1951.
- MERRILL BERNARD, Washington, D. C., on April 13, 1951.
- EARL K. FISCHER, Washington, D. C., on August 3, 1951.
- DANIEL L. HAZARD, Narragansett, R. I., on September 21, 1951.
- OSCAR B. HUNTER, Washington, D. C., on December 19, 1951.
- RUFUS H. SARGENT, Washington, D. C., on December 28, 1951.

On January 17, 1952, the status of membership was as follows:

	Regular	Retired	Honorary	Patron	Total
Resident.....	589	56	0	0	645
Nonresident.....	190	33	10	0	233
Total.....	779	89	10	0	878

The net changes in membership during the past year are as follows:

	Regular	Retired	Honorary	Patron	Total
Resident.....	+16	-1	0	0	+15
Nonresident.....	+17	-1	0	0	+16
Total.....	+33	-2	0	0	+31

During the Academy year 1951 the Board of Managers held 9 meetings with an average attendance of 18. The following summarizes items of interest in connection with Board Meetings:

The Managers felt that the membership would approve, as a matter of economizing, the discontinuance of sending engraved certificates of membership to newly elected members. The supply of certificates was exhausted in April, and the issuance of certificates of membership has been discontinued.

The Academy has continued to sponsor support of the Annual Science Fair and of the weekly issue of the Science Calendar in local newspapers.

The Committee on Grants-in-Aid for Research, Dr. L. E. YOCUM, Chairman, recommended grants from the funds allocated only for use for this purpose by the American Association for the Advancement of Science. Such funds accrue on the basis of the number of Academy members who also have membership in the AAAS. The Managers approved the recommendation of grants totaling \$430 to (1) Dr. FRANCIS E. FOX and Dr. Karl H. LANGENSTRASS for the purchase of materials to be used in supersonic studies; (2) Dr. MARTIN RUBIN and Dr. M. X. SULLIVAN for the purchase of materials in connection with metabolism studies; and (3) C. H. WALTHER for the purchase of materials in connection with photoelastic studies.

The suggestion that the age limit be raised above 40 years for nominees for the Academy's Awards for Scientific Achievement was again considered. The Managers agreed that the basis of the Award should remain one of recognition and encouragement of younger scientists, and that the age limit should not be raised.

A special Committee on Indexing the JOURNAL, former president J. E. GRAF, Chairman, appointed to make recommendations as to the disposition to be made of the recently completed index to the JOURNAL of the Washington Academy, presented its preliminary report at the 447th meeting of the Board. After considerable discussion at this and several other meetings of the Board, the Managers decided to publish a combined single index of the JOURNAL and the earlier PROCEEDINGS.

During the Academy year, 9 meetings of the Academy were held, as follows:

On February 15, 1951, FRANCIS B. SILSBEE, chief, Electricity Division, National Bureau of Standards, delivered his retiring presidential address on *Measure for measure: Some problems and paradoxes of precision* (published in this JOURNAL 41: 213-226, 1951).

On March 15, 1951, the 1950 Academy Awards were presented to SAMUEL LEVY, National

Bureau of Standards, for his work in the engineering sciences; PHILIP H. ABELSON, Department of Terrestrial Magnetism, Carnegie Institution of Washington, for work in the physical sciences, and to DAVID H. DUNKLE, U. S. National Museum, for work in the biological sciences. In their responses the recipients gave interesting summaries of the work on which the awards were based. The Academy also awarded Certificates of Merit to three outstanding high school students: PAUL E. CONDON, CECILIA GREEN, and DONALD L. MILLER.

On April 19, 1951, VICTOR H. HAAS, director of the National Microbiological Institute, National Institutes of Health, gave an illustrated lecture on *Disaster and disease* (published in this JOURNAL 41: 277-284, 1951).

On May 17, 1951, D. J. PARSONS, chief of the Scientific Laboratories of the Federal Bureau of Investigation, gave an illustrated lecture on *Science in crime detection*.

On October 18, 1951, FRANK H. H. ROBERTS, Jr., associate director, Bureau of American Ethnology, and director of the River Basin Surveys, gave an illustrated lecture on *Archeology and the Federal River Basin program*.

On November 15, 1951, DEITLEV W. BRONK, president of Johns Hopkins University and president of the National Academy of Sciences, gave a lecture on *The impact of the emergency on fundamental sciences*.

On December 20, 1951, WILLIAM E. HIATT, chief, Hydrologic Services Division, U. S. Weather Bureau, gave a lecture on *Precipitation and our water supply*.

The Annual Dinner meeting was held at 2400 Sixteenth Street on January 17, 1952. THOMAS R. HENRY, a member of the Fourth Byrd Antarctic Expedition in 1946-1947, delivered a lecture on *The White Continent* and presented the movie entitled *The Secret Land*.

F. M. DEFENDORF.

#### REPORT OF THE TREASURER

The Treasurer submits the following report concerning the finances of the Washington Academy of Sciences for the year ending December 31, 1951:

RECEIPTS	
Dues, 1948.....	\$ 6.00
1949.....	24.00
1950.....	136.00
1951.....	4,016.84
1952.....	62.00
	<hr/>
	\$4,244.84

Journal				Contribution to Science Fair		100.00	100.00
Subscriptions, 1950	42.75			Contribution to Science Calendar	55.00		55.00
1951	656.23			Refunds			
1952	805.51			Subscriptions	15.19		15.19
1953	15.39	1,519.88		Overpayments	2.00		2.00
Reprints, 1950	432.52			Collection charge	0.15		0.15
1951	701.47	1,133.99		Totals	\$934.21	\$10,140.90	\$11,075.11
Sales, 1951		179.89		Cash book balance as of Dec. 31, 1951			4,078.07
Interest, 1951		268.00		Total accounted for			\$15,153.18
Dividends, 1950	160.00			RECONCILIATION OF BANK BALANCE			
1951	2,104.67	2,264.67		Cash book balance, Dec. 31, 1951		\$4,078.07	
Directory, 33d ed.		1.00		Balance as per Am. Sec. & Trust Co. statement of Dec. 17, 1951		\$2,481.50	
Monograph no. 1		76.50		Receipts undeposited		1,715.32	
Transferred from savings account		1,000.00					\$4,196.82
Transferred from invested funds		1,000.00		Checks outstanding as of Dec. 31, 1951			
Annual dinner (1951)		364.00		No. 1018	\$ 5.41		
Contributions for Science Calendar		61.09		1263	5.00		
Receipts from <i>Kon-Tiki</i> showing		1,185.00		1509	27.79		
Grants from Amer. Assoc. Adv. Sci.		430.00		1511	11.57		
Overpayments		1.55		1512	64.98		
Refund of air-mail postage		0.24		1513	4.00		118.75
Total receipts, 1951		\$13,730.65		Total accounted for		\$4,078.07	
Cash book balance as of Jan. 1, 1951		1,422.53		INVESTMENTS			
Total to be accounted for		\$15,153.18		<i>Potomac Electric Power Co.</i>			
DISBURSEMENTS				Certificate No. TAO 1977—40			
	1950	1951	Total	shares 3.6% pref. at \$41			\$1,640.00
Secretary's Office	\$152.87	\$321.15	\$474.02	<i>City of New York</i>			
Treasurer's Office		87.74	87.74	3% (Transit Unification) Due June 1, 1980			
Subscription Manager & Custodian of Publications	0.59	44.35	44.94	Certificate No.			
Archivist		30.00	30.00	D 20186	\$ 500.00		
Meetings Committee		207.45	207.45	C 71038	100.00		
Journal Printing & mailing	592.90	5,369.61	5,962.51	C 71039	100.00		
Illustrations	9.76	600.30	610.06	C 71040	100.00		
Reprints	148.84	696.23	845.07	At \$108.50 per \$100	\$ 800.00		\$88.00
Office Editorial Asst.	25.00	275.00	300.00	<i>Northwestern Federal Savings &amp; Loan Association</i>			
Miscellaneous	3.36	27.87	31.23	Certificate No.			
Monograph no. 1	0.89	30.14	31.03	1380	\$4,500.00		
Forty-year Index		700.00	700.00	1441	500.00		\$ 5,000.00
Annual dinner, 1951		393.72	393.72				
<i>Kon-Tiki</i> showing Expenses		408.78	408.78				
Balance to Science Fair		776.22	776.22				



United States Government

Series G Bonds—No.

M 33299OG.....	1,000.00	
M 332991G.....	1,000.00	
M 332992G.....	1,000.00	
M 332993G.....	1,000.00	
M 1808741G.....	1,000.00	
M 2226088G.....	1,000.00	
M 2382748G.....	1,000.00	
M 4126041G.....	1,000.00	
M 5141346G.....	1,000.00	
M 5141347G.....	1,000.00	\$10,000.00

Massachusetts Investors Trust

412 shares at \$37.80.....	15,573.60	
----------------------------	-----------	--

Investment Company of America

400 shares at \$11.95.....	4,780.00	
----------------------------	----------	--

State Street Investment Corporation

100 shares at \$62.00.....	6,200.00	
----------------------------	----------	--

American Security and Trust Co.

Savings Account.....	161.52	
----------------------	--------	--

Total.....	\$44,223.12	
------------	-------------	--

Cash book balance, Dec. 31, 1951.....	4,078.07	
---------------------------------------	----------	--

Total.....	\$48,301.19	
------------	-------------	--

Total as of Dec. 31, 1951.....	\$48,301.19	
--------------------------------	-------------	--

Total as of Dec. 31, 1950.....	45,601.05	
--------------------------------	-----------	--

Increase.....	\$ 2,700.14	
---------------	-------------	--

At the close of business January 5, 1952, there were 58 members of the Academy in arrears, 28 for 1 year, 14 for 2 years, 4 for 3 years, 3 for 4 years, 7 for 5 years, and 2 for 6 years.

HOWARD S. RAPPLEYE.

REPORT OF AUDITING COMMITTEE

Your auditing committee examined the Treasurer's report and checked it with the account books, vouchers, canceled checks, bank statements, and the contents of the safe deposit box. We found the accounts correct as reported by the Treasurer, and all records very complete and in remarkably good order.

N. F. BRAATEN  
W. J. YOUSEN  
J. H. MARTIN, *Chairman.*

REPORT OF THE ARCHIVIST

The records of the Academy in possession of the Archivist have been available for consultation during the year. Ten volumes of the JOURNAL were bound to bring the Archivist's set up-to-date. No additional records were deposited during the year.

JOHN A. STEVENSON.

REPORT OF THE BOARD OF EDITORS

Volume 41 of the JOURNAL, brought out during 1951, includes 404 numbered pages, together with a portrait, an unnumbered page stating the dates of publication, and the title page. In addition to a 4-page index, and to Proceedings of the Academy and of the Anthropological Society aggregating 12 pages, it contains 86 papers distributed among several fields of science as follows: Mathematics, 4; physics, 2; astronomy, 1; geology, petrology, and paleontology, 12; botany, 7; zoology and its branches, 50; archeology and ethnology, 9; medicine, 1. Because of limited funds it was necessary to delay publication of many meritorious papers until 1952.

The disbursements for the JOURNAL during 1951 were:

Printing, engraving, wrapping, mailing, etc.....	\$6,563.38
Reprints.....	860.68
Office—editorial assistant.....	300.00
Office—postage.....	29.40

Total.....	\$7,753.46
Charges to authors.....	1,251.97

Net cost of Volume 41 to the Academy.....	\$6,501.49
---	------------

Help given by the officers of the Academy and by the Board of Managers is gratefully acknowledged. Thanks are due especially to Mr. PAUL H. OEHSER for his competent handling of technical matters concerned in printing the Journal.

CHARLES DRECHSLER  
WILLIAM F. FOSHAG  
J. P. E. MORRISON

REPORT OF CUSTODIAN AND SUBSCRIPTION MANAGER OF PUBLICATIONS

*Subscriptions*

Nonmember subscriptions in the continental United States.....	141
Nonmember subscriptions in U. S. possessions and foreign lands.....	68
Total.....	209

This is a decrease of 18 subscriptions from last year's total. Most of this loss is in the foreign list, where, because of exchange difficulties and other disturbed conditions, several subscriptions have had to be canceled. The above total still contains some names that will have to be crossed off.

*Inventory of stock as of December 31, 1951*

<i>Reserve sets of the Journal</i>	
Complete sets, vols. 1-41.....	2 sets
Volumes 11-41.....	6 sets
16-41.....	9 sets
21-41.....	7 sets
Total sets more or less complete.....	24 sets
<i>Back numbers of the Journal</i>	
Numbers held in complete sets (2)....	1,350
Numbers held in reserve for complete sets.....	8,539
Numbers held for sale separately*... not counted	
<i>Proceedings</i>	
Complete sets, volumes 1-13 (1899-1911).....	48 sets
(The copies of the separate articles that appeared in the Proceedings have never been counted.)	
<i>Monograph No. 1</i>	
Original issue.....	1,010
Copies sold or otherwise distributed....	173
Copies on hand.....	837

\* It has still not been possible to make a complete recount of these numbers. An improvement in the storage facilities to be made this coming year will permit counting and a rearrangement of the numbers on hand.

*Sales*

During the year 1951 the sales of the JOURNAL were considerably larger than those for 1950. Two complete sets were sold, one to the University at Glasgow, Scotland, and the other to the Institut Royal des Sciences Naturelles de Belgique in Brussels. Of the numbers of the JOURNAL 258 were sold, either separately or as volumes.

Fourteen numbers of the PROCEEDINGS were sold during the past year, and one copy of the 1947-48 Directory.

The sales of the Monograph again fell off to some extent. Thirty-two copies were sold—5 to the author (at a 20 per cent discount), 22 to dealers (at a 10 per cent discount), and 5 directly. An advertising campaign to publicize the book was instituted last September. Five hundred double postal cards, advertising the book, were sent to libraries all over the United States and its possessions. It is rather astonishing that not one of the 500 reply postal cards was returned, even though it meant only tearing off the reply half, checking and signing it, and mailing it at no extra expense. This campaign did, however, bring about some sales, for in due time numerous orders were received destined for some of the institutions circularized.

Some thought should be given, however, to ways and means of increasing the sales of the Monograph, even if it means reducing the price. In its first year 67 copies were sold; 47 were sold in the following year, and last year 32 were sold. At this rate it will be 15 years or more before half of the edition is sold.

Once again the Academy is indebted to the members who donated back numbers of the JOURNAL to this office. We are especially grateful to Dr. EDGAR D. TILLYER and to Miss MARY D. QUINT, librarian of the American Optical Co. of Southbridge, Mass., for sending us a set of the JOURNAL complete except for the earliest volumes and for some numbers missing here and there.

The income from sales of copies of the Journal, Proceedings, and Directories was \$179.89, and sales of the Monograph yielded \$76.50, a total income from sales of \$256.39.

*Expenditures*

Supplies.....	\$13.78
Purchase of back numbers.....	.50
Postage expended in connection with JOURNAL, etc.....	11.47
Postage expended in connection with Monograph.....	4.01
Sales campaign for Monograph.....	26.13
Telephone.....	1.22
Freight charges for shipping complete sets to New York.....	9.63
Total.....	\$66.74

*Storage*

Some progress was made in the rearrangement of the storage facilities that we have in the Smithsonian Institution Building. It is hoped that the addition of necessary lighting and an improvement in the shelving arrangement can be made this year, in which case it is expected that this project can be finished and a complete count be made of the stock.

HARALD A. REHDER.

## REPORT OF THE COMMITTEE ON MEMBERSHIP

It is the function of this Committee (1) to receive, examine, and evaluate nominations submitted from various sources, (2) to recommend to the Board the names and qualifications of nominees it considers acceptable for membership, (3) to find eligible scientists who are not members of the Academy and to prepare nominations for them, and (4) to encourage and aid members of the Academy to submit nominations.

Members of the Committee have been very active in searching for potential members, especially in their own organizations. The committee has examined about 80 nominations during the year, and has recommended to the Board 75 for resident and 2 for nonresident membership.

The recent raising of the maximum number of Academy members from 800 to 1,000 places on this committee the responsibility of reducing this gap. To aid its work there have been mimeographed two supplemental lists of nominees and new members since the appearance of the last Red Book in 1948. We are surprised, on looking into the matter, to find many eminent scientists who have never been invited to become members of the Academy. Plans are being made to extend the Committee and to reach into hitherto untouched fields. Especially, the Committee urges all Academy members to exercise their privilege of preparing and submitting nominations. A high standard will be maintained in evaluating all nominations before submitting them to the Board. **EGBERT H. WALKER, Chairman.**

#### REPORT OF COMMITTEE ON AWARDS FOR SCIENTIFIC ACHIEVEMENT

At the meeting of the Board of Managers on January 14, 1952, the recommendations of the Committee and its Subcommittees on Awards for Scientific Achievement for the year 1951 were approved. The awards to be presented this year, therefore, are

(1) In the Physical Sciences, to **MILTON SEYMOUR SCHECHTER**, of the Bureau of Entomology and Plant Quarantine, in recognition of his distinguished research in insecticide chemistry.

(2) In the Engineering Sciences, to **MAX A. KOHLER**, of the U. S. Weather Bureau in recognition of his distinguished investigations of rainfall, run-off, and flood predictions.

(3) In the Biological Sciences, to **EDWARD WILLIAM BAKER**, of the Bureau of Entomology and Plant Quarantine, in recognition of his distinguished research on the Acarina, or mites.

In lieu of a regular award with the 40-year age limitation, a special award, the first to be presented for the Teaching of Science, will be granted this year. **HOWARD B. OWENS**, of Prince Georges County, Md., has been selected for this special award in recognition of his outstanding teaching and for his work in arousing the enthusiasm of students in science.

The chairman wishes to express appreciation for the good work of the subcommittees and their respective chairmen, **G. H. COONS**, **R. S. DILL**, and **B. D. VAN EVERA**.

**GEORGE P. WALTON, General Chairman.**

#### REPORT OF THE COMMITTEE ON ENCOURAGEMENT OF SCIENCE TALENT

The Committee arranged the participation of the Academy in the Tenth National Science Talent Search of the Westinghouse Educational Foundation, as sponsor of the Third Annual Science Talent Search in the District of Columbia. Continuation of this work was assured by agreements for conducting the Fourth Search this year.

Last year's search resulted in the recommendation by the Committee of three local participants in the national search to the Academy's Board of Managers for the award of a Certificate of Merit from the Academy. The awards were presented by the Academy at its Annual Honors Meeting on March 15, 1951.

The Academy, through the medium of this Committee, again sponsored the Annual Science Fair for local high and junior high school students, in cooperation with the science departments of the Public Schools of the District of Columbia. The Fifth Science Fair was held April 14-19, 1951, in the lobby of the Department of Commerce Building, with 423 exhibits selected for display from about 1500 prepared in the schools. Two boy and two girl exhibitors were selected to compete in the National Science Fair held at St. Louis among 44 winners of the local fair.

An unusual opportunity was seized by the Committee to arrange for the Academy to sponsor a gala premier showing of the motion picture *Kon-Tiki* at the Dupont Theater for the benefit of the Science Fair. A sum of \$776.22 was realized, which will be employed to support the National Science Fair to be held in Washington this spring.

The Committee arranged for the Academy to solicit funds from its affiliated societies in support of the Science Fair. A total of \$438 was received, including \$100 from the Academy.

The membership of the Committee during the year was: **W. L. SCHMITT**, **J. M. CALDWELL**, **F. L. MOHLER**, **A. H. CLARK**, **A. T. MCPHERSON**, and **M. A. MASON**, Chairman. The Chairman takes this opportunity to commend the excellent

support of these members, and particularly to express his appreciation to A. T. McPHERSON, who has been outstanding in his leadership and enthusiasm in the work of the committee.

MARTIN A. MASON, *Chairman*.

Vice-President FAHEY on behalf of the Academy expressed appreciation (1) for the work of the Meetings Committee, Dr. MARGARET PITTMAN, Chairman; (2) for the work of the Committee on Grants-In-Aid for Research, Dr. L. E. YOCUM, Chairman; (3) for the work of the Committee on Indexing the Journal, former president J. E. GRAF, Chairman; and (4) to the Committee on Monographs, J. R. SWALLEN, Chairman.

After acceptance by members of the report of the Chairman of the Committee of Tellers, Vice-President Fahey declared the following elected:

- FRANK M. SETZLER, *President-Elect*  
 FRANCIS M. DEFANDORF, *Secretary*  
 HOWARD S. RAPPLEYE, *Treasurer*  
 C. F. W. MUESEBECK, *Board of Managers to January 1953*  
 MILTON HARRIS, *Board of Managers to January 1954*  
 ROGER G. BATES and W. W. DIEHL, *Board of Managers to January 1955*.

The following members of the Academy, nominated by the Affiliated Societies, were duly elected Vice-Presidents of the Academy:

- Philosophical Society of Washington—ALVIN G. McNISH  
 Anthropological Society of Washington—WALDO WEDEL  
 Biological Society of Washington—HUGH T. O'NEILL  
 Chemical Society of Washington—JOHN K. TAYLOR  
 Entomological Society of Washington—FREDERICK W. POOS  
 National Geographic Society—ALEXANDER WETMORE  
 Geological Society of Washington—A. NELSON SAYRE  
 Medical Society of the District of Columbia—FRED O. COE  
 Columbia Historical Society—GILBERT GROSVENOR  
 Botanical Society of Washington—LEE M. HUTCHINS  
 Washington Section of the Society of American Foresters—WM. A. DAYTON  
 Washington Society of Engineers—CLIFFORD A. BETTS  
 Washington Section of the American Institute of Electrical Engineers—A. H. SCOTT

- Washington Section of the American Society of Mechanical Engineers—R. S. DILL  
 Helminthological Society of Washington—L. A. SPINDLER  
 Washington Branch of the Society of American Bacteriologists—A. M. GRIFFIN  
 Washington Post of the Society of American Military Engineers—FLOYD W. HOUGH  
 Washington Section of the Institute of Radio Engineers—HERBERT G. DORSEY  
 District of Columbia Section of the American Society of Civil Engineers—MARTIN A. MASON

Vice-President Fahey introduced the speaker, THOMAS R. HENRY, a member of the Washington Academy of Sciences and well known for his popular writings on scientific topics. Mr. Henry gave a graphic account of his impressions in visiting the White Continent, and then showed a movie entitled *The Secret Land*. This spectacular film was prepared by Metro-Goldwyn-Mayer Pictures from the moving pictures made by the U. S. Navy. Mr. Henry described the carefully planned Naval exploratory expedition of over 2,000 persons and spoke of the interesting discoveries in Antarctica made possible by the full use of modern equipment. Aerial photographs of more than one million square miles of Antarctica were made using aircraft. Numerous additional photographic records and scientific studies were obtained by exploration parties that made use of dog teams and a variety of automotive propelled surface vehicles.

Vice-President Fahey introduced the new President, WALTER R. RAMBERG, who had served as President-Elect during 1951. After appropriate remarks the new President adjourned the meeting at 10:35 P.M.

F. M. DEFANDORF, *Secretary*.

#### 454TH MEETING OF BOARD OF MANAGERS

The 454th meeting of the Board of Managers, held in the Cosmos Club on March 17, 1952, was called to order at 8:02 P.M. by President RAMBERG. Others attending were: H. S. RAPPLEYE, J. A. STEVENSON, W. F. FOSHAG, R. G. BATES, A. G. McNISH, H. T. O'NEILL, W. A. DAYTON, A. H. SCOTT, H. G. DORSEY, M. A. MASON, F. M. DEFANDORF, and, by invitation, E. H. WALKER, J. R. SWALLEN, L. E. YOCUM, and W. T. READ.

President RAMBERG announced the appointment of CLARENCE COTTAM, REECE I. SAILER, LEO A. SHINN, and FRANK KRACEK to the Committee on Membership.

The resignation of STEPHEN BRUNAUER was approved as of December 31, 1951. The Treasurer mentioned that the grant of research funds (\$170) from the American Association for the Advancement of Science made to KARL H. LANGENSTRASS and FRANCIS E. FOX had not been used. This amount will be available for a new grant.

The recommendation in the report of the Committee on Encouragement of Science Talent that the Academy should proceed with the organization of a Junior Academy of Science was discussed. The Board approved a motion that the President appoint a special committee for the Consideration of the Establishing of a Junior Academy of Sciences in Washington. It was understood that this committee will develop and present its detailed recommendations to the Board.

The meeting adjourned at 9:20 P.M.

#### 455TH MEETING OF BOARD OF MANAGERS

The 455th meeting of the Board of Managers held in the Cosmos Club on April 7, 1952, was called to order at 8:03 P.M. by President RAMBERG. Others attending were: F. M. SETZLER, H. S. RAPPLEYE, J. A. STEVENSON, SARA E. BRANHAM, R. G. BATES, W. W. DIEHL, A. G. MCNISH, J. K. TAYLOR, F. W. POOS, A. N. SAYRE, L. M. HUTCHINS, W. A. DAYTON, C. A. BETTS, A. H. SCOTT, A. M. GRIFFIN, F. W. HOUGH, M. A. MASON, F. M. DEFANDORF, and, by invitation, H. W. WELLS and A. T. MCPHERSON.

President Ramberg announced that he had made the following appointments to the Special Committee suggested at the last meeting of the Board to be known as the Junior Academy of Sciences Committee: MARTIN A. MASON, Chairman, A. T. MCPHERSON, E. H. WALKER. He also announced the appointment of JOHN FABER and EDWARD G. REINHARD to the Membership Committee.

The Secretary read the following minutes:

An Executive Committee Meeting was held at 8:30 P.M., April 7, 1952, with Messrs. RAMBERG, SETZLER, DAYTON, and DEFANDORF in attendance.

There was a discussion about the part that the Washington Academy might play in sponsoring the formation of a Junior Academy of Sciences, and President RAMBERG spoke of the interest of MESSRS. MASON, MCPHERSON and WALKER, whom he had appointed to serve on a special committee for this purpose in this project.

In connection with the coming National Science Fair, Science Service has requested the selection of a list of about 160 interested scientists belonging to the Affiliated Societies who will be invited to a special early showing of the exhibits at the Fair. This group of Washington scientists and engineers will be invited to a dinner to be given in honor of the winners in their respective local Science Fairs, and it is anticipated that about 80 will be willing to support the dinner as hosts to these students. As sponsor, the Washington Academy of Sciences will be asked to contribute the dinners for the student exhibitors. The cost is expected to be of the order of \$250. The Executive Committee agreed that this worthwhile project should receive the support of the Academy. Plans for making a suitable list of members of Affiliated Societies available to Miss PATTERSON, of Science Service, were discussed.

The matter of support for publishing the Index of the JOURNAL for which the page proof has been received by the Secretary was considered.

H. W. WELLS, Chairman of the Meetings Committee, announced that this Committee, at its last meeting, discussed objectives and wondered (1) whether the meetings should tend more toward joint meetings with the Affiliated Societies in order to knit them more closely to the Academy; (2) whether there should be an attempt to increase interest in technical meetings; (3) whether there should be regular monthly meetings to stimulate student interest; and (4) whether a fall meeting of two or three days of papers to be arranged for Affiliated Society participation, similar to the National Academy meetings, with each group responsible for three to six papers, should be considered.

In the ensuing discussion Dr. BRANHAM pointed out that the latter program might be effective in bringing the Affiliated Societies together in a closer knit organization. Mr. SETZLER pointed out difficulties entailed in completing arrangements unless meetings are held on a regular meeting date basis, and both he and Dr. MASON emphasized the work entailed in arranging symposia. Dr. MASON also spoke of the numerous technical meetings now provided for by the various Affiliated Societies which, if participated in, are adequate to exhaust the mental, physical, and financial abilities of local scientists and engineers. He suggested that one or two meetings covering the broader fields of science might help fulfill the functions of the Academy as a coordinating society and would serve to orient those members who have no idea of what the Academy is supposed to do. Mr. SETZLER

pointed out that according to the bylaws two meetings are stipulated: The Annual Meeting and the Presidential Address meeting. President RAMBERG mentioned that a third meeting, the Awards Meeting, should certainly be assured as an annual affair. It is up to the Meetings Committee to make arrangements for any additional meetings. To insure a regular meeting place and time, the Cosmos Club Auditorium is reserved for the third Thursday evening in each month. Irregular or special meetings require that special arrangements be made well in advance of the proposed meetings. In conclusion President RAMBERG requested that the Vice Presidents bring the matter before the Affiliated Societies and report any suggestions of ways in which the Academy might be helpful.

For the Committee on Encouragement of Science Talent, Dr. A. T. McPHERSON, Chairman, reported his group had been cooperating with the teachers on the Local Science Fair. The Washington Daily News will share in the responsibility for this Fair, for which most of the expenses have been assured by the Academy-sponsored showing of the film *Kon-Tiki*. He emphasized that teachers in the local schools want scientists who will come to answer the questions of their students about science as a career, and others who will help inspirationally by preparing and giving classroom talks. He reported that only one completed blank, out of those made available at the last Board meeting, had been received, namely, one filled in by Dr. A. G. McNISH. On the other hand, the Engineers have 60 engineers listed on similar blanks distributed through member organizations of the D. C. Council of Engineering and Architectural Societies. He deplored the unbalanced representation that will exist unless able physicists, chemists, biologists and other scientists come forward and offer to provide the needed help. Dr. McPHERSON stated that personal contact of scientists with students is highly desirable, and mentioned that he had blanks with him for those who might be willing to fill them in.

Dr. McPHERSON explained that the aim of the Management of the National Science Fair in requesting a list of 160 scientists to participate in the Special Scientists Night was to locate those interested in, and who would be at ease with these young people—boy and girl winners of local science fairs from all over the country.

This event entails the privilege of playing host to future scientists, and should in no way be considered a chore.

In order to complete the desired list by Friday, April 11, President RAMBERG suggested an apportionment of numbers among the Affiliated Societies. Vice Presidents of the Academy and Directors of local scientific agencies will be included in this listing.

On motion duly seconded the Board approved a special appropriation of a fund not to exceed \$250 for providing dinners for student fair participants at the National Science Fair Dinner.

The Secretary reported 337 ballots were received for election of the District of Columbia Section of the Society of Experimental Biology and Medicine to become an Affiliated Society of the Washington Academy of Sciences, confirming the earlier approval by the Board and completing the requirements for Affiliation of the District of Columbia Section of the Society of Experimental Biology and Medicine with the Washington Academy of Sciences.

The following letter from President RAMBERG to the Secretary, dated April 2, was read:

I am pleased to transmit to you herewith three books of records as follows:

1. Minutes of Proceedings of the Joint Commission of Scientific Societies of Washington from its organization February 25, 1888, to 1897, preceded by the Minutes of the organizing committee. 1892.
2. Minutes of Proceedings of the Joint Commission of Scientific Societies of Washington from 1897 to Vol. 2, 1897.
3. Directory of Scientific Societies of Washington. 1889 to 1898.

These records were found in cleaning out a storeroom in the Metallurgy Division of this Bureau. The Chief of the Metallurgy Division Mr. J. G. THOMPSON, immediately recognized their value and turned them over to me for disposition by the Academy.

The records give a complete history of the Joint Commission which preceded the establishment of the Washington Academy of Sciences. They should therefore occupy a place of honor in the archives of the Academy. I suggest that you announce their recovery at the next meeting of the Board of Managers and that proper recognition be given Mr. THOMPSON and his associates for finding them and returning them to the Academy.

These interesting bound records of the inception of the Washington Academy were turned over to the Archivist, J. A. STEVENSON, for preservation in the Archives of the Academy.

Treasurer RAPPLEYE read a letter of appreciation from F. E. FOX returning the unused AAAS grant of \$170 for purchasing equipment that he

fortunately was able to borrow for the completion of his project.

The meeting was adjourned at 9:35 P.M.

F. M. DEFANDORF, *Secretary*.

## Obituaries

THOMAS WAYLAND VAUGHAN, geologist, paleontologist, and oceanographer, died January 16, 1952, at the age of 81. He was born in Jonesville, Tex., on September 20, 1870. His undergraduate training was obtained at Tulane University, where he chose to major in physical science. At Tulane he took his first course in geology along with generous portions of physics, mathematics, and chemistry, and received a B.S. degree in 1889 at the age of 18 years. From 1889 to 1892 he was instructor in chemistry and physics at Mount Lebanon College in Louisiana, then went to Harvard, where he received an A.B. degree in one year, a master's degree in another, and his doctorate in 1903. Meanwhile, in 1894, he had joined the U. S. Geological Survey as assistant geologist. He continued in the Survey's employ for many years, becoming geologist-in-charge of Coastal Plains investigations in 1907, at the age of 37 years. In 1903 he was appointed custodian of the madreporarian corals in the U. S. National Museum. In 1924 he gave up governmental work in Washington and went to La Jolla, Calif., as professor of oceanography at the University of California and director of its Scripps Institution of Oceanography. In this position he was very active for a dozen years and largely through his efforts Scripps evolved from a seaside biological laboratory to the leading oceanographic institution of the world. During all these years he was generous in giving assistance to others, and he had the foresight to train successors in the many fields that claimed his attention.

Wayland Vaughan had every reason to be proud of his accomplishments and of the recognition that followed. No attempt will be made to enumerate the societies to which he was elected, both in this country and abroad, the high offices that he held in many of them, or to list the medals conferred upon him. Among others, one foreign government awarded a decoration, and three universities, two in this country and one in Canada, conferred honorary doctor's degrees. One of his last honors came less than a year ago when, with impressive ceremonies, the

Scripps Institution named its newest and finest building for him. Additional honors awaited him had he lived, as several volumes on geology and ecology now nearing publication have been dedicated to him.

Dr. Vaughan commanded the respect and admiration due a talented and prodigious worker who was able to pursue his career actively for a period of 60 years and to write several hundred scientific papers. This, however, is only a part of the story. He was truly unique in his ability to shift his interest and enter related or entirely new fields of investigation. Starting with investigations of the geology of the Atlantic and Gulf Coastal Plains, he expanded his studies into eastern Mexico, the West Indies, and Panama. He became the leading authority on the Mesozoic, Cenozoic, and Recent corals of these areas including their ecology, paleoecology, and reef-building characteristics. At a comparatively late date—about 1923, when he was 54 years old—he undertook the study of an even more difficult group, the larger Foraminifera, and wrote monographic papers on these organisms. At about this same time he moved to the west coast and turned to oceanography. To this field he brought a knowledge of marine organisms and marine sediments; but it also called for a broad knowledge of physical oceanography, and he had to review and supplement his early studies, particularly in the field of mathematics. During a trip around the world in 1932-33, to survey oceanographic facilities for the National Academy of Sciences, he became interested in oriental art, a study that took up much of his spare time in the years that followed. He pursued it so assiduously that in California he was in even greater demand as a lecturer on oriental art than in his main fields of geology and oceanography. In 1934, at the age of 64 years, while recovering from a severe illness, he undertook the study of the Japanese language and actually attained considerable proficiency in this field. When he reached 65 he was automatically retired as Director of Scripps, but he could have remained at the

Institution as Professor of Oceanography. He chose, instead, to return to Washington to resume his paleontological studies at the U. S. National Museum. In 1947, he became partly blind after a severe attack of pneumonia. This ended his scientific work, but until his last illness he maintained his interest in the scientific work of others and in the workers themselves. He was indeed an outstanding scientist, and this brief summary does not do justice to his tremendous productivity.

H. S. LADD.

The passing of Dr. WALTER T. SWINGLE on January 19 last was a very heavy loss to the botanical and agricultural sciences. There are, of course, hundreds of distinguished workers in these fields in the United States, but the writer can think of no one with precisely the rare combination of a brilliant and highly original mind with extensive and profound knowledge, that made Swingle preeminent in these fields. To these gifts were added an unflinching kindness and willingness to share with others his great store of learning and experience.

Born in Canaan, Pa., in 1871, his boyhood was spent in Kansas where he entered the State Agricultural College at Manhattan, receiving the degrees of B.Sc. and M.Sc., in 1890 and 1896, respectively. His alma mater honored him with the degree of D.Sc. in 1922.

He was called to the U. S. Department of Agriculture at the early age of 20 and remained an active member of the Department until his retirement in 1941. In 1895-96 and again in 1898 he was in Germany, studying at the Universities of Bonn and Leipzig. The opportunity of working in the laboratory of so eminent a botanist as Professor Strasburger, contributed greatly to his knowledge of cytology, one of the many fields in which he gained distinction. He was the first to prove the existence of centrosomes in plant cells.

During his sojourn in Germany, as previously at Manhattan and afterward in the Department of Agriculture, Swingle was closely associated with David Fairchild, an association continued, with mutual benefit, to the end of Swingle's life.

Upon his return to Washington he became engaged in the development of the Bureau of Plant Industry, which owes much of its usefulness to his efforts. Many projects that are still

pursued actively in the Bureau originated in the fertile brain of Swingle.

Agricultural exploration soon engaged his attention and this work took him to French North Africa and other parts of the Mediterranean region, and later to China, Japan, the Philippines and Brazil. Two of the outstanding results of these explorations were the first successful introduction of the caprifig wasp, upon which the prosperity of the Smyrna-type fig industry in California largely depends, and the establishment of a very flourishing date industry in that state and Arizona. His papers on date-growing in Algeria and on the caprifig are two of his most important publications.

With the late Dr. H. H. Webber, he spent several years in Florida investigating the citrus industry and making hundreds of hybrids. Perhaps the finest of these is the tangelo, which resulted from a cross between the tangerine and the grapefruit. This work led him into exhaustive investigations of the taxonomy of the orange subfamily. Some two dozen papers were published on this subject, and several new genera were described.

The establishment of the American-Egyptian cotton industry in Arizona, in which Dr. Swingle collaborated with other members of the Bureau of Plant Industry, was another of the projects to which his fertility of ideas contributed most effectively.

In collaboration with Dr. Lyman Briggs, he perfected the ultraviolet microscope, making it a most useful tool in botanical research.

Dr. Swingle was a fellow and life member of the American Association for the Advancement of Science, one of the founders of the Washington Academy of Sciences, and a member of the Washington Academy of Medicine, Botanical Society of America, and the Philadelphia Academy of Sciences; also an honorary life member of the National Geographic Society and a corresponding member of the Académie d'Agriculture de France. In 1926 he represented the U. S. Government and the National Research Council at the third Pan Pacific Science Congress, in Tokyo.

He married, in 1915, Maude Kellerman, herself the daughter of a distinguished botanist and the sister of a former associate chief of the Bureau of Plant Industry. She, and their two sons and two daughters, survive him.

T. H. KEARNEY.



## Officers of the Washington Academy of Sciences

President.....	WALTER RAMBERG, National Bureau of Standards
President-elect.....	F. M. SETZLER, U. S. National Museum
Secretary.....	F. M. DEFANDORF, National Bureau of Standards
Treasurer.....	HOWARD S. RAPPLEYE, U. S. Coast and Geodetic Survey
Archivist.....	JOHN A. STEVENSON, Plant Industry Station
Custodian and Subscription Manager of Publications.....	HARALD A. REHDER, U. S. National Museum

### Vice-presidents Representing the Affiliated Societies:

Philosophical Society of Washington.....	A. G. McNISH
Anthropological Society of Washington.....	WALDO R. WEDEL
Biological Society of Washington.....	HUGH T. O'NEILL
Chemical Society of Washington.....	JOHN K. TAYLOR
Entomological Society of Washington.....	FREDERICK W. POOS
National Geographic Society.....	ALEXANDER WETMORE
Geological Society of Washington.....	A. NELSON SAYRE
Medical Society of the District of Columbia.....	FRED O. COE
Columbia Historical Society.....	GILBERT GROSVENOR
Botanical Society of Washington.....	LEE M. HUTCHINS
Washington Section, Society of American Foresters.....	WILLIAM A. DAYTON
Washington Society of Engineers.....	CLIFFORD A. BETTS
Washington Section, American Institute of Electrical Engineers.....	A. H. SCOTT
Washington Section, American Society of Mechanical Engineers.....	RICHARD S. DILL
Helminthological Society of Washington.....	L. A. SPINDLER
Washington Branch, Society of American Bacteriologists.....	ANGUS M. GRIFFIN
Washington Post, Society of American Military Engineers.....	FLOYD W. HOUGH
Washington Section, Institute of Radio Engineers.....	HERBERT G. DORSEY
District of Columbia Section, American Society of Civil Engineers.....	MARTIN A. MASON
District of Columbia Section, Society for Experimental Biology and Medicine.....	N. R. ELLIS

### Elected Members of the Board of Managers:

To January 1953.....	C. F. W. MUESEBECK, A. T. MCPHERSON
To January 1954.....	SARA E. BRANHAM, MILTON HARRIS
To January 1955.....	ROGER G. BATES, W. W. DIEHL

*Board of Managers*..... All the above officers plus the Senior Editor

*Board of Editors and Associate Editors*..... [See front cover]

*Executive Committee*.... WALTER RAMBERG (chairman), F. M. SETZLER, H. S. RAPPLEYE, WILLIAM A. DAYTON, F. M. DEFANDORF

*Committee on Membership*... E. H. WALKER (chairman), M. S. ANDERSON, CLARENCE COTAM, R. C. DUNCAN, JOHN FABER, G. T. FAUST, I. B. HANSEN, FRANK KRACEK, D. B. JONES, E. G. REINHARD, REECE I. SAILER, LEO A. SHINN, F. A. SMITH, HEINZ SPECHT, H. M. TRENT, ALFRED WEISSLER

*Committee on Meetings*.... H. W. WELLS (chairman), WM. R. CAMPBELL, W. R. CHAPLINE, D. J. DAVIS, H. G. DORSEY, O. W. TORRESON

*Committee on Monographs* (W. N. FENTON, chairman):

To January 1953.....	R. W. IMLAY, P. W. OMAN
To January 1954.....	S. F. BLAKE, F. C. KRACEK
To January 1955.....	W. N. FENTON, ALAN STONE

*Committee on Awards for Scientific Achievement* (J. R. SWALLEN, general chairman):

For Biological Sciences.....	J. R. SWALLEN (chairman), L. M. HUTCHINS, MARGARET PITTMAN, F. W. POOS, L. P. SCHULTZ
For Engineering Sciences.....	R. C. DUNCAN (chairman), A. C. FIELDNER, WAYNE C. HALL, J. W. MCBURNEY, O. S. READING, H. L. WHITEMORE
For Physical Sciences.....	L. A. WOOD (chairman), P. H. ABELSON, F. S. DAFT, GEORGE W. IRVING, JR., J. H. McMILLEN

For Teaching of Science..... M. A. MASON (chairman), F. E. FOX, M. H. MARTIN

*Committee on Grants-in-aid for Research*..... L. E. YOCUM (chairman), H. N. EATON, K. F. HERZFELD

### Committee on Policy and Planning:

To January 1953.....	W. A. DAYTON (chairman), N. R. SMITH
To January 1954.....	H. B. COLLINS, JR., W. W. RUBEY
To January 1955.....	L. W. PARR, F. B. SILSBEE

*Committee on Encouragement of Science Talent* (A. T. MCPHERSON, chairman):

To January 1953.....	A. H. CLARK, F. L. MOHLER
To January 1954.....	J. M. CALDWELL, W. L. SCHMITT
To January 1955.....	A. T. MCPHERSON, W. T. READ

*Representative on Council of A. A. A. S.*..... F. M. SETZLER

*Committee of Auditors*..... C. L. GAZIN (chairman), LOUISE M. RUSSELL, D. R. TATE

*Committee of Tellers*... GEORGE P. WALTON (chairman), GEORGE H. COONS, C. L. GARNER

## CONTENTS

	Page
BIOCHEMISTRY.—Reaction of normal and mutant plastids of <i>Nicotiana</i> to neotetrazolium. M. W. WOODS, JANE L. SHOWACRE, and H. G. DU BUY.....	169
GEOLOGY.—The base of the Cambrian in the southern Appalachians. PHILIP B. KING.....	170
PALEONTOLOGY.—A Cretaceous horseshoe crab from Colorado. J. B. REESIDE, JR., and D. V. HARRIS.....	174
BOTANY.—New mosses from southern Brazil. EDWIN B. BARTRAM... ..	178
ZOOLOGY.—New western Atlantic records of octocorals (Coelenterata: Anthozoa), with descriptions of three new species. FREDERICK M. BAYER.....	183
ZOOLOGY.—New Recent foraminiferal genera from the tropical Pacific. ALFRED R. LOEBLICH, JR.....	189
ZOOLOGY.—Fresh-water triclads (Turbellaria) of the Rocky Mountain National Park region, Colorado. ROMAN KENK.....	193
PROCEEDINGS: THE ACADEMY.....	198
OBITUARIES: Thomas Wayland Vaughan; Walter T. Swingle.....	207

506.73  
.D2W23

Vol. 42

JULY 1952

No. 7

# JOURNAL OF THE WASHINGTON ACADEMY OF SCIENCES

## BOARD OF EDITORS

WILLIAM F. FOSHAG  
U.S. NATIONAL MUSEUM

J. P. E. MORRISON  
U.S. NATIONAL MUSEUM

JOHN C. EWERS  
U.S. NATIONAL MUSEUM

## ASSOCIATE EDITORS

F. A. CHACE, JR.  
BIOLOGY

MIRIAM L. BOMHARD  
BOTANY

J. I. HOFFMAN  
CHEMISTRY

R. K. COOK  
PHYSICS AND MATHEMATICS

T. P. THAYER  
GEOLOGY

PHILIP DRUCKER  
ANTHROPOLOGY

C. W. SABROSKY  
ENTOMOLOGY



PUBLISHED MONTHLY  
BY THE

WASHINGTON ACADEMY OF SCIENCES  
MOUNT ROYAL & GUILFORD AVES.  
BALTIMORE, MARYLAND

Entered as second class matter under the Act of August 24, 1912, at Baltimore, Md.  
Acceptance for mailing at a special rate of postage provided for in the Act of February 28, 1925.  
Authorized February 17, 1949

## Journal of the Washington Academy of Sciences

This JOURNAL, the official organ of the Washington Academy of Sciences, publishes: (1) Short original papers, written or communicated by members of the Academy; (2) proceedings and programs of meetings of the Academy and affiliated societies; (3) notes of events connected with the scientific life of Washington. The JOURNAL is issued monthly. Volumes correspond to calendar years.

*Manuscripts* may be sent to any member of the Board of Editors. It is urgently requested that contributors consult the latest numbers of the JOURNAL and conform their manuscripts to the usage found there as regards arrangement of title, subheads, synonymies, footnotes, tables, bibliography, legends for illustrations, and other matter. Manuscripts should be typewritten, double-spaced, on good paper. Footnotes should be numbered serially in pencil and submitted on a separate sheet. The editors do not assume responsibility for the ideas expressed by the author, nor can they undertake to correct other than obvious minor errors.

*Illustrations* in excess of the equivalent (in cost) of one full-page halftone are to be paid for by the author.

*Proof.*—In order to facilitate prompt publication one proof will generally be sent to authors in or near Washington. It is urged that manuscript be submitted in final form; the editors will exercise due care in seeing that copy is followed.

*Unusual cost* of foreign, mathematical, and tabular material, as well as alterations made in the proof by the author, may be charged to the author.

*Author's Reprints.*—Reprints will be furnished in accordance with the following schedule of prices (approximate):

Copies	4 pp.	8 pp.	12 pp.	16 pp.	20 pp.	Covers
100	\$3.25	\$6.50	\$ 9.75	\$13.00	\$16.25	\$3.00
200	6.50	13.00	19.50	26.00	32.50	6.00
300	9.75	19.50	29.25	39.00	48.75	9.00
400	13.00	26.00	39.00	52.00	65.00	12.00

*Subscriptions* or requests for the purchase of back numbers or volumes of the JOURNAL or the PROCEEDINGS should be sent to HARALD A. REHDER, Custodian and Subscription Manager of Publications, U. S. National Museum, Washington 25, D. C.

*Subscription Rates* for the JOURNAL.—Per year..... \$7.50

Price of back numbers and volumes:	Per Vol.	Per Number
Vol. 1 to vol. 10, incl.—not available*.....	—	—
Vol. 11 to vol. 15, incl. (21 numbers per vol.).....	\$10.00	\$0.70
Vol. 16 to vol. 22, incl. (21 numbers per vol.).....	8.00	0.60
Vol. 23 to current vol. (12 numbers per vol.).....	7.50	0.90

\* Limited number of complete sets of the JOURNAL (vol. 1 to vol. 41, incl.) available for sale to libraries at \$348.50.

MONOGRAPH No. 1, "The Parasitic Cuckoos of Africa," by Herbert Friedmann. \$4.50

PROCEEDINGS, vols. 1-13 (1899-1911) complete..... \$25.00

Single volumes, unbound..... 2.00

Single numbers..... .25

*Missing Numbers* will be replaced without charge provided that claim is made to the Treasurer within 30 days after of following issue.

*Remittances* should be made payable to "Washington Academy of Sciences" and addressed to the Treasurer, H. S. RAPPLEYE, 6712 Fourth Street, N.W., Washington 12, D.C.

*Exchanges.*—The Academy does not exchange its publications for those of other societies.

# JOURNAL OF THE WASHINGTON ACADEMY OF SCIENCES

VOLUME 42

July 1952

No. 7

GEOLOGY.—*Lower limit of the Cambrian in the Cordilleran region.*<sup>1</sup> CHESTER R. LONGWELL, Yale University. (Communicated by James S. Williams.)

Cambrian and older rocks are widely distributed in the Cordilleran region, through thousands of miles in length and hundreds in width. The stratigraphic horizons of critical interest to our problem are particularly well displayed, (1) in British Columbia and (2) in the Basin and Range province of the United States, the area to which my first-hand acquaintance is limited, and to which most of my comments are restricted.

Current paleogeographic maps represent a Lower Cambrian seaway advancing north-eastward across much of the present Great Basin area, another southward across western Canada (Deiss, 1941). Deposits that record this early history are characterized by the *Olenellus* fauna; some earlier strata also commonly have been included. These were laid down on thick formations that commonly are classed as Precambrian, such as the Belt series of Montana and British Columbia which had been little deformed, and generally similar deposits in the Death Valley region that had been faulted, highly tilted, and otherwise disturbed. The concept of land areas of the time rests in part on facies relations, but in part merely on presently known distribution of outcrops; for example, the western limit of the southern seaway at the Nevada-California state line is shown almost exactly on the location of the thickest known section of the fossiliferous Silver Peak formation. This limit is kept in Deiss's synthetic map for all Cambrian seaways (1941, fig. 1). There is clear evidence of progressive overlap northward across what Deiss has called Montania, and eastward in the Colorado Plateau and Rocky Mountain areas. On the west, however, the

evidence on Cambrian geography is very vague indeed, since the older formations either end abruptly against plutonic masses, as at the border of the Sierra Nevada, or disappear under younger Paleozoic, Mesozoic, and Cenozoic cover, including the widespread Columbia River basalt. Nolan's sections (1928) show the clear relations in western Utah and eastern Nevada, and the lack of information in northern California, where Devonian beds rest on metamorphic and volcanic rocks. We know there was early Paleozoic volcanism in the coastal belt, and probably there was orogeny also. Eardley (1947) has offered a modification of Nolan's sections, suggesting that the Salmon and Abrams schists, of the Klamath region, may represent a westward continuation of known Cambrian and late Precambrian formations. It is not assured that continuous land bordered the Cordilleran geosyncline on the west.

However, more tangible evidence for our purpose lies inland. Stratigraphic relations are comparatively simple in the wide area traversed by the Grand Canyon, where little-deformed Cambrian beds lie across steeply tilted strata of the Grand Canyon series, which in turn rest on Archean schist, gneiss, and granite. The unmetamorphosed but strongly deformed Grand Canyon series is by general agreement Precambrian. In the overlying, nearly horizontal beds Cambrian faunas are found throughout the length of the Grand Canyon, although the lowest formation, the Tapeats sandstone, is apparently devoid of fossils. In the eastern part of the district the lowest significant fauna, found in the Bright Angel shale 135 feet above the Tapeats sandstone, indicates Middle Cambrian age. Near the mouth of the canyon the same faunal zone is more than

<sup>1</sup> Part of a symposium on "Base of the Cambrian System," held by the Geological Society of Washington, April 11, 1951.

400 feet above the Tapeats and above thin-bedded sandstone that contains a Lower Cambrian *Olenellus* fauna (McKee, 1945). Fifty miles farther west, at Frenchman Mountain in southern Nevada, the *Olenellus* faunal zone lies within the shale 80 feet above the Tapeats sandstone (Wheeler, 1947), which there rests on the Archean complex.

From Las Vegas westward the older part of the section thickens tremendously, with addition of formations whose age is uncertain. In sections east of Death Valley the *Olenellus* fauna has been reported from only the upper 900 feet of the Wood Canyon formation (Nolan, 1929; Hazzard, 1938), below which lie the Stirling quartzite, 4000 feet thick, the Johnnie formation, 2,500 to 4,000 feet, and the Noonday dolomite, 1500 feet. Thus in these sections 8,000 to 9,000 feet of strata, largely clastic, underlie without obvious angular unconformity the lowest beds now known to contain *Olenellus*. This thick section lies with strong angular discordance on another series, thousands of feet thick, which Noble (1934) has suggested may be related to the Upper Precambrian formations in the tilted fault blocks of the eastern part of the Grand Canyon. These formations of the Death Valley region consist of sandstone, shale, and carbonate beds, as free from metamorphism as the younger series that leads up to *Olenellus*. The structural discordance, however, is emphatic, and largely on this basis a number of geologists have chosen the base of the Noonday dolomite as the base of the Cambrian system. The reasoning, presumably, has been about as follows: Development of an erosion surface across the strongly tilted and faulted sedimentary series in the Death Valley region and in the Colorado Plateau, with complete removal of these formations in a wide intervening area, indicates long-continued emergence of western North America. Re-submergence and renewed sedimentation, with progressive onlap eastward, marks a major physical change which logically may be taken as the start of a new geologic period and era. Those who have held this view probably explain the lack of fossil record through a large thickness of the younger section by a combination of circumstances. Conditions in this region may have been un-

favorable for kinds of living forms that would leave a record, or at least for preservation of any record. The last point applies logically to the Noonday dolomite and the Stirling quartzite, both of which have lithology notably unfriendly to the fossil hunter. The Johnnie formation, on the other hand, consists in large part of thin shale, sandstone, and scattered carbonate beds, which theoretically should be favorable for preservation of fossils. It may be urged, however, that in most early Cambrian sections fossils are not plentiful at best, and that not enough intensive work has been done in the region to warrant our writing off the Johnnie as a barren formation. This argument of course is largely negative.

Let us look at the sections farther west. In the Panamint Range, according to Hopper (1947), there is no Noonday dolomite, and a much thinned Johnnie formation rests on tilted strata that presumably are Precambrian. In this part of the region, therefore, the floor on which deposition of the higher series began was very irregular. However, no evidence has been found to suggest abrupt relief—the Johnnie beds contain no coarse-grained deposits.

The Inyo and Silver Peak ranges display the sections made classic by the early work of Turner (1909) and Walcott (1908). The Silver Peak series is of particular interest because fossils in relative abundance range through so large a part of its thickness. H. E. Wheeler, after a recent visit to Walcott's Waucoba Springs locality (1948), pronounced the section too complex structurally to be used as a satisfactory standard without more comprehensive field studies. However, Knopf and Kirk (1918) found at Andrews Mountain a more complete section, apparently free from repetition by faulting. Kirk states that the total thickness is 7000 feet or more, of which about a fifth consists of carbonate beds. According to Walcott the genus *Olenellus* ranges through nearly 5000 feet, and other forms, including the trilobite *Holmia* and the brachiopod *Obolella*, reach at least 1200 feet lower. Abundant forms reported by Walcott and Kirk as "corals" (Knopf and Kirk, 1918, p. 31)—probably archaeocyathids—suggest reef structure. In short, the thick deposit appears to be almost entirely of marine origin.

The Silver Peak beds overlie the Campito sandstone, a fine-grained crossbedded sandstone, some of it quartzitic, typically in thick beds. Even in this sandstone Kirk reports numerous markings which he diagnosed as tracks possibly made by trilobites. Walcott (1908, p. 12) reported from some Nevada localities, in the Prospect Mountain quartzite, trails that he interpreted as marks made by trilobites.

On both physical and organic evidence, the Wood Canyon formation is logically correlated with the Silver Peak beds. Wheeler draws the base of the Cambrian at the lowest horizon from which *Olenellus* has thus far been reported, about 350 feet above the base of the Wood Canyon formation. However, in the evidence presented by Kirk and Walcott there is a suggestion that arthropods—genus unknown—lived during deposition of the Campito sands, in a section much more marine in character than corresponding sections near Death Valley. Although we might assume that marine fossils never will be found below the base of the Wood Canyon beds, their absence could mean simply that the environment of deposition was inhospitable for life that existed at that time. It would indeed be remarkable to find well preserved fossils in the Stirling quartzite in which the thick beds, abundant cross beds, and commonly conglomeratic texture suggest turbulent, perhaps deltaic conditions under which remains of living forms, even if they were present, would have had little chance to be preserved. Wheeler himself (1947) notes that at Frenchman Mountain he was able to find *Olenellus* only in a zone 32 feet thick, 80 feet above the base of the green shale and 390 feet above the basal unconformity. Yet there he pronounces (with good reason) all of these barren beds Lower Cambrian, whereas he relegates to the Precambrian a smaller thickness of the Wood Canyon formation in the Nopah Range, solely on the ground that search in this part of the section has not as yet revealed *Olenellus*.

Wheeler and Beesley (1948) represent diagrammatically the concept, which has long been widely accepted, of progressive onlap from a basin of deposition across an adjacent land. The land mass shed sediments into the basin, and was at last covered

through lowering by erosion combined with rise of the sedimentary column. Beds that carry typical Lower Cambrian fossils at Frenchman Mountain and near the mouth of the Grand Canyon look almost identical in lithology and in their relation to the basal unconformity, to beds in the eastern part of the Grand Canyon that carry a Middle Cambrian fauna. Moreover, we can endorse the suggestion of Wheeler and Beesley that near Death Valley beds lower than the Wood Canyon formation—say in the lower part of the thick Stirling quartzite—were deposited somewhat earlier than the Lower Cambrian beds at Frenchman Mountain. But classification of the Stirling quartzite as Precambrian requires (1) acceptance of *Olenellus* as the *sine qua non* in determining Lower Cambrian age, and (2) assumption that all diagnostic fossils in this part of the section have been found. It may be suggested, in opposition to the "*Olenellus* school," that trilobites other than *Olenellus* may play a part in the diagnosis of beds as Lower Cambrian. Walcott (1915) reported that at Barrel Spring, near Silver Peak, he found the genera *Nevadina* and *Holmia* at considerably lower horizons than *Olenellus*. Still other fossil forms conceivably may be championed as of some importance in this matter, in addition to certain physical criteria to be mentioned presently.

It is by no means assured that the Johnnie and Noonday formations have the simple physical relationship to higher formations that ordinarily are suggested in regional diagrams. Knopf and Kirk (1918) report that in the Inyo region deep erosion preceded deposition of the Campito sandstone, with complete removal locally of a thick formation that may correlate with the Johnnie deposits. Moreover Hazzard (1938) cites some evidence for unconformity at the base of the Stirling quartzite in the Nopah Range; beds with contrasting lithologies appear below the contact at outcrops not far separated, and there is a suggestion of slight angular divergence between the upper Johnnie and the lower Stirling beds. We are reminded that the contact between the Cambrian and the Belt series of Montana was thought to be an inconspicuous unconformity until regional studies demonstrated a major, even though gradual, angular dis-

cordance. In the structurally broken Death Valley region there is less opportunity for such a regional check.

It is quite possible, then, that the Noonday and Johnnie formations belong to an earlier episode of sedimentation, which was followed by crustal warping, erosion, and renewed basining. On the other hand the Stirling quartzite appears to have initiated a consistent chapter of sedimentation which was remarkably uniform over a wide region. As Wheeler notes, the name Prospect Mountain quartzite (or sandstone) may well be applied to the initial deposit of this episode, from eastern California, through southern and central Nevada, western Arizona, western and northern Utah, to southeastern Idaho. The several names Campito, Stirling, Tapeats, Prospect Mountain, Brigham have been applied to this highly siliceous accumulation, which presumably represents long-continued subaerial decay on a large landmass. Encroachment of the sea brought about assortment of these weathering products, and deposition, with progressive onlap, of the quartz sands and gravels, followed by thin beds of fine-grained clastics with sporadic carbonate layers, muds that formed greenish shales, and finally a thick carbonate section. It would be difficult to find, in the entire geologic column, a more ideal succession of strata to be termed a system. And surely the organic evidence is equally satisfactory. Fossils that have long been accepted as Lower Cambrian have been found in shaly beds near the top of the Prospect Mountain quartzite (Walcott, 1892) and equivalent units. To exclude from the Cambrian the bulk of this formation, which because of its lithology is logically barren of fossils, is to ignore completely the cogent physical relationships between this clastic deposit and the beds above it.

Therefore I would include in the Cambrian system all of the Prospect Mountain quartzite and its lithologic correlatives. This major unit in many ways constitutes an ideal basal element of the system. However, there is not yet a firm basis for drawing a definite lower boundary of the Cambrian in the Death Valley region. I believe that at present the Johnnie formation and the Noonday dolomite, together with the Deep Springs formation and the Reed dolomite of the Inyo

region, should be carried under the heading "age unknown." Designation of these units as definitely Precambrian does not seem warranted by the evidence now available.

Literature describing relationships of the Windermere series to lower and higher stratigraphic units in the northern Rocky Mountains suggests conditions very similar to those in the Basin and Range province discussed above. However, analysis of the problem for the northern Cordillera will be left to students who have firsthand acquaintance with that region.

#### LITERATURE CITED

- DEISS, CHARLES. *Cambrian geography and sedimentation in the central Cordilleran region.* Bull. Geol. Soc. Amer. **52**: 1085-1116. 1941.
- EARDLEY, A. J. *Paleozoic Cordilleran geosyncline and related orogeny.* Journ. Geol. **55**: 309-342. 1947.
- HAZZARD, J. C. *Paleozoic section in the Nopah and resting Springs Mountains, Inyo County, California.* Journ. Mines and Geol. **33**: 273-339. 1938.
- HOPPER, R. H. *Geologic section from the Sierra Nevada to Death Valley, California.* Bull. Geol. Soc. Amer. **58**: 393-432. 1947.
- KNOFF, A., and KIRK, E. *A geologic reconnaissance of the Inyo Range and the eastern slope of the southern Sierra Nevada, California.* U. S. Geol. Surv. Prof. Paper 110: 23-31. 1918.
- McKEE, E. D. *Stratigraphy and ecology of the Grand Canyon Cambrian.* Carnegie Inst. Washington Publ. 563, pt. 1. 1945.
- NOBLE, L. F. *Rock formations of Death Valley, California.* Science **80**: 173-178. 1934.
- NOLAN, T. B. *A late Paleozoic positive area in Nevada.* Amer. Journ. Sci. (5) **16**: 153-161. 1928.
- . *Notes on the stratigraphy and structure of the northwest portion of Spring Mountain, Nevada.* Amer. Journ. Sci. (5) **17**: 461-472. 1929.
- TURNER, H. W. *Contribution to the geology of the Silver Peak quadrangle, Nevada.* Bull. Geol. Soc. Amer. **20**: 223-264. 1905.
- WALCOTT, C. D. *Systematic list of fossils of each geological formation in the Eureka District, Nevada.* U. S. Geol. Surv. Mon. **20**: 319-321. 1892.
- . *Cambrian geology and paleontology.* Smithsonian Misc. Coll. **53**: 12, 185-189, 199. 1908.
- . *The Cambrian and its problems: Problems of American geology:* 205-207. 1915.
- WHEELER, H. E. *Base of the Cambrian system.* Journ. Geol. **55**: 153-159. 1947.
- . *Late pre-Cambrian-Cambrian stratigraphic cross section through southern Nevada.* Univ. Nevada Bull. **42**: no. 3. 1948.
- and BEESLEY, E. M. *Critique of the time-stratigraphic concept.* Bull. Geol. Soc. Amer. **59**: 75-86. 1948.



PALEONTOLOGY.—*Remains of Devonian fishes from Texas.* DAVID H. DUNKLE, U. S. National Museum,<sup>1</sup> and JOHN A. WILSON, University of Texas.

Two papers on Paleozoic rocks of central Texas (Cloud, Barnes, and Warren, 1945, and Cloud and Barnes, 1948) include description of rocks of uncertain age containing bones which are herein identified by Dunkle as Upper Devonian. First mention of the bones is found in Cloud, Barnes, and Warren (1945, p. 174): "A slab of conodont- and bone-bearing calcareous and phosphatic rock (16-T-33D)<sup>2</sup> was found and collected by Barnes and Warren while they were mapping the Ordovician-Carboniferous contact near Elm Pool, Blanco County, on May 14, 1942." Somewhat later "three other localities were found at which similar conodont- and bone-bearing rock occurs: 16T-2-25B, 16T-1-32C, and 16T-2-27<sub>1</sub>A."<sup>3</sup> Conodonts from the original bone-bearing slab were determined by W. H. Hass (memorandum to H. D. Miser dated March 2, 1945) to be of both "Mississippian" and "Devonian" types. Macrofossils from the third locality were recognized positively by Dr. G. A. Cooper (letter to Cloud, February 27, 1945) as of earliest Mississippian age. The conclusion drawn by Cloud, Barnes, and Warren (1945) was that the conodonts and macrofossils (invertebrates) dated the rocks in question as earliest Mississippian.

The extensive report of Cloud and Barnes (1948, dated 1946), "The Ellenburger Group of Central Texas," contains additional information concerning the bone-bearing beds. Cloud and Barnes (1946) elevate the Ives breccia of Plummer (Bullard and Plummer, 1939) to formational rank. The relationship of the "bone bed" to the Ives breccia is described (Cloud and Barnes,

1946, pp. 46-47) as follows: "Locally, the breccia seems to grade laterally into or to overlie or underlie a reddish-brown, olive-gray, brownish, or yellowish impure limestone or phosphatic rock containing conodonts, fragments of bones, phosphatic pellets, and sand grains. Apparently more than one "bone bed" is involved, but relationships are obscure."

The purpose of this paper is to present what small amount of information is obtainable from the bones and the implications that can be drawn from them.

#### *Dinichthys* cf. *terrelli* Newberry

The recognizable remains include six fragments of the dermal armor of a large placodermatous fish. Four of these six broken and eroded pieces of bones, all from locality 16T-2-33D, can be readily identified as characteristic portions of arthrodiran plates, a fragmentary left paranuchal (Fig. 1), a left suborbital (Fig. 2), a left inferognathal (Fig. 3), and a right interolateral (Fig. 4). Comparative examinations prompt provisional reference of the four to a form closely allied to the well-known brachythoracine *Dinichthys terrelli* Newberry. The present materials are illustrated imposed on outlines and appropriate sections of complete elements of the latter species. For the purpose of this note further description is unnecessary.



FIG. 1.—*Dinichthys* cf. *terrelli* Newberry (U.T.-B.E.G. no. 40100): Left paranuchal plate fragment in internal aspect. Reproduction approx.  $\times 25$ .

<sup>1</sup> Published by permission of the Secretary, Smithsonian Institution.

<sup>2</sup> The Bureau of Economic Geology, University of Texas, uses a system of locality numbers in which each of the 254 counties of the State is assigned a number, Blanco County being number 16. The "T" stands for Texas, and the remainder of the number designates the position within a county as recorded on aerial photographs for central Texas.

<sup>3</sup> Locality descriptions are given in detail in Cloud, Barnes, and Warren (1945) and in Cloud and Barnes (1948).

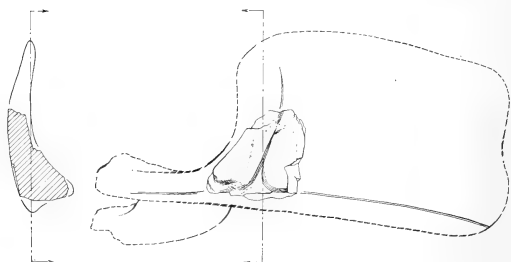

FIG. 2.—*Dinichthys* cf. *terrelli* Newberry (U.T.B.E.G. no. 40100-3): Left suborbital plate fragment in transverse section and lateral aspect. Reproduction approx.  $\times 2/5$ .

It is not possible here to make more than a tentative identification. This fact is not due alone to the fragmentary nature of the material but must be coupled with various questions concerning the basic status of *Dinichthys terrelli* and its relatives. *D. terrelli*, as now recognized, is restricted to the Upper Devonian Ohio Shales formation. It, with the species *intermedius* and *curtus*, from the same strata, comprise a series of advanced *Coccosteus*-like forms, which by virtue of the numerous modifications discussed by Dunkle and Bungart (1946) is quite distinct from all the other so-called dinichthyids of the Ohio Shales (that is, *Dinichthys herzeri*, *Gorgonichthys*, *Heintzichthys*, and *Holdenius*). Though meagerly elaborated by Orvig (1951) it is possible that some of the same features noted by Dunkle and Bungart (1946) motivated Stensio's (1945) separation of the brachythoracines into the orders *Coccosteiformes* and *Pachyosteiformes*.

Thus, regardless of the taxonomic value placed on the recognized differences, it is necessary that all *Dinichthys* species from North America be examined to ascertain with which group each is related. Until the task is completed, these materials from Texas can have little use in definitive stratigraphic correlations.

#### Arthrodira, gen. and sp. undet.

Two fragments (Fig. 5) (from locality 16T-1-32C), presumably of the same identity, are unique in the possession of extremely large denticles arranged in a single row along one of their margins. Both specimens are too fragmentary for a complete description. They are, however, relatively low asymmetrical structures with robust elliptical cross sections. The teeth are recurved, slightly compressed, indicated to be variously spaced and to vary in height from one-half to one-third the depth of the supporting

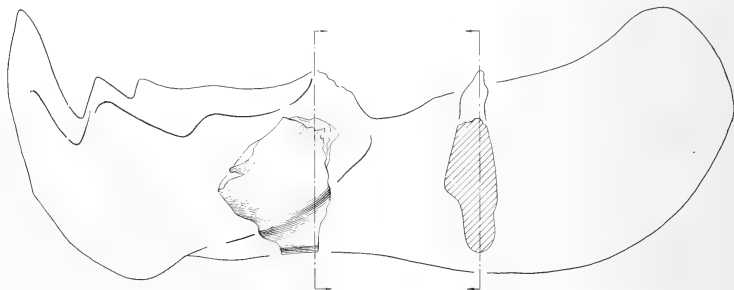

FIG. 3.—*Dinichthys* cf. *terrelli* Newberry (U.T.B.E.G. no. 40100-2): Left inferognathal plate fragment in lateral aspect and transverse section. Reproduction approx.  $\times 2/5$ .

bone. They appear as projections from the bone, becoming dense and containing a pulp cavity distally.

The gross histology and over-all construction of the specimens suggest an arthrodiran mandible with teeth, rather than an ichthyodorulite. Among arthrodires with large teeth and long, low mandibles are the upper Devonian genera *Diplognathus* and *Tracheosteus*. These latter, unfortunately, are also incompletely known and it seems best to postpone identification of the Texas material.

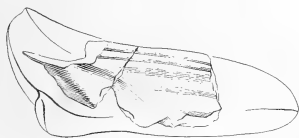

FIG. 4—*Dinichthys* cf. *terrelli* Newberry (U.T.-B.E.G. no. 40100-1): Right interolateral plate fragment in anterolateral aspect. Reproduction approx.  $\times 2/5$ .

#### DISCUSSION

If later work shows that *Dinichthys terrelli* and its relatives are restricted to the Upper Devonian Ohio Shales formation, then the *D. cf. terrelli* fragments from Texas do have significance stratigraphically. That they occur with Mississippian invertebrates and conodonts seems to be proved. Where they came from, however, has not been mentioned in the literature. If a short-lived sea of Upper Devonian age occupied the area just prior to Ives breccia time and

deposited a thin mantle of soft easily erodible material (that is, shale) in which the bones of the placoderms and the Devonian conodonts would be the most resistant structures, then a source for the reworked bones and conodonts would be available. This hypothesis would not seem to conflict with the reasoning of Cloud and Barnes (1948, pp. 48-49) if the long period of weathering necessary to free the chert of the Ives breccia is assumed to have taken place prior to the invasion of the supposed sea.

#### REFERENCES

- BULLARD, F. M., and PLUMMER, F. B. *Paleozoic section of the Llano uplift*. Guide to the Geologic Excursions Sponsored by West Texas Geol. Soc., Fort Worth Geol. Soc., Texas Acad. Sci., and Univ. Texas: 1-20, 6 illus. 1939. (Mimeographed.)
- BARNES, V. E., CLOUD, P. E., JR., and WARREN, L. E. *The Devonian of central Texas*. Univ. Texas Publ. 4301: 161-177, pls. 9-10, figs. 42-46. 1943.
- . *Devonian rocks of central Texas*. Bull. Geol. Soc. Amer. 58: 125-140, 1 pl., figs. 1-7. 1947.
- CLOUD, P. E., JR., and BARNES, V. E. *The Ellenburger group of central Texas*. Univ. Texas Publ. 4621: 1-473, 44 pls., 8 figs., 3 tables. 1948 (dated 1946).
- DUNKLE, D. H., and BUNGART, P. A. *The antero-supragnathal of Gorgonichthys*. Amer. Mus. Nov. 1316: 1-10, 4 figs. 1946.
- ORVIG, T. *Histologic studies of placoderms and fossil elasmobranchs*. Ark. Zool., ser. 2, 2(2): 321-454, pls. 1-8, figs. 1-22. 1951.
- STENSIO, E. *On the heads of certain arthrodires, II*. Kungl. Svenska Vet.-Akad. Handl., ser. 3, 22(1): 1-70, figs. 1-14. 1945.

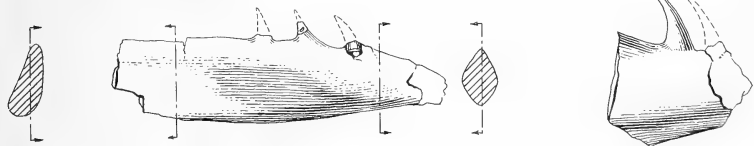

FIG. 5.—*Arthrodira*, gen. and sp. undet. (U.T.B.E.G. no. 40101): Fragments of dentate mandibular elements in transverse sections and lateral aspects. Reproduction approx.  $\times 9/10$ .

PALEONTOLOGY.—Notes on *Texacrinus*. HARRELL L. STRIMPLE, Bartlesville, Okla. (Communicated by Alfred R. Loeblich, Jr.)

The author was first aware of the presence of crinoids in the Francis shale of southeastern Oklahoma with the description of *Oklahomacrinus loeblichii* Moore (1939). The specimen involved was somewhat fragmentary and did not indicate particularly lucrative collecting possibilities. Richard Alexander, at present a student at the University of Oklahoma, called my attention to the potentialities of the horizon as exposed in the brick pit just south of Ada, Okla., which is the type locality of *O. loeblichii*. Before an expedition was arranged, he and Allen Graffham, of Carter Oil Co., explored the exposed zones more thoroughly. Mr. Graffham was cognizant of special techniques needed to remove shale blocks and subsequently to expose the specimens. One fairly large pocket proved to be especially prolific in crinoid calices and crowns. It was somewhat comparable to famous crinoid "nests" of Crawfordsville, Ind., Le Grand or Gilmore City, Iowa, or Huntsville, Ala.; however, there was no associated limestones, and preservation was therefore not so perfect. Most of the material available for study was collected individually and collectively by Allen Graffham, Richard Alexander, Claude Bronaugh, and the author. Considerable time and effort have been spent in excavating the shale blocks, especially from the large colony. A thin layer of carbonaceous vegetal material marks the top of the 3- to 4-inch crinoid zone and a jumbled mass of isolated columnals and shells mark the bottom. Other smaller "nests" have been discovered at somewhat lower horizons, but the specimens are more difficult to prepare.

In the present paper an effort is made to record several new species from the Francis shale which are assigned to *Texacrinus* Moore and Plummer (1940), as well as two species from lower and higher horizons. Heretofore only one species had been described, *T. gracilis* Moore and Plummer (1940), which is the genotype species. The holotype and only specimen known at that time was a magnificent crown from the Des Moines formation of Texas, but the cup is somewhat distorted owing to lateral compression and

the exact nature of the base is not known. It was interpreted, and probably correctly, by these authors that the cup had a slightly depressed base. The author has also collected a crown from the same horizon in Texas but unfortunately the lower portion of the cup is missing and if present would have been compressed in the same manner as the holotype.

A new form from the Des Moines of Oklahoma is presented as *T. associatus*, n. sp. It has a broader cup with a wider basal area than normal for the genus.

Three new species are presented from the Missouri: *T. interruptus*, *T. irradiatus*, and *T. compactus*. The first two are robust, with unusually large columnals, relatively high dorsal cups, and IBB entirely covered by the proximal columnals. *T. interruptus* is distinctive in having circular depressions at the angles of the plates and strong tumidity of cup plates. The presence of these depressions, and subsequently raised areas along the sutures, is considered by the author and others as a significant specialization which is in some instances of generic importance. *T. compactus* has an unusually small stem and a more compact cup than the other species from the Francis shale.

One species is described as *T. progressus* from the Virgil series of northeastern Oklahoma. It discloses a progressive step toward elimination of the anal plates from the dorsal cup and is the only known representative of the genus to show any appreciable change in this respect.

The author believes there is a close affinity to *Haerteocrinus* Moore and Plummer (1940), but this matter will be discussed at length in a later paper.

Genus *Texacrinus* Moore and Plummer

*Texacrinus interruptus*, n. sp.

Fig. 8

Dorsal cup has the form of a medium, basally impressed globe. All sutures are impressed, and deep round depressions are found at the angles of the plates. Infrabasals (IBB) are entirely within the basal concavity and are covered by the proxi-

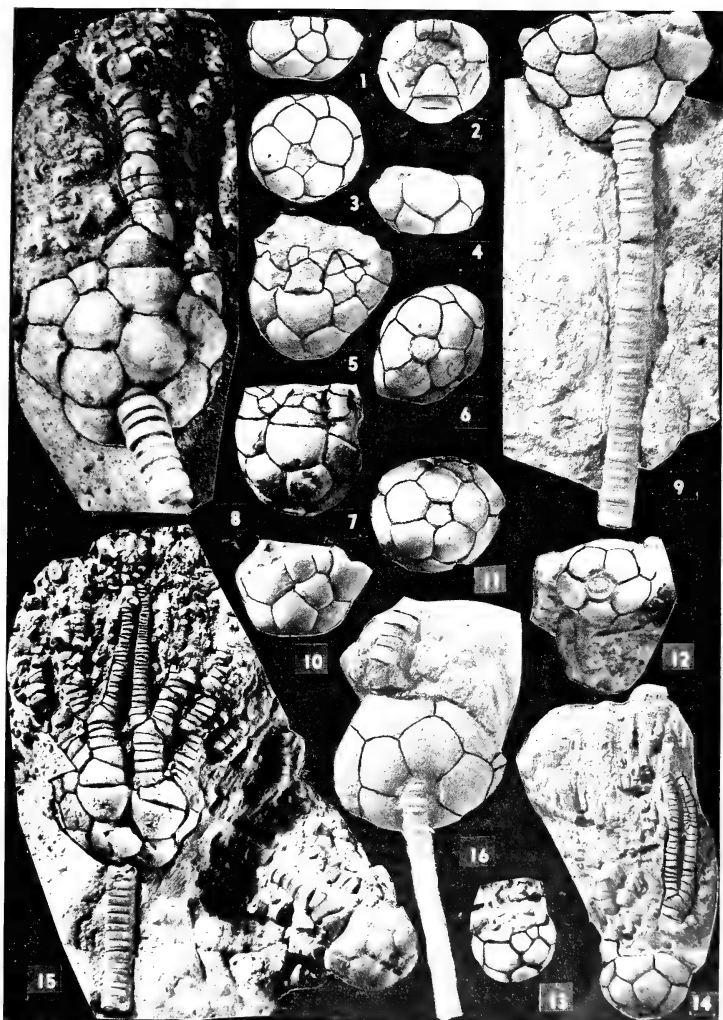

FIGS. 1-4.—*Texacrinus associatus*, n. sp.: Holotype from posterior, summit, base, and anterior  $\times 2$ . FIGS. 5-7.—*Texacrinus progressus*, n. sp.: Holotype from left posterior, base, and right anterior  $\times 2$ . FIG. 8.—*Texacrinus interruptus*, n. sp.: Holotype from the right posterior,  $\times 2$ . FIGS. 9, 12-15.—*Texacrinus irradiatus*, n. sp.: 9, Large paratype from right posterior,  $\times 1.3$ ; 12-14, young paratype from base,  $\times 2.7$ , posterior and anterior,  $\times 2$ ; 15, holotype from right posterior (a specimen of *Arsinocebus*, n. sp. is also shown),  $\times 1.2$ . FIGS. 10, 11, 16.—*Texacrinus compactus*, n. sp.: 10, 11, Holotype from posterior and base,  $\times 2$ ; 16, paratype from anterior,  $\times 2.3$ .

mal columnals. Basals (BB) are five large tumid plates which curve strongly out of the depressed base and form an appreciable portion of the lateral calyx walls. Radials (RR) are five medium plates which are tumid and have articulating facets which do not fill their distal faces. Three tumid anal plates occupy the posterior interradius (post. IR). The radianal (RA) is unusually large, rests obliquely on the upper surface of post. B, and supports anal X and RX to the right and left above. Anal X is considerably larger than RX but the upper surfaces of the two plates form a common plane, above the distal extremities of the dorsal cup.

Complete arm structure is not known for this species. Axillary first primibrachials (PBrBr) are present in several rays. They are low, tumid elements. The following SBrBr are rather large and cuneiform, with well-rounded exteriors.

Sixteen or more columnals are preserved and show the unusually robust nature of the stem. A thin small columnal is succeeded by, and sharply defined from, a large thick columnal.

*Measurements (in mm).—*

	<i>Holotype</i>
Width of dorsal cup	17.5
Height of dorsal cup	10.5
Diameter of expanded proximal columnals	3.8
Length of l. post. B*	7.3
Width of l. post. B*	6.0
Length of l. post. R*	5.0
Width of l. post. R*	7.9
Length of suture between BB	3.7
Length of suture between RR	2.8

\* Along surface curvature.

*Remarks.*—This species is more comparable to *T. irradiatus* than other described species and is readily distinguished by the strong tumidity of the cup plates, sharp definition between the alternately expanded columnals, and depressions at the angles of the cup plates.

*Occurrence and horizon.*—Upper part of the Francis shale, Missouri series, Pennsylvanian; section 4, T. 3 N., R. 6 E., brick pit south of Ada, Okla.

*Types.*—Holotype collected by the author. To be deposited in the U. S. National Museum.

***Texacrinus irradiatus*, n. sp.**

Figs. 9, 12-15

Dorsal cup is in the form of a medium, basally impressed bowl. IBB are five small plates confined to the basal concavity and are almost entirely covered by the proximal columnals. BB are five large plates which participate strongly in the

lateral walls of the calyx. RR are five large pentagonal plates. The outer surface of the RR continue for a short distance into the interarticulating areas so that the articulating facets do not occupy the full width of the plates. Three large anal plates are present in the post. IR. RA covers the entire upper surface of post. B and is followed above by anal X to the left and RX to the right. Anal X is the larger of the two; however, it forms a common plane with RX. The latter plate occupies a considerably higher position in relation to the basal plane of the cup. All sutures between cup plates are mildly to sharply impressed.

Thirty cuneiform arms are indicated. First PBrBr are axillary in all rays and are low wide elements. Second bifurcation takes place on or about the fifth SBrBr in all rays. Thereafter the outer rays remain unbranched, but a second dichotomy takes place in the inner rays.

The column is round and is composed of alternately expanded columnals. No evidence of cirri has been found. Tegmen is unknown. Crown and column are devoid of ornamentation.

*Measurements (in mm).—*

	<i>Holotype</i>	<i>Large figured paratype</i>	<i>Small figured paratype</i>
Width of dorsal cup	21.4*	30.0*	7.1
Height of dorsal cup	9.8	15.0	5.0
Diameter of expanded columnals	4.2	6.5	2.3
Width of r. ant. B†	6.5	10.0	4.4
Length of r. ant. B†	7.8	10.2	3.0
Width of r. ant. R†	10.0	12.0	4.5
Length of r. ant. R†	6.5	7.4	2.6
Length of arms (as preserved)	33.2	—	18.3
Length of suture between BB	6.0	6.9	2.2
Length of suture between RR	4.5	4.7	1.8

\* Mildly distorted due to lateral compression.

† Along curvature of plates.

*Remarks.*—This species is the commonest representative of the genus found in the Francis shale. It is more robust than *T. interruptus*, and comparison is given under description of that species. The small figured paratype is obviously a young representative of the species in that the column remains proportionately large. The arms of the young specimen are more comparable to those of *T. gracilis* in their delicate appearance.

*Occurrence and horizon.*—Upper part of the Francis shale, Missouri series, Pennsylvanian; section 4, T. 3 N., R. 6 E., brick pit south of Ada, Okla.

*Types.*—Holotype and figured paratypes collected by Allen Graffham. To be deposited in the U. S. National Museum.

**Texacrinus compactus, n. sp.**

Figs. 10, 11, 16

This species is fairly abundant in the Francis shale and is characterized by the small compact nature of the cup and the comparatively small column. A complete crown has not been found but the dorsal cup is well represented and portions of the arms are known.

Dorsal cup is in the form of a medium, basally impressed truncated cone. IBB are almost entirely covered by the proximal columnals but their outer apices are visible in the shallowly impressed basal area. BB are five rather elongated plates. RR are five pentagonal plates with width slightly greater than length. There are three plates in the post. IR; RA is the largest and separates anal X from post. B, anal X is somewhat larger than RX which is to the right and forms a common plane with anal X in upper extremities.

Column is small and tapers slowly. Although the columnals are alternatingly expanded there is not the sharp differentiation between small and large segments as found in other species of the genus from the Francis shale.

*Measurements (in mm).—*

	<i>Holotype</i>	<i>Figured paratype</i>
Width of dorsal cup .....	12.3	13.5
Height of dorsal cup .....	6.7	5.8
Diameter of expanded proximal columnal .....	1.7	1.9
Width of r. ant. B* .....	5.0	5.8
Length of r. ant. B* .....	5.0	5.8
Width of r. ant. R* .....	6.0	6.4
Length of r. ant. R* .....	4.0	4.2
Length of suture between BB .....	2.5	2.9
Length of suture between RR .....	1.8	2.0

\* Along surface curvature.

*Remarks.*—The compact nature of the dorsal cup and proportionately small stem distinguish this from other described species.

*Occurrence and horizon.*—Upper part of the Francis shale, Missouri series, Pennsylvanian; section 4, T. 3 N., R. 6 E., brick pit south of Ada, Okla.

*Types.*—Holotype collected by Richard Alexander. Figured paratype collected by the author. To be deposited in the U. S. National Museum.

**Texacrinus progressus, n. sp.**

Figs. 5-7

The dorsal cup has the form of a moderately high truncated globe. There are five IBB in the narrow basal invagination which extend slightly beyond the proximal columnal. Five BB are

elongated elements forming a large portion of the outer cup walls. Five RR are wider than long. The outer surfaces carry into the interarticulating areas for a short distance along the sutures. Plates of the post. IR have an unusual arrangement. RA is large and reaches across the entire upper surface of post. B to make a broad contact with l. post. R. Anal X. is moderately large and extends well above the normal height of the cup. RX is small and is entirely separated from RA by post. R. Distal faces of anal X and RX form a common plane and are each followed by single tube plates of equal size and appearance.

All first PBrBr are axillary. They are mildly constricted in midsection in somewhat the same manner as those of *Apographiocrinus typicalis* Moore and Plummer (1940). They are of unequal length. Only a few SBrBr are preserved and were apparently cuneiform.

Tegmen is unknown. Proximal columnals are round, alternatingly expanded and well crenulated.

*Measurements (in mm).—*

	<i>Holotype</i>
Width of dorsal cup .....	12.3 *
Height of dorsal cup .....	7.0
Diameter of expanded proximal columnal .....	2.0
Width of r. ant. B* .....	5.7
Length of r. ant. B* .....	6.0
Width of r. ant. R* .....	6.4
Length of r. ant. R* .....	4.2
Length of suture between BB .....	3.0
Length of suture between RR .....	2.5

\* Along surface curvature.

*Remarks.*—The general appearance of this species is more comparable to *T. compactus* than to other described species. *T. progressus* is readily distinguished by the more advanced arrangement of the anal plates and the slightly elongated axillary PBrBr.

*Occurrence and horizon.*—Nelagony formation, about 35 feet below the Wildhorse limestone member, Virgil series, Pennsylvanian; NW ¼ section 21, T. 22 N., R. 10 E., Osage County, Okla., about 15 miles west of Skiatook.

*Types.*—Holotype collected by Richard Alexander. To be deposited in the U. S. National Museum.

**Texacrinus associatus, n. sp.**

Figs. 1-4

Dorsal cup has the form of a low basally impressed globe. All cup plates are mildly tumid principally due to the impressed sutures. Five IBB form a pentagonal disk at the bottom of the

shallow basal concavity, and are visible beyond the columnar scar. Five BB form a broad basal plane and curve upward to participate in the lateral cup walls. Five RR are wide pentagonal plates. The outer surfaces of RR extend into the interarticulating areas but not in a pronounced manner. Distinctive characters of the articulating facets are the unusually large outer areas where strong outer marginal ridges are found. Ligamental pit furrows are pronounced and transverse ridges are sharp though not prominent. Muscle areas are rather small and slope slightly outwardly.

Three anal plates are present in the post. IR. RA is the larger and has firm contact with I. post. R, anal X, RX, r. post. R, r. post. B and post. B. Anal X is rather small and extends above the distal extremities of the cup. RX is small and forms a common upper plane with anal X.

Proximal columnals are not present but the cicatrix is well defined. Strong crenulations mark the perimeter of the scar and the lumen appears to be rather large and pentalobate.

*Measurements (in mm).—*

	<i>Holotype</i>
Width of dorsal cup.....	11.7
Height of dorsal cup.....	5.1
Diameter of columnar scar.....	2.0
Width of r. ant. B*.....	6.0
Length of r. ant. B*.....	6.0
Width of r. ant. R*.....	7.0
Length of r. ant. R*.....	4.2
Length of suture between BB.....	2.2
Length of suture between RR.....	1.7

\* Along surface curvature.

*Remarks.*—The broad basal plane and low dorsal cup serves to distinguish *T. associatus* from other known species of the genus.

*Occurrence and horizon.*—Oologah limestone (perhaps equivalent to the Altamont limestone of Kansas), Des Moines series, Pennsylvanian; Chandler Materials Company quarry, east of Tulsa, Okla.

*Types.*—Holotype collected by the author. To be deposited in the U. S. National Museum.

#### REFERENCES

- MOORE, R. C. Journ. Sci. Lab., Denison Univ. Bull. 39: 261-265. 1939.  
 ——— and PLUMMER, F. B. Univ. Texas Publ. 3945: 143-146, pl. 15, fig. 4, pl. 21, fig. 5. 1940.

ENTOMOLOGY.—*The Ethiopian genera of Sarginae, with descriptions of new species.* MAURICE T. JAMES, State College of Washington.

The subfamily Sarginae forms a more uniform and homogenous group of flies, over a wide part of the earth's surface, than do the other subfamilies of Stratiomyidae. Collections from the different continents and from major island areas appear surprisingly similar to one another. The wide distribution of such genera as *Microchrysa*, *Ptecticus*, and *Sargus* s.s. is noteworthy. Yet speciation is occurring actively in some areas, and major geographic areas may have their endemic genera. The Ethiopian Region is no exception in this respect.

Eight valid genera have previously been recorded from the Ethiopian Region. These consist of the widely distributed *Sargus*, *Ptecticus*, *Microchrysa*, *Cephalochrysa*, and *Chloromyia* and the three endemic genera *Sagaricera*, *Paraptecticus*, and *Otochrysa*. The last mentioned genus is unknown to me except from its description (Lindner, 1938b, p. 15). Consequently I am unable to place it in the key or to remark further concerning its status. *Parasargus*, proposed by Lindner

(1935, p. 300) for a new species, *P. africanus*, was later reduced by that author (Lindner, 1938b, pp. 13, 14) to the status of a subgenus of *Microchrysa*, and the generotype synonymized with *M. stigmatica* Enderlein. The genus *Chrysochroma* (generotype *Musca bipunctata* Scopoli) is at most a subgenus of *Sargus*, in which the ocelli are equidistant from one another. Many species previously referred to *Chrysochroma* belong in *Cephalochrysa* or other genera of Sarginae. *Chrysochromoides* Brunetti (1926, p. 135), proposed for *C. micropunctata* Brunetti 1926, is unknown to me; Brunetti says it differs from *Chrysochroma* only in the simple third vein. It may be a valid genus or, on the other hand, a synonym of *Cephalochrysa* or *Sargus*.

#### KEY TO THE GENERA OF ETHIOPIAN SARGINAE

1. Eyes densely and distinctly pilose; lower squama well-developed, similar in form to the upper squama..... *Chloromyia*  
 Eyes bare; lower squama reduced, either transverse or with a relatively slender, straplike projection.....2



2. Second antennal segment, from the inner aspect, with a fingerlike process that protrudes deeply into the third.....3  
 Second antennal segment at most moderately convex apically.....4
3. Lower squama with a straplike process; first antennal segment longer than the second; frons of male reduced at its narrowest to less than the diameter of an ocellus; vein  $R_{2+3}$  arising beyond r-m by at least length of r-m.....*Sagaricera*  
 Lower squama transverse apically, without a straplike process; first antennal segment no longer than the second; frons of male, in Ethiopian species, at its narrowest broader than the ocellar triangle; vein  $R_{2+3}$  arising at or before r-m.....*Plecticus*
- 4.<sup>1</sup> Vein  $R_{2+3}$  arising between r-m and the apex of discal cell; lower squama transverse apically, without a straplike process, face distinctly protruding below, the oral margin prominent; nonmetallic species.....*Paraplecticus*  
 Vein  $R_{2+3}$  arising at or beyond the apex of the discal cell; lower squama with a straplike process; face not protruding below, the oral margin poorly developed; Ethiopian species at least partly metallic.....5
5. Abdomen short and broad, usually wider than the thorax and, measured to the apex of segment four, no longer than wide; eyes contiguous in the male and divided into definite zones of different sized facets; ocellar triangle equilateral.....6  
 Abdomen barely if any wider than the thorax, much longer than wide; eyes usually broadly separated (contiguous in male *Pedicellina*) and not divided into definite zones of different sized facets; ocellar triangle equilateral (*Chrysochroma*, some *Pedicellina*) or much longer than wide (typical *Sargus*)....*Sargus*
6. Discal cell small; posterior veins weak, evanescent toward wing margin; maximum width of anal cell equal to combined widths of two basal cells.....*Microchrysa*  
 Discal cell normal; posterior veins evident to wing margin; maximum width of anal cell but little greater than that of second basal cell, distinctly less than combined widths of two basal cells.....*Cephalochrysa*

Genus *Chloromyia* Duncan, 1837*Chloromyia tuberculata*, n.sp.

To my knowledge, this is the only black species of *Chloromyia* that has been described. It differs from the European species, *C. formosa* (Scopoli) (the genotype) and *C. melampogon* (Zeller), in that the frons of the female is tuber-

<sup>1</sup> *Otochrysa* Lindner (1938b, p. 15) should trace to this couplet, according to the description, but vein  $R_{2+3}$  arises beyond the apex of the discal cell, the only known species has a yellow body, and the postocular orbit of the female is strongly developed, keeled, and hairy.

culate, and from the described European, as well as the African species (*C. bella* (Loew), *C. caeligera* Lindner), in the color pattern of the legs.

*Female*.—Head black; frontal callus and face somewhat castaneous; upper corners of frontal callus prolonged into minute ivory triangles; a castaneous glabrous triangular area above frontal callus at midfrontal line. Frons moderately convex, with a prominent, though not clearly defined, tubercle a little less than halfway from anterior ocellus to frontal callus; this tubercle bisected, though not deeply, by the midfrontal suture. Frons coarsely punctate, the frontal callus, face, and postocular orbits similarly though less coarsely punctate, the punctures giving rise to silvery hairs. Postocular orbits well developed above, almost evanescent below. Eyes with moderately dense, moderately long black pile. Antenna structurally much as in *formosa*; the first segment shorter, however (subequal to the second), and the arista more slender basally and with one or two hairs at its extreme base; first and second segments shiny, black; flagellum reddish; arista blackish. Proboscis yellow.

Thorax black; humerus and a line from humerus to wing base ivory; mesonotum coarsely punctured, pleura less conspicuously so; pile silvery, short and strongly appressed on the dorsum, somewhat longer on the pleura. Coxae, trochanters, femora, and fore and mid tibia, except broadly at the knees, black; fore and mid tarsi brownish, paler at the bases of the basitarsi; hind tibia and tarsus yellowish, the basitarsus almost white, the apical half of the tibia and the apical two tarsomeres more brownish. Venation essentially as in *formosa*; membrane subhyaline, distinctly infuscated across the isthma and discal cell, paler at the base; veins brown, yellowish toward base. Squamae structurally as in *formosa*, pale yellow with whitish fringe. Halteres yellow, brownish on the stalk.

Abdomen black; densely though more finely punctured than on the mesonotum. Discs of second, third, and fourth terga, except basally, apically, and broadly laterally, with black (reddish in certain lights) appressed pile; terga otherwise and sterna with appressed silvery pile.

Length, 7.5 mm.

*Male*.—Eyes subcontiguous; postocular orbits wanting. Head with mostly black pile which,

together with that of the eyes, is much longer than in the female. Pile of mesonotum and scutellum long and largely erect. Abdomen shining violaceous dorsally, black ventrally, clothed entirely with silvery appressed pile. Otherwise, except sexually, as in the female.

*Types*.—Holotype, female, Mubende, Uganda, April 14, 1931 (H. Hargreaves); allotype, male, Kasenyi, Uganda, April 14, 1931 (Hargreaves); to be deposited in the British Museum (Natural History). Paratype, female, Kilimanjaro (W. L. Abbott), U. S. N. M. no. 23656.

*Variation*.—The female paratype has the antennae wholly yellow and has some blackish pile on the front; otherwise it agrees with the holotype.

#### Genus *Sagaricera* Grünberg, 1915

This genus was erected on the basis of the striking development of the antennal flagellum and was placed close to *Ptecticus* and *Chrysochroma*. The only species that has been referred to it is the genotype, *S. aenescens* Grünberg, described from a male (Grünberg, 1915, p. 63) and redescribed later from a female by Lindner (1938a, p. 68). Striking as this character is, I do not feel that it is a valid basis for differentiation, since another species, *Sargus analis* Macquart, referred to *Ptecticus* by Brunetti, is in other respects morphologically much closer to *Sagaricera* than to *Ptecticus*. I am therefore redefining *Sagaricera* on the basis of characters included in my generic key and am proposing the following new combination and synonymy.

#### *Sagaricera analis* (Macquart), n. comb.

*Sargus analis* Macquart, Dipt. Exot. 1: 204. 1838.  
*Ptecticus (sic!) analis* (Macquart), Brunetti, Rev. Zool. Afr. 14: 124. 1926.

*Ptecticus cinctifrons* Grünberg, Mitt. Zool. Mus. Berlin 8: 61. 1915; Lindner, Mitt. Deut. Ent. Ges. 8: 68. 1938; Lindner, Bull. Mus. Roy. d'Hist. Nat. Belg. 14: 6. 1938. (New synonymy.)  
*Ptecticus opalescens* Lindner, Deut. Ent. Zeit. 1934: 302. 1935. (New synonymy.)

In appearance this species resembles *S. aenescens* much more closely than it does any known species of *Ptecticus*. The male genitalia are of a type much different from that of any *Ptecticus* known to me.

Macquart's type came from an unknown locality, but M. E. Ségué kindly furnished me with a specimen compared with the type, and it is on this that the present synonymy is based.

#### Genus *Ptecticus* Loew, 1855

As restricted here, the Ethiopian species of *Ptecticus* seem to form a fairly homogenous group, although at least two very distinct types of male genitalia occur. The body is elongated and basically yellowish; the eyes of the male are distinctly separated; the frons in both sexes is black with metallic blue reflections, but the vertex behind the ocellar triangle becomes abruptly yellow. In the species which I have examined (*P. elongatus* (Fabricius) and the four new species described in this paper) vein  $R_{2+3}$  arises at or slightly before r-m and runs close to  $R_1$  to its apex, the two longitudinal veins either paralleling or gradually approaching each other. Except in *P. aculeatus*, n.sp., the male genitalia are of a quite uniform type, though differing significantly in detail: the ninth tergite is of moderate size and distinctly emarginate apically; the surstylus, which possesses characters which seem to be specifically diagnostic in this group, is separated from the tergite by a suture, ends in a blunt or sharp apex that extends far beyond the apex of the tergite, and is subtended dorsally by a translucent flange; the ninth sternite is arcuate apically; the dististyli tend to turn upward and inward toward the apex of the aedeagus; the aedeagus is thick, its skeletal apparatus black, heavily sclerotized, and either entire or bilobed apically.

The following key will separate the known Ethiopian species of *Ptecticus*. Of these, *P. rufipes*, *P. mesoxanthus*, and *P. polyxanthus* have had to be placed from the descriptions. The characters based on tarsal coloration may seem trivial, but in the species I have studied they are correlated with very definite genitalic differences.

1. Hind tarsus yellow, at most the basitarsus brownish..... 2  
Hind tarsus wholly black or black and white. 3
2. Hind legs wholly yellow.... *polyxanthus* Speiser  
Hind legs with tibiae blackened basally.  
*mesoxanthus* Grünberg  
*rufipes* Lindner
3. Hind tarsus wholly black..... 4  
Hind tarsus white at least on a large part of the second and third tarsomeres..... 5
4. Hind legs practically wholly black; abdominal terga two to six inclusively conspicuously marked with black; surstylus acute apically, its flange of equal width throughout much of its length..... *somereni*, n.sp.  
Hind legs with coxae, trochanters, femora, and parts of tibiae yellow; abdomen without black

- markings; surstylus blunt apically, its flange not of uniform width.....*rhodesiae*, n.sp.
5. Surstylus not separated from ninth tergite by a suture; aedeagus very slender, terminating in a long process which suggests a hymenopterous sting.....*aculeatus*, n.sp.  
Surstylus separated from ninth tergite by a suture; aedeagus thick, blunt, either entire or bilobed..... 6
6. Hind tarsus white beyond basitarsus; male with tergum distinctly incised apically; aedeagus bilobed; surstylus acute apically.  
*elongatus* (Fabricius)  
Hind tarsus with second tarsomere except its base and third tarsomere white; male ninth tergum transverse, not incised; aedeagus entire, not bilobed; surstylus blunt apically.

*bequaerti*, n.sp.

***Ptecticus somereni*, n. sp.**

Readily distinguished from previously described Ethiopian *Ptecticus* by the practically wholly black hind legs and the extensive black markings, over a yellow background, on the mesonotum and the abdominal terga. Related to *P. elongatus*, but the genitalia are significantly different.

*Male*.—Occiput black except median plate which, together with vertex posterior to ocellar triangle, is pale yellow; ocellar triangle and frons to callus black with bluish reflections;

frontal callus and face pale yellow, almost white. Occipital orbits with conspicuous yellow tomentum and pile, occiput otherwise with inconspicuous, short, black hair; frons and vertex black-haired; face with a little pile, black and yellow intermixed, below antennal bases. First and second antennal segments yellow, with black hair; flagellum orange-yellow; arista black. Proboscis pale yellow.

Thorax mainly yellow. Mesonotum with a median black stripe from the anterior margin to suture and a lateral one on each side, broadly separated from the humerus anteriorly and from the scutellum posteriorly, and narrowly interrupted at the suture; sternum largely blackish. Metanotum black. Pile of mesonotum largely and of scutellum wholly short, black, inconspicuous, somewhat longer and yellow laterally and anteriorly on the mesonotum; pleural pile yellow. Front leg yellow except that the coxae and the last four tarsomeres are extensively blackish; yellow pilose except dorsally on apical four tarsomeres. Middle leg with coxa, trochanter, femur except apex, and last four tarsomeres blackish and black-haired, otherwise yellow and yellow-haired. Hind leg practically entirely black and black-haired; tarsus and extreme apex of tibia ventrally yellowish brown,

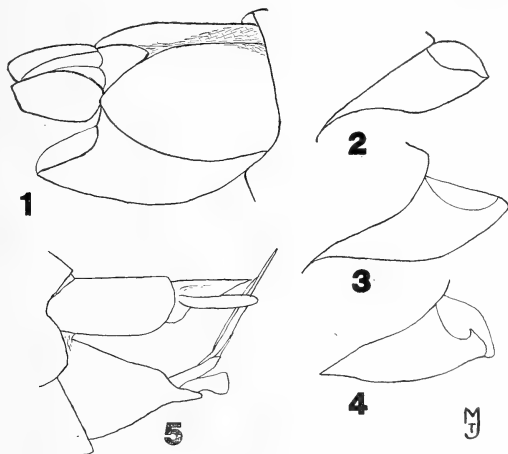

FIGS. 1-5.—1, *Ptecticus somereni*, n. sp.: Male hypopygium, dorsolateral view, from holotype. 2, *Ptecticus elongatus* (Fabricius): Surstylus of male genitalia. 3, *Ptecticus rhodesiae*, n. sp.: Surstylus of male genitalia. 4, *Ptecticus bequaerti*, n. sp.: Surstylus of male genitalia. 5, *Ptecticus aculeatus*, n. sp.: Male genitalia, lateral view, from holotype.

with some brown hairs. Wing lightly infuscated, noticeably more strongly so beyond discal cell. Variation essentially as in *elongatus*. Halteres yellow, the knobs slightly infuscated.

Abdomen mainly yellow; first tergum with two small median dark spots; second with a blackish cross band, subinterrupted medially, across the middle of the segment; third to sixth inclusively mainly black, with broad posterior yellow margins; third to fifth sterna broadly discolored medially. Yellow pile on sterna, laterally on terga, and on genital surstyli; that of terga and genitalia otherwise black. Genitalia (Fig. 1) similar to those of *elongatus*; ninth tergum more deeply incised medially; cerci more robust, oval; surstylus acute apically, as in *elongatus* but its translucent dorsal flange almost parallel-sided; dististylus more elongated, almost parallel-sided to apex, which is rounded.

Length, 15 mm.

*Type*.—Holotype male, Bwamba, Uganda, June 1948 (Van Someren); to be deposited in the British Museum (Natural History).

#### *Ptecticus rhodesiae*, n. sp.

In addition to the wholly black hind tarsus and the extensively black hind tibia, the yellow pile of the vertex and of the abdominal terga will serve to differentiate this species from at least most material of *P. elongatus* and the male genitalia show significant differences.

*Male*.—Head structurally as in *elongatus*; occiput black except median plate which, together with vertex behind the ocellar triangle, is yellow; ocellar triangle and frons to frontal callus black; frontal callus white, the face scarcely lighter in coloration. Pile of frons and face concolorous with background; that of occiput pale yellow and appressed along the orbits, otherwise black. First antennal segment whitish; second and flagellum yellow; arista mostly black. Proboscis whitish.

Thorax yellow to greenish yellow; mesonotum with evidences of a divided median and two lateral stripes. Pile of mesonotum and scutellum inconspicuous, appressed; black on the disc, yellowish on the broad sides and anterior margins of the mesonotum. Pleura and metanotum with pale, semierect pile. Wings slightly and uniformly infuscated; veins brown; venation essentially as in *elongatus*. Halteres yellow. Legs mainly yellow and yellow haired; on anterior and middle tarsi, last three tarsomeres black and last four black-haired; hind legs with tibia

except apex and tarsus wholly black and black-haired.

Abdomen yellow, more reddish toward apex, immaculate or with the terga spotted; pile bright yellow. Genitalia similar to those of *elongatus*; the aedeagus, however, is not bilobed, and the surstyli (Fig. 3), when viewed posteriorly, are blunt apically, and when viewed laterally, are more slender and more strongly bowed dorsally than in *elongatus*; as in *elongatus* the surstyli are subtended dorsally by a translucent flange, but this is straight or slightly concave dorsally in *rhodesiae* and strongly convex in *elongatus*. Ninth tergum distinctly incised apically, reddish yellow; aedeagus blackish; genitalia otherwise pale yellow.

Length, 15–16 mm.

*Female*.—Essentially as in the male, except for the broader frons and the sexual characters. The frons is brownish and the hair apparently pale, but this is probably due to the slightly general condition of the allotype. Some dark coloration on the thorax is also probably due to the condition of the specimen.

*Types*.—Holotype male, Vumba Mountains, Southern Rhodesia, Jan. 18, 1937 (Major Drysdale). Allotype female, Chirinda Forest, Southern Rhodesia, October 1926 (G. Arnold). Paratypes, 2 males, Vumba Mountains, Umtali Dist., Southern Rhodesia, March 1938 (A. Cuthbertson); 1 male, 1 female, Salisbury, Southern Rhodesia, February 1929 and January 30, 1935 (Cuthbertson). Holotype, allotype, and one paratype to be deposited in British Museum (Natural History).

#### *Ptecticus aculeatus*, n. sp.

A species with the general appearance of *P. elongatus* though somewhat more slender, the most outstanding color differences being the wholly black hind tibia and the much broader whitish apex of the hind basitarsus. The genitalia, however, are strikingly different.

*Male*.—Head structurally and in color essentially as in *elongatus*, the frons at its narrowest perhaps very slightly wider than in that species; pile of front and vertex black. Thorax yellow, mesonotum and scutellum with short black hairs, pleura yellow-pilose. Legs mainly yellow; fore tarsus somewhat darkened beyond basitarsus, middle tarsus also somewhat darkened on the last two tarsomeres; hind tibia black, hind basitarsus black and black-haired to apical fourth, thence whitish and whitish-haired.

Abdomen yellow, a brownish discal spot on the fifth tergum; black-haired on terga except laterally, yellow-haired on sterna and sides of terga. Genitalia (Fig. 5) slender; ninth tergum, from dorsal view, longer than wide and transverse apically; surstyli apparently completely submerged into the ninth tergite, not evident even as a protruding lobe; basistyle deep, dish-like, the dististylus inserted at its apex, contiguous, short, broadening and blunt apically. Proctiger slender; cerci very elongated and slender, digitate; proctiger and cerci with black pile, remaining pile of terminalia yellowish. Aedeagus heavily sclerotized, black, shining, greatly elongated and drawn out to a sharp point, somewhat suggesting the sting of a hymenopteron; the terminal part enclosed in a yellowish lightly sclerotized sheath. Length, 10 mm.

*Type*.—Holotype male, Olokemeji, Nigeria, May 7, 1936 (Van Zwaluwenburg and McGough); U. S. N. M. no. 61459.

***Ptecticus bequaerti*, n. sp.**

*Ptecticus elongatus* Fabricius, subsp., Lindner, British Mus. (Nat. Hist.) Ruwenzori Exped. 2(1-2): 2. 1939. Probably refers to the present species.

Quite similar in appearance to *P. elongatus* (Fabricius) but differing in the color of the legs and in the male genitalia. The hind tibia is yellow or yellowish on most of its apical half; the hind tarsus is black and mostly black-haired on the first, fourth, fifth, and the base of the second tarsomeres (yellow-haired ventrally on the basitarsus); the second tarsomere except its base and the third tarsomere are white and white-haired. Coloration of legs and body otherwise as in *elongatus*; there is a roundish black spot medially on tergum 5. The ninth tergum of the male is concave but hardly incised apically; the surstylus (Fig. 4) is blunt apically, its flange being truncated apically; the aedeagus is not bilobed.

*Types*.—Holotype male, Elizabethville, Belgian Congo (M. Bequaert). Allotype, female, same data. Paratypes: 1 male, Embu, British East Africa, "10-3-14, no. 123, II, G. S.J. OB"; 1 male, Vumba Mountains, Southern Rhodesia, March 1935 (A. Cuthbertson); 1 female, Mazoe, Southern Rhodesia, Jan. 28, 1929 (W. J. Hall). Holotype and allotype, James Collection; paratypes in the United States National Museum and the American Museum of Natural History.

A female, Elizabethville, which probably belongs to this species but which is not given type designation, has the hind tarsus wholly black.

**Genus *Paraptecticus* Grünberg, 1915**

The genotype, *P. viduatus* Grünberg, is the only species I know that can be referred to this genus. It is in appearance quite *Ptecticus*-like, but is structurally quite different. Another species, *P. luctuosus* Lindner, was described in this genus, but it does not belong there. I believe I have correctly identified as this species, from Lindner's description and from notes on the type furnished me by Dr. A. Collart, a female from Bwamba (H:) Uganda, June 1948 (Van Someren), Commonwealth Institute of Entomology. *P. luctuosus* will run to *Sargus* in my generic key, except that the abdomen apically becomes somewhat more noticeably broader than the thorax. This species probably should be referred to a new genus, but I refrain from proposing such until males are available.

***Pedicellina*, n. subg.**

*Pedicella* Bigot, Brauer, Denkschr. Kais. Akad. Wiss. Wien 44: 88. 1882,  *nec* Bigot, Ann. Soc. Ent. France (3) 4: 63, 83. 1856.

*Macrosargus* Bigot of Authors;  *nec* Bigot, Ann. Soc. Ent. France (5) 9: 187, 225. 1879.

Eyes of male contiguous or nearly so to frontal callus, which in turn forms the frontal triangle; lower ocular orbits, adjacent to the poorly developed or evanescent oral margin, well developed and prominent. Abdomen of male strongly constricted on second and sometimes also on third segment, broader both basad and apicad of that area; of female somewhat narrowed, sometimes definitely so, on the second segment.

Subgenotype, *Sargus notatus* Wiedemann.

Since there are intergrading forms between this and typical *Sargus*, it seems better to consider it a subgenus rather than a genus; though among American forms, where it is best represented, it represents a well defined segregate.

The unavailability of the name *Pedicella* for this group of species has been discussed previously by Aldrich (1933, p. 165) and James (1935, p. 268). Brauer's designation of *Macrosargus tenuiventris* Bigot as the genotype of *Macrosargus*, and consequently of *Pedicella*, which *Macrosargus* was proposed to replace, was invalid, since this species was not included

originally in either of the above genera and consequently the first valid generotype designation was that of *Sargus tenebrifer* Walker by Aldrich. This makes *Pedicella* either a synonym, a subgenus, or a genus closely related to *Ptecticus*, and leaves the present group without a previously available name.

**Sargus (Pedicellina) tenuis** (Lindner), n. comb.  
*Chrysochroma tenue* Lindner, Bull. Mus. Roy. Hist. Nat. Belgique 14(54): 18. 1938.

The following seems to be the male of Lindner's species, which was described from a female.

*Male*.—Eyes subcontiguous, separated by a linear black impression which is one-fourth the diameter of an ocellus; ocellar triangle almost equilateral. Occiput and vertical triangle black, the postocular orbits pale-yellow-pilose and somewhat white-dusted, the vertical triangle and frontal line black-pilose; frontal triangle ivory, becoming more yellowish on the face and brown toward the oral margin, with black and yellow pile intermixed; ocellar orbits along oral margin well developed, as broad as the width of the first antennal segment, polished black. Antenna black and black-pilose, the flagellum tending to brownish. Proboscis yellow.

Mesonotum and scutellum metallic blue-green with mostly greenish reflections, mostly black-pilose, with some erect yellowish pile laterally. Pleura mostly black, subshining with some bluish reflections; humeri white; notopleural line yellow; metapleura white; pile of pleura white to yellow. Wings lightly infumated, paler at base; veins black, brownish toward base. Halteres yellow; knobs somewhat darker. Legs yellow with the following areas black or black-

ish: all coxae except apices, apical third of front and half of middle femora; hind femur except extreme base; apical half of hind tibia; and hind tarsus from apex of basitarsus.

Abdomen with second segment very narrow, almost cylindrical, more constricted than the first; beyond the second segment gradually broadening to the fifth. Second segment mainly yellow, black on the sides of the terga and subapically; extreme apex of first tergum and base of third, most of first sternum and sometimes of third, yellow; abdomen otherwise black with bluish and bronze reflections, variable as to the light incidence. Genitalia small, black.

Length, 9 mm.

UGANDA: Two males, Bwamba Valley, July 1946 (Van Someren); male, Bwamba, July to August 1946 (Van Someren).

#### REFERENCES

- ALDRICH, J. M. *Notes on Diptera. No. 6.* Proc. Ent. Soc. Washington 35: 165-170. 1933.  
BRUNETTI, E. *New Belgian Congo Stratiomyidae, with a species from British East Africa.* Rev. Zool. Afr. 14: 123-136. 1926.  
GRÜNBERG, K. *Zoologische Ergebnisse der Expedition des Herrn F. Tessimann nach Südkamerun und Spanisch-Guinea.* Diptera. Mitt. Zool. Mus. Berlin 8: 43-70. 1915.  
JAMES, MAURICE T. *A review of the Nearctic Geosarginae (Diptera, Stratiomyidae).* Can. Ent. 67: 267-275. 1935.  
LINDNER, ERWIN. *Äthiopische Stratiomyiden (Dipt.).* Deutsche Ent. Zeitschr. 1934: 291-316. 1935.  
———. *Äthiopische Stratiomyiden (Dipt.) II.* Mitt. Deut. Ent. Ges. 8: 66-73. 1938a.  
———. *Stratiomyiden aus dem Kongo-Gebiet (Diptera).* Bul. Mus. Roy. Hist. Nat. Belgique 14(54): 1-35. 1938b.

ENTOMOLOGY.—*New names in the Homoptera.* Z. P. METCALF, North Carolina State College. (Communicated by Herbert Friedmann.)

The new names proposed herein seem to be necessary for the reasons stated. It was planned originally to publish these names in connection with the *Catalogue of the Hemiptera*, but the publication of future volumes of this catalogue may be considerably delayed. All genera are listed under the appropriate family, subfamily, and tribe, according to the classification which I now use in the card catalogue of the Homoptera of the World. This should enable any student to locate these genera. Bibliographic refer-

ences are given complete enough, I believe, to enable anyone to locate original sources. The references to names in the Homoptera have all been verified; for genera not in the Homoptera I have depended upon Neave's *Nomenclator zoologicus* 1-5. 1939-1945.

#### Family NOGODINIDAE

- Goniopsara**, n. n.  
Pro *Goniopsis* Melichar, Verh. zool.-bot. Ges. Wien 49: 292 (4). 1899.  
Nec *Goniopsis* de Haan, Fauna Japon. (Crust.): 33. 1835.  
Orthotype: *Goniopsis mystica* Melichar.

**Siopaphora**, n. n.

Pro *Siopa* Jacobi, in Voeltzkow, Reise in Ostafrika  
3: 535. 1917.

Nec *Siopa* Hendel, Wien. Ent. Zeit. 28: 253. 1909.  
Orthotype: *Siopa fumivenosa* Jacobi.

## Family FLATIDAE

## Subfamily FLATINAE

## Tribe Flatini

**Flatidissa**, n. n.

Pro *Flatida* Haglund, Öfv. Svenska Vet.-Akad.  
Förh. 56: 70. 1899.

Nec *Flatida* White, Ann. Mag. Nat. Hist. 18: 26.  
1846.

Orthotype: *Flatida furcigera* Haglund.

## Tribe Cerynini

**Adelidoria**, n. n.

Pro *Hansenia* Kirkaldy, Journ. Bombay Nat.  
Hist. Soc. 14: 53. 1902.

Nec *Hansenia* Melichar, Ann. Nat. Hofmus. Wien  
16: 228. 1901.

Orthotype: *Poekilloptera glauca* Kirby.

**Doriana**, n. n.

Pro *Doria* Melichar, Ann. Nat. Hofmus. Wien 16:  
231. 1901.

Nec *Doria* Meigen, Syst. Besch. Zweifl. Insekt.  
7: 263. 1838.

Orthotype: *Poekilloptera conspersa* Walker.

## Tribe Flatissini

**Phylliana**, n. n.

Pro *Mesophylla* Melichar, Ann. Nat. Hofmus.  
Wien 17: 53. 1902.

Nec *Mesophylla* Thomas, Ann. Mag. Nat. Hist.  
(7) 8: 143. 1901.

Orthotype: *Mesophylla inclinata* Melichar.

## Tribe Selizini

**Melichitona**, n. n.

Pro *Chitona* Melichar, Genera insectorum 182: 114.  
1923.

Nec *Chitona* Schmidt, Linnaea Ent. 1: 134. 1846.  
Orthotype: *Phalaenomorpha collaris* Jacobi.

## Family ISSIDAE

## Subfamily CALISCELINAE

## Tribe Caliscelini

**Itatiayana**, n. n.

Pro *Itatiaya* Schmidt, Stettin. Ent. Zeit. 93: 43.  
1932.

Nec *Itatiaya* Mello-Leitão, Brotéria 13: 139. 1915.  
Orthotype: *Itatiaya banzhafi* Schmidt.

**Ugandana**, n. n.

Pro *Ugandella* Schmidt, Stett. Ent. Zeit. 93: 43.  
1932.

Nec *Ugandella* Sjoestedt, Ark. Zool. 15 (6): 18.  
1923.

Orthotype: *Afronaso bayoni* Schmidt.

## Tribe Ommatidiotini

**Bergrothora**, n. n.

Pro *Schmidtella* Bergroth, Wien. Ent. Zeit. 29:  
241. 1910.

Nec *Schmidtella* Ulrich, Amer. Geol. 10: 269. 1892.  
Orthotype: *Bruchomorpha globosa* Melichar.

## Subfamily HEMISPHERIINAE

**Hemiphile**, n. n.

Pro *Herophile* Stål, Hemiptera Africana 4: 203.  
1866.

Nec *Herophile* Stenstrup, Overs. Danske Selsk.  
1860: 121. 1860.

Orthotype: *Hemisphaerius latipes* Stål.

**Darumara**, n. n.

Pro *Daruma* Matsumura, Trans. Sapporo Nat.  
Hist. Soc. 6: 103. 1916.

Nec *Daruma* Jordan and Starks, Proc. U. S. Nat.  
Mus. 27: 232, 241. 1904.

Orthotype: *Daruma nitobei* Matsumura.

## Subfamily ISSINAE

## Tribe Hysteropterini

**Perissana**, n. n.

Pro *Perissus* Melichar, Abh. zool.-bot. Ges. Wien  
3 (4): 113. 1906.

Nec *Perissus* Chevrolat, Mém. Soc. Sci. Liège 18:  
262. 1863.

Orthotype: *Issus jakowleffi* Puton.

## Tribe Issini

**Distiana**, n. n.

Pro *Moniana* Distant, Ann. Mag. Nat. Hist. (8)  
4: 76. 1909.

Nec *Moniana* Girard, Proc. Acad. Nat. Sci. Phila-  
delphia 8: 199. 1856.

Orthotype: *Moniana andrewsi* Kirby.

**Issella**, n. n.

Pro *Issina* Melichar, Abh. zool.-bot. Ges. Wien  
3 (4): 209. 1906.

Nec *Issina* Jousseaume, Le Naturaliste (2) 12:  
22. 1898.

Orthotype: *Issina suturalis* Melichar.

## Family RICANIIDAE

## Subfamily RICANIINAE

## Tribe Ricaniini

**Meliprivesa**, n. n.

Pro *Neoprivesa* Melichar, Genera insectorum 182:  
145. 1923.

Nec *Neoprivesa* Distant, Trans. Linn. Soc. Lon-  
don (2) 17: 297. 1917.

Orthotype: *Neoprivesa disturbata* Melichar.

## Family LOPHOPIDAE

## Subfamily ACARNINAE

## Tribe Acarnini

**Meloenopia**, n. n.

Pro *Oenopia* Melichar, Časopis České Spol. Ent.  
10: 158 (8). 1913.

Nec *Oenopia* Mulsant, Ann. Soc. Agr. Lyon (2) 2: 420. 1850.

Orthotype: *Oenopia princeps* Melichar.

Family EURYBRACHIDAE

Subfamily EURYBRACHINAE

Tribe Loxocephalini

*Nesiana*, n. n.

Pro *Nesis* Stål, Öfv. Svenska Vet.-Akad. Förh. 18: 210. 1861.

Nec *Nesis* Mulsant, Ann. Soc. Agr. Lyon (2) 2: 67. 1850.

Orthotype: *Eurybrachys tricolor* Walker.

Subfamily PLATYBRACHINAE

Tribe Platybrachini

*Maeniana*, n. n.

Pro *Maenia* Jacobi, Ark. Zool. 19A (28): 6. 1928.

Nec *Maenia* Dalton, Geol. Rec. 1877: 392. 1880.

Orthotype: *Maenia hirsuta* Jacobi.

Family MACHAEROTIDAE

Subfamily HINDOLINAE

Tribe Hindolini

*Soamachaerota*, n. n.

Pro *Soa* Jacobi, Ark. Zool. 19A (28): 46. 1928.

Nec *Soa* Enderlein, Zool. Jahrb. (Abt. Syst.) 20: 109. 1904.

Orthotype: *Polychaetopyhes appendiculata* Hacker.

Family TOMASPIDAE

Subfamily TOMASPINAE

Tribe Cosmocarini

*Horvathiana*, n. n.

Pro *Horvathiella* Lallemand, Ann. Mus. Nat. Hungarici 32: 60. 1939.

Nec *Horvathiella* Poppius, Acta Soc. Sci. Fennica 41: 115. 1912.

Orthotype: *Horvathiella rubrovittata* Lallemand.

Family CERCOPIIDAE

Subfamily CERCOPINAE

Tribe Petylini

*Pentacanthoides*, n. n.

Pro *Pentacantha* Lallemand, Bull. Mus. Hist. Nat. Paris 28: 64. 1922.

Nec *Pentacantha* Stål, Öfv. Svenska Vet.-Akad. Förh. 28: 400. 1871.

Orthotype: *Pentacantha brunnea* Lallemand.

Tribe Lepyrioniini

*Balsana*, n. n.

Pro *Balsa* Stål, Hemiptera Africana 4: 66. 1866.

Nec *Balsa* Walker, Can. Nat. 5: 250. 1860.

Orthotype: *Lepyronia obscurata* Amyot and Serville.

*Paralepyroniella*, n. n.

Pro *Eulepyroniella* Lallemand, Bull. Inst. Franç. Afrique Noire 12: 630. 1950.

Nec *Eulepyroniella* Schmidt, Ent. Mitt. 14: 112. 1925.

Orthotype: *Lepyronia aethiops* Distant.

Family TETTIGELLIDAE

Subfamily TETTIGELLINAE

Tribe Tettigellini

*Ceratogoniella*, n. n.

Pro *Ceratogonia* Melichar, Ann. Mus. Nat. Hungarici 23: 350. 1926.

Nec *Ceratogonia* Kolbe, Ent. Nachr. 25: 45. 1899.

Orthotype: *Tettigonia recta* Fowler.

*Poecilocardia*, n. n.

Pro *Poeciloscarta* Melichar, Ann. Mus. Nat. Hungarici 23: 342. 1926.

Nec *Poeciloscarta* Stål, Handl. Svenska Vet.-Akad. 8 (1): 73. 1869.

Orthotype: *Tettigonia binaria* Signoret.

Tribe Ciccini

*Cicciana*, n. n.

Pro *Ciccus* Stål, Handl. Svenska Vet.-Akad. 8 (1): 60. 1869.

Nec *Ciccus* Latreille, Cuvier's Règne animal (nouvelle ed.) 5: 221. 1829.

Orthotype: *Ciccus latreillei* Distant.

The genus *Ciccus* was described by Latreille without any included species; however, in 1831, in the Animal Kingdom by Cuvier, translated by McMurtrie, 4: 46, two species, *Cicada adspersa* Fabricius and *marmorata* Fabricius, were included, and in 1903 Kirkaldy, Entomologist, 36: 232, selected *Ciccus adspersus* Fabricius as the genotype. Later, Distant noted that the *Tettigonia adspersa* Burmeister [nec Fabricius], Handbuch der Entomologie 2 (1): 119, was not the same as *Cicada adspersa* Fabricius. He established a new name, *Ciccus latreillei*, for this species, which he named as the type of *Ciccus*. In this he was followed by later authors (Melichar, Ann. Mus. Nat. Hungarici 21: 206, 1924; Schmidt, Stett. Ent. Zeit. 89: 37, 1928; and Evans, Trans. Ent. Soc. London 98: 168, 1947). In the meantime, Stål, Handl. Svenska Vet.-Akad. 8 (1): 65, 1869, established the genus *Coelopola* and assigned *Cicada adspersa* Fabricius to it. *Ciccus* Latreille with genotype *Cicada adspersa* Fabricius will stand, and the *Ciccus* Stål must be renamed with *Ciccus latreillei* Distant as the genotype. *Ciccus* Latreille equals *Coelopola* Stål.

Family LEDRIDAE

Subfamily LEDRINAE

Tribe Xerophloeini

*Epiclinata*, n. n.

Pro *Epiclines* Amyot and Serville, Histoire naturelle des insectes: Hémiptères: 577. 1843.

Nec *Epiclines* Chevrolat, Mag. Zool. 8: 40. 1838.

Orthotype: *Membracis planata* Fabricius.



## Family EUSCELIDAE

## Subfamily EUSCELINAE

## Tribe Euscelini

**Oxytettigella**, n. n.

Pro *Oxytettix* Ribaut, Bull. Soc. Hist. Nat. Toulouse **77**: 263. 1942.

Nec *Oxytettix* Rehn, Proc. Acad. Nat. Sci. Philadelphia **81**: 482. 1929.

Orthotype: *Jassus viridinervis* Kirschbaum.

## Tribe Thamnotettixini

**Matsumuratettix**, n. n.

Pro *Epitettix* Matsumura, Journ. Coll. Agr. Sapporo **5**: 194. 1914.

Nec *Epitettix* Hancock, Trans. Ent. Soc. London **1907**: 216. 1907.

Orthotype: *Epitettix hiroglyphica* Matsumura.

## Subfamily DELTOCEPHALINAE

## Tribe Scaphytopini

**Osbornitettix**, n. n.

Pro *Calotettix* Osborn, Bull. Bernice P. Bishop Mus. **114**: 247. 1934.

Nec *Calotettix* Bruner, Biologia Centrali-Americana, Zool. Orth., **2**: 309. 1908.

Orthotype: *Calotettix metrosideri* Osborn.

**Rhombopsana**, n. n.

Pro *Rhombopsis* Haupt, Bull. Palestine Agr. Exp. Stat. **8**: 22. 1927.

Nec *Rhombopsis* Gardner, Maryland Geol. Surv. Upper Cret.: 456. 1916.

Orthotype: *Rhombopsis virens* Haupt.

According to Neave, Nomenclator Zoologicus **4**: 56, Gardner's name is an unnecessary new name for *Neptunella* Meek, but this would not change the status of Haupt's name.

## Tribe Balcluthini

**Lindbergana**, n. n.

Pro *Nesotettix* Lindberg, Comm. Biol. **6** (9): 6. 1936.

Nec *Nesotettix* Holdhaus, Denkschr. Akad. Wiss. Wien **84**: 555. 1909.

Orthotype: *Nesotettix freyi* Lindberg.

## Tribe Macrostelini

**Marquesitettix**, n. n.

Pro *Marquesia* Osborn, Bull. Bishop Mus. **114**: 250. 1935.

Nec *Marquesia* Malloch, Bull. Bishop Mus. **98**: 222. 1932.

Orthotype: *Marquesia atra* Osborn.

## Family COELIDIIDAE

## Subfamily COELIDIINAE

## Tribe Coelidiini

**Aletta**, n. n.

Pro *Palicus* Stål, Hemiptera Africana **4**: 120. 1866.

Nec *Palicus* Philippi, Jahresb. Ver. Nat. Cassel **2**: 11. 1838.

Orthotype: *Coelidia lineoligera* Stål.

**Nisitrana**, n. n.

Pro *Nisitra* Walker, Journ. Linn. Soc. London, Zool., **10**: 327. 1870.

Nec *Nisitra* Walker, Cat. Dermapt. Saltat. British Mus. **1**: 91. 1869.

Orthotype: *Nisitra telifera* Walker.

## Family IASSIDAE

## Subfamily IASSINAE

## Tribe Selenocephalini

**Discocephalana**, n. n.

Pro *Discocephalus* Kirschbaum, Jahrb. Ver. Naturk. Nassau **13**: 356. 1858.

Nec *Discocephalus* Ehrenberg, Sym. Phys. Phyt. Sign. e. 1831.

Orthotype: *Discocephalus viridis* Kirschbaum.

**Doradana**, n. n.

Pro *Dorada* Melichar, Berliner Ent. Zeit. **47**: 276. 1903.

Nec *Dorada* Jaroeki, Zoologia **4**: 200. 1822.

Orthotype: *Dorada lativentris* Kuhlitz and Melichar.

## Family IDIOCERIDAE

**Zaletta**, n. n.

Pro *Macrocerus* Evans, Trans. Roy. Soc. South Australia **65**: 39. 1941.

Nec *Macrocerus* Motschulsky, Bull. Soc. Imp. Nat. Moscow **18** (1): 38. 1845.

Orthotype: *Macrocerus minutus* Evans.

## Family CICADIDAE

## Subfamily TIBICENINAE

## Tribe Tibicenini

**Orialella**, n. n.

Pro *Oria* Distant, Ann. Mag. Nat. Hist. (7) **14**: 429. 1904.

Nec *Oria* Huebner, Verz. Bekannt. Schmett. (15) **1821**: 240. 1821.

Orthotype: *Oria boliviana* Distant.

## Tribe Fidicinini

**Dorisiana**, n. n.

Pro *Dorisia* Delétang, Anal. Soc. Cient. Argentina **88**: 63, 65. 1919.

Nec *Dorisia* Moeschler, Verh. zool.-bot. Ges. Wien **32**: 351. 1883.

Orthotype: *Cicada semilata* Walker [= *Cicada viridis* Olivier (nec *Cicada viridis* Linné, id est *Tettigella viridis* Linné)].

## Family TIBICINIDAE

## Subfamily TIBICININAE

## Tribe Dazini

**Procollina**, n. n.

Pro *Collina* Distant, Biologia Centrali-Americana **1**: 142. 1905.

Nec *Collina* Bonarelli, Boll. Soc. Geol. Ital. **12** (2): 205, 207. 1893.

Orthotype: *Collina biolleyi* Distant.

Tribe Carinetini

**Paranistria**, n. n.

Pro *Tympanistria* Stål, Ann. Soc. Ent. France (4) **1**: 619. 1862.

Nec *Tympanistria* Reichenbach, Av. Syst. Nat. Text. 1852-53: xxv.

Orthotype: *Tympanistria villosa* Fabricius.

Family MEMBRACIDAE

Subfamily DARNINAE

Tribe Hebesini

**Hypheodana**, n. n.

Pro *Hypheus* Stål, Öfv. Vet.-Akad. Förh. **24**: 557. 1867.

Nec *Hypheus* Gistel, Syst. Ins. **1** (1): 131. 1838.

Orthotype: *Thelia ursus* Fairmaire.

Subfamily CENTROTINAE

Tribe Hebesini

**Acanthicoides**, n. n.

Pro *Acanthicus* Laporte, Ann. Soc. Ent. France **1**: 227. 1832.

Nec *Acanthicus* Spix, Pisc. Brazil. **1829**: 2. 1829.

Orthotype: *Acanthicus stollii* Laporte.

Funkhouser, Genera insectorum **208**: 171, states that this genus can not stand because it is based on an immature form. This, however, is contrary to the International Rules of Zoological Nomenclature, Article 27b.

Tribe Uroxiphini

**Mesocentrina**, n. n.

Pro *Mesocentrus* Funkhouser, Philippine Journ. Sci. **18**: 681. 1921.

Nec *Mesocentrus* Szepliget, Termés. Füzetek **23**: 56. 1900.

Orthotype: *Mesocentrus pyramidatus* Funkhouser.

Subfamily SMILINAE

Tribe Ceresini

**Melusinella**, n. n.

Pro *Melusina* Stål, Öfv. Svenska Vet.-Akad. Förh. **24**: 552. 1867.

Nec *Melusina* Meigen, N. Class. Mouches: 19. 1800.

Orthotype: *Ceresa nervosa* Fairmaire.

Tribe Telamonini

**Maturnaria**, n. n.

Pro *Maturna* Stål, Öfv. Svenska Vet.-Akad. Förh. **24**: 555. 1867.

Nec *Maturna* Koch, Uebers. Arachnidensyst. **5**: 65. 1850.

Orthotype: *Ozygonia ephippigera* Fairmaire.

Superfamily \*FULGOROIDEA

\* **Mecynostomata**, n. n.

Pro \* *Mecynostoma* Brongniart, Rech. Hist. Ins. Foss. Temps Prim. 451. 1893.

Nec *Mecynostoma* Graff, Monogr. Turbell. **1**: 237. 1882.

Orthotype: \* *Mecynostoma dorhni* Brongniart.

Family \*FULGORIDAE

\* **Nyktalos**, n. n.

Pro \* *Nyctophylax* Scudder, Foss. Ins. **2**: 279. 1890.

Nec *Nyctophylax* Fitzinger, Sitzb. Akad. Wiss. Wien, Math.-nat. Cl., **42**: 390. 1860.

Orthotype: \* *Nyctophylax uhleri* Scudder.

NAMES TO BE RESTORED

**Cyrtoisa** Fitch, Ann. Rep. State Cab. Nat. Hist. **4**: 49. 1851.

Logotype: *Cyrtoisa fenestrata* Fitch.

This name was spelled this way by Fitch originally. We have no way of knowing that this is a misspelling, even though Fitch gives the derivation as from the Greek *κυπρός*, curved or hump-backed. He may have been familiar with Perris's *Cyrtosia*, Ann. Soc. Ent. France **8**: 54, 1839, and deliberately reversed the two letters in order to avoid a homonym. *Cyrtolobus* Goding, Trans. Amer. Ent. Soc. **19**: 257, 1892, was proposed as a new name for *Cyrtoisa* [sic] Fitch (nec *Cyrtosia* Perris). Corrections in the original spelling should be avoided as indicated below under the genus *Pseudeoscarta*. *Cyrtolobus* Goding is therefore a synonym of *Cyrtoisa* Fitch.

**Errhomenus** Fieber, Verh. zool.-bot. Ges. Wien **16**: 501. 1866.

Haplotype: *Errhomenus brachypterus* Fieber.

Puton, Catalogue des hémiptères de la faune Paléarctique, ed. 3: 79, 1886, lists *Errhomenellus* Puton and places *Errhomenus* Fieber (1866) as a synonym, and this has been followed by most subsequent authors. However, as I can find no reason for this, I restore *Errhomenus* Fieber (1866).

**Euides** Fieber, Verh. zool.-bot. Ges. Wien **16**: 519. 1866.

Logotype: *Delphax basilinea* German.

Puton, Catalogue des Hémiptères de la faune Paléarctique, ed. 3: 72, 1886, lists *Euidella* with *Euides* Fieber (1866) as a synonym. I can find no reason for this unless *Euides* was confused

\* This denotes fossil forms.

with *Eueides* Huebner, Verz. bekannt. Schmett. 1816: 11. I therefore restore *Euides* Fieber. *Eueides* Kirkaldy, Entomologist **37**: 175, 1904, will also be a synonym.

**Harmonides** Kirkaldy, Entomologist **35**: 316. 1902. Logotype: *Darnis reticulata* Fabricius (= *Parmula bistrigata* Fairmaire).

This name was proposed to replace *Parmula* Fairmaire, Ann. Soc. Ent. France (2) **4**: 490, 1847, nec *Parmula* Heyden, Isis von Oken 1825: 589. Two years later Kirkaldy, Entomologist **37**: 279, 1904, proposed *Boethoos* a new name, for *Parmula* Fairmaire. Since *Harmonides* is the earlier name and, so far as I can discover, has never been used before, it should be restored.

**Ophiola** Edwards, Ent. Monthly Mag. **58**: 206, 207. 1922. 1949. Logotype: *Cicada striatula* Fallen:

Oman, Mem. Ent. Soc. Washington **3**: 152, 1949, makes this a synonym of *Scleroracrus* Van Duzee based on Van Duzee's statement Can. Ent. **26**: 136, 1894, that there is a specimen in the U. S. National Museum labeled *Scleroracrus anthracinus* Uhler. I refuse to accept museum labels, either published or unpublished, as having any standing in nomenclature whatsoever. This, apparently, was Van Duzee's idea, as he

described a new species, *Athysanus anthracinus*, based on specimens from Iowa from Prof. Herbert Osborn and from Colorado from Prof. C. P. Gillette, Van Duzee, Can. Ent. **26**: 137, 1894, says: "Prof. Osborn's specimen came labelled *Conogonus gagates*, Ashm., and in the National Museum is an example labelled *Scleroracrus anthracinus*, Uhler. I have adopted Mr. Uhler's specific name as very appropriate for this deep black little Jassid, but I can find no characters to separate it generically from *Athysanus*."

I could argue from this that the genus should be called *Conogonus*, as this name on a museum label has line priority over *Scleroracrus* and that the species name *gagates* Ashmead would replace *anthracinus* Van Duzee.

**Pseudeoscarta** Lallemand, Journ. Federated Malay States Mus. **17**: 375. 1933. Haplotype: *Pseudeoscarta pendleburyi* Lallemand.

As listed by Neave, Nomenclator Zoologicus **3**: 1003, *Pseudeoscarta* is an unnecessary correction for *Pseudeoscarta* Lallemand (1933). Lallemand was apparently establishing a false *Eoscarta*, not a false *Scarta*; hence the elimination of the *o* at the end of *Pseudo* to avoid three vowels following one another. Later Lallemand, Mem. Inst. Royal Sci. Nat. Belgique (2) **32**: 40, 54, 1949, wrote *Pseudeoscarta*.

ZOOLOGY.—*The marine annelids of the United States Navy Antarctic Expedition, 1947-48.*<sup>1</sup> OLGA HARTMAN, Allan Hancock Foundation, University of Southern California. (Communicated by Fenner A. Chace, Jr.)

A small though interesting collection of polychaetous annelids was collected by Comdr. David C. Nutt, USNR, during the United States Navy Antarctic Expedition, 1947-48. Twenty-nine species, including one new, *Octobranchus phyllocomus*, in 15 families are represented. Most of the specimens come from Marguerite Bay; others are from Ross Island, Knox coast, and vicinity of Peter I Island. Depths range from shore to 115 fathoms. The collections with type specimen are deposited in the United States National Museum; a partial duplicate set is at the Allan Hancock Foundation. The illustrations were prepared by Anker Petersen. I am indebted to the Administration of the

Allan Hancock Foundation for permission to examine these materials.

#### FAMILY POLYNOIDAE

##### **Barrukia cristata** (Willey)

*Gattyana cristata* Willey, 1902, p. 268, pl. 44, figs. 1-4.

*Barrukia cristata* Bergström, 1916, pp. 297-299, pl. 5, figs. 7-9, 14.

*Localities*.—Marguerite Bay, 40 fathoms, water temperature 30°F., Feb. 22, 1948 (1 specimen); 85-105 fathoms, water temperature 30.2°F., Feb. 19, 1948 (1 specimen).

##### **Harmothoë spinosa** Kinberg

*Harmothoë spinosa* Kinberg, 1855, p. 386; Bergström, 1916, pp. 284-286, pl. 2, figs. 5, 6, pl. 3, figs. 1-4.

*Localities*.—Marguerite Bay, 35 fathoms,

<sup>1</sup> Contribution 87 from the Allan Hancock Foundation, University of Southern California, Los Angeles, Calif.

Feb. 20, 1948 (2 specimens), 40 fathoms, Feb. 22, 1948 (4 specimens). Peter I Island, 30 fathoms, Feb. 15, 1948 (7 specimens). Off Point #13 Island, Knox coast, 66°31' S., 110°26' E. in 110 fathoms, Jan. 19, 1948 (1 specimen). Off Cape Royds, Ross Island, 58 fathoms, Jan. 29, 1948 (about 10 specimens).

*Notes.*—Some specimens are very dark on both sides of the body, with parapodia and setae pale; others are checkered instead of dark. These variations agree with some described and shown by Ehlers (1913, pl. 26, colored).

#### **Harmothoë magellanica** (McIntosh)

*Lagisca magellanica* McIntosh, 1885, pp. 82-83, pl. 13, fig. 5, pl. 18, figs. 3, 4, pl. 7a, figs. 1, 2.

*Harmothoë magellanica* Bergström, 1916, pp. 280-282, pl. 4, figs. 1-3.

*Localities.*—Marguerite Bay, 35 fathoms, Feb. 20, 1948 (8 specimens); 40 fathoms, Feb. 22, 1948 (about 9 specimens).

#### **Polyeunoa laevis** McIntosh

*Polyeunoa laevis* McIntosh, 1885, pp. 76-77, pl. 12, fig. 2, pl. 20, fig. 8, pl. 7a, figs. 12, 13; Bergström, 1916, pp. 288-291, pl. 3, fig. 7.

*Localities.*—Marguerite Bay, 35 fathoms, Feb. 20, 1948 (1 specimen); 40 fathoms, associated with arborescent alcyonarians, Feb. 22, 1948 (2 specimens).

#### Family PHYLLODOCIDAE

##### **Anaitides patagonica** (Kinberg)

*Carobia patagonica* Kinberg, 1865, p. 242.

*Anaitides patagonica* Bergström, 1914, pp. 147-149, fig. 46.

*Locality.*—Marguerite Bay, 35 fathoms, Feb. 20, 1948 (1 specimen).

##### **Genetyllis polyphylla** (Ehlers)

*Phyllodoce polyphylla* Ehlers, 1897, pp. 26-28, pl. 1, figs. 14-19.

*Genetyllis polyphylla* Berystrom, 1914, pp. 161-163, fig. 55.

*Locality.*—Marguerite Bay, 35 fathoms, Feb. 20, 1948 (1 specimen).

#### Family SYLLIDAE

##### **Trypanosyllis gigantea** (McIntosh)

*Syllis gigantea* McIntosh, 1885, p. 193, pl. 30, figs. 1-3, pl. 33, fig. 4, pl. 10A, fig. 14, pl. 24A, fig. 7.

*Trypanosyllis gigantea* Ehlers, 1901, p. 85, pl. 6, figs. 11-16.

*Locality.*—Marguerite Bay, 35 fathoms, Feb. 20, 1948 (1 specimen).

#### **Syllis brachycola** Ehlers

*Syllis brachycola* Ehlers, 1897, p. 38, pl. 2, figs. 46-47; Monro, 1930, p. 100, figs. 33 a-b.

*Locality.*—Marguerite Bay, 40 fathoms, Feb. 22, 1948 (about 15 specimens).

*Notes.*—Some have a pigmented pattern on the dorsum of anterior 15 to 20 segments; there are dark, transverse, segmental bands alternating with similar though medially broken, intersegmental bars. Dorsal cirri are short, with 15 to 20 articles. Composite setae are distally bidentate.

#### Family NEPHTYIDAE

##### **Aglaophamus macroura** (Schmarda)

*Nephtys macroura* Schmarda, 1861, p. 91, 3 figs.

*Aglaophamus macroura* Hartman, 1950, pp. 118-120.

*Localities.*—65°25' S., 101°13' E., 100 fathoms, Jan. 14, 1948 (3 specimens). Peter I Island, 30 fathoms, Feb. 15, 1948 (1 specimen).

#### Family NEREIDAE

##### **Nereis kerguelensis** McIntosh

*Nereis kerguelensis* McIntosh, 1885, p. 225, pl. 35, figs. 10-12, pl. 16A, figs. 17-18; Ehlers, 1897, p. 65, pl. 4, figs. 81-83.

*Locality.*—Marguerite Bay, 35 fathoms, Feb. 20, 1948 (1 specimen), 40 fathoms, Feb. 22, 1948 (1 specimen).

#### Family LUMBRINERIDAE

##### **Lumbrineris magalhaensis** (Kinberg)

*Lumbriconereis magalhaensis* Kinberg, 1865, p. 568; 1910, p. 47, pl. 18, fig. 35.

*Lumbrineris magalhaensis* Hartman, 1948, p. 93, pl. 14, figs. 1-3.

*Locality.*—Off Cape Royds, Ross Island, 50 fathoms, Jan. 29, 1948 (1 specimen).

#### Family ORBINIIDAE

##### **Scoloplos (Leodamas) marginatus** (Ehlers)

*Aricia marginata* Ehlers, 1897, p. 95, pl. 6, figs. 150-156.

*Locality.*—Off Cape Royds, Ross Island, 50 and 58 fathoms, Jan. 29, 1948 (about 12 specimens).

#### Family OPHELIIDAE

##### **Travisia lithophila** Kinberg

*Travisia lithophila* Kinberg, 1866, p. 256; 1910, p. 66, pl. 25, fig. 4.

*Locality*.—65°25' S., 101°13' E., 100 fathoms, Jan 14, 1948 (1 specimen).

**Ammotrypane gymnopyge** Ehlers

*Ammotrypane gymnopyge* Ehlers, 1908, p. 118, pl. 17, figs. 1-4.

*Locality*.—Peter I Island, 30 fathoms, Feb. 15, 1948 (6 specimens).

Family FLABELLIGERIDAE

**Flabelligera mundata** Gravier

*Flabelligera mundata* Gravier, 1907, pp. 37-39, pl. 4, figs. 31-32.

*Localities*.—Marguerite Bay, 115 fathoms, Feb. 18, 1948 (1 specimen), 35 fathoms, Feb. 20, 1948 (7 specimens), 40 fathoms, Feb. 22, 1948 (2 specimens).

Family SCALIBREGMIDAE

**Oncoscolex dicranochaetus** Schmaroda

*Oncoscolex dicranochaetus* Schmaroda, 1861, p. 55, 4 figs., pl. 26, fig. 206.

*Locality*.—Marguerite Bay, 40 fathoms, Feb 22, 1948 (1 specimen).

Family AMPHARETIDAE

**Amphiteis gunneri antarctica** Hesse

*Amphiteis gunneri antarctica* Hesse, 1917, pp. 116-117, pl. 1, fig. 10.

*Localities*.—66°35' S., 90°40' E., 150 fathoms Dec. 30, 1947 (1 specimen). 65°25' S., 101°13' E., 100 fathoms, Jan. 14, 1948 (1 specimen). Off Cape Royds, Ross Island, 58 fathoms, Jan. 29, 1948 (1 specimen). Peter I Island, 30 fathoms, Feb. 15, 1948 (14 specimens).

Family TRICHOBRANCHIDAE

**Trichobranchus glacialis antarcticus** Hesse

*Trichobranchus glacialis antarcticus* Hesse, 1917, p. 132.

*Locality*.—Off Cape Royds, Ross Island, 50 fathoms, Jan. 29, 1948 (1 specimen).

*Notes*.—There are three pairs of filiform branchiae that resemble one another. The peristomial ring is plain; it lacks eyespots. The body cavity is crowded with ova.

**Octobranchus phyllocomus**, n. sp.

Figs. 1-12

*Type*.—U.S.N.M. no. 23771.

*Locality*.—Off Cape Royds, Ross Island, 50 fathoms, Jan. 29, 1948 (1 specimen).

The single specimen is posteriorly incomplete; it measures 20 mm long and 3.3 mm wide in front at the postbranchial region of the body. It consists of the head region, 16 thoracic and 6 abdominal setigerous segments. Preserved the body is pale or white, except for the dark eye spots that are strewn on the peristomial collar.

The most striking feature concerns the foliaceous character of the branchiae, especially the second pair (Fig. 5); they resemble those in the ampharetid genus *Phyllocomus* Grube; hence the specific name. The thoracic uncini are long-handled, and in other respects this individual agrees with members of the family Trichobranchidae.

The oral tentacles are very numerous and filiform except for their tips, which are longitudinally grooved and somewhat spatulate. They form a dense tuft at the anterior end of the body. They are of varying length; the longest are on the ventral, the shortest on the dorsal side. The membrane to which the tentacles are attached is U-shaped around the oral aperture; it is completely covered except for a pair of free lateral lobes at the sides of the mouth.

The lateral lobes (Fig. 1) of the thorax consist of four well-developed pairs. All are continued across the ventrum as smooth-margined, collar membranes. The first pair is the smallest; it is ventrolateral in position and largely concealed by the much larger second pair. Its base can be followed dorsally to that of the first branchial pair. The second lateral lobes are the largest and most prolonged in their lateral parts; they extend across the ventrum as the longest collar membrane; their upper bases can be traced in line with the bases of the second branchial pairs. The third lateral lobes resemble the second pair but are somewhat smaller and slightly more ventral; their bases are in line with the bases of the third branchial pairs. The fourth lateral lobes are increasingly smaller and slightly ventrolateral in position; the expanded upper part is below the first notopodial fascicle and its base in line with that of the fourth branchial pair.

The peristomial base is strewn with many dark eyespots, most numerous at the sides of the body; the eyes are not seen unless the large

lateral lobes of the second pair are pushed to one side.

Branchiae are dorsal, number four pairs, and are inserted between the bases of the lateral lobes. All are similar in that each consists of a basal foliaceous part terminating distally in a slender filament. The first pair is inserted far in front of and within the others; its proportions are shown in Fig. 4. The second pair is lateralmost; it is broadest and subquadrate in its basal part (Fig. 5). The third (Fig. 6) and fourth (Fig. 7) pairs are similar to each other, but the third is the larger and terminates in a longer filament. Striking features of all branchial pairs are the bilimbate character of the basal parts and the richly branched circulatory vessels which can be seen through the membranous epithelium.

There are 16 thoracic setigerous segments. The first notopodia are smallest and slender-conical in shape; they are provided with a bundle of slender setae directed distally. The second notopodia are larger and heavier than the first; farther back they come to be compressed, triangular processes (Fig. 2) and have transverse series of setae between their presetal and postsetal lobes. Thoracic setae consist of about seven larger, broader and eight slenderer, shorter ones in a single transverse series.

Thoracic uncini are first present from the fifth setigerous segment, at first arranged in a short, transverse series; farther back the row increases in length. The uncini (Fig. 8) are of a single kind and number 15 to 25 in a row. Each consists of a long handle that terminates distally in a fang surmounted by a rostrate series of transverse ridges (Figs. 9, 10).

Only a few abdominal segments are present on the single specimen. Abdominal parapodia are lateral in position; each is in the form of a rectangular plaque (Fig. 3) with the uncini arranged in a single series at the outer distal margin. The uncini number about 30 in a row. They are all similar, avicular, lack a handle. Seen individually (Fig. 11) each consists of a thin subcircular plate with a major fang surmounted by two transverse rows of smaller teeth, the middle one with about five teeth, the distal one with about eight smaller ones (Fig. 12).

The genus *Octobranchus* Marion and Bobretzky is a group of few species (see Hesse, 1917, p. 134); they include *O. antarcticus* Monro (1936, pp. 185-187, fig. 33) from south Georgia,

*O. japonicus* Hesse (1917, pp. 134-135, pl. 1, figs. 13-15) from Japan and *O. lingulatus* (Grube) (1863, pp. 56-57, pl. 6, fig. 1) from the Mediterranean Sea. In these the branchiae are said to be filiform (Monro, 1936, p. 185). *O. phyllocomus* departs from the other species in that the second pair of branchiae is conspicuously foliaceous.

*O. antarcticus* Monro (1936, pp. 185-186) is known from a single, imperfect individual from Schollaert Channel, Palmer Archipelago, 278-500 meters, mud bottom. The tentacles and all except a fourth pair of branchiae were lost when the original description was made. The lateral lobes resemble those of the present species but are less developed in their lateral parts. The first notopodia are on the last branchial segment and uncini begin on the fourth setigerous segment.

#### Family TERESELLIDAE

##### *Terebella ehlersi* Gravier

*Terebella ehlersi* Gravier, 1907, pp. 47-50, text figs. 30-31, plate figs. 45-46.

*Localities*.—Marguerite Bay, 35 fathoms, Feb. 20, 1948 (1 specimen); 40 fathoms, Feb. 22, 1948 (several specimens).

*Notes*.—The greatest length is about 70 mm. The peristomial ring shows no eye spots, but they are supposedly present (Hesse, 1917, p. 190). Notosetal fascicles of pointed setae are present on many (to 47) or fewer segments; the fascicles decrease in size going back and gradually disappear on 20 or more posterior segments. Ventral gland shields occur on 15 segments. There are no lateral lappets. A prominent nephridial papilla is present on each side, between the bases of the first and second branchiae. Notosetae are conspicuously winged at their distal ends. The tubes are thick, more or less mud-walled to irregularly covered with detritus.

##### *Pista corrientis* McIntosh

*Pista corrientis* McIntosh, 1885, pp. 457-458, pl. 48, fig. 11, pl. 27A, fig. 35; Hesse, 1917, pp. 158-159, pl. 2, figs. 2-3.

*Locality*.—Off Cape Royds, Ross Island, 58 fathoms, Jan. 29, 1948 (1 specimen).

##### *Lanicides vayssierei* (Gravier)

*Terebella (Phyzelia) vayssierei* Gravier, 1911, pp. 130-133, pl. 10, figs. 121-123, pl. 11, figs. 134-135. *Lanicides vayssierei* Hesse, 1917, p. 166-167.

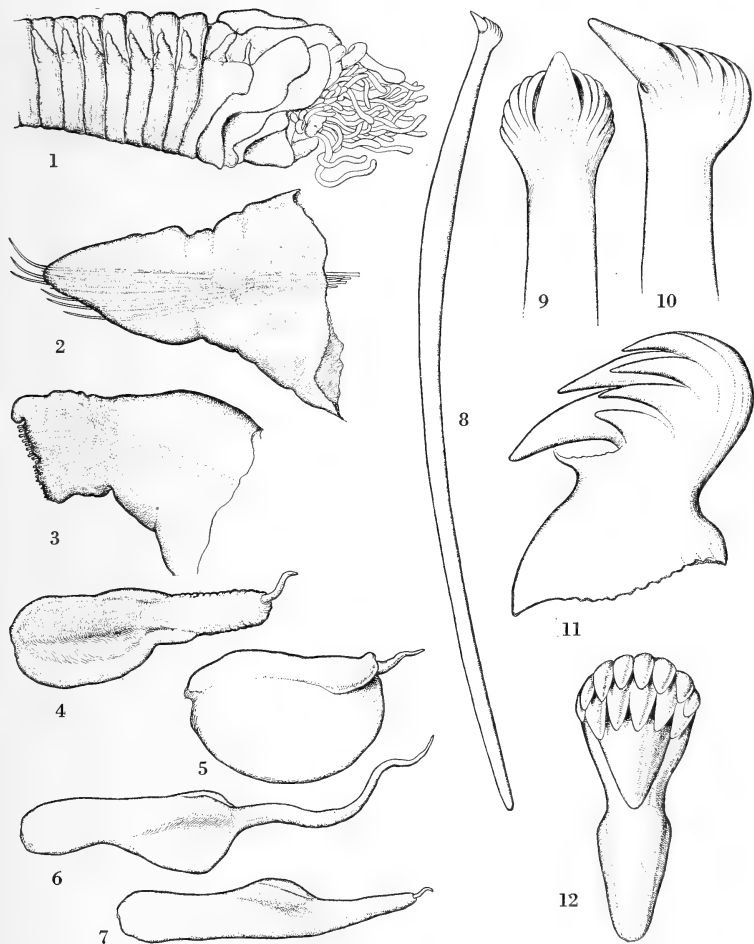

(Reductions in magnifications are made for a base line measuring  $5\frac{1}{2}$  inches.)

FIGS. 1-12. *Octobranthus phyllocomus*, n. sp. (holotype: U. S. N. M. no. 23771): 1, Anterior end seen from the right side,  $\times 7$ ; 2, fourteenth thoracic notopodium,  $\times 49$ ; 3, third abdominal parapodium,  $\times 49$ ; 4, first branchia,  $\times 17.4$ ; 5, second branchia,  $\times 17.4$ ; 6, third branchia,  $\times 17.4$ ; 7, fourth branchia,  $\times 17.4$ ; 8, thoracic uncinus,  $\times 44.3$ ; 9, distal end of thoracic uncinus, seen from front,  $\times 1856$ ; 10, distal end of thoracic uncinus, seen from side,  $\times 1856$ ; 11, abdominal uncinus, seen from side,  $\times 2935$ ; 12, abdominal uncinus, seen from front,  $\times 2935$ .

*Localities*.—Off Cape Royds, Ross Island, 50 fathoms, Jan. 29, 1948 (several specimens); 58 fathoms, Jan. 29, 1948 (many specimens). Marguerite Bay, 35 fathoms, Feb. 20, 1948 (2 specimens); 40 fathoms, Feb. 22, 1948 (many specimens in tubes).

*Notes*.—This is a large species and forms aggregated masses of tubes. Length of the body is 75 mm or more and width is 8 mm. The tubes are considerably larger, to 120 mm long and about 13 mm across; they are composed of a smooth cylindrical lining covered over with fine mud; some have needlelike sponge spicules and other extraneous materials interwoven in the outer layers so that the tube appears irregularly spinous. Conspicuous characters of the species are the two pairs of dendritically branched branchiae, the single pair of large lateral lappets that occur on the second branchial segment, and the two pairs of nephridial papillae present on the posterior side of notopodia 3 and 4. Thoracic segments number 17 setigerous ones. Some of the specimens have the redia stage of a digenetic trematode in the posterior coelomic spaces.

***Leaena ?wandelenis* Gravier**

*Leaena wandelenis* Gravier, 1907, pp. 50-52, pl. 5, figs. 47-48, text figs. 32-34; Benham, 1927, pp. 107-111, pl. 2, figs. 61-69, pl. 6, figs. 189-190.

*Localities*.—Off Cape Royds, Ross Island, 58 fathoms, Jan. 29, 1948 (1 specimen with tube). 65°25' S., 101°13' E., 100 fathoms, Jan. 14, 1948 (1 specimen in tube).

*Notes*.—The larger tube measures about 80 mm long and has many needlelike sponge spicules incorporated with fine detrital materials in its external walls. The smaller tube has proportionately more sponge spicules. Both tubes are long, cylindrical, very slender, and closely fitting the occupant. The thorax has numerous eye spots, limited largely to the sides. There are no branchiae. The oculate area is concealed by a pair of large lateral flaps that extend forward from the next segment. The specific identity is in some doubt since the uncini differ from those originally shown. They are avicular with a main fang that is very large, surmounted by a fang of smaller size and this by several smaller denticles in rostrate arrangement. In this respect they are more nearly like those of *Leaena arenilega* Ehlers (1913, p. 564, pl. 44, fig. 13) from Kaiser Wilhelm-II-Land, a species which Ben-

ham (1927) regards conspecific with *L. wandelenis* Gravier.

***Thelepus cincinnatus* (Fabricius)**

*Amphitrite cincinnata* Fabricius, 1780, pp. 286-287. *Thelepus cincinnatus* Hesse, 1917, pp. 212-214 (with synonymy).

*Localities*.—Off Cape Royds, Ross Island, 58 fathoms, Jan. 29, 1948 (1 specimen). Marguerite Bay, 35 fathoms, Jan. 20, 1948 (2 specimens); 40 fathoms, Jan. 22, 1948 (many specimens).

*Notes*.—The tubes resemble those of *Lanicides vayssierei* (above) but have a tougher lining and are proportionately slenderer. The surface of the body is coarsely granular owing to the presence of epithelial glands. Notopodial setal tufts are present on many segments and continued back to near the posterior end.

***Polycirrus kerguelensis* (McIntosh)**

*Ereutho kerguelensis* McIntosh, 1885, p. 474, pl. 28A, figs. 20, 21. *Polycirrus kerguelensis* Hesse, 1917, pp. 221-224.

*Locality*.—Marguerite Bay, 40 fathoms, Feb. 22, 1948 (1 specimen).

*Notes*.—The single individual is about 18 mm long; it has 11 thoracic setigerous segments, as Hesse found, not 13 as described by McIntosh. There are three long, digitate nephridial lobes on each side of setigerous segments 4, 5, and 6.

Family SABELLIDAE

***Euchone pallida* Ehlers**

*Euchone pallida* Ehlers, 1908, p. 159, pl. 21, figs. 10-15, pl. 22, figs. 1-4.

*Localities*.—Off Cape Royds, Ross Island, 50 fathoms, Jan. 29, 1948 (1 specimen); 58 fathoms, Jan. 29, 1948 (3 specimens with tubes).

***Potamilla antarctica* (Kinberg)**

*Laonome antarctica* Kinberg, 1867, p. 354. *Potamilla antarctica* Gravier, 1907, pp. 59-62, figs. 38-43.

*Localities*.—Off Burton Rock, 66°15' S., 95°20' E., 43 fathoms, Jan. 3, 1948 (1 specimen). Off Cape Royds, Ross Island, 58 fathoms, Jan. 29, 1948 (several specimens in tubes). Off Point #13 Island, Knox coast, 66°31' S., 110°26' E., 110 fathoms, Jan. 19, 1948 (1 specimen). Marguerite Bay, 35 fathoms, Feb. 20, 1948 (1 specimen); 40 fathoms, Feb. 22, 1948 (1 specimen).

*Notes*.—Some of the larger individuals meas-



ure about 160 mm long. The tubes are translucent, horny, and cylindrical and measure about 200 mm long at most; they closely surround the occupant and taper posteriorly to a conical closed end. In the larger specimens the pygidial lobe is pale white, with few or no dark eye spots; in smaller, presumably younger individuals of the same species the terminal lobe has many irregularly strewn reddish or dark eye spots. The thorax has eight setigerous and the abdomen 100 or more segments. The tentacular radioles are very long, numerous, 25 to 30 on a side; each terminates distally in a long, smooth tip that surpasses the length of the individual filaments. The thoracic collar lacks dorsal lobes; it has lateral lobes and long, oblique ventral ends. Thoracic notosetae are of 2 kinds; the superior ones are longer and slenderer than the abruptly different, mucronated inferior ones.

#### Family SERPULIDAE

##### *Serpula vermicularis narconensis* Baird

*Serpula narconensis* Baird, 1865, p. 21, pl. 2, figs. 7, 8.

*Serpula vermicularis* Gravier, 1911, pp. 147-148, pl. 12, figs. 170-175.

*Localities*.—66°35' S., 90°40' E., 150 fathoms, Dec. 30, 1947 (several tubes). Off Cape Royds, Ross Island, 58 fathoms, Jan. 29, 1948 (many tubes). Off Point #13 Island, Knox coast, 110 fathoms, Jan. 19, 1948 (2 tubes). Marguerite Bay, 115 fathoms, Feb. 18, 1948 (tube fragments); 85-105 fathoms, Feb. 19, 1948 (several tubes); 35 fathoms, Feb. 19-20, 1948 (many tubes); 40 fathoms, Feb. 22, 1948 (several specimens with tubes).

##### *Spirorbis* spp.

*Locality*.—Off Cape Royds, Ross Island, 58 fathoms, Jan. 29, 1948 (several specimens).

*Notes*.—There are several coiled tubes, adherent to those of *Serpula vermicularis narconensis* (above) and algal strands. The aperture is sinistral; the upper surface has three longitudinal ridges. The individual coils measure 1 or 2 mm across.

#### REFERENCES

BAIRD, W. *Description of several new species and varieties of tubicolous Annelides, in the collection of the British Museum*. Journ. Linn. Soc. Zool. London **8**: 10-22, 2 pls. 1865.

BENHAM, W. B. *Polychaeta*. British Antarctic Terra Nova Expedition, 1910. Nat. Hist. Rep. Zool. **7**: 47-182, 6 pls. 1927.

BERGSTRÖM, E. *Zur Systematik des Polychaeten Familie der Phyllodociden*. Zool. Bidr. Uppsala **3**: 37-224, 81 figs. 1914.

———. *Die Polynoiden des schwedischen Südpolar-Expedition 1901-1903*. Ibid. **4**: 249-304, pls. 2-5, 2 text figs. 1916.

EHLERS, E. *Polychaeten*. Hamburger Magalhaensischen Sammelreise, 148 pp., 9 pls. 1897.

———. *Die Polychaeten des magellanischen und chilenischen Strandes*. Festschr. Ges. Wiss. Göttingen, 232 pp., 25 pls. Berlin, 1901.

———. *Wissenschaftliche Ergebnisse der deutschen Tiefsee-Expedition auf dem Dampfer Valdivia 1898-1899* **16**(1): 168 pp., 23 pls. 1908.

———. *Die Polychaeten-Sammlungen der deutschen Südpolar-Expedition 1901-03*. Deutsche Südpolar-Exped. **13**(4): 397-598, pls. 26-46. 1913.

FABRICIUS, O. *Fauna Groenlandica*, xvi + 452 pp. Hafniae et Lipsiae, 1780.

GRAVIER, C. *Sur les Annelides polychètes recueillies par l'Expedition Antarctique française*, 75 pp., 5 pls., 46 text figs. Paris, 1907.

———. *Annelides polychètes recueillies par la seconde expedition antarctique française (1908-1910)*. Deuxième Expedition Antarctique Française **1**: 165 pp., 12 pls. 1911.

GRUBE, A. E. *Beschreibung neuer oder wenig bekannter Anneliden*. Beitrag: Zahlreiche Gattungen. Arch. Naturg. Berlin **29**(1): 37-69, 3 pls. 1863.

HARTMAN, OLGA. *The marine annelids erected by Kinberg with notes on some other types in the Swedish State Museum*. Ark. Zool. Stockholm **42A**: 1-137, 18 pls. 1948.

———. *Polychaetous Annelids: Goniadidae, Glyceridae, Nephtyidae*. Allan Hancock Pacific Exped. **15**: 1-181, 19 pls., 3 text figs. 1950.

HESSLE, C. *Zur Kenntnis der terebellomorphen Polychaeten*. Zool. Bidr. Uppsala **5**: 39-258, 5 pls., 66 text figs. 1917.

KINBERG, J. G. H. *Nya slågten och arter af Annelider*. Öfv. Vet.-Akad. Stockholm **12**: 381-388. 1855.

———. *Annulata nova*. Ibid. **21**: 559-574. 1865; **22**: 167-179 and 239-258. 1866; **23**: 337-357. 1867.

———. *Kongliga Svenska Fregatten Eugénies Resa omkring jorden under befäl af C.A. Virgin åren 1851-53*. Zoologi, 3 Annulater, 78 pp., 29 pls. 1910.

MCINTOSH, W. C. *Report on the Annelida Polychaeta collected by H.M.S. Challenger during the years 1873-76*. Challenger Reports **12**: 1-554, pls. 1-55 and 1A-39A. 1885.

MONRO, C. C. A. *Polychaete worms*. Discovery Reports **2**: 1-222, 91 figs. 1930.

———. *Polychaete worms. II*. Ibid. **12**: 59-198, 34 figs. 1936.

SCHMARDA, L. *Neue wirbellose Thiere beobachtet und gesammelt auf einer Reise um die Erde 1853 bis 1857* **1**(2): 1-164, 22 pls. Leipzig. 1861.

WILLEY, A. *Polychaeta*. Report on the collections of natural history made in the Antarctic regions during the voyage of the Southern Cross **12**: 262-283, pls. 41-46. London, 1902.

NEMATOLOGY.—A new roundworm, *Capillaria pirangae* (Nematoda: Trichinelidae), from the scarlet tanager, *Piranga erythromelas*. CHARLES G. DURBIN, U. S. Bureau of Animal Industry. (Communicated by E. W. Price.)

Two males and one mature female nematodes of the genus *Capillaria* were recovered from the small intestine of a scarlet tanager, *Piranga erythromelas*, caught at the Agricultural Research Center, Beltsville, Md.

An examination of the specimens of *Capillaria* in the U. S. National Museum Helminthological Collection showed no specimens that had been obtained from the scarlet tanager, and a review of the pertinent literature (Cram, 1925; Teixeira de Freitas and Luis de Almeida, 1934, 1935; Madsen, 1945, 1951; Lopez-Neyra, 1947) shows that, except for Read's (1949) report, there are no records of any capillarids having been collected from this host. Read (*loc. cit.*) reported finding two immature female capillarids in the small intestine of a scarlet tanager at Madison and Shawano, Wis. He was unable to determine the species because the specimens were immature. However, a study of Read's description and illustrations shows clearly that the capillarids collected from the scarlet tanager in Wisconsin differ from those that form the subject of the present note.

*Capillaria pirangae*, n. sp.

*Description*.—Cuticle transversely striated. Lateral bacillary lines present. Mouth simple.

*Male*.—13 mm long, maximum width 55  $\mu$ . Spicule smooth with a blunt tip, 1.55 mm long by 15  $\mu$  wide; spicule sheath covered with minute spines. Lateral caudal alae absent. The tail ends in a bilobed membranous bursa, each lobe supported by a stout ray (Fig. 1, B). Cloaca subterminal.

*Female*.—18 mm long by 50  $\mu$  wide just anterior to the vulva; maximum width 65  $\mu$ . No prevulvar notch or cuticular bosses present. Well-developed funnel shaped vulvar appendage present (Fig. 1, A). Anus subterminal. Vulva divides the body 1:2.2. Eggs, 60–65  $\mu$  long; 25–30  $\mu$  wide; outershell with longitudinal folds (Fig. 1, A).

*Host*.—*Piranga erythromelas*.

*Location*.—Small intestine.

*Locality*.—Beltsville, Md.

*Type specimens*.—Female, holotype; male, allotype U. S. N. M. Helm. Coll. no. 46938.

*Remarks*.—The female most closely resembles *C. quisquali* Read, 1949, but differs from it in the shape of the vulvar appendage. In *C. quisquali* the base of the vulvar appendage is long and elevated whereas in *C. pirangae* the base of the appendage is narrow. The surface of the eggs of *C. quisquali* are roughly mammilated whereas those of *C. pirangae* have longitudinal folds. The male bears

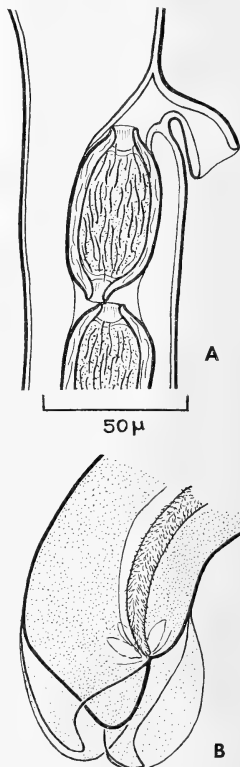

FIG. 1.—*Capillaria pirangae*, n. sp.; A, Female, region of vulva, egg in uterus; B, male, tail.

some resemblance to *C. collaris* (v. Linstow, 1873), but differs from it in the shape of the spicule and the absence of a spine on its tip.

## REFERENCES

- CRAM, ELOISE B. *Species of Capillaria parasitic in the upper digestive tract of birds*. U. S. Dept. Agr. Techn. Bull. 516: 27 pp., pls. 1936.
- LOPEZ-NEYRA, C. R. *Generos y especies nuevas o mal conocidas de Capillariinae*. Rev. Iber. Parasitol. 7 (2): 191-238. 1947.
- MADSEN, H. *The species of Capillaria (Nematodes, Trichinelloidea) parasitic in the digestive tract of Danish gallinaceous and anatine game birds, with a revised list of species of Capillaria in birds*. Danish Rev. Game Biol. 1 (1): 1-112, 21 fig. 1945.

———. *Notes on the species of Capillaria Zeder 1800 known from gallinaceous birds*. Journ. Parasitol. 37 (3): 257-265. 1951.

READ, CLARK, P. *Studies on North American helminths of the genus Capillaria Zeder, 1800 (Nematoda): III. Capillarids from the lower digestive tract of North American birds*. Journ. Parasitol. 35: (3): 240-249. 1949.

TEIXERA DE FREITAS, J. F., and LINS DE ALMEIDA, J. *Sobre os Nematoda Capillariinae parasitas de esophago e papo de aves*. Mem. Inst. Oswaldo Cruz 30 (2): 123-156. 1935.

———. *O genero "Capillaria" Zeder 1800 ("Nematoda-Trichuroidea") e as Capillarioses nas aves domesticas*. Rev. Dept. Nac. Prod. Animal Brasil 2 (4, 5, 6): 310-363, pls. 1935.

HERPETOLOGY.—*A new Philippine snake of the genus Calamaria*. ALAN E. LEVITON, Natural History Museum, Stanford University. (Communicated by Doris M. Cochran.)

Several years ago while identifying the snakes collected by Dr. Albert W. Herre during his Philippine Expedition of 1940, I noted a specimen belonging to the genus *Calamaria* that was not identifiable with any previously described species, and appeared to be a new form. I decided not to describe the new snake immediately but to wait until it would be possible to review the entire genus, rather than add to the existing confusion. Plans were outlined to study the genus as a whole, but inasmuch as completion of a generic review must now be postponed because of inadequacy of available material, it seems best to publish a description of this snake without further delay.

*Calamaria zamboangensis*, n. sp.

*Holotype*.—SU reptile register no. 13476, male, collected by Dr. Albert W. Herre, at Zamboanga, Mindanao Island, Philippine Islands, September 2, 1940, during the Herre Oriental Expedition of 1940.

*Paratype*.—SU 13477; same data as holotype except as otherwise mentioned.

*Diagnosis*.—This species can be distinguished from all previously described forms of *Calamaria* by the combination of the following characteristics: Mental shield not in contact with anterior genials, diameter of eye less than its distance to mouth, frontal only twice as broad as supra-

ocular, preocular and postocular shields present, anal entire. *C. zamboangensis* is distinguished from *albopunctata* by a considerably lower ventral count (201-203 V. in *zamboangensis*, 247 V. in *albopunctata*), and from *quinquetaeniata* by a higher ventral and lower subcaudal count (*zamboangensis*, 201-203 V., 12-13 C.; *quinquetaeniata*, 178 V., 26 C.). It differs from *egregia* in the smaller proportions of the frontal shield width vs. supraocular shield width, the smaller number of subcaudal shields, five supralabials, and by the unequal size of the third and fourth supralabials (*egregia* has the frontal shield three times the width of the supraocular, 16 subcaudal shields, 6 supralabials, and the fourth upper labial smaller than the third); and from *brachyura* by the smaller eye and different coloration.

*Description*.—Diameter of the eye distinctly less than its distance from the mouth; rostral broader than deep; internasals absent. The frontal is slightly longer than wide, twice as broad as the supraocular, somewhat shorter than the parietals. There are five supralabials, the third and fourth entering the eye and subequal in size. The first and second upper labials in contact with the prefrontal, the fifth with the parietal. Nostril in a small nasal; loreal absent; 1 preocular and 1 postocular; temporals absent. The mental shield is not in contact with the anterior chin shields, the first infralabial meeting its fellow behind the mental. There are five infra-

labials, the first three in contact with the anterior chin-shield; the posterior chin-shields smaller than and in contact with the anterior shields.

Ventrals 201-203 (holotype 201); subcaudals 12-13 (holotype 12); anal single; scales in 13-13-13 rows.

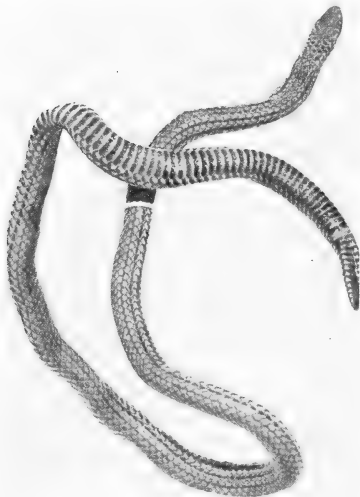

FIG. 1.—Holotype of *Calamaria zamboangensis*, S.U. no. 13476. (Photograph by Antenor L. de Carvalho and the author.)

*Coloration* (specimen preserved in formalin and then in alcohol).—The ground color is light brown; there are six dark brown stripes dorsally formed by a series of coalescing spots. These stripes are distributed as follows: One between the first and second scale rows, one on the third row, one between the fourth and fifth rows. Immediately behind the head and extending for about one fifth of the body length there are two additional stripes (longitudinal series of spots), one on the sixth scale row and one on the eighth row, but these fade out rapidly on the body. The head is more or less uniform brown, this color extending onto the upper edges of the supralabials; the remainder of the supralabials are yellowish brown.

Ventrally the throat and anterior portion of the body are uniform light yellow-brown. About one-fifth of the body length posterior to the head the inner edges of the ventrals become darker brown while the outer edges remain a light color. This pattern extends onto the tail. There is a median dark line running down the length of the tail.

*Measurements* (holotype).—Total length 248 mm, snout to vent 237 mm, tail length 11 mm.

*Remarks*.—The paratype agrees with the holotype in the color pattern, although its color has faded considerably.

*C. zamboangensis* appears to be closely related to *C. egregia* Barbour but can readily be distinguished from this species as shown in the diagnosis. With the accumulation of additional evidence this new species may prove to be conspecific with *egregia*, but unfortunately the lack of material prevents the determination of the exact relationship between these two species.

There are three other species of *Calamaria* to which the new form bears a resemblance—*everetti*, *virgulata*, and *occipitalis*. However, these three species can be distinguished from *zamboangensis* as follows: *everetti* has the diameter of the eye greater than its distance from the mouth, *virgulata* has the diameter of the eye equal to its distance from the mouth and a somewhat different coloration, and *occipitalis* which has a divided anal plate.

*Acknowledgments*—I express my sincere thanks to Dr. Walter C. Brown, of Northwestern University, who has been kind enough to reexamine a considerable portion of the data presented here, to Prof. George S. Myers, of Stanford University, for reading the manuscript and offering some valuable criticisms, and to Charles M. Bogert for the loan of the entire collection of *Calamaria* in the American Museum of Natural History for study and comparison.

#### BIBLIOGRAPHY

- BARBOUR, THOMAS. *Two new Bornean snakes*. Proc. Biol. Soc. Washington 40: 127-128. 1927.
- DE ROOIJ, NELLY. *The reptiles of the Indo-Australian Archipelago 2: Ophidia*: XIV + 334 pp., 117 figs. Leiden, 1917.
- TAYLOR, EDWARD HARRISON. *The snakes of the Philippine Islands*. Philippine Bur. Sci. Publ. 16: 312 pp., 32 figs., 37 pls. 1922.

## Officers of the Washington Academy of Sciences

*President*.....WALTER RAMBERG, National Bureau of Standards  
*President-elect*.....F. M. SETZLER, U. S. National Museum  
*Secretary*.....F. M. DEFANDORF, National Bureau of Standards  
*Treasurer*.....HOWARD S. RAPPELBYE, U. S. Coast and Geodetic Survey  
*Archivist*.....JOHN A. STEVENSON, Plant Industry Station  
*Custodian and Subscription Manager of Publications*  
..... HARALD A. REHDER, U. S. National Museum

### *Vice-presidents Representing the Affiliated Societies:*

Philosophical Society of Washington.....A. G. McNISH  
Anthropological Society of Washington.....WALDO R. WEDEL  
Biological Society of Washington.....HUGH T. O'NEILL  
Chemical Society of Washington.....JOHN K. TAYLOR  
Entomological Society of Washington.....FREDERICK W. POOS  
National Geographic Society.....ALEXANDER WETMORE  
Geological Society of Washington.....A. NELSON SAYRE  
Medical Society of the District of Columbia.....FRED O. COE  
Columbia Historical Society.....GILBERT GROSVENOR  
Botanical Society of Washington.....LEE M. HUTCHINS  
Washington Section, Society of American Foresters.....WILLIAM A. DAYTON  
Washington Society of Engineers.....CLIFFORD A. BETTS  
Washington Section, American Institute of Electrical Engineers.....A. H. SCOTT  
Washington Section, American Society of Mechanical Engineers.....RICHARD S. DILL  
Helminthological Society of Washington.....L. A. SPINDLER  
Washington Branch, Society of American Bacteriologists.....ANGUS M. GRIFFIN  
Washington Post, Society of American Military Engineers.....FLOYD W. HOUGH  
Washington Section, Institute of Radio Engineers.....HERBERT G. DORSEY  
District of Columbia Section, American Society of Civil Engineers  
..... MARTIN A. MASON  
District of Columbia Section, Society for Experimental Biology and Medicine  
..... N. R. ELLIS

### *Elected Members of the Board of Managers:*

To January 1953.....C. F. W. MUESEBECK, A. T. MCPHERSON  
To January 1954.....SARA E. BRANHAM, MILTON HARRIS  
To January 1955.....ROGER G. BATES, W. W. DIEHL

*Board of Managers*.....All the above officers plus the Senior Editor  
*Board of Editors and Associate Editors*.....[See front cover]

*Executive Committee*.....WALTER RAMBERG (chairman), F. M. SETZLER, H. S. RAPPELBYE,  
WILLIAM A. DAYTON, F. M. DEFANDORF

*Committee on Membership*.....E. H. WALKER (chairman), M. S. ANDERSON, CLARENCE COT-  
TAM, R. C. DUNCAN, JOHN FABER, G. T. FAUST, I. B. HANSEN, FRANK KRACEK, D. B.  
JONES, E. G. REINHARD, REECE I. SAILER, LEO A. SHINN, F. A. SMITH, HEINZ SPECHT,  
H. M. TRENT, ALFRED WEISSLER

*Committee on Meetings*.....H. W. WELLS (chairman), WM. R. CAMPBELL, W. R. CHAP-  
LINE, D. J. DAVIS, H. G. DORSEY, O. W. TORRESON

*Committee on Monographs* (W. N. FENTON, chairman):  
To January 1953.....R. W. IMLAY, P. W. OMAN  
To January 1954.....S. F. BLAKE, F. C. KRACEK  
To January 1955.....W. N. FENTON, ALAN STONE

*Committee on Awards for Scientific Achievement* (J. R. SWALLEN, general chairman):

*For Biological Sciences*.....J. R. SWALLEN (chairman), L. M. HUTCHINS,  
MARGARET PITTMAN, F. W. POOS, L. P. SCHULTZ

*For Engineering Sciences*.....R. C. DUNCAN (chairman), A. C. FIELDNER,  
WAYNE C. HALL, J. W. MCBURNEY, O. S. READING, H. L. WHITEMORE

*For Physical Sciences*.....L. A. WOOD (chairman), P. H. ABELSON,  
F. S. DAFT, GEORGE W. IRVING, JR., J. H. McMILLEN

*For Teaching of Science*.....M. A. MASON (chairman), F. E. FOX, M. H. MARTIN

*Committee on Grants-in-aid for Research*.....L. E. YOCUM (chairman), H. N. EATON,  
K. F. HERZFELD

### *Committee on Policy and Planning:*

To January 1953.....W. A. DAYTON (chairman), N. R. SMITH  
To January 1954.....H. B. COLLINS, JR., W. W. RUBEY  
To January 1955.....L. W. PARR, F. B. SILSBEE

*Committee on Encouragement of Science Talent* (A. T. MCPHERSON, chairman):

To January 1953.....A. H. CLARK, F. L. MOHLER  
To January 1954.....J. M. CALDWELL, W. L. SCHMITT  
To January 1955.....A. T. MCPHERSON, W. T. READ

*Representative on Council of A. A. A. S.*.....F. M. SETZLER

*Committee of Auditors*.....C. L. GAZIN (chairman), LOUISE M. RUSSELL, D. R. TATE

*Committee of Tellers*.....GEORGE P. WALTON (chairman), GEORGE H. COONS, C. L. GARNER

## CONTENTS

	Page
GEOLOGY.—Lower limit of the Cambrian in the Cordilleran region. CHESTER R. LONGWELL.....	209
PALEONTOLOGY.—Remains of Devonian fishes from Texas. DAVID H. DUNKLE and JOHN A. WILSON.....	213
PALEONTOLOGY.—Notes on <i>Texacrinus</i> . HARRELL L. STRIMPLE.....	216
ENTOMOLOGY.—The Ethiopian genera of Sarginae, with descriptions of new species. MAURICE T. JAMES.....	220
ENTOMOLOGY.—New names in the Homoptera. Z. P. METCALF.....	226
ZOOLOGY.—The marine annelids of the United States Navy Antarctic Expedition, 1947-48. OLGA HARTMAN.....	231
NEMATODOLOGY.—A new roundworm, <i>Capillaria pirangae</i> (Nematoda: Trichinellidae), from the scarlet tanager ( <i>Piranga erythromelas</i> ). CHARLES G. DURBIN.....	238
HERPETOLOGY.—A new Philippine snake of the genus <i>Calamaria</i> . ALAN E. LEVITON.....	239

JOURNAL  
OF THE  
WASHINGTON ACADEMY  
OF SCIENCES

BOARD OF EDITORS

WILLIAM F. FOSHAG  
U.S. NATIONAL MUSEUM

J. P. E. MORRISON  
U.S. NATIONAL MUSEUM

JOHN C. EWERS  
U.S. NATIONAL MUSEUM

ASSOCIATE EDITORS

F. A. CHACE, JR.  
BIOLOGY

J. I. HOFFMAN  
CHEMISTRY

T. P. THAYER  
GEOLOGY

MIRIAM L. BOMHARD  
BOTANY

R. K. COOK  
PHYSICS AND MATHEMATICS

PHILIP DRUCKER  
ANTHROPOLOGY

C. W. SABROSKY  
ENTOMOLOGY

PUBLISHED MONTHLY  
BY THE  
WASHINGTON ACADEMY OF SCIENCES  
MOUNT ROYAL & GUILFORD AVES.  
BALTIMORE, MARYLAND

Entered as second class matter under the Act of August 24, 1912, at Baltimore, Md.  
Acceptance for mailing at a special rate of postage provided for in the Act of February 28, 1925.  
Authorized February 17, 1949



## Journal of the Washington Academy of Sciences

This JOURNAL, the official organ of the Washington Academy of Sciences, publishes: (1) Short original papers, written or communicated by members of the Academy; (2) proceedings and programs of meetings of the Academy and affiliated societies; (3) notes of events connected with the scientific life of Washington. The JOURNAL is issued monthly. Volumes correspond to calendar years.

*Manuscripts* may be sent to any member of the Board of Editors. It is urgently requested that contributors consult the latest numbers of the JOURNAL and conform their manuscripts to the usage found there as regards arrangement of title, subheads, synonymies, footnotes, tables, bibliography, legends for illustrations, and other matter. Manuscripts should be typewritten, double-spaced, on good paper. Footnotes should be numbered serially in pencil and submitted on a separate sheet. The editors do not assume responsibility for the ideas expressed by the author, nor can they undertake to correct other than obvious minor errors.

*Illustrations* in excess of the equivalent (in cost) of one full-page halftone are to be paid for by the author.

*Proof.*—In order to facilitate prompt publication one proof will generally be sent to authors in or near Washington. It is urged that manuscript be submitted in final form; the editors will exercise due care in seeing that copy is followed.

*Unusual cost* of foreign, mathematical, and tabular material, as well as alterations made in the proof by the author, may be charged to the author.

*Author's Reprints.*—Reprints will be furnished in accordance with the following schedule of prices (approximate):

Copies	4 pp.	8 pp.	12 pp.	16 pp.	20 pp.	Covers
100	\$3.25	\$6.50	\$ 9.75	\$13.00	\$16.25	\$3.00
200	6.50	13.00	19.50	26.00	32.50	6.00
300	9.75	19.50	29.25	39.00	48.75	9.00
400	13.00	26.00	39.00	52.00	65.00	12.00

*Subscriptions* or requests for the purchase of back numbers or volumes of the JOURNAL or the PROCEEDINGS should be sent to HARALD A. REHDER, Custodian and Subscription Manager of Publications, U. S. National Museum, Washington 25, D. C.

*Subscription Rates* for the JOURNAL.—Per year..... \$7.50

Price of back numbers and volumes:	Per Vol.	Per Number
Vol. 1 to vol. 10, incl.—not available*.....	—	—
Vol. 11 to vol. 15, incl. (21 numbers per vol.).....	\$10.00	\$0.70
Vol. 16 to vol. 22, incl. (21 numbers per vol.).....	8.00	0.60
Vol. 23 to current vol. (12 numbers per vol.).....	7.50	0.90

\* Limited number of complete sets of the JOURNAL (vol. 1 to vol. 41, incl.) available for sale to libraries at \$348.50.

MONOGRAPH No. 1, "The Parasitic Cuckoos of Africa," by Herbert Friedmann. \$4.50

PROCEEDINGS, vols. 1-13 (1899-1911) complete..... \$25.00

Single volumes, unbound..... 2.00

Single numbers..... .25

*Missing Numbers* will be replaced without charge provided that claim is made to the Treasurer within 30 days after of following issue.

*Remittances* should be made payable to "Washington Academy of Sciences" and addressed to the Treasurer, H. S. RAPPLEYE, 6712 Fourth Street, N.W., Washington 12, D.C.

*Exchanges.*—The Academy does not exchange its publications for those of other societies.



# JOURNAL OF THE WASHINGTON ACADEMY OF SCIENCES

VOLUME 42

August 1952

No. 8

GEOLOGY.—*The Murphree Valley anticline, Alabama.*<sup>1</sup> GEORGE W. STOSE, U. S. Geological Survey.

In studying the manganese deposits of Walnut Grove, Ala., surveyed for the U. S. Geological Survey in 1942, I had occasion to map the north end of the Murphree Valley anticline, from Oneonta northeastward. As the structure of this fold differs in direction of overturning and thrusting from typical broken folds of the Southern Appalachians, it was the subject of discussion at a meeting of geologists of the Southern States held at the University of Kentucky, Lexington, Ky., March 23–25, 1950. Therefore I wish to record my determination of the structure.

This anticline in the Appalachian Plateau is an exception to structures common to the Southern Appalachian region in that it is overturned to the southeast and is bordered on its southeast side by a thrust fault that is steeply inclined to the northwest. This structure was so shown on the section in the Gadsden Folio of the Geologic Atlas of the United States (Hayes, 1896), on a section of the Geologic Map of Alabama (Butts, 1926), and in other reports. The rocks at the surface that are involved in the structure range in age from Upper Cambrian to Pennsylvanian, and the succession of formations is shown in the legend of the map, Fig. 1. The terminology used is that of Butts (1926) rather than that of Hayes (1896). The formations, in descending order, are briefly characterized in the following description.

A sandstone unit at the base of the Pottsville formation of Pennsylvanian age (the Lookout sandstone of Hayes) forms the ridges that border the anticline—Sand Mountain on the northwest border and

Raccoon Mountain, which passes north-eastward into Straight Mountain, on the southeast. The Pennington shale of Mississippian age underlies the Pottsville, and is very thin in this part of Alabama. In the Murphree Valley this formation is partly sandstone. The Bangor limestone is a fossiliferous, cliff-making limestone about 600 feet thick. Fossils collected from it include *Pentremites*, *Archimedes*, zaphrentoid corals, gastropods, and brachiopods of Chester age. The Tuscombina limestone, largely weathered to clay and chert, in this area contains many lentils and thick beds of sandstone (Fig. 1), including one northwest of Walnut Grove that makes a cliff 60 feet high. Such lentils were evidently formed by detrital matter from deltas of streams that entered the sea in this vicinity. Many specimens of *Fenestella* and branching bryozoans, of St. Louis age, are present in the formation, and the base is marked by beds that contain *Lithostrotionella* (*Lithostrotion canadense* of old reports). The Fort Payne chert, the manganese-bearing formation of the area, is characterized by many large crinoid segments and large spirifers of Keokuk age. Probably some fossiliferous chert of the overlying Tuscombina has been included in the mapping of the Fort Payne chert, especially in the area northeast of Aurora, where beautifully preserved bryozoans, including fenestellas of Warsaw age, were collected. The Fort Payne chert, about 200 feet thick, is composed of interbedded chert and limestone, commonly with a prominent sandstone at the base. The limestone has weathered to clay, which contains the manganese deposits. These deposits are limited in distribution to about 5 miles along the strike of the formation.

<sup>1</sup> Publication authorized by the Director, U. S. Geological Survey.

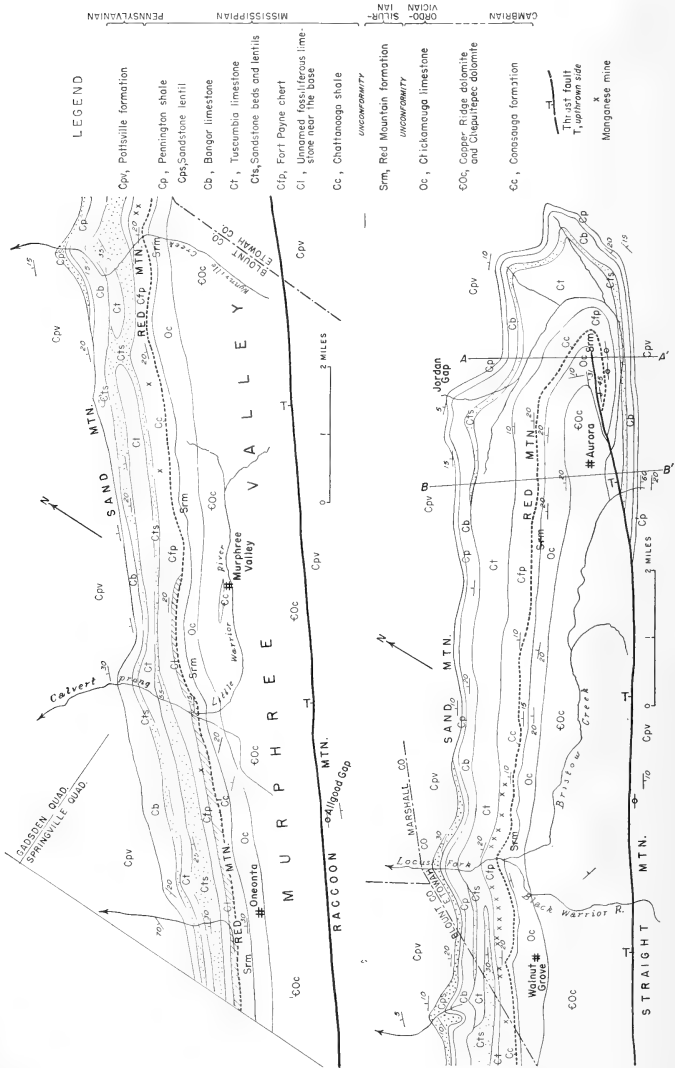

FIG. 1.—Geologic map of northern part of Murphree Valley anticline, Alabama.

The ore is in thin beds, which swell to 6 inches in places. Most of the commercial ore is pulverulent pyrolusite of high grade. A limestone 55 feet thick, locally present in the lower part of the formation northwest of Oneonta, resembles limestone described by Butts (1926, p. 164) from Lauderdale County, from which he identified fossils of Burlington age. Fossils collected in this limestone in the Murphree Valley northwest of Oneonta were briefly examined by J. S. Williams of the U. S. Geological Survey, who states that they appear to be of post-Burlington age, possibly Keokuk.

The Chattanooga shale, 20 to 40 feet in thickness, is chiefly black carbonaceous shale containing linguloid shells and conodonts, which Ulrich considered to be identical with forms that occur in the Sunbury shale of Ohio and therefore of Carboniferous age (Ulrich, 1911, pl. 28 and p. 527). Unfossiliferous gray sandy beds in the lower part of the formation may be Devonian in age. The Red Mountain formation, which forms Red Mountain, lies directly beneath the Chattanooga shale and crops out near the center of the anticline. As its name implies, the formation is red, owing to the presence of hematite and red shale of Clinton age. The underlying Chickamauga limestone is largely a pure limestone and includes beds ranging in age from Maysville to "Stones River" (Chazyan) (Ulrich, 1911, pl. 27 and pp. 566-567). At the base are dark limestones that contain bryozoans, brachiopods, and gastropods, which Ulrich regarded as the Stones River fauna. The Copper Ridge dolomite lies in the lowland of the valley, where it is weathered to clay and chert. No fossils were collected from it. Butts (1926) refers the formation to the Upper Cambrian. At Chepultepec (now

Allgood) on the west side of the Murphree Valley, about 5 miles southwest of Oneonta, fossils of Lower Ordovician age were collected by Ulrich from chert of the Chepultepec dolomite which overlies the Copper Ridge dolomite. The Chepultepec dolomite was not observed in the area shown in the map, Fig. 1, but is probably present. Thin-bedded limestones that are exposed near the village of Murphree Valley weather to buff and light-colored earthy shale and tripoli and closely resemble the limestones of the Elbrook formation of Virginia and farther north. These rocks are tentatively mapped as Conasauga formation.

From Oneonta northeastward the fault in the Murphree Valley is on the southeast side of the anticline, and lies between the Copper Ridge dolomite on the west and the Pottsville formation on the east. At Allgood Gap in Raccoon Mountain, southeast of Oneonta, the Pottsville at the fault is vertical and the Copper Ridge dolomite is exposed in the adjacent lowland to the west. The Pottsville formation of Straight Mountain, southeast of Walnut Grove, also stands vertical at the fault, but away from the fault it rapidly assumes a gentle southeast dip. A mile and a half southeast of Aurora the fault passes into lower beds of the anticline and dies out in the northeast plunging end. Southwest of Oneonta the fault similarly passes into lower beds of the anticline, which here plunges southwestward, as shown on the Alabama geological map (Butts, 1926). The exposures southeast of Aurora, where the thrust passes into lower beds in the anticline, furnish the best place to study the fault. A mile south of Aurora the fault leaves the contact with the Pottsville formation and passes into lower beds in the anticline, through Pennington shale,

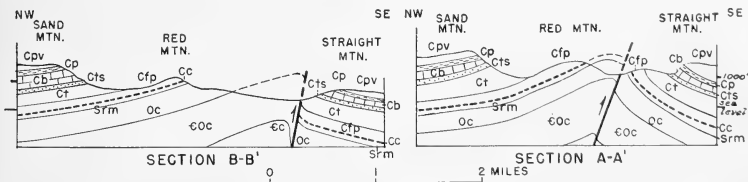

FIG. 2.—Cross-sections of Murphree Valley anticline on the lines A-A' and B-B' of Fig. 1.

Bangor limestone, Tuscumbia limestone, Fort Payne chert, Chattanooga shale, into the Red Mountain formation, where displacement dies out to the northeast. The mapping of this part of the fold on the geological map of Alabama (Butts, 1926) evidently was copied from Hayes' mapping, and the changes shown are probably due to inaccuracies of copying and not to correction by Butts. The same is probably true of the fault on the southeast side of the Murphree Valley on section B-B' of that map, which is shown by Butts—much less steep than by Hayes.

The strata exposed near the fault along and adjacent to the road northeast from Aurora (Figs. 1 and 2-AA') are mostly vertical, and at one place the Red Mountain formation just east of the fault is overturned and dips 45° NW. The Chickamauga limestone, which crops out northwest of the fault, is also overturned and dips 65° NW. The fault plane is nowhere exposed, but at the plunging end of the anticline the beds close to the fault are seen to be largely vertical or are overturned and dip steeply northwestward, and the fault probably has a similar steep dip. The fold and the thrust are believed by the writer to be superficial, produced by the abrupt upbowing of the Copper Ridge dolomite, which is the competent bed that directly underlies this part of the anticline.

The Murphree Valley anticline is an uplift in the Appalachian Plateau between the Sequatchie-Browns Valley anticline to the northwest and the Wills Valley anticline to the southeast (Fig. 3). The bordering syn-

clines are nearly flat, wide folds of gently rolling Carboniferous rocks, from which the three narrow, straight anticlines rise abruptly and are exposed in narrow valleys carved in the plateau surface. They lie just west of the Allegheny Front and west of the Appalachian folded belt. These anticlines are believed by the writer to have been formed by the abrupt yielding to pressure and the local upbowing of the thick Copper Ridge dolomite, the competent bed that transmitted the thrust from its source to the southeast. Each of the three anticlines is broken by a thrust fault along its trend. The rocks of the Sequatchie-Browns Valley anticline and the Wills Valley anticline have steeper dips on their northwest sides where they are broken by thrust faults dipping steeply southeastward. The Murphree Valley anticline also is broken by a thrust fault on its steeper side, which, however, is the southeast side. The Copper Ridge dolomite beneath the Carboniferous rocks of the synclines is nearly horizontal and transmitted the thrust in a horizontal direction. I believe that the dolomite bowed up into sharp, steep anticlines, while the underlying, nonresistant shaly Conasauga formation yielded to the pressure by crumpling. The anticlines and the thrust faults, therefore, are superficial, probably no deeper than the Copper Ridge dolomite. The vertical attitude of the beds near the fault indicates that the thrust faults are more in the nature of upthrusts than overthrusts. Because the thrust, transmitted through the Copper Ridge dolomite beneath the synclines, has a horizontal direction, it yielded upward toward

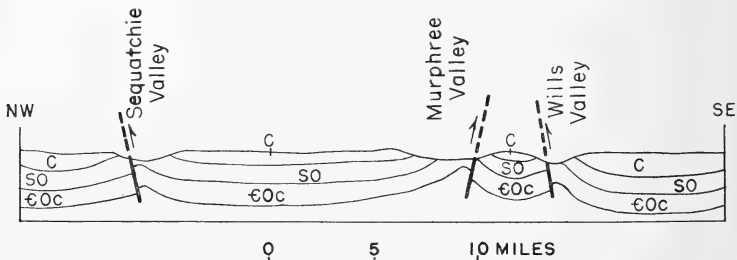

FIG. 3.—Generalized section across Sequatchie Valley, Murphree Valley, and Wills Valley anticlines, Alabama, showing the thrust-bearing bed (εOc) beneath the broad synclines.

the surface and the upbowing of the anticlines was practically vertical; slight variation in direction of pressure might determine which limb of the anticline would be steeper. The dip of the rocks on the southeast side of the Murphree Valley may have been steeper because the Copper Ridge dolomite beneath the syncline to the southeast may have been lower than that in the syncline to the northwest, and the thrust therefore may have been transmitted lower on that side, a condition which would have produced an underthrust effect in the anticline and have caused the rocks on the southeast side to be steeper (Fig. 2). Such a condition may have been augmented by the close proximity (4 miles) of the southwest plunging end of the Wills Valley anticline, which is unbroken by a thrust fault at this end, and the Copper Ridge dolomite may have descended deeper in the intervening syncline.

There is no evidence for the suggestion by J. L. Rich (1934, p. 1595) that the Sequatchie anticline may be similar to the Pine Mountain thrust. Rodgers (1950, p. 679) has shown that the Sequatchie anticline does not pass into tear faults at its northeast and southwest ends, as does the Pine Mountain thrust, but he supports Rich's analogy of these thrusts by suggesting (his fig. 3, p. 678) their connection by deep-lying faults beneath the intervening flat-lying Carboniferous basins. These connecting hypothetical faults are indeed "bizarre" (p. 680), and there is no evidence that such faults exist, particularly the connection with the Murphree Valley fault which has the overthrust from the north-

west, whereas the fault emanates from a thrust in the opposite direction—from the southeast. The structure at Post Oak Springs and Rhea Springs, Kingston quadrangle, may be either younger beds in a window, as is suggested by Rodgers, or they may be explained, as they were by Hayes (1894) with other similar occurrences in the area, as sharply folded and faulted beds of these younger strata. Therefore, they may possibly be windows in the Pine Mountain overthrust like those reported by Miller in Virginia (1947, 1950). These and other suggestions must be considered in the explanation of these structures, and their solution will depend on the results of future more detailed work.

## REFERENCES

- BUTTS, CHARLES. *Geology of Alabama*. Alabama Geol. Surv. Spec. Rep. 14. 1926.
- HAYES, C. W. *Kingston quadrangle, Tenn.* U. S. Geol. Surv. Geol. Atlas, Folio 4. 1894.
- . *Pikeville quadrangle, Tenn.* Ibid., Folio 21. 1895.
- . *Gadsden quadrangle, Ala.* Ibid., Folio 35. 1896.
- MILLER, R. L., and FULLER, J. O. *Rose Hill oil field, Lee County, Va.* U. S. Geol. Surv. Oil and Gas Invest., Map 26. 1947.
- and BROSGE, W. P. *Jonesville district, Lee County, Va.* Ibid., Map 104. 1950.
- RICH, J. L. *Mechanics of low-angle overthrust faulting as illustrated by Cumberland thrust block, Virginia, Kentucky, and Tennessee.* Bull. Amer. Assoc. Petr. Geol. 18(12): 1584-1596. 1934.
- RODGERS, JOHN. *Mechanics of Appalachian folding as illustrated by Sequatchie anticline, Tenn. and Ala.* Ibid. 34(4): 672-681. 1950.
- ULRICH, E. O. *Revision of the Paleozoic systems.* Bull. Geol. Soc. Amer. 22: 281-680. 1911.

PALEONTOLOGY.—*The arms of Haerteocrinus.* HARRELL L. STRIMPLE, Bartlesville, Okla. (Communicated by Alfred R. Loeblich, Jr.)

Over a period of several years the author has acquired three well-preserved specimens of the genus *Haerteocrinus* from the Wann formation exposure located just west of the city limits of Bartlesville, Okla. Description is given below.

***Haerteocrinus turbinatus*, n. sp.**

Figs. 1-7

The dorsal cup expands evenly from the proximal columnal to its upper extremity. Infrabasals

(IBB) are five upflared plates, readily visible in side view of the cup. Basals (BB) are five, with height and width approximately equal. Radials (RR) are five, pentagonal, with width normally almost twice the length. The uppermost portion of the cup has a scalloped appearance when viewed from above or below due to the impressions between RR along the adsutural areas. This development restricts the width of the articulating facets.

There are three plates in the posterior inter-

radius, which area is not depressed. Radial (RA) is obliquely placed, contacting r. post. R to the right below, the right shoulder of post. B to the left below, anal plate (X) to the left above, and right anal plate (RX) directly above. Anal X is in full contact with post. B. RX is the smaller of the three and its upper surface forms a common plane with X. The upper surfaces of both RX and X have muscular fossae somewhat comparable to those of the RR. There is an outer ligament pit bordered by a transverse ridge. The outer marginal ridge and transverse ridge possess denticles, and other crenulations are found behind the muscle scar. Intermuscular notches are narrow but well defined, that of anal X being to the left of center, and of RX to the right of center.

Articulating facets of RR slope mildly outward and do not fill the upper faces of RR. There is a small outer rim in front of the sharp outer ligamental furrow. The transverse ridge is pronounced and is marked with denticles. Lateral furrows are well defined and intermuscular notch is rather large. Muscle scars are shallow.

First primibrachials (PBrBr) in all rays are low, axillary plates, having triangular outlines. A second branching takes place with the fourth or fifth secundibrachials (SBrBr) in all rays. Thereafter, the outer rays remain unbranched and taper slowly to their termination. In the inner rays, the arms widen slowly as a third division is approached, with or about the sixth tertibrachials (TBrBr), and subsequently formed outer rays remain unbranched to their termination. There is another gradual widening of the inner rays as another bifurcation is approached, with or about the sixth quaterbrachials (QBrBr). The arms are not preserved to their termination in all rays; however, 40 robust, pinnular, elongated, uniserial arms are indicated. The brachials are all rather short and have well-rounded, smooth exteriors.

The column is composed of round, moderately thick segments, which are pierced by a small pentalobate lumen. In the large figured paratype, the proximal columnal is seen to have a mildly pentagonal outline.

The plates of the dorsal cup are rather thick, and their external surfaces have a natural sheen, as if the specimens were polished. At their distal extremities, the IBB have a thickness of 2.0 mm in the large paratype. Sutures are not impressed and there is no granular surface ornamentation.

Both paratypes provided information as to the nature of the tegmen. The smaller paratype discloses the fact that the arms are considerably longer than the tegmen, which only has a length of about 35.5 mm. The tube terminates with a swollen area composed of enlarged, spinose plates. Some plates possess more than one spine, and none of the spines are extended to any great degree. Some pore slits are found in plates of the swollen area. Remnants of the anal tube were found intimately associated with the larger paratype. Normal tube plates have an external sheen comparable to the "polished" appearance of the exterior of the crown. Terminating tube plates are mildly spinose, show evidence of pore slits, and are considerably larger than normal tube plates. It is puzzling to note that normal tube plates show no evidence of pore slits.

*Measurements in mm.*—As given below. All measurements are linear and are not taken along the curvature of the plates.

	Large figured paratype	Small figured paratype	Holotype
Height of dorsal cup .....	19.8	13.1*	14.0*
Width of dorsal cup (maximum).....	32.7	21.1*	21.9*
Diameter of proximal columnal.....	7.6	6.0	6.0
Height of IBB circlelet .....	6.3	3.8*	4.0*
Length of inter IBB suture .....	4.7	2.0	2.0
Length of r. ant. B.....	10.0	6.8	7.0
Width of r. ant. B.....	10.7	7.0	8.1
Length of inter BB suture.....	5.1	3.1	3.3
Length of r. ant. B.....	7.9	5.7	6.3
Width of r. ant. R.....	15.7	8.7	7.1*
Height of l. ant. PBr.....	6.2	4.0	5.0
Width of l. ant. PBr.....	13.7	7.8	9.6

\* Distorted owing to lateral compression.

*Remarks.*—There are at this time only three species assigned to *Haerteocrinus*. The genotype species is *Haerteocrinus missouriensis* Moore and Plummer, from the Missouriian. In that species the plates of the posterior interradius are more advanced in their arrangement than those of *H. turbinatus*, in that RA has moved to a dominant position in the former, separating anal X from the post. B. From the illustrations given by Moore and Plummer it does not appear that distal faces of anal X and RX form a common plane, as found in *H. turbinatus*; however, they are of subequal height and may well have done so.

*H. magnus* Moore and Plummer, of the Des Moines series, is based on a single partially preserved dorsal cup, so that close comparison is not possible. From the illustrations given by Moore and Plummer there appear to be slight depres-

sions at the angles of the cup plates, and anal X is in contact with an elongated post. B.

*H. washburni* (Beede) is most similar to the present species. The principal difference is in the

elongated nature of the basal plates and the wider, more robust RX. Although plates of the posterior interradius display considerable variability in some forms, all three specimens of *H.*

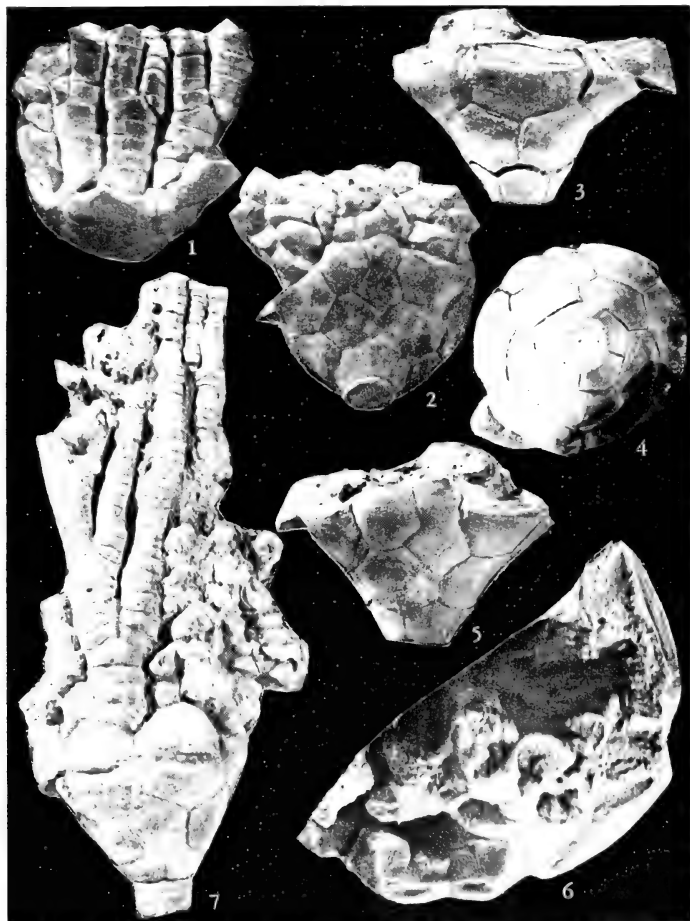

FIGS. 1-7.—*Haertereocrinus turbinatus*, n. sp.: 1-2, Holotype from anterior and posterior,  $\times 1.5$ ; 3-6, large paratype from anterior, base and posterior,  $\times 1.2$ , and portion from summit,  $\times 2.3$ ; 7, paratype from left side,  $\times 1.7$ .

*turbinatus* display remarkable consistency in this regard. In *H. turbinatus*, the RX is relatively smaller than found in *H. washburni*.

Close affinity between *H. turbinatus* and *Texacrinus irradiatus* Strimple is indicated in the nature of the arms and many features of the dorsal cups. In both species the anal X and RX form a common upper facet which is similar to the facets of the RR. The main difference lies in the nature of the IBB circlelets, which repose at

the bottom of a basal concavity in *T. irradiatus* but are upflared and readily visible in side view of the cup in *H. turbinatus*.

*Occurrence and horizon.*—The hill, locally termed "The Mound," just west of the city limits of Bartlesville, Okla.; crinoid facies of the Wann formation, Ochelata group, Missouri series, Pennsylvanian.

*Types.*—To be deposited in the U. S. National Museum.

PALEONTOLOGY.—*Designation of the type species of Pseudochama (additional note).* DAVID NICOL, U. S. National Museum.

In my recent paper on the genera and subgenera of Chamidae (Nicol, 1952), I stated that the type species of *Pseudochama*, *Chama cristella* Lamarck, was subsequently designated by Prashad (1932, p. 295). Mr. Druid Wilson, of Johns Hopkins University, has kindly shown me that the same species was designated as the type of *Pseudochama* by Gardner (1926, p. 92).

#### REFERENCES

- GARDNER, JULIA. *The molluscan fauna of the Alum Bluff group of Florida, Part II: Astartacea, Carditacea, Chamacea*. U. S. Geol. Surv. Prof. Paper 142-B; 81-99, pls. 16, 17. 1926.
- NICOL, D. *Nomenclatural review of genera and subgenera of Chamidae*. Journ. Washington Acad. Sci. 42 (5): 154-156. 1952.
- PRASHAD, B. *The Lamellibranchia of the Siboga Expedition, Systematic Part II: Pelecypoda (exclusive of the Pectinidae)*. Siboga Monograph 53c: 353 pp., 9 pls., 1 map. Leiden, 1932.

ENTOMOLOGY.—*The ant larvae of the myrmicine tribe Crematogastrini.*<sup>1</sup> GEORGE C. WHEELER and JEANETTE WHEELER, University of North Dakota. (Communicated by C. F. W. Muesebeck.)

The late Dr. W. M. Wheeler could often predict by merely looking at a stone or log what kinds of ants would be found under (or in) it. In the summer of 1924 when he and I were collecting on Barro Colorado Island, he selected a certain log as promising. But this time he had made a mistake, for as soon as we opened it he exclaimed, "Just another one of those nasty little Crematogasters!" I was startled—almost shocked—that one of the world's foremost myrmecologists should speak thus disrespectfully of any ant. It was practically blasphemy—myrmecoblasphemy, that is.

To be sure, it was merely an *obiter dictum*. Nevertheless it did seem to express Dr. Wheeler's general attitude toward this genus. In his introduction to the *Ants of*

*the Belgian Congo*<sup>2</sup> he said:

At my request, Dr. F. Santschi kindly undertook to work up the species of *Crematogaster*, a genus to which he has given much attention. A glance at my catalog of the Ethiopian species will show why I despaired of adequately handling the Congo material of the group. I might have attempted it, if the *Crematogaster* portion of Mr. George Arnold's monograph of the Rhodesian ants had appeared, but the World War had stopped the publication of this important work, so that even in making my catalog I had nothing to rely on except the confused mess in the existing literature. Mr. Arnold nevertheless sent me some valuable comments on several of the species, together with the following remarks on the genus as a whole: "The genus *Crematogaster* is perhaps the most troublesome of all, and for this there are several reasons. First of all, it is a very large genus, so large that authors get lost in the vast number of described forms and of their collections. Secondly, the species of this genus in Africa are exceptionally liable to minute variations in all

<sup>1</sup> The research on which this article is based was aided by a grant-in-aid from the Sigma Xi Research Fund.

<sup>2</sup> Bull. Amer. Mus. Nat. Hist. 45: 7-8. 1922.



directions even over a very small area. . . . and even within the limits of the same nest. . . . Thirdly, in the separation of species and varieties, too much emphasis has been placed on unreliable characters. . . . Lastly, a good deal of confusion is due to sheer carelessness and contempt for exact methods."

This same distaste for *Crematogaster* seems to be rather general among myrmecologists. I have certainly shared it when collecting in Oklahoma, Texas, and Central America, where it is one of the commonest genera.<sup>3</sup> And now the study of the larvae has strengthened my distaste.—G. C. WHEELER.

\* \* \*

Tribe CREMATOGASTRINI Forel

The tribe Crematogastrini comprises a single genus. But what a genus! Emery in his *Genera insectorum* listed 274 species, which make it the fourth largest genus of ants. These species are grouped in 11 subgenera; many of them have numerous subspecies and varieties. But all this is merely small-scale diversity. The genus as a whole—both adults and larvae—is remarkably homogeneous and easily recognized at a glance.

But as soon as one steps inside the genus, all is confusion. It is not possible to characterize larval subgenera (at least with the material at hand), for the differences within a subgenus may exceed those between subgenera. In fact, the differences within a single nest may surpass those between subgenera.

This brings us to the most remarkable discovery in this study: the apparent dimorphism of the larvae of *Crematogaster lineolata subopaca*, which is fully described below and illustrated on the plates. It is certainly tempting to speculate on the cause of this phenomenon—dimorphic queens, social parasitism, genetic segregation after hybridization, etc. But we resist temptation and simply state that we do not have enough facts even for a tentative hypothesis.

Genus *Crematogaster* Lund

Plump, chunky, and straight; practically immobile; subellipsoidal or subcylindrical; ends

<sup>3</sup> In North Dakota the picture is entirely different: *Crematogaster* is rare in the southern half of the State and apparently absent in the northern half.

rounded; anterior end formed by the dorsum of the prothorax; head flattened against the ventral surface near the anterior end; no neck. Anus posterior. Leg vestiges present. Segmentation indistinct. Spiracles unequal in diameter, the first (i.e., mesothoracic) much the largest, the remainder small and diminishing progressively toward the posterior end. Body hairs sparse; uncinuate hairs short to moderately long; other hairs minute to short. Seven types of body hairs occur in the genus: (1) simple; (2) with the tips bifid; (3) with the tips multifid; (4) with the tips frayed; (5) with the apical portion denticulate; (6) with the apical portion broad, flat and denticulate; (7) uncinuate hairs, with a heavy, nearly straight shaft and a stout anchor-like tip, restricted to the dorsal surface of abdominal somites I-V or I-VI and arranged in transverse rows of 3-8 hairs, one row on each somite. A species may have two, three or four of these types; the majority have three types. Head with the dorsal and dorsolateral regions thin and depressed; mouth parts small; from each gena a sclerotized band (which is a continuation of the internal skeleton) passes out of the head and enters the prothorax. Antennae small or minute; each with 1-4 (usually 2 or 3) sensilla. Head hairs sparse; minute to short; usually shorter than body hairs; mostly simple. Labrum very small and short; breadth 3-4X length; subtrapezoidal or subrectangular; ventral border concave; anterior surface with 1-4 isolated and two agglomerated sensilla on each half; posterior surface with 4-8 sensilla, but without spinules. Mandibles very small [ratio of head width to mandible length = 4.3 to 9.4 (average 6.7)]; short [ratio of mandible length to width at base = 1.3 to 2 (average 1.5)]; base inflated and feebly sclerotized; apex moderately sclerotized, narrowed to a sharp point and slightly curved medially; no medial teeth; no spinules. Maxillae small; apex paraboloidal and directed medially; without spinules; palp represented by a cluster of three or four agglomerated sensilla; galea represented by two agglomerated sensilla. Labium small; without spinules; palp represented by a cluster of four agglomerated sensilla; a minute sensillum between each palp and the opening of the sericteries; the latter a short transverse slit. Palps and galea never paxilliform. No spinules seen on the hypopharynx.

To most of the characters in the foregoing definition there are exceptions. Nevertheless the

larvae of *Crematogaster*—like their adults—constitute a well defined and homogeneous group. They are readily distinguished from the larvae of other tribes by the shape of the body; the position of the head; the variation in the size of the spiracles of different somites; the paucity and small size of the hairs (except the few uncinat hairs); the depressed dorsal and dorsolateral regions of the head; the sclerotized band emerging from each gena; the reduction of the mouthparts; the reduction of the palps and galea to clusters of sensilla; the lack of spinules on the mouth parts. None of these characters would alone serve to differentiate the larvae from those of all other genera, but as a group they define the genus and tribe very well.

The larvae of *Crematogaster* closely resemble the larvae of the subfamily Dolichoderinae in all the above characters, but they may be differentiated as follows: In the latter the first abdominal spiracle is the largest; uncinat hairs lacking (or, when present, with only one hook); dorsal and dorsolateral regions of the head not depressed (except in *Dolichoderus*); no sclerotized band emerging from each gena; spinules present on the mouth parts. The dolichoderine *Azteca* is the genus most easily confused with *Crematogaster*; in fact, it can be distinguished only by the presence of spinules on its mouth parts and by the shape of its uncinat hairs, which are spirally coiled and have only one hook.

Also like the Dolichoderinae, the larvae of the Crematogastrini are a highly specialized group and both groups are specialized mostly through reductions and losses rather than by elaborations: body length is reduced; mobility is almost lost; hairs are few, short and simple (except the few uncinat hairs); mouth parts are reduced—almost vestigial; the trophorhinium is lacking; palps and galea are merely clusters of sensilla.

In this article we describe the larvae of 11 species representing four subgenera. References from the literature are cited for additional species, making the total considered 16 species in five subgenera.

Athias-Henriot (1947, p. 253) characterized the larvae of this genus as "évolués, simples, . . . reliant [les Myrmiciniés] aux [Dolichodérinés]."

Bristowe, 1932: "The nests of a species of *Crematogaster* (called Mott dam) are collected on account of their grubs which are eaten in a curry in the Hua Hin district."

Gantes, 1949: "Larves immobiles" (p. 84). "La croissance est forte au stade IV et elle est ralentie au stade V, mais ce ralentissement est très faible" (p. 85). "Chez *Crematogaster* les poils à double crochet sont plus longs au stade IV qu'au stade V. Donc, l'accrochage mutuel, important pour le transport des larves par les  $\sigma$ , est surtout possible aux stades jeunes, II à IV" (p. 87). "Larves très évoluées comme *Crematogaster* . . . Ces larves sont immobiles, ont des mandibules minuscules" (p. 88).

Stärcke, 1948, p. 28: "Body still more swollen, of a short oval or nearly globose shape, with a small head projecting on the ventral side."

#### *Crematogaster* (*Acrocoelia*) *lineolata* Say

Fig. 1 (1-4)

Plump, chunky, and turgid; straight and sub-ellipsoidal; diameter greatest at abdominal somite II; ends round-pointed; anterior end formed from the dorsal portion of the prothorax. Head flattened against the ventral surface near the anterior end; no neck. Anus posteroventral. Leg, wing, and gonopod vestiges present. Approximately a third of the larvae have one, two, or three abdominal leg vestiges (?) on somites I-III, which are larger and more conspicuous than those on the thorax. Segmentation indistinct. Spiracles unequal in size; the first much the largest, the remainder diminishing gradually. Integument of the posterior somites with a few spinules which are either isolated or in short transverse rows. In addition, approximately half the larvae have on each lateral surface of most somites a dorsoventrally elongate patch of minute, stout spinules. Body hairs sparse, somewhat more abundant on the prothorax. Of two types: (1) simple, slightly curved, 0.009-0.036 mm, the most numerous type; (2) a row of four to six nearly straight 2-hooked uncinat hairs on the dorsal surface of each abdominal somite I-VI, about 0.14 mm long. Head moderately large; subtrapezoidal or subcordate in anterior view; narrowed ventrally; about as long as broad; extensive dorsolateral portions thin and depressed; mouth parts small. Inside the head just above the level of the mouth parts there is a slender transverse sclerotic bar; at each end of this bar a large sclerotized lobe is exposed on the surface and extends outward into the prothorax; a slender branch of the lobe extends upward inside the gena and at its end protrudes laterally for a short distance. Antennae

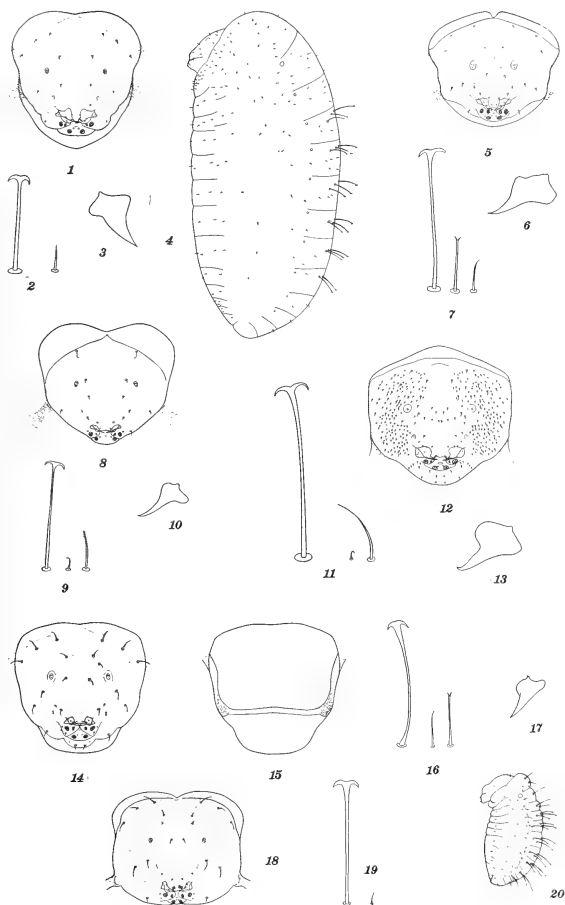

FIG. 1.—*Crematogaster (Acrocoelia) lineolata* Say: 1, Head in anterior view,  $\times 76$ ; 2, two body hairs,  $\times 185$ ; 3, right mandible in anterior view,  $\times 216$ ; 4, larva in side view,  $\times 32$ . 5–7, *C. (A.) laeviuscula* Mayr: 5, Head in anterior view,  $\times 60$ ; 6, left mandible in anterior view,  $\times 216$ ; 7, three body hairs,  $\times 185$ . 8–10, *C. (A.) menileki proserpina* Santschi: 8, Head in anterior view,  $\times 86$ ; 9, three body hairs,  $\times 185$ ; 10, left mandible in anterior view,  $\times 216$ . 11–13, *C. (A.) auberti sordida* Forel: 11, Three body hairs,  $\times 185$ ; 12, head in anterior view,  $\times 76$ ; 13, left mandible in anterior view,  $\times 216$ . 14–20, *C. (A.) lineolata subopaca* Emery: 14, Head of type A in anterior view,  $\times 76$ ; 15, head of type B in anterior view to show chitinized bar,  $\times 76$ ; 16, three body hairs of type A,  $\times 185$ ; 17, left mandible of type A in anterior view,  $\times 216$ ; 18, head of type B in anterior view,  $\times 76$ ; 19, two body hairs of type B,  $\times 185$ ; 20, very young larva in side view,  $\times 32$ .

minute, each with three (rarely two or one) sensilla. Head hairs sparse, very short (0.009–0.035 mm), simple and slightly curved. Labrum very small; short (length one-third the width); subtrapezoidal in anterior view; narrowed ventrally; ventral border feebly to moderately concave; anterior surface of each half with two or three isolated sensilla and two agglomerated sensilla near the ventral border; posterior surface with four scattered sensilla. Mandibles very small; apical two-thirds rather stout, sharp-pointed, slightly curved medially, moderately sclerotized; basal one-third feebly sclerotized and inflated. Maxillae small; apex paraboloidal and directed medially; palp a cluster of four sensilla; galea two agglomerated sensilla. Labium small; palp a cluster of four sensilla; a minute sensillum between each palp and opening of sericteries; the latter a short transverse slit.

QUEEN: Similar to worker, except that the body is relatively more voluminous and the head and hairs relatively smaller.

(Material studied: Numerous larvae from six nests collected in Michigan, New Hampshire, New Jersey, and New York.)

***Crematogaster (Acrocoelia) lineolata*  
subopaca Emery**

Figs. 1 (14–20), 2

WORKER TYPE A: Plump, chunky, and turgid; straight and subcylindrical, with the dorsal and ventral profiles nearly straight and moderately long, while in ventral view there is a slight constriction at abdominal somites I and II; ends round-pointed, the posterior end more narrowly so; anterior end formed from the dorsal portion of the prothorax. Head thin and flattened against the ventral surface near the anterior end; no neck. Anus posteroventral. Leg, wing and gonopod vestiges present; abdominal leg vestiges (?) very rarely present. Segmentation indistinct. Spiracles unequal in size, the first much the largest, the remainder diminishing gradually. Integument of abdominal somites VI–X spinulose, the spinules minute and isolated or in short transverse rows. Body hairs sparse, somewhat more abundant on the prothorax. Of three types: (1) simple, very short (about 0.027 mm on the ventral surface to 0.045 mm on the dorsal surface), the most abundant type; (2) with the tip bifid, about 0.045 mm long, a few on the dorsal surface of each

somite; (3) nearly straight 2-hooked uncinat hairs, moderately long (about 0.14 mm), six to eight in a row across the dorsal surface of each abdominal somite I–VI. Head subtrapezoidal in anterior view; narrowed below; slightly broader than long; dorsolateral regions thin and depressed; mouth parts small. Inside the head, just above the level of the mouth parts, there is a slender transverse sclerotic bar; each end of the bar turns upward and continues inside the gena; it finally becomes external near the dorsal corner of the cranium and extends laterally a short distance onto the prothorax. Antennae minute, each with three (rarely two) minute sensilla. Head hairs sparse, short (0.009–0.035 mm), simple and slightly curved. Labrum very small, short (length one-fourth the width), subtrapezoidal, narrowed ventrally; ventral border feebly concave; anterior surface of each half with four isolated sensilla and with two agglomerated sensilla near the ventral border; posterior surface with three sensilla on each half. Mandibles very small; apical two-thirds slender, sharp-pointed, slightly curved medially, moderately sclerotized; basal third feebly sclerotized and widely inflated. Maxillae small; apex paraboloidal and directed medially; palp represented by a cluster of four sensilla; galea represented by a cluster of two agglomerated sensilla. Labium small; palp represented by a cluster of four sensilla; a minute sensillum between each palp and opening of sericteries; the latter a short transverse slit between the tips of the maxillae.

WORKER TYPE B: Plump and chunky; straight and subcylindrical; not constricted at the middle; ends round-pointed; anterior end formed from the dorsal portion of the prothorax. Head thin and flattened against the ventral surface near the anterior end; no neck. Anus posteroventral. Leg and wing vestiges present. Abdominal leg vestiges (?) on somites I–III are much larger and more conspicuous than those on the thorax; in alcoholic material they are brown and can be readily seen at a low magnification; typically three pairs are present but the number may vary from zero to six vestiges. Ten differentiated somites. Spiracles unequal in size, the first much the largest, the remainder diminishing gradually. The thoracic somites and the first seven or eight abdominal somites bear each a pair of conspicuous lateral welts; each welt is elongate dorsoventrally and narrow antero-posteriorly; it stains deeply with acid fuchsin and

its surface is rugose.<sup>4</sup> On either side, between these welts and near their ventral ends, there are integumentary structure of unknown nature

<sup>4</sup>These welts should be compared with the lateral projections described by Eidmann and Menozzi. See our Figs. 3 and 4.

and function. Integument of posterior somites spinulose, the spinules minute and isolated. Body hairs sparse. Of two types; (1) simple, minute (0.003-0.018 mm) fairly uniformly distributed; (2) nearly straight two-hooked uncinate hairs, moderately long (about 0.1 mm),

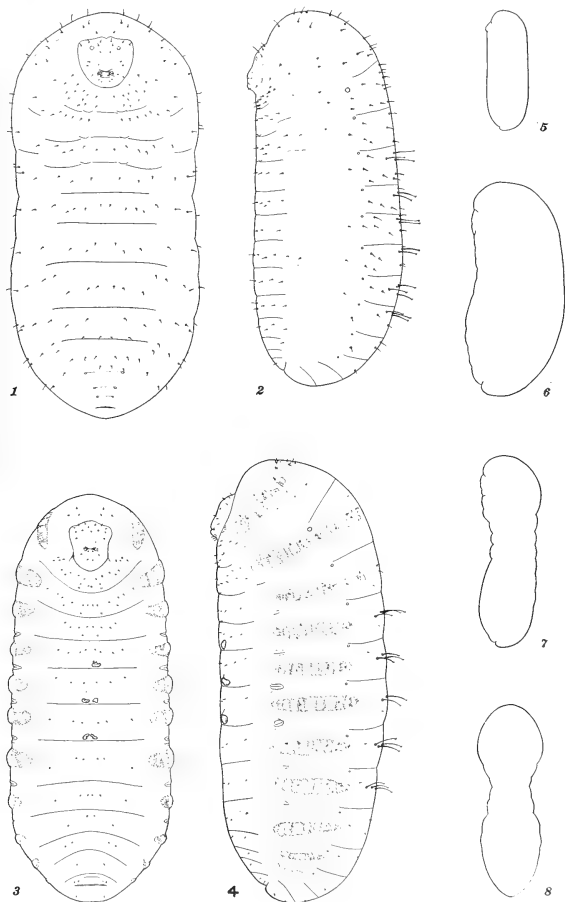

FIG. 2.—*Crematogaster (Acrocoelia) lineolata subopaca* Emery: 1, Larva of type A in ventral view,  $\times 32$ ; 2, larva of type A in side view,  $\times 32$ ; 3, larva of type B in ventral view,  $\times 32$ ; 4, larva of type B in side view,  $\times 32$ ; 5, profile of queen larva,  $\times 8$ ; 6, profile of worker larva,  $\times 8$ ; 7, profile of male larva,  $\times 8$ ; 8, outline of male larva in ventral view,  $\times 8$ .

three to six in a row across the dorsal surface of each abdominal somite I-V. Head subrectangular in anterior view, slightly broader than long; small dorsolateral areas depressed and thin; integument sclerotized; mouth parts small. At the ventrolateral corner of the head on each side a sclerotized lobose structure emerges and enters the prothorax, where it extends for a short distance; from this a narrow sclerotized bar extends dorsally inside the gena. Antennae minute, with three sensilla each. Head hairs sparse, short (about 0.027 mm), simple and slightly curved; four minute (about 0.003 mm) hairs on the clypeus. Labrum very small, short (length  $\frac{1}{2}$  x the width), subrectangular, ventral border feebly concave; anterior surface of each half with four isolated and two agglomerated sensilla; posterior surface with four minute sensilla. Mandibles very small; apical two-thirds slender, sharp-pointed, slightly curved medially and moderately sclerotized; basal one-third feebly sclerotized and widely inflated. Maxillae small; the apex paraboloidal and directed medially; palp represented by four agglomerated sensilla; galea represented by two agglomerated sensilla. Labium small; palp an agglomerated cluster of four sensilla; a minute sensillum between each palp and opening of sericteries; the latter a short transverse slit.

**YOUNG:** Length 0.75-0.95 mm. Plump and chunky; with broad lateral longitudinal warts; dorsal profile C-shaped; ventral profile sinuate; about five somites distinct; the prothorax shows two ventrolateral bosses and a transverse ventral welt. Head on the anterior end. Anus ventral. Body hairs similar to the mature type A larva, but a little shorter. On some young larvae (about 0.95 mm long) there are one to six abdominal leg vestiges (?); presumably these would belong to Type B.

**QUEEN:** Of two types, A and B; each type is similar to worker type A or B respectively, except that the body is much more voluminous and the head and hairs relatively smaller.

**MALE:** More elongate; thorax swollen; abdominal somites I-II constricted; rest of abdomen swollen; ends rounded, the posterior more narrowly so; anterior end formed from the dorsal portion of the prothorax. Anus subterminal. Leg and wing vestiges present. The only distinct somites are abdominal I-III, otherwise similar to type A worker larva.

(Material studied: Numerous larvae from five nests collected in Arkansas and Texas.)

***Crematogaster (Acrocoelia) aegyptica senegalensis* Roger**

Gantes, 1949: "♀ 3 mm. Ce sont des larves évoluées, le corps est massif, la tête forme un mamelon à la partie antérieure; les segments sont séparés par de simples lignes blanches: 11 segments. Le corps est couvert de plusieurs sortes de poils, mais on remarque immédiatement sur le dos, des poils à double crochet de 0 mm. 11 de long; ils sont dressés raides sur le dos, on a cinq rangs de six poils, uniquement sur les segments abdominaux. Sur tout le corps on a des poils défensifs de 0 mm. 18 de long. Près de l'anus un poil assez long, fourchu, de 0 mm. 05 et un minuscule à trois branches de 0 mm. 009. La tête est large, couverte de poils simples. Les mandibules sont très petites, 0 mm. 032, fines et aiguës, elles s'insèrent dans la tête par deux branches courtes: elles ressemblent à une lame de couteau. Le palpe proximal et le palpe labial n'ont que quatre sensilles" (p. 83). Pl. V, Fig. IX—larva in side view; hairs enlarged. Growth data are given on page 86.

***Crematogaster (Acrocoelia) auberti laestrygon* Emery**

Athias-Henriot, 1947: "Sa tête mal différenciée (un simple mamelon buccal), son corps presque cylindrique, ses six segments abdominaux. Le corps est recouvert d'une fine pubescence et les segments abdominaux portent dorsalement deux énormes macrochètes fourchus et crochus" (p. 252). Internal anatomy is discussed on pages 260 and 263.

Eidmann (1926, p. 726) referred to the absence of lateral papillae and the presence of uncinata hairs in var. *submaura*. (Mentioned by Eidmann, 1927.)

Gantes, 1949: "Ressemble beaucoup à [*senegalensis*], mais elle a des poils plus variés, les mandibules sont plus longues, 0 mm. 41 et plus fines. Les poils à double crochet en six rangs de quatre à partir du métathorax sont plus longs, 0 mm. 21 et se dressent rigides sans ressort. Vers le bout de l'abdomen ils sont un peu plus courts, 0 mm. 198. De plus sur le thorax nous trouvons des poils identiques, mais plus courts, 0 mm. 115. Sur tout le reste du corps on trouve des poils fourchus de 0 mm. 05 et des poils

simples de 0 mm. 04" (p. 83). Pl. V, Fig. IX P9, five hairs.

**Crematogaster (Acrocoelia) auberti  
sordida** Forel

Fig. 1 (11-13)

Subcylindrical and relatively slender. Body hairs numerous. Of three types: (1) minute (0.009 mm), simple, with apical half fine and flexible, on the ventral surface; intergrading on the lateral surfaces to (2) longer (0.09 mm), simple and slightly curved, on the dorsal surface; (3) a row of 4-6 nearly straight, moderately long (0.18 mm), 2-hooked uncinata hairs across the dorsal surface of each abdominal somite I-VI. Head hairs minute and exceedingly numerous (about 300). Head subhexagonal in anterior view; dorsal region thin and depressed. Antennae moderately large. Other characters apparently similar to *laeviuscula*. (Material studied: About 50 damaged integuments from Tunis.)

**Crematogaster (Acrocoelia) impressa** Emery

Eidmann, 1941: "Die Larven zeigen in ihrem Habitus mancherlei Besonderheiten und weichen in dieser Hinsicht von dem üblichen Aussehen der Ameisenlarven nicht unwesentlich ab. Sie sind walzenförmig und gerade gestreckt, also nicht, wie zumeist, ventral eingekrümmt. Das Vorderende ist dadurch ausgezeichnet, dass der Kopf von dem stark entwickelten Prothorax kapuzenförmig überragt wird. Der hintere Teil der Kopfkapsel ist weit in den Prothorax zurückgezogen, so dass die Mundteile senkrecht nach unten, d.h. nach der Ventralseite herausragen. Bei den jüngeren Larven ist die Vorwölbung des Prothorax weniger ausgesprochen als bei den Altlarven. Sämtliche Larven tragen auf der Dorsalseite der ersten sechs Abdominalsegmente grosse ankerförmige Hafthaare, die in je einer Querreihe angeordnet sind. Jede dieser Querreihen besteht aus 4-7, im Durchschnitt 6 Haaren, deren Zahl von vorn nach hinten abnimmt. Bei dem letzten Segment sind meist nur 2-4 vorhanden, bei den jüngeren Larven weniger als bei den älteren... Sie dienen dazu, das Aneinanderhaften der Larven zu Paketen zu ermöglichen, wodurch besonders bei Junglarven der Transport durch die Arbeiter erleichtert wird, können aber, wie vermutlich im vorliegenden Fall, auch zum Anhängen der Larven an den rauen Wandungen der Nestkammern dienen

und dadurch zu einer festen Lagerung und gleichmässigen Verteilung im Nest beitragen" (p. 214). Fig. 4 on p. 214 shows a young larva in side view, a mature larva in side view and an uncinata hair enlarged.

Eidmann, 1944, p. 446: "Die Larven sind durch ihre walzenförmige, gestreckte Gestalt und den Besitz von reihenartig angeordneten, ankerförmigen Oncochaeten auf der Dorsalseite der Abdominalsegmente ausgezeichnet."

**Crematogaster (Acrocoelia) laeviuscula** Mayr

Fig. 1 (5-7)

Plump, chunky, and turgid; straight and subellipsoidal; ends narrowly rounded; diameter greatest at abdominal somite II. Head thin and flattened against the ventral surface near the anterior end; no neck. Anus posteroventral. Leg, wing, and gonopod vestiges present. No abdominal leg vestiges found. Segmentation indistinct. Spiracles unequal in size; the first much the largest, the remainder diminishing gradually. Integument of the last few somites spinulose, the spinules minute and isolated or in short transverse rows of two or three. Body hairs sparse, somewhat more abundant on the prothorax. Of three types: (1) simple, slender, slightly curved, 0.01-0.07 mm long, the most numerous type; (2) bifid, about 0.054 mm long, two to six on each of the thoracic somites and on abdominal somites I-VI; (3) nearly straight 2-hooked uncinata hairs, 0.12-0.18 mm long, five or six in a row on the dorsal surface of each abdominal somite I-VI. Head moderately large; subtrapezoidal in anterior view; dorsal outline frequently with a median notch; narrowed below; about as long as broad; extensive dorsolateral regions thin and depressed; mouth parts small. Inside the head just above the level of the mouth parts is a very slender sclerotized transverse bar; at either end it joins a sclerotized lobe, becomes external and extends out for a short distance into the prothorax; a slender branch from this lobe extends dorsally inside the gena and becomes external near the dorsal corner of the cranium. Antennae small, each mounted on a low convexity and bearing three (rarely two) sensilla. Head hairs sparse, short (0.01-0.35 mm), simple and slightly curved. Labrum very small, short (length a little less than one-fourth the width); subtrapezoidal, narrowed ventrally; ventral border feebly to deeply impressed;

anterior surface of each half with three isolated and two agglomerated sensilla; posterior surface with two or three sensilla on each half. Mandibles very small; apical third slender, sharp-pointed, slightly curved medially, moderately sclerotized; basal two-thirds widely inflated and feebly sclerotized. Maxillae small; apex paraboloidal and directed medially; palp a cluster of four sensilla; galea two agglomerated sensilla. Labium small; palp a cluster of four sensilla; a minute sensillum between each palp and opening of sericteries; the latter a short transverse slit. (Material studied: Numerous larvae from two nests collected in Texas).

**Creumatogaster (Acrocoelia) menileki**  
**proserpina Santschi**

Fig. 1 (8-10)

Body hairs sparse, of three types: (1) Simple, minute (about 0.012 mm), with recurved tip; (2) with frayed tip, about 0.036 mm long, on the dorsal surface only; (3) nearly straight two-hooked uncinatate hairs, about 0.11 mm long, about four in a row on the dorsal surface of each abdominal somite I-V. Head hairs minute to very short (0.006-0.018 mm), with the tip recurved. Posterior surface of labrum with two isolated sensilla on each half. Mandibles with the apical two-thirds slender, sharp-pointed, slightly curved medially and moderately sclerotized; basal one-third inflated and feebly sclerotized. In other respects apparently similar to *lineolata*. (Material studied: A single damaged integument from the Belgian Congo.)

**Creumatogaster (Acrocoelia) rivai**  
**luctuosa Menozzi**

Fig. 3

Menozzi, 1930: "La larva del primo stadio, o da pochi giorni uscita dall'uovo, ha corpo ovale, poco allungato, molto più assottigliato all'innanzi che all'indietro, col lato dorsale, visto di fianco, convesso e quello ventrale in parte, anteriormente concavo e poi convesso posteriormente. Ha distinti, oltre il capo, 10 segmenti, l'ultimo dei quali piuttosto ristretto all'indietro e terminato con una sorta di lobo più o meno sviluppato. Tutti i segmenti hanno qualche peluzzo di forma semplice, inoltre i segmenti 4-10 sono provvisti al dorso, sulla linea mediana trasversale, di 3 o 4 lunghe setole terminate a doppio uncino. Il capo visto di lato ha la forma di un cono tronco, è fornito di mandibole piccole, strette ed appun-

tite. Lunghezza mm. 1,7; larghezza massima mm. 0,9. La larva del secondo stadio ha il corpo all'incirca rotondeggiante, fortemente depresso, quasi lenticolare, piano al dorso, mediocrementemente convesso al ventre, diviso in 12 segmenti oltre il capo. Questo è più largo che lungo, coi lati lobiformi. I segmenti 1-8 dell'addome sono provvisti lateralmente e in continuazione del piano dorsale di lunghe appendici più o meno rettangolari coll'apice ottusamente arrotondato; il 9° segmento (ultimo) è tribolato, cioè ha due appendici laterali alquanto più piccole di quelle dei segmenti precedenti e di forma subtriangolare e termina posteriormente, nella linea mediana, con un lobo codale a forma di cappuccio; inoltre i segmenti addominali 3-7 hanno in più ognuno, al ventre, nella linea mediana longitudinale, un'altra appendice di forma all'incirca eguale a quella dei lati, ma più corta. La funzione di tali appendici, che trovano riscontro in altre conformazioni omologhe ed analoghe di altre larve di formiche, si ritiene che sia quella di facilitare l'uscita per osmosi dei prodotti di escrezione emmessi da parecchie cellule del tessuto adiposo: infatti, ad un esame istologico, si trova che la parte distale delle dette appendici è riempita di un essudato sotto forma di liquido più o meno nettamente granuloso, mentre nella parte prossimale vi è un ammasso di numero variabile di cellule adipose o trofociti, di cui alcune, sparse pel corpo, ma quasi sempre raccolte in vicinanza

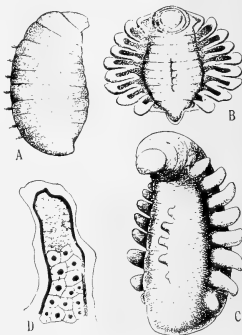

FIG. 3.—*Creumatogaster (Acrocoelia) rivai luctuosa* Menozzi: A, B, and C, Larvae of the first, second, and third stadia; D, longitudinal section of a lateral projection of a larva of the second stadium. (After Menozzi, 1930.)



dell'entrata dell'appendice, contengono numerosi cristalli di urato. La chetotassi delle larve in questo stadio è su per giù eguale a quella della larva precedentemente descritta e così dicasi anche per le setole uncinatate che si trovano sul dorso dei segmenti 4-10. Lunghezza mm. 1,02; larghezza mm. 1,48. Larva matura.—In questo stadio fatte le debite proporzioni, il corpo della larva riprende la forma somigliante alquanto a quella del primo stadio, cioè ovale ma più allungata e ancora più fortemente ristretta in avanti. Sono distinti, oltre il capo, 12 segmenti; il 2° segmento toracico é come i precedenti coi lati arrotondati, i segmenti successivi, eccetto l'ultimo, hanno le appendici che si trovano nella larva del secondo stadio, solo che esse sono ridotte in lunghezza. Lunghezza mm. 2,5; larghezza massima, presa sul 10° segmento e comprese anche le appendici laterali, mm. 1,6." (pp. 100-102). Fig. 3 on p. 101: A, B & C—larvae in the 1st, 2nd and 3rd stadia; D—longitudinal section of a lateral appendage of a second-stadium larva.

*Crematogaster (Acrocoelia) scutellaris* Olivier

Fig. 4

Berlese, 1902, p. 239: "Il primo grande stigma, perfettamente circolare è sul secondo segmento e tutti gli altri, che sono egualmente circolari, vanno decrescendo in diametro e sono scolpiti ciascuno su ciascuno dei segmenti successivi, cosicchè il primo e l'ultimo segmento del corpo non recano stigmi."

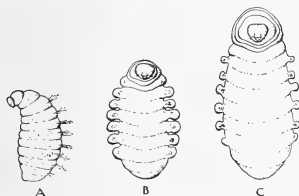

FIG. 4.—*Crematogaster (Acrocoelia) scutellaris* Olivier: A, Young larva in side view; B and C, older larvae in ventral view. (After Eidmann, 1926.)

Eidmann, 1926: "Wie kommt es, dass die Larven nicht durch ihre Schwere nach unten fallen und sich im unteren Teil der Kammern anhäufen? Sie besitzen, um dies zu verhindern, sehr zweckmässige Anpassungen. Auf der Dorsal-seite der mittleren Segmente findet man je eine

Querreihe von eigenartigen starken Haaren, während der übrige Larvenkörper nackt ist. Bei starker Vergrösserung sieht man, dass diese Haare an ihrer Spitze höchst merkwürdige Bildungen tragen. Die meisten enden in zwei Klauen, die entweder in einer Ebene liegen und dadurch wie ein Anker aussehen, oder auch nach einer Seite gerichtet sind. Die Haare der mittleren Segmente sind fast alle so gestaltet. Auf den hinteren Segmenten trifft man dagegen ganz seltsam geformte Endigungen der hier meist kürzeren Haare. Zackige, geweihartige und kronenförmige Gebilde sieht man hier in allen möglichen Variationen vertreten, von denen die Abbildung eine Auswahl zeigt, und zwischen ihnen stehen hier und da kurze, starre, borstenförmige Haare. Wie ein Wald von Hellebarden und Enterhaken starren einem diese Gebilde unter dem Mikroskop von dem Rücken einer Larve entgegen. Diese Haare stellen eine ausgezeichnete Haftvorrichtung dar, sowohl zum Anhängen der Larven an die Wände der steilen Kammern als auch zum Zusammenhängen mehrerer Larven zu Bündeln. Selbst an totem Alkoholmaterial kann man die Wirkung noch beobachten, Watteföckchen oder andere Fremdkörper haften ausserordentlich fest an ihnen und die zusammenhängenden Larven lassen sich nur schwer voneinander trennen. Sämtliche Larvenstadien sind mit diesen Hafthaaren versehen, die älteren Larven tragen jedoch neben diesen Haaren noch höchst merkwürdige Bildungen an ihrem Körper, die den jüngsten Stadien fehlen, und die ihnen ein ganz eigenartiges und ungewohntes Aussehen verleihen. Dies sind zwei Reihen von grossen, knopfartigen Papillen, die auf jeder Körperseite in einer Reihe hintereinander in der Zahl von sechs bis acht sitzen. Jedes Segment mit Ausnahme der ersten und letzten trägt links und rechts je eine solche Ausstülpung. Es scheint als ob die Papillen dem Wachstum ihrer Träger nicht folgen, denn bei älteren Larven sind sie relativ viel kleiner als bei den jüngeren Stadien. Der Zweck der Papillen lässt sich nicht ohne weiteres erkennen, doch nehme ich an, dass auch sie in irgendeiner Beziehung zu der Lebensweise in den hohen Nestkammern stehen. Bei *Cr. submaura*, die in der Erde lebt, fehlen nämlich diese Bildungen und ihre Larven sehen wie jede andere Ameisenlarve aus. Sie haben zwar auch die langen, ankerförmigen Hafthaare, doch ist dies keine Besonderheit, da eine Reihe anderer Ameisenar-

ten (*Pheidole*, *Solenopsis* u. a.) gleichfalls damit versehen ist. Die Papillenreihen der *Scutellaris*-Larven dienen wahrscheinlich auch dazu, das Festhängen und Haften an der Wand der Kammern und untereinander zu gewährleisten, vielleicht enthalten sie auch Drüsen, die ein klebriges Sekret absondern, wie die Rückpapillen der Larven von *Ponera coarctata*, wengleich sich diese weder in ihrer Grösse noch in ihrer Anordnung mit den Papillen der *Scutellaris*-Larven vergleichen lassen. Schliesslich wäre noch an eine dritte Möglichkeit zu denken, nämlich, dass es sich um Exsudatorgane handelt, wie sie Wheeler (1923) von verschiedenen Arten beschrieben hat, doch kann darüber wie über die vorhergenannten Möglichkeiten nur die genaue Beobachtung am lebenden Objekt Aufschluss geben" (pp. 724-726). (Mentioned by Eidmann, 1927; 1928, p. 237; 1936, p. 36.) Fig. 10 on p. 725, hairs; fig. 11 on p. 726, a young larva in side view, and two older larvae in ventral view.

**Crematogaster (*Crematogaster*) *acuta* (Fabricius)**

Fig. 5 (1-5)

Body straight, elongate-subellipsoidal, and rather slender; both ends rounded, but with the terminal somites directed posteroventrally and forming a low, blunt point; belly paunchy at abdominal somites III and IV. Head applied to the ventral surface near the anterior end; no neck. Anus ventral. Leg, wing and gonopod vestiges present. Segmentation indistinct. Spiracles unequal in size; the first much the largest, the remainder diminishing gradually. Integument of the dorsal surface of the posterior somites spinulose, the spinules isolated and minute. Body hairs moderately abundant, short to moderately long and rather uniformly distributed. Of three types: (1) Simple, short (0.02-0.08 mm), longest on the prothorax, slightly curved, limited to the ventral and ventrolateral surfaces; (2) curved, with multifid tip, 0.054-0.19 mm long, limited to the dorsal and dorsolateral surfaces, the tips directed dorsally or posteriorly, those on the prothorax the longest and most strongly curved; (3) nearly straight two-hooked uncinat hairs, about 0.19 mm long, usually four on each abdominal somite I-VI. Head very small, subhexagonal in anterior view; a fourth broader than long; somewhat narrowed dorsally, ventral outline convex; integument sclerotized; from each ventrolateral corner a heavily sclerotized

structure passes into the prothorax; mouth parts small. Antennae minute raised areas, each with three sensilla. Head hairs sparse, simple, slightly curved, moderately long (0.009-0.054 mm), with stout base and flexible tip. Labrum very small, short (length one-fourth the width), subtrapezoidal, narrowed ventrally: ventral border feebly concave; anterior surface with three isolated and two agglomerated sensilla on each half; posterior surface with three isolated sensilla on each half; ventral border with a few spinules. Mandibles very small; apical three-fifths moderately sclerotized, slender, slightly curved medially and tapering to a sharp point; basal two-fifths feebly sclerotized and only slightly inflated. Maxillae small; apex paraboloidal and directed medially; palp represented by three agglomerated sensilla; galea represented by two agglomerated sensilla. Labium small; palp represented by three agglomerated sensilla; a minute sensillum between each palp and opening of sericteries; the latter a short transverse slit. (Material studied: Numerous larvae from Panama Canal Zone.)

YOUNG: Length about 1.4 mm. Similar to the adult except as follows: Posterior end of abdomen somewhat attenuated and turned ventrally at right angles; ventral profile otherwise straight. Anus subterminal. Body hairs relatively longer and seemingly more abundant. Head relatively larger.

G. C. and E. H. Wheeler have recorded (1924, p. 54) 26 larvae of this species which were parasitized by an undetermined eulophid. Fig. 2 on page 55 is a photograph of two eulophid pupae inside one of the ant larvae.

***Crematogaster* (*Orthocrema*) *limata*  
*dextella* Santschi**

Fig. 5 (9-14)

Straight, subcylindrical, and rather stout; ends rounded; head and prothorax slightly bent ventrally; head anteroventral; no neck. Anus posteroventral. Leg, wing, and gonopod vestiges present. Segmentation indistinct. Spiracles unequal in size, the first the largest, the tenth the smallest. Body hairs sparse, somewhat more abundant on the prothorax. Of three types: (1) A very few simple, minute (0.018-0.054 mm), flexible hairs on the ventral surface of the thorax; (2) hairs with denticulate tip, short (0.036-0.081 mm), generally distributed; (3) nearly straight two-hooked uncinat hairs, mod-

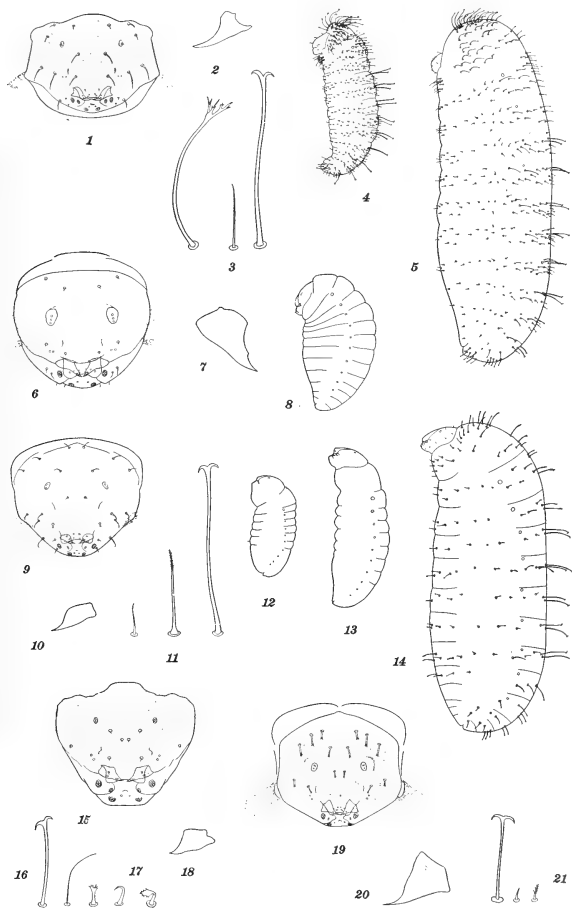

FIG. 5.—1-5, *Crematogaster (Crematogaster) acuta* (Fabricius): 1, Head in anterior view,  $\times 86$ ; 2, left mandible in anterior view,  $\times 216$ ; 3, three body hairs,  $\times 185$ ; 4, young larva in side view,  $\times 20$ ; 5, mature larva in side view,  $\times 20$ . 6-8, *C. (Orthocrema) minutissima missouriensis* Emery: 6, Head in anterior,  $\times 95$ ; 7, right mandible in anterior view,  $\times 216$ ; 8, young larva in side view (hairs omitted),  $\times 33$ . 9-14, *C. (O.) limata dextella* Santschi: 9, Head in anterior view,  $\times 95$ ; 10, left mandible in anterior view,  $\times 216$ ; 11, three body hairs,  $\times 185$ ; 12, very young larva in side view (hairs omitted),  $\times 32$ ; 13, young larva in side view (hairs omitted),  $\times 32$ ; 14, mature larva in side view,  $\times 32$ . 15-17, *C. (O.) brevispinosa* Mayr: 15, Head in anterior view,  $\times 167$ ; 16, three types of body hairs,  $\times 185$ ; 17, two views of the fourth type of body hair,  $\times 185$ ; 18, left mandible in anterior view,  $\times 216$ . 19-21, *C. (Physocrema) deformis* F. Smith: 19, Head in anterior view,  $\times 76$ ; 20, left mandible in anterior view,  $\times 216$ ; 21, three body hairs,  $\times 185$ .

erately long (about 0.18 mm), about four in a row across the dorsal surface of each abdominal somite I-V. Head subhexagonal in anterior view, narrowed ventrally; dorsal and ventral outlines convex; breadth about equal to length; dorsal and dorsolateral areas thin and depressed; mouth parts very small. Inside the head, just above the level of the mouth parts, there is a slender transverse sclerotic bar; each end of the bar turns upward and comes to the surface in the gena. Antennae small, with two sensilla each. Head hairs sparse, short (about 0.018 mm), simple and slightly curved. Labrum very small, short (breath  $3\frac{1}{2}$  times length), bilobed due to a deep concave incision of the ventral border; anterior surface with four isolated and two agglomerated sensilla on each half; posterior surface with two isolated sensilla on each half; ventral border with a few spinules. Mandibles very small, moderately sclerotized, with a moderately wide base tapering to a sharp point, which is slightly curved medially. Maxillae small; apex paraboloidal and directed medially; palp represented by three agglomerated sensilla; galea represented by two agglomerated sensilla. Labium small; palp represented by three agglomerated sensilla; a minute sensillum between each palp and opening of sericteries; the latter a short transverse slit. (Material studied: Numerous larvae from Panama Canal Zone.)

**JUST-HATCHED LARVA:** Length 0.6 mm. Head on the anterior end; relatively large; apparently without hairs. Body almost hairless; the uncinat hairs of the adult are represented by small tubercles, each surrounded by its alveolus and articular membrane.

**YOUNG LARVA:** Length about 1.0 mm. Similar to the mature larva but the head relatively larger and on the anterior end; body hairs relatively longer and seemingly more abundant. Segmentation distinct on the anterior half.

**Crematogaster (Orthocrema) brevispinosa** Mayr  
Fig. 5 (15-18)

**SEXUAL FORM:** Plump, chunky, and turgid; subovoidal, narrowed anteriorly; head ventral, near the anterior end. Anus posteroventral. Spiracles unequal in size; the first much the largest, the rest approximately equal. Integument of the posterior abdominal somites spinulose. Body hairs sparse, of four types: (1) Simple and very slender, a few on the lateral and dorsal surfaces, 0.018-0.07 mm long; (2) with the apex

broad, flat and denticulate, minute (about 0.018 mm), a few on the ventral surface of the mesothorax, metathorax and abdominal somites I-IX; (3) minute (about 0.018 mm), stout, with frayed tip, on the dorsal surface of the prothorax, mesothorax and abdominal somites IX and X, and on the ventral surface of the prothorax and abdominal somite X; (4) nearly straight two-hooked uncinat hairs, short (about 0.087 mm), three or four in a row across the dorsal surface of each abdominal somite I-V. Head subtrapezoidal in anterior view (but with a median dorsal truncate production), narrowed below; about as long as broad; integument somewhat sclerotized. Antennae minute, with three or four sensilla. Head hairs very few minute (about 0.006 mm) and simple. Labrum very small, short (length one-third the width), bilobed due to the concavity of the ventral border; anterior surface with two sensilla on each half; posterior surface with eight scattered sensilla; ventral border with a few spinules. Mandibles small; moderately sclerotized; basal two-thirds slightly inflated; apical one-third slightly curved medially and tapering rapidly to a sharp point. Maxillae small; apex paraboloidal and directed medially; palp represented by four agglomerated sensilla; galea represented by two agglomerated sensilla. Labium small; palp represented by four agglomerated sensilla; a minute sensillum between each palp and opening of sericteries; the latter a short transverse slit. (Material studied: Several larvae from Panama Canal Zone.)

**Crematogaster (Orthocrema) brevispinosa tumulifera** Forel

Similar to *brevispinosa* s. str. (Material studied: Several sexual larvae from Panama).

**Crematogaster (Orthocrema) dispar** Forel

Wheeler (1933, p. 89) stated that the queen larvae of a variety of this species "were nearly spherical and resembled pearls."

**Crematogaster (Orthocrema) minutissima missouriensis** Emery

Fig. 5 (6-8)

Leg and gonopod vestiges present. Spiracles unequal in size, the first much the largest, the rest diminishing gradually. Integument of the dorsal surface of the posterior somites sparsely spinulose, the spinules isolated and rather coarse. Head subcircular in anterior view, with the dorsal region thin and depressed. A slender sclero-

tized bar extends, just inside the gena, from the mandible to the level of the antennae; at its middle a stouter branch passes out and enters the prothorax. Antennae moderately large and drumlin-shaped, with three sensilla each. Labrum small, width 2.7 times the length, bilobed owing to the concavity of the ventral border; anterior surface of each half with four or five isolated and two agglomerated sensilla; posterior surface with four isolated sensilla on each half. Mandibles small, moderately sclerotized, subtriangular, with the apex slightly curved medially; medial border bearing a low, blunt tooth. Maxillae small; apex paraboloidal; palp a low knob bearing four or five sensilla; galea represented by two agglomerated sensilla. Labium small; palp a low knob bearing four sensilla; a minute sensillum between each palp and opening of sericteries; the latter a short transverse slit.

**YOUNG LARVA:** Length 0.77 mm. Plump and chunky, dorsal profile C-shaped, ventral profile sinuous; head ventral, near the anterior end; posterior end round-pointed. Anus ventral. Segmentation distinct on the anterior half; indistinct posteriorly. Other characters apparently as in the mature larva. (Material studied: One mature larva, one semipupa and a dozen young—all damaged—from Oklahoma.)

**Crematogaster (Orthocrema) quadriformis roveretoi** Forel

Eidmann, 1936, p. 42: "Die Larven sind spärlich behaart und zeigen im übrigen keine bemerkenswerten Besonderheiten."

**Crematogaster (Physocrema) deformis** F. Smith  
Fig. 5 (19-21)

Plump, chunky, and turgid; straight and sub-ellipsoidal; head flattened against the ventral surface near the anterior end. Anus ventral. Leg and gonopod vestiges present. Segmentation indistinct. Spiracles unequal in size, the first much the largest, the rest diminishing gradually. At the posterior border of each thoracic somite in the ventrolateral portion of the intersomatic groove is an integumentary structure that looks like a series of transverse folds or ridges; also in the intersomatic grooves between the thoracic and between the anterior abdominal somites are dark staining (with acid fuchsin) transverse bands on the dorsal and ventral surfaces. Body hairs exceedingly sparse, most abundant on the ventral surface of the prothorax. Of three types:

(1) Simple, minute (0.009-0.018 mm); (2) stout, denticulate or with frayed tip, minute (about 0.018 mm), on the ventral surface; (3) nearly straight two-hooked uncinat hairs, about 0.09 mm long, about four in a row on the dorsal surface of each abdominal somite I-V. Head subhexagonal in anterior view; integument sclerotized; from each ventrolateral corner of the head a large sclerotized structure passes out and enters the prothorax; mouth parts small. Antennae small, with three sensilla each. Head hairs sparse and short (0.018-0.036 mm), stout, with the tip frayed. Labrum very small, short (width  $3\frac{1}{2}$  times the length), bilobed due to a concavity of the ventral border; each half of the anterior surface with three isolated and two agglomerated sensilla; posterior surface with one sensillum on each half. Mandibles small, subtriangular; base broad; tapering to a long slender sharp point, which is curved medially. Maxillae small, apex paraboloidal and directed medially; palp a slightly raised cluster of four agglomerated sensilla; galea represented by two agglomerated sensilla. Labium small; palp a slightly raised cluster of four agglomerated sensilla; a minute sensillum between each palp and opening of sericteries; the latter a short transverse slit. (Material studied: Seven damaged integuments from Java.)

**Crematogaster (Sphaerocrema) striatula** Emery

Eidmann, 1944, p. 448: "Eben geschlüpfte Eilarven . . . fallen durch ihre gedrungene, kaum gekrümmte Gestalt auf, die Rückseite der Abdominalsegmente ist mit Reihen grosser ankerförmiger Oncochäten besetzt."

LITERATURE CITED

(A Bibliography of the Larvae of the Crematogastrini)

- ATHIAS-HENRIOT, C. *Recherches sur les larves de quelques fourmis d'Algérie*. Bull. Biol. France Belgique **81**: 247-272, 5 figs. 1947.
- BERLESE, A. *Osservazioni su fenomeni che avvengono durante la ninfosi degli insetti metabolici*. Riv. Patologia Vegetale **9**: 177-344, 95 figs. 1902.
- BRISTOWE, W. S. *Insects and other invertebrates for human consumption in Siam*. Trans. Ent. Soc. London **80**: 387-404, 1 fig. 1932.
- EIDMANN, H. *Die Ameisenfauna der Balearen*. Zeitschr. Morphol. Ökol. Tiere **6**: 694-742, 14 figs. 1926.
- . *Nest und Larve von Crematogaster scutellaris Oliv.* Ent. Mitteil. **16**: 18-19. 1927.
- . *Zur Kenntnis der Biologie der Rossameise*

- (*Camponotus herculeanus L.*). Zeitschr. Angew. Ent. **14**: 229-253, 9 figs. 1928.
- *Ökologisch-faunistische Studien an südbrasilianischen Ameisen.* Arb. Phys. Angew. Ent. Berlin-Dahlem **3**: 26-48, 81-114, 1 pl., 5 text figs. 1936.
- *Zur Kenntnis der Crematogaster impressa Em. (Hym. Formicidae) und ihrer Gäste.* Zool. Anz. **136**: 207-220, 5 figs. 1941.
- *Die Ameisenfauna von Fernando Poo.* Zool. Jahrb., Abt. Syst., **76**: 413-490, 1 pl., 17 text figs. 1944.
- GANTES, H. *Morphologie externe et croissance de quelques larves de Formicidés.* Bull. Soc. Hist. Nat. Afrique du Nord **4**: 71-97, 6 pls. 1949.
- MENOZZI, C. *Formiche della Somalia italiana meridionale.* Mem. Soc. Ent. Ital. **9**: 76-130, 3 pls., 4 figs. 1930.
- STÄRCKE, A. *Contribution to the biology of Myrmica scheneki Em.* Tijdschr. Ent. **91**: 25-71, 50 figs. 1948.
- WHEELER, G. C., and WHEELER, E. H. *A new species of Schizaspidia (Eucharidae), with notes on a eulophid ant parasite.* Psyche **31**: 49-56, 2 figs. 1924.
- WHEELER, W. M. *Colony-founding among ants, with an account of some primitive Australian species: x + 179 pp., 29 figs.* Harvard Univ. Press. 1933.

ZOOLOGY.—*Notes on the history and distribution of the reptiles.* AUSTIN H. CLARK, U. S. National Museum.

Reptiles differ from mammals and birds in being cold blooded. They agree with birds in having a relatively dry skin and in being highly dependent on sunlight. More dependent on sunlight than birds, nearly all live in sunny regions, especially in more or less arid, though not excessively arid, regions. Nearly all reptiles lay eggs like birds, but the young emerge from the eggs in the adult form and are not tended or fed by the parents. Nearly all modern reptiles are carnivorous, largely insect-feeders, like most birds, at least when young. Except for being cold blooded, the reptiles in the broader aspects of their ecology are more similar to the birds than they are to any other vertebrates. Morphologically they have been united with the birds under the inclusive term Sauropsida. But some reptiles are viviparous and some are wholly aquatic, as the sea snakes. Some have horny beaks like birds, others uniform or diversified teeth. In the past a number had the power of flight, their wings being essentially like those of the mammalian bats, not like those of birds.

Whereas since the Eocene the mammals and birds have undergone continuous and great diversification with adaptations for the constantly changing conditions and are today the dominant terrestrial vertebrates, the history of the reptiles has been quite different. In the Mesozoic the reptiles had reached a high degree of development and specialization and were highly diversified. There were, among others, gigantic, chiefly herbivorous, dinosaurs, great marine rep-

tiles of various kinds, and several types of flying reptiles, together with the more familiar crocodiles, turtles, and snakes. The development of the reptiles reached a culmination in the Cretaceous, but toward the end of that period most of them disappeared. Up to the end of the Cretaceous there were 19 orders of reptiles, but since the earliest Tertiary, when there were a very few reminders of the exceedingly rich Mesozoic fauna, only 4 of these have persisted, the Rhynchocephalia, represented only by *Sphenodon* or *Hatteria*, the tuatara of New Zealand; the crocodiles, confined to tropical and subtropical regions; the turtles; and the Squamata, including the lizards and snakes.

The world-wide and practically simultaneous disappearance of most of the reptiles, including all the giant terrestrial herbivores and carnivores, the flying pterodactyls, and the large ichthyosaurs, plesiosaurs, and mosasaurs, was followed by the evolution and development from mammalian stock of a great variety of types occupying the former habitats of all the terrestrial reptiles, with the cetaceans replacing the marine types. Presumably the place of the flying reptiles was taken by certain birds.

Any satisfactory explanation of the sudden disappearance of the dominant reptiles and their rapid replacement by mammals must be applicable equally to all the continents and to all the oceans as well. In view of the dependence of practically all modern reptiles, especially those with heavy skeletons or dermal scutes such as the hard shelled turtles and the crocodilians, on

abundant sunlight, and the independence of sunlight characteristic of the largely nocturnal mammals, it would seem that a radical change in the amount or character of the sun's radiations reaching the earth may well have been the chief factor in the disappearance of the reptiles which prepared the way for the domination of the mammals.

During the Cretaceous there was extensive inundation of the land areas by the sea, the continents were much isolated, and the climate presumably was warm and uniform. At the end of the Cretaceous there seems to have been a great upheaval of the land in both the northern and southern hemispheres. This was accompanied by local and intermittent volcanic activity throughout the Eocene in the Rocky Mountain region, Central America, the West Indies, and southern Europe. Any marked increase in the land areas would mean a corresponding increase in dust in the atmosphere, inorganic dust from arid areas and pollen and other organic dust from heavily vegetated regions. Volcanic activity would also produce a large amount of atmospheric dust.

Of interest in regard to the latter is the information on the eruption of Krakatoa, between Sumatra and Java, on May 26-28, 1883. In this eruption the height of the ejected column of stones, ashes, and dust was estimated to have reached 17 miles or more. The finer particles were diffused over a large part of the earth and were carried over North and South America, Europe, Asia, South Africa, and Australia. In the Old World they spread from Scandinavia to the Cape of Good Hope. And this is the record of only a single isolated eruption.

With increase in land areas and intermittent volcanic eruptions the illumination of the surface of the earth would be considerably altered. Whereas the extensive inundation of the land areas during the Cretaceous would presumably clear the atmosphere, giving rise to conditions especially favorable to reptiles, increase in land areas, especially in connection with volcanic activity, would make conditions unfavorable for reptiles while at the same time permitting the rapid increase and diversification of mammals.

In their present distribution the land reptiles fall into two main groups. The

strictly terrestrial forms, such as the lizards and most snakes, follow largely the distributional pattern of the mammals except that they do not range so far north or south and, possibly because of their greater age, there are among them more striking cases of discontinuous distribution resulting from extirpation over a large portion of the original range. In the mammals examples of discontinuous distribution are the camels, originally North American but now represented only by two wild species in South America, two domesticated species in South America, and two domesticated species in Asia one of which has been introduced into Africa; the tapirs once widespread but now restricted to tropical America and the Malay Peninsula, Sumatra, and Borneo; and the fresh-water dolphins of South America, India, and China; but the last may have been originally marine.

In the Pleistocene many mammals spread from Asia into North America, and from North America into Asia, but apparently the connection between these continents was too far north to serve as a highway for any reptiles. Some examples of discontinuous distribution in the reptiles are, the Gila monsters (*Helodermatidae*), Texas, Arizona, Mexico, and Borneo; the large herbivorous iguanas, tropical America, Madagascar, and Fiji; the pythons, tropics of the Old World and western Mexico; and the burrowing *Amphisbaena*, South America and Africa. The true land tortoises (*Testudo*) are found in all tropical and warm temperate regions except Australia.

The amphibious reptiles, the crocodylians and the fresh-water turtles, present a more generalized distributional picture resembling that of the amphibians rather than that of the mammals presumably owing both to their greater age than mammals and the fact that aquatic habitats are much less variable than terrestrial, the chief differential here being extratropical changes in temperature. True crocodiles (*Crocodylus*), appearing first in the Cretaceous, still occur throughout the tropics. The gavials and alligators appear in the Miocene; the gavials are now confined to southern Asia, the alligators (with the caymans) to America, with one alligator in southern China. Among the

fresh-water turtles the soft-shelled type, appearing first in the Cretaceous, still occurs in Asia, Africa, and America, as far north as Canada; the Pelomedusidae are found in Africa and South America; and the snake-necked turtles in South America, Australia, and New Guinea.

Briefly stated, the history and present distribution of the reptiles seem to be dependent upon their special ecological char-

acteristics, which differ from those of any of the other vertebrates in their dependence upon certain elements of sunlight and their relative independence of a constant supply of external water. Their former distribution is most closely parallel to that of the succeeding mammals, while their present distribution is mainly parallel to that of mammals with some forms having a distribution parallel to that of the amphibians.

ZOOLOGY.—*Poritextularia*, a new Recent foraminiferal genus.<sup>1</sup> ALFRED R. LOEBLICH, JR., and HELEN TAPPAN, U. S. National Museum.

During generic studies of the smaller Foraminifera, the writers have encountered numerous species that do not agree with the generic diagnosis of the genera to which they have been referred. In order that the foraminiferal genera should be more precisely defined, the writers are excluding many such species from genera that have already been well defined. In the present paper a new generic name is proposed for a species in the family Textulariidae which was previously referred to *Textularia panamensis* Cushman. In a recent article by Loeblich (1952, p. 190) it was inferred that this species might belong to *Tawitawia* Loeblich as it was very similar to the genotype species of *Tawitawia*. At that time, no specimens of the present form were available for study, but the writers have subsequently had the opportunity of examining a suite of specimens of this species. Although similar externally, the two species differ in both their apertural character and internal structure. The new genus *Poritextularia* here described, like *Tawitawia*, is a specialized off-shoot from *Textularia*, that has evidently developed in Recent times.

The writers are indebted to Dr. Irene McCulloch, Allan Hancock Foundation, University of Southern California, for making available a fine suite of specimens for study.

#### Family TEXTULARIIDAE

Genus *Poritextularia* Loeblich and Tappan, n. gen.

Genotype (type species): *Poritextularia mexicana* Loeblich and Tappan, n. sp.

<sup>1</sup> Published by permission of the Secretary of the Smithsonian Institution.

Test free, compressed, biserial throughout; wall agglutinated, interior simple; aperture consisting in the early stages of an elongate slit at the base of the last chamber, paralleling the sides of the test, and in the adult consists of a linear series of openings across the terminal portion of the final chamber, formed by the development of pillars across the original slit.

*Remarks*.—This genus resembles *Textularia* Defrance in the biserial agglutinated test, but differs in having a multiple aperture. It resembles *Tawitawia* Loeblich in the large flattened biserial test with a rather extreme overlap of chambers and multiple aperture, but differs in having a simple interior, lacking the internal pillars and labyrinthic structure of the latter genus, and in being completely biserial with no tendency to become uniserial. The aperture of *Tawitawia* is completely terminal and does not extend to the base of the final chamber as in *Poritextularia*.

*Poritextularia mexicana* Loeblich and Tappan, n. sp.

Figs. 1-3

*Textularia panamensis* Cushman, Lalicker and McCulloch (not Cushman, 1918), Allan Hancock Pacific Exped. 6 (2): 136, pl. 15, figs., 18 a-e. 1940.

Test free, biserial throughout, rhomboid in outline, much compressed, sides flat; chambers numerous, low and broad, increasing gradually in size from the rounded proloculus, very oblique, highest at the mid portion of the test and bending downward to the margins; sutures distinct, depressed, strongly oblique, slightly curved upwards; wall finely arenaceous, with occasional large black mineral grains included (shown on final pair of chambers in Fig. 1 and to the right margin of Fig. 2), interior simple, not labyrinthic; aperture in the early stages consisting of an elon-



gate slit at the base of the last chamber, paralleling the flat sides of the test, which in the adult may be bridged by pillars so that the former slit is broken up into a linear series of small pore-like openings extending from the base across the terminal portion of the final chamber.

Length of holotype (Fig. 1) 1.85 mm, breadth 1.22 mm, thickness 0.23 mm. Length of paratype of Fig. 2 1.87 mm, breadth 1.43 mm, thickness 0.23 mm. Length of paratype of Fig. 3 1.82 mm, breadth 1.20 mm, thickness, 0.23 mm.

*Remarks.*—This species was described and illustrated by Lalicker and McCulloch (1940, p. 136, pl. 15, fig. 18) but was referred to *Textularia panamensis* Cushman. *Textularia esperoni* Applin was placed in the synonymy of *T. panamensis* in this publication, but the present writers believe Applin's species to be distinct from both Cushman's species and the present form. *Textularia esperoni* is a small, parallel-sided species with a diamond-shaped cross section, much thicker along the central zigzag suture than at the periphery. The chambers are comparatively high and pro-

duced into spines at the margins. The aperture is "a well-arched opening at the base of the last-formed chamber."

*Textularia panamensis* is larger than *T. esperoni*, has a rhomboid outline, but is extremely flattened, and the chambers are very low and broad. The aperture was described as "indistinct," but examination of additional specimens from the Miocene Gatun formation, near the Gatun Railroad Station, shows the aperture to consist of a well-defined triangular opening at the base of the last chamber, which does not extend far up the apertural face.

The species *T. panamensis* Cushman, 1918, and *T. esperoni* Applin, 1925, are both true *Textularia* and quite distinct from the present species, which has much more strongly overlapping chambers, a larger test approximately three times as large, and the aperture varying from a very elongate slit beginning at the base of the last chamber to a multiple aperture consisting of a linear series of openings.

*Types and occurrence.*—Holotype (USNM P.

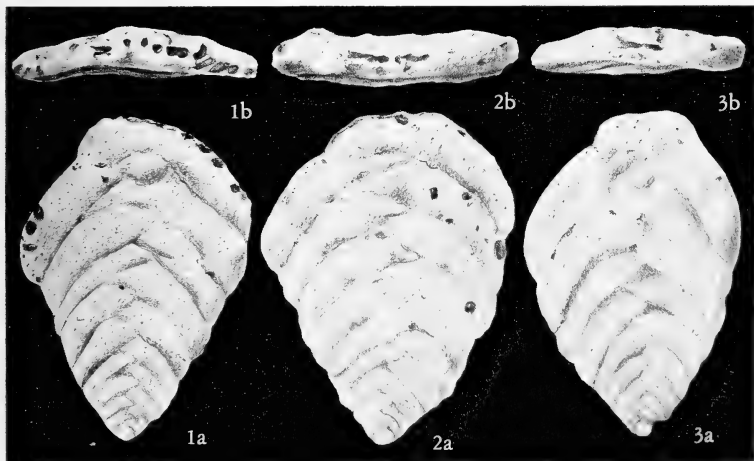

FIGS. 1-3.—*Poritextularia mexicana* Loeblich and Tappan, n.sp.: 1a, side view of holotype (USNM P. 839) showing broad flat test, strongly overlapping chambers, and dark mineral grains on final two chambers; 1b, top view showing aperture beginning as an arch at the base of the chamber and extending as a linear series of pores across the top of the final chamber (four black mineral grains are present at the right side of the chamber nearly in line with the aperture and should not be confused with the aperture); 2a, side view of paratype (USNM P. 840 a); 2b, top view showing long slitlike aperture interrupted by a single pillar; 3a, side view of paratype (USNM P. 840 b); 3b, top view showing shorter slitlike aperture uninterrupted by pillars. (All figures camera-lucida drawings by Sally D. Lee, scientific illustrator, Smithsonian Institution.)

839) figured paratypes (USNM P. 840 a-b) and unfigured paratypes (USNM P. 841 a-e) all from Allan Hancock Expedition station 2060, Point Piaxtla, Sinaloa, Mexico, lat. 23°33' N., long. 106°46' W., in 8 fathoms.

## REFERENCES

APPLIN, E. R., in APPLIN, E. R., ELLISOR, A. E., and KNIKER, H. T. *Subsurface stratigraphy of the coastal plain of Texas and Louisiana.*

Bull. Amer. Assoc. Petr. Geol. Bull. **9**: 79-122. 1925.

CUSHMAN, J. A. *The smaller fossil Foraminifera of the Panama Canal Zone.* U. S. Nat. Mus. Bull. **103**: 45-87, pls. 19-33. 1918.

LALICKER, C. G., and McCULLOCH, I. *Some Textulariidae of the Pacific Ocean.* Allan Hancock Pacific Exped. **6**: 115-143, pls. 13-16. 1940.

LOEBLICH, A. R., JR. *New Recent foraminiferal genera from the tropical Pacific.* Journ. Washington Acad. Sci. **42**: 189-193. 1952.

MALACOLOGY.—*A new glycymerid from the Western Atlantic.*<sup>1</sup> DAVID NICOL, U. S. National Museum.

While examining *Glycymeris americana* in the U. S. National Museum collection, I found specimens of an undescribed species of Recent glycymerid which had been labeled *G. undata* (Linné), *G. decussata* (Linné), *G. pennacea* (Lamarck), *G. lineata* (Reeve), and *G. americana* (Defrance). These many names indicate that the Western Atlantic glycymerids are in need of a thorough study.

I am greatly indebted to William J. Clench and T. E. Pulley, of the Museum of Comparative Zoölogy, for the loan of specimens for examination.

*Glycymeris spectralis* Nicol, n. sp.

Figs. 1, 2

*Description.*—Shell, with one exception, longer than high; ratio of convexity to height about 0.68; valve outline ovate to subtriangular, with the posterior side produced and commonly truncated; beaks opisthogyrate and located at about the posterior fourth of the ligamental area; umbos small; ligament small and short with about six ligamental chevrons which are better developed on the anterior side; hinge plate narrow; hinge teeth small, about 25 in number; radial ribs rather narrow, raised slightly, separated by narrow interspaces, ribs and interspaces covered by radial

striae; periostracum well-developed, velvety; crenulations on inner ventral border large and widely spaced for the size of the shell, 6 or 7 per cm on specimens of from 20 to 25 mm in height; color pattern variable, some specimens show distinct rays of reddish-brown exteriorly; interior of some specimens may be white or light to dark brown, color better developed on the posterior side of the shell.

*Measurements in mm.*—The numbers that follow the words holotype and paratype are U. S. National Museum catalogue numbers.

	Height	Length	Convexity
Holotype 598668	19.2	20.5	13.0
Paratype 522645	22.0	21.8	14.4
Paratype 522645a	14.0	14.8	8.8
Paratype 223632	22.0	24.7	15.8
Paratype 223632a	21.6	23.4	15.2
Paratype 223632b	16.2	18.3	11.2
Paratype 223632c	17.0	19.1	11.7
Paratype 223632d	17.3	19.6	12.0
Paratype 36421	21.6	24.5	14.2
Paratype 36421a	20.6	21.2	14.4
Paratype 599298	17.7	18.4	11.3
Paratype 599298a	14.9	16.6	10.1
Paratype 599298b	13.2	14.2	8.0
Paratype 486218	15.2	16.7	9.9
Paratype 486218a	14.4	16.1	9.3
Paratype 36418	21.9	23.0	14.7
Paratype 92393	21.3	23.6	14.3
Paratype 598667	24.2	25.8	17.6
Paratype 486294	27.6	29.4	20.2
Paratype 406841	16.6	17.8	11.2
Paratype 406841a	15.2	15.9	9.2
Paratype 83135	5.2	5.9	3.6
Paratype 124780	20.5	22.8	15.7
Paratype 515910	19.7	20.3	13.9
Paratype 364579	22.9	25.2	17.0
Paratype 364579a	16.9	18.1	12.3
Paratype 364706	18.8	21.4	14.6
Paratype 364706a	17.6	19.2	12.8
Paratype 364706b	8.1	9.0	5.9
Paratype 543835	22.7	25.4	15.8
Paratype 543835a	20.6	22.4	13.5
Paratype 543835b	19.2	21.9	13.2
Paratype 543835c	18.8	21.1	11.8
Paratype 543835d	18.8	22.2	11.9
Paratype 543835e	15.0	16.8	9.9
Paratype 543835f	14.7	16.7	9.2
Paratype 543835g	13.5	14.9	8.7
Paratype 486540	16.6	18.0	11.1

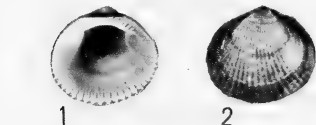

FIGS. 1, 2.—*Glycymeris spectralis* Nicol, n. sp., holotype (U.S.N.M. no. 598668). Recent, from Boynton on Lake Worth, Palm Beach County, Fla.: 1, interior, right valve; 2, exterior, left valve. Natural size.

<sup>1</sup> Published by permission of the Secretary of the Smithsonian Institution.

*Types.*—Holotype, U.S.N.M. no. 598668 (Division of Mollusks). There are 37 paratypes in the



ICHTHYOLOGY.—*Revision of the genus Talismania, with description of a new species from the Gulf of Mexico.* A. E. PARR, American Museum of Natural History. (Communicated by Leonard P. Schultz.)

The segregation of *Nemabathytroctes* from *Talismania* has always rested almost exclusively upon the presence of produced fin rays at least in the pectorals of the former. In 1951 the writer (Parr, 1951, p. 11) restricted *Talismania* to the genotype, *T. homoptera* (Vallant, not *T. homoptera* of other authors), with the other species usually identified as *T. homoptera* transferred to the family Searsidae, and those referred to the genus *Talismania* under other specific names placed in the genera *Rouleina* and *Binghamichthys*. Thus restricted, *Talismania* agreed with *Nemabathytroctes* in all basic features, such as the length of the snout, lateral dentition of premaxillaries, and structure of opercular bones. But a fairly sharp distinction still existed between the two species referred to *Nemabathytroctes* and the only recognized species of *Talismania*, in regard to the size of the head, the dimensions of the jaws, the apparent form (depth) of the body, and other features (see the key on p. 269). With the type of *T. homoptera* no longer giving any evidence of produced pectoral rays, the generic identity of this genus and species with *Nemabathytroctes* therefore still remained unsuspected.

The discovery of another new species, unquestionably representative of *Nemabathytroctes*, but with heads and jaws in the proportions characteristic of *Talismania homoptera*, and with the produced rays of pectoral fin relatively weaker and less thickened than in the other species of *Nemabathytroctes*, has now given new significance to Vallant's previously neglected description of the pectorals of *T. homoptera* as being elongated so as to reach to, or even beyond, the insertion of the ventrals. It is therefore now obvious that *Talismania* and *Nemabathytroctes* are identical genera, differing only by their type species but not by any characters of generic significance.

The relatively slender body measurements of *T. homoptera* are governed by the dimensions of the soft parts only and can be largely explained by the state of the specimen, in

which the stomach is missing and the other soft parts seem shrunken or in a naturally poor state of nutrition.

The great over-all length of the head in *T. bifurcata* is largely due to the long dermal flap of the gill cover, which extends well beyond the insertion of the anterior (upper) ray in pectoral fin. When skeletal measurements are used, such as the distance from the snout to top of preopercle, the differences between the various species in regard to the general size of the head become less clear and significant, and one can only say that snout to preopercle is more than (28 — .02L) percent of L in *T. longifilis*, less than (28 — .02L) but more than (25 — .02L) percent of L in the other species. A similar situation obtains in regard to the distance from snout to pectorals, which is more than (42 — .02L) percent of L in *T. longifilis*, less than (41 — .02L) but more than (38 — .02L) in the others.

There is undoubtedly a valid difference between *T. bifurcata* and *T. oregoni* in regard to the length of the dermal flap of the gill cover, and thus also in regard to the over-all length of the head. But the size of the dermal flap of *T. homoptera* can unfortunately not be determined with any degree of certainty in the present state of the type specimen.

It is, therefore, in the dimensions of the jaws relative to each other and to the length of the specimen, rather than in the general dimensions of the head, that we find the most significant and useful proportions for the differentiation of the species, in correlation with other features.

Genus *Talismania* Goode and Bean, 1895

*Bathytroctes*, subgenus *Talismania* Goode and Bean, 1895, p. 43 (*partim*, genotype, *B. homopterus*, only);  *nec* Norman, 1930, p. 269;  *nec* Fowler, 1934, p. 249.

*Talismania* Jordan and Evermann, 1896, p. 455 (*T. homoptera*, only); Roule, 1919, p. 6 (*T. homoptera*, only); Parr, 1951, pp. 5, 11;  *nec* Koefoed, 1927, p. 55.

*Bathytroctes*, subgenus *Nemabathytroctes* Fowler, 1934, p. 252.

*Nemabathyroctes* Parr, 1937, p. 7; Parr, 1951, pp. 5, 10.

Pectorals with 11-12 rays, upper ray greatly produced. Dorsal and anal fins subequal and approximately opposite. Caudal fin with produced lobes (in the species in which the caudal fin has been preserved). Ventral fins inserted near the middle of the length, with 6-7 rays.

Heads large, not less than (38 - .02L) percent of L. Snouts long, 10-12, or more than ? (13 - .02L) ?, percent of L. Mouth large, lower jaws more than (20 - .02L) percent of L. Premaxillaries of normal shape but with a short external series of horizontal teeth anteriorly, well above the regular dentition at the edge of the mouth. Teeth otherwise in single series in premaxillary, maxillary, lower jaw and palatine, and in one or two transverse rows on vomer. Maxillary series as long as, or longer than that of the premaxillary. Two supramaxillaries, with slight or no mobility relative to maxillary.

Head pointed in lateral view, with a virtually straight dorsal profile ending at a slightly prominent snout, marked by the upper, horizontal dentition of the premaxillaries.

Gill opening wide, extending upward to, or nearly to, the level of the upper margin of orbit. Operculum moderate to large, extending well above its attachment to hyomandibular. Suboperculum large, varying in form with the species. Interoperculum normal. Preoperculum rather wide, its upper limb subvertical. Branchiostegals 6-8.

Stomach siphonal; 8-10 simple pyloric caeca. Anus near anal fin.

Body scaly, head without scales. No shoulder organ. Apparently luminous organs present in orbital cavity of at least one species.

Our knowledge of the genus is based upon only five specimens of the following sizes and sex: *T. longifilis* 116 mm L (i.e., length without caudal fin), immature. *T. homoptera* 161 mm L. Internal organs missing. *T. bifurcata* 202 mm L, mature female. *T. oregoni* 240 and 246 mm L, mature females.

These dimensions should be borne in mind in evaluating the statements of relative proportions given in the following key by use of the expressions proposed by Parr, 1949.

The condition of the type specimen of *T. homoptera* leaves the exact form of the posterior margin of the subopercle in doubt. It can be

definitely established only that the lower posterior corner of the suboperculum ends rather bluntly with a group of 3 or 4 very short and fine points, side by side at its tip. It is indicated that this species may not have any of the very long, widely separated, simple points higher up along the posterior margin of the subopercle, that seem characteristic of the other members of the genus, but the writer is not satisfied that this can be taken to be definitely proven by the type specimen as observed by him.

#### KEY TO THE GENUS TALISMANIA

A. Heads large, more than (41 - .02L) percent of L. Jaws very long, upper jaws about (23 - .02L), lower jaw (24.5 - .02L) percent of L. Produced pectoral rays very strong. Indo-Pacific.

1. Scales small, 90-95 in a longitudinal series, about 35 in a transverse count. Suboperculum with three separate points. Head about (41.5 - .02L) percent of L. Gulf of Aden.

*longifilis* (Brauer, 1902)

2. Scales larger, about 65-70 in a longitudinal series, about 22-23 in a transverse count. Suboperculum with only two long points. Head about (42.1 - .02L) percent of L. Gulf of Panama.

*bifurcata* (Parr, 1951)

B. Heads smaller, less than (40 - .02L) percent of L. Jaws much shorter, upper jaws less than (21 - .02L), lower jaw less than (21.5 - .02L) percent of L. Scales large, about 60-65 in a longitudinal series and about 20-24 in a transverse count. Produced pectoral rays not very strong. Atlantic.

1. Upper jaws extend beyond centre of eye but fall conspicuously short of reaching the vertical from the posterior margin of orbit, being about 2 percent of L shorter than lower jaw. Ventrals slightly behind the middle of body, snout to ventrals about 17 percent of L longer than snout to pectorals. Dorsal fin with only about 19 rays, its base about 2 percent of L shorter than base of anal fin. Eastern North Atlantic.

*homoptera* (Vaillant, 1888)

2. Upper jaws extend nearly to vertical from posterior rim of orbit, being less than 1 percent of L shorter than lower jaw. Ventrals slightly in advance of the middle of body, snout to ventrals only about 12.5 - 14.5 percent of L longer than snout to pectorals. Dorsal fin with 23 or 24 rays, its base not more than 1 percent of L shorter than the base of anal fin. Gulf of Mexico.....*oregoni*, n. sp.

*Talismania oregoni*, n. sp.

Jaws relatively short, but upper jaw less than one (.5–.8) percent of L shorter than lower jaw, equivalent to (20 – .02L) percent of L. Lower jaw equivalent to (20.5 – .02L) to (21.4 – .02L) percent of L. Upper jaw extends nearly to the vertical from the posterior rim of orbit. Head moderate, with rather short dermal flap of gill-cover, equivalent to (38 – .02L) to (39.8 – .02L) percent of L.

Subopercle ends posteriorly in three long separate points. Lower margin of lower subopercular point with minute, oblique serrations. Interorbital space flat.

Ventrals inserted slightly in advance of the middle of body, their distance from the snout only 12.5–14.5 percent of L longer than the distance from snout to pectorals. The longest remaining fragment of the produced pectoral finray equals about 35 percent of L. The full length of the produced ray would undoubtedly be substantially greater, although the proximal part is not particularly strengthened and thickened. The form of the caudal fin is unknown. The bases of dorsal and anal fins are about 19–21 percent of L.

The specimens show the following measurements and proportions, with those of the cotype given in parenthesis: Length without caudal fin: Type 240 mm (cotype 246 mm). Proportions in percent of length without caudal: Head, including dermal margin of gill cover, 35.0 (33.3). Snout 11.1 (10.2). Orbit 5.5 (5.7). Interorbital width 6.3 (5.4). Over-all length of upper jaws 15.8 (15.0). Lower jaw to external corner of angular 16.6 (15.5). Snout to top of preopercle 21.8 (20.3). Snout to dorsal fin 62.9 (64.5). Snout to anal fin 63.6 (62.9). Snout to pectorals 35.8 (33.2). Snout to ventrals 48.3 (47.7). Base of dorsal fin 20.4 (18.9). Base of anal 20.0 (20.7).

Greatest depth of body 22.7 (22.3). Least depth of caudal peduncle 8.5 (8.1).

D. 22½–24½. A. 23–23½. P. 12. V. 7. Br. 6–7. First gill arch with 7–8/1/17–18 gill rakers, longest only about 3.3 percent of L.

Stomach siphonal; 8 or 9 simple pyloric caeca, the longest 8.7–10.6 percent of L, substantially longer than those found in *T. longifilis* and *T. bifurcata*, but the significance of this difference is uncertain.

About 51 pores in lateral line, about 63–64 scales in a longitudinal series immediately above, about 11 between lateral line and origin of dorsal fin, and about 12 between lateral line and anal fin. There is no clear evidence of ventral or dorsal keels, except immediately before dorsal fin. But two median ventral scales preserved in the thoracic region suggest the presence of some kind of organ surrounded by black integument under the broad posterior point of each, while a single scale still present outside of the median shows only a narrow, black tip. No indications of whitish, luminous (?) bodies in orbits.

Gulf of Mexico. Oregon station 349. 29°09' Lat. N., 87°58' long. W. Depth 470–500 fathoms. May 21, 1951. Holotype, U.S.N.M. no. 160482. Cotype no. ?.

## BIBLIOGRAPHY

- BRAUER, A. *Diagnosen von neuen Tiefseefischen*. Zool. Anz. **25**: 277–298. 1902.
- FOWLER, H. W. *Descriptions of new fishes obtained 1907 to 1910 chiefly in the Philippine Islands*. Proc. Acad. Nat. Sci. Philadelphia **85**: 233–367. 1934.
- GOODE, G. B., and BEAN, T. H. *Oceanic ichthyology*. U. S. Nat. Mus. Spec. Bull. 2. 1895.
- JORDAN, D. S., and EVERMANN, B. W. *The fishes of North and Middle America*. Pt. I. U. S. Nat. Mus. Bull. 47. 1896.
- KOEFOD, E. *Fishes from the sea-bottom*. Rep. Sci. Res. Michael Sars N. Atlantic Exp. 1910, **4**: pt. 1. 1927.



FIG. 1.—*Talismania oregoni*, n.sp.: Supramaxillaries and opercular bones artificially exposed. Eye represented by orbit. Drawn by author.

- NORMAN, J. R. *Oceanic fishes and flatfishes collected in 1925-1927*. *Discovery Rep.* **2**: 261-370. 1930.
- PARR, A. E. *Concluding report on fishes*. (Third *Oceanogr. Exp. "Pawnee"*). *Bull. Bingham Oceanogr. Coll.* **3**: (art. 7). 1937.
- . *An approximate formula for stating taxonomically significant proportions of fishes with reference to growth changes*. *Copeia*, 1949 (1): 47-55. 1949.

- . *Preliminary revision of the Alepocephalidae*. *Amer. Mus. Nov.* 1531: 1-21. 1951.
- ROULE, L. *Poissons provenant des campagnes du yacht Princesse Alice et du yacht Hirondelle II*. *Res. Camp. Sci. Monaco*, fasc. 52. 1919.
- VAILLANT, L. L. *Poissons*. *Exp. Sci. Travailleur et Talisman*. Paris, 1888.

## PROCEEDINGS OF THE ACADEMY

### 456TH MEETING OF BOARD OF MANAGERS

The 456th meeting of the Board of Managers, held in the Cosmos Club on May 12, 1952, was called to order at 8:02 P.M. by President RAMBERG. Others attending were: H. S. RAPPEYE, J. A. STEVENSON, W. F. FOSHAG, A. T. MCPHERSON, C. F. W. MUESEBECK, R. G. BATES, W. R. WEDEL, W. A. DAYTON, C. A. BETTS, R. S. DILL, F. W. HOUGH, N. R. ELLIS, M. A. MASON, F. M. DEFANDORF, and, by invitation, E. H. WALKER and J. P. E. MORRISON.

The President announced the appointment of WALLACE R. BRODE as Chairman of the new Science Education Committee, other members to be announced at a later date.

A letter from the Chairman of the Committee on Meetings, HARRY W. WELLS, who could not be present, was read, requesting a change in the next meeting date to the fourth Thursday in October. This change in lieu of the regular meeting date on the third Thursday was approved by the Board, as it will insure a joint meeting with the Anthropological Society to be addressed by Dr. C. E. WILLIAMS.

MARTIN A. MASON reported mentioning the desire on the part of the Academy to collaborate with its Affiliated Societies at a meeting of the Council of the Civil Engineering Society. After the meeting Colonel Hough reported that he also had taken the matter up with the Society of Military Engineers and that they would be glad to take part in a joint symposium should such be arranged. Presumably this matter will be revived for discussion when meetings of other Affiliated Societies are resumed in the fall.

Mr. WALKER expressed his regrets that new members do not receive something other than a letter when they are first elected and actually know very little about the Academy and its aims. During the ensuing discussion by Messrs. Mason, Rappeye, Betts, Dayton, and others

it was indicated that the proposed supplemental list of members since the last issue of the Red Book (no longer available for distribution), although of use to those owning the last Red Book, would not be especially useful or its receipt gratifying to newly elected members. In addition to a complete Academy membership list, it would be desirable to have the Bylaws, something of the history, objectives, and aims of the Academy, and information as to the relationship of the Affiliated Societies, in printed form. The matter of the cost and labor of preparation involved was mentioned. The discussion was concluded by approval of a motion by Mr. Mason that the matter be referred to the Policy and Planning Committee to report at the first meeting in the fall their recommendations as to how new members should be initiated and what they should receive.

L. E. YOCUM, Chairman of the Committee on Grants-in-Aid for Research, on the basis of approval of his committee at a meeting on April 29, submitted a recommendation that an American Association for the Advancement of Science grant of \$200 be made to Dr. FREEMAN A. WEISS, curator of the American Type Culture Collection, for purchase of equipment to permit an examination of the Lederberg Process of preserving bacterial cultures by drying on silica gel. Details of the proposal were submitted. This grant was approved by the Board.

MARTIN A. MASON, Chairman, presented copies of a report for his Committee on a Junior Academy of Sciences. This report and the appended proposed Constitution and Bylaws for the Junior Academy were discussed by Messrs. Rappeye and McPherson. In view of the present Bylaws of the Academy, it was decided to submit to the membership an amendment to Article I, adding to it as one of the listed objectives a section "9. Sponsoring the Washington Junior Academy of Sciences" and a second permissive

amendment, Article XI, "The Academy may establish and assist a Washington Junior Academy of Sciences for the encouragement of interest in science among students." It was decided that a ballot for these amendments should be sent out within two weeks together with explanatory material and, for the information of the membership, a copy of the committee's report and the proposed Constitution and Bylaws for the Washington Junior Academy of Sciences.

The Secretary announced the receipt of notification of the death of Dr. GEORGE W. McCoy on April 2, 1952.

The Secretary reported for Vice President A. G. McNish, who was unable to attend the meeting, that the Philosophical Society of Washington had appointed a special committee composed of WILLIAM R. DURYEE (Chairman), I. C. GARDNER, and R. K. COOK to study and make recommendations as to suitable projection equipment and a

suitable public address system for equipping the new Auditorium of the Cosmos Club which is expected to be available for use in the fall. It was felt that the Academy and a number of its Affiliated Societies that will make use of the Auditorium will be interested in having excellent facilities available, and may therefore be interested as a group in providing desirable equipment. After a discussion, the President suggested that the Chairman of the Meetings Committee, HARRY W. WELLS, look into the matter with Mr. Duryee and express the interest of the Academy in this project.

J. A. STEVENSON, Archivist, commented that he found the reading of the early bound records of the Academy, turned over to him at the last meeting of the Board, very rewarding and mentioned several items of interest.

The meeting adjourned at 9:35 P.M.

F. M. DEFANDORF, *Secretary*.

## Obituary

OSCAR BENWOOD HUNTER died suddenly at Washington, D. C., on December 19, 1951, of a heart attack. He was born in Cherrydale, Va., on January 31, 1888. He received his medical degree from the George Washington University School of Medicine in 1912. In 1916 he received an A.B. degree and the following year an A.M. degree, both from the George Washington University. He served his alma mater as professor of bacteriology and pathology from 1916 to 1932 and assistant dean of the medical school from 1918 to 1932. He was an active member of numerous scientific societies where he served in official capacities. He was past president of the

Southern Medical Association, Medical Society of the District of Columbia, the George Washington University Medical Society, Washington Society of Pathologists and the American Therapeutic Society. He was also a founding member of the College of American Pathologists and served this college as local governor. Dr. Hunter was also a member of numerous other organizations, including many local clubs, the National Safety Council, Board of Trade, and the Chamber of Commerce of the United States. He served as major in the medical reserve corps, U. S. Army. At the time of his death he was vice-president of the American Medical Association.

WALTER A. BLOEDORN.



## Officers of the Washington Academy of Sciences

*President*.....WALTER RAMBERG, National Bureau of Standards  
*President-elect*.....F. M. SETZLER, U. S. National Museum  
*Secretary*.....F. M. DEFANDORF, National Bureau of Standards  
*Treasurer*.....HOWARD S. RAPPLEYE, U. S. Coast and Geodetic Survey  
*Archivist*.....JOHN A. STEVENSON, Plant Industry Station  
*Custodian and Subscription Manager of Publications*  
 HAROLD A. REHDER, U. S. National Museum

### *Vice-presidents Representing the Affiliated Societies:*

Philosophical Society of Washington.....A. G. McNISH  
 Anthropological Society of Washington.....WALDO R. WEBEL  
 Biological Society of Washington.....HUGH T. O'NEILL  
 Chemical Society of Washington.....JOHN K. TAYLOR  
 Entomological Society of Washington.....FREDERICK W. POOS  
 National Geographic Society.....ALEXANDER WETMORE  
 Geological Society of Washington.....A. NELSON SAYRE  
 Medical Society of the District of Columbia.....FRED O. COE  
 Columbia Historical Society.....GILBERT GROSVENOR  
 Botanical Society of Washington.....LEE M. HUTCHINS  
 Washington Section, Society of American Foresters.....WILLIAM A. DAYTON  
 Washington Society of Engineers.....CLIFFORD A. BETTS  
 Washington Section, American Institute of Electrical Engineers.....A. H. SCOTT  
 Washington Section, American Society of Mechanical Engineers.....RICHARD S. DILL  
 Helminthological Society of Washington.....L. A. SPINDLER  
 Washington Branch, Society of American Bacteriologists.....ANGUS M. GRIFFIN  
 Washington Post, Society of American Military Engineers.....FLOYD W. HOUGH  
 Washington Section, Institute of Radio Engineers.....HERBERT G. DORSEY  
 District of Columbia Section, American Society of Civil Engineers  
 MARTIN A. MASON  
 District of Columbia Section, Society for Experimental Biology and Medicine  
 N. R. ELLIS

### *Elected Members of the Board of Managers:*

To January 1953.....C. F. W. MUESEBECK, A. T. MCPHERSON  
 To January 1954.....SARA E. BRANHAM, MILTON HARRIS  
 To January 1955.....ROGER G. BATES, W. W. DIEHL

*Board of Managers*.....All the above officers plus the Senior Editor  
*Board of Editors and Associate Editors*.....[See front cover]

*Executive Committee*.....WALTER RAMBERG (chairman), F. M. SETZLER, H. S. RAPPLEYE,  
 WILLIAM A. DAYTON, F. M. DEFANDORF

*Committee on Membership*.....E. H. WALKER (chairman), M. S. ANDERSON, CLARENCE COT-  
 TAM, R. C. DUNCAN, JOHN FABER, G. T. FAUST, I. B. HANSEN, FRANK KRACEK, D. B.  
 JONES, E. G. REINHARD, REECE I. SALLER, LEO A. SHINN, F. A. SMITH, HEINZ SPECHT,  
 H. M. TRENT, ALFRED WEISSLER

*Committee on Meetings*.....H. W. WELLS (chairman), WM. R. CAMPBELL, W. R. CHAP-  
 LINE, D. J. DAVIS, H. G. DORSEY, O. W. TORRESON

*Committee on Monographs* (W. N. FENTON, chairman):  
 To January 1953.....R. W. IMLAY, P. W. OMAN  
 To January 1954.....S. F. BLAKE, F. C. KRACEK  
 To January 1955.....W. N. FENTON, ALAN STONE

*Committee on Awards for Scientific Achievement* (J. R. SWALLEN, general chairman):  
*For Biological Sciences*.....J. R. SWALLEN (chairman), L. M. HUTCHINS,  
 MARGARET PITTMAN, F. W. POOS, L. P. SCHULTZ

*For Engineering Sciences*.....R. C. DUNCAN (chairman), A. C. FIELDNER,  
 WAYNE C. HALL, J. W. MCBURNEY, O. S. READING, H. L. WHITTEMORE

*For Physical Sciences*.....L. A. WOOD (chairman), P. H. ABELSON,  
 F. S. DAFT, GEORGE W. IRVING, JR., J. H. McMILLEN

*For Teaching of Science*.....M. A. MASON (chairman), F. E. FOX, M. H. MARTIN

*Committee on Grants-in-aid for Research*.....L. E. YOCUM (chairman), H. N. EATON,  
 K. F. HERZFELD

### *Committee on Policy and Planning:*

To January 1953.....W. A. DAYTON (chairman), N. R. SMITH  
 To January 1954.....H. B. COLLINS, JR., W. W. RUBEY  
 To January 1955.....L. W. PARR, F. B. SILSBEE

*Committee on Encouragement of Science Talent* (A. T. MCPHERSON, chairman):  
 To January 1953.....A. H. CLARK, F. L. MOHLER  
 To January 1954.....J. M. CALDWELL, W. L. SCHMITT  
 To January 1955.....A. T. MCPHERSON, W. T. READ

*Representative on Council of A. A. A. S.*.....F. M. SETZLER

*Committee of Auditors*.....C. L. GAZIN (chairman), LOUISE M. RUSSELL, D. R. TATE

*Committee of Tellers*.....GEORGE P. WALTON (chairman), GEORGE H. COONS, C. L. GARNER

## CONTENTS

	Page
GEOLOGY.—The Murphree Valley anticline, Alabama. GEORGE W. STOSE.....	241
PALEONTOLOGY.—The arms of <i>Haerteocrinus</i> . HARRELL L. STRIMPLE.....	245
PALEONTOLOGY.—Designation of the type species of <i>Pseudochama</i> (additional note). DAVID NICOL.....	248
ENTOMOLOGY.—The ant larvae of the myrmicine tribe Crematogastrini. GEORGE C. WHEELER and JEANETTE WHEELER.....	248
ZOOLOGY.—Notes on the history and distribution of the reptiles. AUSTIN H. CLARK.....	262
ZOOLOGY.— <i>Poritextularia</i> , a new Recent foraminiferal genus. ALFRED R. LOEBLICH and HELEN TAPPAN.....	264
MALACOLOGY.—A new glycymerid from the Western Atlantic. DAVID NICOL.....	266
ICHTHYOLOGY.—Revision of the genus <i>Talismania</i> , with description of a new species from the Gulf of Mexico. A. E. PARR.....	268
PROCEEDINGS: THE ACADEMY.....	271
OBITUARY: Oscar Benwood Hunter.....	272

605.13  
.D2W23  
Vol. 42

SEPTEMBER 1952

No. 9

# JOURNAL

OF THE

# WASHINGTON ACADEMY OF SCIENCES

## BOARD OF EDITORS

WILLIAM F. FOSHAG  
U.S. NATIONAL MUSEUM

J. P. E. MORRISON  
U.S. NATIONAL MUSEUM

JOHN C. EWERS  
U.S. NATIONAL MUSEUM

## ASSOCIATE EDITORS

F. A. CHACE, JR.  
BIOLOGY

J. I. HOFFMAN  
CHEMISTRY

T. P. THAYER  
GEOLOGY

MIRIAM L. BOMHARD  
BOTANY

R. K. COOK  
PHYSICS AND MATHEMATICS

PHILIP DRUCKER  
ANTHROPOLOGY

C. W. SABROSKY  
ENTOMOLOGY

PUBLISHED MONTHLY

BY THE

WASHINGTON ACADEMY OF SCIENCES  
MOUNT ROYAL & GUILFORD AVES.  
BALTIMORE, MARYLAND



Entered as second class matter under the Act of August 24, 1912, at Baltimore, Md.  
Acceptance for mailing at a special rate of postage provided for in the Act of February 28, 1925.  
Authorized February 17, 1949

## Journal of the Washington Academy of Sciences

This JOURNAL, the official organ of the Washington Academy of Sciences, publishes: (1) Short original papers, written or communicated by members of the Academy; (2) proceedings and programs of meetings of the Academy and affiliated societies; (3) notes of events connected with the scientific life of Washington. The JOURNAL is issued monthly. Volumes correspond to calendar years.

*Manuscripts* may be sent to any member of the Board of Editors. It is urgently requested that contributors consult the latest numbers of the JOURNAL and conform their manuscripts to the usage found there as regards arrangement of title, subheads, synonymies, footnotes, tables, bibliography, legends for illustrations, and other matter. Manuscripts should be typewritten, double-spaced, on good paper. Footnotes should be numbered serially in pencil and submitted on a separate sheet. The editors do not assume responsibility for the ideas expressed by the author, nor can they undertake to correct other than obvious minor errors.

*Illustrations* in excess of the equivalent (in cost) of one full-page halftone are to be paid for by the author.

*Proof*.—In order to facilitate prompt publication one proof will generally be sent to authors in or near Washington. It is urged that manuscript be submitted in final form; the editors will exercise due care in seeing that copy is followed.

*Unusual cost* of foreign, mathematical, and tabular material, as well as alterations made in the proof by the author, may be charged to the author.

*Author's Reprints*.—Reprints will be furnished in accordance with the following schedule of prices (approximate):

Copies	4 pp.	8 pp.	12 pp.	16 pp.	20 pp.	Covers
100	\$3.25	\$6.50	\$ 9.75	\$13.00	\$16.25	\$3.00
200	6.50	13.00	19.50	26.00	32.50	6.00
300	9.75	19.50	29.25	39.00	48.75	9.00
400	13.00	26.00	39.00	52.00	65.00	12.00

*Subscriptions* or requests for the purchase of back numbers or volumes of the JOURNAL or the PROCEEDINGS should be sent to HARALD A. REHDER, Custodian and Subscription Manager of Publications, U. S. National Museum, Washington 25, D. C.

*Subscription Rates* for the JOURNAL.—Per year..... \$7.50

Price of back numbers and volumes:	Per Vol.	Per Number
Vol. 1 to vol. 10, incl.—not available*.....	—	—
Vol. 11 to vol. 15, incl. (21 numbers per vol.).....	\$10.00	\$0.70
Vol. 16 to vol. 22, incl. (21 numbers per vol.).....	8.00	0.60
Vol. 23 to current vol. (12 numbers per vol.).....	7.50	0.90

\* Limited number of complete sets of the JOURNAL (vol. 1 to vol. 41, incl.) available for sale to libraries at \$348.50.

MONOGRAPH No. 1, "The Parasitic Cuckoos of Africa," by Herbert Friedmann. \$4.50

PROCEEDINGS, vols. 1-13 (1899-1911) complete..... \$25.00  
 Single volumes, unbound..... 2.00  
 Single numbers..... .25

*Missing Numbers* will be replaced without charge provided that claim is made to the Treasurer within 30 days after of following issue.

*Remittances* should be made payable to "Washington Academy of Sciences" and addressed to the Treasurer, H. S. RAPPLEYE, 6712 Fourth Street, N.W., Washington 12, D.C.

*Exchanges*.—The Academy does not exchange its publications for those of other societies.

# JOURNAL

## OF THE

# WASHINGTON ACADEMY OF SCIENCES

VOLUME 42

September 1952

No. 9

ASTRONOMY. — *Meteors and meteorites.*<sup>1</sup> SYDNEY CHAPMAN, Queen's College, Oxford University, England. (Communicated by Richard B. Cook.)

When a shooting star or meteor darts with transient light across the night sky, children may think it is one of the stars of the pattern "come loose"; but the pattern remains as before. The stars of the pattern, which turns daily around the celestial poles, are immense blazing suns, millions of millions of miles away. The meteors are in our atmosphere, less than a hundred miles above the earth; and almost all of them are small, weighing a few pounds or less. When especially bright they are called fireballs. They enter our atmosphere from outside; a very few of them, called meteorites, penetrate to the ground, and provide our only substantial connection with extraterrestrial matter.

#### METEOR OBSERVATIONS

Among the watchers of the night sky, there have always been some who especially observe meteors, and leaders (like C. P. Olivier, of Philadelphia) who guide them and link them in societies and groups. Other countries, notably England, Russia, and India, also have such watchers.

Even a solitary meteor observer, without a telescope, can do effective work. He learns to know the pattern of the stars and notes where and when, on this background, a meteor appears and disappears, and its brightness—on a scale of magnitudes related to that used for the stars. If two observers, located many miles apart, have thus recorded the flight of a meteor, with sufficient accuracy, its speed, its heights of appearance and disappearance, and the location of its track can be calculated. But

only a very small minority of meteors are thus doubly recorded.

Meteors can also be photographed. Sometimes a photograph of part of the sky, taken with a telescope that follows the moving pattern, will show the trail of a meteor that has flashed across during the exposure. A *fixed* camera may record a meteor against a background of circular arcs traced on the plate by the stars of the moving pattern. In these cases the photographs do not indicate the time or location of the meteoric transit. If the same meteor is similarly photographed from a distance of 30 or more miles, the location of path, and the intrinsic brightness of the meteor, can be determined; but without visual timing the speed is not given, unless an occulting shutter on one of the cameras interrupts the exposure a few times each second.

Photographs generally show only very bright meteors, but with a telescope the eye can see meteors of the tenth magnitude or fainter.

#### THE NUMBERS OF METEORS

On an ordinary clear night a careful observer, without a telescope, will see a first-magnitude meteor about once in each 2-hour interval. He can observe all the bright ones in his field of view, but will miss most of the faint ones; only those near the center of his field of vision will be noticed. From any one place on an average about 50 shooting stars are visible each hour. It is estimated that about 2 million meteors, at least as bright as the first magnitude, fall daily upon the whole earth. Meteor watchers at least have the expectation of having something to record on every clear night. Fletcher Watson, of Harvard, has estimated that nearly

<sup>1</sup> Paper presented at the 21st Joseph Henry Lecture of the Philosophical Society of Washington, April 18, 1952.

a billion billion meteors fall daily upon the earth, down to a lower limit of brightness of magnitude 30—far beyond the range of detection by the world's greatest telescope; the existence of a lower limit of brightness is inferred on the basis that smaller objects must have been cleared from the solar system by the sun's radiation pressure.

#### RANDOM-METEORS AND SHOWER METEORS

Besides the isolated meteors that appear from random directions in any part of the sky, there are on some nights *showers* of meteors that are found to diverge from a particular small region of the star pattern, which is called the *radiant* of the shower. The divergence is an effect of perspective; the meteors of a shower really move along nearly parallel trails. Such showers are often called by the name of the constellation from which they radiate—for example, some of the principal showers, coming from the constellations Leo, Perseus, Orion, Gemini, are called the Leonids, Perseids, Orionids, Geminids.

The showers come at definite times each year, though not always with the same abundance; they may last one or more nights in succession. The principal showers are these:

Date of Maximum	Name	Average hourly number
January 3.....	Quadrantids	30-40
April 21.....	Lyrids	7-10
August 10-13.....	Perseids	40-60
October 20-23.....	Orionids	10-20
November 16-23.....	Leonids	10-15
December 11-13.....	Geminids	60

#### SUPERSHOWERS

At rare intervals, however, there are supershowers, when meteors rain copiously from the sky, attracting widespread attention. In former times they were often superstitiously regarded as portents of disaster.

There was a great supershower of Leonids in November 1833, when the hourly rate visible may have reached 35,000 at times. It was then that the divergence from a radiant was first recognized by D. Glusted and others. Afterward the American meteor astronomer H. A. Newton collected and discussed the original records of 13 earlier

November supershowers, one being as far back as A. D. 902. (The Chinese records of supershowers cover 24 centuries.) He found that they could be fitted to a cycle of recurrence of  $33\frac{1}{4}$  years and that when they appeared they did so in one of the last two or three years of each such cycle. In agreement with his prediction, Leonid supershowers recurred in November 1866, 1867, and 1868.

#### METEOR SWARMS

The *annual* recurrence of a meteor shower is ascribed to the existence of a cloud or swarm of meteor particles, moving along an orbit intersecting that of the earth. Each year, as the earth traverses the intersection, a meteor shower results if the swarm then extends along that part of its orbit. A periodic *supershower*, like that of the 1833 and 1866 Leonids, indicates that the swarm has a particularly dense part, and that the time of travel round the orbit equals the supershower period. The swarms are, however, very sparse; even at the peak of the 1833 Leonid supershower the meteors must have been about 20 km apart. In ordinary showers their mutual distances must be hundreds of kilometers.

Adams and Leverrier, the independent predictors of Neptune, were stimulated by the 1866 Leonids to calculate their orbit. The long period,  $33\frac{1}{4}$  years, shows that the swarm must travel many times farther from the sun than the earth; and as it comes at least as near to the sun as the earth, its orbit must be a very elongated ellipse, like that of the periodic comets.

#### METEORS AND COMETS

In 1867 Schiaparelli and Peters, astronomers of Italy and Germany, noticed that the calculated Leonid orbit agreed with that of a comet discovered in 1866, during its passage near the sun. Schiaparelli noticed also that the orbit of the August Perseid meteors agrees with that of another comet, discovered in 1862.

There are now at least six well-established cases of close agreement between orbits of comets and meteor swarms. One such comet, discovered by Biela, has a period of 6.6 years; its orbit was first computed in 1826.

By looking back in the records two earlier appearances were identified. It returned as expected in 1832, but not in 1839; in 1846 it reappeared and then divided into two parts, which gradually separated. They again appeared in 1852, but have not since been seen. However, three periods later, in 1872, when the earth crossed the orbit of the lost comets, there was a meteor supershower, repeated in 1885 after two more periods. This suggested that a meteor stream may result from the disruption of a comet; but this meteor stream, which is called either the Bielid or Andromedid (from its radiant in Andromeda), had given good showers at least seven times before 1872, one as early as 1741. The calculated position of the Biela comets in 1872 was far from the earth. The disruption of Biela's comet was not due to the action of any major planet—none was near it in the period concerned. There is no evidence that the breakup of a comet produces a meteor stream—two or more comets seem a more likely result.

The Leonids have been seen in October or November at least since A. D. 902, the Perseids in August for over 1,200 years, and the Lyrids in April for over 2,500 years; but the associated comets were first observed in the nineteenth century. The nature of the comet and meteor connections is at present mysterious.

In the past 120 years there have been six outstanding supershowers, all associated with cometary orbits; the Leonids in November 1833 and 1866, the Andromedids or Bielids in 1872 and 1885, and the October Draconids in 1933 and 1946. These are also called the Giacobinids because of their association with the Giacobini-Zinner comet; their period also is 6.6 years; the 1946 occurrence was predicted; it was very intense, though brief.

#### METEOR SPEEDS

When the orbit of a meteor swarm is known, its speed at each point is calculable; hence the meteor speed near the earth is known. The true direction from which they come is not that of their apparent radiant, which is determined by their motion relative to the earth, itself moving along its orbit with a speed of about 30 km per second.

There has been, and still is, some dispute as to the speeds of meteors, but any doubts can only refer to the random nonrecurrent meteors, for which no orbits are known. From visual observations it is difficult to determine the speed of a meteor accurately, and photographic measurements from cameras using a periodic occulting shutter are still few. The main question is whether meteors before falling into the atmosphere are members of the solar system, in which case their speeds relative to the sun, at the earth's distance from the sun, can not exceed 42.1 km per second; or whether they come from outside the solar system, along hyperbolic paths, with greater speed. Recently the radar observation of meteors has added much to our knowledge of meteor speeds and indicates that at least the great majority of meteors do not have hyperbolic speeds.

Relative to the earth, therefore, the speeds can range from 72 km/sec. (for meteors hitting the earth head on) to 12 km/sec. or less (for meteors overtaking the earth).

#### THE LIGHT FROM A METEOR

What happens when a tiny meteor particle, let us say as big as a pin's head, is swept up by the earth, or drawn down to it by attraction, or maybe overtakes the earth?

It comes into our atmosphere, generally along an inclined path. At first it travels in highly rarefied air but meets ever denser air as it descends. Its impact with the molecules of the air is very violent, owing to its great speed. To the meteor it seems as if the air molecules are rushing on to it with this speed. They slightly penetrate the surface of the meteor, and their great energy of relative motion is communicated to the particle in the form of heat. The surface layer is first melted, and then vaporized; the evaporated meteor atoms spread outward, with small speeds relative to the meteor, but they share its own great speed. Hence they collide violently with the air molecules they meet, mostly not in the direct path of the meteor itself. These collisions break off electrons from the air molecules and the meteor atoms, and also render the meteor atoms luminous; the molecules of the air are less easily ex-

cited to luminosity. Thus the meteor creates around itself, as it moves onward, a luminous cloud of its own atoms; this is what we see as a shooting star, a bright moving point. The cloud is continually blown away, and continually renewed by fresh evaporation until, in the case of small meteors, their substance is exhausted.

#### METEOR SPECTRA

The spectroscope is able to spread out this meteoric light into a band and reveal what kind of atoms or molecules are emitting the light. But the passage of a meteor is both rapid and unexpected, and their light is relatively faint, so that it is not easy to observe and photograph their spectrum. Only in recent years have detailed reliable results been obtained, notably by P. M. Millman, of Ottawa. They show that the meteoric light is emitted by *metallic atoms*—especially atoms of iron, calcium, magnesium, manganese, chromium, aluminum, nickel, and sodium. Despite much similarity between all his meteor spectra, Millman was able to distinguish two classes, in one of which the lines of ionized calcium are the most prominent feature, whereas in the other they are markedly absent.

All these metallic elements, except sodium, are (as far as we know) practically absent from the air itself. Hence it is inferred that they come from the meteor, and this is confirmed by the analysis of meteorites, namely, the meteors that are large enough to traverse the whole atmosphere and reach the ground. All these atoms are rather easily excited to luminescence by collisions. The light is quite different from that of comets, which show molecular bands in their spectra, and are rendered luminous not by collisions but by the ultraviolet light of the sun.

#### METEORIC IONIZATION OF THE ATMOSPHERE

As the tiny meteor moves onward surrounded by its small intensely luminous cloud of evaporated atoms, it leaves behind a long trail of electrons and ions, produced by the breakup of atoms and molecules—mostly atmospheric—through violent collisions with the meteor atoms. The electrons and ions recombine soon almost completely, usually in a second or less, but

during this time, though so brief, they diffuse outward, enlarging the diameter of the trail, and diminishing the number of electrons per unit volume, or, as we say, the ionization density. The trail will be many miles long, and initially less than an inch in diameter; it may rapidly be distorted by nonuniform winds, or by gusts and turbulence in the air, as we see happens with aeroplane trails at a much lower level.

#### RADAR OBSERVATION OF METEORS

The ionization trails of meteors have in recent years provided a new means of observing meteors, by radar beams. Free electrons, whether in a metal or a gas, respond readily to the electric alternating field of radio waves and scatter or reflect the waves. The presence of an ionized trail can be detected by a radar beam just as this can detect an airplane or a ship. The trail, during the brief time, usually a fraction of a second, in which its ionization is sufficiently intense, reflects back to their source those radio waves that meet the trail at right angles; waves meeting the trail obliquely are reflected away in other directions. The trail behaves, in fact, like a polished object in the dark, revealed by the glint of a narrow beam of light from an electric torch, from any spot where the beam meets the surface perpendicularly.

The time of passage of the radiowaves, to the trail and back to the receiver, is to be reckoned in microseconds; it gives the distance to the point of reflexion on the trail.

Such observations open a new chapter in meteoric astronomy. They are not hindered by clouds, so that weather need no longer hinder the meteor observer's night watch on the sky. And they are effective by day as well as by night, so that meteors can now be observed whether they fall on the night or the day hemisphere of the earth, although in the latter case their faint luminosity is hidden from us by the daylight glare of the blue sky. Already some important new meteor streams have thus been discovered, which would otherwise have been beyond our knowledge.

To get a sharp radio beam a large aerial is necessary; and to study meteors in different parts of the sky, the aerial must be



movable, like a telescope; this is a difficult instrumental problem, but is being successfully tackled.

Radio beams are more sensitive than the eye, and can detect meteors much fainter than the eye can see. Thus they extend the range as well as the accuracy of meteor observation, to meteors that are extremely small. A bright (first magnitude) meteor is probably less than a millimeter in diameter before entering the atmosphere; the faintest visible to the naked eye is less than a hundredth of an inch.

The beams detect the trail more easily than the meteor itself, but radio methods of determining the speed of the meteor have been developed by C. D. Elyett and J. G. Davies.

#### METEOR HEIGHTS

The height of appearance and disappearance of a meteor depends on its mass and its speed and also on the vertical distribution of air density in the atmosphere. The smaller meteors disappear at greater heights than the larger meteors, because they are more rapidly evaporated away. There is naturally a range of heights of appearance and disappearance, corresponding to differences of mass, speed, and inclination of the meteors. The heights of appearance range from about 80 to 110 km, with a maximum frequency at about 100 km. But the curve of distribution of the heights of disappearance does not show the simple form that might be expected, but shows two maxima, at about 85 and 95 km, with a minimum in between. In 1922 this was interpreted by F. A. Lindemann and G. M. B. Dobson as indicating that the air at about 60 km height is hotter than that in the lower part of the stratosphere; the basis of the interpretation was a theory of meteor luminosity in the atmosphere. The argument has since had to be revised somewhat, but the conclusion has been confirmed in other ways, most recently by rocket measurements.

#### METEORS AND UPPER ATMOSPHERIC INVESTIGATION

The investigation of the temperature distribution in the upper atmosphere by means of meteors, begun by Lindemann and Dob-

son, has been energetically and fruitfully pursued in recent years by the Harvard Observatory and its substations, under the guidance of F. L. Whipple. These studies, like those by means of rockets, are very difficult, and the problems are not yet solved.

Meteors can give other interesting information about the upper atmosphere; occasionally a meteor leaves a *luminous* trail behind it, which may last for seconds, minutes, or even, very rarely, an hour or more. Almost always the trail soon becomes distorted, in a way that shows how far from static is the air at those high levels. The changes of shape indicate nonuniform winds, which may be due to differences of wind at the different heights through which the meteor descends, usually obliquely. In the lower atmosphere such height differences are often made manifest by the different drifts of clouds at different levels. C. P. Olivier has given valuable summaries of the cases of long-enduring meteor trails.

The longest lasting trail known to me is one that appeared on February 22, 1909, and stretched across the English Channel from England to France; the data were very fully discussed by J. E. Clark. The trail was 150 miles long and sloped downward from 55 to 49 miles in height. It remained visible for 1 $\frac{3}{4}$  hours. One end rapidly became contorted and dispersed to invisibility, showing strong local turbulence; the rest became greatly bent and curved, revealing winds of speed up to nearly 200 miles an hour, in different directions at different levels.

Many attempts have been made to determine the winds at considerable (though lower) heights by ejecting puffs of smoke from guns or rockets; but it has proved difficult to eject enough smoke to remain visible during the time needed to determine the wind from the drift. Meteors sometimes fulfill the desired purpose for us, at higher levels, but at times and places beyond our control and prediction. Usually these long lasting trails are not observed reliably from different places, as required for the interpretation of their motion in terms of wind. Another observation hitherto lacking for these trails is their spectrum, which would perhaps tell us how a trail can remain luminous for so long. At present this is a mystery.

However, meteors without long-lasting luminous trails can now tell us something about the wind at high levels, by a new radio technique devised by L. V. Manning and O. G. Villard at Stanford. They determine the small change of frequency of the waves reflected by the ionized meteor trail; this is a Doppler effect like the change of pitch of a railway whistle when the train is approaching or receding. It gives the component of the wind along the direction of the radio beam, that is, at right angles to the trail.

#### METEORITES

The shooting stars so far discussed are those of ordinary brightness, excluding the very bright ones called fireballs; these are larger bodies than the ordinary shooting star, which disappears while still at a great height in the atmosphere, because it becomes completely evaporated.

A much bigger meteor will, like a small one, be heated on the outside by the impact of the air; until it has descended to a height of about 25 miles, its surface layer will be continuously melted and vaporized, but the successive layers removed will form only a small fraction of the whole, and the interior may remain almost at its initial temperature. When it gets to a level where the length of the free paths of the air particles, between collisions, is comparable with the size of the meteor, the interaction with the air changes its character. Instead of the air particles directly striking the meteorite and penetrating it, a cap of compressed air forms in front of it, and a shock wave is set up, as when a bullet flies through the air at a speed greater than that of sound. Less heat is given to the meteorite, whose surface may still be hot enough to be melted, but not to be vaporized. As the meteorite descends to denser air, the molten layer may be blown off in droplets, perhaps seen as a shower of bright sparks scattered along its track. The next layer will then be melted, but below a certain height, as the meteorite gets slowed down, the heat and luminosity may decline, so that the meteorite ceases to shine. Sometimes near the end of its visible track it may break up with a loud detonation, perhaps due to its being in rapid rotation, if its form is irregular. In the last, invisible,

part of its track a fireball may be slowed almost to its terminal speed, depending on its shape, size, and weight—a speed maybe comparable to that of sound but far inferior to its initial speed.

Nevertheless this speed may be great enough for the meteorite to bury itself some feet below the ground, leaving a tubular hole behind it.

Meteorites are indeed stones from the sky, and provide our only opportunity, as yet, of directly handling and examining matter not originally part of the earth. Indirectly, of course, astronomers during the past century have been very successful in finding the nature and chemical composition of the celestial bodies by means of the spectroscope.

#### METEORITES IN THE PAST

In old times, when men readily believed in miracles, the fall of a stone from the sky was easily accepted as a sign from heaven, and if found, it might be regarded as sacred. The image of the goddess Diana of the Ephesians, mentioned in the Acts of the Apostles, where it is said to have fallen from the sky, may have been a meteorite. In Mecca, the Moslem's holy city, there is a sacred black stone in the Kaaba shrine, which from the descriptions of it may well be a meteorite.

A more skeptical temper prevailed in the age of Voltaire and the French Revolution; the learned scientists of the French Academy were not minded to believe in miracles, and they dismissed stories of stones falling from the sky, as fabulous inventions of ignorant people. In 1803 very circumstantial stories reached Paris of a great fall of thousands of stones from the sky at L'Aigle, in Normandy. To put these foolish tales to rest, the Academy charged a distinguished member, Biot, a physicist, to investigate the stories, expecting him to report that they were baseless.

However, Biot listened to the local stories, examined the stones said to have fallen, and reported that they had indeed done so.

#### FREQUENCY OF METEORITE FALLS

The fall of a sizable meteorite is a rather rare event in any country. Estimates must

be uncertain but have suggested that five or six fall daily on the whole earth, or less than 2,000 a year; and that the average meteorite weighs about 200 pounds before entering the atmosphere but is reduced to about 50 pounds before reaching the ground, by evaporation, successive blowing off of the molten surface layer at lower levels, and breakage. The estimates of the total mass of meteoritic matter annually falling upon the earth vary widely, and range up to more than a million tons, but most of this is in the form of meteoritic dust. The greater part falls into the sea, and claims have been made that meteoritic nickel has been identified in deep sea sediments. Even the highest estimates signify only a negligible accretion of meteoric mass to the earth during its reputed lifetime of the order of a few billion years.

Very few even of the sizable falls are likely to be observed; they descend unseen into the sea or, on land, in lonely and desolate places or among snowy wastes; and many even of those that fall in inhabited countries will fall by day, or from cloudy night skies, and escape notice. Sounds may sometimes be heard, or a fireball seen, or slight tremors may be felt, set up by the impact with the ground; but still the actual fall may not be noticed, or if observed, the stone may not be found.

Meteorites can be grouped in two broad classes, called stony meteorites and iron meteorites. Among meteorites found after being seen to fall, there are more than ten of the stony to one of the iron kind; but in museums, the iron meteorites outnumber the stony ones sixfold. The discrepancy is easily explained: the iron meteorites are much more distinctive, less like terrestrial stones, than the stony ones, especially after weathering has set in. Hence they are often recognizable as meteorites although not seen to fall, whereas the great majority of stony meteorites that fall unseen have remained unrecognized.

#### METEORITIC FINDS

One record states that up to 1927 the number of falls that were seen, and followed by finds, was 505 (the finds were in some cases made weeks later); and the number of finds

not seen to fall was given as 474. These numbers, doubtless incomplete, total nearly 1,000; they refer to *occasions* of falls and finds, whether one stone or many fall at the same time. Some falls yielded thousands of stones, and specimens of them are distributed in museums throughout the world. An outstanding case occurred at Pultusk in Poland in 1868, when perhaps 100,000 stony meteorites fell. Other notable cases occurred at Holbrook in Arizona in 1912, when 14,000 stony meteorites fell; at L'Aigle in Normandy in 1803 (already mentioned), 2,000 to 3,000; and at Stannern in Moravia, 1808, 200 to 300.

The specimens in museums include some recorded falls, mostly modern; the others are the gleanings of millennia.

There is an immense literature on the finding of meteorites and supposed meteorites. Both kinds, iron and stony, are easily distinguishable from any terrestrial stones when carefully examined and still more clearly so when cut across to expose their internal structure. Some big masses fallen ages ago and still on the surface, or partly exposed, or incidentally uncovered, have been recognized by geologists, explorers, and others. Smaller ones have been turned up by the plow, and being noted as unusual have come to be identified by experts.

No meteorites appear to have been found in coal beds or rock quarries. The deepest found was in gold-bearing alluvium, 31 feet down.

#### VERY BIG METEORITES

The biggest known piece of a meteorite seen to fall weighed 820 pounds, and other pieces were found, from 80 pounds downward; this fell in Arkansas on February 17, 1930. At a height of 10 miles it was seen to break into three pieces; all were lost to view at 5 miles height. The big piece was found 3 weeks later in clay soil; it had made a hole more than 8 feet deep and had scattered clay for 50 yards around. Later a smaller piece was found 2 miles away. All were stony, not iron.

The pieces from some exploded meteorites may be scattered over 100 or more square miles.

The previous biggest meteorite seen to

fall was a stone of 650 pounds in Czechoslovakia, in 1866.

The biggest known meteorites were not seen to fall and may have fallen long ago. The weights range from over 35 tons downward; the biggest is the South African Hoba meteorite, then comes one from Greenland, then a 15- or 20-ton stone at Sinaloa in west Mexico. When Sir John Ross, about 1820, first brought news of the Eskimos of the Cape York region, Greenland, he recorded that they were using meteoritic iron for knife blades, harpoon heads, and other implements. Peary visited the region (Melville Bay) in 1894 and found two large and one smaller iron meteorites, all of which he brought, in two voyages, to New York. The biggest, now in the Hayden Planetarium, New York, is said to measure 12 by 8 by 6 feet and to look like polished steel. The main constituents are iron, 92 percent, and nickel, nearly 8 percent.

#### THE COMPOSITION OF METEORITES

No terrestrial rocks have such a composition. The stony meteorites also, many of which contain up to 20 or 25 percent of iron (partly metallic, partly oxidized), differ in several respects from terrestrial stones; they may contain also about 20 percent of magnesium oxide; the average silicate content is less than 40 percent, as compared with about 60 percent in terrestrial igneous rocks.

Besides these substances, meteorites, both iron and stony, contain several other elements, pure or oxidized, numbering more than 40 in all. They include for example aluminum, calcium, chromium, manganese, and sodium, already mentioned as contributing to the spectrum of meteors; others such as carbon and hydrogen, though present in meteorites, have not been recorded in meteor spectra. The carbon is sometimes crystalline, like small diamonds, sometimes amorphous like graphite. Some stony meteorites are very hard and will cut glass.

Naturally there are transitional types of meteorites between the stony and the iron, and there is evidence for some exceptional types, one of them being glassy; two cases in which copper, metallic or in combination,

was conspicuously present, have lately been discussed by H. H. Nininger and F. A. Paneth.

#### THE STRUCTURE OF METEORITES

The internal structure of meteorites is very remarkable. The cut surface of an iron meteorite, when etched with acid, shows crystalline markings (known as Widmanstätten figures). Mingled in the iron there are often many crystalline particles of the mineral named olivine, which also occurs on the earth. Stony meteorites contain much olivine, mingled with bits of iron, sometimes apparently introduced therein after the olivine has been shattered. All known meteorites appear to be igneous; that is, heat has played a large part in their evolution, as contrasted with the sedimentary rocks we know, slowly built up by deposition of small particles, water (or air) borne. How meteorites have been formed is still a mystery, and a subject for discussion and controversy. They appear to have undergone repeated disruption and conglomeration, and heating and cooling. Many of them contain remarkable rounded granules called chondrules.

#### THE RADIOACTIVITY OF METEORITES

The radioactivity and helium content of meteorites has been much studied, in order to infer their age, or the ages of different parts of their conglomerate structure. Iron meteorites, and also some stony meteorites, are able to retain most of the helium resulting from the decomposition of their uranium and thorium. F. A. Paneth, examining separately the metallic and silicate parts of a meteorite that fell at Beddgelert in Wales on September 21, 1949, inferred that the silicate seems to have solidified more than 1,000 million years ago and the metallic part about 200 million years ago (these are preliminary estimates). The ages found for meteorites range very widely, from billions of years down to a million years. Clearly these stones from the sky enshrine much cosmic history which we may hope can gradually be unfolded.

#### METEORIC SOUNDS AND APPEARANCES

If a meteor no bigger than a pin's head can produce a bright shooting star, meteor-

ites large enough to reach the ground, in one or more sizable pieces, may be expected to be much more conspicuous in their falls. Even the Beddgelert meteorite just mentioned, that weighed a little under 2 pounds, though probably only part of a larger body, was reported as making a noise like an express train or fast airplane. Many meteorites break up with great explosive sounds. Intense brightness, of different colours (in different cases), is a common feature, though in the few cases of visible daylight meteors the light is relatively dimmed; in such cases a smoky trail may be left after the passage of the meteorite.

#### LEGAL AND FINANCIAL ASPECTS

The Beddgelert meteorite was found on the top floor of a hotel, having cleanly penetrated the roof. To whom does a meteorite belong that falls thus in a building or on private land? The law differs from country to country, and in England the question has never been determined; the Beddgelert meteorite was only the ninth meteorite seen to fall, and then found, in the history of England and Wales. In this and earlier cases the stone was disposed of by agreement; the Beddgelert hotel keeper sold the stone to the British Museum and the University of Durham jointly; his landlords, a public company, laid no claim to it.

Meteorites may raise legal and financial problems in other ways; for example, was the insurance company liable to pay for the damage caused to the roof? There is no space here to enlarge on these matters, except to say that from scientists and museums there is a considerable demand for meteorites, which may command up to 500 or even 1,000 dollars per pound.

Damage to property and persons by meteorites is rare. The nineteenth-century French astronomer Flammarion said in one of his books (1872) that meteorites had caused 14 fatalities but did not cite his authorities. In 1906 there were newspaper reports of a Mexican sheep herder in Texas being killed by a meteorite, but I do not know whether the report was true.

#### METEOR CRATERS

Now I come to the last phase of this cursory survey of a wide-ranging subject—

the hole made by a great meteorite when it meets the ground.

The deepest *tubular* hole found was about 8 feet long; usually it is less. One of the many fragments of a meteorite that fell in Rhodesia on October 5, 1950, broke a log in two and buried itself 4 feet down.

There is, however, a quite different kind of hole made by meteorites of the greatest mass and momentum, which remain unbroken during their flight, or, if broken, not too dispersed. Holes of this second kind are called craters; they might well form the subject of a whole lecture, and more.

Fourteen crater regions are now known, counting only craters of 100 feet diameter or more; in some regions the craters are not single but in groups of 20, 50, or even more.

The most famous crater is that of Arizona, near Flagstaff. Alaska has one on Amak Island, discovered in 1942. The United States has yet a third crater, in Texas. Australia has four known craters or groups of craters, Canada one, Argentine one, Africa one, Europe one, Arabia one, and Siberia two. Most of the craters are prehistoric, but those of Siberia were formed in living memory in 1908 and 1947.

The conversion of the immense kinetic energy of the meteorites in these cases must involve enormous generation of heat and explosive force, but seems not to cause deep penetration.

I will close with a brief account of the greater of the Siberian falls, of 1908. It occurred in a desolate region consisting of wooded shallow swamps overlying permafrost. An observer at a distance saw in the early morning hours of June 30 a fiery body rising from the southern horizon, like a small sun, which hurried northward. Less than a minute later the ground around him suddenly rose and fell again—a harmless earthquake shock. Then a pillar of fire mounted up in the sky, and at once three or four distinct blows of incomparable force and quality were heard, followed by a roar and rumbling. This was audible over an area more than 600 miles in radius. River waters rose in big waves, animals were blown off their feet, many buildings were damaged; all this was far away from the fall. An atmos-

pheric wave was set up that traveled twice round the globe.

At dusk the same day enormous silver clouds were seen, at more than 50 miles height; they scattered the light of the sun after sunset, and almost turned night into day over much of Siberia. Some days later there were several remarkably light nights over England, whither some of the high dust had drifted. Their cause, and that of the barometric disturbances, was not discovered till many years had elapsed.

Near the impact two villages disappeared, and all the trees were overturned within a radius of many miles. They were so seen when Russian scientists first visited the place 18 years later. But in the center of the

region there was no great crater like that of Arizona, which is nearly a mile across. There were also many large water-filled holes, the biggest of them 150 feet across.

#### GENERAL REFERENCES

- OLIVIER, C. P. *Meteors*. Baltimore, 1925.  
 WATSON, F. C. *Between the planets*. London, 1947.  
 NININGER, H. H. *Meteorites*. 1951.  
 Also recent papers in Monthly Notices of Royal Astronomical Society, Philosophical Magazine, Geochimica et Cosmochemica Acta, Proceedings of the Institution of Radio Engineers, Journal of Geophysical Research, and Journal of Atmospheric and Terrestrial Physics.; also, for meteorites, in Geological Magazine, American Mineralogist, and other geological periodicals.

**BOTANY.**—*A new Guzmania from Colombia*. LYMAN B. SMITH, Department of Botany, U. S. National Museum.

The following species of bromeliad is one of a large number of novelties discovered in Colombia by Mulford B. Foster. Its separate treatment here is made necessary by its presence in another collection which is due to be reported sooner than the remaining Foster novelties.

***Guzmania geniculata*** L. B. Smith, sp. nov.

Fig. 1

Verisimiliter acaulis; laminis foliorum ligulatis, subglabris; scapo erecto; scapi bracteis imbricatis; inflorescentia bipinnata, basi laxa; axi geniculato; bracteis primariis spicas inferiores sub-

aequantibus; bracteis florigeris quam sepalis paulo brevioribus, laevibus; sepalis breviter connatis.

Probably stemless, the flowering plant 8 dm high; leaves 7 dm long, the sheaths about 1 dm long, dark castaneous at the base, purple-striped above, appressed-lepidote, the blades ligulate, acute, 4 cm wide or more, very obscurely lepidote, green; scape erect, stout; scape-bracts strict, imbricate, the lower foliaceous, the upper ovate, acute; inflorescence cylindrical, bipinnate, lax below, dense near the apex; axis geniculate, stout, dark castaneous in age; primary bracts ovate, acute, the lower ones about equaling the spikes, the upper much shorter; spikes divergent, dense, subglobose, 3 cm long, the stipe stout, flattened,

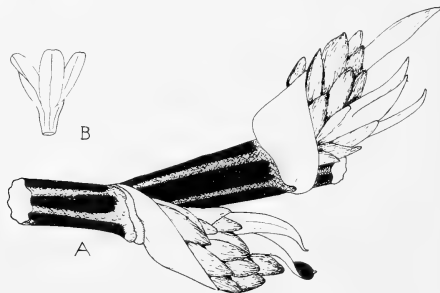

FIG. 1.—*Guzmania geniculata*: a, Section of the inflorescence  $\times 1$ ; b, sepals  $\times 1$ .

5-10 mm long; floral bracts broadly ovate, rounded with a thick apical cusp, slightly shorter than the sepals, coriaceous, even, glabrous, castaneous in age; flowers subsessile; sepals elliptic, 13 mm long, connate for 3 mm, nerved; petals and stamens unknown.

Type in the Gray Herbarium, collected on

trees, above Sibundoy, Territory of Putumayo, Colombia, altitude 2,280 meters, October 28, 1946, by M. B. and R. Foster (no. 1972).

Its stout geniculate floral axis distinguishes *Guzmania geniculata* from the group of species around *G. sphaeroidea* (André) André ex Mez where it shows its closest affinity.

ENTOMOLOGY.—A review of the genus *Tegenaria* in North America (Arachnida: Agelenidae).<sup>1</sup> VINCENT D. ROTH, Oregon State College. (Communicated by C. W. Sabrosky.)

This review is not intended to be a complete taxonomic discussion of the Nearctic *Tegenaria* but aims to clarify the position of the many names used in this genus. The area under consideration is that part of North America north of and including Mexico. This study was stimulated by Roewer's *Katalog der Araneae*, in which he lists 16 species of *Tegenaria* from the Nearctic region. Since its publication, one more species has been added. Of the total, five are recognized as valid, three are questionable species, one probably does not belong to the Agelenidae, four are placed in synonymy, and four are true calymmarids.

Keys and notes are furnished for the separation of the recognized species, and the remaining species are discussed briefly. The female epigynum for two of the species is illustrated for the first time.

The species of North American *Tegenaria* are identified by the following characteristics: size moderate to long, varying from 6 to 17 mm in length; color usually tan to

brown with darker markings; integument of carapace, legs, and abdomen densely to sparsely covered with white to brown plumose hair; carapace similar in shape to other Ageleneae, pars cephalica narrowed to about one-half the width of the pars thoracica; eyes similar in size; chelicerae slightly to strongly geniculate, promargin bears 3 to 6 teeth, the retromargin 3 to 6 teeth and none to 2 or 3 denticles; legs moderately long with scattered spines; spinnerets subapical in position; anterior and posterior spinnerets widely separated, the latter situated laterally and slightly dorsally to the median spinnerets; distal segment of the anterior spinnerets small, hemispherically shaped; median spinnerets almost as long as anterior spinnerets; basal segment of posterior spinnerets as long as anterior spinnerets, distal segment as long as the basal segment, slender and tapering distally. The following key will separate the *Tegenaria* from other North American Agelenidae:

<sup>1</sup> Published with the approval of the Oregon State Monographs Publication Committee. Research Paper 201, School of Science, Department of Entomology. Supported in part by a grant from the Oregon Academy of Science.

Unless otherwise indicated all specimens have been collected by and are in the collection of the author. Abbreviations used with distributional records are: USNM, United States National Museum; AM, American Museum of Natural History; CAS, California Academy of Sciences; and HEF, the collection of Mrs. D. L. (Harriet Exline) Frizzell, of Rolla, Mo.

The author expresses his thanks to Dr. W. J. Gertsch, of the American Museum of Natural History, Dr. E. A. Chapin and Dr. W. D. Field, of the U. S. National Museum, and Mrs. Frizzell, all of whom generously supplied material and information. In addition many thanks are extended to Miss E. B. Bryant, of the Museum of Comparative Zoology, and E. Browning, of the British Museum (Natural History), for information concerning certain types.

- 1. Plumose hair present on carapace, abdomen, and legs (visible with 30-100 X magnification). (The hairs are often scarce on specimens that have been shaken about in alcohol for many years.)..... (AGELENEAE)..... 2
- Plumose hair absent on carapace and abdomen; hair either setose or barbed (*Cybaeota*)  
 other AGELENEAE
- 2. Anterior eye row almost straight; anterior median eyes located between the anterior lateral eyes..... *Tegenaria*
- Anterior eye row strongly procurved; anterior median eyes located, more or less, between the posterior lateral eyes..... other AGELENEAE

The following key to the species of North American *Tegenaria* is adaptable to both immature and adult spiders:

- 1. Promargin of chelicera with 3 teeth..... 2
- Promargin of chelicera with 4 to 6 teeth, oc-

- casionally 3 on one side but never on both sides.....4
- 2. Retromargin with 3 or 4 teeth and no denticles (cosmopolitan).....*domestica* (Clerck) Retromargin with 4 to 6 teeth and 2 or 3 denticles.....3
- 3. Sternum with 3 or occasionally 2 pairs of distinct, round, light spots laterally; conductor of male palpus ending with a single spur; epigynum bearing 2 broad lateral spurs (Pacific Northwest).  
*gigantea* Chamberlin and Ivie <fl. Sternum usually lacking paired light round spots, if present, indistinct; conductor of male palpus terminated by 2 long pointed teeth; epigynum lacking lateral spurs (Pacific Northwest, Europe).  
*agrestis* (Walckenaer) <fe
- 4. Sternum with two pair of light round spots laterally and a median mark which is tridentate posteriorly (southern U. S. from California to Alabama).....*antrias* Crosby Sternum lacking paired, light round spots (southern Mexico) *flexuosa* O. P. Cambridge

**Tegenaria antrias** Crosby

*Tegenaria antrias* Crosby, 1926: 2, fig. 3 (♀).  
*Tegenaria simplex* Bryant, 1936: 90, fig. 9 (♀) (n. syn.).  
*Tegenaria castro* Chamberlin and Ivie, 1942: 21, figs. 27-29 (♂♀) (n. syn.).

The author has had on hand males and females from the type localities of *T. antrias* Crosby and *T. simplex* Bryant, and a female from the type locality of *T. castro* Chamberlin and Ivie. There are no significant differences in structure or color, only the minor variations one finds in long series. Miss Bryant graciously compared the type of *T. simplex* Bryant with specimens from the three type localities and declared them identical.

Color: Sternum dusky with a median light band, trifurcate on the posterior half. Anterior portion flanked by two light spots on either side. Legs with dusky annulations, darkest on legs IV, becoming lighter on the anterior legs, indistinct on legs I.

Chelicera: Promargin armed with 4 teeth, occasionally 3 or 5 on one side. Retromargin with 3 to 5 teeth, the mesal two teeth often fused at base.

Size: Males (7) range in size from 5.5 to 10.1 mm, averaging 7.5 mm; females (15) 5.3 to 10 mm, averaging 7.2 mm.

Distribution: Southern United States from Alabama to California and north to Sacramento, Calif. It is also probably present in northern Mexico. NEW MEXICO: Carlsbad Caves, 1941, no other data (♂♀), USNM; CALIFORNIA: Sacramento, May 27, 1918, H. Van Duzee (2♀), CAS; San Francisco, R. F. Sternitsky (3♀), AM; Castro Valley, Alameda County, Sept. 16, 1938, W. M. Pearce (3♀), AM; Nov. 11, 1938, W. M. Pearce (♀), Feb. 26, 1939, W. M. Pearce (imm.), AM; TEXAS: 3-4 miles west of Dallas, 1935-37, Ottys Sanders (♀), AM; Austin, Nov. 25, 1945, D. L. and H. E. Frizzell (2♂, 7♀), HEF, April 27, 1946, D. L. and H. E. Frizzell (3♀), HEF; ALABAMA: Mobile, 1941, Archer (♂♀), AM. In addition one specimen (♀) labeled "Altoona, Pennsylvania" is in the collection at the United States National Museum. This is undoubtedly mislabeled.

Type locality: Female type of *Tegenaria antrias* Crosby from Carlsbad Caves, N. Mex. This type is supposedly deposited in the United States National Museum, but the author was unable to locate it during a visit in the summer of 1950. Female holotype of *T. simplex* Bryant from Dallas, Tex., is deposited in the Museum of

RECOGNIZED NORTH AMERICAN SPECIES OF  
TEGENARIA

**Tegenaria agrestis** (Walckenaer)

*Aranea agrestis* Walckenaer, 1802: 216 (♂♀).  
*Tegenaria magnacava* Exline, 1936: 23, fig. 5 (♀).  
*Tegenaria magnacava* Exline, Chamberlin and Ivie, 1937: 213 (synonymy suggested at this time).  
*Tegenaria agrestis* Walckenaer, Exline 1951: 308-310, figs. 1-5 (♂♀).  
For complete synonymy and references consult Roewer, 1944: 24.

Color: Sternum yellowish orange, with two dusky markings extending from the lateral edges of the labium, posteriorly to opposite the third coxae where the lines fade out. On immature specimens the dusky markings are darker, outlining three pairs of light, round spots laterally and a median light line. Legs lack dusky annulations.

Chelicera: Promargin armed with 3 teeth; retromargin bearing 4 or 5 teeth and 2 or 3 denticles.

Size: Males (2) 9.5 and 10.3 mm; female (1) 12.7 mm.

Distribution: Europe. Seattle, Wash. OREGON: Corvallis, Aug. 29, 1947 (♂♀), May 18, 1949 (imm.), April 16, 1951 (imm.).

Type locality: The female holotype of *T. magnacava* Exline from Seattle, Wash., has been placed in the Museum of Comparative Zoology at Harvard University. The type locality of *T. agrestis* Walckenaer was probably France. The original description was not available to author.



Comparative Zoology at Harvard University. The female holotype of *T. castro* Chamberlin and Ivie from Castro Valley, Alameda County, Calif., male allotype from Lindsay, Okla., both in the University of Utah collection.

***Tegenaria domestica* (Clerck)**

*Araneus domesticus* Clerck, 1757: 76, fig. 9 (♀).

*Tegenaria detestabilis* O. P. Cambridge, 1877: 275 (♀) (n. syn.).

*T. derhami* Scopoli, Exline, 1938: 24-25, figs. 25-26 (♂♀).

*T. derhamii* Scopoli, Kaston, 1948: 279-280, figs. 895-899, 2053-2055 (♂♀).

For complete synonymy and references consult Roewer, 1944: 31.

*T. detestabilis* O. P. Cambridge was described from one female which, "had been damaged by an attempt at preservation in turpentine, whereby the eyes were concealed . . . For the same reason the exact form of the genital aperture was scarcely plain." At the request of the author, E. Browning, of the British Museum, graciously cleaned the type and forwarded an exceptionally clear illustration of the external epigynum which compares favorably with that of *T. domestica* (Clerck).

Color: Sternum varies from a yellowish brown with no markings to a dark brown with a pale

median line flanked with two or three pale spots. Legs variable, usually with dusky annulations, occasionally without.

Chelicera: Promargin armed with 3 teeth, retromargin usually armed with 4 teeth, occasionally 3.

Size: Males (9) range in size from 6.1 to 8.5 mm, averaging 6.84 mm; females (11) 6.3 to 8.9 mm, averaging 7.53 mm.

Distribution: Cosmopolitan. In the area considered in this paper, *T. domestica* (Clerck) has been collected from northern Canada (lat. 79° N., long. 74° W. on the east coast of Ellesmere Island, the type locality of *T. detestabilis* O. P. Cambridge) to southern Mexico (Uruapan, Michoacán, September 17, 1943, M. Cárdenas (♂), AM) and from the Pacific to the Atlantic coasts.

***Tegenaria flexuosa* F. O. Pickard-Cambridge**

Figs. 1, 2

*Tegenaria flexuosa* F. O. Pickard-Cambridge, 1897-1905: 334, figs. 34-34a. (♂).

*T. flexuosa* F. O. Pickard-Cambridge was described from a single male and two immature females from Omilteme in Guerrero, Mexico. Several mature females from southern Mexico were studied for the present review.

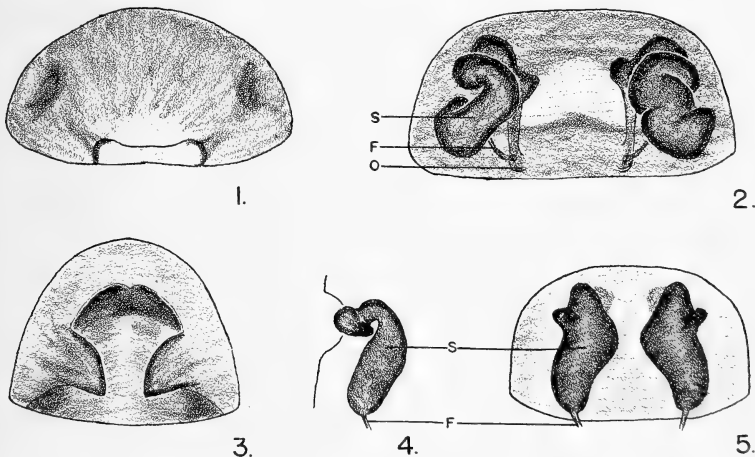

FIGS. 1, 2.—*Tegenaria flexuosa* F. O. Pickard-Cambridge: 1, Female epigynum, ventral view; 2, female epigynum (cleared) dorsal view. (S, spermatheca; F, fertilization duct; O, opening of the epigynum.)

FIGS. 3-5.—*Tegenaria gigantea* Chamberlin and Ivie: 3, Female epigynum, ventral view; 4, lateral view of spermatheca; 5, female epigynum (cleared), dorsal view. (S, spermatheca; F, fertilization duct.)

Color: Sternum dark brown with a light-brown rectangular mark extending from the base of the labium to the middle of the sternum where it narrows to form a slender, light mark to the posterior edge. Median mark absent in the lighter colored specimens. Legs with dusky annulations which become lighter distally. They are darkest on the first pair of legs, becoming successively lighter on the posterior pairs.

Chelicera: Promargin of chelicera armed with 4 teeth, retromargin armed with 5 or 6 teeth and 2 or 3 denticles.

Epigynum: The external epigynum is quite simple and lacks heavy sclerotization as is usually present in *Tegenaria*. The most evident structure is a transverse subrectangular median sclerite, in front of which is a whitish, membranous area. Barely visible through the integument are parts of the spermathecae lying at a 45° angle from the lateral anterior edges of the median sclerite.

The internal epigynum consists of two separate halves. One side is herewith described. The transparent connecting canal arises along the lateral edge of the median sclerite and extends dorsally to the spermatheca. The latter consists of a heavily sclerotized tube, strongly twisted, and folded back upon itself at two points as illustrated in figure 2. A slender fertilization duct arises posteriorly along the mesal edge of the spermatheca and curves dorsally.

Size: Male (type) 7 mm; females (3) range in size from 7 to 9.8 mm.

Distribution: All recorded specimens and specimens seen by the author have been collected within a 180-mile radius from Mexico City, Mexico. MORELOS, Cuernavaca, Sept. 1941, H. Wagner (♀), AM; SAN LUIS POTOSÍ, Tamazunchale, July 6-7, 1941, L. I. Davis (♀), AM; MÉXICO, Tenancingo, Sept. 27-Oct. 7, 1946, H. Wagner (♀); GUERRERO, Parque Humboldt near Taxco, 2,500 m., Dec. 26, 1943, C. Bolívar, C. Tellez (imm.), AM; FEDERAL DISTRICT, Desierto de los Leones, Mar. 12, 1944, M. Cárdenas (imm.) AM.

Type locality: A male type and two immature females were collected at Omilteme, Guerrero, in Mexico and are deposited in the collection of F. D. Godman and O. Salvin at the British Museum.

***Tegenaria gigantea* Chamberlin and Ivie**

Figs. 3-5

*Tegenaria gigantea* Chamberlin and Ivie, 1935: 31, fig. 106 (♂).

*T. gigantea* Chamberlin and Ivie, Exline, 1936: 21, fig. 3 (♂).

*T. gigantea* Chamberlin and Ivie, Exline, 1938: 25, figs. 30-31 (♂).

Color: Sternum dark brown with a pale median stripe arising at base of labium, expanding slightly and then narrowing posteriorly. Three pale spots lie laterally to the median line. Occasionally the posterior spot nearly connects with the median line forming a tridentate mark. Legs lack annulations. Male femur in this species often a very dark brown, contrasting with the yellowish brown of the other legs.

Chelicera: Promargin armed with 3 teeth; retromargin teeth variable, usually 5 or 6 teeth, occasionally 4 and 2 or 3 denticles.

Epigynum: The female of *T. gigantea* Chamberlin and Ivie was never described or illustrated, although female paratypes were designated. The following description of the epigynum was taken from females collected at the type locality.

The external epigynum consists of an irregular, convex median sclerite widened posteriorly. At each of the lateral edges is a depression and the opening of the spermathecae. Two broad, flat spurs extend over the lateral edges of the median sclerite toward the median line. The dull points of the spurs end at the three-quarter mark from the anterior end of the median sclerite.

Internally the strongly sclerotized epigynum is quite simple and slightly asymmetrical. One half is herewith described. The spermatheca consists of an irregular tube lying longitudinally and curving ventrally at the external opening where it is slightly constricted. The distal portion between the opening and the main portion of the spermatheca is bulbous and bears a short and blunt lateral projection as illustrated in Fig. 4.

Size: Males (12) range in size from 9.1 to 15 mm, averaging 12.02 mm; females (10) 11.8 to 17 mm, averaging 13.93 mm.

Distribution: Found only on the southern half of Vancouver Island, British Columbia. Many males and females from "Vancouver Island" collected by R. Guppy from May to October are in the American Museum of Natural History in New York City.

The male holotype was collected on "Vancouver Island," British Columbia, female allotype at Sidney, a small town 14 miles north of Victoria, British Columbia. Both types are deposited in the University of Utah.

STATUS OF OTHER "TEGENARIA" LISTED IN  
ROEWER'S "KATALOG DER ARANEAE"***Tegenaria arboricole* Walckenaer**

Abbot, 1792: 12, figs. 109, 110.

*Tegenaria arboricole* Walckenaer, 1841: 6 (♂).  
Fig. 110 of Abbot's.

*T. nemorensis* Walckenaer, 1841: 10-11 (in part,  
variety 2) (♀). Fig. 109 of Abbot's.

*T. arboricole* Walckenaer, Chamberlin and Ivie,  
1944: 128-129.

Chamberlin and Ivie (1944: 128-129) state,  
"It (Abbot's figure) is undoubtedly an *Agelenid*,  
but we are not certain of the genus so leave it in  
*Tegenaria* for the present."

Type locality: Georgia. Abbot's figure 110 was  
used as the basis for the description of *T. arbori-*  
*cole* Walckenaer. There apparently was no speci-  
men on hand at the time the description was  
drawn up.

***Tegenaria flavens* Hentz**

*Tegenaria?* *flavens* Hentz, 1847: 464, fig. 22 (♀).

After studying the illustration of *T. flavens*  
Hentz Dr. W. J. Gertsch stated, through cor-  
respondence, "*Tegenaria flavens* does not belong  
to the genus and probably not even to the fam-  
ily." The author is inclined to agree with him.

Type locality: Alabama. The type has appar-  
ently been lost.

***Tegenaria nemorensis* Walckenaer**

See *T. arboricole* Walckenaer and *Coras medi-*  
*cinalis* (Hentz).

Type locality: "Georgia." Abbot's figures 107  
to 109 were used as the basis for the description  
of *T. nemorensis* Walckenaer. There were appar-  
ently no specimens on hand at the time of the  
description.

***Tegenaria obscura* Banks**

*Tegenaria obscura* Banks, 1898: 230-231, fig. 26 (♀).

*Tegenaria obscura* Banks was described from a  
single female from "San Miguel de Horcasitas." This  
is probably the river which is now named  
Río de San Miguel, whose headwaters are about  
28 miles southeast of Nogales, Ariz., in Mexico.  
The type was deposited in the California Acad-  
emy of Sciences and was apparently lost during  
the San Francisco fire and earthquake of 1906.  
This species is close to and probably identical  
with *T. antrias* Crosby which has been collected  
in the southwestern part of the United States.

***Tegenaria praegrandis* Fox**

*Tegenaria praegrandis* Fox, 1937: 176-177, fig. 3 (♀).

*Tegenaria praegrandis* Fox was described from  
a single female from "Washington D. C. Dept.  
Grounds, Hothouse, outside" (Marx's catalog).  
A species as large as this (13.96 mm) and with  
the conspicuous habits of the genus would surely  
be collected again in 56 years. (No date was  
given, but Marx died in 1895.) In view of this  
and the fact that Marx's locality labels have  
often been found to be inaccurate, the author is  
including this species under the "unrecognized  
*Tegenaria*." The female is close to *T. gigantea*  
Chamberlin and Ivie but the genitalia are defi-  
nitely different. It will probably prove to be an  
exotic species.

The type (no. 1255) is deposited in the United  
States National Museum at Washington D. C.

***Calymmaria cavicola* (Banks)**

*Tegenaria cavicola* Banks, 1896: 202-203 (imm.).

*Calymmaria cavicola* Banks, Chamberlin and Ivie,  
1937: 213.

*Tegenaria cavicola* Banks, Roewer, 1944: 33.

*Calymmaria cavicola* Banks, Muma, 1945: 95.

***Calymmaria modestella* (Roewer)**

*Tegenaria modesta* Banks, 1898: 230, fig. 21 (♀).  
(Preoccupied by Keyserling 1877.)

*Calymmaria modesta* Banks, Chamberlin and Ivie,  
1937: 213.

*Tegenaria modestella* Roewer, 1944: 33 (new name).

***Calymmaria persica* (Hentz)**

*Tegenaria persica* Hentz, 1847: 463, fig. 23 (♀).

*T. persica* Hentz, Roewer, 1944: 33.

The type of *T. persica* Hentz has apparently  
been lost but the illustration given by Hentz  
indicated the probable genus. Dr. W. J. Gertsch  
states through correspondence, "*Tegenaria per-*  
*sica* Hentz is very clearly a *Calymmaria* and a  
species occurs in Alabama (the type locality of  
*T. persica* Hentz) which I have not been able  
to differentiate from (*Calymmaria*) *cavicola*  
Banks."

***Calymmaria quadrata* (Exline)**

*Tegenaria quadrata* Exline, 1936: 22, fig. 4 (♀).

*Calymmaria quadrata* Exline, Chamberlin and Ivie,  
1937: 213.

*Tegenaria quadrata* Exline, Roewer, 1944: 33.

***Coras medicinalis* (Hentz)**

Abbot, 1792: 12, figs. 107-108 (♂♀).

*Tegenaria medicinalis* Hentz, 1821: 53, figs. 1a, 1b.

*Tegenaria nemorensis* Walckenaer, 1841: 10-11 (in  
part, varieties 1 and 3) (♂♀). Figs. 107-108 of  
Abbot's.

*Coras medicinalis* Hentz, Chamberlin and Ivie 1944: 129.  
*Coras medicinalis* Hentz, Roewer, 1944: 20.  
*Tegenaria nemorensis* Walckenaer, Roewer, 1944: 33.  
*Coras medicinalis* Hentz, Muma, 1946: 4-5, figs. 1-3, 21-24 (♂ ♀).  
*Coras medicinalis* Hentz, Kaston. 1948: 281-282, figs. 900-902, 1914-1915 (♂ ♀).  
 See Roewer, 1944: 20 for additional synonymy.

LITERATURE CITED

ABBOT, JOHN T. *Drawings of the insects of Georgia, in America* 14: 116 plates. 1792. (MSS.)  
 BANKS, N. *Indiana caves and their fauna (arachnid section)*. Ann. Rep. Indiana Dept. Geol. and Nat. Res. 21: 202-205. 1896.  
 ———. *Arachnida from Baja California and other parts of Mexico*. Proc. California Acad. Sci. (Zool.), ser. 3, 1 (7): 205-308. 1898.  
 BRYANT, E. B. *New species of southern spiders*. Psyche 43(4): 1-79. 1935.  
 CHAMBERLIN, R. V., and IVIE, WILTON. *Miscellaneous new American spiders*. Bull. Univ. Utah 26(4): 1-79. 1935.  
 ———. *New spiders of the family Agelenidae from western North America*. Ann. Ent. Soc. Amer. 30(2): 211-241. 1937.  
 ———. *A hundred new species of American spiders*. Bull. Univ. Utah 32(13): 1-117. 1942.  
 ———. *Spiders of the Georgia region of North America*. Bull. Univ. Utah 35(9): 1-267. 1944.  
 CLERCK, C. *Aranei Suecici*: 1-154. Stockholm, 1757.  
 CROSBY, C. R. *Some arachnids from the Carlsbad Cave of New Mexico*. Proc. Ent. Soc. Washington 28(1): 1-5. 1926.

EXLINE, H. *New and little known species of Tegenaria (Agelenidae)*. Psyche 43(1): 21-25. 1936.  
 ———. *The Araneida of Washington: Agelenidae and Hahnidae*. Univ. Washington Publ. Biol. 9(1): 1-44. 1938.  
 ———. *Tegenaria agrestis (Walckenaer), a European agelenid spider introduced into Washington State*. Ann. Ent. Soc. Amer. 44(3): 308-310. 1951.  
 FOX, I. *Notes on North American agelenid spiders*. Can. Ent. 69: 174-177. 1937.  
 HENTZ, N. M. *A notice concerning the spiders whose web is used in medicine*. Journ. Acad. Nat. Sci. Philadelphia 2: 53-55. 1821.  
 ———. *Descriptions and figures of the Araneides of the United States*. Boston Journ. Nat. Hist. 5: 443-478. 1847.  
 KASTON, B. J. *The spiders of Connecticut*. State of Connecticut Public Document 47. State Geol. and Nat. Hist. Surv. Bull. 70: 1-874. 1948.  
 MUMA, M. H. *New and interesting spiders from Maryland*. Proc. Biol. Soc. Washington 58: 91-104. 1945.  
 ———. *North American Agelenidae of the genus Coras Simon*. Amer. Mus. Nov. 1329: 1-14. 1946.  
 PICKARD-CAMBRIDGE, F. O. *Araneida*. In Biologia Centrali-Americana 2: 313-424. 1902.  
 PICKARD-CAMBRIDGE, O. *On some new and little-known spiders from the Arctic regions*. Ann. Mag. Nat. Hist., ser. 4, 20: 273-285. 1877.  
 ROEWER, C. F. *Katalog der Araneae* 2: 1-160. Bremen, 1944.  
 WALCKENAER, C. A. *Faune Parisienne: Insectes* 2: 187-250 (spiders). Paris, 1802.  
 ———. *Histoire naturelle des insectes: Apteres* 2: 1-548. Paris, 1841.

ENTOMOLOGY.—*Johnsonaeopsylla audyi*, a new genus and new species of flea from North Borneo, with notes on the subfamily Leptopsyllinae (Siphonaptera).<sup>1</sup>  
 ROBERT TRAUB, Lt. Col., M.S.C., Army Medical Service Graduate School, Washington, D. C.

In connection with studies on the epidemiology of scrub typhus and leptospirosis, a joint U. S. Army-British Colonial Office Medical Research Team operated in North Borneo in July and August 1951. During the course of these investigations, fleas, mites, and other ectoparasites were collected from small mammals, particularly on Mount Kinabalu. Among the material represented in the valuable collections is the unusual flea herein described as a new genus and

new species of the family Ceratophyllidae, subfamily Leptopsyllinae. Fleas of this subfamily are frequently true parasites of *Rattus*, as well as of *Mus* and other mice, and hence are of potential medical significance.

A discussion of the subfamily Leptopsyllinae is included in this paper because of recorded differences of opinion as to the systematic position of this important group of fleas and because the new genus makes necessary a reevaluation of the diagnostic characters of the subfamily. This genus also indicates relationship between the Leptopsyllinae and the Amphipsyllinae.

<sup>1</sup> Published under the auspices of the Surgeon General, Department of the Army, who does not necessarily assume responsibility for the professional opinions expressed by the author.

## Family CERATOPHYLLIDAE

## Subfamily LEPTOPSYLLINAE

*Johnsonaeapsylla*, n. gen.

The only leptopsylline flea which lacks a genital tenidium or which has five pairs of lateral plantar bristles. Agrees with *Paractenopsyllus* Wagner, 1938, and *Peromyscopsylla* I. Fox, 1939, in the absence of a dark tuber above upper margin of the antennal groove in vicinity of the characteristic pale ring (Fig. 1, *RG.*). Agrees with *Paractenopsyllus* Wagner, 1938, in that the anterior portion of the head is normal in shape, not conical as in other leptopsyllines. Caput fractum. Eye distinct but somewhat reduced. Preantennal region with three rows of bristles, some of first row submarginal and somewhat spiniform. Frontal tubercle distinct. Postantennal area with three rows of bristles. Antennal segment 2 with bristles short; in male, not reaching beyond proximal fourth of club. Antennal groove not extending onto propleuron. Labial palpi much shorter than forecoxae. First vinculum or link-plate (*VC.1*) received in distinct sinus of prosternosome. Pronotal comb consisting of narrow spines. Pronotum with one row of long bristles. Some of dorsolateral bristles of protibiae short and straight, forming a reduced comb; these bristles on mesotibiae and metatibiae smaller, so that comb is vestigial (unlike other fleas in subfamily). Procoxae with many lateral bristles scattered over length of segment; other coxae with very few bristles and these on anteroventral margin. Profemora with very few lateral and mesal bristles. Mesosternum (Fig. 7, *MST.*) apparently enlarged so that metasternum appears as if divided into dorsal and ventral regions by an oblique sclerotization. Lateral metanotal area (*L.M.*) distinct. Pleural region of metasternosome fitting into well-sclerotized socket, the pleural arch (*PLA.*). Metanotum and some of typical abdominal terga with apical spinelets. Unmodified terga usually with two rows of bristles, but first row reduced, or absent on some. Spiracles subovate. Male with three antepygial bristles. Eighth tergum fairly well developed, extending as far caudad as middle of immovable clasper. Eighth sternum (Fig. 4, *SS.*) relatively large and unmodified. Digitoid (*F.*) with stout bristles but no spiniforms. Apical appendage of aedeagus (*AP.A.*) very well developed. Sclerotized inner tube (Fig. 9, *S.I.T.*) oblique and relatively unarmed, with distinct

apicomedian sclerite (*A.M.S.*). Crochets (*CR.*) very large and conspicuous. Distal arm of ninth sternum narrow and sinuate; without spiniforms.

The female of this genus is unknown.

Genotype: *Johnsonaeapsylla audyi*, n.sp.

The genus is named for Miss Phyllis Johnson, of the Department of Entomology, Army Medical Service Graduate School, Walter Reed Army Medical Center, Washington, D. C., one of the most promising students of medical entomology and to whom I am much indebted.

*Johnsonaeapsylla audyi*, n. sp.

*Types.*—Holotype male *ex Hylomys suillus* Muller, a small spineless hedgehog (Insectivora, Erinaceidae); North Borneo, Mount Kinabalu, elevation 5,000 feet, Tenompak; July 16, 1951; collected by R. Traub. Two paratype males with same data but from two other *Hylomys suillus*. A fourth paratype male, *ibid.*, but at Lumu Lumu, elevation 6,300 feet, in the cloud forest; July 21, 1951. Holotype deposited in the collections of the United States National Museum. Paratypes deposited in the Chicago Natural History Museum, the British Museum (Tring), and the author's collection.

*Head* (Fig. 1).—Preantennal region with bristles as follows: First row of six, ventral four of which are stout and more or less spiniform, particularly the upper two at level of frontal tubercle; second row of two large bristles, ventralmost submarginal; third row of two long bristles, uppermost at or somewhat above level of eye. Anterior arm of tentorium (*T.A.*) visible on each side as a rodlike structure anterior to eye. Eye subovate, small. Genal process subacute. Maxillary lobe with anterior wing weakly sclerotized but distinct, arising anterior to base of maxillary palpi. The more heavily sclerotized portion (that area usually depicted in drawings of maxillary lobes of most fleas) originating definitely posterior to these palpi. Apex of maxillary lobe extending distad of base of fourth segment of maxillary palpi. Labial palpi 5-segmented, extending three-fourths length of forecoxae. Scape of antenna with about three short dorsomarginal subapical bristles. Second antennal segment with apical bristles short, not reaching beyond apex of third segment of club. Postantennal region with rows of bristles arranged 3-4 (5)-6 per side, ventralmost of last row displaced to ventrocaudal angle; at

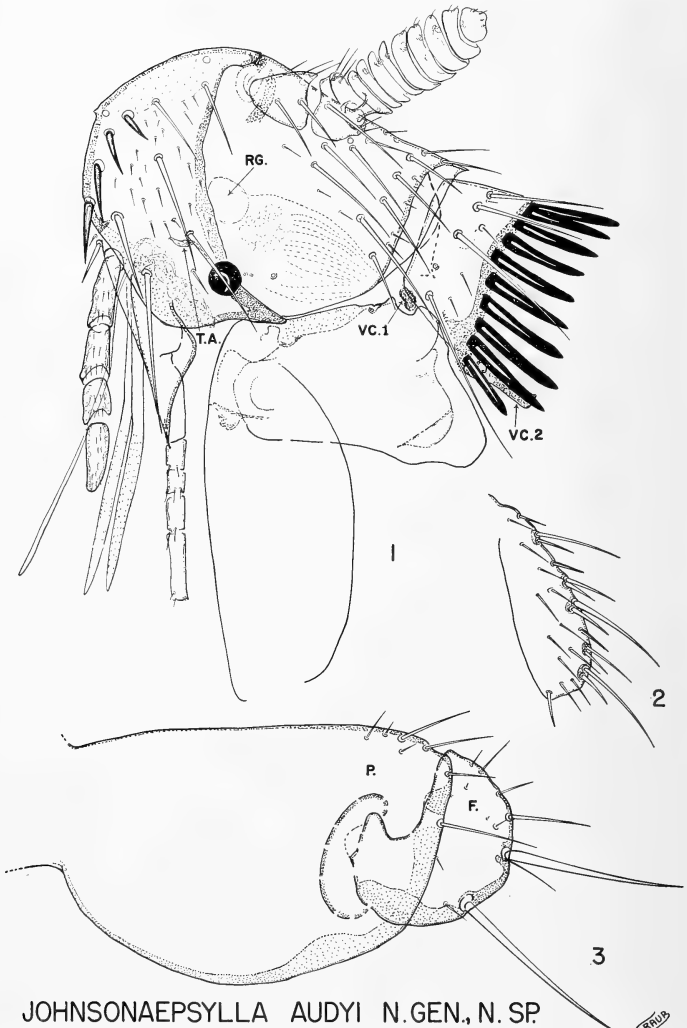

JOHNSONAEPSYLLA AUDYI N.GEN., N.SP.

FIG. 1.—Head and prothorax, male. FIG. 2—Protibia. FIG. 3.—Immovable process of clasper and digitoid.

TRAUB

times with an additional dorsomarginal bristle at base of flange; intercalaries displaced caudad along margin of flange. First vinculum or link plate (*VC.1.*) somewhat irregular in shape, at times subpyriform.

*Thorax.*—Pronotum with a row of four or five long bristles; small intercalaries displaced caudad; with a comb of about 10 or 11 spines on a side; the spines straight or slightly concave. Second vinculum (*VC.2.*) almost completely concealed by lower spines of pronotal comb; very broad at base, apex upcurved where it hooks onto mesepisternum. Mesonotum (Fig. 7, *MSN.*) with about four rows of bristles, first row of shortest bristles, those of last row longest, about four in number; ventralmost arising above midpoint of notum. Mesonotal flange on each side with a subdorsal pseudoseta (*PS.S.*). Mesopleuron with a total of about 11 or 12 bristles, of which two to four appear to be on mesepisternum (*MPS.*), the remainder on mesepimere (*MPM.*). Metanotum, together with its flange, slightly longer than mesonotum; with three rows of bristles, none extending ventrad to midline. Metanotal flange with a dorso-apical tooth. Lateral metanotal area (*L.M.*) almost twice as long as broad; with two bristles, dorsomarginal the longer. Metepisternum (*MES.*) with one long bristle in posterodorsal region. Metepimere (*MTM.*) with about seven long bristles arranged 3-3-1.

*Legs.*—Profemur with about four lateral non-marginal bristles, mesofemur and metafemur with about three or four subapical, lateral bristles; none on apicoventral flange. Legs long and narrow, e.g., metatarsal segment one almost six times as long as broad. Protibia (Fig. 2) with five pairs of dorsomarginal bristles and with a single stout bristle between dorsalmost and second pairs and another such bristle between third and fourth pairs. Mesotibia and metatibia the same but three of these pairs much more conspicuous and of longer bristles than the others; also differing in that there are two single stout bristles between third and fourth pairs. None of tarsal bristles reaching beyond apex of following segment. Measurements (in microns) of tibiae and segments of tarsi (petiolate base deleted) of holotype:

Leg	Tibia	Tarsal Segments				
		I	II	III	IV	V
Pro-	225	95	90	80	55	120
Meso-	340	190	145	100	60	125
Meta-	450	330	220	135	75	140

*Abdomen.*—First tergum (*IT.*) with two rows of bristles and one or two subdorsal spinelets. Basal sternum with one ventromarginal bristle on each side. Terga II to V with with one apical spinelet per side. Second terga with first row of bristles represented by three bristles, third and fourth terga with one or two such bristles; remaining unmodified terga with but one row of bristles; second row of bristles extending slightly below spiracle in each case. Typical sterna with two subdorsal bristles per side. Antepygidial (antesensillar) bristles with middle bristle twice length of lower bristle; upper bristle slightly shorter than lower.

*Modified abdominal segments* (Fig. 4).—Eighth tergum (*ST.*) extending as far caudad as base of acetabulum and ventrad to upper portion of aedeagal apodeme; with a long apical bristle and two long median bristles, one of these below sensillum. Eighth sternum extending apicad only to about level proximad of midpoint of distal arm of ninth sternum; extending dorsad slightly above manubrium and therefore somewhat broader than long; with two subventral bristles.

Immovable process of clasper (*P.* and Fig. 3.) subovate, about two-thirds or three-fourths as broad as long; dorsal margin slightly convex; ventral margin evenly convex, caudal margin fairly straight. Process *P.* with two dorsomarginal subapical bristles and two or three much smaller bristles adjacent to antermost of these; caudal margin with a subapical bristle and a longer bristle well above midpoint, the last suggestive of characteristic bristle of so many leptopsylline fleas and perhaps homologous with acetabular bristles of true ceratophyllid fleas. Movable finger or digitoid (*F.*) inserted relatively well proximad on *P.*; almost twice as long as broad, but basally recurved; anterior margin apically fairly straight; posterior margin convex. *F.* with two long bristles, one at midpoint and one at proximal third; caudal margin with three or four much smaller bristles above stout median bristle; then a few scattered hairs. Manubrium (*MB.*) long and narrow, apically somewhat upturned.

Ninth sternum with proximal arm (*P.A.9*) slightly longer than distal arm (*D.A.9*); relatively long and narrow, apically subacuminate, resembling slightly crooked finger. Distal arm of ninth sternum (*D.A.9* and Fig. 6.) also relatively long and narrow. Morphological ventral

margin markedly sinuate at apical third, the resulting convexity or lobe bearing four bristles, two of which are quite long; apical portion of arm above sinus distally ovate; with three sub-apical marginal thin bristles; with about five or six dorsomarginal bristles and three or four small scattered bristles. Aedeagal apodeme (*A.E.A.*) almost three times as long as portion of aedeagus distad of apodemal strut; over three times as long as broad; with a very well developed apical appendage (*A.P.A.*) and a well-developed proximal spur (Fig. 9, *P.S.*). Median dorsal lobe (*M.D.L.*) shallowly convex and turning straight ventrad; apically subtruncate and recurved; with a pair of long narrow apicomedian sclerites (*A.M.S.*) which are distally angled and expanded ventrad. Crochets (*CR.*) very large, longer than endchamber distad of apodemal strut; twice as long as broad, but with apical half conspicuously narrowed and upcurved, so that distal portion of crochet resembles geologist's hammer. Sclerotized inner tube (*S.I.T.*) fairly short, about twice as long as broad at maximum, oblique, with distinct sclerotized band of inner tube (*B.I.T.*) extending from its apex. Armature of inner tube (*A.I.T.*) represented as two dorsal spurs. Lateral lobes (*L.L.*) weakly sclerotized, extending from wall of aedeagal pouch to base of crochet at proximal portion of *S.I.T.* Wall of aedeagal pouch (*P.W.*) extending as a straight line from proximal spur; ventrally somewhat convex. Penis rods (*P.R.*) long but not fully coiled, paralleling apodemal rod of ninth sternum. Ventral intramural rod of endophallus (*I.R.*) heavily sclerotized. Sclerites of apodemal strut (*A.P.S.*) not clearly defined. Tenth segment conspicuous; sensillum (Fig. 4, *SN.*) very flat; with about 17 pits per side. Dorsal lobe of proctiger (*D.A.L.* and Fig. 5.) with four or five dorsomarginal and two ventromarginal bristles. Ventral lobe (*V.A.L.*) of proctiger with two subapical ventromarginal bristles, its dorsal margin weakly sclerotized.

The species is named for Dr. J. R. Audy, director of the Colonial Office Scrub Typhus Research Unit, Kuala Lumpur, Malaya, who has contributed much to our knowledge of arthropod-borne diseases. As a member of the U. S. Army Medical Research Units in Malaya and Borneo, 1948-1951, I am particularly indebted to him for his splendid cooperation throughout the course of our investigations.

#### DISCUSSION OF THE SUBFAMILY LEPTOPSYLLINAE

Fleas of the subfamily Leptopsyllinae are characteristic parasites of murid and ericetid rodents and of certain insectivores. As a group these fleas are widely distributed, indigenous forms being known from Europe; much of Asia, including the Middle East, Asiatic U.S.S.R., and China; Africa; North America; New Guinea; North Borneo and the Philippines.<sup>2</sup> Some confusion exists in the literature as to the systematic position of *Leptopsylla* Jordan and Rothschild, 1911, and its allies: *Peromyscopsylla* I. Fox, 1939, *Pectinoctenus* Wagner, 1929, *Paractenopsyllus* Wagner, 1938, and *Sigmactenus* Traub, 1950. According to the traditional emphasis upon presence of a genal comb and of a fracticipit head-capsule, these fleas belong to the Hystrichopsyllidae. More recent workers, studying independently, and to a certain extent utilizing different morphological characters, have stated that this complex belongs with the ceratophyllid fleas (3, 4, 6, 7). It is felt by these students that the presence or absence of genal spines or a fracticipit condition does not necessarily indicate fundamental relationship. For this reason Traub (6) restored the combless<sup>3</sup> *Catallagia* Rothschild, 1915, to proximity with the combed *Epitedia* Jordan, 1938, and *Neopsylla* Wagner, 1933 (a position intended by the authors), instead of leaving it in the "Dolichopsyllidae" where it had been placed among combless fleas which were otherwise very different morphologically (1, 2).

*Leptopsylla* and allies agree with the ceratophyllid fleas in the following characters (*partim*): (1) Metanotum with apical spines; (2) sensillum dorsally straight; (3) male with third aedeagal rod arising as a tendon from the ninth sternum; (4) male eighth tergum large, enclosing much or most of genitalia; (5) male eighth sternum correspondingly reduced, covering relatively little of genitalia; (6) aedeagal crochets typically very large, movable, articulated ventrally near base of sclerotized inner tube.

<sup>2</sup> *Acropsylla* Rothschild is now regarded by some workers as belonging in the tribe Mesopsyllini, subfamily Amphisyllinae, a group of fleas related to the Leptopsyllinae, as shown below. *Acropsylla* occurs in India and Burma.

<sup>3</sup> The comb referred to is the genal ctenidium and not the pronotal comb.



In contrast, the Hystrichopsyllidae may be characterized as follows: (1) Metanotum lacking apical spines; (2) sensilium more or less convex; (3) third aedeagal rod free, lying within end-chamber and not definitely arising as a tendon

from the ninth sternum; (4) male eighth tergum reduced, enclosing very little of genitalia; (5) male eighth sternum correspondingly enlarged, ensheathing much of genitalia; (6) crochets relatively small, not freely movable.

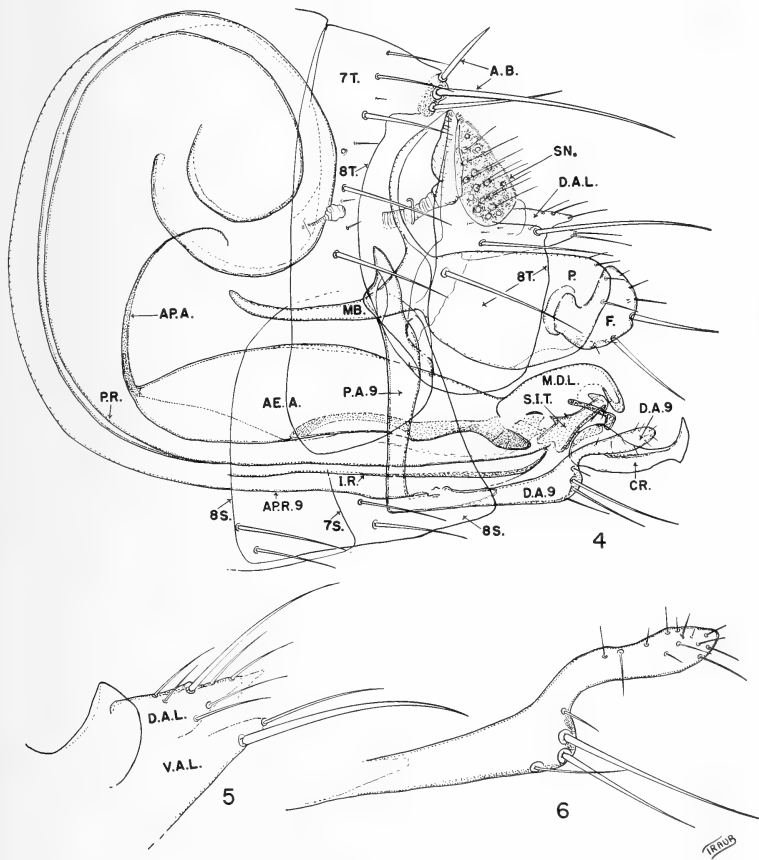

**JOHNSONAEPSYLLA AUDYI, N. GEN., N. SP.**

FIG. 4.—Modified abdominal segments, male. FIG. 5.—Dorsal and ventral anal lobes. FIG. 6.—Distal arm of ninth sternum.

The Leptopsyllinae<sup>4</sup> prior to the discovery of *Johnsonaeopsylla*, n. gen., could be separated from true ceratophyllids thusly: (1) Genal comb present; (2) arch of endoskeleton visible as tentorial arm (Fig. 1, T.A.) in front of eye; (3) fracticipit; (4) antennal groove closed so that club of male antenna does not extend onto propleuron; (5) upper eye bristle not directly in front of eye; (6) some of head bristles stout and slightly curved, "spiniform"; (7) an ovate pale area or ring (Fig. 1, R.D.) above ventral margin of antennal groove, near midpoint of groove; (8) male eighth tergum relatively smaller, not completely enclosing genitalia, extending caudad only to about middle of claspers and ventrad to middle of proximal arm of ninth sternum; (9) male eighth sternum correspondingly larger, extending dorsad to near base of clasper.

The following additional characters are typical of the Leptopsyllinae but may occur in true ceratophyllids: (10) Eye vestigial; (11) dorsolateral bristles of tibia forming a false comb; (12) crochets lacking a well-defined basal peglike or barrel-shaped sclerotization (if the peg is indicated it is ventromarginal); (13) a characteristic, long submedian marginal bristle on the immovable process (items 10 through 13 rarely occur in the Ceratophyllidae); (14) last segment of tarsi with four pairs of stout lateral plantar bristles and one pair of mesal plantar bristles.

*Johnsonaeopsylla*, n. gen., does not fit with this diagnosis of the subfamily in that it possesses a distinct (although somewhat reduced) eye, and lacks a genal comb, while the tibial false combs are so reduced (or undeveloped) as to be almost inapparent. *Johnsonaeopsylla* is also unique in possessing five lateral plantar bristles on the last tarsal segment of each leg.

It has been pointed out above that it is compatible with a concept of dynamic evolution for related fleas to differ regarding the presence of a genal comb. Similarly, many instances are known in which "blind" fleas very closely resemble species with well-developed eyes. In-

<sup>4</sup> Jordan, in Smart (4), treats *Leptopsylla* and allies in a separate family within an undeclared superfamily of ceratophyllid fleas. In litt., Dr. Jordan agrees that certain of the "families" in this chapter could equally well be considered "subfamilies" today, as I am doing in this paper. Our present state of knowledge of the higher classification of fleas is insufficient to categorically define superfamilies, families, and subfamilies, even though many authors now agree as to the various "groups" of fleas.

deed, reduction of eyes in fleas is frequently adaptive and correlated with parasitism of subterranean and/or nocturnal hosts (cf. *Pulex sinoculus* Traub, 1950, and *P. irritans* Linnaeus (6)). The presence of a genal tentidium is highly correlated with that of a reduced eye, while combless fleas usually have well-developed eyes, unless parasitizing a subterranean host (6, 8). *Jellisonia* Traub, 1944, is an example of a genus in which certain species have well-developed tibial "combs" and others have lost this structure on some legs (6, 9). *Stivalius* is another case where some forms have well-developed tibial "combs," while most species lack them (5). The number of lateral plantar bristles on the tarsi also varies in related genera.

For these reasons I feel that these differences between *Johnsonaeopsylla* and other leptopsyllines are secondary, not fundamental, and that *Johnsonaeopsylla* is merely an unspecialized if not somewhat primitive form. *Johnsonaeopsylla* agrees with the basic, essential characteristics of the leptopsyllines—those listed as numbers 2, 3, 4, 6, 7, 8, 9, and 13 above, while its genitalia are of a pattern typical of the subfamily. This new genus agrees with *Leptopsylla* and allies in two other characteristics typical (but not exclusive) of the group—viz, the maxillary lobe has a relatively well sclerotized wing which clearly arises anterior to base of the maxillary calpi, instead of being virtually invisible as in most fleas; the male proctiger has a distinct basal transparent collar or flange. The preantennal region is much more rounded in *Johnsonaeopsylla* than in typical leptopsyllines, where this region is subconical. However, *Paractenopsyllus* also lacks a conical frons.

*Johnsonaeopsylla* indicates a close relationship with the Amphipsyllinae and in my opinion links the Leptopsyllinae with the Amphipsyllinae. Thus, fleas of the latter subfamily possess a visible tentorial arch, and may lack a genal tentidium. At times there is an indication of the interantennal suture and certain of these fleas possess the pale ring above the lower margin of the antennal groove. Some of these fleas have distinct eyes, while pre-antennal bristles modified so as to suggest spiniforms occur in *Ctenophyllus* Wagner, 1927. In the Amphipsyllinae, however, the male eighth sternum is well developed, large, and/or modified. The head is normally integrecipit, and if there is a suture indicated, it is not as apparent as in *Johnsonaeopsylla*, in

which it is well developed as in such typical leptosyllids as *Peromyscopsylla*. The peglike sclerotization of the crochet is usually well indicated in the Amphipsyllinae.

SUMMARY

*Johnsonaeopsylla audyi*, n. gen. and n. sp., collected ex *Hylomys* on Mount Kinabalu, North Borneo, is described and figured.

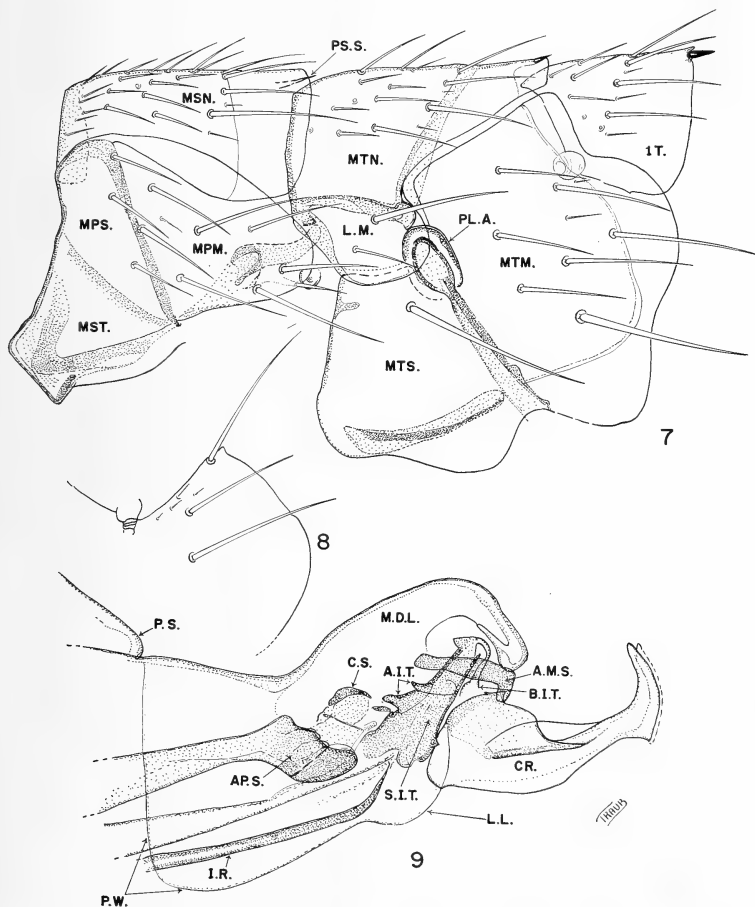

JOHNSONAEPSYLLA AUDYI, N. GEN., N. SP.

FIG. 7.—Mesothorax and metathorax. FIG. 8.—Eighth tergum (*partim*), male. FIG. 9.—Apical portion of aedeagus.

The genus is unique in the subfamily Leptopsyllinae in that it lacks a genal ctenidium and it possesses a distinct eye and has five pairs of lateral plantar bristles on the last segment of the tarsi. While essentially an unspecialized leptopsylline flea, the new genus links this subfamily with the Amphipsyllinae.

## ACKNOWLEDGMENTS

I am indebted to Dr. Karl Jordan, F. R. S., and Messrs. G. H. E. Hopkins and F. G. A. M. Smit, of the British Museum, for verification of the status of this interesting genus and for pertinent and valuable comments. Certain of the characteristics of the Leptopsyllinae listed herein are based in part upon observations by Jordan and Hopkins *in litt.*

## REFERENCES

- (1) EWING, H. E. *A manual of external parasites*: 225 pp., 96 figs. 1929.
- (2) EWING, H. E., and FOX, I. *The fleas of North America*. U. S. Dept. Agr. Misc. Publ. 500: 1-142. 1943.
- (3) HOLLAND, G. P. *The Siphonaptera of Canada*. Dominion of Canada Dept. Agr. Techn. Bull. 70: 1-306, 350 figs. 1949.
- (4) JORDAN, K. Chapter on "Fleas" in Smart, J. *Insects of medical importance*: 211-245. British Museum, London, 1948.
- (5) JORDAN, K., and ROTHSCHILD, N. C. *On Pygiopsylla and the allied genera of Siphonaptera*. *Ectoparasites* 1: 231-265, 56 figs. 1922.
- (6) TRAUB, R. *Siphonaptera from Central America and Mexico*. *Fieldiana: Zoology Memoirs* 1: 1-127, 54 pls. 1950.
- (7) ———. *Notes on Indo-Malayan fleas, with descriptions of new species*. *Proc. Ent. Soc. Washington* 52(3): 109-143, 64 figs. 1950.
- (8) ———. *Hoogstraalia turdella, a new genus and species of flea from the Philippines*. *Proc. Ent. Soc. Washington* 53(2): 97-104, figs. 1-11. 1951.
- (9) TRAUB, R., and JOHNSON, P. T. *Atyphloceras tancitari, and Jellisonia bonia, new species of fleas from Mexico*. *Amer. Mus. Nov. no.* 1558: 1-19. figs. 1-24, 1952.

## LIST OF ABBREVIATIONS

AE.A.	Aedeagal apodeme.
A.I.T.	Armature of inner tube of aedeagus.
A.M.S.	Apicomedian sclerites of aedeagus.
APA.	Apical appendage of aedeagus.
AP.S.	Sclerite of apodemal strut.
B.I.T.	Band of inner tube extending distad of apex of sclerotized inner tube.
CR.	Crochet of aedeagus.
D.A.L.	Dorsal anal lobe.
D.A.9	Distal arm of ninth sternum.
F.	Digitoid or movable finger.
I.R.	Ventral intramural rod of endophallus.
L.M.	Lateral metanotal area.
MB.	Manubrium
M.D.L.	Median dorsal lobe.
MPM.	Mesepimere
MSN.	Mesonotum
MPS.	Mesepisternum
MTM.	Metepimere
MST.	Mesosternum
MTS.	Metepisternum
P.	Immovable process of clasper.
P.A. 9	Proximal arm of ninth sternum.
PL.A.	Pleural arch of metathorax.
P.R.	Penis rods.
P.S.	Proximal spur of aedeagus.
P.S.S.	Pseudoseta
P.W.	Wall of aedeagal pouch.
RG.	Pale ring above ventral margin of antennal groove.
S.I.T.	Sclerotized inner tube.
SN.	Sensillum
T.A.	Anterior tentorial arm of endoskeleton.
V.A.L.	Ventral anal lobe.
VC. 1	First vinculum or link-plate.
VC. 2	Second vinculum or link-plate.
SS.	Eighth sternum.
1T.	First tergum.

MALACOLOGY.—*Generic and subgeneric names in the molluscan class Scaphopoda.*<sup>1</sup>

WILLIAM K. EMERSON,<sup>2</sup> Museum of Paleontology, University of California.  
(Communicated by Harald A. Rehder.)

The supraspecific categories of the molluscan class Scaphopoda have not received serious study for more than 50 years. In the light of present knowledge it is apparent that they are in need of taxonomic review. The purpose of this paper is to indicate the

nomenclatural units that are available for future taxonomic and phylogenetic work in the class.

The Scaphopoda, the smallest of the five classes of the phylum Mollusca, are divided into the families Dentaliidae and the Siphonodentaliidae.<sup>3</sup> The families are distin-

<sup>1</sup> Contribution no. 66 from the Allan Hancock Foundation, University of Southern California.

<sup>2</sup> Formerly of the Allan Hancock Foundation, University of Southern California.

<sup>3</sup> D. K. Greger, 1933, p. 373, described *Thro-opella typa*, n. gen., n. sp., from the Devonian of

guished from each other by differences in the median tooth of the radula, the form of the foot, and certain definite shell characters. The reader is referred to the excellent monographs by Pilsbry and Sharp (1897-98) and Henderson (1920) for keys which differentiate the two families and for the distinguishing characters of the genera and subgenera which comprise the two families.

With the exception of the fossil genus *Plagioglypta*, the genus *Dentalium* (*sensu lato*) has been considered by many taxonomists to include all the remaining representatives of the family Dentaliidae. Thus, the genus *Dentalium* has been divided into a number of subgenera, some of which are of much greater biological significance than others. On the other hand, most students have recognized for the Siphonodentaliidae three genera, *Entalina*, *Siphonodentalium*, and *Cadulus*. The last named has been divided into several subgenera and sections. While some of these nomenclatural units are useful for distinguishing evolutionary trends, many are objectionable synonyms of no apparent taxonomic significance.

A number of tubicolous gastropod shells and calcareous worm tubes were described as scaphopods during the early period of systematics. Thus, tubes of the gastropod family Caecidae and the annelid family Serpulidae form a sizable list of spurious scaphopods. Some of the Siphonodentaliidae were originally assigned to vermian genera by their describers.

*Procedure.*—All scaphopod generic and subgeneric names known to the writer are reviewed and the genotype (type species) of each valid supraspecific unit is indicated. In order to retain a purely objective approach, no distinction is made between genera, subgenera, and "sections." It is beyond the scope of this paper to evaluate their taxonomic rank. Such an evaluation is reserved for a future paper.

The nomenclatural units are listed alphabetically with the valid names in boldface letters and the invalid names in italics.<sup>4</sup>

---

central Missouri. Should this actually prove to be a scaphopod, a new family would have to be formed to contain it.

<sup>4</sup> The changes in the Règles made by the 1948 meeting of the International Commission on

Although the capitalized names are valid, many are junior synonyms and, therefore, are not available taxonomically. Names which are objective synonyms<sup>5</sup> of earlier valid names are so indicated. Every effort has been made to rigidly follow the International Rules of Zoological Nomenclature in establishing the types of the genera. In order to prevent any misunderstanding with regard to the selection of the types, and thus the generic concepts, the reason governing the type selection is given. Fortunately, the majority of the names have original designations or are monotypic. In cases of subsequent designations, the species originally contained in the genus are listed together with the author and the date of the subsequent designation. By possessing these data the reader may determine the validity of possible earlier designations without having access to the original description. The source of the original description is cited for each genotype and reference is made to a generally accessible subsequent description and illustration. Inasmuch as the locality data for the fossil and living species were obtained principally from Pilsbry and Sharp (1897), the majority of the geologic age assignments is of that date.

*Acknowledgments.*—The author is indebted to Drs. Harald A. Rehder and David Nicol, of the United States National Museum, for checking otherwise inaccessible references; to Dr. William H. Easton, professor of geology, University of Southern California, for many helpful suggestions and criticisms, and to the administration of the Allan Hancock Foundation for material aid.

---

Zoological Nomenclature became effective January 1, 1951. While the official Règles are not at this date in print, it is the author's understanding that under the revised Règles emendations of generic names whether justified or not, preoccupy for the purpose of homonymy, and erroneous emendations are available as junior synonyms in cases where the original names are later rejected. This change creates a rather unfortunate and nearly infeasible system for determining the next available junior synonym in cases of rejected names. Until this situation is clarified, it seems proper to consider unjustified emendations as being invalid and unavailable.

<sup>5</sup> Objective or absolute synonyms are those having identical genotype species.

GENERA AND SUBGENERA ALPHABETICALLY  
ARRANGED

DENTALIIDAE

- Antale** Sacco, 1896, p. 97, for *Antale vulgare* (Da Costa), etc. Genotype: (by subsequent designation), Sacco, 1897, p. 98) *Antale vulgare* (Da Costa), 1778, p. 28; Pilsbry and Sharp, 1897, p. 41, pl. 8, figs. 22-24. Recent, Mediterranean and Adriatic Seas, Northeastern Atlantic Ocean; Pliocene of Italy. Name taken from *Antale* of "Aldrov. [andus] 1618." A junior objective synonym of *Dentale* Da Costa, 1778. Used by subsequent authors, e. g., Rovereto, 1900, p. 201, and Cossmann and Peyrot, 1916, p. 160.
- Antalis** Herrmannsen, 1846, vol. 1, p. 63 (genus without species; first species assigned by H. and A. Adams, 1854, vol. 1, p. 457, for 16 species, including "*Antalis entalis* Linn."). Genotype: (by subsequent designation, Pilsbry and Sharp, 1897, p. 37) *Dentalium entalis* Linné, 1758, p. 758; Pilsbry and Sharp, 1897, p. 42, pl. 8, fig. 25. Recent, North Atlantic Ocean. Herrmannsen, 1846, proposed *Antalis* without species from *Antale* Aldrovandus, 1606, see Emerson, 1951, p. 17. *Antalis* is often attributed to H. and A. Adams, 1854, vol. 1, p. 457, genotype: (by subsequent designation, Pilsbry and Sharp, 1897, p. 37) *Dentalium entalis* Linné, 1758, p. 758.
- Bathoxiphon** Pilsbry and Sharp, 1897, p. 121, for *Dentalium ensiculus* Jeffreys, 1877, *D. ensiculus* var. *didymum* Watson, 1879. Genotype: (by subsequent designation, Boissevain, 1906 p. 48) *Dentalium ensiculus* Jeffreys, 1877, p. 154; Henderson, 1920, p. 81, pl. 14, figs. 1, 4, 5, 7, 9. Recent, Atlantic Ocean in deep water.
- Coccodentalium** Sacco, 1896, p. 98. Genotype: (by original designation) *Coccodentalium radula* (Schroeter, 1784), p. 530; Sacco, 1897, p. 111, pl. 10, figs. 7-21. Miocene, Piedmont of Italy.
- Compressidens** Pilsbry and Sharp, 1897, p. 123. (See under family Siphonodentaliidae.)
- Dentale** Da Costa, 1778, p. 24. Genotype: (by monotypy) *Dentale vulgare* Da Costa, 1778, p. 24, pl. 2, fig. 10; Pilsbry and Sharp, 1897, p. 41, pl. 8, figs. 22-24. Recent, Mediterranean and Adriatic Seas; Atlantic Ocean from Spain to Belgium, etc.; Miocene of Belgium, Pliocene of Italy. For a review of the synonymy of this unit see Emerson, 1951, p. 19.
- Dentalia** Perry, 1811, pl. 52, for *Dentalia viridis* Perry, 1811, *D. bandata* Perry, 1811, *D. denacta* Perry, 1811. Genotype: (here designated) *Dentalia viridis* Perry, 1811, p. 52 = *Dentalium elephantinum* Linné, 1758. As a result of the above designation, *Dentalia* is a junior "objective" synonym of *Dentalium* Linné, 1758.
- Dentalium* Pilsbry and Sharp, 1897, p. xxviii. Error for *Dentalium* Linné, 1758.
- Dentalites** Schlotheim, 1813, pp. 91, 100, 110, for *Dentalitus striatus*, *D. obsoletus*, and *D. minutus*, nude names. Genotype: (here designated) *Dentalium elephantinum* Linné, 1758, p. 785. With the above designation *Dentalites* is a junior objective synonym of *Dentalium* Linné, 1758.
- Dentalium** Linné, 1758, p. 785, for *D. elephantinum* L., *D. Dentalis* L., *D. Entalis* L., *D. minutum* L. Genotype: (by subsequent designation, Montfort, 1810, p. 23) *Dentalium elephantinum* Linné, 1758, p. 785; Pilsbry and Sharp, 1897, p. 1, pl. 1, figs. 1-7. Recent, Amboyna and Philippine Islands.
- Dentalius* Forbes, 1841, p. 253, for "*Dentalius Entalis*." Error for *Dentalium* Linné, 1758.
- Dentalium* Krotow, 1885, p. 153. Error for *Dentalium* Linné, 1758.
- Entale** Herrmannsen, 1848, vol. 1, p. 423 (genus without species). Genotype: (here designated) *Dentalium elephantinum* Linné, 1758, p. 785. As a result of the above designation, *Entale* is a junior objective synonym of *Dentalium* Linné, 1758. Name taken from *Entale* of Tournefort in Gualtieri, 1742. No species were validly assigned but a brief description was given.
- Entaliopsis** Newton and Harris, 1894, p. 66. Genotype: (by original designation) *Dentalium entalis* Linné, 1767, p. 1263 = *D. entalis* Linné, 1758, p. 785. Proposed as a new name for the preoccupied *Entalis* of Gray, 1847, not Sowerby, 1839, an annelid genus. *Entaliopsis* is a junior objective synonym of *Antalis* Herrmannsen, 1846.
- Entalis* Gray, 1847, p. 158. Genotype: (by original designation) "*Dentalium e[ntalis]* Desh. [ayes] 1825" p. 359 = *Dentalium entalis* Linné, 1785, p. 785; Pilsbry and Sharp, 1897, p. 43, pl. 8, fig. 25. Recent, Atlantic Ocean. Not *Entalis* Sowerby, 1839, p. 42 (Annelida, Serpulidae). A junior objective synonym of *Antalis* Herrmannsen, 1846.
- Episiphon** Pilsbry and Sharp, 1897, p. 117, for *Dentalium sowerbyi* Guilding, 1834, *D. fistula* Sowerby, 1860, *D. filum* Sowerby, 1860, *D. innumerabile* Pilsbry and Sharp, 1897, *D. subrectum* Jeffreys, 1882, *D. longum* Sharp and Pilsbry, 1897, *D. tornatum* Watson, 1879. Genotype: (by subsequent designation, Suter, 1913, p. 821) *Dentalium sowerbyi* Guilding, 1834, p. 35, pl. 3, fig. 7; Henderson, 1920, p. 77, pl. 13, figs. 2, 3, 10. Recent, off Southeastern United States and West Indies.

- Eudentalium** Cotton and Godfrey, 1933, p. 140. Genotype: (by original designation) *Dentalium quadricostatum* Brazier, 1877, p. 58. Recent, Princess Charlotte Bay, Australia; Katow, New Guinea.
- Fissidentalium** Fischer, 1885, p. 894. Genotype: (by monotypy) *Dentalium ergasticum* Fischer, 1882, p. 275; Pilsbry and Sharp, 1897, p. 74, pl. 15, figs. 35-36. Recent, Gulf of Gascony and Atlantic Ocean in deep water.
- Fustaria* Noszky, 1936, p. 83. Error for *Fustaria* Stoliczka, 1868.
- Fustaria** Stoliczka, 1868, p. 439, for *Dentalium circinatum* Sowerby, 1823, *D. eburneum* Lamarek, 1818 = *D. eburneum* Linné, 1767. Genotype: (by subsequent designation, Newton and Harris, 1894, p. 64) *Dentalium eburneum* Linné, 1767, p. 1264; Pilsbry and Sharp, 1897, p. 115, pl. 20, figs. 33, 34. Recent, South Pacific.
- Gadilina** Foresti, 1895, p. 259. Genotype: (by monotypy) *Siphodontalium (Gadilina) triquetrum* (Brocchi), 1814, p. 628; Sacco, 1897, p. 113, pl. 10, figs. 35-46. Miocene, Piedmont of Italy.
- Graptacme** Pilsbry and Sharp, 1897, p. 85, for *D. sericatum* Dall, 1881, *D. circumcinctum* Watson, 1879, *D. eboeum* Conrad, 1846, *D. leptum* Bush, 1885, *D. semistriatum* Turton, 1819, *D. semistriatum* var. *semipolatum* Broderip and Sowerby, 1829, *D. aciculum* Gould, 1859, *D. novaeahollandiae* Chenu, 1858, *D. acutissimum* Watson, 1879, *D. inversum* Deshayes, 1825, *D. splendidum* Sowerby, 1832. Genotype: (by subsequent designation, Woodring, 1925, p. 201) *Dentalium eboeum* Conrad, 1846, p. 27; Pilsbry and Sharp, 1897, p. 89, pl. 16, figs. 47-49, 55-56. Recent, off Southeastern United States and West Indies.
- Heteroschisma* Simroth in Bronn, 1895, p. 460, for *Dentalium inversum* Deshayes, 1825, *D. subterfissum* Jeffreys, 1877, *D. Leoninae* Meunier, 1878. Genotype: (here designated) *D. subterfissum* Jeffreys, 1877, p. 154; Pilsbry and Sharp, 1897, p. 61, pl. 7, figs. 15-19. Not *Heteroschisma* Wachsmuth, 1883, (Echinodermata), nor Kofoid and Skogsberg, 1928, (Protozoa). Since this is not considered to be a natural biological unit no new name is here proposed.
- Laevidentalium** Cossmann, 1888, p. 7. Genotype: (by original designation) *Dentalium incertum* Deshayes, 1825, p. 362, pl. 7, fig. 17. Eocene of Paris Basin.
- Lobantale** Cossmann, 1888, p. 7. Genotype: (by original designation) *Dentalium duplex* De-france, 1819, p. 71; Pilsbry and Sharp, 1898, p. 203, pl. 39, fig. 12. Eocene of Paris Basin.
- Paradentalium** Cotton and Godfrey, 1933, p. 139. Genotype: (by original designation) "*D. [entalium] intercalatum* Gould, 1859," p. 166; Pilsbry and Sharp, 1897, p. 23, pl. 11, figs. 88-89. Recent, "China Seas." Cotton and Ludbrook, 1938, p. 218, state that *D. intercalatum* of Cotton and Godfrey, 1933, was misidentified, being actually *D. bednalli* Pilsbry and Sharp, 1897, p. 248, and that the genotype of *Paradentalium* thus should be considered the *D. bednalli*. In the case of a misidentified genotype, the original genotypic concept can not be changed once formulated unless an appeal is made to and is favorably acted upon by the Commission.
- Plagioglypta** Pilsbry and Sharp, 1897, p. xxxi. Genotype: (by original designation) *Dentalium undulatum* Muenster, in Goldfuss, 1844, p. 3, pl. 166, fig. 8. Triassic, St. Cassian, Tyrol mountains.
- Prodentalium** Young, 1942, p. 120. Genotype: (by original designation) *Prodentalium raymondii* Young, 1942, p. 120, pl. 20, figs. 3-6, 8, 12. Pennsylvanian, Magdalena group, New Mexico.
- Pseudantalis** Monterosato, 1884, p. 32, for *Dentalium fissura* Lamarek, 1818, *D. inversum* Deshayes, 1825, *D. rubescens* Deshayes, 1825, *D. tenuifissa* Monterosato, 1884, *D. filum* Sowerby, 1860. Genotype: (by subsequent designation, Sacco, 1897, p. 111) *Pseudantalis rubescens* (Deshayes), 1825, p. 363, pl. 16, figs. 23-25; Pilsbry and Sharp, 1897, p. 105, pl. 19, fig. 2. Recent, Mediterranean Sea; Pliocene of Italy.
- Schizodontalium** Sowerby, 1894, p. 158. Genotype: (by monotypy) *Schizodontalium plurifissuratum* Sowerby, 1894, p. 158, pl. 12, fig. 24; Pilsbry and Sharp, 1897, p. 82, pl. 6, figs. 87-89. Recent, "Hong Kong?"
- Rhabdus** Pilsbury and Sharp, 1897, p. 112. Genotype: (by original designation) *Dentalium rectius* Carpenter, 1865, p. 59; Pilsbry and Sharp, 1897, p. 113, pl. 21, fig. 45. Recent, Eastern North Pacific Ocean.
- Tesseracme** Pilsbry and Sharp, 1898, p. 249, for "group of *D. quadrapicale*" = *Dentalium dispar* Sowerby, 1860, *D. quadricostatum* Brazier, 1877, *D. dipsycha* Pilsbry and Sharp, 1897, *D. quadrapicale* Sowerby, 1860, *D. tessragonum* Sowerby, 1832, *D. quadrangulare* Sowerby, 1832, *D. fisheri* Pilsbry and Sharp, 1897. Genotype: (by subsequent designation: Woodring, 1925, p. 119) *Dentalium quadrapicale* Sowerby, 1860, p. 103, pl. 225, fig. 61; Pilsbry and Sharp, 1897, p. 34, fig. 50. Recent, Cochin and Malabar, Eastern seas.

## SIPHONODONTALIIDAE

- Cadulus** Philippi, 1844, p. 209. Genotype: (by monotypy) *Dentalium ovulum* Philippi, 1844, p. 208, pl. 27, fig. 21; Pilsbry and Sharp, 1898, p. 157, pl. 32, figs. 40-41. Recent, southern Italy; Pliocene of Calabria and Sicily; Miocene of Piedmont, Italy.
- Cadulus* Jaekel, 1932, p. 311, (caption for text fig. 9). Error for *Cadulus* Philippi, 1844.
- Compressidens** Pilsbry and Sharp, 1897, p. 123. Genotype: (by original designation) *Dentalium pressum* Sharp and Pilsbry, 1897, p. 124, pl. 22, figs. 50-52; new name for *D. compressum* Watson, 1879, p. 516, not D'Orbigny, 1850, p. 233. Recent, Caribbean to off Florida Keys. The taxonomic position of this genus is somewhat uncertain. Though it is generally placed in the family Dentaliidae, a reexamination of the anatomy may necessitate placing it in the Siphonodentaliidae.
- Discides* Pilsbry and Sharp, 1898, p. 253. Error for *Discides* Sacco, 1897.
- Discides* Sacco, 1897, p. 115. Error for *Discides* Jeffreys, 1867.
- Dischides** Jeffreys, 1867, p. 251. Genotype: (by monotypy) *Dentalium bifissum* S. Wood, 1848, p. 190, pl. 20, fig. 3 = *Ditrupa polita* S. Wood, 1842, p. 459, pl. 5, fig. 14; Pilsbry and Sharp, 1898, p. 144, pl. 27, figs. 90-94. Recent, Mediterranean and Eastern Atlantic; Pliocene of England and Italy. The designation of the type might possibly be interpreted as being by original designation as Jeffreys, 1867, states, "*D. bifissum* Searles Wood, from the Coralline Crag, is possibly of the type of another genus, for which I would suggest the name of *Dischides*."
- Entalina** Monterosato, 1872, p. 27, for "*Dentalium ?tetragonum*, Brocc." = "*D. quinquangulare*, Forbes." Genotype: (by subsequent designation, Sacco, 1897, p. 114) *Entalina tetragona* (Brocchi), 1814, p. 627, pl. 15, fig. 26; Pilsbry and Sharp, 1898, p. 234, Miocene of northern Italy and Vienna Basin.
- Gadilia** Gray, 1847, p. 159, no. 280. Genotype: (by original designation) *Dentalium gadus* Montagu, 1803, p. 496, pl. 14, fig. 7; Pilsbry and Sharp, p. 186, pl. 31, figs. 28-32. Recent, British Channel, *vide* Montagu, 1803.
- Gadiopsis** Woodring, 1925, p. 206. Genotype: (by original designation) *Ditrupa dentalina* Guppy, 1873, p. 87, pl. 1, fig. 11; Pilsbry and Sharp, 1898, p. 190, pl. 36, figs. 21-22. Miocene of Jamaica.
- Gadus** "Rang" Deshayes, 1861 ("1864"), p. 217, for *Gadus parisiensis* Deshayes, 1861, *G. bilabiatus* Desh., 1861, *G. brevis* Desh., 1861. Not *Gadus* of Rang, 1829, p. 498, nor of Linné, 1758, pp. 242, 251. Deshayes, 1861, incorrectly assigned three "new" species from the Paris Basin to the pteropod genus *Gadus* of Rang, 1829; *Gadus* of Linné, 1758, a fish genus, is the first valid use of the name. Conrad, 1866, p. 75, used "*Gadus*, Montagu? Rang, 1829" for *Dentalium clavatum* Gould, 1859, *D. pusillum* Gabb, 1864, *D. subcoarctata* [sic] (Gabb), 1860, and *D. thallus* Conrad, 1834, considering *Helonyx* of Stimpson, 1865, a synonym.
- Helonyx** Stimpson, 1865, p. 63. Genotype: (by original designation) *Dentalium clavatum* Gould, 1859, p. 166; Stimpson, 1865, p. 63, pl. 9, fig. 14. Recent, Western Pacific, "Hong Kong."
- Loxoporus** Jeffreys, 1883, p. 664. Genotype: (by monotypy) *Cadulus olivi* (Scacchi), 1835, p. 56, pl. 2, fig. 6, a, b; Pilsbry and Sharp, 1898, p. 170, pl. 31, figs. 33-35. Pliocene of southern Italy and Sicily.
- Platyschides** Henderson, 1920, p. 104. Genotype: (by original designation) *Cadulus grandis* Verrill, 1884, p. 219, pl. 44, fig. 20; Pilsbry and Sharp, 1898, p. 154, pl. 25, fig. 66. Recent, Western Atlantic, north of Cape Hatteras.
- Polyschides** Pilsbry and Sharp, 1898, pp. 142, 146. Genotype: (by original designation, p. 146) *Cadulus (Polyschides) tetraschistus* Watson, 1879, p. 521; Watson, 1885, p. 15, pl. 2, fig. 8. Recent, off Fernando Noronha, Brazil.
- Pulsellum** Stoliczka, 1868, p. 441, for *Siphonodentalium lofotense* M. Sars, 1865, *S. affine* M. Sars, 1865, *S. pentagonum* M. Sars, 1865. Genotype: (by subsequent designation, Cossmann, 1888, p. 11) *Pulsellum lofotense* (M. Sars), 1865, p. 297, pl. 6, figs. 29-33; Pilsbry and Sharp, 1897, p. 138, pl. 24, figs. 40-44. Recent, North Eastern Atlantic, Mediterranean and Aegean Seas; Pliocene of Calabria and Sicily.
- Siphodontalis* Paelte, 1888, p. 565. Error for *Siphontalis* G. O. Sars, 1878, p. 104.
- Siphodontalium* Monterosato, 1874, p. 258. An invalid emendation of *Siphonodentalium* M. Sars, 1859. Other authors, including: Jeffreys, 1877, p. 155 (and later papers), and Watson, 1879, p. 519 (and later papers), have followed Monterosato in using this emendation.
- Siphontalis** G. O. Sars, 1878, p. 104, for *Siphontalis lofotensis* (M. Sars), 1865, *S. affinis* (M. Sars), 1865, *S. tetragona* "Brocchi" G. O. Sars = *Dentalium quinquangulare* Forbes, 1844, a member of the genus *Entalina* of Monterosato, 1872. Genotype: (here designated) *Siphonodentalium lofotense* M. Sars, 1865, p. 297, pl. 6, figs. 29-33; Pilsbry and Sharp, 1897, p. 138, pl. 24, figs. 40-44. Recent, North Eastern



- Atlantic, Mediterranean and Aegean Seas; Pliocene of Calabria and Sicily. As a result of the above designation of *Siphonodentalium lofotense* as genotype, *Siphonentalis* becomes a junior objective synonym of *Pulsellum* Stoliczka, 1868.
- Siphonodentalis* Clessin, 1896, p. 30. Error for *Siphonentalis* G. O. Sars, 1878, p. 104.
- Siphonodentalium** M. Sars, 1859, p. 52. Genotype: (by monotypy) *Siphonodentalium vitreum* (M. Sars) = *D. vitreum* M. Sars, 1851, p. 178, (not Gmelin, 1791, p. 3739), = *Siphonodentalium lobatum* (Sowerby), 1860, p. 100, pl. 225, fig. 44. Recent, North Atlantic.
- Siphonodontum* Locard, 1887, p. 149 (contained in footnote). An invalid emendation of *Siphonodentalium* M. Sars, 1865, p. 296 = *Siphonodentalium* M. Sars, 1859, p. 52.
- Tubidentalium* Locard, 1887, p. 149, (contained in footnote). An invalid emendation of *Siphonodentalium* M. Sars, 1865, p. 296 = *Siphonodentalium* M. Sars, 1859, p. 52.
- #### LITERATURE CITED
- ADAMS, H. and A. *The genera of Recent Mollusca* 1 (vi): 484 pp. London, 1854.
- ALDROVANDI, U. *De reliquis animalibus exanguibus* 593 pp. Bononiae, 1606 (1618).
- BOISSEVAIN, MARIA. *Scaphopoda of the Siboga Expedition* . . . monogr. 54, *Siboga-Expedition*: 75 pp., 6 pls. London, 1906.
- BRAZIER, J. *Mollusca collected during the Chevert Expedition*. Proc. Linn. Soc. New South Wales **2**: 41-70. 1877.
- BROCCHI, G. B. *Conchiologia fossile subappennina con osservazione geologiche*: 2 vols., Milano, 1814.
- BRODERIP, W., and SOWERBY, G. B., I. *Observations on new or interesting Mollusca*. Zool. Journ. London **4**: 369-379. 1829.
- BUSH, K. J. *Additions to the shallow-water Mollusca of Cape Hatteras*. Trans. Conn. Acad. Arts and Sci. **6**: 453-480, pl. 45. 1885.
- CARPENTER, P. P. *Diagnoses specierum . . . molluscorum, prope sinum pegetianum*. Proc. Acad. Nat. Sci. Philadelphia **17**: 54-64. 1865.
- CHENU, J. *Illustrations conchyliologiques* . . . 4 vols. Paris, 1843-53.
- CLESSIN, S. *Die Familie Dentaliidae, systematisches Conchylien-Cabinet* **6** (5): 1-48, pls. 1-11. Nürnberg, 1896.
- CONRAD, T. A. *Descriptions of new species of fossil and Recent shells and corals*. Proc. Acad. Nat. Sci. Philadelphia **3**: 19-27. 1846.
- . *Note on the genus Gadus, with descriptions of some new genera*. Amer. Journ. Conch. **2**: 75-78. 1866.
- COSSMANN, M. *Catalogue illustré des coquilles fossiles de l'Éocène des environs de Paris*. Ann. Soc. Roy. Malac. Belgique **23**: 3-324. 1888.
- COSSMANN, M., and PEYROT, A. *Conchologie néogénique de l'Aquitaine. Scaphopodes*. Bordeaux Actes Soc. Linn. **69**: 157-186, pls. 1-2. "1915," 1916.
- COTTON, B. C., and GODFREY, F. K. *South Australian shells, pt. 8*. South Australian Nat. **14**: (4): 135-150, pl. 1. 1933.
- COTTON, B. C., and LUDDBROOK, N. H. *Recent and fossil species of the scaphopod genus Dentalium in southern Australia*. Trans. Roy. Soc. South Australia **62** (2): 217-228, pl. 12. 1938.
- DA COSTA, E. M. *Historia naturalis testaceorum Britanniae*: 254 pp., 17 pls. London, 1778.
- DALL, W. H. *Reports on the results of the dredging . . . in the Gulf of Mexico . . . by the U. S. Coast Survey steamer Blake*. Bull. Mus. Comp. Zool. **9**: 3-138. 1881.
- DEFRANCE, M. J. L. *In Dictionnaire des Sciences Naturelles* **13**: 578 pp. Strasbourg. 1819.
- DESHAYES, G. P. *Anatomie et monographie du genre Dentale*. Mem. Soc. Hist. Nat. Paris **2**: 324-378, pls. 15-17. 1825.
- . *Description des animaux sans vertèbres découverts dans le Bassin de Paris 2* ("1864"): 195-220, pls. 1-3.
- EMERSON, W. K. *Nomenclatural notes on the Scaphopoda: The subgenus Dentale Da Costa*. Nautilus **65** (1): 17-20. 1951.
- . *Antalis Herrmannsen vs. H. and A. Adams*. Nautilus **66** (1): 1952.
- FISCHER, P. H. *Manuel de conchyliologie et de paléontologie conchyliologique* . . . : xxiv, 1369, 24 pls., text figs. Paris. 1880-97 (1885).
- FORBES, E. *A history of British starfishes* . . . : xx, 267, text figs. London. 1840-41 (1841).
- . *Report on the Mollusca and Radiata of the Aegean Sea*. . . Rep. Brit. Assoc. Adv. Sci. for 1843: 130-193. 1844.
- FORESTI, L. *Dei brachiopodi e dei molluschi paleocenici dei dintorni di Bologna*. Bull. Soc. Malac. Italiana **19** ("1894"): 240-262. Pisa, 1895.
- GAULTIERI, N. *Index testarum conchiliorum* . . . : 5 pts., pp. xxiii, 110 pls. Florentiae, 1688-1747.
- GMELIN, J. F. *In C. Linné, Systema naturae*, ed. 13, **3**. Lipsiae, 1791-93.
- GOULD, A. A. *Descriptions of shells collected by the North Pacific Exploring Expedition*. Proc. Boston Soc. Nat. Hist. **7**: 161-166. 1859.
- GRAY, J. E. *A list of the genera of Recent Mollusca, their synonyma and types*. Proc. Zool. Soc. London for 1847 (pt. 15): 129-219. 1847.
- GREGER, D. K. *Throopella typa, a new Devonian scaphopod*. Geol. Mag. London **70** (830): pp. 373-374, pl. 21, figs. 1-7. 1933.
- GUETTARD, J. E. *Mémoires sur différentes parties des sciences et arts*: 5 vols., illus. Paris, 1768-83, (1770).
- GUILDING, L. *Observations on Naticina and Dentalium, two genera of molluscos animals*. Trans. Linn. Soc. London **17** (1): 29-35, pl. 3. 1834.
- GUPPY, R. J. *On some new Tertiary fossils from Jamaica*. Proc. Sci. Assoc. Trinidad **2** (2), pt. 10: 72-88, pls. 1-3. 1873.
- HENDERSON, J. B. *A monograph of the East American scaphopod mollusks*. U. S. Nat. Mus. Bull. **111**: 177 pp., 20 pls. 1920.
- HERRMANNSEN, A. N. *Indicis generum malacozoorum*: 2 vols., suppl. 1846-49.

- JAECKEL, S. *Nachtrag zu den Scaphopoden der Valdivia-Exped.* Wissenschaftliche Ergebnisse der Deutschen Tiefsee-Exped. **21** (2): 302-315, 11 figs., Jena, 1932.
- JEFFREYS, J. G. *Fourth report on dredging among the Shetland Isles.* Ann. Mag. Nat. Hist. (3) **20**: 247-255. 1867.
- . *New and peculiar Mollusca of the order Solenoconchia procured in the Valorous Expedition.* Ann. Mag. Nat. Hist. (4) **19**: 153-158. 1877.
- . *On the Mollusca procured during the Lighting and Porcupine Expeditions, 1868-70, pt. 5.* Proc. Zool. Soc. London for 1882: 656-687, pls. 49-50. 1883.
- KROTOW, P. *Die Artinskische Etage, Geologisch-Palaeontologische Monographie des Sandsteines von Artinsk* (German summary). Trudy Obshchestva estestvoispytatelei, Kazanslom Univ. **13** (5): 1-314, pls. 1-4. 1885.
- LAMARCK, J. P. *Animaux sans vertèbres* **5**: 341-346. Paris, 1818.
- LINNAEUS, CAROLI [Linné]. *Systema naturae*, ed. **10**, **1**: 824 pp. 1758.
- . *Idem*, ed. **12**, **1** (1): 1106-1269. Holmiae, 1767.
- LOCARD, A. *Prodrome de malacologie Française.* Ann. Soc. Agr. Lyon (5) for 1886 (9): 1-320. 1887.
- MEUNIER, M. *Contributions paléontologiques.* Compt. Rend. Acad. Sci. Paris **86**: 122-124. 1878.
- MONTAGU, G. *Testacea Britannica . . .*: 606 pp., 29 pls. London, 1803.
- MONTEROSATO, T. A., *Notizie intorno alle conchiglie fossili di Monte Pellegrino e Ficarazzi*: 44 pp. Palermo, 1872.
- . *Recherches conchyliologiques, effectuées au cap Santo Vito, en Sicile.* Journ. Conchyl. Paris (3) **22**: 243-284. 1874.
- . *Nomenclatura generica e specifica di alcune conchiglie Mediterranee*, 152 pp. Palermo, 1884.
- MONTFORT, DENYS DE. *Conchyliologie systématique . . .* **2**: 676 pp. Paris, 1810.
- MUENSTER, G. G. *In G. A. GOLDFUSS, Petrefacta Germaniae* **3** (8): iv, 128 pp. pls. 166-200. Leipzig, 1844.
- NEWTON, R. B., and HARRIS, G. B. *A revision of the British Eocene Scaphopoda.* Proc. Malac. Soc. London **1** (2): 63-69, pl. 6, 1894.
- NOSZKY, J. *Die Molluskenfauna des Oberen Catiens von Eger in Ungar.* Ann. Mus. Nat. Hungarici **20**: 53-115, pls. 5, 6. 1936.
- D'ORBIGNY, A. *Prodrome de paléontologie . . .* **2** vols. Paris, 1850.
- PAETEL, F. *Catalog der Conchylien-Sammlung, mit Hinzufügung der bis jetzt publicirten recenten Arten, sowie der ermittelten Synonyma*, ed. **4**, **1**: 639 pp. Berlin, 1887, 1888.
- PERRY, G. *Conchology*: 4 pp., 61 pls. London, 1811.
- PHILIPPI, R. A. *Enumeratio molluscorum Siciliae . . .* **2**: 207-233. Berlin, 1844.
- PILSBRY, H. A., and SHARP, B. *In G. W. TRYON, Manual of conchology* (1) 17 (pt. 65): 1-80, May 1897; pt. 66: 81-144, Oct. 15, 1897; pt. 67: 145-224, May 3, 1898; pt. 68: 225-348, pls. 1-32, Dec. 7, 1898. Philadelphia, 1897-98.
- RANG, M. *Description de cinq espèces de coquilles fossiles appartenant à la classe des Pétropodes.* Ann. Sci. Nat. Paris **13**: 492-499, pl. 19. 1829.
- ROVERETO, G. *Illustrazione dei molluschi fossili tongriani posseduti dal Museo Geologico della R. Univ. di Genova.* Atti Univ. Genova **15**: 1-210, pls. 1-9. 1900.
- SACCO, F. *I molluschi dei terreni terziarii del Piemonte e della Liguria.* Boll. Mus. Zool. Anat. Com. R. Univ. Torino **11** (267): 79-98. 1896.
- . *I molluschi dei terreni terziarii del Piemonte e della Liguria*, pt. 22: 1-118, pls. 1-10. Torino, 1897.
- SARS, G. O. *Bidrag til Kundskaben om Norges Arktiske Fauna, I Mollusca Regionis Arcticae Norvegiae.* Universitetsprogram for 1878: xiii, 466 pp., 34 pls. Christiania, 1878.
- SARS, MICHAEL. *Beretning om en i Sommeren 1849 foretagen Zoologisk Reise i Lofoten og Finmarken.* Nyt. Mag. Naturv. **6**: 121-211. Christiania, 1851.
- . *Bidrag til en Skildring af den arktiske Mollusfauna ved Norges nordige Kyst.* Forh. Vid.-Selsk. for 1858: 34-87. Christiania, 1859.
- . *Malacozoologische Iagttagelser, II, Nye Arter af Slaegten Siphonodentalium.* Forh. Vid.-Selsk. for 1864: 296-315, pls. 6-7. 1865.
- . *Om Siphonodentalium vitreum, en ny slaegt og art af Dentalidernes Familie.* Universitets-Program: 1-29, pls. 1-3. Christiania, 1861.
- SCACCHI, A. *Notizie intorno alle conchiglie ed a'zoo-fiti fossili che si Trovano nelle vicinanze di Gravini in Puglia.* Ann. Civ. Reg. Sicile **7**: 23-32. 1835.
- SCHLOTHEIM, E. *Taschenbuch für die gesammte Mineralogie . . .* **7** (1): 1-312, 7 pls. Frankfurt, 1813.
- SCHROETER, J. S. *Einleitung in die Conchylien Kenntniss nach Linné* **2**: viii, 726 pp. Halle, 1784.
- SIMROTH, H. *In H. G. Bronn, Klassen und Ordnungen des Thiere-Reichs . . .*, I, *Amphineura und Scaphopoda*: 354-467. 1894-95.
- SOWERBY, G. B., I. *Genera of Recent shells, Dentalium*: fig. 5. London, 1823.
- . [New shells.] Proc. Comm. Sci. and Corres. Zool. Soc. London, for 1832: 25-33. 1832.
- SOWERBY, G. B., II. *A conchological manual*: v, 130 pp., 24 pls. London, 1839.
- . *Monograph of the genus Dentalium. Thesaurus Conchyliorum* **3**: 97-104, pls. 223-225. London, 1860.
- SOWERBY, G. B., III. *Descriptions of new species of marine shells from the neighbourhood of Hong-Kong.* Proc. Malac. Soc. London **1** (4): 153-162. 1894.
- STIMPSON, W. *On certain genera and families of zoophagous gasteropods.* Amer. Journ. Conch. **1**: 55-64, pls. 8-9, 1865.
- STOLICZKA, F. *The Gastropoda of the Cretaceous rocks of southern India.* Mem. Geol. Surv.

- India, *Palaeontologica Indica* (5) 2: xiii, 497, 33 pls. Calcutta, 1868.
- SUTER, H. *Manual of New Zealand Mollusca*: xxiii, 1120 pp., figs. 1913.
- TURTON, W. *A conchological dictionary of the British Islands*: xxii, 272 pp., 28 pls. London, 1819.
- VERRILL, A. E. *Second catalogue of Mollusca recently added to the fauna of the New England coast*. *Trans. Conn. Acad. Arts and Sci.* 6: 141-294, pls. 28-32. 1884.
- WATSON, R. B. *Mollusca, H. M. S. Challenger Expedition*, pt. 1. *Journ. Linn. Soc. London* 14: 505-529. 1879.
- . *Report on the Scaphopoda and Gastropoda collected by the H. M. S. Challenger*. . . *Rept. Sci. Res. Voy. H. M. S. Challenger, Zool.*, 15: pt. 42: 756 pp., 53 pls. London, 1886.
- WOOD, S. V. *A catalogue of shells from the Crag*. *Ann. Mag. Nat. Hist.* (1) 9: 455-462, pl. 5. 1842.
- . *A monograph of the Crag Mollusca*: 208 pp., 28 pls. *Paleont. Soc. London*, 1848.
- WOODRING, W. P. *Marine mollusks from Bowden Jamaica: Pelecypods, scaphopods*. *Carnegie Inst. Washington Publ.* 366: 222 pp., 28 pls. 1925.
- YOUNG, J. A. *Pennsylvanian Scaphopoda and Cephalopoda from New Mexico*. *Journ. Paleont.* 16 (1): 120-125, pl. 20, 2 figs. 1942.

NEMATOTOLOGY.—*The teasel nematode, Ditylenchus dipsaci (Kühn, 1857), Filipjev, 1936.* WILBUR D. COURTNEY, Bureau of Plant Industry, Soils, and Agricultural Engineering. (Communicated by G. Steiner.)

Textile mills have long depended on the spiny heads or "burs" of cultivated teasel plants to produce the nap on fine woolens. Other materials have been tested for this use, but only nylon bristles have shown promise of success. Teasel culture constitutes an agricultural crop of extreme geographical limitations with the principal American planting being located in the Pacific Northwest.

The teasel is a biennial with a rosette of stout, coarse leaves attached to a fleshy crown during its first year. In late spring of the second year, a main stem with side branches rapidly grows or "runs" to a height of 4 to 7 feet and bears a spiny head at each terminal. When these heads are in the correct stage of development they are removed from the plant together with some 8 inches of stem. This is a hand operation, since the heads mature at three or four different times, depending on the part of the plant to which they may be attached. The harvested heads are placed in large, aerated sheds to cure, after which the salables are trimmed, graded to size and shipped to various textile mills. These teasel heads must be of uniform cylindrical shape and bear strongly attached spines in order to serve their purpose in finishing fine woolens.

The production of "puff balls" instead of sound heads, and the failure of second year plants to produce heads have resulted in various degrees of losses due to nematode infection. These losses have ranged from a

trace, in a number of cases, to complete destruction, in a few isolated fields.

The bulb and stem nematode, *Ditylenchus dipsaci*, was first described by Kühn (2) in 1857 as the cause of "Kernfäule" of the inflorescence in fullers teasel, *Dipsacus fullonum* L. His description of the symptoms of nematode infection in teasels was confined to the characteristic misshapen, "soft shelled" heads or puff balls instead of the normal burs. Later, Ritzema Bos (3) reported negative results in his attempts to transfer the rye, onion and hyacinth populations of the bulb and stem nematode to teasel seedlings. His work was restricted since he had never observed nematode infection of teasel plants. These early investigations were quoted by later workers and little in addition was accomplished until Thorne (4) in 1945 illustrated and amended the diagnosis of the teasel nematode from the Pacific Northwest.

SYMPTOMS OF NEMATODE INFECTION

Bulb and stem nematodes usually enter teasel plants in the young seedling stage during prolonged moist conditions. They feed and reproduce in the young crowns and leaves, causing large populations to be built up under favorable circumstances. When the bud for the central shoot develops from an infected crown during the second year many nematodes attack the tissue surrounding the growing point, reproduce rapidly and are carried upward by plant

growth. They are present, therefore, when the growing points terminate in developing teasel heads or burs. The woody, vascular bundles surrounding the pith in the teasel head are so weakened by this infection that

the bur gradually widens to a more or less spherical soft-walled mass. As the puff ball matures and becomes dry the nematodes collect in whitish masses in and near the pith as well as becoming attached to the

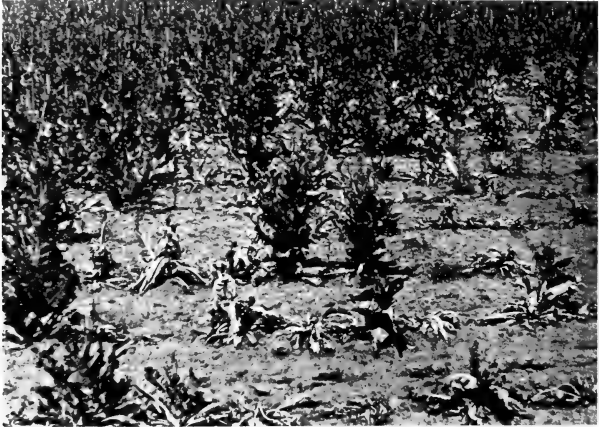

FIG. 1.—Teasel field showing severe nematode infection.



FIG. 2.—Close-up view of teasel plants, with their crowns cut open. Normal plant on right and infected plant on left. The pressure of cutting caused the weakened crown to break into the four sections.

pedicel of each seed. These nematode masses and those attached to the seed enter a quiescent stage in which they can live for at least 23 years, if kept dry, according to Fielding (1). Upon becoming moist the nematodes revive and may remain active for a year or two in moist soil without their host plant.

First year plants which are lightly infected may apparently grow well and give little indication of their weakened crowns. Moderately infected plants may survive during favorable seasons but are too weak to withstand poor growing conditions. Heavily infected plants develop leaves with discolored areas along their midribs, are often unduly curled and gradually die. In such cases the infection is chiefly concentrated in the crown, the tissue of which becomes discolored and progressively necrotic until, in last stages, only a tangled mass of vascular bundles remains within the crown covering. The discolored and distorted tissues contain all stages of these nematodes.

Second year plants which are lightly infected may appear normal with the exception of a few soft malformed heads. Moder-

ately infected plants may be considerably dwarfed, produce puff balls instead of normal heads and often die prematurely.

#### TRANSFER OF TEASEL NEMATODE TO OTHER PLANTS

Studies of transfer of the present nematode from teasels to other plants were prompted by the finding of a few areas of infestation in a field of teasels which had not produced this crop for more than 10 years. As the teasel seed used for planting had been hot-water treated and was therefore nematode free, it appeared that the infestation had remained in the soil for that period of time, especially since no obvious method of spread could be determined. The following weeds growing on these areas were examined for nematode infection, with the results shown in Table 1.

As noted above, the only weeds having a nematode infection were the large-flowered collomia and the buckhorn plantain. No symptoms, however, were found in either of these plants. The plantain contained only limited numbers of preadult nematodes and very young adult forms, while considerable numbers of nematodes in all stages of

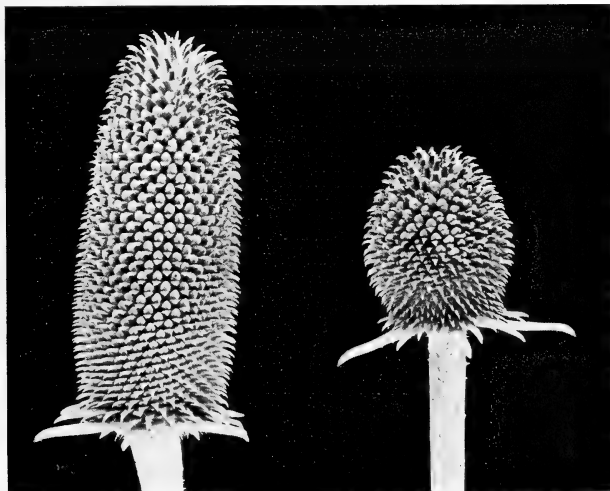

FIG. 3.—Teasel heads, normal on left and infected (puff ball) on right.

TABLE 1.—NUMBER OF INFECTED WEED PLANTS GROWING IN SOIL INFESTED WITH THE TEASEL NEMATODE

Plant	Total plants examined	Plants infected
Amaranth, redroot ( <i>Amaranthus retroflexus</i> L.)	12	0
Bent grass, redtop ( <i>Agrostis alba</i> L.)	4	0
Camomile, mayweed ( <i>Anthemis cotula</i> L.)	20	0
Catsear, spotted ( <i>Hypochoeris radicata</i> L.)	20	0
Collomia, large-flowered ( <i>Collomia grandiflora</i> Dougl.)	35	20
Dandelion ( <i>Taraxacum officinale</i> L.)	16	0
Dock, curly ( <i>Rumex crispus</i> L.)	5	0
Fern, bracken ( <i>Pteridium aquilinum pubescens</i> Underw.)	13	0
Fleabane, horseweed ( <i>Erigeron canadensis</i> L.)	10	0
Gilia, skunkweed ( <i>Gilia squarrosa</i> H. and A.)	5	0
Goosefoot, lambsquarters ( <i>Chenopodium album</i> L.)	9	0
Knotweed, prostrate ( <i>Polygonum aviculare</i> L.)	4	0
Lettuce, prickly ( <i>Lactuca serriola</i> L.)	9	0
Plantain, buckhorn ( <i>Plantago lanceolata</i> L.)	40	3
Radish, wild ( <i>Raphanus raphanistrum</i> L.)	10	0
Ryegrass, Italian ( <i>Lolium multiflorum</i> Lam.)	18	0
Salsify, meadow ( <i>Tragopogon pratensis</i> L.)	10	0
Shepherdspurse ( <i>Capsella bursa-pastoris</i> (L.) Moench)	3	0
Sorrel, sheep ( <i>Rumex acetosella</i> L.)	20	0
Southistle, common ( <i>Sonchus oleraceus</i> L.)	5	0
Thistle, bull ( <i>Cirsium lanceolatum</i> (L.) Scop.)	14	0
Total	282	23

TABLE 2.—NUMBER OF INFECTED CROP PLANTS GROWING IN SOIL INFESTED WITH THE TEASEL NEMATODE AND IN GREENHOUSE TESTS WITH INOCULUM FROM OATS

Crop plant	Field Grown		Greenhouse Grown
	Spring	Winter	
	15 plants of each variety examined	48 plants of each variety examined	20 plants of each variety examined
Barley ( <i>Hordeum vulgare</i> L.)	0	0	0
Clover, Hubam ( <i>Melilotus alba</i> var. <i>annua</i> Coe)	0	0	0
Clover, crimson ( <i>Trifolium incarnatum</i> L.)	0	0	0
Clover, red ( <i>Trifolium pratense</i> L.)	0	0	1
Corn ( <i>Zea mays</i> L.)	0	0	0
Oats, spring ( <i>Avena sativa</i> L.)	0	15	6
Oats, winter ( <i>Avena sativa</i> L.)	0	16	13
Peas, field ( <i>Pisum sativum arvense</i> L.)	0	0	0
Rye, Rosen ( <i>Secale cereale</i> L.)	0	0	8
Teasels ( <i>Dipsacus fullonum</i> L.)	0	30	12
Vetch ( <i>Vicia sativa</i> L.)	0	0	0
Wheat, spring ( <i>Triticum aestivum</i> L.)	0	14	14
Wheat, winter ( <i>Triticum aestivum</i> L.)	9	18	11

TABLE 3.—PERCENTAGE OF GERMINATION OF TEASEL SEED TREATED IN WATER AT DIFFERENT TEMPERATURES, DURATIONS, AND CHEMICALS ADDED (GERMINATION TESTS DETERMINED AT SEED LABORATORY, OREGON STATE COLLEGE)

Duration	Temp. °F.	Water	Water + Vatsol <sup>1</sup>	Water + Formalin <sup>2</sup>	Vatsol + Formalin <sup>3</sup>
(Untreated check)		91.6	90.7	93.1	93.2
1 hour	75	89.5	90.2	13.5	32.0
	120	78.5	61.2	40.5	0.0
	122	57.5	46.5	0.0	0.0
2 hour	75	89.5	92.5	6.0	14.7
	120	41.2	40.5	0.0	0.0
	122	12.0	9.7	0.0	0.0

<sup>1</sup> Vatsol O.S. used at rate of 8 oz. in 100 gallons of water.<sup>2</sup> Formaldehyde solution U.S.P. 1 pint in 25 gallons of water.<sup>3</sup> Vatsol and formaldehyde combined at the above rates.

development were usually found in the collomia.

During the early spring of the following year attention was called to the unusual appearance of another field in which winter oats had been planted following an infected teasel crop. The uneven growth in this field showed as prominent spots of dead and dying oat plants. Upon examination these distorted plants resembled the "segging" or "tulip-root" as described by various workers and contained huge numbers of teasel nematodes. This observation indicated that winter oats might also have been serving as a host of the teasel nematode. To test this theory, oat plants infected from this soil were used to inoculate various crop plants growing in sterilized soil in pots in greenhouse tests listed in Table 2.

The same kinds of crop plants used in these greenhouse tests were also planted in a field which had recently produced heavily infected teasels. The weather was warm and dry that spring so that these plants rapidly grew to maturity and showed little infection upon examination. The following autumn they were re-planted on the same soil and slowly grew through the winter, under wet

conditions. Results of the examination of both spring and fall planted crop plants, at their maturity, are presented in Table 2.

The infected crop plants listed above contained bulb and stem nematodes in all stages of development. These data show that several crop plants including oats, red clover, rye and wheat act as carriers of bulb and stem nematodes infecting teasels. It was possible to transfer the disease from winter oats to teasels and it may be that similar transfers could have been made from the other hosts if time and facilities had permitted their study. Evidently plants which grow over winter after autumn seeding are more likely to become infected than fast growing annuals seeded in the spring. This is probably due to the increased opportunity for nematode invasion because of the prolonged seedling stage and wet surroundings of autumn planted seed.

#### CONTROL

There are two chief sources of nematode infection of teasel plants and both are the result of contamination. These two sources are nematodes on the seed used for planting and nematodes remaining in the soil after

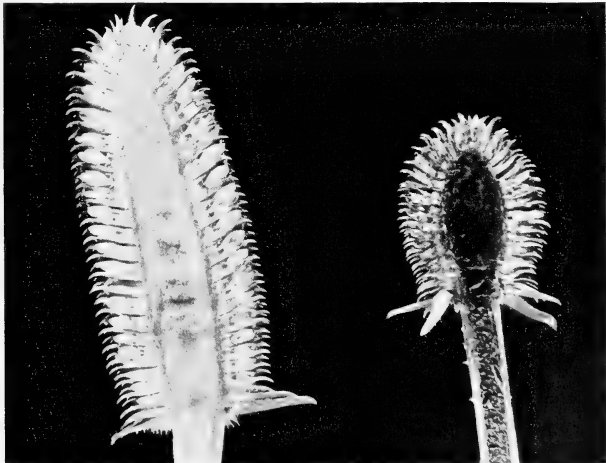

FIG. 4.—Same as FIG. 3 except the heads are cut open. Note the healthy pith in the normal head and discoloration in the infected head.

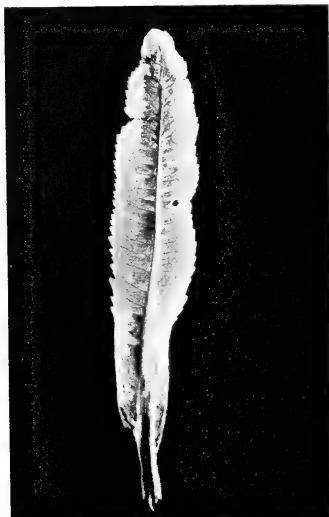

FIG. 5.—Infected teasel leaf. Note discolored areas along midrib.

an infected teasel or other host crop or weed has grown on the field. Control is a matter of eliminating these nematodes, as follows:

1. Teasel seed should be treated in hot water at 122°F. for one hour, or 120°F. for two hours in order to obtain a complete nematode kill. Experiments used in establishing these treatments included the use of formaldehyde solution and a wetting agent (Vatsol O.S.) in the treating bath, as these materials had previously increased the nematode killing power of this bath as used for narcissus bulbs. The germination of teasel seed exposed to these treatments is given in Table 3. In addition to the germination tests, the treated seed was planted in the field and readings were later taken on the early growth, mid-season growth, final stand, and condition of mature teasel heads and spines.

An examination of the above data together with that of criteria mentioned earlier indicated that:

- a. Formaldehyde solution used in the treating water is harmful to the germination

of teasel seed and also to the later growth of the plants.

- b. Vatsol O.S. used in the treating water exerts little influence on the germination of teasel seed or the later growth of the plants.

- c. Teasel seed may be treated at 122°F. for one hour or 120°F. for two hours in water with or without Vatsol. Such treatments reduce the seed germination, however, so that twice as much treated seed must be planted in order to secure normal field stands of teasels. Fortunately this is an unimportant factor, due to the abundance of seed produced by this crop. Teasel plants resulting from treated seed showed increased mid-season growth, more vigorous and upright mature plants with increased number of heads and normal stiffness of spines.

2. Soil can be freed of *D. dipsaci* by rotation with crops which are not host plants, provided it is kept free of weeds, especially in wet seasons.



FIG. 6.—Normal teasel leaf.



Nematode infection of teasel plantings became nearly non-existent as a result of planting hot-water-treated teasel seed on properly managed soil. Fields known to be infested were plowed or disked in the autumn to destroy all growing plants and seeded the following spring to fast growing annuals to be harvested or used as a cover crop. After a 3-year period these fields were relatively free of nematode infestation, providing the residue from the former teasel crop had been properly destroyed.

## SUMMARY

The nematode *Ditylenchus dipsaci* has been recorded as doing extensive damage to teasel crops in the Pacific Northwest, when proper control measures were not used.

Infected teasel plants may be dwarfed in appearance, having leaves with discolored areas along their midribs, later dying. The crown is often discolored and may be rotted to various degrees. Top growth from such crowns may be of normal size, but bear misshapen heads or burs, known as puff balls. In severe cases no top growth is produced.

In a series of tests made, plants which became heavily infected with bulb and stem nematodes from teasels, were large flowered collomia, oats (winter and spring types), rye, and wheat (winter and spring types).

Buckhorn plantain and red clover plants contained a few nematodes, which were unable to reproduce. Corn, crimson clover, Hubam clover and field peas failed to become infected.

Control consists of eliminating the two main sources of infection, namely, the nematodes remaining in the soil after an infected crop has been harvested and those with the seed. Nematodes are eliminated from the soil by rotation with resistant crops, special attention being given to weed control, and from the seed by treatment with hot water.

## LITERATURE CITED

- (1) FIELDING, MAX J. *Observations on the length of dormancy in certain plant infecting nematodes*. Proc. Helminth. Soc. Washington **18** (2): 110-112. 1951.
- (2) KÜHN, JULIUS. *Über das Vorkommen von Anguillulen in erkrankten Blütenköpfen von Dip-sacus fullonum L.* Zeitschr. Wiss. Zool. **9** (1): 129-137. 1857.
- (3) RITZEMA BOS, JAN. *L'Anguillule de la tige (Tylenchus devastatrix Kühn) et las maladies des plantes dues à ce nématode*. Arch. Mus. Teyler (2) **3** (4): 333-348. 1890.
- (4) THORNE, GERALD. *Ditylenchus destructor, n.sp., the potato rot nematode, and Ditylenchus dipsaci (Kühn, 1857) Filipjev, 1936, the teasel nematode (Nematoda: Tylenchidae)*. Proc. Helminth. Soc. Washinton **12** (2): 27-34. 1945.

## NEW MEMBERS OF THE ACADEMY

There follows a list of persons elected to membership in the Academy, by vote of its Board of Managers, since April 1, 1950, who have since qualified as members in accordance with the bylaws (see also this JOURNAL **40**: 302-306, 1950).

## RESIDENT

*Elected April 17, 1950*

Chan-Mou Tchen, physicist, National Bureau of Standards, in recognition of his contributions to the theory of fluid mechanics, especially the application of statistical methods to motion of small particles and chain molecules, and the treatment of flow problems involving heat addition.

*Elected June 18, 1951*

Francis C. Breckenridge, physicist, National Bureau of Standards, in recognition of his contributions to aviation lighting and signal colors, and in particular for the evaluation of approach light systems, the development of a chromaticity diagram and the coordination of signal colors, and for his productive work with the I.E.S. and the I.C.I. in these fields.

Newbern Smith, Central Radio Propagation Laboratory, National Bureau of Standards, in recognition of his contributions to studies of radio propagation and the ionosphere, and their application to problems of radio communication.

*Elected November 19, 1951*

Ernest N. Cory, assistant director, Extension Service; head, Department of Entomology; and State entomologist, University of Maryland, in recognition of his contributions to entomology, in directing research, teaching, and regulatory work of the Department of Entomology at the University of Maryland since 1914; having an important part in the growth of the American Association of Economic Entomologists; having managed the *Journal of Economic Entomology* with a world-wide distribution; having published approximately 200 scientific articles on a wide variety of insects, and having initiated and directed the published works of many associates.

George McMillan Darrow, pomologist, U. S. Department of Agriculture, in recognition of his outstanding contributions to plant breeding and genetics, particularly with respect to the utilization and interpretation of polyploidy in plants.

Carlton M. Herman, game pathologist, Fish and Wildlife Service, U. S. Department of the Interior, in recognition of his contributions to knowledge of parasites of birds and mammals, including bird malaria, and the epidemiology of diseases of wildlife.

Michael J. Pelczar, associate professor, Department of Bacteriology, University of Maryland, in recognition of his research work performed in the field of bacterial physiology and metabolism.

John H. Zeller, in charge of swine investigations, Bureau of Animal Industry, in recognition of his contributions to the science of swine production.

*Elected December 17, 1951*

Richard S. Hunter, optical engineer, Henry A. Gardner Laboratory, in recognition of his contributions to tristimulus photoelectric colorimetry, to the analysis of gloss and its measurement, to the design of apparatus for testing appearance properties of materials.

Philip R. Karr, physicist, National Bureau of Standards, in recognition of his studies of radiation fields and of the penetration and diffusion of X-rays through barriers.

Kathryn Knowlton, biochemist, National Institute of Arthritis and Metabolic Diseases, National Institutes of Health, in recognition of her contributions in research and development of analytical methods for metabolic research.

Louis R. Maxwell, physicist, Naval Ordnance Laboratory, in recognition of his studies on average lifetime in excited states (atomic), electron diffraction of gases and liquids, and magnetic investigations of antiferromagnetic materials.

Norman B. McCullough, chief, Laboratory of Clinical Investigations, National Microbiological Institute, National Institutes of Health, in recognition of his many outstanding contributions to our knowledge of the cause, diagnosis and treatment of brucellosis in man.

Sherman Ross, associate professor of psychology, University of Maryland, in recognition of his contributions to the science of psychology, and in particular his researches on the effects of diet on social behavior.

James A. Shannon, associate director, National Heart Institute, National Institutes of Health, in recognition of his outstanding research particularly in areas of the physiology of excretion and of the pharmacology and chemotherapy of anti-malarial drugs.

Falconer Smith, scientist, U. S. Public Health Service, in recognition of his work on radiation sickness.

Lawrence Zeleny, chief, Standardization Research and Testing Division, U. S. Department of Agriculture, in recognition of his work in the chemistry of fats and oils and cereal chemistry.

*Elected January 14, 1952*

Edith K. Cash, mycologist, Division of Mycology and Disease Survey, U. S. Department of Agriculture, in recognition of her contributions to mycology and in particular her researches on the taxonomy of the *Discomycetes*.

Raymond N. Doetsch, assistant professor of bacteriology, University of Maryland, in recognition of his contributions to general bacteriology with particular emphasis on physiology and dairy bacteriology.

Anna Hietanen-Makela, chief, Petrological Investigations Unit, U. S. Geological Survey, in recognition of her contributions to metamorphism and structural petrology.

Alice Phillips Withrow, plant physiologist, Smithsonian Institution, in recognition of her contributions to radiation physiology.

Robert B. Withrow, chief, Division of Radiation and Organisms, Smithsonian Institution, in recognition of his contributions to radiation physiology.

*Elected February 18, 1952*

Clifford Evans, associate curator of ethnology, U. S. National Museum, in recognition of his contributions to South American archeology, especially the Amazon region.

Thomas J. Killian, science director, Office of Naval Research, in recognition of his contributions to the science of physics, particularly his research on electrical discharges in gases, and his outstanding contributions as an administrator of Navy sponsored basic research.

E. R. Piore, deputy chief and chief scientist, Office of Naval Research, in recognition of his contributions to the science of physics, particularly his work on electron emission, and his outstanding services in the encouragement and administration of basic research.

*Elected March 17, 1952*

L. B. Aldrich, director, Astrophysical Observatory, Smithsonian Institution, in recognition of his ability and accomplishments both as an investigator in astrophysics and as administrator of the Astrophysical Observatory.

Howard L. Andrews, chief, section on Nuclear Radiation Biology, National Institutes of Health, in recognition of his achievements in research on and the teaching of nuclear radiation phenomena in relation to public health and civil defense.

M. Thomas Bartram, chief, Bacteriological Branch, Division of Microbiology, U. S. Food and Drug Administration, in recognition of his work on the bacteriology of foods.

E. P. Cronkite, head, Hematology Division, Naval Medical Research Institute, in recognition of his contributions in use of blood derivatives in clinical medicine, hematologic effects of radiation, hemostasis in normal and irradiated animals, and hematologic and lethal effects of atomic bomb radiation (Bikini and Eniwetok).

R. Harold Draeger, head, Atomic Medical Division, Naval Medical Research Institute, in recognition of his work in the field of atomic medicine, particularly the biological engineering of equipment for the exposure of animals to atomic bomb air blast, thermal and ionizing radiation.

William H. Hoover, chief astrophysicist, Astrophysical Observatory, Smithsonian Institution, in recognition of his ability as a research investigator in physics, astrophysics, and plant physiology.

Richard H. Lee, commander, Allied Science Section of the Medical Service Corps, U. S. Navy, in recognition of his research in night vision and biological aspects of the testing of atomic weapons.

Hui-Lin Li, visiting research scientist, U. S. Department of State, in recognition of his contributions to the botany of Chinese plants, especially his studies of the Scrophulariaceae and of the flora of Formosa.

William D. Reed, entomologist, Department of the Army, Office of the Chief of Engineers, in recognition of his services to the science of entomology in research and administration.

Glenn G. Slocum, chief, Division of Microbiology, Food and Drug Administration, in recognition of his work on the microbiology of foods and drugs.

*Elected April 7, 1952*

Ralph A. Alpher, physicist, Johns Hopkins University Applied Physics Laboratory, in recognition of his contributions to astrophysics, particularly his contributions to theories of the origin of the elements, as well as other work in fluid mechanics and cosmic rays.

Harold J. Coolidge, executive director, Pacific Science Board, National Research Council, in recognition of his researches in mammalogy and his outstanding work in organizing and directing various scientific expeditions and promoting international conservation of wildlife and world extension of national parks and primitive areas; especially for his work in extending international cooperation in Pacific science.

Alden H. Emery, executive secretary, American Chemical Society, in recognition of his contributions to the knowledge of sources of rock strata gases, sources and collection of dust in mines, mineragraphic identification of minerals; microscopic mineralogy, treatment and utilization of nonmetallic minerals, and mineral fillers.

Robert C. Herman, physicist, Johns Hopkins University Applied Physics Laboratory, in recognition of his contributions to molecular physics, solid state physics, and astrophysics, and in particular his work in molecular dynamics, luminescence and photoconductivity, and the origin of the elements.

## NONRESIDENT

*Elected November 19, 1951*

O. Wilford Olsen, head, Department of Zoology, Colorado Agricultural and Mechanical College,

Fort Collins, Colo., in recognition of his investigations on control and therapeutics of parasites of cattle, particularly liver flukes, and parasites of wildlife.

Robert L. Weintraub, supervisory plant phys-

icologist, Camp Detrick, Maryland, in recognition of his research in plant physiology and chemistry, particularly his contributions to the knowledge of plant growth substances and the effect of radiant energy on plants.

## Obituary

JAMES LEE PETERS, curator of birds at the Museum of Comparative Zoology, Harvard University, died in Boston in his 62d year on April 19, 1952, after a rather sudden heart attack complicated by pneumonia. Aside from field trips to various parts of North and South America and to Europe, his entire life was spent in the Boston region, where he was born on August 13, 1889, and his whole scientific career, save for a short service in the field with the old Biological Survey of the Department of Agriculture, was centered in the great museum at Harvard. Following his graduation from Harvard in 1912 he worked without title or salary for a number of years as assistant to the late Outram Bangs, later becoming assistant curator and, on the death of Bangs in 1932, curator of the division of birds.

In the early years of his work at the museum Peters made numerous expeditions, beginning with a trip to Quintana Roo in 1912. Four years later he collected in the northern part of the Dominican Republic. He served with the U. S. Army in France in the first World War, but after the armistice resumed bird work. In 1920 and 1921 he was in Argentina, and particularly in Patagonia, making special observations on the ducks for the late John C. Phillips, but obtained a general collection of the avifauna of the region as well. In 1922 he spent some time on the island of Anguilla, West Indies, and late in 1927 he made the first ornithological survey of the Corn Islands, off the coast of Honduras. From these

islands early in 1928 he went to the Caribbean lowlands of Honduras, where he collected for some three months. This was his last field trip, and while his personal collecting was confined to New World birds, his studies were world-wide. He wrote technical reports on other collections from Asia, Africa, and New Guinea and became deeply interested in nomenclature and classification. This provided the background for his major work, his *Check list of birds of the world*, the first volume of which appeared in 1931, the seventh in 1951. At the time of his death he had much manuscript prepared for the eighth volume and anticipated that the total work would require about 15 volumes. This great work, only partly accomplished, will long remain his monument. Few recent publications are in more constant use by systematic ornithologists the world over than these books, and it is hoped that a way may be found to have the task completed. In 1934 the German Ornithological Society made him a corresponding member because of the excellence of this work, and six years later he was further recognized by the American Ornithologists' Union with their highest award, the Brewster Medal. He was president of this society from 1942 to 1945.

His interest in questions of nomenclature led him eventually to the presidency of the International Commission of Zoological Nomenclature, which position he held at the time of his death. His passing leaves a gap it will be difficult to fill.

HERBERT FRIEDMANN.

## Officers of the Washington Academy of Sciences

*President*.....WALTER RAMBERG, National Bureau of Standards  
*President-elect*.....F. M. SETZLER, U. S. National Museum  
*Secretary*.....F. M. DEFANDORF, National Bureau of Standards  
*Treasurer*.....HOWARD S. RAPPELEYE, U. S. Coast and Geodetic Survey  
*Archivist*.....JOHN A. STEVENSON, Plant Industry Station  
*Custodian and Subscription Manager of Publications*  
 HARALD A. REHDER, U. S. National Museum

*Vice-presidents Representing the Affiliated Societies:*

Philosophical Society of Washington.....A. G. McNISH  
 Anthropological Society of Washington.....WALDO R. WEDEL  
 Biological Society of Washington.....HUGH T. O'NEILL  
 Chemical Society of Washington.....JOHN K. TAYLOR  
 Entomological Society of Washington.....FREDERICK W. POOS  
 National Geographic Society.....ALEXANDER WETMORE  
 Geological Society of Washington.....A. NELSON SAYRE  
 Medical Society of the District of Columbia.....FRED O. COE  
 Columbia Historical Society.....GILBERT GROSVENOR  
 Botanical Society of Washington.....LEE M. HUTCHINS  
 Washington Section, Society of American Foresters.....WILLIAM A. DAYTON  
 Washington Society of Engineers.....CLIFFORD A. BETTS  
 Washington Section, American Institute of Electrical Engineers.....A. H. SCOTT  
 Washington Section, American Society of Mechanical Engineers.....RICHARD S. DILL  
 Helminthological Society of Washington.....L. A. SPINDLER  
 Washington Branch, Society of American Bacteriologists.....ANGUS M. GRIFFIN  
 Washington Post, Society of American Military Engineers.....FLOYD W. HOUGH  
 Washington Section, Institute of Radio Engineers.....HERBERT G. DORSEY  
 District of Columbia Section, American Society of Civil Engineers  
 MARTIN A. MASON  
 District of Columbia Section, Society for Experimental Biology and Medicine  
 N. R. ELLIS

*Elected Members of the Board of Managers:*

To January 1953.....C. F. W. MUESEBECK, A. T. MCPHERSON  
 To January 1954.....SARA E. BRANHAM, MILTON HARRIS  
 To January 1955.....ROGER G. BATES, W. W. DIEHL

*Board of Managers*.....All the above officers plus the Senior Editor  
*Board of Editors and Associate Editors*.....[See front cover]

*Executive Committee*.....WALTER RAMBERG (chairman), F. M. SETZLER, H. S. RAPPELEYE,  
 WILLIAM A. DAYTON, F. M. DEFANDORF  
*Committee on Membership*.....E. H. WALKER (chairman), M. S. ANDERSON, CLARENCE COT-  
 TAM, R. C. DUNCAN, JOHN FABER, G. T. FAUST, I. B. HANSEN, FRANK KRACEK, D. B.  
 JONES, E. G. REINHARD, REECE I. SAILER, LEO A. SHINN, F. A. SMITH, HEINZ SPECHT,  
 H. M. TRENT, ALFRED WEISSLER

*Committee on Meetings*.....H. W. WELLS (chairman), WM. R. CAMPBELL, W. R. CHAP-  
 LINE, D. J. DAVIS, H. G. DORSEY, O. W. TORRESON

*Committee on Monographs* (W. N. FENTON, chairman):  
 To January 1953.....R. W. IMLAY, P. W. OMAN  
 To January 1954.....S. F. BLAKE, F. C. KRACEK  
 To January 1955.....W. N. FENTON, ALAN STONE

*Committee on Awards for Scientific Achievement* (J. R. SWALLEN, general chairman):  
*For Biological Sciences*.....J. R. SWALLEN (chairman), L. M. HUTCHINS,  
 MARGARET PITTMAN, F. W. POOS, L. P. SCHULTZ  
*For Engineering Sciences*.....R. C. DUNCAN (chairman), A. C. FIELDNER,  
 WAYNE C. HALL, J. W. MCBURNEY, O. S. READING, H. L. WHITTEMORE  
*For Physical Sciences*.....L. A. WOOD (chairman), P. H. ABELSON,  
 F. S. DAFT, GEORGE W. IRVING, JR., J. H. McMILLEN  
*For Teaching of Science*.....M. A. MASON (chairman), F. E. FOX, M. H. MARTIN  
*Committee on Grants-in-aid for Research*.....L. E. YOCUM (chairman), H. N. EATON,  
 K. F. HERZFELD

*Committee on Policy and Planning:*  
 To January 1953.....W. A. DAYTON (chairman), N. R. SMITH  
 To January 1954.....H. B. COLLINS, JR., W. W. RUBEY  
 To January 1955.....L. W. PARR, F. B. SILSBEE

*Committee on Encouragement of Science Talent* (A. T. MCPHERSON, chairman):  
 To January 1953.....A. H. CLARK, F. L. MOHLER  
 To January 1954.....J. M. CALDWELL, W. L. SCHMITT  
 To January 1955.....A. T. MCPHERSON, W. T. READ

*Representative on Council of A. A. A. S.*.....F. M. SETZLER  
*Committee of Auditors*.....C. L. GAZIN (chairman), LOUISE M. RUSSELL, D. R. TATE  
*Committee of Tellers*.....GEORGE P. WALTON (chairman), GEORGE H. COONS, C. L. GARNER

## CONTENTS

	Page
ASTRONOMY.—Meteors and meteorites. SYDNEY CHAPMAN.....	273
BOTANY.—A new <i>Guzmania</i> from Colombia. LYMAN B. SMITH.....	282
ENTOMOLOGY.—A review of the genus <i>Tegenaria</i> in North America (Arachnida: Agelenidae). VINCENT D. ROTH.....	283
ENTOMOLOGY.— <i>Johnsonaepsylla audyi</i> , a new genus and new species of flea from North Borneo, with notes on the subfamily Leptopsyllinae (Siphonaptera). ROBERT TRAUB.....	288
MALACOLOGY.—Generic and subgeneric names in the molluscan class Scaphopoda. WILLIAM K. EMERSON.....	296
NEMATOLOGY.—The teasel nematode, <i>Ditylenchus dipsaci</i> (Kühn, 1857), Filipjev, 1936. WILBUR D. COURTNEY.....	303
NEW MEMBERS OF THE ACADEMY.....	309
OBITUARY: James Lee Peters.....	312

506. 73  
.D2 W23

VOL. 42

OCTOBER 1952

No. 10

# JOURNAL



OF THE

# WASHINGTON ACADEMY OF SCIENCES

## BOARD OF EDITORS

WILLIAM F. FOSHAG  
U.S. NATIONAL MUSEUM

J. P. E. MORRISON  
U.S. NATIONAL MUSEUM

JOHN C. EWERS  
U.S. NATIONAL MUSEUM

## ASSOCIATE EDITORS

F. A. CHACE, JR.  
BIOLOGY

MIRIAM L. BOMHARD  
BOTANY

J. I. HOFFMAN  
CHEMISTRY

R. K. COOK  
PHYSICS AND MATHEMATICS

T. P. THAYER  
GEOLOGY

PHILIP DRUCKER  
ANTHROPOLOGY

C. W. SABROSKY  
ENTOMOLOGY

PUBLISHED MONTHLY

BY THE

WASHINGTON ACADEMY OF SCIENCES

MOUNT ROYAL & GUILFORD AVES.

BALTIMORE, MARYLAND

Entered as second class matter under the Act of August 24, 1912, at Baltimore, Md.  
Acceptance for mailing at a special rate of postage provided for in the Act of February 28, 1925.  
Authorized February 17, 1949

## Journal of the Washington Academy of Sciences

This JOURNAL, the official organ of the Washington Academy of Sciences, publishes: (1) Short original papers, written or communicated by members of the Academy; (2) proceedings and programs of meetings of the Academy and affiliated societies; (3) notes of events connected with the scientific life of Washington. The JOURNAL is issued monthly. Volumes correspond to calendar years.

*Manuscripts* may be sent to any member of the Board of Editors. It is urgently requested that contributors consult the latest numbers of the JOURNAL and conform their manuscripts to the usage found there as regards arrangement of title, subheads, synonymies, footnotes, tables, bibliography, legends for illustrations, and other matter. Manuscripts should be typewritten, double-spaced, on good paper. Footnotes should be numbered serially in pencil and submitted on a separate sheet. The editors do not assume responsibility for the ideas expressed by the author, nor can they undertake to correct other than obvious minor errors.

*Illustrations* in excess of the equivalent (in cost) of one full-page halftone are to be paid for by the author.

*Proof.*—In order to facilitate prompt publication one proof will generally be sent to authors in or near Washington. It is urged that manuscript be submitted in final form; the editors will exercise due care in seeing that copy is followed.

*Unusual cost* of foreign, mathematical, and tabular material, as well as alterations made in the proof by the author, may be charged to the author.

*Author's Reprints.*—Reprints will be furnished in accordance with the following schedule of prices (approximate):

Copies	4 pp.	8 pp.	12 pp.	16 pp.	20 pp.	Covers
100	\$3.25	\$6.50	\$ 9.75	\$13.00	\$16.25	\$3.00
200	6.50	13.00	19.50	26.00	32.50	6.00
300	9.75	19.50	29.25	39.00	48.75	9.00
400	13.00	26.00	39.00	52.00	65.00	12.00

*Subscriptions* or requests for the purchase of back numbers or volumes of the JOURNAL or the PROCEEDINGS should be sent to HARALD A. REHDER, Custodian and Subscription Manager of Publications, U. S. National Museum, Washington 25, D. C.

*Subscription Rates* for the JOURNAL.—Per year..... \$7.50

Price of back numbers and volumes:	Per Vol.	Per Number
Vol. 1 to vol. 10, incl.—not available*	—	—
Vol. 11 to vol. 15, incl. (21 numbers per vol.)	\$10.00	\$0.70
Vol. 16 to vol. 22, incl. (21 numbers per vol.)	8.00	0.60
Vol. 23 to current vol. (12 numbers per vol.)	7.50	0.90

\* Limited number of complete sets of the JOURNAL (vol. 1 to vol. 41, incl.) available for sale to libraries at \$348.50.

MONOGRAPH No. 1, "The Parasitic Cuckoos of Africa," by Herbert Friedmann. \$4.50

PROCEEDINGS, vols. 1-13 (1899-1911) complete..... \$25.00

Single volumes, unbound..... 2.00

Single numbers..... .25

*Missing Numbers* will be replaced without charge provided that claim is made to the Treasurer within 30 days after date of following issue.

*Remittances* should be made payable to "Washington Academy of Sciences" and addressed to the Treasurer, H. S. RAPPLEYE, 6712 Fourth Street, N.W., Washington 12, D.C.

*Exchanges.*—The Academy does not exchange its publications for those of other societies.



# JOURNAL OF THE WASHINGTON ACADEMY OF SCIENCES

VOLUME 42

October 1952

No. 10

BIOCHEMISTRY.—A bioassay of some stereoisomeric constituents of allethrin.  
W. A. GERSDORFF and NORMAN MITLIN, U. S. Bureau of Entomology and Plant Quarantine.

In the study of the toxicity of pyrethroids in relation to chemical structure it has been of interest to determine the effect, if any, of differences in the arrangement of the atoms in the molecule. The relative toxicity of position isomers has been touched upon only with a comparison of two esters differing in point of attachment of the acyl group to the cyclopentenolone nucleus (LaForge et al., 1948), two pairs of esters differing in position of the double bond in the butenyl side chain (LaForge et al., 1948; Gersdorff, 1949a), two monochloro derivatives of allethrin (Gersdorff and Mitlin, 1951), and three pairs of esters of different cyclopropanecarboxylic acids (LaForge et al., 1952).

Most of the available isomers have differed only in spatial configuration. In tests with the pyrethrins and cinerins no differences in relative toxicity were demonstrated between the esters formed from the same *d-trans* acid with the *d-cis* and *dl-cis* forms of the same pentenolone (Gersdorff, 1947). Appreciable differences in toxicity were found, however, when there were differences in optical activity in the acid component, whether the cyclopentenolone possessed the 2-butenyl side chain (Gersdorff, 1949a) or the allyl side chain (Gersdorff, 1949a, b; Elliott et al., 1950; Fales et al., 1951; LaForge et al., 1952). No differences in toxicity were found between the esters of the *cis* and *trans* forms of the acid component, whether the cyclopentenolone possessed the 2-butenyl or the allyl side chain (Gersdorff, 1949a). However, only small amounts of the acids were available for the preparation of the esters (Schechter et al., 1949), so that there was some question of their purity (Gersdorff and Mitlin, 1951);

therefore, small differences in their toxicity, otherwise measurable, could have been missed.

A similar interest has continued in the studies with the stereoisomeric constituents of allethrin (*dl*-2-allyl-4-hydroxy-3-methyl-2-cyclopenten-1-one—that is, *dl*-allethrolone—acylated with a mixture of *cis* and *trans dl*-chrysanthemum monocarboxylic acids). Information on their relative toxicities and contents in allethrin would be of considerable importance. Allethrin may be considered a mixture of four racemic pairs of isomers, two being esters of the *cis* form of the acid and two of the *trans* form.

In 1950 chemists in the Bureau of Entomology and Plant Quarantine prepared the *cis* and *trans* fractions in nearly pure condition and in quantities adequate for extensive tests. A study was therefore undertaken to determine under these improved conditions the relative toxicities of the two fractions and of allethrin itself and to estimate by means of these values the amounts of the two in allethrin. By cooling distilled allethrin the chemists also obtained a crystalline compound which they identified as one of the racemic *trans* pairs and designated the  $\alpha$ -*dl-trans* isomer of allethrin. A sample (A) of this compound was included in the study.

In 1951 one of the manufacturers of allethrin submitted to the Bureau a crystalline compound (sample C) obtained by holding commercial allethrin at 4° C. and found to be identical chemically with the Bureau's sample of the  $\alpha$ -*dl-trans* isomer (Schechter et al., 1951). Another series of tests was made to compare the two products insecticidally, this time a newly prepared sample (B) from the distilled allethrin being used.

The oil obtained from the filtrate from the  $\alpha$ -*dl-trans* isomer, designated the  $\beta$ -*dl-trans* isomer, was included in this series.

**Materials.**—Thus four new materials were available for comparison of toxicity—the mixture of the two *dl-cis* isomers, the mixture of the two *dl-trans* isomers, the  $\alpha$ -*dl-trans* isomer, and the  $\beta$ -*dl-trans* isomer. The term “isomer” refers in each case to a pair of optical isomers. The first two mixtures were about 95 percent pure. The sample of the  $\alpha$ -*dl-trans* isomer was pure. The  $\beta$ -*dl-trans* isomer contained about 5 percent of dissolved  $\alpha$ -*dl-trans* isomer. The  $\alpha$ -*dl-trans* isomer was represented by three separately prepared samples (A, B, and C). Two mixtures of the *dl-cis* and *dl-trans* fractions in the proportions 3:7 and 1:1 were also prepared. A distilled sample of allethrin, analyzing 95 percent by the hydrogenolysis method, and a sample of pyrethrins, 52 percent of which consisted of pyrethrin I and cinerin I (A.O.A.C. method), were used as standards of comparison.

Sprays of these materials were prepared by dissolving them in refined kerosene at concentrations selected according to preliminary tests.

**Evaluation of relative toxicity.**—The method of assay was based on the comparison of the relative toxicities of the components of a mixture with the relative toxicity of the mixture. These values were obtained from replicated tests at four concentrations made with the Campbell turntable. The test insect was the laboratory-reared adult house fly (*Musca domestica* L.). Approximately 100 flies, averaging 2 to 3 days in age, were used in each test. Knockdown and mortality are summarized in Table 1. The results are arranged in two series, each giving the means obtained with a different group of seven populations of flies. Tests with all materials in each group were made simultaneously.

Methods of probit analysis described by Finney (1947) were used to fit the regression lines to the mortality data and to estimate the LC 50 and its standard error for each of the materials. The estimations are given in Table 2. Relative toxicity is calculated as the inverse ratio of LC 50's. The equations for the lines showing the regression of mortality, expressed in probits, on concentration

in milligrams per deciliter, expressed as logarithms, are as follows:

Series 1:

<i>dl-cis</i> isomers	$Y = 2.902X - 0.7654$
<i>dl-trans</i> isomers	$Y = 2.902X - 0.2040$
Mixtures of <i>dl-cis</i> and <i>dl-trans</i> isomers:	
3:7	$Y = 2.902X - 0.3823$
1:1	$Y = 2.902X - 0.4390$
Allethrin	$Y = 2.902X - 0.5684$
$\alpha$ - <i>dl-trans</i> isomer, sample A	$Y = 3.722X - 4.0297$
Pyrethrins	$Y = 2.384X - 0.7338$

Series 2:

$\alpha$ - <i>dl-trans</i> isomer.	
Sample B	$Y = 3.241X - 2.8675$
Sample C	$Y = 3.241X - 2.8706$
$\beta$ - <i>dl-trans</i> isomer	$Y = 2.690X + 0.2439$
Allethrin	$Y = 2.499X + 0.0583$
Pyrethrins	$Y = 2.479X - 0.8047$

In series 1 the slopes of the individually fitted lines with their standard errors were, respectively,  $2.814 \pm 0.097$ ,  $2.952 \pm 0.095$ ,  $2.678 \pm 0.093$ ,  $3.054 \pm 0.099$ ,  $3.050 \pm 0.101$ ,  $3.722 \pm 0.118$ , and  $2.384 \pm 0.088$  probits per unit log concentration. The results with the *cis* and *trans* fractions and their mixtures could be fitted with parallel lines, so this was done as their equations above show, the generalized regression coefficient being  $2.902 \pm 0.043$ . The slopes of the lines for the  $\alpha$ -*trans* isomer and pyrethrins were significantly different, however, so their individual equations are given.

In series 2 the individual slopes with their standard errors were, respectively,  $3.386 \pm 0.112$ ,  $3.109 \pm 0.107$ ,  $2.690 \pm 0.093$ ,  $2.499 \pm 0.093$ , and  $2.479 \pm 0.094$ . The data for the two samples of the  $\alpha$ -*trans* compound could be fitted by parallel lines with a generalized regression coefficient of  $3.241 \pm 0.077$ . The slopes for the three other materials are significantly different from those for the  $\alpha$ -*trans* samples but not among themselves. However, the slope for allethrin is usually slightly greater than that for pyrethrins when compared by this method. Therefore, it was thought best to use the individually fitted lines for these three materials. That these lines will show more nearly true relationships may be seen if allethrin, the  $\alpha$ -*trans* isomer, and pyrethrins are compared by means of LC 50's in the two series. The difference in relative susceptibility of different populations of flies has resulted in greater variation in the measurements with

pyrethrins. Therefore, differences in relative toxicity values involving pyrethrins are due essentially to the measurements made with that insecticide.

*Assay.*—To estimate the amounts of components in a mixture by means of relative toxicity, it is necessary to determine equivalents and to assume or establish that the joint action of the components is of the similar type as defined by Bliss (1939). It does not seem likely that synergistic or antagonistic action will occur in mixtures of components so nearly alike structurally. In the three mixtures of the *cis* and *trans* fractions there can be no pronounced action of either of these types. As shown by the LC 50's in Table 2, by the equations, or indeed by the mortalities in Table 1, the toxicities of these mixtures fall between those of the individual fractions, in themselves not greatly different in toxicity. If one of the fractions is chosen as a standard of comparison and the insecticide equivalents in terms of this standard calculated for the LC 50's of the two prepared mixtures, it will be found that they do not differ greatly from the standard. This was done in Table 2 with the *cis* fraction as the standard.

To find whether there was a significant departure from similarity, the relative toxicity on the equivalent basis was determined. This is also given in Table 2, together with its logarithm, since tests of significance are properly made on the log concentration scale. When these log ratios are compared with the minimum log ratio required to demonstrate synergism or antagonism, it is seen that there is no difference from similarity in the action of these components when mixed.

If the joint action is similar one component may be substituted for the other in a constant ratio without altering the toxicity of the mixture. The percentage composition of the two fractions in the sample of allethrin used may therefore be calculated on the basis of their relative toxicities. Thus, the sum of the equivalents of the components would equal the equivalent of the mixture, stated as a general equation as follows:

$$p_c R_c + (1 - p_c) R_t = R_m$$

in which  $p_c$  is the proportion of the *cis* frac-

TABLE 1.—KNOCKDOWN AND MORTALITY OF HOUSE FLIES CAUSED BY CONSTITUENTS OF ALLETHRIN AND THEIR MIXTURES IN KEROSENE SPRAYS  
All tests replicated 7 times

Material	Concentration	Knock-down in 25 minutes	Mortality in 1 day
	Mg per ml	Percent	Percent
<b>SERIES 1:</b>			
<i>dl-cis</i> isomers	2.0	100	83.8
	1.0	100	50.0
	0.5	99.7	14.8
	.25	99.7	8.4
<i>dl-trans</i> isomers	2.0	100	93.0
	1.0	100	72.5
	0.5	100	41.0
	.25	100	11.2
Mixtures of <i>dl-cis</i> and <i>dl-trans</i> isomers:			
3:7	2.0	100	90.9
	1.0	100	61.0
	0.5	100	32.9
	.25	98.7	12.7
1:1	2.0	100	89.4
	1.0	100	69.5
	0.5	100	24.9
	.25	97.1	8.8
Allethrin	2.0	100	86.2
	1.0	100	62.7
	0.5	99.9	25.4
	.25	98.9	4.8
$\alpha$ - <i>dl-trans</i> isomer, sample A	8.0	100	97.2
	4.0	100	75.1
	2.0	99.9	26.8
	1.0	99.0	8.2
Pyrethrins	8.0	100	88.4
	4.0	100	68.3
	2.0	100	39.3
	1.0	100	17.2
<b>SERIES 2:</b>			
$\alpha$ - <i>dl-trans</i> isomer:			
Sample B	8.0	99.0	95.4
	4.0	100	74.8
	2.0	97.7	25.2
	1.0	95.0	10.9
Sample C	8.0	100	94.4
	4.0	98.9	72.9
	2.0	99.1	24.5
	1.0	90.1	13.7
$\beta$ - <i>dl-trans</i> isomer	2.0	100	90.6
	1.0	100	74.1
	0.5	99.7	48.0
	.25	98.4	12.8
Allethrin	2.0	100	80.3
	1.0	100	50.9
	0.5	99.4	22.9
	.25	91.6	8.5
Pyrethrins	8.0	100	94.9
	4.0	100	69.3
	2.0	100	45.2
	1.0	100	21.7

tion and  $R_c$ ,  $R_t$ , and  $R_m$  are the respective toxicity ratios of the *cis* and *trans* fractions and the mixture. The ratios may be relative to any standard, but if based on allethrin the values given in Table 2 may be introduced as follows:

$$p_c 0.85 + (1 - p_c) 1.33 = 1.00$$

from which  $p_c = 0.69$  and  $1 - p_c = 0.31$ . Thus, according to this bioassay the *cis* isomers comprised about 69 percent and the *trans* isomers about 31 percent of the sample of allethrin used in this study.

The use of relative toxicities in such an assay may be tested by substituting the appropriate values for the two prepared mixtures in the above equation, as follows:

$$\text{For the 3:7 mixture, } p_c 0.85 + (1 - p_c) 1.33 = 1.16, \text{ from which } p_c = 0.35.$$

$$\text{For the 1:1 mixture, } p_c 0.85 + (1 - p_c) 1.33 = 1.11, \text{ from which } p_c = 0.46.$$

The differences from the actual proportions of the *cis* fraction used in the mixtures, 0.30 and 0.50, are within experimental error.

In series 2 the assay of the  $\alpha$ -*dl-trans* and  $\beta$ -*dl-trans* isomers may proceed in the same fashion, since the two together form the total *trans* fraction. However, in this case

similar action is assumed since no prepared mixtures were tested. Since the  $\beta$ -*dl-trans* fraction tested still contained about 5 percent of the  $\alpha$ -*dl-trans* isomer, a correction for this should first be made. The substituted equation for the correction is

$$0.05 \times 0.35 + 0.95 \times R_\beta = 1.62$$

from which  $R_\beta$  (the ratio of toxicity of the pure  $\beta$ -*dl-trans* isomer) is 1.69. Now the proportion of the two isomers may be obtained from the substituted equation,  $p_\alpha$  representing the proportion of  $\alpha$  isomer

$$p_\alpha 0.35 + (1 - p_\alpha) 1.69 = 1.33$$

from which  $p_\alpha = 0.27$  and  $1 - p_\alpha = 0.73$ . Thus, 27 percent of the *dl-trans* fraction consisted of the  $\alpha$  isomer and 73 percent the  $\beta$  isomer. Since the *trans* fraction was only 31 percent of allethrin, the two isomers comprised 8 and 23 percent of allethrin, respectively.

*Discussion.*—In the present study with materials of 95 percent purity, the *trans* fraction was shown to be 1.56 as toxic as the *cis* fraction. This ratio, obtained in the comparison of the separate materials, is substantiated by the relative toxicities deter-

TABLE 2.—RELATIVE TOXICITY OF SOME CONSTITUENTS OF ALLETHRIN AND THEIR DERIVED CONTENT IN ALLETHRIN

Material	LC 50		Toxicity Relative to—		Log of Ratio of Equivalents	Content in Allethrin
	Original Basis	<i>dl-cis</i> Isomers Equivalent	Allethrin, Original Basis	<i>dl-cis</i> Isomers Equivalent Basis		
	mg per dl	mg per dl				
Series 1:						
<i>dl-cis</i> isomers	97.0 ± 2.3	97.0	0.85	1.0	—	69 ± 5
<i>dl-trans</i> isomers	62.1 ± 1.4	—	1.33	—	—	31 ± 5
Mixtures of <i>dl-cis</i> and <i>dl-trans</i> isomers:						
3:7	71.5 ± 1.7	99.5	1.16 (1.19) <sup>1</sup>	0.975	-0.011	—
1:1	74.8 ± 1.6	95.7	1.11 (1.09)	1.014	0.006	—
Allethrin	82.9 ± 1.8	—	1.0	—	—	—
$\alpha$ - <i>dl-trans</i> isomer, sample A	266.5 ± 5.1	—	0.31	—	—	7 ± 1 <sup>2</sup>
Pyrethrins	254.0 ± 6.6	—	0.33	—	—	—
Series 2:						
$\alpha$ - <i>dl-trans</i> isomer:						
Sample B	267.8 ± 5.6	—	0.35	—	—	7 ± 1 <sup>2</sup>
Sample C	268.4 ± 6.0	—	0.35	—	—	7 ± 1 <sup>2</sup>
$\beta$ - <i>dl-trans</i> isomer	58.6 ± 1.4	—	1.62 <sup>2</sup>	—	—	24 ± 1 <sup>2</sup>
Allethrin	94.9 ± 2.5	—	1.0	—	—	—
Pyrethrins	219.5 ± 5.8	—	0.43	—	—	—
Minimum required to demonstrate synergism or antagonism					±0.030	—

<sup>1</sup> Figures in parentheses calculated for similar action.

<sup>2</sup> When corrected for the presence of 5 percent of  $\alpha$ -*dl-trans* isomer in the  $\beta$ -*dl-trans* fraction, the relative toxicity of 100 percent  $\beta$ -*trans* isomer becomes 1.69 and the content figures 8 and 23 percent.

mined for the two prepared mixtures. This substantiation is very readily shown by substituting the appropriate values in the general equation above and using for them the toxicities relative to the *cis* fraction. These ratios are not given in Table 2, but are easily obtained from the LC 50 values. Thus, the ratio for the 3:7 mixture is 1.36 and for the 1:1 mixture 1.30. The equations then become as follows:

$$\text{For the 3:7 mixture, } 0.3 \times 1.00 + 0.7R_t \\ = 1.36, \text{ and } R_t = 1.51$$

$$\text{For the 1:1 mixture, } 0.5 \times 1.00 + 0.5R_t \\ = 1.30, \text{ and } R_t = 1.60$$

These two indirect estimations of the relative toxicity of the *trans* fraction agree well with the direct estimation.

In series 2 the samples of the  $\alpha$ -*dl-trans* isomer prepared at different laboratories are shown to be toxicologically identical. When these results are compared with the results obtained with an earlier preparation against different populations of flies in series 1, the agreement is still good. The significantly higher regression coefficient for this compound shows that mortality caused by it increased more rapidly with concentration than did that caused by pyrethrins. Therefore, although the two toxicants had about the same range of effective concentrations, equal mortalities were not obtained throughout the course of toxic action. However, at the 50 percent mortality level the two materials were about equally toxic. This relationship, the relatively simple chemical nature of the  $\alpha$ -*dl-trans* isomer with the accompanying assurance of high purity and uniformity, the greater ease of handling, and the probably greater stability suggest that this compound may serve as a welcome substitute for pyrethrins as a standard for fly sprays.

The mixed ester formed by the acylation of racemic allethrolone with *l-trans* chrysanthemum monocarboxylic acid has been found to have little toxicity to house flies in comparison with allethrin (4 percent, LaForge et al., 1952). Even this may be due to a slight impurity, so that for practical purposes the allethrin equivalent of the mixed ester may be considered zero. Therefore, unless there is a mutually masking, antagonistic joint action, which is unlikely,

the two optical isomers in the ester—that is, the *l-trans* acid with *d*-allethrolone and with *l*-allethrolone—must have allethrin equivalents of zero. Now the  $\alpha$ -*dl-trans* isomer is one of two optical pairs—*d-trans* acid with *d*-allethrolone plus *l-trans* acid with *l*-allethrolone, or *d-trans* acid with *l*-allethrolone plus *l-trans* acid with *d*-allethrolone—and the  $\beta$ -*dl-trans* isomer is the other pair (Schechter et al., 1951). These two pairs have been found in this study to have allethrin equivalents of 0.35 and 1.69. But one isomer in each pair, as deduced above, is nontoxic. Therefore, the remaining two isomers—*d-trans* acid with *d*-allethrolone and with *l*-allethrolone—have allethrin equivalents twice those for the mixtures, or 0.70 and 3.38. The more toxic isomer, if separated, would be the most toxic pyrethroid known, about 10 times as toxic as natural pyrethrins. If these two isomers were mixed to give the esters that would be formed by the acylation of racemic allethrolone with the *d-trans* acid, in equal proportion, this mixture would have an allethrin equivalent of 2.04, for

$$0.5 \times 0.70 + 0.5 \times 3.38 = 2.04.$$

This value has been demonstrated in actual tests with such a mixture. In four comparisons by the same method as used in the present study (Gersdorff, 1949b, and unpublished data), representing a total of 32 replications at four concentrations for each material, the estimations of the allethrin equivalent of a prepared ester of *d-trans* acid with *dl*-allethrolone were 1.98, 2.15, 2.01, and 2.04.

The ratio of toxicity of allethrin to pyrethrins in the first series, 3.06, was close to the mean of evaluations by this method, but in the second series this ratio, 2.31, was the lowest ever obtained with five or more replications at several concentrations for each insecticide.

It is shown in Table 1 that all the separated constituents of allethrin caused high knockdown of flies at the concentrations used, knockdown value in general paralleling toxic value.

*Summary.*—A bioassay of stereoisomeric constituents of allethrin was made by means of an evaluation of their relative toxicity

and that of their mixtures. The materials were applied as contact insecticides in refined kerosene on the Campbell turntable. The house fly (*Musca domestica* L.) was used as the test insect.

The *dl-trans* fraction of allethrin was 1.56 as toxic as the *dl-cis* fraction. The toxic action of the two fractions when applied in mixtures was identified as similar action.

The *trans* fraction was 1.33 and the *cis* fraction 0.85 as toxic as the sample of allethrin used. On this basis the *cis* isomers comprised about 69 percent and the *trans* isomers about 31 percent of allethrin.

A crystalline compound separated from the *trans* fraction was only 0.35 as toxic as allethrin and constituted 8 percent of that insecticide. The remainder of the *trans* fraction was 1.69 as toxic as allethrin and constituted 23 percent of that insecticide.

It is deduced that half of each portion of the *trans* fraction is relatively nontoxic and that, of the remaining two isomers, *d-trans* acid with *d*-allethrolone and *d-trans* acid with *l*-allethrolone, one is 0.70 and the other 3.38 as toxic as allethrin.

All the separated constituents possessed high knockdown value.

#### LITERATURE CITED

- BLISS, C. I. *The toxicity of poisons applied jointly.* Ann. Appl. Biol. **26**(3): 585-615. 1939.
- ELLIOTT, M., NEEDHAM, P. H., and POTTER, C. *The insecticidal activity of substances related to the pyrethrins. I. The toxicities of two synthetic pyrethrin-like esters relative to that of the natural pyrethrins and the significance of the*
- results in the bioassay of closely related compounds.* Ann. Appl. Biol. **37**(3): 490-507. 1950.
- FALES, J. H., NELSON, R. H., FULTON, R. A., and BODENSTEIN, O. F. *Insecticidal effectiveness of aerosols and sprays containing esters of synthetic cyclopentenolones with natural chrysanthemum monocarboxylic acid.* Journ. Econ. Ent. **44**(2): 250-253. 1951.
- FINNEY, D. J. *Probit analysis:* 256 pp. Cambridge, 1947.
- GERSDORFF, W. A. *Toxicity to house flies of the pyrethrins and cinerins, and derivatives, in relation to chemical structure.* Journ. Econ. Ent. **40**(6): 878-882. 1947.
- *Toxicity to house flies of synthetic compounds of the pyrethrin type in relation to chemical structure.* Journ. Econ. Ent. **42**(3): 532-536. 1949.
- *Toxicity to house flies of new synthetic pyrethroid.* Soap and Sanit. Chem. **25**(11): 129, 131, 139. 1949.
- and MITLIN, NORMAN. *Relative toxicity of allethrin analogs to house flies.* Journ. Econ. Ent. **44**(1): 70-73. 1951.
- LAForge, F. B., GERSDORFF, W. A., GREEN, NATHAN, and SCHECHTER, M. S. *Allethrin-type esters of cyclopropanecarboxylic acids and their relative toxicities to house flies.* Journ. Organ. Chem. **17**(3): 381-389. 1952.
- LAForge, F. B., GREEN, NATHAN, and GERSDORFF, W. A. *Constituents of pyrethrum flowers. XXII. Synthesis and relative toxicity of two isomers of cinerin I.* Journ. Amer. Chem. Soc. **70**: 3707-11. 1948.
- SCHUCHTER, MILTON S., GREEN, NATHAN, and LAForge, F. B. *Constituents of pyrethrum flowers. XXIII. Cinerolone and the synthesis of related cyclopentenolones.* Journ. Amer. Chem. Soc. **71**: 3165-73. 1949.
- SCHUCHTER, MILTON S., LAForge, F. B., ZIMMERLI, A., and THOMAS, J. M. *Crystalline allethrin isomer.* Journ. Amer. Chem. Soc. **73**: 3541-2. 1951.

**PALEONTOLOGY.**—*New species of Lecanocrinus.* HARRELL L. STRIMPLE, Bartlesville, Okla. (Communicated by Alfred R. Loeblich, Jr.)

Much of the material used in the present study has been made available through the generosity of Drs. G. A. Cooper and A. R. Loeblich, of the U. S. National Museum, and Richard Alexander, at present a student at the University of Oklahoma. One rare specimen from the Haragan formation was collected by Mrs. Beverley Graffham on the occasion of the first field trip by herself and her husband, Allen Graffham, to the old Hunton town site under the guidance of Richard Alexander. Numerous specimens from the Henryhouse formation have been

collected by the author and his wife, Mrs. Melba Strimple.

The three most distinctive forms of *Lecanocrinus* found in the Henryhouse formation are described as new species: *L. brevis*, *L. erectus*, and *L. invaginatus*. One form from the Brownspout (Lobelville) formation is described as *L. lindenensis*, n. sp. The Haragan form is described as *Lecanocrinus hunttonensis*, n. sp.

Abbreviations are given in the first systematic description below and are used thereafter without explanation.

Genus *Lecanocrinus* Hall  
*Lecanocrinus brevis*, n. sp.  
 Figs. 13-17

Dorsal cup broad, robust, bowl-shaped, with shallowly concave base. Lower portions of basals (BB) as well as the three infrabasals (IBB) occupy the basal concavity. BB are five large plates which reach a height of 5.7 mm above the basal plane of the cup. Radials (RR) are five broad pentagonal plates which curve sharply inward before contacting the first primibrachials (PBrBr). The general contour of each radial plate is more or less flattened, whereas most species referred to the genus have gentle to strong curvature. Two low ridges and subsequently formed grooves pass from each basal to the adjoining radials. Adsutural areas of BB and RR are slightly raised, which condition continues onto the arms. Posterior interradius (post. IR) is occupied by a rather large, obliquely placed radianal (RA) and a broad anal X. The area about and including RA is strongly protruded. Conversely, anal X is sharply depressed in upper midsection. Anal X has a broad contact with posterior basal (post. B) and has very irregular lateral sides, particularly near the summit where right and left posterior radials and arms are endeavoring to regain width, which is lost in proximal portions to the large anal plates. The right posterior is the more successful in this respect and develops next to the largest arm of the crown.

The broad arms form a completely closed dome over the body cavity. Those of the right posterior, right anterior, and left anterior are broader and longer than the anterior and left posterior. This condition is reflected in the width of the RR with the exception of the right posterior where additional width is gained by encroachment upon the right distal edge of anal X. The left anterior ray is the most dominant, and the right anterior is slightly smaller than that of the right posterior. First bifurcation takes place with the second primibrachials in all rays; however, in the holotype it is the third primibrachial (PBr) that is axillary. The lateral edges of all arms are raised to form low ridges. In all rays except the anterior there is normally a second bifurcation with the third or fourth secundibrachials.

Surface ornamentation is absent other than previously noted ridges and grooves. The proximal columnals are round and small.

*Measurements (in mm).—*

	<i>Holotype</i>
Height of crown.....	22.0
Height of dorsal cup.....	6.9
Maximum width of cup.....	23.1
Width of cup at summit (anterior to posterior).....	22.7
Maximum width of IBB circle.....	8.0
Length of r. ant. B.....	10.5*
Width of r. ant. B.....	10.5*
Length of r. ant. R.....	8.9*
Width of r. ant. R.....	13.5*
Length of RA.....	7.2
Width of RA.....	6.9
Length of anal X.....	10.9
Maximum width of anal X.....	8.1

\* Measurements taken along curvature of plates.

*Remarks.*—Among described species of the genus, only two are reported to have a strong tendency toward development of raised ridges. These are *L. angulatus* Springer (1920) and *L. bacchus* (Salter) (1873), which both have upflared IBB, readily visible in side view of the dorsal cup. *L. soyei* Oehlert (1882) has an outline of dorsal cup comparable to that of *L. brevis*. It is a smaller species of lower Devonian age having a strongly granular surface.

The broad bowl-shaped dorsal cup and the unusual ridges and grooves are sufficiently distinctive to separate *L. brevis* from other known species.

*Occurrence.*—Upper Henryhouse formation, Silurian; holotype collected by Richard Alexander, NW/4 SW/4 section 4, T. 2 N., R. 6 E., paratype SW/4 NW/4 NW/4 section 33, T. 3 N., R. 6 E., two paratypes (crowns) collected by A. R. Loeblich, Jr., and W. E. Ham near the center NE/4 SW/4 section 10, T. 2 N., R. 6 E., one paratype collected by Melba Strimple in NW/4 SW/4 section 4, T. 2 N., R. 6 E., all in Pontotoc County, south of Ada, Okla.

*Types.*—To be deposited in the U. S. National Museum.

*Lecanocrinus erectus*, n. sp.

Figs. 9, 10

This species, known from specimens having complete dorsal cups and the first few brachials of the arms, is one of the largest observed in the Henryhouse formation. Three IBB form a flattened base, mildly impressed in midsection for reception of the proximal columnals. Distal portions of IBB are upflared and are readily visible in side view of the cup. Expansion of the cup is rather rapid to above midheight, thereafter it is slowly expanded to just below distal extremity

where there is a mild constriction. Above the IBB circlet, there are five BB, five large RR, one RA and one anal X. The radials are irregular in width and have somewhat flattened profiles. In the holotype, that of the right posterior has a width of 11.7 mm; right anterior, 13.6 mm; anterior, 11.8 mm; left anterior, 15.4 mm; and left posterior, 11.2 mm. RA is small and has the form of a regular quadrangle. Anal X is large and elongated and extends only a short distance above the cup summit. Raised ridges originate in the center of each basal and pass to adjoining radials where they meet just above midheight of the plates. In the post. IR, additional ridges are found. A third ray passes from r. post. R to RA and continues onto anal X. The right ray of post. B passes to anal X and a third ray passes to RA and continues onto r. post. R. In addition to the above ridges, there is a swelling along the sutures just above midheight of the RR. The area about and including the RA is protruded. Median portion of anal X is decidedly concave. Both r. post. and l. post. RR sacrifice width to the anal plates, but near the summit of the cup they regain a large portion of their width at the expense of anal X.

First primibrachials are low, wide elements; the second PBrBr are low and axillary. In the holotype, the right and left posterior axillary PBrBr have no posterolateral sides but have normal lateral sides to the anterior. This arrangement would allow first and second SBrBr to contact the distal extremity of anal X. Articulating facets of the radials and brachials are very restricted in length. A tendency toward swelling has been noted in proximal portions of the lateral sides of brachials, indicating raised ridges comparable to those found in *L. brevis*.

*Measurements (in mm).—*

	Holotype	Paratype
Height of dorsal cup.....	16.1	16.0
Maximum width of dorsal cup.....	22.3	23.3
Height of IBB above basal plane.....	?	2.0
Height of BB above basal plane.....	9.0	10.5
Maximum width of IBB circlet.....	8.0	9.6
Length of r. ant. B.....	9.5*	10.3*
Width of r. ant. B.....	10.0*	10.3*
Length of r. ant. R.....	9.6*	10.0*
Width of r. ant. R.....	13.6*	14.0*
Length of RA.....	6.0	6.4
Width of RA.....	6.0	5.1
Length of anal X.....	11.2	9.8
Maximum width of anal X.....	8.8	6.7

\* Measurements taken along curvature of plates.

*Remarks.*—This species appears to be more closely related to *L. brevis* than other described

species; however, the general outline of the cup is somewhat comparable to that of *L. soyei* (Oehlert) (1882). The later is a lower Devonian species of small size and has a decidedly granular surface. In *L. brevis* the ridge like structures are doubled and adjacent grooves are present. The tendency toward swelling along sutures is more widespread in *L. brevis* but is nevertheless found in the upper portion of the cup in *L. erectus*. The two species are quite different in shape of cups.

*Occurrence.*—Upper Henryhouse formation, Silurian; holotype and one paratype collected by Richard Alexander in SW/4 NW/4 NW/4 section 33, T. 3 N., R. 6 E., measured paratype by A. R. Loeblich, Jr., in exposure along east side of road in bluff NW/4 SW/4 section 4, T. 2 N., R. 6 E., Pontotoc County, south of Ada, Okla.

*Types.*—To be deposited in the U. S. National Museum.

***Lecanocrinus lindenensis*, n. sp.**

Figs. 5-8

The large dorsal cup is turbinate-shaped with upflared IBB visible in side view of cup. The surface is mildly granular and sutures are slightly impressed. Five BB are of equal width and height. Five RR are only slightly wider than high. RA is a small quadrangular plate, obliquely placed at the lower right hand corner of the long anal X. Anal X has an even width within the cup and extends a short distance into the interbrachial area where it terminates in a point. There is a slight depression just below the termination, smaller but similar to that found in *L. brevis* and *L. erectus*. First primibrachials are nonaxillary and are very low elements.

*Measurements (in mm).—*

	Holotype
Height of dorsal cup.....	8.9
Maximum width of cup.....	13.2
Height of IBB above basal plane.....	0.9
Maximum width of IBB circlet.....	4.6
Height of BB above basal plane.....	4.6
Length of r. ant. B.....	5.7*
Width of r. ant. B.....	5.7*
Length of r. ant. R.....	6.4*
Width of r. ant. R.....	8.2*
Length of RA.....	3.1
Width of RA.....	3.4
Length of anal X.....	6.2
Maximum width of anal X.....	4.4

\* Measurements taken along curvature of plates.

*Remarks.*—The elongated cup with mildly granular surface, slight constriction at summit, and upflared IBB of *L. lindenensis* provides differentiation from other described species. Elongated



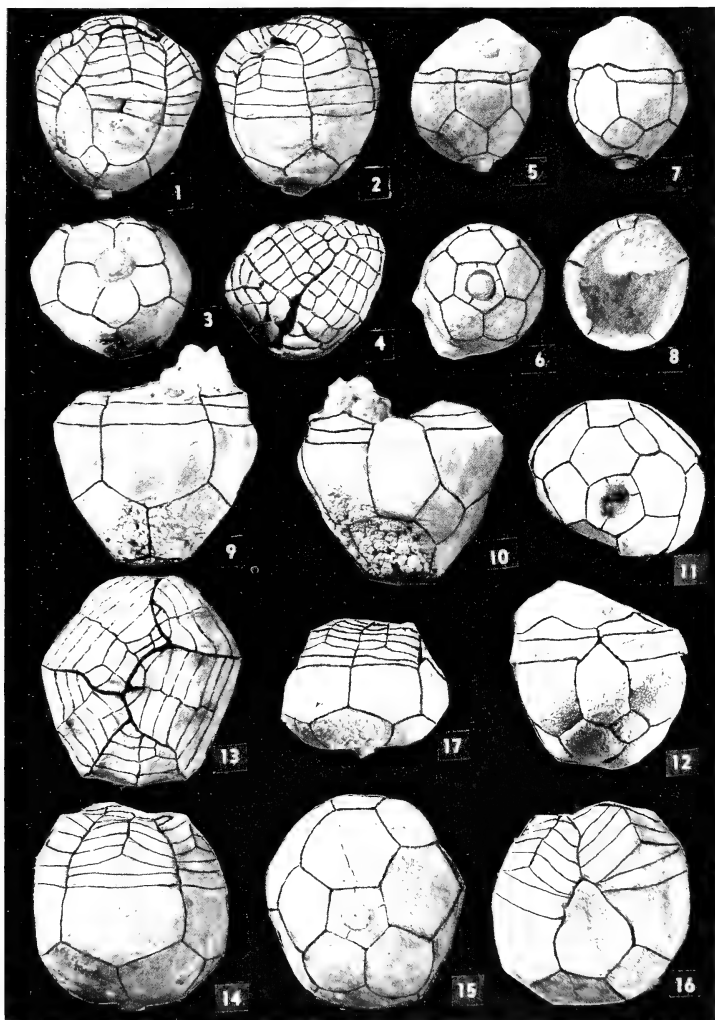

FIGS. 1-4.—*Lecanocrinus invaginat*us, n. sp.: Holotype viewed from right posterior, anterior, base, and summit (posterior at top),  $\times 1.6$ . FIGS. 5-8.—*Lecanocrinus lindencensis*, n. sp.: 5-7, Holotype viewed from anterior, base (posterior at top), and right posterior,  $\times 1.6$ ; 8, paratype viewed from summit (posterior at top),  $\times 1.6$ . FIGS. 9, 10.—*Lecanocrinus erectus*, n. sp.: Holotype viewed from anterior and posterior,  $\times 1.6$ . FIGS. 11, 12.—*Lecanocrinus hunttonensis*, n. sp.: Holotype viewed from base and posterior,  $\times 2$ . FIGS. 13-17.—*Lecanocrinus brevis*, n. sp.: 13-16, Holotype viewed from summit (posterior at top), anterior, base, and posterior,  $\times 1.6$ ; 17, paratype viewed from left posterior,  $\times 1.4$ .

RR and somewhat prominent BB suggest affinity with *L. fascietatus* (Angelin) (1878), and *L. huntonensis*, n. sp. The former species apparently has no tendency toward constriction at the summit of the cup and the anal plate is almost entirely within the dorsal cup. The later species has more pronounced surface ornamentation, more acute termination of anal plate, more deeply impressed sutures, and IBB not visible in side view of cup.

*L. erectus* is a larger species with somewhat comparable cup outline if angulation is disregarded. It is different in that radial plates are proportionately wider, there is no surface granulation, impressed sutures are absent and the RR are more irregular in width in *L. erectus*.

*Occurrence*.—Brownsport (Lobelville) formation, Silurian; holotype and three paratypes collected by A. R. Loeblich in road cuts on north side of Short Creek, North-central Rectangle, Linden Quadrangle, TVA 32 SE, east of Linden, Tenn.

*Types*.—To be deposited in U. S. Nat. Museum.

***Lecanocrinus invaginatus*, n. sp.**

Figs. 1-4

Dorsal cup truncate bowl-shaped with concave base. IBB are restricted to the basal invagination. BB are five normal plates having width equal to length except where affected by the additional plates of the posterior interradius. RR are pentagonal and only slightly wider than long. RA is very small, quadrangular and is obliquely placed at the lower right corner of anal X. Anal X is unusually long and narrow. There is no tendency toward strong tumidity, raised ridges or impressed sutures in the dorsal cup.

The arms are broad and occupy an area almost equal to that of the dorsal cup. In the holotype, first bifurcation takes place with the second PBrBr in all rays except the left posterior, wherein the first PBr is axillary. In the larger rays of the right posterior, right anterior and left anterior there is another bifurcation with the second secundibrachials in all rays. Yet another branching occurs in the inner rays only of the left anterior rami on the third tertibrachials (TBrBr). In the arms of the right posterior only, the right rami are long enough to accommodate more than three brachials above the second dichotomy and the third TBr of the inner ray is axillary. The rami of the right anterior, anterior and left posterior terminate with the third TBrBr.

*Measurements (in mm).*—

	<i>Holotype</i>
Height of crown.....	18.2
Height of dorsal cup.....	19.1
Maximum width of dorsal cup.....	16.4
Maximum width of cup at summit.....	16.4
Length of r. ant. R.....	6.3*
Width of r. ant. R.....	9.0*
Length of r. ant. B.....	6.6*
Width of r. ant. B.....	6.5*
Length of RA.....	2.6
Width of RA.....	2.6
Length of anal X.....	7.0
Maximum width of anal X.....	5.2
Height of BB above basal plane.....	6.9

\* Measurements taken along curvature of plates.

*Remarks*.—*L. invaginatus* appears to be comparable to *L. pusillus* (Hall) (1863) and *L. pisiiformis* (Roemer) (1860). The concave nature of the basal area most readily distinguishes it from those species as well as the narrow, elongated nature of the anal X. *L. meniscus* Springer (1920), has a broad base with IBB covered by the proximal columnals, but the sutures of that species are sharply impressed and the mode of arm branching is different above the first dichotomy.

*Occurrence*.—Upper Henryhouse formation, Silurian; Holotype and one paratype collected by the author in the NE/4 SW/4 section 10, T. 2 N., R. 6 E., Pontotoc County, south of Ada, Okla.

*Types*.—To be deposited in the U. S. National Museum.

***Lecanocrinus huntonensis*, n. sp.**

Figs. 11-12

Dorsal cup truncate bowl shaped. Three unequal IBB form a small subhorizontal basal platform, the median portion of which is sharply depressed. The smaller IB is right posterior in position. Five BB are rather small, hexagonal except in the posterior interradius where additional facets are necessary for reception of the two anal plates. Five RR are large, long, pentagonal plates. RA is a small quadrangular element in oblique position to the lower right of anal X which plate is long with even width and an acute distal termination. Sutures of cup plates are impressed.

Fragmentary portions of the arms consist of low nonaxillary PBrBr in all rays except the anterior which is missing from the IBB circlet upward. In the right and left posterior there are low axillary second PBrBr and a few secundibrachials.

The entire surface of this specimen is covered by medium pustules which tend to become confluent and form minute ridges.

*Measurements (in mm).—*

	<i>Holotype</i>
Height of dorsal cup.....	7.1
Maximum width of cup.....	11.7
Maximum width of cup at summit.....	11.3
Maximum diameter of IBB circlet.....	3.7
Length of r. ant. B.....	5.0*
Width of r. ant. B.....	5.0*
Length of r. ant. R.....	5.5*
Width of r. ant. R.....	6.7*
Length of RA.....	2.2
Width of RA.....	1.8
Length of anal X.....	4.7
Maximum width of anal X.....	3.2
Height of BB above basal plane.....	3.7

\* Measurements taken along curvature of plates.

*Remarks.*—*L. fasciatus* (Angelin) has an appearance more comparable to *L. huntonensis* than other described species. It differs in lacking constriction at the summit of the dorsal cup and in restriction of anal X to the cup. Anal X in

*L. huntonensis* extends well into the interbrachial area, although it does not pass above the first PBrBr. *L. invaginatus* has a somewhat comparable appearance, particularly in the elongate nature of the RR plates, but other characters are quite different.

The surface ornamentation of the present species is distinctive from that of other described species.

*Occurrence.*—Lower portion of the Haragan formation (about 15 feet above the *Camarocrinus* zone), Devonian; collected by Mrs. Beverly Grahham near Hunton townsite, west of Clarita, Okla.

*Type.*—Deposited in the U. S. National Museum.

#### REFERENCES

All cited references are to be found in BASSLER, R. S., and MOODEY, MARGARET W. *Bibliographic and faunal index of Paleozoic Pelmatozoan Echinoderms*, Geol. Soc. Amer. Special Publ. 45. 1943.

**BOTANY.**—*A new species of Sphaceloma on magnolia.* ANNA E. JENKINS, U. S. Bureau of Plant Industry, Soils, and Agricultural Engineering, and JULIAN H. MILLER, University of Georgia.

A technical description of the new species of *Sphaceloma* on *Magnolia grandiflora* L.<sup>1</sup> is here provided as follows:

*Sphaceloma magnoliae* n. sp. Fig. 1

Spots on upper leaf surface, not visible below, few to almost innumerable, scattered or localized, often concentrated along midrib and on marginal and apical areas, circular to irregular, often up to 1.5 mm in diameter, gray ("pale mouse gray"),<sup>2</sup> with a brown ("sorghum brown") margin, slightly raised, coalescent, sometimes discoloring much of the upper leaf surface except basal area; leaf tissue in marginal and apical region sometimes killed, then noticeably brown ("snuff brown") below; acervuli, numerous, epiphyllous, arising intraepidermally, erumpent, black, generally with a hyaline prosenchymatic base, 20–40 $\mu$  in diameter, 12–24 $\mu$  thick; palisade of conidiophores 12–16 $\mu$  thick; conidiophores characteristically awl-shaped, continuous or 1-septate; conidia not seen on the acervuli.

<sup>1</sup> JENKINS, A. E. *Sphaceloma causing scab of Magnolia grandiflora*. *Abst. Phytopathology* 33: 6. 1943.

<sup>2</sup> RIDGWAY, R. *Color standards and color nomenclature*. 45 pp., 42 pls. Washington, 1912.

*Elsinoë* stage in process of development.

Maculae epiphyllae, sparsae ad numerosimae conspersae, saepe aggregatae vel confluentes, subelevatae, circulares vel subcirculares, usque 1.5 mm in diam., griseae, margine brunneo circumdatae, ex acervulis atro punctatae; acervuli intraepidermales, dein erumpentes, compacti, usque 40 $\mu$  in diam. et 12–24 $\mu$  crassi; conidio phora obscura, continua vel 1 septate, usque 16 $\mu$ , stromate pallido oriunda; conidia non visa.

*Distribution.*—Producing the disease termed "magnolia scab" on leaves of *Magnolia grandiflora* (Magnoliaceae) in Florida, Georgia, Louisiana, and Mississippi. The disease was abundant in Georgia in 1941–1943, in some cases causing severe leaf fall. More recently its attack appears to have been less harmful.

*Specimens examined.*—As follows<sup>3</sup>:

#### FLORIDA:

Vic. Century, Aug. 5, 1943, W. B. Tisdale.

<sup>3</sup> USM = Mycological Collections of the Bureau of Plant Industry, Soils, and Agricultural Engineering, Plant Industry Station, Beltsville, Md. IB = Herbarium, Seção de Fitopatologia, Instituto Biológico, São Paulo, Brazil.

MSE = Jenkins - Bitancourt, Myriangiales selecti exsiccati.

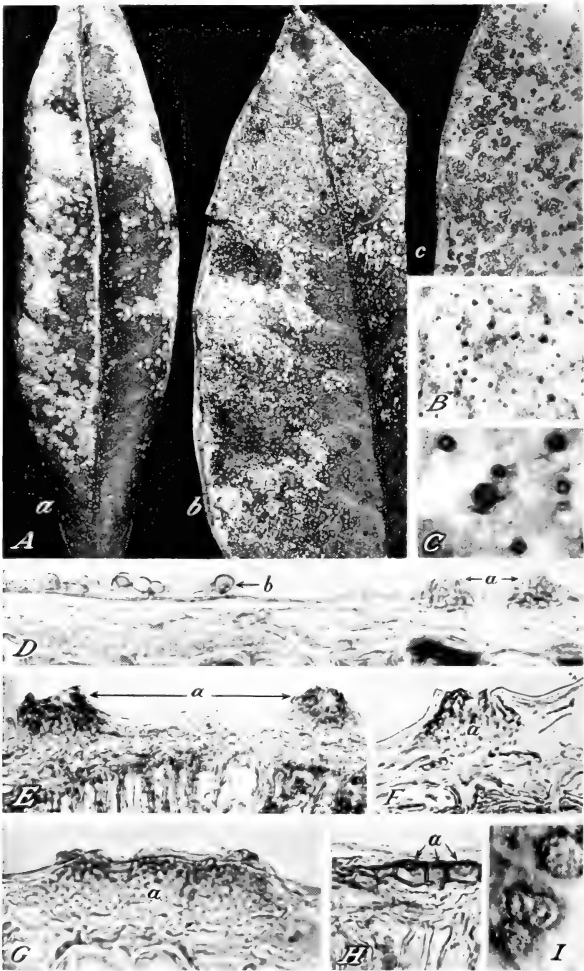

FIG. 1.—*Sphaecloma magnoliac* on leaves of *Magnolia grandiflora* (type specimen): A, a-c,  $\times 1$ . B, C, Dark acervuli, B,  $\times 19$ ; C,  $\times 100$ . D-G, Sections showing acervuli (a) and superficial hyphae (b). H, a, Hypha,  $\times 500$ . I, Lesions from A, c,  $\times 5$ .

## GEORGIA:

Athens, June 1943 (edge of a swamp) and Aug. 26, 1948, J. H. Miller.

Augusta, Fruitland Nurseries, December 1941, J. H. Faulk, Comm. Alma W. Waterman: February 1942 and March 23, 1942 (TYPE, USM 74223, IB 4673, MSE 427), J. H. Miller. Goshen Plantation, Apr. 7,

1943, Mrs. J. Mck. Speer (MSE 428).

Savannah, April 1944, M. E. Fowler.

LOUISIANA: Hammond, Apr. 1 and Oct. 15, 1943 (MSE 429), A. G. Plakidas. Culture isolated by Plakidas, Nov. 8, 1950, deposited in American Type Culture Collection, no. 11187.

MISSISSIPPI: Poplarville, July 16 and Sept. 3, 1942; Apr. 21 and May 19, 1943, J. A. Pinckard.

ENTOMOLOGY.—*A new larvaevorid fly parasitic on tortoise beetles in South America (Diptera)*. CURTIS W. SABROSKY, *Bureau of Entomology and Plant Quarantine*.

In the course of studies by H. L. Parker and associates in the South American Parasite Laboratory of the U. S. Bureau of Entomology and Plant Quarantine, a larvaevorid fly of the genus *Eucelatoriopsis* Townsend was reared from tortoise beetles (Chrysomelidae: Cassidinae). It was recognized as new by several workers, but no description has been published. With additional material of the genus before me, and with material kindly made available by Raúl Cortés, I have reexamined the problem and offer the following description of the new species.

The genus *Eucelatoriopsis* Townsend (1927) was monobasic for *E. teffeensis* Townsend. Another species, *Dexodes meridionalis* Townsend (1912), was referred there by Townsend (*Manual of myiology*, pt. 10: 51, 1940), but it differs from the genotype and also from the new species described below in having a strong pair of median marginal bristles on the first abdominal segment of the female, minute hairlike ocellar bristles, and quite conspicuously (though short) haired eyes. It may not belong in *Eucelatoriopsis sensu stricto*.

The material before me also contains several undescribed species that do belong to *Eucelatoriopsis* in its restricted sense. Some of these may be important parasites, for all specimens of known origin were reared from various species of cassidine beetles. It is hoped that workers who have access to infestations of these beetles will rear adequate series of the parasites so that the other forms may be properly studied. At present there are available only one to four specimens per species, and usually only one sex, and it is undesirable in a group of such closely related forms to describe from such inadequate material.

***Eucelatoriopsis parkeri*, n. sp.**

Distinguished from its congeners by the head bright yellow pollinose, body with bluish-gray appearance, and thorax almost bivittate as seen with the naked eye.

*Male*.—Head black, the parafrontals, parafacials, cheeks, and postorbites uniformly bright yellow pollinose, the clypeus silvery and the facials somewhat intermediate; occiput black above but silvery gray pollinose below; occipital hairs white except for a few near the vertex; hairs of cheeks and parafrontals black, those of the latter short and inconspicuous; antennae and palpi black. Thorax black with bluish-gray pollen, in strong contrast to *E. teffeensis* which has bright yellowish-gray pollen; mesonotum with four moderately broad black stripes, the outer twice the width of the inner, the inner stripes much more widely separated than either is from the adjacent outer stripe, so that to the naked eye the mesonotum appears to have only two stripes (an appearance accentuated by any discoloration). Abdomen black in ground color, last three segments broadly gray pollinose on anterior two-thirds, subshining brown-black posteriorly, with narrow median black stripe, especially when viewed at certain angles. Legs black, claws brown, pulvilli yellowish. Wings clear to faintly tinted with brown.

Frontal bristles descending to point opposite the apex of second antennal segment, usually three on each side below base of antennae; typically three pairs of reclinate upper frontals; ocellars approximately equal in length to intermediate frontal bristles; facial bristles ascending only three or four, and decreasing sharply in length, above the vibrissae; width of front at vertex approximately one-fourth the width of the head. Prosternum with fine hairs laterally. Lower sternopleural bristle much shorter than the others, rarely absent or hairlike. Scutellum

broadly rounded distally, the subapical marginal scutellar bristles widely spaced, long and strong, extending beyond the hind margin of the second abdominal segment; apical scutellars cruciate, not quite as long as the discal scutellars, each of the latter inserted almost directly anterior to the base of a subapical scutellar. Abdomen typically with one pair, occasionally two, of median discal bristles on second to fourth segments. Third vein with two to four setae at base; claws and pulvilli long.

*Female*.—As described for the male, but with two pairs of reclinate upper frontal bristles and two pairs of proclinate frontals; width of front at vertex approximately three-tenths the width of the head, the front widening anteriorly; piercing sternotheca short, approximately equal to length of fourth abdominal segment; spines on ventral carina on second and third segments notably stronger toward the hind margin of the segment; claws and pulvilli very short.

*Length*.—5–6.5 mm.

*Types*.—Holotype male (no. 61492 in U. S. National Museum) and allotype, Montevideo, Uruguay, emerged December 21, parasite of *Chelymiorpha variabilis* var. *crucifera* Boheman (determined by Juan Bosq and H. S. Barber) feeding on *Convolvulus arvensis* L. (H. L. Parker no. 213). Paratypes: 84(37♂♂, 47♀♀), same locality and collector, with other data as follows: 11(4♂♂, 7♀♀), same data as holotype; 19(10, ♂♂ 9♀♀), February 1942, same host and host plant as holotype (Parker no. 703.1); 54(23♂♂, 31♀♀), parasitic on *Anacassis proliza* (Boheman) feeding on *Baccharis spicata* Peri, December 1941 and February 1942 (Parker nos. 634, 638). Paratypes have been deposited in the collections of the U. S. National Museum, American Museum of Natural History, British Museum (Nat. Hist.), H. J. Reinhard, Raúl Cortés, and Paul H. Arnaud, Jr.

*Remarks*.—The conspicuously and evenly yellow-pollinose head and bluish-gray body will distinguish the species easily from the genotype, *E. teffeensis*, and either or both of these features from most of the undescribed species now before me. In most of the others, furthermore, the mesonotum appears quadrivittate to the naked eye.

An analysis of the variation in the long and homogeneous series (topotypic and host-typic) showed that absence of a pair of median marginal bristles on the first abdominal segment in the

female, presence of a pair of apical scutellar bristles, three pairs of postsutural dorsocentrals, three sternopleurals, one posterior bristle on the fore tibia, and one anterior bristle on the mid-tibia are unusually stable characters. Most specimens have the infrasquamals present, but occasional specimens lack any trace of them. The median discal bristles on the intermediate segments are definitely variable in number, especially in the females, with occasional specimens having them entirely absent, and others having them present in various combinations on different segments and sometimes between right and left sides.

The proper generic position of the new species will require much further study on a broad basis because of the many restricted genera proposed by Townsend in the Neotropical fauna. However, the presence in the female of a piercing sternotheca and spined ventral carina on the abdomen associates it readily, and probably also fundamentally, with a group of compsilurine genera such as *Compsilura* and *Eucelatoria* and with a few genera placed by Townsend in other tribes. Of this group, *Eucelatoriopsis* and *Eucelatoria* differ from the others particularly in lacking a pair of median marginal bristles on the first abdominal segment of the female. The former differs from *Eucelatoria* in having a pair of apical scutellar bristles and in lacking strong bristles on the facialia. If these last three characters prove not to be generic in value, considerable synonymy may result, but they serve for present purposes to indicate the association of the new species.

The new species agrees with the generic characters listed for *Eucelatoriopsis* by Townsend (*Manual of myiology*, pt. 10: 50, 1940) except as follows: Eyes with minute, sparse hairs; ocellar bristles moderately short in female, but decidedly longer in male (the opposite of Townsend's statement); three pairs of postacrostichal bristles (the holotype of *E. teffeensis* has only two pairs, but this may be variation, as several specimens of *E. parkeri* show the same thing); anal segment of female not as high and as large as in *teffeensis*; female abdomen generally with a pair of median discal bristles on third and fourth segments and often on the second, but sometimes with none, suggesting that the holotype of *teffeensis*, which lacks discal bristles, may also be atypical of its species. In Townsend's key to the tribe Compsilurini (*Manual of myiology*, pt.

4: 90, 1936), the use in the second couplet of the unreliable (in this species at least) character of median discal bristles will cause all males and

most females of *parkeri* to pass to couplet 3, but *parkeri* is quite unrelated to either of the genera there.

ENTOMOLOGY.—*An arrangement of the Prepodesmidae, a family of African millipeds.* RALPH V. CHAMBERLIN, University of Utah. (Communicated by C. W. Sabrosky.)

The group of millipeds for which Dr. O. F. Cook in 1895 proposed the family name Prepodesmidae is likely to prove to be one of considerable size. Owing to additions made by more recent workers, a revision of the family seems desirable, and such has been projected by the present writer. However, pending the accumulation of more adequate material for this purpose, it is hoped that the present checklist, embracing the arrangement and conception of genera provisionally adopted, may prove useful. My thanks are due to Dr. E. A. Chapin, of the U. S. National Museum, for the privilege of studying the prepodesmids of the important O. F. Cook collection, thus making it possible for the first time to indicate with confidence the relationships of the genera proposed by that pioneer student of West African Diplopoda.

#### Family PREPODESMIDAE Cook

Prepodesmidae Cook, Amer. Nat. **30**: 416, 1896.  
Cordylporinae (as a subfamily of Oxydesmidae)  
Brolemann, Ann. Soc. Ent. France **84**: 562, 1916.

#### PREPODESMINAE, n. subfam.

Proposed for the group of genera in which the male gonopods have a conspicuous accessory process arising from the femoral division proximal of the origin of the solenomerite.

#### Genus *Ancylochetus* Attems

*Ancylochetus* Attems, Zoologica **30** (3/4) (Heft 79): 96, 1931.

Generotype: *Ancylochetus signatus* Attems.

#### *Ancylochetus signatus* Attems

*Ancylochetus signatus* Attems, Zoologica **30** (3/4) (Heft 79): 96, figs. 138-140, 1931.

(LIBERIA.)

#### *Basacantha*, n. gen.

Characterized primarily by having a branch or spine from the base of the solenomerite. (Fig. 1.)

Generotype: *Anisodesmus lundae* Chamberlin.

#### *Basacantha decora* (Attems)

*Cordylporus decorus* Attems, Rev. Zool. Bot. Afr. **17**: 334, fig. 41, 1929.

(BELGIAN CONGO.)

#### *Basacantha lundae* (Chamberlin)

*Anisodesmus lundae* Chamberlin, Publ. Cult. Companhia Diamantes Angola **10**: 82, figs. 45-46, 1951.

(ANGOLA.)

#### *Basacantha mechowi* (Karsch)

*Rachidomorpha Mechowi* Karsch, Berliner Ent. Zeitschr. **25**: 287, 1881.

*Cordylporus mechowi* Attems, Denkschr. Akad. Wien **67**: 365, pl. 5, figs. 108-110, 1898.

*Paltothorus mechowi* Attems, Rev. Zool. Bot. Afr. **17**: 338, fig. 46, 1929.

(BELGIAN CONGO.)

#### Genus *Diaphorodesmus* Silvestri

*Diaphorodesmus* Silvestri, Ann. Mus. Genova **36**: 199, 1896.

Generotype: *Paradesmus dorsicornis* Porat.

#### *Diaphorodesmus dorsicornis* (Porat)

*Paradesmus dorsicornis* Porat, Bihang. Svenska Akad. **20** (5): 33, fig. 3, 1894.

*Diaphorodesmus dorsicornis* Silvestri, Ann. Mus. Genova **36**: 197, 1896.

(CAMEROUN, SPANISH GUINEA.)

#### *Kisantus*, n. gen.

Related most closely to *Pimodesmus*. Distinguished in having the mesal branch of the gonopods long, straight, and with a spine at base; the ectal lobe of the tibiotarsus a broad lamina widening distad and at the end curving into a hood or canopy beset with spinous points. (Fig. 2.)

Generotype: *Paltothorus tridens* Attems.

#### *Kisantus tridens* (Attems)

*Paltothorus tridens* Attems, Rev. Zool. Bot. Afr. **30**: 62, figs. 41-43, 1937.

(BELGIAN CONGO.)

#### *Congesmus*, n. gen.

Related to *Basacantha* but lacking a spine at base of the solenomerite. The lateral femoral

process in the form of a short, typically subtriangular leaf.

Genotype: *Paltophorus probus* Attems.

**Congesmus brevilobus** (Attems)

*Paltophorus brevilobus* Attems, Rev. Zool. Bot. Afr. **30**: 59, figs. 37-38. 1937.

(BELGIAN CONGO.)

**Congesmus probus** (Attems)

*Paltophorus probus* Attems, Rev. Zool. Bot. Afr. **31**: 239, figs. 16-17. 1938.

(BELGIAN CONGO.)

Genus **Kyphopyge** Attems

*Kyphopyge* Attems, Zoologica **30** (3/4) (Heft 79): 93. 1931.

Genotype: *Kyphopyge granulosa* Attems.

**Kyphopyge granulosa** Attems

*Kyphopyge granulosa* Attems, Zoologica **30**, (3/4) (Heft 79): 94, figs. 133-137. 1931.

(CAMEROUN.)

Genus **Mesodesmus** Carl

*Mesodesmus* Carl, Rev. Suisse Zool. **17**: 302. 1909.

Genotype: *Scaptodesmus roccati* Silvestri.

**Mesodesmus roccati** (Silvestri)

*Scaptodesmus roccati* Silvestri, Boll. Mus. Torino **22**, (560): 4. 1907.

*Mesodesmus rugifer* Carl, Rev. Suisse Zool. **17**: 303, fig. 1. 1909.

(WEST UGANDA.)

**Mesodesmus roccati rugifer** (Silvestri)

*Scaptodesmus rugifer* Silvestri, Bull. Mus. Torino **22**, (560): 6. 1907.

*Mesodesmus rugifer* Carl, Rev. Suisse Zool. **17**: 304, figs. 6, 1. 1909.

(UGANDA.)

Genus **Pimodesmus** Chamberlin

*Pimodesmus* Chamberlin, Bull. Amer. Mus. Nat. Hist. **57**: 243. 1927.

*Paltophorus* Attems, Rev. Zool. Bot. Afr. **30**: 41, 54. 1937.

Genotype: *Pimodesmus aglaus* Chamberlin.

**Pimodesmus aglaus** Chamberlin

*Pimodesmus aglaus* Chamberlin, Bull. Amer. Mus. Nat. Hist. **57**: 243, figs. 173-181. 1927.

*Paltophorus lisananus* Attems, Rev. Zool. Bot. Afr. **30**: 56, figs. 34, 35. 1937.

(BELGIAN CONGO.)

**Pimodesmus arenaceus** (Attems)

*Paltophorus arenaceus* Attems, Rev. Zool. Bot. Afr. **30**: 60, figs. 39-40. 1937.

(BELGIAN CONGO.)

**Pimodesmus asperus** (Carl)

*Cordyloporus* (*Neocordyloporus*) *asperus* Carl, Mem. Soc. Españ. Hist. Natur. **1**: 269, pl. 6, fig. 4. 1905.

(WEST AFRICA, CAPE SAN JUAN.)

**Pimodesmus dentatus** (Silvestri)

*Scaptodesmus rugifer* var. *dentatus* Silvestri, II Ruwenzori **1**: 332, fig. 27. 1909.

*Mesodesmus rugifer* var. *dentatus* Carl, Rev. Suisse Zool. **17**: 305. 1909.

*Paltophorus dentatus* Attems, Rev. Zool. Bot. Afr. **30**: 55. 1937.

(CENTRAL AFRICA, BIHUNGA.)

**Pimodesmus denticulatus** (Attems)

*Scolopopleura denticulata* Attems, Zoologica **30**, (3/4) (Heft 79): 99, figs. 143-146. 1931.

*Paltophorus denticulatus* Attems, Rev. Zool. Bot. Afr. **30**: 55. 1937.

(LIBERIA, LOFA RIVER.)

**Pimodesmus falcatus** (Attems)

*Cordyloporus falcatus* Attems, Rev. Zool. Bot. Afr. **17**: 334, figs. 42-45. 1929.

*Paltophorus falcatus* Attems, Rev. Zool. Bot. Afr. **30**: 56. 1937.

(BELGIAN CONGO.)

**Pimodesmus gladiator** (Attems)

*Cordyloporus gladiator* Attems, Rev. Zool. Bot. Afr. **17**: 340, fig. 47. 1929.

*Paltophorus gladiator* Attems, Rev. Zool. Bot. Afr. **30**: 56. 1937.

(BELGIAN CONGO.)

**Pimodesmus imperfectus** (Attems)

*Paltophorus imperfectus* Attems, Rev. Zool. Bot. Afr. **31**: 59, figs. 37-38. 1937.

(BELGIAN CONGO.)

**Pimodesmus longipes** (Carl)

*Cordyloporus longipes* Carl, Rev. Suisse Zool. **21**: 222, figs. 14-18. 1913.

*Paltophorus longipes* Attems, Rev. Zool. Bot. Afr. **30**: 56. 1937.

(CAMEROUN.)

**Pimodesmus nigerianus** (Attems)

*Scolopopleura nigeriana* Attems, Zoologica **30**, (3/4) (Heft 79): 98, figs. 141-142. 1931.

*Paltophorus nigerianus* Attems, Rev. Zool. Bot. Afr. **30**: 55. 1937.

(SOUTH NIGERIA.)

Genus **Prepodesmus** Cook

*Prepodesmus* Cook, Amer. Nat. **30**: 416. 1896.

*Cordyloporus* Attems, Denkschr. Akad. Wiss. Wien **67**: 363. 1896.

*Cordyloporus* subgen. *Neocordyloporus* Carl, Mem. Soc. Españ. Hist. Natur., **1**: 269. 1905.

*Cordyloporus* + *Pleuroarium* (pro part. max.) Attems, Rev. Zool. Bot. Afr. **17**: 328, 332. 1929

Genotype: *Prepodesmus tigrinus* Cook.



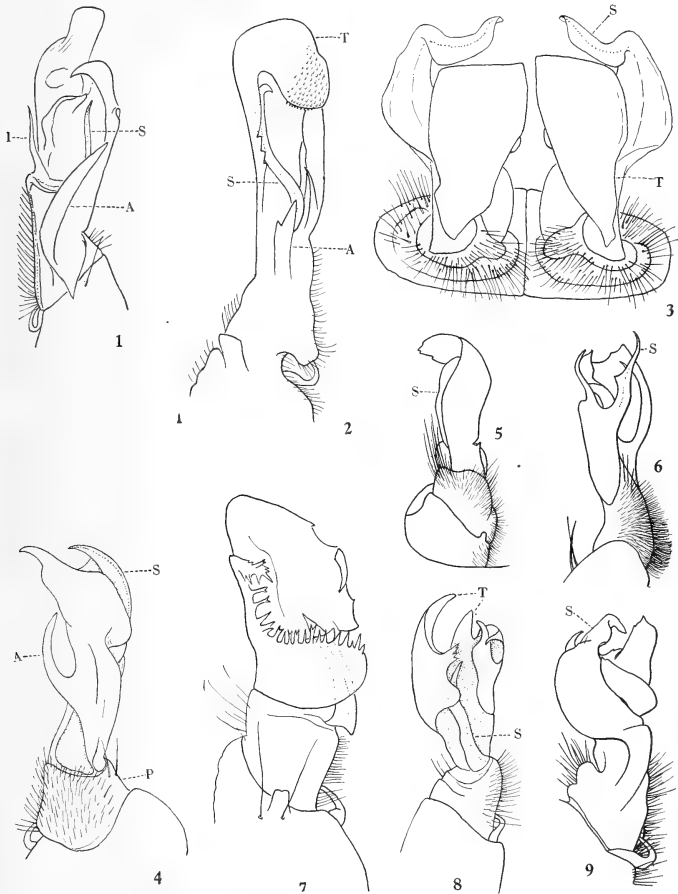

FIG. 1.—*Basacantha lundae* (Chamberlin): Gonopod, preaxial view. FIG. 2.—*Kisantus tridens* (Attems): Gonopod. FIG. 3.—*Tylodesmus crassipes* Cook: Gonopods, postaxial aspect. FIG. 4.—*Prepodesmus tigrinus* Cook: Gonopod, subcaudal aspect. FIG. 5.—*Cheirodesmus ater* Cook: Gonopod, postaxial aspect. FIG. 6.—*Isodesmus immarginatus* Cook: Gonopod, subeternal aspect. FIG. 7.—*Morphotelus lacinosus* (Attems): Gonopod, preaxial view. FIG. 8.—*Morphotelus mareesi* (Carl): Gonopod, preaxial view. FIG. 9.—*Tylodesmus albus* Chamberlin: Gonopod, anterior aspect. (A, Femoral or accessory branch; I, basal spine of solenomerite; P, prefemur; S, solenomerite.)

**Prepodesmus aubryi** (Lucas)

*Paradesmus aubryi* Lucas, Archiv Ent. **2**: 440. 1858.

*Cordyloporus aubryi* Attems, Das Tierreich, Lief. **69**: 379. 1938. (GUINEA.)

**Prepodesmus dubius** (Attems)

*Cordyloporus dubius* Attems, Rev. Zool. Bot. Afr. **30**: 45, figs. 24-25. 1937. (BELGIAN CONGO.)

**Prepodesmus mimus** Cook

*Prepodesmus mimus* Cook, Proc. Acad. Nat. Sci. Philadelphia 1896: 258.

(LIBERIA: MUHLENBERG MISSION.)

**Prepodesmus ornatus** (Peters)

*Polydesmus (Paradesmus) ornatus* Peters, Monatsb. Preuss. Akad. Wiss. Berlin 1864: 540.

*Cordyloporus aubryi* Attems (nec Lucas), Denkschr. Akad. Wiss. Wien **67**: 366. 1898.

*Cordyloporus ornatus* Brolemann, Arch. Zool. Exper. **65**: 109, figs. 110-113. 1926.

(CAMEROUN, GOLD COAST, AND CONGO.)

**Prepodesmus ornatus martinseni** (Attems)

*Cordyloporus aubryi* var. *martinseni* Attems, Denkschr. Akad. Wiss. Wien **67**: 367. 1898.

*Cordyloporus ornatus* var. *martinseni* Attems, Das Tierreich, Lief. **69**: 374. 1938.

**Prepodesmus ornatus interferens**, n. var.

*Cordyloporus ornatus ornatus* Attems (nec Peters), Das Tierreich, Lief. **69**: 374. 1938.

Differing from *ornatus* sens. str. in having the underside of the body, together with legs and antennae, dark brown instead of wine red, and in having on the poriferous keels a large, round, rose-red spot, which does not quite reach the anterior margin or in having these keels sometimes entirely red. Middorsal region always dark. A transverse mark on the collum and the tips of the second and third keels yellowish. Dorsum black except as noted.

Localities: Gaboon, Togo, Cameroun, and Belgian Congo.

**Prepodesmus pictus** Cook

*Prepodesmus pictus* Cook, Proc. Acad. Nat. Sci. Philadelphia 1896: 263. (TOGO.)

**Prepodesmus sulcatus** (Attems)

*Cordyloporus sulcatus* Attems, Denkschr. Akad. Wiss. Wien **67**: 364. 1898.

(LOCALITY UNKNOWN.)

**Prepodesmus tigrinus** Cook

*Prepodesmus tigrinus* Cook, Proc. Acad. Nat. Sci. Philadelphia 1896: 258.

(LIBERIA: MOUNT COFFEE.)

## TYLODESMINAE, n. subfam.

Proposed for those genera in which the gonopods lack an accessory branch from the femoral division.

Genus **Anisodesmus** Cook

*Anisodesmus* Cook, Proc. U. S. Nat. Mus. **18**: 99. 1895; Proc. Acad. Nat. Sci. Philadelphia 1896: 260.

Generotype: *Anisodesmus cerasinus* Cook.

**Anisodesmus cerasinus** Cook

*Anisodesmus cerasinus* Cook, Proc. U. S. Nat. Mus. **18**: 99. 1895; Proc. Acad. Nat. Sci. Philadelphia 1896: 260.

(LIBERIA, BOPORU, ST. PAUL RIVER.)

**Anisodesmus erythropus** (Lucas)

*Polydesmus erythropus* Lucas, Archiv Ent. **2**: 63, pl. 13, fig. 8. 1858.

*Polydesmus (Paradesmus) erythropus* Peters, Monatsb. Preuss. Akad. Wiss. Berlin 1864: 624.

*Cordyloporus serratus* Attems, Denkschr. Akad. Wiss. Wien **67**: 364. 1898.

*Orydesmus erythropus* Attems, Das Tierreich, Lief. **69**: 340. 1938.

(LIBERIA.)

Genus **Cheirodesmus** Cook

*Cheirodesmus* Cook, Amer. Nat. **30**: 416. 1896.

Generotype: *Cheirodesmus ater* Cook.

**Cheirodesmus ater** Cook

Fig. 5

*Cheirodesmus ater* Cook, Proc. Acad. Nat. Sci. Philadelphia 1896: 259.

(LIBERIA.)

**Cheirodesmus discolor** Cook

*Cheirodesmus discolor* Cook, Proc. Acad. Nat. Sci. Philadelphia 1896: 259.

(LIBERIA.)

Genus **Cordyloconus** Attems

*Cordyloconus* Attems, Das Tierreich, Lief. **69**: 380. 1938.

Generotype: *Paracordyloporus vitiosus* Attems.

**Cordyloconus vitiosus** (Attems)

*Paracordyloporus vitiosus* Attems, Zoologica **30** (3/4): 92, fig. 130. 1931.

*Cordyloconus vitiosus* Attems, Das Tierreich, Lief. **69**: 380. 1938.

(CAMEROUN.)

Genus **Doidesmus** Chamberlin

*Doidesmus* Chamberlin, Bull. Amer. Mus. Nat. Hist. **57**: 243. 1927.

Generotype: *Doidesmus explorator* Chamberlin.

**Doidesmus explorator** Chamberlin

*Doidesmus explorator* Chamberlin, Bull. Amer. Mus. Nat. Hist. **57**: 246, figs. 182-187. 1927.  
(BELGIAN CONGO.)

Genus **Graphidiochirus** Attems

*Graphidiochirus* Attems, Rev. Zool. Bot. Afr. **17**: 333. 1929.

Genotype: *Graphidiochirus spadix* Attems.

**Graphidiochirus spadix** Attems

*Graphidiochirus spadix* Attems, Rev. Zool. Bot. Afr. **17**: 333. 1929.  
(BELGIAN CONGO.)

Genus **Isodesmus** Cook

*Isodesmus* Cook, Proc. U. S. Nat. Mus. **18**: 99. 1895.

Genotype: *Isodesmus immarginatus* Cook.

**Isodesmus immarginatus** Cook

## Fig. 6

*Isodesmus immarginatus* Cook, Proc. U. S. Nat. Mus. **18**: 99. 1895.  
(LIBERIA.)

**Isodesmus interruptus** Cook

*Isodesmus interruptus* Cook, Proc. Acad. Nat. Sci. Philadelphia 1896: 260.  
(LIBERIA.)

**Morphotelus**, n. gen.

In this genus the tibiotarsus consists of two large laminate lobes the outer of which presents a margin sometimes more or less dentate or lacinate, the two lobes forming something of a calyx enclosing the much shorter, blade-like, and simple solenomerite. (See Figs. 7, 8.)

Genotype: *Cordylaporus mareesi* Carl.

**Morphotelus corruptus** (Attems)

*Cordylaporus corruptus* Attems, Rev. Zool. Bot. Afr. **30**: 45, figs. 24-25. 1937.  
(BELGIAN CONGO.)

**Morphotelus lacinosus** (Attems)

*Cordylaporus lacinosus* Attems, Rev. Zool. Bot. Afr. **30**: 46, fig. 26. 1937.  
(BELGIAN CONGO.)

**Morphotelus mareesi** (Carl)

*Cordylaporus mareesi* Carl, Rev. Suisse Zool. **17**: 300, pl. 6, fig. 2. 1909.  
(CENTRAL AFRICA.)

**Morphotelus sequens** (Chamberlin)

*Anisodesmus sequens* Chamberlin, Publ. Cult. Companhia Diamantes Angola, **10**: 84, figs. 40-44. 1951.  
(ANGOLA.)

**Morphotelus terreus** (Attems)

*Cordylaporus terreus* Attems, Rev. Zool. Bot. Afr. **30**: 43, fig. 23. 1937.

Genus **Paracordylaporus** Brolemann

*Paracordylaporus* Brolemann, Ann. Soc. Ent. France **84**: 563. 1916.

*Grallodesmus* Chamberlin, Bull. Amer. Mus. Nat. Hist. **57**, art. 4: 242. 1927.

Genotype: *Cordylaporus dilatatus* Carl.

**Paracordylaporus alternatus** (Karsch)

*Polydesmus alternatus* Karsch, Zeitschr. Ges. Naturw. **52**: 825. 1879.

*Cordylaporus alternatus* Attems, Denkschr. Akad. Wiss. Wien **67**: 367. 1898.

*Paracordylaporus alternatus* Brolemann, Ann. Soc. Ent. France **84**: 563. 1916.  
(WEST AFRICA.)

**Paracordylaporus camerunensis** (Attems)

*Cordylaporus camerunensis* Attems, Ann. Mus. Wien **41**: 20, fig. 27. 1927.

*Paracordylaporus camerunensis* Attems, Das Tierreich, Lief. **69**: 385. 1938.  
(CAMEROUN.)

**Paracordylaporus camerunensis papillatus** Attems

*Paracordylaporus camerunensis papillatus* Attems, Zoologica **30**, (3/4): (Heft 79): 93.  
(CAMEROUN.)

**Paracordylaporus dilatatus** (Carl)

*Cordylaporus dilatatus* Carl, Mem. Soc. Españ. Hist. Natur. **1**: 264, pl. 6, fig. 3. 1905.

*Paracordylaporus dilatatus* Brolemann, Ann. Soc. Ent. France **84**: 563. 1916.  
(SPANISH GUINEA.)

**Paracordylaporus malangensis** Chamberlin

*Paracordylaporus malangensis* Chamberlin, Publ. Cult. Companhia Diamantes Angola **10**: 55, fig. 47. 1951.  
(ANGOLA.)

**Paracordylaporus diplogon** (Chamberlin)

*Grallodesmus diplogon* Chamberlin, Bull. Amer. Mus. Nat. Hist. **57**: 242, figs. 167-172. 1927.  
(BELGIAN CONGO.)

**Paracordylaporus moeranus** (Attems)

*Cordylaporus moeranus* Attems, Ann. Mus. Wien **41**: 69, figs. 24-26. 1927.

*Paracordylaporus moeranus* Attems, Rev. Zool. Bot. Afr. **14**, (3): 345, figs. 50-57. 1929.  
(CENTRAL AFRICA.)

**Paracordylaporus pulcher** (Carl)

*Cordylaporus pulcher* Carl, Mem. Soc. Españ. Hist. Natur. **1**: 267, p. 6, fig. 5. 1905.

*Paracordylaporus pulcher* Brolemann, Ann. Soc. Ent. France **84**: 563. 1916.  
(SPANISH GUINEA, CABO SAN JUAN.)

**Paracordyloporus speciosus** Attems

*Paracordyloporus speciosus* Attems, Rev. Zool. Bot. Afr. 17: 342, figs. 48-49. 1929.  
(BELGIAN CONGO.)

Genus **Scolopopleura** Attems

*Scolopopleura* Attems, Ergeb. D. Zentr.-Afr.-Exped. 4: 302. 1912.

*Gitadesmus* Chamberlin, Bull. Amer. Mus. Nat. Hist., 57: 241. 1927.

Generotype: *Scolopopleura spinosa* Attems.

**Scolopopleura graciliramus** (Chamberlin)

*Gitadesmus graciliramus* Chamberlin, Bull. Amer. Mus. Nat. Hist. 57: 241, figs. 160-166. 1927.  
(BELGIAN CONGO.)

**Scolopopleura insignis** (Attems)

*Cordyloporus insignis* Attems, Ann. Mus. Wien 41: 71, figs. 28-29. 1927.

*Scolopopleura insignis* Attems, Das Tierreich, Lief. 69: 390, fig. 426. 1938. (CENTRAL AFRICA.)

**Scolopopleura limbata** Attems

*Scolopopleura limbata* Attems, Rev. Zool. Bot. Afr. 17: 348, figs. 58-60. 1929.  
(BELGIAN CONGO.)

**Scolopopleura limbata rubripes** Attems

*Scolopopleura limbata* var. *rubripes* Attems, Rev. Zool. Bot. Afr. 17: 350. 1929.  
(KIKWIT, BELGIAN CONGO.)

**Scolopopleura pokana** (Chamberlin)

*Gitadesmus pokanus* Chamberlin, Bull. Amer. Mus. Nat. Hist. 57: 241, figs. 160-166. 1927.  
(BELGIAN CONGO.)

**Scolopopleura pectinata** Attems

*Scolopopleura pectinata* Attems, Rev. Zool. Bot. Afr. 17: 352, fig. 64. 1929. (BELGIAN CONGO.)

**Scolopopleura pulcherrima** Attems

*Scolopopleura pulcherrima* Attems, Rev. Zool. Bot. Afr. 17: 350, figs. 61-63. 1929.  
(BELGIAN CONGO.)

**Scolopopleura spinosa** Attems

*Scolopopleura spinosa* Attems, Ergeb. D. Zentr.-Afr. Exped. 4: 302, figs. 3-6. 1912. (CONGO.)

Genus **Tyloidesmus** Cook

*Tyloidesmus* Cook, Amer. Nat. 30: 416. 1896.

*Lyrodesmus* Cook, Proc. Acad. Nat. Sci. Philadelphia; 1896: 259.

*Cordyloporus* Attems (in part), Rev. Zool. Bot. Afr. 17: 328. 1929.

*Pleuroarium* Attems (in part), Rev. Zool. Bot. Afr. 17: 332. 1929.

Generotype: *Tyloidesmus crassipes* Cook.

**Tyloidesmus albus**, n. sp.

Fig. 9

Agreeing in most features with *T. nigerrimus* Cook but contrasting in being nearly white throughout. The gonopods are of the form shown in Fig. 9. (LIBERIA.)

**Tyloidesmus amoebus** Cook

*Tyloidesmus amoebus* Cook, Proc. Acad. Nat. Sci. Philadelphia 1896: 259.  
(MUHLENBERG MISSION, LIBERIA.)

**Tyloidesmus crassipes** Cook

Fig. 3

*Tyloidesmus crassipes* Cook, Proc. Acad. Nat. Sci. Philadelphia 1896: 259. (LIBERIA.)

**Tyloidesmus nigerrimus** Cook

*Tyloidesmus nigerrimus* Cook, Proc. Acad. Nat. Sci. Philadelphia 1896: 259. (LIBERIA.)

**Tyloidesmus studeri** (Carl)

*Cordyloporus studeri* Carl, Rev. Suisse Zool. 21: 207, figs. 4-5. 1913.  
*Pleuroarium studeri* Attems, Rev. Zool. Bot. Afr. 17: 332. 1929. (SIERRA LEONE, LIBERIA.)

**Tyloidesmus studeri spectandus** (Attems)

*Pleuroarium studeri spectandum* Attems, Rev. Zool. Bot. Afr. 17: 332. 1929.  
*Cordyloporus studeri spectandus* Attems, Das Tierreich, Lief. 69: 376. 1938. (LIBERIA.)

**Tyloidesmus liberiensis** (Peters)

*Polydesmus (Paradesmus) liberiensis* Peters, Monatsb. Preuss. Akad. Berlin 1864: 540.  
*Cordyloporus liberiensis* Attems, Denkschr. Akad. Wiss. Wien 67: 368, pl. 5, fig. 107.  
*Pleuroarium liberiense* Attems, Rev. Zool. Bot. Afr. 17: 332. 1929. (LIBERIA.)

**Tyloidesmus viabilis**, n. sp.

Dorsum dusky brown, with no different coloration on any of the keels. Legs and antennae yellow. Three series of setae on the collum, apparently four in each series; two similar series of setae on the second tergite, and but one series on subsequent tergites, this series toward the anterior border of the metazonite. Keels moderately bent upward, more strongly upbent on posterior segments. Anal tergite proportionately longer and narrower than in *T. nigerrimus*. Anterior legs of male not obviously thickened as they are in *crassipes*.

Length of male, about 38 mm; width, 4.5 mm.

Locality: Liberia (Mount Coffee). Male holotype collected by F. C. Strand and two males by Collins in 1896. Types in U. S. National Museum.

## REFERENCES

- ATTEMS, CARL GRAFEN. *System der Polydesmiden*. Denkschr. Akad. Wiss. Wien **67** and **68** 1898.
- . *Diplopoden des Belgischen Congo*. *Polydesmoidea I*. Rev. Zool. Bot. Afr. **17** (3): 253-378. 1929.
- . *Polydesmoidea des Belgischen Congo. I Nachtrag*. Ibid. **30** (1): 19-70. 1937.
- . *Diplopoden des Belgischen Congo. Polydesmoidea. II Nachtrag*. Ibid. **31** (2): 224-225. 1938.
- . *Polydesmoidea II*. Das Tierreich **69**. 1938.
- BROLEMANN, H. W. *Essai d'une classification des Polydesmiens*. Ann. Soc. Ent. France **84**. 1916.
- CARL, JOHANN. *Diplopodes de la Guinee espagnole*. Mem. Soc. Españ. Hist. Nat. **1**: mem. 15, 261-284. 1905.
- . *Reise von Dr. J. Carl im Nordlichen Central-Afrik. Seengebiet. Diplopoden*. Rev. Suisse Zool. **17** (2): 281-365. 1909.
- CHAMBERLIN, RALPH V. *The Chilopoda and Diplopoda collected by the American Museum of Natural History Congo Expedition*. Bull. Amer. Mus. Nat. Hist. **57**: (4): 177-240. 1927.
- . *On Diplopoda of North-East Angola*. Publ. Cult. Companhia de Diamantes Angola **10**: 63-94. 1951.

- COOK, ORATOR F. *West African Diplopoda of the suborder Polydesmoidea collected by William Astor Chanler*. Proc. U. S. Nat. Mus. **18**: 81-111. 1895.
- . *A new diplopod fauna in Liberia*. Amer. Nat. **30**: 416. 1896.
- . *Summary of New Liberian Polydesmidae*. Proc. Acad. Nat. Sci. Philadelphia 1896.
- . *On the Xyodesmidae, a new family*. Brandtia **4**: 15-17. 1896.
- KARSCH, F. *West Afrikanische Myriopoden und Arachniden gesammelt von Herrn Stabsarzt Dr. Falkenstein*. Zeitschr. Ges. Naturw. **3**: 825-837. 1879.
- . *Zwei neue Polydesmiden von Quango*. Berliner Ent. Zeitschr. **25**: 287. 1881.
- LUCAS, H. *Description des Arachnides et des Myriopodes qui habitent le Gabon*. Archiv Ent. **2**: 61-69. 1858.
- PETERS, W. C. H. *Übersicht der im Konigl. zoolog. Museum befindlichen Myriopoden*. Monatsb. Preuss. Akad. Wiss. Berlin 1864: 529-551.
- PORAT, C. C. VON. *Myriopoder fran West-Och Syd-Afrika*. Bihang Svensk. Akad. **18** (7): 5-51. 1892.
- . *Zur Myriopodenfauna Kamerun*. Ibid. **20** (5): 1-90. 1894.
- SILVESTRI, F. *I Diplopodi, I, parte systematica*. Ann. Mus. Civ. Stor. Nat. Genova (2), **16**.
- . *Nuove specie de Diplopodi*. Bull. Mus. Zool. et Anat. Comp. Torino **22**: 560. 1907.
- . *Relaz. scient., Miriopodi. Il Ruwenzori 1*: 317-318. 1909.

## PROCEEDINGS OF THE ACADEMY AND AFFILIATED SOCIETIES

## PHILOSOPHICAL SOCIETY OF WASHINGTON

## 1334TH MEETING

The 1334th meeting was held in the auditorium of the Cosmos Club, October 20, 1950, President KRACEK presiding.

Program: PHILIP H. ABELSON, Carnegie Institution of Washington: *Isotope tracers: Past, present, and future*.—A brief history was given of the development of isotope tracers, their nature and methods of production. It was pointed out that there are now about 1,200 isotopes but that only about 15 are important from the viewpoint of radioactivity. These tracer elements have, owing to present large scale production methods, been utilized widely in medicine, biology, agriculture, plant physiology, etc. Their most publicized use in medicine has been disappointing primarily because of the lack of sufficient care in protecting healthy cells. Tracer elements have

also been used in the measurement of friction, in the construction of thickness gauges, process control, measurement of time, in diffusion studies, etc.

The speaker suggested that in the future isotopic tracers would be used primarily in the studying of metabolic pathways, relation between structure and function, conversion of one organism to another and the division of cells. If one cell is once understood, the possibility of understanding  $10^{15}$  cells will not be so remote. (*Secretary's abstract*.)

## 1335TH MEETING

The 1335th meeting was held in the auditorium of the Cosmos Club, November 3, 1950, President KRACEK presiding.

Program: GEORGE GAMOW, George Washing-

ton University: *The first half hour of creation.*—Methods involving radioactive decay and the age of the ocean from the thickness of salt deposits gave 3 to 4 billion years. The age of the rocks, rate of recession of the moon, and the age of the sun and stars gave about 2.5 billion years. If the present expanding universe is contracted at the same rate as the present expansion until all the galaxies are united, a figure of 1.8 billion years is obtained.

At the time of the creation, the universe was visualized as consisting of only neutrons, protons, and electrons at an average density of  $10^{-3}$  grams/cm<sup>3</sup> at a temperature of about  $10^{90}$ K. Upon cooling, these particles by combination produced all the elements in the relative abundances now known. In this cooling process, all the neutrons were supposed to have disappeared in about 35 minutes, so that the formation of the elements was completed within this time. In various positions within the universe local variations from this relative abundance curve are found, but these were ascribed to different forces of attraction of the bodies in question. When and how the various galaxies were formed has not been quite so clear because of turbulence and other factors entering into their formation. (*Secretary's abstract.*)

#### 1336TH MEETING

The 1336th meeting was held in the auditorium of the Cosmos Club, November 17, 1950, Vice-President McNISH presiding.

Program: JOHN STRONG, Johns Hopkins University: *The new Johns Hopkins ruling engine.*—The speaker first described some of the experiences which Rowland and Anderson had in making and working with the older Rowland engines. In these engines the diamond point is moved back and forth over the grating blank which is advanced by rotating a single screw. The new Johns Hopkins ruling engine, however, has two screws which support only the diamond point, and the grating blank is moved back and forth under this point to rule the grating lines. The methods of making the bearings, screw, and dividing head were all discussed separately. To secure straight line motion a conically shaped bearing surface was used. The two screws after turning were each lapped about 2,000 hours to give a uniform pitch and diameter. The process used for making and lapping the dividing head was also described. This new engine is capable of

ruling two gratings per week with 14,400 lines to the inch. The ghost intensities have been of the order of 1/600 to 1/1,000 in the first 25 or 30 gratings. A motion picture of the ruling engine in motion was then shown. (*Secretary's abstract.*)

#### 1337TH MEETING

The 1337th meeting, the 80th annual meeting, was held in the auditorium of the Cosmos Club, December 1, 1950, President KRACEK presiding.

The report of the Treasurer, LAWRENCE A. WOOD, showed a total income during the year of \$1,969.31. The expenses were \$1,395.17, leaving a net gain of \$574.14. The total estimated assets of the Society were \$18,324.51 as compared with \$17,215.85 the year before. The Auditing Committee reported that the records and report were correct.

The joint report of the Secretaries showed a net gain of 8 new members during the year and an active membership of 540.

The report of the Committee on Elections indicated that the following officers had been elected:

President: E. U. CONDON  
 Vice Presidents: A. G. McNISH, A. I. MAHAN  
 Recording Secretary: L. A. WOOD  
 Treasurer: T. J. CARROLL  
 Members at Large of the General Committee:  
 CHESTER PAGE, W. R. DURYEA

Program: L. R. HAFSTAD, Atomic Energy Commission: *The reactor program of the Atomic Energy Commission.*—The history of atomic fission was traced from the first artificial disintegration of lithium in 1932 up to the present. A reactor was defined as a device for converting atomic energy into energy of useful forms. The difficulties encountered in building such reactors were enumerated. Several different types of reactors were mentioned. These were the production reactor, the research reactor and the mobile power reactor. The present reactor program consists of building four reactors. The cost of installing reactors was estimated at \$1,400 per kilowatt, while other more conventional power sources cost approximately \$200/kw. In closing the speaker suggested that with the present increase in coal prices and decreasing costs of reactors the two price curves might some day cross.

The newly elected President, Mr. CONDON, was conducted to the chair by Past Presidents

STIMSON and JOHNSTON and was presented the gavel by the Retiring President, Mr. KRACEK. (*Secretary's abstract.*)

## 1338TH MEETING

The 1338th meeting was held in the auditorium of the Cosmos Club, December 15, 1950, Vice-President McNISH presiding.

Program: CHESTER H. PAGE, National Bureau of Standards: *The mathematical theory of communication* (published under the title *Information theory* in this JOURNAL 41: 245-249. 1951).—The quantitative measure of information is introduced in terms of the minimum number of symbols needed to distinguish a particular message from all others of a given set. The set is usually described as an ensemble (finite or infinite) of messages generated by a specified stochastic process. The message probabilities resulting from this process lead to an average information per message that is analogous to entropy in statistical mechanics.

The rate of communication over a noisy channel is derived, and Shannon's theorem (that the full channel capacity can always be utilized) is explained. The paper concludes with results relative to communication by continuous functions, and the engineering formula relating channel capacity to bandwidth and signal/noise power ratio. (*Author's abstract.*)

## 1339TH MEETING

The 1339th meeting was held in the auditorium of the Cosmos Club, January 12, 1951, President CONDON presiding.

The Retiring President, FRANK C. KRACEK, delivered the presidential address on *The application of thermochemistry to geophysical problems*. He showed how determinations of the heat changes which accompany chemical reactions and changes of state furnish thermodynamic data required for evaluating the relative stabilities and conditions of formation of minerals in their various associations in nature. Detailed applications were made to the formation of quartz, jadeite, and feldspar. (*Secretary's abstract.*)

## 1340TH MEETING

The 1340th meeting was held in the auditorium of the Cosmos Club, January 26, 1951, Vice-President MAHAN presiding.

Program: J. W. GRAHAM, Department of Ter-

restrial Magnetism, Carnegie Institution of Washington: *The determination of the earth's field in geologic time.*—Mr. Graham described measurements of the magnetization of magnetite particles in sedimentary rocks in different parts of the United States. These furnish information regarding the magnetic field existing at the time the rocks were cooled through the Curie point. There was found to be good evidence that the earth's field had not exceeded 10 gauss at any time since the deposits were laid down several hundred million years ago, and that the direction of magnetization under certain circumstances is retained for this period of time. However, it is difficult to understand the reason for magnetization observed in some instances which is opposite to that of the earth's present field. It is thought to be due not to an actual reversal of the earth's field or to continental drift but possibly to chemical changes in a 2-component system. (*Secretary's abstract.*)

## 1341ST MEETING

The 1341st meeting was held in the auditorium of the Cosmos Club, February 9, 1951, Vice-President MAHAN presiding.

Program: GLENN D. CAMP, Operations Evaluation Group, U. S. Navy: *Operations research: A quantitative aid to executive decision.*—Operations research, under that name, had its origins in England in 1940 as part of the anti-aircraft defense effort. Its introduction into the United States came as part of the antisubmarine warfare. An operation is defined as a purposeful activity usually involving large aggregates of men and machines. Operations research is an applied science that is concerned with analyzing and maximizing the performance of any set of operations designed to achieve a specified goal. It is characterized by the use of teams of scientists representing diverse fields who combine conclusions into a unified recommendation directly to a high-level executive. Isomorphism in diverse and apparently unrelated operations is thoroughly exploited. Its greatest successes thus far have been in military operations, where nothing of the sort had been previously applied. It is rapidly expanding into civilian operations, for example including problems of mass production, warehousing, traffic control, and congestion of communication channels. A text on the subject by Morse and Kimball will soon be published. (*Secretary's abstract.*)

## 1342D MEETING

The 1342d meeting was held in the auditorium of the Cosmos Club, February 23, 1951, President CONDON presiding.

Program: E. MAXWELL, National Bureau of Standards: *Recent developments in superconductivity*.—One very recent discovery has been the addition of osmium and ruthenium to the list of superconductors by workers in Cambridge, England. The superconducting elements are chiefly found in two regions in the periodic table. A periodic table was shown which gave, for the superconductors, the temperature of transition into the superconducting state and, for the other elements, the lowest temperature at which an unsuccessful search for superconductivity had been made. Isotope effects on the transition temperature, have within the past two years been discovered independently at the National Bureau of Standards and at Rutgers University. In mercury and tin the higher the average isotopic weight the lower is the transition temperature for a given magnetic field. Recent theories of Frolich in England and Bardeen at the Bell Telephone Laboratories have attempted to explain superconductivity in terms of an electron level of lower energy than the normal conduction state and to ascribe the origin of this level to the interaction of lattice vibrations and electron waves. Colored motion pictures of classical experiments in superconductivity were shown. These were taken at the National Bureau of Standards and showed a magnet floating above a superconducting tin dish and a magnet repelled by a superconducting tin sphere. Repulsion ceased when the temperature was raised above that of the transition. (*Secretary's abstract.*)

## 1343D MEETING

The 1343d meeting was held in the auditorium of the Cosmos Club, March 9, 1951, President CONDON presiding.

Program: EARL K. FISCHER, National Bureau of Standards: *High-speed motion pictures as a research tool*.—Whereas normally motion pictures are taken at speeds of 16 and 24 frames/sec., high speed is defined as any rate between 250 and 10,000 pictures per sec., and ultra-high speeds refer to rates above 10,000 per sec. Rates as high as  $10^7$  per sec. are sometimes achieved but these methods are not strictly image-forming camera devices, which usually operate at a rate

less than  $10^4$  per sec. Top speed of Eastman cameras, for example, is 3000 frames/sec., or roughly a 200-fold speedup when projected at a rate of 16 per sec. Comparisons of the image formation in Eastman, Fastax, and Edgerton cameras were made. Motion and still pictures were shown illustrating the high speed shuttle action in a loom, the formation, oscillations and splashing of waterdrops. Comparisons were made of surface tension measurements of surface tension of several soaps by the oscillating drop, the ring, and the capillary rise methods. Mr. Fischer expressed the opinion that the modest cost (\$2,000–\$10,000) and comparatively light weight (30–50 lb.) qualified high speed motion pictures as an eminently practical research tool. (*Secretary's abstract.*)

## 1344TH MEETING

The 1344th meeting of the Society was the occasion of the twentieth Joseph Henry Lecture. It was held in the auditorium of the Cosmos Club, March 23, 1951, President CONDON presiding.

Program: LYMAN SPITZER, Princeton University: *The formation of stars* (published under the title *The birth of stars from interstellar clouds* in this JOURNAL 41: 309–318. 1951).—Stars may be grouped in two main classes: primeval stars and cloud stars. Primeval stars are observed in systems where there are no clouds of interstellar matter. Presumably they began their existence about  $3 \times 10^9$  years ago and have been diminishing in brightness ever since. The brightest are about as bright as  $10^3$  suns, and their velocities are found to be in the range 60–180 km/sec. The cloud stars, on the other hand, according to present ideas, are being formed continually out of the matter in interstellar space. This matter, which has a total mass about equal to that of the matter in the stars, has an average density of about one hydrogen atom per cubic centimeter. The cloud stars are found where clouds of interstellar matter are known to be present from other evidence. They have velocities in the range 10–30 km/sec. and the luminosity of the "supergiant" members of this class may be as much as  $10^5$  suns. Two small grains of interstellar matter can be pushed towards each other by radiation pressure, since each screens the other from the pressure. When this process is repeated a critical size may be reached above which the gravitational attraction is sufficient to



build up the particles into a protostar. Condensation gives rise to heating and the release of atomic energy by atom-building. Of course this is a relatively rare event, but when it happens a new star is found. (*Secretary's abstract.*)

## 1345TH MEETING

The 1345th meeting was held in the auditorium of the Cosmos Club, April 6, 1951, President CONDON presiding.

Program: RENE A. SPITZ, M.D., New York Psychoanalytical Institute: *Methodological consideration in psychoanalytical research.*—Psychoanalysis, a development of the present century, finds difficulty in controlling the conditions of an experiment. Freud was the first physician to study carefully the behavior of irrational people. He developed two methods for discovering the event or sensation which was at the root of the patient's difficulties. The first, called catharsis and based on hypnotism, was abandoned in favor of "free association" in which the patient responds to various words with the first idea which comes to his mind. In this manner it has been found that the formative period for an individual ego is in the first months of life. Mr. Spitz's researches have concerned children in the first 18 months, the preverbal stage. Events at ages earlier than 18 months can not be remembered but may have extremely important consequences as far as the health and personality are concerned, especially events between the ages of 6 and 12 months. Moving pictures showed the striking comparison between children in a penal nursery where the children were normally in constant contact with their mothers and in a foundling home where a nurse had to care for about ten children. Effects of the absence of the mother for periods of several months were likewise shown. In the penal nursery the children developed normally but in the foundling home mortality was extremely high (33 percent in the first two years), diseases rampant, and both physical and mental development stunted permanently. Absence of the mother for more than 3 months also produced irreversible changes in the child but up to this time recovery was rapid on the return of the mother. (*Secretary's abstract.*)

## 1346TH MEETING

The 1346th meeting was held in the auditorium of the Cosmos Club, April 20, 1951, President CONDON presiding.

Program: ERNEST POLLARD, Yale University: *The physics of viruses.*—Viruses have three notable characteristics, namely, the ability to reproduce (which they share with living matter), the production of symptoms in the host, and the production of antibodies in the host. When a virus enters a cell it appears to dominate the activity of the cell and reproduces itself at a very great rate—for example, a multiplication by a factor of  $10^{12}$  in 12 hours has been observed in some instances. The medical approach to virus diseases has been to introduce the virus in some modified form which is not particularly harmful and which does not reproduce too rapidly, and to rely on the formation of antibodies to destroy not only the modified virus but also more destructive viruses of a similar nature. The electron microscope has shown the size of a virus particle to range from 150 Angstroms (foot and mouth disease) to several thousand (cow pox). Plant viruses, such as the tobacco mosaic virus, are apparently simpler than bacterial viruses, can sometimes be crystallized, and may consist of a large single molecule.

Mr. Pollard's researches have involved the destruction of viruses by bombardment with deuterons from a cyclotron, and a measurement of their effective cross sections. It is concluded that a single hit on a plant virus is sufficient to inactivate it, but that the bacterial viruses have regions not inactivated by a direct hit. The observations are consistent with a rod-structure for plant viruses, and a rod-structure with a head for the bacterial viruses. (*Secretary's abstract.*)

## 1347TH MEETING

The 1347th meeting was held in the auditorium of the Cosmos Club, May 4, 1951, Vice-President McNISH presiding.

Program: GORDON F. HULL, Dartmouth College and the Office of Naval Research: *The properties of microwaves.*—The lecture was a demonstration lecture in which the similarities between the physical properties of three centimeter microwaves and usual optical waves were pointed out. The microwave source was a cavity type resonating tube and the receiver of the crystal type. The reflecting and transmitting properties of various materials were first shown. To establish that microwaves could be made to interfere, Young's double-slit experiment and a Michelson Interferometer were assembled. The beam splitter for the interferometer was made of

a system of equally spaced wires and the full reflecting plates were of brass. Alternate increases and decreases in the signal could easily be heard when one of the brass plates was moved slowly in one direction. Fresnel and Fraunhofer diffraction were both detectable when various restricting apertures were used. A Fresnel zone plate made from a series of concentric sheet metal rings showed focusing properties which could easily be detected. To show that micro-waves could be refracted, a large paraffin prism and a prism constructed from a series of parallel equally spaced triangular plates were used. The paraffin prism had a refractive index greater than unity while the parallel plate prism had an effective refractive index less than unity. It was shown also that lenses could be made either from refractory materials or from a series of plane parallel metal plates of the correct shape. The properties of birefringent materials were discussed and both quarter and half wave plates were made. In closing, Mr. Hull showed some specially prepared plywood samples having quite striking transmitting characteristics. (*Secretary's abstract.*)

## 1348TH MEETING

The 1348th meeting was held in the auditorium of the Cosmos Club, May 18, 1951, Vice-President McNISH presiding.

Program: LOUIS N. RIDENOUR, University of Illinois: *Present and future trends in electronics.*—Electronics may be said to have had its birth with the invention of the 3-element "audion" vacuum tube by De Forest in 1906. This was, of course, based on the Edison effect of 1883, almost the only truly scientific discovery of the great inventor. The Fleming valve was another antecedent of the "audion" also. There were spurts of activity during both world wars, with radio broadcasting following the first and popular television the second. The greatest total output of electronic equipment was in 1944 when about 4.5 billion dollars worth of equipment was produced. The number of television receivers in operation, estimated at about 10,000 in 1946, is now about 13 million, with a production capacity of about 8 million a year realized in 1950. In radio and television receivers quality and reliability are definitely sacrificed in favor of low prices; in the telephone system the reverse is true, where submerged repeaters, for example, may be expected to remain in operation 20 years without attention. Electronic equipment is still

not sufficiently reliable for central office switching or for local line repeaters. The trend in equipment is to reduce the size of the chassis and the vacuum tubes. Since power dissipation is not much changed temperature rises are higher.

The approximate limit of complexity seems to have been reached in the ENIAC digital computer and the transcontinental telephone line, each of which involves the functioning of about 18,000 vacuum tubes. The announcement of the transistor in 1948 by Bardeen and Brattain of the Bell Telephone Laboratories gives promise of a more reliable and satisfactory element than the vacuum tube. Mr. Ridenour closed by predicting that, whereas the vacuum tube permits machines about 100 times as complex as mechanical elements, this number may be raised by another factor of 100 if we can get rid of vacuum tubes by some such device as the transistor.

It was announced that the meeting was the last of the season and that Friday night would continue to be the regular meeting night next season, in view of a mail vote of the membership which gave a preference of 100-45 for Friday. (*Secretary's abstract.*)

## 1349TH MEETING

The 1349th meeting was held in the auditorium of the Cosmos Club, October 12, 1951, Vice-President McNISH presiding.

Program: R. E. GIBSON, Johns Hopkins University Applied Physics Laboratory: *An introduction to the natural philosophy of guided missiles.*—Mr. Gibson, a former president of the Society, pointed out that our Society was founded in an era when it was possible for one man to understand, discuss, and even make valuable contributions to several distinctly different branches of science. As the Society has grown older the various sciences have grown apart in becoming more and more specialized. However, in the mid-twentieth century a reverse trend has become apparent, and because of the development of unifying generalizations there is less need of pure memory of facts than formerly. This makes it possible to consider again natural philosophy, which includes an understanding and an organized basis for explaining the phenomena of nature. An accelerated growth in technology has also been accompanied by great progress in scientific understanding.

Weapons—military tools for a specific purpose—have had as their aim the removal of the fight-

ing man further and further from actual hand-to-hand contact. The effort is to strike a blow and to avoid retaliatory blows. Logical development of anti-aircraft artillery and of interceptor planes was bound to lead inevitably to the guided missile. Two features of missile research are the necessity for simulation of flight conditions by wind tunnels, vacuum chambers, and models and the extensive use of telemetering. A demonstration of telemetering was presented and moving pictures of take-offs of several types of guided missile. (*Secretary's abstract.*)

## 1350TH MEETING

The 1350th meeting was held in the auditorium of the Cosmos Club, October 26, Vice-President McNISH presiding.

Program: FRANCIS O. RICE, Catholic University: *Recent advances in free radical chemistry.*—The existence of free radicals was demonstrated experimentally for the first time by Paneth in 1929 who was able to remove a lead mirror by free methyl radicals in a stream of gas. Since then a number of free radicals have been studied. They include: methyl ( $\text{CH}_3$ ), methylene ( $\text{CH}_2$ ), ethyl ( $\text{C}_2\text{H}_5$ ), hydroxyl ( $\text{OH}$ ), imine ( $\text{NH}$ ), and several others. They are stable, with dissociation energies exceeding 100 kcal per mole in most cases. However, they are extremely reactive. The methyl radical combines with itself to form ethane so rapidly that its half life is only about 6 milliseconds. The methylene radical similarly forms ethylene in about the same time. Combination of free radicals with metallic mirrors a few atoms thick is a reaction often used in studying them. This reaction will not proceed if the metallic film is thick enough to form crystallites or if the surface is contaminated. Free radical theory has been very successful in explaining the amounts of hydrocarbons in equilibrium with each other at high temperatures.

If the imine radical is condensed on a tube maintained at liquid air temperatures a vivid blue solid of unknown structure and composition is formed. This undergoes a transition to a white solid, ammonium azide ( $\text{NH}_4\text{N}_3$ ), with the evolution of heat at a temperature of  $-125^\circ\text{C}$ . A demonstration of these solids and the transition was presented. Colors in the atmospheres of some of the planets may have a similar origin. (*Secretary's abstract.*)

## 1351ST MEETING

The 1351st meeting was held in the auditorium of the Cosmos Club, November 9, 1951, Vice-President McNISH presiding.

Program: ARTHUR E. RUARK, Johns Hopkins Institute for Cooperative Research: *How to understand relativity.*—Mr. Ruark, former Corresponding Secretary of the Society, described experiments conducted by one observer Robert in a frame of reference F and other experiments conducted by another observer Mack in a frame of reference F' moving along the x-axis of frame F with a velocity V. The results of the experiments conducted by Robert should be found to be the same as the results of the experiments conducted by Mack, including determinations of the velocity of light by each observer. The consequences of this statement, which partakes somewhat of the nature of an assumption or axiom, are the Lorentz transformation, the Fitzgerald contraction, and the other familiar results of relativity theory.

Attention was given to the electromagnetic field of a charge in uniform motion, and to the behavior of simple clocks, as for example a particle rotating about a center with a uniform angular velocity, as observed by Robert and by Mack. The difference in the clock-readings of the two observers is exactly balanced by the difference in measured distances, to give the same measured velocity of light. There was also discussion of a comparison of the times of events separated in space and of the synchronization of separated clocks. (*Secretary's abstract.*)

## 1352D MEETING

The 1352d meeting was held in the auditorium of the Cosmos Club, November 30, 1951, Vice-President McNISH presiding.

Program: KENNETH S. COLE, National Naval Medical Center: *Progress in biophysics.*—The speaker pointed out that biophysics can be traced back to ancient origins and that many men well known for their contributions to classical physics had conducted investigations in biological physics as well. These included such men as Gilbert, Hooke, Franklin, Galvani, Young, Brown, Poiseuille, Mayer, Fick, Helmholtz, Maxwell, and Weber. Of these Gilbert, Young, Poiseuille, Mayer, and Helmholtz actually had M.D. degrees. It is not generally remembered that Hooke was the originator of the

theory of biological cells or that Franklin first proposed that the body was cooled by the heat of evaporation of perspiration.

Modern biophysics, as compared with biochemistry, for example seemed to make relatively slow progress prior to World War II. Since then there has been a considerable increase in activity and some appreciable accomplishment. Three branches may be recognized: fundamental, applied, and technical. In fundamental biophysics studies are made of physical problems in biology. Certain questions are asked by performing a certain experiment and certain answers are given. A well-trained physicist is usually required to formulate the questions to ask and to interpret the answer that is given. Illustrative examples are nerve currents, the nature of cell-membrane, rise of sap in trees, the sphericity of sea urchin's eggs, and the physical characteristics of muscle. Applied biophysics has been concerned with such topics as brain waves, skin temperatures, physics of the ear, and cybernetics to mention a few. Technical biophysics has called on physicists to design, build, and operate physical tools for the biologist.

The book *American men of science* lists only 49 men claiming a major interest in biophysics; about 140 more claim it as a secondary or tertiary interest. However the teaching of biophysics is expanding rapidly and there are about a dozen institutions now granting a Ph.D. in biophysics. (*Secretary's abstract.*)

#### 1353D MEETING

The 1353d meeting, the 81st annual meeting, was finally called to order by Vice-President McNISH at 8:52 p.m. on December 14, 1951, in the auditorium of the Cosmos Club. Circumstances were most unusual. Owing to a severe storm and general disruption of transportation, only 17 members were present. Owing to the absence of the Secretary no report was presented.

The Treasurer's report, presented by Mr. Carroll, showed expenditures of about \$1,673 and a net gain for the year of \$650. The number of members of the Society was reported to have increased during the year from 541 to 560. The Auditing Committee's report was favorable.

The report of the Committee on Elections was as follows:

President: A. G. McNISH  
 Vice-Presidents: A. I. MAHAN, S. E. FORBUSH  
 Corresponding Secretary: B. L. WILSON

Treasurer: T. J. CARROLL  
 Members at Large of General Committee:  
 L. MARTON, H. C. BEAMAN

Program: E. R. PIORE, Office of Naval Research: *The mobilization of American science.*

#### 1354TH MEETING

The 1354th meeting was held in the auditorium of the Cosmos Club, January 4, 1952, President McNISH presiding.

Program: R. B. KERSHNER, Johns Hopkins University Applied Physics Laboratory: *Foundations of arithmetic.*—Arithmetic, as commonly taught, has been little more than a compendium of observed facts regarding numbers. Modern advances perhaps should be treated as number theory. Numbers originated as a series of different grunts. Questions of how far and how long were answered by comparison with standard lengths by counting the number of standard lengths in the unknown. Fractured standards then led to fractions and debits led to negative numbers. Geometry was given axiomatic treatment by Euclid and this has persisted ever since. Number theory, however, was almost nonexistent until it become obvious after 1800 that fundamental concepts had to be clarified, since direct contradictions were being obtained. Careful definition of fundamental terms and ideas was required, and this had to be followed by proof of the existence of the terms defined.

Dr. Kershner stated that the basic undefined terms in number theory could be reduced to two, namely: "set of elements" and "ordered pair." He showed how these could be used to define rigorously the concepts Cartesian product, relation, function, and operation.

A scientific arithmetic is made possible by these definitions. Three axioms suffice to set up the set of positive integers, for example. They are: (1) for every element in the set there is a successor; (2) no element has the integer 1 as successor; and (3) any subset containing the integer 1 and satisfying the first two axioms is identical with the set of positive integers itself. All the operations of integers commonly regarded as intuitive can be defined in terms of these axioms. (*Secretary's abstract.*)

#### 1355TH MEETING

The 1355th meeting was held in the auditorium of the Cosmos Club, January 18, 1952, President McNISH presiding.

Program: H. K. HARTLINE, Johns Hopkins University: *The electrical activity of optic nerve fibers.*—The speaker pointed out that the cells which make possible the existence of an animal in a complex environment are those of the central nervous system. The entire nervous system is the aggregate of living cells having long filamentous nerve fibers a few microns in diameter. The function of these fibers, which display irritability developed to a remarkable degree, is to transmit signals over long distances in the animal. A stimulus on the far end sets up local chemical changes which produce local electrical currents. These, in turn, stimulate adjacent regions. This process proceeds at a rate of many meters per second. Since the wave passing along a nerve fiber is accompanied by small electrical disturbances, the response can be measured. The nature of the response to an external influence such as visible light is such that either trains of discrete impulses all rather uniform in size are transmitted or nothing at all is transmitted along a given fiber. The sensibility of nerve fiber is extremely limited and each fiber responds to only one kind of signal. Thus many different kinds of fibers, each of which responds to only one stimulus, are required.

Measurements of the response of the optic nerve fibers of the king crab, squid, and house fly were described. By reducing the area of the spot of visible light falling on the receptor element of the eye of the crab it is possible to stimulate a single cell. Oscillograms showing the signals transmitted from the receptor along the nerve fiber for steady and intermittent light of different intensities were shown. The delay between the stimulus and the electrical response was shown and it was pointed out that the eye obeys the reciprocity law better than photographic plates for short flashes of light. Single element receptors were shown to respond to a range of intensity of  $10^4$  compared to the range of  $10^9$  for the more complicated human eye. Experiments in which a weak electrical current is passed through an optic nerve fiber attached to a receptor stimulated by light of low intensity show the two effects are additive provided the polarity is correct. Some fibers respond steadily to prolonged light, some only at the beginning and ending of the interval of illumination and others only at the end of the interval. The signals from individual receptors pass along fibers to junctions of various

types of neuron cells where the information from different cells is compared and processed before being transmitted to the brain. (*Secretary's abstract.*)

## 1356TH MEETING

The 1356th meeting was held in the auditorium of the Cosmos Club, February 1, 1952, President McNISH presiding.

Program: KURT S. LION, Massachusetts Institute of Technology: *Physics in vision and fatigue.*—Since there is no agreement on the definition of fatigue, it is not surprising that different laws relating to fatigue are found when different types of test are used. The main question seems to be whether the observer insists on some direct type of experiment or whether he allows measurement of some associated phenomenon. Carmichael and his coworkers have taken the former viewpoint, while Lukies and his collaborators have made observations of the latter type. Following the idea of Parry Moon that visual fatigue is muscular, the researches conducted by the speaker have been concerned with the 6 extrinsic muscles rotating the eyeballs about a vertical axis. It is found that a potential difference between the temples is developed as the eyes rotate. It is found to be closely proportional to the angle of rotation, zero when the eyes are looking straight ahead, and reverses polarity when they are moved from left to right. Potentials up to about 30 microvolts are found. Recorders with associated electronic circuits are arranged to give position, velocity, and acceleration, the latter being obtained by the use of differentiating circuits.

It is found that the actual velocity is constant to a first approximation, lower average velocities being obtained as a series of steps with no change of position between the steps. Motion toward the center was found to be at least 30 percent faster than motion away from the center. The individual is unable to control the actual velocity by conscious effort. From the fact that the acceleration records show no decrease with continued rotation of the eyes it is concluded that there is no decrease of force and consequently no fatigue of the muscles. There is thought to be considerable feed-back of some by-products of muscular activity (1) on the muscle itself and (2) on the central nervous system which is the motivating cause of the muscle action. No corre-

lation between the blinking rate and fatigue is found. Both visual and nonvisual tasks show a falling off of accuracy with decreased levels of illumination. (*Secretary's abstract.*)

## 1357TH MEETING

The 1357th meeting was held in the auditorium of the Cosmos Club, February 15, 1952, President McNISH presiding.

Program: J. W. BEAMS, University of Virginia: *Some recent developments in the production of high rotational speeds and their application.*—The pioneer work of Svedberg and Nichols led to the development of the self-balancing ultracentrifuge in 1934. With this equipment molecular weights can be determined over the complete range from 2, for hydrogen, to hundreds of millions, for some viruses. Commercial ultracentrifuges are now available and are approaching the stage of push-button control. For accurate work it is now recognized that studies of the rate of sedimentation are inadequate and equilibrium must be attained. Accurate temperature control, sometimes for several days, is required.

High rotational speeds are obtainable from synchronous motors with magnetically supported rotors and with rotating magnetic fields furnished by currents from oscillators. At 20,000 revolutions per second the speed can be maintained constant within 1 part in 10 million. The friction and windage can be reduced so much that a free-spinning rotor will decelerate at the rate of only about one revolution per second per day. Many different types of experiments can be performed with mirrors rotating at these speeds.

Studies have been made of the adhesion and tensile strength of thin films on the surfaces of high-speed rotors. The tensile strength is independent of thickness until a certain critical thickness is reached. Below the critical thickness the tensile strength increases rapidly as the thickness is decreased. Other studies have been made of the mobility and identification of ions in electrolytes. Balls as small as 1 mil. in diameter can be rotated at ultra-high speeds. (*Secretary's abstract.*)

## 1358TH MEETING

The 1358th meeting was held in the auditorium of the Cosmos Club, February 29, 1952, President McNISH presiding.

Program: ELIAS BURSTEIN, Naval Research Laboratory: *Optical properties of diamond, sili-*

*con, and germanium.*—After discussing the electron configurations of the three substances, the speaker presented graphs of the absorption as a function of wavelength. Attention was also given to the dielectric properties, refractive indices, and energy levels. The specific impurity, as yet unidentified, present in type I diamonds gives absorption in the region 6–10 microns as well as that which is easily accounted for as being due to lattice vibrations. It is transparent in the far infrared and consequently is useful for windows in infrared equipment. Germanium has useful transmission from 2–15 microns and probably also at wavelengths greater than 40 microns. Absorption measurements give information concerning the semiconducting states present in the different materials and about the processes involved. The mobility of electrons in a semiconductor is found to be about three times that of "holes" involved in conduction. (*Secretary's abstract.*)

## 1359TH MEETING

The 1359th meeting was held in the auditorium of the Cosmos Club, March 14, 1952, President McNISH presiding.

Program: THORNTON PAGE, Operations Research Office, Johns Hopkins University: *Density of matter in the universe.*—The speaker sketched the early astronomical developments by which the observations of Brahe led to the formulation of Kepler's Laws, particularly the one stating that the cube of a planet's distance from the sun is proportional to the square of its period. Newton's work showed that the sum of the masses of the sun and the earth was a factor of the proportionality constant. This leads very directly to conclusion that the ratio of the sum of the masses of a pair of binary stars to that of the sun is the ratio of the cube of their distance of separation (measured in units of the earth-sun distance) to the square of their period (measured in units of the earth's period). This is the basis for getting the masses of double stars and even of galaxies. The rotation period of a spiral nebula, for example, has been measured as a few hundred million years by observation of the Doppler shift of different portions. The masses of the galaxies, calculated in this manner are  $10^9$  to  $10^{11}$  the mass of the sun. There are other types of calculation which give values more nearly  $10^{13}$  times the mass of the sun.

Mr. Page in the past 5 years has been checking the differential radial velocities of pairs of galaxies and has shown that they are not zero in general. Thus far he has studied 20 pairs, but hopes to extend the observations to 40 pairs or more. The mean mass resulting thus far is  $80 \times 10^9$  times the sun's mass—one-third of them being  $4.5 \times 10^9$  and another third being over  $200 \times 10^9$ . (*Secretary's abstract.*)

## 1360TH MEETING

The 1360th meeting was held in the auditorium of the Cosmos Club, March 28, President McNISH presiding.

Program: HERMAN YAGODA, National Institutes of Health: *The mesons of cosmic-ray physics.*—These particles were first predicted by Yukawa, a Japanese physicist, as being necessary for the conservation of energy and momentum in calculations he was making. He predicted an unstable particle with a mass of 140 times the electron mass and a half-life of the order of half a microsecond, with an electron and a neutrino as the decomposition products. Independently Anderson and Neddermayer found by direct experiment particles of both positive and negative charges intermediate in mass between that of the electron and proton (hence the name meson—intermediate particle).

The new technique of measuring ionizing tracks in photographic emulsions has expanded very greatly the observation of mesons. It now appears that there are mesons of several different masses. Some of those mentioned had masses about 270, 960, 1200 (Pi-mesons or pions) and 2300 (Mu-mesons) electron-masses. Their life times are very short.

An informal communication was presented by A. T. McPherson who spoke on behalf of the Washington Academy of Sciences on the encouragement of science in the high schools. He pointed out that in 1944 13 per cent of the local high-school students were enrolled in science courses, but in 1952 this figure had dropped to only 6 per cent. Other employment has attracted many of the best physics teachers and there is a real dearth of encouragement to the students. The Academy is establishing a register of working scientists who will give advice, counseling, and talks to secondary school students and teachers. He offered the opportunity to enlist in this effort to members of the society. (*Secretary's abstract.*)

## 1361ST MEETING

The 1361st meeting of the Society was the occasion of the twenty-first Joseph Henry Lecture and was held in the auditorium of the Cosmos Club, April 18, 1952, President McNISH presiding.

Program: SYDNEY CHAPMAN, Oxford University: *Meteors and meteorites* (published in this JOURNAL 42: 273-282. 1952).

## 1362D MEETING

The 1362d meeting was held in the auditorium of the Cosmos Club, April 25, 1952, President McNISH presiding.

Program: A. I. MAHAN, Naval Ordnance Laboratory: *Some of the geometrical, physical, and physiological properties of light.*—Mr. Mahan, Vice-President of the Society, presented a demonstration lecture on some properties of light. After a few introductory remarks on the wave theory of light, the small portion of the electromagnetic spectrum that is visible was singled out as the realm of the talk. The sensitivity curve of the eye was shown against a color background of the visible spectrum. Experiments on the continuous spectrum of a tungsten lamp and the line spectrum of a high-pressure mercury arc were demonstrated, using color filters and a transmission diffraction grating, singly and in combination. A striking illustration was offered by the illumination of various colored papers by these two light sources. Polarization by reflection was also demonstrated.

Some physiological phenomena were illustrated by the negative after-image effect yielding complementary color changes and the positive after-images obtained by looking into a photo-flash. This last experiment allowed the audience to watch a sequence of fascinating color changes for some minutes.

Lens aberrations were discussed in terms of patterns yielded by confining illumination pencils to various aperture zones. After photographs of the effects were shown, the phenomena were demonstrated.

The principle of Schlieren images was discussed and demonstrated with the aid of an electric soldering iron. Slides of such images obtained in wind tunnel studies were shown. (*Secretary's abstract.*)

## 1363D MEETING

The 1363d meeting was held in the auditorium of the Cosmos Club, May 9, 1952, President McNISH presiding.

Program: THOMAS H. JOHNSON, Atomic Energy Commission: *The place and future of organized research in modern society.*—The speaker regarded Federal support of fundamental research as in a somewhat precarious position, because of a lack of appreciation and understanding on the part of the general public. The people, unlike the scientists, are not clearly aware of the benefits of such research. Congress, in its appropriations, must reflect the desires of the average person. Support is not easily obtained in years when there is need for an expenditure of 100 billion dollars and heavy taxes yield only half that amount. The Federal Government has not been a source of support of fundamental research in the days before World War II, unlike other national governments.

Against this background the Bush Report in 1945 and the Steelman Report a few years later outlined patterns which finally culminated in the National Science Foundation in 1950. The appropriations for the Foundation have been so small as to place severe limits on its effectiveness and there has been substantial support of fundamental research by the Atomic Energy Commission, in those fields where it could be justified, and by the Office of Naval Research. The former Agency is devoting about 12 million dollars to basic research out of a total of 800 million dollars allocated to research and development.

It seemed to the speaker unwise at the present time to entrust the whole major responsibility for basic research to the National Science Foundation, an agency financially dependent on the general public's appreciation of the importance of basic research. Constant efforts should be made by scientists to increase this appreciation and to make clear the reasons why basic science requires support not accorded equally to art, literature, and music, for example. (*Secretary's abstract.*)

## 1364TH MEETING

The 1364th meeting was held in the auditorium of the Cosmos Club, May 23, 1952, President McNISH presiding.

Program: FRANKLIN V. TAYLOR, Naval Research Laboratory: *Research on man-machine systems.*—Typical problems arose in World War II in connection with gunsight operation. It was

found that operator errors were partly due to the fact that the equipment was not designed to fit the man. For example, some dials were inaccessible when the operator was in a position to read the indicators; both clockwise and counterclockwise dial rotations were used to increase a variable, etc.

Psychologists were asked to help redesign equipment so that ordinary men could operate it. This led to the concept of "anthropomechanical" or "man-machine" systems, where the hardware is one component and the operator the other component of an over-all system. Designing of such systems is called "engineering psychology" or "human engineering."

The engineer's picture of the over-all system as a servomechanism or as an information-handling channel naturally lead to a demand that the psychologists measure the "human transfer function" so that the engineers could treat the operator as a "black box". One of the basic problems is that man's "black box" is definitely nonlinear in operation, in fact it is intermittent as a follow-up device. (This intermittency was brought out in an earlier address before this Society by K. S. Cole.)

The concept of compatibility between control and display was discussed and some experiments relating the effect of compatibility on reaction time and error were described. It has been found that compatibility (similarity, in the cases shown) is so important that a good control paired with a bad display gives worse results than a control which is normally poor, but is compatible with the given display. The same results were found with the roles of control and display interchanged.

A practical example of applied engineering psychology was presented. A man operating a tracking device that has a time lag preceding the display has a tendency to develop violently oscillating corrections. It requires considerable training to achieve even passable operation. A corrective network between the control and display, via an additional mixer or comparison circuit, so that there is no lag in the operator's knowledge of what his control is doing, stabilizes the over-all system. The lag between the actual operation and the display is still present.

In conclusion, the speaker offered the hope that a long term result of this marriage of psychology and engineering will be a better understanding of man's behavior. (*Secretary's abstract.*)

L. A. Wood, *Recording Secretary.*



## Officers of the Washington Academy of Sciences

*President*.....WALTER RAMBERG, National Bureau of Standards  
*President-elect*.....F. M. SETZLER, U. S. National Museum  
*Secretary*.....F. M. DEFANDORF, National Bureau of Standards  
*Treasurer*.....HOWARD S. RAPPLEYE, U. S. Coast and Geodetic Survey  
*Archivist*.....JOHN A. STEVENSON, Plant Industry Station  
*Custodian and Subscription Manager of Publications*  
 HARALD A. REHDER, U. S. National Museum

### *Vice-presidents Representing the Affiliated Societies:*

Philosophical Society of Washington.....A. G. McNISH  
 Anthropological Society of Washington.....WALDO R. WEDEL  
 Biological Society of Washington.....HUGH T. O'NEILL  
 Chemical Society of Washington.....JOHN K. TAYLOR  
 Entomological Society of Washington.....FREDERICK W. POOS  
 National Geographic Society.....ALEXANDER WETMORE  
 Geological Society of Washington.....A. NELSON SAYRE  
 Medical Society of the District of Columbia.....FRED O. COE  
 Columbia Historical Society.....GILBERT GROSVENOR  
 Botanical Society of Washington.....LEE M. HUTCHINS  
 Washington Section, Society of American Foresters.....WILLIAM A. DAYTON  
 Washington Society of Engineers.....CLIFFORD A. BETTS  
 Washington Section, American Institute of Electrical Engineers.....A. H. SCOTT  
 Washington Section, American Society of Mechanical Engineers.....RICHARD S. DILL  
 Helminthological Society of Washington.....L. A. SPINDLER  
 Washington Branch, Society of American Bacteriologists.....ANGUS M. GRIFFIN  
 Washington Post, Society of American Military Engineers.....FLOYD W. HOUGH  
 Washington Section, Institute of Radio Engineers.....HERBERT G. DORSEY  
 District of Columbia Section, American Society of Civil Engineers  
 MARTIN A. MASON

District of Columbia Section, Society for Experimental Biology and Medicine  
 N. R. ELLIS

### *Elected Members of the Board of Managers:*

To January 1953.....C. F. W. MUESEBECK, A. T. MCPHERSON  
 To January 1954.....SARA E. BRANHAM, MILTON HARRIS  
 To January 1955.....ROGER G. BATES, W. W. DIEHL

*Board of Managers*.....All the above officers plus the Senior Editor

*Board of Editors and Associate Editors*.....[See front cover]

*Executive Committee*....WALTER RAMBERG (chairman), F. M. SETZLER, H. S. RAPPLEYE,  
 WILLIAM A. DAYTON, F. M. DEFANDORF

*Committee on Membership*...E. H. WALKER (chairman), M. S. ANDERSON, CLARENCE COT-  
 TAM, R. C. DUNCAN, JOHN FABER, G. T. FAUST, I. B. HANSEN, FRANK KRACEK, D. B.  
 JONES, E. G. REINHARD, REECE I. SAILER, LEO A. SHINN, F. A. SMITH, HEINZ SPECHT,  
 H. M. TRENT, ALFRED WEISSLER

*Committee on Meetings*....H. W. WELLS (chairman), Wm. R. CAMPBELL, W. R. CHAP-  
 LINE, D. J. DAVIS, H. G. DORSEY, O. W. TORRESON

*Committee on Monographs* (W. N. FENTON, chairman):

To January 1953.....R. W. IMLAY, P. W. OMAN  
 To January 1954.....S. F. BLAKE, F. C. KRACEK  
 To January 1955.....W. N. FENTON, ALAN STONE

*Committee on Awards for Scientific Achievement* (J. R. SWALLEN, general chairman):

*For Biological Sciences*.....J. R. SWALLEN (chairman), L. M. HUTCHINS,  
 MARGARET PITTMAN, F. W. POOS, L. P. SCHULTZ

*For Engineering Sciences*.....R. C. DUNCAN (chairman), A. C. FELDNER,  
 WAYNE C. HALL, J. W. MCBURNEY, O. S. READING, H. L. WHITEMORE

*For Physical Sciences*.....L. A. WOOD (chairman), P. H. ABELSON,  
 F. S. DAFT, GEORGE W. IRVING, JR., J. H. McMILLEN

*For Teaching of Science*.....M. A. MASON (chairman), F. E. FOX, M. H. MARTIN

*Committee on Grants-in-aid for Research*.....L. E. YOCUM (chairman), H. N. EATON,  
 K. F. HERZFELD

### *Committee on Policy and Planning:*

To January 1953.....W. A. DAYTON (chairman), N. R. SMITH  
 To January 1954.....H. B. COLLINS, JR., W. W. RUBEY  
 To January 1955.....L. W. PARR, F. B. SILSBEE

*Committee on Encouragement of Science Talent* (A. T. MCPHERSON, chairman):

To January 1953.....A. H. CLARK, F. L. MOHLER  
 To January 1954.....J. M. CALDWELL, W. L. SCHMITT  
 To January 1955.....A. T. MCPHERSON, W. T. READ

*Representative on Council of A. A. A. S.*.....F. M. SETZLER

*Committee of Auditors*.....C. L. GAZIN (chairman), LOUISE M. RUSSELL, D. R. TATE

*Committee of Tellers*...GEORGE P. WALTON (chairman), GEORGE H. COONS, C. L. GARNER

## CONTENTS

	Page
BIOCHEMISTRY.—A bioassay of some stereoisomeric constituents of allethrin. W. A. GERSDORFF AND NORMAN MITLIN . . . . .	313
PALEONTOLOGY.—New species of <i>Lecanocrinus</i> . HARRELL L. STRIMPLE . . . . .	318
BOTANY.—A New species of <i>Sphaceloma</i> on magnolia. ANNA E. JENKINS AND JULIAN H. MILLER . . . . .	323
ENTOMOLOGY.—A new larvaevorid fly parasitic on tortoise beetles in South America (Diptera). CURTIS W. SABROSKY . . . . .	325
ENTOMOLOGY.—An arrangement of the Prepodesmidae, a family of African millipeds. RALPH V. CHAMBERLIN . . . . .	327
PROCEEDINGS: PHILOSOPHICAL SOCIETY . . . . .	333

506. 73  
.D2 W23

VOL. 42

NOVEMBER 1952

No. 11

# JOURNAL

OF THE

# WASHINGTON ACADEMY OF SCIENCES

## BOARD OF EDITORS

WILLIAM F. FOSHAG  
U.S. NATIONAL MUSEUM

J. P. E. MORRISON  
U.S. NATIONAL MUSEUM

JOHN C. EWERS  
U.S. NATIONAL MUSEUM

## ASSOCIATE EDITORS

F. A. CHACE, JR.  
BIOLOGY

J. I. HOFFMAN  
CHEMISTRY

T. P. THAYER  
GEOLOGY

MIRIAM L. BOMHARD  
BOTANY

R. K. COOK  
PHYSICS AND MATHEMATICS

PHILIP DRUCKER  
ANTHROPOLOGY

C. W. SABROSKY  
ENTOMOLOGY

PUBLISHED MONTHLY  
BY THE  
WASHINGTON ACADEMY OF SCIENCES  
MOUNT ROYAL & GUILFORD AVES.  
BALTIMORE, MARYLAND

Entered as second class matter under the Act of August 24, 1912, at Baltimore, Md.  
Acceptance for mailing at a special rate of postage provided for in the Act of February 28, 1925.  
Authorized February 17, 1949



## Journal of the Washington Academy of Sciences

This JOURNAL, the official organ of the Washington Academy of Sciences, publishes: (1) Short original papers, written or communicated by members of the Academy; (2) proceedings and programs of meetings of the Academy and affiliated societies; (3) notes of events connected with the scientific life of Washington. The JOURNAL is issued monthly. Volumes correspond to calendar years.

*Manuscripts* may be sent to any member of the Board of Editors. It is urgently requested that contributors consult the latest numbers of the JOURNAL and conform their manuscripts to the usage found there as regards arrangement of title, subheads, synonymies, footnotes, tables, bibliography, legends for illustrations, and other matter. Manuscripts should be typewritten, double-spaced, on good paper. Footnotes should be numbered serially in pencil and submitted on a separate sheet. The editors do not assume responsibility for the ideas expressed by the author, nor can they undertake to correct other than obvious minor errors.

*Illustrations* in excess of the equivalent (in cost) of one full-page halftone are to be paid for by the author.

*Proof.*—In order to facilitate prompt publication one proof will generally be sent to authors in or near Washington. It is urged that manuscript be submitted in final form; the editors will exercise due care in seeing that copy is followed.

*Unusual cost* of foreign, mathematical, and tabular material, as well as alterations made in the proof by the author, may be charged to the author.

*Author's Reprints.*—Reprints will be furnished in accordance with the following schedule of prices (approximate):

Copies	4 pp.	8 pp.	12 pp.	16 pp.	20 pp.	Covers
100	\$3.25	\$6.50	\$ 9.75	\$13.00	\$16.25	\$3.00
200	6.50	13.00	19.50	26.00	32.50	6.00
300	9.75	19.50	29.25	39.00	48.75	9.00
400	13.00	26.00	39.00	52.00	65.00	12.00

*Subscriptions* or requests for the purchase of back numbers or volumes of the JOURNAL or the PROCEEDINGS should be sent to HARALD A. REHDER, Custodian and Subscription Manager of Publications, U. S. National Museum, Washington 25, D. C.

*Subscription Rates* for the JOURNAL.—Per year..... \$7.50

Price of back numbers and volumes:	Per Vol.	Per Number
Vol. 1 to vol. 10, incl.—not available*	—	—
Vol. 11 to vol. 15, incl. (21 numbers per vol.)	\$10.00	\$0.70
Vol. 16 to vol. 22, incl. (21 numbers per vol.)	8.00	0.60
Vol. 23 to current vol. (12 numbers per vol.)	7.50	0.90

\* Limited number of complete sets of the JOURNAL (vol. 1 to vol. 41, incl.) available for sale to libraries at \$348.50.

MONOGRAPH No. 1, "The Parasitic Cuckoos of Africa," by Herbert Friedmann.	\$4.50
PROCEEDINGS, vols. 1-13 (1899-1911) complete.	\$25.00
Single volumes, unbound.	2.00
Single numbers.	.25

*Missing Numbers* will be replaced without charge provided that claim is made to the Treasurer within 30 days after date of following issue.

*Remittances* should be made payable to "Washington Academy of Sciences" and addressed to the Treasurer, H. S. RAPPLEYE, 6712 Fourth Street, N.W., Washington 12, D.C.

*Exchanges.*—The Academy does not exchange its publications for those of other societies.

# JOURNAL OF THE WASHINGTON ACADEMY OF SCIENCES

VOLUME 42

November 1952

No. 11

ETHNOLOGY.—*Animal names, anatomical terms, and some ethnozoology of the Flathead Indians.* GEORGE F. WEISEL,<sup>1</sup> Montana State University, Missoula, Mont. (Communicated by John C. Ewers.)

A number of dictionaries and word lists have been made of the Flathead tongue, but no effort in the nature of an ethnozoological list has been undertaken. Not being naturalists, those who have studied the Flathead and allied Salishan tribes were unable to obtain accurate European and scientific equivalents for the Indian names of animals. Also, many of the lesser known animals were overlooked.

The most complete inventories of the Flathead language are *Grammatica linguae Selicæ* by P. Mengarini, S. J. (1861), and *A dictionary of Kalispel or Flat-Head language* compiled by J. Giorda, S. J. (1877-79). Both of these contain only the names of the more obvious animals, and they do not use modern linguistic description. There exist a number of short lists of Flathead terms gathered by early traders. Examples of these may be found in *The journals and letters of Major John Owen* (1927, pp. 319-325) and in *The journals of Alexander Henry and of David Thompson* (1897, pp. 714-718). The frontiersmen made no attempts at phonetic spelling, and, as they were primarily interested in trade, the animals listed were restricted to the fur bearers and the larger game species. There is some linguistic material in standard phonetic transcription in a paper by Turney-High (1937, pp. 150-160), but it is very limited and the animal terms are ill defined.

<sup>1</sup> I wish to express my gratitude to Carling I. Malouf who first interested me in pursuing this study, and who rendered invaluable aid throughout its preparation. I am indebted also to Dr. Philip L. Wright for his help on mammal identification and to Dr. Royal B. Brunson for aid with the invertebrates. Expenses were defrayed by a grant from the Research Committee, Montana State University, Missoula, Mont.

By far the most exact work on the Flathead language was done by Hans Vogt. In his monograph *The Kalispel language* (1940, p. 7) he asserted that the Kalispel tongue is almost identical with the Flathead. However, his dictionary does not include many of the animal names listed in this paper, and some of his terms are identified merely as "kind of bird" or "a fish." Other terms are not given their precise English name. For instance, his "red-headed wood-pecker" is more exactly the western pileated woodpecker. Most of Hans Vogt's names coincide rather well with those taken from my informants. Some discrepancies may be due to differences in Flathead and Kalispel dialects.

The homeland of the Flathead tribe proper, at least in historic times, was just west of the Continental Divide in the Bitterroot Valley of Montana (Teit, 1930, p. 310; Turney-High, 1937, p. 12). The fauna in this area has remained less changed since the advent of white men than most. Big-game species, such as elk, deer, bear, and mountain goat, are hunted there today. Undoubtedly, if the accounts of early travelers through this country are to be acknowledged, most of the mammals have been depleted greatly, especially bighorn sheep and grizzly bear (Koch, 1941, pp. 357-369). The Flathead relied on these animals and on wild plants for their needs. There is no evidence that they had domesticated plants. They were a nomadic people, well supplied with horses, who supplemented their local sustenance with buffalo, which they hunted regularly on the plains east of the mountains (Rep. Comm. Ind. Affairs, 1857, pp. 663-669; Ewers, 1948, p. 14). These factors

make the Flathead admirably suited for ethnozoological study. As the original fauna is qualitatively intact, the informants do not have to rely on hearsay for the recognition of animals; and, as they once depended on hunting and fishing for food, they are keenly aware of the animals around them.

Several Flathead Indians were questioned on aspects of ethnozoology, but it was soon evident that they cast aside veracity in their efforts either to please or to "pull the leg" of the interrogator. The chief informant finally selected was Ellen Big Sam, a woman of 71 years at closest estimate. She is exceptionally bright, has always been a close observer and lover of animals, and is sincere in her answers. She was born in the Bitterroot Valley and married into the tribe. Although she has some Shoshonean ancestry, she is said to speak as pure Flathead as anyone on the Flathead Reservation. Since she does not speak English, her adopted son, Joe Big Sam Woodcock, acted as interpreter. He is an intelligent man who served several years with the army in the South Pacific. According to Joe, Ellen knows the Indian names of more animals than any other Flathead. He claims that members of his own generation are acquainted with but few of them and that his young boy learns to speak Flathead reluctantly. Evidently, the older Indians—the few who can recall the days when most of their living came from the hunt—are the only ones who know most of the terms. This generation has practically died out. Acculturation has proceeded so rapidly that in another five to ten years the information will no longer be available.

To associate the Indian names as accurately as possible with the various animals, the principal informant was taken to the Zoology Museum of the University of Montana where mounted or pickled specimens were laid before her. A previous attempt at using colored pictures proved a failure. Ellen is not conditioned to visualizing from a flat perspective. In some instances, when she could not recall the name of a bird or a fish, she was allowed to take the specimen for further consideration to Mrs. Jerome Vanderberg, another older woman encamped near the University gathering bitterroots. Ellen possesses an

amazing knowledge of the local fauna and is undoubtedly accurate in her identifications. If she does not recognize an animal, or has forgotten its name, she admits it. To test her acumen, she was shown an eastern brook trout and a rainbow trout. Neither of these fish is native to the upper Columbia watershed, but they closely resemble the bull trout and the cut-throat trout, respectively, which are indigenous. She immediately spotted these two species as ones introduced into the country by white men.

For anatomical terms, a dissected cat and an articulated human skeleton were used. Although it was realized that older Indians had dressed out many mammals, it was still a surprise to find how well the viscera are known and the detail in which they are classified. For example, the greater omentum is not lumped in one word with the other mesenteries but is given a separate name.

The means of hunting and the role different animals played in the subsistence of the Flathead have been fairly well covered by Teit (1930, pp. 341-349) and Turney-High (1937, pp. 111-129). No particular effort was made to gather more information on the subject. However, a number of miscellaneous and out-of-the-ordinary observations were collected.

The simplified form of phonetic symbols from *Phonetic transcription of Indian languages* (Smithsonian Misc. Coll., 1916) is used in this study. Admittedly, my limitations in the highly specialized training needed for Indian orthography do not impart the precision desired. However, it is believed that the words can be easily recognized and that they should be of use to ethnologists and linguists who wish more accurate animal identifications than were previously provided.

#### FISHES

The fish fauna of western Montana has been greatly altered in the past 50 years. Accounts by men who were in the territory in 1850-65 reveal that trout were amazingly abundant in the Clark Fork and Bitterroot Rivers (Dodson, 1852, original MS.; Stewart, 1925, p. 186; McAdow, 1952, p. 45). But today it takes an expert fisherman and modern equipment to make much of a catch in these rivers. Pollution, irrigation, and overfish-

ing have taken their toll. Except for the introduction of rainbow trout (*Salmo gairdnerii*), brown trout (*Salmo trutta*), and brook trout (*Salvelinus fontinalis*), the species that inhabit the rivers and creeks must be the same as ages ago. In the lakes many more exotic species have been added. These include lake trout (*Salvelinus namaycush*), Great Lakes whitefish (*Coregonus clupeaformis*), black bullhead (*Ameiurus melas*), yellow perch (*Perca flavescens*), largemouth bass (*Micropterus salmoides*), and pumpkinseed (*Lepomis gibbosus*).

Although fish were extensively used for food by the Flathead, fishing contributed much less to their livelihood than hunting. There were no large runs of fish in their streams that could be relied on to furnish ample provender at certain times of the year. Their related tribes—the Pend d'Oreille, Kalispel, and Spokane—were much more dependent on fisheries.

The Flathead were well acquainted with the salmon, although it is not native to the waters of western Montana. There is a legend that Coyote attempted to bring them this fish, but, when part way up the west side of Lolo Pass, he became tired and dropped it, and it flopped back down the Idaho side of the divide. Lolo Pass, made famous in the journey of Lewis and Clark, bears the Indian name of tumsumcli (no salmon). However, the Flathead used to go south to the Snake and Salmon Rivers in Idaho for the salmon runs, often fishing in cooperation with Shoshones, Banacks, or Nez Percé. Women and children, as well as men, took part in catching the fish with weirs, traps, hooks, spears, and even clubs. Salmon usually were dried on racks and then packed in parfeches lined with wild mint.

Of the indigenous fish, dolly varden and cutthroat trout were favored most for food. Rattlesnake Creek, which flows into the Clark Fork River at Missoula, is called n'se'ai' for the dolly varden found there. These trout were caught with a baited hook and a line of woven horsehair, or snagged with bone hooks. Ellen Big Sam demonstrated how the bone hooks were manufactured from the scapula of deer. This thin, flat bone, when fresh, was fractured easily and the slivers fashioned into a barbed point, which was then fastened with sinews to a straight piece of bone or to a small stick.

Suckers and large minnows were utilized also. Fishing for them took place at any time of the year. Squawfish and chub, both large minnows,

were among the commonest and most easily caught. Like suckers, they were fried until crisp, as they are very bony. One means of cooking them in the past was to clean them and run a pointed willow into the mouth and posteriorly through the flesh of the back by the tail. Two or three fish could be skewered on a single stick and roasted over a fire. Fish that were caught locally were seldom preserved by drying or pounded into pemmican.

Two species of fish, the American grayling (*Thymallus signifer*) and the burbot (*Lota lota*), common in the upper Missouri River but not found in the Bitterroot, were shown to the principal informant. She had never seen or heard of them. When the Flathead were in the Missouri River country, they were intent on hunting and avoiding their enemies and undoubtedly did little if any fishing.

Eastern brook trout, yellow perch, largemouth black bass, and pumpkinseed were recognized by the Indians as transplanted and are known by the inclusive term simpiqit'tqu, translated as "thrown in."

With a few minor omissions, the fish shown to the informant represent all kinds that are to be found in the drainage of the Bitterroot, Flathead, and Clark Fork Rivers—the streams that flow through the homeland of the Flathead Indians. They included introduced as well as native species. As with the other lists of vertebrate animals, the fish are grouped in Table 1 according to their systematic arrangement rather than alphabetically. The scientific and common English names are those approved by the Committee on Common and Scientific Names of Fishes (Trans. Amer. Fish. Soc., 1945, pp. 355-384).

#### AMPHIBIANS AND REPTILES

There are relatively few species of amphibians in the Rocky Mountain area, and what there are, are not numerous. Only on rare occasions, when starvation was imminent, were they used for food. The different species of frogs were not recognized, but they were distinguished from the toads. As the English translation of the Flathead name for tadpoles is "young frog," the Indians must have realized that tadpoles metamorphosed into the adult form and were not another kind of animal. In many respects the Indians were farther advanced in their knowledge of zoology than Europeans of two centuries ago.

The only reptile eaten was the turtle, which

was roasted in pits. Turtle eggs also were considered a delicacy. The reptiles listed below (Table 2) are common throughout the area, except the rattlesnake, which is more or less restricted to the upper part of the Bitterroot Valley.

BIRDS

The Flathead ate all the birds and their eggs, but, with the flesh of large mammals as plentiful as it was, birds were not seriously hunted. In particular, Franklin's grouse was taken fairly often, mostly because this "fool hen" can be procured simply by hitting it with a stick. Boys and squaws would sometimes set snares for sharp-tailed grouse; and snow buntings and waxwings, which come into the country in large flocks early in winter, were shot and trapped for food. Magpie eggs were probably taken more

frequently than eggs of any other bird. The magpie's large nests are constructed in low trees and brush, and so they are conspicuous and easily accessible. Some effort was made to obtain eagles and large hawks for wing bones, from which medicine flutes were made, and for feathers. Ellen confirmed Turney-High's statement (1937, p. 113) on the method of capturing eagles. The hunter dug a camouflaged pit and placed a bait of guts on the edge of it. When an eagle lighted on the bait, it was grabbed with the hands. An eagle hunter always took several sweat baths before hiding in the pit, making it less likely that his body odor would betray his presence. Pileated woodpeckers were sought for an unusual purpose. The bill of this bird was considered to be efficacious for relieving toothache. It was ground to a powder and packed in tooth cavities.

TABLE 1.—FLATHEAD INDIAN NAMES OF FISHES

Scientific classification	English name	Flathead name	Remarks
Pisces.....	Fish in general	sawé'ús	
<i>Oncorhynchus nerka</i> .....	Red salmon	súmslí	
<i>Salmo clarkii</i> .....	Cut-throat trout	esk'aik'áísúe	The term refers to the "black" color their backs have in water when viewed from above.
<i>Salvelinus malma</i> .....	Dolly varden:		
	small	se'ai'	
	large	ai'	
<i>Salvelinus fontinalis</i> .....	Eastern brook trout	sinpúqit'tq' <sup>n</sup>	Called "thrown in" because they are planted.
<i>Prosopium williamsoni</i> .....	Mountain white fish	xoyu	Translated "puckered lips."
<i>Catostomus catostomus</i> .....	Longnose sucker	é'el'ne	
<i>Catostomus macrocheilus</i> .....	Columbia largescaled sucker	k'óqúe	
<i>Ptychocheilus oregonense</i> .....	Columbia squawfish	ci't'laus	
<i>Mylocheilus caurinum</i> .....	Columbia River chub		
<i>Rhinichthys cataractae</i> .....	Longnose dace	clú'wé	The term is used for small fish in general.
<i>Richardsonius balteatus</i> .....	Redside shiner		
<i>Ameiurus melas</i> .....	Black bullhead	úpúpútsí	The name "whiskers" refers to the barbels.
<i>Perca flavescens</i> .....	Yellow perch		
<i>Micropterus salmoides</i> .....	Largemouth black bass	sinpúqit'tq' <sup>n</sup>	See brook trout above.
<i>Lepomis gibbosus</i> .....	Pumpkinseed		
<i>Cottus cognatus</i> .....	Slimy muddler	s'tit'ma	

TABLE 2.—FLATHEAD INDIAN NAMES OF AMPHIBIANS AND REPTILES

Scientific classification	English name	Flathead name	English equivalent
Amphibia:			
<i>Rana pipiens</i> .....	Leopard frog	slumslame	
<i>Rana pretiosa</i> .....	Spotted frog	sIxúlt'slumslame	Young frog
Frog larva.....	Tadpole	senaq'eq'a	
<i>Bufo boreas</i> .....	Toad	silsilé	
<i>Ambystoma macrodactylum</i> .....	Long-toed salamander		
Reptilia:			
Ophidia.....	Snakes	slečéwile'	
<i>Thamnophis elegans</i> .....	Gartersnake	q'ái'slečéwile'	Black snake
<i>Thamnophis ordinatus</i> .....			
<i>Pituophis catenifer</i> .....	Gopher snake	sólé'nú	
<i>Crotalis viridis</i> .....	Rattlesnake	k'lai'ólex' <sup>u</sup>	
<i>Chrysemys picta</i> .....	Painted turtle	spel'q'a	



TABLE 3.—FLATHEAD INDIAN NAMES OF BIRDS

Scientific classification	English name	Flathead name	Remarks
<i>Gavia immer</i> .....	Loon	ʉsolus	
<i>Aechmophorus occidentalis</i> .....	Western grebe	st'eʉuksin	
<i>Ardea herodias</i> .....	Great blue heron	semalq <sup>u</sup> e	So named because its throat is rounded like a hill.
<i>Botaurus lentiginosus</i> .....	American bittern	x'awitō <sup>ʉ</sup>	
<i>Cygnus columbianus</i> .....	Whistling swan	s'pak'amī	The term is referable to "something white."
Anatidae (in part).....	Geese in general	k <sup>u</sup> 'esix'ō	
<i>Chen hyperborea</i> .....	Snow goose	wa'ō	Named for the sound they make.
<i>Branta canadensis</i> .....	Canada goose	t <sup>e</sup> 'petap <sup>a</sup>	The informant was not sure this was the goose to which the term applied.
<i>Branta sp.</i> .....	Domestic white goose	spa'k'amī	See swan above.
Anatidae (in part).....	Ducks in general	sestlexum	The informant was unable to differentiate the mallard, baldpate, green-winged teal, pintail, or shoveller.
<i>Mergus merganser</i> .....	American merganser	sxaxai	
<i>Cathartes aura</i> .....	Turkey vulture		Not recognized.
<i>Meleagris gallopavo</i> .....	Domestic turkey	n'slet'slata	
Accipiteridae.....	Hawks in general	stelstelstamu	The term means, "it grabs."
	Small hawks	s'kakanō	
<i>Astur atricapillus</i> .....	Goshawk	s'k'ak'ai	
<i>Buteo borealis</i> .....	Red-tailed hawk		This is one of the commonest hawks in the area, but it was not recognized.
<i>Aquila chrysaetos</i> .....	Golden eagle	mlekanu	
	Old dark golden eagle	skaifimī	
<i>Haliaeetus leucocephalus</i> .....	Bald eagle	p <sup>u</sup> 'kaltkai	The name means "white head."
<i>Circus hudsonius</i> .....	Marsh hawk	k'ak'alstse	
<i>Pandion haliaetus</i> .....	Osprey	stex'ux'u	
<i>Falco peregrinus</i> .....	Duck hawk	xa'tot	
<i>Falco sparverius</i> .....	Sparrow hawk	e'lea	
<i>Dendragapus obscurus</i> .....	Blue grouse	ka	
<i>Bonasa umbellus</i> .....	Ruffed grouse	sq <sup>u</sup> 'isq <sup>u</sup> 'is	Term also used for domestic chickens.
<i>Pedioecetes phasianellus</i> .....	Sharp-tailed grouse	s'k'a	
<i>Phasianus colchicus</i> .....	Ring-necked pheasant	ēusue'sq <sup>u</sup> 'isq <sup>u</sup> 'is	Translated as "Chinamen's chicken."
<i>Fulica americana</i> .....	American coot	l'i'dle	Name derived from the noise they make.
<i>Numenius americanus</i> .....	Long-billed curlew	wat'tluwit	The cry of the curlew sounds like its Indian name.
<i>Oryzechus vociferus</i> .....	Killdeer	stēeun	
<i>Totanus melanoleucus</i> .....	Greater yellowlegs	nosxina	The name, "long nose" refers to this bird's long beak.
<i>Larus californicus</i> .....	California gull		
<i>Zenaidura macroura</i> .....	Mourning dove	xemi's'xem	The name is from the cooing sound the dove makes.
<i>Bubo virginianus</i> .....	Great horned owl	s'nīne	
<i>Nyctea nyctea</i> .....	Snowy owl	n'nspsinme	
<i>Speotyto cunicularia</i> .....	Burrowing owl	n'ēēuwa	
<i>Chordeilus minor</i> .....	Nighthawk	s'spas	When the nighthawk dives through the air, its wing feathers make a vibratory noise. The term is derived from this sound.
<i>Stellula calliope</i> .....	Calliope hummingbird	l'ōwatni	
<i>Megasceryle alcyon</i> .....	Belted kingfisher	tsalts	
<i>Colaptes cafer</i> .....	Red-shafted flicker	q'elqe	Term is referable to "red wings."
<i>Ceophloeus pileatus</i> .....	Pileated woodpecker	spuwalqen	Term alludes to the beak and means "pick."
<i>Asyndesmus lewis</i> .....	Lewis's woodpecker	tsiutsū	
<i>Dryobates pubescens</i> .....	Downy woodpecker	ctelxū	
<i>Tyrannus verticalis</i> .....	Arkansas kingbird	elēēēa	
<i>Riparia riparia</i> .....	Bank swallow	} clemo	The swallows are named "mud" for the material from which they construct their nests.
<i>Hirundo erythrogaster</i> .....	Barn swallow		
<i>Cyanocitta stelleri</i> .....	Steller's jay	q <sup>u</sup> 'asq <sup>u</sup> 'i	Term is derived from the dark color of the bird. The bluejay dancers are so named because they paint themselves dark. Evidently there is no connection between the medicine dance and the bird.
<i>Pica pica</i> .....	American magpie	aun	
<i>Corvus corax</i> .....	Raven	m'la	

TABLE 3.—(Cont.)

Scientific classification	English name	Flathead name	Remarks
<i>Corvus brachyrhynchos</i> .....	Crow	sca'a'	
<i>Nucifraga columbiana</i> .....	Clark's nutcracker	snalsqu	
<i>Penthestes gambeli</i> .....	Mountain chickadee	ctuskane	
<i>Cinclus mexicanus</i> .....	Dipper	k'axumēne	
<i>Turdus migratorius</i> .....	Robin	sk'lēxaxē	
<i>Sialia currucoides</i> .....	Mountain bluebird	n'sq'ilq'a'a	The term means "it's blue."
<i>Regulus satrapa</i> .....	Golden-crowned kinglet		Recognized, but no name recalled.
<i>Bombycilla cedrorum</i> .....	Cedar waxwing	kakusum	The waxwing's name means "star," perhaps for the yellow spot near the wing tip.
<i>Vireo olivaceus</i> .....	Red-eyed vireo	elqakutleaq <sup>o</sup>	Same term used for other vireos, tanagers, and small yellow birds in general.
<i>Passer domesticus</i> .....	English sparrow	sūap'slue'wū	Translated as "white man's bird."
<i>Sturnella neglecta</i> .....	Western meadowlark	w'e'o'wī'	
<i>Agelaius phoeniceus</i> .....	Red-winged blackbird	elkaiekiskla	Translated as "pinto blackbird."
<i>Icterus bullocki</i> .....	Bullock's oriole	wē'ō'xō	
<i>Piraga ludoviciana</i> .....	Western tanager	elqakutleaq <sup>o</sup>	See Vireo above.
<i>Hedymeles melanocephalus</i> .....	Black-headed grosbeak	}n'q'ita'nak's	The Indian name means "big nose," alluding to the large beak.
<i>Hesperiphona vespertina</i> .....	Evening grosbeak		
<i>Pinicola enucleator</i> .....	Pine grosbeak		
<i>Loxia curvirostra</i> .....	Red crossbill	clai'ai'xosa	Translated "crossed nose."
<i>Junco oreganus</i> .....	Oregon junco		Common, but not recognized.
<i>Melospiza melodia</i> .....	Song sparrow	s'xlasasi	Term derived from the sound of its song.
<i>Plectrophenax nivalis</i> .....	Snow bunting	xslum'men'kum'kut	Name translated as "little snows."

According to the Indians, ducks, sharp-tailed grouse, and bitterns are much less numerous now than formerly. Also, they realize that the California gull, English sparrow, and Chinese pheasants are newcomers.

A checklist of the birds of western Montana compiled by the U. S. Forest Service (no date), contains 256 different species and subspecies. A great many of these are infrequent visitors to the state. Also, groups of them—especially the sparrows, warblers, and shorebirds—include numerous species that are difficult for even the avid birdwatcher to tell apart. Rather than include the whole list in this study, 70 of the most common and distinguishable birds were selected and exhibited to the informant. Their arrangement and nomenclature (Table 3) are adopted from the A.O.U. *Check-List of North American birds* (1931).

#### WILD MAMMALS

By far the greatest part of the Flathead's subsistence came from hunting large mammals. Although the narrow valleys in their own country had but few buffalo, there was an abundance of sheep, goat, elk, and deer which could support them. However, with the advent of the horse, it became more feasible to hunt the great herds of buffalo which grazed the plains on the other side of the Divide. In their seasonal quest for bison, the Flathead went at least as far east as the

Lower Musselshell and Big Horn, and as far south as Fort Hall. (For further information on this subject and the methods used on the hunt, see Teit, 1930, pp. 344-348; Turney-High, 1937, pp. 112-123; and Ewers, 1948, p. 14.)

Smaller mammals had important, though often overlooked, values. For instance, the weasel was trapped in the winter for its white fur and tail, which were much esteemed for trimmings on dress. It is still one of the most popular adornments on Flathead fancy clothes. Porcupine quills also were favored for decoration on clothing. Only the longest and most even quills were chosen; the sharp ends were cut off; and then they were boiled. Before the introduction of commercial dyes, quills were frequently colored by adding yellow lichen (*Evernia barbata*) to the water. After boiling, the softened quills were flattened by drawing them through the fingers. They were sewn in a zigzag fashion, held fast at each angle with sinews. Usually, two needles were used in sewing. It was a more arduous process than decorating with beads.

Small mammals were also a source of food. Rabbits were caught in snares for this purpose by children, and ground squirrels and marmots were hunted frequently. The last two, when baked or barbecued, were considered excellent eating. In preparation, the hair was first burnt off; next, they were gutted; and then the legs, which were

cut off close to the body, were sewn inside the coelomic cavity. Badgers were eaten sometimes, but the more numerous red squirrels seem to have received little attention.

In his checklist of the recent mammals of Montana, Wright (1951, pp. 47-50) includes 137 species and subspecies; 73 of these are thought to occur west of the Continental Divide. Most of the genera in the list have a number of species and subspecies which are so much alike that only a qualified mammalogist can separate them. As examples, there are 10 different chipmunks (genus *Tamias*) and 9 different pocket gophers (genus *Thomomys*). A test with a series of various chipmunk species showed that the Indians did not differentiate the mammals by obscure distinctions like cranial characters or coat color, such as used by systematists. Consequently, only 50 kinds of mammals were selected for identification—one chipmunk, one pocket gopher, etc.—but they are believed to be representative of all the mammals in Flathead country (Table 4).

#### DOMESTIC MAMMALS

The Flathead had comparatively large herds of horses, which were notably superior in stamina and quickness to most Indian cayuses. Traders came from the Emigrant Road in the 1850's to barter for these fine animals. One, Van Etten, came all the way from Salt Lake City to procure horses for the Pony Express, an organization that required the best. The Blackfeet, as well as white traders, coveted these horses and made frequent raids to steal them. A Blackfoot brave told Governor Stevens that he "stole the first Flathead horse he came across—it was sure to be a good one" (Rep. Explor. etc., 1855, vol. 1, p. 148; Woody, 1896, p. 97; Hamilton, 1900, p. 48; Stuart, 1925, vol. 1, p. 169). The Flathead used to castrate their horses before the coming of white men, even with flint knives; and they knew that if gelded after maturity the horse would retain more of the vigor of the stallion.

Some of the first herds of cattle in Montana were possessed by Flathead. They procured most of them from men who traded for worn-out stock along the Oregon Trail late in the 1840's and who wintered the animals in the relative safety of Flathead country. This animal husbandry was encouraged by the Jesuit missionaries at St. Marys in the Bitterroot Valley, and later at St. Ignatius, Flathead Valley (Rep. Explor. etc., 1855, vol. 1, p. 323; Stuart, 1925, vol. 2, p. 97;

Owen, 1927, numerous short references). It is evident from Table 5 that terms referring to cattle are derived from those used for buffalo.

The place of the dog in Flathead culture has been dealt with by Turney-High (1937, pp. 104-105). Ellen agreed that they did not use dogs for food as so many of the plains tribes did.

#### VERTEBRATE ANATOMY

Because they frequently dressed and prepared game, Flathead are naturally thoroughly familiar with vertebrate anatomy. They utilized practically all the carcass. Of the viscera, only the gall and urinary bladders were not eaten. Of course, sweetbreads, kidney, and liver were used; but besides, fat in the mesenteries was extracted for use in cooking; fat deposited around the kidney was considered a special dainty; brains served for food but were saved mostly for softening hides; and not only were the stomach and intestines devoured, but their contents were also. When the animal was reduced to a skeleton, the bones were not wasted, but were cracked to yield marrow (stos), and were mashed and boiled to make a broth. The greasy part of the broth which was skimmed off is called stčelamosł.

Ellen related an interesting use of one of the bones. Flathead sharpers manufactured stick game bones from the humerus of man. They believed that if the human humerus were used, it would numb the hand of the opponent, and betray which held the bone. Should the opponent suspicion such treachery, he could wash his hands in water containing the petals of wild roses, which allowed him to handle the bone with impunity.

Some terms given in Table 6—such as thumb, wrist, and arm—are used also to designate the bones in that portion of the body. Rather than repeat them, they are listed only with the skeletal terms.

#### INVERTEBRATES

Unlike some tribes in arid regions to the south, the Flathead do not seem to have considered any of the invertebrates as food. The reason is clear. None of the invertebrates occurred in great abundance in western Montana, and the more edible plants and game animals were generally plentiful enough for their needs. This lack of reliance on invertebrates as a food source is reflected in the relatively poor acquaintance, compared with the vertebrates, that the Flathead have with insects, worms, and molluscs.

TABLE 4.—FLATHEAD INDIAN NAMES OF MAMMALS

Scientific classification	English name	Flathead name	Remarks
<i>Sorex cinereus</i>	Long-tailed shrew		This small nocturnal animal was not recognized.
<i>Myotis lucifugus</i>	Little brown bat	t'elt'elue	
<i>Ursus americanus</i>	Black bear	unslamk'ai	
<i>Ursus horribilis</i>	Grizzly bear	sũmk'ai	
<i>Martes pennanti</i>	Fisher		This mammal is scarce in the area. It was not recognized.
<i>Martes americana</i>	Marten	tlõ'lo	
<i>Mustela frenata</i>	Long-tailed weasel:		
	white peltage	x'la'pa	
	dark peltage	cl'el	
<i>Mustela vison</i>	Mink	sca'xale	
<i>Gulo luscus</i>	Wolverine		Rare this far south. Not recognized.
<i>Mephitis mephitis</i>	Striped skunk	x'a'ste <sup>u</sup>	
<i>Taxidea taxus</i>	Badger	s'xoi'xõ	
<i>Lutra canadensis</i>	Otter	ltkũ	
<i>Vulpes fulva</i>	Red fox	wa'wa'a	
<i>Canis latrans</i>	Coyote	sinçelê	
<i>Canis lupus</i>	Timber wolf	n'tsiutsen	
<i>Felis concolor</i>	Cougar	s'squ'tesumuye	
<i>Lynx canadensis</i>	Canada lynx	senk'asu	
<i>Lynx rufus</i>	Bobcat	senk'asu	
<i>Marmota flaviventris</i>	Golden-mantled marmot	senctesa	
<i>Citellus columbianus</i>	Columbian ground squirrel	s'F-ê	
<i>Citellus lateralis</i>	Golden mantled ground squirrel	sali	
<i>Citellus tridecemlineatus</i>	Thirteen-lined ground squirrel	sali	
<i>Cynomys ludovicianus</i>	Black-tailed prairie dog	cleku	Not present on west side of Divide in Montana.
<i>Tamias amoenus</i>	Western chipmunk	k'uk'scawê	
<i>Tamiasciurus hudsonicus</i>	Red squirrel	isêê	
<i>Glaucomys sabrinus</i>	Flying squirrel	sxo'pope	
<i>Thomomys talpoides</i>	Pocket gopher	põlêe	
<i>Castor canadensis</i>	Beaver	skaleu	
<i>Dipodomys ordii</i>	Kangaroo rat		Not recognized. It occurs only east of the Rockies.
<i>Peromyscus maniculatus</i>	White-footed mouse	q'ueukutene	
<i>Neotoma cinerea</i>	Bush-tailed wood rat	xç'ot	
<i>Microtus pennsylvanicus</i>	Meadow mouse	stumxoini	
<i>Ondatra zibethica</i>	Muskrat	çeeçexco	
<i>Zapus princeps</i>	Jumping mouse		Not recognized.
<i>Mus musculus</i>	House mouse	q'ueukutene	This introduced species is given the same name as the white-footed mouse.
<i>Erethizon dorsatum</i>	Porcupine	sq'el'a	
<i>Ochotona princeps</i>	Rocky Mountain pika	s'çine	
<i>Lepus americanus</i>	Snowshoe rabbit	cl'q'a	
<i>Lepus townsendii</i>	Jack rabbit	cl'q'a	
<i>Sylvilagus nuttallii</i>	Cottontail	wiusele'açen	
<i>Cervus canadensis</i>	Wapiti:		
	general term	tsetêa	
	cow	sene	
	bull	tseçsene	
<i>Odocoileus virginianus</i>	White-tailed deer:		
	doe	sta'õ	
	buck	swatle	
<i>Odocoileus hemionus</i>	Rocky Mountain mule deer:		
	doe	stoltse	
	buck	põwe	
	fawn	spalpĩ	
	fawn in fall	sleq'kũelt'	
<i>Alces americana</i>	American moose	saselkes	The same term is used for domestic mules.

TABLE 4.—(Cont.)

Scientific Classification	English name	Flathead Name	Remarks
<i>Rangifer montanus</i> .....	Mountain caribou	stiele'st <sup>o</sup>	Caribou did not range as far south as Flathead country, but the neighboring Kalispel undoubtedly hunted them.
<i>Antilocapra americana</i> .....	American pronghorn	ste'an	Occasional pronghorns were possibly found on the west side of the Continental Divide.
<i>Bison bison</i> .....	American bison: general term	q <sup>u</sup> oilq <sup>u</sup> ai	Translated as 'black mass.'
	bull	q <sup>u</sup> oilq <sup>u</sup> aistolslem	
	cow	q <sup>u</sup> oilq <sup>u</sup> aiste'ma	
	calf	q <sup>u</sup> oilq <sup>u</sup> aitselq <sup>u</sup> elq <sup>u</sup> ele	
	yearling	slq <sup>u</sup> oik <sup>u</sup> k <sup>o</sup>	
<i>Ovis canadensis</i> .....	Bighorn	cla'omene	
<i>Oreamnos americanus</i> .....	Mountain goat	cl <sup>o</sup> 'tle	

TABLE 5.—FLATHEAD INDIAN NAMES OF DOMESTIC MAMMALS

English name	Flathead Name	English name	Flathead name
Dog:		Colors of horses:	
general term.....	q <sup>u</sup> asami	apaloosa.....	čela'elxū
male.....	sk'altamixuq <sup>u</sup> asami	bay.....	q <sup>u</sup> el
bitch.....	clamōq <sup>u</sup> asami	black.....	q <sup>u</sup> ai
pup.....	s'slitit <sup>o</sup>	brown.....	čelče'e
Horse:		buckskin.....	čelpu
general term.....	sinčelsaska	gray.....	čaxai
stallion.....	n'melmelq <sup>u</sup> e	palamino.....	čepi
gelding.....	sk'altamxoska	pinto.....	k'ai'e
mare.....	samō	smoky.....	čelpa
filly.....	s'lamōskl'akai'i	Cow.....	ste'ma
colt.....	sk'altamixuk'akai'i	Bull.....	stolslem
yearling.....	cl'kekōme	Calf.....	tselq <sup>u</sup> elq <sup>u</sup> ele
race horse.....	sinskoikōsinsčelsaska		

Only the commonly occurring invertebrates were displayed for the informant. In the list below (Table 7), the arthropods are classified just to order, as this is about the level of recognition that the Indians have for them. It is true that the Flathead identify more insects than this list indicates, but they designate most of them merely by affixing the color of the animal, or large or small, to its general term—like red ant, black ant, and so on. The table is arranged according to the alphabetical sequence of the English names.

LITERATURE CITED

AMERICAN ORNITHOLOGISTS' UNION. *Check-list of North American birds*, ed. 4. 1931.  
 ANNUAL REPORTS, COMMISSIONER OF INDIAN AFFAIRS. Washington, D. C., 1857.  
 COMMITTEE ON COMMON AND SCIENTIFIC NAMES OF FISHES. *A list of common and scientific names of the better known fishes of the United States and Canada*. Trans. Amer. Fish. Soc. 75: 355-384. 1945.  
 DODSON, JOHN F. [Original MS. diary in collec-

tions of Montana State Historical Society, Helena, 1852.]  
 EWERS, JOHN C. *Gustavus Sohon's portraits of Flathead and Pend d'Oreille Indians, 1854*. Smithsonian Misc. Coll. 110(7): 1-68. 1948.  
 GIORDA, J. *A dictionary of the Kalispel or Flat-Head Indian language, compiled by the missionaries of the Society of Jesus*, 2 vols. St. Ignatius, Mont., 1877-79.  
 HAMILTON, WILLIAM T. *A trading expedition among the Indians in 1858, from Fort Walla Walla to the Blackfoot country and return*. Contr. Hist. Soc. Mont. 3: 33-123. 1900.  
 HENRY, ALEXANDER, and THOMPSON, DAVID. *The journals of Alexander Henry and of David Thompson. New light on the early history of the greater Northwest*, 3 vols. Edited by Elliott Coues. New York, 1897.  
 KOCH, ELLERS. *Big game in Montana from early historical records*. Journ. Wildlife Management 5(4): 357-370. 1941.  
 MCAADOW, PERRY W. *Perry W. McAdow and Montana in 1861-1862*. Edited by Ross Toole. Montana Mag. Hist. 2(1): 41-53. 1952.  
 MENGARINI, GREGORY. *Grammatica linguae Selicæ*. New York, 1861.  
 OWEN, JOHN. *The journals and letters of Major*

- John Owen, 1850-1871*, 2 vols. Edited by Seymour Dunbar and Paul C. Phillips. New York, 1927.
- REPORT OF COMMITTEE OF AMERICAN ANTHROPOLOGICAL ASSOCIATION. *Phonetic transcription of Indian languages*. Smithsonian Misc. Coll. 66(6): 1-15. 1916.
- REPORT OF EXPLORATIONS AND SURVEYS TO ASCERTAIN THE MOST PRACTICABLE AND ECONOMIC ROUTE FOR A RAILROAD FROM THE MISSISSIPPI RIVER TO THE PACIFIC OCEAN . . . 1853-55. Ex. Doc. No. 78, vol. 1 of 12 vols. Washington, D. C., 1855.
- STUART, GRANVILLE. *Forty years on the frontier*, 2 vols. Edited by Paul C. Phillips. Cleveland, 1925
- TEIT, JAMES A. *The Salishan tribes of the western plateaus*. Edited by Franz Boas. 45th Ann. Rep. Bur. Amer. Ethnol.: 23-395. 1930.
- TURNER-HIGH, HARRY H. *The Flathead Indians of Montana*. Mem. Amer. Anthropol. Assoc. 48: 1-161. 1937.
- U. S. FOREST SERVICE, REGIONAL OFFICE, MISSOULA, MONT. *List of the birds of Western Montana*. Field Notes on Wildlife, Northern Rocky Mountain Region. Missoula, no date.
- VOGT, HANS. *The Kalispel language*. I Kommissjon Hos Jacob Dybwad, Oslo, Norway, 1940.
- WOODY, F. H. *A sketch of the early history of Western Montana*. Contr. Hist. Soc. Montana 2: 88-106. 1896.
- WRIGHT, PHILIP L. *Check list of the recent mammals of Montana*. Proc. Montana Acad. Sci. 10: 47-50. 1951.

TABLE 6.—FLATHEAD INDIAN ANATOMICAL TERMS

English term	Flathead term	English term	Flathead term
External anatomy:		Skull	spelkainiépa
Back of any animal	senč'emétes	Tail (caudal vertebrae)	susps
Beak of bird or nose of mammal	sunpesa	Thigh (femur)	stóóč'in?
Calloses	senolxawéčensen	Toes (phalanges)	stóóč'in
Chest of any animal	s-č'áwawáčéč	Vertebrae	axsáp-m
Claws of bird or mammal	k'ólk'ai	neural spine	c-líčen
Ear of mammal or operculum of fish	tene	Wrist (carpals)	sq'alč'umšene
Elbow	s-č'umwósaxum	Internal anatomy:	
Eye	s-č'úq'elú	Afterbirth (placenta)	senumxumxwél
Feather	skapu	Anus	senpóčen
Fins of fish:		Blood	senxule
anal	tu'óc	Blood vessel	k'ak'áxum
dorsal	sinélečen	Brain	sapenk'ai-n
paired	tó'tis	Caecum	salenč
Hair	spum	Diaphragm	estwep
Head	sp'elki-n	Gall bladder	q'alín
Hide	k'ett	Greater omentum	sétq'úe
Hip and thigh region	stumst-e	Heart	spu'ús
Knee	sčumkai'sene	Intestine, large	spalekai
Leg	sčémakasčes	Intestine, small	stxenč
Mandible of mammal or lower beak of bird	g'úlep'	Kidney	m-tas
Pads on feet of dog, etc.	steecs	fat surrounding kidney	ólíxos!
Scales of fish	čéméčes	Liver	pe'ninč
Shoulder	senčumk'ai	Lungs	spe'upuxa
Tail of fish, bird, or mammal	susps	Mesentery, other than omentum	sčosu
Teats	sk'ai'em	Nostril	senla
Toes	čtesčis	Pancreas	xelip'?
Wing	čúwaxunsk'a'pu	Rectum	spóóú
Skeletal system:		Soul	senčéméčensxus
Ankle (tarsals)	sg'elčumsíčen	Spleen	xelip'
Arm (including humerus, radius, ulna)	sčawaxun	Stomach	o-lín
Breast bone (sternum)	sk'epemín	abomasum of ruminant	sk'ai'etle
Collar bone (clavicle)	ntclek'ai	rumen of ruminant	c-xaip'
Finger (phalanges):		Teeth	x'alewxo
in general	saq'amen	sharp teeth as canines	wíxexn'alewxo
little finger	sta'ótekai	bridle teeth of elk	senk'axumi
middle finger	saq'amenesl'nq'ú <sup>5</sup>	Tendon	tinč
ring finger	stáótkaislnq'ú <sup>5</sup>	Throat or esophagus	sk'almlten
thumb	sčulčst	Tongue	fixucé
Heel (tarsals)	sčmelčen	Trachea	c'speelk'altlet'
Knee cap (patella)	čenkaiččen	Urinary bladder	sentéčíta
Pelvis (innominate)	t-kalame	Urine	té'e
Ribs	skóx'tip	Uterus	senswó'sewxelten
Shank (tibia and fibula)	sčémakečen	Vulva	t-čéi
Skeleton	sps'estso		

TABLE 7.—FLATHEAD INDIAN NAMES OF INVERTEBRATES

Scientific classification	English name	Flathead name	Remarks
PLATYHELMINTHES:			
Sp.....	Tapeworm	senxa'seme	Translated as "breeding inside."
MOLLUSCA:			
<i>Margaritana margaritifera</i> .....	Clam	skōq <sup>u</sup> ilane	Procured by trade from coast Indians and used to decorate the dress. Translated as "sucking on something."
Sp.....	Cowry	ta'miō	
<i>Helisoma trivolvis</i> .....	Snail	} ta'miō	
<i>Lymnea stagnalis</i> .....	Snail		
ANNELIDA:			
Sp.....	Earthworm	ēttequqanē	The term means "bait." It is used for fish-bait other than earthworms.
<i>Placobdella parasitica</i> .....	Leech	ta'miō	Identical word used for snail.
ARTHROPODA:			
Hymenoptera.....	Ant	sxwōwi	Word used for small clicking beetles (family Elateridae).
Hymenoptera.....	Bee	skol'wi	
Coleoptera.....	Beetle	ta'so'oc	
	Larva of wood beetle	slwi'telq <sup>u</sup> a	
Lepidoptera.....	Butterfly	k <sup>u</sup> el'lōdlex <sup>o</sup>	The aquatic larvae of the caddis-fly construct portable cases of sand or vegetable debris. The Indian name translated as "bound on the outside" refers to this case.
	Caterpillar	ēhilaq <sup>u</sup> ate	
Trichoptera.....	Caddis-fly larva	te'tāncānpi	
Decapoda.....	Crayfish		Not recognized.
Orthoptera.....	Cricket	salsl	The word is used for insects with two pairs of large flight wings.
Odonata.....	Dragonfly	x'awatekaine	
Diptera.....	Fly	xelmalten	As the maggot has the same name as the fly, it was evidently realized that the larvae metamorphosed into flies.
	white maggot	xelmalten	
	black maggot in meat	tētēslu	
Orthoptera.....	Grasshopper	ttace	
	Hive of wasps	skolslex <sup>u</sup>	
Lepidoptera.....	Moth.....	ēq <sup>u</sup> eq <sup>u</sup> e'ene	
Diptera.....	Mosquito	se'lakus	
Araneida.....	Spider	sōe'it	
	large spider	two'pn'	
Plecoptera.....	Stonefly	sta'kanēen	
Hemiptera.....	Water strider	stetōōme	
Acarina.....	Wood tick	ēstēlēen	Translated as "horns lying down," and has its origin from a legend in which the tick loses a set of horns it once had.

PALEONTOLOGY.—*The type species of the gastropod genus Protostylus.* ROGER L. BATTEN, Geology Department, Columbia University. (Communicated by G. A. Cooper.)

In preparing the classification of Paleozoic gastropods for the *Treatise on invertebrate paleontology*, it was noticed that the type for the genus *Protostylus* has not been fixed. The genus was proposed by H. Mansuy in 1914<sup>1</sup>

with two described species *P. lantenoisi* and *P. dussaulti*. The better illustrated and described species is *P. lantenoisi*, and it is hereby designated as the genotype species.

<sup>1</sup> Mansuy, H., *Nouvelle contribution à la paléontologie du Yunnan*: 1. Mémoires du Service Géolo-

gique de L'Indochine, pp. 11–12, pl. 1, figs. 17 a, b, 18 a, b, 1914.

PALEONTOLOGY.—*Morphology of the test in the foraminiferal genus Tristix Macfadyen.* ALFRED R. LOEBLICH, JR., and HELEN TAPPAN, U. S. National Museum.

During the course of many years' work on the Mesozoic Foraminifera in America, the writers have encountered numerous specimens of the genus *Tristix* Macfadyen. In almost every occurrence, both in America and elsewhere, the species of this genus are accompanied by specimens like the form described as *Quadratina* by ten Dam (1946, p. 65). Although in the past the writers have differentiated these two morphological types, *Tristix* being triangular in section and *Quadratina* quadrate in cross section, the evidence now seems to indicate definitely that they are congeneric, and the name *Quadratina* ten Dam should be suppressed as a junior synonym of *Tristix* Macfadyen.

*Duplication of species.*—In any large series of *Tristix*, selected from a single sample there are invariably a few quadrate forms that can be associated with the typical specimens by a similarity in all other characters. Macfadyen (1941, p. 55) in describing the genus *Tristix* also noted that some "species" were quadrangular in section instead of triangular, and stated that these "may possibly be found to be congeneric." A study of the occurrence of described species of *Quadratina* shows that almost invariably they are associated with very closely similar species of *Tristix*, and probably one or the other of the specific names should be placed in synonymy. An example of this is shown by four Jurassic species described by the writers (1950, p. 52) from the western interior of the United States and here shown in Figs. 1-4. These specimens were originally referred to *Tristix alcima* Loeblich and Tappan (Fig. 1) and *Quadratina inornata* Loeblich and Tappan (Fig. 2), but they are similar in being comparatively large, robust and with rounded angles, and large circular apertures. The latter name is here placed in synonymy. Another pair of "species" from the same beds were *Tristix reesidei* Loeblich and Tappan (Fig. 3) and *Quadratina juncta* Loeblich and Tappan (Fig. 4), the "types" of both similarly being smaller than the preceding form, more sharply angled and with more deeply excavated sides. The

last name here is also placed in synonymy. An example from the Lower Cretaceous is described later in this paper, under *Tristix quadrata* (Vieaux).

There are numerous other instances that could be cited from the American Lower Cretaceous, but a complete list of synonymies will be given by the writers in their forthcoming monograph; hence is not discussed here. A similar duplication of species can be shown for most other occurrences of *Quadratina*, as they seem always to be associated with triangular forms of close affinity.

*Evidence from "freaks."*—It has been often observed that occasional "monstrous" specimens may be of value in determining relationships of foraminiferal genera. Examples are specimens of *Gaudryina*, with an occasional terminal chamber showing a tendency toward *Gaudryinella* (Tappan, 1943, p. 489), and *Citharinella*, which develops a third angle, showing a relationship with *Tribrachia* (Loeblich and Tappan, 1941, p. 19). We have also in our Lower Cretaceous collections specimens of *Citharina* with an occasional equitant chamber showing a development toward *Fronicularia*, a *Lenticulina* that develops a long series of globular uniserial chambers like *Nodosaria*, *Flabellamina* developing into *Frankeina*, *Gumbelina* developing into *Rectogumbelina*, *Textularia* with a central terminal chamber or two suggesting a relationship with *Bigenarina* and many similar examples.

In the large quantity of Lower Cretaceous material examined by the writers there have been found a few such monstrosities which show some bearing on the relationships of the forms now under discussion. A specimen from the Glen Rose formation (Fig. 7) is a typical *Tristix* in its early stages, but at about the midpoint of its development it became suddenly quadrate, so that it is a *Tristix* for half of its life span and a "*Quadratina*" in its later life history. A record of a similar occurrence of a "mixed" form is found in Berthelin (1880, p. 47). He recorded *Rhabdognium acutangulum* Reuss from the French Albian, stating:



My specimens have chambers a little less serrated than the type, and tend to approach *R. maertensi* Reuss; but do not have a quadrangular section.

The triangular shells are in general somewhat more numerous than the quadrangular; but the character is not an absolutely constant one. I possess a specimen of an upper Jurassic species, which shows an abrupt passage without any transition from one to the other form. (Free translation.)

From this description Berthelin apparently had a specimen similar to the "mixed" form of Fig. 7. Obviously a single specimen cannot change its generic identity midway in its growth, and these freaks thus show a definite relationship between these "genera." Another freak in our Lower Cretaceous collection (although not here illustrated) is a *Lingulina* in its early stage, and becomes triangular in the later development. These two examples would seem to definitely indicate that *Lingulina*, *Tristix* and "*Quadratina*" should at least be placed in the same family, with *Lingulina* probably ancestral to *Tristix*.

A specimen that shows an even more interesting development is shown in Fig. 8. This is a twinned specimen which developed chambers simultaneously in opposite directions from the proloculus, one series of chambers being triangular in section (Fig. 8c) and the opposite extremity being quadrate in section (Fig. 8b). This specimen shows no transition from one genus to another but apparently it belonged to the two "genera" simultaneously and therefore supplies additional evidence that *Tristix* and *Quadratina* are synonymous, the number of angles being variable as are the number of ribs in a *Nodosaria*, etc.

*Character of the aperture.*—The aperture of *Tristix* presents several problems. It varies from a simple rounded one to triradiate or radiate. The genotype species of *Tristix*, *Rhabdogonium liasinum* Berthelin, has a circular aperture. Our Jurassic species also have only simple apertures (Loeblich and Tappan, 1950 a, b) as do the majority of the Lower Cretaceous species (Tappan, 1940, 1943). An occasional species which has deeply excavated sides may show a triradiate aperture, as does *Tristix excavata* (Reuss) as shown by van Voorthuysen (1947), and as can be seen on certain of our Lower Cretaceous specimens. This reaches a climax

in such forms as *Triplasia temirica* Dain, 1934, which has a radiate aperture. It is possible that forms with definite radiate apertures should be excluded from this genus, but because of the fact that numerous genera of the Lagenidae may have either rounded or radiate apertures and as no specimens of this Russian Jurassic species have been available to the writers for examination, the radiate aperture is not here considered sufficiently important to warrant separation of this species.

"*Quadratina*" shows a similar variation in apertural characters. The genotype species, *Quadratina depressula* ten Dam, was described as having a radiate aperture. Other described species have simple rounded apertures. These quadrate forms are always less frequent than the triangular ones, however, hence as great a variation is not to be expected, because of the more limited number of available specimens.

Van Voorthuysen (1947, p. 44) figured a short internal tube in *Tristix excavata* Reuss from the Albian of Holland, but these could only be observed in young specimens with delicate and hollow tests. The writers have not been able to demonstrate an internal tube in the abundant specimens from the Comanchean strata (Albian) of Texas, but this may in part be due to the type of preservation and more probably, these short delicate internal tubes may have been resorbed by the organism.

*Relationship of Tristix and Dentalinopsis.*—In general *Tristix* is strongly triangular in section and *Dentalinopsis* Reuss is rounded in cross section, with three faint longitudinal keels. However, some species of *Tristix* closely approach the generic characters of *Dentalinopsis* and they seem to be closely related. This is especially true of some of the quadrate species such as *Dentalinopsis subquadrata* Tappan, 1940, which has very poorly developed angles and *Quadratina euthemon* Loeblich and Tappan which is nearly circular in section, with four faint longitudinal keels. It is possible that these species should be placed in *Dentalinopsis*, because of the lack of angularity and if so, this genus also would vary from triangular to quadrangular, presenting another character in common with *Tristix* and *Dental-*

*inopsis* and suggesting some relationship between them.

It is interesting to note, however, that these two genera are placed in separate families by various authors. Cushman (1948, p. 261) places *Dentalinopsis* in the family Buliminidae and derives it from the series *Angulogerina-Trifarina-Dentalinopsis* by acceleration of the uniserial stage, and *Tristix* was placed in the Lagenidae. Galloway (1933, p. 372) places *Dentalinopsis* in the family Uvigerinidae and also derives it from *Trifarina* by acceleration of the uniserial stage. Galloway notes that *Dentalinopsis* may have had some other ancestry as such uniserial forms are produced in many lines of evolution and also noted that *Dentalinopsis* occurs much earlier in the geologic column than does *Trifarina*, which was not mentioned by Cushman. Van Voorthuysen (1947, p. 45) also derives *Dentalinopsis* from *Trifarina* and has the line *Tristix-Entosolenia* [= *Oolina*] derived from an offshoot of the line *Trifarina-Dentalinopsis*. The derivation of *Oolina* (*Entosolenia* of van Voorthuysen) from *Tristix* is untenable in the writers' opinion, as we strongly doubt that unilocular forms are invariably the evolutionary end members, derived from multilocular ancestors, although this has been often stated in the

literature. *Oolina* occurs as low stratigraphically as the Albian in Texas and the Upper Lias of Switzerland and if earlier records of *Lagena* were critically examined it may be found that some true *Oolina* occurred in earlier strata.

The presence of the internal tube in *Tristix* has led to its being placed by van Voorthuysen in the family Buliminidae, but it seems more difficult to see why *Dentalinopsis*, which appears so closely related to the Lagenidae, and incidentally to *Tristix*, is placed in the Buliminidae, for no internal tube has been demonstrated in *Dentalinopsis*. At the present time, the writers are uncertain as to what value in classification should be placed on these internal tubes. Parr (1947, p. 128) has included *Oolina* (*Entosolenia*), *Fissurina*, and *Parafissurina* in the family Lagenidae although all possess clearly defined internal tubes. Some other lagenids, such as *Lingulina falcata* Heron-Allen and Earland, possess internal tubes. *Glandulina glans* d'Orbigny of the Polymorphinidae has been demonstrated to possess an internal tube by Selli (1947, pl. 3) and *G. laevigata* d'Orbigny also has been shown to have this identical structure by van Voorthuysen (1950, p. 37). These tubes have been observed by the present writers in *Glandulina* from as far back as the Eocene.

FIGS. 1a-2b.—*Tristix alcima* Loeblich and Tappan: 1a, Side view of triangular holotype (USNM 105007); 1b, top view, showing subacute angles and rounded aperture; 2a, side view of quadrate form (USNM 105013) originally described and named as *Quadratina inornata* Loeblich and Tappan; 2b, top view, showing quadrate section, subacute angles, and rounded aperture. All  $\times 95$  and both specimens from the Redwater shale member of the Sundance formation (Oxfordian) of South Dakota.

FIGS. 3a-4b.—*Tristix reesidei* Loeblich and Tappan: 3a, Side view of holotype (USNM 105009) showing arched sutures, acute angles, and pointed base; 3b, top view, showing triangular section, acute angles, and rounded aperture  $\times 95$ ; 4a, side view of quadrate form (USNM 105017) showing pointed base and moderately excavated sides (this form was originally described as *Quadratina juncta* Loeblich and Tappan); 4b, top view, showing quadrate section and rounded aperture. All  $\times 158$  and both specimens from the Redwater shale member of the Sundance formation (Oxfordian) of South Dakota.

FIGS. 5a-7b.—*Tristix comalensis* Loeblich and Tappan, n.sp.: 5a, Side view of holotype (USNM P. 842) showing arched sutures, triangular form with little excavation of the sides; 5b, top view showing triangular form with rounded angles and rounded aperture; 6, side view of paratype (USNM P. 843a) showing more slender form than that of the holotype; 7a, side view of paratype (USNM P. 843b) showing form with early *Tristix*-stage and later stages developing a quadrate section ("*Quadratina*" stage) thus producing a "mixed" form; 7b, top view showing quadrate outline of late chambers of the "mixed" form. All  $\times 150$  and all from the Glen Rose formation, Trinity group, Lower Cretaceous of Comal County, Tex.

FIGS. 8a-9b.—*Tristix quadrata* (Vieaux): 8a, Side view of twinned hypotype (USNM P. 845) with the quadrate half oriented at the top of the figure and the lower half exhibiting the triangular section, both parts arising from the same proloculus; 8b, top view of "*Quadratina*" half showing rounded aperture and slightly excavated sides; 8c, top view of *Tristix* portion of the twin showing elongate aperture (from the Kiamichi formation, Fredericksburg group, Lower Cretaceous, of Tarrant County, Tex.); 9a, side view of typical triangular hypotype (USNM P. 846) showing rounded proloculus and arched sutures; 9b, top view showing rounded aperture and sides with little excavation (from the Kiamichi formation, Fredericksburg group, Lower Cretaceous, of Johnston County, Okla.). All  $\times 150$ .

All illustrations are shaded camera-ludica drawings. Figs. 1-4 by Helen Tappan Loeblich; Figs. 5-9 by Sally D. Lee, scientific illustrator, Smithsonian Institution.

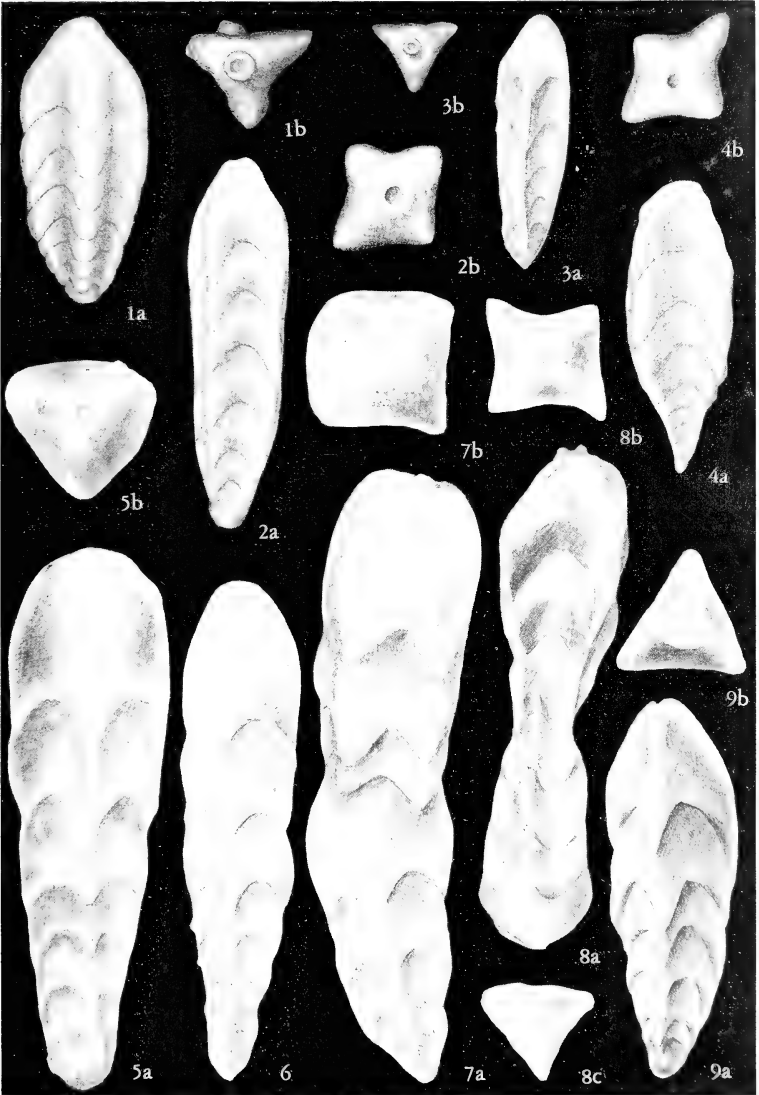

Figs. 1-9. (See opposite page for legend).

Other members of the Polymorphinidae such as *Polymorphina williamsoni* Heron-Allen and Earland, *P. acuta* Roemer and *P. soria* Reuss also have well-defined internal tubes. In addition the writers have in preparation the description of a Recent fauna in which many of the Polymorphinidae have internal tubes. It seems that this character appears in widely divergent families in the Foraminifera and may be considerably more prevalent than is noted in the literature. The writers hesitate to remove from the Polymorphinidae the species that possess internal tubes, until the whole group is studied in detail, and it seems best to consider both *Dentalinopsis* and *Tristix* as members of the family Lagenidae, closely related to each other and to *Lingulina*, and although all three appear early in the history of the family, the last two appear to be somewhat specialized in that at least some of their species possess well-defined internal tubes.

With the above considerations in view concerning the form of the test the writers consider it advisable to suppress the name *Quadratina* as a junior synonym of *Tristix* and to revise the generic description of *Tristix* so as to include quadrate as well as triangular forms.

#### Genus *Tristix* Maefadyen, 1941

*Tristix* Maefadyen, Phil. Trans. Roy. Soc. London, ser. B, biol. sci., no. 576, 231: 54. 1941.

*Tricarinnella* ten Dam and Schijfsma. C. R. Somm. Soc. Geol. France, no. 16: 233. 1945.

*Quadratina* ten Dam, Bull. Soc. Géol. France, ser. 5, 16: 65. 1946.

*Dentalinopsis* Reuss (part, of authors)

*Rhabdogonium* Reuss (part, of authors)

*Triplasia* Reuss (part, of authors)

*Emended diagnosis*.—Test free, uniserial, generally triangular in section, but occasionally quadrate; wall calcareous, hyaline; aperture terminal, rounded to radiate, with an internal tube in at least some species.

*Tristix comalensis* Loeblich and Tappan, n. sp. Figs. 5-7

Test free, narrow elongate, slightly tapering, sides nearly flat, angles broadly rounded; chambers up to 9 in number, increasing gradually in height as added, final chamber of approximately equal height and breadth; usually triangular in

section, and infrequently quadrate; sutures distinct, slightly depressed, gently arched at the center of each face of the test, curving gently downward to the angles of the test; wall calcareous, hyaline, surface unornamented; aperture terminal, rounded.

Length of holotype (Fig. 5), 0.65 mm; greatest breadth, 0.18 mm; length of paratype of Fig. 6, 0.60 mm; breadth, 0.15 mm. Length of paratype of Fig. 7, 0.73 mm. Other specimens range from 0.26 to 0.99 mm in length.

*Remarks*.—This species differs from *T. quadrata* (Vieaux) in being larger and broader with higher chambers and less strongly arched sutures, more rounded angles and less excavated sides.

*Types and occurrence*.—Holotype (USNM P. 842) and paratypes of Figs. 6, 7 (USNM P. 843a-b) and unfigured paratypes (USNM P. 844a-v) all from the Glen Rose formation (Trinity group), Lower Cretaceous, from 520 feet below the top of the formation, in a road cut on the east side of U. S. Highway 281, 2.4 miles north of the junction with Texas Highway 46, in Comal County, Tex.; collected by A. R. Loeblich, Jr., 1949.

#### *Tristix quadrata* (Vieaux)

*Dentalinopsis excavata* (Reuss) Plummer (not *Rhabdogonium excavatum* Reuss, 1862), Univ. Texas Bull. 3101: 187, pl. 9, figs. 11-12. 1931.

*Dentalinopsis excavata* (Reuss) Tappan, Journ. Pal. 14 (2): 118, pl. 18, figs. 10 a-b. 1940.

*Dentalinopsis märtensi* (Reuss) Tappan (not *Rhabdogonium märtensi* Reuss, 1863), Journ. Pal. 14 (2): 119, pl. 18, figs. 11 a-c. 1940; Journ. Pal. 17 (5): p. 509, pl. 81, figs. 23 a-b. 1943.

*Dentalinopsis quadrata* Vieaux, Journ. Pal. 15 (6): 626, pl. 85, figs. 8 a-b. 1941.

*Tristix acutangula* (Reuss) Loeblich and Tappan (not *Rhabdogonium acutangulum* Reuss, 1863), Woodbine Symposium, Southern Methodist Univ., Fondren Sci. Ser. no. 4: 88, pl. 2, figs. 17-18. 1951.

Test free, small, narrow, parallel-sided; consisting of a rectilinear series of about 3 to 9 chambers, increasing gradually in height as added and either triangular or quadrangular in section, with angles fairly sharp and sides moderately excavated; sutures distinct, slightly depressed, strongly arched on the faces, extending sharply downward at the angles; wall calcareous, hyaline; aperture terminal, rounded.

Length from 0.3 to about 0.7 mm, breadth of a face 0.13 to 0.18 mm.

*Remarks.*—This species has been referred to various European species in the past, but the European species are distinct. *Rhabdogonium excavatum* Reuss is a much larger species, with flaring rather than parallel sides and with much more deeply excavated faces. *R. märtensi* Reuss is a quadrangular form with sharper angles and more excavated sides and is much larger (the type being 1.15 mm in length) and more flaring. *R. acutangulum* Reuss differs in being larger, with much lower chambers, which are only very slightly arched centrally.

The only available name proposed for the present species is *Dentalinopsis quadrata* Vieaux. This specific name was proposed for the quadrate forms, but must be applied to the entire species, even though it is actually descriptive of only a small percentage of the specimens, the majority being triangular in section.

The holotype of Vieaux was stated to be in the University of Oklahoma collections, but Vieaux's types have never been received at that institution and are thus not available for comparison. However, the present writers were on the collecting trip with Vieaux when his samples were obtained, and a duplicate set of all samples is in our collection. These samples have supplied many specimens of both the triangular forms, which Vieaux referred in his faunal list to *Dentalinopsis excavata* (Reuss), and the quadrangular forms on which he based his species *D. quadrata*. The specimens referred by Tappan (1943, p. 509) to *D. quadrata* are a distinct species, a much larger form than the present species, and with more excavated sides.

*Types and occurrence.*—Holotype (in Vieaux collection) from the Denton formation of north Texas.

Hypotype of Fig. 8 (USNM P. 845) from the Kiamichi formation, from a 5-foot section of brown marl, 11 feet above the base of the exposure in a deep road cut on the Stove Foundry Road, just north of the new Texas and Pacific Railroad shops, in Fort Worth, Tarrant County, Tex. Collected by A. R. Loeblich, Jr., and Helen Tappan Loeblich, 1941.

Hypotype of Fig. 9 (USNM P. 846) from the Kiamichi formation, from a 4.2-foot section of dark blue-gray clay shale with sandy seams, in a zone of abundant *Gryphea navia* 3 feet above the base of the exposure and 15 feet below the base of the Duck Creek, in a deep roadside ditch on

the south side of the road in the SE $\frac{1}{4}$ , sec. 10, T. 5 S., R. 7 E., 1 mile east of Bee, Johnston County, Okla. Collected by W. E. Ham, of the Oklahoma Geological Survey, and A. R. Loeblich, Jr., 1946.

Other published records figure this species from the Del Rio clay of central Texas, the Grayson and Duck Creek formations of northern Texas and southern Oklahoma, and the Maness formation (subsurface) of east Texas. It thus ranges from the Kiamichi formation (Fredericksburg) through the Maness formation (uppermost Washita).

## REFERENCES

- BERTHELIN, M. *Mémoire sur les foraminifères fossiles de l'étage Albien de Monclay (Doubs)*. Mém. Soc. Géol. France (3) **1** (5): 1-84. 1880.
- CUSHMAN, J. A. *Foraminifera, their classification and economic use*, ed. 4: 1-605. Harvard Univ. Press, 1948.
- TEN DAM, A. *Les espèces du genre de foraminifères Quadratina, genre nouveau de la famille des Lagenidae*. Bull. Soc. Géol. France (5) **16**: 65-69. 1946.
- GALLOWAY, J. J. *A manual of Foraminifera*: 1-483. Bloomington, Ind., 1933.
- LOEBLICH, A. R., JR., and TAPPAN, H. *Some palmitate Lagenidae from the Lower Cretaceous Washita group*. Bull. Amer. Pal. **26**: (99): 1-23. 1941.
- . *North American Jurassic Foraminifera: I. The type Redwater shale (Oxfordian) of South Dakota*. Journ. Pal. **24**: 39-60. 1950a.
- . *North American Jurassic Foraminifera II. Characteristic western interior Cretaceous species*. Journ. Washington Acad. Sci. **40**: 5-19. 1950b.
- MACFADYEN, W. A. *Foraminifera from the Green Ammonite beds, Lower Lias, of Dorset*. Phil. Trans. Roy. Soc. London (B), biol. sci. no. **576**, **231**: 1-73. 1941.
- PARR, W. J. *The lagenid Foraminifera and their relationships*. Proc. Roy. Soc. Victoria **58**: 116-130. 1947.
- SELLI, R. *La struttura della Glandulina glans d'Orbigny e la posizione sistematica del genere*. Riv. Italiana Pal. **52**: 1-20. 1947.
- TAPPAN, H. *Foraminifera from the Grayson formation of northern Texas*. Journ. Pal. **14**: 93-126. 1940.
- . *Foraminifera from the Duck Creek formation of Oklahoma and Texas*. Journ. Pal. **17**: 476-517. 1943.
- VAN VOORTHUYSEN, J. H. *An internal tube in the genus Tristix Macfadyen*, 1941. Geol. Mijnb. no. 3: 44-45. 1947.
- . *The quantitative distribution of the Plio-Pleistocene Foraminifera of a boring at the Hague (Netherlands)*. Med. Geol. Stieh., n.s., no. 4: 31-49. 1950.

## PALEONTOLOGY.—A rare Tertiary glycymerid from South Carolina and Florida.

DAVID NICOL, U. S. National Museum.

F. S. MacNeil, of the U. S. Geological Survey, several months ago showed me some specimens of an unusual glycymerid which had been collected from a water well near Miami, Fla. Recently I examined the specimens more closely and decided that they are not *Glycymeris quinquerugata*, as they had been labeled, but are *Pectunculus transversus* Tuomey and Holmes from Smith's Goose Creek, S. C. Although the description given by Tuomey and Holmes is brief, the salient characters mentioned by them (the great length and the wrinkled posterior side) are significant enough to identify the specimens in the Museum as the same species. Unfortunately, *Pectunculus transversus* Tuomey and Holmes, 1856, is a homonym of *Pectunculus transversus* Lamarck, 1819, and Tuomey and Holmes's species is herein renamed.

*Glycymeris aberrans* Nicol, n. name  
Figs. 1-5

*Pectunculus transversus* Tuomey and Holmes. Pleiocene fossils of South-Carolina: 51, pl. 17, fig. 6c. 1856; not *Pectunculus transversus* Lamarck, Animaux sans vertèbres 6 (pt. 1): 55. 1819.

*Description*.—The following is the original description by Tuomey and Holmes:

Shell ovate transverse, equilateral; anal side on the interior wrinkled; pallial margin finely crenulated.

This specimen, although a cast, is so very characteristic that it cannot be confounded with any other species. The length is nearly twice the breadth, and the teeth are closer on the anal than on the buccal ridge of the hinge.

With the additional material at hand, the following can be added to the original description: Beaks orthogyrate, located at the middle of the dorsal border; ligament small and low, made up of three or four chevrons, amphidetic; dorsal border long and straight, ventral margin broadly arched; teeth located on a broad arch, 20 to 25 in number, the larger ones grooved in the middle; crenulations on interior margin numerous, narrow, closely spaced, eight per cm on the mid-ventral border of a specimen 27 mm in height; central part of shell has broad, slightly raised radial ribs, which disappear at both ends of the shell; no radial striae appear on the broad ribs,

but the absence of striae may be due to poor preservation; radial threads present on the umbo and occasionally on the ends of the shell.

Most striking feature is rugae on outside of shell; rugae large and numerous, commonly reflected on interior margin of shell as small undulations, particularly on posterior and dorsal margins but in some specimens on anterior margin too; rugae best developed on umbo and at both ends of shell, middle of larger shells relatively free of them; rugae not parallel to growth lines and commonly split up by them.

Measurements in mm—

U. S. N. M. no.	Height	Length	Convexity
Hypotype 561486.....	26.8	33.6	19.3
Hypotype 561484.....	16.9	20.9	13.7

*Comparisons*.—The closest related species to *Glycymeris aberrans* is the rugate form of *G. americana* (Defrance). *G. aberrans* differs from it by being more elongate, by having well-developed rugae on both ends of the shell, and by not having well-developed striae on the broad radial ribs.

*Localities*.—This species was reported from Smith's Goose Creek, S. C., by Tuomey and Holmes. The locality is described in greater detail by Cooke (1936, p. 129) as follows:

U. S. Geological Survey Loc. no. 10412. Bluff on southeast side of Goose Creek a third of a mile southeast of Seaboard Air Line Railway and three-fourths of a mile southeast of Melgrove (Berkeley County, South Carolina).

The specimens in the U. S. National Museum are from U. S. Geological Survey loc. no. 15112. From well G.—188, Krome Avenue and Tamiami Trail, 19 miles west of Miami, Dade County, Fla. (67.8 to 144.9 feet below the surface).

*Geologic age*.—Tuomey and Holmes called the Smith's Goose Creek locality Pliocene. Cooke (1936, p. 130) tentatively assigns the beds at Smith's Goose Creek to the Pliocene but says that they may be upper Miocene. Miss Julia Gardner identified the well material at the depths where *Glycymeris aberrans* was found as upper Miocene. The closest relative to *G. aberrans*, the rugate form of *G. americana*, is confined to upper Miocene strata.

*Types and other specimens*.—Hypotype U. S. N. M. no. 561484 and hypotype U. S. N. M. no.

561486 and 13 other specimens in U. S. N. M. Collection with nos. 561483, 561485, 561487, 561488, 561489.

## REFERENCES

COOKE, C. WYTHE. *Geology of the Coastal Plain*

of South Carolina. U. S. Geol. Surv. Bull. 867: 196 pp. 1936.

TUOMEY, M., and HOLMES, F. S. *Pleiocene fossils of South-Carolina: containing descriptions and figures of the Polyptaria, Echinodermata and Mollusca*: 152 pp., 30 pls. Charleston, S. C., 1855-1857.

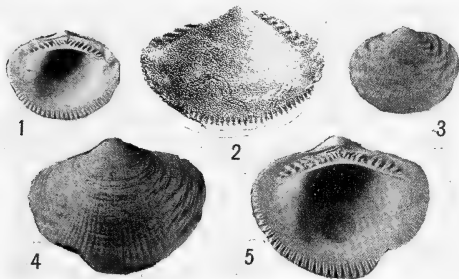

FIGS. 1-5.—*Glycymeris aberrans*: 1, Interior view and 3, exterior view, right valve, hypotype U. S. N. M. no. 561484; 2, internal cast, copied from Tuomey and Holmes, 1856, pl. 17, fig. 6c; 4, exterior view and 5, interior view, right valve, hypotype U. S. N. M. no. 561486. All figures natural size. Hypotypes from U. S. G. S. loc. no. 15112, 19 miles west of Miami, Dade County, Fla. Tuomey and Holmes's specimen from U. S. G. S. loc. no. 10412, Smith's Goose Creek, Berkeley County, S. C.

ENTOMOLOGY.—*Notes on synonymy in Siphonaptera*. G. H. E. HOPKINS, British Museum (Natural History). (Communicated by C. F. W. Muesebeck.)

In the course of preparing a catalogue of the N. C. Rothschild collection of fleas a few instances have come to light in which names currently accepted as referring to the same taxonomic unit actually apply to different units, and many more in which names believed to refer to separate units are synonyms. The volume dealing with the Pulicoidea is now in the press, and it is hoped that it will be published this year, but it seems desirable to put on record some of the other hitherto-unpublished instances in which the accepted placing of a taxonomic unit appears to be incorrect. Unless stated otherwise, all instances in which changes in the placing of species and subspecies are suggested are based on examination of specimens, commonly types or paratypes. With regard to genera, which are subjective units and not objective, there are two courses which can be adopted if two apparently natural groups of species differ by characters apparently of little phylogenetic significance, and the choice between

them seems to be mainly a matter of convenience. Obviously a difference in phylogenetically important characters must be recognized by generic separation, but where this is not the case it seems to me to be better to emphasize the resemblances between the two groups than their differences unless considerations of convenience force one to snatch at any chance of breaking up an unwieldy group. Where, therefore, a small group has been broken up into subgenera on phylogenetically unimportant characters I can see little advantage in retaining this arrangement, whereas if the same thing has happened in a large group convenience dictates accepting it. This is, for instance, the case in the *Rhadinopsyllinae*, where I have grave doubts whether *Rhadinopsylla* and *Rectofrontia* are really generically separable or even whether they are entirely natural groups, but have kept them separate because the group would otherwise be so inconveniently large.

Apart from instances of synonymy at-

tributed below to other workers who have kindly informed me about them, there are many other instances in which a particular synonymy has been suggested to me as probable by some other worker (especially G. P. Holland) and confirmed by me; I have not thought it necessary to make a specific acknowledgment in such instances, because the final responsibility for such synonymies is mine.

#### Family COPTOPSYLLIDAE

*Neocoptopsylla* Wagner, 1932 = *Coptopsylla* Jordan and Rothschild, 1908. Admittedly the type species, *N. wassilievi* Wagner, is a good deal more distinct from the other species than these are from one another, but its characteristics do not seem to merit generic rank and its retention as a subgenus would serve no particularly useful purpose in so small a group as *Coptopsylla*.

*Coptopsylla lamellifer fallax* Ioff and Tiflov, 1934 = *C. lamellifer ardua* Jordan and Rothschild, 1915. The fact that the latter name was based on males whose characteristics were altered by parasitic castration in no way affects its validity.

#### Family VERMIPSYLLIDAE

*Arctopsylla* Wagner, 1930, is extremely difficult to separate from *Chaetopsylla* Kohaut, 1903, because the two characters that have been used to define it (the permanent, instead of deciduous, frontal tubercle and the number of segments in the labial palp) do not always go together. Provisionally I accept it as a subgenus of *Chaetopsylla* and refer to it those species in which the frontal tubercle is permanent.

*Pulex ursi* Rothschild, 1902 = *Chaetopsylla* (*Arctopsylla*) *tuberculaticeps ursi* (Rothschild).

*Vermipsylla strandi* Wahlgren, 1903 = *Chaetopsylla* (*A.*) *tuberculaticeps* (Bezzi), 1890.

#### Family LEPTOPSYLLIDAE

*Ctenopsyllus fallax* Rothschild, 1902 = *Peromyscopsylla silvatica fallax* (Rothschild).

*Typhlopsylla spectabilis* Rothschild, 1898 = *Peromyscopsylla silvatica spectabilis* (Rothschild).

*Pectinocentrus adalis* Jordan, 1929 = *Pectinocentrus pectiniceps* (Wagner), 1893.

#### Family ISCHNOPSYLLIDAE

*Ischnopsyllus noctilionis* Costa Lima, 1920 (referred by Pinto, 1930, to *Hormopsylla*) be-

longs to neither of these genera but is almost certainly a *Ptilopsylla*. No specimens have been available, but Dr. Costa Lima has kindly provided photo-micrographs of the holotype.

*Aptilopsylla carlsbadensis* Ewing, 1940 = *Sternopsylla texana* (C. Fox), 1914 (information kindly supplied by Lt. Col. R. Traub).

*Eptesopsylla* I. Fox, 1940 = *Nycteridopsylla* Oudemans, 1906.

*Nycteridopsylla eusarca major* Rothschild, 1909 = *Nycteridopsylla eusarca* Dampf, 1908. In 1949 (Entomologist 82: 134-136) I placed *eusarca* as a synonym of *Nycteridopsylla pungens* (Walckenaer), 1802, and I still think that this is probably correct. But there is a certain element of doubt in the matter and in any case Walckenaer's name has not been used (except on this one occasion) for very many years. I therefore intend to ask the International Commission on Zoological Nomenclature to suppress the name *Pulex pungens* Walckenaer, 1802, and pending their decision I intend to revert to calling the flea *N. eusarca* Dampf.

*Myodopsylloides* Augustson, 1941 = *Myodopsylla* Jordan and Rothschild, 1911.

*Myodopsylla notialis* Jordan, 1937 = *Myodopsylla wolffsohni wolffsohni* (Rothschild), 1903.

*Ischnopsyllus liui* Chao, 1947 = *Ischnopsyllus liae* Jordan, 1941.

*Ischnopsyllus tateishii* Sugimoto, 1933 = *Ischnopsyllus indicus* Jordan, 1931.

*Ischnopsyllus ashworthii* Waterston, 1913 = *Rhinolophopsylla ashworthi* (Waterston).

*Ischnopsyllus ectopus* Jordan, 1937 = *Rhinolophopsylla ectopa* (Jordan).

#### Family HYPSPHthalmidae

*Chiaetopsylla numae klaveriana* De Meillon, 1940 = *Chiaetopsylla numae* (Rothschild), 1904.

*Chiaetopsylla caffrarica* De Meillon, 1940, and *C. crassus* De Meillon, 1940 = *C. rossi* (Waterston), 1909 (information kindly supplied by Dr. De Meillon).

*Chiaetopsylla couchae* De Meillon, 1940 = *C. godfreyi* Waterston, 1913.

#### Family HYSTRICHOPSYLLIDAE

##### Subfamily Hystrichopsyllinae

*Pulex gigas* Kirby, 1837, has been variously placed. Baker (1895) used the name for a species now referred to the Neopsyllinae; Rothschild (1915) thought it a *Stenoponia*; and Jordan (1929) considered it to be a *Hystrichopsylla*.



Baker's suggestion is certainly wrong, for the flea undoubtedly belongs to the Hystrichopsyllidae, but the description and figure are not good enough to make it possible to decide with any certainty whether it is a *Stenoponia* or a *Hystrichopsylla*, though the latter genus seems a little more likely than the former. The name should be discarded until topotypical specimens can be obtained.

*Saphiopsylla* Jordan, 1931 = *Atyphloceras* Jordan and Rothschild, 1915, but could be recognized as a subgenus if this would serve any particular purpose.

*Atyphloceras artius* Jordan, 1933, and *A. felix* Jordan, 1933 = *A. multidentatum* (C. Fox), 1909.

#### Subfamily Dinopsyllinae

*Dinopsyllus lypusus* Jordan and Rothschild, 1913 = *Dinopsyllus ellobius lypusus* Jordan and Rothschild.

*Dinopsyllus tenax* Jordan, 1930 = *D. longifrons tenax* Jordan.

*Dinopsyllus semnus* Jordan, 1937 = *D. hirsutus semnus* Jordan.

#### Subfamily Listropsyllinae

*Ceratophyllus stygius* Rothschild, 1908 = *Listropsylla dolosa* Rothschild, 1907.

#### Subfamily Rhadinopsyllinae

*Corypsylloides* Hubbard, 1940 = *Corypsylla* C. Fox, 1908. It could be accepted as a subgenus, principally on the presence of pseudosetae under the collar of the metanotum, but there is little object in recognizing subgenera in a genus containing only three known species.

*Corypsylla setosifrons* Stewart, 1940 = *Corypsylla ornata* C. Fox, 1908 (information kindly supplied by Dr. E. W. Jameson).

*Nearctopsylla hygini laurentina* Jordan and Rothschild, 1923 = *N. g. genalis* (Baker), 1904.

*Rhadinopsylla* s.g. *Rangulopsylla* Darskaya, 1949 = *Rectofrontia* Wagner, 1930.

*Actenophthalmus* C. Fox, 1925, is at most a subgenus of *Rectofrontia* Wagner, 1930, and is provisionally recognized in that grade.

*Micropsylloides* Ewing, 1938, is a subgenus of *Rectofrontia* Wagner, 1930.

*Rhadinopsylla bureschi* Jordan, 1929 = *Rectofrontia fraterna bureschi* (Jordan), *Rhadinopsylla casta* Jordan, 1928 = *Rectofrontia fraterna casta* (Jordan), and *Rhadinopsylla integella* Jordan and Rothschild, 1921 = *Rectofrontia fraterna integella* (Jordan and Rothschild). *Rhadinopsylla (Rectofrontia) integella concava* Ioff and Tiflov, 1946, and *R.(R.)integella pilosa* Ioff and Tiflov, 1946, of which specimens have not been available, are presumably also subspecies of *Rectofrontia fraterna* (Baker), 1895.

*Micropsylla* Dunn, 1923, is a subgenus of *Rectofrontia* Wagner, 1930.

#### Subfamily Anomiopsyllinae

*Megarhroglossus procus oregonensis* Hubbard, 1947 = *Megarhroglossus procus* Jordan and Rothschild, 1915.

*Megarhroglossus divisus wallowensis* Hubbard, 1947 = *Megarhroglossus divisus divisus* (Baker), 1898 (information kindly supplied by Lt. Col. Traub).

*Anomiopsyllus congruens* Stewart, 1940 = *Anomiopsyllus falsicalifornicus congruens* Stewart.

MYCOLOGY.—On the fungus genera *Titaea*, *Monogrammia*, and *Araneomyces*.

S. C. DAMON,<sup>1</sup> Quartermaster Depot, Philadelphia, Pa. (Communicated by G. W. Martin.)

While studying genera of staurosporous Moniliaceae, a striking similarity between *Monogrammia miconiae*, *Araneomyces acariferus*, and species of *Titaea* was noted. In-

<sup>1</sup> I wish to express my appreciation to Dr. W. L. White, of the Farlow Herbarium, for the opportunity to study the type specimen of *Araneomyces acariferus*, and to Dr. Leland Shanor, of the University of Illinois, for his cooperation in searching for the type specimen of *Monogrammia miconiae* among the Stevens collections.

vestigation into all available information has led to the reduction of *Monogrammia* and *Araneomyces*, both monotypic genera, to the synonymy of *Titaea*, with the transfer of their species to that genus. In this connection, type material of *Titaea clarkeae* Ell. and Ev. (originally published as *T. clarkei*) has been re-examined, and it has been shown to be congeneric with other species assigned to the genus.

*Titaea* was erected for a staurosporous fungus growing parasitically, according to Saccardo (1876), on a species of *Dimerosporium*. In addition to the type species, *T. callispora*, four others had been added prior to the two recent papers by Hansford (1944, 1946), in which five more species were described. The four older species were treated with particular reference to the morphology of their conidia by Ingold (1942) in connection with his treatment of *Tetracladium*. Ingold agreed in part with the older opinion advanced by von Höhnel (1914) that *T. maxilliformis* Rostrup was so distinct from *T. callispora* as to warrant its removal from *Titaea*. Höhnel, accordingly, erected the genus *Maxillospora* for this species, but Ingold concluded from his studies on *Tetracladium marchalianum* that the two species were congeneric and transferred Rostrup's fungus to *Tetracladium*. At that time he characterized the genus not on an ecological basis, as had been done previously, but on the morphology of its spores, which, he said, had branches arising or diverging from a central axis as in *Titaea* but differing in having a single upwardly directed cell or process arising (at some distance from the central axis) from one of the branches. This extra-axial process is somewhat hard to determine in *Tetracladium setigerum* because of the difficulty in defining the central axis in that species. Furthermore, the different morphology of this process in the species of the genus is also somewhat confusing. It would seem that *Tetracladium* as an ecological genus could be distinguished from *Titaea* more easily than on its present morphological basis; but a conclusive discussion of this matter must await study of more

forms than are presently available. With the exception of *T. marchalianum*, which has filiform processes like those of *T. clarkeae*, the spores of *Tetracladium* species have a somewhat cheiroid appearance, whereas the spores of *Titaea* have upwardly and downwardly, outwardly directed arms suggestive of no particular structure. Another feature of *Titaea* spores which separates them from those of *Tetracladium* is the fact that the central axis is 2-celled and forms an integral part of the spore, whereas in *Tetracladium* the central axis, though definable, sometimes lacks this distinctness. If these are the characteristics of *Titaea* and *Tetracladium* spores, it will be noted that there are no suitable distinctions between those of *Titaea* and *Monogrammia* or *Araneomyces*. Unfortunately, *Monogrammia miconiae* is known only from its original description and illustration (reproduced in Fig. 1, A) and was described by Stevens (1917) for a fungus occurring in association with *Hyalosphaeria miconiae* in Puerto Rico. *Araneomyces acariferus*, of which type material exists in the Höhnel collection in the Farlow Herbarium,<sup>1</sup> was based upon (1909) a fungus found on stromata of *Rosellinia miconiae*. The spores of this fungus are illustrated in Fig. 1, B. From the spores of both *A. acariferus* and *M. miconiae* it is obvious that they are only specifically different from other species of *Titaea*. Furthermore, both occur on foliicolous ascomycetes in tropical regions, as do almost all other species of *Titaea*; and though it is possible that future studies will provide evidence by which *Titaea* may be divided into more homogeneous groups it is felt that *Araneomyces* and *Monogrammia* should be merged under the

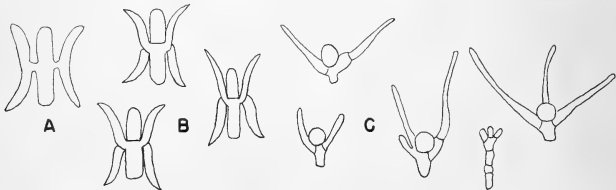

FIG. 1.—A, Spore of *Monogrammia miconiae* redrawn from Stevens (1917); B, spores of *Araneomyces acariferus* drawn from type material ( $\times 1,000$ ); C, spores of *Titaea clarkeae* drawn from type material ( $\times 750$ ) (reduced approximately  $\frac{1}{3}$ ).

older name. Although there is a striking similarity between the spores of both species, there can be no evaluation of this because of the lack of material of *M. miconiae*, and it is felt that they should both be maintained as valid species of *Titaea*. The following two new combinations are therefore proposed:

*Titaea acarifera* (von Höhnelt) comb. nov.

*Araneomyces acariferus* von Höhnelt, Sitzb. Akad. Wiss. Wien **118**: 894, illus. 1909.

*Titaea miconiae* (Stevens) comb. nov.

*Monogrammia miconiae* Stevens, Trans. Illinois Acad. Sci. **10**: 202, illus. 1917.

Although well described by Ellis and Everhart (1891), *Titaea clarkeae* Ell. and Ev. is discussed here because it has been found that some specimens under this label in the North American Fungi, no. 2466, have material of hyphomycetes other than *T. clarkeae* present; and because Ingold (1942) remarked upon the lack of spore illustrations upon which to base a judgment of the species. *T. clarkeae*, though not foliicolous, is found in association with a species of *Dichaena* and possesses spores (Fig. 1, C) most like those of *T. doidgeae* Hansford in that the branches are long and filiform, but

differing from that species in other details. It possesses the 2-celled axis typical of *Titaea* of which the upper cell is globose as in the spores of *T. toddaliae*, and *T. ugandae*.

It is felt that this is a typical species of *Titaea*, and, so far as is known, it is the only species of the genus occurring in continental North America.

#### REFERENCES

- ELLIS, J. B., and EVERHART, B. M. *New species of fungi from various localities*. Proc. Acad. Nat. Sci. Philadelphia **43**: 76-93. 1891.
- HANSFORD, C. G. *Contributions toward the fungus flora of Uganda. V. Fungi Imperfecti*. Proc. Linn. Soc. London **155**: 34-67, illus. 1944.
- . *The foliicolous ascomycetes, their parasites and associated fungi*. Myc. Paper (C.M.I.) no. 15: 240 pp., illus. 1946.
- INGOLD, C. T. *Aquatic hyphomycetes of decaying alder leaves*. Trans. Brit. Myc. Soc. **25**: 339-417, illus. 1942.
- VON HÖHNELT, F. *Fragmente zur Mykologie (VII. Mitt.)*. Sitzb. Akad. Wiss. Wien **118**: 813-904, illus. 1909.
- . *Fragmente zur Mykologie (XVI. Mitt.)*. Sitzb. Akad. Wiss. Wien **123**: 49-155. 1914.
- SACCARDO, P. A. *Fungi veneti novi vel critici*. Nuov. Giorn. Bot. Ital., ser. 5, **8**: 181-211. 1876.
- STEVENS, F. L. *Porto Rican fungi, old and new*. Trans. Illinois Acad. Sci. **10**: 162-218, illus. 1917.

## PROCEEDINGS OF THE ACADEMY AND AFFILIATED SOCIETIES

### ANTHROPOLOGICAL SOCIETY

The Anthropological Society of Washington held its annual business meeting on January 14, 1952, and elected the following officers: President, WALDO R. WEDEL (reelected); Vice-President, GEORGE M. FOSTER, JR. (reelected); Secretary, WILLIAM H. GILBERT, JR. (reelected); Treasurer, MARGARET C. BLAKER (reelected); Councilors to the Board of Managers, JOHN C. EWERS (reelected), JOHN A. JONES, MARK H. WATKINS (reelected), GEORGE TRAGER (reelected), MARIAN L. VANDERBILT (reelected), and SIDNEY ADAMS (reelected); Representative to the Washington Academy of Sciences, WALDO R. WEDEL (reelected).

A report of the membership and activities of the Society since the last annual meeting follows.

The total membership totaled 98, an increase of 8 over a year ago. Thirteen new members were elected during the year as follows: HARRY W. BASEHART; DR. DIETHER VON DEN STEINEN; DR. JOHN ALAN JONES; MRS. LILIAN FULLER JONES; CHARLES H. FAIRBANKS; JEAN HUSSEY, MRS. MAURY H. TRAVIS; REV. C. M. LEWIS; MRS. MARGARET C. GILBERT; DR. HAROLD HENRY PLOUGH; MRS. EDITH CROWELL TRAGER; DR. MARIAN W. SMITH; and RALPH KEPLER LEWIS.

Death of two members during the year was reported: DR. ANTONIO GOUBAUD-CARRERA, Ambassador from Guatemala to the United States, on March 9, 1951, and MRS. ALICE L. L. FERGUSON, artist, archeologist, and writer, on June 7, 1951.

The report of the Treasurer for the year ended December 31, 1951, follows:

*Credit:*

Balance forwarded	\$1,634.11
Withdrawn, Perpetual Building Association	1,986.50
Sale of U. S. Savings Bond, Series G	486.50
Dues collected	135.00
Dividends, Investment Co. of America	50.60
Year-end dividend, Investment Co. of America	61.60
Dividends, Washington Sanitary Housing Co.	18.00
Dividends, Massachusetts Investor's Trust	92.00
Cash balance from capital gain dividend, Massachusetts Investor's Trust	19.41
<b>Total</b>	<b>\$4,483.72</b>

*Debit:*

Purchase of securities	\$3,251.10
Deposited in Perpetual Building Association	486.50
AAA dues paid for Secretary, Treasurer, and one life member	15.00
Refund to AAA	1.00
ASW share in Science Calendar	1.00
Speakers	41.00
Incidental meeting expenses	14.00
Printing and mailing notices	95.05
Florist's bill	10.20
Treasurer's expenses (stamped envelopes and postage)	5.00
<b>Total</b>	<b>\$3,919.85</b>

Balance (in bank)..... \$ 563.87

*Assets:*

Funds invested in Perpetual Building Association (with interest to Dec. 31, 1951)	\$ 536.12
4 shares Washington Sanitary Housing Co. (including stock dividend of 2 shares, Nov. 21, 1951) @ \$100 per share	400.00
110 shares Investment Co. of America @ \$12.46 per share	1,370.60
50 shares Massachusetts Investor's Trust @ \$37.61 per share	1,880.50
1 share Massachusetts Investor's Trust @ \$35.59 per share	35.59
Cash in bank	563.87
<b>Total as of Dec. 31, 1951</b>	<b>\$4,786.68</b>
Corrected Total* as of Dec. 31, 1950	4,334.11
<b>Increase</b>	<b>452.57</b>

\*The report of 1950 erroneously showed a total of \$5,674.96, an excess of \$1,340.85. This amount, resulting from the sale of Washington Sanitary Improvement Co. stock, was listed as such, but was also included in the figure representing cash in bank.

Programs during the year were arranged by Dr. Eugene C. Worman, chairman of the program committee, and by the Secretary. All meetings were held at the U. S. National Museum. Speakers and the titles of papers presented before the Society in 1951 were as follows:

January 24, Dr. IRVING ROUSE, *Archeological excavations in Venezuela* (with motion pictures).

February 22, Dr. CLIFFORD EVANS, *Prehistory to history at the mouth of the Amazon River* (with slides).

March 20, Mrs. ELDEN E. BILLINGS, Mexican musical Indians.

April 17, Dr. REGINA FLANNERY, Dr. WILLIAM N. FENTON, and Dr. WILLIAM H. GILBERT, *The Eastern Woodland Indians, then and now*.

May 15, Dr. GEORGE TRAGER, *Linguistic and ethnological history of the Southwest, some methodological considerations*.

October 16, Dr. DONALD N. WILBER, *Iran and Afghanistan, a challenge to the ethnologist* (with slides).

November 29, Dr. MARIAN W. SMITH, *The western heritage in Indian and Pakistani nationalism*.

Plans for perfecting and improving the Society's system of accounts were presented at the annual meeting on January 14, 1952. The President was authorized to appoint a planning committee to expand the activities of the Society in conjunction with the program committee. In November 1951 President Wedel extended an invitation in behalf of the Society to the American Anthropological Association to hold its annual meeting in 1953 at Washington, D. C.

WILLIAM H. GILBERT, *Secretary*.

## Officers of the Washington Academy of Sciences

President.....	WALTER RAMBERG, National Bureau of Standards
President-elect.....	F. M. SETZLER, U. S. National Museum
Secretary.....	F. M. DEFANDORF, National Bureau of Standards
Treasurer.....	HOWARD S. RAPPLEYE, U. S. Coast and Geodetic Survey
Archivist.....	JOHN A. STEVENSON, Plant Industry Station
Custodian and Subscription Manager of Publications	HARALD A. REHDER, U. S. National Museum

### Vice-presidents Representing the Affiliated Societies:

Philosophical Society of Washington.....	A. G. McNISH
Anthropological Society of Washington.....	WALDO R. WEDEL
Biological Society of Washington.....	HUGH T. O'NEILL
Chemical Society of Washington.....	JOHN K. TAYLOR
Entomological Society of Washington.....	FREDERICK W. POOS
National Geographic Society.....	ALEXANDER WETMORE
Geological Society of Washington.....	A. NELSON SATRE
Medical Society of the District of Columbia.....	FRED O. COE
Columbia Historical Society.....	GILBERT GROSVENOR
Botanical Society of Washington.....	LEE M. HUTCHINS
Washington Section, Society of American Foresters.....	WILLIAM A. DAYTON
Washington Society of Engineers.....	CLIFFORD A. BETTS
Washington Section, American Institute of Electrical Engineers.....	A. H. SCOTT
Washington Section, American Society of Mechanical Engineers.....	RICHARD S. DILL
Helminthological Society of Washington.....	L. A. SPINDLER
Washington Branch, Society of American Bacteriologists.....	ANGUS M. GRIFFIN
Washington Post, Society of American Military Engineers.....	FLOYD W. HOUGH
Washington Section, Institute of Radio Engineers.....	HERBERT G. DORSEY
District of Columbia Section, American Society of Civil Engineers	MARTIN A. MASON
District of Columbia Section, Society for Experimental Biology and Medicine	N. R. ELLIS

### Elected Members of the Board of Managers:

To January 1953.....	C. F. W. MUESEBECK, A. T. MCPHERSON
To January 1954.....	SARA E. BRANHAM, MILTON HARRIS
To January 1955.....	ROGER G. BATES, W. W. DIEHL

Board of Managers..... All the above officers plus the Senior Editor

Board of Editors and Associate Editors..... [See front cover]

Executive Committee.... WALTER RAMBERG (chairman), F. M. SETZLER, H. S. RAPPLEYE,  
WILLIAM A. DAYTON, F. M. DEFANDORF

Committee on Membership. E. H. WALKER (chairman), M. S. ANDERSON, CLARENCE COT-  
TAM, R. C. DUNCAN, JOHN FABER, G. T. FAUST, I. B. HANSEN, FRANK KRACEK, D. B.  
JONES, E. G. REINHARD, REECE I. SAILER, LEO A. SHINN, F. A. SMITH, HEINZ SPECHT,  
H. M. TRENT, ALFRED WEISSLER

Committee on Meetings.... H. W. WELLS (chairman), WM. R. CAMPBELL, W. R. CHAP-  
LINE, D. J. DAVIS, H. G. DORSEY, O. W. TORRESON

Committee on Monographs (W. N. FENTON, chairman):  
To January 1953..... R. W. IMLAY, P. W. OMAN  
To January 1954..... S. F. BLAKE, F. C. KRACEK  
To January 1955..... W. N. FENTON, ALAN STONE

Committee on Awards for Scientific Achievement (J. R. SWALLEN, general chairman):  
For Biological Sciences..... J. R. SWALLEN (chairman), L. M. HUTCHINS,  
MARGARET PITTMAN, F. W. POOS, L. P. SCHULTZ

For Engineering Sciences..... R. C. DUNCAN (chairman), A. C. FIELDNER,  
WAYNE C. HALL, J. W. MCBURNEY, O. S. READING, H. L. WHITEMORE

For Physical Sciences..... L. A. WOOD (chairman), P. H. ABELSON,  
F. S. DAFT, GEORGE W. IRVING, JR., J. H. McMILLEN

For Teaching of Science.... M. A. MASON (chairman), F. E. FOX, M. H. MARTIN  
Committee on Grants-in-aid for Research..... L. E. YOCUM (chairman), H. N. EATON,  
K. F. HERZFELD

Committee on Policy and Planning:  
To January 1953..... W. A. DAYTON (chairman), N. R. SMITH  
To January 1954..... H. B. COLLINS, JR., W. W. RUBEY  
To January 1955..... L. W. PARR, F. B. SILSBEER

Committee on Encouragement of Science Talent (A. T. MCPHERSON, chairman):  
To January 1953..... A. H. CLARK, F. L. MOHLER  
To January 1954..... J. M. CALDWELL, W. L. SCHMITT  
To January 1955..... A. T. MCPHERSON, W. T. READ

Representative on Council of A. A. A. S..... F. M. SETZLER  
Committee of Auditors..... C. L. GAZIN (chairman), LOUISE M. RUSSELL, D. R. TATE  
Committee of Tellers... GEORGE P. WALTON (chairman), GEORGE H. COONS, C. L. GARNER

## CONTENTS

	Page
ETHNOLOGY.—Animal names, anatomical terms, and some ethnozoology of the Flathead Indians. GEORGE F. WEISEL.....	345
PALEONTOLOGY.—The type species of the gastropod genus <i>Protostylus</i> . ROGER L. BATTEN.....	355
PALEONTOLOGY.—Morphology of the test in the foraminiferal genus <i>Tristix</i> Macfayden. ALFRED R. LOEBLICH, JR., and HELEN TAPPAN.....	356
PALEONTOLOGY.—A rare Tertiary glycymerid from South Carolina and Florida. DAVID NICOL.....	362
ENTOMOLOGY.—Notes on synonymy in Siphonaptera. G. H. E. HOPKINS.....	363
MYCOLOGY.—On the fungus genera <i>Titaea</i> , <i>Monogrammia</i> , and <i>Araneomyces</i> . S. C. DAMON.....	365
PROCEEDINGS: Anthropological Society.....	367



# JOURNAL

OF THE

# WASHINGTON ACADEMY OF SCIENCES

## BOARD OF EDITORS

WILLIAM F. FOSHAG  
U.S. NATIONAL MUSEUM

J. P. E. MORRISON  
U.S. NATIONAL MUSEUM

JOHN C. EWERS  
U.S. NATIONAL MUSEUM

## ASSOCIATE EDITORS

F. A. CHACE, JR.  
BIOLOGY

MIRIAM L. BOMHARD  
BOTANY

J. I. HOFFMAN  
CHEMISTRY

R. K. COOK  
PHYSICS AND MATHEMATICS

T. P. THAYER  
GEOLOGY

PHILIP DRUCKER  
ANTHROPOLOGY

C. W. SABROSKY  
ENTOMOLOGY

PUBLISHED MONTHLY  
BY THE

WASHINGTON ACADEMY OF SCIENCES  
MOUNT ROYAL & GUILFORD AVES.  
BALTIMORE, MARYLAND

## Journal of the Washington Academy of Sciences

This JOURNAL, the official organ of the Washington Academy of Sciences, publishes: (1) Short original papers, written or communicated by members of the Academy; (2) proceedings and programs of meetings of the Academy and affiliated societies; (3) notes of events connected with the scientific life of Washington. The JOURNAL is issued monthly. Volumes correspond to calendar years.

*Manuscripts* may be sent to any member of the Board of Editors. It is urgently requested that contributors consult the latest numbers of the JOURNAL and conform their manuscripts to the usage found there as regards arrangement of title, subheads, synonyms, footnotes, tables, bibliography, legends for illustrations, and other matter. Manuscripts should be typewritten, double-spaced, on good paper. Footnotes should be numbered serially in pencil and submitted on a separate sheet. The editors do not assume responsibility for the ideas expressed by the author, nor can they undertake to correct other than obvious minor errors.

*Illustrations* in excess of the equivalent (in cost) of one full-page halftone are to be paid for by the author.

*Proof.*—In order to facilitate prompt publication one proof will generally be sent to authors in or near Washington. It is urged that manuscript be submitted in final form; the editors will exercise due care in seeing that copy is followed.

*Unusual cost* of foreign, mathematical, and tabular material, as well as alterations made in the proof by the author, may be charged to the author.

*Author's Reprints.*—Reprints will be furnished in accordance with the following schedule of prices (approximate):

Copies	4 pp.	8 pp.	12 pp.	16 pp.	20 pp.	Covers
100	\$3.25	\$6.50	\$ 9.75	\$13.00	\$16.25	\$3.00
200	6.50	13.00	19.50	26.00	32.50	6.00
300	9.75	19.50	29.25	39.00	48.75	9.00
400	13.00	26.00	39.00	52.00	65.00	12.00

*Subscriptions* or requests for the purchase of back numbers or volumes of the JOURNAL or the PROCEEDINGS should be sent to HARALD A. REHDER, Custodian and Subscription Manager of Publications, U. S. National Museum, Washington 25, D. C.

*Subscription Rates* for the JOURNAL.—Per year..... \$7.50

Price of back numbers and volumes:	Per Vol.	Per Number
Vol. 1 to vol. 10, incl.—not available*.....	—	—
Vol. 11 to vol. 15, incl. (21 numbers per vol.).....	\$10.00	\$0.70
Vol. 16 to vol. 22, incl. (21 numbers per vol.).....	8.00	0.60
Vol. 23 to current vol. (12 numbers per vol.).....	7.50	0.90

\* Limited number of complete sets of the JOURNAL (vol. 1 to vol. 42, incl.) available for sale to libraries at \$356.00.

MONOGRAPH No. 1, "The Parasitic Cuckoos of Africa," by Herbert Friedmann. \$4.50

PROCEEDINGS, vols. 1-13 (1899-1911) complete..... \$25.00

Single volumes, unbound..... 2.00

Single numbers..... .25

*Missing Numbers* will be replaced without charge provided that claim is made to the Treasurer within 30 days after date of following issue.

*Remittances* should be made payable to "Washington Academy of Sciences" and addressed to the Treasurer, H. S. RAPPLEYE, 6712 Fourth Street, N.W., Washington 12, D.C.

*Exchanges.*—The Academy does not exchange its publications for those of other societies.



# JOURNAL OF THE WASHINGTON ACADEMY OF SCIENCES

VOLUME 42

December 1952

No. 12

BOTANY.—Notes on *Fraxinus* (ash) in the United States. ELBERT L. LITTLE, JR., U. S. Forest Service.

Under a conservative treatment the genus *Fraxinus* L. (family Oleaceae), common name ash, contains 16 native species with 2 additional important varieties in the United States. This article presents taxonomic and nomenclatural notes on 11 of these, including publication of a new species from the Mexican border of Arizona and Sonora, reduction of *F. lowellii* to a variety of *F. anomala*, inclusion of *F. dipetala* as a tree species, a new combination for a Mexican variation of *F. greggii*, acceptance of the older name *F. latifolia* for *F. oregona*, addition of *F. papillosa* as a native tree species and State record for Arizona, restoration of *F. profunda* in place of *F. tomentosa*, and reduction of several varieties to synonymy.

In the last formal descriptive and illustrated treatment of *Fraxinus* in the United States, Sargent (Man. Trees North Amer. ed. 2, 833–853, illus. 1922; ed. 2, corr., 833–853, illus. 1926) accepted 19 native species and 10 varieties, of which only 2 varieties were illustrated. Two of the species merely were mentioned, *F. dipetala* Hook. & Arnott as a shrub and *F. papillosa* Lingelsh. of Mexico as known from a single plant, possibly a shrub, along the southwestern border of New Mexico. Sudworth (Check List Forest Trees U. S. 224–228. 1927) followed Sargent, except that the 2 shrubby species and 1 variety (*F. cuspidata* var. *macro-petala*) were omitted.

Later authors have united several names. Fernald (Rhodora 40: 450–452, t. 528. 1938) took up *F. tomentosa* Michx. f. for *F. profunda* (Bush) Bush (*F. michauxii* Britton), a change rejected here. Kearney and Peebles (Fl. Pl. Ferns Ariz. 672. 1942) united *F. standleyi* Rehd. with *F. velutina* Torr., and Benson and Darrow (Man. Southwest. Desert Trees Shrubs 260, 377. 1945) re-

duced the varieties of the latter to synonymy. Fernald (Rhodora 50: 186–190. 1948) placed *F. pauciflora* Nutt. under *F. caroliniana* Mill., while distinguishing varieties and forms of the latter.

Jonathan W. Wright, of the United States Forest Service, has published the following two articles on his experimental studies in *Fraxinus*: "Genotypic Variation in White Ash," Journ. Forestry 42: 489–495. 1944; "Ecotypic Differentiation in Red Ash," Journ. Forestry 42: 591–597. 1944. In the former he united *F. biltmoreana* Beadle with *F. americana* L., and in the latter reduced *F. pennsylvanica* var. *lanceolata* to synonymy. I am indebted to him for further suggestions.

In checking the nomenclature of *Fraxinus* I have examined the specimens at the National Herbarium (US), of the United States National Museum, which contains many types, isotypes and other important specimens in this genus. The synonymy given here is that directly related to the names discussed. Lists of additional and especially old synonyms were compiled by Sargent (Silva North Amer., 14 vols., illus. 1891–1902) and Rehder (Bibliog. Cult. Trees Shrubs, 825 pp. 1949).

Of the 16 native species of *Fraxinus* accepted here, *Fraxinus nigra* Marsh. and *F. quadrangulata* Michx. are clearly distinct and need not be mentioned further. *F. texensis* (A. Gray) Sarg. of Texas and Oklahoma is a southwestern xeric ash closely related to *F. americana* but with fewer and smaller leaflets and originally named as a variety of the latter. Similarly, *F. berlandieriana* A. DC. is a xeric Texan and Mexican relative of *F. pennsylvanica* with reduced leaflets and has been regarded also as a variety of green ash. *F. cuspidata* Torr. consists of 2 varie-

ties, var. *cuspidata* and var. *macropetala* (Eastw.) Rehd. Var. *serrata* Rehd. was reduced to a synonym of the former by Standley (Trees Shrubs Mex. 1135. 1924). Notes on the remaining 11 species follow in alphabetical order.

**Fraxinus americana L.** WHITE ASH

*Fraxinus americana* L., Sp. Pl. 1057. 1753.

*Fraxinus juglandifolia* Lam., Encycl. Méth. Bot. 2: 548. [1788.]

*Fraxinus americana juglandifolia* [(Lam.)] Browne, Trees Amer. 398. 1846.

*Fraxinus curtissi* Vasey, Cat. Forest Trees U. S. 20. 1876; U. S. Commr. Agr. Rpt. 1875: 168. 1876; nom. provisor. et subnud.

*Fraxinus americana* var. *microcarpa* A. Gray, Synopt. Fl. North Amer. 2 (1): 75. 1878.

*Fraxinus biltmoreana* Beadle, Bot. Gaz. 25: 358. 1898.

*Fraxinus catawbiensis* Ashe, Bot. Gaz. 33: 230. 1902.

*Fraxinus americana* var. *subcoriacea* Sarg., Bot. Gaz. 67: 241. 1919.

*Fraxinus americana* var. *crassifolia* Sarg., Man. Trees North Amer. ed. 2, 841. 1922.

*Fraxinus americana* var. *ascidiata* A. M [eunissier], Gard. Chron., ser. 3, 76: 335, fig. 122. 1924.

*Fraxinus americana* var. *biltmoreana* (Beadle) J. Wright ex Fern., Rhodora 49: 159. 1947.

*Fraxinus americana* f. *ascidiata* (Meunissier) Rehd., Bibliog. Cult. Trees Shrubs 557. 1949.

The minor variations of *Fraxinus americana* cited above need not be distinguished except in special studies. Biltmore ash, *F. biltmoreana*, which has been accepted as a species, has already been reduced to synonymy. Jonathan W. Wright (Journ. Forestry 42: 489-895. 1944) distinguished three ecotypes in *F. americana*. He experimented with Biltmore ash and white ash, growing progenies from seeds of both from different localities and found that the former, separable only by pubescence and absent northward, was not a good species, as the seed of one may give the other. Thus, he concluded that Biltmore ash, which was not distinguished in lumbering, need not be separated either in taxonomy or silviculture. In 1941 Wright annotated the type collection of *F. biltmoreana* (Biltmore, N. C., Oct. 1895, No. 4049; type in US) as *F. americana* var. *biltmoreana* but did not formally make varietal reduction. Fernald afterward published this combination from Wright's herbarium name. Independently, Donald C. Peattie informed me by letter in 1946 that he knew this tree well in the field and thought it should be made a variety or synonym of *F. americana*.

The small-fruited southeastern variation was first named *F. curtissi* Vasey, a doubtful new species provisionally published with inadequate very brief description and not afterward accepted. *F. americana* var. *microcarpa* A. Gray, with "fruit (seemingly full grown but seedless) remarkably small, half to two-thirds inch long," was based partly upon the same type collection (*Curtiss, Eufaula, Ala., in 1875, US*). Though the material may be teratological in part, I find filled as well as empty fruits in this collection. Variations in size of fruit occur in several species and scarcely merit recognition.

Var. *juglandifolia* (Lam.) Browne, with more or less serrate or crenate-serrate leaflets and more common northward, and var. *subcoriacea* Sarg. (var. *crassifolia* Sarg., corrected in Sarg., Man. Trees North Amer. ed. 2., corr. 841. 1926), with thicker leaves silvery white beneath, and noted from three localities in different States, may be of interest in horticulture but were not even mentioned by Fernald in Gray's Manual (ed. 8: 1148. 1950). The form *ascidiata* (Meunissier) Rehd. was a local dominant mutant near Cold Spring Harbor, Long Island, N. Y., with leaflets partly pitcher-shaped at base.

Sterile specimens of *F. americana* and *F. pennsylvanica* can be distinguished readily by the microscopic appearance of the lower epidermis of the leaflets, as shown in direct examination or by collodion leaf peels. The characteristic whitish lower leaf surface of the former appears under high magnification to be a solid mass of whitish beads or sleetlike particles, consisting of minute opaque papillae of each epidermal cell. In *F. pennsylvanica*, the lower leaf surface is greenish and under high magnification is less rough, though often hairy or with minute peltate scales or irregular masses of papillae. This useful diagnostic character was brought to my attention by Jonathan W. Wright and is further mentioned under *F. papillosa*.

**Fraxinus anomala** Torr. var. **lowellii** (Sarg.) Little, comb. nov. LOWELL ASH

*Fraxinus lowellii* Sarg. in Rehd., Proc. Amer. Acad. Arts Sci. 53: 211. 1917.

*Fraxinus lowellii* Sarg. is known only from northern and central Arizona, with type locality Oak Creek Canyon about 20 miles south of Flagstaff, Coconino County. Before publishing the name, Sargent (Rhodora 19: 23. 1917) observed that this ash is somewhat intermediate between *F. quadrangulata* Michx. of the East

and *F. anomala* Torr. (ex Wats. in King, Rpt. Geol. Expl. 40th Par. 5: 283. 1871), singleleaf ash, of southwestern deserts. He recorded the number of leaflets of *F. lowellii* as 5 or rarely 3 but illustrated also 7 (Man. Trees North Amer. ed. 2, corr. 836, fig. 740. 1926). An isotype of *F. lowellii* (Rehder 53, US) has the leaflets mostly 5, a few 3, and one leaf with 2 leaflets and shows variation in shape of leaflets from nearly orbicular to obovate, ovate, and lanceolate.

Goodding (Notes on native and exotic plants in Region 8, p. 120. U.S. Dept. Agr. Soil Cons. Serv. Region 8, Albuquerque, N. Mex. 1938. Mimeogr.) noted also that *F. lowellii* is closely related to *F. anomala* and similar in fruits and general aspect but ranges farther south in Arizona, becoming larger and usually forming thickets.

*F. anomala* and *F. lowellii* are easily separated from other ashes of western United States except *F. dipetala* by their quadrangular twigs and broad flattened fruits with wing extending to base. Kearney and Peebles (Ferns Fl. Pl. Ariz. 671. 1942; Ariz. Fl. 641. 1951) in their key characterized the leaves of *F. anomala* as "1- or 3-foliolate, the single or terminal leaflet broadly ovate or orbicular, truncate or short-cuneate at base, commonly obtuse or retuse at apex, the margin entire to crenate" and the leaves of *F. lowellii* as "3-, 5-, or 7-foliolate; leaflets oblong-lanceolate, elliptic, or ovate, the terminal one usually obovate, cuneate at base, the margin commonly crenate-serrate."

*F. anomala* in its typical variation (var. *anomala*) is found in western Colorado, extreme northwestern New Mexico, northern Arizona, southern Utah, southern Nevada, and southeastern California. Though it is distinguished by its simple leaves, 2- or 3-foliolate leaves are occasionally found on specimens throughout its range. The isotype examined (*Newberry in 1859*, US) has one leaf with 2 leaflets among the otherwise simple leaves. Leaves with 5 leaflets, while rare, were noted on sheets from Utah, Nevada, and California. Leaflets of compound leaves, including the terminal leaflet, tend to be narrower than simple leaves, becoming ovate and acute.

*F. anomala* var. *triphylla* Jones (California Acad. Sci. Proc., ser. 2, 5: 707. 1895) was described with 3 leaflets, but the isotype examined (*M. E. Jones 5082w*, Pagumpa, Mohave County, Ariz., US) has both simple and 3-foliolate leaves. Rehder (Proc. Amer. Acad. Arts Sci. 53: 212. 1917) properly reduced this variety to synonymy,

while Sudworth (Check List Forest Trees U. S. 225. 1927) first suggested the relationship of this variety to *F. lowellii*.

Differences in number of leaflets generally are regarded as varietal rather than of specific rank. Simple-leaved variations occur in other species of *Fraxinus*. For example, Muller (Amer. Midl. Nat. 27: 488. 1942) reduced the simple-leaved *Fraxinus nummularis* Jones to a form, *F. greggii* f. *nummularis* (Jones) C. H. Mull., here changed to a variety. Simple leaves are found occasionally in *F. cuspidata* var. *macropetala* (Eastw.) Rehd. of northern Arizona also. *F. dipetala* Hook. & Arnott of California has in Lower California a similar variety with reduced leaflets, 3 or sometimes 1, *F. dipetala* var. *trifoliolata* Torr.

*F. anomala* and *F. lowellii* have similar leaf texture and intergrade both in number of leaflets and in their shape but have ranges mostly separate. A few specimens are intermediate and have been referred under both names. Thus, the reduction of *F. lowellii* to a geographical variety seems warranted. The more widespread, typical variety *F. anomala* var. *anomala* (including the synonym var. *triphylla*) with its reduced leaves and usually smaller size may have developed under more xeric conditions.

- Fraxinus caroliniana** Mill. CAROLINA ASH  
*Fraxinus caroliniana* Mill., Gar. Dict. ed. 8,  
*Fraxinus* no. 6. 1768.  
*Fraxinus platycarpa* Michx., Fl. Bor.-Amer. 2:  
 256. 1803.  
*Fraxinus pauciflora* Nutt., No. Amer. Sylva 3:  
 61, t. 100. 1849.  
*Fraxinus platycarpa* β. *pubescens* M. A. Curtis,  
 Amer. Journ. Sci. Arts, ser. 2, 7: 408. 1849.  
*Fraxinus platycarpa* γ. *oblanceolata* M. A. Curtis,  
 Amer. Journ. Sci. Arts, ser. 2, 7: 408. 1849.  
*Fraxinus cubensis* Griseb., Cat. Pl. Cub. 170.  
 1866.  
*Fraxinus platycarpa* var. *floridana* Wenzig, Bot.  
 Jahrb. 4: 185. 1883.  
*Fraxinus floridana* (Wenzig) Sarg., Silva North  
 Amer. 14: 39, t. 717. 1902.  
*Fraxinus caroliniana* var. β. *cubensis* (Griseb.)  
 Lingelsh., Bot. Jahrb. 40: 221. 1907.  
*Fraxinus hybrida* Lingelsh., Bot. Jahrb. 40: 220.  
 1907.  
*Fraxinus rehderiana* Lingelsh., Pflanzenreich 72  
 Heft (IV. 243, I & II): 42. 1920.  
*Fraxinus caroliniana* var. *rehderiana* (Lingelsh.)  
 Sarg., Journ. Arnold Arb. 2: 173. 1921.  
*Fraxinus caroliniana* var. *pubescens* (M. A. Cur-  
 ties) Fern., Rhodora 39: 442. 1937.  
*Fraxinus caroliniana* f. *pubescens* (M. A. Curtis)  
 Fern. & Schubert, Rhodora 50: 188. 1948.  
*Fraxinus caroliniana* var. *oblanceolata* (M. A.  
 Curtis) Fern. & Schubert, Rhodora 50: 188.  
 1948.

*Fraxinus caroliniana* var. *oblanceolata* f. *hypomalaca* Fern. & Schubert, *Rhodora* 50: 189. 1948.

*Fraxinus caroliniana* var. *cubensis* f. *lasiophylla* Fern. & Schubert, *Rhodora* 50: 189. 1948.

*Fraxinus pauciflora* Nutt. was accepted as a separate species by Small (Fl. Southeast. U. S. 918. 1903; Man. Southeast. Fl. 1039. 1933), by Sargent (Man. Trees North Amer. ed. 2, corr. 839. 1926) and other authors but has been reduced to synonymy by Fernald and Schubert (*Rhodora* 50: 188. 1948) and Rehder (Bibliog. Cult. Trees Shrubs 559. 1949). Earlier Sargent (*Silva North Amer.* 14: 39, t. 717. 1902) recognized this segregate as *F. floridana*.

Fernald and Schubert (*Rhodora* 50: 186-190. 1948) noted that *Fraxinus caroliniana* Mill., of the southern Coastal Plain and Cuba, is extremely variable and distinguished besides the typical variety two geographical varieties and three pubescent forms, one for each variety. The same treatment was followed by Fernald in Gray's Manual (ed. 8, 1149. 1950). These three varieties differ in shape of the samara, which is broadly oblong-ob lanceolate to rhombic or sub-elliptic in the typical variety, ob lanceolate in var. *oblanceolata*, and narrowly ob lanceolate in var. *cubensis*. If these minor variations in samara shape and pubescence merit names, similar variations could be named in several other species. No varieties are distinguished here.

#### *Fraxinus dipetala* Hook. & Arnott

TWO-PETAL ASH

*Fraxinus dipetala* Hook. & Arnott, Bot. Beechey Voy. 362, t. 87. [1838.]

Two-petal ash, also called California flowering ash, California shrub ash, and foothill ash, is to be accepted definitely as a tree species along with other usually shrubby species of southwestern United States, such as *F. anomala*, *F. cuspidata*, and *F. greggii*. Sargent (*Silva North Amer.* 6: 31, t. 261. 1894) admitted *F. dipetala* as the only American species not known to be arborescent and described it as a under-stemmed shrub 10 or 12 feet tall, possibly under favorable conditions a small tree. Afterward he omitted it from his Manual, mentioning it as the only native species not becoming a tree (Man. Trees North Amer. ed. 2, corr. 833. 1926). Britton and Shafer (*North Amer. Trees* 811. 1908) similarly described *F. dipetala* in small type without illustration as a shrub not definitely known to form a tree.

McMinn and Maino (Illus. Man. Pacific Coast Trees 337. 1935) and McMinn (Illus. Man. California Shrubs 436. 1939) included this species as a shrub or small tree 6 to 18 feet high. Jepson (Fl. California 3: 81. 1939) described *F. dipetala* as a shrub 5 to 15 (or 22) feet high, sometimes distinctly arborescent. He found individuals 22 feet tall and 4 inches in trunk diameter on the Arroyo Seco in Santa Lucia Mountains, Calif. Rehder (Man. Cult. Trees Shrubs 744. 1937; ed. 2, 770. 1940) recorded it as a shrub or small tree. Abrams (Illus. Fl. Pacific States 3: 347. 1951) mentioned it as a small tree or shrub 2 to 7 meters high.

Most collections do not have data on size. The Forest Service Herbarium has several specimens of *F. dipetala* collected by Forest Service field men and described on the labels as small trees up to 14, 15, 20, and 25 feet tall and 2 to 6 inches D. B. H. One sheet in the United States National Museum recorded the size as a small tree 15 to 30 feet.

#### *Fraxinus dipetala* var. *trifoliolata* Torr.

*Fraxinus dipetala* var. *trifoliolata* Torr., U. S. Mex. Bound. Surv. Bot. 167. 1859.

*Fraxinus schiedeana* var.  $\beta$ . *palmarum* Lingelsh. Pflanzenreich 72 Heft (IV. 243, I & II): 33. 1920; *ex parte*.

*Fraxinus jonesii* Lingelsh., Pflanzenreich 72 Heft (IV. 243, I & II): 35, fig. 9 G. 1920; *ex parte*.

*Fraxinus trifoliolata* (Torr.) Lewis & Epling, Amer. Midl. Nat. 24: 743, fig. 2. 1940; "*trifoliolata*," corrected by Gray Herbarium Card-index Issue 204.

This geographical variety in northwestern Lower California, Mexico, was originally described as "a shrub or small tree growing in clumps, sometimes 20 feet high, with a trunk three inches in diameter." Var. *trifoliolata* has been elevated to specific rank by Lewis and Epling (Amer. Midl. Nat. 24: 743-746, fig. 1, 2. 1940), who mentioned the following main differences besides geographical separation: fewer (3-1) entire or weakly serrate leaflets, the lateral smaller, and by the slightly larger petals and filaments forming a distinct tube.

Lingelsheim in 1920 based his two names cited above partly on *M. E. Jones 3740 ex parte*, the first of two collections or cotypes cited for each name. This number, collected by M. E. Jones at Valley of Palms, Lower California, April 8, 1882, was distributed under a printed label as *F. dipetala*. The two sheets of *M. E. Jones 3740* (US) examined are flowering specimens of var.

*trifoliolata*. Lingelsheim (p. 22) thought this variety which he did not know might be a species and unknowingly he based a new species and new variety partly upon specimens of this variety. *F. jonesii* was described from sterile material of *M. E. Jones 3740 ex parte* and *Pringle 137 ex parte* from Chihuahua. Rehder (Proc. Amer. Acad. Arts Sci. 53: 201. 1917) cited the sterile branches with pubescent leaves in the latter collection as apparently representing a juvenile form of *F. cuspidata* Torr. No sterile branches were found on the two sheets seen of *Pringle 137* (US). Lingelsheim's illustration (fig. 9 G) may have been from Pringle's specimen. It shows a pubescent leaf with slightly winged rachis and 5 leaflets. Standley (Trees Shrubs Mex. 1135. 1924) cited *F. jonesii* as a synonym of *F. attenuata* Jones, but the latter was based instead upon *M. E. Jones 3741* from the same locality, as mentioned below under *F. velutina*. If *F. dipetala* var. *trifoliolata* is accepted as a species, the name *F. jonesii* Lingelsh., honoring the collector of the first of the two sterile cotypes cited, is available.

***Fraxinus gooddingii* Little, sp. nov.**

GOODDING ASH

Sect. *Fraxinaster* DC., subsect. *Pauciflorae* Lingelsh. Frutex magna vel arbor parva 6 m alta, plerumque sempervirens. Ramuli juniores, gemmae, petioli, et paniculae dense tomentulosi pilis multiradiatis glandulosi fulvis; ramuli teretes, graciles, plerumque minus 2 mm diametro, demum glabrescentes et cinerei vel grisei; gemmae ovoideae, parvae, 1-4 mm longae. Folia 2.5-8 cm longa, petiolo et rachide supra canaliculatis, anguste alatis. Foliola 5-9, plerumque 7, parva, sessilia, elliptica vel anguste elliptica, 1-2.5 (0.7-3) cm longa, 0.5-1.5 cm lata, basi acuta, apice plerumque acuta vel obtusa, chartacea vel subcoriacea, venulis leviter reticulatis, margine plana vel subrecurva, ultra partem mediam crenulata vel serrulata vel interdum fere integra, supra fusco-viridia, leviter nitida, glabra vel paucis pilis minutibus peltatis, subtus pallidiora, dense punctata numerosis pilis minutibus peltatis, costa interdum puberula. Paniculae laterales, parvae, 1-4 cm longae, ante folias. Flores parvi, pedicellis gracilibus 2-4 mm longis; calyx campanulatus, parvus, 1 mm longus, scariosus, leviter 4-lobatus, externe puberulens pilis multiradiatis; corolla nulla; stamina 2, filamentis 2 mm longis et antheris 2 mm longis; pistillum 2 mm longum; ovarium ovoideum, compressum,

non calycem superans, 2-loculare; stylus exsertus; stigma 2-lobatum. Samara anguste oblanceolata, 12-20 mm longa, flavo-fusca, pars inferior (corpus) teres, 5-8 mm longa et 1.5 mm crassa, ala 3-4 mm lata, tenuis, submembranacea, fere basi decurrens, apice rotundata vel interdum emarginata, nervis non conspicuis, stylo raro persistentis.

Large shrub or small tree to 20 feet tall, usually evergreen. Young twigs, buds, petioles, and panicles densely tomentulose with multiradiate glandular, fulvous hairs; twigs terete, slender, mostly less than 2 mm in diameter, at length glabrescent and ash-colored or gray; buds ovoid, small, 1-4 mm long. Leaves 2.5-8 cm long; petiole and rachis grooved above, narrowly winged. Leaflets 5-9, usually 7, small, sessile, elliptical or narrowly elliptical, 1-2.5 (0.7-3) cm long, 0.5-1.3 cm broad, acute at base, usually acute or obtuse at apex, chartaceous or subcoriaceous, with veins slightly reticulate, margin flat or slightly recurved, crenulate or serrulate above middle or sometimes almost entire; above brownish green, slightly shiny, glabrous or with few minute peltate hairs; beneath paler, densely punctate with numerous minute peltate hairs, with costa sometimes puberulent. Panicles lateral, small, 1-4 cm long, before the leaves. Flowers small, on slender pedicels 2-4 mm long; calyx campanulate, small, 1 mm long, scariosus, shallowly 4-lobed, with multiradiate hairs on the outside; corolla none; stamens 2, with filaments 2 mm long and anthers 2 mm long; pistil 2 mm long; ovary ovoid, flattened, not exceeding the calyx, 2-celled; style exserted; stigma 2-lobed. Samara narrowly oblanceolate, 12-20 mm long, yellow brown, lower part (body) terete, 5-8 mm long and 1.5 mm thick, wing 3-4 mm broad, thin, submembranaceous, decurrent nearly to base, apex rounded or sometimes emarginate, nerves inconspicuous, style rarely persistent.

*Range*.—Santa Cruz County, Ariz., collected at two localities at an elevation of 3,600 to 5,000 feet on the Coronado National Forest about 10 and 16 miles west-northwest of Nogales and within 4 miles of the Mexican border. Also at an elevation of 4,000 feet in northeastern Sonora, Mexico, about 70 miles south of the southeastern corner of Arizona.

*Specimens examined*.—The specimens cited below kindly have been lent for study by four herbaria: United States National Museum (US), University of Arizona (Ariz.), Soil Conservation

Service, Tucson, Ariz. (SCS), and University of Michigan (Mich.). Two duplicates have been deposited in the Forest Service Herbarium (USFS). All the specimens except three were collected by Leslie N. Goodding. ARIZONA, Santa Cruz County: Peña Blanca, *Goodding* July 4, 1934 (SCS 1878), Sept. 6, 1934 (US, Ariz.), March 15, 1935 (US, USFS, Ariz., SCS 1875), May 2, 1935 (Ariz., SCS 1976), May 3, 1935 (Ariz., SCS 1877, 4751), May 15, 1935 (US, SCS 1879), spring 1935 (SCS 1880). Sycamore Canyon, *Goodding* May 15, 1934 (US, USFS, SCS 1874), May 15, 1936 (US 1634003 HOLOTYPE, 1699998); *Charles Proctor* Aug. 18, 1936 (SCS 3030). [Near] Nogales, *Thornber, Goodding, and Nelson 243*, March 16, 1935 (US, Ariz.). MEXICO, SONORA, Cañon del Temblor, 4,000 feet elevation; region of Río de Bavispe, northeastern Sonora, *Edwin A. Phillips 736*, Aug. 24, 1940 (Mich.).

*Remarks.*—*Fraxinus gooddingii* is named for Leslie Newton Goodding, who discovered this species in 1934, while employed as botanist by the Soil Conservation Service, U. S. Department of Agriculture, and who tested it in cultivation as an ornamental. I am indebted to him for specimens and notes. Goodding, who has done extensive field work with southwestern plants for many years, believes that this species in the United States is confined to Santa Cruz County. In a letter he explains that the specimens from Peña Blanca came from the north slope of a high butte a mile or so southwest of that place. Peña Blanca is a spring and concrete water tank in sec. 35, T. 23 S., R. 12 E., on the road between Nogales and Ruby, about 10 miles west-northwest of Nogales. Sycamore Canyon is in T. 23 S., R. 11 E., south of Ruby also about 16 miles west northwest of Nogales, and drains southward into Mexico. This species does not occur along the stream but up on the steep, dry, rocky slopes and ridges.

Goodding states that this species is a small tree, usually not more than 20 feet tall and frequently is shrubby. Two or three trees were grown in the Soil Conservation Service nursery at Tucson, where they were beautiful small ornamentals. Though normally evergreen, they shed their leaves in cold winters. According to the specimens, flowers are formed from March to early May and fruits mature in May. At least some of the flowers are perfect, and the species is not dioecious.

Under the name *Fraxinus greggii*, this ash has

been recorded from Arizona in a few botanical publications. Its occurrence in Arizona was unknown when the genus was monographed by Rehder (The genus *Fraxinus* in New Mexico and Arizona. Proc. Amer. Acad. Arts Sci. 53: 197–212: 1917). This species escaped notice by collectors of the two Mexican boundary surveys. After discovering it in Arizona in 1934, Goodding (Notes on native and exotic plants in Region 8, p. 120. Soil Conservation Service, Albuquerque, N. Mex. 1938. Mimeogr.) first recorded it as a small handsome tree or tall shrub which grows on very arid rocky slopes, not along streams, and which would be of use probably only as an ornamental. Kearney and Peebles (Fl. Pl. Ferns Ariz. 672. 1942; Ariz. Fl. 642. 1951) cited only Goodding's collection in 1936 and predicted: "Further study may show the Arizona form to be at least a good variety." They listed several differences of this collection from specimens of *F. greggii* from Texas and Mexico.

Benson and Darrow (Man. Southwest. Desert Trees Shrubs 260. 1945) mentioned *Fraxinus greggii* from Sycamore Canyon also. In my popular handbook (Southwestern Trees 99–100. fig. 1950), I cited only the Sycamore Canyon record from Arizona but illustrated a representative specimen of *F. greggii* from Chisos Mountains, Brewster County, Tex. (*Warnock 1078*, US). (The scale of the fruit was shown there incorrectly as  $\frac{1}{2} \times$  instead of  $1 \times$ .)

Any proposed new species of native trees in the United States naturally is subject to critical review because of the improbability that a tree species could have escaped detection and recognition so long by botanists in this well explored country. However, this small tree is from barely inside the United States on the edge of foreign territory botanically relatively unexplored. Sycamore Canyon on the Mexican border and draining into Mexico, has an unusual element of Mexican plants reaching their northernmost occurrence a few miles across the border in southern Arizona. In this rugged canyon within the Coronado National Forest many interesting plant species have been discovered including several rarities not found elsewhere in the United States, as related by Goodding (A hidden botanical garden, planted only by nature, Sycamore Canyon in southern Arizona yields species of plants from distant regions as well as numerous rarities, Journ. New York Bot. Gard. 47: 86–96, illus. 1946).

In a search for specimens from adjacent northern Mexico, a reference to *Fraxinus greggii* A. Gray was noted in the published flora of the region of Río de Bavispe in northeastern Sonora by Stephen S. White (Lloydia **11**: 289. 1948). One specimen cited was borrowed from the University of Michigan Herbarium and found to be *F. gooddingii*.

*Fraxinus gooddingii* is not a segregate representing a minor variation of an older known species but is a new discovery first doubtfully assigned from a few specimens to a related species occurring some hundreds of miles away. The several collections now assembled for study show flowers and fruits and the constancy and variation of the characters. Besides, this new species has been grown in cultivation.

According to the monograph of *Fraxinus* L. by A. Lingelsheim (Oleaceae-Oleoideae-Fraxineae. Pflanzenreich 72 Heft (IV 243, I. & II): 1-65, illus. 1920), the new species is placed in Sect. Fraxinaster, Subsect. Pauciflorae. This subsection comprised about five other species of xerophytic habit in Mexico and *F. greggii* also in western Texas, characterized by few-flowered inflorescences, winged rachises, small leaflets, and small fruits. *F. gooddingii* is related to *F. rufescens* Lingels., illustrated by Lingelsheim (fig. 9, C, D) and known only from the Mexican type (from Veracruz?), which has not been available for study. The latter differs in its ferruginous tomentose twigs, petioles, and panicles and in its smaller, usually entire, ovate leaflets.

*Fraxinus gooddingii* is distinguished from the closely related species *F. greggii* by the following characteristics: (1) twigs, buds, and petioles densely and minutely tomentose with multiradiate fulvous hairs, instead of young twigs slightly gray puberulent; (2) leaflets more numerous, 5-9, commonly 7, instead of 3-7 (or 1); (3) leaflets elliptical, broader and thinner, usually acute at apex, often slightly puberulent beneath, instead of oblanceolate narrow and coriaceous, obtuse at apex, glabrous except for the minute peltate hairs; (4) leaflet margin flat or slightly reflexed, crenulate or serrulate above middle, instead of reflexed, entire or crenulate; (5) wing of fruit decurrent nearly to base, instead of slightly decurrent at upper end.

From other species of the genus in Arizona, *Fraxinus gooddingii* is recognized by: (1) twigs slender, mostly less than 2 mm in diameter, fulvous tomentulose when young; (2) leaves ever-

green or nearly so, usually persistent until flowers appear in spring; (3) rachis narrowly winged; (4) leaflets small, only 1-2.5 cm long; (5) relatively small fruits only 12-20 mm long.

*Fraxinus greggii* A. Gray (Proc. Amer. Acad. Arts Sci. **12**: 63. 1876), Gregg ash, occurs in Trans-Pecos Texas and the Mexican states of Tamaulipas, Nuevo León, Coahuila, Chihuahua, and Zacatecas. *F. greggii* was discovered in 1847 in Nuevo León by Josiah Gregg but was first named *F. schiedeana* var. *parvifolia* Torr. (in Emory, U. S. Mex. Bound. Surv. Bot. 166. 1859) from specimens collected a few years later by botanists of the Mexican boundary survey. The following Mexican variety may be distinguished from the typical variation:

**Fraxinus greggii** A. Gray var. **nummularis** (Jones) Little, comb. nov.

*Fraxinus nummularis* Jones, Contrib. West. Bot. **12**: 59. 1908.

*Fraxinus greggii* A. Gray f. *nummularis* (Jones) C. H. Muller, Amer. Midl. Nat. **27**: 488. 1942.

Standley (Trees Shrubs Mex. 1135. 1924) suggested that *F. nummularis* Jones, which has simple leaves, probably was a form of *F. greggii*. Muller reduced the former to a form after studying a series of intermediate specimens with simple leaves and 3-, 5-, and 7-foliolate leaves from Chisos Mountains in western (Trans-Pecos) Texas (Torrey **34**: 40. 1934). For a consistent treatment, this xeric geographical variation with simple oval, coin-shaped leaves is here made a variety of the species typically with 3 to 7 oblanceolate leaflets. Var. *nummularis* in its extreme variation is not found in the United States but occurs in Coahuila, Mexico, where the type came from Sierra Mojada Mountains (M. E. Jones April 19, 1892, US), the center of this extreme variation. The intermediate plants of western Texas, which have much the aspect of the typical variation, may be referred to var. *greggii*.

**Fraxinus latifolia** Bentham OREGON ASH  
*Fraxinus pubescens* β. Hooker, Fl. Bor.-Amer. **2**: 51. [1838.]

*Fraxinus latifolia* Bentham, Bot. Voy. Sulphur **33**. 1844.

*Fraxinus oregona* Nutt., North Amer. Sylva **3**: 59, t. 99. 1849.

*Fraxinus oregona* β. *riparia* Nutt., North Amer. Sylva **3**: 59, t. 99c. 1849.

*Fraxinus oregona* var. α. *latifolia* (Bentham) Lingels., Bot. Jahrb. **40**: 220. 1907.

Recently Abrams (Illus. Fl. Pacific States 3: 346, fig. 3778. 1951) has adopted the older name *Fraxinus latifolia* Benthham for the species universally known as *F. oregona* Nutt. As Abrams made no explanation and as I had independently detected this older name, my notes on the nomenclature are summarized here.

When I first checked these names about 10 years ago, I noted that *F. latifolia* Benthham would be the correct name for Oregon ash unless an earlier homonym could be found. After verifying the nomenclature later I delayed action in the hope that the International Rules would be amended in 1950 to prevent replacement of an established name by an older one not in use. As proposals to conserve specific epithets were decisively defeated at the Stockholm Congress in 1950 and as Abrams has already taken up *F. latifolia*, there is no need to postpone this name change any longer. *Fraxinus latifolia* Benthham was not an obscurely published name in an overlooked rare book but was properly published for an ash collected at San Francisco with full Latin diagnosis by a recognized authority in a botanical work well known to contemporaries and later taxonomists.

Torrey (U. S. Rpts. Explor. Surv. Miss. Pacif. 4: 128. 1857) united the two names under *F. oregona* Nutt. but cited Benthham's name as *F. grandifolia*. The spelling *F. oregana* and synonym *F. grandifolia* were used by Gray (in Wheeler & Wats., Bot. California ed. 2, 1: 472. 1880). Later, Gray (Synopt. Fl. North Amer. ed. 2, 2(1): 76. 1886) retained the spelling *F. oregana* but corrected the synonym to *F. latifolia*.

Modern usage of *Fraxinus oregona* Nutt. for this species perhaps was established by Sargent (Silva North Amer. 6: 57. 1894), who cited as a synonym the earlier name *F. latifolia* Benthham, "(not Willdenow)." I have searched in vain for an earlier homonym of *F. latifolia* Benthham by Willdenow or any other author. Index Kewensis and Supplementa listed none, nor did the monograph by Lingelsheim (Pflanzenreich 72 Heft (IV. 243, I & II). 1920). Rehder (Bibliog. Cult. Trees Shrubs 559. 1949) likewise had none while citing with dates the older name *F. latifolia* (1844) as a synonym of *F. oregona* (1849). Munz and Lauder milk (Aliso 2: 49-62, illus. 1949) in a taxonomic study of this species accepted the name *Fraxinus oregona* Nutt. without mention of *F. latifolia* Benthham.

Willdenow did use the epithet *latifolia* irregu-

larly for two varieties: *Fraxinus carolinana* . . .  $\beta$ . *F. latifolia* Willd., L., Sp. Pl. ed. 4, 4: 1103. 1805 [1806] and *Fraxinus pubescens* . . .  $\gamma$ . *F. latifolia* Willd., L. Sp. Pl. ed. 4, 4: 1104. 1805 [1806]. These unnumbered names designated by Greek letters clearly were not species or binomials and were not considered as such by later authors. They are not of the same rank as *F. latifolia* Benthham and therefore not earlier homonyms (art. 61). Both these varieties are now referred to *F. pennsylvanica* Marsh. The latter varietal name had been published earlier as *F. pubescens*  $\gamma$ . *latifolia* Vahl (Enum. Pl. 1: 52. 1804). The same varietal epithet was used by other authors under two additional species in this genus. Apparently Sargent rejected *F. latifolia* Benthham under an old "American Code" rule against use of the same varietal or specific epithet a second time within a genus, as he cited the trinomial *Fraxinus carolinana*  $\beta$  *latifolia* Willd. (Silva North Amer. 6: 50. 1894).

Lingelsheim (Pflanzenreich 72 Heft (IV. 243, I & II): 42. 1920) placed *F. latifolia* Benthham as a variety of *F. oregona* Nutt. Apparently he believed Nuttall's name had priority, dating it as 1842-44. Though the first volume of Nuttall's Sylva was issued in 1842-43 and the second in 1844, the third was not published until 1849.

As no varieties of this species are now recognized, varietal names made under *F. oregona* need not be transferred to *F. latifolia*. *F. oregona* var. *riparia* Nutt., with lanceolate samaras and serrate leaflets, scarcely merits recognition. Some variation in shape of fruits occurs in the specimens examined.

*Fraxinus oregona* var. *glabra* Lingelsheim. (Bot. Jahrb. 40: 220. 1907; nom. nud. Lingelsheim. ex Rehd., Proc. Amer. Acad. Arts Sci. 53: 207. 1917. Lingelsheim., Pflanzenreich 72 Heft (IV. 243, I & II): 43. 1920) has been accepted by some authors as a glabrous variety of southern California. However, Munz and Lauder milk (Aliso 2: 49-62, illus. 1949) suppressed this variety as a synonym of *F. velutina* var. *coriacea* (S. Wats.) Rehd. Abrams (Illus. Fl. Pacific States 3: 347. 1951) noted also that California plants of the latter were not quite typical and had been described as *F. oregona* var. *glabra* Lingelsheim.

**Fraxinus papillosa** Lingelsheim. ASH  
*Fraxinus papillosa* Lingelsheim., Bot. Jahrb. 40: 219. 1907.

Lingelsheim (Pflanzenreich 72 Heft (IV. 243, I & II): 38, fig. 10A. 1920) knew this species



apparently from just the type collection, *C. H. T. Townsend & C. M. Barber 354* (two isotypes seen at US), from Sierra Madre in western Chihuahua, Mexico. He placed this species next to *F. americana*, as both species had the leaflets papillose and glaucous beneath, but separated the former by its lax, few-flowered panicle and sessile leaflets. *F. texensis* (A. Gray) Sarg. was included there under *F. americana* var. *albicans* (Buckley) Lingelsh.

Rehder (Proc. Amer. Acad. Arts Sci. **53**: 210-211. 1917), in his monograph of Fraxinus in New Mexico and Arizona cited two additional collections. One of these, *E. A. Mearns 2533* (US) from San Luis Mountains, Hidalgo County, near the southwestern corner of New Mexico just across the international boundary, extended the range to the United States. He noted that this species differed from his then new species *F. standleyi* chiefly in the glaucous papillose under surface of the leaflets and from *F. americana* in its sessile smaller leaflets. Two other specimens cited by Rehder under *F. standleyi* are here referred to *F. papillosa*.

Sargent (Man. Trees North Amer. ed. 2, 840. 1922) in a note under *F. standleyi* mentioned the New Mexico record of *F. papillosa* as "a single plant, possibly a shrub." Subworth (Check List Forest Trees U. S. 295 pp. 1927) omitted this species. Standley (Trees Shrubs Mex. 1136. 1924) suggested that *F. standleyi* Rehder, *F. papillosa* Lingelsh., and *F. pringlei* Lingelsh., probably would have to be united ultimately. *F. papillosa* was not listed for Arizona by Kearney and Peebles (Fl. Pl. Ferns Ariz. 672. 1942; Ariz. Fl. 642. 1951) or by Little (Southwestern Trees 100. 1950).

Further study reveals six additional collections (three by U. S. Forest Service personnel on the Coronado National Forest) from different localities in the United States, extends the range to southeastern Arizona and northeastern Sonora, and confirms the tree size (from a forester's label) as 22 feet high and 12 inches D. B. H. These collections in the U. S. National Museum, Forest Service Herbarium, and University of Michigan Herbarium had been referred, with one exception, to *F. velutina* (or *F. standleyi*), which is common in the same region. The range of *F. papillosa* includes mountains of southwestern New Mexico and southeastern Arizona, northeastern Sonora, and Sierra Madre of western Chihuahua. Labels record an altitudinal distribution from 5,200 to 7,700 feet.

As its specific epithet indicates, *F. papillosa* is characterized by the papillose, glaucous or whitish under surface of the leaflets. This feature, which has been mentioned under *F. americana*, is found also in *F. texensis* and suggests a relationship with those species in addition to the similarity with *F. velutina* (or *F. standleyi*). These minute papillae, though not shown by a hand lens, are revealed by a high power (40 $\times$ ) dissecting microscope or by low power (50 $\times$  to 100 $\times$ ) of a compound microscope through direct examination of leaves or collodion leaf peels. Under high magnification the lower surface appears as a solid mass of whitish beads or sleetlike particles, the minute opaque papillae of each epidermal cell. The lower surface is without hairs except along the midrib and sometimes also larger veins. In *F. velutina* the greenish lower surface varies from hairy to glabrous and also may bear many minute peltate scales (characteristic of the family Oleaceae) and often numerous irregular or scurfy papillae not in a solid sleetlike mass. Specimens of *F. papillosa* generally can be recognized by the whitish, mostly glabrous under surface of the leaflets.

*F. papillosa* is closely related to *F. texensis* of Texas and Oklahoma but has somewhat smaller, sometimes elliptical, sessile (except in one specimen) leaflets with inconspicuous teeth or nearly entire. The small samaras of both are of the *F. americana* type, with broad terete body and longer wing usually only slightly decurrent.

The range of *F. americana* extends from northeastern United States into eastern Texas. Its xeric relative, *F. texensis*, is found in central Texas, including Edwards Plateau southwest to Devils River near the Mexican boundary. E. J. Palmer (Journ. Arnold Arb. **10**: 42. 1929) reported this species as the commonest ash in Davis Mountains, Jeff Davis County, in Trans-Pecos, Texas. He also extended the range to Arbuckle Mountains, Murray County, in southern Oklahoma. Milton Hopkins (Rhodora **45**: 274-275. 1943) recorded it also from Cherokee County in the northeastern part of Oklahoma.

The known range of the more xeric southwestern representative, *Fraxinus papillosa*, in mountains of western Chihuahua and northeastern Sonora and extending less than 30 miles north of the Mexican boundary into 4 counties of New Mexico and Arizona is somewhat separated. As *F. papillosa* hitherto has been unrecorded from Arizona, examination of herbarium specimens

and field searches may reveal additional localities and a more extensive distribution. A first record from Sonora was discovered in a loan of specimens of *Fraxinus* collected and cited by Stephen S. White (Lloydia 11: 289. 1948) in his flora of the region of Río de Bavispe.

The 10 collections of *F. papillosa* examined by me are cited below: MEXICO, CHIHUAHUA, Sierra Madre near Colonia García, C. H. T. Townsend & C. M. Barber 354, Sept. 29, 1899 (type collection, 2 sheets in US); E. slope of Sierra Madre between San Mateo and Guasarachi, E. A. Goldman 153, Sept. 24, 1898 (US). SONORA, Puerto de los Aserraderos, region of Río de Bavispe, northeastern Sonora, S. S. White Aug. 4-9, 1940 (Mich.). NEW MEXICO, Luna County, Florida Mountains, E. A. Goldman 1482, Sept. 8, 1908 (US); Hidalgo County, west side San Luis Mountains, E. A. Mearns 2533, Oct. 2, 1893 (US). ARIZONA, Cochise County, Jack Wood Canyon, Chiricahua Mountains, Coronado National Forest, H. D. Burrall 2083, Aug. 1907 (22 feet high, 12 inches D. B. H.; US); Cave Creek Public Camp, Chiricahua Mountains, Coronado National Forest, Roxana S. Ferris 9975 (Mich.; distributed as *F. papillosa*); Bear Cave, Huachuca Mountains, Coronado National Forest, Robert Thompson 76, July 1, 1928 (USFS 58857); Miller Canyon, Huachuca Mountains, Coronado National Forest, Robert Thompson 78, July 1, 1928 (USFS 58858). Santa Cruz (?) Co., Santa Ritz Mountains, Coronado National Forest, D. Griffiths & J. J. Thornber 176, Sept. 20 to Oct. 4, 1902 (US).

**Fraxinus pennsylvanica** Marsh. GREEN ASH

*Fraxinus pennsylvanica* Marsh., Arbustr. Amer. 51. 1785.

*Fraxinus lanceolata* Borkh., Theor.-Prakt. Handb. Fortsbot. 1: 826. 1800.

*Fraxinus juglandifolia* β. *subintegerrima* Vahl, Enum. Pl. 1: 50. 1804.

*Fraxinus viridis* Michx. f., Hist. Arb. Forest. Amér. Sept. 3: 115, t. 10. 1813; non Bosc (1809).

*Fraxinus pennsylvanica* var. *lanceolata* (Borkh.) Sarg., Silva North Amer. 6: 50, t. 272. 1894.

*Fraxinus darlingtonii* Britton, Man. Fl. North States Canada 725. 1901.

*Fraxinus campestris* Britton in Britton & Shafer, North Amer. Trees 799, fig. 726. 1908.

*Fraxinus smallii* Britton in Britton & Shafer, North Amer. Trees 805, fig. 735. 1908.

*Fraxinus pennsylvanica* var. *typica* Fern., Rhodora 40: 453, t. 529, fig. 3, 4. 1938.

*Fraxinus pennsylvanica* var. *austini* Fern., Rhodora 40: 452, t. 529, fig. 1, 2. 1938.

*Fraxinus pennsylvanica campestris* (Britton) F. C. Gates, Trans. Kansas Acad. Sci. 41: 102. 1938; 42: 137. 1939.

*Fraxinus pennsylvanica* var. *subintegerrima* (Vahl) Fern., Rhodora 49: 159. 1947.

It seems unnecessary to maintain green ash and red ash as botanically distinct varieties. The typical variety of *Fraxinus pennsylvanica* has been associated with the pubescent variation known as red ash. Green ash has been regarded as a glabrous variety (or species) of broader and especially more western range under the name *F. pennsylvanica* var. *lanceolata*. That combination was made by Sargent under an old "American Code" rule by which the oldest epithet, whether specific or varietal, was to be taken up. Sargent (Silva North Amer. 6: 51. 1894; Man. Trees North Amer. ed. 2, corr. 845-847, fig. 749, 750. 1926) noted the occurrence of many intermediate forms and that flowers and fruits of the two variations were indistinguishable. After mentioning the older names before (Rhodora 40: 453. 1938), Fernald in 1947 took up the oldest varietal epithet, which Sargent had cited in synonymy.

Jonathan W. Wright (Journ. Forestry 42: 591-597. 1944) in progeny tests obtained small percentages of pubescent seedlings from both the pubescent typical variety and the glabrous var. *lanceolata*, indicating that pubescence, the only character by which the two may be separated, is not true breeding. Thus, the glabrous variety should be reduced to synonymy. He noted three or more ecotypes in this species. As the glabrous variation known as green ash is commoner and more widespread than the pubescent typical variation known as red ash, the common name green ash is adopted here for the species without recognized botanical varieties.

Fernald (Rhodora 40: 450-454, illus. 1938; Gray's Man. ed. 8, 1148-1149, illus. 1950) distinguished a third variation of this species which passes into the other two, var. *austini* Fern. This intermediate variation within the same range, characterized by the pubescence of the typical variety and the toothed leaflets and shorter samaras of var. *subintegerrima* likewise scarcely merits recognition.

Three specific names by Britton cited above have previously been united with this species by other authors. Meuli (Proc. Minnesota Acad. Sci. 4: 38-42, illus. 1936) and Meuli and Shirley (Journ. Forestry 35: 1060-1062, illus. 1937), of the United States Forest Service, in testing

drought resistance of green ash seedlings from seeds collected in seven States placed *F. campestris* Britton with *F. pennsylvanica* var. *lanceolata*.

**Fraxinus profunda** (Bush) Bush PUMPKIN ASH  
*Fraxinus americana profunda* Bush, Missouri Bot. Gard. Ann. Rpt. 5: 147. 1894.

*Fraxinus pennsylvanica profunda* (Bush) Sudw., U. S. Dept. Agr. Div. Forestry Bull. 14: 329. 1897.

*Fraxinus profunda* (Bush) Bush, Gard. & Forest 10: 515. 1897.

*Fraxinus michauxii* Britton, Man. Fl. North. States Canada. ed. 2, 1075. 1905.

*Fraxinus profunda* var. *ashei* E. J. Palmer, Journ. Arnold Arb. 13: 417. 1932.

Pumpkin ash, *Fraxinus profunda* (Bush) Bush, has been widely accepted as a species since its recognition by Britton (Man. Fl. North. States Canada 725. 1901) and Sargent (Silva North Amer. 14: 35-36, t. 714, 715 1902). Jonathan W. Wright informs me that it is a polyploid (6 n).

Fernald (Rhodora 40: 452, t. 528. 1938) took up *Fraxinus tomentosa* Michx. f. (Hist. Arbr. Forest. Amér. Sept. 3: 112, t. 9. 1813) for this species and assigned *F. michauxii* Britton to synonymy, after listing *F. profunda* the year before (Rhodora 39: 331, 442, 1937). Use of *F. tomentosa* by Fernald in the new Gray's Manual (ed. 8: 1148, fig. 1396. 1950) may result in widespread acceptance of this name.

Unfortunately, *F. tomentosa* Michx. f. must be rejected as nomenclaturally superfluous when published (art. 60) because *Fraxinus pubescens* Lam. was cited in synonymy. Thus, *F. tomentosa* with similar meaning was indicated by its author to be a renaming of *F. pubescens*. In Index Kewensis *F. tomentosa* is a synonym of *F. pubescens*. F. A. Michaux similarly changed several other names without justification in the same work. I shall discuss these in another article.

Britton in proposing the new name *F. michauxii* explained that it was *F. tomentosa* Michx. as to plate but not description, which applied to *F. pennsylvanica*. Later Britton in Britton & Shafer (North Amer. Trees 804. 1908) noted that Michaux cited *Fraxinus pubescens* Lamarck "(which is the same as *F. pennsylvanica* Marshall)" as a synonym. Fernald, in quoting a portion of Britton's statement while reducing *F. michauxii* to synonymy, omitted Britton's significant remarks about Michaux's synonymy.

*Fraxinus pubescens* Lam. (Encycl. Méth. Bot. 2: 548. [1788]) is generally regarded as a synonym

of *F. pennsylvanica* Marsh. The type of *F. pubescens* Lam., according to a photograph kindly lent by the Gray Herbarium, apparently is as identified but has no fruits. *F. pubescens* Walt. (Fl. Carol. 254. 1788) appeared the same year and is the same, according to Sargent (Silva No. Amer. 6: 49. 1894).

**Fraxinus velutina** Torr. VELVET ASH  
*Fraxinus velutina* Torr. in Emory, Notes Mil. Recon. Ft. Leav. Calif. 149. 1848.

*Fraxinus pistaciaefolia* Torr., U. S. Rpts. Explor. Surv. Miss. Pacif. 4: 128. 1857.

*Fraxinus coriacea* S. Wats., Amer. Nat. 7: 302. 1873

*Fraxinus pistaciaefolia* var. *coriacea* (Torr.) A. Gray, Synopt. Fl. North Amer. 2 (1): 74. 1878.

*Fraxinus americana* var. *pistaciaefolia* (Torr.) Wenzig, Bot. Jahrb. 4: 182. 1883.

*Fraxinus papillosa* Lingelsh., Bot. Jahrb. 40: 219. 1907.

*Fraxinus oregona* var.  $\beta$ . *glabra* Lingelsh., Bot. Jahrb. 40: 220. 1907; *nom. nud.* Lingelsh., Pflanzenreich 72 Heft (IV. 243, I & II): 43. 1920.

*Fraxinus attenuata* Jones, Contrib. West. Bot. 12: 59. 1908 (March 26).

*Fraxinus toumeyi* Britton in Britton & Shafer, North Amer. Trees 803, fig. 732. 1908 (April).

*Fraxinus oregona* var. *glabra* Lingelsh. ex Rehd., Proc. Amer. Acad. Arts Sci. 53: 207. 1917.

*Fraxinus glabra* Thornber ex Rehd., Proc. Amer. Acad. Arts Sci. 53: 207. 1917; *pro syn.* Thornber ex Gray Herbarium Card-index Issue 77. Thornber ex Tidestrom & Kittell, Fl. Ariz. N. Mex. 516. 1941.

*Fraxinus standleyi* Rehd., Proc. Amer. Acad. Arts Sci. 53: 208. 1917.

*Fraxinus standleyi* var. *lasia* Rehd., Proc. Amer. Acad. Arts Sci. 53: 210. 1917.

*Fraxinus velutina* var. *coriacea* (S. Wats.) Rehd., Proc. Amer. Acad. Arts Sci. 53: 206. 1917.

*Fraxinus velutina* var. *glabra* Rehd., Proc. Amer. Acad. Arts Sci. 53: 207. 1917.

*Fraxinus velutina* var. *toumeyi* (Britton) Rehd., Proc. Amer. Acad. Arts Sci. 53: 204. 1917.

*Fraxinus velutina* var.  $\alpha$ . *typica* Lingelsh., Pflanzenreich 72 Heft (IV. 243, I & II): 43. 1920.

*Fraxinus velutina* var.  $\gamma$ . *glabrata* Lingelsh., Pflanzenreich 72 Heft (IV. 243, I & II): 43. 1920; *ex parte*.

Variations in pubescence within this species have resulted in several names. Soon after describing the tomentose form as *F. velutina*, Torrey saw additional specimens and deliberately changed the name to *F. pistaciaefolia*. He explained that the species was excessively variable in its foliage and was so much more generally smooth than pubescent or velvety. Sudworth

(U. S. Dept. Agr. Rpt. 1892: 326. 1893) restored the older name *F. velutina* and reduced *F. coriacea* to synonymy. The isotype examined of *F. pistaciaefolia* Torr. (US 49948) is a mixture. It was collected by J. M. Bigelow and bears a printed label with locality, "California." The original description published the following collection data: "Rocky ravines of Williams' River [probably near Williams, Arizona]; January 3 [1854]: fruit only." This specimen consists of four leafless winter twigs of *F. cuspidata* var. *macropetala*, of which one has one attached fruit and two have old panicles without fruits. One of the latter has also two glabrous fruiting panicles of *F. velutina* bearing many small fruits, but the two panicles are not joined to the twig but merely glued to the sheet in natural, opposite arrangement at the same node. In the pocket are two broad fruits of *F. cuspidata* var. *macropetala* and many fruits of *F. velutina*. Fortunately, *F. pistaciaefolia* Torr. is rejected as nomenclatorially superfluous (Art. 60) and thus cannot be adopted for the main element of the mixture (Art. 64, emend. 1950) as an older name to replace *F. cuspidata* Torr. (in Emory, U. S. Mex. Bound. Surv. Bot. 166. 1859) and *F. macropetala* Eastw. (Bull. Torrey Bot. Club 30: 494. 1903). Bigelow's specimen apparently is the oldest collection of *F. cuspidata* var. *macropetala* (Eastw.) Rehd.

Alfred Rehder (The genus *Fraxinus* in New Mexico and Arizona, Proc. Amer. Acad. Arts Sci. 53: 199-212. 1917) also recognized the great variability of southwestern ashes, noting extreme forms connected by intermediates and glabrous and pubescent forms growing mostly side by side. However, as cited above, he proposed one new species and two new varieties while reducing *F. coriacea* and *F. toumeyii* to varieties.

Kearney and Peebles (Ferns Fl. Pl. Ariz. 672. 1942; Ariz. Fl. 642. 1951) suppressed *F. standleyi* but maintained var. *toumeyii* with distinctly stalked leaflets and var. *glabra* with glabrous leaves and twigs and noted that Arizona material of the latter occasionally approached var. *coriacea*. Benson and Darrow (Man. Southwest. Trees Shrubs 259-260, 377, t. 85, 86. 1945) accepted *Fraxinus velutina* without varieties, including *F. coriacea* and *F. attenuata* as well as *F.*

*oregona* var. *glabra* in the synonymy. I agree with Benson and Darrow's reductions.

*Fraxinus attenuata* Jones was based upon two specimens, *M. E. Jones 3741*, Valley of Palms, Lower California, Mex. (US), and *Thornber* June 15, 1903, Catalina Mountains, Ariz. (US), both variations of *F. velutina*. The former specimen was also a cotype (the first specimen cited) of *F. velutina* var. *glabrata* Lingelsh., which was based upon *F. berlandieriana* Schellenberg (Repert. Spec. Nov. Regni Veg. 12: 239. 1913), *nom. nud.*, non DC., and which represents in part the variation with narrow, long-stalked, coriaceous leaflets.

*Fraxinus coriacea* S. Wats. was described from two specimens, *G. M. Wheeler in 1871*, "Ash Meadows," Nev. (designated by Rehder as the type; not seen) and Bigelow, "Devil's Run Canyon, Arizona" [western Tex.], the latter referred by Rehder to *F. texensis* (A. Gray) Sarg. This xeric variation with coriaceous, more reticulate leaflets occurs in southwestern Utah, southern Nevada, southeastern California, and northern Lower California, with transitions in Arizona. The coriaceous, slender-stalked, often coarsely serrate leaflets vary in shape from elliptic and obtuse in the type to rhombic-lanceolate and attenuate southward (*F. attenuata* Jones, *Jones 3741*; US). Some of the material from southern California is not coriaceous and was cited by Rehder as *F. oregona* var. *glabra*, for example *Purpus 5555* (cotype and first specimen cited, US).

Philip A. Munz and J. D. Laudermilk (A neglected character in western ashes (*Fraxinus*), *El Aliso* 2: 49-62, illus. 1949) referred the southern California ashes to var. *coriacea*, maintained as a northern and western geographic variety, with *F. oregona* var. *glabra* as a synonym. They excluded typical *F. velutina* from California. However, Jepson (Fl. Calif. 3: 80. 1939) and Abrams (Illus. Fl. Pacif. States 3: 347, fig. 3779. 1951) accepted both typical *F. velutina* and var. *coriacea* for southern California. On the basis of one plant examined, Herbert Taylor (Cyto-taxonomy and phylogeny of the Oleaceae, *Brittonia* 5: 337-367, illus. 1945) reported var. *coriacea* to be a tetraploid.

Jonathan W. Wright informs me that *F. velutina* crosses readily with *F. pennsylvanica* and is closely related to the latter.

PALEONTOLOGY.—*Taxonomic notes on genera of fossil and Recent Bryozoa.*R. S. BASSLER,<sup>1</sup> U. S. National Museum.

Since the publication of an article *Generic descriptions of Upper Paleozoic Bryozoa* in this JOURNAL in 1941,<sup>2</sup> the writer has had occasion to check the nomenclature of this phylum in some detail while bringing his working generic catalogue up to date and rearranging the bryozoan study collection in the U. S. National Museum. As a result, a number of new genera as well as other necessary changes came to light, some of which had been recognized as long ago as 1900 when the late John M. Nickles and the writer published their *Synopsis of American fossil Bryozoa*.<sup>3</sup> As these new genera are concerned in the preparation of the bryozoan chapter for the *Treatise on invertebrate paleontology*, which will not include descriptions of new genera and species, it is necessary to validate their names in advance. The following changes in taxonomy include a number of new names proposed in honor of bryozoan specialists who have contributed much to the science. As the complete citations to the described type species are given in several of the standard bibliographic works on Bryozoa, only the page, plate, and figure are quoted herewith.

## Order CTENOSTOMATA Busk, 1852

## Family Vinellidae Ulrich and Bassler, 1904

**Condranema**, n. name to replace *Heteronema* Ulrich and Bassler, 1904, not Dujardin, 1841. Type species: *Heteronema capillare* Ulrich and Bassler, 1904, p. 278, pl. 65, fig. 11. Silurian of Gotland.

**Marcusodictyon**, n. gen. Like *Condranema*, but the threads (stolons) unite to form usually 6-sided polygons. Type species: *Heteronema priscum* Bassler, 1911, p. 58, figs. 6a-d. Lowest Ordovician; Esthonia.

## Family Ascodictyonidae Ulrich, 1890

**Eliasopora**, n. gen. Like *Ascodictyon*, but vesicles are oval and radiately arranged in clusters, which are connected at intervals by stolons. Type species: *Ascodictyon stellatum* Nicholson and Etheridge, 1877, p. 464, pl. 19, figs. 1-6 Middle Devonian; western New York.

<sup>1</sup> Published by permission of the Secretary, Smithsonian Institution.

<sup>2</sup> BASSLER, R. S., JOURN. WASHINGTON ACAD. SCI. 31 (5): 173-179, figs. 1-24. 1941.

<sup>3</sup> NICKLES, J. M., and BASSLER, R. S., U. S. GEOL. SURV. BULL. 173: 1-663. 1900.

## Order CYCLOSTOMATA Busk, 1852

## Family Diastoporidae Gregory, 1899

**Flabellotrypa**, n. gen. Like *Sagenella*, but zooecia open only along outer edge of the incrusting flabelliform zoarium. More or less circular attached disks about 3.5 mm wide, of parallel, contiguous, transversely striated tubes. Type species: *F. rugulosa*, n. sp. Helderbergian (Linden); near Chaseville, Benton County, western Tennessee. Holotype: U.S.N.M. no. 116416. [Fig. 1, × 10.]

**Mitoclemella**, n. gen. Like *Mitoclema*, but apertures project upward in rapidly ascending spirals. Type species: *Mitoclema mundulum* Ulrich, 1890, p. 177, figs. 4a, b, c, Trentonian (Nematopora bed); Cannon Falls, Minn. Cotypes: U.S.N.M. no. 43297.

**Osburnostylus**, n. gen. Like *Mitoclema*, but zoarium of minute, jointed segments. Type species: *O. articulatus*, n. sp. Individual segments about 4 mm long with usually six parallel encircling rows of apertures and both ends pointed for attachment. Ordovician-Blackriveran (Benbolt); near Rye Cove, Va. Holotype: U.S.N.M. no. 116418 (Fig. 2a), paratype (Fig. 2b).

**Voigtopora**, n. gen. Like *Stomatopora*, but the individual zooecia are broad, elliptical, slightly constricted at their base, and marked by parallel transverse lines. Type species: *Alecto calypso* d'Orbigny, 1852, p. 844, pl. 630, figs. 5-8. Cretaceous (Senonian) of France.

## Semiceidae, n. name

**Semiceidae**, n. name (based on *Semicea* d'Orbigny 1854). Proposed to replace *Ceidae* d'Orbigny, 1852, which was named after *Cea* d'Orbigny, 1854, preoccupied by Walker, 1837. Family of Cretaceous cyclostomatous Bryozoa.

## Family Fistuliporidae Ulrich, 1882

**Duncanoclema**, n. gen. Solid twiglike fragments with internal structure of *Fistulipora* except that the lunaria are pierced by 6-8 hollow tubes or pores similar to those in *Anolotichia* of the Ceramoporidae. Type species: *Fistuliporella marylandica* Ulrich and Bassler, 1913, p. 266, pl. 45, figs. 8-11. Silurian (Keyser); western Maryland.

**Xenotrypa**, n. gen. A small solid dome-shaped mass of rounded untabulated zooecia with indistinctly developed lunaria, separated by typical vesicular interzooecial spaces traversed by large, thick, dense, granulose acanthopore-like tubes. Type species: *Fistulipora primavea*

Bassler, 1911, p. 109, text fig. 40. Ordovician (Glauconite ls.); Government of St. Petersburg, Russia.

Hexagonellidae, n. fam.

**Hexagonellidae**, n. fam. Proposed for the reception of Hexagonellinae Crockford, 1947, subfamily of Fistuliporidae Ulrich, 1882. Ten genera with the special characters of the subfamily are already known, so that its elevation to family rank seems not unreasonable.

Order TREPOSTOMATA Ulrich, 1882

Family Monticuliporidae Nicholson, 1881

**Prasoporina**, n. gen. Like *Prasopora*, but cystiphragms isolated, semiglobular structures connected with opposite wall by a few diaphragms. Type species: *Prasopora (Monticulipora) selwynii* Nicholson, 1881, p. 206, fig. 44; Ulrich 1893, p. 250, pl. 16, figs. 16, 17.

Family Batostomellidae Ulrich, 1890

**Canutrypa**, n. gen. Ramose, with thick polygonal amalgamated zoecial walls in mature zone separated by a row of tabulated mesopores and lined in most cases by large, sometimes spherical, cystiphragms suggesting ovicells. Type species: *C. francqana*, n. sp. Upper Devonian; Ferques, France. Holotype: U.S.N.M. no. 116417. [Figs. 3, 4, tangential and vertical thin sections.]

Family Stenoporidae Duncan, 1939

**Lioporidra**, n. name for *Liopora* Girty, 1915, not Nicholson and Etheridge, 1878. Thin layers of zoecia with numerous mesopores, no diaphragms but spinelike projections from the walls. Type species: *Liopora subnodosa* Girty, 1915, p. 341, pl. 38, figs. 2, 2a. Pennsylvanian (Oread ls.); Missouri.

**Stenophragmidium**, n. name for *Stenophragma* Munro, 1912, not Skuse, 1890. Like *Stenopora*, with monilae and acanthopores but semi-diaphragms project from only one side of walls. Type species: *Stenophragma lobatum* Munro, 1912. Carboniferous of England.

Family Halloporidae Bassler, 1914

**Panderopora**, n. gen. Zoarium hemispheric with zoecia bearing distantly spaced, curved diaphragms and separated by small, closely tabulated mesopores. Type species: *Hallopora dybouskii* Bassler, 1911, p. 335, pl. 5, figs. 1-1e; text figs. 211, 212.

Family Constellariidae Ulrich, 1890

**Hennigopora**, n. gen. Like *Nicholsonella* but has clean cut acanthopores indenting the apertures and mesopores occupied by block like tabulae. Type species: *Callopora florida* Hall, 1852, p. 146, pl. 40, figs. 2a-f; Bassler, 1906, p. 38, pl. 14, figs. 10, 11. Clintonian; western New York.

**Revalotrypa**, n. gen. Like *Nicholsonella*, but diaphragms practically absent in both zoecia and mesopores. Granular wall structure as in *Dianulites*. Type species: *Nicholsonella gibbosa* Bassler, 1911, p. 224, fig. 126, pl. 11, figs. 1-6. Ordovician of Esthonia.

Family Phylloporinidae Ulrich, 1890

**Carinophylloporina**, n. gen. Like *Phylloporina*, but fenestrules angular, hexagonal, with a sharp carina dividing six parallel rows of apertures into two sets on the frontal as in *Septopora*; dorsal side longitudinally striated. Type species: *C. typica*, n. sp. The carina with three or four rows of closely spaced zoecia on each side almost vertically arranged is characteristic of the species. Blackriveran (Edinburg); ¼ mile east of Strasburg Junction, Va. Holotype: U.S.N.M. no. 116410 (Fig. 5) and paratypes (Figs. 6, 7).

**Oeciophylloporina**, n. gen. Like *Subretopora*, but branches divide and join again at considerable intervals forming very elongate fenestrules; ovicell-like structures, about width of branches, develop on frontal; dorsal bears longitudinal, granular striae. Species further characterized by well-separated, elevated circular peristomes and prominent acanthoporelike intervening nodes. Type species: *O. typicalis*, n. sp. Blackriveran (Edinburg); ¼ mile east of Strasburg Junction, Va. Holotype: U.S.N.M. no. 116414 (Fig. 8) and paratype (Fig. 9).

FIGS. 1-27.—1, *Flabellotrypa rugulosa*, n. gen. and sp., incrusting zoarium,  $\times 10$ ; 2, *Osburnostylus articulatus*, n. gen. and sp., segments with ends for articulation,  $\times 10$ ; 3, 4, *Canutrypa francqana*, n. gen. and sp., tangential and vertical thin sections,  $\times 20$ ; 5-7, *Carinophylloporina typica*, n. gen. and sp., frontal (5)  $\times 10$ , (6)  $\times 6$ , and striated dorsal (7),  $\times 10$ ; 8, 9, *Oeciophylloporina typicalis*, n. gen. and sp., frontal and dorsal,  $\times 15$ ; 10, 11, *Trepostomina crassa*, n. gen. and sp., frontal and dorsal sides,  $\times 8$ ; 12, 13, *Moorephyloporina typica*, n. gen. and sp., frontal and dorsal sides,  $\times 15$ ; 14, 15, *Hemulrichostylus lineatus*, n. gen. and sp., frontal and dorsal sides,  $\times 20$ ; 16-18, *Heminematopora virginiana*, n. gen. and sp., basal, frontal, and dorsal,  $\times 20$ ; 19-21, *Arthrostyleocia nitida*, n. gen. and sp., frontal (19, 20) and dorsal (21),  $\times 15$ ; 22-24, *Ottosectaxis bipartitus*, n. gen. and sp., tangential (22), transverse (23), and vertical (24) thin sections,  $\times 20$ ; 25-27, *Nemataxidra piercensis*, n. gen. and sp., tangential (25), transverse (26), and vertical (27) thin sections,  $\times 25$ .

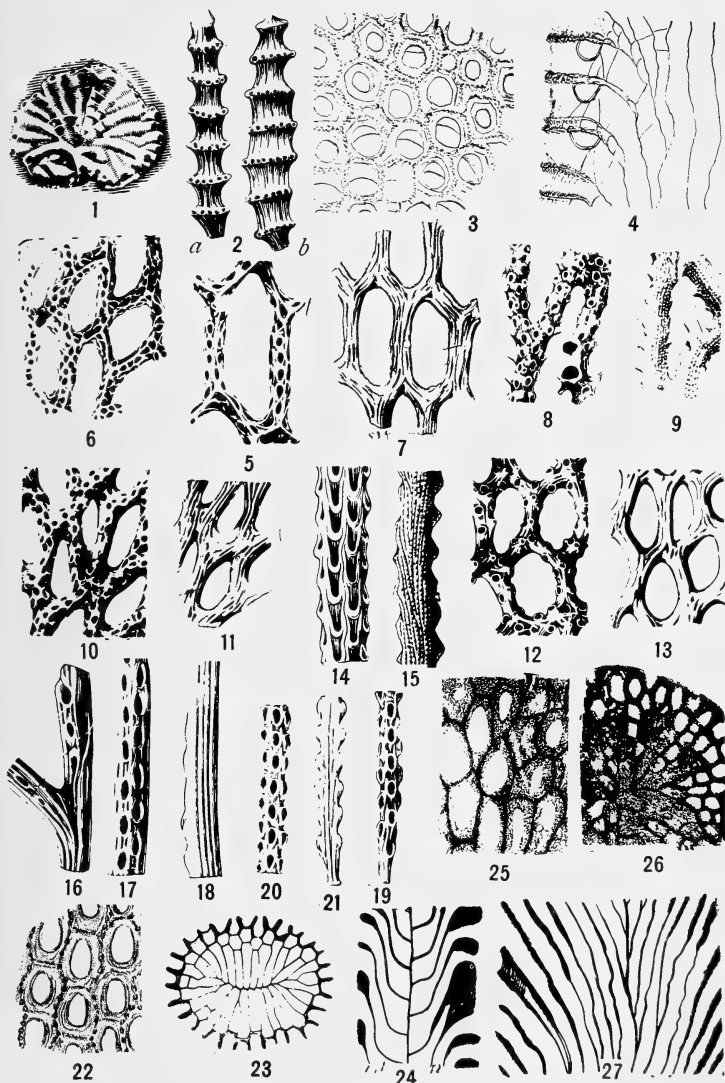

FIGS. 1-27.—(See opposite page for legend).

**Trepostomina**, n. gen. Zoarium of elongate reticulate fenestrules with three to five rows of angular, thick-walled zoecia on the frontal; dorsal coarsely striated. Type species: *T. crassa*, n. sp. Trepostomelike apertures alone form the frontal. Blackriveran (Edinburg);  $\frac{1}{4}$  mile of Strasburg Junction, Va. Holotype: U. S. N. M. no. 116413 (Fig. 10) and paratype (Fig. 11).

**Moorephylloporina**, n. gen. Like *Phylloporina* but fenestrules small, polygonal; frontal with two parallel rows of circular well-spaced apertures separated by a delicate thread or carina bearing elevated nodes (acanthopores) at regular intervals as in *Fenestella*. Dorsal side lines longitudinally with delicate striae. Type species: *M. typica* new species. The median dorsal carina with conspicuous nodes characterize the species. Blackriveran (Edinburg);  $\frac{1}{4}$  mile east of Strasburg Junction, Va. Holotype: U.S.N.M. no. 116413 (Fig. 12), paratype (Fig. 13).

**Sardesonina**, n. gen. Broad, closely reticulated branches of four to six rows of apertures traversed longitudinally by strong wavy carinae. Internal structure showing zoecial tubes with diaphragms, mesopores and acanthopores. Type species: *Phylloporina corticosa* Ulrich, 1893 (1886) p. 212, pl. 5, figs. 1-10. Blackriveran of southeastern Minnesota.

#### Order CRYPTOSTOMATA Vine, 1883

##### Family Arthrostylidae Ulrich, 1883

**Ulrichostylus**, n. gen. Narrow, cylindrical stems bearing eight or more longitudinally arranged zoecial rows. Base articulated, circular sockets on sides for new branches. Type species: *Helopora divaricatus* Ulrich (1886) 1893, p. 191, pl. 3, figs. 1-3. Blackriveran; southeastern Minnesota.

**Glaucnomella**, n. name (*Glaucnome* authors, non Goldfuss, 1829, Petr. Germ., p. 100, pl. 36, figs. 5-8, based on unrecognizable *Vincularias* from the Tertiary of Germany). Zoarium branching continuously into short, free, lateral stipes, with noncelluliferous back and no basal articulation. Type species: *Glaucnome disticha* Goldfuss, 1931, Petr. Germ., p. 217, pl. 64, fig. 15a, b. Wenlockian of England. (Selected as genotype of *Glaucnome* but unavailable since not in the 1829 section of Petr. Germ.)

**Hemulrichostylus**, n. gen. Like *Ulrichostylus* but jointed at base only and one of the sides with dorsal striations. Type species: *H. lineatus*, n. sp. The noncelluliferous broad dorsal side is the distinguishing character for the species. Blackriveran (Edinburg);  $\frac{1}{4}$  mile east of Strasburg Junction, Va. Holotype: U.S.N.M. no. 116412 (Fig. 14) and paratype (Fig. 15).

**Heminematopora**, n. gen. Like *Nematopora*, but one of the four sides without apertures and longitudinally striated. Type species: *H. virginiana*, n. sp. The delicate dichotomously branched zoarium with basal articulation only and one side longitudinally striated is easily recognized. Blackriveran (Edinburg);  $\frac{1}{4}$  mile east of Strasburg Junction, Va. Holotype: U.S.N.M. no. 116411 (Fig. 16), paratypes (Figs. 17, 18).

**Arthrostylocia**, n. gen. Delicate articulated segments like *Arthrostylus*, but apertures have distinct oval peristomes which often enlarge into cup-shaped ovicell-like structures. Type species: *A. nitida*, n. sp. Blackriveran (Edinburg);  $\frac{1}{4}$  mile east of Strasburg Junction, Va. Holotype: U.S.N.M. no. 116409 (Fig. 19), paratypes (Fig. 20, 21).

#### Family Rhabdomesontidae Vine, 1883

**Goldfussitrypa**, n. gen. Like *Rhombopora* in general structure but narrow branches of thick walled polygonal zoecia surrounded by rows of micracanthopores; diaphragms in immature region; no hemisepta. Type species: *Rhombopora esthonia* Bassler, 1911, p. 163, fig. 82, Middle Ordovician; Esthonia.

**Linotaxis**, n. gen. *Rhombopora* with zoecia arising gently from a central linear axis and a large megacanthopore at head of each aperture. Type species: *Orthopora? magna* McNair, 1942, p. 347, pl. 47, figs. 6, 10-12, Upper Devonian (Chemung); Rockville, N. Y.

**Ottoseetaxis**, n. gen. Narrow bifoliate smooth branches with wide immature zone followed by narrow mature one with each zoecium surrounded by a single row of micracanthopores but with neither hemisepta, diaphragms, nor mesopores developed. The bifoliate area is restricted to the immature zone. Type species: *O. bipartitus*, n. sp. Blackriveran (Benbolt); Knoxville, Tenn. (Figs. 22-24). Holotype: U.S.N.M. no. 116419.

**Nemataxidra**, n. gen. Like *Nemataxis* in internal structure except that diaphragms and superior and inferior hemisepta are wanting. Type species: *N. piercensis*, n. sp. Narrow smooth branches several millimeters in diameter with laminated structure reduced to a minimum and tubes arising in a central line. Blackriveran (Pierce); Murfreesboro, Tenn. Holotype: U.S.N.M. no. 117971 (Figs. 25-27).

**Nicklesopora**, n. gen. *Rhombopora* with a single row of micracanthopores around each zoecium. No diaphragms, hemisepta, mesopores, or central axis. Type species: *Rhombopora elegantula* Ulrich, 1884, p. 33, pl. 1, figs. 3-3b. Mississippian (New Providence); Kings Mountain, Ky.



*Saffordotaxis*, n. gen. Like *Nicklesopora*, but one or two rows of megacanthopores surround each zoecium. Type species: *Rhombopora incrassata* Ulrich (1888), 1890, p. 652, pl. 70, fig. 12a-d. Mississippian (New Providence); Kings Mountain, Ky.

*Streblascopora*, n. gen. Like *Streblotrypa*, but with a central bundle of parallel immature tubes as in *Ascopora*. Type species: *Streblotrypa*

*fasciculata* Bassler, 1929, p. 66, pl. 239, figs. 4, 5. Permian of Timor.

Order CHEILOSTOMATA Busk, 1852

Family Gigantoporidae Bassler, 1935

*Stenopsella*, n. name for *Stenopsis* Canu and Bassler, 1927, preoccupied by *Stenopsella* Rafinesque, 1815, etc. Type species: *Porina (Stenopsis) fenestrata* (Smitt, 1873), p. 47. Recent; Gulf of Mexico.

ZOOLOGY.—*The larva of Hymenolepis californicus in the brine shrimp (Artemia salina)*. R. T. YOUNG, University of Montana (*emeritus*). Communicated by E. W. Price.)

In 1933 Stammer described a remarkable cestode larva, *Cysticercus (Cercocystis) mirabilis*, in the water flea (*Daphnia magna*), which he postulated to be the larva of a *Hymenolepis* or *Aploparaksis* but was unable to verify his suspicion by feeding experiments on ducks, either domestic or wild. And examination of wild birds (2 *Podiceps cristatus*, 3 *Anas querquedula*, and 2 *Anas platyrhynchos*) from *Daphnia* ponds failed to reveal any cestodes whose hooks were similar to those of this larva. The most striking feature of Stammer's larva is the length of its tail (2.2-5.2 cm) while the body is only 0.091-0.104 mm long. Thus the parasite may be ten times the length of its host. I have found what is the same or a closely related species, in the brine shrimp of Mono Lake and salt pools near Chula Vista, Calif., which I here describe, together with a note on its life history.

*Technique*.—The larva has been studied mainly in freshly dissected shrimp flattened beneath a cover glass, but specimens fixed in Dubosq-Brazil's modification of Bouin's solution and stained in acetocarmine and Ehrlich's haematoxylin have also been employed.

*The larva*.—The larva, which corresponds to the "cyste" of Stammer, is an oval or oblong body varying in length from 0.073 to 0.256 mm in fresh specimens, and in diameter from 0.044 to 0.088. Six specimens averaged 0.153 in length and three 0.061 in diameter. They are encased in a heavy membrane or cuticle enclosing many round or oval chalk bodies, and a crown of 10 hooks, one of which is shown in Fig. 1. These hooks also vary in size from 0.008 to 0.017 mm.

These differences in size of body and hooks are undoubtedly mainly developmental.

Most of these larvae lie free in the body of the shrimp, but some of them are surrounded by a sack, to which is appended a tail of variable length. There is a small depression (pore?) in the membrane at the head end of the larva. Accurate measurement of the tail is impossible because of its bent and twisted form, being rolled about itself spirally as described by Daday (1900) in other species. I have however made an approximate estimate of its length in one specimen, illustrated in Fig. 2. In this it extended about 7 mm from the larval sack. Making due allowance for the amount of bending and coiling the length of this tail must have been at least 20 mm, which is considerably less than that recorded by Stammer.

My interest in this study was primarily ecological rather than morphological. Nevertheless I have made a sufficient comparison of my larva with that described by Stammer to convince me of the probable identity of the two forms.

Whether the free larva represents an early stage, the sack and tail being developed later, or a later stage, these structures having degenerated and disappeared, is an open question. Stammer apparently inclines to the latter view, for he says (p. 81) that in copepod infesting larvae the tail degenerates, and since there are a number of the latter which "in ihrem Bau dem unserer Form ähneln . . . (I cannot deny) dass diese Schwanzanhänge alle anzeichen einer ausgesprochenen Degeneration zeigen." However, on page 82 he describes one case of a young larva in which "die Cyste mit dem Scolex und den Haken war bereits vollständig ausgebildet,

dagegen hatte der Schwanzanhang noch nicht seine endgültige Struktur angenommen." I believe that both sack and tail are secondary developments, for I have seen what were undoubtedly different stages of the larva in one of which it was enveloped in a thin walled colorless sack containing only a few granules, while the fully developed larvae are surrounded by heavy sacks, brown in color and not transparent. Furthermore, the length of the tail varies in different specimens. In some it is but little longer than the larval body, while in others it exceeds this length one hundred fold or more. Sack and tail appear to develop later in the year, being more common in autumn than in summer. That sack and tail could be readily absorbed or ejected by the shrimp, as must be the case if they are degenerate structures, does not appear probable. And I have never seen fragmentary sacks or tails lying free in the body of the shrimp as might be expected if they were degenerate and in process of elimination. In only one case have I seen a larva lying free beside its sack and tail and in this instance a split in the former indicated the extrusion of the larva therefrom by extraneous pressure.

Many other cercocystis larvae have been described by various authors,<sup>1</sup> but none of them resemble *C. mirabilis* or the present form.

*The life history.*—Mono Lake, Calif., is the summer home of a colony of California gulls, *Larus californicus* (Young, 1950), which have nested for many years on an island in the lake. These gulls feed extensively on the larvae and pupae of the salt fly, *Ephydra*, and I at first assumed that these were the intermediate hosts of the tapeworm *Hymenolepis californicus*, which infests the gulls. However, feeding many hundred maggots and pupae to two young gulls which I hatched and reared in the laboratory was without result and an examination of several dozen of the former revealed no parasites, so that we can safely say that the fly larvae are not the intermediate hosts of the worm. An examination of several hundred brine shrimp from Mono Lake and the salt pools near Chula Vista revealed many specimens of the larva which feeding experiments with young gulls proved to be the larval stage of the tapeworm in the latter. In both 1950 and 1951 I obtained several specimens of the recently hatched birds and hatching eggs

in the colony. All the young out of the nest I examined were infested with this parasite, and 9 of 16 nestling birds harbored from one to many specimens. Of 14 hatching eggs I obtained in 1951, 7 of the birds subsequently died and 2 were used for other experiments, leaving 5 available for the present research. Feeding shrimp to these five birds resulted in infesting four of them with from one to ten worms. The birds were fed frozen fish and horse meat containing no live parasites.



FIG. 1.—Camera drawing of a larval hook.

Reverse experiments (transmission of parasites from bird to shrimp) were universally unsuccessful. Neither feeding eggs of the worm, some of which at least contained active embryos, to the shrimp nor placing the latter in dishes with feces of birds known to be infested gave a positive result in any experiment. This raises the question of the existence of any other possible organism on which the shrimp feed, but in the first place the latter feed mainly on nannoplankton, and in the second place it is very doubtful if any organism large enough to harbor the eggs of the parasite could be ingested by the shrimp.

There is some indirect evidence, however, which points rather strongly to a direct transfer from bird to shrimp. During the nesting season in June and July the gulls stay rather closely by their nests on the island, leaving it only to forage for food at a garbage dump on the lake shore or in nearby lakes in the mountains. In August and September, however, when the young are able to fly they are present in large numbers along the lake shore, picking up the fly larvae on which they feed, and depositing their feces in the water. In the former months a collection of 41 shrimps along the lake shore contained 9 larvae, while in August and October there were 100 larvae in 125 shrimp examined. These results are set forth in the following table which shows the dates of examination, the number of shrimp examined and the number of larvae per shrimp.

<sup>1</sup> See especially Daday (1900) and Hall (1929).

Date 1951 <sup>2</sup>	Number of shrimps	Number of larvae per shrimp
June 15-17	6	2/6
July 14	20	1/20
19	3	0/3
20	3	0/3
August 1	9	5/9
19	30	5/30
20	20	5/20
22	32	2/32
23	2	0/2
24	2	1/2
October 8	5	9/5
9	6	11/6
13	13	19/13
21	5	12/5
24-5	10	36/10

I have divided these experiments into two groups, one group including those from June 15 to August 1 inclusive, and the other including the remainder, and computed the probability of the results, based solely on chance, from a formula in Tippett (1937), i.e.,

$$T = \frac{X - X'}{S \sqrt{1/N + 1/N'}}$$

where  $X$  and  $X'$  are the larger and the smaller averages respectively of two sets of observations,  $N$  and  $N'$  the corresponding number of observations and

$$S^2 = \frac{\Sigma(x - X)^2 + \Sigma(x' - X')^2}{N - 1 + N' - 1}$$

$x$  and  $x'$  being the value of a given observation, i.e., the number of larvae in one shrimp.

Knowing the value of  $T$  and the number of observations the probability of the result can be determined from a table compiled by Dr. George F. McEwen, of the Scripps Institution of Oceanography.<sup>3</sup> Applied to the present series of observations this formula becomes

$$T = \frac{.8 - .22}{S \sqrt{1/125 + 1/41}} = \frac{.58}{S \times .057}, \text{ and } S = \frac{220.96 + 11.35}{124 + 40} = 1.4.$$

$$T, \text{ therefore} = \frac{.58}{1.4 \times .057} = 7.25 \text{ and the probability} = 0.$$

Had these observations been arranged differently, grouping all those in summer in compari-

<sup>2</sup>Dates given are those of examination of the shrimp. Dates of collection were June 12, July 12, August 17, and October 6.

<sup>3</sup>This table is based on one in Fisher's *Statistical methods for research workers*, but is more comprehensive.

son with those in October, after the shrimp had been exposed to the gulls for a longer time, the contrast would have been even greater.

Further indirect evidence of the passage of the parasite from bird to shrimp is afforded by an examination of the latter from the salt pools at Chula Vista in different seasons in comparison with that of the Mono Lake shrimp at the same time. In June and August 1951, when the gulls were numerous at Mono Lake, but rare or absent from the salt pools, the ratio of the infested shrimp in the former locality was 19/127, or 15 per cent, while that in the latter was 15/242, or 6.2 per cent.

Seasonal variation in abundance of *Cercocystis* in Entomostraca in relation to the presence or absence of their definitive hosts in different seasons has already been described by Daday (i.c.) and need not be further discussed here.

It is obvious that this indirect evidence is not proof of infestation of the shrimp by the gulls. It is possible, though very improbable that a third organism is involved. But the relationship between the amount of infestation of the shrimp and the abundance of the gulls at different seasons is very suggestive.



FIG. 2.—Microphotograph of a larva, showing the tail,  $\times 93$

The seasonal abundance of this larva is very different from that of Stammer's but the difference in the ecology of the daphnid and the shrimp and the different localities in which they are found may readily explain this.

*Summary.*—A remarkable cysticeroid (*Cercocystis*) in the brine shrimp of Mono Lake and the Chula Vista salt pools in California is described and figured. It resembles very closely, if it is not identical with the *Cysticerus mirabilis*

of Stammers (l.c.). (Should subsequent experiments prove the correctness of my assumption that this larva is identical with *Cysticercus mirabilis*, the specific name *californicus* will be superseded by *mirabilis*, which has priority.)

Feeding experiments with gulls (*Larus californicus*) have proved it to be the larva of *Hymenolepis californicus*, a parasite of this bird. It has not been possible to infest the shrimp with the larvae of the worm, but the percentage of infested shrimp in different seasons in relation to the abundance of the gulls at those seasons is strong indirect proof of the transfer of parasite from bird to shrimp.

*Acknowledgments.*—It gives me much pleasure to acknowledge my indebtedness to the San Diego Zoological Society and the U. S. Bureau of Animal Industry for the privilege of occupying

rooms in their laboratories and for many courtesies during the prosecution of this research. I am especially indebted to Dr. K. C. Kates of the latter institution for the microphotograph.

#### BIBLIOGRAPHY

- DADAY, E. VON. *Einige in Süßwasser-Entomotraken lebende Cercocystis-Formen*. Zool. Jahrb. **14**: 161-214. 1900.
- HALL, M. C. *Arthropods as intermediate hosts of helminths*. Smithsonian Misc. Coll. **81**: 775-852. 1929.
- STAMMER, H. J. *Eine neue eigenartige Cestoden larva; Cysticercus (Cercocystis) mirabilis, n. sp. aus Daphnia magna*. Zeitschr. Parasit. **6**: 76-90. 1933.
- TIPPETT, L. H. C. *The methods of statistics*. London, 1937.
- YOUNG, R. T. *Cestodes of California gulls*. Journ. Parasit. **36**: 9-12. 1950.

**HELMINTHOLOGY.**—*Helminths from the Republic of Panama: II, A new trematode from the intestine of Philander laniger pallidus Thomas and key to the species of the genus Phaneropsolus Looss, 1899 (Trematoda: Lecithodendriidae)*. EDUARDO CABALLERO Y C., Institute of Biology of Mexico, and ROBERT G. GROCOTT, Board of Health Laboratory, Ancon, Canal Zone.

The trematodes described below were collected in August 1950 from the intestine of a woolly opossum. The material consists of 15 specimens, all of which are whole stained mounts fixed without compression.

#### *Phaneropsolus philanderi*, n. sp.

The body in all specimens of the trematode is small, round in form, or shaped like a truncated cone with the anterior portion slightly narrowed and the posterior wide and flat. The flukes measures from 1.077 to 1.096 mm long by 1.096 to 1.172 mm broad. Cuticula 0.004 mm in thickness and in anterior region of ventral surface armed with numerous small, conical spines measuring 0.004 mm long. These spines are less numerous at the testicular level and disappear in the posterior part of the body. Spines very sparse on dorsal surface. Oral sucker is larger than acetabulum, almost spherical or widened transversely, terminally placed, muscular and measures 0.130 to 0.160 mm long by 0.210 to 0.227 mm broad. The spherical acetabulum is situated immediately anterior to the body equator, a little anterior to the reproductive glands and posterior to cirrus pouch at a distance of 0.294 to 0.344 mm from anterior end, and measures 0.134 to

0.168 mm long by 0.126 to 0.152 mm broad. The sucker ratio is 1:1.19 by 1:1.6 to 1:1.29 by 1:1.4.

The mouth is circular or slightly lengthened in transverse diameter and measures from 0.025 to 0.055 mm long and 0.109 to 0.118 mm broad. Prepharynx absent. Pharynx small, muscular, globoid, with transverse diameter greater than the anteroposterior and measures 0.055 to 0.067 mm long by 0.088 to 0.097 mm broad. Esophagus absent. Intestinal ceca short and narrow and extend dorsolaterally to the midtesticular zone.

The large circular genital pore is surrounded by a wide circular band of nucleated cells, measures 0.034 mm in diameter, and is situated slightly to the right of the midline at the level of the posterior border of the pharynx and 0.210 to 0.252 mm from the posterior end of body. The testes are laterally located in the equatorial plane of the parasite; they are spherical or oblong in shape, with smooth contour, size greater than that of ovary and one testis usually being larger than the other; right testis measures 0.134 to 0.185 mm long by 0.168 to 0.206 mm broad, while the left measures 0.168 to 0.273 mm long by 0.181 to 0.218 mm broad. The cirrus pouch is very long, tubular, located in the ventral region in front of the acetabulum and reproductive

glands and extends transversely from the level of the right testis to that of the left and measures 1.050 to 1.092 mm in length and 0.097 to 0.109 mm in breadth. The large seminal vesicle is bipartite, occupies the posterior part of the cirrus pouch, and measures 0.218 to 0.252 mm long by 0.055 to 0.067 mm broad. The pars prostatica occupies the greater part of the cirrus pouch and is composed of numerous cells with alveolated cytoplasm. The cirrus is short, thick, has the form of a truncated cone, and bears abundant tubercles on its surface.

The ovary is also situated in an equatorial position to the right of and posterior to the acetabulum; it is tangent to the right testis, spherical or oblong in shape, of smooth contour, smaller than the testes, and measures 0.113 to 0.155 mm long by 0.151 to 0.185 mm broad. The seminal receptacle is large, oblong, located posterior to the ovary and measures 0.176 to 0.214 mm long by 0.105 to 0.113 mm broad. Mehlis's gland is large, ventrally situated posterior to the acetabulum in the midline almost at the same level as the ovary, and measures from 0.105 to 0.176 mm in length by 0.088 to 0.113 mm in breadth. Laurer's canal present. The uterus fills almost the entire body and extends mainly over the lateral fields from behind the vitellaria to the posterior border of the body. In the central part of the body the uterine loops are sparse and the metraterm passes over to the left of the acetabulum toward the genital pore. The ova are very numerous, smooth-shelled, operculated, yellow, and measure 0.025 to 0.029 mm long by 0.015 to 0.017 mm broad.

The vitellaria occupy the lateral fields in the anterior part of the body, and at the level of the genital pore and cirrus pouch they consist of sparse but large vitelline follicles. The vitelline ducts are narrow and pass obliquely caudad to converge in the zone of Mehlis's gland. The excretory vesicle is V-shaped and occupies all the median and dorsal area in the posterior part of the body. The wide cornua of the vesicle extend to the posterior level of the testes, the right cornu measuring 0.311 to 0.496 mm long by 0.105 to 0.113 mm broad, the left 0.319 to 0.399 mm long by 0.084 to 0.126 mm broad. The excretory pore is subterminal, dorsally placed and surrounded by numerous cells that form a band around it. It is located 0.147 to 0.168 mm from the posterior border of the body.

*Host.*—*Philander laniger pallidus* Thomas.

*Habitat.*—Small intestine.

*Locality.*—Pedro Miguel, Panama Canal Zone.

*Specimens.*—Type specimen in helminthologic collection of the Institute of Biology of Mexico, no. 24-7. Cotype in U. S. National Museum helminthological collection.

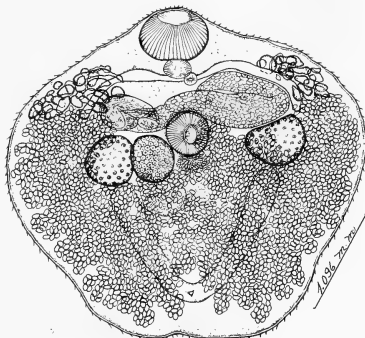

FIG. 1.—*Phaneropsolus philanderi*, n. sp.: Drawing of whole mount, ventral view.

*Discussion.*—At the present time six valid species of the genus *Phaneropsolus* Looss, 1899, are known. *Phaneropsolus micrococcus* (Rudolphi, 1819) Braun, 1901, whose synonym is *Phaneropsolus sigmoideus* Looss, 1899, parasitizes birds in Europe. The following five species parasitize mammals of the order Primates: *Phaneropsolus orbicularis* (Diesing, 1850) Braun, 1901; *Phaner-*

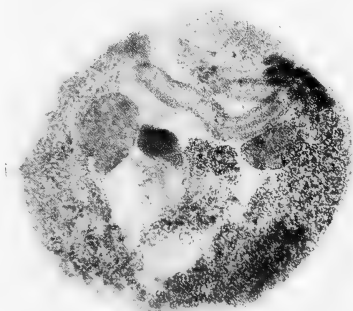

FIG. 2.—*Phaneropsolus philanderi*, n. sp.: Photomicrograph of whole mount, ventral view.

*opsolus oviforme* (Poirier, 1886) Looss, 1889; *Phaneropsolus longipenis* Looss, 1899; *Phaneropsolus lakdivensis* Fernando, 1933; and *Phaneropsolus bonnei* Lie-Kian-Joe, 1951. Since *Phaneropsolus sigmaideus* Looss, 1899, has been considered by Braun to be synonymous with *Phaneropsolus micrococcus* (Rudolphi, 1819) Braun, 1901, there then remains *Phaneropsolus oviforme* (Poirier, 1886) Looss, 1899, as the type species and the one Looss considered to be the second allocated to the new genus proposed by him.

Upon examining the descriptions and drawings of *Ph. oviforme* (Poirier, 1886) Looss, 1889, and *Ph. lakdivensis* Fernando, 1933, we have found that the two species are very similar and must therefore consider *Ph. lakdivensis* as a synonym of *Ph. oviforme* (Poirier, 1886) Looss, 1899. Also in carefully examining descriptions and figures of *Ph. longipenis* Looss, 1899 and those of *Ph. bonnei* Lie-Kian-Joe, 1951 we find that these two species are very similar in size and location of the cirrus pouch but differ in the location of the genital pore and other structures, the differences being great enough to consider them as distinct species.

Through the discovery of *Phaneropsolus philanderi* we have found that there exists no host specificity among the members of this genus since *Ph. micrococcus* (Rudolphi, 1899) Braun, 1901, parasitizes birds, *Passer domesticus* (Linnaeus) of the order Passeriformes, *Caprimulgus europaeus* (Linnaeus) of the order Caprimulgiformes, and *Glareola austriaca* Gmelin = *G. pratinctola* (Linnaeus) of the order Charadriiformes; *Ph. philanderi*, n. sp., parasitizes *Philander laniger pallidus* Thomas, a mammal of the order Marsupialia; *Ph. oviforme* (Poirier, 1886) Looss, 1899, lives in Primates of the suborder Lemuroidea such as *Nycticebus javanicus* and *Loris tardigradus*; *Ph. orbicularis* (Diesing, 1850) Braun, 1901, in *Cebus virvignatus* Humboldt of the order Primates, suborder Anthropoidea; *Ph. longipenis* Looss, 1899, also found in Primates of the suborder Anthropoidea and *Ph. bonnei* Lie-Kian-Joe, 1951, is found in *Homo sapiens* Linnaeus of the suborder Anthropoidea.

*Phaneropsolus philanderi*, n. sp., is similar to *Ph. longipenis* Looss, 1899, as to size of the cirrus pouch, but differs in the transverse position of the cirrus pouch, in the location of the genital pore which is to the left of the posterior border of the pharynx, and in the equatorial position of the reproductive glands. The remaining species of the

genus are distinguished mainly by the large size of the cirrus pouch and in the location of the genital pore and other structures.

#### KEY TO THE SPECIES OF PHANEROPSOLUS

##### I. Cirrus pouch very long.

1. Genital pore median and at level of posterior border of pharynx; cirrus pouch not transverse and testes preequatorial ..... *Ph. longipenis* Looss, 1899
2. Genital pore at level of posterior border of oral sucker; cirrus pouch not transverse and very much coiled; testes equatorial. .... *Ph. bonnei* Lie-Kian-Joe, 1951
3. Genital pore dislocated toward left of pharynx; cirrus pouch transverse and testes equatorial. .... *Ph. philanderi*, n. sp.

##### II. Cirrus pouch short.

1. Vitellaria arranged in lateral groups at level of intestinal bifurcation.
  - a. Esophagus absent; vitellaria not prececal; ceca not short. .... *Ph. micrococcus* (Rudolphi, 1819) Braun, 1901
  - b. Esophagus absent; vitellaria prececal and ceca short. .... *Ph. orbicularis* (Diesing, 1850) Braun, 1901
2. Vitellaria not arranged in lateral groups at level of intestinal bifurcation. .... *Ph. oviforme* (Poirier, 1886) Looss, 1899

#### BIBLIOGRAPHY

- BRAUN, M. *Zur Kenntnis der Trematoden der Säugethiere*. Zool. Jahrb., Abt. Syst., 14(4): 311-348. 1901a.
- . *Zur Revision der Trematoden der Vögel*. I. Zentrabl. Bakt. Parasit. und. Infek. 29(13): 560-568. 1901b.
- . *Fascioliden der Vögel*. Zool. Jahrb., Abt. Syst., 16(1): 1-162. 1902.
- DAVES, B. *The Trematoda*: xvi + 644 pp. London, 1946.
- FERNANDO, W. *Contribution to Ceylon helminthology*. 2. *Phaneropsolus lakdivensis* sp. nov., a trematode from the Ceylon slender loris (*Loris tardigradus*). Spol. Zeylanica 17(3): 149-154. 1933.
- FUHRMANN, O. *Zweite Klasse des Cladus Plathelminthes. Trematoda*. Handb. Zool. Kükenthal und Krumbach 2(3): 1-128. Leipzig, 1928.
- IMPERIAL BUREAU OF AGRICULTURE AND PARASITOLOGY. *The helminth parasites of marsupials*. Journ. Helm. 11(4): 195-256. 1933.
- LIE-KIAN-JOE. *Some human flukes from Indonesia*. Doc. Neerl. Ind. Morb. Trop. 3(2): 105-116. 1951.
- LOOSS, A. *Weitere Beiträge zur Kenntnis der Trematoden Fauna Aegyptens, zugleich Versuch einer natürlichen Gliederung des Genus Distomum Retzius*. Zool. Jahrb., Abt. Syst., 12(5/6): 521-784. 1899.
- MEHRA, H. R. *New trematodes of the family Lecithodendriidae Odhner, 1911, with a discussion on the classification on the family*. Proc. Acad. Sci. U.P. India 5(1): 99-121. 1935.

- NICOLL, W. A reference list of the trematode parasites of man and the primates. *Parasit.* **19**(3): 338-351. 1927.
- POIRIER, J. *Trematodes nouveaux ou peu-connu.* Bull. Soc. Philom. Paris, ser. 7, **10**: 20-40. 1886.
- SKARBILOVICH, T. S. Contribution to the reconstruction of the taxonomy of the trematodes of the family Lecithodendriidae Odhner, 1911. *Compt. Rend. (Doklady) Acad. Sci. U.R.S.S.* **38**(7): 223-224. 1943.
- SKRJBIN, K. I. *Trematody zhivotnykh i cheloveka.* Osnovy trematodologii **2**: 1-600. Isdatyelystvo Akademyi Nauk SSSR. Moskva-Lyeningrad, 1948. (In Russian).
- SRIVASTAVA, H. D. On new trematodes of frogs and fishes of the United Provinces India. *Bull. Acad. Sci. U.P. Agra. Oudh.* **3**(4): 239-256. 1934.
- STILES, CHARLES W., and HASSALL, A. *Index-catalogue of medical and veterinary zoology. Subjects: Trematoda and trematode diseases.* U. S. Hyg. Lab. Bull. **37**: 1-401. 1908.
- STILES, CHARLES W., and NOLAN, O. *Key-catalogue of parasites reported for primates (monkeys and lemurs) with their possible public health importance.* U. S. Hyg. Lab. Bull. **152**: 409-601. 1929.
- TRAVASSOS, L. *Contribuições para o conhecimento da fauna helmintológica brasileira. XV. Sobre as espécies brasileiras da família Lecithodendriidae Odhner, 1911.* Arch. Esc. Sup. Agr. Med. Vet. **5**(1/2): 73-79. 1921.
- . *Contribuição para o conhecimento dos Lecithodendriidae do Brasil.* Mem. Inst. Oswaldo Cruz **21**: 189-194. 1928.
- VIANA, L. *Tentativa de catalogação das espécies brasileiras de trematodos.* Mem. Inst. Oswaldo Cruz **17**: 95-227. 1924.

MAMMALOGY.—A new name for *Dipodomys ordii fuscus* Setzer. HENRY W. SETZER, U. S. National Museum.

It has been called to my attention that the name *Dipodomys ordii fuscus* (Setzer, Univ. Kansas Publ. Mus. Nat. Hist. **1** (23): 555. Dec. 27, 1949) is preoccupied by the name *Dipodomys agilis fuscus* (Boulware, Univ. California Publ. Zool. **46** (7): 393. Sept. 16, 1943). I therefore

propose the name *Dipodomys ordii durranti*, in recognition of Dr. Stephen David Durrant of the University of Utah, to replace the name *Dipodomys ordii fuscus*. I also wish to correct the spelling of the name of the type locality from Juamave to Jaumave, Tamaulipas, Mexico.

## Obituary

ALBERT EUGENE MCPHERSON, a senior materials engineer in the National Bureau of Standards' engineering mechanics laboratory, died on August 5, 1952, at his home near Washington, D. C. Mr. McPherson had been a Bureau employee since 1926. His primary field of research was in the field of aircraft structures and materials. While at the Bureau Mr. McPherson was author of a large number of technical articles published by various technical societies, the National Advisory Committee for Aeronautics, and the National Bureau of Standards. He held patents on two types of accelerometers used in his work.

For many years the National Bureau of Standards has conducted an extensive research program in the field of aeronautics. The program extends from the development of temperature sensing devices for jet engines to the stress analy-

sis of aircraft structures. Mr. McPherson was senior engineer in the Aircraft Structures Group which dealt primarily with the structural strength of basic aircraft components. This included research in the field of dynamic response of simple structures and development of instruments for measuring force acceleration and deformation.

Mr. McPherson was a member of the Washington Academy of Sciences, the Philosophical Society of Washington, the Institute of Aeronautical Sciences, and secretary of the Washington Chapter of the Society for Experimental Stress Analysis.

Mr. McPherson was born in Washington on January 27, 1908. He attended George Washington University and received his degree in mechanical engineering in 1933. He is survived by his wife, a daughter, and his father.

# INDEX TO VOLUME 42

An asterisk (\*) denotes the abstract of a paper presented before the Academy or an affiliated society.

## PROCEEDINGS OF THE ACADEMY AND AFFILIATED SOCIETIES

Anthropological Society of Washington. 367.  
 Washington Academy of Sciences. 59, 135, 161, 198, 271, 309.  
 Philosophical Society of Washington. 333.

### AUTHOR INDEX

- ABELSON, PHILIP H. \* Isotope tracers: Past, present, and future. 333.
- ANDERSEN, HAROLD V. *Buccella*, a new genus of the rotalid Foraminifera. 143.
- BARTRAM, EDWIN B. New mosses from southern Brazil. 178.
- BASSLER, R. S. Taxonomic notes on genera of fossil and Recent Bryozoa. 381.
- BATTEN, ROGER L. The type species of the gastropod genus *Protostylus*. 355.
- BAYER, FREDERICK M. A new *Calyptrophora* (Coelenterata: Octocorallia) from the Philippine Islands. 82.
- . New western Atlantic records of octocorals (Coelenterata: Anthozoa), with descriptions of three new species. 183.
- BEAMS, J. W. \* Some recent developments in the production of high rotational speeds and their application. 342.
- BENNETT, ROBERT R., and COLLINS, GLENN GENE. Brightseat formation, a new name for sediments of Paleocene age in Maryland. 114.
- BERDAN, JEAN M. See SOHN, I. G. 7.
- BLOEDORN, WALTER A. Oscar Benwood Hunter (obituary). 272.
- BRIDWELL, J. C. A new genus of Bruchidae affecting *Hibiscus* in Argentina (Bruchinae: Acanthoscelidini). 49.
- . Notes on Bruchidae affecting the Anacardiaceae, including the description of a new genus. 124.
- BURSTEIN, ELIAS. \* Optical properties of diamond, silicon, and germanium. 342.
- CABALLERO Y C., EDUARDO, and GROCOTT, ROBERT G. Helminths from the Republic of Panama: II, A new trematode from the intestine of *Philander laniger pallidus* Thomas and key to the species of the genus *Phanerozotus* Looss, 1899 (Trematoda: Lecithodendriidae). 388.
- CAMP, GLENN D. \* Operations research: A quantitative aid to executive decision. 335.
- CHAMBERLIN, RALPH V. An arrangement of the Prepodosmidae, a family of African millipeds. 327.
- CHAPMAN, SYDNEY. Meteors and meteorites. 273.
- CHASE, AGNES. New species of grasses from Venezuela. 122.
- CHAVAN, A. Nomenclatural notes on carditids and lucinids. 116.
- CLARK, AUSTIN H. Notes on the history and distribution of the reptiles. 262.
- CLARKE, J. F. GATES. A new carpenterworm from Florida (Lepidoptera: Cossidae). 156.
- COCHRAN, DORIS M. Two Brazilian frogs: *Hyla werneri*, n. nom., and *Hyla similis*, n. sp. 50.
- COE, WESLEY R. Geographical distribution of the species of nemerteans of the Arctic Ocean near Point Barrow, Alaska. 55.
- COLE, KENNETH S. \* Progress in biophysics. 339.
- COLLINS, GLENN GENE. See BENNETT, ROBERT R., 114.
- COURTNEY, WILBUR D. The teasel nematode, *Ditylenchus dipsaci* (Kühn, 1857), Filipjev, 1936. 303.
- DAMON, S. C. On the fungus genera *Titaea*, *Mono-grammia*, and *Araneomyces*. 365.
- DEXTER, RALPH W. See SPECK, FRANK G. 1.
- DU BUY, H. G. See WOODS, M. W. 169.
- DUNKLE, DAVID H., and WILSON, JOHN A. Remains of Devonian fishes from Texas. 213.
- DURBIN, CHARLES G. A new roundworm, *Capillaria pirangae* (Nematoda: Trichinellidae), from the scarlet tanager (*Piranga erythromelas*). 238.
- EMERSON, WILLIAM K. Generic and subgeneric names in the molluscan class Scaphopoda. 296.
- EMILIANI, CESARE. Nomenclature and grammar. 137.
- FERGUSON, H. G. Paleozoic of western Nevada. 72.
- FISCHER, EARL K. \* High-speed motion pictures as a research tool. 336.
- FOSHAG, W. F. Merrill Bernard (obituary). 104.
- FRIEDMANN, HERBERT. James Lee Peters (obituary). 312.
- . The long-tailed sugarbird of eastern Rhodesia. 31.
- GAMOW, GEORGE. \* The first half hour of creation. 334.
- GERSDORFF, W. A., and MITLIN, NORMAN. A bioassay of some stereoisomeric constituents of allethrin. 313.
- GIBSON, R. E. \* An introduction to the natural philosophy of guided missiles. 338.
- GINSBURG, ISAAC. Eight new fishes from the Gulf coast of the United States, with two new genera and notes on geographic distribution. 84.
- GOSLINE, WILLIAM A. Notes on the systematic status of four eel families. 130.
- GRAHAM, J. W. \* The determination of the earth's field in geologic time. 335.
- GROCOTT, ROBERT G. See CABALLERO Y C., EDUARDO. 388.
- HAFSTAD, L. R. \* The reactor program of the Atomic Energy Commission. 334.



- HANDLEY, CHARLES O., JR. A new pine mouse (*Pitymys pinetorum carbonarius*) from the southern Appalachian Mountains. 152.
- HARRIS, D. V. See REESIDE, J. B., JR. 174.
- HARTLINE, H. K. \* The electrical activity of optic nerve fibers. 341.
- HARTMAN, OLGA. The marine annelids of the United States Navy Antarctic Expedition, 1947-48. 231.
- HAWKS, EMMA B. Claribel Ruth Barnett (obituary). 167.
- HOPKINS, G. H. E. Notes on synonymy in Siphonaptera. 363.
- HOTTES, F. C. Descriptions and notes on two rare species of Aphididae. 127.
- HULL, GEORGE F. \* The properties of microwaves. 337.
- JAMES, MAURICE T. The Ethiopian genera of Sarginae, with descriptions of new species. 220.
- JENKINS, ANNA E., and MILLER, JULIAN H. A new species of *Sphaceloma* on magnolia. 323.
- JOHNSON, THOMAS H. \* The place and future of organized research in modern society. 344.
- KEARNEY, T. H. Walter T. Swingle (obituary). 208.
- KENK, ROMAN. Fresh-water triclads (Turbellaria) of the Rocky Mountain National Park region, Colorado. 193.
- KERSHNER, R. B. \* Foundations of arithmetic. 340.
- KING, PHILIP B. The base of the Cambrian in the southern Appalachians. 170.
- KRACEK, FRANK C. \* The application of thermochemistry to geophysical problems. 335.
- LADD, H. S. Thomas Wayland Vaughan (obituary). 207.
- LEVITON, ALAN E. A new Philippine snake of the genus *Calamaria*. 239.
- LI, HUI-LIN. Notes on some families of Formosan phanerogams. 39.
- LION, KURT S. \* Physics in vision and fatigue. 341.
- LITTLE, ELBERT L. Notes on *Frazinus* (ash) in the United States. 369.
- LOCKER, BETTY, and RAUSCH, ROBERT. Some cestodes from Oregon shrews, with descriptions of four new species of *Hymenolepis* Weiland, 1858. 26.
- LOEBLICH, ALFRED R., JR. *Ammopemphix*, new name for the Recent foraminiferal genus *Urnula* Wiesner. 82.
- . New Recent foraminiferal genera from the tropical Pacific. 189.
- and TAPPAN, HELEN. *Adercotryma*, a new Recent foraminiferal genus from the Arctic. 141.
- . *Cribrotextularia*, a new foraminiferal genus from the Eocene of Florida. 79.
- . Morphology of the test in the foraminiferal genus *Tristix* Macfayden. 356.
- . *Poritextularia*, a new Recent foraminiferal genus. 264.
- LONGWELL, CHESTER R. Lower limit of the Cambrian in the Cordilleran region. 209.
- MAHAN, A. I. \* Some of the geometrical, physical, and physiological properties of light. 343.
- MATTOX, N. T. A new genus and species of Limnadiidae from Venezuela (Crustacea: Conchostraca). 23.
- MAXWELL, E. \* Recent developments in superconductivity. 336.
- MCCONNELL, DUNCAN. The nature of rock phosphates, teeth, and bones. 36.
- MCCOY, GEORGE W. Maurice Isadore Smith (obituary). 136.
- METCALF, Z. P. New names in the Homoptera. 226.
- MILLER, JULIAN H. See JENKINS, ANNA E. 323.
- MITLIN, NORMAN. See GERSDORFF, W. A. 313.
- MOOJEN, JOÃO. A new *Clyomys* from Paraguay (Rodentia: Echimyidae). 102.
- NICOL, DAVID. A new glycymerid from the Western Atlantic. 266.
- . A rare Tertiary glycymerid from South Carolina and Florida. 362.
- . Designation of the type species of *Pseudochama* (additional note). 248.
- . Nomenclatural review of genera and subgenera of Chamidae. 154.
- PAGE, CHARLES H. \* The mathematical theory of communication. 335.
- PAGE, THORNTON. \* Density of matter in the universe. 342.
- PARR, A. E. Revision of the genus *Talismania*, with description of a new species from the Gulf of Mexico. 268.
- POLLARD, ERNEST. \* The physics of viruses. 337.
- RAUSCH, ROBERT. See LOCKER, BETTY. 26.
- REESIDE, J. B., JR., and HARRIS, D. V. A Cretaceous horseshoe crab from Colorado. 174.
- RICE, FRANCIS O. \* Recent advances in free radical chemistry. 339.
- RIDENOUR, LOUIS N. \* Present and future trends in electronics. 338.
- ROBACK, SELWYN S. New species of Sarcophagini (Diptera: Sarcophagidae). 45.
- ROTH, VINCENT D. A review of the genus *Teegenaria* in North America (Arachnida: Agelenidae). 283.
- RUARK, ARTHUR E. \* How to understand relativity. 339.
- SABROSKY, CURTIS W. A new larvaevorid fly parasitic on tortoise beetles in South America (Diptera). 325.
- SCHILLER, EVERETT L. *Hymenolepis johnsoni*, n. sp., a cestode from the vole *Microtus pennsylvanicus drummondii*. 53.
- SETZER, HENRY W. A new name for *Dipodomys ordii fuscus* Setzer. 391.
- SMITH, LYMAN B. A new *Guzmania* from Colombia. 282.
- . A new *Nymphoides* from Colombia. 160.
- SHOWACRE, JANE L. See WOODS, M. W. 169.
- SOHN, I. G., and BERDAN, JEAN M. Stratigraphic range of the ostracode genus *Phanassymetria* Roth. 7.
- SPECK, FRANK G., and DEXTER, RALPH W. Utilization of animals and plants by the Malecite Indians of New Brunswick. 1.
- SPITZ, RENE A. \* Methodological consideration in psychoanalytical research. 337.
- SPITZER, LYMAN. \* The formation of stars. 336.

- STANNARD, LEWIS J., JR. Phylogenetic studies of *Franklinothrips* (Thysanoptera: Aeolothripidae). 14.
- STOSE, GEORGE W. The Murphree Valley anticline, Alabama. 241.
- STRIMPLE, HARRELL L. New species of *Lecanocrinus*. 318.
- . Some new species of crinoids from the Henryhouse formation of Oklahoma. 75.
- . The arms of *Haerteocrinus*. 245.
- . The arms of *Polusocrinus*. 12.
- . Notes on *Texocrinus*. 216.
- . Two new species of *Sinclairiocyrtis*. 158.
- STRONG, JOHN. \*The new Johns Hopkins ruling engine. 334.
- TAPPAN, HELEN. See LOEBLICH, ALFRED R., JR. 79, 141, 264, 356.
- TAYLOR, FRANKLIN V. \*Research on man-made systems. 344.
- TRAUB, ROBERT. *Johnsonaeapsylla audyi*, a new genus and new species of flea from North Borneo, with notes on the subfamily Leptopsyllinae (Siphonaptera). 288.
- TRUESDELL, C. Preliminary report: Nonlinear absorption and dispersion of plane ultrasonic waves in pure fluids. 33.
- WEISEL, GEORGE F. Animal names, anatomical terms, and some ethnology of the Flathead Indians. 345.
- WHEELER, GEORGE C., and WHEELER, JEANETTE. The ant larvae of the myrmicine tribe Crematogastrini. 248.
- WHITE, ROBERT M. Some applications of physical anthropology. 65.
- WILSON, JOHN A. See DUNKLE, DAVID H. 213.
- WOODS, M. W., SHOWACRE, JANE L., and DU BUY, H. G. Reaction of normal and mutant plastids of *Nicotiana* to neotetrazolium. 169.
- YAGODA, HERMAN. \*The mesons of cosmic-ray physics. 343.
- YOUNG, R. T. The larva of *Hymenolepis californicus* in the brine shrimp (*Artemia salina*). 385.
- ZIMMER, JOHN T. A new finch from northern Perú. 103.
- ZOCH, RICHMOND T. On the variation of the average daily temperature at Washington, D. C. 105.

## SUBJECT INDEX

- Anthropology.** Some applications of physical anthropology. ROBERT M. WHITE. 65.
- Astronomy.** Meteors and meteorites. SYDNEY CHAPMAN. 273.
- \* The formation of stars. LYMAN SPITZER. 336.
- Biochemistry.** A bioassay of some stereoisomeric constituents of allethrin. W. A. GERSDORFF and NORMAN MITLIN. 313.
- Reaction of normal and mutant plastids of *Nicotiana* to neotetrazolium. M. W. WOODS, JANE L. SHOWACRE, and H. G. DU BUY. 169.
- Biophysics.** \* Physics in vision and fatigue. KURT S. LION. 341.
- \* Progress in biophysics. KENNETH S. COLE. 339.
- \* The electrical activity of optic nerve fibers. H. K. HARTLINE. 341.
- \* The physics of viruses. ERNEST POLLARD. 337.
- Botany.** A new *Guzmania* from Colombia. LYMAN B. SMITH. 282.
- A new *Nymphoides* from Colombia. LYMAN B. SMITH. 160.
- A new species of *Sphaceloma* on magnolia. ANNA E. JENKINS and JULIAN H. MILLER. 323.
- New mosses from southern Brazil. EDWIN B. BARTRAM. 178.
- New species of grasses from Venezuela. AGNES CHASE. 122.
- Notes on *Fraxinus* (ash) in the United States. ELBERT L. LITTLE. 369.
- Notes on some families of Formosan phanerogams. HUI-LIN LI. 39.
- Chemistry.** \* Recent advances in free radical chemistry. FRANCIS O. RICE. 339.
- Engineering psychology.** \* Research on man-made systems. FRANKLIN V. TAYLOR. 344.
- Entomology.** A new carpenterworm from Florida (Lepidoptera: Cossidae). J. F. GATES CLARKE. 156.
- A new genus of Bruchidae affecting *Hibiscus* in Argentina (Bruchinae: Acanthoscelidini). J. C. BRIDWELL. 49.
- A new larvaevorid fly parasitic on tortoise beetles in South America (Diptera). CURTIS W. SABROSKY. 325.
- A review of the genus *Tegenaria* in North America (Arachnida: Agelenidae). VINCENT D. ROTH. 283.
- An arrangement of the Prepodesmidae, a family of African millipeds. RALPH V. CHAMBERLIN. 327.
- Descriptions and notes on two rare species of Aphididae. F. C. HOTES. 127.
- Johnsonaeapsylla audyi*, a new genus and new species of flea from North Borneo, with notes on the subfamily Leptopsyllinae (Siphonaptera). ROBERT TRAUB. 288.
- New names in the Homoptera. Z. P. METCALF. 226.
- New species of Sarcophagini (Diptera: Sarcophagidae). SELWYN S. ROBACK. 45.
- Notes on Bruchidae affecting the Anacardiaceae, including the description of a new genus. J. C. BRIDWELL. 124.
- Notes on synonymy in Siphonaptera. G. H. E. HOPKINS. 363.
- Phylogenetic studies of *Franklinothrips* (Thysanoptera: Aeolothripidae). LEWIS J. STANNARD, JR. 14.
- The ant larvae of the myrmicine tribe Crematogastrini. GEORGE C. WHEELER and JEANETTE WHEELER. 248.

- The Ethiopian genera of Sarginae, with descriptions of new species. MAURICE T. JAMES. 220.
- Ethnology*. Animal names, anatomical terms, and some ethnozoology of the Flathead Indians. GEORGE F. WEISEL. 345.
- Utilization of animals and plants by the Malecite Indians of New Brunswick. FRANK G. SPECK and RALPH W. DEXTER. 1.
- Geology*. Brightseat formation, a new name for sediments of Paleocene age in Maryland. ROBERT R. BENNETT and GLENN GENE COLLINS. 114.
- Lower limit of the Cambrian in the Cordilleran region. CHESTER R. LONGWELL. 209.
- Paleozoic of western Nevada. H. G. FERGUSON. 72.
- The base of the Cambrian in the southern Appalachians. PHILIP B. KING. 170.
- The Murphree Valley anticline, Alabama. GEORGE W. STOSE. 241.
- Geophysics*. \* The application of thermochemistry to geophysical problems. FRANK C. KRACEK. 335.
- \* The determination of the earth's field in geologic time. J. W. GRAHAM. 335.
- Helminthology*. Helminths from the Republic of Panama: II, A new trematode from the intestine of *Philander lamiger pallidus* Thomas and key to the species of the genus *Phanerozoolus* Looss, 1899 (Trematoda: Lecithodendriidae). EDUARDO CABALLERO Y C. and ROBERT G. GROCOTT. 388.
- Hymenolepis johnsoni*, n.sp., a cestode from the vole *Microtus pennsylvanicus drummondii*. EVERETT L. SCHILLER. 53.
- Some cestodes from Oregon shrews, with descriptions of four new species of *Hymenolepis* Weinland, 1858. BETTY LOCKER and ROBERT RAUSCH. 26.
- Herpetology*. A new Philippine snake of the genus *Calamaria*. ALAN E. LEVITON. 239.
- Two Brazilian frogs: *Hyla werneri*, n.nom., and *Hyla similis*, n.sp. DORIS M. COCHRAN. 50.
- Ichthyology*. Eight new fishes from the Gulf coast of the United States, with two new genera and notes on geographic distribution. ISAAC GINSBURG. 84.
- Notes on the systematic status of four eel families. WILLIAM A. GOSLINE. 130.
- Revision of the genus *Talismania*, with description of a new species from the Gulf of Mexico. A. E. PARR. 268.
- Malacology*. A new glycymerid from the Western Atlantic. DAVID NICOL. 266.
- Generic and subgeneric names in the molluscan class Scaphopoda. WILLIAM K. EMERSON. 296.
- Nomenclatural review of genera and subgenera of Chamidae. DAVID NICOL. 154.
- Mammalogy*. A new *Clyomys* from Paraguay (Rodentia: Echimyidae). JOÃO MOOJEN. 102.
- A new name for *Dipodomys ordii fuscus* Setzer. HENRY W. SETZER. 391.
- A new pine mouse (*Pitymys pinetorum carbonarius*) from the southern Appalachian Mountains. CHARLES O. HANDLEY, JR. 152.
- Mathematics*. \* Foundations of arithmetic. R. B. KERSHNER. 340.
- \* The mathematical theory of communication. CHESTER H. PAGE. 335.
- Meteorology*. On the variation of the average daily temperature at Washington, D. C. RICHMOND T. ZOCH. 105.
- Mineralogy*. The nature of rock phosphates, teeth, and bones. DUNCAN MCCONNELL. 36.
- Mycology*. On the fungus genera *Titaea*, *Monogrammia*, and *Araneomyces*. S. C. DAMON. 365.
- Nematology*. A new roundworm, *Capillaria pirangae* (Nematoda: Trichinellidae), from the scarlet tanager (*Piranga erythromelas*). CHARLES G. DURBIN. 238.
- The teasel nematode, *Ditylenchus dipsaci* (Kühn, 1857), Filipjev, 1936. WILBUR D. COURTNEY. 303.
- Obituaries*
- Barnett, Claribel Ruth. 167.  
 Bernard, Merrill. 104.  
 Fischer, Earl K. 64.  
 French, Owen Bert. 64.  
 Hunter, Oscar Benwood. 272.  
 McPherson, Albert Eugene. 391.  
 Peters, James Lee. 312.  
 Smith, Maurice Isadore. 136.  
 Swingle, Walter T. 208.  
 Vaughan, Thomas Wayland. 207.
- Operations research*. \* Operations research: A quantitative aid to executive decision. GLENN D. CAMP. 335.
- Ornithology*. A new finch from northern Perú. JOHN T. ZIMMER. 103.
- The long-tailed sugarbird of eastern Rhodesia. HERBERT FRIEDMANN. 31.
- Paleontology*. A Cretaceous horseshoe crab from Colorado. J. B. REESIDE, JR., and D.V. HARRIS. 174.
- A rare Tertiary glycymerid from South Carolina and Florida. DAVID NICOL. 362.
- Cribrotectularia*, a new foraminiferal genus from the Eocene of Florida. ALFRED R. LOEBLICH, JR., and HELEN TAPPAN. 79.
- Designation of the type species of *Pseudochama* (additional note). DAVID NICOL. 248.
- Morphology of the test in the foraminiferal genus *Tristix* Macfayden. ALFRED R. LOEBLICH, JR., and HELEN TAPPAN. 356.
- New species of *Lecanocrinus*. HARRELL L. STRIMPLE. 318.
- Nomenclatural notes on carditids and lucinids. A. CHAVAN. 116.
- Notes on *Texacrinus*. HARRELL L. STRIMPLE. 216.
- Remains of Devonian fishes from Texas. DAVID H. DUNKLE and JOHN A. WILSON. 213.

- Some new species of crinoids from the Henryhouse formation of Oklahoma. HARRELL L. STRIMPLE. 75.
- Stratigraphic range of the ostracode genus *Phanassymeria* Roth. I. G. SOHN and JEAN M. BERDAN. 7.
- Taxonomic notes on genera of fossil and Recent Bryozoa. R. S. BASSLER. 381.
- The arms of *Haerteocrinus*. HARRELL L. STRIMPLE. 245.
- The arms of *Polusocrinus*. HARRELL L. STRIMPLE. 12.
- The type species of the gastropod genus *Protostylus*. ROGER L. BATTEN. 355.
- Two new species of *Sinclairocystis*. HARRELL L. STRIMPLE. 158.
- Photography*. \* High-speed motion pictures as a research tool. EARL K. FISCHER. 336.
- Physics*. \* An introduction to the natural philosophy of guided missiles. R. E. GIBSON. 338.
- \* Density of matter in the universe. THORNTON PAGE. 342.
- \* How to understand relativity. ARTHUR E. RUARK. 339.
- \* Isotope tracers: Past, present, and future. PHILIP H. ABELSON. 333.
- \* Optical properties of diamond, silicon, and germanium. ELIAS BURSTEIN. 342.
- Preliminary report: Nonlinear absorption and dispersion of plane ultrasonic waves in pure fluids. C. TRUESDELL. 33.
- \* Present and future trends in electronics. LOUIS N. RIDENOUR. 338.
- \* Recent developments in superconductivity. E. MAXWELL. 336.
- \* Some of the geometrical, physical, and physiological properties of light. A. I. MAHAN. 343.
- \* Some recent developments in the production of high rotational speeds and their application. J. W. BEAMS. 342.
- \* The first half hour of creation. GEORGE GAMOW. 334.
- \* The mesons of cosmic-ray physics. HERMAN YAGODA. 343.
- \* The new Johns Hopkins ruling engine. JOHN STRONG. 334.
- \* The properties of microwaves. GORDON F. HULL. 337.
- \* The reactor program of the Atomic Energy Commission. L. R. HAFSTAD. 334.
- Psychoanalysis*. \* Methodological consideration in psychoanalytical research. RENE A. SPITZ. 337.
- Scientific research*. \* The place and future of organized research in modern society. THOMAS H. JOHNSON. 344.
- Systematic zoology*. Nomenclature and grammar. CESARE EMILIANI. 137.
- Zoology*. A new *Calyptrophora* (Coelenterata: Octocorallia) from the Philippine Islands. FREDERICK M. BAYER. 82.
- A new genus and species of Limnadiidae from Venezuela (Crustacea: Conchostraca). N. T. MATTOX. 23.
- Adercotryma*, a new Recent foraminiferal genus from the Arctic. ALFRED R. LOEBLICH, JR., and HELEN TAPPAN. 141.
- Ammopemphix*, new name for the Recent foraminiferal genus *Urnula* Wiesner. ALFRED R. LOEBLICH, JR. 82.
- Buccella*, a new genus of the rotalid Foraminifera. HAROLD V. ANDERSEN. 143.
- Fresh-water tricolads (Turbellaria) of the Rocky Mountain National Park region, Colorado. ROMAN KENK. 193.
- Geographical distribution of the species of nemertean of the Arctic Ocean near Point Barrow, Alaska. WESLEY R. COE. 55.
- New Recent foraminiferal genera from the tropical Pacific. ALFRED R. LOEBLICH, JR. 189.
- New western Atlantic records of octocorals (Coelenterata: Anthozoa), with descriptions of three new species. FREDERICK M. BAYER. 183.
- Notes on the history and distribution of the reptiles. AUSTIN H. CLARK. 262.
- Poritextularia*, a new Recent foraminiferal genus. ALFRED R. LOEBLICH, JR., and HELEN TAPPAN. 264.
- The larva of *Hymenolepis californicus* in the brine shrimp (*Artemia salina*). R. T. YOUNG. 385.
- The marine annelids of the United States Navy Antarctic Expedition, 1947-48. OLGA HARTMAN. 231.

## Officers of the Washington Academy of Sciences

President.....	WALTER RAMBERG, National Bureau of Standards
President-elect.....	F. M. SETZLER, U. S. National Museum
Secretary.....	F. M. DEFANDORF, National Bureau of Standards
Treasurer.....	HOWARD S. RAPPLEYE, U. S. Coast and Geodetic Survey
Archivist.....	JOHN A. STEVENSON, Plant Industry Station
Custodian and Subscription Manager of Publications	HARALD A. REHDER, U. S. National Museum

### Vice-presidents Representing the Affiliated Societies:

Philosophical Society of Washington.....	A. G. McNISH
Anthropological Society of Washington.....	WALDO R. WEDEL
Biological Society of Washington.....	HUGH T. O'NEILL
Chemical Society of Washington.....	JOHN K. TAYLOR
Entomological Society of Washington.....	FREDERICK W. POOS
National Geographic Society.....	ALEXANDER WETMORE
Geological Society of Washington.....	A. NELSON SAYRE
Medical Society of the District of Columbia.....	FRED O. COE
Columbia Historical Society.....	GILBERT GROSVENOR
Botanical Society of Washington.....	LEE M. HUTCHINS
Washington Section, Society of American Foresters.....	WILLIAM A. DAYTON
Washington Society of Engineers.....	CLIFFORD A. BETTS
Washington Section, American Institute of Electrical Engineers.....	A. H. SCOTT
Washington Section, American Society of Mechanical Engineers.....	RICHARD S. DILL
Helminthological Society of Washington.....	L. A. SPINDLER
Washington Branch, Society of American Bacteriologists.....	ANGUS M. GRIFFIN
Washington Post, Society of American Military Engineers.....	FLOYD W. HOUGH
Washington Section, Institute of Radio Engineers.....	HERBERT G. DORSEY
District of Columbia Section, American Society of Civil Engineers	MARTIN A. MASON
District of Columbia Section, Society for Experimental Biology and Medicine	N. R. ELLIS

### Elected Members of the Board of Managers:

To January 1953.....	C. F. W. MUESEBECK, A. T. MCPHERSON
To January 1954.....	SARA E. BRANHAM, MILTON HARRIS
To January 1955.....	ROGER G. BATES, W. W. DIEHL

*Board of Managers*..... All the above officers plus the Senior Editor

*Board of Editors and Associate Editors*..... [See front cover]

*Executive Committee*.... WALTER RAMBERG (chairman), F. M. SETZLER, H. S. RAPPLEYE, WILLIAM A. DAYTON, F. M. DEFANDORF

*Committee on Membership*... E. H. WALKER (chairman), M. S. ANDERSON, CLARENCE COTAM, R. C. DUNCAN, JOHN FABER, G. T. FAUST, I. B. HANSEN, FRANK KRACEK, D. B. JONES, E. G. REINHARD, REECE I. SAILER, LEO A. SHINN, F. A. SMITH, HEINZ SPECHT, H. M. TRENT, ALFRED WEISSLER

*Committee on Meetings*.... H. W. WELLS (chairman), WM. R. CAMPBELL, W. R. CHAPLINE, D. J. DAVIS, H. G. DORSEY, O. W. TORRESON

*Committee on Monographs* (W. N. FENTON, chairman):

To January 1953.....	R. W. IMLAY, P. W. OMAN
To January 1954.....	S. F. BLAKE, F. C. KRACEK
To January 1955.....	W. N. FENTON, ALAN STONE

*Committee on Awards for Scientific Achievement* (J. R. SWALLEN, general chairman):

*For Biological Sciences*..... J. R. SWALLEN (chairman), L. M. HUTCHINS, MARGARET PITTMAN, F. W. POOS, L. P. SCHULTZ

*For Engineering Sciences*..... R. C. DUNCAN (chairman), A. C. FIELDNER, WAYNE C. HALL, J. W. MCBURNEY, O. S. READING, H. L. WHITTEMORE

*For Physical Sciences*..... L. A. WOOD (chairman), P. H. ABELSON, F. S. DAFT, GEORGE W. IRVING, JR., J. H. McMILLEN

*For Teaching of Science*..... M. A. MASON (chairman), F. E. FOX, M. H. MARTIN

*Committee on Grants-in-aid for Research*..... L. E. YOCUM (chairman), H. N. EATON, K. F. HERZFELD

*Committee on Policy and Planning:*

To January 1953.....	W. A. DAYTON (chairman), N. R. SMITH
To January 1954.....	H. B. COLLINS, JR., W. W. RUBEY
To January 1955.....	L. W. PARR, F. B. SILSBEE

*Committee on Encouragement of Science Talent* (A. T. MCPHERSON, chairman):

To January 1953.....	A. H. CLARK, F. L. MOHLER
To January 1954.....	J. M. CALDWELL, W. L. SCHMITT
To January 1955.....	A. T. MCPHERSON, W. T. READ

*Representative on Council of A. A. A. S.*..... F. M. SETZLER

*Committee of Auditors*..... C. L. GAZIN (chairman), LOUISE M. RUSSELL, D. R. TATE

*Committee of Tellers*... GEORGE P. WALTON (chairman), GEORGE H. COONS, C. L. GARNER

## CONTENTS

	Page
BOTANY—Notes on <i>Fraxinus</i> (ash) in the United States. ELBERT L. LITTLE .....	369
PALEONTOLOGY.—Taxonomic notes on genera of fossil and Recent Bryozoa. R. S. BASSLER .....	381
ZOOLOGY.—The larva of <i>Hymenolepis californicus</i> in the brine shrimp ( <i>Artemia salina</i> ). R. T. YOUNG .....	385
HELMINTHOLOGY.—Helminths from the Republic of Panama: II: A new trematode from the intestine of <i>Philander laniger pallidus</i> Thomas and key to the species of the genus <i>Phaneroopsolus</i> Looss, 1899 (Trematoda: Lecithodendriidae). EDUARDO CABALLERO Y C. and ROBERT G. GROCOTT .....	388
MAMMALOLOGY.—A new name for <i>Dipodomys ordii fuscus</i> Setzer. HENRY W. SETZER .....	391
OBITUARY: Albert Eugene McPherson .....	391
INDEX TO VOLUME 42 .....	392













SMITHSONIAN INSTITUTION LIBRARIES



3 9088 01303 1935