

With the Compliments
of the Authors

BULLETIN
OF THE
PUBLIC MUSEUM OF THE CITY OF MILWAUKEE

Vol. 3, No. 1, pp. 1-138, plates 1-19, figs. 1-19

October 31, 1919

The Kratz Creek Mound Group

A Study in Wisconsin Indian Mounds

BY

S. A. Barrett and E. W. Hawkes



MILWAUKEE, WIS., U. S. A.
Published by Order of the Trustees



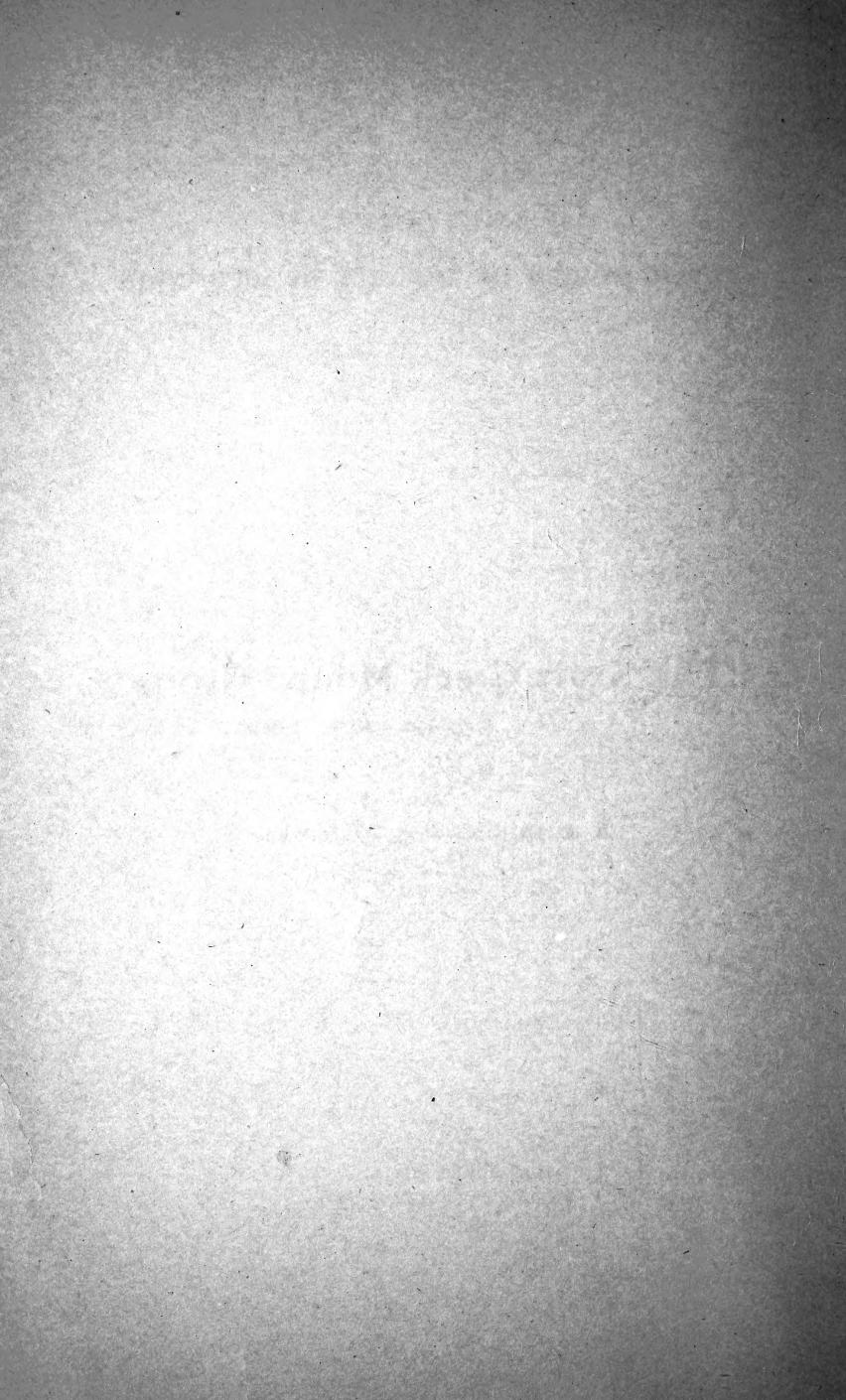

BULLETIN
OF THE
PUBLIC MUSEUM OF THE CITY OF MILWAUKEE

Vol. 3, No. 1, pp. 1-138, plates 1-19, figs. 1-19

October 31, 1919

The Kratz Creek Mound Group
A Study in Wisconsin Indian Mounds

BY

S. A. Barrett and E. W. Hawkes

MILWAUKEE, WIS., U. S. A.
Published by Order of the Trustees

E74
W8B27
copy 2
[Vol. III.]

Printed at
THE NORTH AMERICAN PRESS
Milwaukee, Wis.

Engravings by the
HAMMERSMITH-KORTMEYER CO.
Milwaukee, Wis.

E32999.



THE KRATZ CREEK MOUND GROUP

CONTENTS

	Page
Preface	8
Introduction	10
The Buffalo Lake Region	12
The Kratz Creek Mound Group	13
Arrangement of Mounds	13
Forms of Mounds	14
Materials of Mounds	15
Construction of Mounds	16
Uses of Mounds	21
Sacrifices	21
Deposition of the Dead	23
Cremation	24
Burial	25
Flexure	26
Burials of Partly Cremated Remains	27
Bundle Re-Burials	27
Intruded and Intrusive Burials	28
Artifacts	29
Probable Age and Affiliation	31
Detailed description of the Mounds	35
A Conception of the History of the Kratz Creek Mounds	92
Summary	99
Conclusion	100

ILLUSTRATIONS

Plates

- Plate I. fig. 1. The mouth of Kratz creek.
fig. 2. Buffalo lake.
- II. Panorama of Buffalo lake, taken from a point a short distance west of the Kratz creek mound group.
- III. Cross section of the large conical burial mound No. 1, showing stratification.
- IV. Cross section of the panther effigy mound No. 3, showing the stratification of the shoulder position.
- V. figs. 1, 2. Burials in the panther effigy mound No. 3.
- VI. The panther effigy mound No. 5, showing the body of the mound stripped of the sod.
- VII. fig. 1. The body of the panther effigy mound, No. 5, stripped of sod. Also mound No. 7 in the foreground.
fig. 2. The panther effigy mound No. 3, after its excavation.
- VIII. Cross section of the central part of the body of the bear-panther effigy mound No. 5, showing stratification and "intruded" burial.
- IX. fig. 1. An altar in the panther effigy mound No. 3 showing partly cremated human bones.
fig. 2. A pocket of golden ceremonial sand in the panther effigy mound No. 3.







- X. fig. 1. A large crematory altar (No. 5) in the conical burial mound No. 1. This altar shows fragments of charred human bones.
- fig. 2. A repository altar (No. 4) of peculiar form in the conical burial mound No. 1.
- XI. figs. 1, 2. Repository altars (Nos. 2 and 1) in the conical burial mound No. 1.
- XII. fig. 1. A partially cremated skeleton in the small conical mound No. 8.
- fig. 2. The remains of a cremated skeleton in the rabbit effigy mound No. 9.
- XIII. fig. 1. The large conical burial mound No. 1, partly excavated.
- fig. 2. Kratz point upon which most of the mounds of the Kratz creek group are located.
- XIV. figs. 1, 2. The large ossuary of bundle re-burials found in the center of the conical burial mound No. 1.
- XV. figs. 1, 2. The large ossuary of bundle re-burials found in the center of the conical burial mound No. 1.
- XVI. fig. 1. Skeleton of a burial in the flesh (No. 2) found in the large conical burial mound No. 1.
- fig. 2. Skeleton of a burial in the flesh (No. 3) found in the large conical burial mound No. 1. This skeleton had five quartzite arrow points placed about its right knee.
- fig. 3. The right knee of the skeleton shown in fig. 2 with the five quartzite arrow points in place.
- XVII. fig. 1. Surveying the Kratz creek mound group.
- fig. 2. General view of the excavation of the large conical burial mound No. 1.
- figs. 3, 4. Methods of excavating the ossuary of bundle re-burials in the large conical mound No. 1.

- .XVIII fig. 1. Crematory altar associated with pottery in a small conical burial mound No. 50, in the Kratz Creek group.
- fig. 2. Fragmentary remains of a pot accompanying the crematory altar shown in plate IX, fig 1, found in the panther effigy mound No. 3.
- XIX. Three views of the right lobe of the pelvis of a man with a quartzite arrowhead imbedded in it. This came from the bottom of the mass of bundle re-burials in the center of mound No. 1.

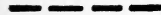
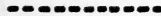
Text Figures

- Figure 1. Plan of the Kratz creek mound group.
2. Plan of the conical burial mound No. 1.
 3. Plan of altar No. 4, mound No. 1.
 - 4a. Horizontal plan of altar No. 5, mound No. 1.
 - 4b. Vertical section of altar No. 5, mound No. 1.
 5. Plan of panther effigy mound No. 3.
 6. Cross section of the tail of mound No. 3.
 7. Cross section of the present conical end of the tail of mound No. 3.
 8. Plan of effigy mound No. 4.
 9. Plan of bear-panther effigy mound No. 5.
 10. Cross section of the fore foot of mound No. 5.
 11. Plan of rabbit effigy mound No. 9.
 12. Plan of conical-ended linear mound No. 12.
 13. Plan of conical mounds Nos. 13 and 14.
 14. Plan of conical mounds Nos. 31 to 33.
 15. Plan of bear effigy mound No. 34.
 16. Plan of bear effigy mounds Nos. 35 and 36.
 17. Plan of panther effigy mound No. 38.
 18. Plan of eagle effigy mound No. 39.
 19. Plan of effigy mound No. 40.

Key to Lines and Characters Used in Figures

	Mound delineations. Used in horizontal plans and also in elevations.
	Doubtful mound limits. Used when the mound is located in a ploughed field or its limits are otherwise rendered doubtful.
	Used in elevations to indicate the surface level of the surrounding land.
	Limits of intaglio excavations.
	Sections of mounds excavated in the present work.
	Borings.
	Limits of fireplaces or strata.
	Fireplaces.
	Skeletons.

PREFACE

Early in the summer of 1917 the Board of Trustees of the Public Museum of the City of Milwaukee directed its Department of Anthropology to survey and excavate a group of mounds in Wisconsin. Upon the recommendation of Trustee George A. West, himself the author of several valuable works on Wisconsin archeology, a preliminary reconnaissance was made of the shores of Buffalo lake, in Marquette County, on June thirteenth and fourteenth. Mr. West's judgment concerning the desirability of choosing this region as a site for excavations was amply justified by the wealth of aboriginal remains which were found.

After a cursory investigation of these shores two sites were selected as the most favorable. One of these was the large group located on the Neale farm on the south shore of the lake and directly opposite the town of Packwaukee. The owners, Messrs Samuel R. and William H. Neale, very kindly consented to allow the survey and excavation of this site. As matters developed this was impossible in the time available but it is hoped that this work may be done later.

The second site is what is known as the Kratz Creek group. This is located largely on the property of Mr. Ferdinand Kratz, who very generously gave his consent to its excavation. The west end of this group lies on property belonging to Mr. L. J. Dartt, to Mr. G. Zarbrook and in the county highway. Mr. Dartt very kindly permitted excavations to be conducted on his property, while the four mounds on the Zarbrook premises were only surveyed.

On July sixteenth our party left Milwaukee for the Kratz Creek site, equipped with all necessary tools for excavating and with the requisite instruments for making a careful survey.

The party comprised four members of the department: Mr. J. A. Jeske, Mr. W. O. Johnson, and the two authors.

First a very careful survey was made with the transit and an adequate cross section system of stakes was established. From these the reckonings, both horizontal and vertical, were made as

each step in the work progressed. Careful notes and plats were made showing forms, and stratifications of mounds, as well as exact locations of burials, altars, etc.

This survey was greatly facilitated by the fact that the United States government engineers of this district were at the time engaged in a detailed survey of the Fox river and had recently placed one of their concrete monuments (U.S.P.B.M. 172) in the edge of this mound group. With this as a base from which to reckon, our survey was made much easier. We are indebted to the district engineer, Mr. J. A. B. Tompkins of Milwaukee, for the following information, under date of Oct. 20, 1917, concerning this monument and the lake:

Latitude, $43^{\circ}-46'-32.3''$ N.

Longitude, $89^{\circ}-23'-7.2''$ W.

Elevation, 776.52' above M. T. at New York City.

The extreme high, extreme low, and mean, stages of Buffalo lake are as follows:

Extreme high, June 24, 1888, was 775.7' above M. T. at New York City.

Extreme low, August 25, 1894, was 769.3' above M. T. at New York City.

Mean for the last 41 years is 771.2' above M. T. at New York City.

The excavating of the skeletal remains was attended with much difficulty, owing largely to their extreme age and decomposition. In practically every case they had the consistency of soft cheese. They were in fact usually softer than the surrounding earth or sand. This necessitated the utmost care and the use of such delicate instruments as the painter's dust brush, and the palate knife, in addition to the usual trowel and whisk broom.

Such was the condition of these bones that it was usually necessary to treat them with an infusion of a hardening liquid before their removal, or at least to leave them exposed to the air for some hours. In a few cases they were so far gone that a plaster cast was necessary to save them at all.

In spite of this extreme care in their removal the bones were recovered in a very fragmentary condition. This, combined with

the fact that no opportunity has as yet presented itself to study and measure these remains, makes a detailed discussion of them impossible at present.

The work at this site continued until September fifteenth, during all of which time the party was accorded the most kindly consideration by the people of the entire region. Thanks are especially due to Mr. L. J. Dartt, whose inherent interest in such matters caused him to devote many spare hours and even whole days at a time to assisting in the excavating. Thanks are also due to Mr. Towne L. Miller and Mr. Charles Lamb of Ripon, who paid the camp two short visits and who assisted us materially on both occasions.

This work at the Kratz Creek group is the initial step by the Public Museum in what it is hoped will develop into a systematic series of excavations of typical mound groups and other archeological remains in Wisconsin.

INTRODUCTION

In offering this discussion of the survey and excavation of the Kratz Creek group of mounds we wish to call attention to certain special features which may prove of value in the study of mound problems elsewhere.

While many surface surveys and a certain amount of excavating have previously been done by members of the Wisconsin Archaeological Society and by various other individuals, no intensive survey and excavation with the aid of surveying instruments and with special attention to stratification have been conducted in recent years¹ in this state². The need for such work is especially apparent when we consider that in Wisconsin are located almost the only effigy mounds³ known, and that these show a great variety of forms.

There are many purely theoretical conceptions concerning the origin, construction and purposes of mounds, especially those of

1 The splendid pioneer work of Dr. I. A. Lapham as recorded in his *Antiquities of Wisconsin*, Washington, 1855, should be here mentioned.

2 Similar methods have been employed elsewhere, particularly by Professor W. C. Mills in Ohio, where somewhat similar mound problems exist.

3 The great serpent effigy in Ohio and certain others are the most notable exceptions.

effigy forms. Certain of them are quite incorrect. To obtain the best result it is, therefore, highly important to enter this field of investigation with no preconceived ideas, but to allow the excavation itself to tell its own story.

While too general an application should not be made of our findings in the Kratz Creek work there are certain facts which appear to be so fundamental that they may be profitably applied to other mound groups in the state. These are:

1. The mounds of a large group are usually arranged in some definite order, often with reference to the nearest water course or some other physiographic feature. This has been repeatedly shown in mound surveys in various parts of the state.

2. Although mounds may differ widely in construction they are usually not "heaped up" at random on the surface of the ground, but are most often built with a systematic plan. In certain cases at least, a definite, careful stratification is present. Such stratification of mounds is shown by the work of various Wisconsin investigators, though it has been often overlooked.

3. The form of a mound does not necessarily indicate its use. Effigy mounds as well as conicals were used for burial purposes, as shown especially in the present work. Similar uses of effigy mounds have been previously reported.

4. Elaborate ceremonial procedure attended the construction of mounds as well as the disposition of the dead contained in them. This is shown by the frequent occurrence of fire strata and sacred earths, and by evidences of unburned offerings in the mounds of this group. This fact was recognized by the pioneer Wisconsin archeologist, Dr. I. A. Lapham⁴, who was the first to survey and describe Wisconsin mounds.

⁴ In speaking of the earthworks at Aztalan, he says: "From the oft repeated indications of fire at various depths, we could draw no other conclusion than that this was a mound of 'sacrifice', and that at each repetition of the ceremony an addition was made to the height of the mound."—*Antiquities of Wisconsin*, p. 48, Washington, 1855.

THE BUFFALO LAKE REGION

Buffalo lake is a section of the Fox river in which the water has been impounded by means of a dam at Montello⁵, thus producing a lake about twelve miles long and from one-sixth to one-half a mile in width. It is located in Marquette county, in central Wisconsin, and is a relatively shallow body of water which still shows certain of the characteristics of the old landscape, plate I, fig. 2, and plate II.

Formerly this was a great wild rice marsh, with a relatively small stream meandering through its middle and flanked on either side by fairly high banks. These immense fields of that important Indian food of the Great Lakes region, the wild rice, together with the fish and water fowl, which formerly abounded in the stream and marsh, as well as the limitless game in the adjacent forest, must have produced a food supply sufficient to provide an easy and abundant living for a very large population. These favorable conditions allowed ample time for an elaborate ceremonial life and for the construction of the great earth works which we now find.

Furthermore, the Fox river was probably in those days, as in early historic times, one of the principal lines of communication between the Mississippi Valley tribes and the copper mines of northern Wisconsin and the Michigan peninsula. Along such a thoroughfare should be found many remains of former occupations, both of resident tribes and probably traces also of visiting tribes or delegations enroute for purposes of trade, to attend inter-tribal councils, or on religious pilgrimages. This conclusion is borne out by the presence all along the shores of this former marsh of camp sites, village sites, work shops, pottery making sites, fields, and especially of hundreds of mounds. In fact it is doubtful if there is any other like area, at least in Wisconsin, where so many mounds, and of such diverse forms, are found⁶. These and the numerous sites are associated in such a manner as to show at least two and possibly a larger number of more or less distinct occupations, probably extending over a long period of time.

⁵ This dam was started by the Fox and Wisconsin Improvement Company in 1856. It was abandoned by that company in 1857 and nothing more was done with it until 1868, when it was finally completed by the Green Bay and Mississippi Canal company. On Sept. 18, 1872, it was purchased by the federal government and now forms part of the inland water way system connecting the Great Lakes and the Mississippi river.

⁶ There is now in preparation a detailed surface survey of the aboriginal remains along the shores of this lake.

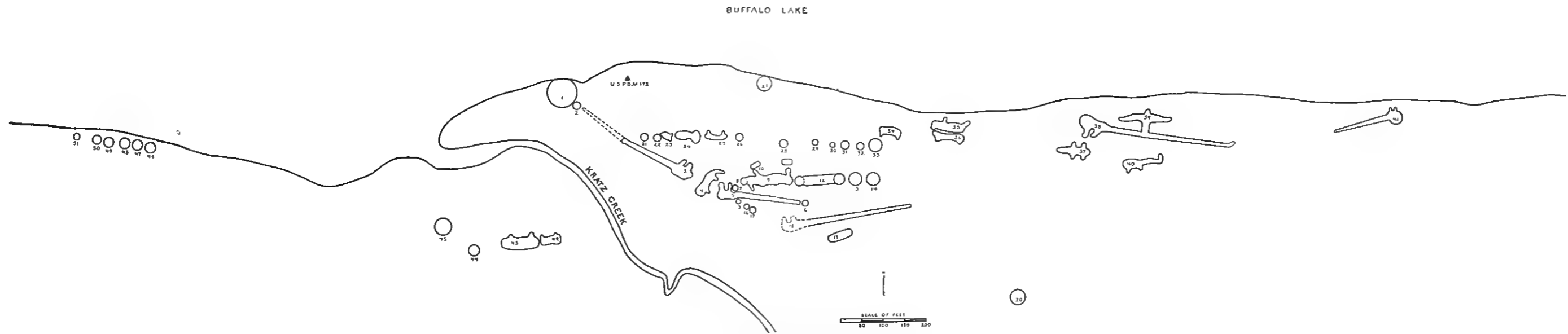

FIG. 1—PLAN OF THE KRATZ CREEK MOUND GROUP

Most of these mounds are arranged systematically in definite groups. One of the largest and most important of these is the Kratz Creek group, shown in figure 1, the exploration of which forms the subject of this paper.

THE KRATZ CREEK MOUND GROUP

The Kratz Creek group of mounds is located on both banks of Kratz creek, plate I, fig. 1, a small stream flowing from the south into Buffalo Lake. It consists of fifty-one mounds of three general types, effigy, linear and conical, arranged in certain definite groupings along the brow of the elevated south shore of the lake.

The principal body of these mounds is on what is known as Kratz Point, a prominent projection just east of the creek itself, and which commands an unobstructed view for several miles up and down the lake.

Buffalo lake is about midway between the Fox-Wisconsin portage and Lake Winnebago, while Kratz Point is about midway of the lake itself, and was in aboriginal times well wooded and had two good springs immediately adjacent. These features, combined with the commanding outlook of the point, and the abundance of the natural resources of the region made it a favorable location for Indian assemblages. No more ideal spot could have been chosen for ceremonial gatherings, councils or other important tribal or inter-tribal meetings.

That this point was so considered by the builders of the mounds themselves is shown by the presence of the very large conical mound (No. 1) located on the immediate point itself, and on which most of the mounds of the rear line of the group appear to bear.

ARRANGEMENT OF MOUNDS

The general arrangement of these mounds, and the relations in which they stand one to another should be first considered. These are shown in the plat of the group given in text fig. 1. They, as a whole, appear to be arranged with definite reference to the lake, being placed in lines more or less parallel to its shore.

Along the immediate shore is a fairly continuous line of mounds of various types which, as will be later shown, appear to antedate a

second line farther back. Thus from a purely chronological standpoint the group may be subdivided into these two sections.

In relation to the topography of the site itself the group may be divided into four smaller units, as follows:

1. The main sub-group is located east of the mouth of Kratz creek, between it and a small ravine about twelve hundred feet distant. It is the largest section and consists of thirty-six mounds of various forms. At some distance from this sub-group is the detached conical No. 20.

2. The second sub-group lies east of the ravine and consists of five effigy mounds.

3. The third sub-group is immediately west of the creek and consists of four mounds.

4. The fourth sub-group, consisting of six conical mounds, is situated a considerable distance to the west of the creek and immediately along the bluff at the lake shore.

In each of these sub-groups the mounds appear to be arranged in a definite interrelation. As above mentioned, those of the main sub-group are disposed in straight lines, each line bearing almost directly on the large conical mound, which occupies the dominating position on Kratz Point itself.

The conical mounds in sub-group No. 1 are distributed chiefly in lines of three, each set being relatively close together⁷. From conditions observed in other groups as well as in this one it appears that these may be but outlines of unfinished linear or effigy mounds, which would have been completed by filling in the spaces between them.

FORMS OF MOUNDS

In the Kratz Creek group, there are, as has already been mentioned, mounds of three general forms: conical, linear, and effigy. The conical mounds vary according to construction and use, rather than in form.

The linear mounds are relatively few and unimportant, but we may recognize the simple linear and the conical-ended linear types. The latter is probably, as above suggested, a composite mound, produced by filling in the space between two or more conicals placed in a line.

⁷ Dr. Cyrus Thomas, says: "the custom of placing the small tumuli in lines connected and disconnected to form the long wall-like mounds seems to have been peculiar to the builders of the effigies."—*Mound Explorations*, Ann. Rept., Bur. Amer. Ethn. XII, p. 709.

The effigy is the most important form of mound in this group, and occurs in several types, as shown in figures 1, 5, 8, 9 and 15-19. These mounds have been rather loosely named in the past after certain animals on account of similarities of form. In this group are several panthers, several bears, one bird, one lizard, and one of a form which for convenience is here termed a "rabbit" mound. The doubtful advisability of attaching names of animals to such mounds when the similarity of the mound form to that of the animal is only relative, will be sufficiently apparent from a consideration of the mounds in this group alone. However, since these names have come into general use, it seems best to retain them in this discussion.

In fact, if the aboriginal builders of these mounds did intend to depict certain animals there is, in many instances, an interesting naiveness of treatment suggestive of the artistic ideas of a child. Having once established a pattern of the panther, bear or other animal form they repeated its general outline with almost stereotyped faithfulness. However it was often varied in minor details and somewhat distorted and frequently was embellished with extra legs, ears or other appendages, misplaced in relation to the rest of the animal.

While some attention must be given to the possibility of odd forms originating from mythological concepts it seems likely that this form of art was entirely realistic in its essential features and it is probable that any apparent anomaly in form is due rather to this child-like distortion than to an attempt to depict a composite or a mythical animal. In fact, this absence of composite forms is quite in keeping with the religious and mythological concepts of the Indians of the Central Algonkian region. The striking absence of more elaborate geometric mound forms, such as exist in the Ohio valley, may be due to the fact that the artistic conceptions of the builders of these mounds, like those of the present day Indians, were essentially realistic.

MATERIALS OF MOUNDS

A popular notion concerning mounds is that they were entirely constructed of local materials obtained in the immediate vicinity. This assumption is only partly correct so far as the mounds in this group are concerned. While a large amount of the material used

was undoubtedly obtained from the vicinity, our excavations show that, in many instances, special earths, evidently sacrificial, were brought from considerable distances, and interspersed with the strata of local earths.

The sacred earths were placed, usually under or surrounding burials, and as special sacrificial strata between ceremonial fires; also around altars and about animal remains buried in the mounds, presumably as sacrifices. They were of four kinds: a fine, light yellow, sandy loam; a golden sand; a brick red sand; and red clay. The contrasts between these highly colored strata and those of the somber local earths with which they were interspersed was one of the most striking features of these excavations. These contrasts may be seen in plate IX, fig. 2, where a photograph of a pocket of this golden sand is shown. Also plates III, IV, and VIII show the stratification of three of the most important mounds of this group, indicating the colors of the various materials used in their construction. Although this use of special sacred earths or sands is found in certain other sections of America it is certainly an anomaly in this northern region.

Further, the mounds show strata of fire blackened earth, charcoal and ashes, as well as evidences of decomposed organic matter. These point to the celebration of elaborate ceremonies in which burnt sacrifices and unburned offerings of effects were placed in the mound during its construction. While these strata of sacred earths, unburned offerings, and fire remains form the minor portion of the materials of most of the mounds they were doubtless considered to be of the highest importance by these builders. In fact, in certain mounds, particularly in those devoted to cremation and burial, they often actually form the major part of the contents.

CONSTRUCTION OF MOUNDS

Although it is often popularly presumed that mounds are simply piles of earth heaped up on the existing surface of the ground, careful investigation will probably show that this is rarely the case in Wisconsin except in very recent mounds. Our excavations in the Kratz Creek group have clearly demonstrated that these mounds are in most cases quite complex in their structure.

The only exception is a class of small conical mounds, apparently unfinished. These are very low, flat-topped mounds, contain-

ing only a single artificial layer of earth. They were probably destined to receive other strata when utilized for burial, crematory or sacrificial purposes at some future date.

Further, the conical may have been employed as a delineator in building larger mounds. This is shown by the fact that often small conical mounds are grouped in such positions as to suggest that they may have been intended as "markers" to outline effigy forms. Also, certain effigy mounds appear to have been constructed by actually filling in the intervening spaces between such delimiting conicals. This is shown by the fact that in some completed effigies the shoulder, hip and head positions, and often the feet and tip of the tail, show distinctly circular forms and sometimes even an elevation similar to the rounded top of a conical. Often these conically shaped sections show special and independent stratification. Again, the conical ended linear points conclusively to the use of the conical to mark the limits of this larger mound structure.

The linear mounds of the group were relatively simple in construction. The conical ended linear, No. 12, showed the usual elaborate stratification in the conicals themselves, but was quite simply constructed in the connecting linear section.

The finished conical mound usually shows more or less stratification depending upon the purpose for which it was built. Certain of these conicals, as No. 27, consisted almost entirely of a thick fire stratum underlaid by a thin stratum of sacrificial earth, showing that it was probably used as a great funeral pyre or crematory altar. Some are relatively simple in construction though devoted to other uses. Certain conicals contain several strata, together with pockets of sacrificial earths and also altars. In the larger conicals, such as No. 1, are often found very elaborate stratigraphic structures consisting of successive layers of local and sacrificial earths interspersed with fire strata and all reared over elaborate burials.

In constructing the conical mounds, as also the effigies and linears, the builders invariably removed the black surface soil, a fact which was noted by Lapham at Aztalan as early as 1850⁸. An explanation of this custom may be found in the possible desire of the

⁸ He says: "The builders had carefully removed the black soil before they commenced the erection of this mound." *Op. cit.* p. 44.

builders to be rid of any pollution which might be conceived to be attached to the surface soil, before starting the bed of sacred earths upon which to place the remains of the deceased.

Frequently the excavation extended several feet below the surface of the surrounding land, sometimes going down as far as the clay subsoil. This excavation was then carefully filled in with sacrificial earths upon which the burial, crematory altar, or other special feature was placed. This custom of excavating fairly deeply the bottom of such a mound may have arisen through the necessity of providing ample vertical space for the elaborate stratification required by the ceremonial procedure of these people.

This practice of excavating the bottom of a mound is even more strikingly shown in the construction of the effigy mounds. In fact, perhaps the most important development in the work on this mound group is the discovery that in certain instances the builders of these effigies first made an excavation of approximately the same animal form as the mound itself and extending to a considerable depth below the surface of the surrounding earth. They then built, stratum upon stratum, with much ceremony, as was indicated by the successive strata of sacrificial earths and fires, the mound which we now find reared above the surface of the ground. This we may consider as a cameo above the original excavation which has been termed an intaglio. (See plate IV and fig. 5.)

In filling in an intaglio excavation, or in fact in constructing almost any type of mound in this group it was built up, with various layers of ceremonial earths, common soils, and fire blackened strata. Indications point to the fact that a considerable time may have elapsed, at least in some instances, between the construction of one stratum and the placement of the one next succeeding it. It is possible, in fact, that such a mound may have required a considerable period of years⁹ for its completion, and that each stratum of fire blackened earth may mark a ceremonial cycle in the construction of the mound. An analogous mortuary custom is found in the annual mourning ceremonies of certain Pacific coast tribes which are even yet celebrated¹⁰. In accordance with the usual aboriginal psychology this seems to be a more likely mode of procedure than that a large number of individuals should go and build such a huge earth

⁹ See footnote 4.

¹⁰ The annual mourning ceremony of the Maidu is described by Dr. R. B. Dixon in Bull. Amer. Mus. Nat. Hist., Vol. XVII, part 3, pp. 245-259, 1905. Similar ceremonies are celebrated among the Miwok and certain other California tribes.

work in a few days or weeks without any particular ceremonial observance. In other words there is every reason to believe that the builders of these mounds went about this task with the same ceremonial and ritualistic circumspection that would characterize the methods of the present day Indians were they to undertake such a work in connection with the disposition of their dead.

From the evidence found in the Kratz Creek group, it would appear that the several intaglios formerly in this state, were apparently only unfinished panther mounds¹¹. The most striking instance of an intaglio being used as the foundation for a cameo is that of the panther mound, No. 3, shown in figure 5, in which the excavation extended from about two feet below the surrounding surface at the head of the mound to a few inches below the surface at its tail. This excavation had practically the same form, and approximately the same size as the finished mound. The shoulder position of this mound held three very carefully placed burials, showing its definite purpose. These are illustrated in plate V. The shoulder and hip positions were considerably deeper than the remainder of the body, which was in turn deeper than the legs and tail. In substantiation of the theory that the intaglio was used regularly as a base for the cameo it should be noted that the Fort Atkinson panther intaglio shows precisely this same condition and was in all probability to be filled in and finished as were the panthers of the Kratz Creek group had the work not been interrupted.

In another instance, that of the "rabbit" mound, No. 9, shown in figure 11, a fairly deep excavation at either end decreased in depth to about zero at the middle of the mound, producing what we may term a half intaglio form as its foundation. These deeper excavations at the two ends held burials.

Still another and perhaps even more interesting mound structure is that of the panther effigy, No. 5, shown in figure 9, in plate VI and in plate VII, fig. 1. As has been mentioned, in this mound the original excavation or intaglio was in the form of a bear and much smaller than the superposed panther. The stratification here showed that this original bear intaglio had been filled in with carefully placed strata to a point very slightly above the level of the surrounding land, producing perhaps a mound like one of the low bear forms found in other parts of this group.

¹¹ Nine such intaglio structures, all of them of the panther form, are on record. All of these have been destroyed except one which is now preserved as a state park at Fort Atkinson, Wisconsin.

At a later time it was completely covered by a large panther effigy, which was simply superposed upon it with only a slight extension of the original bear cameo into that of a panther body. Thus in this instance we have an original bear intaglio and cameo used as a foundation for the later panther effigy which is built almost entirely above the level of the surrounding surface.

In addition to this vertical change due to the superposition of one mound form upon another there is another change in horizontal structure in which different sections of the same mound may show quite different methods of construction. Mound No. 3 is one in which the stratification definitely changed toward the rear of the body of the panther and continued on down the tail. In this mound the original form, perhaps left unfinished for some time, was simply completed, probably by the same people who started it. In the case of mound No. 5, on the other hand, it seems most likely that the change of form from the bear to the panther was effected by a later people.

The presence of the intaglio "foundation" in these several mounds, both conical and effigy, affords an explanation of the intaglio problem and one which may be of rather wide application. As above mentioned, only nine panther intaglios are on record. If these were intended as finished products and were an established separate form we would doubtless find among the thousands of earth works in Wisconsin many more such excavations. From the present work it seems highly probable that these are simply unfinished mounds which were destined to be reared as cameos. The work of the builders may have been suddenly interrupted or it is possible that the mounds took, as above suggested, two or more seasons for completion.

In either case the work may have been suspended after this initial step by any one of the many vicissitudes to which such primitive builders must have been subjected. They may have been driven away by hostile tribes, pestilence may have suddenly come upon them, some taboo may have been suddenly placed on the site, or a worker may have violated some fixed rule in respect to the construction. These and various other causes which will readily suggest themselves to the student of aboriginal life would be considered sufficient by the primitive builders to interrupt the work.

USES OF MOUNDS

It seems to be quite generally assumed that in Wisconsin conical mounds only were devoted to burial purposes while effigy mounds contain no burials save now and then an intrusive one. The work in this group of mounds, however, has quite clearly shown that the form of the mound does not predicate its use, since burials were found in the conical-ended linear, and in the effigies, as well as in the true conicals.

These various types of mounds were used for four general purposes: burial, cremation, burnt sacrifice, and deposition of offerings. The mounds of each type usually contained some evidences of each of these uses, although certain types appear to have been more specifically devoted to special purposes, as outlined below.

The conical mounds were used as:

1. Burial and sacrificial mounds for interments in the flesh and for re-burials probably from original tree or scaffold burials.
2. Crematories for human remains.
3. Repositories for unburned offerings; altars where many perishable objects, animal sacrifices and a few stone implements were placed.
4. Repositories for crematory altars where sacrifices of animals, goods, and possibly human beings were offered.

The linear mounds of this group are relatively simple in construction and use. Some evidence of their sacrificial use, however, was obtained in connection with the burials above cited in the conical-ended linear.

The effigy mounds in almost all cases, show evidence of their use for mortuary or for sacrificial purposes and in most instances for both.

Each burial mound in this group, regardless of form, has an in-taglio foundation, which is filled with one or more strata of sacrificial earth.

SACRIFICES

The paramount importance of sacrifices in the religion of the builders of these mounds is clearly evident from the abundant remains of fires and altars of various kinds, a fact which seems to have been often overlooked in previous mound work.

In the Kratz Creek group of mounds six classes of sacrifice were found:

1. The use of sacrificial earths, which was the most common.
2. The sacrifice of perishable property, either deposited or cremated, which was also very common.
3. The sacrifice of food stuffs in pottery vessels, which was rather rare.
4. The animal sacrifice, also rare.
5. The sacrifice of implements, including archaic points, which is found to a very slight extent.
6. The human sacrifice, which seems to have been used in a few instances. See plate IX, fig. 1, and plate X, fig. 1.

These various sacrifices were placed:

1. With the burial itself; below, around, or directly above it.
2. Between successive strata as the mound was constructed.
3. Upon special altars.
4. Upon the surface of a mound, and especially as burnt offerings in the great surface fire which often marked the completion of such a mound¹².

It is evident from the above that the two most important elements of sacrifice used by these mound builders were the sacrificial earths and sacrificial fires. The close correlation and association of the two in their religious ceremonies is shown by the fact that they were placed as alternate strata in the construction of nearly all the mounds. Further, most of the mounds, particularly those with *in-taglio* foundations, were begun with one or more layers of these special sacrificial earths as a ceremonial foundation and were finished with a great ceremonial fire.

Both were associated directly with burials, being placed under, around, or directly over them. In several mounds there were four layers of each alternating regularly above the burial.

In one instance a distinct fire ring was found encircling a burial. No corresponding rings of sacrificial earth were encountered in this mound, though in mound No. 1 a comparable ring of earth was found encircling the entire burial pit and altars of the mound.

In another instance there had been a series of small fires arranged in a circle slightly above a burial and outlining its position, while in still another several small fires were placed in a line at

¹² As previously mentioned certain mounds were themselves special sacrificial altars used solely for the deposition or cremation of sacrifices.

equal intervals along the top of a mound. Detached pockets of ceremonial earths were found in several of the mounds, though no circle or line of such pockets was observed.

At frequent intervals throughout the mound strata are interspersed thin layers of discolored earths which indicate the presence of decomposed organic matter. These are probably the remains of considerable sacrifices of goods which were deposited directly as offerings among the strata of sacrificial earths and fire layers. The fact that the goods deposited are now indicated by only this thin layer of discolored earth can not be taken as a criterion of their original quantity or value. Even to a greater extent is this true of the fire strata which doubtless represent the burning of great quantities of wood and large numbers of offerings.

One may well imagine the elaborate ceremonial procedure which accompanied the burning and deposition of these offerings, especially in connection with the great final fire overspreading the mound as a crowning ceremony celebrating its completion.

The extent of these fires in some mounds was phenomenal. In the case of the panther mound shown in fig. 5, the final fire covered a large part of the body, and extended throughout the length of the tail, a distance of about one hundred and eighty feet. Another panther mound, shown in fig. 17, was three hundred and sixty feet in length and had a fire extending for two hundred feet back over its body and along the tail. The eagle mound had a thick fire stratum covering its entire surface. The body was about fifty by twenty feet while its wings spread one hundred and twenty-five feet from tip to tip.

From these facts we must conclude that in building these mounds sacrifices played a most important role. They were frequently used from the very foundation of the mound to the crowning fire celebrating its completion. Also, the considerable number of types of sacrifices is unusual and the evidently great quantities in which they were employed are often extraordinary.

DISPOSITION OF THE DEAD

The most easily obtainable evidence concerning the disposition of the dead is of course found in the burials. It must not be assumed, however, that this was the predominant custom. The pres-

ence of the many fire strata in the mounds, of the various crematory altars, and of at least two large, special crematory mounds¹³, together with partly consumed human bones, indicates that human cremation was practiced, to some extent at least, and that it may have, during one period in the history of these mounds, been the prevailing custom.

CREMATION

The forms of cremation were:

1. Total cremation, which of course leaves no evidence at present.
2. Partial cremation, possibly for ceremonial purposes, as is evidenced by the subsequent burial of the partly burned remains with the usual strata of ceremonial earths and fires. Such a burial is illustrated in plate XII, fig. 1.

3. Human sacrifice. The assumption of human sacrifices is based upon the presence of partly consumed human bones on altars. These instances are shown in plate IX, fig. 1, and in plate X, fig. 1.

Total cremation is suggested both by the immense beds of ash and by other fire remains, and also by the presence of human bones so nearly consumed that they were almost in the form of ash. No evidence can obviously be obtained as to the purpose or extent of this total cremation, but the above mentioned thick layers of fire strata would suggest that it may have at one time been a prevalent custom here.

Several instances were found of partial cremation. These appeared to have been intentional and their purpose may have been ceremonial in nature. It appears that these individuals, whoever they may have been, were placed on a funeral pyre, or possibly on one of the adjacent crematory mounds. Here they were subjected to the partial action of fire, perhaps as a purification rite. The condition of the bones themselves indicates that it was probably not the intention to completely burn these bodies. None of these bones showed the almost complete consumption of those found on the crematory altars. They were apparently burned where the fire happened to strike that particular part of the body, thus completely consuming relatively small portions of it and leaving the re-

¹³ One of these mounds was thirty-two feet in diameter and about four and a half feet thick at its middle. It was composed almost entirely of a bed of charcoal and fire blackened earth.

mainder of the skeleton in as perfect condition as were the bones of regular burials in the flesh. Furthermore, these partly burned remains were buried with the same care and attended by the same ceremonial stratification as was customary with burials in the flesh. This lends color to the idea that this partial cremation was really a preliminary ceremony to burial in the flesh.

While the custom of human sacrifice is, as above stated, an assumption, and is impossible of absolute proof, it is very strongly suggested by the presence of partly burned human remains directly on altars. The partly cremated burials, on the other hand, were placed in separate positions in the mounds as were burials in the flesh. Further, in contrast to the carefully ordered deposition of the partly burned remains, was the disorderly appearance of these bones on the altars, evidently left as chance placed them. Such a condition would obtain in the burning of human sacrifices, such as slaves or prisoners of war, whose remains were not entitled to the respect paid those of a regular member or dignitary of the tribe.

Various possible explanations may be suggested for the occurrence of both cremation and burial in this group. Total cremation may have been reserved for a special class in the tribe. On the other hand, it may have been practiced by one of several tribes frequenting this locality, or by certain clans, while contemporaneously other tribes or clans practiced burial. Such divisions may have been descended from different peoples with widely varying customs. A third and more likely explanation may be found in the possible chronological succession of tribes in this locality practicing these two forms of disposition of the dead.

BURIAL

The forms of burial were five in number:

1. Burial in the flesh.
2. Burial of partly cremated remains.
3. Bundle re-burial in an ossuary.
4. Intruded burials.
5. Intrusive burials.

Original burials in conical mounds were, as a rule, near their centers, as shown in fig. 2. In effigy mounds, on the other hand, they were placed usually in the shoulder or sometimes in the hip position of the animal figure, as shown in figs. 5, 9, and 11.

All such burials were very carefully made with the association of fire and sacrificial earths as above noted. In several instances the earth immediately around the burial had been trampled or tamped very hard about the body when it was placed in position. From the condition of the bones, particularly those of the head, it would seem that such great pressure had been used in this tamping process that the bones had been displaced and in some cases even crushed. Notable examples of this type of burial are shown in plate V.

In practically all instances the skeletons faced toward the south and away from the lake. One exception to this rule was the burial shown in plate XVI, fig. 1, near the top of the conical mound No. 1. This skeleton was placed with the head toward the south and faced the lake. Judging from the somewhat better preservation of the bones and from other features it probably represents an intrusive burial of a later people. This was also the only skeleton lying on its left side. Another exception was the relatively recent burial shown in fig. 2 of this same plate. This also faced the lake, but lay on its right side. All the deeper burials were placed on the right side and faced toward the south.

These deeper burials were evidently usually those of high dignitaries since they were attended by much ceremonial stratification and frequently by what appears to be subsidiary burials. In effigy mound No. 3 the main burial was that of a middle aged man. He was placed in the center of the shoulder position of the mound, and on a carefully prepared stratum near the bottom level. This burial is shown in plate V, fig. 1. Very exactly placed at a higher level and in the relative positions shown in text fig. 5, were the two subsidiary burials shown in plate V, fig. 2. One of these was that of a middle aged man while the other was that of a very young woman.

FLEXURE

All skeletons buried in the flesh show flexure of the extremities. There were two types of flexure of the lower limbs. The skeletons in mound No. 1 have the legs sharply flexed, bringing the heels tightly against the hips. So strong is this flexure, as shown in plate XVI, that it seems probable that it could have been produced only by specially binding the limbs in this position. In the burial shown in fig. 1 of this plate the legs are flexed back so as to form

almost a straight line with the trunk, while in the one shown in figs. 2 and 3 of this same plate the legs have the same sharp flexure but are placed at about right angles to the body.

Burials in the effigy mounds show a flexure which could have been accomplished without binding, since there is in each instance a considerable angle between the lower and upper portions of the leg. Several variations in the position of the legs in relation to the trunk were found, but the main one was at about right angles to the body. See plate V.

BURIALS OF PARTLY CREMATED REMAINS

The separate burial of partly cremated bones occurs in the same mounds where the burials in the flesh are found. As above mentioned, they are attended by the same careful stratification of sacrificial earths and fires as are the regular burials in the flesh.

This whole custom of partial cremation forms a curious transition between total cremation and burial, and may possibly represent the grafting of the one custom upon the other. It might also represent an ancient custom which was decadent but which was ceremonially reproduced as a purification rite.

BUNDLE RE-BURIALS

The bundle re-burial of forty-five skeletons unearthed in the large conical mound, shown in plate XIII, was perhaps the most impressive find in these excavations. Four views of this mass of re-burials are shown in plates XIV and XV. Evidently, in this instance, the original burials had been in trees or on scaffolds, and, as was still customary among certain tribes within historic times, when the flesh had decomposed and only the bones remained they were collected and buried in some sacred ground. An interesting feature of this large cache or ossuary is that these bones were brought together and made into bundles, each containing the bones of from two to four individuals. The bones were not kept in the natural order but were simply bundled together, carefully wrapped, and the bundles placed in regular order in a large rectangular excavation. The excavation itself extended about three feet below the surrounding land level and was prepared with great care, the bottom being covered with a fairly thick stratum of bright yellow sacrificial sand.

The bundles were then placed end to end in a large quadrangle and covered with other sacrificial earth and with the regulation ceremonial fire strata, showing that these re-burials were prepared with as much care and ceremony as were burials in the flesh.

From the lower part of this cache were taken certain fragmentary remains showing the partial cremation of some of these bones before deposition here. Whether this partial cremation was intentional or accidental it is, of course, impossible to say. It is probable that forest or prairie fires might have partially destroyed the bones while they were yet in the trees, on the scaffolds, or after they had fallen to the ground. It seems as likely, however, that when the bones were collected from these aerial burials they were subjected to a ceremony of purification by fire in which these few bones were partially burned, either accidentally or intentionally. Such a practice may perhaps be a remnant of the custom of partial cremation just described as occurring in the ancient effigy mounds.

From the same level in this ossuary came, also, the unique specimen shown in plate XIX. This is the right lobe of the pelvis of a man with a quartzite arrowhead piercing it and firmly imbedded in it. The wound was received from the front and was undoubtedly the cause of death as shown by the condition of the bone, and as would be expected from such a piercing of the viscera.

INTRUDED AND INTRUSIVE BURIALS

Another very unusual type of burial is what we have termed the "intruded" burial which occurred in mound No. 5. The original mound here was a filled intaglio of bear form over which a much larger panther effigy was later built. The bear intaglio was filled by its builders to a point only slightly above the level of the present surrounding land surface and may represent a low form similar to other bear mounds in this same group. Later a pit was dug in it, possibly by a different people. It extended below the bottom of the original excavation and here two small children were buried in each other's arms. They were placed on top of the remains of a very carefully made ceremonial fire, and the strata above them were entirely different from those of the original excavation, showing that this burial had been placed here after the bear mound

was completed. In plate VIII is shown a cross section of the central part of the body of this mound, with its excavation, stratification, and the "intruded" burial.

The term "intruded" is here adopted for a burial which shows a deep vertical disturbance of the original strata, indicating that it was inserted after the completion of the mound in which it was placed. This is shown by the difference in the stratification above the burial from the general stratification of the mound itself. It was probably made by a people contemporary with or relatively little later than the builders of the mound thus utilized.

The "intrusive" burial, on the other hand, is usually found near the surface of a mound, shows relatively little disturbance of the strata, and is doubtless the work of quite recent tribes, as is shown by the better preservation of the bones and especially by the more recent types of artifacts. Such a burial was found in the top of the large conical mound No. 1. Plate XVI, figs. 2 and 3, show this intrusive burial with five quartzite arrowpoints placed about one knee.

In considering these several methods of disposing of the dead one can not fail to be impressed with their diversity when it is remembered that they occur in a single group of mounds. They include total cremation, partial cremation, burial in the flesh, burial of partly cremated remains, and bundle re-burials. This range is as great as might be expected in absolutely unrelated cultures from widely separated areas. From this fact alone, as well as from numerous other considerations, it appears certain that this spot was a ceremonial center which was occupied for a long period of time. Perhaps it was frequented by people of different tribes having diverse burial customs, or by a single composite tribe originating from the amalgamation of several strains each maintaining some of its own burial customs. A third possibility is that, as previously mentioned, certain of these customs may have been reserved for special classes of individuals within the tribe.

ARTIFACTS

The few implements recovered from the lower levels in the Kratz Creek group are of a much more archaic form than are those found on the surrounding surface sites.

The five quartzite arrow points found arranged around the knee of the burial in the upper part of mound No. 1, and illustrated in

plate XVI, figs. 2 and 3, are of the type usually found in the village sites of the region. This fact, together with the position of the burial and the well preserved condition of the bones, shows quite conclusively that it was an intrusive burial of relatively recent date and need, therefore, not be taken into account in a consideration of the age of these mounds.

Further, the fragments of what must have been whole pots were found associated with burials and in close proximity to sacrificial altars, as shown in plate XVIII, fig. 2, and occurred in both conical and effigy mounds. These and scattered potsherds found in the mounds were of three different classes of pottery. All were quite different from that found on the surface in the village sites about the lake.

It is a remarkable fact that absolutely no implements which could have been used in the construction of the mounds were found, except the charred remains of a wooden implement which might have been used as a shovel or which may have been a canoe paddle. In the building of such extensive earthworks it is hardly conceivable that some of the digging implements should not have been left, either by accident or design. The total absence of such tools in the mounds, with the exception of the single charred wooden implement just mentioned, makes it seem quite possible that the builders used wooden tools which were later thrown on the great ceremonial fire topping the mound upon its completion and were then consumed.

Furthermore, no stone tools of any description were found in these mounds. The construction of such intricate mounds presupposes an elaborate ceremonial procedure. Consequently it might be expected that the builders would make offerings of various kinds of stone implements, in connection with the archaic points above mentioned or with the offerings of perishable goods used as burned and unburned sacrifices to the dead. That the builders of the mounds possessed such artifacts is hardly to be questioned and the manner of their disposal is an interesting problem. There are certain explanations which suggest themselves as possibilities. Owing to the natural disinclination of native peoples to again use any object belonging to the deceased or anything used in connection with the disposal of the dead, we should expect that all such objects would receive some special disposition. Indian tribes in general have four favorite methods of disposing of such ob-

jects; burning, burial with the body itself, casting away or depositing in some lonely spot, and disposition in some body of water, such as a sacred spring, lake or river. It is quite possible, therefore, that if stone tools were used in connection with the building of these mounds they were disposed of in one of the last two manners: disposition in some secluded spot or in some sacred body of water. Possibly further researches may reveal some such hiding place in this vicinity. Similar depositories are found in certain other parts of Wisconsin, notably the sacred spring at Green lake, which likely belongs to the same cultural region as the Kratz Creek mound group.

PROBABLE AGE AND AFFILIATION

The probable age of this mound group and its affiliation with other neighboring groups, and with the surface remains in the vicinity, is difficult to determine. At present no data are available for comparison of this group with others of the region and only limited information is at hand for comparing them with the surface remains in the adjacent village sites, workshops, etc. Therefore, comparisons must be largely limited to relations within the group itself.

The mounds as a whole do not present homogeneous characteristics such as would be present had they been constructed at one time and by a single people. As mentioned in a previous section the first line of mounds, which is located along the immediate lake shore, appears to be considerably older than the second line which is at some distance from the lake. Numerous contrasts between these two archeological groups have already been pointed out and lead to the conclusion that they were constructed by different peoples and that considerable time elapsed between the building of the first and the second.

The differing methods of construction of the mounds in these two sections throw some light on their relative antiquity. Attention has already been called to the fact that there are apparently two distinct methods of constructing effigy mounds. In the one the effigy is first formed by an excavation or intaglio of the same shape and about the same size as the finished cameo mound. It is then filled in and the cameo built with great attention to stratification. In the other method several small conicals are so disposed as

to outline the form of the effigy and the intervening spaces are later filled in. One unusual example of the use of conicals in this manner is seen in the panther mound superposed upon an original bear form. Here the conical seems to have been employed to delimit the superposed panther, but the whole panther is largely devoid of special stratification.

Since the conical is presumably almost the only form of mound built by fairly recent tribes it may be assumed that this method is later than the intaglio method. In fact, it seems probable that the outlining of the effigy by means of conicals may represent an attempt by a later people to imitate the more elaborate structures of the earlier builders, who employed the intaglio method. To a people previously acquainted only with the construction of the conical nothing would be more natural than to so utilize this simple form.

Another proof of difference in age between these two divisions is shown in the fact that certain of the effigies, in the older division of the group, particularly those of the so-called bear form, are low, simple in stratification, and do not contain original burials, characteristics of the later effigies. The most striking evidence of this age relation is shown in mound No. 5, where an original low bear mound was later covered by a much larger panther mound. The difference in chronology is clearly shown in the stratification as well as in the superposition of these two. Originally there was built a bear intaglio which was then made into a low cameo by filling with several strata. After its completion a pit was dug in this bear, to a point below the bottom of the original intaglio, and a special burial placed here. This marks an entirely different stage in the mound and may indicate a considerable lapse of time. That it was done by a people of similar culture if not by the same people who built the bear effigy is shown by the fact that the stratification above this burial is quite similar to that of the mound itself. At this same time or possibly very much later there was built over this bear a much larger and more simply constructed mound of panther form.

The low bear mounds mentioned above were found in the vicinity of the large crematory altar mounds, which fact may explain the absence of original burials in such effigies. These form part of the extended, and presumably older, series along the immediate lake shore, to which the detached bear mound covered by the later panther may also belong. They all show very simple stratification,

a predominance of cremation, an almost total absence of burial, and the complete absence of pottery and implements. With these features is associated to a very marked degree the overlaying fire as a final surface stratum covering, in most cases, the entire mound.

The mounds in the second and presumably later line, farther back from the lake shore, bore directly, in most instances, on the big conical burial mound No. 1. They were characterized by burials in the flesh, by more elaborate stratification and by the absence of the large crematory altar mounds. Also by partial cremation, which, as before suggested, may represent a ceremonial survival of the older custom of complete cremation found in the section nearer the lake shore. A few scattered flaked points and some pottery were found in these mounds in connection with burials and altars.

The condition of the skeletal remains in this second series of mounds showed considerable age, but the few fragmentary remains found in the mounds near the lake shore were very much more decomposed, which points to the greater age of this section of the group. The aged condition of these remains becomes even more significant when we take into account the fact that nearly all the soils here are essentially sandy and that the whole site is well elevated and drained.

When all these outstanding features are considered it appears highly probable that the Kratz Creek group was constructed at a time antedating, by some centuries at least, the discovery of America and the advent of the whites. Further, their construction extended over a sufficient period of time to permit at least two successive periods of building, showing rather marked differences and perhaps representing different cultures. The apparently older type represents possibly the original culture of the Fox river valley while the later type may be due to the subsequent occupation of the valley by another people, possibly of a related stock. This second culture, however, differed from the latest prehistoric culture of the region as is shown by the differences between the implements and pottery of the later mounds in this group and those of the village sites of this region. Particularly is this shown by the absence of copper in any form in the mounds, whereas it is quite extensively found in the surface remains of this vicinity.

Only further research in this field can determine definitely the possible extent and limits of these three cultures. In making these studies, however, it should be borne in mind that from the very

nature of the country and its remains there is as great a likelihood of juxtaposition of different cultural remains as there is of superposition of these remains. This is due to peoples of different periods occupying the same favorable localities but not the identical spots chosen by their predecessors. This juxtaposition of cultures is more difficult to recognize than is superposition but it is certain that a considerable chronological range must exist in a country where such widely different objects are found in the mounds as archaic flaked points on the one hand and silver trade crosses and other historical objects on the other.

When sufficient information is available it may be possible to establish certain more or less continuous lines of diffusion from culture centers in the Great Lakes and Mississippi valley regions. This may show not only the sources of these three mound and surface cultures but also their relation to the larger problem of mound distribution and chronology in America.

In addition to this larger problem, certain subordinate features present themselves for solution. These are:

1. Are effigy mounds elsewhere, especially those of the panther form, built first as intaglios, and then filled in stratum upon stratum, or is this practice confined to certain localities only? Further, are all effigy mounds elsewhere as carefully stratified as those in the Kratz Creek group?

2. Are small conical mounds used in outlining effigies? If so is this a later method than the intaglio and an attempt to imitate the more complex work of the earlier builders?

3. Are all effigy mounds built for mortuary and sacrificial purposes?

4. What were the sources of the sacrificial earths used in these mounds? Was the use of such earths restricted to the mounds of this region?

5. What were the property sacrifices, evidently largely cremated or consisting of perishable articles, evidences of which are still found in some of the mounds?

6. Were wooden implements used in the construction of such mounds, as the only evidence found in the present work tends to show? How otherwise may we account for the entire absence of stone digging implements?

7. How is the absence of stone and copper implements to be explained? Were they possibly deposited in a spring, creek, or other sacred place or did the builders of these mounds antedate the makers of advanced stone and copper implements?

8. Are there other instances of rebuilding mounds made by the people of an older culture, as the bear rebuilt into a panther in this group?

9. Are there other evidences of superposition or juxtaposition of cultures to be found in mound groups?

It is hoped that further projected investigation in this region with its hundreds of mounds, and its large numbers of camp sites, village sites, work shops, pottery making sites, and other ancient remains, showing ample evidence of the occupation of the region by several cultures over a long period of time, may throw further light on these problems.

DETAILED DESCRIPTION OF THE MOUNDS

MOUND No. 1

This large conical burial mound, plate XIII, fig. 1, was some seventy feet in diameter. A segment about 12.5 feet wide on the northern margin of the mound had been carried away by the inroads of the lake but none of the contents of the mound had been disturbed. At the time of its excavation the mound stood about four and a half feet above the surrounding level on the up hill side. Formerly it had been about two feet higher, but through some years of cultivation the top had been gradually lowered. The extreme summit of the mound showed an elevation above mean lake level of 20.48 feet. The mound stands just on the brow of the point, plate XIII, fig. 2, where the land begins to slope toward the south and southwest down to the small flat which borders the marsh on the northeast bank of Kratz creek, plate I, fig. 1. The first part of this slope is quite abrupt, so that in the seventy feet of the diameter of this mound the slope is approximately three and a half feet. Thus the summit of the mound stands about eight feet above its perimeter on the down hill side. The terrain continues to slope down to the water's edge which is reached at a point about 225 feet from the summit of the mound. The last hundred feet or so of this point are quite level and form a small

flat on which is located an old Indian camp site. Toward the east the land is quite level for several hundred feet and it is on this level upland that the major part of the Kratz Creek group is located.

The natural soil at the point where this mound is located shows on the up hill side of the mound a top stratum of black loam about 0.8 feet in thickness on the average, below which is a layer of brownish yellow sand about 2.5 feet in thickness. This rests upon a red clay hardpan. On the down hill side of the mound the same natural strata are found, but these are somewhat thinner, though they follow the general slope of the hill throughout. The top stratum is about 0.5 feet in thickness, while the dark yellow sandy layer is only about 1.5 feet in thickness or about half as thick as is the same layer on the up hill side. Thus it is only about two feet from the surface of the black loam down to the clay subsoil on the down hill side of the mound, whereas above, on the up hill side, it is 3.3 feet. This is probably due to the steepness of the slope and the natural wash of the soil.

The thicknesses and depths of these natural strata are of considerable importance in considering the construction of this mound which required careful excavation for its foundation. In fact, measurements taken near the center and toward the up hill side of the mound show that this original excavation must have had more or less the shape of a saucer, extending, in the center, down to the red clay hardpan and gradually elevating toward the rim. It had a diameter of probably thirty feet, only the central ten feet being dug down to the clay itself. The natural brownish, yellow sand stratum shows a thickness of about thirty inches at the outer edge of the excavation, gradually becoming less towards the center where it eventually disappears altogether:

Upon this clay base in the center of the saucer-shaped excavation, was placed a layer of bright yellow sand, about a foot in thickness. Over this was a layer of very fine red sand, about six inches in thickness. The distinctive color of this stratum made it possible to trace its extent somewhat more easily than that of the yellow sand. It was found to cover an area about 17 feet east and west by 12 feet north and south. This stratum was in turn surmounted by a second layer of yellow sand about a foot in thickness. All these three layers were special sacrificial earths which had evidently been brought from some considerable distance and purposely placed

here as a foundation upon which to deposit the cache of bundle re-burials. Thus, beginning at the bottom with an excavation extending a little over three feet below the surface of the land on the up hill side of the mound, this base was constructed of these sacrificial earths so as to bring the level up to approximately that of the natural surface on the down hill side, or about 16.5 feet above the mean lake level. Upon this carefully prepared base as a resting place the large mass of bundle re-burials, containing forty-five skeletons was placed. These disarticulated skeletons were carefully wrapped in bundles containing, as a rule, from two to four individuals. No care was taken in packing the bones in these bundles, but those of the various individuals in a bundle were simply jumbled together. Apparently each one of these bundles was carefully wrapped in some covering, such as matting, textiles or skins. Most of them were placed lengthwise, north and south. They formed a layer whose extreme dimensions were 10.2 feet north and south, by 5 feet east and west, and whose thickness averaged about one foot. The size and position in the mound of this burial is shown in text figure 2, while the vertical section shown in plate III gives its relation to the strata of the mound.

Surrounding the bundle re-burials and with it forming a stratum extending nearly to the limits of the excavation was a grayish-black mixture of charcoal, ashes and earth. This may have been in part the result of ceremonial fires built around the burial after it was in place but much of it was probably brought in from other sources and deposited here. That no considerable fire was built about this burial is shown by the condition of the bones. In fact the only charred bones taken from this spot came from its lower part and near the center. They appear to have been burned before their deposition here.

Surmounting this stratum which contained the burial and resting almost upon it was another layer varying from six inches to a foot in thickness which was composed of almost jet black material showing much disintegrated charcoal, the remains evidently of a large ceremonial fire.

The bottom of this was somewhat mixed with sand, which must have been spread over the bundles in a layer sufficiently thick to protect them from the action of the fire.

Then came in order two layers each of yellow, sacred sand and fire remains. Each was fairly thin and the whole was sur-

mounted by a layer a foot or so thick of the natural soil of the locality. The mound was, as above noted, formerly about two feet higher and it seems probable that the portion removed was of the same common earth belonging to this last top stratum.

Thus there were surmounting this mass of re-burials three distinct fire strata, which, with the fire remains beside the burial, give the four ceremonial fire layers usually associated with burials

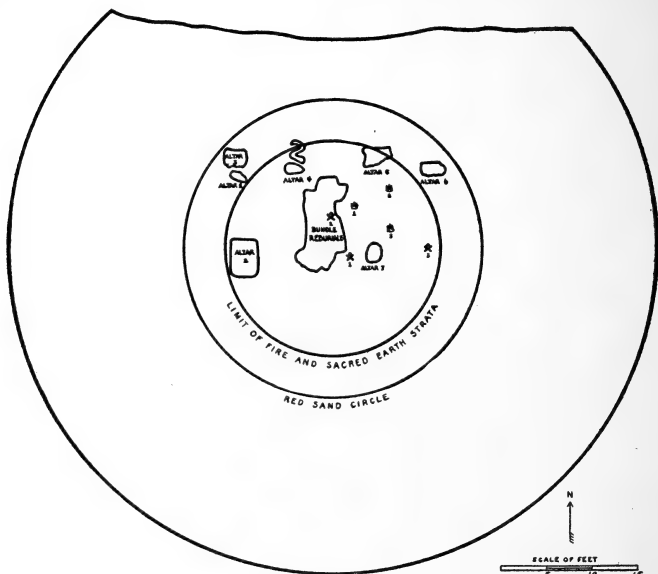

FIG. 2.—PLAN OF MOUND NO. 1

in most of the mounds of this group. In cross section these strata are slightly umbrella shaped, the topmost of them reaching a diameter of about 25 feet.

In addition to these great fire strata three small fire places were encountered. Their positions are shown in fig. 2. Fire place No. 1 was located in the first sacred earth stratum above the bundle re-burials, at an elevation of 17.9 feet above mean lake level. No.

2 and No. 3 were in the second stratum of sacred earth above the burial, and at elevations of 18.25 and 18.13 feet, respectively, above mean lake level. No. 1 was very near the eastern edge of the burial while 2 and 3 were each about five feet east of the burial and about the same distance from each other and from No. 1. There was nothing about these small fire places to show their use and their size was such as to indicate that they were probably not very important. None was more than a couple of feet in diameter by three or four inches in thickness.

In all, seven altars were found in this mound. Of these, three (Nos. 1-3) were repository altars, the remainder being associated with fire in such a way as to indicate that they were used for burned offerings. Their respective elevations above mean lake level were, viz.:

Altar No. 1,	16.11
2,	15.84
3,	16.84
4,	16.11
5,	17.95
6,	17.5
7,	16.05

Altars 1 and 3 were located, as shown in fig. 2, entirely outside the limits of the fire strata but within the red sand circle which circumscribed the entire contents of the mound. They were quite close together and nearly on the same level. Neither showed any evidences of fire. No. 1 was located in yellow sandy loam and was composed of a few stones surrounded by discolored sands which showed the decomposition of organic matter. This altar is shown in plate XI, fig. 2. About it were a few rough flakes and at a distance of 0.9 feet from it was located the single stone shown on the right in the illustration. This altar trended N 60° W and was shaped somewhat like a lancehead in outline. Its greatest dimensions were 1.8 by 0.9 feet, and it was 0.4 of a foot in thickness. Altar No. 3 was similar to No. 1 in all respects except that it was larger. It was about two by three feet in dimensions and from two to three inches in thickness, and was doubtless a repository altar like No. 1.

Altar No. 2, plate XI, fig. 1, consisted of a number of small stones with several chipped pieces. It was located in the stratum

of yellow sandy loam which surmounted the dark yellow sand layer and which abutted upon the fire blackened layer immediately surrounding the bundle re-burials. It measured about four feet north and south by three feet east and west. It was simply a layer of small, scattered stones and flakes including several archaic points, but all rested on the same level as if carefully and purposely placed on a prepared spot. Its low level and its position in relation to the bundle re-burials leaves little doubt that this altar was placed here at the time these re-burials were made and with definite relation to them.

The double altar, No. 4, was the most peculiar in form of those found in this mound. One section had an ovate outline while the other was somewhat like a figure 2 in form. Plate X, fig. 2 shows this altar as seen from the south. Text figure 3 shows it in detail



FIG. 3

and gives the relative dimensions of its parts. Its average thickness was about three inches and it was made up of fairly small rounded pebbles. A large part of the ovate section of this altar was composed of limestone pebbles and five of these were also found in the 2-shaped section. The remainder of them were of harder stones. Possibly there was some ceremonial significance attached to these various kinds of stones. The bottom of the altar was laid in yellow loam similar to that found in altars 1 and 3. Its upper part was blackened and showed evidence of having been

considerably used, probably for burnt offerings. However, no fragments of bone or other materials were present to indicate just what had been sacrificed here. The limestone pebbles, above mentioned, showed especially the evidences of fire. They were of a buff color, were very chalky and crumbled easily when exposed to the air. These are shown in the above mentioned plate.

Perhaps the most important of the altars in this mound was No. 5. This was a large crematory altar located just on the edge of the northeastern limit of the fire strata. Its form and its structure are shown in text fig. 4, and fig. 1 of plate X shows the top of this altar as it was exposed in the course of the excavations. This altar was quite unusual in that it had four successive layers of fire remains interspersed with layers of sand. The relative thicknesses of these strata are shown in the text figure above referred to. Only the top layer, which was itself about ten inches in thickness, showed any stones or other remains. Here were eleven hard stones of various kinds and about fifty fire-slacked, limestone pieces, of various sizes and of many forms, as shown in the plate above mentioned. All were imbedded in the blackest of fire remains. In fact, there were still here on the top a number of pieces of well preserved oak charcoal and also a number of pieces of half burned human bone¹⁴.

The fact that the lower three fire layers contained no stones may be explained by the assumption that as the mound was built up and its general level raised this altar, stones and all, was raised correspondingly, thus leaving only the ashes and charcoal as a layer to mark where the altar had formerly been. That this altar was a highly important one in the construction of the mound is shown not only by the presence of human bones upon it but also by the fact that it extended down to the natural dark yellow sand which formed the saucer-shaped base of the mound at this point. It reached up to a point even a little above the level of the highest over-spreading layer of fire remains, or a total thickness of 2.75 feet.

Altar No. 6 was a relatively small one, about 3 by 1.5 feet and about 0.5 feet in thickness. It was located near the top of the mound and was about two feet outside the limit of the fire strata. It consisted of a bed of ashes and charcoal underlying a consid-

¹⁴ Certain of these bone fragments were clearly recognizable, as parts of the human foot, coccyx and other bones.

erable number of stones, almost all of which were of quartzite. This was located at an elevation of approximately 17.5 feet above mean lake level.

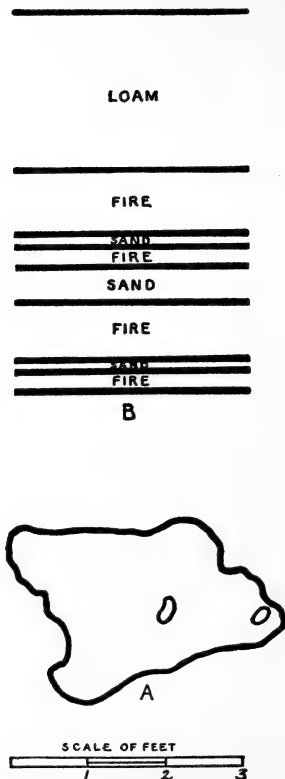

FIG. 4

Altar No. 7 was the only shell altar encountered in the mound, though several similar shell deposits were found in other mounds of this group. It might be at first assumed that this shell deposit was of no special significance but its depth in the mound, 16.5 feet

above mean lake level, its association with fire, and especially the presence of a fragmentary human jaw of a young person, still retaining two of its teeth, make it clearly of significance. It covered an irregular area some two feet in diameter and had a thickness of about 0.4 of a foot. It was located quite near the side of the bundle re-burials, and was composed of shells and shell fragments intermixed with charcoal and ashes. On top of the altar was the above mentioned fragment of human jaw which showed no evidence of fire, and also a number of charred animal bones.

One very interesting feature of the construction of this mound was a ring of bright red sand which encircled all the contents of the mound. It had a diameter of about 33 feet as represented by the outer circle at the center of fig. 2. Thus it was well outside the limits of the fire and sacred earth strata, and rested directly on the undisturbed original dark yellow sand of the saucer-shaped bottom of the mound. This ring, a foot or so wide and half as thick on the average, appears to have been placed here after the whole contents of the mound were in position, including the strata of sacred earths and the fire strata surmounting the bundle re-burials. In other words it seems likely that this ring of sacred earth represents the last act in the ceremonial procedure after the entire contents were placed and before the common earth was heaped up over them to finish the mound.

In considering this mound as a whole we are convinced that it was constructed expressly for the deposition of these bundle re-burials. The presence of three burials in the flesh is, therefore, rather an anomalous feature. One of these, No. 3, was so near the surface, the bones were so well preserved, and certain other of its features differ so greatly from those of the other two that we are forced to conclude that it is an intrusive burial of a later people. Not so, however, with the other two which are so situated as to make it certain that they were buried at the time of the construction of the mound. It is possible that these may represent individuals who died while the mound was in course of construction, which must have been a period of weeks or months rather than days. These may have been regular members of the tribe who died from natural causes, or may represent slaves or prisoners of war sacrificed in this way. This latter does not seem unlikely in view of the evidence of possible human sacrifices, found on altar No. 5.

In detail these three burials are as follows:

No. 1. This burial was located in the first stratum of yellow sand above the bundle re-burials, or at an elevation of 17.19 feet above mean lake level. It was in a very fragmentary condition but showed that the burial had been made with such a sharp flexure of the lower limbs that the heels touched the thighs. This could only have been done by binding. The body rested on its left side and faced in a general southerly direction, or away from the lake. About it were found several very rough fragments of stone, two rough stone points, and some potsherds very unlike those encountered on the surface in old village and camp sites in the vicinity.

No. 2. This skeleton was located in the top of the same stratum as No. 1 but directly over the eastern edge of the bundle re-burials. Its elevation was 17.95 feet. Like No. 1 it was very strongly flexed and lay upon its left side, though it faced W 40° N, or in general, toward the lake. This, however, was the only old skeleton found in this group of mounds which faced in this direction. It was somewhat better preserved than No. 1 but showed very great disintegration and evidence of age. In plate XVI, fig. 1, is shown this skeleton in situ. The strata above both these skeletons had never been disturbed, leaving no doubt that they were placed here when the mound was originally constructed.

No. 3. This skeleton, as above mentioned, probably represents an intrusive burial of a later date than the building of the mound. It was located almost without the eastern margin of the sacred earth area and was entirely above these strata of colored earths and fires. Its elevation was 17.4 feet at the head. The bones were comparatively well preserved, as may be seen in fig. 2 of plate XVI. This skeleton was on its left side and faced in a general south-westerly direction. In addition to its position and the condition of the bones, one other fact points strongly to its relatively recent date. It had, arranged in a circle around the left knee, which projected about six inches above the rest of the body, five quartzite arrowheads of a type quite the same as those found on later village sites in the vicinity. These were the only recent implements encountered in the excavating of this entire group, and contrasted strikingly with the few archaic points and rough chips found in

this same mound in association with other burials or about altars. In view of these several facts it seems very certain that this skeleton represents an intrusive burial of a relatively recent tribe.

MOUND No. 2

This was formerly a small conical mound which almost touched the base of mound No. 1 on its southeastern margin and which was almost directly at the end of the tail of No. 3. Through years of cultivation there is little more than a vestige of this mound left. It measured about 17 feet in diameter and had originally an elevation of not more than a foot above the surrounding surface or about 17.5 feet above mean lake level. Its vertical section showed a top stratum of black earth underlaid by dark, yellow sand about two feet thick which, in turn, rested on the clay hardpan. Comparing these layers with those of mound No. 1 it is evident that the only artificial section is the top layer of black earth. This showed no evidences of fire and there were no implements or other remains to show its special use.

MOUND No. 3

Panther mound No. 3 followed the very southwestern edge of the upland and lay largely in the woods. Its 50 foot body and 135 feet of its tail had never been disturbed. There was, however, another section of the tail about 130 feet long which, following the trend of the upland, angled off from the rest of the animal and lay in the same old cultivated field with mounds 1 and 2. Thus the total length of this mound was originally 315 feet. Mr. L. J. Dartt, who recalls quite well the appearance of this section of the tail before the land was broken, says that it was a relatively low ridge ending in a small conical tip. Its position at the edge of the slope and the long cultivation of the field had almost completely obliterated it at the time of our excavations. Its position and dimensions are therefore indicated by broken lines in text figure 5.

The undisturbed portion of this mound consisted of a head 10 feet in length, a very well formed body 40 feet long, and a tail 135 feet long. As above stated, it lay along the southwestern edge of the level upland which sloped quite abruptly down to the marsh bordering Kratz creek. The mound trended N 64° 15' W and

its highest elevation, the shoulder position, was 21.24 feet above mean lake level, or 3.04 feet above the surrounding land on the up hill side, and 5.25 feet on the down hill side.

The elevation of the body decreased rather abruptly toward the tail which itself decreased very gradually to the end where it was 18.24 feet above mean lake level, or 0.6 feet above the surrounding land on the up hill side and 1.9 feet on the down hill side.

The body of this mound was 40 feet long by 25 feet wide. It had a rounded projection 10 feet long in the head position, a considerable hump on the shoulder, and two curved legs, each about 13 feet long by approximately 10 feet wide. While all the panther effigies in this group have short bodies compared with the lengths of their tails this one was especially short and the head projection, rounded back, and special hump on the shoulder are unusual features. These are quite clearly shown in fig. 5.

This mound was built for burial purposes as is shown by the three burials in the shoulder position, and was elaborately stratified. Of all the mounds in the group this one showed the most intricate construction. The builders first made an excavation of the same form and approximately the same extent as the completed mound. The body of this intaglio was excavated to a maximum depth of 4.2 feet below the surrounding surface on the uphill side or 7.24 feet below the summit of the mound. The point of this maximum excavation was at the shoulder position, where the burials were found. A north and south or crosswise section of the mound showed that this artificially prepared floor was fairly level and was formed by the reddish brown clay hardpan. See plate IV. A lengthwise section on the other hand showed some decrease in its depth to the end of the body where it was only 3.25 feet below this same surface level. From here the depth of the excavation decreased rather rapidly to about a foot, which depth was maintained more or less uniformly throughout the length of the tail. This decrease in the depth of the intaglio of the tail is quite comparable to the decrease in the elevation of the corresponding cameo. These relations are given in the vertical longitudinal section shown in fig. 5.

Upon the floor of this excavation was built up, by a series of carefully placed strata, a resting place for the main burial which was in the center of the shoulder position of the mound, and which was accompanied by two other burials at slightly higher levels. The placement of these burials is also shown in fig. 5.

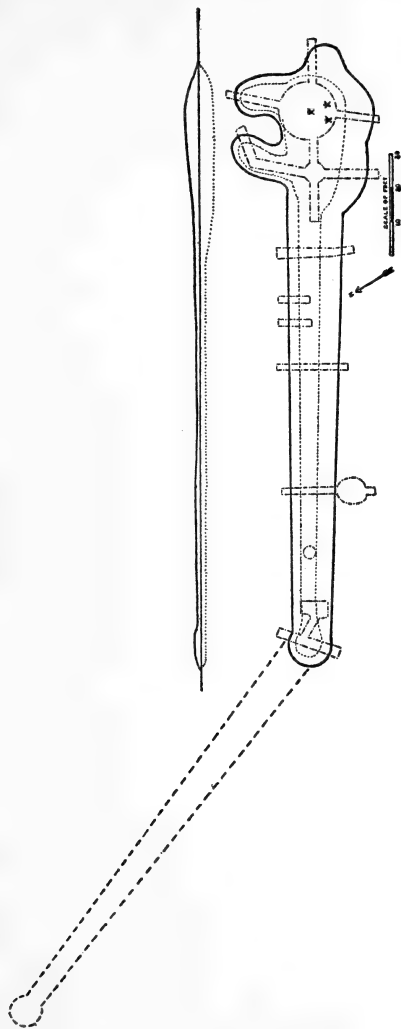

FIG. 5—PLAN OF MOUND NO. 3

These strata lacked the regularity of those in the large conical mound, No. 1, above described. Their irregularity in thickness, as well as lateral extent, is shown in plate IV.

These strata are characterized by the use of much golden sand. It appears to be placed frequently between a layer of red sand and one of red clay. This golden sand is apparently naturally quite light in color but where the iron of the red sand has filtered down it is much discolored with rusty red streaks and pockets. Only where the golden layer is quite thick is it possible to see its true original color.

The strata at the center of the mound, lying below and above the main burial were arranged in the following order:

Surface soil
 Loam
 Fire remains
 Red clay
 Remains of circle of fires
 Red clay
 Fire remains
 Golden sand
 Sandy loam
 Fire remains
 Brown earth
 Gray mottled sand
 Brown earth
 Mixed gray sandy clay
 Packed red clay
 Fire blackened sand and ashes
 Packed red sand
 Red clay in which the burial was located
 Red sand
 Golden sand
 Red sand
 Brown clay subsoil, (bottom of mound)

The second fire stratum above the burial extended about 10 feet laterally. The third fire stratum above the burial extended over a large part of the body of the mound. The top fire stratum extended as a crowning ceremonial fire over nearly the whole of the mound, including the legs and tail. It was in turn covered by a thin layer

of loam and finally by the top layer of natural decomposed vegetable matter. A very notable feature of this whole construction was the irregularity in thickness, shape, and extent of these respective layers as compared with those of mound No. 1.

A comparison of the complexity of the strata of the body of this mound with the simple stratification of the tail is shown in plate IV and text fig. 6. The latter represents a section across the tail at a point 95 feet from the head end or nearly half way down the length of the undisturbed portion of the mound.

Here the hardpan floor of the mound rises gently at its middle for about 0.5 of a foot, showing that the excavation had been carried on either side down into the clay for about six inches. A thin layer of yellow sacrificial sand covered this middle section. This was surmounted by a fairly thick layer of grayish sand, over which spread a stratum of fire remains from four to six inches thick. This



FIG. 6—CROSS SECTION OF THE TAIL OF MOUND NO. 3

stratum was a continuation of the top fire layer of the body of the mound and part of the remains of the great fire which overspread the entire mound upon its completion. Above this fire stratum at this point was a thin layer, averaging about 0.5 feet thick, of the ordinary loam.

The nature and placement above this crowning fire stratum of the layer of loam over the whole mound leaves little doubt that after the final fire was burned out the builders placed this layer as the final one on the mound. It is of ordinary loam but quite different from the black surface layer caused by the decomposition of leaves and the natural accumulation in a timbered spot.

The end of the undisturbed section of the tail of this panther consisted of a conical mound 12 feet in diameter and with an elevation of 19.08 feet above mean lake level or 1.9 feet above the surrounding surface level on the up hill side and about 0.84 feet above the top of the adjacent section of the tail. It was at this point

that the tail started to angle off toward the north, following the edge of the upland and extending toward the large conical mound, No. 1.

A transverse section of this conical, showing the peculiar form of the bottom of the mound is given in text figure 7. There was a rise in the bottom similar to that shown in the other parts of the tail and on this was a small fireplace near the center of the conical. There was also the fairly heavy fire layer near the top, which was a continuation of the overspreading fire stratum on top of the whole mound.

Only one other small and independent fireplace was found. This rested on the clay hardpan of the hind foot of the panther. Here the clay bottom dipped down about three inches, showing that it had been excavated purposely for the fireplace.

The three burials at the shoulder position of this mound were very carefully placed as shown in plate V. The central and prin-



FIG. 7.—CROSS SECTION OF PRESENT CONICAL END OF THE TAIL OF MOUND NO. 3

cipal one was that of a man of about middle age, flexed and placed on its right side facing southward. This partly excavated skeleton is shown in fig. 1 of this plate. It was 15.52 feet above lake level, about 1.8 feet above the floor of the mound and 5.9 feet below the surface of the mound at this point.

The two secondary burials were located at 17.17 and 17.23 feet, respectively, above mean lake level or 1.65 and 1.71 feet, respectively, above the main central burial. The first was that of a very young woman and was located about 5 feet southwest of the main burial. It was embedded in red clay so hard that it must have been packed artificially, a conclusion borne out by the crushed condition of the skull. The second was that of a relatively old man with the legs very strongly flexed and with strongly curved spine. It was located about five feet southeast of the main burial. These bones lay in a layer of brown-streaked, grayish earth which rested on a layer of hard packed, red clay below which was a layer of golden sand. These skeletons also faced southward. They are shown in

fig. 2 of plate V. The bones of all three of these skeletons were badly decomposed, showing that they had been buried here for a long time. This earth had been packed so hard that the bones of the head were much crushed, a condition which was found in connection with only a few other skeletons in these mounds. The vertical placement and strata surrounding these remains are shown in plate IV.

At a level 18.04 feet above mean lake level, and slightly above that of the two auxiliary burials, was the small crematory altar shown in plate IX, fig. 1. It was located 3 feet south (toward the back of the mound) from the principal burial. On this altar were various fragments of human bones, reduced almost to the condition of ash, and the whole appearance of the altar strongly suggested human sacrifice. On this same level also, and at a point about a foot north of it were the fragments of a red pottery vessel surrounded by black sandy earth. This was evidently placed on its side and may have contained an offering of food. The weight of the earth had completely crushed the vessel but from the condition of the fragments it seems certain that the pot was whole when it was originally placed here. Another pot similar in every respect to this one was found at a slightly higher level (18.62 feet) and at a point almost directly over the main central burial. The mouth of this crushed pot had been placed toward the southeast. Both these pots were probably about six inches in diameter by perhaps the same in height.

The occurrence of pockets of special sands in this mound has already been mentioned. Perhaps the most striking of these is the pocket of golden sand illustrated in plate IX, fig. 2. This peculiarly shaped pocket was located at an elevation of 18.48 feet above mean lake level. It was 1.25 feet by 1.6 feet in extreme dimensions and about one inch in thickness. Nothing was present to indicate its significance, but it seems unlikely that it was accidentally placed here. It, like various other pockets and altars, suggests at least, an animal shape.

In the red clay stratum between the third and the top fire layers, and therefore quite near the top of the mound (19.39 feet above mean lake level) was a circle of eight small fire places, each about a foot in diameter by about an inch in thickness. This circle was

some 10 feet in diameter and surrounded a central fire about 3 feet in diameter which was itself located directly over the central burial. These are indicated by three fire symbols in the cross section shown in plate IV.

MOUND No. 4

Mound No. 4 was a rather high bear (?) effigy, lying at the bottom of a small depression between the large panther effigy No. 3 and the opposite panther No. 5. It trended N 34° 15' E and occupied a focal position in four distinct lines of mounds. These lines

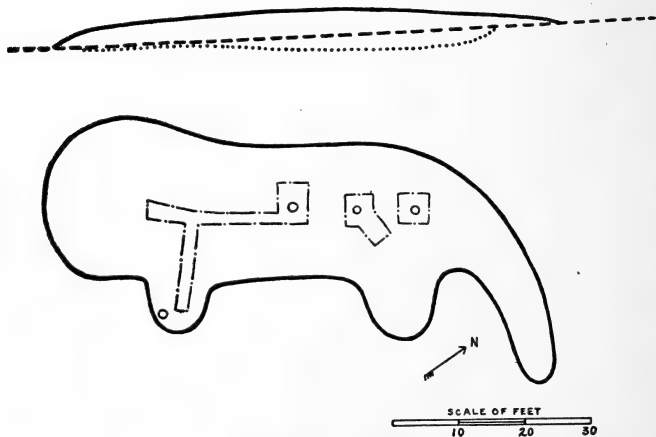

FIG. 8—PLAN OF MOUND NO. 4

were those formed by mounds 1 to 3; 5 and 6; 15 to 18, and 8, 9, 12 to 14. It therefore must have had considerable importance in relation to the general arrangement of the mound group. Its placement is shown in the large plat, fig. 1. In a mound so centrally located we would expect to find important features of stratification, or burial. However, nothing was found of special note except three separate fires placed along the centre of the northern portion of the body. The mound had an elevation above mean lake level of 20.84 feet or about 2 feet above the surface of the surrounding ground.

It was 70 feet long and 20 wide across the body. Its fore leg was 8 feet long and 10 feet wide and the hind leg 9 feet long and 12 feet wide. The tail was 20 feet long. These dimensions give an idea of the peculiar shape of the mound, with its bulging head, short rounded legs, and down-curved tail extending beyond the ends of the legs. (See fig. 8.) Like some of the other mounds of the group, this bear did not follow the regular type.

The stratification resembled that of mounds 5 and 9, the first adjacent effigies of two of the lines mentioned above. This fact may add significance to the position of the bear as the focus of these lines. The strata were taken down to the underlying quicksand, but the artificial strata do not extend that far. The bottom of the intaglio foundation of this mound was 16.78 feet above mean lake level, or 3.5 feet below the top of the mound. This would give an original excavation of 1.5 feet below the surface level. The strata at a point near the middle of the hip of the mound and slightly to the north of the last fire bed, were as follows:

Surface loam	20.73
Yellow sand	17.63
White sand	17.23
Red sandy clay	16.33
White sand	15.93
Red sandy clay	15.73
Golden sand	15.33
Red sandy clay	15.23
Golden sand	15.03
Red sandy clay	14.93

Bottom of Mound:

Mottled sandy clay	14.73
White sand	13.73
Mottled sandy clay	13.03
White sand	12.73
Quicksand	12.13

Beginning at the center of the mound and continuing through the southern portion, the top stratum of white sand was replaced by golden sand, as shown by the following stratification taken at the geometrical center of the mound.

Surface loam	20.38
Fire bed	18.78
Mottled sand	17.98
Red sandy clay	17.38
Golden sand	16.68
Red sandy clay	16.38
Golden sand	16.08
Red sandy clay	15.88
Golden sand	15.78
Red sandy clay	15.58
Golden sand	14.98
Red sandy clay	14.78

Bottom of Mound:

Mottled sandy clay	14.48
Coarse white sand	13.48
Mottled sandy clay	12.78
Coarse white sand	12.28
Gray clay	10.18

There are present in this southern section of the mound two additional strata, which, combined with the absence of fires here and the replacement of the first stratum of white with the golden sand, indicates that this mound may have been built in two sections, as was evidently the case in adjacent effigies in this group.

The difference in form and stratification between this mound and the earlier bear forms is discussed in speaking of mound 34.

MOUNDS Nos. 5 TO 7

Mound No. 5 furnished the most striking evidence of a definite chronology in this group, since it was composed of a late panther form actually superimposed on one of the early bear group. This is the only instance, to our knowledge, where such a case has been recorded, but it is possible that more such cases may come to light with a more careful study of the stratification of effigy mounds. As already stated, the first line of mounds along the lake shore, composed mostly of small, low bear effigies and conicals devoted to cremation, appear to be older than the larger effigies of the second line which are mainly of panther form and devoted to burial. In short, there appears to be in these two lines of mounds a juxtapo-

sition of cultures, and in No. 5 where they meet, we have actual superposition of the representative of one culture upon that of the other, which clinches the argument as to the relative antiquity of the two lines of mound. This proves conclusively that in mounds as well as in village sites we may have actual superposition of cultures and remains.

Mound No. 5 lay in line with the larger effigies and the big conical, No. 1, of the second line of mounds and bore E 12° 30' S. The superimposed panther form was 197 feet long. The body was short in proportion to the tail, being only 35 feet long and 20 feet wide. Where the tail joined the body it appeared to curve away from the adjoining small conical, No. 7. This latter mound contained an animal sacrifice, which may have been the reason for avoiding it. The legs of the panther body were 16 feet long. The front leg was 13 feet wide and the hind leg 10 feet wide. Both have the peculiar rounded shape characteristic of the mounds of this group. The absolute elevation of this mound above mean lake level was 21.68 feet, and the elevation above the surrounding ground was 3.48 feet.

The following measurements of the bear figure show the great difference in size between it and the superimposed panther. The length was only 37 feet and the width 19 feet. The legs were 10 feet long and 6 feet wide. The form of the body of the bear appeared to influence the shape of the later panther, which was evidently modelled after it. (See figure 9).

The peculiar story of the construction of this double mound may be easily read in the cross-section shown in plate VIII. The original bear was built up from an intaglio excavation, with alternate layers of red and golden sands. At the top was placed a stratum of light gray, mottled sand. Above this appears the loam from leaf and grass mold that naturally accumulated over it. This deposit must have required a considerable period of time.

Later another people, or possibly the descendants of the builders of the bear, dug into the mound till they reached the golden stratum next below the bottom of the intaglio of the bear, or about a foot and a half deeper than the original excavation. Here they deposited a burial in the pit thus formed. This excavation they filled with the light grey mottled sand, interspersed with layers of brown earth probably representing unburned offerings. The

golden sand taken from the bottom of the pit was placed on top of the depression left when the pit was filled. The entire bear mound was then covered over with the dark yellow sand and loam forming the superimposed panther effigy.

A study of the stratification of the panther shows that a shallow additional intaglio was made for it. This stratification was simple and quite uniform throughout. Observations taken at the trench which crossed both the hip of the original bear mound and the beginning of the tail of the panther, showed the following strata:

Surface loam	19.78
Dark yellow sand	17.58
Whitish sand	16.68
Mixed yellow and white sand	15.98
Red sand	15.28
Mixed golden and white sand	14.68

Bottom of Mound:

Red sand	13.68
--------------------	-------

At a point 40 feet farther out on the tail the layer of whitish sand disappeared. The strata here were as follows:

Surface loam	19.88
Dark yellow sand	18.48
Mixed yellow and white sand	17.63
Red sand	16.28
Mixed golden and white sand	16.08

Bottom of Mound:

Red sand	15.38
--------------------	-------

Near the end of the tail, the mixed yellow and white sand also disappeared, giving the following strata:

Surface loam	19.28
Dark yellow sand	18.18
Red sand streak	16.98
Mixed white and golden sand	16.88

Bottom of Mound:

Red sand	16.18
--------------------	-------

This stratification was similar to that of the small conical, No. 6, lying immediately adjacent, at the end of the panther's tail.

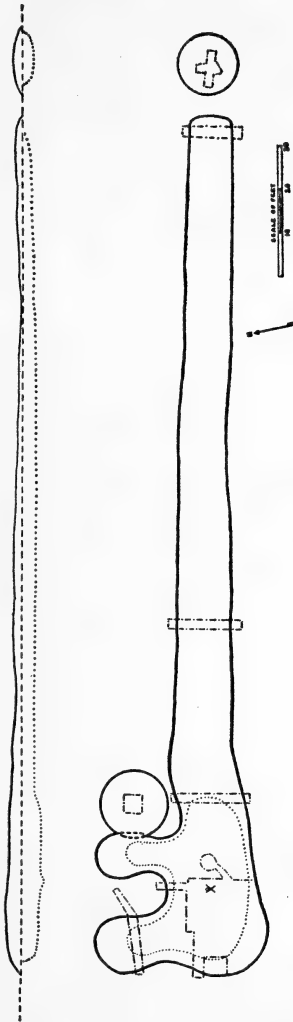

FIG. 9—PLAN OF MOUND NO. 5

The stratification of the fore leg as shown in fig. 10, consisted of:

Surface loam	19.68
Light yellow sand	19.08
Red clay	17.08
Golden sand	15.43

Bottom of Mound :

Red sand	15.08
--------------------	-------

The red clay stratum had a distinctly lens form.

The stratification of the panther effigy had all the appearance of a hasty and imperfect construction. The bear, on the other hand, was carefully built up of unmixed sands in the perfect horizontal strata shown in plate VIII, as follows:

Surface loam	18.29
Light grey mottled sand	18.04
Red sand	17.24
Golden sand	15.94
Red sand	15.04
Golden sand	14.34

Bottom of Mound :

Red sand	13.74
--------------------	-------

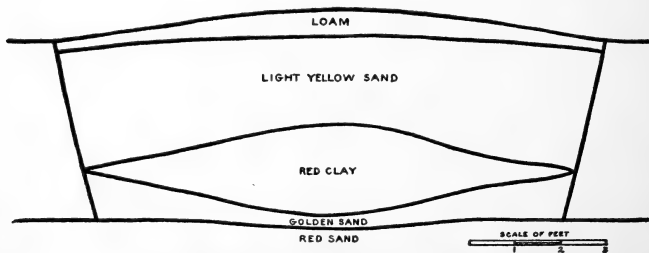

FIG. 10—CROSS SECTION OF FORE LEG OF MOUND NO. 5

The first stratum of red sand, which appeared to mark the bottom of the original excavation of the bear intaglio, was 3.3 feet beneath the top of the original bear mound or 6.9 feet beneath the top of the panther. Since the entire mound is elevated only 3.48 feet above the surrounding ground level, it is clear that the bear

mound was brought very slightly above the surface, as was the case with some of the other low bear mounds in the adjacent woods.

The stratification of the burial pit was unique, not only as a separate stratification within a mound, but for the large number of unburned offerings represented by many dark earth streaks. It contained four pairs of alternate bands of dark brown earth and light gray mottled sand above the burial; then came the burial incased in a hard-packed, brown earth; and underneath it, four more dark earth streaks interspersed in a bed of gray ash. This ash probably represented the remains of a fire built in the pit, possibly for purposes of purification, before the burial was laid down.

The burial itself was that of two infants, possibly twins, which were laid in each others arms. The skeletons were much decomposed, affording little additional data. The date of this burial was certainly later than that of the construction of the bear mound, and previous to the superimposing of the panther mound. It may have been done by the last surviving remnant of these mound builders, who took this hasty but convenient method of disposing of their dead in a mound already built.

One unusual feature of this mound is the absence of fire in it, except as above noted in the burial pit. Almost all of the other older bear mounds show several fires along the top of the mound and all the panthers were built with one or more fire strata in the mound and always with a great crowning fire layer on top of the mound. The absence of fire in connection with this mound is, therefore, very extraordinary. In the bear this may be due to its having been left incomplete and in the panther to the evident haste of construction above alluded to.

Mound No. 6 is a small conical, situated at the end of the tail of the superimposed panther mound, No. 5. It had nearly the same stratification as that of the tail of the panther. It was 14 feet in diameter, and had an absolute elevation above mean lake level of 20.78 feet, or 1.1 feet above the surface level. It probably had no special significance, except perhaps as a "marker" to delimit the outline of the panther's tail.

Mound No. 7 was a small conical situated against the hind leg of the panther effigy. It had an absolute elevation above mean lake level of 21.28 feet, or 1.8 feet above the surrounding ground. On account of its evident close relation to the panther and bear mound, it has been considered, like No. 6, along with it.

This mound contained an animal sacrifice incased in an intensely black charcoal earth, representing possibly an original covering. This fact may give color to the theory of Lapham that the animal sacrifices at Aztalan were incased in a coating of clay or other material before being burned¹⁵. This sacrifice was underlaid by the usual yellow ceremonial sand. Similar animal sacrifices were found in three other conicals, Nos. 13, 14 and 31, in this group. In Nos. 13 and 14 the position of the sacrifice was near the bottom of the mound, while in Nos. 7 and 31 it was near the top. The former were large, high conicals while the latter were small and low, which may have influenced the positions of these sacrifices. These four mounds contained no burials. This suggests that these special mounds were erected to give places for these sacrifices of animals, just as certain other conical mounds were devoted to the cremation of human remains and of sacrifices. Such special mounds were placed adjacent to those containing the burials, just as this sacrifice may have been placed here in connection with the burials in mounds Nos. 5 and 8.

The stratification of this mound, as in all those containing animal sacrifices, was more complex than that of the ordinary conical. It was as follows:

Surface loam	21.28
Fire pocket containing animal sacrifice	19.06
Dark yellow sand	18.48
Light yellow sand	18.38
Whitish sand	17.28

Bottom of Mound:

Red sandy clay	16.28
Mixed sandy clay	15.78
Red sandy clay	15.68
Mottled sandy clay	15.28
Fine yellow sand	14.28
Mottled sandy clay	13.68
Golden streaked sand	13.08
Quicksand	12.88

These strata were taken down to the quicksand 8.4 feet below the top of the mound. The artificial strata, however, did not descend

¹⁵ Op. cit. p. 44.

below the red sandy clay, 16.28 above mean lake level or 5 feet below the top of the mound, and 3.9 below surface level.

These animal sacrifices are one of the several new features found in this group of mounds. The fragile condition of the burned bones did not, however, admit of their identification.

MOUND No. 8

Mound No. 8 was a small conical situated on the western end of the "Rabbit" mound, No. 9, as though it had been superimposed on the nose of the larger figure. It would not have been treated as a separate mound had it not had a distinct conical form, and had it not contained a burial and stratification quite different from that of No. 9.

This mound was 17 feet in diameter, and had a maximum elevation of 21.04 feet above mean lake level, or 1.7 feet above the surface of the surrounding ground.

The burial, which was the main feature of the mound, was encountered 3.7 feet below the top of the mound, or 2 feet below ground level. It was in very fragmentary condition, as shown in plate XII, fig. 1. Judging from the position of the remaining portions of the skeleton, it was placed on its right side, facing the south. The legs had been flexed at right angles to the body, and the arms folded across the chest. This was the usual position of the older burials found in these mounds. Strangely enough, the head was entirely missing. This fact, together with the flexure, reduced the dimensions of the burial to a length of 3.8 feet, and a width of 1.1 feet. There was a peculiar scarification on the femur, consisting of several parallel incisions, which may have been made by those who buried the skeleton, or possibly by the teeth of some wild animal. These may be seen in the above mentioned illustration.

The bones lay on a bed of charcoal, and medium dark, fine, yellow sand. The fire bed was peculiar in that it was filled with the thin shells of lake clams and those of two periwinkle-like species, one large and the other small, which were interspersed with the charcoal. The shells lay almost entirely in the eastern portion of the fireplace, which was apparently sunk straight down in the underlying dark yellow sand to the clay subsoil, which was attained at 4.1 feet below the top of the mound, or 16.94 feet above mean lake

level. It is possible that we have in this fireplace a combination of the fire and shell altars, which were usually separate in the other mounds. The deep fire bed and the condition of the bones would indicate that they had been partially cremated. The absence of the skull may also be due to the same cause. It is a rather significant fact that the only other partially cremated burials in the flesh were found in the adjoining "Rabbit" mound, No. 9.

A large pot, probably originally filled with food, had been placed at the feet of the skeleton. It was impossible to excavate this, on account of its disintegration, but its outline may be seen in the plate above referred to. This placing of pottery with the remains was another general custom observed in the older burials in adjacent mounds.

MOUND No. 9

This mound, shown in fig. 11, represented a new form, which, following the general custom of naming mounds from animals of similar shape, we have termed for convenience the "rabbit". Several of these strange effigies were observed in other localities around the lake, so it is probable that it is a local type. It most resembles the old bear form, except for the longer body, the hump on the shoulder, and, of course, the long ear.

This mound was 108 feet long, measured from the perimeter of the small conical, No. 8, which was superimposed on its nose, to its hip. The maximum width of the body was 25 feet. The fore leg was 14 feet long and 9 feet wide, while the hind leg was 16 feet long and 10 feet wide. Each had a rounded foot, as though originally formed by a small conical. Each was 13 feet wide. The neck was nearly as wide as the body, 20 feet. The ear was 16 feet long and 8 feet wide. The elevation of the mound above mean lake level was 21.98 feet, or 2.24 feet above the surface of the surrounding ground. It trended E 2° S and belonged to the series of rather large, high effigies beginning with the panther effigy, No. 3.

A burial of partially cremated bones was found in the hip position of this mound and another of more fully cremated bones at the shoulder. The first of these is shown in plate XII, fig. 2. The positions of both were marked by fireplaces and a fire circle. Also by a series of ceremonial clays and sands packed very hard about the burial. Two special fireplaces were located on the east and west

sides, respectively, of the perimeter of each fire circle, which was about 6 feet in diameter. The burial was placed in the center of the circle and about a foot and a half below these fires or 4 feet from the top of the mound. There were several additional ceremonial strata beneath each, indicating that at these two points the

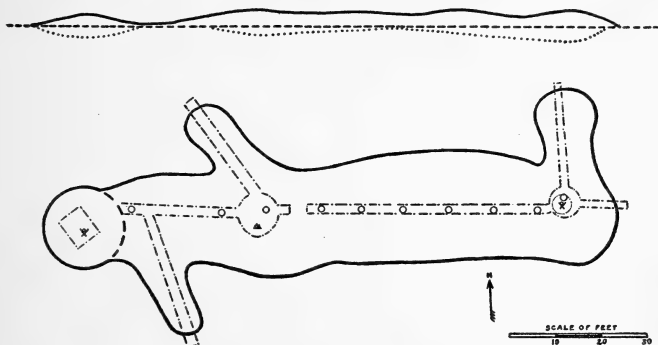

FIG. 11—PLAN OF MOUND NO. 9

original intaglio of the rabbit mound had been excavated more deeply than in its other sections. The stratification connected with the burial at the hip position was as follows:

Surface loam	21.95
Fireplace	19.73
Mottled sandy clay, covering burial.	19.31

Burial:

Red sandy clay, tamped	18.03
Golden sand, tamped	17.59
Red sandy clay, tamped	17.27
Bright yellow sand, tamped	17.25

Bottom of Mound:

Red sandy clay	16.09
Bright yellow sand	15.55
Red sandy clay	15.25
Mottled sandy clay, light.	14.97
Dark yellow sand	14.25
Clay subsoil	13.49

The strata at the shoulder position, where the almost totally cremated bones were found, were in general similar to those at the hip, but with certain variations as will be seen from the following tabulation:

Surface	22.44
Loam	22.29
Mottled sand	21.44
Cremation pocket	20.64

Burial:

Dark brown earth streak and ash layer	19.74
Mottled sand	19.34
Dark brown earth streak	18.44
Coarse light yellow sand	18.34

Bottom of Mound:

Red sandy clay	17.34
Coarse light yellow sand	17.14
Red sandy clay	17.04
Coarse light yellow sand	16.94
Red sandy clay	16.74
Golden sand	15.44
Red sandy clay	15.64
Golden sand	15.14

A further study of the stratification between these two points, with observations taken at ten foot intervals, showed that the remainder of this intaglio excavation gradually decreased in depth toward the middle of the animal body where it reached about zero. This form of excavation we have termed a half intaglio. The relations of these excavations are shown in fig. 11.

The intaglio excavation at the hip extended 6.4 feet below the top of the mound, or 3.16 feet below the surface of the surrounding ground, while that at the shoulder went down only 5.1 feet below the surface of the mound at this point.

The hip and shoulder positions of this mound showed distinctly conical-like elevations, somewhat higher than the remainder of the mound. From numerous borings and the system of trenches run through the body, legs and ear of the mound it was established that the builders, after digging these intaglios, first constructed two conicals, with complex strata and fire remains, at the deep

shoulder and hip positions. They then filled in the intervening portions of the mound with carefully placed, though quite different strata from those of these two conical sections, which contained the burials. It should be observed that these conicals were directly in line with a third conical, No. 8, which rested on the nose of this animal form and which may very likely have formed part of the animal. This further substantiates our theory that conicals were sometimes used to outline mounds of animal forms. Thus, above this half or imperfect intaglio, as it may be called, the perfect cameo was reared partly by the means of conicals and partly by a fill-in of the rest of the animal form.

MOUNDS Nos. 10 AND 11

Mounds Nos. 10 and 11 were two low, rectangular mounds lying directly north of the "rabbit" mound, No. 9. No. 10 was located near the fore foot and No. 11 near the hind foot of this effigy. Whether there was any significance in this arrangement, was not definitely determined.

Both mounds were very low, rising only about a foot above the surface of the surrounding ground. No. 11 had been considerably ploughed down, but No. 10 was in the edge of the woods, and undisturbed.

The stratification of No. 10 only was taken. This was found to be simple, with artificial strata of loam and dark yellow sand resting on a red sandy clay base. This arrangement closely resembled that of the unfinished line of mounds, (No. 21-26) nearby in the woods.

It is probable, therefore, that these two rectangular mounds were associated with the unfinished conicals, and that their proximity to the elaborate "rabbit" mound was an accident due to the later building of the rabbit.

MOUND No. 12

This mound, shown in fig. 12, was a conical-ended linear situated directly east of the "rabbit" mound, No. 9, and in line with it. Like the rabbit it bore E 2° S. It was 118 feet long, taken as a whole. The conical on the western end of the mound had a diameter of 25 feet and the conical on the eastern end a diameter of 28 feet.

The width of the connecting linear was 23 feet. The elevation above mean lake level of the connecting linear at its highest point was 22.19 feet; of the east end conical 22.59 feet; and of the west end conical 22.54 feet. The average level above the surrounding surface was 2 feet. It was the last of the series of rather high mounds beginning with the panther effigy, No. 3.

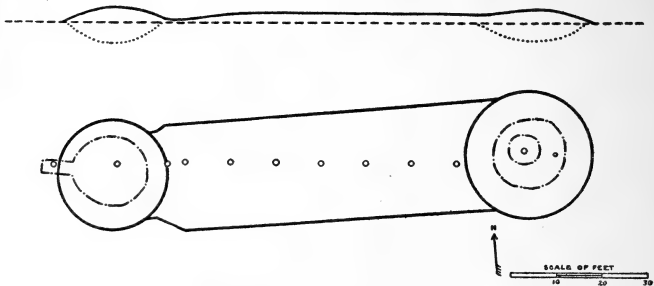

FIG. 12—PLAN OF MOUND NO. 12

The western conical, which was the smaller of the two, had been dug to a depth of about 4 feet and a burial taken out. This portion of the mound showed the most extensive stratification, and the use of many ceremonial sands, together with the usual fire strata accompanying the burial, as follows:

Surface loam	22.59
Fire stratum	19.79
Light yellow sand	19.44
Fire blackened sand	18.49
Red sand	17.09
Bright yellow sand	16.89
Yellowish white sand	16.39
Red sand	16.09
Yellowish white sand	15.69
Red sand	15.39

Bottom of Mound:

Mottled sandy clay	14.99
Dark yellow sand	14.19
Mottled gray clay	13.59

The builders had evidently dug down to this depth, 7.6 feet below the top of the conical, or 4.76 feet below the surface of the ground level and built up these ten strata.

The diameter of the fire stratum, kindled near the top of the conical, was approximately 6 feet. It was underlaid by the usual ceremonial light yellow sand, and varied from 0.3 to 1 foot in depth. On the south side of the conical a variation in stratification indicated that a subsidiary offering had been made here. A small fire was underlaid by a mixed golden and yellow sand, which was superimposed on a stratum of brownish earth-streaked sand. The latter was the usual evidence of the deposit of unburned offerings. The combination of the two showed that here was a supplementary sacrifice, of both burned and unburned offerings, to the central burial.

On the connecting linear, borings for stratification were taken every ten feet. The stratification of this section of the mound was remarkably uniform, indicating that in all probability it was filled in after the conical was built. There was a distinct break between its stratification and that of the conical, and then it ran in a uniform series of strata to the conical on the eastern end. For the first 20 feet the upper four strata, consisting of loam, light yellow sand, red sandy clay and golden sand, maintained almost identically the same levels.

The eastern conical of this composite mound, varied only slightly in stratification from the connecting linear. It contained two new strata, red sand and white clay, but did not differ from the linear so radically in number and position of strata as did the western conical. Its original excavation extended only 6.5 feet below the top of the mound or 3.66 feet below the surrounding level. This conical contained no fire strata, as did the western conical, and was not used for burial. It was evidently erected separately from the linear, but not stratified so complexly as the western conical, where a burial was placed.

The dip of the strata in the linear makes it appear probable that it was constructed by filling in from either conical toward the center. As previously mentioned, there appeared to be a general practise of building up these larger mounds sectionally, which is indicated by the sharp break in the strata at various points. On the other hand, the smaller mounds of the older group appear to have been erected as wholes, with a perfect horizontal stratification.

Thus this mound differed from the "half-intaglio" in that it had simply the two excavations of the conical ends without any intervening partial excavations, and it apparently followed the usual form of the conical-ended linear with its simply stratified "fill-in" laid directly on the natural surface of the ground.

MOUNDS Nos. 13 AND 14

These mounds, shown in fig. 13, were two large conicals directly east of the conical-ended linear mound, No. 12, and in direct line with it. Had they also been joined by a linear, they would have formed another mound of the same shape as No. 12, and trending in the same direction.

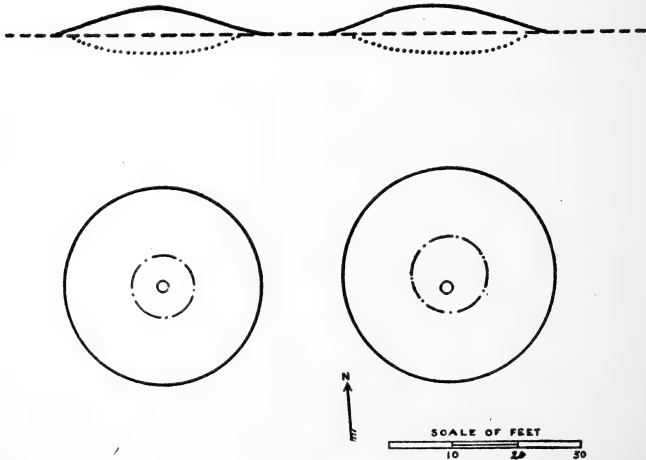

FIG. 13—PLAN OF MOUNDS NOS. 13 AND 14

No. 13 had a diameter of 30 feet and an elevation above mean lake level of 23.89, or 3.6 feet above the surrounding soil. No. 14 had a diameter of 33 feet and an elevation above mean lake level of 23.89 feet or 3.5 feet above the surrounding surface.

Both of these mounds had been dug into, and probably despoiled of their contents. It is doubtful, however, if either contained a human burial, because both appeared to be devoted to a small animal sacrifice, which was placed in a pocket of sacrificial earth. This belief is strengthened by the fact that two other conicals of this group, Nos. 7 and 31, which contained animal sacrifices, and had not been disturbed, were found to contain no burials. It is evident, then, that one of the main uses of the conicals of this group, was as depositories for animal sacrifices.

These sacrifices were usually placed at one side of the center of the mound, in a pocket of the ceremonial light yellow or golden sand, while in connection with all other sacrifices and with burials the ceremonial sand was placed in layers.

The stratification of both mounds included also prominent dark brown earth streaks, indicating additional offerings of unburned sacrifices. The general stratification of both mounds was very similar. That of No. 13 was as follows:

Surface loam	23.89
Mottled sandy clay, packed	19.89
Animal sacrifices in pocket of golden sand	19.69
Fire bed (diameter 6 feet)	19.59
Fire blackened sand	19.49
Light yellow sand	18.59
Red sandy clay	18.39
Golden sand	17.89
Red sandy clay	17.59
Golden sand	17.39

Bottom of Mound:

Red sandy clay	17.09
Golden streaked white sand	16.79
Mottled sandy clay	14.99
Mottled gray clay (subsoil).....	14.65

The strata composing mound No. 14 varied considerably in different parts of the mound. The following two tabulations of the strata show these striking differences. The first is from a point at the western edge of the excavation at the center of the mound while the second is at a point near the southern edge.

No. 1.

Surface	23.74
Loam	23.34
Mottled gray earth	22.74
Dark brown earth	22.04
Fire blackened earth	21.94
Dark brown earth	21.14
Yellowish gray mottled sand, very fine	20.99
Red sandy clay, inclosing an ash pocket containing animal sacrifice	19.54
Golden sand	18.84
Red sandy clay	18.74
Golden sand	18.44

Bottom of Mound:

No. 2.

Surface loam	23.89
Fireplace	20.89
Red sandy clay	20.49
Light yellow sand	20.29
Red sandy clay	19.29
Yellow sand	18.29

Bottom of Mound:

Red sandy clay	17.19
Dark yellow sand	16.79
Light yellow sand	16.19
Gray clay	14.79

In No. 13 our excavation went down to a depth of 9.24 feet below the top of the mound or to a point 14.65 feet above mean lake level. In No. 14 the excavation extended to the same gray clay stratum, at 14.79 feet above mean lake level or 9.1 feet below the surface of this mound. A red sandy clay layer appeared to mark the bottom of both these mounds. In No. 13 this was located at 17.09 feet above mean lake level or 6.7 feet below the surface of the mound and 2.86 feet below the surface of the surrounding land. In No. 14 this bottom was at an elevation only 0.1 of a foot higher than in No. 13, or 17.19 feet. This gives practically the same depth of artificial strata.

In No. 13 the animal sacrifice was placed in a crescent-shaped pocket of golden sand, located at an elevation above mean lake level of 19.69 feet or 4.2 feet from the top of the mound. This pocket was 2.2 feet long, 1 foot wide, and 0.3 of a foot thick. In No. 14, the animal sacrifice was placed in a pocket of gray ash at the same depth as in No. 13, or 4.2 feet below the surface of the mound. The underlying stratification, continued as in No. 13 to a considerable depth, suggesting that these animal sacrifices were of much ceremonial importance.

The sacrifices themselves were surrounded by evidences of fire. In No. 13 this was charcoal and in No. 14 it was ashes. In No. 13 the sacrifice rested immediately upon a fire layer about six feet in diameter which was in turn underlaid by a thick stratum of fire blackened sand. In No. 14, on the other hand, the fire layer was about two feet above the sacrifice, and at a level about midway between it and the surface of the mound. On account of the fragile condition of the bones, it was impossible to determine the species of the remains. The burned condition of the bones, leaves no doubt of their deposition here by the builders of the mounds.

MOUNDS Nos. 15 TO 17

Mounds Nos. 15, 16 and 17 were three small conicals situated south of the tail of the panther effigy, No. 5. As viewed in relation to the larger group, they were a continuation of the line formed by the large panther effigy, No. 3, and the great conical burial mound on the point. Their position is seen in the plat of the group, fig. 1.

The measurements of these three mounds were as follows:

No.	Elevation above lake	Elevation above surface	Diameter
15	19.9'	0.36'	12'
16	20.48'	0.94'	14'
17	20.68'	1.14'	17'

They were without special features of interest, and of comparatively simple stratification. The stratification of mound No. 15 was not taken. Mound No. 16 contained only two artificial strata, as follows:

Surface	20.48
Loam	20.33
Dark yellow sand	19.48

Bottom of Mound:

Mixed white and yellow sand	17.78
White sand	16.98
Red sand	16.38

Mound No. 17 contained a fireplace, 5 feet in diameter, and three artificial strata, as follows:

Surface	20.68
Loam	20.38
Fireplace	19.58
Gray mottled sand	19.18
Red sand	18.38

Bottom of Mound:

Golden sand	17.48
-------------------	-------

The red sand in No. 17 thinned out about 3 feet east of the center of the mound, as though the builders had run out of this material. The golden sand appeared to mark the bottom of the artificial strata. In this fire stratum a few partly burned animal bones were encountered. Otherwise no evidence was found which would show the uses of these three mounds.

MOUND No. 18

This mound was probably originally of panther shape. The body position of the mound is now occupied by the cellar of an old house site, so that the outlines are barely discernible. They are indicated in the plat of the group, fig. 1, by dotted lines. The tail runs off through the woods, bearing E 14° 45' N.

The approximate length of the mound is 205 feet. The width of the tail is 14 feet, and the estimated maximum width of the body, 35 feet. The tail of the mound rises only 1.25 feet above the surrounding surface of the ground, or 20.18 feet above mean lake level.

When the above mentioned cellar was dug some forty years ago, it is said that a skeleton was found in the body of the mound. No further information could be obtained. The mound was not trenched, so the stratification is unknown.

MOUND No. 19

Mound No. 19 is a small linear directly south of the long tail of the panther effigy, No. 18. It bears E 28° N, and was probably originally rectangular in outline, but has been considerably worn down and rounded at the corners. It tapers slightly towards the west, so that in its present state it resembles in form a stone celt.

It is a low mound, rising only 1.8 feet above the surface level, or 20.54 feet above mean lake level. It is 60 feet long, and averages 20 feet in width.

A cross-section, made at the central stake in the mound, gave the following stratification:

Surface loam	20.54
Brown sand	20.04
Yellowish brown sand	18.79

Bottom of Mound:

Red clay hardpan	17.49
Medium yellow sand	16.89
Red clay hardpan	16.19
Light yellow sand	15.89
Red clay hardpan	15.19

Apparently the mound rested on the top stratum of red clay hardpan since it was continuous beneath the mound, giving the bottom of the mound as 17.49 feet above mean lake level, or 2.95 feet below the top of the mound and 1.15 feet below the surface level.

The stratum of yellowish brown sand thinned out at the edges of the mound. The strata below this are probably natural. All the linears found in this group, with the exception of the conical-ended linear, were very simple in stratification, consisting, like this mound, of only two or three simple strata.

No intaglio form appears to have been made for the simple linears, only the black surface soil being removed when they were built. The foundation stratum, in this mound, is only 1.15 feet below the surface level.

MOUND No. 20

This mound was a detached conical, situated in the dense woods along the Montello-Packwaukee road. It did not appear to have

any particular relation to the rest of the group. It was 34 feet in diameter, and about 2 feet above the ground level, or 17.23 feet above mean lake level.

It was discovered on a second trip to the group, and was not excavated.

MOUNDS Nos. 21 TO 26

Mounds Nos. 21 to 26, inclusive, are a series of very low mounds on the west end of the older section of the group, situated nearest the lake shore. They had been placed in a direct line, and evidently were closely associated. Consequently they are treated here as a unit.

At first they were considered to be a line of low conicals, but a resurvey, when the site had been burned over, disclosed that three of them had more elaborate forms, evidently those of half finished effigies. The whole series presented the appearance of unfinished work, being simple in stratification, and none of them containing the fire strata of the finished mounds.

The first two, Nos. 21 and 22, were low conicals about 18 feet in diameter and with elevations above mean lake level of 19.34 and 19.54 feet, respectively. They contained only two strata; loam, and mottled sandy clay, resting on a red clay hardpan which was the bottom of the mounds. As has been previously mentioned, they may have been the beginnings of mounds, which were reserved for completion at a later ceremony. But it appears most probable that here we have the initial stage in the utilization of the conical in constructing effigy mounds, of which the next three mounds form the second stage.

These three mounds, Nos. 23, 24 and 25, show indefinite effigy forms, made partly by the conicals themselves, and partly by filling in earth around them. The first of these three, No. 23, has the peculiar form of an arrowhead, evidently made by filling in earth at three points on the conical. This mound is very low, roughly 0.5 of a foot above the surrounding level, or 19.74 feet above mean lake level. The outline is just discernible when the ground is absolutely bare. The stratification is similar to that of Nos. 21 and 22.

Mound No. 24 is another of peculiar form, with a legless body and an enlarged head. It measured 58 by 20 feet, with a diameter of 30 feet for the grotesque head. Had legs been added, this would have made a form similar to a mound found in the Klutz Group

across the lake. It may be a curious type, peculiar to this vicinity. Like No. 23, it was very low, about 0.9 of a foot above the surface level, or 19.94 feet above mean lake level. The stratification again was similar to that of the mounds previously mentioned.

Mound No. 25 has the shape of an unfinished bear and is similar to the other bear mounds in this older line near the lake shore. The legs are relatively short, and the head very small. This mound is also very low, being from 0.87 to 0.55 feet above the ground level, or 19.74 feet above mean lake level on the average. The stratification was slightly different from the preceding, a stratum of dark yellow sand taking the place of the mottled sandy clay. This arrangement, however, is similar to the stratification in mound No. 26, which lies immediately to the east.

Mound No. 26, the last of the series, is a small, low conical, 15 feet in diameter and having an elevation above mean lake level of 20.14 feet. Like the others, it contains no fire layer, and has two simple strata.

From the above facts one may conclude that these mounds form a unit as far as absence of fire remains and arrangement of stratification are concerned. Also that they represent two distinct stages in the development of the effigy forms from the conical.

MOUND No. 27

This mound was a great crematory altar standing somewhat apart from the other mounds of the group and situated on the edge of the bank overlooking the lake. It was composed largely of a deep fire stratum 32 feet in diameter and 4 feet thick. It had a diameter of 36 feet, and an elevation above mean lake level of 22.94 feet, or 3.5 feet above the surrounding level on the uphill side and 5.6 feet on the downhill side. Underneath this was a layer of bright yellow sand, then four pairs of alternate strata of red sandy clay and golden sand. Our excavation was not carried down to the subsoil and the exact bottom of the mound consequently was not determined. It is certain, however, that it extended some distance below the level of the surrounding land.

The top had been dug to a depth of about 4 feet. Our excavation went down to a depth of 7.7 feet below the top of the mound, but nothing was discovered to indicate its use other than as a great crematory altar. A small shell deposit was found in the southeast portion of the mound.

MOUNDS Nos. 28 TO 30

Mounds Nos. 28, 29 and 30 were located in an old ploughed field east of the series of low unfinished mounds Nos. 21 to 26 and very nearly in line with them. They were much reduced by the long cultivation of the land, and stood only a few inches above the level of the surface of the ground. Mound No. 28 was 18 feet in diameter; while mounds 29 and 30 were each 12 feet. Owing to the field being in crop the mounds were not excavated.

MOUNDS Nos. 31 AND 32

Mounds Nos. 31 and 32, shown in fig. 14, were two small conicals directly in line with the great crematory altar mound, No. 33. No. 31 was 19 feet in diameter and 20.58 feet above mean lake level, or 1.1 feet above the surrounding level. No. 32 was 18 feet in diameter

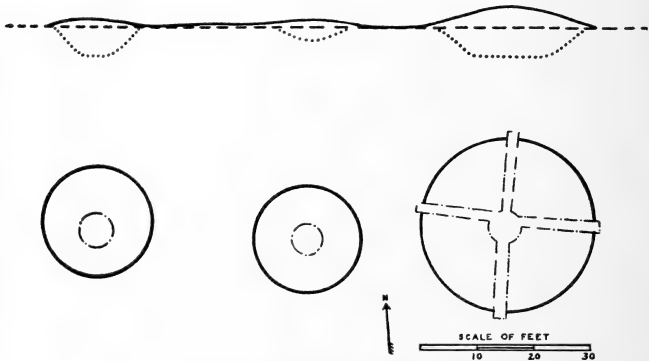

FIG. 14—PLAN OF MOUNDS NOS. 31-33

and 21.48 feet above mean lake level, or 1.3 feet above the surrounding level. Both contained fire strata, which differentiated them from the other small conicals of this line of mounds near the lake shore.

Mound No. 31 contained an animal sacrifice resting on a bed of bright golden sand. The sacrifice was imbedded in a mass of charcoal, and may have been wrapped in some sort of a covering before

being burned. It was impossible to determine the species of the animal, on account of the fragile condition of the bones, but it was evidently some small animal which may have borne a certain relation to the clan or other organization of the sacrificers. Similar sacrifices, imbedded in ceremonial sand, were found in mounds Nos. 7, 12 and 13, which were also conicals.

Mound No. 31 was highly stratified, containing 15 artificial strata. In this it resembles the newer rather than the older group of mounds, and perhaps should be placed along with Nos. 7, 12 and 13, which also contained similar sacrifices. The bright golden hue of the ceremonial sand underlying the animal sacrifice was also more akin to the golden sand of the second group than to the pale yellow sandy loam used in connection with sacrifices in the first group. These strata were as follows:

Surface loam	20.58
Animal sacrifice	19.44
Bright golden sand pocket	19.34
Dark yellow sand	19.08
Light yellow sand	17.58
Red sandy clay	17.28
Golden sand	17.09
Red sandy clay	16.28
Golden sand	16.08
Red sandy clay	15.88
Golden sand	15.68
Red sandy clay	15.38
White sand with golden streaks.	15.28
Red sandy clay	14.78
White sand with golden streaks.	14.38

Bottom of Mound:

Mottled sandy clay	14.08
Gray clay	11.98

Mound No. 32 contained a fireplace, made of small smooth stones, underlaid by a fire stratum. No other signs of any sacrifices, however, were found. It was much simpler in stratification than No. 31 and in this resembled the older type of mound. Its strata were as follows:

Surface loam	21.48
Fireplace	19.48
Fire-blackened sand	19.28
Dark yellow sand	18.88
White sand	17.58
Mottled clay	17.38
Gray clay	17.08

MOUND No. 33

This mound, like No. 27, was a great crematory altar. It was 30 feet in diameter and had an elevation above mean lake level of 23.18 feet, or 3.6 feet above the surrounding land. Its stratification was as follows:

Surface loam	23.18
Fire remains	20.98
Light yellow sand	18.88
Very fine light yellow sand	17.98
Mottled sandy clay	14.78
Golden streaked sand	14.58

Bottom of Mound:

Gray clay	14.08
---------------------	-------

These strata were in some places quite uneven. For instance, at one point in a horizontal distance of 4 feet the loam ran from 2.2 to 3.7 feet in thickness.

The fire remains measured 25 feet east and west by 17.5 feet north and south. Their depth varied, attaining a maximum of 4 feet. This mound was also a depository for perishable offerings, as was evidenced by the many streaks of decayed organic matter found in the ceremonial strata beneath the great fire. The amount of these offerings must have been considerable, since a large number of unburned sacrifices, such as clothing, would have been necessary to form these extensive lines which ran throughout the entire extent of these strata.

The depth of the ceremonial strata was 9.1 feet below the summit of the mound. They went down to the gray clay subsoil or 5.5 feet below the surrounding level showing that the erection of this mound was no slight undertaking. Fig. 14 shows a plan and

cross section of this mound. The very fine yellow sand underlying the fire stratum reached in places a thickness of 4 feet.

This mound had been dug at the center and trenched across from east to west, so that anything it contained of value must have been removed. A very interesting bird-shaped altar was, however, located in the southeast portion of the mound. This altar was imbedded in the very fine, light yellow sand used ceremonially in this older group of mounds, and had a distinct stratification of its own above it. This consisted of the very fine, yellow sand, just mentioned, a dark earth streak representing unburned offerings, a layer of mottled sand, a stratum of fire-blackened sand, a thick fire stratum, and finally the surface loam.

While not so large as the other crematory altar mound, No. 27, this mound was more carefully stratified, and contained the additional element of the deposition of unburned offerings, perhaps in connection with the cremation of bodies and other sacrifices on the great fire.

MOUND No. 34

This low-lying bear mound, shown in fig. 15, represents the typical effigy mound of the older group. It was 52 feet long, and 19 feet wide, with two short legs and almost no head. Its elevation above mean lake level was 21.83 feet, or about 1.4 feet above the surrounding level. It trended E 18° S.

It had two large fires opposite the legs, and three smaller fires at intervals along the body. These occurred at an average of 1.5 feet below the surface of the mound, or approximately at ground level. They formed a line of small fires kindled near the original top of the mound, over which a layer of loam was later spread. The strata at the shoulder position of the effigy figure were as follows:

Surface	21.83
Fireplace	20.53
Very fine yellow sand	19.82

Bottom of Mound:

Red sandy clay	17.32
Whitish sand	17.13
Red sandy clay	17.03
Mottled sandy clay	16.53

Whitish sand	15.53
Golden streaked sand	15.33
Mottled sandy clay	14.63
Whitish sand	13.43
Mottled sandy clay	12.73

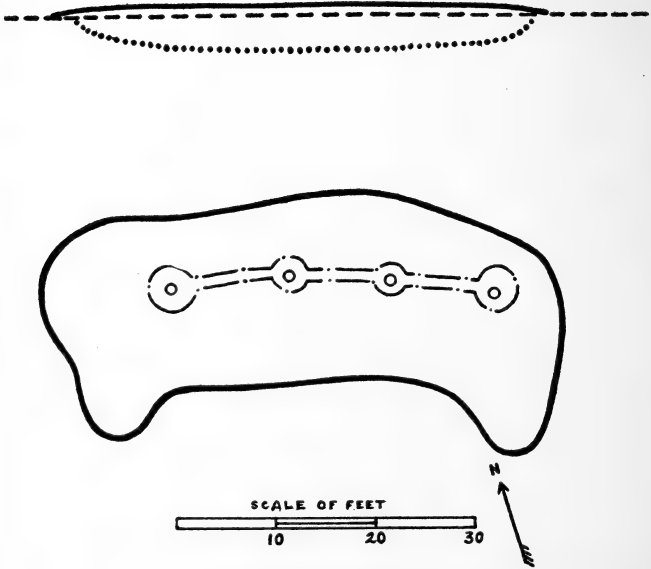

FIG. 15—PLAN OF MOUND NO. 34

This stratification shows that the excavation for this mound went down to a point 3.1 feet below the adjacent ground level, or 4.5 feet below the surface of the mound itself. Beneath the fires was a two and a half foot stratum of the very fine yellow sand, similar to that found in the adjacent great crematory mound, No. 33.

A comparison of this old bear mound with the large bear mound, No. 4, belonging to the second and evidently later line of mounds, reveals certain distinct contrasts in the construction of the two.

1. The older bear mound is smaller, much lower and more simple in stratification. It shows only a slight original excavation.

2. Different ceremonial sands were used in the two mounds. An example is the very fine yellow sand employed in the older mound which appears to correspond to the golden sand used in the newer one.

3. The strata appear to have been laid down horizontally in uniform thicknesses in the older type, whereas in the newer structures there are distinct vertical changes in the stratification in different sections.

The last point, taken in connection with other facts, would lead to the general conclusion that the smaller animal forms of the older period were constructed stratigraphically as a whole. In the later and much larger mounds, however, there appeared to be a necessity for construction in sections which led, at least in some instances, to distinct breaks in the general stratification.

MOUNDS Nos. 35 AND 36

Mounds Nos. 35 and 36, shown in fig. 16, were two more of the low-lying bear mounds, placed back to back, situated a short distance east of bear mound No. 34. Time did not permit of their excavation, but they are so similar in form and general appearance to No. 34, that this mound, as previously described, may be taken as probably typical of these also.

No. 35, which lay nearest the lake, was 78 feet long and had a body 25 feet wide. Its fore leg ran almost at right angles to the trend of the body and measured 10 feet long by 9 feet wide. The hind leg stood at an angle of nearly 45° to the body and was 17 feet long by 12 feet wide.

No. 36, which faced away from the lake, was 75 feet long and had a body averaging 18 feet wide. Its legs were indicated by short rounding projections on the south side of the mound and the head was likewise a rounded projection. These two mounds were located on a slight slope toward the east, but their average height above mean lake level was about 18 feet and that above the surrounding ground was approximately 1 foot. They trended $E 15^\circ S$.

MOUND No. 37

Mound No. 37 was the only lizard-shaped mound found in the entire group. It was the first of a series of large effigy mounds located east of the main division and separated from it by a small ravine. The mounds in this eastern sub-group exhibited certain peculiarities which differentiated them from the larger division.

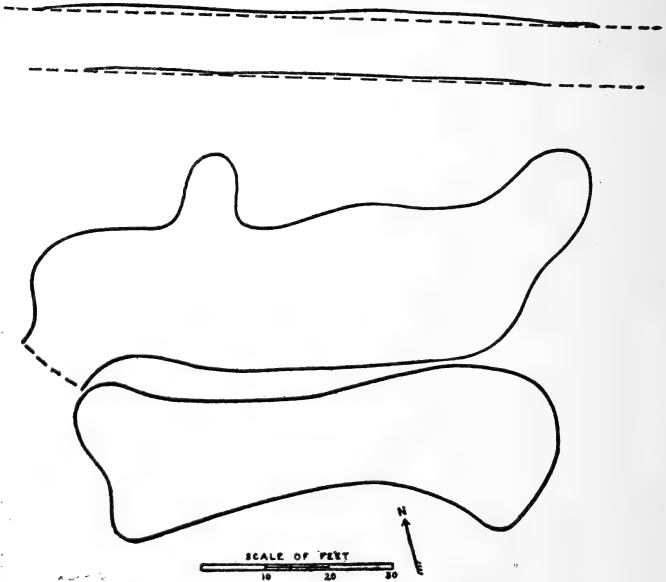

FIG. 16—PLAN OF MOUNDS NOS. 35 AND 36

These were:

1. The use of different ceremonial sands.
2. The infrequency of burials.
3. The size of the fire stratum extending in most cases over the entire limits of the mound surface.

This lizard trended E 1° N, with its tail extending part way across the ravine. It was 80 feet in length, the short tail being only

30 feet long. The width of the body was 20 feet and that of the head 15 feet. The four legs averaged 12 feet long and 12 feet wide. The average elevation of the mound above the surrounding surface of the ground was 2 feet. The elevation of its highest point, near the head, was 16.05 feet above mean lake level, while the end of its tail was only 12.25 feet above the lake. This drop is due largely to the slope of the land in this small ravine. The mound contained a top fire stratum 2 feet thick, which would indicate that the mound had been built up of ceremonial strata to the level of the surrounding ground and then this great fire, covering the form of the mound, heaped upon it.

Time did not permit a careful study of the stratification of this mound, as it was discovered in the dense underbrush after the other mounds had been excavated. Ten holes, however, were dug at various points on the mound, and it was found that the strata were uniform throughout the mound to a depth of about six feet or about 4 feet below the surface level. They were as follows: a surface fire stratum, brownish sand, dark yellow sand, light yellow sand, and red sand. It is probable that the bottom of the original excavation for this mound was the red sand. Nothing was found in this mound, other than the remains of fire, to indicate its use.

MOUND No. 38

Mound No. 38, shown in fig. 17, was in many respects the most remarkable mound of this sub-group. It was a panther mound with curious short, curved legs, and a 307 foot tail. Half way down its length this tail, abutted on the tail of the eagle effigy, No. 39. Its dominating position in this sub-group, is therefore, clear.

The length of the entire mound was 372 feet. The long tail measured 307 feet, and the body 65 feet. The body was 25 feet wide. The length of the fore leg was 23 feet, and the width 12 feet. The measurements of the hind leg were about the same, 24 by 13 feet, but the shape was different. Instead of lying at right angles to the body, it was bent at the joint and curved in toward the fore leg. The trend of this mound was E 20° S.

The mound was raised above the surrounding surface of the ground 2.66 feet, or 18.25 feet above mean lake level. A deep excavation was made in the head of the mound to determine the depth of the artificial strata, which were found to extend 6.1 feet

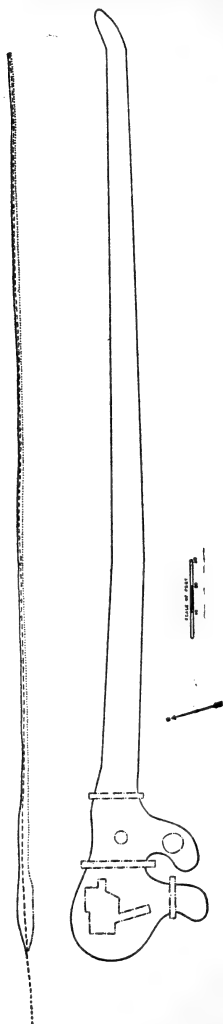

FIG. 17—PLAN OF MOUND NO. 38

below the top of the mound, and 3.44 below the surface level of the ground. Three fire strata were encountered in this excavation, each underlayed by the ceremonial light yellow sand. The strata from the top to the bottom of the excavation were as follows:

Surface	18.25
Loam	17.75
Fire remains	17.15
Fire-blackened sand	16.35
Fire remains	15.85
Mottled dark yellow sand	15.20
Clear light yellow sand	14.35
Fire remains	13.95
Light yellow sand (gray cast)	12.55

Bottom of Mound:

Red-banded light yellow sand	12.15
Blue and red clay	10.75

The presence of these three pairs of ceremonial sand and fire strata unaccompanied by a burial is difficult to explain. Likewise the depth of the excavation which was another evidence of the probable presence of a burial in most of these mounds. However, no bones, either buried in the flesh or partly cremated, were encountered. These fire strata may represent the full cremation of one or more individuals, which, of course, left no visible traces. A shell altar was found on the west side of the excavation. In other mounds, this type of altar also usually accompanied a burial. Smaller excavations were made in the hip of this panther and also in both legs, so it is not probable that a burial was missed. One must conclude, then, that, with the possible exception of total cremation, the mound builders used the ceremonial fire and sand strata here for other than burial purposes.

The great top fire, as previously mentioned, appears to be the most notable feature in these mounds, and to mark the crowning ceremony in their completion. In the case of this panther mound, the top fire stratum covers the entire body, and runs down the long tail for 160 feet, giving a fire 225 feet in length. This fire was 25 feet wide on the body and from 12 to 4 feet wide on the tail. It averaged a foot in depth. These figures give a slight conception

of the immense labor entailed in the construction of these great earthworks, of which the crowning fire stratum was only one feature.

MOUND No. 39

Mound No. 39, shown in fig. 18, was the only bird figure found in this group. It lay facing the shore of the lake with its tail abutting on the tail of the panther mound, No. 38, just described. The trend of the outspread wings was $E\ 5^{\circ}\ S$, but the body was placed at a slight angle, or $N\ 5^{\circ}\ 10'\ E$. The mound was very low, rising only 1.5 feet above the surface level, or 17.24 feet above mean lake level.

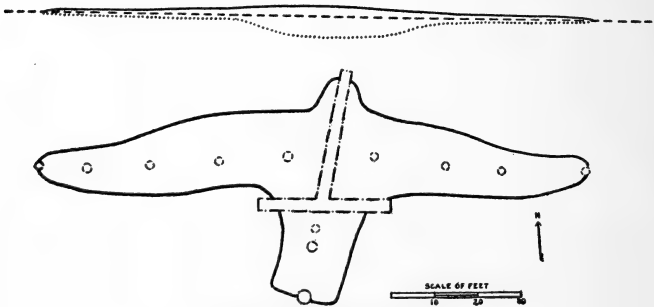

FIG. 18—PLAN OF MOUND NO. 39

The length of the body was 52 feet, while the spread of the wings was 127 feet from tip to tip. The left wing was seven feet longer than the right. The wings near the body were 18 feet wide, tapering to a width of about 9 feet near the tip. The length of the tail was 25 feet and its width was 16 feet. The width of the body near the wings was 25 feet. The head was small in proportion to the rest of the body, being only about 8 feet long and 8 feet wide.

The top fire stratum, which has been mentioned perviously as the main feature of this sub-group of mounds, covered the entire figure. On the west wing and body it was a jet-black mass of disintegrated charcoal, while on the east wing it was much lighter. On the tail and part of the east wing it was covered by a thin layer of dark yellow sand.

The stratification of this mound was comparatively simple, consisting of the surface loam, the top fire stratum, a dark yellow sand, and a light yellow sand, descending in the order mentioned. Near the center of the mound a golden sand and a red sand were found beneath the stratum of light yellow sand. Our excavation extended to a depth of 6.1 feet beneath the top of the mound, or 4.6 feet below the surface of the ground level, which probably marks the limit of the artificial strata. These strata were as follows:

Surface	17.24
Fire remains	17.14
Dark yellow sand	14.59
Mixed white and yellow sand	13.59
Golden sand	12.04
Red sand	11.14

No burials, altars, or other deposits were found in this mound. It is probable that the shape of the mound alone, together with the great crowning fire, were a sufficient offering.

MOUND No. 40

Mound No. 40, shown in fig. 19, was situated a short distance southeast of the others of this sub-group, where the land slopes considerably toward the south. It was a peculiar figure with a rounded head, two short legs, and a heavy tail, upturned at the end. Its highest point was 17.85 feet above mean lake level, and the average height above the surface of the ground was 2.66 feet. It trended W 2° S.

The body and tail were respectively 42 and 57 feet long, making a total of 99 feet for the entire mound. The width of the body was 22 feet, and that of the tail 11 feet. The length of the upturned end of the tail was also 22 feet. From these dimensions it will be seen that the area covered by the tail was nearly equal to that covered by the body of the mound. The fore leg of the figure was 9 feet long and 9 feet wide, and the hind leg 6 feet long and 7.5 feet wide.

The stratification of the mound appears similar to that of the others of this sub-group with layers of dark yellow and light yellow sand underlying the big top fire. In the head of the mound the stratification was more complex with layers of ashen gray sand and brown banded sand intervening between the fire and yellow

strata, indicating that here unburned offerings had been deposited beneath the top fire. These strata are as follows:

Surface	17.85
Fire blackened loam	17.75
Fire remains	16.10
Ashen gray sand	14.90
Brown banded earth	14.70

Bottom of Mound:

Medium dark yellow sand	14.35
Lighter yellow sand	13.55
Bluish gray clay	11.95

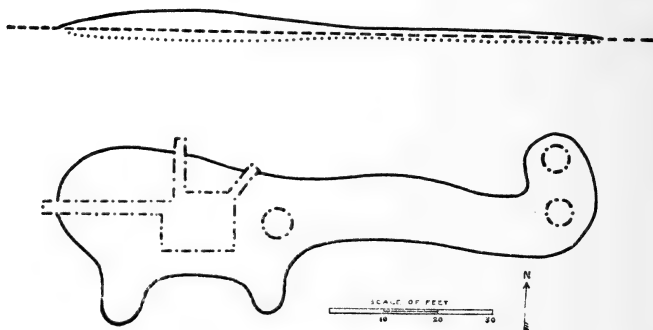

FIG. 19—PLAN OF MOUND NO. 40

Thus, the original excavation of the mound at this point was 3.5 feet below the surface of the mound, and only 0.86 of a foot below the surrounding level. It seems probable, therefore, that here also the builders of the mound only stripped off the black surface soil in making this foundation as was apparently customary in the older effigies.

A disintegrated burial was found near this same point, but in such condition that no observations could be made upon it.

At the hip position of the mound were found the charred remains of what appeared to be a wooden spade or paddle. This was the only indication of a possible digging tool found in the entire group of mounds.

MOUND No. 41

This mound was a panther effigy, which was situated a considerable distance east of the rest of the group, immediately along the high bank at the lake shore. The legs and possibly a portion of the body had been washed away by the action of the water. The tail, which extended in a southwesterly direction toward the end of the tail of the large panther, No. 38, was nearly obliterated by extensive cultivation.

The body of the mound was elevated 2.6 feet above the surrounding land, and 21.02 feet above mean lake level. The mound had a total length of 167 feet, of which the tail formed 132 feet. The shape of the body resembled that of a conical mound, being almost circular. It was 35 feet in length and 37 feet in width. It had a peculiar swollen appearance, somewhat like that of certain of the other mounds in this group.

There was no special stratification in this mound, which appeared to have been built up almost entirely of a very light yellowish-white sand, of the consistency of quicksand. In this a burial was placed, and a surface fire, about 1.5 feet thick, spread over the body of the mound.

This burial occurred at a depth of 4 feet from the top of the shoulder of the mound. The body was that of a small individual, evidently an abnormal type, judging from the large size of the head compared to the rest of the body. The skeleton lay on its right side with its head turned toward the left. The head had evidently been completely crushed when the body was interred.

The curious pathological condition of the skeleton, and the position of the mound, aloof from the rest of the group, together with the apparent lack of the careful ceremonial stratification usually afforded a burial, suggests that the builders of the mound considered this individual a monstrosity, who should be set apart from the other burials, and not accorded the usual honors paid the dead. Nevertheless, they reared this panther effigy over it, and built the usual large surface fire, perhaps out of respect to the family or clan to which he belonged.

MOUNDS Nos. 42 TO 45

This sub-group was composed of four mounds which were located on the southwest side of Kratz Creek, on the rising ground just beyond the marsh. The first two were a small and a large bear

mound placed end to end, and parallel to the lake. Somewhat to the west of these were two conicals. The bear mounds were undisturbed but very low, particularly the smaller one, and the conicals had been much reduced by cultivation. While the outlines of the bear mounds were fairly clear, it was difficult to determine the limits of the conicals since they were built on a natural rise in the ground, which sloped almost imperceptibly into the mounds.

The smaller bear effigy was only 0.5 of a foot above the surface level or 9.94 feet above mean lake level. It was 48 feet in length, and from 16 to 20 feet wide. The legs were short and stumpy, being 5 feet long and 5 feet wide. In fact both of these bears closely resembled in form the older bear mounds (Nos. 34-36) in the first line near the lake in the main sub-group.

The larger bear was 13.58 feet above mean lake level, and was slightly higher above the surrounding land than the smaller bear. It was 90 feet in length, and 28 feet wide. The front leg measured 7 feet in length and 10 feet in width; the hind leg 6 feet in length and 8 feet in width.

Conical mound No. 44 was 25 feet in diameter, and stood 1.5 feet above the surrounding level. The summit was 17.78 feet above mean lake level. The second and larger conical, No. 45, was 40 feet in diameter, and elevated 2 feet above the surrounding surface. It stood 18.5 feet above mean lake level.

MOUNDS Nos. 46 TO 51

Some distance west of the creek, between the Packwaukee-Montello road and the lake shore, was situated a line of six small conical mounds. Their position in relation to the lake and to the remaining mounds of the group is shown in the plat of the group, fig. 1. These mounds were much worn down, and had been cut into somewhat by the highway.

The measurements of these mounds were as follows:

No.	Elevation above the lake	Elevation above surrounding surface	Diameter
46	20.74'	0.68'	25'
47	22.34'	1.76'	24'
48	22.14'	1.98'	24'
49	21.14'	0.98'	25'
50	22.64'	2.48'	22'
51	21.09'	0.95'	15'

Some preliminary digging by Mr. L. J. Dartt, in mound No. 50, disclosed human bones, so that a complete excavation of the mound was made. Much the same stratification was encountered as in the simpler mounds in the main sub-group on the other side of the creek. These strata were as follows:

Surface loam	22.64
Burial	21.04
Fire remains	20.84
Fine yellow sand	19.84
Altar	18.74

Bottom of Mound:

Red clay hardpan	18.64
----------------------------	-------

The burial was that of a child, but the bones were so badly decomposed that only a few fragments of the skull and some ribs were recovered. This was in spite of the fact that the mounds were situated on a high sandy bluff and consequently well drained.

At the head of the child had been placed a large pot filled with food or some other like offering. The crushed fragments of this pot as they lay in position indicated that it was a vessel of considerable size, since they measured 8 by 10 inches.

The altar, which measured 20 by 30 inches, was built of small smooth stones, like those in the larger conicals in the first line of old mounds in the main sub-group. Like these also, it suggested that it had been built in animal form, being somewhat like the outline of the bear mounds. (See plate XVIII, fig. 1.) Some archaic flaked points had been deposited on the top of the altar.

This was the only infant's burial found in this group of mounds, except the double burial in the low bear mound (No. 5) which had been covered by a later panther effigy and was evidently also of extreme age; and that of the abnormal individual, evidently an infant or small child found in mound No. 41 at the other extreme of this group of mounds.

A CONCEPTION OF THE HISTORY OF THE KRATZ CREEK MOUNDS

The general reader often makes the criticism that works on archeology are concerned only with the dust and dry bones of antiquity and are consequently exceedingly distasteful as informational reading except to the specialist. In view of the widespread movement to educate the public in matters of anthropological interest, this condition should be remedied. Otherwise the absurd and erroneous ideas popularly gathered from a cursory examination of such works will continue to prevail except among the few who are actively engaged in it. In short, we must present the facts gathered from excavations in such a way that they will be of value not only to the specialist but to the general public.

That this may be done without sacrificing scientific truth to a popular style of presentation has just been evidenced in a work by Mr. Arthur C. Parker on "A Prehistoric Iroquoian Site",¹⁶ in which, in a separate chapter, he presents a visualization of the life of the site, based on the material found and previously scientifically described.

While this method is at best a compromise, it is perhaps better than popularizing the entire account, since the public is not interested in the remains as such, but in the life that they represent. This also should be the standpoint of the archeologist, and the fact that he has too often strayed so far from this original intention explains why his works have fallen into disfavor except among his fellows.

In the following pages an attempt is made to conceive the life of this mound group as remains show that it probably existed, an attempt which we feel is justified both from popular and scientific standpoints.

I.

Wapanosa had often heard his grandfather, White Bear, the copersmith, recount strange stories of the olden times, but none were

¹⁶ *Researches and Transactions of the New York State Archeological Association, Morgan Chapter, Rochester, N. Y., 1918.*

so wonderful as the things he had heard from the two Winnebago travelers who had lodged with White Bear last night. White Bear's stories were of war parties, of hunting or of the birds and animals who talked and acted like people. These travelers had told of a stranger who had come to their village over by the big water to the east¹⁷. He wore a great blanket which trailed after him on the ground and which was not made of quilled buckskin. It was very soft and covered with gorgeous yellow birds and flowers such as no one had ever seen before. More strange yet, his skin was white and he had long hair on his face. But strangest of all this being carried thunder and lightning in each hand. Surely he must be a great manitou.

As Wapanosa watched his grandfather deftly pound out the piece of copper into a spearpoint, he noticed how grizzled he was. No wonder he was accounted the wisest man in the village. Had he not lived longer, seen more, and traveled farther than even old Black Eagle, the medicine man?

In spite of all this wisdom White Bear had never told Wapanosa the origin of the great piles of earth on the point near the creek and along the river bank. In fact none of the old men knew about them, or if he did none would tell what he knew.

Wapanosa determined to tell his grandfather something which had been in his mind ever since he had heard of the strange being who hurled thunder and lightning. Perhaps his grandfather would laugh at this idea. Perhaps he would tell him a new story about these mounds.

"Grandfather, would it not be strange if the great white-skinned thunder-thrower were the builder of the piles of earth over on the point by the creek? And if he should come back here to live what would become of us?"

White Bear slowly laid down his stone hammer beside the heavy stone anvil. He took up his pipe, carefully filled it with kinnickinnick and deftly added a live coal. He blew a puff of smoke in each of the six directions¹⁸. Wapanosa knew that the old man was preparing to say something important. Still White Bear sat and smoked for a time in silence.

¹⁷ The landing of Jean Nicolet at Green Bay, 1634.

¹⁸ The six ceremonial points of the compass are, north, west, south, east, up, and down.

Finally he said "My grandson, you have spoken not unwisely. The strange being of whom our visitors tell us must have great power. Possibly he could build such great works as the big round mound out on the point yonder or the other one which looks like a panther with its tail almost touching the big round mound, or yet those even more strange ones far down the river bank where a flying eagle flees from the panther. Perhaps this new thunderer could do this but I do not think so. To me he seems to be a strange and new being, not one who is returning here after a long absence.

"Now, my grandson, have you seen fourteen winters and when next the maple leaf turns bright you will be no longer a boy. You must soon take your place among the young men, to hunt the bear, to do brave deeds, and to join in the ceremonies. But first you must seek the power of the manitou which shall make you strong and be your aid through life. Perhaps when you fast and find the solitude which holds your guardian spirit you may meet the great master of the river who can answer your many questions about the people of the long ago who built the earth piles out there on the point. Many of our people have sought the aid of this great water serpent but no one has yet been able to meet him. If you would succeed, my grandson, you must purify yourself in body and mind by long fasts and deep meditation in lonely places. Perhaps you may have good luck. Then you will become a great man, even greater than Eagle Tamer, the head chief. I have spoken, my grandson."

II.

Wapanosa had been gone from the village for many days, and his blackened face and yellow stripes showed White Bear that his grandson had attained his guardian.

This time it was Wapanosa who spoke with deliberation. "Grandfather, I have followed your advice. I have seen much. Many spirits appeared to me as I fasted. Many wished to help me. But still I fasted and wandered in silent places. Day and night I wandered. At last, as I had nearly fallen from thirst and hunger, I passed in the moon light near the big boiling spring¹⁹ which keeps the ice open all winter.

¹⁹ There are certain springs in this region which, though the water is cold, appear to boil owing to the presence of light sand.

"Suddenly I heard a voice from the spring calling me to enter. I obeyed and went down through the water to the home of the great water serpent. Here I remained many days in the bark lodge of this great spirit. He showed me a medicine bag of snake skin from which he took two medicines, one with power to show the dim past, the other the time of our grandfathers. The spirit then said to me: 'My nephew, I have heard your prayers and I know of all your desires since you were a small boy to learn of the earth piles on the point near your village. You shall now see these as they were built and the people who made them.' Then he gave me the first medicine to drink. This caused my spirit to travel back over the trail to the dim past, so many winters ago that they are more than the leaves of the trees in our forest.

"I stood at sunset on the point, with the serpent spirit beside me. I was looking up the big river. My spirit was lonely, for things were not as they are now, and I felt like a stranger in the land. There was no broad river, grandfather, but only a shallow stream almost hidden by the great fields of wild rice on either side. From the point I could see big woods all along the shore, covering the open spaces where our villages now stand. Had I not known the ground beneath my feet, I should not have believed, grandfather, that this was the same spot where we now make our landing.

"Many canoes were drawn up along the shore, strange dugouts with broad paddles, and the smoke of many camp fires curled up from the woods. Far up the river I could hear the wail of a death song. As I waited a large canoe drew up on the shore. In the center of the canoe lay the body of a warrior wrapped in bark. He must have been a great chief, for all the people came out of the woods to meet him, and joined in the song of the mourners. They bore him into the woods, and, prompted by the spirit, I followed them.

"They stopped at an open spot in the woods, where men were working with wooden shovels and women were carrying away the black earth in burden baskets. They had dug a shallow hole in mother earth, grandfather, but it was like none that I had ever seen before, for it was in the shape of a sleeping bear.

"Into this hole the medicine men were casting sacred earth as bright as the rays of the setting sun that glistened through the leaves of the forest. This, the spirit whispered, was great medicine,

to appease the soul of the warrior. As soon as one layer was finished, the people passed over it singing, and tramped it down smooth with their feet. Then the medicine men added another layer, until a bed of many colors had been heaped up for the great chief.

"On this bed they laid him, and piled great heaps of wood all about him. On this they placed his robes and weapons. The medicine men lighted torches, and threw them into the midst of the piles of wood, and soon a great fire was leaping through the forest. The people ran round the fire singing, but the voice of the flame was so great that I could not hear what they said. I could see them casting their digging tools and burden baskets into the fire, and the black-faced mourners throwing in bundles of wealth and slashing their faces as they passed the body of their chief. It was a strange sight, grandfather.

"Suddenly someone stumbled and fell against the flaming pyre. Thus he profaned the sacred spot. The people stopped their dancing, and raised a cry so loud that I heard it above the voice of the flames. The medicine men waved their arms, and every one fled to his canoe, and paddled away so fast that when I looked again the spot was silent and deserted.

"Then I felt myself coming up through deep waters, and awoke in the lodge of the great serpent spirit.

"After many days spent with the great serpent spirit I was deemed strong enough to take the second medicine. Again my spirit fled back through the years, but the trail was not so long as before.

"Again I stood on the point, but not so much a stranger, for the scene looked much as it does today, grandfather. The broad river was filled with canoes, and all appeared to be headed for the spot where I stood. As they drew nearer, I saw that the canoes were filled with bundles. These were the bones of their dead which they had taken down from the trees.

"Soon the point where I stood was thronged with people. They passed all around me and even through me, grandfather, but did not know that I was there. They, too, spoke a strange tongue, that I could not understand.

"They started digging under my very feet, and soon had a deep hole made, as large as your wigwam, grandfather. Into this their medicine men cast the sacred earth, but they had forgotten many of

the ways of the first people, and omitted many songs and dances. The sacred earth, too, had faded, so many moons had passed, and it no longer gleamed like the setting sun, but shone like the waning moonlight. So they used much of it, that the bones they buried might not be offended by being handled twice. Two prisoners were burned at the stake that the souls of the departed might have fitting conduct on their long journey. And around all they scattered a circle of shining red sand, like war paint, that the original color of the sacred earth might be restored.

"Then they passed the bundles of bones down into the hole, and placed them on the soft blanket of shining sands. There were more than I could count. In the place of honor they put the bundle of their war chief who had been slain by an arrow. Then the priests covered the bundles with more sacred earth, and the people tramped it down.

"Above they built a great fire to light the spirits on their long trail to the land of the dead, and when it had died down, they placed more sacred earth upon the pile, and kindled another fire. Many sleeps the ceremony lasted, and before they finished, two people died in the tribe, and were buried in the top of the mound. These they bound in skins, with their legs drawn up beneath them, and securely tied, so that they could not disturb the bones resting beneath. Then the people left, and all was silent.

III.

"Many moons passed by, and again the people came in great numbers. The river was filled with their canoes as far as the eye could see. They bore the body of their chief, wrapped in bark, and beside it, that of their medicine man, whom the spirits had taken.

"A young girl sat in the stern of the canoe, and the serpent spirit whispered to me that she and I were the only mortals who knew the secrets of the first builders of the animal piles, for he himself had instructed her.

"She led the people into the woods, near the pile where I stood. Here she stopped, and with a sacred wand she traced in the black earth the picture of a great panther. Then she bade the people

dig out the black earth, for it was not good that the bodies should lie in the ground that had been polluted. This they did, making the head deep to hold the dead, and the body less, and the tail shallow.

"Then the girl, who was wise in the ways of the old people, threw in the shining sands, red and gold, without number, and each time she threw in a layer the people tramped it down. Then they placed the body of their chief upon the shining sands, and built a great fire over him, and mourned for many days.

"Then the young girl was taken sick, and being able to see the future, she knew that she would die. So she bade the people bury her in the panther pile, along with the old medicine man, and above the great chief. The people then made a new bed of shining sands for these two over the ashes of the great fire, and marked the place where they were buried with a circle of fires.

"Then they cut down many trees in the forest, and built a great fire all over the panther pile, and transformed it into a panther of fire. So had the ancients done, and so had the girl instructed them. And into the fire they cast all their tools and the belongings of the dead, and the fire panther devoured them. Then they stole away, and the forest again was silent.

IV.

"Many winters passed, until I grew weary of watching. Then again they came, but only a pitiful remnant. They travelled fast and in silence, as though pursued by some powerful enemy. They stopped at the point, and brought ashore two small children, wrapped for burial. Their war chief whispered to their medicine man, and pointed up the river. Then I knew that he was saying that they must make haste and could not stop to dig another panther in the ground. So they dug into one of the sleeping bear piles of the old people and laid the children in it. They saved the shining earths that they dug out, but when they came to put them back they would not fit into their places. So they laid them on the top of the bear.

"Then the medicine man said that the manitou of the bear was offended, and that they should build a separate earth creature. Again the chief pointed up the river. Then he bade the people gather earth in haste, and over the bear they heaped a rough panther pile. This done they took to their canoes, and fled down the river, and again the place was silent.

"Then I felt the strong medicine working within me, boiling like the springs about our river, and again I rose up through deep waters, and found myself in the lodge of the great serpent spirit.

"Having shown me all I wished to know, he bade me return to my people, and tell them what I had seen and heard, even as I am telling you now, grandfather."

SUMMARY

This work on the Kratz Creek mound group has brought forth several interesting facts, some of which, at least, will probably hold good for mounds in other parts of the state. They are as follows:

1. The presence of at least two cultures is indicated in this group of mounds by differences of construction and contents. Both are quite distinct from the later culture shown in the villages and other sites of the immediate vicinity.
2. Effigy mounds as well as conicals were used for mortuary and sacrificial purposes.
3. In some instances, at least, these effigy mounds were first excavated as intaglios, which were later filled in and the cameo constructed. This points to the probability that the few intaglio mounds of Wisconsin are simply effigy mounds that were left unfinished. Evidences are present of the use of small conicals to delimit effigies and linears in their construction.
4. In building most effigy mounds and in some of the conicals, a very careful and systematic stratification was observed. These strata consisted of common local earths, sacrificial earths and fire layers.
5. The use of certain mounds themselves as special repository and crematory altars was found. Also the presence within certain mounds of special repository and crematory altars.
6. The presence of several types of sacrifice: (1) sacrificial earths; (2) property sacrifice; (3) animal sacrifice and (4) possibly human sacrifice. There were also striking facts

concerning the placement of these various types of sacrifices: (1) with the burial; (2) between strata; (3) on altars; (4) on the surfaces of the mounds; and (5) in special sacrificial mounds.

7. The use of sacrificial fires: (1) under, around or over a burial; (2) as fire strata (usually four ceremonial fires being built in the construction of a mound; (3) as circles of small fires; (4) as fire rings; and (5) finally as ceremonial fires completely covering the tops of the mounds.
8. The disposition of the dead: (1) by two types of cremation; (2) by two types of flexed burial in the flesh; and (3) by bundle re-burials similar to the ossuary of certain other regions. In the burials in the flesh the body was usually placed on its right side and facing south. One very peculiar form of burial here designated as "intruded" was also found.

CONCLUSION

It will thus be seen that in this one group of mounds we have a large series of important facts brought to light. These show superposition as well as juxtaposition of cultural features. Here are several methods of mound construction. The most striking single features are the elaborate stratification and the use of the intaglio foundation of the effigy which is apparently only an amplification of the custom of removing the top soil before beginning the construction of a mound. While this detailed study covers only this one group of mounds, it seems probable that various of the conditions found here obtain in other groups of the state or of this particular region at least. Similar detailed studies of other groups are much needed and will form highly interesting comparisons. It is hoped that opportunities may present themselves for these in the near future and that such comparisons may lead to the solution of many long standing problems concerning Wisconsin mounds in general.

*Milwaukee, Wisconsin,
September 4, 1918.*



EXPLANATION OF PLATE I

Figure 1. The mouth of Kratz creek, showing the marsh in which are located two large springs.

Figure 2. Buffalo lake, showing the shore opposite the Kratz Creek mound group.

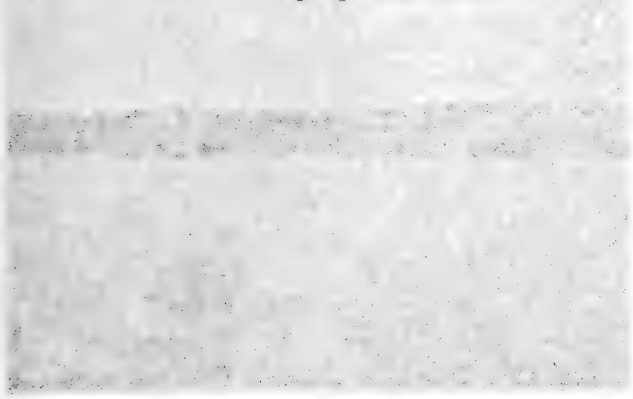

concerning the placement of these various types of sacrifices: (1) between the burial; (2) between strata; (3) on altars; (4) on the top surfaces of the mounds; and (5) in special sacrificial enclosures.

The use of sacrificial fires: (1) under, around or over a burial; (2) as fire strata (usually four ceremonial fires being built in the construction of a mound); (3) as circles of small fires; (4) as fire rings; and (5) finally as ceremonial fires completely covering the tops of the mounds.

The disposition of the dead: (1) by two types of cremation; (2) by bundle re-burials similar to the ossuary of certain other regions. In the burials in the flesh the body was usually placed on its right side and facing south. One very peculiar form of burial here designated as "intruded" was also found.

EXPLANATION OF PLATE I.

Figure 1. The mouth of Kratz creek, showing the marsh in which are located two large springs.

Figure 2. Buffalo lake, showing the shore opposite the Kratz Creek mound group.

The following is a detailed description of the cultural features. Here are several methods of mound construction. The most striking features are the elaborate stratification and the use of the custom of removing the top soil before beginning the construction of a mound. While this detailed study covers only this one group of mounds, it seems probable that various of the conditions found here obtain in other groups of the state or of this particular region at least. Similar detailed studies of other groups are much needed and will form highly interesting comparisons. It is hoped that opportunities may present themselves in the future which may lead to the solution of many long standing problems concerning Wisconsin mounds in general.

September 4, 1918.



1

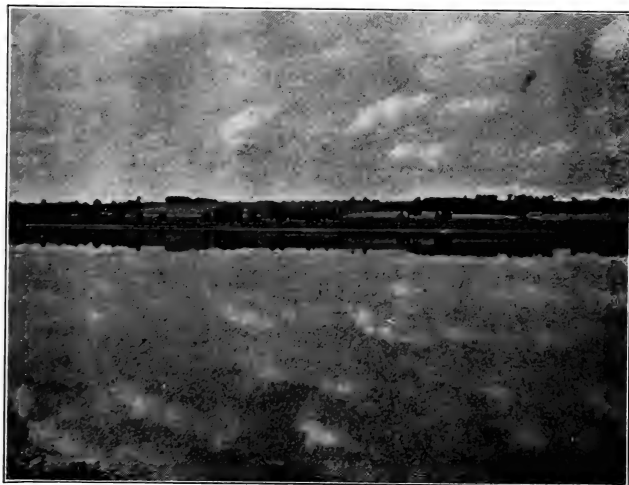

2

EXPLANATION OF PLATE II.

Panorama of Buffalo Lake taken from an elevation a short distance west of the Kratz Creek mound group.

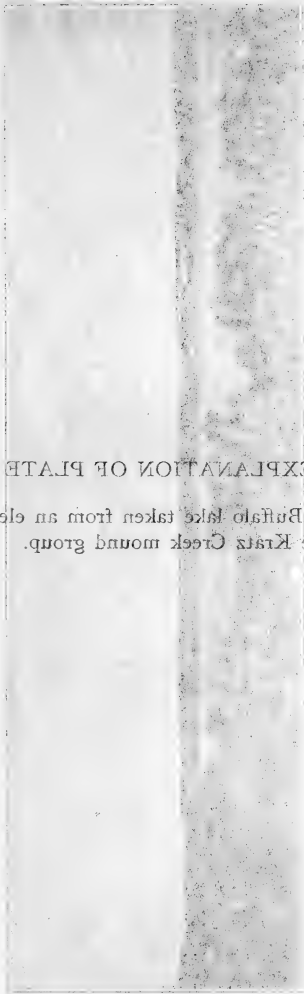

EXPLANATION OF PLATE II.

Panorama of Buffalo lake taken from an elevation a short distance west of the Kratz Creek mound group.

BULL., PUBL. MUS., MILW.

VOL. 3, PL. II.

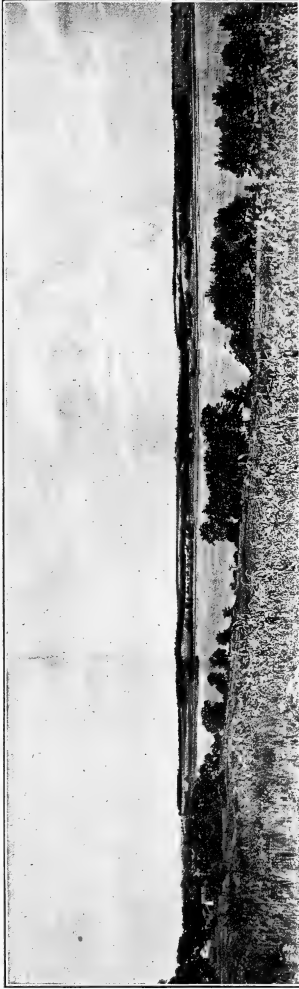

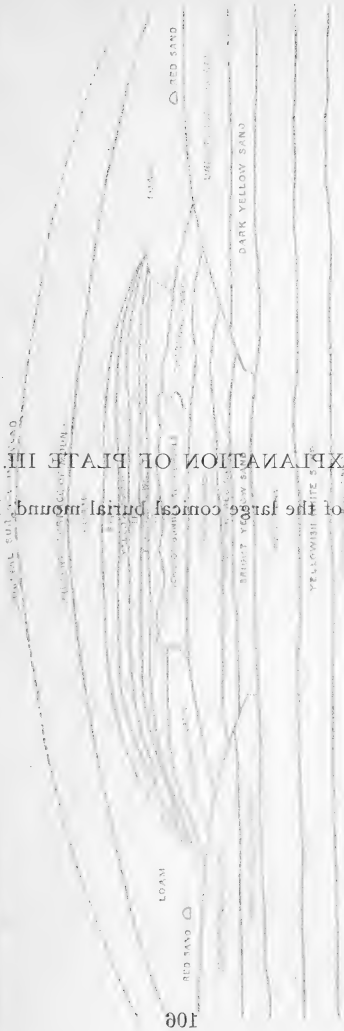

EXPLANATION OF PLATE III.

Cross section of the large conical burial mound No. 1, showing stratification.

EXPLANATION OF PLATE III.

Cross section of the large conical burial mound, No. 1, showing stratification.

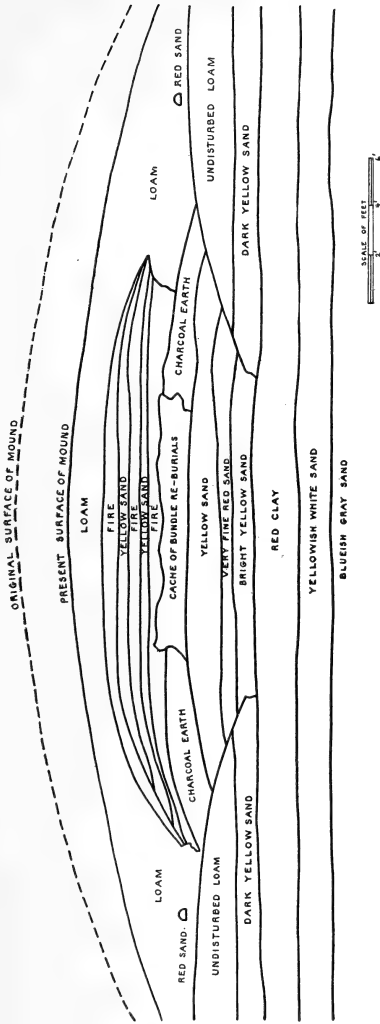

EXPLANATION OF PLATE IV.

Cross section of the painted effigy mound, No. 3, showing the stratification of the shoulder position.

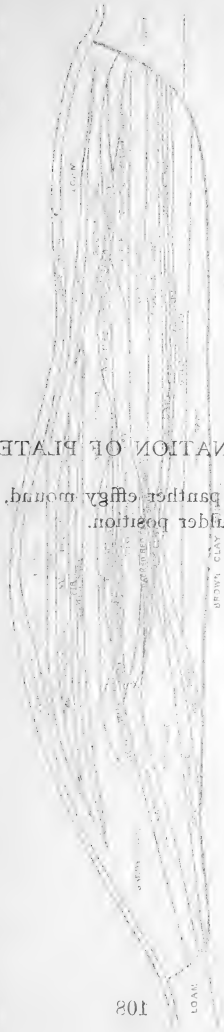

PHIL., PUBL. MUS., MILW.

EXPLANATION OF PLATE IV.

Cross section of the panther effigy mound, No. 3, showing the stratification of the shoulder position.

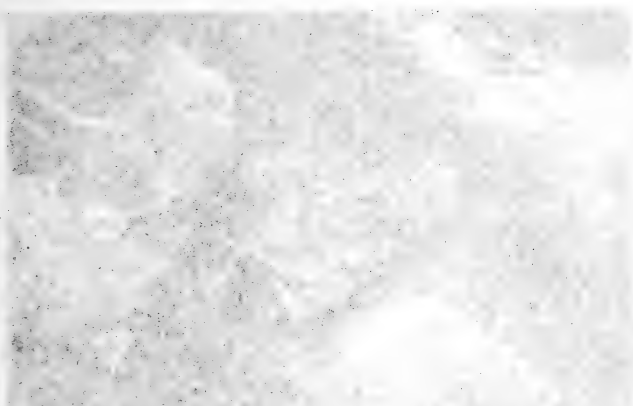

EXPLANATION OF PLATE V

Figure 1. Central or main burial in the center of the slender position in the panther effigy mound, No. 3.

Figure 2. Two secondary burials in the slender position of the panther effigy mound, No. 3.

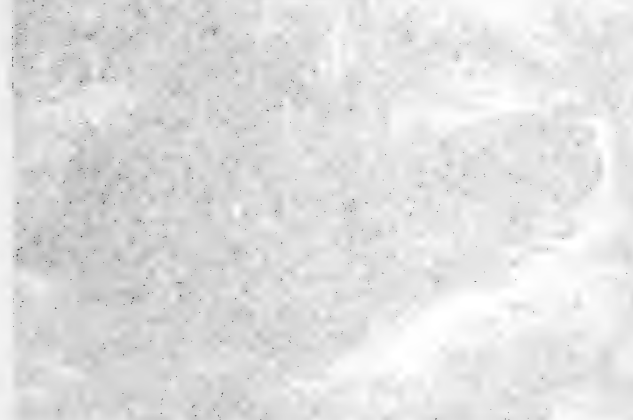

EXPLANATION OF PLATE V.

- Figure 1. Central or main burial in the center of the shoulder position in the panther effigy mound, No. 3.
- Figure 2. Two secondary burials in the shoulder position of the panther effigy mound, No. 3.



1

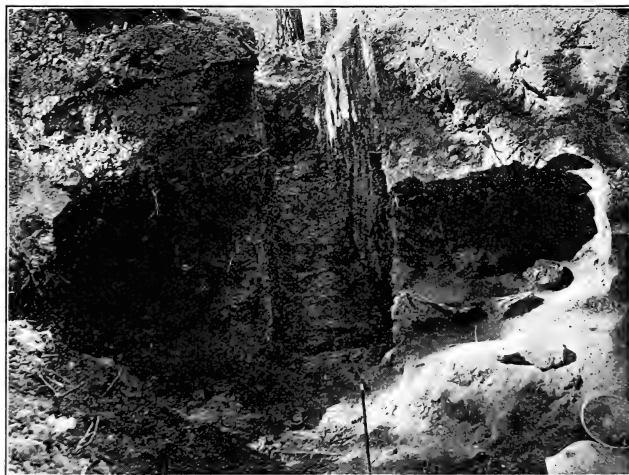

2



EXPLANATION OF PLATE VI.

The painter of the mound, No. 5, showing the body of the mound stripped of the soil.

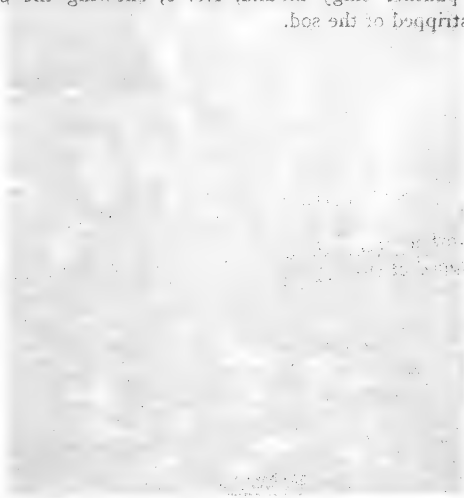

MUSEUM, MUSEUM, MUSEUM.

EXPLANATION OF PLATE VI.

The panther effigy mound, No. 5, showing the body of the mound stripped of the sod.





EXPLANATION OF PLATE VII.

Figure 1. The body of the panther effigy mound, No. 2, stripped of sod. Also mound No. 7 in the foreground.

Figure 2. The panther effigy mound, No. 3, after its excavation.

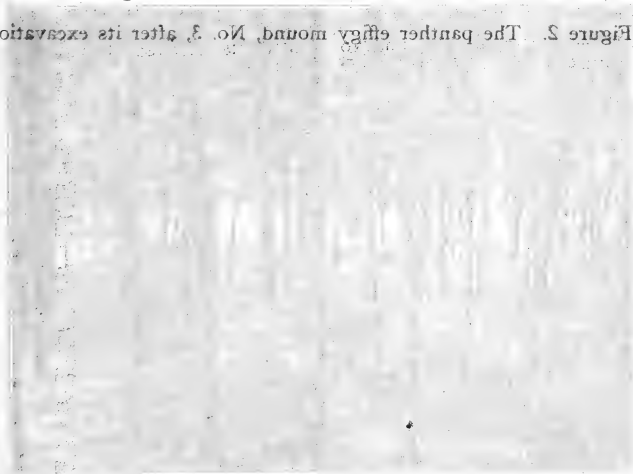

EXPLANATION OF PLATE VII.

Figure 1. The body of the panther effigy mound, No. 5, stripped of sod. Also mound No. 7 in the foreground.

Figure 2. The panther effigy mound, No. 3, after its excavation.



1



2

PUBL. MUS., MILW.

SURFACE OF PANTHER MOUND

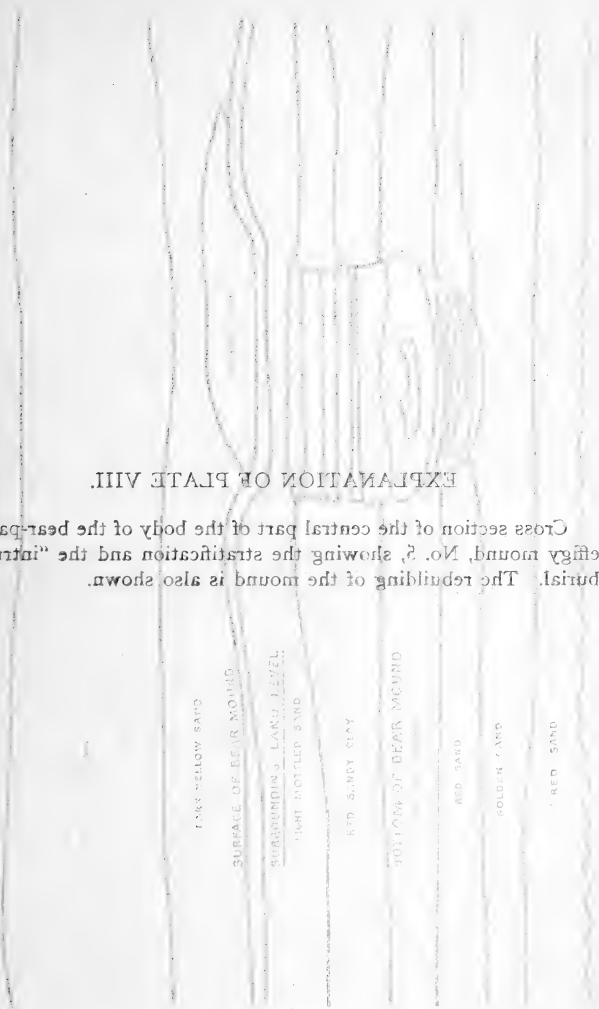

EXPLANATION OF PLATE VIII.

Cross section of the central part of the body of the bear-panther effigy mound, No. 2, showing the stratification and the "intruded" burial. The rebuilding of the mound is also shown.

THICK YELLOW SAND

SURFACE OF BEAR MOUND

SURROUNDING LAND LEVEL

LIGHT BOTTLED SAND

RED SANDY CLAY

BOTTOM OF BEAR MOUND

RED SAND

GOLDEN SAND

RED SAND

EXPLANATION OF PLATE VIII.

Cross section of the central part of the body of the bear-panther effigy mound, No. 5, showing the stratification and the "intruded" burial. The rebuilding of the mound is also shown.

SURFACE OF PANTHER MOUND



LOAM

DARK YELLOW SAND

SURFACE OF BEAR MOUND

SURROUNDING LAND LEVEL

LIGHT MOTTLED SAND

RED SANDY CLAY

BOTTOM OF BEAR MOUND

GOLDEN SAND

RED SAND

GOLDEN SAND

RED SAND

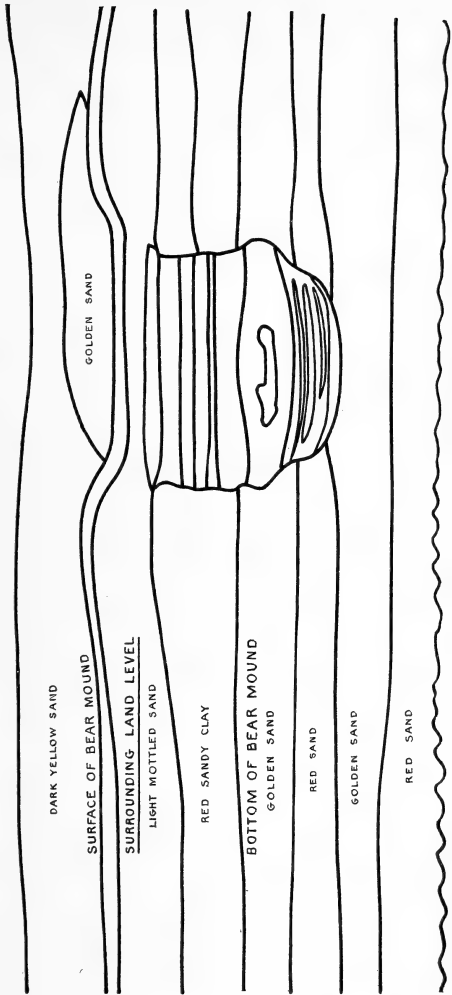



EXPLANATION OF PLATE IX.

Figure 1. An altar in the panther effigy mound, No. 3, showing partly cremated human bones.

Figure 2. A pocket of golden ceremonial sand in the panther effigy mound, No. 3.

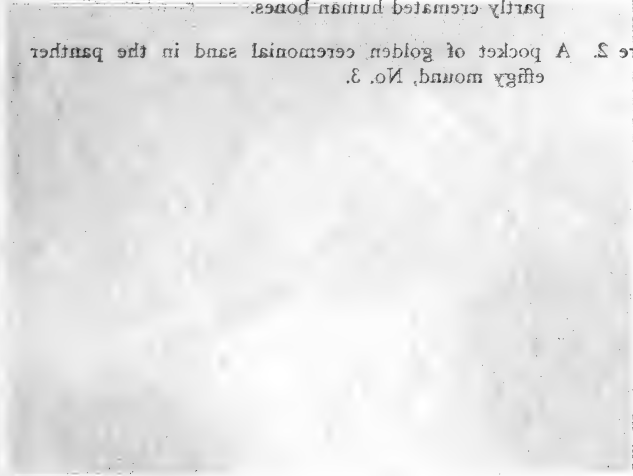

EXPLANATION OF PLATE IX.

- Figure 1. An altar in the panther effigy mound, No. 3, showing partly cremated human bones.
- Figure 2. A pocket of golden ceremonial sand in the panther effigy mound, No. 3.



1

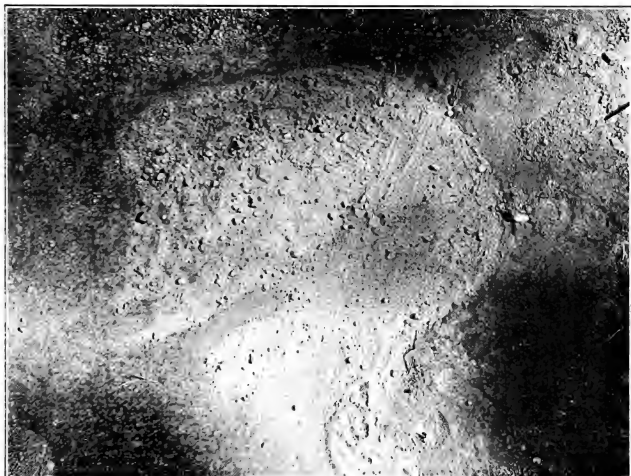

2

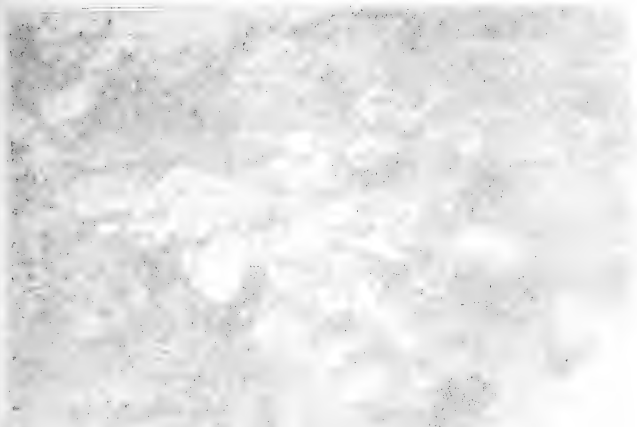

EXPLANATION OF PLATE X.

Figure 1. A large crematory altar (No. 2) in the conical burial mound, No. 1. This altar shows fragments of charred human bones.

Figure 2. A repository altar (No. 4) of peculiar form in the conical burial mound, No. 1.

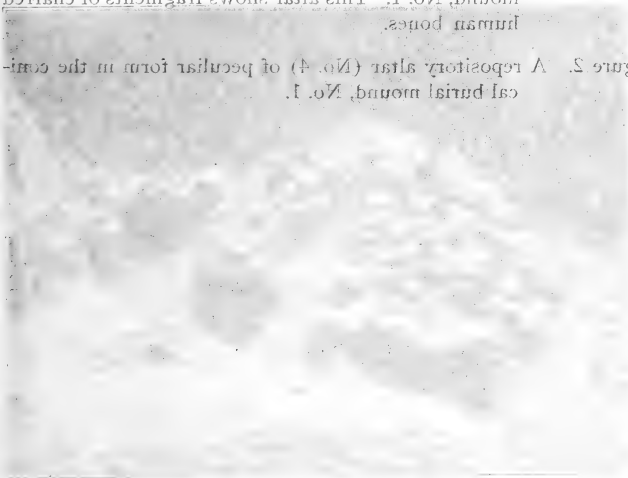

EXPLANATION OF PLATE X.

- Figure 1. A large crematory altar (No. 5) in the conical burial mound, No. 1. This altar shows fragments of charred human bones.
- Figure 2. A repository altar (No. 4) of peculiar form in the conical burial mound, No. 1.



1

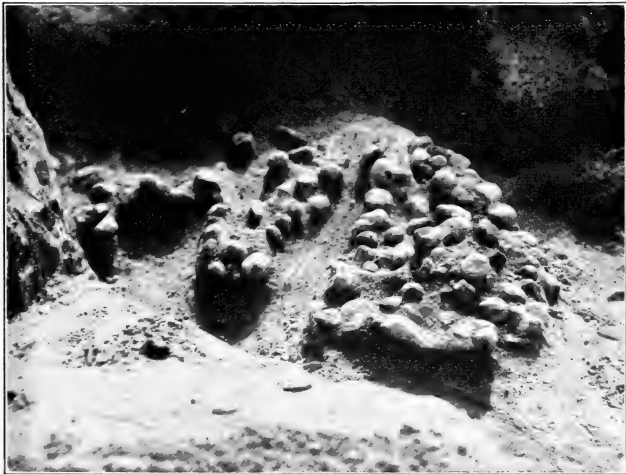

2

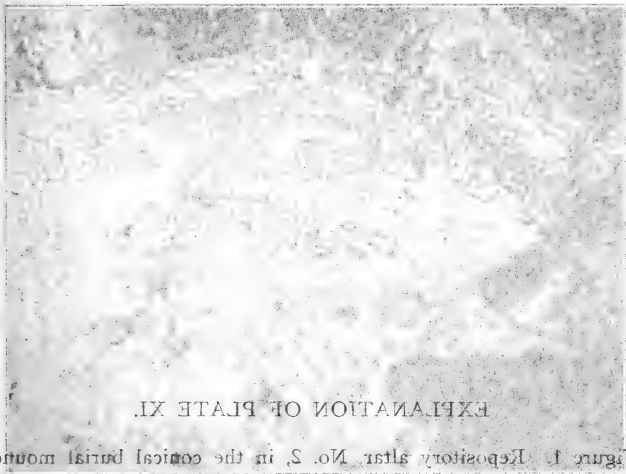

EXPLANATION OF PLATE XI.

Figure 1. Repository star No. 2, in the conical burial mound, No. 1.

Figure 2. Repository star No. 1, in the conical burial mound, No. 1.

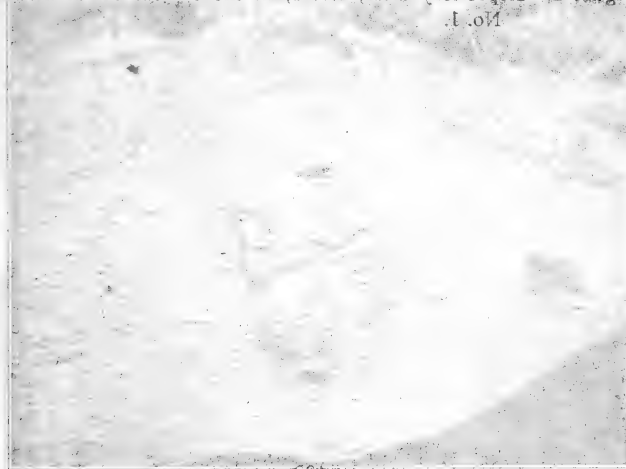

EXPLANATION OF PLATE XI.

Figure 1. Repository altar, No. 2, in the conical burial mound,
No. 1.

Figure 2. Repository altar, No. 1, in the conical burial mound,
No. 1.

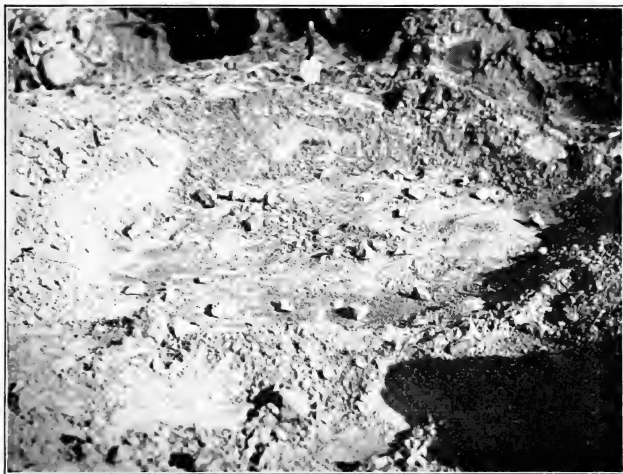

1



2



EXPLANATION OF PLATE XII.

Figure 1. A partially cremated skeleton in the small conical mound, No. 8.

Figure 2. The remains of a cremated skeleton in the rabbit effigy mound, No. 9.



EXPLANATION OF PLATE XII.

- Figure 1. A partially cremated skeleton in the small conical mound, No. 8.
- Figure 2. The remains of a cremated skeleton in the rabbit effigy mound, No. 9.



1



2

EXPLANATION OF PLATE XIII.

- Figure 1. The large conical burial mound, No. 1, partly excavated.
- Figure 2. Kiatz point as seen from the lake. Most of the Kiatz creek group of mounds are located in the woods on this point.

EXPLANATION OF PLATE XIII.

- Figure 1. The large conical burial mound, No. 1, partly excavated.
- Figure 2. Kratz point as seen from the lake. Most of the Kratz creek group of mounds are located in the woods on this point.



1



2

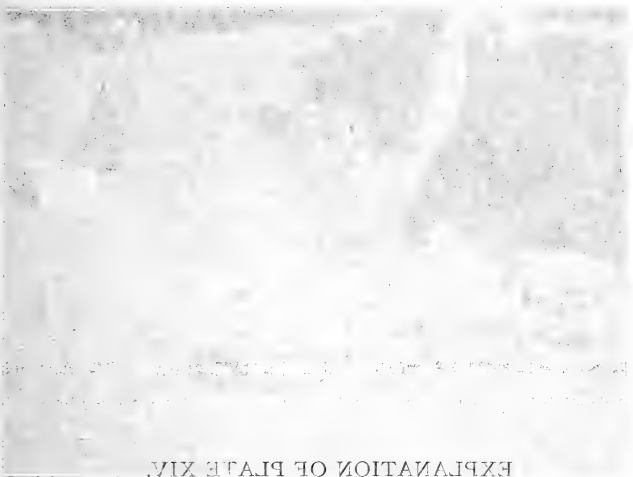

EXPLANATION OF PLATE XIV.

Two views of the large ossuary of bundle re-burials found in the center of the conical burial mound, No. 1.



EXPLANATION OF PLATE XIV.

Two views of the large ossuary of bundle re-burials found in the center of the conical burial mound, No. 1.



1

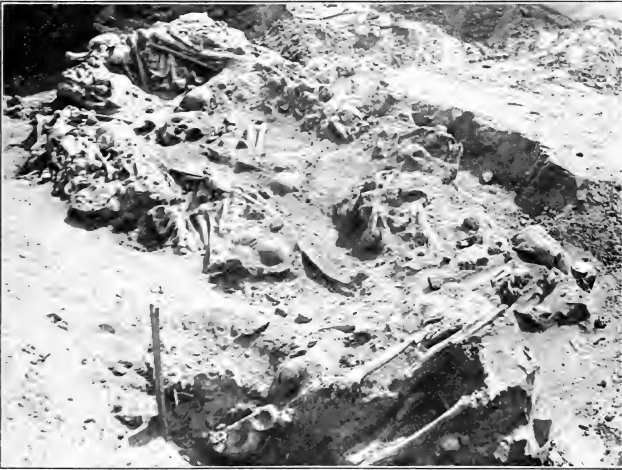

2



EXPLANATION OF PLATE XV.

Two views of the large ossuary of bundle re-burials found in the center of the conical burial mound, No. 1.

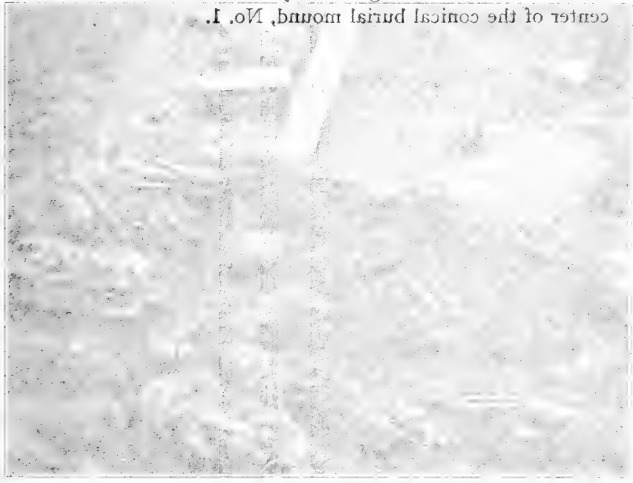

EXPLANATION OF PLATE XV.

Two views of the large ossuary of bundle re-burials found in the center of the conical burial mound, No. 1.



1



2



EXPLANATION OF PLATE XVI.

Figure 1. Skeleton of a burial in the flesh (No. 2) found in the large conical burial mound, No. 1.

Figure 2. Skeleton of a burial in the flesh (No. 3) found in the large conical burial mound, No. 1. This skeleton had five quartzite arrow points placed about its right knee.

Figure 3. The right knee of the skeleton shown in fig. 2 with the five arrow points in place.

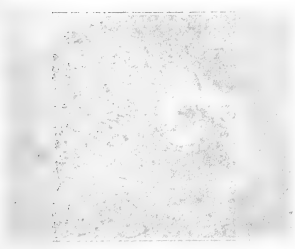

2



EXPLANATION OF PLATE XVI.

- Figure 1. Skeleton of a burial in the flesh (No. 2) found in the large conical burial mound, No. 1.
- Figure 2. Skeleton of a burial in the flesh (No. 3) found in the large conical burial mound, No. 1. This skeleton had five quartzite arrow points placed about its right knee.
- Figure 3. The right knee of the skeleton shown in fig. 2 with the five arrow points in place.



1

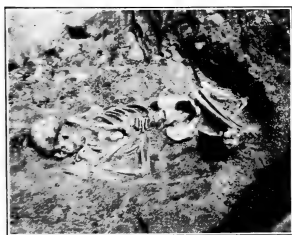

2

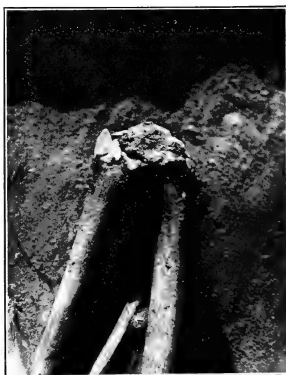

3

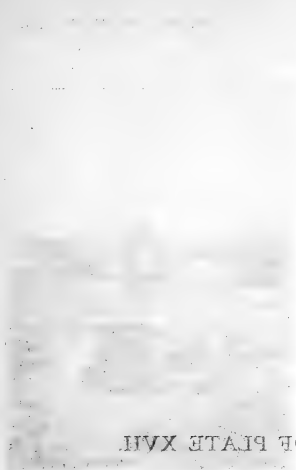

EXPLANATION OF PLATE XVII

Figure 1. Surveying the Kratz creek mound group.

Figure 2. General view of the excavation of the large conical burial mound, No. 1.

Figures 3 and 4. Methods of excavating the ossuary of bundle re-burials in the large conical mound, No. 1.

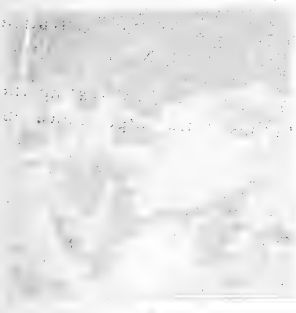

EXPLANATION OF PLATE XVII.

Figure 1. Surveying the Kratz creek mound group.

Figure 2. General view of the excavation of the large conical burial mound, No. 1.

Figures 3 and 4. Methods of excavating the ossuary of bundle reburials in the large conical mound, No. 1.



1



2



3

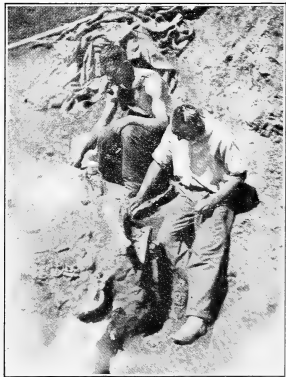

4

EXPLANATION OF PLATE XVIII.

- Figure 1. Crematory altar associated with pottery in a small conical burial mound, No. 50, in the Katsz Creek group.
- Figure 2. Fragmentary remains of a pot accompanying the crematory altar shown in plate IX, fig. 1, found in the panther effigy mound, No. 3.

EXPLANATION OF PLATE XVIII.

- Figure 1. Crematory altar associated with pottery in a small conical burial mound, No. 50, in the Kratz Creek group.
- Figure 2. Fragmentary remains of a pot accompanying the crematory altar shown in plate IX, fig. 1, found in the panther effigy mound, No. 3.



1



2

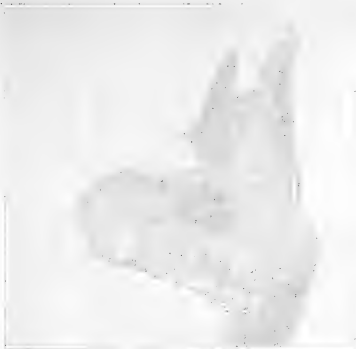

EXPLANATION OF PLATE XIX.

Three views of the right lobe of the pelvis of a man with a quartzite arrowhead imbedded in it. This came from the bottom of the mass of bundle re-burials in the center of the conical burial mound, No. 1.

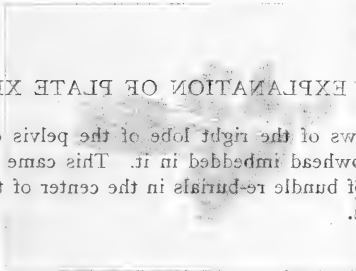

EXPLANATION OF PLATE XIX.

Three views of the right lobe of the pelvis of a man with a quartzite arrowhead imbedded in it. This came from the bottom of the mass of bundle re-burials in the center of the conical burial mound, No. 1.

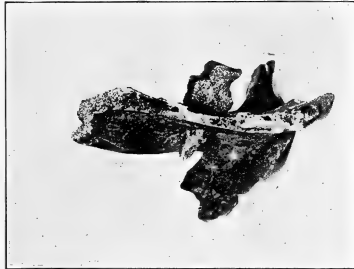

Museum, Mil-
N 25-1919
C
11

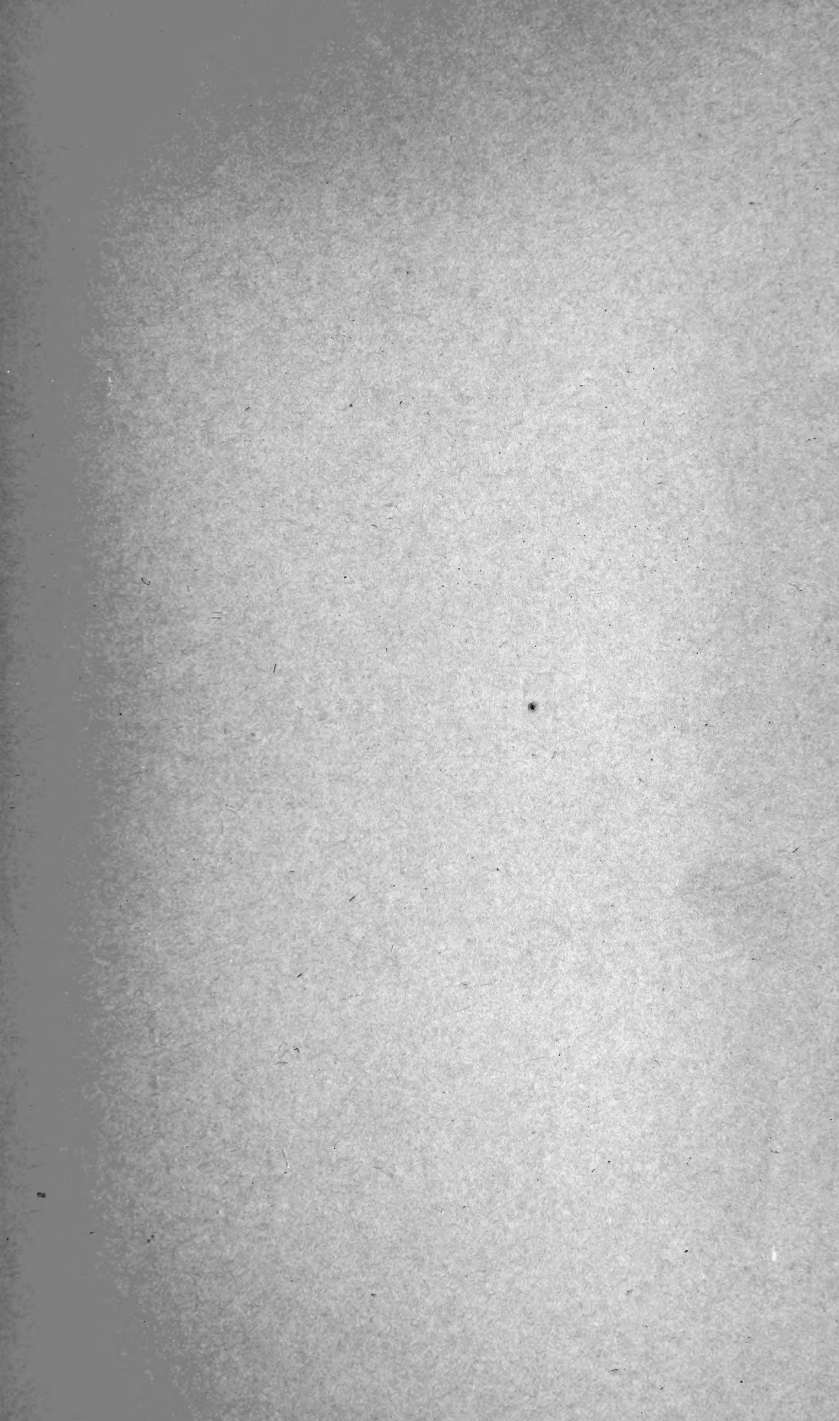



BULLETIN

OF THE

PUBLIC MUSEUM OF THE CITY OF MILWAUKEE

The Bulletin is sent in exchange for publications of the museums and other scientific institutions and societies with which such relations have been established.

Complete volumes or separate papers are also for sale at the Museum at the following prices which include postage.

- Vol. I. Complete Price, \$2.50
- Vol. I. Art. I. Catalogue of the Odonata of North America, by Richard A. Muttkowski. Pp. 1-208, May, 1910, Price, 1.25
- Vol. I. Art. II. Lolo Objects in the Public Museum, Milwaukee, by Frederick Starr. Pp. 209-220. Plates 1-8, July, 1911 Price, .25
- Vol. I. Art. III. Bees of Northern Wisconsin, by S. Graenicher. Pp. 221-250, November, 1911 Price, .25
- Vol. I. Art. IV. The Dream Dance of the Chippewa and Menominee Indians of Northern Wisconsin, by S. A. Barrett. Pp. 251-406, plates 9-25, November, 1911. Price, 1.25
- Vol. II. No. 1. The Washo Indians, by S. A. Barrett. Pp. 1-52, plates 1-13, map 1, text figures 1-22, May, 1917 Price, .50
- Vol. II. No. 2. Decorative Art and Basketry of the Cherokee, by Frank G. Speck. In press.
- Vol. III. No. 1. The Kratz Creek Mound Group, by S. A. Barrett and E. W. Hawkes. Pp. 1-138, plates 1-19, text figures 1-19, August, 1919 Price 1.00