



200

DK

PLATE I.



Map of North America, showing approximately the probable native home of the Rocky Mountain Locust; the country subject to invasion, and the eastern limit reached by it.—Prepared by C. V. Riley.

## EXPLANATION TO PLATE I.

---

Country in which the species is not indigenous ; which it visits at irregular intervals ; in which it is most disastrous ; and which it vacates within a year.

Area more often visited ; in which the species holds its own longer, but which it generally forsakes in the course of time.

Region where the species comes to perfection ; in which it permanently breeds ; and from which come the disastrous swarms that sweep over the first mentioned region.

Area west of the mountains where the species also, in all probability, breeds permanently ; from which it sometimes pushes to the east of the mountain range ; and from which the California swarms probably come.

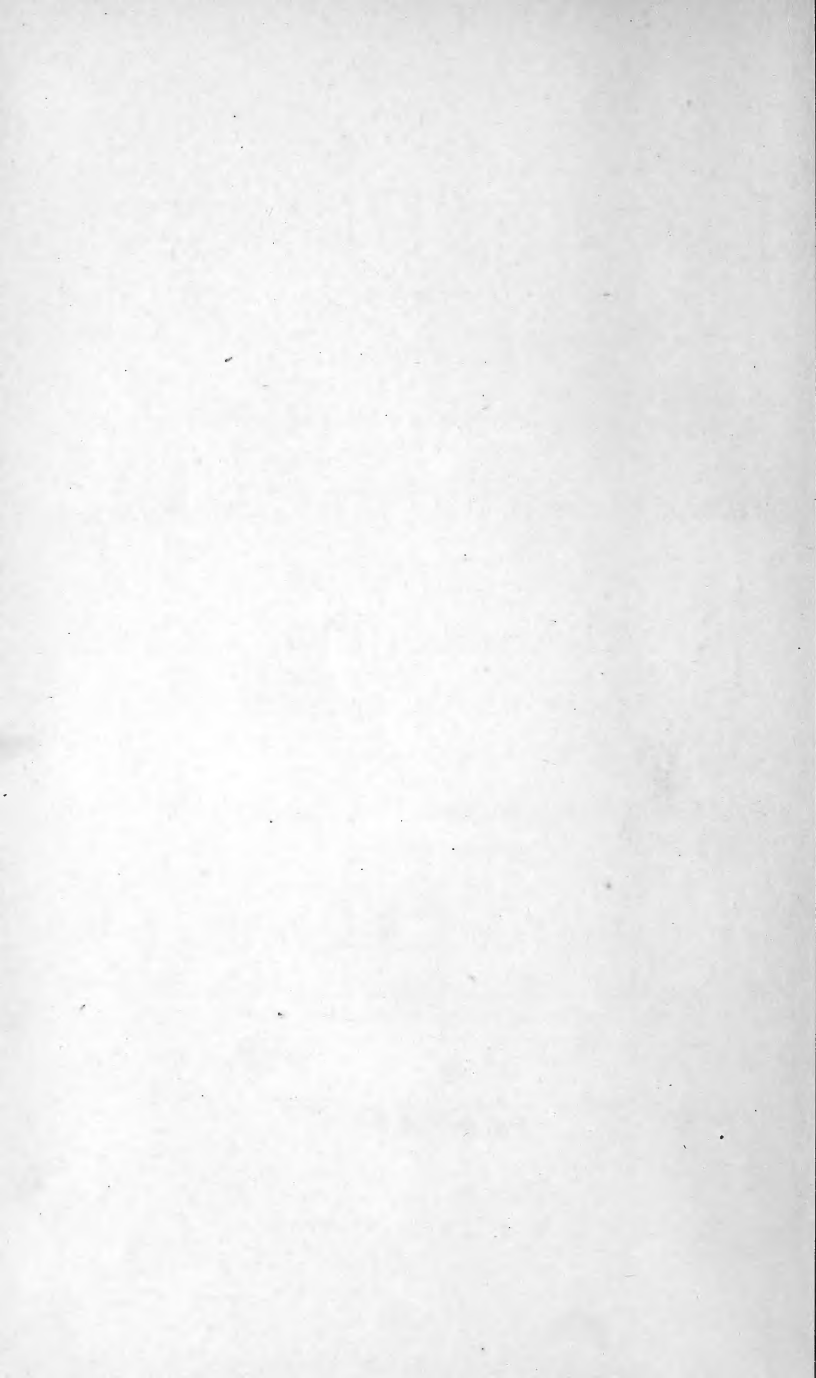

THE  
LOCUST PLAGUE

IN THE  
UNITED STATES:

BEING MORE PARTICULARLY A TREATISE ON THE

Rocky Mountain Locust

OR SO-CALLED

GRASSHOPPER,

AS IT OCCURS EAST OF THE ROCKY MOUNTAINS,

WITH

*Practical Recommendations for its Destruction.*

BY

CHARLES V. RILEY, M.A., PH. D.,

STATE ENTOMOLOGIST OF MISSOURI; CHIEF OF THE U. S. ENTOMOLOGICAL COMMISSION.  
LECTURER ON ENTOMOLOGY IN VARIOUS COLLEGES;  
AUTHOR OF "POTATO PESTS," ETC.

WITH 48 ILLUSTRATIONS.

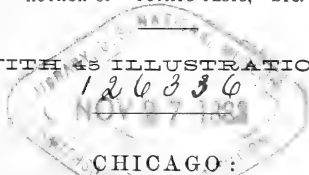

CHICAGO:  
RAND, McNALLY & CO., PUBLISHERS.

1877.

---

Entered according to the Act of Congress, in the year 1877, by

CHARLES V. RILEY,

In the office of the Librarian of Congress, at Washington, D. C.

---



# TABLE OF CONTENTS.

---

	PAGE
PREFACE . . . . .	7
INTRODUCTION . . . . .	9

## CHAPTER I.

CHARACTERS OF THE SPECIES . . . . .	13
-------------------------------------	----

Classificatory position of the Rocky Mountain Locust, 13.—How it differs from other species, 14.—Easily confounded with the common Red-legged Locust, 14.—Detailed descriptions of both, 15.—Its still closer resemblance to the Atlantic Migratory Locust, 22.—Characters of this last, 22.—Species *vs.* variety and race, 23.—Comparisons of these three closely-allied species in their early stages, 26.—A green variety of the Rocky Mountain Locust not infrequent, 27.—Purely an American insect, 28.

## CHAPTER II.

CHRONOLOGICAL HISTORY . . . . .	29
---------------------------------	----

The Locust plague in the "Old World," 29.—Extent of its injuries, 30.—Migratory species in Europe, Asia and Africa, 30.—The ravages of the locust in America, 31.—Its earliest visitations, 31.—Injuries on the Pacific Coast, 32.—Injuries east of the Rocky Mountains, 33.—Invasions of 1818-19, 33.—Of 1845-49, 34.—Of 1855, 34.—Of 1856, 35.—Of 1857-67, 35, 36.—Of 1866, 36.—Damage the following year, 37.—The invasion of 1873, 38.—That of 1874, 39.—Why so disastrous, 41.—General outlook in the spring of 1875, 42.—Severity of the injuries from the young insects that year, 43.—Destitution that prevailed, 44.—Amount of loss sustained, 45.—Destination of departing swarms of 1875, 47.—The invasion of 1876, 49.—Eastern limit reached, 53.—Omaha conference, 53.

CHAPTER III.		PAGE
NATIVE HOME AND GEOGRAPHICAL RANGE OF THE SPECIES EAST OF THE MOUNTAINS . . . . .		55
<p>Source of the devastating swarms that reach into the Mississippi Valley, 55.—Their origin in the extreme North-west country lying east of the mountains, 56.—Cause of their emigration, 57.—Difference between summer and fall swarms, 58.—The species not at home in the Mississippi Valley, 62.—Not permanent or able to perpetuate itself there, 62.—Conditions which prevent such permanence, 63.—Not likely to do serious harm east of the ninety-fourth meridian, 65.—Reasons why, 65.</p>		
CHAPTER IV.		
NATURAL HISTORY AND TRANSFORMATIONS . . . . .		69
<p>How the eggs are laid, 69.—Philosophy of the egg-mass, 71.—The female capable of laying more than one egg-mass, 72.—The escape of the young locust from the egg, 73.—Its emergence from the ground, 78.—Growth and transformations, 78.—Acquisition of wings, 80.—Number of molts, 82.—Flight at night, 83.</p>		
CHAPTER V.		
HABITS, AND POWER FOR INJURY . . . . .		85
<p>Flight and ravages, 85.—Migratory instinct and great destructive power confined to a single species west of the Mississippi, 88.—Food plants, 89.—Injury to fruit trees, 93.—Time of appearance of invading swarms, 94.—Rate at which they spread, 95.—Direction of their flight, 96.—Where the eggs are preferably laid, 96.—Time of hatching, 97.—Habits of the young or unfledged locusts, 98.—Directions in which the young travel, 100.—Rate at which they travel, 100.—Limit of their eastward spread, 100.—Not led by kings or queens, 101.—Direction taken by the departing swarms, 103.—Their destination, 104.</p>		
CHAPTER VI.		
EFFECTS OF THE YOUNG INSECTS IN THE COUNTRY WHERE THEY HATCH, BUT WHERE THEY ARE NOT INDIGENOUS . . . . .		107
<p>Experience with the young locusts in spring, 107.—Contrast in summer and fall, 108.—No evil without some compen-</p>		

sating good, 108.—Changes that follow the locusts, 109.—The prevalence of large green worms, 110.—The sudden appearance of a peculiar grass, 110.

CHAPTER VII.

NATURAL ENEMIES OF THE ROCKY MOUNTAIN LOCUST 113

Birds and other vertebrate animals, 113.—The good offices of birds, 113.—Invertebrate animals, 114.—Animals that attack the eggs, 115.—The Silky Mite, 115.—The *Anthomyia* Egg-parasite, 118.—The common Flesh-fly, 123.—Undetermined larvæ, 123.—Ichneumon-flies, Ground-beetles, Click-beetles and Myriapods, 126.—Insects that destroy the active locust, 126.—The Locust-mite, 128.—The Anonymous *Tachina*-fly, 131.—Yellow-tailed *Tachina*-fly, 134.—Flesh-fly, 135.

CHAPTER VIII.

PRACTICAL CONSIDERATIONS . . . . . 139

How best to prevent locust injuries, 139.—Encouragement of natural enemies, 139.—Destruction of the eggs, 139.—Experiments with the eggs, and conclusions drawn therefrom, 140.—Effects of alternately freezing and thawing, 141.—Influence of moisture, 143.—Exposure to the free air, 148.—Burying at different depths, and pressure of the soil, 149.—Table of temperatures, 152.—Harrowing in the fall, 153.—Collecting the eggs, 153.—Plowing; how most effectual, 153.—Irrigation, Tramping, 154.—Destruction of the young or unfledged Locusts, 155.—Burning, 155.—Crushing, 157.—Trapping, 157.—Ditching and trenching, 161.—Catching, 161.—Different contrivances for this purpose, 162.—Use of destructive agents, 162.—Coal-oil pans, 163.—The use of coal tar, 164.—The protection of plants by special applications, 165.—The best means of protecting fruit and shade trees, 166.—Sulphur fumes and smudges, 167.—Destruction of the winged locusts, 167.—Preventive measures, 169.—Suggestions that may prove of service, 170.—Use of hogs and poultry, 171.—The Signal Service, 172.—Military aid, 173.—Diversified agriculture, 174.—Organized effort, 176.—State legislation, 176.—Missouri locust-law, 177.—Kansas locust-laws, 178, 179.—Minnesota locust-law, 180.—Nebraska locust-law, 184.—How to avert locust invasions, 186.

## CHAPTER IX.

## RAVAGES OF LOCUSTS EAST OF THE MISSISSIPPI . . . 187

PAGE

Migratory Locusts in the Eastern States, 187.—The Atlantic Locust, 187.—Injury from other, non-migratory species, 190.—Often a serious matter during hot, dry seasons, 193.—Locust flights in Illinois in 1875, 195.—The species of which the swarms were composed, 197.—Locust flights east of the Mississippi not composed of the Rocky Mountain species, 201.—Necessity of discriminating between species, 201.

## CHAPTER X.

## GENERAL CONSIDERATIONS . . . . . 207

Nomenclature, 207. — Locust *vs.* Grasshopper, 207.—Prairie fires *vs.* locust ravages, 209.—Fasting and prayer, 213.—Not a divine visitation, 216.—Influence of the wind in determining the course of locust flights, 216.—Locusts as food for man, 217.—Unnecessary alarm caused by comparatively harmless species, 227.

## PREFACE.

---

THE author has been frequently urged by those who have been interested in, or who have profited by his writings, to republish, in compact form, the articles that have appeared in the Missouri Entomological Reports, on the subject of the Rocky Mountain Locust. The work herewith submitted to the public is the result. It is simply an orderly bringing together and revision of the matter contained in sundry fugitive articles, and particularly of that in the Seventh, Eighth and Ninth Reports aforementioned, which have no circulation outside of Missouri. It could not well have appeared without the kind assistance of Prof. O. S. Westcott, of the High School, Chicago, to whom the writer is under obligations for superintending the details of publication during his constant absence in the field, in the performance of Government duty.

Trusting that the work will interest both the popular and the scientific reader, certain descriptive passages, of more especial concern to the naturalist, have not been excluded, but are printed in smaller type than the text, so that they may be skipped by

the farmer, or by others who do not care for such details. These will be found principally in the first chapter. Except where necessary, for the sake of precision, technicalities have been avoided. The term "larva," frequently employed, means the young or second state of an insect—that succeeding the egg; and the term "pupa" means the third state, or that preceding the perfect or mature form. In most insects, the larva is vermiform, and totally unlike the parent, while the pupa is dormant or quiescent. In the locust, however, the change from one state to another is gradual, and the pupa is active.

The sign ♂ wherever used, indicates "male;" the sign ♀ "female." The illustrations are from nature by the author, unless otherwise stated, and where enlarged, the natural size is usually given in hair-line. The facts and recommendations are the result of extensive personal experience, and that they may prove of benefit to the large class which suffers from locust injuries, is the earnest desire of

THE AUTHOR.

ST. LOUIS, MO., May 15th, 1877.

## INTRODUCTION.

---

No insect has ever occupied a larger share of public attention in North America, or more injuriously affected our greatest national interest, than the subject of this treatise. Especially during the past four years has it brought ruin and destitution to thousands of our Western farmers, and it constitutes to-day the greatest obstacle to the settlement of much of the fertile country between the Mississippi and the Rocky Mountains. Knowledge is power in protecting our crops against the ravages of a tiny insect, as in all other undertakings ; and according as accurate knowledge regarding this locust plague is disseminated among our people, will they be able to vanquish the common foe.

It is a gratifying evidence of the progressive character of our Republic, that the late Congress made provision for a Commission, the duty of which is to make a thorough survey of this locust subject, with a view of enabling our people to protect their crops against the insect's attacks, and, if possible, prevent its incursions from its native breeding grounds. The task is a great one, and the good

that will flow from the labors of the Commission will, let us hope, be correspondingly great.

The history of this Migratory Locust, east of the Rocky Mountain range, as recorded in the following pages, presents certain marked features. We have, first, the migrations of winged swarms in autumn, from the mountain regions of the West and Northwest, into the more fertile country south of the 44th parallel and east of the 100th meridian; second, the return migration of the progeny, as soon as wings are acquired the next summer. It is the more fertile and thickly settled country south and east of the limits indicated, which suffers most, both from the insects that sweep over it, and from the young that hatch in its rich soil; and it is principally this country which, in this work, is designated as outside the insect's native home, and in which it can never become a permanent resident. The species does not dwell permanently even in much of the country north and west of those lines, but it flourishes more and more toward the Saskatchewan, Swan River and Red River Settlements of British America, and westward therefrom.

Another marked feature is the eastern limit of the insect's spread, at a line broadly indicated by the 94th meridian, and the consequent security from serious injury east of that line. These three



---

features — the Northwest origin, the return migration from the Southeast country (which implies only temporary injury therein), and the Eastern limit — may be stated as laws governing the insect east of the Rocky Mountains. They were first fully propounded by the writer, and will, he believes, be fully established and confirmed by future events. Their general truth is a guarantee to the people of the Mississippi Valley against continued injury from locust ravages, and should banish from the minds of the farmers east of the great “Father of Waters,” the fear of being visited by the disastrous locust armies.

One other point is, also, made clear in the following pages, viz., that in the more thickly settled parts of the country subject to visitation, man has the power to utterly rout, by practical and feasible means, the young or unfledged insects. Indeed, when our people become familiar with the locust plague in all its phases, it will cease to be such a bugbear. There is no part of the country that is not subject to meteorological or entomological excesses, and in the long run the Rocky Mountain Locust is not more injurious in the country which it occasionally visits, than are some of the farmer’s insect foes, in other parts of the country. When we think of the famine and utter destitution that at

times overtake some of the Eastern peoples, we may well feel grateful that we live in a land of such resources and promise. The threatened country is, in the main, one of the most fertile regions on the face of the globe. It has prospered in the past : it will prosper in the future ; and in proportion as we meet this locust enemy with enterprise and concerted, intelligent action, in that proportion shall we vanquish it.

# THE ROCKY MOUNTAIN LOCUST.

---

## CHAPTER I.

---

### CHARACTERS OF THE SPECIES.

THE Rocky Mountain Locust belongs to the Order of Straight-winged Insects (*Orthoptera*), and to the Family *Locustidæ*, Westwood.\* It is the *Caloptenus spretus* of Thomas,† and comes to perfection only in the plains regions of the Rocky Mountains and of the Northwest.

#### EASILY CONFOUNDED WITH THE RED-LEGGED LOCUST.

The western farmer is too familiar with the insect under consideration to need any detailed description of it. Yet this work will doubtless come into the hands of many who have yet formed no personal acquaintance with the pest, but who nevertheless, for one reason or another, desire to become familiar with its appearance. There are also several allied species which are apt to be confounded with it,

---

\* *Acridii*, Latreille.

† The species was named in MS. by Mr. P. R. Uhler, of Baltimore, Md., but never by him described. Mr. B. D. Walsh subsequently (*Practical Entomologist*, II, p. 1,) adopted Mr. Uhler's name in connection with a partial description; but Mr. Thomas first fully defined the species, as here distinguished and referred to by me.

and two of these I desire to call special attention to, because they are widespread and common. So at the outset the reader will be served with some rather dry details, and if such be not palatable, he is advised to pass to other chapters that may interest him more.

In my endeavors to accurately map out the territory in Missouri invaded in 1874 by the Rocky Mountain Locust, I was frequently puzzled by accounts from counties east of the limit-line beyond which, as I shall show in Chapter VI, it never reaches to do harm. In every such instance, where I was able to obtain specimens, they proved to be

[Fig. 1.]



RED-LEGGED LOCUST.

the common Red-legged Locust. This last species is common in most of the States, extending to the Atlantic, and is even reported in parts of the Rocky Mountain region, where the migratory species is at home. The two bear such a close general resemblance that even entomologists have doubted their specific distinctness; and indeed size and colorational characters would not suffice to separate the exceptional individuals which depart most from the typical characters of their species, and approach most to those of the other.

[Fig. 2.]



ROCKY MOUNTAIN LOCUST.

Yet they are distinct, as species go, and in order to properly study the distribution of the Rocky Mountain species, and its power of becoming acclimated in the Mississippi Valley, or not, it is of the first importance that observers confound not the two species. Hence, I shall describe in detail the two insects. From these details, which follow in smaller type, it is evident that the distinguishing characters, most easily observed by the non-entomologist, are the relative length

of wing, and the structure of the terminal joint of the male abdomen, which is turned up like the prow of a

[Fig. 3.]



ROCKY MOUNTAIN LOCUST:—Anal characters of male; a, side view; b, c, hind and top views, of tip.

ship—this last character being the

most important and constant.

The Rocky Mountain species has the wings extending, when closed, about

[Fig. 4.]



RED-LEGGED LOCUST:—Anal characters of male; a, side view; b, c, hind and top views, of tip.

one-third their length beyond the tip of the abdomen (Fig. 2), and the last or upturned joint of the abdomen narrowing like the prow of a canoe, and notched or produced into two tubercles at top (Fig. 3). The wings of the Red-legged Locust extend, on a average, about one-sixth their length beyond the tip of the abdomen (Fig. 1), and the last abdominal joint is shorter, broader, more squarely cut off at top, without terminal tubercles, and looks more like the stern of a barge (Fig. 4).

DESCRIPTIVE: DETAILED COMPARISONS WITH THE RED-LEGGED LOCUST.

A large amount of material examined, has enabled me to make very thorough comparisons between the two species. The genus *Caloptenus* to which the species belongs, is distinguished principally by the stoutness of the spine-like tubercle on the fore-breast between the front legs, and by the tip of the abdomen in the male being much swollen. Mr. Cyrus Thomas, in his admirable work on the "Acrididæ of N. A." has published good descriptions of the known N. A. species, and I will transfer what he has said of the two in question—adding only some subsidiary remarks in brackets, and at the close :

*CALOPTENUS FEMUR-RUBRUM*, Burm. Handb. Ent., II, 638.

Syn. *Acridium femur-rubrum*, Deg. Ins. III, Pl. 42, Fig. 5, p. 498.

" *femorale*, Oliv., Encyl. Meth., 121 Ins. VI, 228.

*Gryllus (Locusta) erythropus*, Gmel., Linn. Syst. Nat. I, IV, 2086.

"Grizzled with dirty olive and brown; a black spot extending from the eyes along the sides of the thorax; [but never upon the

third lobe]; an oblique yellow line on each side of the body beneath the wings; a row of dusky, brown spots along the middle of the wing-covers; and the hindmost shanks and feet blood-red, with black spines. The wings are transparent, with a very pale greenish-yellow tint next to the body, and are netted with brown lines. The hindmost thighs have two large spots on the upper side, and the extremity black [more correctly three such spots, or, including the extreme one at tip, four: Harris seems to have overlooked the basal one]; but are red below, and yellow on the inside. The appendages at the tip of the body in the male are of a long triangular form. Length [to tip of abdomen] from 0.75 to 1 inch; expansion of wings 1.25 to 1.75 inches." As this species, which is so common, varies considerably, I have concluded to give Dr. Harris's description without change, adding the following: Vertex but slightly depressed, with a minute angular expansion in front of the eyes; frontal costa usually but slightly sulcate; sides parallel. Eyes large and rather prominent. Elytra and wings generally a little [usually extending about 1-6 their length beyond the abdomen] longer than the abdomen. The cerci of the male rather broad and flat [longer and narrower toward tip than in *spretus*]; apex of last ventral segment entire and truncate. The yellow stripes on the side extend from the base of the wing to the insertion of the posterior femora. The ground color varies with localities and age, and most of the specimens from one or two sections appear to have unspotted elytra; sometimes a reddish-brown tint prevails; at others a dark olive; at others a dark purplish-brown; yet the markings generally remain the same.

*Localities.*—Maine, Massachusetts, Connecticut, New York, Pennsylvania, Maryland, Tennessee, Illinois, Minnesota, Ohio, Nebraska, Missouri, Kansas, Colorado, Wyoming, Vancouver's Island (?), west coast of America (?).—[Thomas, *Acrididae* of N. A. (1873), pp. 163-4.

In addition to what Mr. Thomas states of the variation in color, it may be added that the dark marks on the hind thighs are in exceptional specimens wholly wanting, and in others so confluent that the whole of the upper part is brown-black. In order to show how variable (within certain limits, however,) is the relative length of wing, I have made measurements of over two hundred specimens, all taken in St. Louis county, Mo. As the length of the abdomen is an uncertain criterion, varying according as this last is distended with eggs or contracted from one cause and another, I have made these measurements from the juncture of the hind thighs and shanks. The specimens were killed in the cyanide bottle, and while yet fresh and supple laid flat on a scale divided into hundredths of an inch. The furthest hind leg was then stretched until the suture between shank and thigh was just visible above the inner border of the front wings. Careful measurements were then

taken, first, of the whole body; second, of the extent of wing beyond the base of shank; third, of the extent of abdomen beyond the same. In the table below, only the extremes and the average of these measurements are given. It should be observed that as the abdomen shrinks slightly in drying, and the wings do not, the figures in the fourth column are somewhat lower than if taken from dry specimens. This table of measurements will prove interesting when compared with that further on, giving similar measurements of *spretus*, and will conclusively show, by comparing the figures in the fourth column, that the specific distinction can not, as Mr. Walsh thought, be safely and solely left to length of wing beyond the abdomen; as specimens of either species may in this respect approach very near each other, and in exceptional cases entirely agree. Nevertheless, this relative length of wing has great value as a specific character, inasmuch as the difference in relative length is the rule, while the converse is a rare exception. The anal characters of the male, (Fig. 4) will be found pretty constant and reliable. Yet they also vary and frequently approach *spretus* in the narrowing notched form of the tip. In the female the anal characters are of less value in distinguishing the species.

CALOPTENUS FEMUR-RUBRUM.

Measurements of the Male; in Hundredths of an Inch.

	Whole length from front of head to tip of wing.	Length of wing beyond base of tibia.	Length of abdomen beyond base of tibia.	Length of wing beyond tip of abdomen.
Lowest.....	0.94	0.02	0.00	0.00
Highest.....	1.12	0.12	0.08	0.08
Average.....	1.03	0.08	0.03	0.03

Measurements of Female.

Lowest.....	1.03	0.02	0.00	0.00
Highest.....	1.22	0.15	0.15	0.12
Average.....	1.15	0.08	0.08	0.04

CALOPTENUS SPRETUS, Uhler Mss.

Syn., *Acridium spretum*,\* Thomas Trans. Ill. St. Agr. Soc., V, 450.

Very much like *C. femur-rubrum*, Burm., the principal difference being in the length of the elytra and wings; a notch at the

\* This is called "*Acridium spretis*, Uhler" in the article alluded to, and I very much doubt if the description refers to the species in question; first, because I do

tip of the last [ $\delta$ ] ventral segment. Posterior lobe of the pronotum slightly expanding; median somewhat distinct. Elytra and wings pass the abdomen about one-third their length. The last [ $\delta$ ] ventral segment, which is turned up almost vertically, is somewhat tapering and is notched at the apex, which distinguishes it from the *femur-rubrum*; the notch is small, but is distinct. Prosternal spine robust, subcylindrical, transverse. Migratory.

*Color.*—Scarcely distinct from the *C. femur-rubrum*. The occiput and disk of the pronotum generally reddish-brown; the posterior lobe somewhat paler than the anterior and middle. Spots, as in *femur-rubrum*, arranged in a line along the middle of the elytra; these are a little larger and more abundant toward the apex. The head and thorax are sometimes a very dark olive-brown, at others, reddish-brown, and even brownish-yellow, the color deepening with age. The wings are pellucid, nerves dusky toward the apex; when flying high and against the sun, the wings look like large snow flakes.

*Dimensions.*—♀ Length [to tip of abdomen], 1 to 1.2 inches; elytra as long as the body; posterior femora, 0.55 inch; posterior tibiæ, 0.5 inch. ♂ Length, 0.85 to 1 inch; elytra, 0.9 to 1.05 inches.

As with *femur-rubrum*, the color of *spretus* is quite variable, and the dead specimens, from which Mr. Thomas's description is evidently made, convey a very imperfect idea of the living colors. In the fresh or newly fledged specimens the colors, taken from my notes in the field, are as follows: The more common specimens are yellowish-white beneath; glaucous across the breast and about mouth-parts; pale bluish-glaucous, often with shades of purple and ferruginous, on the sides of the head and thorax, and the upper front of the face, which is sparsely and shallowly punctate and faintly mottled with fuscous; olive-brown and rust-red on the occiput and pronotum—the rust-red relieved along the middle in the following characteristic marks: two stripes on occiput, diverging from between the eyes, and a very narrow median line—the brown relieving them in a series of transverse mottlings; a broad shade on anterior lobes of pronotum, narrowing posteriorly and intersected by black along the median carina, and the three transverse sutures;

---

not believe that *spretus* occurs in Murphysboro, Ill., where Mr. Thomas was then residing, and where he quotes *Acridium spretis* as being quite common; secondly, because the description in some respects would not apply to *spretus* as at present defined. I call attention to this discrepancy, because it is upon this (as I believe erroneous) reference, that Mr. Thomas quotes *spretus* from Illinois; whereas I agree with Mr. Walsh that (as we understand the species to-day) it is not indigenous to that State. Where the anal characters of the male are not carefully given, it is impossible to be sure of the species. Mr. Thomas himself now believes that he must have had before him what is defined further on as *Atlanis*.



and, finally, a narrower shade on the posterior lobe, dilating posteriorly and also with a black medial line along the carina. The abdomen is pale, inclining to yellow, beneath; more or less bluish, or lilaceous above and marked with black especially toward base: it also shows more or less distinctly the pale lines and mottlings mentioned further on in the description of the pupa in which they are more distinct. These are in a general way, two pale longitudinal lines, diminishing anally, one subdorsal with an inferior coincident spot on each joint; the other stigmatal, twice as broad, with an oblique dark mark dividing each joint, besides other smaller and less distinct spots and mottlings. In the male the anal parts are pale. The front wings, when closed, present a ground color of pale grayish-yellow, inclining to olivaceous: they are generally yellowish at base and the inner or dorsal surface is more or less ferruginous: there is a characteristic whitish-yellow medial shade along the basal half, rendering more conspicuous the larger spots of which there are about a dozen, irregularly arranged, some of the middle ones being usually confluent: when open, the wing is seen to be pellucid toward tip; more opaque basally owing to the increase of the reticulate veins, which are brown-black toward tip and yellow outwardly, whitish-yellow medially, and ferruginous inwardly, toward base: the small spots are brown, the larger black. The hind wings, except a yellowish or brownish shade at apex and along front edge, and a greenish tint at base, are transparent and colorless, with the larger veins on the outside brown-black, and the inner ones pale. The front and middle legs are yellowish, inclining to red, the middle thighs with slight dusky shades outside and at tip. The hind legs have the thighs striped with pale glaucous and reddish on the outside and upper half of inside and four black or dusky marks on the upper edge, especially inside, the basal smallest and the terminal one largest and extending beneath around the knee; the inferior groove is generally yellowish and the transverse v-shaped and two longitudinal ridges on the outside, are whitish-yellow: the shanks are coral-red with black spines; the feet somewhat paler, with black claws. The antennæ are pale yellow, or brownish, tipped with pale annuli; generally darkest toward tip. The eyes are dark olivaceous, and the ocelli (one at anterior front of each eye, and one in the sulcate depression of frontal costa) brown, with a black and a white border.

Besides the black on wings and legs already mentioned, there

are the following characteristic black marks : an annulus near tips of palpi, the inner borders of the mandibles, a spot at the upper outer corner of clypeus, a spot running narrowly around hind border of eyes and then from about the middle of the eye, broadening to thorax; a broad patch on the upper side of anterior half of prothorax, zig-zag beneath, and enclosing two pale subquadrate spots, the upper anterior one across the second suture, the lower one between the second and third sutures; finally, more or less distinct lines along and around the meso- and meta-thoracic sutures.

There is also a conspicuous pale yellow mark bordering superiorly the black stripe behind the eyes, the black of prothorax inferiorly, at outer base of front wings, from this to base of hind thighs and around bases of both middle and hind thighs.

*In the dead specimens all these colors become more dingy and yellow.* Palpi and front legs in some specimens tinged with red or blue; the hind tibiae sometimes yellowish instead of red, especially in the middle; at other times bluish.

*Larva.*—When newly hatched, the larva is of a uniform pale gray without distinctive marks. It soon, however, becomes mottled with the characteristic marks. After the first molt the hind thighs are conspicuously marked on the upper outside with a longitudinal black line; the thorax is dark with the median dorsal carina and two distinct lateral stripes pale yellow, the black extending on the head behind the eyes. The sides of the thorax then become more yellow with each molt, the black on the hind thighs less pronounced, and the face almost always black. The occiput and abdomen above are mottled with brown, the former marked with a fine median, and two broader anteriorly converging pale lines, the latter with two rather broken lateral lines of the same color.

*Pupa.*—The pupa is characterized by its paler, more yellow color, bringing more strongly into relief the black on the upper part of the thorax and behind the eyes; by the spotted nature of the face, especially along the ridges, the black being less persistent; by the isolation of the black subdorsal mark on the two anterior lobes of the prothorax, and by the large size of the wing-pads, which are now dark, with a distinct pale discal spot, and pale veins and borders. The hind shanks incline to bluish rather than red as in the mature insect. The ground-color in the immature states varies from pale yellow to orange-brown and even black, and from pale yellow to pure green, as in the variety *viridis*. In many of the

larvæ there is a distinct pale line along the medio-dorsum; in others there is no trace of it.

In the following table of measurements, introduced for comparison with that given of *femur-rubrum*, the same rules were adopted as in the other case, and particular pains were taken to get specimens from as many parts of the ravaged country as possible; also, by study of the structural and other peculiarities of *spretus* to guard against the chance mixing of specimens of *femur-rubrum*.

CALOPTENUS SPRETUS.

Measurements of the Male; in Hundredths of an Inch.

	Whole length from front of head to tip of wing.	Length of wing beyond base of tibia.	Length of abdomen beyond base of tibia.	Length of wing beyond tip of abdomen.
Lowest.....	1.10	0.25	0.02	0.20
Highest.....	1.40	0.43	0.12	0.39
Average.....	1.28	0.34	0.05	0.31

Measurements of Female.

Lowest.....	1.15	0.28	0.04	0.13
Highest.....	1.53	0.52	0.19	0.39
Average.....	1.35	0.35	0.10	0.27

Finally, besides the structural and more reliable characters already given, the two species may, in general terms, be distinguished by the following less reliable and more inconstant characters as presented in cabinet specimens: *Spretus* is the larger species; the antennæ are slightly shorter and paler; the occiput and two anterior lobes of the prothorax are more livid and darker; the third lobe of prothorax broader; the dark, subdorsal, prothoracic mark running from the eyes less pronounced; the oblique, yellow line from base of wings to base of hind thighs more often obsolete; the front wings paler toward tips, more ferruginous at base, with larger, more conspicuous spots; the anal abdominal joint of male also much paler; the cerci and valves in the female generally shorter and more robust.

In *femur-rubrum* the general hue is more olivaceous and darker, the black mark behind eyes is broader, and that on prothorax also broader, more straight beneath, and seldom enclosing white marks; the pale stripe from base of wing to hind thighs is more conspicuous and the spots on wings subobsolete.

Such are the distinguishing features between these two insects,

when the more typical specimens of the western *spretus* are compared with *femur-rubrum* as it occurs around St. Louis. That these distinguishing features will lose their value in proportion as abundant material from all parts of the country is examined and compared, I have not the least doubt; for I have already shown that such is the fact so far as coloration and length of wing is concerned, and the meagre material which I have from the East indicates considerable variation and approach in the more important structural characters.

A THIRD, CLOSELY RELATED SPECIES WHICH IS EASILY  
CONFOUNDED WITH THE OTHER TWO.

There is still a third species common in the Mississippi Valley, and particularly along the Atlantic coast, and in the New England States. It is smaller than either the Rocky Mountain or the Red-legged species, but in structure and relative length of wing much more nearly resembles the former than the latter; in other words, its relative length of wing enables it to fly with almost the same facility as its Rocky Mountain congener. This species I have called the Atlantic Migratory Locust, and it is described below, in comparison with its close allies:

CALOPTENUS ATLANIS, RILEY.—Length to tip of abdomen, 0.70—0.85 inch; to tip of closed wings, 0.92—1.05 inches. At once distinguished from *femur-rubrum* by the notched character of the anal abdominal joint in the male and by the shorter, less tapering cerci; also by the greater relative length of wings which extend, on an average, nearly one-third their length beyond the tip of the abdomen, in the dried specimens; also by the larger and more distinct spots on the wings—in all which characters it much more closely resembles *spretus* than *femur-rubrum*. From *spretus*, again, it is at once distinguished by the smaller size, the more distinct separation of the dark mark running from the eyes on the prothorax and of the pale line from base of wings to hind thigh; also by the anal joint in the ♂, tapering more suddenly and by the two lobes forming the notch being less marked; also by the pale marks on the outside of hind thighs being much more distinctly relieved. From both species it is distinguished not only by its smaller size

but by the deeper, more livid color of the dark parts, and the paler yellow of the light parts—the colors thus more strongly contrasting.

Just as the typical *femur-rubrum* is at once distinguished from the typical *spretus* by the characters indicated ; so *Atlantis*, though structurally nearer to *spretus*, is distinguished from it at a glance by its much smaller size and darker, more marbled coloring. The contrast is all the greater in the living specimens, and I have seen no specimens of *spretus* that at all approach it in these respects.

Whether this is the *femur-rubrum* as defined by DeGeer or by Harris, it is almost impossible to decide, though Harris's figure of *femur-rubrum* better represents it than the true *femur-rubrum*, as subsequently defined by Thomas, and as found in Illinois and Missouri.

It has always been a question among orthopterists, whether *spretus* should be considered specifically distinct from *femur-rubrum*, and Mr. Uhler has himself expressed to me his doubts as to the two being distinct. This indecision, which I myself very freely shared, may be attributed principally to the fact that the species just described (*Atlantis*) has very generally been mistaken for *femur-rubrum*, and that the accounts of this latter rising into the air in swarms have in reality had reference to the former species. The only reference to this longer-winged species, in the East, that I am acquainted with, is that by Dr. A. S. Packard, Jr., whose mention of the occurrence of *spretus* in Maine and Massachusetts, as exhibited by specimens in the museum of the Peabody Academy of Science, (*Am. Naturalist*, Vol. VIII, p. 502), refers to this species, as I have ascertained by specimens submitted to me. This *Atlantis* as it occurs in the Mississippi Valley, varies somewhat from the typical form as found in the mountain regions of the Atlantic, being somewhat larger. It is found with *femur-rubrum* in varying proportions, sometimes predominating, at others in small numbers, or

entirely absent. As a rule it is most abundant on open prairies, and in spring and summer is always found in such situations. It matures rather later than *spretus*, in the same latitude but earlier than *femur-rubrum*, which is not at all infrequent in timber.

Whether these three insects, as here defined, are really distinct species, or only races of one and the same, is a question that each individual entomologist will decide for himself, according to his idea of what constitutes a species. All discussion at the present day as to whether we are dealing with species or varieties in the lower classes of animals, is more or less puerile. Naturalists have no fixed standard as to what constitutes a species, and are fast coming to the conviction that there is no such thing in nature, and that the term is conventional—an abstract conception. Yet it is the custom, in entomology and botany more particularly, to separate by names, under this term species, forms that are separable and show constant differences; and the separation of such by the study of large material, and their life-histories is of far more weight and value than that by the examination and description, however detailed, of one or two individuals. As ordinary distinctions go, however, there can be no doubt as to the specific distinctness of these three forms, notwithstanding my own conviction that they merge into one another through exceptional intermediate individuals. I have little doubt that they will cross with each other and produce fertile progeny, just as many species of plants are known to do; but such crossing, if it occurs, must be more frequent between *femur-rubrum* and *Atlantis* than between either of these and *spretus*; because this last is the most effectually separated geographically—a fact proved alike by its dying out east of the 94th meridian, and by its perishing when

---

artificially transported in the egg and hatched in the Atlantic States.\*

It is in this, as it is in almost every other instance where large material from widely different parts of the country is examined ; the lines which are easily drawn between species characterized from single individuals, break down, and continually remind us of the arbitrary nature of specific definitions, and of the fact that most of the species, as defined among lower animals and plants, have no real existence in nature. There are races of *femur-rubrum* which approach even the larger *differentialis* as much as they approach *spretus*. In short, without speculating on the common origin, in the past, of all these species—and, indeed, of all species composing present genera—we behold, in a broad sense, a short-winged species (*femur-rubrum*) common to the whole country between the Rocky Mountains and the Atlantic, giving way, in the higher altitudes alike of the Rocky Mountain and the White Mountain, and probably of the Alleghany regions, to a long-winged one ; and the reason why the western long-winged species is more disastrous than that of the East, is doubtless due to its larger size and to the larger extent of table land in which it breeds, as well as to the fact that the western climate is more subject to excessive drouths, which cut off the supply of nourishment at a time when the insects are acquiring wings, and thus oblige them to migrate—such conditions occurring much more rarely in the home of the eastern species. In the lower country on either side of the Mississippi, the typical characters of the three species are more liable to vary and to approach one another. The future orthopterist, as he studies material from all parts

---

\* See an observation by Mr. S. S. Rathvon, of Lancaster, Pa., who concludes from experiment, that the climate there is "unwholesome" to the species. (*Am. Entomologist*, II, p. 88.)

of the country, will very likely write : *Caloptenus femur-rubrum*, DeGeer, var. *spretus*, Thomas, var. *Atlanis*, Riley; but the broad fact will remain that these three forms—call them races, varieties, species, or what we will—are separable, and that they each have their own peculiar habits and destiny.

COMPARISONS OF THE THREE ALLIED SPECIES IN THEIR  
EARLY STAGES.

Comparisons of the immature stages of these three species show that, when large material is examined, *femur-rubrum* and *Atlanis* are more nearly allied than this last and *spretus*, though, as in the mature insects, they approach each other through exceptional individuals.

In the first stage, *spretus* has a decidedly ferocious look, the head being out of all proportion to the rest of the body. The colors are brown, gray and dull white, the general tint being light gray, and the insect presenting a mottled and speckled appearance. The antennæ have several joints less than when mature, and are more thick and clavate. The frontal ridge is more prominent and deeply sulcate. The cerci extend beyond the rounded tip of the abdomen. The tarsi show the three joints, but the middle one less distinctly than afterwards. The medio-dorsum from vertex to near the tip of the abdomen, is carinate and pale. Of the dark dots and marks the most conspicuous and persistent (for some specimens are much darker than others) are, one behind the eyes, a subquadrate one on the side of the meta-thorax, a crescent streak on the sides of the swollen end of the hind femora, and two spots on the bulbous base of the hind tibiæ. In the second stage the face with very rare exceptions is pitchy black, the top of the head showing the three characteristic rows of transverse black marks on a rust-brown ground, the outer rows curving around the eyes, and the middle one broadest and divided by a narrow medial, pale line; the rust-brown color continues, with more irregular black marks on the prothorax, narrowing toward its middle; on each side of it the anterior part of the prothorax is black, relieved below by a conspicuous, arched pale line, and this again with a more or less distinct dark lateral mark beneath. The cheeks are mottled with rust-brown and edged behind with yellow; the head beneath, and palpi, except a black rim around tips, are pale yellowish. The other colors are much as



in the mature insects. With each succeeding stage the broad and pale streaks of prothorax intensify, and as soon as the hind wing-pads are turned up over the front pair, viz., in the fourth stage, the pale spot at the base which becomes so conspicuous in the pupa, is visible. The black face after the first molt is quite characteristic, and often endures to the pupa state.

*Atlanis*, in the first stage, is distinguished by its deeper, more livid, or rosy, less speckled appearance, and more strongly contrasting brighter yellow venter. In the subsequent stages these colorational differences still prevail, and the face is not black as in *spretus*; the pale spot on the hind wing-pads is less conspicuous in the fourth stage, and the pupa is distinguished not only by its smaller size and different color, but by the narrower, more obsolete black marks of the prothorax and by the wing-pads being considerably shorter and smaller, the hind pair livid, with only rarely a touch of black at base, and with the pale spot obsolete. The pale streaks on the outside of the hind thighs are always conspicuous. It presents in fact a marked contrast to the pupa of *spretus*.

*Femur-rubrum*, in the early stages, is distinguished by the generally paler, less livid and greener hue; by the black being more intense and contrasting more with the pale colors; by the wing-pads having no pale spot, and by the outer black mark on hind thighs showing no pale streaks.

*Spretus*, though palest when mature, has altogether the largest amount of black in the immature stages, and notwithstanding the osculant individuals, one who has great familiarity with these three species in life, can distinguish them with great ease at any time after the first molt, and can even distinguish the cast off skins.

Further, *Atlanis* invariably has a pale face—yellow or greenish, speckled with gray-brown; and just as invariably, the outside of the hind thighs, more mottled, with pale oblique streaks through the black.

*Femur-rubrum* has a pale face but less speckled, with no pale streaks through black of hind thighs, and with the upper white mark running from the side of the prothorax much the most conspicuous on the head behind the eyes.

#### A GREEN VARIETY OF THE ROCKY MOUNTAIN LOCUST.

In this connection I will also record the occurrence of a variety of *spretus*, in which all the pale or normally yellow-

ish-gray parts are bright green. These green individuals are conspicuous among their brown brethren. In the Mississippi Valley they generally constitute about one in a thousand of the progeny of invading swarms; but I have not noticed them among the fresh arrivals from the mountains. The green endures from the larva to the perfect state, and I have designated this variety as *viridis*. It is but a marked colorational variety, in a species which has not heretofore been known to present these colorational differences, and no one having a true conception of the differences of the three species just defined would think of placing this latter on the same grade.

THE SPECIES IS PURELY AMERICAN.

As the idea prevails among many of our farmers that our Rocky Mountain Locust is identical with the devastating species of the Old World, and Mr. Z. S. Ragan, in an otherwise excellent essay, read at the annual meeting of the Missouri State Horticultural Society for 1875, gives it as his opinion that our locusts "came over from Asia via Behring's Strait, to British America, and thence extended from time to time over Washington Territory, Oregon, California, Utah, Idaho, Montana, Wyoming, Dakota, Nevada, Colorado, Arizona, New Mexico, Texas, Kansas, Indian Territory, Nebraska, part of Missouri, Iowa, Minnesota and Wisconsin;" it may be well to insist here that there is no foundation whatever for such an opinion, and that *spretus* is a purely American species, occurring in no part of Europe or Asia.

## CHAPTER II.

### CHRONOLOGICAL HISTORY.

#### THE LOCUST PLAGUE IN THE "OLD WORLD."

THE plague of locusts is as old, nay older, than the Bible, where, in Exodus, we are told how they went up over the land of Egypt and "covered the face of the whole earth, so that the land was darkened; and they did eat every herb of the land, and all the fruit of the trees which the hail had left; and there remained not any green thing in the trees, or in the herbs of the field, throughout all the land of Egypt."\* Paulus Orosius tells us that in the year of the world 3800, such infinite myriads of locusts were blown from the coast of Africa into the sea and drowned,

[Fig. 5.]

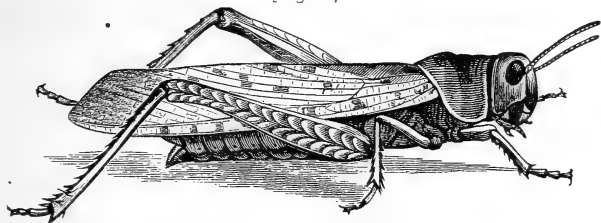

MIGRATORY LOCUST OF EUROPE.

that, being cast upon the shore, they emitted a stench greater than could have been produced by the carcasses of one hundred thousand men, and caused a general pesti-

---

\* Exodus, X, 15.

lence.\* Numerous, indeed, are the accounts of general devastation, pestilence and famine that have frequently followed in the wake of these locusts in the East, and travelers in South Africa, Asia and South Europe, have left us abundant records of the fearful devastations of this "Army of the Great God," as the Arabs term these migrating hosts. Their history is one of dire calamity and desolation; and their devastations have become part of the history of nations: they have even been perpetuated in coins. Those who have the curiosity to acquaint themselves with the history of locusts in the more ancient parts of the world, can not do better than refer to Kirby and Spence,† or to the compilation published in this country by Frank Cowan.‡ It suffices here to state that the injuries by locusts in the desert countries bordering mountain ranges in the East, are by no means matters of past history only, but that they are felt occasionally at the present time as they have been for all time past. In 1866, during the same year as our previous great invasion, Algeria and the whole country in the north of Africa, was severely visited, causing the famine of 1867, and the epidemics which followed. In 1874, these insects caused serious alarm in the same parts of Africa; and M. H. Brocard tells us that in the three subdivisions of Constantine, Setiff and Batna, 4,820 hectolitres (about 14,000 bushels) of eggs were collected.§ Every year since, they have done serious injury in parts of Europe, and this very year (1877) reports of fearful destruction come from Tripoli and Barbary. The species most conspicuous in its devastations, especially in Central Europe, is the Migratory

---

\* Oros, *Contra Pag.* 1, V, c. 2.

† Introduction to Ent. I, Letter VII, London, 1828.

‡ Curious History of Insects, pp. 101—131, Phila., 1875.

§ *Comptes Rendus*, Paris Academy, Jan. 25, 1875.

Locust (*Ædipoda migratoria*, Linn), though in Africa and Asia the *Acridium perigrinum* and the *Caloptenus Italicus* have similar destructive and migratory powers. All these insects belong to the same family as our own species, and the last named, even to the same genus.

## LOCUST RAVAGES IN AMERICA.

While the chronological record of locust invasions and devastations in the "Old World," is full and complete, the record of such invasions in our own country has never been fully written. The most complete record that I know of, is that by Alexander S. Taylor, of Monterey, Cal., published in the Smithsonian Report for 1858, (pp. 200—213), to which I am indebted for the earlier accounts, which follow. From what is here given, it is very evident that these insects have occasionally proved great plagues from the earliest settlement of the country; and there can be no doubt that from time immemorial, or since our continent assumed its present configuration, they have from time to time played the same rôle of devastators, and that the only exceptional circumstance about the 1874 and 1876 irruptions, compared with those of former years, is the larger area of settled and cultivated country devastated, and the consequent greater amount of distress entailed.

The earliest record I can find of locust injuries in America, is in Gage's West Indies, under date of the year 1632. In speaking of their visitation in Guatemala, he says :

"The first year of my abiding there it pleased God to send one of the plagues of Egypt to that country, which was of Locusts, which I had never seen till then. They were after the manner of our Grasshoppers, but somewhat bigger, which did fly about in numbers so thick and infinite that they did truly cover the face of the sun, and hinder the shining forth of the beams of that bright planet. Where they lighted, either upon trees or standing corn, there was nothing expected but ruin, destruction and barrenness ;

---

for the corn they devoured, the fruits of trees they ate and consumed, and hung so thick upon the branches that with their weight they tore them from the body. The highways were so covered with them that they startled the traveling mules with their fluttering about their heads and feet. My eyes were often struck with their wings as I rode along; and much ado I had to see my way, what with a montero wherewith I was fain to cover my face, what with the flight of them which were still before my eyes. Where they lighted in the mountains and highways, there they left behind them their young ones, which were found creeping upon the ground, ready to threaten such a second year's plague, if not prevented; wherefore all the towns were called, with spades, mattocks and shovels, to dig long trenches and therein to bury the young ones."

The early Jesuit missionaries of California have left numerous records of their injuries on the Pacific coast. Father Michael del Barco records their visitations in California in 1722, 1746, and the three succeeding years; also in 1753, 1754 and 1765. Clavigero, in his History of California, also gives a very full description of these pests.

In 1827, 1828 and 1834, they destroyed all the crops in the rancheros and missions, and in 1838 and 1846, again did great damage in Upper California. "For more than half a century they have troubled the Argentine Republic in South America. In a latitude corresponding with Louisiana and Texas, but in the southern hemisphere, they have made agriculture worthless, and rendered the settlement of that magnificent country between the Andes and the Atlantic Ocean, by a dense population, impossible."\* Dr. B. A. Gould gives a graphic account of a swarm of locusts in 1873 that devastated Cordoba, a swarm at least twenty miles in length and six miles in breadth, extending for an altitude of 5° like a thick, black trail of smoke.† Of the ravages of locusts in the Atlantic States, I shall speak more particularly in a future chapter. We have records of great injury from locusts in New Hampshire, Massa-

---

\* Rev. Edw. Fontaine, in *New Orleans Times*, March, 1866.

† *Amer. Journ. of Sc.*, Dec., 1873.

chusetts and Vermont, at several periods during the latter part of the last century.

HISTORY OF THE RAVAGES OF THE ROCKY MOUNTAIN  
LOCUST.

Coming now to the chronological history of the particular Rocky Mountain species in question, anything like substantial records fail us, and in order to give the following summary of its devastations during the present century, I have had to ransack the files of hundreds of periodicals, and to depend on a number of fugitive articles published during the last twenty-five years.

In 1818 and 1819, according to Neill's History of Minnesota, vast hordes of locusts appeared in Minnesota, eating everything in their course; in some cases the ground being covered with them to the depth of three or four inches. In the same years they were extremely injurious in the Red River country in Manitoba. In 1820, or the succeeding year, we hear of their falling upon the western counties of Missouri, as described in the following items :

"We were informed by old residents of West Missouri and some of the Indians, that long ago, I think it was in 1820, there was just such a visitation of grasshoppers as is now afflicting us. They came in the autumn by millions, devouring every green thing, but too late to do much harm. They literally filled the earth with their eggs, and then died. The next spring they hatched out, but did but little harm, and when full-fledged left for parts unknown. Other districts of country have been visited by them, but so far as I could learn, they have done but little harm after the first year."—S. T. Kelsey, Ottawa, (now of Hutchinson,) Kansas, in *Prairie Farmer*, June 15, 1867, p. 395.

A Missouri paper publishes a statement by an old settler that great numbers of grasshoppers appeared in Sept. 1820, doing much damage. The next spring they hatched out, *destroying the cotton, flax, hemp, wheat and tobacco crops*; but the corn escaped uninjured. About the middle of June they all disappeared, flying off in a south-east direction.—*Western Rural*, 1867.

It is reasonable to suppose that these 1820 swarms also ravaged Kansas and the country to the northwest, very

much as they did in 1874 and 1876, though no records of the fact are to be found, for the simple reason that the western country was unsettled by farmers. We know that during the same and the previous year the crops were destroyed in many parts of Manitoba, and the migrations of 1819 and 1820 must have been very similar to those of 1873 and 1874.

In 1845, and again in 1849, we have accounts, from various sources, of their swarming in Texas. In 1855 there was another very general irruption all over the western part of the continent. Says Mr. Taylor, in the Smithsonian Report already alluded to: "Up to the 11th of October, 1855, and commencing about the middle of May, these insects extended themselves over a space of the earth's surface much greater than has ever before been noted. They covered the entire Territories of Washington and Oregon, and every valley of the State of California, ranging from the Pacific Ocean to the eastern base of the Sierra Nevada; the entire territories of Utah and New Mexico; the immense grassy prairies lying on the eastern slopes of the Rocky Mountains; the dry mountain valleys of the republic of Mexico, and the countries of Lower California and Central America; and also those portions of the State of Texas which resemble, in physical characteristics, Utah and California. The records prove that the locusts extended themselves, in one year, over a surface comprised within thirty-eight degrees of latitude, and, in the broadest part, eighteen degrees of longitude.

"On several days in June, July and August, of 1855, the grasshoppers (or *langostas* of the Spaniards) were seen in such incredible numbers in the valley of the Sacramento, in California; in the valley of Colima, Southwest Mexico; in the valley of the Great Salt Lake; in Western



Texas, and in certain valleys of Central America, that they filled the air like flakes of snow on a winter's day, and attacked everything green or succulent with a voracity and despatch destructive to the hopes of the agriculturalists."

They are described as reducing the Mormons of Salt Lake, during that year, to a simpler diet than that of John the Baptist, for the people had to fall back on the locusts without the honey; and they caused a good deal of suffering in the then Territories of Kansas, Nebraska and Minnesota. The summer of 1855, like that of 1874, was exceedingly dry—the driest, in fact, that had been known for ten years.

In 1856 they again made their appearance in parts of Utah, California and Texas, but in diminished numbers. In Minnesota, however,\* and in Western and North-western Iowa their ravages during this year seem to have been greater.

In 1857 we hear of them again in various parts of the Northwest† and around the Assiniboine settlement in Manitoba,‡ and they destroyed the entire crop of a region of country extending from the base of the third plateau to the Gulf of Mexico, 150 miles in length, and about 80 miles in breadth, including the entire valley of the Gaudaloupe, and much of the territory watered by the Colorado and San Antonio rivers. Throughout this whole area of 12,000 square miles every green thing cultivated by man was consumed, and how much further northwest the ravages extended is not known.§ They reached as far east as Central Iowa.||

---

\* Rep. of Dept. of Agr., 1863, p. 36.

† Walsh's Ill. Ent. Rep., pp. 92-3; *Prairie Farmer*, April 25, 1868.

‡ *Canada Farmer*, Aug. 15, 1874.

§ Rev. E. Fontaine, *loc. cit.*

|| *Prairie Farmer*, April 25, 1868.

It is probable that part of the injury reported in 1856 and 1857 east of the Rocky Mountains was caused by the progeny from the immense swarms that swept over the country in 1855; and it is quite likely that some of them reached Missouri, for Mr. H. B. Palmer, of Hartville, has related to me that, about 1857, these insects passed through a portion of Wright county, from north to south, stripping everything on their way.

In 1860, as several Kansans have informed me, these locusts came and did much damage around Topeka, remaining a few days and leaving the last of August. This must have been a limited and rather local swarm.

In 1864 we again hear of locust invasions into Manitoba, Minnesota, and around Sioux City, Iowa, their eggs hatching and the young doing much damage the following year, 1865. In Colorado one of the most destructive visitations ever known there came in 1864 from the northwest, doing much damage, as did the progeny in 1865.

The year 1866 was another marked locust year, and the first, since that of 1855, in which the damage was sufficiently great and wide-spread as to attract national attention. The insects swarmed over the Northwest and did great damage in Kansas, Nebraska, and Northeastern Texas, and invaded the western counties of Missouri very much as they did in 1874. They came, however, about a month later than in that year. They were often so thick that trains were seriously delayed on account of the immense numbers crushed on the track. Mr. Walsh has published a full record of this invasion in the Report already cited.\*

In 1867 the progeny of those which fell upon the country the previous year did more or less damage, which was extensively reported during the early part of the growing

---

\* First Annual Rep. as Acting State Ent. of Ill., pp. 83-4 (1868).

season. The damage, however, was not general, and good crops were harvested in most of the country invaded the year before. But later in the season fresh swarms came from the Rocky Mountain region, and fell upon the fertile plains of the Mississippi Valley. Thus there were two fresh invasions, the one following the other, in the years 1866 and 1867; an occurrence which is quite exceptional, and to which the immense damage done during the latter year is, in great part, attributable. Mr. Walsh (*loc. cit.*) has given us, at great pains, a pretty full record of the doings of locusts in 1867, and from said record he makes it quite clear that the invasion of 1866 was followed in 1867 by a fresh, though less extensive one, direct from the Rocky Mountain region. I may add that a number of scraps and records of the insect's doings during those two years, other than those he has brought together, bear out his deductions. The locusts also fell upon Utah in immense swarms in 1867.

During the subsequent years of 1868 and 1869 we hear more or less of the remnants of these two vast swarms from the mountain region, and of their injury in the Mississippi Valley; but their numbers are always diminishing and their enemies increasing, so that during the latter year not a healthy individual was to be found, and in 1870 the race had nearly vanished from the invaded country—at least from its eastern portions. In 1868, they were particularly disastrous in Utah and the Red River Settlement of British America.

In 1869 there were still some remnants left of the 1867 invasion. From Leavenworth, Kansas, I received some, sent in a tin box, and in reaching me there was but one left, which, having eaten the others, was master of the situation. They hatched out in countless numbers from the 20th to 24th of March, in Holt county, Mo., and

were destructive east of Nemaha county, Kansas; but the injury that year was trifling, and the records show that the insects became more and more impotent.

During this year, 1869, and the two following years, as will be seen from what is said in Chapter IX, many of the common locusts of the country were unusually numerous and destructive; and the reports of their injuries must not be confounded with those of the Rocky Mountain species. Mr. Cyrus Thomas (*Am. Ent.* II, p. 82,) reports finding this species, in June, 1869, around St. Joseph, Mo. He says: "We arrived very early in the morning, and then they appeared to be somewhat torpid; yet when those in the grass were disturbed by the hogs, which were feeding upon them, they hopped about quite briskly. Swarms of them, as I was informed, had been flying over that section for a week previous to our arrival."

In 1870, what was probably this last species, swept down upon the country around Algona, Iowa, and in 1871 the progeny "hatched by myriads till after the first of June," and left about the first of July.\* During this year their injuries were also reported in parts of Utah and Colorado.

In 1872 again they did some harm in parts of Kansas, for Mr. Albert Cooper, of Beloit, Kan., wrote me (Sept. 1, 1872): "They came down upon us a few days ago, and are now eating up everything green." Mr. J. D. Putnam, who spent the summer of 1872 in the Rocky Mountains, also wrote me "that *spretus* was quite numerous in the valley of the Troublesome River."

#### THE INVASION OF 1873.

During the years 1873 and 1874, we had a repetition, in a great measure, of the years 1866 and 1867. The invasion

---

\* *Western Rural*, Chicago, September 26, 1874.

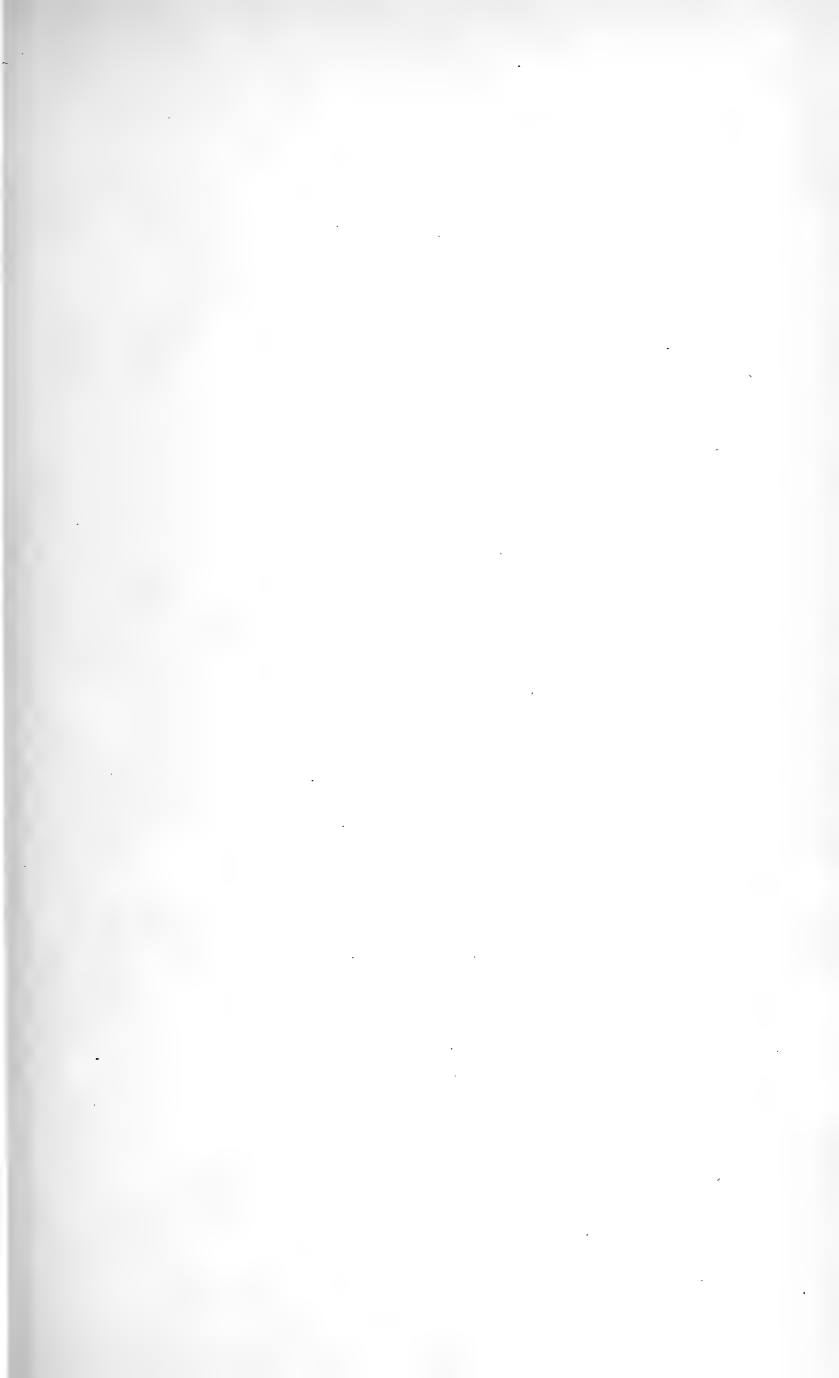
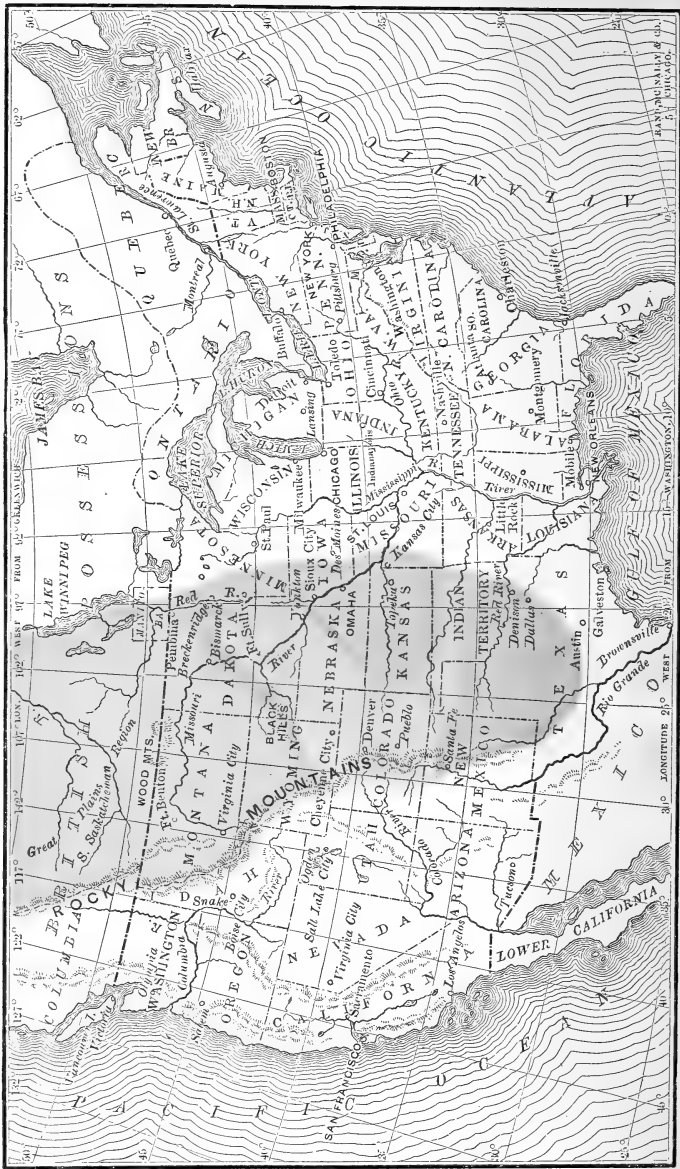

PLATE II.



Map of North America, illustrating the country east of the Rocky Mountains, overrun in 1874 by the Rocky Mountain Locust.

Prepared by C. V. Riley.

EXPLANATION TO PLATE II.

---

Country overrun in 1874.

Country invaded in 1874, but which suffered less on account of being sparsely settled.

Country ravaged in 1874, and which suffered most.

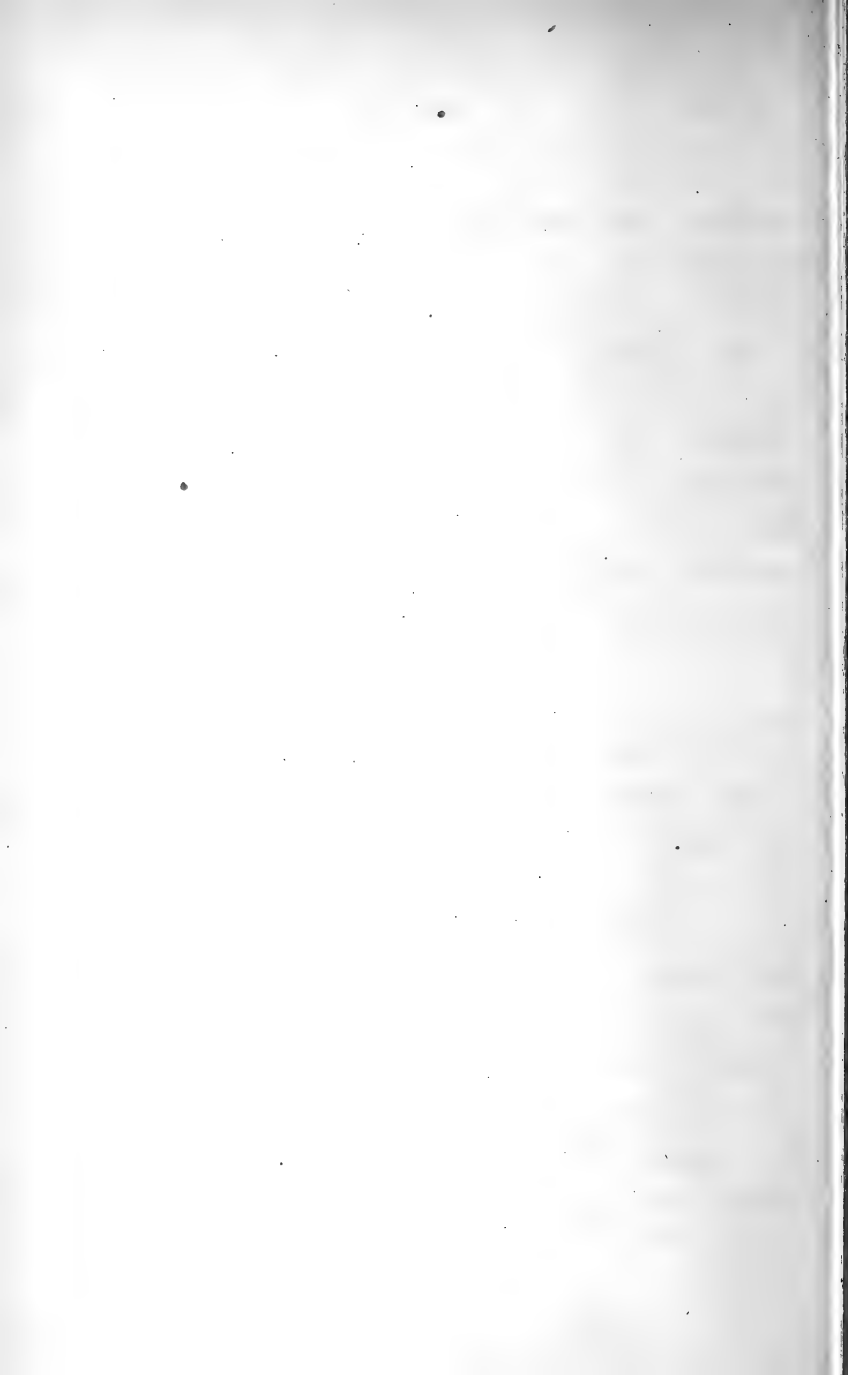



of 1873 was pretty general over a strip of country running from the northern parts of Colorado and southern parts of Wyoming, through Nebraska and Dakota, to the southwestern counties of Minnesota, and northwestern counties of Iowa—the injury being most felt in the last two more thickly settled States. The insects poured in upon this country during the summer and laid their eggs in all the more eastern portions reached. The cry of distress that went up from the afflicted people of Minnesota in the fall of that year is still fresh in mind, and the pioneers of Western Iowa, in addition to the locust devastations, suffered severe damage from a terrific tornado. During the same year great ravages were also committed by locusts in Southern California.

#### THE INVASION OF 1874.

We now come to the locust visitation of 1874, which will long be remembered as more disastrous, and as causing more distress and destitution than any of its predecessors. The calamity was national in its character, and the suffering in the ravaged districts would have been great, and famine and death the consequence, had it not been for the sympathy of the whole country and the energetic measures taken to relieve the afflicted people—a sympathy begetting a generosity which proved equal to the occasion, as it did in the case of the great Chicago fire, and which will ever redound to the glory of our free Republic, and of our Union.

From a very large number of data, culled from every available source, the accompanying map (Plate II) has been prepared, which will at a glance illustrate the country liable to be overrun by this Rocky Mountain scourge, and more especially the territory in the United States east of the mountains, visited in 1874. This last will be seen to em-

brace the entire States of Colorado, Nebraska and Kansas, and portions of Wyoming, Dakota, Minnesota, Iowa, Missouri, New Mexico, Indian Territory and Texas. The green color indicates the area over which the greatest injury was done ; the pink, the area which suffered less, because more sparsely inhabited ; and the salmon, the area which was more or less overrun by them. The map also shows the eastern limit reached by the locusts. The insects were doubtless equally numerous in the northwestern parts of Wyoming and Dakota, and in Montana, for, in fact, they breed there ; but the country is for the most part so barren and so thinly settled that the reports were very meagre. The loss to the States mentioned did not fall far short of fifty millions of dollars. That much of the damage resulted from the progeny of the swarms of 1873, which, hatching in the country already indicated, as invaded during that year, ravaged the crops of the country where they hatched, and eventually spread to the south-east, the records abundantly prove ; but there was likewise a fresh invasion direct from the mountain region, which added to that of 1873, rendered the year 1874 so memorable.

On account of the long continued drouth, and the ravages of the chinch bug, but little green food was left in Missouri and Kansas for the locusts to destroy. This, however, they took. In most of the invaded counties of Missouri, corn was already too hard to be damaged ; but the locusts stripped every green blade, and even the husks, when not already killed by the chinch bug.

The general direction from which they came was from the northwest, the reports showing remarkable agreement in this respect. The insects came nearly a month earlier than they did in 1866. Kansas suffered, perhaps, most severely.

Detailed accounts of this invasion, and of the destitution and suffering which resulted therefrom in the different States, will be found in the author's Seventh Annual Report on the Insects of Missouri. In that Report, in endeavoring to forecast the probable injury the following spring, in Missouri and adjoining country, I wrote as follows :

Setting aside possible but not probable injury from a new invasion, we may consider the probable injury that will result in 1875, from the progeny of those which came in 1874. The eggs which are deposited on southerly hill-sides often hatch before cold weather sets in, if the fall be warm and protracted, while many hatch soon after the frost is out of the ground in the spring. Yet the great bulk of them will not hatch till into April. That most of the eggs will hatch may be taken for granted unless we have very abnormal climatic conditions, and unprecedentedly wet and cold weather following a mild and thawing spell. The young issuing from these eggs will, also, in all probability, do much damage, as they did in the spring and summer of 1867. But the actual damage can not be foretold, as so much depends on circumstances. In 1867, in many counties of Kansas and Missouri, where the ground had been filled with eggs the previous fall, little harm was done in the spring—so small a percentage of the eggs came to anything and so unmercifully were the young destroyed by natural enemies. A severe frost kills the young after they have hatched, where a moderate frost does not affect them. \* \* \* Following a rather mild February the March of '67 was a very severe one, the thermometer frequently indicating 18 degrees below zero, and according to Mr. W. F. Goble, of Pleasant Ridge, Kansas, who wrote an excellent account of the insect, this severe weather caused many of the eggs to perish ; and he expresses the opinion that "judging from the voraciousness of those that did appear, I doubt not Kansas would have been made a perfect desert if all had lived."

If after the young hoppers hatch we have much cold wet weather, great numbers of them will congregate in sheltered places and perish before doing serious harm ; but if, on the contrary, our spring and early summer prove dry and hot (which is hardly to be expected after the several dry seasons lately experienced) much damage will result from these young locusts, where no effort is made to prevent it. They will ruin most garden truck, do much injury to grain, and affect plants very much in the order previously indicated under the head of "Food-plants." They will become more and more injurious as they get older, until, in about two months from the time of hatching, or about the middle of June, they will begin to acquire wings, become restless, and in all probability leave the locality where they were born, either wending their way further south or returning in the direction whence their

parents came the previous year. Some beevies may even pass to the eastward of the limit line reached in 1874, and fall upon some of the counties bordering that line ; but they will lay no eggs, and will, in time, run their course and perish from debility, disease and parasites.

The verification of the above predictions the following spring, was another proof of the soundness of the principal theories advanced in this work ; for while the injury proved greater in many sections than was anticipated, yet the occurrences, in the main, were accurately foreshadowed.

#### GENERAL OUTLOOK IN THE SPRING OF 1875.

The spring of 1875 brought the farmers of the locust region to a crisis somewhat unusual and peculiar. Two previous years of drouth and chinch bugs, followed by the locust incursion of the previous fall, had armed the people with unusual energy, born of hope and necessity, and there was everywhere determination to put forth the very best efforts. The opening of the spring favored the execution of this purpose. Timely rains and bright weather crowned the seeding time with unusual hope, and a much larger acreage of all spring crops was planted. The experience of previous locust years had been generally forgotten, and no effort to destroy the eggs had been made. The same genial sun that made wheat, oats, corn and flax grow apace, brought into activity myriads of the dreaded destroyers. Scarcely had the farmer begun to rejoice over a prospect of uncommon promise, when he saw his fields invaded by an enemy that overcame his utmost resistance. The severely stricken region, covering an area variously estimated at from 200 to 270 miles from east to west, and from 250 to 350 miles from north to south, and embracing portions of Nebraska, Kansas and Missouri, presented a variety of experience, some portions being comparatively exempt from injury, while others wore an aspect of devas-

tation that changed the verdure of spring into the barrenness of winter.

The tract in which the injury done by the destructive enemy was worst, was confined to the two western tiers of counties in Missouri, and the four tiers of counties in Kansas, bounded by the Missouri river on the east. The greatest damage extended over a strip 25 miles each side of the Missouri river, from Omaha to Kansas City, and then extending south to the southwestern limit of Missouri. About three-quarters of a million of people were to a greater or less extent made sufferers. The experience of different localities was not equal or uniform. Contiguous farms sometimes presented the contrast of abundance and utter want, according to the caprices of the invaders, or according as they hatched in localities favorable to the laying of the eggs. This fact gave rise to contradictory reports, each particular locality generalizing from its own experience. The fact is, however, that over the region described there was a very general devastation, involving the destruction of three-fourths of all field and garden crops.

While the injury was greatest in the area defined above, the insects hatched in more or less injurious numbers from Texas to British America—the prevalence of the insects in Manitoba being such that in many parts little or no cultivation was attempted.

For the relief of the sufferers there came the frequent and growing rains, carrying spring far into the usually drougthy summer, and giving the subsequent planting an admirable start. Then when the pests had increased to their highest number, and were working the most extensive ruin, the flood gates of the clouds were opened, and for thirty-six hours an unceasing torrent swept large numbers of them into the streams, until the surface of most

running water was black with locusts. For the destitution of Kansas an extra session of the Legislature provided partial relief. In both Kansas and Missouri, wherever the scourge extended, seeds were to some extent distributed by the Department of Agriculture, and by enterprising seedsmen, and committees were sent to more favored regions to obtain contributions of money, provisions and seed.

Early in May the reports from the districts most severely visited were very conflicting : the insects were confined within short radii of their hatching grounds. The season was propitious, and where the insects did not occur, everything promised well. As the month drew more and more to a close, the insects extended the area of destruction, and the alarm became general. By the end of the month the non-timbered portions of the country most affected were as bare as in winter. Here and there patches of *Amarantus Blitum* and a few jagged stalks of Milkweed (*Asclepias*) served to relieve the monotony. An occasional oat field, or low piece of prairie would also remain green ; but with these exceptions one might travel for days by buggy and find everything eaten off, even to the underbrush in the woods. The suffering was great and the people were well-nigh disheartened. Cattle and stock of all kinds, except hogs and poultry, were driven away to more favored counties, and relief committees were organized. Many families left the country under the influence of the temporary panic and the unnecessary forebodings and exaggerated statements of pessimists. Chronic loafers and idlers even made some trouble and threatened to seize the goods and property of the well-to-do. Relief work was, however, carried on energetically, and with few exceptions no violence occurred. Early in June the insects began to leave ; the farmers began replanting with a will.

As the month advanced, the prospects brightened, and by the Fourth of July the whole country again presented a green and thrifty appearance.

The immediate damage was the loss of labor expended in planting, and the seeding for about two-thirds of the crop acreage of the country, to which may be added the destruction of the fruit and the tame grasses. Detailed returns of the damage done in Missouri, showed a loss of over fifteen millions of dollars. The amount of loss redeemed by crops that succeeded after the insects left, it was impossible to determine ; but the amount was offset by the injury both temporary and permanent, to fruit, fruit trees, vineyards, gardens, meadows and pastures ; by the fact that such crops as flax, castor-beans, etc., were not estimated in the calculation ; and lastly, by the injury to stock, as the animals were necessarily driven out of the country, and by the general depreciation of property.

Missouri had never before been visited by a calamity so appalling, and so disastrous in its results, as the locust ravages of 1875. Other years have brought drought, chinch bugs, and partial or total failure of particular crops, but no event ever before so completely prostrated the country within which the ravages occurred. The suddenness and desolating power with which the attack came, where often the possessor of promising crops deemed them safe, acted as a paralysis upon those very faculties that are engaged in the forethought and deliberation necessary to self-preservation or concerted action. The farmer saw his green acres smiling with glorious hope to-day, and to-morrow, perhaps, all barren and bleak as in winter. It is no wonder that many communities were panic-stricken. Previous disaster had already brought many sections to a critical and suffering point, so that even during the winter the Legislature was appealed to for aid. Stock had been

dying ; feed of all kinds was scarce, and whole communities were relying on the promise of the spring. For this reason the locust ravages were all the more desolating and discouraging.

Some cases of actual starvation were reported in the papers, but I was unable to learn of a single instance which could be authenticated by the names of the suffering parties. Replies to the question, "Did any cases of actual destitution or starvation positively occur in your county?" from over a hundred correspondents in the counties in Missouri which suffered most, with scarcely an exception were to the effect that while there was great destitution no cases of starvation occurred.

The great exodus of the flying swarms from our borders began early in June, and reached its acme about the middle of the month. Some were leaving up to the last week in the month. The cheering news "they fly, they fly," was wired over the country from Coffeyville, Kansas, on the 29th of May, and a few days later these same words that cheered the waning spirit of General Wolfe as he saw that victory remained with England, and Canada was lost to France, passed along the lines from our western counties, and gladdened the hearts and revived the dying hopes of the suffering farmers.

I had such confidence in the correctness of the theories which I have advanced, that, in addressing the farmers of Missouri, during the spring when they were most disheartened, and while the consternation was greatest, I did not hesitate to assure them that their troubles were temporary; that the insects would leave in time to permit the growth of good crops of most of the products of the soil. Obligated to sail for Europe in June, I told them that I should return in the fall to find them jubilant where then they were discouraged. I came back in September. The desolation of



June had been followed by a luxuriance of vegetation without parallel. The change wrought in three months was magical ; and as I addressed them again in the midst of plenty, the farmers felt thankful for the confidence and encouragement they had received in such different circumstances, three months before.

DESTINATION OF THE DEPARTING SWARMS OF 1875.

That the insects which left the Mississippi Valley in 1875 reached into British America there is abundant proof. The *Winnipeg Standard* of August 19, 1876, as quoted by Professor Whitman, says :

The locusts which hatched in Missouri, Kansas and Nebraska [in 1875], in an area of 250 miles from east to west, and 300 miles from north to south, took flight in June, and invariably went north-west, and fell in innumerable swarms upon the regions of British America, adjoining Forts Pelly, Carlton and Ellice, covering an area as large as that they vacated on the Missouri River. They were reinforced by the retiring column from Manitoba, and it seemed to be hoping against hope that the new swarms of 1876 would not again descend upon the settlements in the Red River Valley. Intelligence was received here that the insects took flight from the vicinity of Fort Pelly on the 10th of July, and then followed a fortnight of intense suspense.

Professor G. M. Dawson, of Montreal, wrote me : " You may be interested in knowing that the northward flying swarms in 1875 penetrated a considerable distance into the region west of Manitoba, while most of the insects hatching in the latter province went southeastward when winged, and that large numbers got at least as far east as the Lake of the Woods." In an interesting paper in the *Canadian Naturalist*, on the " Appearance and Migrations of the Locusts in Manitoba and the N. W. Territories in the Summer of 1875," Professor Dawson further gives many other valuable records, some of which, as bearing on the question under consideration, I quote entire, as they will hardly bear condensing.

From the reports now received from Manitoba and various portions of the Northwest Territory, and published in abstract with these notes, it would appear that during the summer of 1875 two distinct elements were concerned in the locust manifestation. First, the insects hatching in the province of Manitoba and surrounding regions, from eggs left by the western and northwestern invading swarms of the previous autumn; second, a distinct foreign host, moving, for the most part, from south to north. The locusts are known to have hatched in great numbers over almost the entire area of Manitoba, and westward at least as far as Fort Ellice on the Assiniboine river (long.  $101^{\circ} 20'$ ), and may probably have been produced, at least sporadically, in other portions of the central regions of the plains; though in the summer of 1874, this district was nearly emptied to recruit the swarms devastating Manitoba and the Western States, and there appears to have been little if any influx to supply their place. Still further west, on the plains along the base of the Rocky Mountains, from the 49th parallel to the Red Deer river, locusts are known to have hatched in considerable numbers—but of these more anon.

Hatching began in Manitoba and adjacent regions in favorable localities as early as May 7th, but does not seem to have become general till about the 15th of the month, and to have continued during the latter part of May and till the 15th of June. \* \* \*

The destruction of crops by the growing insects, in all the settled regions was very great, and in many districts well nigh complete. The exodus of these broods began in the early part of July, but appears to have been most general during the middle and latter part of that month, and first of August. The direction taken on departure was, with very little exception, southeast or south. It is to be remarked, that as there does not seem to have been during this period any remarkable persistency of northwest or westerly winds, the insects must have selected those favoring their intended direction of migration, an instinct which has very generally been observed elsewhere.

\* \* \* \* \*

Foreign swarms from the south crossed the 49th parallel with a wide front stretching from the 98th to the 108th meridian, and are quite distinguishable from those produced in the country, from the fact that many of them arrived before the latter were mature. These flights constituted the extreme northern part of the army returning northward and northwestward from the States ravaged in the autumn of 1874. They appeared at Fort Ellice on the 13th of June, and at Qu'Appelle Fort on the 17th of the same month, favored much no doubt by the steady south and southeast winds, which, according to the meteorological register at Winnipeg, prevailed on the 13th of June and for about a week thereafter. After their first appearance, however, their subsequent progress seems to have been comparatively slow, and their advancing border very irregular in outline. They are said to have reached Swan Lake House—the most northern point to which they are known to have attained—about July 10th; while Fort Pelly, further west, and

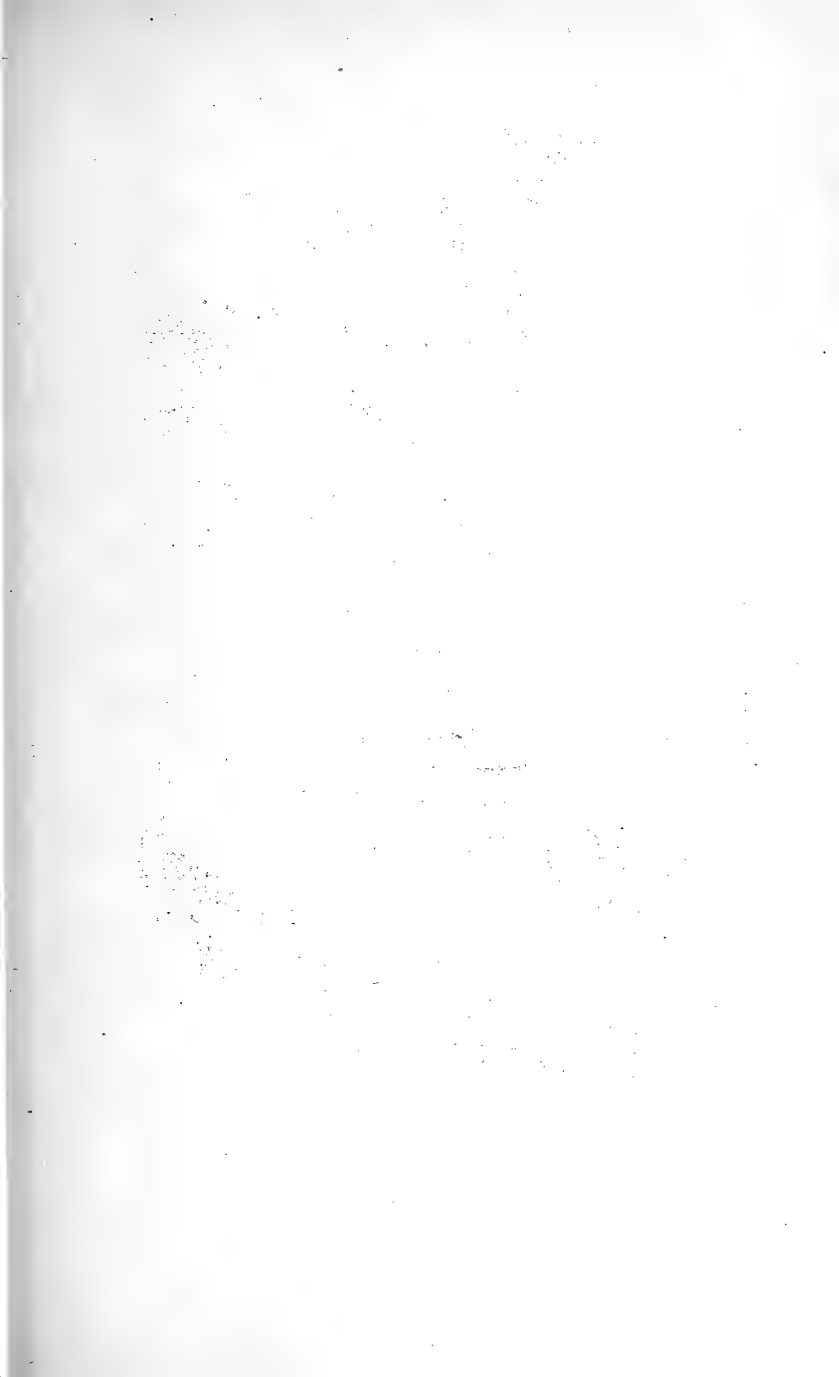
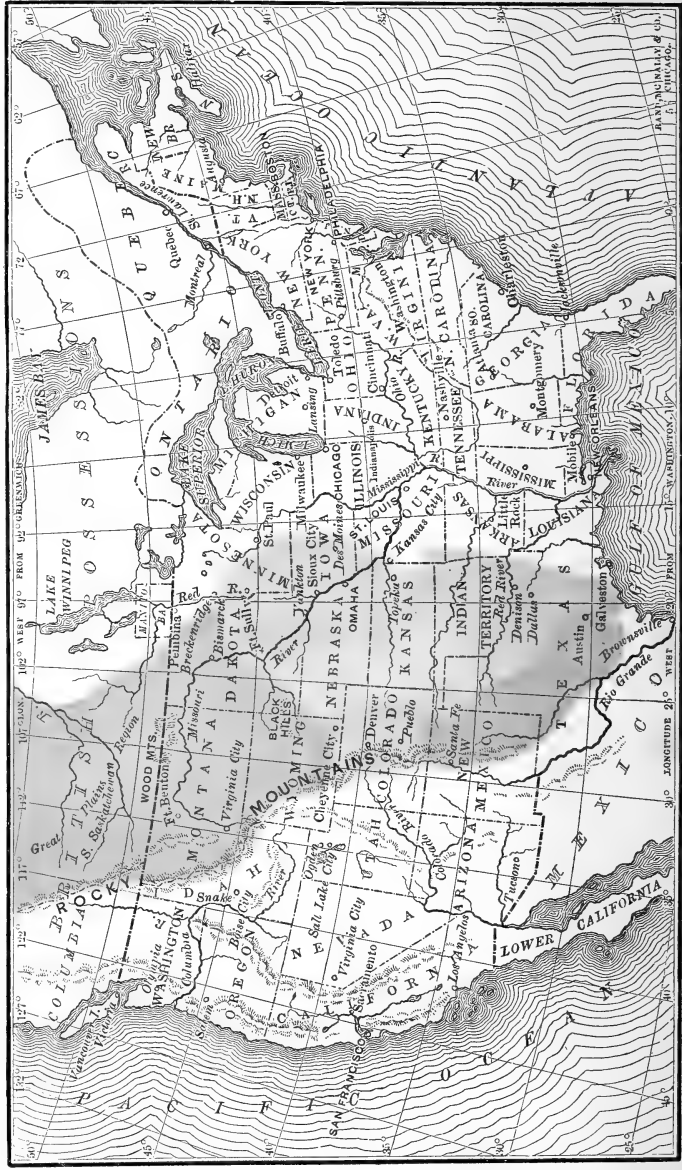

PLATE III.



Map of North America, illustrating the country east of the Rocky Mountains, overrun by the Rocky Mountain Locust in 1876. Prepared by C. V. Riley.

EXPLANATION TO PLATE III.

---

Country overrun in 1876.

Country in which eggs were laid sparsely in 1876.

Country in which eggs were laid thickly. Most threatened in 1877.



nearly a degree further south, was reached July 20th, and about seven days were occupied in the journey from there to Swan River Barracks, a distance of only ten miles.

It is thus obvious not only that vast swarms reached into British America in 1875, from our own country, but that the young hatched there from swarms that had come the previous year from the farther Northwest.

There was, therefore, north of the 49th parallel, a repetition of the devastation we were at the time experiencing in the States; the insects hatching there in bulk just about the time they were leaving Texas on the wing. In these facts we get an explanation of

#### THE INVASION OF 1876.

In opposition to contrary opinion widely circulated, I expressed my belief, a year ago, that in Missouri, Kansas and Nebraska, first, there would not hatch as many locusts in the spring as would naturally hatch in ordinary seasons from indigenous species; second, that, compared with other parts of the country, those States most ravaged by locusts in the spring and early summer of 1875 would enjoy the greater immunity, during the same season of 1876, not only from locust injuries, but from the injuries of most other noxious insects; that, in short, the people of the ravaged section had reason to be hopeful rather than gloomy; that they certainly would not suffer in any general way from locust injuries in the early season; and that the only way in which they could suffer from the migrating pest was by fresh swarms, later in the year, from the far Northwest.—*Mo. Ent. Rep.* 8, 155-6.

Like the other opinions as to the future doings of this insect that I had felt warranted in expressing in an unqualified way, this last was fully justified by subsequent events.

From most of the so-called Western States the crop returns were favorable, though the harvest was in many sections impeded, as it was in 1875, by too much wet weather. In no part of the country was the outlook more flattering than in Western Missouri, Kansas, Nebraska, Iowa, and the country so seriously ravaged by locusts the previous year, and the farmers throughout that section of country had seldom been freer from insect ravages, or

more hopeful. The freedom from other noxious insects was everywhere apparent. In parts of the Northwest, as in the East, the conditions were very different from what they were in the Mississippi Valley, and the crops suffered more or less from excessive drouth. In Colorado there was some alarm, as the insects hatched in many localities, but by no means so generally as in the previous years. By persevering effort the farmers generally got the mastery over them and made good crops. In Minnesota, again, in some of the southern counties, where eggs were laid, considerable damage was done, though not nearly so much as in 1875. During the second week of July the locusts took wing from that region, and it is interesting to note that they instinctively took a north and northwest course, just as in the previous year the fledged insects had done a few weeks earlier in the season from Missouri and the adjacent country to the west. Numerous dispatches to St. Paul, Minneapolis, and other papers, show conclusively that the general direction taken was northwest, and that when the wind was unfavorable the insects awaited a change.

Such was the condition of things up to the early part of August, and I began to hope that the country that had suffered so much of late years by locust devastations, was at last free from the scourge, and would not be overrun again for some years to come. But the great drouth which prevailed in the Northwest appears to have favored the hatching and development of the insects in that section; and no sooner had our people begun to congratulate themselves on the departure of the pests, than reports came of the movement of new swarms from the north and northwest. From that time on, till the approach of winter, their movements were constantly reported and they eventually overswept a large part of the Western country.



A detailed record of this invasion published in the 9th Mo. Entomological Report, makes it manifest that the locusts that hatched and did more or less damage in Minnesota early in the year, endeavored to get away to the northwest as soon as they acquired wings. They were subsequently repulsed and borne back again by the winds to their hatching places; thence south and southwest into Iowa and Nebraska. As they rise and fly from day to day they concentrate and condense, since in passing over a given area during the hotter parts of the day new accessions are constantly being made to the flying hosts which, with serried ranks, descend in the afternoon. Thus, in returning, the swarms were thicker and more destructive in places than they were in leaving. Yet the column which thus came back to Minnesota and passed to the south and southwest was more straggling than in 1874, and by the middle of the month it had spent its force and left eggs throughout most of the country traversed. Had the invasion consisted of these alone, the damage would have been but slight, and the insects would hardly have reached into Kansas. Their eggs, laid in August, were far more liable to injury and to premature hatching than those laid later. But fresh swarms that hatched in Dakota, and farther northwest, followed on the heels of the Minnesota swarms, passing over much of the same country to the east and southward into Colorado, and eventually overrunning the larger part of Nebraska and Kansas, the western half of Iowa and some of the western counties in Missouri, and reaching into Indian Territory, Texas, and parts of Arkansas.

The extent of the region invaded will appear by referring to the map (Plate III). Coming generally later than in 1874, they did less damage, and the farmers were in so much better condition to withstand injury, that it was

much less felt. In most sections visited, part of the migrating hosts remained to lay eggs; and the invasion of 1876 is remarkable, as compared with that of 1874, for the large extent of country supplied with eggs. Another fact is noticeable, viz., that the very parts of Minnesota in which eggs were laid in 1875, and the portions of Missouri and Kansas in which they were most thickly laid in 1874, escaped in 1876. I can not believe, however, that this is anything more than coincidence.

A careful review of the invasion, shows that it was made up, 1st, of such insects as hatched out in Southwestern Minnesota, and parts of Colorado, Wyoming and Dakota; 2nd, of additions to these from Montana and British America. To what extent those in either of these categories were made up of the progeny from the insects that left our country in 1875 we shall never be able accurately to determine. The proportion of parasitized and diseased insects that left Missouri, doubtless became less among those which hatched and rose from the farther north and west, and we may, I think, take it for granted that the larger part of the swarms that reached Montana and British America, laid eggs. In addition to the vast swarms which invaded the Northwest from the south and southeast, there were in 1875, as Prof. Dawson shows, others that hatched in the Northwest, pouring from British America into our Northwest territory. There were, in fact, in Manitoba and large parts of the Northwest, two grand opposing movements of the winged insects, which thus to some extent replaced each other and coalesced about our northern boundary. Bearing this in mind, we can understand the increased area in the Northwest over which eggs were laid that year, and from which the 1876 swarms had their source. As no eggs were laid in Manitoba, while the young are known to have abounded in the mountain region

to the west of that province, it is more than probable that the principal source of the 1876 invasion was Montana and the Saskatchewan and Swan River countries. The question as to how far the Northwest breeding grounds are recruited, by the insects which hatch in the more fertile country which I have designated as outside the species' natural habitat, is a most interesting one; for if thus recruited, there is all the greater incentive for us to exterminate the young insects which hatch with us. All such questions can be settled, if at all, only by a thorough study of the subject by a properly constituted commission, such as that now charged with the work, under the Department of the Interior.

#### EASTERN LINE REACHED.

A study of the eastern limit of the invasion of 1876, compared with that of 1874, shows that it is peculiar in reaching farther east in Minnesota and Iowa, and farther south and east in Texas. The limit-line—extending from Clay county, Minnesota; bulging toward St. Paul, reaching southwardly to the center of Iowa; thence westwardly receding to Lawrence, Kansas, and bulging again to Southwest Missouri—is more irregular between the 36th and 46th parallels than it was in 1874. On an average, however, it does not extend east of the 94th meridian.

#### THE OMAHA CONFERENCE.

As an incident of the 1876 invasion, the Conference of the Executives of those States and Territories which most suffer from locust ravages, and of scientific gentlemen interested in the subject, held at Omaha, Neb., on the 25th and 26th of October, is worthy of mention. The following gentlemen, with the writer, were in attendance: Prof. Cyrus Thomas, of Illinois; Gov. Sam'l J. Kirkwood,

of Iowa ; Gov. Thomas A. Osborne, of Kansas ; Gov. Silas Garber, Ex-Gov. Robert W. Furnas, Prof. C. D. Wilber, Prof. A. D. Williams, and Hon. Geo. W. Frost, of Nebraska ; Gov. John S. Pillsbury, Pennock Pusey, and Prof. A. Whitman, of Minnesota ; Gov. John L. Pennington, of Dakota ; and Gov. C. H. Hardin, of Missouri.

The Conference was called at the invitation of Gov. Pillsbury, in the hope of obtaining concert of action in the best means of meeting or averting the evil. After a two-days' session, and an instructive interchange of experiences and opinions, and the passage of a series of resolutions, a committee consisting of John S. Pillsbury, Pennock Pusey, and myself, was appointed to prepare for publication the official report of Proceedings, together with a summary of the best means known for counteracting the evil ; and 10,000 copies of a pamphlet of 72 pages were accordingly published last fall. By being widely distributed, this pamphlet has undoubtedly done much good, and has also had no small share in bringing about certain much needed State and National legislation.

## CHAPTER III.

---

### NATIVE HOME AND GEOGRAPHICAL RANGE OF THE SPECIES EAST OF THE MOUNTAINS.

#### SOURCE OF THE DEVASTATING SWARMS THAT REACH INTO THE MISSISSIPPI VALLEY.

THERE is some difference of opinion as to the precise natural habitat and breeding place of the Rocky Mountain Locust, but the facts all indicate that it is by nature a denizen of high altitudes, breeding in the valleys, parks and plateaus of the Rocky Mountain region of Colorado, and especially of Montana, Wyoming and British America. Prof. Cyrus Thomas, who, through his connection with Hayden's geological survey of the Territories, has had an excellent opportunity of studying it, reports it as occurring from Texas to British America and from the Mississippi (more correctly speaking, the line I have indicated) westward to the Sierra Nevada range. But in all this vast extent of country, and especially in the more southern latitudes, there is every reason to believe that it breeds continually only on the higher mountain elevations, where the atmosphere is dry and attenuated, and the soil seldom gets soaked with moisture. Prof. Thomas found it most numerous in all stages of growth along the higher valleys and canyons of Colorado, tracing it up above the perennial snows, where the insect must have hatched, as it was found in the adolescent stage. In crossing the moun-

tains in Colorado it often gets chilled in passing the snows, and thus perishes in immense numbers. The bears of this locality desire no better condiment wherewith to season their usual repasts.

My own belief is that the insect is at home in the higher altitudes of Utah, Idaho, Colorado, Wyoming, Montana, Northwestern Dakota, and British America. It breeds in all this region, but particularly on the vast hot and dry plains and plateaus of the last named Territories and on the plains west of the mountains; its range on the east being bounded, perhaps, by that of the buffalo grass. Mr. Wm. N. Byers, of Denver, Colorado, shows that the insects hatch in immense quantities in the valleys of the three forks of the Missouri river and along the Yellowstone, and that, when fledged, they move on from there in a southeast direction at about the rate of 10 miles per day. The swarms of 1867 were traced, as he states, from their hatching grounds in West Dakota and Montana, along the east flank of the Rocky Mountains, into the valleys and plains of the Black Hills, and between them and the main Rocky Mountain range.\*

In all this immense stretch of country, as is well known, there are extensive tracts of barren, almost desert land, while other tracts for hundreds of miles bear only a scanty vegetation; the short buffalo grass of the more fertile prairies giving way, now to a more luxurious vegetation along the water courses, now to the sage bush and a few cacti. Another physical peculiarity is found in the fact that not only does the spring on these immense plains sometimes open as early, even away up into British America, as it does in Chicago, or exceptionally even in St. Louis, but the vegetation is often dried and actually burned out

---

\* See Hayden's Geol. and Geogr. Survey of the Territories, 1873, pp. 282-3.

in the early part of July, so that not a green thing is to be found. Our Rocky Mountain Locust, therefore, hatching out in untold myriads in the hot plains, five or six thousand feet above the sea level, will often perish in immense numbers if the scant vegetation of its native home dries up before it acquires wings; but if the season is propitious and the insect becomes fledged before its food supply is exhausted, the newly acquired wings prove its salvation. It may also become periodically so prodigiously multiplied in its native breeding places that, even in favorable seasons, everything green is devoured by the time it becomes winged.

In either case, prompted by that most exigent law of hunger—spurred on for very life—it rises in immense clouds in the air to seek for fresh pastures where it may stay its ravenous appetite. Borne along by the prevailing winds that sweep over these immense treeless plains from the northwest, often at the rate of fifty or sixty miles an hour, the darkening locust clouds are soon carried into the more moist and fertile country to the southeast, where with sharpened appetites, they fall upon the crops like a plague and a blight. Many of the more feeble or of the more recently fledged perish, no doubt, on the way; but the main army succeeds, with favorable wind, in bridging over the parched country which offers no nourishment. The hotter and drier the season, and the greater the extent of the drouth, the earlier will they be prompted to migrate, and the farther will they push on to the east and south.

My late friend, Benj. D. Walsh, was of the opinion that the swarms which pour down upon the Mississippi Valley come from the mountain regions of Colorado. My own belief, first announced in 1874, that they originate in the Northwest, has been very strongly confirmed by subsequent events; and however much some of the Western States

may suffer from swarms from the mountain regions farther south, it seems quite certain that the extensive and disastrous swarms which come late in summer and fall, and which reach as far east as Missouri, have their origin in the vast plains regions of the Northwest lying east of the mountains, in Montana, Dakota, and the Saskatchewan and Red River countries of British America.\* Some writers find it difficult to believe that the insect can fly over such immense distances, and they believe that the swarms originate (as Mr. S. H. Scudder, of Cambridge, puts it), "in the immediate vicinity of the regions which they devastate."

Such language is not very definite, since much of the country devastated must be in the immediate vicinity of the hot, dry plains and plateaus in which I believe the species is more particularly at home. The swarms that occasionally, during summer, devastate the country in which the species is not indigenous, must necessarily be the progeny of insects developed at no great distance from the sections they invade, whether they come from Minnesota southward, from Colorado eastward, or from Texas northward; and I endeavored to draw the distinction in 1874 between these summer swarms and the more disastrous fall swarms. On this point the Minnesota commission remarks (Special Rep. to Gov. Davis, p. 25) :

It is plain that locusts hatched in Colorado and regions to the south and southwest of Minnesota, acquire wings in time to allow them to reach this State in the former half of June. This is shown by the time when the invasion occurred in 1873, and by the immense flights of locusts which passed over Nebraska and Dakota to the northward in June, 1875. It seems to be a common impression that the locusts which have invaded Minnesota at other times were hatched in Montana, Northwestern Dakota and British America, and this is rendered probable by what few facts we know, and by

---

\* The origin of the swarms that devastate the Pacific slope is probably in the similar high plains regions of Washington, Idaho and Oregon.



the time and direction from which they came. These attacks are all represented as coming from the west, north or northwest, and reached the Red River Settlement in the last week of July, 1818, the Upper Mississippi about the same time in 1856, the western line of the State in the former half of July, 1864, and on July 15th, 1874. In the last three cases the invasions did not reach their farthest limit until a considerable portion of the crops had been harvested.

If Mr. Scudder means that the hordes that in August and September occasionally overrun the whole territory which I have indicated as outside the insect's natural habitat, originate within or upon the borders of that territory—the country south of the 44th parallel and east of the 100th meridian—then the facts are entirely against his supposition. The late swarms of 1874 and 1876, are known to have traveled from five hundred to six hundred miles after having reached the more thickly settled country. Late appearance and late egg-laying imply late hatching, which, in the main, must needs have taken place in northerly or sub-alpine regions. The invasion of the northern regions of Minnesota, Dakota, Montana and Manitoba, from the still farther northwest, also makes it clear that the insects come from beyond. The theory of short flights and development, in the immediate vicinity of the country devastated, will not answer for the late disastrous and general irruptions like those of 1866, 1874 and 1876 ; and in discussing this question the difference between these irruptions and the earlier, more frequent and less disastrous ones, should always be borne in mind.

The species, as defined in this work, and as it swoops down from the mountain region, does not, as some claim, occur every year in Missouri, Texas, Kansas, or any of the country to which I have indicated it is not indigenous. It occurs there only as the dwindling progeny of the swarms from the west or northwest, and never becomes acclimated. I have traveled through Iowa, and from

Omaha to Denver, collecting plants and capturing insects along the route on every occasion ; I have traveled extensively in Kansas, Indian Territory and Texas, always collecting ; I have been overwhelmed in the latter State with swarms of locusts while in front of an engine, and yet, among all the locusts collected, I have never found the genuine *spretus*, except as it came from the west or northwest, or hatched from eggs laid by those which had thence come. It can not be found there any more than it can be found in the western counties of Missouri, except as the progeny of invading swarms. There is no instance on record of the species, when hatching out in any of this country, remaining long enough to lay eggs, even supposing it capable of doing so in such circumstances. We find it multiplying continuously west and north of the boundary indicated ; pushing annually, in detachments, eastward from the mountains to the west, and southeastward from the country to the northwest ; but only at long intervals does it sweep down in countless myriads and in extended and devastating swarms from the extreme northwest. Just beyond the confines of the country in which it permanently multiplies, it follows that it will more often do injury than farther east and south ; it will also hold its own longer ; but sooner or later it vanishes from the country beyond those confines. It either vacates the territory on the wing, or is destroyed by influences adverse to its well-being.

In placing these confines along the 44th parallel and the 100th meridian, I think I have given the utmost southern and eastern limits. It is even doubtful whether the species permanently multiplies in much of the country for some degrees north and west of the territory thus indicated. Prof. Thomas indicates the eastern boundary as along the 103rd meridian, while Mr. G. M. Dawson, in the

pamphlet already referred to, says that "north of the 49th parallel, the whole area of the third or highest prairie-plateau, and probably much of the second, are congenial breeding places, and here the locusts are always in greater or less numbers." Regarding the western boundary, nothing struck Prof. Thomas\* as more singular than the few specimens of *spretus* collected west of the mountain range by the Hayden Geological Survey, from which he infers that the line of the survey was along the southwest border of its district. Mr. J. D. Putnam, of Davenport, Iowa, who spent July, August and September of 1875, in Utah, also informs me that he did not meet with a single specimen.

That the native home of the species is what naturalists understand as sub-alpine, is rendered pretty certain, also, by the fact of its abounding to such an extent in British America, and of its breeding in the higher mountain elevations, even up to the perennial snows. In fact, so high up does it breed that it often hatches so late in the season as to be overtaken by the cold of the succeeding winter before acquiring growth, when of course it perishes without begetting. The truly alpine country can not, therefore, be its native home; and those found breeding at such a height must be the progeny of others which flew from the plains, either east or west of the mountains. Physical barriers on the high mountain summits put a limit to the insect's extension and propagation, just as they do in the Mississippi Valley.

---

\* Preface to his Report upon the Collections of Orthoptera made in Nevada, Utah, California, Colorado, New Mexico, and Arizona, in 1871, 1872, 1873, and 1874, by Hayden's Geol. Surv. of the Terr. (1876).

---

IT CAN NOT PERMANENTLY THRIVE OR PERPETUATE ITSELF  
IN THE MISSISSIPPI VALLEY.

The comparatively sudden change from the attenuated and dry atmosphere of five to eight thousand feet or more above the sea level, to the more humid and dense atmosphere of one thousand feet above that level, does not agree with the species. The first generation hatched in this low country is more or less unhealthy, and those that attain maturity do not breed, but quit the country. At least such is the case in the whole of the Mississippi Valley proper. As we go west or northwest and approach nearer and nearer the insect's native home, the power to propagate itself and become localized, becomes, of course, greater and greater, until at last we reach the country where it is found perpetually. Thus in the western parts of Kansas and Nebraska, in parts of Colorado and Minnesota, in fact, in all the region indicated by the pink color in Plate I, the progeny from the mountain swarms may multiply to the second or even third generation, and wing their way in more local and feeble beavies to the country east and south. Yet eventually they vanish from that region and perish, unless fortunate enough to be carried back by favorable winds to the higher country where they flourish. There is nothing more certain than that the insect is not autochthonous in Texas, West Arkansas, Indian Territory, West Missouri, Kansas, Western Iowa, Nebraska, or even Minnesota; and whenever it overruns any of those States it sooner or later abandons them. The same also is true of parts of Colorado, Montana, Dakota, and even of Manitoba.

THE CONDITIONS WHICH PREVENT THE PERMANENT SETTLEMENT OF THE SPECIES IN THE MISSISSIPPI VALLEY.

The conditions which determine the geographical limits in which a species can exist, are often complex, and it is

not generally easy to say precisely what they are. Assuming that I have correctly placed the native home of the species in the higher, treeless and scarcely habitable plains of the Rocky Mountain region of the Northwest, and that it is sub-alpine, we may perhaps find, in addition to the comparatively sudden change from an attenuated and dry to a more dense and humid atmosphere, another tangible barrier to its permanent multiplication in the more fertile country to the southeast, in the lengthened summer season. As with annual plants, so with insects (like this locust) which produce but one generation annually and whose active existence is bounded by the spring and autumn frosts—the duration of active life is proportioned to the length of the growing season. Hatching late and developing quickly in its native haunts, our Rocky Mountain Locust when born within our borders (and the same will apply in degree to all the country where it is not autochthonous), is in the condition of an annual northern plant sown in more southern climes; and just as this attains precocious maturity and deteriorates for want of autumn's ripening influences, so our locust must in such circumstances deteriorate. If those which acquired wings in Missouri, Kansas, Iowa, etc., early in June of 1875, had staid long enough to lay eggs, supposing them capable of doing so, these eggs would inevitably have hatched prematurely, and the progeny must in consequence have perished. There would have been no time for a second generation to mature: such a second generation would have been cut off by winter's frosts without perpetuating.

Being a firm believer in change by modification in what we call species, and that climatic conditions play a most important part in causing this change, and that they act more rapidly with lower animals than most evolutionists grant, the idea has been very strong in my mind that the

species might become profoundly modified in the direction of *Atlantis* in the course of two or three generations in the country to the southeast, and that in this way and through miscegenation with our native species, its extinction from our territory might also be accounted for. The same possibility has also been suggested by Prof. Thomas—a professed anti-Darwinian—in an elaborate paper published in October, 1875, in the Chicago *Inter-Ocean*, and, as bearing on this point, I will state that the specimens which hatched in and left the western counties of Missouri in 1875, were, on an average, somewhat darker and smaller than their parents. But after fully digesting all the facts, I am convinced that these influences play a very unimportant part, if any; and that they can not be considered as factors in the problem. All that could get away from the regions of Texas, Missouri, Kansas, Iowa and Nebraska ravaged in 1875, did so; and if I may judge from experience in Missouri, those that could not, perished, so that in the fall not a remnant of the army was left.

But whatever the causes, the fact of debility, disease and deterioration in, as well as migration from, the more fertile southeastern country which the species occasionally devastates, stands forth clearly and can not be gainsaid. The following observations from careful observers may be placed on record here :

Mr. Riley is of the opinion that the grasshoppers run out in a few generations after they leave their native sandy and gravelly soil. My experiments so far as they go, verify that opinion. For several years I have caught grasshoppers during early summer that came fresh from the direction of the mountains, and by attaching their legs with fine silk threads to a small spring balance, found that their physical strength was from twenty-five to fifty per cent. greater than that of grasshoppers treated the same way that were hatched in Nebraska or in States further eastward or northward. The same result was reached by caging them, and ascertaining how long they would live without food, and also by vivisection. In some places, also, the eggs that were laid in different years since 1864 did

not hatch out. The changes from extreme wet to dry, and from cold to hot weather, or some other unknown causes, seem to sap their constitutional vigor. Were it not for this, long ere now these grasshoppers would, from their enormous numbers, have desolated the whole country as far east as the Atlantic.—[Prof. Sam'l Aughey, of the University of Nebraska, in the Lincoln (Neb.) *Journal*.

I have observed hundreds of winged locusts fall to the ground during flight, either already dead or soon dying. These upon examination have generally proved to contain no parasites, and I judge that their death was in consequence of impaired strength, this second generation raised in an unnatural climate not equaling in vitality the first generation, and succumbing to the fatigue consequent upon extended flight.—[Prof. F. H. Snow, of Kansas State University, in *Observer of Nature*.

IT WILL NEVER DO SERIOUS HARM EAST OF THE NINETY-FOURTH MERIDIAN.

A full month before a single specimen of the Rocky Mountain Locust reached Missouri in 1874, I predicted that it would come into the western counties too late to do any very serious damage, and that it would not reach beyond a given line. To the many anxious correspondents who, fearing that the State was to be overrun, as Kansas was being overrun, wrote for my opinion and advice, I replied: "Judging of the future by the past, the farmers of Missouri, east of the extreme western tier of counties, need fear nothing from locust invasions. They may plant their fall grain without hesitation, and console themselves with the reflection that they are secure from the unwelcome visitants which occasionally make their way into the counties mentioned, especially into those of the northwest corner of the State. The same holds true of the farmers of Illinois and of all the country east of a line drawn at a rough estimate, along longitude  $17^{\circ}$  west from Washington."

This prediction was fully borne out by subsequent events, and I have ever insisted that east of the line indicated there is no danger from this locust.

But, it will be asked, "Upon what do you base this conclusion, and what security have we, that at some future time the country east of the line you have indicated may not be ravaged by these plagues from the mountains?" I answer, that during the whole history of the species as I have attempted to trace it in the chronological account already given, the insect never has done any damage east of the line indicated, and there is no reason to suppose that it ever will do so for the future. There must of course be some limit to its flight, as no one would be foolish enough to argue that it could, in one season, fly to England or France, or even to the Atlantic ocean; and as its flight is by law limited to one season—for the term of life allotted to it is bounded by the spring and autumn frosts—so its power of flight is limited. And as the historical record proves that it never has done any damage east of the line indicated, it is but logical to infer that it never will, so long as the present conditions of climate and the present configuration of the continent endure. It is an interesting fact that whether on the Gulf of Mexico or in British America the eastern limit-line is approximately the same.

"But why," it will again be asked, "will not the young from the eggs laid along the eastern limit you have indicated, hatch and spread further to the eastward?" Here, again, historical record serves us, and there are, in addition, certain physical facts, which help to answer the question. In Chapter V it is shown, that the young insects do not reach, on an average, ten miles east of any point where they hatch, and that upon acquiring wings they fly in the main northwestwardly.

East of color-line indicated in Plate I, they did not reach in a general way, either in 1874 or 1876, and beyond that line I do not believe they will ever do any damage. Not



that they may not to some extent spread beyond that line, in years to come, or that the young, hatching from invading swarms may not exceptionally push beyond it ; for I have numerous records to show that the insects have occurred as far as the western point of Lake Superior, and that they have even reached the Mississippi in parts of Iowa : but in all such instances they appeared in scattering numbers only, and did no material damage. They were the last remnants of the mighty armies from the mountains, moving and blowing about, diseased, parasitized, intestate and wasting away.

It is an interesting fact, as shown by the distribution of timber in the United States, that this limit-line follows, in the main, the separation of the timber from the plains and prairie regions, or, more correctly speaking, the line which separates that vast region between the Mississippi and the mountains in which the timber averages not more than six or seven out of every one hundred acres, and that in which it averages twenty-five or thirty out of every one hundred. In this fact we also get another probable explanation of the eastern limit of injury by *spretus*.

Well is it for the people of the Mississippi Valley that this insect can not go on multiplying indefinitely in their fertile fields ! Else, did it go on multiplying and thriving as the Colorado Potato-beetle has done, this whole valley would soon become a desert waste.

It will be a source of satisfaction to the farmers east of the line indicated (however little it may be to those on the westward side,) to feel assured against any future invasion by, or any serious injury from, an army of insects so prodigiously numerous as actually to obscure the light of the sun, and so ruinously destructive as to devour almost every green thing that grows !

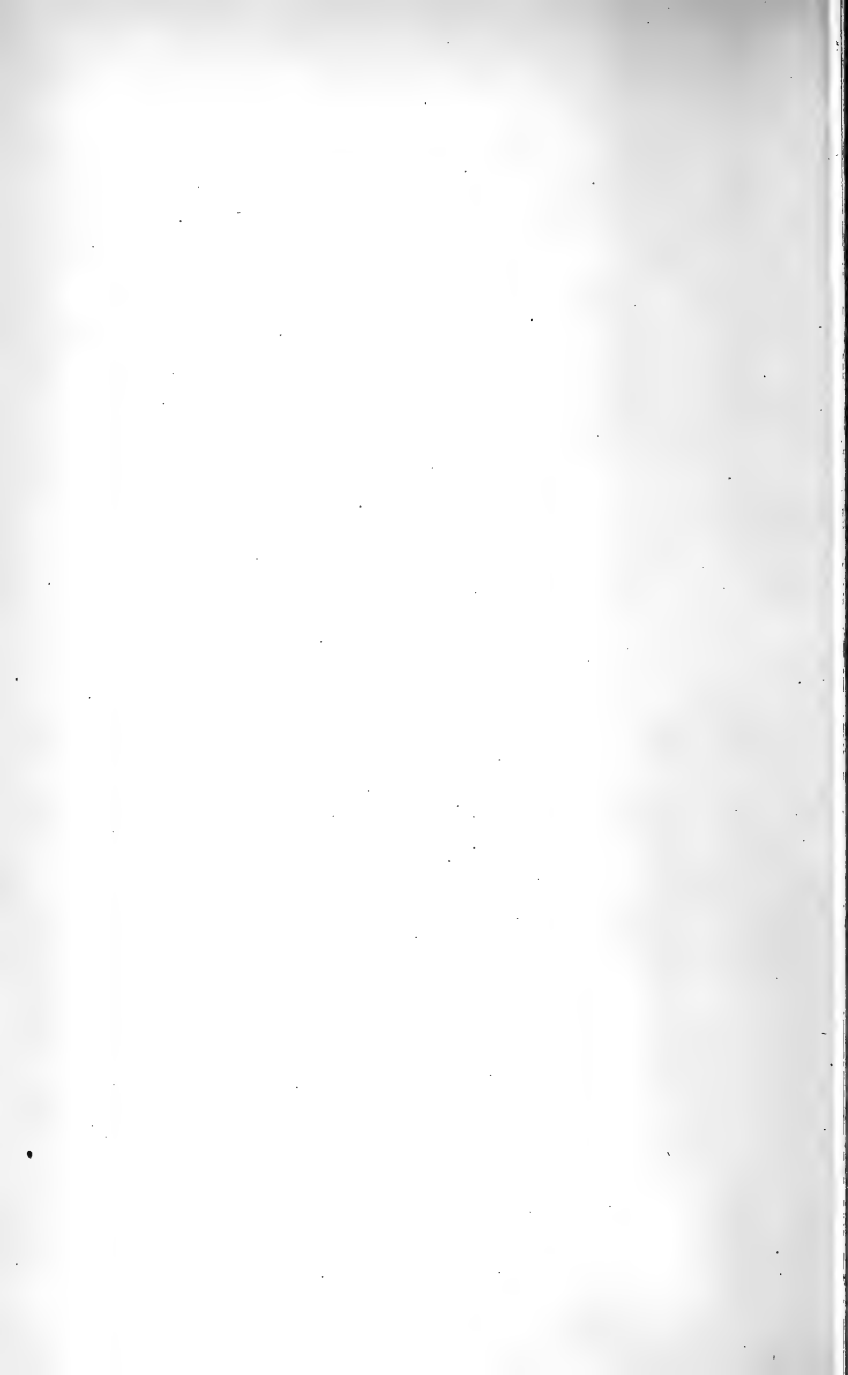

## CHAPTER IV.

### NATURAL HISTORY AND TRANSFORMATIONS.

#### HOW THE EGGS ARE LAID.

THE female, when about to lay her eggs, forces a hole in the ground by means of the two pairs of horny valves which open and shut at the tip of her abdomen, and which, from their peculiar structure, are admirably fitted

[Fig. 6.]

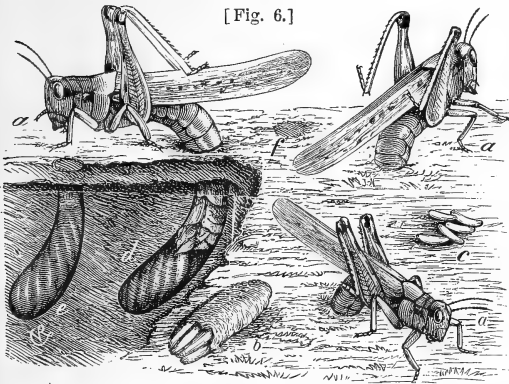

ROCKY MOUNTAIN LOCUST:—*a, a, a*, female in different positions, ovipositing; *b*, egg-pod extracted from ground, with the end broken open; *c*, a few eggs lying loose on the ground; *d, e*, show the earth partially removed, to illustrate an egg-mass already in place, and one being placed; *f*, shows where such a mass has been covered up.

for the purpose. (See Fig. 7, where *b, c*, show the structure of one of each of the upper and lower valves). With the valves closed she pushes the tips into the ground, and by a series of muscular

efforts and the continued opening and shutting of the valves, she drills a hole until in a few minutes (the time varying with the nature of the soil) nearly the whole abdomen is buried. The abdomen stretches to its utmost for this

purpose, especially at the middle, and the hole is generally a little curved, and always more or less oblique (Fig. 6, *d*). Now with hind legs hoisted straight above the back, and the shanks hugging more or less closely the thighs, she commences ovipositing. If we could manage to watch a female during the arduous work of ovipositing, we should find that, when the hole is once drilled, there commences to exude at the dorsal end of the abdomen, from a pair of sponge-like exsertile organs (Fig. 8, *h*) that are normally retracted and hidden beneath the super-anal plate (Fig. 8, *i*), near the cerci, a

[ Fig. 7. ]

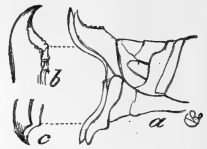

ROCKY MOUNTAIN LOCUST:—Anal characters of female, showing horny valves.

frothy, mucous matter, which fills up the bottom of the hole. Then with the two pairs of valves brought close together, an egg would be seen to slide down the oviduct (*j*) along the ventral end of the abdomen, and guided by a little finger-like style\* (*g*) pass in between the horny valves (which are admirably constructed, not only for drilling, but for holding and conducting the egg to its appropriate place) and issue at their tips amid the mucous fluid already spoken of. Then follows a period of convulsions, during which more mucous material is elaborated, until the whole end of the body is bathed in it, when another egg passes down and is placed in position. These alternate processes continue until the full complement of eggs are in place, the number ranging from 20 to 35, but averaging about 28. The mucous matter binds all the eggs in a mass, and when the

[ Fig. 8. ]



OVIPOSITION OF ROCKY MOUNTAIN LOCUST

\* This is a simple process or extension of the sternite, and may be known as the egg-guide, or *gubernaculum ovi*.

last is laid, the mother devotes some time to filling up the somewhat narrower neck of the burrow with a compact and cellulose mass of the same material, which, though light and easily penetrated, is more or less impervious to water, and forms a very excellent protection (Fig. 9, *d*).

PHILOSOPHY OF THE EGG-MASS.

To the casual observer, the eggs of our locust appear to be thrust indiscriminately into the hole made for their reception. A more careful study of the egg-mass or egg-pod will show, however, that the female took great pains to arrange them, not only so as to economize as much space as possible consistent with the form of each egg, but so as to best facilitate the escape of the young locust; for if, from whatever cause, the upper eggs should fail to hatch, or should hatch later than the lower ones, the former would offer an impediment to the exit of the young in their endeavors to escape from these last, were there no provision against

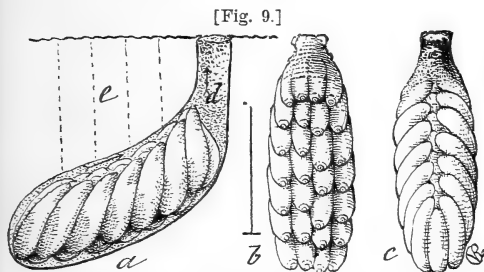

EGG MASS OF ROCKY MOUNTAIN LOCUST:—*a*, from the side, within burrow; *b*, from beneath; *c*, from above—enlarged.

such a possibility. The eggs are, indeed, most carefully placed side by side in four rows, each row generally containing seven. They oblique a little crosswise of the

cylinder (Fig. 9, *a*). The posterior or narrow end, which issues first from the oviduct, is thickened, and generally shows two pale rings around the darker tip (Fig. 10, *a*). This is pushed close against the bottom of the burrow, which, being cylindrical, does not permit the outer or two

side rows to be pushed quite so far down as the two inner rows, and for the very same reason the upper or head ends of the outer rows are necessarily bent to the same extent over the inner rows, the eggs when laid being somewhat soft and plastic. There is, consequently, an irregular channel along the top of the mass (Fig. 9, *c*), which is filled only with the same frothy matter which surrounds each egg, which matter occupies all the other space in the burrow not occupied by the eggs. The whole plan is seen at once by a reference to the accompanying figure, which represents, enlarged, a side view of the mass within the burrow, (*a*), and a bottom (*b*) and top (*c*) view of the same, with the earth which adheres to it removed.

DOES THE FEMALE FORM MORE THAN ONE EGG-MASS?

Whether the female of our Rocky Mountain Locust lays her full supply of eggs at once, and in one and the same hole, or whether she forms several pods at different periods, are questions often asked, but which have never been fully and definitely answered in entomological works. It is the rule with insects, particularly with the large number of injurious species, belonging to the Lepidoptera, that the eggs in the ovaries develop almost simultaneously, and that when oviposition once commences, it is continued uninterruptedly until the supply of eggs is exhausted. Yet there are many notable exceptions to the rule among injurious species, as in the cases of the common Plum Curculio and the Colorado Potato-beetle, which oviposit at stated or irregular intervals during several weeks, or even months. The Rocky Mountain Locust belongs to this last category, and the most casual examination of the ovaries in a female, taken in the act of ovipositing, will show that besides the batch of fully formed eggs then and there being laid, there are other sets, diminishing in size,

which are to be laid at future periods. This, I repeat, can be determined by any one who will take the trouble to carefully examine a few females when laying. But just how often, or how many eggs each one lays, is more difficult to determine. With *spretus* I have been able to make comparatively few experiments, but on three different occasions I obtained two pods from single females, laid at intervals of 18, 21 and 26 days respectively. I have, however, made extended experiments with its close congeners, *femur-rubrum* and *Atlantis*, and in two cases, with the former, have obtained four different pods from one female, the laying covering periods of 58 and 62 days, and the total number of eggs laid being 96 in the one case and 110 in the other. A number of both species laid three times, but most of them—owing, perhaps, to their being confined—laid but twice. They couple with the male in the intervals of oviposition, and I have no doubt but that, as in most other species of animals, there is great difference in the degree of individual prolificacy. We may, therefore, feel tolerably confident that the Rocky Mountain Locust will sometimes form as many as four egg-pods.

The time required for drilling the hole and completing the pod will vary according to the season and the temperature. During the latter part of October, or early in November last year, when there was frost at night and the insects did not rouse from their chilled inactivity until 9 o'clock A. M., the females scarcely had time to complete the process during the four or five warmer hours of the day; but with a higher temperature not more than from two to three hours would be required.

#### HOW THE YOUNG LOCUST ESCAPES FROM THE EGG.

Carefully examined, the egg-shell is found to consist of two layers. The outer layer which is thin, semi-opaque,

and gives the pale, cream-yellow color, is seen by aid of a high magnifying power to be densely, minutely and shallowly pitted; or, to use still more exact language, the whole surface is netted with minute and more or less irregular, hexagonal ridges (Fig 10, a, b). It is a mere covering of excreted matter, similar in nature to the mucous matter, already described, which binds the eggs together. The inner layer (or *chorion*) is thicker, of a deeper yellow, and perfectly smooth. It, also, is translucent, so that, as the hatching period approaches, the form and members of the embryo may be distinctly discerned through it. The outer covering is easily ruptured, and is rendered all the more fragile by freezing; but the inner covering is so tough that a very strong pressure between one's thumb and finger is required to burst it. How, then, will the embryo, which fills it so compactly that there is scarcely room for motion, succeed in escaping from such a prison? The rigid shell of the bird's egg is easily cracked by the beak of its tenant; the hatching caterpillar, curled within its egg-shell, has room enough to move its jaws and eat its way out; the egg-coverings

[Fig. 10.]

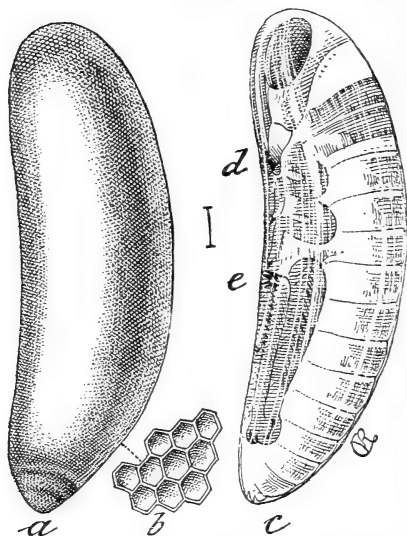

EGG OF ROCKY MOUNTAIN LOCUST:—a, showing sculpture of outer shell; b, the same, very highly magnified; c, the inner shell, just before hatching; d, e, points where it ruptures.

form and members of the embryo may be distinctly discerned through it. The outer covering is easily ruptured, and is rendered all the more fragile by freezing; but the inner covering is so tough that a very strong pressure between one's thumb and finger is required to burst it. How, then, will the embryo, which fills it so compactly that there is scarcely room for motion, succeed in escaping from such a prison? The rigid shell of the bird's egg is easily cracked by the beak of its tenant; the hatching caterpillar, curled within its egg-shell, has room enough to move its jaws and eat its way out; the egg-coverings

lowly pitted; or, to use still more exact language, the whole surface is netted with minute and more or less irregular, hexagonal ridges (Fig 10, a, b). It is a mere covering of excreted matter, similar in nature to the mucous matter, already described, which binds the eggs together. The inner layer (or *chorion*) is thicker, of a deeper yellow, and perfectly smooth. It, also, is translucent, so that, as the hatching period approaches, the



of many insects are so delicate and frail that the mere swelling of the embryo affords means of escape ; those of others are so constructed that a door flies open, or a lid lifts by a spring, whenever pressure is brought to bear : in some, two halves open, as in the shell of a muscle ; whilst in a host of others the embryo is furnished with a special structure, called the egg-burster,\* the office of which is to cut or rupture the shell, and thus afford means of escape. But our young locust is deprived of all such contrivances, and must have another mode of exit from its tough and sub-elastic prison. Nature accomplishes the same end in many different ways. She is rich in contrivances. The same warmth and moisture which promote the development of the living embryo, also weaken the inanimate shell, by a process analogous to decomposition, and by a general expansion consequent upon the swelling of the embryo within. Thus, the eggs when about to hatch are much more plump and somewhat larger and more transparent than they were when laid. At last, by the muscular efforts of the nascent locust, and the swelling of its several parts, especially about the head and mouth, the shell gives way, generally splitting along the anterior ventral part. The whole process may, in fact, be likened to the germination of a hard-covered seed, when planted in moist ground, and, precisely as in this latter case, there is, in some loose soils, a certain heaving of the ground, from the united swelling of the locust eggs. All the eggs in a given mass burst very nearly at one and the same time, and in that event the lowermost individuals await the escape of those in front of them, which first push their way out through the neck of the burrow (Fig. 9, *d*.) provided by the parent.

---

\* I have elsewhere (Mo. Ent. Rep. 9, p. 127.) called this the *Ruptor ovi*.

They all escape, one after the other, through one small hole, which in the field is scarcely noticeable. Such is the usual mode of hatching; but when the young from the lower eggs hatch first, or when the upper eggs perish and leave the lower ones sound—as is not unfrequently the case—the exit is nevertheless easily made along the channel already described (Fig. 9, *c*).

Where there is the heat requisite to insure development, but insufficient moisture to weaken the egg-shell, it is not improbable that another agency comes into play to aid the escape of the young.

Every one who has been troubled by it must have noticed that the shanks (*tibiæ*) of our locust, as of all the members of its family, are armed with spines. On the four anterior legs, these spines are inside the shank; on the long posterior legs, outside. The spines of the hind shanks are strongest, and the terminal ones on all legs stronger than the rest. There can be no doubt that these spines serve to give a firm hold to the insect in walking or jumping; but they may have first served a more important prenatal purpose by partially performing the office of egg-burster.

When fully formed, the embryo is seen to lie within its shell, as at Fig. 10, *c*. The antennæ curve over the face and between the jaws, which are early developed, and which, with their sharp, black teeth, reach down to the breast. The legs are folded up on the breast, the strong terminal hooks on the hind shanks reaching toward the mesosternum, or middle-breast. Ordinarily all these parts are sheathed in the delicate pellicle (*amnion*) presently to be described. But just in proportion as the hatching is retarded for want of moisture, after the embryo is once fully developed, in that proportion the jaws and spines harden; and it would seem that by the muscular contrac-

tions and expansions of hatching, which bring the ventral parts with great pressure against the shell, there might be slight friction of the horny points which would wear through the delicate *amnion* and facilitate the rupture of the shell at the points marked *d* and *e* in Fig. 10.

After this is ruptured, the nascent larva, by a series of undulating movements soon works itself entirely out of the egg-shell and makes its way to the light in the manner already described. Once fully escaped from the soil, it rests for a short time from its exertions. Its task is by no means complete : before it can feed or move with alacrity it must molt a pellicle\* which completely encases every part of the body. This it does in the course of three or four minutes, or even less, by a continuance of the same contracting and expanding movements which freed it from the earth, and which now burst the skin on the back of the head. The body is then gradually worked from its delicate covering until the last of the hind legs is free and the exuvium remains, generally near the point where the animal issued from the ground, as a little, white, crumpled pellet. Pale and colorless at first, the full-born insect in the course of half an hour assumes its dark-gray coloring.

From this account of the hatching process, we can readily understand why the female in ovipositing prefers compact or hard soil to that which is loose. The harder and less yielding the walls of the burrow, the easier will the young locust crowd its way out.

Though the covering which envelops the little animal when first it issues from the egg is quite delicate, it nevertheless in the struggles of birth undoubtedly affords protection from the burrow, and it is an interesting fact that

---

\* This pellicle (the *amnion*) is common to most insects. As a rule it is left with the *chorion*, but by most Orthoptera and Neuroptera it is shed after leaving the egg.

while it is shed within a few minutes of the time when the animal reaches the free air, it is seldom shed if, from one cause or other, there is failure to escape from the soil, even though the young locust may be struggling for days to effect an escape.

While yet enveloped in this pellicle, the animal possesses great forcing and pushing power, and if the soil be not too compact, will frequently force a direct passage through the same to the surface, as indicated at the dotted lines, Fig. 9, *e*. But if the soil is at all compressed it can make little or no headway, except through the appropriate channel (*d*). While crowding its way out, the antennæ and four front legs are held in much the same position as within the egg, the hind legs being generally stretched. But the members bend in every conceivable way, and where several are endeavoring to work through any particular passage, the amount of squeezing and crowding they will endure is something remarkable. Yet if by chance the protecting pellicle is worked off before issuing from the ground, the animal loses all power of further forcing its way out. The instinctive tendency to push upwards is also remarkable. In glass tubes, in which I have had the eggs hatching in order to watch the young, these last would always turn their heads and push toward the bottom whenever the tubes were turned mouth downward; while in tin boxes where the eggs were placed at different depths in the ground, the young never descended, even when they were unable to ascend on account of the compactness of the soil above.

#### GROWTH AND TRANSFORMATIONS.

The little locust when first hatched is quite pale, but soon becomes mottled with gray and brown. Except in having a shorter, narrower prothorax, sloping roof-fashion

to a meridian ridge, and in lacking wings, the young locust scarcely differs in structure from its parent; and the perfect, winged form is gradually assumed through a series of five molts, during the first four of which the wing-pads become larger,

[Fig. 11.]

and during the last, from the pupa (Fig. 11, *c*), to the perfect state, the thorax becomes flattened, the wings are acquired, and the insect ceases to grow and is ready to procreate. The

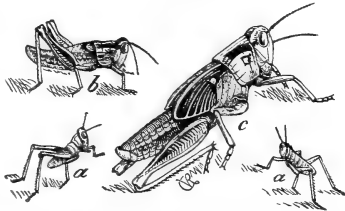

time required from hatching till the wings are obtained, differs very much according to latitude and season, but averages from six weeks to two months.

ROCKY MOUNTAIN LOCUST:—*a*, *a*, newly hatched larvæ; *b*, full-grown larva; *c*, pupa.

In order to illustrate the interesting process of molting we will trace an individual through the last molt—from the pupa to the winged insect—as it is the most difficult, and, on account of the larger size of the animal, most easily watched. The other molts are very similar, except that the wing-pads increase but moderately in size with each. When about to acquire wings the pupa crawls up some post, weed, grass-stalk, or other object, and clutches such object securely with the hind feet, which are drawn up under the body. In doing so the favorite position is with the head downward, though this is by no means essential. Remaining motionless in this position for several hours, with antennæ drawn down over the face, and the whole aspect betokening helplessness, the thorax, especially between the wing-pads, is noticed to swell. Presently the skin along this swollen portion splits right along the middle of the head and thorax, starting by a transverse-curved suture between the eyes, and ending at the base of the

abdomen. Let us now imagine that we are watching one from the moment of this splitting, and when it presents the appearance of Fig. 12, *a*. As soon as the skin is split, the soft and white fore-body and head swell and gradually

[ Fig. 12. ]

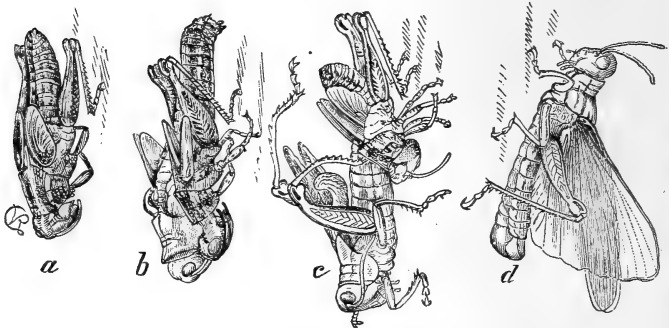

ROCKY MOUNTAIN LOCUST:—Process of acquiring wings. *a*, pupa with skin just split on the back; *b*, the imago extruding; *c*, the imago nearly out; *d*, the imago with wings expanded.

extrude more and more by a series of muscular contortions; the new head slowly emerges from the old skin, which, with its empty eyes, is worked back beneath; the new feelers and legs are being drawn from their casings, and the future wings from their sheaths. At the end of six or seven minutes our locust—no longer pupa and not yet imago—looks as in Fig. 12, *b*, the four front pupa-legs being generally detached and the insect hanging by the hooks of the hind feet, which were anchored while yet it had that command over them which it has now lost. The receding skin is transparent and loosened, especially from the extremities. In six or seven minutes more of arduous labor—of swelling and contracting—with an occasional brief respite, the antennæ and the four front legs are freed, and the full and crimped wings extricated. The soft front legs rapidly stiffen, and, holding to its support as

well as may be with these, the nascent locust employs whatever muscular force it possesses in drawing out the end of the abdomen, and its long hind legs (Fig. 12, *c*). This in a few more minutes is accomplished, and with gait as unsteady as that of a new-dropped colt, it turns round and clambers up the side of the shrunken, cast-off skin, and there rests while the wings expand and every part of the body hardens and gains strength—the crooked limbs straightening and the wings unfolding and expanding like the petals of some pale flower. The front wings are at first rolled longitudinally to a point, and as they expand and unroll, the hind wings, which are tucked and gathered along the veins, at first curl over them. In ten or fifteen minutes from the time of extrication these wings are fully expanded and hang down like dampened rags (Fig. 12, *d*). From this point on, the broad hind wings begin to fold up like fans beneath the narrower front ones, and in another ten minutes they have assumed the normal attitude of rest. Meanwhile the pale colors which always belong to the insect while molting have been gradually giving way to the natural tints, and at this stage our new-fledged locust presents an aspect fresh and bright (Fig. 13). If now we examine the cast-off skin we shall find every part entire, with the exception of the rupture which originally took place on the back; and it would puzzle one who had not witnessed the operation to divine how the now stiff hind shanks of the mature insect had been extricated from the bent skeleton

[Fig. 13.]



ROCKY MOUNTAIN LOCUST:—  
The imago with all parts perfect.

left behind. They are in fact drawn over the bent knee-joint, so that during the process they have been bent double throughout their length. They were as supple at the time as an oil-soaked string, and for some

time after extrication they show the effects of this severe bending by their curved appearance.

The molting, from the bursting of the pupa-skin to the full adjustment of the wings and straightening of the legs of the perfect insect, occupies less than three-quarters of an hour, and sometimes but half an hour. It takes place most frequently during the warmer hours of the morning, and within an hour after the wings are once in position the parts have become sufficiently dry and stiffened to enable the insect to move about with ease, and in another hour, with appetite sharpened by long fast, it joins its voracious comrades and tries its new jaws. The molting period, especially the last, is a very critical one, and during the helplessness that belongs to it the unfortunate locust falls a prey to many enemies which otherwise would not molest it, and not infrequently to the voracity of the more active individuals of its own species.

As already stated, there are five molts exclusive of that which takes place upon leaving the egg. In the first stage—that following the egg—the wing-pads are not visible; in the second stage they are likewise scarcely noticeable; in the third (after the second molt) they project but little beyond the meso- and meta-thorax, differ but little in size, and are directed downwards, lying separately close to the body; in the fourth stage (after third molt) they are directed upward, the hind covering and hiding more or less the front pair, and the joints bearing them retreating more beneath the prothorax; in the fifth stage (after fourth molt) they are enlarged as seen in the pupa, and with the fifth molt the sixth or perfect stage is attained.

European authors differ as to whether there are three, four or five molts in the European migratory species;\*

---

\* See Koeppen, "Ueber die Heuschrecken in Suedrussland," 1866. pp. 22-3.



but I have watched *spretus* from the egg to the imago, and thousands of mounted and alcoholic specimens of all ages show the stages enumerated. The transition from the second to the third, however, is often imperceptible, and it is not at all improbable that, as is the case with many other insects, the number of molts will vary according to the amount of nutrition and rapidity of development. The joints of the antennæ increase with each molt, from 13 in the newly hatched to 24 or 25 in the full-fledged insect.

#### FLIGHT AT NIGHT.

It is the very general experience throughout the country subject to invasion, that the winged insects rise, as soon as the sun begins to dissipate the dew, and that they come down again toward evening, as the sun's rays lose their power. It is a question, therefore, whether they ever continue flying during the night, and one which future investigation will doubtless settle. I am of the opinion that during the warmer mid-summer and early fall season, when the insects are departing from their northwest hatching grounds, they must not infrequently continue flight from necessity; for the descent of a swarm borne along in a strong current of air, at an altitude of over a mile above the earth, will depend more on some change in strength or direction of the current than on any other condition of the atmosphere.

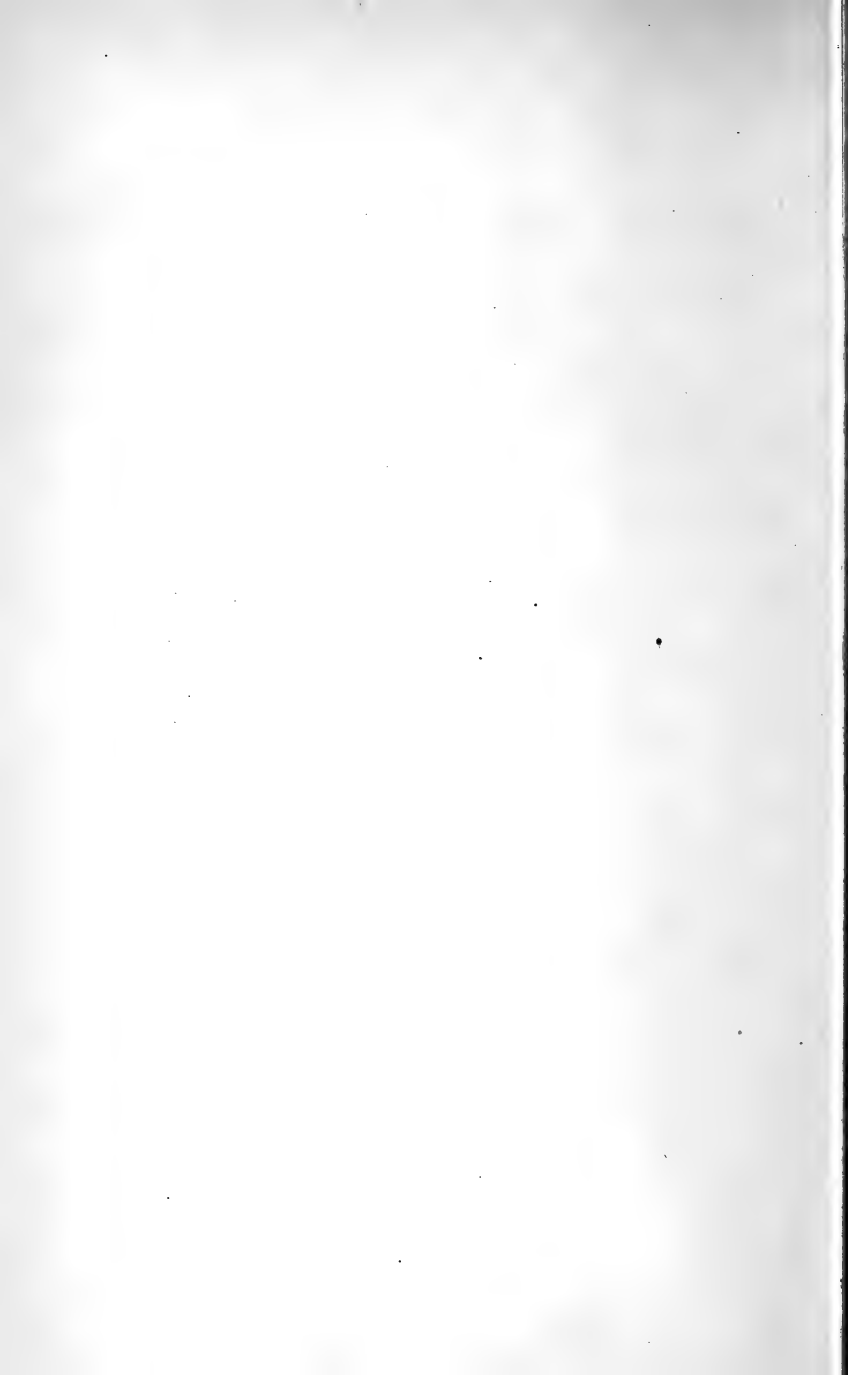

## CHAPTER V.

---

### HABITS, AND POWER FOR INJURY.

#### ITS FLIGHT AND RAVAGES.

THE voracity of these insects can hardly be imagined by those who have not witnessed them, in solid phalanx, falling upon a cornfield and converting, in a few hours, the green and promising acres into a desolate stretch of bare, spindling stalks and stubs. Covering each hill by hundreds; scrambling from row to row like a lot of young famished pigs let out to their trough; insignificant individually, but mighty collectively—they sweep clean a field quicker than would a whole herd of hungry steers. Imagine hundreds of square miles covered with such a ravenous horde, and one can get some realization of the picture presented in many parts of the country west of the Mississippi during years of locust invasion.

Their flight may be likened to an immense snow storm, extending from the ground to a height at which our visual organs perceive them only as minute, darting scintillations—leaving the imagination to picture them indefinite distances beyond. “When on the highest peaks of the snowy range, fourteen or fifteen thousand feet above the sea, I have seen them filling the air as much higher as they could be distinguished with a good field glass.”\* It is a vast cloud of animated specks, glittering against the

---

\* Wm. N. Byers, *Am. Entomologist*, I, p. 94.

sun. On the horizon they often appear as a dust tornado, riding upon the wind like an ominous hail storm, eddying and whirling about like the wild dead leaves in an autumn

[Fig. 14.]

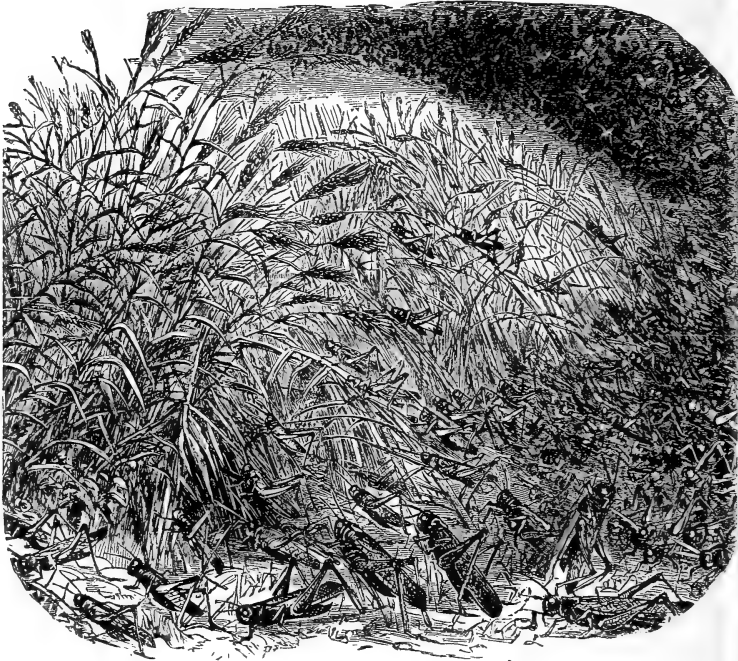

A SWARM OF LOCUSTS FALLING UPON AND DEVOURING A WHEAT-FIELD.

storm, and finally sweeping up to and past you, with a power that is irresistible. They move mainly with the wind, and when there is no wind they whirl about in the air like swarming bees. If a passing swarm suddenly meets with a change in the atmosphere, "such as the approach of a thunder-storm or gale of wind, they come down precipitately, seeming to fold their wings, and fall

by the force of gravity, thousands being killed by the fall, if it is upon stone or other hard surface.”\* In alighting, they circle in myriads about you, beating against everything animate or inanimate ; driving into open doors and windows ; heaping about your feet and around your buildings ; their jaws constantly at work biting and testing all things in seeking what they can devour. In the midst of the incessant buzz and noise which such a flight produces ; in face of the unavoidable destruction everywhere going on, one is bewildered and awed at the collective power of the ravaging host, which calls to mind so forcibly the plagues of Egypt.

The noise their myriad jaws make when engaged in their work of destruction, can be realized by any one who has “fought” a prairie fire, or heard the flames passing along before a brisk wind : the low crackling and rasping—the general effect of the two sounds, is very much the same. Southey, in his *Thalaba*,† most graphically pictures this noise produced by the flight and approach of locusts :

“ Onward they come, a dark, continuous cloud  
Of congregated myriads numberless,  
The rushing of whose wings was as the sound  
Of a broad river, headlong in its course  
Plunged from a mountain summit, or the roar  
Of a wild ocean in the autumn storm,  
Shattering its billows on a shore of rocks! ”

Nothing, however, can surpass the prophet Joel’s account of the appearance and ravages of these insects. Omitting the figurative parts, it is accurate and graphic beyond measure :

“ A day of darkness and of gloominess, a day of clouds and of thick darkness, as the morning spread upon the mountains ; a great people and a strong ; there hath not

---

\* Wm. N. Byers, Hayden’s Geol. Surv., 1870, p. 282.

† I., 169.

been ever the like, neither shall be any more after it, even to the years of many generations. A fire devoureth before them ; and behind them a flame burneth ; the land is as the garden of Eden before them, and behind them a desolate wilderness ; yea, and nothing shall escape them. The appearance of them is as the appearance of horses ; and as horsemen, so shall they run. Like the noise of chariots on the tops of mountains shall they leap, like the noise of a flame of fire that devoureth the stubble, as a strong people set in battle array. Before their face the people shall be much pained : all faces shall gather blackness. They shall run like mighty men ; they shall climb the wall like men of war ; and they shall march every one on his ways, and they shall not break their ranks.

\* \* \* They shall run to and fro in the city ; they shall run upon the wall, they shall climb up upon the houses ; they shall enter in at the windows like a thief."

Those who suffered from and witnessed the vast army that cast a blight over so large a portion of our Western country in 1874 and 1876 ; or who passed by rail, during the better part of two days, through a perfect storm of these insects, which frequently impeded or stopped the train by their crushed bodies reducing the traction—will concede that Joel's picture is not overdrawn, and that, though written over 2,500 years ago, it might have been inspired from many parts of North America in the years named.

THE MIGRATORY INSTINCT AND GREAT DESTRUCTIVE POWER  
BELONG TO BUT ONE SPECIES WEST OF THE MISSISSIPPI.

Being anxious to ascertain whether the injuries reported in the different parts of the country between the Mississippi and the Rocky Mountains were all caused by one species, or whether others joined their forces in devastat-

ing the country, I have taken some pains to procure specimens from as many different localities as possible. After examining such from every State and Territory in the country mentioned, from British America to the Gulf, it is obvious that in every instance it is the same species that proves such a scourge. As yet, we know nothing very definite about the species that has in the past done so much damage in California and other parts of the country west of the mountain range. Some suppose it to be the *Ædipoda atrox*, Scudder; but as *spretus* has been taken in Wyoming, Utah, Idaho and Nevada, this species, or a race of it, will doubtless be found to be the culprit.

Only occasionally do specimens of some of the more common species accompany the migratory one. Thus the larger and common species, the Two-striped Locust (*Caloptenus bivittatus*, Say) and the Differential Locust (*C. differentialis*, Walk.) which are incapable of migrating to any great distance, and which are common in the Mississippi Valley, have occasionally been caught with the *spretus*, and sent to me with it. Already existing in the country invaded by the Rocky Mountain species, they were simply gathered up with it.

Yet, while no other species possesses such wonderful migratory habits, several become so enormously multiplied during certain years in their native homes as to commit very serious injury to vegetation. Some of them are also capable of extended flight. Of these, I shall speak more fully further on.

#### FOOD PLANTS.

The Rocky Mountain Locust may be said to be almost omnivorous. Scarcely anything comes amiss to the ravenous hosts when famished. They will feed upon the dry bark of trees or the dry lint of seasoned fence planks; and

upon dry leaves, paper, cotton and woolen fabrics. They have been seen literally covering the backs of sheep, eating the wool ; and whenever one of their own kind is weak or disabled from whatsoever cause, they go for him or her with cannibalistic ferocity, and soon finish the struggling and kicking unfortunate. They do not refuse even dead animals, but have been seen feasting on dead bats and birds. Few things, therefore, come amiss to them. Yet where food is abundant they are fastidious and much prefer acid, bitter or peppery food to that which is sweet. The following *résumé* of my notes and observations may prove interesting : Vegetables and cereals are their main stay. Turnips, rutabagas, carrots, cabbage, kohlrabi and radishes are all devoured with avidity ; beets and potatoes with less relish, though frequently nothing but a few stalk-stubs of the latter are left, and sometimes the tubers in the ground do not escape. Onions they are very partial to, seldom leaving anything but the outer rind. Of leguminous plants the pods are preferred to the leaves, which are often passed by. Cucurbitaceous plants also suffer most in the fruit. In the matter of tobacco their tastes are cultivated, and they seem to relish an old quid or an old cigar more than the green leaf. Tomatoes and sweet potatoes are not touched so long as other food is accessible.

Of cereals, corn is their favorite ; if young and tender, everything is devoured to the ground ; if older and drier, the stalks are mostly left ; the silk is, however, the first part to go. All other cereals are to their taste, except sorghum and broom corn, which are often left untouched. The bearded varieties of wheat have been less damaged in Minnesota, by the winged insects, than the smooth varieties. They are fond of buckwheat and flax, but seldom touch castor beans except to feed upon the flower.



Next to vegetables and cereals, they relish the leaves of fruit trees; they strip apple and sweet cherry trees, leaving nothing but the fruit hanging on the bare twigs. The leaves of the peach are generally left untouched, but the flesh of the unripe fruit is eaten to the stone. Pear trees, as Prof. Gale informs me, suffered less than any other kind of orchard tree at the Experimental farm of the Agricultural College at Manhattan, Kansas. The tender bark of twig and branch and trunk of all these trees is gnawed and girdled, and these girdled trees present a sad picture as one passes through the ravaged country during the subsequent winter. Sour cherry, apricot and plum trees are less affected by them, while ripe fruit is seldom touched.

Of berries, strawberries and blackberries are devoured where raspberries are frequently unmolested. Flowering shrubs very generally suffer, and they are particularly fond of Rose and Lilac. Of herbaceous plants, Helianthus, Amaranthus and Xanthium are eaten with especial avidity. Grape vines suffer more from the girdling of the fruit-stems than from defoliation. Forest and shade trees suffer in different degrees, and some, when young, are not infrequently killed outright.

In 1874, Honey Locust, Red Cedar, Box Elder, Osage Orange, Elm and Oak, were either untouched or but little injured, while the following trees were preferred in the order of their naming: Ash, Willow, Cottonwood, Balm of Gilead, Silver-leaved and Lombardy Poplars, Black Ash, Black Locust, Black Walnut, Hickory, Ailanthus, Maple, Sumach and Evergreens. In every case they show a marked preference for plants that are unhealthy or wilted. In 1876 they in some cases showed a partiality for some plants that were passed by on other occasions, and their tastes are quite eccentric.

It is generally supposed that evergreens escape the ravages of the young insects, but wherever these are abundant, hemlock, arbor vitæ, the different pines, and especially the Norway spruce, for which they show a predilection, are stripped. The red cedar more often escapes. Wild prairie grass, especially that which is low, is eaten down less closely than other grasses, and oats more often escape than other cereals. Blue grass is sometimes killed out, but more generally not, and young corn is eaten down so often and so deeply into the ground that it is frequently destroyed. Potatoes are not killed by being eaten down, and generally make a crop after the insects leave, without replanting. This is especially the case when they are planted deep, and where the vines as they grow are at first kept covered with earth, which they can be with impunity. The blossoms and stems of peas are left after the leaves are stripped, and parsnips sometimes remain untouched. All other vegetables are swept off. Of wild plants, Milkweed, (*Asclepias*) and Dogbane (*Apocynum*) are little to their taste, and are taken only when all else is destroyed; an occasional *Salvia trichostemmoides* and *Vernonia noveboracensis* will also be left in the general ruin; but the plant of all others that enjoys immunity from the omnivorous creatures is the *Amarantus Blitum*, a low, creeping, glossy-leaved herb, lately introduced into Missouri. I found this plant unmolested even where the insects were so hard pushed for food that they were feeding on each other and on dead leaves, the bark of trees, lint of fences, etc., and where they were so thick hiding amid its leaves that fifty to a hundred occurred to the square foot. The immunity of the plant is the more remarkable since the other species of the genus do not escape.

The dislike of locusts for Leguminous plants is very general, and, as Mr. G. M. Dawson, of Montreal, Canada,

first suggested, there is probably a connection between this dislike and the large number of such plants found on the western plains.

In 1874, in Missouri, plants belonging to the Nightshade family (*Solanaceæ*) generally escaped their ravages; the tops of potatoes and tomatoes were not eaten. Sweet potatoes, parsnips, castor-beans, butter-beans, carrots, celery and the tops of beets were not molested. They did no damage to broom-corn or sorghum. Tobacco was in most cases not eaten, and if eaten, it is reported as killing the locusts. Prairie grass, wild weeds and the leaves of most forest trees were left uninjured. Plants growing in wet places, or in the shade of trees, hills, etc., mostly escaped injury. Finally, when pushed to extremities, there is only one plant—the little *Amarantus* above mentioned—that I have found that they will not touch.

#### INJURY TO FRUIT AND FRUIT TREES.

It is doubtful if grain-growers and stock-raisers suffer as much in the end as fruit-growers, from locust injuries. The injury is at first less felt by these, but in many instances it is more lasting and serious. Most trees survive one or two defoliations, but in many cases no leaves are permitted to grow for weeks, just at the season when they are most needed. This was especially the case in 1875 with low shrubs, such as gooseberries and currants, in which the insects were fond of roosting. Where not excessively numerous, heart-cherries were preferred over others, and the insects would pass through a strawberry bed and only clean out the weeds. A great many trees were killed outright, and it was often found necessary to cut down the grape-vines. Trees not killed were often badly barked and lost many limbs, and except where protected by ditches, no orchards yielded fruit. Many trees

put forth a few secondary blossoms after the insects left, and a few small apples were noticed on such in autumn.

TIME OF APPEARANCE OF INVADING SWARMS.

In endeavoring to deduce general conclusions respecting the time of year that the 1874 swarms reached different parts of the country, great difficulty was experienced in sifting those accounts which referred to the progeny of the 1873 invasion, and those which hatched within the insect's native range, and came from the extreme Northwest. The same was true of the fresh 1876 swarms, and those which hatched in Minnesota. Yet we shall find, as a rule, that the insects which hatch outside of what is designated further on as their native habitat—*i. e.*, in Minnesota, Iowa, Missouri, and the larger part of Nebraska, Kansas and Texas—acquire wings and leave before the fresh swarms from the mountain region appear. In the more northerly of the States, as in Minnesota, the insects hatched on the ground in ordinary seasons acquire wings in June, and earlier in proportion as we go south, until in Texas they become fledged in April. The time of appearance of the new swarms is in inverse ratio: *i. e.*, earlier in the more northern, later in the more southern States. Thus, while on the confines of the insect's native habitat, it is almost if not quite impossible to distinguish between the old and the new comers, in respect to the time of their acquiring wings, the difference in this respect becomes greater the farther south and east we go. In 1874, swarms appeared during June in Southern Dakota; during July in Colorado, Nebraska and Minnesota; during the latter part of this month in Iowa and Western Kansas. During August they came into Southeast Kansas and Missouri; and by the middle of October they reached Dallas, in Texas. In 1876 they came later.

One noticeable feature of the invasions is the greater rapidity with which the insects spread in the earlier part of the season, while in fullest vigor, and the reduction in the average rate of progress the farther east and south they extend. The length of their stay depends much upon circumstances. Early in the summer, when they first begin to pour down on the more fertile country, they seldom remain more than two or three days; whereas, later in the season, they stay much longer. In speaking of the advent and departure of these insects, I use relative language only. The first comers, when—after having devoured everything palatable—they take wing away, almost always leave a scattering rear-guard behind, and are generally followed by new swarms; and a country once visited presents for weeks the spectacle of the insects gradually rising in the air between the hours of 9 or 10 A. M. and 3 P. M., and being carried away by the wind, while others are constantly dropping.

RATE AT WHICH THE INVADING SWARMS SPREAD.

This may be illustrated by the history of the 1876 invasion. Leaving Montana about the middle of July, the insects reached far into Texas by the end of September, thus extending about 1,500 miles in 75 days, or an average of about 20 miles per day. But over a large part of this territory, viz., portions of Wyoming, most of Dakota and Nebraska, Western Minnesota, Northwestern Iowa, Northwestern Kansas, and Northeastern Colorado—they appeared almost simultaneously, or during the last few days of July and the first few days of August; and this, I think, indicates that they were at that time swept down at a very much higher rate by the northwesterly winds from Montana and British America. After that time the extension south was tolerably rapid, but the extension east was more and more

slow. They occupied nearly a month reaching from Northwestern Iowa to the southwestern limit in the same State, and their eastward progress on the confines of the limit-line already indicated was still more gradual as they went south. All of which indicates that they fly most powerfully when leaving the higher altitudes of the Northwest, and most persistently during the first week or so after becoming fledged, while the females are not yet prompted to descend for oviposition. This is also the period when they are passing over the vast plains and the sparsely settled and uncultivated portion of the country, in which there is, perhaps, least inducement for the ravenous host to halt.

As flight is not consecutive day after day, but often impeded by bad weather, and as it is not continuously in one direction, the average rate is not more than twenty miles a day. It is also most variable, and at times reaches a maximum of between two hundred and three hundred miles daily.

#### DIRECTION OF FLIGHT OF INVADING SWARMS.

The wind is sometimes quite changeable during the period of invasion, and we find the insects, at one time or another, traveling in nearly all possible directions, except due west. Yet the direction of the invading hosts has been, and I believe always will be, conspicuously toward the south and southeast. The exceptions are only sufficient to prove the rule.

#### WHERE THE EGGS ARE LAID.

The eggs may be laid in almost any kind of soil, but by preference they are laid in bare, sandy places, especially on high, dry ground, which is tolerably compact and not loose. It is generally stated that they are not laid in meadows and pastures, and that hard road-tracks are preferred; in truth, however, meadows and pastures, where

the grass is closely grazed, are much used for ovipositing by the female, while on well-traveled roads she seldom gets time to fulfill the act without being disturbed. Thus a well-traveled road may present the appearance of being perfectly honey-combed with holes, when an examination will show that most of them are unfinished, and contain no eggs ; whereas a field covered with grass-stubble may show no signs of such holes and yet abound with eggs. Furthermore, the insects are more readily noticed at their work along roads and roadsides than in fields, a fact which has also had something to do in forming the popular impression. Newly plowed land is not liked ; it presents too loose a surface ; but newly broken sward is often filled with eggs. Moist or wet ground is generally avoided for the purpose under consideration. During the operation the female is very intent on her work, and may be gently approached without becoming alarmed, though when suddenly disturbed she makes great efforts to get away, and extricates her abdomen in the course of a few seconds, the time depending on the depth reached.

#### TIME OF HATCHING.

The date at which the eggs hatch varies with the earliness or lateness of the spring, and is moreover quite irregular, some hatching in the same locality when the first-hatched locusts are getting wings. As a general rule, however, the bulk of the eggs hatch out in the different latitudes about as follows :

In Texas, from the middle to the last of March.

In the southern portions of Missouri and Kansas, about the second week in April.

In the northern parts of Missouri and Kansas and the southern sections of Iowa and Nebraska, the latter part of April and first of May.

In Minnesota and Dakota, the usual time of hatching

ranges from early in May in the southern portions to the third week in the northern extremity.

In Montana and Manitoba, from the middle of May to the first of June.

In short, the bulk of the insects hatch, in ordinary seasons, about the middle of March in latitude 35°, and continue to hatch most numerous about four days later with each degree of latitude north, until along the forty-ninth parallel the same scenes are repeated that occurred in Southern Texas seven or eight weeks before.

#### HABITS OF THE YOUNG OR UNFLEDGED LOCUSTS.

The habits of the young insects as they occur in the country south of the forty-fourth parallel and east of the one hundredth meridian, are as follows: Although possessed of remarkably active powers from the moment they leave the egg, yet so long as provision suffices for them on their hatching-grounds the young remain almost stationary and create but little apprehension. As soon, however, as the supply of food in these situations is exhausted, they commence to migrate, frequently in a body a mile wide, devouring, as they advance, all the grass, grain and garden-truck in their path. The migrating propensity is not developed until after the first molt, and often not till after the second or third. Up to that time they are content to huddle in warm places, and live, for the most part, on weeds, and especially on the common Dog-fennel or May-weed (*Maruta*) where it is present.

The young locusts display gregarious instincts from the start, and congregate in immense numbers in warm and sunny places. They thus often blacken the sides of houses or the sides of hills. They remain thus huddled together during cold, damp weather. When not traveling, and when food is abundant, or during bad, rainy weather, they are



fond of congregating on fences, buildings, trees, or anything removed from the moist ground. They also prefer to get into such positions to undergo their different molts. In fields they collect at night or during cold, damp weather, under any rubbish that may be at hand, and may be enticed under straw, hay, etc., scattered on the ground. Old prairie grass affords good shelter, and where a wheat-field is surrounded with unburnt prairie, they will gather for shelter along the borders of this last.

Their power for injury increases with their growth. At first devouring the vegetation in particular fields and patches in the vicinity of their birth-places, they gradually widen the area of their devastation, until at last, if very numerous, they devour every green thing over extensive districts. Whenever they have thus devastated a country they are forced to feed upon one another, and perish in immense numbers from debility and starvation. Whenever timber is accessible they collect in it, and after cleaning out the underbrush, feed upon the dead leaves and bark. A few succeed in climbing up into the rougher-barked trees, where they feed upon the foliage, and it is amusing to see with what avidity the famished individuals below scramble for any fallen leaf that the more fortunate mounted ones may chance to sever. This increase in destructiveness continues until the bulk of the locusts have undergone their larval molts and attained the pupa state. The pupa, being brighter colored, with more orange than the larva, the insects now look, as they congregate, like swarms of bees. From this time on they begin to decrease in numbers, though retaining their ravenous propensities. They die rapidly from disease and from the attacks of natural enemies, while a large number fall a prey, while in the helpless condition of molting, to the cannibalistic proclivities of their own kind. Those that acquire wings rise in the air during

the warmer parts of the day, and wend their way as far as the wind will permit toward their native home in the Northwest. They mostly carry with them the germs of disease or are parasitized, and wherever they settle do comparatively little damage.

#### DIRECTIONS IN WHICH THE YOUNG LOCUSTS TRAVEL.

The young insects move, as a rule, during the warmer hours of the day only, feeding, if hungry, by the way, but generally marching in a given direction until toward evening. They travel in schools or armies, in no particular direction, but purely in search of food—the same school one day often pursuing a different course from that pursued the day previous. On this point the experience of 1875 is conclusive, though the bulk of the testimony as to their actions, when hatching out in the States to the north and west, is to the effect that the prevailing direction taken is south or southeast, while in Southern Texas it is just opposite, or north. A person traveling along a road may often see one army marching in one direction to the left and another in the opposite direction to the right.

#### RATE AT WHICH THE YOUNG TRAVEL.

When about half grown they seldom move at a greater rate than three yards a minute, even when at their greatest speed over a tolerably smooth and level road, and not halting to feed. They walk three-fourths this distance and hop the rest. Two consecutive hops are seldom taken, and any individual one may be run down and fatigued by obliging it to hop ten or twelve times without a rest.

#### THEY REACH BUT A FEW MILES EAST OF WHERE THEY HATCH.

At the rate at which they travel, as just described, they could not extend many miles, even if they continued to

travel in one direction from the time of hatching until maturity. They travel, on an average, not more than six hours per day; and their unfledged existence terminates in from six to eight, say seven, weeks. It is very easy to calculate from these facts that if they continued in one direction from the time they hatch until they acquire wings, they could not extend thirty miles. In reality, however, they do not travel every day, and where food is abundant they scarcely travel at all. Moreover, as just shown, they do not commence traveling till after the first

[Fig. 15.]

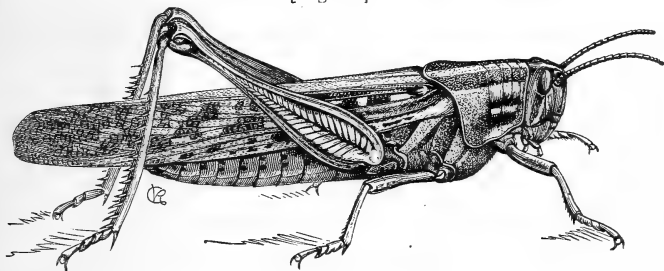

AMERICAN ACRIDIUM.

molt, and they do not go continually in a particularly eastern direction, but in all directions.

We have already seen that the winged insects take a north-west direction, and do not fly to the east. Yet in 1875 a few stragglers were carried as far as the centre of Missouri by being swept into the Missouri river and drifted on logs and chips during the annual rise of that river in July. These soon become lost to view; for most of them are intestate or diseased, and if they should lay eggs the young hatch early in the fall and perish at the approach of winter.

NOT LED BY "KINGS" OR "QUEENS."

The idea that the young hoppers were led in their marches by so-called "kings" or "queens" has been,

at different times, very prevalent. It is, however, quite unfounded. Certain large locusts belonging to the genera *Acridium* and *Ædipoda*, hibernate in the full grown, winged state, and not in the egg state, like the Rocky Mountain species. Always with us, their presence is simply more manifest in the spring, when the face of the earth is bare. Hopping with the others or falling into ditches with them, they give rise to this false notion, and it is an interesting fact, as showing how the same circumstances at times give rise to similar erroneous ideas in widely separate parts of the world, that the same idea prevails in parts of Europe and Asia.

The two species which are most often thus found with the young locusts and supposed from their size and conspicuousness to be guides, are the American *Acridium* (*Acridium Americanum*, Drury, Fig. 15), and the Coral-

[Fig. 16.]

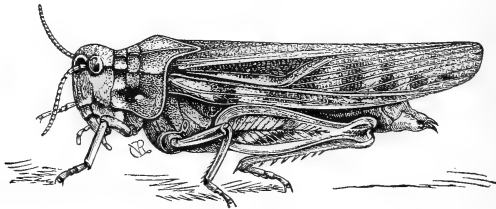

CORAL-WINGED LOCUST.

winged Locust (*Ædipoda phœnicoptera*, Germ., Fig. 16). The former is our largest and most elegant locust, the

prevailing color being dark brown, with a broad, pale yellowish line along the middle of the back when the wings are closed. The rest of the body is marked with deep brown, verging to black, with pale reddish-brown, and with whitish- or greenish-yellow; the front wings being prettily mottled, the hind wings very faintly greenish with brown veins, and the hind shanks generally coral-red with black-tipped, white spines. The species is quite variable in color, size and marks, and several of the varie-

ties have been described as distinct species. The Coral-winged Locust is also an elegant species, the colors being brown-black, brick-yellow inclining to brown, and a still paler, whitish-gray ; the hind wings varying from vermilion-red to pink, with more or less yellowish-green, and with a broad external dusky border, broadest and palest at tip. The hind shanks are yellow with black-tipped spines. This species is also quite variable, and at least half a dozen of its slight variations have been seized upon from which to fabricate new species.

DIRECTION TAKEN BY THE DEPARTING SWARMS.

While, as we have just seen, the principal direction of the invading swarms is south and southeast, the principal direction of the departing swarms is north and northwest. This is emphatically the case with those that rise from the lower Missouri Valley country. In other words, there is a return migration toward the home of the immediate parents. That the insects instinctively seek this direction there can, I think, be no doubt ; for while they depend in great part on the wind for propulsion, and without its aid would be unable to migrate to very great distances, I have a large number of reports to show that whenever the wind blew from the north or northwest, the locusts came down and awaited a change to a more favorable direction. They begin to rise when the dew has evaporated, and descend again toward evening. A swarm passing over a country yet infested with the mature insects, constantly receives accretions from these, and is, consequently, always more dense in the afternoon than in the forenoon. In rising, the insects generally face the wind, and it is doubtful if they could ascend to any great height without doing so. They are, I believe, good navigators, and know how to take advantage of the different air currents. The rate at which

they travel will depend on the force of the wind ; but it is evident from the observations made in Dakota, where their advance in 1875 was reported by telegraph, that they often travel a hundred miles a day. Their minimum speed, in tolerably calm weather, when the wind is scarcely felt at the surface of the ground, can not be much less than from eight to ten miles an hour.

In the more western and northern parts of the locust region, as in Minnesota, Dakota and Colorado, the direction of the departing swarms will be less constant, and according as they develop late, or are the progeny of swarms that came from other directions than the northwest, they will either be carried by the wind or will instinctively leave, in other directions.

#### DESTINATION OF THE DEPARTING SWARMS.

That the swarms which leave the fertile country in which they hatch and are not indigenous, pass by degrees to the northwest, and reach into Northwestern Dakota, Wyoming and Montana, the records clearly prove. That they also reach far up into the northwest regions of British America, the record of the flights of 1875 in Chapter II (p. 42) also abundantly attests. It is also just as certain that a large proportion of those which take wing perish on the way from debility, the effects of storms, and more particularly from the attacks of parasites ; because I proved by careful dissection in 1875 that a large proportion of those which came to maturity and left the western counties of Missouri, carried with them the germs of destruction in the shape of *Tachina* eggs or the larvæ already hatched and of various sizes. Others again were infested with the scarlet mites. We may very justly conclude, therefore, that a large proportion of the insects which depart from the country invaded, perish on their way

---

toward the native breeding grounds of the species, and that those which do not so perish reach the Rocky Mountain region of the Northwest, whence their parents had come the previous year. They are carried back with favoring winds, in thinned and weakened ranks, and those that did not start with the germs of disease, and which escape from other vicissitudes, doubtless succeed in reaching those conditions which favor the continued perpetuation of the species. They do comparatively little harm on the way, and are not, by any manner of means, to be likened to the more disastrous swarms from the opposite direction in the fall.

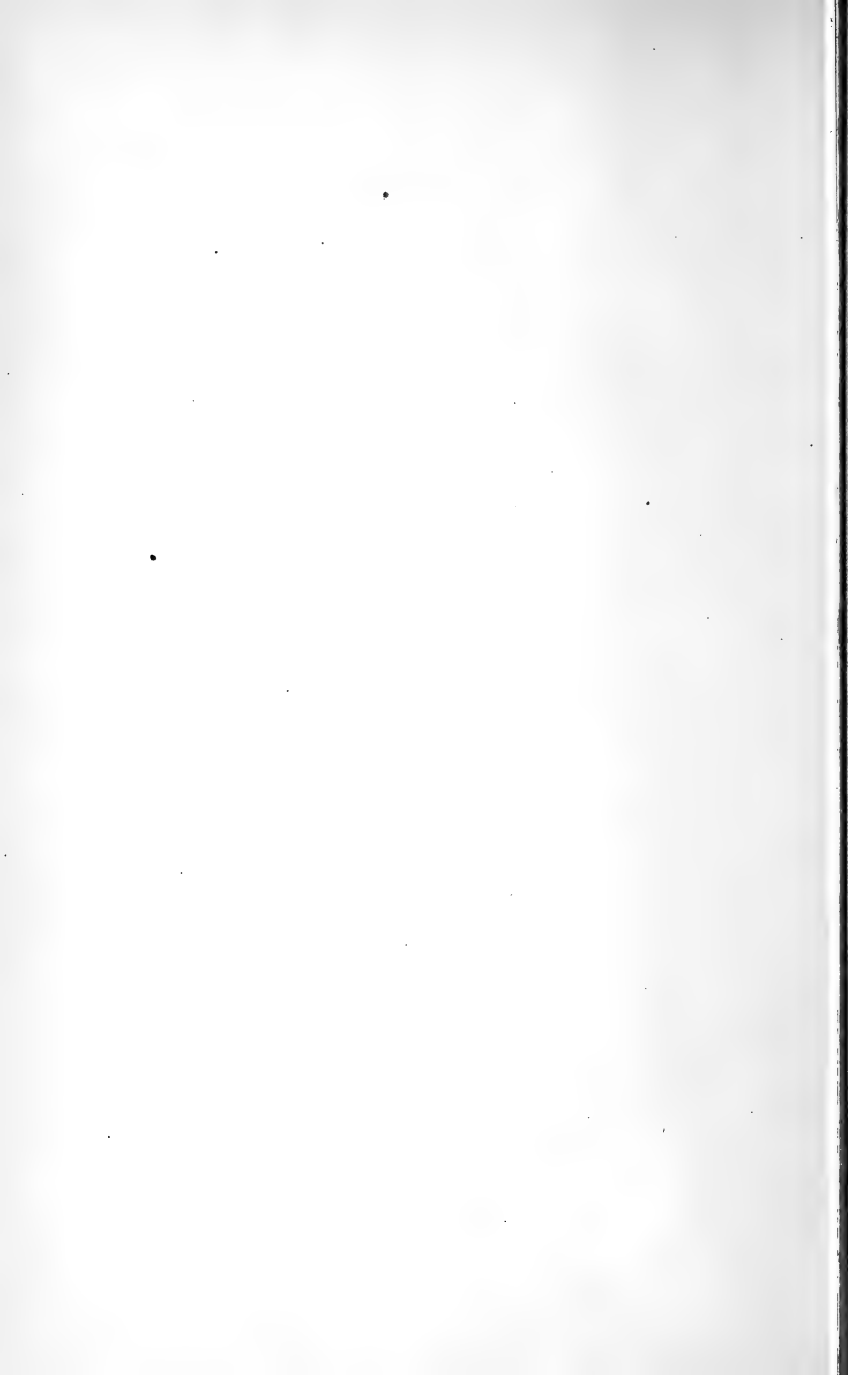



## CHAPTER VI.

---

### EFFECTS OF THE YOUNG INSECTS IN THE COUNTRY IN WHICH THEY HATCH, BUT ARE NOT INDIGENOUS.

#### EXPERIENCE WITH THE YOUNG LOCUSTS IN THE SPRING.

HAVING already spoken, in Chapter II, of the desolate aspect which the ravaged country sometimes wears toward the end of June, it will suffice in this connection to give a few of the more interesting experiences. It is recorded in Europe that few things, not even water, stop the armies of the young locusts when on the march, and Döngingk relates having seen them swim over the Dnjestr for a stretch of one and a quarter German miles, and in layers seven or eight inches thick.\* We have had similar experience with our own species. Mr. James Hanway, of Lane, Kansas, informs me that the young in 1875 crossed the Pottawatomie Creek, which is about four rods wide, by millions. The Big and Little Blues, tributaries of the Missouri—the one about one hundred feet wide at its mouth, and the other not so wide—were crossed at numerous places by the moving armies, which would march down to the water's edge, and commence jumping in, one upon another, till they would pontoon the stream, so as to effect a crossing. Two of these mighty armies met—one moving east and the other west—opposite a farm adjoin-

---

\* Koeppen, *loc. cit.*, p. 82.

ing Mr. Z. S. Ragan, of Independence, Mo., on the river bluff. Each turned its course north, and down the bluff, and, coming to a perpendicular ledge of rock twenty-five or thirty feet high, passed over in a sheet, apparently six or seven inches thick, at the same time causing a roaring noise similar to that of a cataract of water.

#### CONTRAST IN SUMMER AND FALL.

After the insects have left, or by the end of July in the latitude of St. Louis—earlier or later as we go south or north—the ravaged country begins to wear a bright and promising aspect, in strong contrast with the desolation of a month before. In August, the contrast becomes still more gratifying, and frequently there are grown the finest crops of corn, Hungarian grass, prairie meadow, buckwheat and vegetables of all kinds. In September, the change which three months have wrought needs to be seen to be appreciated. Root crops do well, and vegetables of all kinds attain immense proportions, owing to the freedom from weeds, and fertility resulting from the dung and bodies of the dead locusts.

#### NO EVIL WITHOUT SOME COMPENSATING GOOD.

Not to mention the valuable experience and the quickening influence that are generally gained in temporary adversity, there are other ways in which good may grow out of the locust troubles when they are severe. The chinch bugs filled the air in the spring of 1875, throughout the stricken district, and many persons feared that they would destroy the corn crop even if the locusts left. I then argued that there was no danger of such a result, and that there was every reason to expect less injury from this cause than usual, and with a wet summer, which might be expected, an almost total annihilation of the pest. With

everything eaten by the locusts, the female chinch, instead of being quietly engaged, unseen, in laying eggs, as they usually are in May, were flying about, seeking plants on the roots of which to deposit their eggs. For this reason, they were more noticeable. Once fully developed in the ovaries, the eggs must be laid, and the great bulk of them were necessarily laid where the young hatching from them were destined to perish, as the result proved; for, injurious as the species had been for the two or three previous years, scarcely a specimen was to be found in the fall. The same will hold true of many other insect pests, which are starved out in the spring by utter devastation of their food-plants; and such a devastated country is apt to be free from most noxious insects during the subsequent two or three years.

The unusual productiveness of the soil in the stricken country was on all hands noted during the year 1875, and was owing, in no small degree, to the rich coating of manure which the locusts left. In the form of excrement and dead locusts, the bulk of that which was lost in spring was left in the best condition to be carried into the soil and utilized. The introduction of new seed from other States was also beneficial.

Nature generally maintains her averages, and whenever diminished southern winds, drouth and locusts have prevailed, the opposite conditions are very apt to follow, and give us plenteous harvests in the place of short crops.

#### CHANGES THAT FOLLOW THE LOCUSTS.

The invasions into a country of large numbers of animals, whether men or insects, are often followed by changes in the vegetation of that country. Certain strange plants are said to yet mark the path through the Southern States which Sherman's soldiers took in their march to the sea,

and a number of plants new to the country are known to have been introduced into France by the Germans during the late Franco-Prussian war. So the locust incursions and devastations in Kansas and Missouri were followed by some curious changes. These changes consisted mostly in the great prevalence of plants that in ordinary seasons are scarcely noticed. The *Amarantus Blitum*, already spoken of, spread at an unprecedented rate, and grew in great luxuriance. Immediately after the locusts left, the common

[ Fig. 17.]



GREEN LARVA OF WHITE-LINED MORNING SPHINX.

purslane started everywhere and usurped the place of many other species. The common Nettle (*Solanum Carolinense*), and the Sand burr (*S. rostratum*), spread in 1875 to an alarming degree, and the Poke weed (*Phytolacca decandra*), was very abundant. All kinds of grasses grew very luxuriantly during the summer, a fact due to the wet and favorable weather; but some kinds\* that are rare in ordinary seasons, got the start and grew in great strength and abundance. Among these none are more notable than the sudden appearance very generally over the locust-devastated region, of what is usually called a new grass.

\* Prof. G. C. Brodhead (Trans. St. Louis Ac. Sc. III, p. 348,) mentions more particularly, *Aristida oligostachya*, in ordinary seasons of rare occurrence around Pleasant Hill, as reaching the unusual height of two feet, and being very abundant. *Eragrostis poaeoides*, ordinarily recumbent and scarcely noticed in yards and along roadsides, grew in profusion and three and a half feet high, "looking like meadows ready to be mowed." *Panicum sanguinale* was luxuriant enough to be cut for hay.

Springing up wherever the blue grass gets killed out, it proves a godsend to the people, for while it is young and tender, cattle like it and fatten upon it. This grass is the *Vilfa vaginæflora*, an annual which is common from the Atlantic to the Rocky Mountains. Unnoticed during ordinary seasons, the destruction of the blue grass and other plants by the too close gnawing of the locusts, gives it the advantage in the struggle for existence—an advantage which is soon lost, however, as the normal relations between species

[ Fig. 18.]

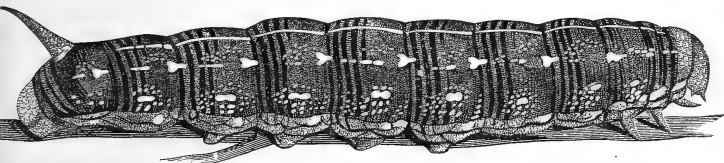

BLACK LARVA OF WHITE-LINED MORNING SPINX

are assumed again in a few years after the disturbing influence has ceased to be operative. Indeed, since the *Vilfa* ripens and dies early in the fall, the blue grass gains ground the very first year, and afterward easily retains supremacy. The wide-spread appearance of the *Vilfa*, following the locusts, has been explained on the hypothesis that the latter brought the seed from the West and passed it undigested with their droppings. The fact that the seed is a line long, and not particularly hard, aside from the other facts in the case, renders such a hypothesis unreasonable. Being an annual, the seed was scattered the previous fall, and naturally starting, we may presume, about the time the insects left, the species got the ascendancy.

Some persons were quite alarmed at the prevalence of large green and black worms, soon after the locusts left. Feeding upon purslane and prevailing to an unusual degree, because of the unusual prevalence of this plant,

they generally did good by keeping this weed down and converting it into manure. In some few instances, however, they swarmed to such an extent as to devour all the purslane, when they attacked grape-vines, and as Mr. Thos. Wells, of Manhattan, Kansas, informs me, even cut off corn when it was about a foot high. These worms were the variable larvæ of the White-lined Morning Sphinx, a pretty moth often seen hovering over flowers at evening. Most insects that naturally feed in spring above ground on

[ Fig. 19.]



WHITE-LINED MORNING SPHINX.

low vegetation were killed out, and the only species unaffected by the visitation were those feeding on forest trees, or living in the ground or in the trunks of trees. The White-lined Morning Sphinx, was just issuing from the pupa, which had remained undisturbed below ground, when the locusts were leaving. It found the Purslane—its favorite food-plant—everywhere springing up and abundant, and its eggs were laid without difficulty, and the young larvæ did not, in any case, lack for food. As a consequence they prevailed to a remarkable degree.

## CHAPTER VII.

---

### NATURAL ENEMIES OF THE ROCKY MOUNTAIN LOCUST.

#### BIRDS AND OTHER VERTEBRATE ANIMALS.

It is fortunate for man that, as in the case of most noxious insects, this locust is not without its numerous enemies. Chickens, turkeys and hogs devour immense quantities, and are happy during years of locust invasion, or whenever these insects abound. Prairie chickens and quails devour them with avidity, and even hunt for their eggs; swallows and blackbirds pursue them unrelentingly; the little snow birds devour great quantities of eggs when these are brought to the surface by the freezing and thawing of the ground; and the same may be said of almost all birds inhabiting the Western country in winter; for in the crops of warblers, plovers, snipe and other birds killed by the telegraph wires in the vicinity of Lawrence, Kansas, my friend, G. F. Gaumer, found these eggs last winter.

The good offices of birds are especially noticeable in spring, when the young locusts are hatching in the lower Mississippi Valley. Immense flocks of the different species of blackbirds, of the Lapland Longspur (*Plectrophanes lapponicus*) and of plover attend the hatching grounds, and clear entire fields. In 1875, Prof. F. H. Snow, of Lawrence, Kansas, found the young locusts in the gizzards of the Red-headed Woodpecker (*Melanerpes erythro-*

*cephalus*), Yellow-billed Cuckoo (*Coccygus Americanus*), Cat-bird (*Mimus Carolinensis*), Red-eyed Vireo (*Vireo olivaceus*), Great-crested Flycatcher (*Myiarchus crinitus*), and Crow Blackbird (*Quiscalus versicolor*), species that had not been noticed to feed on them before. The Shrike, or Butcher-bird, impales them upon thorns and other pointed substances ; and a number of other birds, as well as reptiles—*e. g.*, toads, frogs and snakes, and the Box-turtle—feed upon them ; while the Skunk, Striped Squirrel, and the Field Mouse do good work in devouring the eggs.

#### INVERTEBRATE ANIMALS.

The full-grown insects are not infrequently infested with a long, thread-like worm, well known by the popular name of "hair-worm," and erroneously supposed by many good people to be animated horse hairs. Specimens are often taken which are thrice as long as the locust from which they come. These belong generically to either *Gordius* or *Mermis*. Mr. G. F. Gaumer has examined several specimens infested with hair-worms, one of which was eighteen and a half inches long. I myself have taken a specimen six and a half inches long, which proves, upon comparison, to be our commonest species, *Gordius aquaticus*. But by far the most effective helps in weakening the vast armies of locusts are the parasitic and predaceous insects, albeit their work is perhaps less noticeable and less appreciated. Passing over the few—like certain species of Digger Wasps, belonging to the genus *Scolia*, which occasionally bury a few specimens as provision for their young ; various spiders ; the ferocious *Asilus* flies, which occasionally pounce upon a specimen, and suck out its juices, and the omnivorous ant, which sometimes feeds on the eggs, and on the weak, sickly and disabled hoppers—I will treat more particularly of those parasitic and predaceous species which



render effective service to man in destroying the locust. For practical purposes, these may be divided into those which attack the eggs and those which attack the active locust.

ANIMALS THAT ATTACK THE EGGS.

THE SILKY MITE (*Trombidium sericeum*, Say, Fig. 20.)— This is a small scarlet animal about two lines long, which has for some time been known to attack the eggs, and has particularly done good service in the more Northern States. In parts of Minnesota it has in many places reduced the eggs to a powder, and the ground has been alive with the little red, active bodies.

The accompanying figure represents one about half grown.

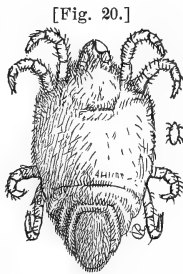

SILKY MITE:—Natural size at side.

This mite belongs to the genus *Trombidium*, only two N. A. species of which have been described viz., the *scabrum*, Say, and the *sericeum*, Say. The descriptions in both instances are very brief, and it is difficult to say whether the species in question belongs to either, as it varies considerably with age. It answers to *sericeum*, however, so far as the description goes, and I prefer to so refer it rather than describe it as new. The specimens which I have examined have not been full grown, and the pale red color which they possessed would doubtless have intensified with age. Every European is familiar with the Scarlet Mite (*T. holosericeum*, L), which is common in the soil of gardens in spring, and preys upon young larvæ of various descriptions. In color, silkiness and habit it greatly resembles our species, and may indeed be identical. All the species of this genus are highly colored, and the *Trombidium tinctorium* found in Guinea and Surinam is employed as a dye.

The eggs of the Silky Mite, which are small, spherical and pale red, are laid in the ground in a loose mass of nearly 200. They become pear-shaped before hatching, and the young mites are paler than the full grown individuals and have but six legs, the hind pair being atrophied. The following accounts of its work are worthy of place :

A discovery has been made of great interest. A small red bug or spider, about the size of a small kernel of wheat, is found in great numbers, creeping into the holes to the grasshopper eggs and eating the contents of the eggs voraciously. Great numbers were found in the act of eating the eggs, with empty egg-shells in the same nest. The extent of the little friends is not limited, but they have been seen in many localities in different directions in this place. Mr. J. D. Johnston, Antrim, proved conclusively that these red bugs are making sure work among the eggs — [*Madelia* (Minn.) *Times*, 1874.

Last evening, when we reached Worthington from Lake Shetek, there was quite an excitement in Worthington, owing to the fact that the citizens were generally convinced that a red parasite was destroying the grasshopper eggs. I examined the matter carefully myself, and became convinced that the destruction of the eggs in that immediate vicinity was well assured; but I determined not to write you and excite any hope until a further and more complete examination could be had. We therefore furnished our Bohemian friends with a bottle of the eggs and *their pests*, and the commission left in high spirits. We postponed further investigation until this morning, when I left and prosecuted the examination with vigor. The farmers in the vicinity knew nothing of these signs of deliverance until the visitors from Worthington reached them, and I feel safe in saying to you that in a circle of ten miles from Worthington there will scarcely be an egg left by to-morrow night. I send you a bottle herewith containing the cones and the parasites. We could scarcely find a cone or sack, except as they were indicated by the parasite on the surface; and each cone, which was not entirely destroyed, had from five to fifty of the red laborers at work upon the eggs. We found scores of cells with no eggs left, except the shells.

\* \* \* \* \*

I stopped for fifteen minutes one and a half miles west of Wilder, where Section Foreman Smith took me to that portion of his farm where eggs were deposited. We could find none by general digging, but wherever we found, as we frequently did, the red parasite on the surface, we found the cone beneath, with the parasite at work consuming the eggs. \* \* \* I am aware that two years ago this parasite was found working upon the eggs at Madelia and other places, but here we have the remedy almost as soon as the

eggs are laid, while in the former instances the parasite was only discovered in the spring.—[Letter from Ex-Gov. Stephen Miller, written from Windom, Minn., Aug. 15, 1876.]

We send herewith a box of grasshopper eggs, together with the "Silky Mite," of which so much has been said. You can see a sample of the work they are doing. They are over the ground and in it wherever eggs have been laid. They suck the eggs, leaving the bare shell. We have talked with farmers from all parts of the county, and they all tell the same story—not a cell to be found that is not partially or wholly destroyed.

We have personally inspected them in more than twenty different places, and are satisfied that in this county the eggs of the festive G. H. are a "total wreck." Allow us to suggest that you call for a report from every county in the State that has been infested by them.—[Letter to *Pioneer Press and Tribune*, from Bell & Gruelle, Worthington, Nobles Co., Minn., Aug. 16, 1876.]

I send, enclosed in a circular tin box, mailed with this, some dirt containing grasshopper's eggs, and also the *red mite* or *spider* that sucks them, as you will perceive on examination. I trust they will be received in good order. I send them at the request of A. Whitman, of St. Paul, of this State, with whom I am corresponding sometimes on this grasshopper matter.—[Letter from R. B. Potts, U. S. N., Worthington, Minn., Aug. 18, 1876.]

Up to the autumn of 1876 the Silky Mite was the only parasite that was known to attack the eggs of our locust, though a small Chalcid-fly\* had been bred by Mr. S. H. Scudder, from those of the Carolina Locust, a large species with blue and black hind wings; and two Ichneumon-flies were known to attack locust eggs in Europe. In 1876 I found five new insect enemies attacking these eggs almost everywhere throughout the infested country, and these I will proceed to describe.

---

\* Proc. Bost. Soc. Nat. Hist., XII, p. 99. Mr. Scudder has kindly furnished me with female specimens. They are about 0.20 inch long, pitchy black, the head and thorax very deeply pitted and roughened, and the abdomen, which is flattened and quite tapering, also deeply marked with irregular, longitudinal depressions. The antennæ have the scape as long as the flagellum, which is curved and enlarges to tip, which is suddenly docked. The scape, basal joint of flagellum and legs are honey-yellow; the wings hyaline.

A similar, if not the same Chalcid, infests the eggs of *spretus*, for Mr. Potts has sent me egg-masses in which every egg had a Chalcid pupa. Unfortunately, they were too dry when received to permit of rearing the imago.

THE ANTHOMYIA EGG-PARASITE, (*Anthomyia radicum*, var. *calopteni*.)—This is by far the most wide-spread and generally useful of the different egg enemies. It has occurred in Minnesota, Iowa, Nebraska, Kansas, Missouri and Texas, and wherever I have examined the locust eggs,

[Fig. 21.]

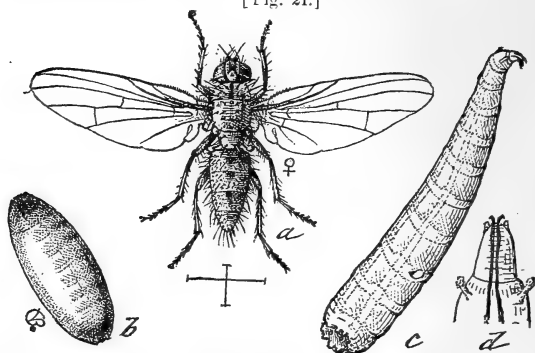

ANTHOMYIA EGG-PARASITE:—a. fly, b. pupa c. larva from side, d. head of same from above—enlarged.

whether in Missouri, Kansas or Nebraska, I have found it destroying on an average about ten per cent. of them.

The following items will serve as samples of many others that might be given, referring to the work of this same parasite :

Recently a white worm or maggot has been discovered in the locust eggs laid in this vicinity, and so general are the grubs that we really look for a great diminution in next year's locust crop. About the time the hoppers began laying eggs we had a hard, soaking rain, and since then we have had several more—the last this morning. By this time the ground is well soaked with water and the eggs were and are laid in earth that is quite moist. It is about two weeks since the hoppers first reached Mankato, they have laid many eggs, and already this worm or maggot has developed and seems to be on the increase, being found in the egg cells, where it sucks or destroys the egg. Some cells that I have opened have had two and three worms in them.—[From a letter from J. C. Wise, Mankato, Minn., August 20, 1876.

On the ninth I sent you a box of locust egg parasites, and to-day I will send you some more of different sorts or different stages of de-

velopment or both. I find them more plentiful to-day than before. The ground seems to be full of them, from five to twenty of the small white worms in a single cell, one generally, though sometimes two of the large white ones in a cell. The reddish colored ones I suppose are in a different stage of development, though the same parasite. In every cell in which I have found any of those sent you, the eggs were nearly or quite destroyed. But there is another, and a far more destructive enemy, viz., the hot sun, which is hatching them out by the million, though the parasites may continue their work after it ceases to operate. I shall be happy to do all I can to aid you in your investigations.—[Letter from C. E. Treadwell, Rockport, Atchison county, October 16, 1876.]

Yesterday we discovered on a warm southern exposure that our locust eggs were hatching out maggots. We break open the cocoons and the eggs on exposure to the sun for a few moments crawl away a worm. In warm places along the hedges the earth is alive with them. Is this a new development of the locust question? It would seem to be a confirmation of the theory you promulgated, as I understood it, at the time. I secured a few of the perfect cocoons which I enclose for your examination. We suppose these will do as the others do upon exposure to the sun.

The people here are quite excited over the matter, hoping it may be a solution of the problem for next year, at least, and have deputed me to lay the matter before you. Any information you can give us in regard to this our latest development, will be thankfully received and acknowledged.—[Letter from S. M. Pratt, M.D., Hiawatha, Brown County, Kansas, October 30, 1876.]

Various reports have been circulated in regard to the destruction of the eggs of the Rocky Mountain Locust (*Culoptenus spretus*) by a worm. I am happy to state that these reports were substantiated yesterday by Mr. McLockhead, of Deer Creek, Kanawaka, twelve miles west of this city, who brought me a box of earth in which the eggs of the "hopper" had been abundantly deposited. To-day a similar box was secured from W. B. Barnett, Esq., of Hiawatha, Brown county. In both of these instances a large proportion of the eggs have been destroyed by a small, white larva. Many of the egg-cases, which ordinarily each contain from twenty to thirty eggs, had no eggs in them, but were full of these worms or larvæ, each one of which took the place of an egg which it had destroyed. Some of the egg-cases contained only two or three larvæ with more than twenty sound eggs. I consider these to be the larvæ of a parasitic Hymenopterous insect [it was subsequently verified as the *Anthomyia* under consideration] which I hope to obtain in the winged or perfect state, if I succeed in carrying them safely through their transformation.—[Prof. F. H. Snow, in *Lawrence* (Kansas) *Journal*, November 1, 1876.]

This good little friend, which simultaneously prevailed over so large an extent of country, is a small white mag-

got, (Fig. 21, *c*) of the same general form of the common meat maggots or "gentles," but measuring, when full grown and extended, not quite one-fourth of an inch in length. The head, with some of the anterior joints of the body, tapers and is retractile, and the jaws consist of two small hooks joined to a V-shaped, black, horny piece which, as it is retracted or extended, plays beneath the transparent skin. The hind or tail end is squarely docked off, and contains two small yellowish-brown, eye-like spots, which are the principal spiracles or breathing pores.

These small maggots are found in the locust egg-pods, either singly or in varying numbers, there sometimes being a dozen packed together in the same pod. They exhaust the juices of the eggs, and leave nothing but the dry and discolored shells; and where they are not numerous enough to destroy all the eggs in the pod, their work, in breaking open a few, often causes all the others to rot.

When fed to repletion, this maggot contracts to a little cylindrical, yellowish-brown pupa, (Fig. 21 *b*), about half the length of the outstretched and full-grown larva, and rounded at both ends. From this pupa, in the course of a week in warm weather, and longer as the weather is colder, there issues a small, grayish, two-winged fly (Fig. 21 *a*), about one-fourth of an inch long, the wings expanding about one-half of an inch, and in general appearance resembling a diminutive house-fly, except that the body is more slender and more tapering behind, and the wings relatively more ample. More carefully examined, the body is seen to be of an ash-gray color, tinged with rust-yellow, and beset with stiff, bristle-like hairs, those on the thorax stoutest, and those on the abdomen smaller but more uniformly distributed. The wings are faintly smoky and iridescent. There are three dusky longitudinal stripes on the thorax, most distinct anteriorly, and another along the

middle of the abdomen, most distinct in the male, which also differs from the female in the larger eyes, which meet much more closely on the top of the head than in the female, and in the face being whiter.

The winter is passed mostly in the pupa state, though doubtless in some cases also in the winged state.

The flies of this genus are characterized by the shortness of the antennæ, and by the attenuated abdomen. The characters given to it are, however, by no means uniform, and as the species generally bear a very close resemblance to each other, and there have been a large number described in Europe (many of them very imperfectly), it becomes almost an impossibility to properly determine them. As the sexes often differ materially, it is also, except where they are reared from the larva, difficult to connect them; and as the colors often become sordid and dull in the cabinet, many of the described species have no real existence.

The flies frequent flowers, and often congregate and play in swarms in the air. Their eggs are white, smooth, oval, about 0.04 inch long, and are dropped near the food of the larva. In the larva state, these insects mostly feed on leguminous plants, and the carnivorous habit is exceptional. The species affecting the cabbage, the onion, the radish, etc., have received different names, as *brassicæ*, *ceparum*, *raphani*, etc., but several of them doubtless constitute but one species. A comparison of those reared from the locust eggs with the descriptions of *brassicæ* and *ceparum*, has not enabled me to discover any constant differences; and they should perhaps all be referred to *radicum*, Linn. At all events, I feel that it is safest to define the insect under consideration merely as a variety of that species, leaving the proper determination of it to the future monographer of the genus.

The probabilities are that, feeding normally on the roots of various plants, it found locust eggs to its liking, and multiplied rapidly as a result of the abundance of such eggs.

*ANTHOMYIA RADICUM* (Linn.) var. *CALOPTENI*.

*Egg*—Oval, smooth, white, 0.04 inch long.

*Larva*—Skin unarmed, 0.24 inch long when extended, of the normal form, the mandibular hooks black, quite conspicuous, and diverging at base. Prothoracic spiracles elongate. Anal spiracles minute, yellowish-brown, with the eight fleshy surrounding tubercles, small.

*Pupa*—Pale-brown, rounded at each end, with the prothoracic spiracles and lips anteriorly, and the anal spiracles and lower tubercles posteriorly, showing as minute points.

*Imago*—♀. Average expanse, 0.48 inch. General color ash-gray, with a ferruginous hue, especially above, and a more or less intense metallic reflection. Face with white reflections below; eyes smooth, brown, encircled by the ground color, and this behind and on forehead, bordered by a brown line; two similar lines at back of head from upper corners of eyes, and approaching to neck; forehead dusky brown, becoming bright yellowish-red toward base of antennæ, and the brown forking at right angles around occiput. Trophi and antennæ black, the style simple and somewhat longer than the whole antennæ. Thorax with three dusky longitudinal lines, obsolete behind; legs black, with cinereous hue beneath; wings faintly smoky, with brown-black veins, the discal cross-vein straight and transverse, the outer one bent and more oblique; balancers crumpled, yellowish. Abdomen with faint dusky medio-dorsal spots, broad at base, tapering and obsolescing toward end of each joint.

In the ♂, aside from the larger eyes, stronger bristles, and narrower, less tapering abdomen, with its additional joint—all characteristic of the sex—the face is whiter, and the medio-dorsal dark mark of abdomen continues.

Described from 25 specimens of both sexes, reared from locust egg-feeding larvæ.

Specimens bred from cabbage and radish roots, and others in my cabinet, taken from the burrows (made in Osage Orange, in Missouri), of *Crabro stirpicola*, Pack., do not differ specifically.



THE COMMON FLESH FLY (*Sarcophaga carnaria*, L.)—The red-tailed variety (*sarraceniæ*) of this ubiquitous insect, described and figured further on, as preying on the locust, also attacks its eggs. It is a larger maggot than the preceding, and contracts to a darker pupa which is not similarly rounded at each end, but has the hind end truncate, and the front end tapering. It sucks the eggs, as does the *Anthomyia* larva, but the parent fly is probably attracted principally to those which are addled or injured, as the pods in which I have found it have very generally been in a fluid state of decay. From three quarts of eggs I have obtained twenty-six of these flies.

UNDETERMINED SPECIES.—Next to the *Anthomyia* Egg-parasite in importance is a much larger, more sluggish,

yellowish grub (Fig. 22), measuring about half an inch when extended, which is found within or beneath the locust eggs, lying in a curved position, the body being bent so that the head and tail nearly touch each other.

It is a smooth grub, with a very small, brown, flat-

UNDETERMINED EGG-PARASITE OF R. M. LOCUST.

[ Fig. 22. ]

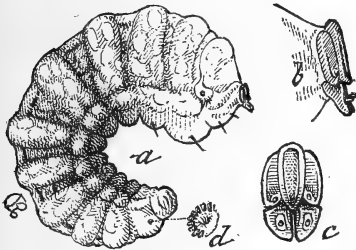

tened head, with the joints near the head swollen, and the hind end tapering, and with deep, translucent sutures beneath the joints, which sutures show certain vinous marks and mottlings, especially along the middle of the back. It exhausts the eggs, and leaves nothing but the shrunken and discolored shells. It has not yet been reared to the perfect state, but from the structure of its mouth it is evidently Hymenopterous, and will produce, without much doubt, some *Ichneumon*-fly. It has been found in

Minnesota, Iowa, Kansas and Missouri, and has destroyed about one per cent. of the eggs.

The following letters refer to this species :

The other day, as I was strolling through the fields, I stopped to examine some eggs. I found the ground in spots quite full of white grubs, worms or maggots, whatever they may be called. Many of them were in the egg-pods, busy at work. I collected a few, and sent to you in a small vial by mail for your examination. The ground was high and dry where found.—[From S. D. Payne, Kasota, Le Sueur County, Minn., Sept. 28, 1876.

I think the Silky Mite has done good service in destroying eggs in one or two counties, particularly Nobles. But we are getting, in addition, continual newspaper reports of white grubs destroying the eggs. I started out to see for myself, and have found a number, which I send you.—[From A. Whitman, St. Paul, Minn., Sept. 7, 1876.

This grub is found of various sizes as winter sets in, and hibernates without change. It will doubtless be reared to the perfect state the coming summer, and I give a more detailed description herewith.

Average length, 0.50 inch. Body curved, glabrous, tapering posteriorly, swollen anteriorly. Color opaque whitish, with translucent yellowish mottlings, and some vinous marks at sutures, especially along medio-dorsum. Sutures deep. A lateral row of swellings. Head small, flattened, dark-brown, in five pieces, consisting above of a frontal ovoid piece, and two lateral pieces of somewhat similar form, and each bearing near tip a minute, two-jointed palpus; beneath of two broad, sub-triangular jaws, having forward and lateral motion, and each also bearing near the center, in a depression, a two-jointed feeler. A spiracle each side in a fold between joints 2 and 3, and another on each side of the penultimate joint, 12. None otherwise perceptible.

Besides the three preceding species which were found destroying the eggs in 1876, and which, from their being generally found within the egg-pod, may be called parasitic, though they are not strictly so, I have also found the larvæ of two species of Ground-beetles (*Carabidæ*) attacking said eggs. One pale species (Fig. 23), evidently be-

longing to the genus *Harpalus*, is more particularly common, and busy in the good work. It is an active creature, something over half an inch long, with powerful jaws and a light-brown head and prothorax, and the rest of the body pale, tapering posteriorly, and ending in a stout proleg and two articulate appendages. For the entomological reader I append a more detailed description :

Color yellowish white; prothorax and head highly polished yellowish-brown, the jaws darker. Head broad, depressed and rugose in front; jaws broad, robust, dark, and with but one strong middle tooth; antennæ 5 jointed, joints 4 and 5 scarcely equaling 3 in length; maxillæ elongate, sub-cylindrical, with a 4-jointed outer and a 2-jointed inner palpus; mentum elongate, its base soldered with the

lower head; labrum also elongate and with 2-jointed palpi; all trophi armed with stiff hair. Prothoracic joint, swollen, wider than head, twice as long as succeeding joint, horny, and with a darker anterior border, limited by a transverse stria posteriorly and marked with fine longitudinal striæ. Legs, except coxæ, dark brown and thickly beset with short, spinous bristles of the same color. Abdomen tapering to end, with no horny plates, but each joint with two transverse rows of stiff yellowish hairs, the posterior rows strongest. Anal proleg stout, the cerci 4-jointed (joints 3 and 4 small and imperfectly separated) and reaching but little beyond it; eyes small, dark, and just behind base of antennæ. Length of largest specimens 0.58 inch.

Eight specimens feeding on eggs of *Caloptenus spretus*.

[ Fig. 23.]

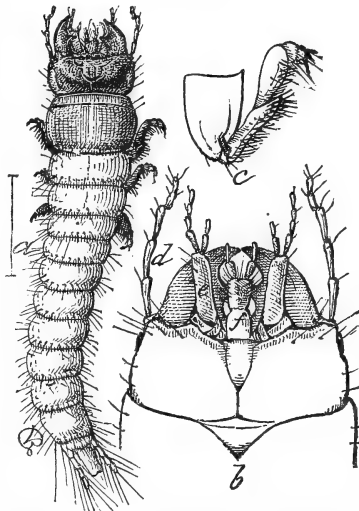

HARPALUS? LARVA THAT PREYS ON LOCUST EGGS.—a. larva from above, b. head, from beneath c. eg.—enlarged.

The other Ground-beetle, belonging probably to the same genus as the above, is of about the same size and has precisely the same structure. It is at once distinguished, however, by a series of broad, dark-brown, horny plates along the back, by paler horny pieces along the sides and beneath; by the darker, somewhat narrower prothorax; by

[Fig. 24.]

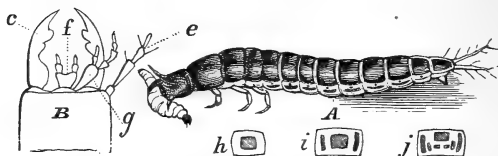

HARPALUS? LARVA:—B, under-side of head; h, i, j, under-side of different joints of body.

the pale legs, and by the shorter anal cerci. I have found three specimens of this last feeding on the eggs, and one was sent to me as having the same habit, by Mr. Whitman, of St. Paul. Mr. G. F. Gaumer has sent me what he took to be a minute Rove-beetle (*Staphylinidæ*) found feeding on the eggs, and they prove to be newly hatched specimens of the above *Carabid* larva.

It is probable that most of the *Carabid* larvæ will feed on the eggs, and I introduce the figure of a larger species (Fig. 24) and its probable parent, the Pennsylvania Ground-beetle (*Harpalus pennsylvanicus*, De Geer, Fig. 25). I have every reason to believe, also, that certain Click-beetle larvæ (*Elateridæ*) and certain Myriapods devour the eggs, while I have actually caught the common White Grub (larva of *Lachnosterna fusca*) feeding upon them.

#### INSECTS THAT DESTROY THE ACTIVE LOCUST.

In a general way it may be stated that all the larger predaceous species prey on the locusts. The Ground-beetles (*Carabidæ*) are conspicuous among these, and the Fiery Calosoma (Fig. 26) and the Elongate Ground-beetle.

(Fig. 27) are two of our largest and most common species.

[ Fig. 25.]

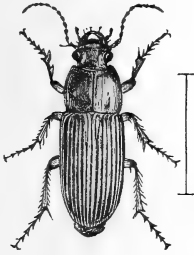

PENNSYLVANIA GROUND-BETLE.

[ Fig. 26.]

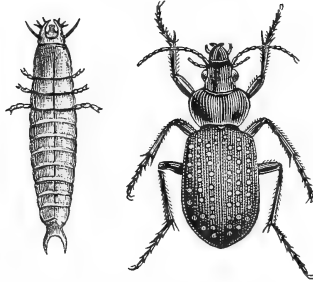

CALOSOMA CALIDUM, with larva.

Mr. H. A. Brous, who, while in Western Kansas in 1876, made careful notes of everything he observed relating to the Rocky Mountain Locust, has sent me a number of

[ Fig. 28.]

[ Fig. 27.]

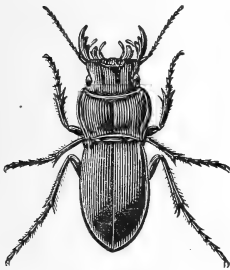

PASIMACHUS ELONGATUS.

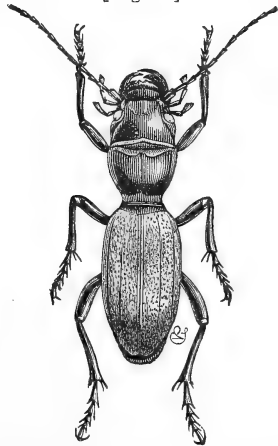

AMBLYCHILA CYLINDRIFORMIS.

insects found preying upon it that had not before been observed at such work. Among them are various Asilus-flies,\* and several

\* *Stenopogon consanguineus*, Loew, a species with pale yellowish hairs on head and thorax, yellowish-brown wings and pale rufous legs and abdomen; *Pro-machus apivora*, Fitch; *Erax Bastardii* (Fig. 29); several allied species of *Erax*, and a species of *Tolmerus*.

Ground-beetles and Tiger-beetles.\* More particularly noteworthy among these last is that large and most elegant dark-brown species which I herewith figure (Fig. 28), and which has been esteemed as a great rarity among Coleopterists. Mr. Brous found it much more common than it was generally supposed, and attributes its reputed

[ Fig. 29. ]

ERAX BASTARDII:—*a*, fly;  
*b*, pupa.

rarity to its secretive and nocturnal habits. It lives in holes in clayey banks, and issues in search of food only at night or early morn. Of Heteroptera, there is a Soldier-bug of the genus *Apiomerus* and allied to *crassipes*; and of Hymenoptera there are two Ichneumons—a *Compoplex* and *Ephialtes notanda*, Cress.—that were noticed pursuing the locusts, and are possibly parasitic upon them. The Preying Mantis

(*Mantis Carolina*, L.) has also been observed feeding on them.

The full grown locusts are subject to the attacks of the following parasites:

[ Fig. 30. ]

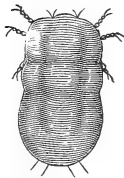
THE LOCUST  
MITE, greatly en-  
larged.

THE LOCUST MITE (*Astoma gryllaria*, LeBaron, Fig. 30.)—This mite, though insignificant in the matter of size, is nevertheless a most efficient enemy. Almost every one who has paid any attention to the locusts must have noticed that they are often more or less covered, especially around the base of the wings, with small red mites, seldom larger than the head of a pin. These mites have

\* *Pasimachus elongatus*, Lec.; *P. punctulatus*, Hald.; *Calosoma obsoletum*, Say; *Cicindela pulchra*, Say; *C. scutellaris*, Say; *C. 6-guttata*, Fabr.; *C. fulgida*, Say; *C. vulgaris*, Say; *C. circumpecta*, Laf.; *C. formosa*, Say; *C. punctulata*, Fabr.

but six legs which, though easily visible when the animal first attaches itself, become more or less obsolete and invisible as it swells and enlarges, though a careful examination will generally reveal them at the anterior end of the body. The mite, therefore, more often presents to the ordinary observer a bright red, swollen, ovoid body, so immovable and firmly attached by its minute jaws, that those who are not aware of its nature might easily be led into believing it a natural growth or excrescence. In fact, it attacks the locust precisely as the different wood-ticks attack man and the lower mammals.

This mite belongs to the genus *Astoma*, briefly characterized by Latreille for a very similar mite (*Astoma parasiticum*) which affects the common House-fly and several other insects. The specific name *locustarum* was first proposed for it by B. D. Walsh,\* but Dr. LeBaron afterwards gave it the name of *Atoma gryllaria*,† in connection with the following more detailed description :

They are of an oblong, oval form, moderately convex and having an uneven surface, produced by four shallow depressions on the upper side, the two larger near the middle, and the others behind them. The body has also two slight constrictions, giving it the appearance of being divided into three segments; but the impressions are superficial and only visible at the sides. The whole surface is finely striate, under the microscope, the striæ running in a waving transverse direction. The mouth-organs appear to be reduced to their minimum of development. The only part visible, externally, is a minute papilla, on each side of which are two bristles, the inner of which is stouter, tapering to an acute point, and curved inwards, or toward its fellow of the opposite side. They differ from the majority of Acarides in having but six legs, and these, being of but little use in so stationary a creature, are

---

\* *Practical Entomologist*, I, p. 126.

† LeBaron's 2nd Ill. Ent. Rep., 1872, p. 156. The author employs the term *Atoma*, which, though at first so employed by Latreille, is corrected to *Astoma* in his "Genera Crustaceorum et Insectorum," I, p. 162, (1806).

short and slender, projecting but little beyond the outline of the body. They are 6-jointed [in reality they are but 5-jointed, the middle joint much the shortest, and the terminal joint longest.—c. v. R.], garnished with short stiff bristles, and terminate in two slender, curved hooks. The anterior and middle legs are closely approximate and situated near the anterior extremity of the body; the posterior are set a little nearer to each other, and a little in advance of the middle of the body, being inserted at the posterior part of the anterior division or lobe. Four hairs project from the posterior extremity of the body.

[ Fig. 31.]



ASTOMA, parasite  
of the House-fly.

The dorsal figure just given (Fig. 30,) exhibits the general appearance of the mite under a high magnifying power, and figure 31 which represents a ventral view of the mite found on our house-flies, and which is doubtless the *A. parasiticum* of Latreille, will better show the structure of the head and legs. During some seasons scarcely a fly can be caught that is not infested with a number of these blood-red mites, clinging tenaciously around the base of the wings.

The genus *Astoma* (and the same is probably true of most other six-legged genera) is only the larval or immature form of some other mite; and this very Locust Mite may be the larva of the Silky Mite previously described, for aught we know to the contrary—so much is there yet to learn of the transformations of the mites. Indeed, Hermann, and some other arachnologists have actually referred *Astoma* to *Trombidium*. In speaking of the Irritating Harvest Mite (*Leptus irritans*, Riley, 6th Rep., p. 122)—the so-called Jigger of the Mississippi Valley, which is, in all probability, also an immature form—I have stated my belief that its normal food must, apparently, consist of the juices of plants, and that “the love of blood proves ruinous to those individuals who get a chance to indulge



it ; for unlike the true chigoe, the female of which deposits eggs in the wound she makes, these harvest mites have no object of the kind, and, when not killed at the hands of those they torment, they soon die—victims to their sanguinary appetite.”\* The same argument may, I think, be applied to the Locust Mite.

The Rocky Mountain Locust infested with this mite was sent to me in 1868 by Uriah Bruner, of Omaha, Neb., and in 1869 by Clark Irvine and C. Twine, of Oregon, T. K. Faulkner, of Whitesville, and Jno. P. Dopf, of Rock Port, Mo.,—the latter gentleman stating that it was fast causing a diminution in the ranks of the common enemy. I have also received it from Minnesota and Kansas, and found it on several of our native locusts ; while the following passage from an editorial account of the ravages of locusts in Kansas in 1869, which appeared in the *Prairie Farmer*, (Aug. 21, 1869,) is a sample of many newspaper accounts, and will show how efficient even a mite may be in killing:

The course of the locusts was brought to a sudden halt by the operation of some parasite, appearing in the shape of small red mites, which attach themselves to the body, under the wings, where they suck the carcass to a dry shell; the dead bodies of the grasshoppers almost covering some plants, where they have taken hold of a leaf or stalk, and clasped it, with a dead embrace; many others fall to the ground to die, too weak to rise again. In a half day's examination, where they were very thick, we failed to find more than two grasshoppers not so attacked, and this was not local; for a distance of thirty miles across the country they were found similarly affected.

THE ANONYMOUS TACHINA-FLY.—Our locust, like so many other insects, is also subject to the attacks of certain two-winged flies much resembling the common House-fly, but larger. One is the very same Tachina-fly (*Tachina anonyma*) which I have bred from a number of other insects.†

\* *Am. Naturalist*, Vol. VII, p. 19.

† See *Mo. Ent. Repts.*, 4, p. 129, and 5, p. 133.

I first reared this fly from specimens of the Rocky Mountain Locust sent me by Jos. C. Shattuck, Supt. of Public Instruction, Greeley, Col., who, July 14, 1873, wrote of its work as follows :

\* \* Also, I will say that the grasshoppers which a month since seriously threatened to devour every green thing, have met with a mortal foe and been slain by millions. (Don't think "millions" too large a word.) Very few have taken to "themselves wings and flown away," as heretofore, but lie dead in the fields they lately ravaged. A small fly pierces them and deposits an egg *while on the wing*, (or on the jump), and, like Herod of old, "they are eaten of worms and give up the ghost."

The following items refer to the same insect:

*A Grasshopper-Exterminating Fly.*—It seems that the grasshoppers that are so destructive to vegetation in many places in the central portion of the continent, are likely to find an enemy which threatens their rapid destruction. The Deer Lodge *Independent* says that a fly has made its appearance, closely resembling the common house-fly, but much larger, and of a gray, mottled color, which deposits its eggs under the wings of the grasshopper. The egg is enclosed in a glutinous substance, which secures it in its position until the worm is matured [embryon developed]. It then penetrates the body of the grasshopper, which speedily dies. The worm then burrows in the ground, and at the end of seventeen days comes forth a fly, ready to again commence the work of destruction. Mr. Wm. Walker, of Dempsey Creek, informs the *Independent* that twice during the past summer the grasshoppers threatened to destroy his crops, but the flies killed them so rapidly that they did him but little damage. As the grasshoppers were killed before depositing their eggs, it is generally believed that this plague is ended in the Deer Lodge Valley.—[Published in several Montana papers in the summer of 1874.

A great many of the locusts seemed to be punctured on the back, and on pulling their heads off after death (many were found dead) from one to three ordinary looking maggots would be found. Many farmers fear it might be an introduction of a new plague. May not this gentleman with his little gimlet in time prove the destroyer of the hateful locust?—[R. P. C. Wilson, Platte City, Mo., in private letter.

I saw a hopper kicking about as if he could hardly move; I pulled him to pieces and found that he contained a footless grub, half an inch in length. In a short time more were procured, placed in a covered tumbler, where, in a little more than two weeks, the grubs changed to Tachina flies, very much resembling the common house-flies. \* \* When we remember what an enormous number of eggs (fly-blows) a fly will lay, and that each, in about a month, will

be a perfect fly, it is seen that it would take but a few generations to clean out an army of grasshoppers.—[Oscar J. Strong, Rolfe, Pocahontas County, Iowa, in *Western Farmer*, Feb., 1869.

Mr. Byers, in speaking of the locusts hatching in Colorado in 1865, (*loc. cit.*) says: "That upon attaining about half their full size, they were attacked by a fly, which, stinging them in the back between the roots of the wings, deposited one or more eggs, which produced a large white maggot. The worm subsisted upon the grasshopper, finally causing its death, when it cut its way out and entered the earth. In this way probably half were destroyed, often covering the ground, and filling the furrows in plowed fields with their carcasses. The remainder, when their wings were sufficiently developed, took to flight, moving southeast, and we lost trace of them on the great Plains."

Mr. J. W. Crow, of Bigelow, Mo., in his correspondence with me, describes these maggots as infesting the "hoppers" in Holt county in the fall of 1876; and in 1869 I received the parasite from John P. Dopf, of Rock Port, Atchison County, Mo., and have bred it from the Differential Locust, figured further on, and from the Carolina Locust (*Ædipoda carolina*, L.) in St. Louis County.

Finally, Mr. S. E. Wilber, of Greeley, Col., has published an account of what is evidently the same fly.\* In this account, after showing how persistently the fly pursues the locust—leaving it no rest, and so effectually weakening whole swarms as to render them harmless—he expresses the opinion that the constant importunities and annoyances of this fly are the cause of locust migrations. While, however, they may constitute a factor in the result, such a conclusion is too sweeping.

The Yellow-tailed Tachina-fly (*Exorista flavicauda*, Riley, Fig. 32) which is so useful in destroying the Army-

---

\* Popular Science Monthly, IV, p. 745.

worm, will serve to illustrate the species, and, indeed, differs from it very little except in being somewhat larger, and in having the tip of the abdomen yellow.

These Tachina-flies firmly fasten their eggs—which are

[Fig. 32.]

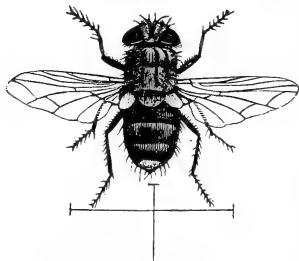

YELLOW-TAILED TACHINA-FLY.

oval, white and opaque, and quite tough—to those parts of the body not easily reached by the jaws and legs of their victim, and thus prevent the egg from being detached. The slow-flying locusts are attacked while flying, and it is quite amusing to watch the frantic efforts which one of them,

haunted by a Tachina-fly, will make to evade its enemy. The fly buzzes around, waiting her opportunity, and when the locust jumps or flies, darts at it and attempts to attach her egg under the wing or on the neck. The attempt frequently fails, but she perseveres until she usually accomplishes her object. With those locusts which fly readily, she has even greater difficulty; but though the locust tacks suddenly in all directions in its efforts to avoid her, she circles close around it and generally succeeds in accomplishing her purpose, either while the locust is yet on the wing, or, more often, just as it alights from a flight or a hop. The young maggots hatching from these eggs eat into the body of the locust, and after rioting on the fatty parts of the body—leaving the more vital parts untouched—they issue and burrow in the ground, where they contract to brown, egg-like pupæ, from which the fly issues either in the same season or not till the following spring. A locust infested with this parasite is more languid than it otherwise would be; yet it seldom dies till the maggots have left. Often in pulling off the wings of

such as were hopping about, the bodies have presented the appearance of a mere shell, filled with maggots; and so efficient is this parasite that the ground in parts of the Western States is often covered with the Rocky Mountain Locust dead and dying from this cause.

THE COMMON FLESH-FLY (*Sarcophaga carnaria*, Linn.)—This fly, which is at once distinguished from the Tachina-fly by the style of the antenna, being hairy

(Fig. 33, *i*), instead of smooth, is also a great enemy of the Rocky Mountain Locust, though I think it must be looked upon more as a scavenger than as an active parasite, and that it is attracted more especially to those

[ Fig. 33.]

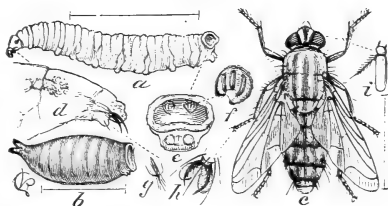

SARCOPHAGA SARRACENIÆ:—*a*, larva; *b*, pupa; *c*, fly, the hair lines showing average natural lengths; *d*, enlarged head and first joint of larva, showing curved hooks, lower lip (*g*) and prothoracic spiracles; *e*, end of body of same, showing stigmata (*f*) and prolegs and vent; *h*, tarsal claws of fly, with protecting pads; *i*, antenna of same—enlarged.

specimens which are feeble or already dead. I have received it among the Tachina parasites sent by Mr. Shattuck, from Colorado, and from Professor C. E. Bessey, of Ames, Iowa, who bred it from the Differential Locust, and published the following description of its work :

A COMMENDABLE FLY.—During the summer I noticed that many of the large yellow grasshoppers (*Caloptenus differentialis*) were infested by the maggot of a species of fly very nearly resembling, if not identical with, the common Flesh-fly (*Sarcophaga carnaria*.) Many of the grasshoppers were almost completely eaten out when found, retaining just sufficient strength to hop feebly over the ground. I estimate that this particular species of grasshopper was diminished in numbers at least one-tenth, possibly one-eighth, by these new friends. It is to be hoped that these new parasites will increase rapidly. Professor C. V. Riley informs me that the Migratory Locust (*Caloptenus spretus*) is also infested by a similar one. Thus far, however, I have failed to detect any in the specimens collected in this vicinity.

I have also bred it from a number of our native locusts whose carcasses—forsaken by the sarcophagous larvæ—may quite frequently be seen fastened to the upright stems of different plants in the fall of the year. I have also bred it from the common Carolina Mantis,\* which it attacked while living, and have known it to infest the common Walking-stick (*Spectrum femoratum*). Indeed, the species is a most widely-spread and general scavenger, occurring in most civilized countries, and feeding, as a rule, on dead and decaying animal matter, and only exceptionally on living insects. By way of illustrating its transformations, I introduce a figure of the Sarracenia Flesh-fly which feeds on the dead insects caught in those curious traps, the trumpet leaves (*Sarracenia*), and which is probably only a variety (*sarraceniæ*, Riley) of *carnaria*.† These flies lay elongate and delicate eggs, which hatch very quickly. They sometimes hatch, in fact, within the ovaries, so that the fly gives birth to living larvæ. These are distinguished from those of the Tachina-flies by being more concave and truncated at the posterior end (see Fig. 33, *a*). The Tachina larva is rounded posteriorly, with a

---

\* On the 18th of October, 1868, at South Pass, Ill., I found fastened to a tree a large female Mantis, still alive, but with the abdomen hanging down, partially decomposed and filled with *Sarcophaga* larvæ. These remained in the larva state in the ground till the next July, but gave forth the flies at the end of that month. The flies marked in my cabinet *Sarcophaga carnaria*, var. *mantivora*, differ in no respect from the common *carnaria*, except in size, seven not averaging more than 0.20 inch in length.

† The flies bred from *Caloptenus* have the tip of the abdomen reddish, as in *Sarcophaga sarraceniæ*, and indeed are undistinguishable from the smaller specimens of this last. The larva differs, however, in having the surface more coarsely granulated, it being regularly and uniformly covered with minute papillæ; in the less conspicuous, prothoracic spiracles; in the smaller but deeper anal cavity; and in the rim of this cavity having the twelve tubercles more conspicuous. The pupa also has the anal cavity smaller, more closed, but deeper; and the prothoracic spiracles less prominent. In these respects it agrees more closely with the typical *carnaria*, as described by Packard, and I have little doubt but all these differences are simply varietal.

---

small, spiracular cavity, easily closed and having a smooth rim: it contracts to a pupa, which is quite uniformly rounded at each end. The *Sarcophaga* larva is more truncate behind, with fleshy warts on the rim of the spiracular cavity, and with a more tapering head: it contracts to a pupa, which is also truncate behind, and more tapering in-front, where the prothoracic spiracles show as they never do in *Tachina*.

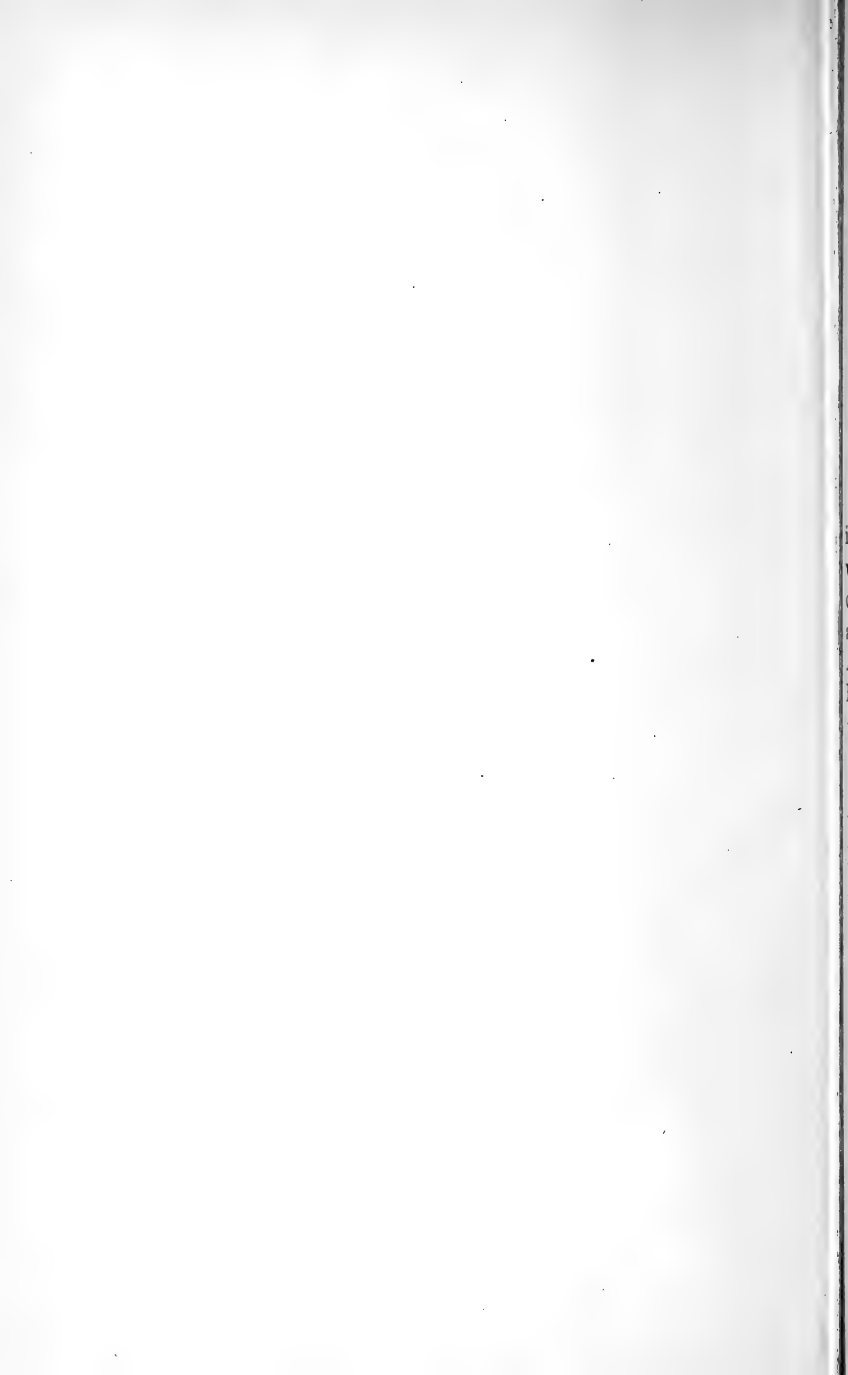



## CHAPTER VIII.

---

### PRACTICAL CONSIDERATIONS.

#### HOW BEST TO PREVENT LOCUST INJURIES.

THE means to be employed against the ravages of this insect in the more fertile country subject to its periodical visitations, but in which it is not indigenous, may be classed under five heads: 1, Encouragement of natural agencies; 2, Artificial means of destroying the eggs; 3, Artificial means of destroying the unfledged young; 4, Remedies against the mature or winged insects; 5, Prevention.

#### ENCOURAGEMENT OF NATURAL ENEMIES.

The natural enemies enumerated in Chapter VII should be encouraged as far as it is possible to encourage them. Man can do little to aid the multiplication of the more minute animals and parasites, but much to assist that of the larger animals, especially the birds mentioned. These should be protected by stringent laws, firmly carried out, restraining the wanton destruction in which sportsmen so often indulge. During the past few years, several of the "Western" States have passed good laws for the protection of our feathered friends, but the laws are often a dead-letter for want of enforcement.

#### DESTRUCTION OF THE EGGS.

The fact that man can accomplish most in his warfare against locusts by destroying the eggs has long been

recognized by European and Asiatic governments liable to suffer from the insects. The eggs, as we have seen, are laid in masses, just beneath the surface of the ground, seldom to a greater depth than an inch; and high, dry ground is preferred for the purpose. Very often the ground is so completely filled with these egg-masses, that not a spoonful of the soil can be turned up without exposing them, and a harrowing or shallow plowing will cause the surface to look quite whitish as the masses break up and bleach from exposure to the atmosphere. Great numbers will be destroyed by such harrowing or plowing, as thereby not only are they more liable to the attacks of natural enemies, but they lose vitality through the bleaching and desiccating influence of the dew and rain and sun. Wherever hogs and cattle can be turned into fields where the eggs abound, most of these will be destroyed by the rooting and tramping.

EXPERIMENTS WITH THE EGGS, AND CONCLUSIONS DRAWN THEREFROM.

There are many questions respecting the manner in which the eggs of this locust are affected under different conditions, which are of intense practical interest, and which are frequently discussed with no definite result being arrived at, and no positive conclusion drawn. Such are, for instance, the influence of temperature, moisture and dryness upon them; the effects of exposing them to the air, of breaking open the pods, of harrowing or plowing them under at different depths, of tramping upon them. Everything, in short, that may tend to destroy them or prevent the young locusts hatching, is of vital importance. With a view of settling some of these questions, and in the hope of reaching conclusions that might prove valuable, I carried on, during the past winter, a series of experiments, some

of which are herewith summed up. By reference to the meteorological table given on p. 152, the exact temperature at any of the dates mentioned, up to March 10, can be ascertained.

EXPERIMENTS TO TEST THE EFFECTS OF ALTERNATELY FREEZING AND THAWING.—The eggs in the following series of experiments were obtained early in November, at Manhattan, Kansas, under similar conditions. They were mostly in a fluid state at the time, and none but good and perfect masses were used. They were all carefully placed in the normal position at the surface of the ground, in boxes that could be easily removed from place to place. The experiments commenced November 10th, 1876, and ended in April, 1877. During November and December the weather was severe, while during January and February it was largely mild and genial for the season. In March again there was much frost.

The temperature in my office, into which all the eggs when not exposed were brought, ranged during the day from 65° to 70° F., rarely reaching to 75°. During the night it never dropped below 40°, and averaged about 55°.

*Experiment 1.*—Fifty egg-masses were exposed to frost from November 10th to January 10th, and then taken in-doors. In twenty days they commenced hatching, and continued to do so for thirty-eight days thereafter.

*Experiment 2.*—Fifty egg-masses exposed at the same time to frost. Brought in-doors on December 10th. On December 31st they commenced hatching numerously and continued to hatch till the 10th of January, 1877, when the remainder were exposed again. The weather being subsequently mild, some hatched on each warm day until the 26th. None hatched thereafter, and upon examination, subsequently, all were found to have hatched.

*Experiment 3.*—Fifty egg-masses exposed at same time. Brought in-doors December 1st. Kept there till the 22d without any of them

hatching. Exposed again for three weeks, and then brought in-doors on the 12th of January. They commenced hatching two days thereafter, and continued till the 29th. Subsequent examination showed them all to have hatched.

*Experiment 4.*—One hundred egg-pods exposed at the same time, but alternately brought in-doors and exposed again every fourteen days. Some commenced hatching during the second term in-doors; others continued during the warm days of the third exposure, and all had hatched by the sixth day of the third term in-doors.

*Experiment 5.*—A lot of one hundred egg-masses alternately exposed and brought in-doors every week. During the first four terms of exposure they were continuously frozen, while during the next four the weather was frequently mild enough to permit hatching. They first began to hatch during the fourth term in-doors, and continued to hatch, except during the colder days when exposed, until the seventh term in-doors, during which the last ones escaped.

*Experiment 6.*—Many hundred egg-masses kept out-doors the whole time, first commenced hatching March 2d, and continued for thirty-eight days thereafter.

*Experiment 7.*—Many hundred pods, kept in-doors till December 15th, and hatching from November 28th up to that time, were then exposed, and continued to hatch whenever the weather permitted, up to April 10th.

*Experiment 8.*—A lot of one hundred pods that had been hatching in-doors from November 19th, were exposed to frost January 15th, and brought in-doors again January 28th, where they continued hatching till February 10th. Every one was subsequently found to have hatched.

*Experiment 9.*—A lot of one hundred under same conditions as in Experiment 8, up to January 28th. They were then exposed again and brought in-doors February 16th, when they commenced hatching and continued to do so till the 27th. All were found subsequently to have hatched.

Two important conclusions are deducible from the above experiments :

*First*—The eggs are far less susceptible to alternate freezing and thawing than most of us, from analogy, have been inclined to believe. Those who have paid attention to the

subject, know full well that the large proportion of insects that hibernate on or in the ground, are more injuriously affected by a mild, alternately freezing and thawing winter, than by a steadily cold and severe one; and the idea has quite generally prevailed, that it was the same with regard to our locust eggs. But, if so, then it is more owing to the mechanical action which, by alternate expansion and contraction of the soil, heaves the pods and exposes them, than to the effects of the varying temperatures.

*Second*—That suspended development by frost may continue with impunity for varying periods, after the embryo is fully formed and the young insect is on the verge of hatching. Many persons, having in mind the well known fact that birds' eggs become addled if incubation ceases before completion, when once commenced, would, from analogy, come to the same conclusion with regard to the locust eggs. But analogy here is an unsafe guide. The eggs of insects hibernate in all stages of embryonic development, and many of them with the larva fully formed and complete within. The advanced development of the locust embryo, frequently noticed in the fall, argues nothing but very early hatching as soon as spring opens. Their vitality is unimpaired by frost.

EXPERIMENTS TO TEST THE INFLUENCE OF MOISTURE UPON THE EGGS.—The following series of experiments was made with eggs also brought from Manhattan, Kansas. They were dug up in December, and were sound, and much in the same condition as those in the preceding series.

The water in all but the last three, or Experiments 23, 24 and 25, was kept in my office at the temperature already stated, and changed only when there was the least tendency to become foul. In the alternate submergence and draining, the eggs were submitted to the most severe hygrometric

changes ; the warm atmosphere of the room having great drying power.

*Experiment 10.*—Ten egg-masses kept under water in-doors from December 5th to December 26th, 1876, the water becoming quite foul. They were then removed to earth and kept in a hatching temperature. They commenced hatching January 11th, 1877, and continued to do so till February 5th—all having hatched.

*Experiment 11.*—Twenty egg-masses kept under water in-doors from December 26th, 1876, till January 2d, 1877 ; then left dry till the 9th ; then submerged again till the 16th, when they were drained again. On the 20th, eighteen young hatched, and others continued hatching till the 23d, when they were submerged again. From the 26th to 30th, a few hatched under water, successfully getting rid of the post-natal pellicle, and living for some hours afterward in the water. On the 30th they were drained again, and continued to hatch. On February 6th, they were again immersed, and continued to hatch on the 7th. On the 15th, 22d, 29th, and March 7th, they were alternately drained and immersed ; but none hatched after February 7th, and the remainder proved upon examination to have been destroyed, most of them being quite rotten.

*Experiment 12.*—Two egg-masses taken from the lot in Experiment 11, on February 7th, and placed in moist earth. Every egg subsequently hatched.

*Experiment 13.*—Two egg-masses taken from the lot in Experiment 11, on February 22d, and placed in moist earth. All hatched.

*Experiment 14.*—Twenty egg-masses alternately immersed and drained every two weeks from December 26th till March 6th. None hatched, but three-fourths of the eggs were at this date sound, the embryo full-formed and active as soon as released, but pale, and evidently too feeble to burst the egg-shell. The rest were killed and more or less decomposed.

*Experiment 15.*—Two egg-masses, after immersion for two weeks, were placed in moist earth. They began hatching twenty-two days afterward, and continued to do so for six days. It was subsequently found that only seven out of forty-eight eggs had collapsed and failed to hatch.

*Experiment 16.*—Two egg-masses immersed for two weeks and drained for two weeks ; then placed in moist earth. Six days afterward they commenced hatching, and continued to do so for two

days. Subsequently examined, twenty-eight out of fifty-four eggs had perished.

*Experiment 17.*—Two egg-masses alternately immersed, drained, and immersed again every two weeks, were placed in moist earth. They commenced hatching two days afterward, and continued to do so for twelve days. Upon subsequent examination, twenty-three out of fifty-two had perished.

*Experiment 18.*—Twenty egg-masses immersed from Dec. 26th, 1876, to Jan. 16th, 1877; then drained till Feb. 6th; then immersed till Feb. 27th; then drained again. On Feb. 3d, while dry, they commenced hatching numerously, and a few continued for two days to hatch while immersed. An examination March 7th, showed about half of them still alive, the rest rotten. On March 27th they were drained again, but none subsequently hatched—all having rotted and dried up.

*Experiment 18a.*—Two masses in same conditions as in Expt. 18 till Feb. 27th, were placed in moist earth and all the eggs hatched March 7—12.

*Experiment 19.*—Twenty egg-masses immersed from Dec. 26th, 1876, to Jan. 23d, 1877; then drained till Feb. 20th; then submerged again. They commenced hatching on the 6th of Feb., and continued two days after the second submergence. On the 7th of March but about five per cent. had rotted. On March 20th they were drained again, but none subsequently hatched, except five eggs from two pods at once placed in earth.

*Experiment 20.*—Two egg-masses immersed for four weeks; then drained for two weeks; then immersed for one week; then placed in moist earth. They commenced hatching seven days afterward, and continued to do so for six days. Subsequently examined, one of the masses was rotten; the eggs in the other had all hatched.

*Experiment 21.*—Twenty egg-masses kept from Dec. 26th, 1876, in earth saturated with moisture. On Feb. 23d, 1877, they commenced hatching, and continued to do so till March 7th, when all were found to have hatched, except one pod, which was rotten.

*Experiment 22.*—Twenty egg-masses, alternately placed every five days, from Dec. 26th, 1876, in earth saturated with moisture and in earth which was very dry. Commenced hatching Feb. 14th, and continued till March 7th, when, upon examination, all had hatched, except nine of the pods, which were rotten.

*Experiment 23.*—Twenty egg-masses immersed and exposed

out-doors Dec. 26th, 1876. From that time till April 9th, the water was frozen and completely thawed at nine different times, the vessel containing them, which was of glass and admitted the sunlight, several times breaking. The changes were as follows: Frozen till Jan. 10th; then thawed till the 12th; then frozen till the 18th; then thawed till the 20th; then frozen till the 26th; then thawed till Feb. 20th; then partly frozen till the 22d; then thawed till the 26th; then frozen till the 27th; then thawed till March 5th; then frozen till March 10th; then thawed till March 15th; then frozen till the 16th; then thawed till the 24th; then frozen till the 25th. Examined on the 7th of March only one pod was found rotten; the others apparently sound. On the 9th of April, all with the exception of twelve eggs were found rotten, the masses having become disintegrated and the eggs for the most part lying singly at the bottom.

*Experiment 24.*—Two egg-masses under same conditions as in Expt. 23, till Feb. 9th, when they were brought in-doors and placed in earth. One was dried up on the 16th; the other commenced hatching on the 27th, and when examined on March 7th, all the eggs in it were found to have hatched.

*Experiment 25.*—Two egg-masses under same conditions as in Expt. 23, till Feb. 27th, when they were placed in earth in-doors. Examined March 7th, they were found sound, and near the hatching point. On March 20th they commenced hatching.

*Experiment 25a.*—Two egg-masses, under same conditions as in Expt. 23, up to March 6th, were then placed in earth in-doors. They commenced hatching March 23d, and continued till April 3d. Subsequently examined, but eight out of the fifty-four eggs were shrunken and dead.

*Experiment 25b.*—Two egg-masses under same conditions as in Expt. 23, up to March 27th, were then placed in earth, as above. April 14th—20th, ten hatched. Subsequently examined, the rest were found rotten.

*Experiment 25c.*—The twelve eggs remaining April 9th, from Expt. 23, were placed in earth. Five out of the twelve hatched April 20th—26th. The rest were subsequently found rotten.

These experiments establish a few facts that were somewhat unexpected. The insect is a denizen of the high and arid regions of the Northwest, and has often been observed to prefer dry and sunny places, and to avoid wet land, for



purposes of ovipositing. The belief that moisture was prejudicial to the eggs, has, for these reasons, very generally prevailed. The power which they exhibit of retaining vitality, and of hatching under water or in saturated ground, is, therefore, very remarkable—the more so when viewed in connection with the results obtained in the succeeding experiments. That the eggs should hatch after several weeks submergence, and that the young insect should even throw off the post-natal pellicle, was, to me, quite a surprise, and argues a most wonderful toughness and tenacity. After they had been dried and soaked for over six weeks, under conditions that approach those of spring, I found a good proportion of the eggs to contain the full-formed and living young, which, though somewhat shrunken, and evidently too weak to have made an exit, were still capable of motion. The water evidently retards hatching. An examination of the submerged eggs that remained unhatched long after others had hatched, which had been under similar treatment up to a certain time, and then transferred to earth, showed all the parts to be unusually soft and flaccid. Yet, when once life has gone, the egg would seem to rot quicker in the water than in the ground.

The results of Experiments 23—25c prove conclusively that water in winter time, when subject to be frozen, is still less injurious to the eggs.

Altogether, these experiments give us very little encouragement as to the use of water as a destructive agent; and we can readily understand how eggs may hatch out, as they have been known to do, in marshy soil, or soil too wet for the plow; or even from the bottom of ponds that were overflowed during the winter and spring. While a certain proportion of the eggs may be destroyed by alternately soaking and drying the soil at short-repeated inter-

vals, it is next to impossible to do this in practice during the winter season as effectually as it was done in the experiments; and the only case in which water can be profitably used is where the land can be flooded for a few days just at the period when the bulk of the eggs are hatching.

EXPERIMENTS TO TEST THE EFFECTS OF EXPOSURE TO THE FREE AIR.—The eggs in the following series were obtained at Manhattan, Kansas, in November, and all under similar conditions.

*Experiment 26.*—A large number of egg-masses were thoroughly broken up and the single eggs scattered over the surface of the ground out-doors early in December. By the 23d of February all had perished, and most of them had collapsed and shriveled.

*Experiment 27.*—A large number of pods were partly broken up and exposed as in Expt. 26. On the 10th of March the outer eggs were mostly dead and shrunken, but a few of the protected ones were yet plump, the embryo well advanced and apparently sound. Placed in earth they subsequently hatched.

*Experiment 28.*—A large number of unbroken pods were exposed under similar conditions as in the preceding Expts. By March 10th fully three-fourths of the eggs had perished, and by April 1st all had perished.

*Experiment 29.*—Fifty egg-masses were kept in-doors in an open-mouthed bottle in perfectly loose and dry earth from November 6th. Fully eight per cent. of the eggs had hatched by December 28th, when hatching ceased, and a subsequent examination showed the rest to have shrunken and perished.

It is very evident from the above experiments that we can do much more to destroy the eggs by bringing into requisition the universally utilizable air, than we can by the use of water. The breaking up of the mass and exposure of the individual eggs to the desiccating effects of the atmosphere, effectually destroys them; and when to

this is added the well known fact that thus exposed they are more liable to destruction by their numerous enemies, we see at once the importance of this mode of coping with the evil.

EXPERIMENTS TO TEST THE EFFECTS OF BURYING AT DIFFERENT DEPTHS, AND OF PRESSING THE SOIL.—The following series of experiments was made with eggs obtained at Manhattan, Kansas, early in November, and similar in condition to those in the first series. Large tin cylindrical boxes, made of different depths, and varying from four to eight inches in diameter, were used; and in order to hasten the result they were kept in-doors at the temperature already mentioned. The soil in all the boxes was finely comminuted and kept in uniform and moderately moist condition. It was gently pressed with the fingers, so as to approach in compactness the surface soil of a well cultivated garden. In each instance the eggs were placed in the center of the box. A large number of eggs were buried at different depths out-doors where they were under natural conditions of soil pressure and temperature. The soil was a tolerably stiff yellow clay, and was pretty well compacted by many heavy rains, after the frost was thawed out. The results of the out-door experiments comport with those made in the boxes. The eggs being placed at every depth from one to eighteen inches, and each batch covered with a wire screen, the result was accurately determined. All at one inch below the surface hatched; about one-third of those at two inches managed to escape, and none from any greater depth. Examined May 12th, they had hatched down to a depth of twelve inches, and worked their way upward, and horizontally, seldom extending more than one inch in the former, or more than two inches in the latter direction. Most of

those at greater depths were at that time unhatched. In looser soil, they would doubtless have managed to push somewhat farther.

*Experiment 30.*—Ten egg-masses were placed just one inch below the surface in the center of a box four inches in diameter. The young began to appear January 30th, when it was noticed that every one came up at the side of the box, between the earth and the tin, where there was more or less shrinking of the former from the latter. Upon pressing the earth more firmly around the border, the issuing of the young ceased. Upon examining the eggs, March 7th, it was found that they had all hatched. A few of the young were still alive, and endeavoring to escape; the rest had died in the effort. They had made no progress upward through the pressed surface, but had pushed horizontally as the looser earth permitted.

*Experiment 31.*—From ten egg-masses, placed two inches beneath the surface, the young commenced issuing from the sides, as in the preceding Expt., January 31st. None issued directly through the surface of the soil, and none issued after the border was pressed more firmly to the tin. Subsequent examination showed the soil penetrated in devious directions, but none of the insects had reached higher than within three-quarters of an inch of the surface.

*Experiment 32.*—Ten egg-masses placed three inches below the surface. The young began, January 31st, to issue from the sides, as in Expts. 30, 31. Upon pressing the ground more firmly around the borders, none afterwards issued, and subsequent examination showed that the young had tunneled the earth in tortuous passages toward the sides, and perished there; without reaching nearer than within an inch of the surface in the middle of the box.

*Experiment 33.*—Ten egg-masses placed six inches below the surface. On February 1st, the young commenced to issue, as in the preceding Expts., from the side, and continued to do so till the 4th, when the earth was pressed more closely to the tin. None issued afterwards. Subsequent examination showed that some had succeeded in working their way upward through the soil to within two inches of the surface; but most had reached the sides, and there collected and perished between the tin and the soil.

Other experiments made in glass tubes where the movements of the insects could be watched, all produced results

similar to those above given ; and all point to the conclusion that where the newly-hatched insect has not the natural channel of exit (described on p. 72) which was prepared by the mother, it must inevitably perish if the soil be moderately compact, unless cracks, fissures, or other channels reaching to the surface are at hand.

From the above four series of experiments, I would draw the following deductions, which have important practical bearing :

*First*—Frost has no injurious effect on the eggs ; its influence is beneficial rather, in weakening the outer shell.

*Second*—Alternate freezing and thawing is far less injurious to them than we have hitherto supposed, and tends to their destruction, if at all, indirectly, by exposing them to the free air.

*Third*—The breaking open of the egg-masses, and exposure of the eggs to the atmosphere, is the most effectual way of destroying them. Hence the importance of harrowing in the fall is obvious.

*Fourth*—Moisture has altogether less effect on the vitality of the eggs than has heretofore been supposed, and will be of little use as a destructive agent, except where land can be overflowed for two or three days at the time when the bulk of the young are hatching.

*Fifth*—Plowing under of the eggs will be effectual in destroying them, just in proportion as the ground is afterward harrowed and rolled. Its effects will also necessarily vary with the nature of the soil. Other things being equal, fall plowing will have the advantage over spring plowing, not only in retarding the hatching period, but in permitting the settling and compacting of the soil ; while where the ground is afterwards harrowed and rolled, the spring plowing will prove just as good, and on light soils perhaps better.

TEMPERATURE AT ST. LOUIS, MO., OF WINTER OF 1876-7.

1876.				1877.			
	Max	Min	Mean		Max.	Min.	Mean.
November 15.....	41	30	37	January 11.....	52	32	40
" 16.....	44	35	39	" 12.....	52	14	19
" 17.....	47	40	44	" 13.....	27	10	22
" 18.....	47	25	31	" 14.....	34	22	31
" 19.....	36	22	32	" 15.....	43	23	33
" 20.....	45	31	38	" 16.....	23	9	18
" 21.....	47	32	37	" 17.....	40	20	35
" 22.....	42	25	35	" 18.....	46	35	42
" 23.....	45	31	36	" 19.....	50	39	45
" 24.....	51	32	41	" 20.....	46	21	22
" 25.....	47	31	40	" 21.....	37	19	32
" 26.....	38	30	34	" 22.....	37	23	26
" 27.....	45	31	39	" 23.....	32	10	24
" 28.....	39	23	28	" 24.....	31	19	26
" 29.....	33	27	29	" 25.....	48	22	36
" 30.....	27	15	16	" 26.....	51	32	39
December 1.....	20	4	14	" 27.....	50	31	41
" 2.....	21	5	16	" 28.....	57	33	47
" 3.....	29	12	23	" 29.....	57	38	49
" 4.....	34	24	30	" 30.....	65	48	57
" 5.....	45	24	34	" 31.....	66	53	59
" 6.....	47	33	38	February 1.....	69	50	59
" 7.....	47	31	39	" 2.....	56	44	49
" 8.....	40	3	15	" 3.....	48	35	37
" 9.....	11	-5	5	" 4.....	46	32	39
" 10.....	37	9	31	" 5.....	40	28	33
" 11.....	55	28	44	" 6.....	49	34	41
" 12.....	60	36	48	" 7.....	53	38	46
" 13.....	50	38	42	" 8.....	47	36	42
" 14.....	38	18	27	" 9.....	50	33	44
" 15.....	45	12	36	" 10.....	58	37	52
" 16.....	44	4	12	" 11.....	58	42	52
" 17.....	27	13	20	" 12.....	52	29	32
" 18.....	22	2	16	" 13.....	36	28	33
" 19.....	37	18	28	" 14.....	44	30	38
" 20.....	43	23	33	" 15.....	53	31	44
" 21.....	43	23	34	" 16.....	47	38	40
" 22.....	37	20	26	" 17.....	50	34	42
" 23.....	24	13	19	" 18.....	66	34	53
" 24.....	19	11	15	" 19.....	58	34	37
" 25.....	21	13	18	" 20.....	48	27	39
" 26.....	21	13	19	" 21.....	65	34	51
" 27.....	24	15	21	" 22.....	53	44	47
" 28.....	26	17	21	" 23.....	44	33	38
" 29.....	19	10	14	" 24.....	35	29	32
" 30.....	21	4	15	" 25.....	33	28	31
" 31.....	34	17	24	" 26.....	43	28	37
				" 27.....	48	28	40
				" 28.....	50	32	43
1877.				March 1.....	47	39	48
January 1.....	24	13	14	" 2.....	47	37	39
" 2.....	8	15	15	" 3.....	49	18	29
" 3.....	26	11	21	" 4.....	22	14	26
" 4.....	42	19	33	" 5.....	40	26	34
" 5.....	42	29	36	" 6.....	55	30	46
" 6.....	43	32	37	" 7.....	57	26	47
" 7.....	35	18	21	" 8.....	55	18	28
" 8.....	13	-1	7	" 9.....	23	9	19
" 9.....	28	1	19	" 10.....	41	16	31
" 10.....	35	21	31				

## HARROWING IN FALL.

So satisfied have I been for some time that systematic harrowing of the eggs, or their exposure by other means, in the fall, is the best work that can be done, that I have earnestly urged its enforcement by law whenever the soil in any township is known to be well charged with eggs. A revolving harrow or cultivator will do excellent work, not only in the field, but in the road-ways and other uncultivated places, where the eggs may be laid. The more the soil is pulverized, after being broken up, the better.

## COLLECTING THE EGGS.

The eggs are sometimes placed where neither harrowing nor plowing can be employed. In such cases, they should be collected and destroyed by the inhabitants, and the State should offer some inducement in the way of bounty for such collection and destruction. Every bushel of eggs destroyed is equivalent to a hundred acres of corn saved, and when we consider the amount of destruction caused by the young, and that the ground is often known to be filled with eggs; that, in other words, the earth is sown with the seeds of future destruction, it is surprising that such bounty laws have not been more generally enacted. A few thousand dollars taken out of the State treasury for this purpose would be well spent, and be distributed among the very people most in need of assistance.

## PLOWING.

Plowing the eggs under deeply, destroys them either entirely or in great part, and if some survive, the young hatch so late the next season, that their power for harm is much lessened. Care should be taken not to bring the eggs turned under in autumn to the surface again, by plowing

the same land the following spring ; for, thus brought to the surface, the eggs more often hatch.

The experience as to deep plowing under of the eggs is somewhat conflicting, and in some light, dry soils, a good number of them will hatch late if turned under a foot ; yet, from my own observations, and a vast amount of experience gathered together, I recommend it as profitable. If delayed till spring, it should be done just as the young begin to hatch, as it is then most effectual. The plowing will be effectual according as the soil is porous or tenacious, *and according as the surface is afterward compressed by harrowing and rolling.* From the experiments already recorded, it is obvious that, all other things being equal, a plowing of four to six inches will prove more effectual in spring, if the ground be subsequently harrowed and rolled, than deeper plowing with no subsequent comminution and compression.

#### IRRIGATION — TRAMPING.

Where the ground is light and porous, excessive and continued moisture will cause most of the eggs to perish ; and irrigation, or alternate submersion and drying of such land, will likewise prove beneficial. It is less useful, however, than is generally supposed, and on tenacious soils will have little effect.

Wherever hogs or cattle can be turned into the fields where the eggs abound, most of these will be destroyed by the rooting and tramping. All these means are obviously insufficient, however, for the reason that the eggs are too often placed where none of them can be employed.

In such cases, they should be collected and destroyed by the inhabitants, and the bounty laws, presently to be considered, are useful in this connection.



## DESTRUCTION OF THE YOUNG OR UNFLEDGED LOCUSTS.

Next to the destruction of the eggs, the destruction of the young or unfledged locusts is most within man's power. The means of accomplishing this result necessarily vary somewhat with the nature of the soil and of the crops. For convenience, they may be classified into: 1, *burning*; 2, *crushing*; 3, *trapping*; 4, *catching*; 5, *the use of destructive agents*.

1. *Burning*.—In a prairie and wheat-growing country, like much of that which this locust devastates, and where there is always an abundance of old straw, burning is perhaps the best means of warfare against the young. These, for some time after they hatch, may be driven into windrows or heaps of straw scattered around and through a field, and burned. During cold, damp weather, they will, of their own accord, congregate under such shelter, and may sometimes be exterminated by burning, where no driving is necessary. As to burning the prairie in the spring, while there is much to be said *pro* and *con*, it is, all things considered, beneficial in this connection. Scarcely any eggs are laid in rank prairie, and the impression that locusts are slaughtered by myriads in burning extensive areas, is a false one. This practice is beneficial principally around cultivated fields and roadsides, from which the locusts may be driven, or from which they will of themselves pass for the shelter the prairie affords.

The burning of extensive prairies, after the bulk of the locusts hatch, destroys the nests and eggs of some game birds which feed upon the locusts, but the birds themselves always escape and nest again; whereas many noxious insects, like the chinch bug, are killed; so that, even leaving the locust question out of consideration, the burning would yet prove advantageous to man.

It is beneficial in proportion as it is delayed, because the locusts, as they develop, disperse more and more from their hatching grounds into the prairie.

In Colorado, machines for burning have been used to good advantage. Mr. J. Hetzel, of Longmont, uses a burner drawn by horses. It is twelve feet long, two to two and one-half feet wide, made of iron, and set on runners four inches high. An open grate on the top of the runners is filled with pitch-pine wood, and a metal sheet covers the grate to keep the heat down. The grate is generally made with a network of heavy wire, such as telegraph-wire. Two men and a team will burn ten to twelve acres a day, and kill two-thirds of the insects, but it requires a hot fire. Mr. C. C. Horner gives, in the *Colorado Farmer*, the following more detailed description of a machine which works on the same principle :

It consists of three runners made of 2x4 scantling three feet in length, to be placed six feet apart, making the machine twelve feet wide; runners to be bound together by three flat straps or bars of iron (the base being twelve feet long.) Across the top, bars of iron hold the runners firmly together, and form a frame across which wire can be worked, to make a grate to hold fire. The upper part of the runners should be hollowed out so that the grate may slide along within two inches of the ground. A sheet-iron arch should be set over this grate to drive the heat downward. This machine is very light, and can be worked with one horse. Pitch-wood is best adapted to burning, and can be chopped the right length and size and left in piles where most convenient when needed. This machine is intended to be used when the little hoppers just make their appearance along the edge of the grain, going over the ground once or twice each day, or as often as necessary to keep them killed off. The scorching does not kill the grain, but makes it a few days later. This is certainly the cheapest as well as the most effectual manner of getting rid of this pest.

A hand burner, consisting of any form of pan or grate, to hold combustible material, and attached to a handle, will do excellent service in gardens and small enclosures.

Long wire or iron rods, wrapped in rags saturated with

kerosene, and then ignited and carried over a field, near the ground, will slaughter large numbers.

2. *Crushing*.—This can be resorted to with advantage only in exceptional cases, where the ground is smooth and hard. Heavy rolling, where the surface of the soil is sufficiently firm and even, destroys a large number of the newly-hatched young, but is most advantageously employed when they are most sluggish and inclined to huddle together, as during the first eight or ten days after hatching, and in the mornings and evenings subsequently. In many parts of Europe and Asia, flat, wooden, spade-like implements are extensively used for this purpose.

3. *Trapping*.—This is very effectual, especially when the insects are making their way into a field from roads and hedge-sides. The use of nets or seines, or converging strips of calico or any other material, made after the plan of a quail-net, has proved most satisfactory. By digging a pit, or boring a post-auger hole three or four feet deep, and then staking the two wings so that they converge toward it, large numbers of the locusts may be driven into the pit after the dew is off the ground, or may be headed off when marching in a given direction. By changing the position of this trap, much good can be done when the insects are yet small and concentrated in particular spots.

Ditching or trenching will come under this head ; and after the insects have commenced to travel in schools, proper ditching is the most effectual protection to crops. This is especially true where, as was the case in much of the ravaged country in 1875, there is little or no hay or straw to burn ; or when the crops have grown to such a size as prevents the use of some of the destructive agents mentioned further on. A ditch two feet wide and two feet deep, with perpendicular sides, offers an effectual barrier to the young insects. It must, however, be kept in proper

order, so that the side next the field to be protected is not allowed to wash out or become too hard. It may be kept friable by brush or rake. They tumble into such a ditch and accumulate, and die at the bottom in large quantities. In a few days the stench becomes great, and necessitates the covering up of the mass. In order to keep the main ditch open, therefore, it is best to dig pits or deeper side ditches at short intervals, in which the hoppers will accumulate and may be buried. If a trench is made around a field about hatching time, but few hoppers will get into that field till they acquire wings, and by that time the principal danger is over, and the insects are fast disappearing. If any should hatch within the inclosure, they are easily driven into the ditches dug in different parts of the field. The direction of the apprehended approach of the insects being known from their hatching locality, ditching one or two sides next to such locality is generally sufficient, and when farmers join they can construct a long ditch which will protect many farms.

I have not a doubt but that with proper and systematic ditching early in the season, when the insects first hatch, nearly everything can be saved.

Just behind the fair-grounds at Kansas City, Mo., there is an intelligent and industrious gardener, Mr. F. D. Adkins, who, in 1875, had about three acres in vegetables. The locusts hatched in large numbers all around Kansas City, and nowhere more abundantly than in the immediate vicinity of this truck-garden. Mr. Adkins, remembering his experience with the same plague in 1867, persevered in ditching for their destruction in 1875; and though the surface of the country for miles and miles around was desolate, yet this little three-acre field was untouched—a perfect oasis in the desert, at once giving pleasure to the eye, and speaking eloquently of what may be accomplished

by a little tact and perseverance. Numerous other instances of this kind might be given. I have seen people driving off the young locusts day after day, in their endeavors to save some small vegetable or flower garden — their efforts eventually in vain — where one-tenth the time spent in ditching would have effectually accomplished the object. And when I should, perhaps, have been praying, I have witnessed sights that prompted to thought and word the very reverse of prayer. In a large portion of Johnson county, Mo., the injury in 1875 was slight, and until the end of May little damage was done around Warrensburg. Happening to be in the vicinity of this town on the 3d of June, I came upon a beautiful vineyard which had up to that time escaped. The insects had got into it, and the owner was advised to ditch to save it. His piety exceeded his good sense, however, and instead of genuflecting on a spade he was performing the operation in another way, while his beautiful vineyard was being destroyed at so speedy a rate that it would not show a green leaf by the morrow. I respect every man's faith, but there are instances where I would respect his work a good deal more.

Where the soil is tenacious, and water can be let into the ditches so as to cover the bottom, they may be made shallower, and still be effective. Mr. Frank Holsinger, of Kansas City, under date of May 23rd, 1875, sent me the following account of his experience:

Your very interesting communication to the *St. Louis Globe* was reproduced in our *Journal of Commerce* on the 21st inst. I have no doubt but that your counsel will be heeded by many, but to the mass of our people it is as "sounding brass," etc. During the past four days I have been at work, and although I spent less than one-fourth of my time to the purpose, I have destroyed between thirty and forty bushels of wingless locusts. My remedy is so simple I concluded to give it to you, as I think it better than any I have yet seen, and had I known how easy it was to accomplish I would now see growing crops where ruin and desolation appear.

As they had entered my wheat (I took your advice and fall-

plowed everything, and I do not think there was a hatful hatched on my forty acres) from neighboring farms, and knowing that when they got through they must move in force on my garden, I cautioned my wife to inform me when they commenced on this last. On the 18th inst., at 11 A. M., she gave the watch-word, "they come;" so, leaving corn-plowing, I hastened to surround our garden with a board fence, intending to drive the insects around, but to no purpose, although the boards were placed at 45° outward, and some six of us were at work. Still they came. We built straw fires next—still unsatisfactory. I had been underdraining, and had some drains still open. Wife said, "you will work yourself sick, and all to no purpose." I took a look, and a patch of early potatoes, one-third of an acre, which we had saved, was melting before them. I then saw them march straight for the drain. My impulse then was to burn them in the drain. This I found difficult. The next thought was "pit-falls at intervals in the drain." I commenced digging these, and the locusts tumbled in by thousands, but many escaped. Now the thought occurred that if there was water in the pits they *could not jump*; so water was thrown in, and the result was a success. I feel certain that by a judicious expenditure of \$50, in ditching around my thirty-five acres, I could have saved everything, while my loss is largely in excess of \$1,000.

The width and depth of the ditch is important, and as experience differed somewhat I have been at pains to get the experience of a large number of correspondents addressed by circular. Many have successfully used ditches two feet deep and eighteen inches wide; a few have made them only 18 in. x 18 in.; those who have used water found 12 in. x 15 in. sufficient, while the larger number used a ditch such as I have recommended, viz., two feet deep by two feet wide, with perpendicular sides. Having been the first to recommend proper ditching in this country, I have felt particular interest in its results, and have been in no small degree amused at the fault found with my recommendation, by those who, through slovenly-made ditches or other causes, have not been successful in this mode of warfare. It is less effectual against the newly-hatched young, which more easily crawl up a perpendicular bank than the larger ones, and its efficacy will vary with the nature of the soil and other circumstances; for, in proportion as the soil is loose, and ditches hence apt to fill up by the action of strong winds,

or in proportion as strong winds carry the insects over, ditching will necessarily fail.

Those who, from theory rather than from experience, are skeptical about the efficacy of ditching, urge that the locust, especially in the pupa state, can hop more than two feet. In truth, however, whether when traveling in a given direction of their own accord, or when being driven or disturbed, they very seldom leap that distance, as all who have had experience well know. That, on a pinch, the pupa can leap even farther, is true; but the fact remains that in practice, *Caloptenus spretus* seldom does. So the chinch bug, though capable of flight, will yet tumble into a ditch by myriads rather than use its wings. Even the larger winged *Acridia* and *Ædipodæ* tumble into such a ditch, and seldom get out again. I would remark in this connection, also, that a ditch three feet wide, unless correspondingly deep, will be more apt to permit the insects to escape, when once in, than a narrower one. In hopping, the more perpendicular the direction the insects must take, the shorter will be the distance reached.

The efficacy of the ditch depends not so much on the inability of the young locusts to jump or scale it, as on their tendency not to do so. In the bottom of the ditch they soon become demoralized, crippled and enfeebled, by constant effort, and the trampling and crowding upon one another.

4. *Catching*.—There are innumerable mechanical contrivances for this purpose. The cheapest and most satisfactory are those intended to bag the insects. A frame two feet high and of varying length, according as it is to be drawn by men or horses, with a bag of sheeting tapering behind and ending in a small bag or tube, say one foot in diameter and two or three feet long, with a fine wire door at the end to admit the light and permit the

dumping of the insects, will do admirable work. The insects gravitate toward the wire screen, and when the secondary bag is full they may be emptied into a pit dug for the purpose. These bagging-machines will prove most serviceable when grain is too high for the kerosene pans, presently to be described, and they will be rendered more effectual by having runners at distances of about every two feet extending a foot or so in front of the mouth, so as to more thoroughly disturb the insects and prevent them from getting underneath; also by being drawn by wings of vertical teeth so as to increase the scope with as little resistance to the wind as possible.

Hand nets, such as are used by entomologists, and which

[Fig. 34.]

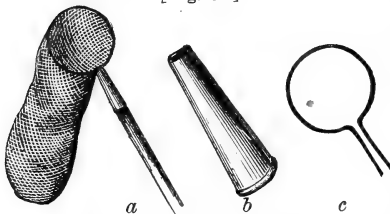

HAND NET:—*a*, complete: *b*, hollow handle: *c*, bent frame.

are easily made as shown in accompanying figure, will do good service in gardens.

A curious suction-fanning machine has been invented by Mr. J. C. King, of Boulder, Col., and may be mentioned in this connection. A strong draft sucks the insects up through an elongate mouth with lips that run near the ground, and draws them up through two funnels and knocks them to pieces. I have seen the working of such a machine in Mr. T. C. Henry's possession at Abilene, Kan. It is an admirable invention, and may be improved so as to be of great service; but on account of its expense will scarcely compete with the more simple methods.

5. *Use of destructive agents.*—Kerosene is the most effective. It may be used in any of its cruder forms. In Colorado they use it to good advantage on the water in their irrigating-ditches, and it may be used anywhere in



pans or in saturated cloths, stretched on frames, drawn over a field. A good and cheap pan is made of ordinary sheet-iron, eight feet long, eleven inches wide at the bottom, and turned up a foot high at the back and an inch high at the front. A runner at each end, extending some distance behind, and a cord attached to each front corner, complete the pan, at a cost of about \$1.50.

[Fig. 35.]

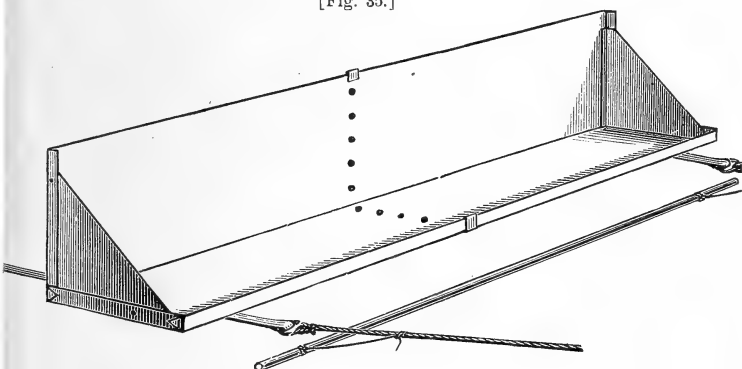

SMALL COAL-OIL PAN.

I have known from seven to ten bushels of young locusts caught with one such pan in an afternoon. It is easily pulled by two boys, and by running several together in a row, one boy to each outer rope and one to each contiguous pair, the best work is performed with the least labor. Heavier or longer pans, to be drawn by horses, should have transverse partitions to avoid spilling the liquid; also more runners. The oil may be used alone so as to just cover the bottom, or on the surface of water, and the insects strained through a wire ladle. When the insects are very small, one may economize in kerosene by lining the pan with saturated cloth; but this becomes less efficient afterwards, and frames of cloth saturated with oil do not equal the pans.

Where oil has been scarce, some persons have substituted concentrated lye, but when used strong enough to kill, it costs about as much as the oil. The oil-pans can be used only when the crops to be protected are small.

Small pans for oil, attached to an obliquing pole or handle, do excellent service in gardens.

[Fig. 36.]

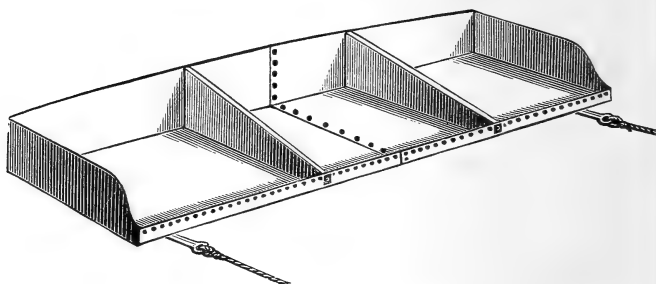

LARGE COAL-OIL PAN.

Coal tar may also be used to good advantage in similar pans, either drawn or pushed by man or horse.

Mr. Rufus Clark, of Denver, uses a piece of oil cloth, nine to twelve feet long, and six feet wide; one side and each end are secured to light wooden strips by common carpet tacks, and the corners strengthened by braces.

“The oil cloth is smeared with coal tar, purchased at the Denver Gas Works for \$7.50 per barrel, and the trap is dragged over the ground by two men—a cord about ten feet long being fastened to the front corners for that purpose. The entire expense of the “trap” is about \$3.50, and as it is light and easily handled, will be found serviceable on small as well as large farms.”

Zinc instead of oil cloth has also been used for the same purpose.

The experience of 1875 showed that when the insects

are famishing, it is useless to try and protect plants by any application whatever. Sweetened water, which was supposed to be effective, certainly has no such effect on the unfledged hoppers, for they, "went for" plants which I thus sprinkled even more voraciously than for those not sprinkled. Lime does not deter them; cresylic soap will not keep them from eating; and Paris green, though it undoubtedly kills those which partake, is yet no protection to plants, because those which go off to die somewhere after partaking are continuously followed by others which go through the same experience. I gave carbonic acid gas, from a Babcock fire extinguisher, a thorough trial under many different circumstances and conditions, but without any satisfactory results. It had very little effect upon them even when played upon them continuously and at short distance. They often became numbed by the force of the liquid but invariably rallied again.

A mixture of kerosene and warm water, applied through an atomizer or spraying machine, is, perhaps, the best protection, and will measurably keep the insects off when they are not too numerous.

Paris green, mixed with flour, in proportion of one part of green to twenty-five or thirty parts of the diluent, if scattered on the ground, will attract quite a number of the insects, which will eat thereof and die. This mixture has long been known to kill the Colorado Potato-beetle. Its use against the young locusts is, however, practically of little avail, first on account of their numbers, secondly on account of the danger incident to the use of so poisonous a remedy.

#### PROTECTION OF FRUIT TREES.

The best means of protecting fruit and shade trees deserves separate consideration. Where the trunk is smooth

and perpendicular, they may be protected by whitewashing. The lime crumbles under the feet of the insects as they attempt to climb, and prevents their getting up. By their persistent efforts, however, they gradually tear off the lime and reach a higher point each day, so that the whitewashing must be often repeated. Trees with short, rough trunks, or which lean, are not very well protected in this way. A strip of smooth, bright tin answers even better for the same purpose. Encircling the tree in any of the different ways employed for preventing the ascension of the female Canker Worm, puts an effectual estoppel on the operations of the young locusts above the point of attachment, for they can not jump from and alight again on the same perpendicular surface. A strip of tin three or four inches wide, brought around and tacked to a smooth tree, will protect it ; while on rougher trees a piece of old rope may first be tacked around the tree, and the tin tacked to it so as to leave a portion both above and below. Passages between the tin and the rope, or the rope and tree, can then be blocked by filling the upper area between tin and tree with earth. The tin must be high enough from the ground to prevent the hoppers from jumping from the latter beyond it ; and the trunk below the tin, where the insects collect, should be covered with coal tar or some poisonous substance, to prevent girdling. This is more especially necessary with small trees.

One of the cheapest and simplest modes is to encircle the tree with cotton batting, in which the insects will entangle their feet, and thus be more or less obstructed. Strips of paper covered with tar, stiff paper tied on so as to slope roof-fashion, strips of glazed wall-paper, and thick coatings of soft soap, have been used with varying success, but no estoppel equals the bright tin. The others require constant watching and renewal, and in all cases coming

under my observation, some insects would get into the trees, so as to require the daily shaking of these, morning and evening. This will sometimes have to be done, when the bulk of the insects have become fledged, even where tin is used, for a certain proportion of the insects will then fly into the trees. They do most damage during the night, and care should be had that the trees be unloaded of their voracious freight just before dark.

Most cultivated plants may be measurably protected from the ravages of these young by good cultivation and a constant stirring of the soil. The young have an antipathy to a loose and friable surface, which incommodes them and hinders their progress, and they will often leave such a surface for one more hard and firm.

Finally, though insisting on ditching and the digging of pits as, all things considered, the best and most reliable insurance against the ravages of the young locusts, I would urge our farmers not to rely on these means alone, but to employ all the other means recommended, according as convenience and opportunity suggest.

One of my correspondents, Capt. John R. Wherry, of Boonville, Mo., has suggested the use of strips of canvas, dipped in liquid sulphur and attached to stakes to be stuck in the ground. He thinks that if the strips are lit at evening the fumes will drive the insects away from the locality they pervade. The suggestion strikes me quite favorably as a means of protecting orchards, and I would recommend its trial. The strips should be dipped in hot sulphur, allowed to cool, and then staked to the windward of the orchard, if the wind is stirring.

#### DESTRUCTION OF THE WINGED INSECTS.

The complete destruction of the winged insects, when they swoop down upon a country in prodigious swarms, is

impossible. Man is powerless before the mighty host. Special plants, or small tracts of vegetation may be saved by perseveringly driving the insects off, or keeping them off by means of smudges, as the locusts avoid smoke; or by rattling or tinkling noises constantly kept up. Long ropes perseveringly dragged over a grain field, have been used to good advantage. Great numbers may be caught and destroyed by bagging and crushing, as recommended for the new-fledged; and I would more particularly urge their destruction in this way late in the season, when, early and late in the day, they are comparatively sluggish: but as a rule, the vast swarms from the West or Northwest will have everything their own way. In the latitude of St. Louis, these invading swarms usually come too late to affect the small grains, or to materially affect corn; but farther north they are more to be dreaded, and the experience of Minnesota and Dakota farmers teaches that one of the best ways of avoiding their injuries is to grow such crops as will mature early.

Mr. S. T. Kelsey succeeded in saving many of his young forest trees in Kansas, in 1874, by perseveringly smudging and smoking them.

He gives his experience in the following words, in the *Kansas Farmer*, Aug. 26, 1874:

At first we tried building fires on the ground, but it was not successful. The smoke would not go where we wanted it to. We then tried taking a bunch of hay and, holding it between sticks, would fire it, and then, passing through the field on the windward side, would hold it so that the smoke would strike the grasshoppers. We would soon have a cloud of hoppers on the wing, and by following it up would, in a short time, clear the field. We have thus far saved everything that was not destroyed when we commenced fighting them; and while I do not give this as an infallible remedy, not having tried it sufficiently, yet it does seem to me, from what I have seen of it, that one good active man who would attend right to it, could protect a twenty-acre field or a large orchard. But to be successful, one must attend right to the business.

## PREVENTIVE MEASURES.

The measures so far recommended have in view the destruction of the insects when once they are upon us. The question very naturally arises, "Can not something be done to prevent the incursions of the species into the more fertile States in which it is not indigenous?"

The most important results are likely to flow from a thorough study of the Rocky Mountain Locust in its native haunts and breeding places, such as the U. S. Entomological Commission is now engaged in. By learning just when and how to strike the insect, so as to prevent, if possible, its undue multiplication there—whether by some more extensive system of irrigation, based on improved knowledge of the topography and water supply of the country, or by other means of destroying the eggs—we may hope to protect the fertile States to the East from future calamity.

One of the best means of checking the increase of the species in its native haunts, will be found in the encouragement and increase of its natural enemies, especially the game birds. The introduction of the English sparrow has been recommended. From what I know of the bird, both here and in its native country, I should expect little aid from it in this line, and if it can thrive to the Northwest, it will soon spread there, as it is rapidly multiplying at several points along the Mississippi. We may expect more good from the encouragement of native locust-feeding species. Prof. Thomas has suggested that inducements be offered to the Indians to collect and destroy the eggs and young along the west side of the plains. Some system of preventing the extensive prairie fires in fall that are common in the country where the insect naturally breeds, and then subsequently firing the country in the

spring, after the young hatch, and before the new grass gets too rank, might also be adopted. But whatever the means employed, they must be carried on systematically, and on a sufficiently extended and comprehensive scale.

#### SUGGESTIONS THAT MAY BE OF SERVICE.

In addition to the foregoing remedial and preventive measures to be taken in dealing with locusts, a few other suggestions occur, which may be of advantage. The plants that can be grown, which are unmolested by the pests, and which will not, in all likelihood, suffer, have already been enumerated. Those which are cultivated are principally peas and other leguminous species, castor beans, sorghum, broom-corn, tomatoes, sweet potatoes, etc. The locusts, as already stated, are particularly fond of tansy, cocklebur, and *Amarantus*: these weeds, where abundant, might be periodically sprinkled with Paris Green water or powder, so as to kill large numbers of the young insects. These last will also congregate on timothy in preference to other grasses or grain, and a strip of timothy around a corn or wheat-field, to be poisoned in the same way, might save the latter. It is also currently supposed that the common larkspur (*Delphinium*) is poisonous to these insects, but how much truth there is in the statement I am unable to tell. In going through an oat-field, the winged insects drop a great deal of the grain, which, when ripe enough, might at once be harrowed in so as to furnish a good growth of fodder that can be cut and cured for winter use. The lesson of 1873 and 1874 should also not go unheeded. The former year was one of plenty, and corn was so cheap and abundant that it was burned for fuel in many sections where, in 1874, there were empty cribs, and the farmers wished they had been more provident.



Nothing, however, will so surely insure those States subject to them, against the ravages of this insect, as irrigation. With water at command, the farmer in all this locust area is measurably master of his two greatest insect plagues, the Chinch bug and the Locust, and full master of the young locusts, either by inundating the land and drowning them out after hatching, or by using kerosene in the ditches; and if there were no other reasons to be urged in its favor, these are sufficient to warrant those States included in said area in using all means in their power in having schemes for irrigation perfected and carried out, so far as the topography, soil, and other peculiarities of the country will admit.

Hogs and poultry of every description delight to feed on the young hoppers, and will flourish where these abound, when nothing else does. It will be well, in the event of a future invasion, for the people in the invaded districts to provide themselves with as large a quantity as possible of this stock. Where no general and systematic efforts have been made to destroy either the eggs or the young locusts, and it is found that, as spring opens, these young hatch out in threatening numbers, the intelligent farmer will delay the planting of everything that can not be protected by ditching, until the very last moment, or till toward the end of June—using his team and time solely in the preparation of his land. In this way not only will he save his seed and the labor of planting, and, perhaps, replanting, but he will materially assist in weakening the devouring armies. Men planted in 1875, and worked with a will and energy born of necessity, only to see their crops finally taken, their seed gone, and their teams and themselves worn out. The locusts ultimately destroyed every green thing, until, finding nothing more, they began to fall upon each other and to perish. This

critical period in their history would have been brought about much earlier if they had not had the cultivated crops to feed upon ; and if, by concert of action, this system of non-planting could at first have been adopted over large areas, the insects would have been much sooner starved out and obliged to congregate in the pastures, prairies and timber. Moreover, the time required for early planting and cultivation, if devoted to destroying the insects after the bulk of them hatch out, toward the end of April, would virtually annihilate them. The multiplication of any species of animal beyond the power of the country to support it, inevitably proves the destruction of that species, unless it is able to migrate. Let fifty batches of canker-worm eggs hatch out on a single, somewhat isolated apple tree, and not one worm will survive long enough to mature. The leaves of the tree will be devoured before the worms are half grown, and the latter must then inevitably perish ; whereas, if only a dozen batches of eggs had hatched on that tree, the worms might all have lived and matured. In the same way, the young locusts inevitably perish whenever they are so numerous as to devour every green thing before they become fledged ; and in certain circumstances, the sooner such a condition of things is brought about, the better. The greatest generals and the mightiest armies must yield to starvation.

Grain might also be sown in "lands" or strips, fifty to one hundred feet wide, to permit of ditching between them, and those who have fall wheat up and doing well, where the eggs are thickly laid, should make ditches at intervals through the field, to facilitate the saving of the grain in the spring.

In this connection it is also very obvious that our Signal Service might be made the means of giving important

assistance to the farmers of the West, by warning them of coming danger. If, as I believe, the disastrous swarms which reach the southeastern country come from the extreme Northwest, there is no reason why, by increasing the number of signal stations in that region, the movements of large swarms should not be daily recorded, and the farmers to the East and Southeast be apprised of their probable coming for weeks in advance. The people might not, it is true, greatly benefit by the information, except in preparing and providing for the possible contingency; but by thus recording the movements of swarms, we shall in a few years come to know more about the native breeding places and habits of the species, and as the Bureau perfects its work, we may, through it, learn the fall before, when the insects have become unduly multiplied, or have laid enormous quantities of eggs, over large areas in their native habitat, and when, in consequence, an invasion the following year is probable; in which event a larger proportion of small grains and other crops that escape the ravages of the fall swarms, can be planted in the threatened country.

As to the best means of disposing of the slaughtered locusts, the easiest and most generally employed are burning and burying. Yet the insects might be turned to good advantage as manure, or sun-dried and preserved in cakes to feed to hogs, poultry, etc., and where large quantities are destroyed under a bounty system, some such means of making the most of them should be considered.

As a means of assisting farmers in the destruction of the unfledged locusts by trenches and in other ways, I would also urge the employment of the military, a large force of whom, in times of peace, could be ordered to the field at short notice. As I have elsewhere remarked:\* "To many, the

---

\* Proc. Am. Ass. Adv. Sc., 1875. B. 219.

idea of employing soldiers to assist the agriculturist in battling with this pest, may seem farcical enough, but though the men might not find glory in the fight, the war—unlike most other wars—would be fraught only with good consequences to mankind. In Algeria the custom prevails of sending the soldiers against these insects. While in the south of France last summer [1875], I found to my great satisfaction, that at Arles, Bouche du Rhône, where the unfledged locusts (*Caloptenus Italicus*, a species closely allied to our Rocky Mountain Locust), were doing great harm, the soldiers had been sent in force to do battle with them, and were then and there waging a vigorous war against the tiny foe." A few regiments, armed with no more deadly weapons than the common spade, sent out to sections of country that are suffering from locust ravages, might in a few weeks measurably rout the pygmean army, and materially assist the farmer in his ditching operations.

#### DIVERSIFIED AGRICULTURE.

Finally, much can be done to avert the evil we are considering by a judicious choice of crops. There is nothing surer than that the destitution in Western Missouri and Eastern Kansas, in 1874-5, was fully as much owing to the previous ravages of the Chinch bug as to those of this locust. The Chinch bug is an annual and increasing trouble; the locust only a periodical one. Now, the regions indicated, agriculturally, are the richest in those two States, and, for that matter, can scarcely be surpassed in the entire country. Consisting of high, rolling prairie, interspersed, as a rule, with an abundance of good timber, this area produces a very large amount of corn and stock. Of cultivated crops, corn is the staple, and, with a most generous soil, it has become the fashion to plant and cultivate little else, year after year, on the same ground. The

corn fields alternate more or less with pastures, and there is just enough small grain to breed and nourish the first brood of chinch bugs which pass into the corn at harvest time and which scatter over the country, by breeding and harboring in the corn fields. Not to mention the different means to be employed in counteracting the ravages of this insect, a diversified agriculture is undoubtedly one of the most effectual. It must necessarily follow that the more extensively any given crop is cultivated to the exclusion of other crops the more will the peculiar insects which depredate upon it become unduly and injuriously abundant. The Chinch bug is confined in its depredations to the grasses and cereals. Alternate your timothy, wheat, barley, corn, etc., upon which it flourishes, with any of the numerous crops on which it can not flourish, and you very materially affect its power for harm. A crop of corn or wheat grown on a piece of land entirely free from chinch bugs will not suffer to the same extent as a crop grown on land where the insects have been breeding and harboring. This fact is becoming partially recognized, and already hemp, flax and castor beans are to some extent cultivated in the States mentioned. But there are many other valuable root and forage plants that may yet be introduced and grown as field crops.

Of root crops that would escape the ravages of the winged locusts, and which would grow in ordinary seasons, and furnish excellent food for stock, may be mentioned turnips, ruta bagas, mangel wurzel, carrots (especially the large Belgian), parsnips and beets. Of tubers that are not so profitable but of which it would be well to plant small quantities in locust districts, for the reason, as my friend A. S. Fuller, of New York, suggests, that they grow with such ease, and are less likely to be injured by the insects, the Chinese Yam, Jerusalem Artichoke (*Helianthus tube-*

rosus), and the Chufa (*Cyperus esculentus*) are worthy of trial. Turnips, of which the insects are especially fond, kohlrabi, carrots, and the like, may be saved when they come late, by cutting off the tops and covering the roots with earth—the tops making excellent food for milch cows. The earth should be removed again as soon as possible to prevent the rotting of the roots.

#### LEGISLATION.

Too much stress can not be laid on the advantage of co-operation and concert of action, and legislation both to induce and to oblige action is important. In every community there are those who persist in doing nothing to prevent locust injury. These indifferents frequently bring ruin not only upon themselves, but upon more persevering neighbors, and any law will prove beneficial that will oblige every able-bodied man to work one or more days, either in the fall in destroying the eggs, or in the spring in killing the young insects, whenever the township trustees, at the request of a given number of citizens of the township, may call them to such work under special provisions similar to those of existing road laws.

It is a gratifying indication of the increasing appreciation of economic entomology that, while three years ago the mere suggestion to enact laws for the suppression of injurious insects would have been, and was, received by our legislators with ridicule; yet, during the winter of 1876-7, several States have seen fit to pass acts that have for object the destruction of this locust, or the relief of the suffering and destitution it so often entails—not to mention the appropriation made by Congress for a special investigation. The following are the State laws that have been passed:

MISSOURI.—AN ACT TO ENCOURAGE THE DESTRUCTION OF GRASSHOPPERS.

Be it enacted by the General Assembly of the State of Missouri, as follows :

SECTION 1. Any person who shall gather, or cause to be gathered by any person in his employ, eggs of the Rocky Mountain locust or grasshopper, at any time after they are deposited in the earth in the autumn of any year, and before they are hatched the following spring, shall be entitled to a bounty of five dollars for each and every bushel of eggs thus gathered, or for any quantity less than one bushel, bounty at the same rate, to be paid, one-half by the State and one-half by the county in which they are gathered.

SEC. 2. Any person who shall gather, collect and kill, or cause to be so collected and killed, young and unfledged grasshoppers in the month of March, shall be entitled to a bounty of one dollar for each bushel, and for the month of April, fifty cents per bushel, and for the month of May, twenty-five cents per bushel, to be paid in the same manner as in the preceding section.

SEC. 3. Any person claiming bounty under this act, shall produce the eggs and grasshoppers thus gathered or killed, as the case may be, before the clerk of the county court in which such eggs or grasshoppers were gathered or killed, within ten days thereafter, whereupon said clerk shall administer to such person the following oath or affirmation: You do solemnly swear (or affirm, as the case may be,) that the eggs (or grasshoppers, as the case may be,) produced by you, were taken and gathered by you, or by person or persons in your employ, or under your control, and within this county and State.

SEC. 4. The clerk shall forthwith destroy said eggs by burning the same and give to the person proving up the same under his hand and seal, a certificate setting forth in a plain handwriting, without interlineation, the amount of eggs or grasshoppers produced and destroyed by him, and the name and residence of such person producing the same, which certificate shall be in the following form:

STATE OF MISSOURI, }  
COUNTY OF..... }

This is to certify that.....in the county of.....A. B. did this day prove before me that he had gathered, or caused to be gathered, .....of eggs, .....grasshoppers, and is entitled to the sum of.....dollars, and.....cents.

Given under my hand and seal of my office, this .....day of.....A. D. 18...

.....A. B., Clerk County Court.

Which certificate shall be received and taken by the collector of revenue of the county in which the same was given, and such

- collector shall be allowed pay out of the county and State Treasury, one-half from each.

SEC. 5. Such clerk shall keep a register of all such certificates given by him, in a book which he shall keep for that purpose, in which he shall note down every certificate granted by him, the number and amount, and to whom granted, and transmit a certified copy of such register, under the seal of the court, to the Treasurer of the State, who shall not allow and pay any certificate, which does not correspond with such register.

SEC. 6. Such clerk shall receive for his services as aforesaid, one dollar for such certified copy of the register, and the regular fee for the certificate and seal, and ten cents for each certificate granted under this act, all to be paid out of the treasury of his county.

SEC. 7. As the object of this act is the rapid destruction of the locust the ensuing spring, it shall take effect and be in force from and after its passage.

Approved February 23, 1877.

This act is drawn up after the form recommended in my 8th Report, and reprinted in the Omaha pamphlet. Section 3, requiring persons claiming bounty, to carry from all parts of the county, the eggs or young insects collected, is defective, as those living near the county seat will have most advantage and inducement. It would be better to empower the Township Trustee, or the Street Commissioner, to receive and measure the eggs or young insects, and to issue certificates setting forth the number of bushels destroyed—the certificates to be filed with the County Clerk.

KANSAS—AN ACT TO PROVIDE FOR THE DESTRUCTION OF GRASSHOPPERS AND TO PUNISH FOR VIOLATION OF THIS ACT.

*Be it enacted by the Legislature of the State of Kansas:*

SECTION 1. That the township trustees of the different townships, and the mayors of cities which are not included in any township of any county within this State, are hereby authorized and it is made their duty, when so requested, in writing, by fifteen of the legal voters of the township or city, to issue orders to the road overseers of the different road districts within their respective townships or cities, to warn out all able-bodied males between the ages of twelve and fifty years within their respective districts for the purpose of destroying locusts or migratory insects.

SEC. 2. It shall be the duty of road overseers, immediately after receiving said orders, to proceed at once to warn out all persons liable under section one of this act, giving notice of the time and



place of meeting, and the tools to be used, and the kind of work expected to be performed, and all work shall be done and performed under the direction of the road overseers.

SEC. 3. Any persons over eighteen years of age warned out as is provided in this act, may pay the road overseer the sum of one dollar per day for the time so warned out, and in case any persons shall fail to perform labor under this act or paying the sum of one dollar when so warned out, shall be adjudged guilty of a misdemeanor, and on conviction, shall be fined the sum of three dollars for each day so failing or refusing, and the moneys so collected shall be expended by the road overseers in the destruction of grasshoppers in their respective road districts.

SEC. 4. For the purpose of carrying out the provisions of this act the road overseer is authorized to enter upon the premises of any person lying within the township where such order of the township trustee is in force, with a sufficient number of hands and teams to perform such labor as he may deem necessary for the public good.

SEC. 5. It shall be the duty of the Secretary of the State Board of Agriculture, immediately after the passage of this act, to compile in circular form all information relating to the manner and means heretofore used for the extermination of grasshoppers, and send at least ten copies of the same to each township trustee in the State.

SEC. 6. This act shall take effect and be in force from and after its publication once in the *Commonwealth*.

Approved March 6, 1877.

AN ACT PROVIDING FOR A CONCERT OF ACTION BY SENATORIAL DISTRICTS FOR THE DESTRUCTION OF GRASSHOPPERS.

*Be it enacted by the Legislature of the State of Kansas :*

SECTION 1. That in any senatorial district in the State of Kansas, where trouble is anticipated from the ravages of young grasshoppers, in the year 1877, and any subsequent year thereafter, it shall be lawful for the counties in said senatorial district to cooperate together in the way and manner herein provided, for the destruction of the same.

SEC. 2. The chairman of the board of county commissioners in the county having the largest number of inhabitants in a senatorial district, where two or more counties form said district, may notify the chairman of each of the boards of county commissioners of the remaining counties in said district, of the time and place when the chairmen of the several boards of commissioners of the respective counties forming said senatorial district shall hold a joint meeting.

SEC. 3. At such meeting two of their number shall be chosen to act as chairman and secretary, and the proceedings of the meeting shall be published in all the newspapers printed in the senatorial district.

SEC. 4. Said meeting shall designate the manner of procedure

by road overseers, and what day or days the young grasshoppers should be driven from the cultivated land on the unburnt prairie or places of destruction, and shall also designate on what day or days the grasshoppers shall be destroyed, by burning or otherwise, in said senatorial district, giving at least ten days' notice of the same by publishing in the newspapers of the said district.

SEC. 5. The board of commissioners of each county shall notify the road overseers of said county of the time fixed upon by the joint meeting for the driving and burning, or destroying by other means, of the grasshoppers in the district; said notice to be given to said overseers as soon as practicable after the same shall have been determined by the joint meeting.

SEC. 6. Said road overseers shall immediately notify the residents of his road district of the time designated and the manner of procedure, in order to carry out the provisions of this act. He shall also specify what tools or implements will be required of each resident in performing the labor required of him; and such notice may be enforced the same as in the acts authorizing road overseers to warn out the residents to perform road labor; and a refusal shall subject such persons refusing to the same penalties as are provided by law in such cases.

SEC. 7. The road overseers shall direct the manner of performing the labor, and have the supervision of the same, and shall keep a list of the names of those who shall perform labor, and shall certify the number of days' work performed by each, and shall place such certified list in the possession of the board of county commissioners of his county.

SEC. 8. It shall be lawful for two or more senatorial districts to co-operate together under the provisions of this act, on a basis of action which they may agree upon.

SEC. 9. This act shall take effect and be in force from and after its publication in the daily *Commonwealth*.

Approved March 7, 1877.

Both these acts look to compulsory work and concert of action, and in these respects are preferable to bounty acts, and will, without doubt, be productive of more good to the community at less expense to the State. The objects of the two acts should, I think, have been combined in one.

MINNESOTA—AN ACT TO PROVIDE FOR THE DESTRUCTION OF GRASSHOPPERS AND THEIR EGGS.

*Be it enacted by the Legislature of the State of Minnesota:*

SECTION 1. There shall be paid by this State, out of any moneys in the treasury thereof, not otherwise appropriated, to any person

or persons living within any of the counties in said State afflicted by grasshoppers, the following bounties for catching and destroying of the same, and the destruction of their eggs.

SEC. 2. The sum of one dollar per bushel for grasshoppers caught previous to the twenty-fifth day of May next. The sum of fifty cents per bushel from the said twenty-fifth day of May to the tenth day of June. The sum of twenty-five cents per bushel from the said tenth day of June to the first day of July, and twenty cents per bushel from the said first day of July to the first day of October next.

SEC. 3. There shall also be paid in the same manner, the sum of fifty cents per gallon for any and all grasshopper eggs taken and destroyed by any person or persons.

SEC. 4. There shall be appointed by the Governor a competent person in each township in the several counties so afflicted by grasshoppers, who shall be a resident of the township for which he shall be appointed, to receive, measure and destroy the grasshoppers and their eggs delivered to him by any person or persons catching and taking the same, which said person so appointed shall take and subscribe an oath for the faithful discharge of his duties, which oath, together with the certificate of appointment, shall be filed in the office of the county auditor, and he shall receive as compensation for his services such sum as the county commissioner may determine, to be paid out of the funds of the county; and in case of necessity, when he can not perform the duties of his office, said measurer shall have authority and be empowered to appoint a suitable and competent person his assistant, which assistant shall be required to take and subscribe the same oath and be subject to the same penalties as the said measurer.

SEC. 5. The person receiving and measuring the grasshoppers and their eggs as aforesaid, shall measure and immediately and effectually destroy the same, and keep an exact account of all the grasshoppers and their eggs received by him and the names of the persons delivering the same, and shall issue a certificate for the amount of grasshoppers and their eggs to the person delivering the same. And he shall, at the end of each week after commencing to receive and measure the same, and on the second day of June, on the eleventh day of said month, on the second day of July, and on the second day of October next, make a report to the county auditor of all the grasshoppers and their eggs measured by him, the number of certificates issued, and the names of the persons to whom he issued the same; and the county auditor shall examine the same and file it in his office, which report shall be subject to public inspection; and the county auditor shall, at the end of each week after he shall have received the first of said reports, transmit a copy of the said reports to the Governor, who shall, as soon as the sum hereby appropriated shall have been expended in the payment of said bounties, notify all persons interested therein of such fact by a publication of such notice in some newspaper printed and published at the city of Saint Paul, in said State of Minnesota, for three successive days.

SEC. 6. For a failure on the part of said measurer to perform any of his duties under this act, or for any mismeasurement of such grasshoppers and their eggs, he shall be deemed to be guilty of a misdemeanor, and be subject to pay a fine of not less than ten dollars nor more than one hundred dollars, or be imprisoned in the county jail for a term of not less than thirty nor more than ninety days, in a suit or proceeding to be prosecuted in the name of the State of Minnesota, in the same manner as is provided by law in other cases of misdemeanor.

SEC. 7. Upon the presentation of such certificate to the county auditor, he shall issue a certificate to the person entitled thereto for the amount due him, (a form of which certificate shall be furnished by the State Auditor), and shall make an order upon the State Auditor for the amount thereof, and the State Auditor shall draw his warrant upon the State Treasurer for that amount, in favor of the parties holding said certificates, which shall be paid by the State Treasurer on presentation: *Provided*, That all certificates presented to the county auditor for payment shall be by him filed and preserved in his office, and he shall present such certificates to the board of county commissioners, who shall audit the same in the manner now provided by law for auditing accounts against counties; and no money shall be drawn from the State Treasury until such certificates have been audited and allowed in the manner herein provided. And that no money shall be paid under the provisions of this act at any time prior to the fifteenth day of July, A.D. eighteen hundred and seventy-seven, and that the money hereby appropriated shall only apply to certificates duly made and filed with the Auditor of State on or before said day; that at the time after the State Auditor shall ascertain the total amount of all claims and certificates so filed, and if the same shall exceed in amount the sum of one hundred thousand dollars, then the said claims shall be paid *pro rata*, and no other or greater amount than said sum of one hundred thousand dollars shall ever be paid under the provisions of this act: *And provided further*, That if the amount hereby appropriated is not sufficient to pay the certificates in full, the balance shall be paid by the counties respectively, according to the amount due on said certificates as issued by such county.

SEC. 8. Every male inhabitant of the several townships in the said afflicted counties, being above the age of twenty-one years and under the age of sixty years, excepting paupers, idiots and lunatics, shall be assessed by the board of supervisors of said township to work one day in each week in said township, during the period hereinbefore mentioned, for the paying of bounties for the purpose of catching and destroying grasshoppers and their eggs, for five weeks from the time said grasshoppers shall become large enough to be taken; and the amount of work to be so assessed shall not exceed five days in all.

SEC. 9. The supervisors aforesaid shall make a list of the names of all persons against whom said tax shall have been assessed, and place in a column opposite each name on said list, the amount of

labor assessed against such person, and shall direct the town clerk to make a certified copy of each list, after which the town clerk shall deliver the several copies to the respective overseers of the highways of said townships.

SEC. 10. The overseers of highways shall give at least two days' notice to all persons assessed to work as aforesaid, living within the limits of their respective districts, of the time and places where and when they are to appear for that purpose, and with what implements.

SEC. 11. Every person liable to work, as provided for in this act, may commute for the same at the rate of one dollar per day, in which case such commutation money shall be paid to the chairman of the board of supervisors, to be applied and expended by him for the destruction of grasshoppers and their eggs, and he shall be authorized and required to hire and engage some suitable and efficient person to work in the place of said person so commuting, and to pay him the sum of one dollar per day for his services; and every person intending to commute for his assessment shall, within five days after he is notified to appear and work as aforesaid, pay the commutation money for the work required of him by said notice, and the commutation shall not be considered as made until such money is paid.

SEC. 12. Every person so assessed and notified, who shall willfully neglect or refuse to commute or work as provided by this act, shall be guilty of a misdemeanor, and shall, on conviction thereof, be liable to pay a fine of not less than two dollars nor more than ten dollars, or by imprisonment in the county jail not more than ten days, or both, in the discretion of the court, in a suit to be prosecuted in the name of the State of Minnesota, in the same manner as is provided by law for prosecutions of misdemeanors.

SEC. 13. There shall be appropriated, out of any moneys in the treasury of this State, not otherwise appropriated, for the purpose of carrying out the provisions of this act, the sum of one hundred thousand dollars.

SEC. 14. The board of county commissioners of any county in this State afflicted by grasshoppers, shall have the right, if in their judgment they see fit, to employ one or more persons in each township in said county with such implements or mechanical contrivances as may prove most efficient to destroy the grasshoppers, from the first day of April to the first day of August in each year, paying such persons either by the day or a specified sum for the amount captured and destroyed. The compensation of such person shall be paid out of the general fund of the county: *Provided further*, That parties employed and paid by the county commissioners shall not receive any other or further compensation under the provisions of this act.

SEC. 15. This act shall take effect and be in force from and after its passage.

Approved March 1, 1877.

More complicated than the others, this Minnesota act has certain special features which are intended to meet the peculiar emergency in that State. Yet I do not think the act is so clear or will prove so effectual as the first Kansas act. In addition to this bounty act, the Minnesota Legislature passed another, appropriating \$75,000 for the purchase and distribution of seed grain to the sufferers from locust injuries.

NEBRASKA — AN ACT TO PROVIDE FOR THE DESTRUCTION OF GRASSHOPPERS.

Whereas the State of Nebraska has, for the past three years, been devastated by the grasshoppers, thereby greatly injuring the agricultural and commercial interests of the State; and whereas these interests are liable to be seriously damaged in the future by the recurrence of the pests aforesaid; therefore,

*Be it enacted by the Legislature of the State of Nebraska.*

SECTION 1. That the supervisors of each road district in this State shall, at the time when the grasshoppers shall have been hatched out, and before the same shall become full-fledged and fly, notify each able-bodied male resident of his district, between the ages of sixteen and sixty years, to perform two days' labor, at such time and at such place and in such manner as shall by said supervisors be deemed most efficient in the destruction of the grasshoppers; said notices shall be given in the same manner as is provided by law for the notice to work upon public highways.

SEC. 2. Cities of the first and second class shall be governed by the provisions of this act, and it shall be the duty of the mayor of such cities to appoint, not exceeding two supervisors for each ward, to oversee the labor to be performed under the provisions of this act.

SEC. 3. In case it shall appear that two days' work is not sufficient to destroy the grasshoppers in any district or ward, and it shall further appear that more time can be profitably employed in the destruction of the grasshoppers, the supervisors of each ward or road district may require from the persons liable to the provisions of this act, not exceeding ten days' labor in addition to the time hereinbefore mentioned; and it shall be the duty of such supervisor to give to each person who shall have performed labor under the provisions of this section a receipt for the number of days' labor performed, and the supervisor shall upon oath report to the city or county authorities the names and amount of labor performed by each person.

SEC. 4. It shall be the duty of all persons subject to the pro-

visions of this act to attend when notified as herein provided, and labor under the direction of the supervisor of their respective district or ward. Any person who, after being notified, shall refuse, neglect, or fail to comply with the provisions of this act, shall forfeit and pay to the county or city treasurers, as the case may be, the sum of ten dollars, together with costs of suit, which sum shall be collected by suit before any justice of the peace within the county, in an action to be brought in the name of the city or county.

SEC. 5. The supervisor shall report, under oath, to the city or county authorities the names of all persons who shall have refused or failed to comply with the provisions of this act.

SEC. 6. This being a case of emergency, this act shall take effect and be in force from and after its passage.

In reference to bounty laws, the experience of Minnesota, where they were in force in some counties in 1875, is valuable, and the State Commissioners did not hesitate to recommend the system after the county trials, imperfect as they were, and commenced as they were, in most cases, too late in the season. It was clearly shown that in one township \$30,000 worth of crops was saved by an expenditure of \$6,000. Nicollet county paid \$25,053 for 25,053 bushels of locusts, but the price paid by other counties was higher; in fact, much too high. A good law, once enacted and on the statute books, might not be called into operation for many years, but would beyond all doubt serve an admirable purpose in the event of a locust invasion. The following are what I conceive should be the essential features of an efficient bounty law: 1. *The bounty should be paid out of the State Treasury; or it should be graded and borne equally, one-third by the local Township, one-third by the County, and one-third by the State.* 2. *The bounty should be immediately available to those earning it.* 3. *The Act should, so far as possible, tend to the destruction of the eggs.* 4. *After the eggs, the destruction of the newly-hatched locusts should be encouraged by the Act.* A bushel of the newly-hatched insects will contain thirty or more times as many individuals as will a bushel

of the pupæ, and, moreover, their destruction prevents the subsequent injury. It would be folly to pay sixty cents a bushel for them later in the season when they are nearly full-grown and have done most of the harm they are capable of doing. The price, therefore, should vary with the season; and while, in latitude 39°, 75 cents or \$1.00 should be offered in March, the price should diminish to 50 cents in April, 25 cents in May, and 10 cents in June. As the dates of hatching vary with the latitude, so the law should vary in the matter of dates, according to the requirements of each particular State. In addition to the foregoing requirements of such an act, every precaution should be taken to prevent fraud and dishonesty in obtaining the money.

The laws obliging proper labor will prove more beneficial to a community than the bounty laws, and the labor is best performed, first in destroying the eggs in the fall, and next in destroying the young insects after the bulk of them have hatched out in the spring.

In the more thinly settled parts of the country, laws may be more or less ineffectual, so far as the general destruction of the insects is concerned, though they will even there be one of the best means of relieving destitution; but in more thickly settled sections they will accomplish both results.



## CHAPTER IX.

---

### LOCUST RAVAGES EAST OF THE MISSISSIPPI.

#### RAVAGES OF MIGRATORY LOCUSTS IN THE ATLANTIC STATES.

WE have already seen how the true Rocky Mountain Locust, which rarely reaches the Mississippi, may be distinguished from the Red-legged species, which often mixes with it and is common to a much larger extent of country, and reaches to the Atlantic. We have also seen that the ravages of migratory locusts between the Mississippi and the Rocky Mountains, and probably to the Pacific, are confined to the one, long-winged species, (*spretus*). "How then," will naturally be asked, "do you account for the ravages of migratory locusts in the Atlantic States, since swarms have been known in those States to fly over the country and commit sad havoc, and since you tell us that the Red-legged species is incapable of such migrations?" This question, which was first properly answered in my 7th Report, I will now proceed to elucidate.

As to migrating locusts doing great damage in some of the Eastern States during certain years, there can be no doubt of the fact. Harris, in his Treatise on *Injurious Insects*, gives an account extracted from the Travels of President Dwight, wherein they are recorded as being most destructive in Vermont in 1797 and 1798, and as collecting in clouds, rising in the air and taking extensive flights — even covering persons employed in raising a

church steeple, who, in such position, still saw the insects flying far above their heads. He also quotes from Williamson's History of Maine, that in 1749 and 1754 they were very numerous and voracious; that "in 1743 and 1756 they covered the whole country and threatened to devour everything green." Among the communications which I received in 1874 was the following, descriptive of locust ravages in New Hampshire :

DEAR SIR: I see a note in the New York *Tribune* requesting those from the locust regions to send you specimens of the variety. I send you a vial of them to-day by mail. They have been quite plenty in the Merrimack Valley on some farms. They have eaten all of our garden vegetables; in others they left us a small share. The small ones are the most plenty and the ones that have done the most mischief. I should like to know if they are of the same variety that infested the West.

Yours truly,  
LEWIS COLBY.  
BOSCAWEN, MERRIMACK Co., N. H., Sept. 17, 1874.

The following account by Dr. U. T. True of the appearance of these insects in Cumberland county, Maine, in 1821, is so circumstantial that I give it in full, as quoted by Mr. S. H. Scudder:\*

During the haying season the weather was dry and hot, and these hungry locusts stripped the leaves from the clover and herds-grass, leaving nothing but the naked stems. In consequence, the hay-crop was seriously diminished in value. So ravenous had they become that they would attack clover, eating it into shreds. Rake and pitchfork handles, made of white ash and worn to a glossy smoothness by use, would be found nibbled over by them if left within their reach.

As soon as the hay was cut and they had eaten every living thing, they removed to the adjacent crops of grain, completely stripping the leaves: climbing the naked stalks they would eat off the stems of wheat and rye just below the head, and leave them to drop to the ground. I well remember assisting in sweeping a large cord over the heads of wheat after dark, causing the insects to drop to the ground, where most of them would remain during the night. During harvest time it was my painful duty, with a younger brother, to pick up the fallen wheat heads for threshing; they amounted to several bushels.

---

\* Hayden's Report on the Geological Survey of Nebraska; and "The Distribution of Insects in New Hampshire," p. 375.

Their next attack was upon the Indian corn and potatoes. They stripped the leaves and ate out the silk from the corn, so that it was rare to harvest a full ear. Among forty or fifty bushels of corn spread out in the corn-room, not an ear could be found not mottled with detached kernels.

While these insects were more than usually abundant in the town generally, it was in the field I have described that they appeared in the greatest intensity. After they had stripped everything from the field, they began to emigrate in countless numbers. They crossed the highway and attacked the vegetable garden. I remember the curious appearance of a large, flourishing bed of red onions, whose tops they first literally ate up, and not content with that, devoured the interior of the bulbs, leaving the dry external covering in place. The provident care of my mother, who covered the bed with chaff from the stable floor, did not save them, while she was complimented the next year for so successfully sowing the garden down to grass. The leaves were stripped from the apple trees. They entered the house in swarms, reminding one of the locusts of Egypt, and, as we walked, they would rise in countless numbers and fly away in clouds.

As the nights grew cooler they collected on the spruce and hemlock stumps and log fences, completely covering them, eating the moss and decomposed surface of the wood, and leaving the surface clean and new. They would perch on the west side of a stump, where they could feel the warmth of the sun, and work around to the east side in the morning as the sun reappeared. The foot-paths in the fields were literally covered with their excrements.

During the latter part of August and the first of September, when the air was still dry, and for several days in succession a high wind prevailed from the northwest, the locusts frequently rose in the air to an immense height. By looking up at the sky in the middle of a clear day, as nearly as possible in the direction of the sun, one may descry a locust at a great height. These insects could thus be seen in swarms, appearing like so many thistle-blows, as they expanded their wings and were borne along toward the sea before the wind; myriads of them were drowned in Casco bay, and I remember hearing that they frequently dropped on the decks of coasting vessels. Cart loads of dead bodies remained in the fields, forming in spots a tolerable coating of manure.

Mr. I. S. Smith says that he has seen "hackmatack trees almost covered with them, and entirely stripped of their leaves." \*

All these accounts agree in referring the injury to the common Red-legged Locust; but as I am fully persuaded that this species, as found in Illinois and Missouri, is inca-

---

\* Rep. Connecticut State Bd. of Agr., 1872, p. 363.

pable of any extended flight,\* I could not help feeling that some other species had been confounded with it, and had played the part of migratory locust in the White Mountain regions of Maine and New Hampshire. It was with satisfaction, therefore, that, upon examining the locusts sent me by Mr. Colby, I found them to belong to the species defined in Chapter I, as *Atlantis*, which is smaller than either the Rocky Mountain or the Red-legged species, but in structure and relative length of wing much more nearly resembles the former than the latter; in other words, its relative length of wing enables it to fly with almost the same facility as its Rocky Mountain congener.

#### INJURY FROM OTHER, NON-MIGRATORY LOCUSTS.

Almost every year, in some part or other of the country, we hear reports of injury by locusts. In 1868, for instance, while the Rocky Mountain species was attracting attention, as I have already stated, (p. 37), in many parts of the West, other non-migratory species were extremely injurious in the Mississippi Valley, and in the Eastern States. In Ohio they appeared in countless myriads during that year, and at the meeting of the Cincinnati Wine Growers' Society it was stated that they invaded the vineyards, destroying entire rows, defoliating the vines and sucking out the juices of the berries. In the same year I saw them in countless millions in many parts of Illinois and Missouri. They actually stripped many corn-fields in these States, and had not the crops been unusually abundant, would have caused some suffering. They were very destructive to flower and vegetable gardens.

---

\* I do not mean by this that it is incapable of rising in the air; but I am quite sure that as found in St. Louis county it is incapable of any such flights as *spretus* takes. In the higher parts of the country, whether East or West, the power of flight may be greater.

In 1869, they were, if anything, worse than in 1868. I remember that in the vicinity of St. Louis, in addition to their ordinary injuries, they stripped the tops of Norway Spruce, Balsam Fir and European Larch; took the blossoms off Lima beans; severed grape stems, and ate numerous holes into apples and peaches, thereby causing them to rot. They were indeed abundant all over Illinois, Missouri, Iowa, and even Kentucky; but attracted no attention East.

In 1871 they were again very destructive, especially East, as the following items will show:

The grasshoppers (locusts) have been more numerous and destructive this year, in Maine, than perhaps ever before. This was partly owing to the dry weather, and with the advent of the rainy season we hope their career will be somewhat checked. In this county they are thick, but in some of the central portions of the State they literally swarm, devouring nearly every green thing before them. They did much injury to the grass fields, and, now that is cut, they have betaken themselves to the cultivated crops. In some cases, whole fields of corn and beans have been completely stripped. Even the potatoes have not been spared.—[*Country Gentleman*, Aug. 10, 1871, speaking of Insects in Maine.

Grasshoppers are reported to have very seriously injured the corn, grass and grain crops (and in some cases orchards and nurseries) of the counties of Androscoggin, Franklin, Knox, Kennebec, Lincoln, Oxford, Piscataquis, Penobscot, Waldo and Somerset, in Maine. So serious has been the damage that the subject was made a topic at the recent State Agricultural Convention in that State. In Androscoggin county, they injured pastures greatly, and affected the condition and price of stock. Some grain fields were protected by drawing a rope across the heads at sunset, thus brushing off the insects and preventing feeding. In Franklin county, a field of twelve acres of sweet corn was only saved by keeping a man in it continually to drive out the grasshoppers. One man in York county stopped their passage to his fields by building a brush fence around them.—[*American Agriculturist*, 1871.

These pests (the locusts) have been numerous and destructive during the past month, in some portions of the Eastern States. In Sagadahoc county, Maine, the crops and pastures were injured by them very much; also in Hancock county. In Franklin, many fields of grain were cut to save the crops from them and for feeding. In Oxford, oats were "eaten entirely down, as clean as though fed upon by sheep." In some portions of Plymouth county, Mass.,

they are reported to have eaten everything green. In Caledonia county, Vermont, they have been very destructive. All through Windsor they have been "a terrible scourge." In Orleans they are reported abundant, and in Windham they have done "much injury to some of the crops." In Wayne county, Pennsylvania, also, they are reported to have done much damage.—[Monthly Report Dep. of Agr. for August and September, 1871.

In 1872 they were again injurious East :

The grasshoppers are making great havoc on the grass, grain and corn. For a space of about one and a half miles square, they are destroying almost everything. Clover is trimmed up all but the head ; oat fields look like fields of rushes coming up to the height of sixteen to eighteen inches without leaf or head. The leaves of wheat and their kernels are eaten out. These hoppers move back and forth two or three times a day, and whole sections are almost alive with them.—[*Mirror and Farmer* (New Hampshire), August 10, 1872.

In 1874, again, much injury by them was reported in the Mississippi Valley and eastward, and a few extracts will suffice to indicate how numerous they often were :

The grasshoppers destroyed four acres of my wheat last fall ; ate and destroyed my timothy twice ; sowed the ground again this spring, but as there are still plenty of hoppers, there is not much hope for a stand.—[Letter extract from G. Pauls, Eureka, Mo., Nov. 10, 1874.

Some of our good friends in Suffolk county, Virginia, were unduly excited this summer over the idea that the Western destructive grasshopper, *Caloptenus spretus* of Uhler, had found its way to the "sacred soil of Virginia." There was no denying the fact that myriads of grasshoppers were devouring nearly "every green thing," even settling on the trunks and limbs of trees, and gnawing the bark in a most unkind manner ; and as it appeared to be something altogether foreign to the locality, of course it must be the Western pest. Specimens were forwarded to us, however, and a glance was sufficient to show us there was no need for alarm, as it was quite a common species in this part of the United States, and though rather too plentiful in this particular locality, would not spread or become the terror that its Western distant relative has proved. The insect is known as the *Acridium Americanum*, and is of large size, often measuring over two and a half inches in length.—[C. R. Dodge, in *Rural Carolinian*, November, 1874.

In 1875, again, the indigenous species were very abundant, and were often supposed to be the genuine *spretus*, the

young of which were at the time devastating portions of the West. The reports of this last in Jefferson, Franklin and Moniteau counties in the Monthly Report of the Department of Agriculture for November and December of that year, undoubtedly refer to indigenous species, and are a sample of the reliability of much of the entomological information that comes through that channel. They were troublesome not only in the Mississippi Valley, but in the East, for I know that they did great damage to oats and meadows in Southwestern Pennsylvania, and the following items doubtless refer to *Atlanis* and *femur-rubrum*, and will show how injurious they were in Massachusetts :

GRASSHOPPERS IN BOSTON.—We did not anticipate that Boston proper would ever be inconvenienced by the pests which have proved so destructive out West, but it is a fact that grasshoppers are so numerous at the South End that they destroy the flowers in the back yards to such an extent that hens are hired or bought to clear the premises and save the ornamental plants which adorn the premises. These insects are not of the western pattern, but are native productions. If their ravages continue, it is possible some of our western friends will be called upon to raise subscriptions for the relief of the floriculturists of Boston.—[*Boston Journal*.

I venture to ask your advice in a grasshopper matter. Three years ago a party of farmers and others in this commonwealth, tired of granite hills, gravel banks and sand flats, and wishing some little latent fertility in the original soil—combined to effect, and did effect, the reclamation from the sea of about 1400 acres of what originally was 'salt marsh.' We are amply satisfied of the fertility of this land, and so far, all is good. Last summer, however, this land and adjoining territory was scourged with a plague of locusts or grasshoppers. Whether they came in such numbers owing to the diking of these 1400 acres, or whether they would, last year, have come in equal numbers whether the marsh was diked or not, we can not say. Our question is this, and is at the same time the point upon which we pray your advice : Can we do anything to diminish the number of these pests for next year ? We could, for example, flood this whole tract of land until early spring. Would this be advisable ? Any points you would be kind enough to give us on the matter, would be thankfully received.—[Letter from C. Herschel, Boston, Mass., latter part of October.

In short, during hot and dry years, which are favorable to the multiplication of crickets and locusts, more or less

injury is done in all parts of the country, by species indigenous to the different localities, but which in ordinary seasons do not attract any special attention.

The principal depredator in such cases, in the Mississippi Valley, is the wide-spread Red-legged Locust, already

[ Fig. 37. ]



DIFFERENTIAL LOCUST.

described and illustrated, (p. 14), and so often confounded with the true migrating Rocky Mountain species. The next most injurious is the Differential Locust (*Caloptenus differentialis*, Walk., Fig. 37), a species at once distinguished in the more typical specimens, from the preceding, not only by its larger size, but by its brighter yellow and green colors. The head and thorax are olive-brown, and the front wings very much of the same color, and, without other marks, have a brownish shade at base, the hind wings being tinged with green; the hind thighs are bright yellow, especially below, with the four black marks as in *spretus*, and the hind shanks

[ Fig. 38. ]



TWO-STRIPED LOCUST.

are yellow, with black spines, and a black ring near the base. Next in injuriousness comes the Two-striped Locust, (*Caloptenus bivittatus*, Say, Fig. 38), also a larger species, of a dull, olive-green color, the hind thighs conspicuously yellow beneath, and with two yellow lines extending from above the eyes

and with two yellow lines extending from above the eyes



along each side of the thorax superiorly, and thence, more distinctly on the front wings, narrowing and approaching toward their tips, when closed. All these species belong to the same genus as our Rocky Mountain Locust, and, except in being unable to sustain long-continued flight,\* agree with it in habit.

There are several locusts belonging to other genera which are common over large areas from the Atlantic to the Mississippi; and some of them, belonging to the genera *Acridium* and *Ædipoda* have relatively longer wings than the common Red-legged Locust, and consequently greater power of flight. Yet they are seldom as injurious as the short-winged Calopteni just enumerated, and the swarming of *Acridium Americanum* (our largest species), as presently described and as recorded in the paragraph from the *Rural Carolinian*, (*ante*, p. 192), is quite exceptional.

LOCUST FLIGHTS IN ILLINOIS IN 1875.

The manner in which some writers have clung to the idea that the Rocky Mountain Locust must overrun Missouri, Illinois, and the States to the East, in spite of opposing facts, can be accounted for only by inordinate love of magnifying possible danger and of making as much of a sensation as possible out of any misfortune that befalls a community. A certain amount of apprehension is pardonable; and that, under such apprehension, all sorts of

---

\* Their power to sustain flight will increase as we approach the higher and drier western country toward the mountains, and, I believe, according as the season of their growth in any part of the country is hot and dry. The colors, also, become brighter and lighter as we go west, with a tendency to increase of wing-length, and a diminution of body-bulk. This is very noticeable in traveling over the Western plains, where *bivittatus*, for instance, which, ordinarily, is far more destructive than *spretus* is to gardens in Western Kansas and Colorado, loses much of its dull, olive-green color, and is brighter- and lighter-colored and longer-winged, on an average, than at St. Louis.

insects, some of them having no relation to locusts, should be mistaken for the Rocky Mountain pest, is natural with persons who have had no acquaintance with it, and are unfamiliar with its appearance. In Sept. of 1875, many prominent papers of the West gave the news that the dreaded swarms had finally come into Illinois. In point of fact, large swarms of locusts did pass over the central portion of that State, early in September, and more particularly over parts of Livingston, McLean, Vermillion, Ford, and Champaign counties. Small and scattered flights were also seen later in the month. Some writers jumped to the conclusion that said swarms were of the Rocky Mountain species, without, however, giving a particle of proof. There is nothing absolutely impossible in the occurrence of scattering swarms of the genuine *spretus* in Illinois the year following a general invasion such as we had in 1874; for while I have expressed the opinion that the species will never do any damage east of the 94th meridian, I have admitted that it may temporarily extend to some distance beyond that line. But in 1875 we had no reports of swarms passing over the country to the Northwest or the northwest part of Illinois, prior to their occurrence in the middle counties, and I felt so confident that the swarms were composed of indigenous species, that I so stated my belief in the *Chicago Evening Journal* of Sept. 9th of that year, and expressed the opinion that they had originated within the borders of the State; that there was no occasion for alarm, and that they would scarcely be heard of after they settled. These opinions were subsequently justified by the facts; for after taking every pains to ascertain the truth, all specimens from such flights, examined by competent persons, proved to be indigenous species. We heard nothing of their ravages or of their rising again and passing over the country to the south or

east. Moreover, their flight seems to have been irregular, and poorly sustained. Mr. H. P. Beach, County Judge of Ford county, Ill., in sending me specimens, wrote, September 15 :

About ten days ago, myriads of grasshoppers flew southward over town. Many of them came down, evidently unable to keep up the journey. They seemed to be all the way from a hundred feet to a quarter or half a mile high, or perhaps very much higher. In looking up toward the sun—the only way they could be seen—the appearance was much like that of a snow-storm looked at in the same way. We have not heard from them since, and of course can give you no idea from “whence they cometh and whither they goeth.”

Mr. B. F. Johnson, the Champaign (Ill.) correspondent of the *Country Gentleman*, who supposed the species to be *spretus*, also in speaking of these flights, wrote to that paper (Sept. 16, 1875) :

When first seen, their movements and motions were so unlike what I had conceived their flights to be, that it was not till several disabled or partially exhausted insects had been caught, and their identity with the Kansas species demonstrated, that I was convinced of their true character. I had supposed that these creatures flew in a manner as pigeons and ducks and geese do—straight ahead in a given direction, and with a purpose. On the contrary, every insect seemed to be out on a holiday, and acting independently of all the others. While the vast mass slowly moved south, with an inclination toward the east, there was a constant circular movement of a vast majority of the whole number of individuals. \* \* \* When it got noised abroad that they were flying, the fact produced a startling sensation. Would they increase in numbers till the sun was darkened, and then descend and devour up every green thing, and leave eggs for a progeny behind them that would repeat the disaster next summer? These fears were speedily dispelled when their numbers were seen to diminish, and when it was considered that all the grasshoppers which had passed over, did they come down could make but small impression on the ten thousand square miles of corn in Central Illinois.

Actual examination of specimens from these flying bevies over Illinois, showed them to have been composed of three species, viz., the Red-legged, the Atlantic and the Differential locusts: in no instance was a specimen of

*spretus* seen. The several specimens obtained from Ford county were all *Atlantis*; a single specimen received from Mr. H. J. Dunlap, of Champaign, was a male *femur-rubrum*; while specimens taken by Prof. Burrill, of the Industrial University, at the same place, as well as others from Norwood, Mercer county, sent to Prof. Thomas, were *differentialis*. The parties capturing these specimens are not apt to fall into error, and are all positive that the specimens submitted were from the flying beevies.

From these facts it results that two species, viz., *femur-rubrum* and *differentialis*, though normally having no migratory habit, and, as I believe, incapable of extended flights, can actually assist in such flights. That the bulk of these Illinois swarms was composed, however, of *Atlantis*, scarcely admits of a doubt. The other two, less able to sustain lengthened flight, would naturally be most near the ground and most often captured; while *Atlantis*, which we now know to occur in this part of the country as well as East, and to often display the migratory habit, would fly higher.

There are two facts which it will be well to bear in mind in this connection, as explaining the above phenomena. The first is, that *Atlantis* was very common in Missouri, even in fields where it had never been noticed before. It prevailed to such an extent in Illinois, that around Carbonale Prof. Thomas could not find a single specimen of the typical *femur-rubrum*, and there was not a single specimen of it among a number which he caused to be collected for me.

The second fact is, that *differentialis* was also unusually abundant. A letter from Mr. M. Brinkerhoff, of Onarga, Illinois, dated October 18, 1875, and accompanied by specimens, describes them as in great numbers there, filling the

ground with their eggs.\* The following, which refers to the same species, is also interesting :

While the migrating hopper committed such devastation west of us, we here at Bluffton have the manor-born, in immense numbers. A patch of potatoes and some sweet corn seemed in danger of being consumed, when a flock of purple grackles, our crow blackbird, as it is usually called, came to our rescue. The few days that they have visited the patch has thinned out the hoppers amazingly. I never before noticed that this bird was so useful in this respect ; and as they are plenty, we may expect to be rid of the big grey fellows (hoppers). They are more than twice the size of the Colorado hopper, and are nearly as bad on a crop when plenty. What saved our little crop from utter destruction was an open field of land thickly covered with wild chamomile, upon which they fairly swarmed. On this we saw them as thick as the Colorados, in Sedalia or Warrensburg.—[S. Miller, in *Rural World*, August 14, 1875.

Though unusually common, yet *differentialis*, if I may judge from my own experience in our fields and around Chicago, that year, compared only as one to fifty with *Atlantis*, and it is doubtful if it formed a larger proportion of the flights. How are these exceptional migrations of local species to be explained? We know, from what has preceded, that they have occurred at intervals in the East, and we now have evidence that they may occur in any part of the country ; and indeed local swarms were not confined to Illinois in 1875, as they were also noticed in Kentucky. I think the explanation is simple. The excessively hot, dry years of 1873 and 1874 permitted the undue multiplication of these native species, and they were already very troublesome in the latter year, (*ante*, p. 192). The myriads that hatched out in 1875 were

---

\* The eggs of *Caloptenus differentialis* may be distinguished from those of *spretus* by the larger and more irregular size of the mass ; by the greater number composing it ; by the somewhat larger size of the individual egg, which measures 0.19—0.22 inch in length ; by the coarser reticulations of the shell, and by the brown color of the gummy fibrous matter that is intermixed with them and glues them together. The color of the egg varies from yellow to deep carneau, the latter prevailing, and the posterior or narrower end is always somewhat constricted and darker.

scarcely noticed at first, and made little impression on the luxuriant vegetation that a wet and favorable season produced. By September, when a spell of dry weather cured the grass and the locusts had acquired full growth, we can imagine that they swarmed in much of the prairie country of Central Illinois. Whenever they abounded to an unusual degree the migrating instinct is developed, just as it is under like circumstances in many other insects, as butterflies and beetles, that are normally non-migratory. The reasons we can only surmise; but aside from those of hunger, etc., previously suggested, the annoyance and inconvenience to which the females, while attempting to oviposit, have to submit from their companions, under conditions of excessive increase, may have something to do with it. But mere increase in numbers would not give to species like *femur-rubrum* and *differentialis*, which are ordinarily heavy-bodied and short winged, the power of extended flight; and there is little doubt, in my mind, that the same exceptionally hot, dry seasons which permit this undue multiplication also modify the individuals, and cause a decrease in bulk and increase in wing-power. The facts support this view, for the flying specimens of *differentialis* sent to Prof. Thomas had, as he writes me, "the body lighter and the wings longer, and some of that peculiar fierce appearance belonging to migrating specimens;" and I have specimens from Kansas and Minnesota which differ so much in these respects from the more normal specimens as found at St. Louis in ordinary seasons, that they can scarcely be recognized as the same species. The casual observer knows how thoroughly plants are modified in size and habit by season and condition: the same holds true of insects, and more particularly in certain groups.

Given that over the vast prairie region of Central Illi-

nois, the insects were as thick as I found them in many fields around St. Louis, where every step would cause two or three hundred to rise ; and let this migratory instinct be developed, and the mystery of the Illinois flights vanishes. They are exceptional local phenomena : they are neither so strong nor so long sustained as those of the Rocky Mountain species ; nor are they in any sense to be so much dreaded.

In short, whenever the climate and conditions in the Mississippi Valley approach those existing in the native home of the Rocky Mountain Locust, some of our native species, and especially those nearest akin to it, also approach it in habit. If the climate of Illinois and Missouri were to permanently change in that direction, these species would become permanently modified ; but as there is no immediate danger of such a contingency, the Rocky Mountain Locust is the only species, here considered, that can properly lay claim to the migratory habit.

#### LOCUST FLIGHTS EAST OF THE MISSISSIPPI.

To the unscientific mind there are few things more difficult of apprehension than that species, whether of plants or animals, should be limited in geographical range to areas not separated from the rest of the country by any very marked barriers, or by visible demarcations. Yet such is the fact, known to every naturalist ; and the geographical distribution of species forms at once one of the most interesting and one of the most important studies in natural history. Some species have a very limited, others a very wide range ; and while in the course of time—in the lapse of centuries or ages—the limits have altered in the past and will alter in the future, they are, for all practical purposes, permanent in present time. These limits may in fact, for the purpose of illustration, be likened to those

which separate different nations. Though frequently divided by purely imaginary lines, the nations of Europe, with their peculiar customs and languages, are well defined. Along the borders where **two** nations join, there is sometimes more or less commingling ; at other times the line of demarkation is abrupt ; and in no case could emigrants from the one, long perpetuate their peculiarities unchanged in the midst of the other. Yet in the battle of nations, the lines have changed, and the map of Europe has often been remodeled. So it is with species. On the borders of the areas not abruptly defined, to which species are limited, there is more or less modification from the typical characters and habits ; while in the struggle of species for supremacy, the limits may vary in the course of time. The difference is, that the boundaries of nations result from human rather than from natural agencies, while those of species result chiefly from the latter, and are therefore more permanent. These remarks apply of course to species in a natural state, and where their range is uninfluenced either directly or indirectly by civilized man.

I found some difficulty, at the Conference of Governors at Omaha to consider the locust problem, in satisfying those present that the Rocky Mountain Locust could not permanently thrive in the country indicated by green in Plate I. of this work, and that there was no danger of its ever extending so as to do serious damage east of a line drawn a little west of the center of Iowa. They could not see what there was to prevent the pest from overrunning the whole country, and thought that Congress should be appealed to, not only on behalf of the country that has suffered from its ravages, but on behalf, also, of the whole country that is threatened thereby.

Having already discussed the native home of the species, and the conditions which prevent its permanent settlement



in the country to which it is not native, it is unnecessary here to go into detail on these points. Briefly, the species is at home and can come to perfection only in the high and dry regions of the Northwest, where the winters are long and cold and the summers short ; and whenever it migrates and oversweeps the country to the South or Southeast, in which it is not indigenous, the changed conditions are such that the first generation hatched out in that (to it) unnatural climate, either forsakes it on the wing or perishes from debility, disease and general deterioration. On the soundness of this conclusion depends the future welfare of most of the more fertile States between the Mississippi and the mountains, and science, as well as past experience, shows it to be sound. Upon this hypothesis the people of nearly the whole country, so scourged during the past few years, may console themselves that the evil is but temporary : they may have to fight their tiny foe most desperately for a short time, but they nevertheless have the assurance that even if he prove master of the field, he will vacate in time to, in all probability, allow of good crops of some of the staples, and that he may not return again for years. On the other hypothesis—for which there is only apparent, and no real reason—ruin stares them inevitably in the face.

The causes which limit the eastward flight of the winged swarms that come from the Northwest are, with the majority of people, still more difficult to appreciate ; for most persons can see no reason why a swarm that overruns the western portions of Minnesota, Iowa and Missouri, should not extend to the eastern borders of the same States, or into Illinois, Indiana, Ohio and eastward. Having previously considered the more occult climatic influences that bear on the belief that they never will, I need only state here, that the principal arguments rest in

the facts that—1st, the power of flight of any insect that has a limited winged existence, must somewhere find a limit ; 2d, that all past experience has shown that *Caloptenus spretus* has never extended, in a general way, beyond the limit indicated, and that as long as the present average conditions of wind and climate and of timber-distribution prevail, it is reasonable to suppose that it never will.

One of the principal difficulties in the way of a proper apprehension of the facts, is found in the failure, in the popular mind, to discriminate between species. The ordinary newspaper writer talks of *the* grasshopper, or *the* locust, as though all over the country and all over the world there was but one and the same species. One of the Governors present at the Conference referred to, was at first fully of the belief that our Rocky Mountain pest came all the way from Asia. In the case of this destructive species, even some entomologists have added to the difficulty by erroneously claiming that it is common all over the country to the Atlantic ocean.

The above thoughts were suggested by the following reports, that met my eye, in the *Cincinnati Gazette* of the 24th of October, 1876, from Dayton and Hamilton, respectively, in the State of Ohio:

The advent of Kansas grasshoppers, over Sunday and until Monday evening, in great numbers throughout the city, is a most remarkable incident. They were found early Sunday morning, and left, as suddenly as they came, on Monday evening.

A shower of mammoth grasshoppers came down upon our town and vicinity on Saturday night. We have never seen such large ones before, and we understand from old citizens, that they are entire strangers in this part of the country. We saw a boy have a string tied to two of them (which were as long as a man's finger) trying to drive them, and he succeeded pretty well.

A flock of grasshoppers alighted in Hamilton about 11 o'clock on Saturday night, from the northwest. Those that were not drowned in the river or killed by the heavy rain, were probably gobbled up before Sunday night by the chickens.

Such reports as these very naturally confirm the unscientific in the idea that the locust plague of the West, or so-called "Kansas grasshopper," has overstepped the limits entomology ascribes to it, and is upsetting the conclusions which I have come to. The same swarm passed over Oxford in the same State, in a southwesterly direction, and fortunately that veteran and well-known apiarian, the Rev. L. L. Langstroth, who has not forgotten to be a close observer, had specimens sent to me. They proved to be the American *Acridium* already figured and described on page 101, (Fig. 15). It has a wide range, hibernates in the winged condition, and not only differs in size and habits from the Rocky Mountain Locust, but entomologically is as widely separated from it as a sheep is from a cow. It is a species common over the country every year, and during exceptional years becomes excessively numerous and acquires the migratory habit, its wings being long and well adapted to flying. As I learn from Dr. S. Miller, of Franklin, it passed in swarms over part of Johnson county, Missouri, late in September; and it was everywhere abundant in 1876.

The following extracts from letters of correspondents refer to this species :

I send you by Mr. Shaw a small package containing specimens of locusts, destructive about Chattanooga and in all Eastern Tennessee. They strike me as nearly allied to the Rocky Mountain Locust; fly with the same noise and shine of wings, in large shoals, but are larger.—[Dr. G. Engelmann, Warm Springs, N. C., Aug. 29, 1876.

We have a locust here which has in some places occurred in considerable numbers, and some people think it the same as the one which has produced so much damage in the West. This I doubt, as it is evidently a native species.—[E. M. Pendleton, Prof. of Agriculture, Univ. of Ga., Atlanta, Ga., Sept. 14, 1876.

The American *Acridium* visited us on the night of November 21, (Saturday.) A rain fell during the night. Cambridge City, Indiana, was also visited by them on the same night.—[Herschel I. Fisher, Eastham College, Richmond, Ind.

Toward the end of July the unfledged insects did an immense amount of damage to the cotton and other crops of Georgia and South Carolina. The papers were full of graphic accounts of their destruction, and not only did editors very generally take for granted that they had to do with the western *spretus*, but Mr. T. P. Janes, Commissioner of Agriculture for Georgia, in his circular No. 27, supposed they were the same. Specimens which he subsequently sent me, however, at once revealed their true character.

The damage done by some of the more common locusts that occur over the country, is, let me repeat, sometimes very great, especially during hot, dry years. In some of the New England States their ravages have, in restricted localities, fairly equaled those of the voracious *spretus* of the West. But while a few of them, in exceptional circumstances, develop the migratory habit, they never have, and in all probability never will, compare with *Caloptenus spretus* in the vastness of its migrations and in its immense power for injury over extensive areas.

Whenever we hear of locust flights east of the Mississippi, we may rest satisfied that they are not of our Rocky Mountain pest, and are comparatively harmless.

## CHAPTER X.

### GENERAL CONSIDERATIONS.

#### NOMENCLATURE.

REGARDING the popular name of our insect, there is great lack of uniformity in the terms by which it is designated, and many of my readers, who have been accustomed to hearing these insects very generally called "grasshoppers," will doubtless wonder why I have not followed common usage. In America, the term "Grasshopper" is very generally employed for these insects, but should be abandoned for that of "Locust," which is applied to similar species in nearly all other parts of the world, the "locusts" of Scripture being very closely allied species. As I have already said (6th Mo. Ent. Rep., p. 153, note) :

It is to be regretted that American entomological writers do not more strictly follow Harris in conforming to the English custom of calling these insects—with short antennæ and stridulating by means of the stout hind legs—by the popular term of "locusts;" this being in keeping with ancient usage. The term "grasshopper" would then be confined to the long-horned and long-legged, green group, stridulating solely with the wings, in which the species are more solitary and never congregate in swarms, and in which the female is invariably provided with a sword or cimeter-shaped ovipositor; while the term Katydid could be used to designate the few larger, tree-inhabiting species of the group, so designated by Harris. Where the habit of calling the Cicada "Locust," and the "Locust" of ancient usage "Grasshopper," is so inveterate as in this country, it is not easy to change it; but it seems to me that the change is desirable, and if popular authors would only continue the example of Harris, the change would come about with the greater dissemination of entomological information.

Almost every entomological author has been under the necessity, at one time or another, of insisting that the "Grasshopper" of this country is the "Locust" of Europe

and of antiquity; or of endeavoring to clear up the confusion which results from the popular application of this last term to the Periodical Cicada or Harvest-fly—an insect (Fig. 39) which dwells, in its early life, under

[Fig. 39.]



CICADA, or mis-called locust: with one wing removed, so as to show the beak and ovipositor.

ground, and feeds by sucking the sap of trees, and which is no more capable, like the true locust, of devastating our grain fields than a calf is of killing and devouring our sheep. Yet the ceaseless preaching about the popular misapplication of these terms will avail nothing so long as the popular error is encouraged by the preachers themselves adopting the misapplication. The popular names of a country should be respected as much as possible, especially for objects peculiar to the country, and I would be the last to try and change them for trivial reasons; but when, as in this instance, the name used for centuries in the older countries, and become familiar as household words through the widely disseminated Scriptures, is supplanted by a new one, and transferred to an entirely different insect, there is no excuse for perpetuating the popular error.

We may talk of *shipping* a car-load, and of the *sun's rising*, from now till doomsday; and, though, to the intelligent and hypercritical mind the expressions will ever savor of incorrectness, no one is foolish enough to try and reform them, because they are universal, wherever the English language is spoken. Change in universal and long established customs is neither possible, as a rule, nor advisable; and it is doubtful if any reform could be brought about in our present Gregorian calendar, for instance, even if the advantage of regulating the divisions of the year by the astronomical conditions of the earth's orbit could be fully

established. But in a case like that of the use of the terms LOCUST and GRASSHOPPER, the former, as applied to our Rocky Mountain plague and its allies, has every claim to favor, not only because of its having been longer used, and of its now being more universally used than the latter; but because it has a definite meaning and agrees with the old systematic name of the family to which the species belongs; while the term "grasshopper" is most loosely applied to almost every field insect that hops. The term locust is, in fact, supposed by many to be derived from the Latin words *locus ustus*, signifying a burnt place, and referring to the desolation, as if by fire, which these insects cause.

The trivial terms "Colorado," "Red-legged," and "Hateful" have been applied to the species by various writers; but the name "Rocky Mountain Locust," which I have employed, is expressive of the insect's habitat and least open to objection.

Regarding the scientific name of our insect, it is only necessary to add, in addition to what has already been said, that it belongs to the modern genus *Melanoplus* of Stål; but just as this author's subdivisions of certain genera in Coleoptera are not accepted or recognized by many of our best coleopterists, so *Melanoplus* is not considered as of generic value by some of our best orthopterists; for which reason I have used the better known and well established genus *Caloptenus*. The specific name *spretus* (meaning despised) indicates that, as a species, it was long overlooked by entomologists, and confounded with *femurrubrum*.

#### PRAIRIE FIRES VS. LOCUST RAVAGES.

The statement has been made, and advocated with considerable ingenuity, that the visitations of the Rocky

Mountain Locust are due to the practice of burning off the dry grass of our Western prairies. All the arguments in this direction, however plausible at first sight, will not bear the test of close scrutiny. The theory is that burning the grass is the occasion of drouth, and that locusts come only in drouthy seasons. One writer in the *Kansas Farmer* for Sept. 23d, 1874, even asserts that "the unbroken succession of curses" that have afflicted that State, "all spring from the one first grand cause, the burning of the prairie grasses," and, after explaining that hot, scorching winds and simoons originate in desert countries, he avers that "it matters not whether the country is an original desert, or whether it is made so by the action of our Western prairie fires. For all present purposes the two are reduced to a common level and produce a common result—drouth, hot winds and locusts."

The reason given why the locusts can come only in drouthy seasons, is, that they can not fly in a moist atmosphere, and the facts that they do not readily fly early in the morning, and that the farther east you go, or, in other words, the more moist the atmosphere becomes, the insects diminish in number and consequent power for harm.

As such views are by no means uncommon in the West, I will give my several reasons for believing that there is no connection whatever between prairie fires and locust ravages.

1. It is by no means proved that the simoons which occasionally sweep over our Western States and Territories have their origin in any part of that vast prairie country. Some of the more local of these hot, dry winds may originate or acquire their peculiarly high temperature on the *mauvaises terres* of Wyoming or the table lands of Arizona and Mexico; but the more general simoons most probably



have their origin at a far greater distance from us, viz., in the tropics. These simoons in Missouri always blow from the southwest, in Kansas from south-southwest, and in Eastern Colorado south, or a few points east of south; and their injurious and scorching effects are not infrequently felt before the frost in Kansas and the country to the west is fairly out of the ground.

2. It is well known that the buffalo grass ranges over a vast extent of our Western plains, and that it does not furnish a very dense or thorough covering, even when unburned, and assists very little in retaining moisture or preventing evaporation.

3. My own observations for the past seventeen years in this Western prairie country lead me to the conclusion that fires more often succeed than precede drouth, and that they may more justly be looked upon as a result than as a cause of excessive dry weather; and the prevailing belief that large conflagrations or extensive fires are conducive to rain, bears on this point.

4. Whenever grass is burned during the growing season, the old and drier blade is soon succeeded by a green and succulent one, which has far greater power to attract and retain moisture; while if burned in winter time the evaporation from the soil can be thereby but slightly affected, because of the weakened power of the sun, and the snows which usually cover and protect.

5. Drouths are by no means confined to that portion of the country subject to the locust invasions.

6. The reason why locusts are more sluggish and less inclined to fly at morn than at noon is not so much a question of the comparative density of the atmosphere as of the difference in temperature. All diurnal insects are sluggish in the cool of the morning, and their activity increases with the rising of the thermometer; and flight,

whether of bird or insect, is, I conceive, easier, *cæteris paribus*, in a dense than in an attenuated atmosphere.

7. As the Rocky Mountain Locust multiplies continuously in the Rocky Mountain region, its descent into the plains to the east where it can not permanently thrive, can not well be affected by the burning of the grass on those plains.

From what has preceded I think we may safely conclude that the non-burning of the prairies will have no effect in preventing locust injuries, but that, on the contrary, as shown in Chapter VIII, the judicious burning of such prairies at the proper time is most beneficial and highly to be commended.

Indeed, there is only one way in which there can be any real connection between the burning of prairies and the ravages of the Rocky Mountain Locust, and that connection is through the remote past, and altogether beyond our present control. In the report of the Chief Signal Officer to the War Department for 1872, will be found an interesting account of the great fires of 1871 in the Northwest, in which the late Prof. J. A. Lapham, of Milwaukee, Wis., maintains that our extensive Western prairies and plains owe their existence and origin to the agency of fire. These fires, encouraged by drouth, and either kindled by accident or intention, have swept over the country for ages, and while they leave the roots of the grass uninjured, they destroy the germs of most other plants, including forest trees; and Mr. Lapham pictures to himself a long-past struggle between forest and prairie, in which the latter, by the assistance of the Fire King, has gained and held the vantage ground.

While I do not agree with Prof. Lapham that the remote cause of our prairies can be attributed to fire, yet no one can doubt its agency at the present time in main-

taining these prairies and preventing timber growth in the more humid portions of the great prairie region. But on Prof. Lapham's hypothesis there would naturally be a connection in the past between fires and locusts; for if without fires this whole prairie region had been timbered, the locusts, which are essentially insects of the plains and prairies, could never have become so prodigiously abundant and injurious. On such a hypothesis alone can I see any possible connection between prairie fires and locust invasions, and, however much truth there may be in the hypothesis, the fact remains that there is no present connection between the two phenomena.

#### FASTING AND PRAYER.

During great calamities, there has always been, and perhaps always will be, on the part of people of any religion whatsoever, a tendency to prayer and supplication, that Divine aid may come to the relief of the afflicted. This tendency is at no time more manifest than during locust visitations. It was illustrated in the passage of a resolution at the Omaha Conference, in 1876, praying the Supreme Being to avert future injury, and it has found expression in resolutions by religious sects and proclamations by State representatives, who doubtless receive from their constituency, during times of locust trouble, numerous petitions asking for such action.

The general interest awakened in the various endeavors to aid the sufferers in Missouri, in 1875, was in no small degree due to the active sympathy and the prompt attention given to the subject by Governor C. H. Hardin. About the middle of May he issued the following proclamation :

Whereas, owing to the failures and losses of crops, much suffering has been endured by many of our people during the past few months, and similar calamities are impending upon larger commu-

nities, and may possibly extend to the whole State, and if not abated will eventuate in sore distress and famine ;

Wherefore, be it known that the 3d day of June proximo is hereby appointed and set apart as a day of fasting and prayer, that Almighty God may be invoked to remove from our midst those impending calamities, and to grant instead the blessings of abundance and plenty ; and the people and all the officers of the State are hereby requested to desist, during that day, from their usual employments, and to assemble at their places of worship for humble and devout prayer, and to otherwise observe the day as one of fasting and prayer.

In testimony whereof, I have hereunto set my hand, and caused the great seal of the State of Missouri to be affixed, in the city of Jefferson, this 17th day of May, 1875.

C. H. HARDIN.

By the Governor :

M. K. McGRATH, Secretary of State.

This proclamation naturally drew forth a large amount of comment, and the Governor was ridiculed or praised according as fancy inspired newspaper men. As I was myself taken to task by no less a personage than the Reverend Doctor W. Pope Yeaman, of the Third Baptist Church of St. Louis, for supposed ridicule, and for taking "unnecessary pains to sneer at Providence," it may be as well to state that the only sentiment I ever expressed, either by word of mouth or by pen, as to the proclamation, is contained in an article published in the *St. Louis Globe* of May 19, 1875, where I wrote :

I deeply and sincerely appreciate the sympathy which our worthy Governor manifests for the suffering people of our western counties, through the proclamation which sets apart the 3d of June as a day of fasting and prayer that the great Author of our being may be invoked to remove impending calamities. Yet, without discussing the question as to the efficacy of prayer in affecting the physical world, no one will for a moment doubt that the supplications of the people will more surely be granted if accompanied by well-directed, energetic work. When, in 1853, Lord Palmerston was besought by the Scotch Presbyterians to appoint a day for national fasting, humiliation and prayer, that the cholera might be averted, he suggested that it would be more beneficial to feed the poor, cleanse the cesspools, ventilate the houses and remove the causes and sources of contagion, which, if allowed to remain, will infallibly breed pestilence, "in spite of all the prayers and fastings

of a united but inactive nation." We are commanded by the best authority to prove our faith by our work. For my part, I would like to see the prayers of the people take on the substantial form of collections, made in the churches throughout the State, for the benefit of the sufferers, and distributed by organized authority ; or, what would be still better, the State authorities, if it is in their power, should offer a premium for every bushel of young locusts destroyed. In this way the more destitute of the people in the infested districts would have a strong incentive to destroy the young locusts, and thus avert future injury, and at the same time furnish the means of earning a living until the danger is past. The locusts thus collected and destroyed could be fed to poultry and hogs, buried as manure, or dried, pulverized and sold for the same purpose.

Though I may not have overmuch piety and faith myself, I at least know how to respect those qualities in others, and however much I believe that the insect which was the remote cause of Dr. Yeaman's sermon, is governed by natural laws, which should guide us in understanding and overcoming it, the reverend gentleman forgot his calling, and made himself ridiculous, in charging, for such reasons, that I took pains to "sneer at Providence."

As the most effective and substantial method of observing the day of fasting and prayer, and as a result of the suggestion above quoted, Gov. Hardin, on the 24th of May, wisely issued a second proclamation, urging the benevolent and charitable, who might assemble on the 3d of June in public worship, and felt so disposed, to make contributions and forward the same to certain parties who would attend to the proper disbursement of the same.

Early in April, I favored the Governor with the very first copy that came from the bindery, of my Seventh Report, in which it was foretold that the locusts would begin to leave the State early in June. Whether or not this had anything to do with the date fixed upon in the proclamation, certain it is that the date was most opportune ; for the insects began to leave about that time, and that portion of the community which places faith in the efficacy

of prayer doubtless had their faith greatly strengthened by the fact.

NOT A DIVINE VISITATION.

There are those, among both the clergy and the laity, who deem a locust visitation an expression of Divine wrath, for the sin and corruption of the people—a chastisement of the Lord. They claim that the “wickedness, fraud, falsehood and corruption” which, as they assert, “abound in every department of society,” are at the bottom of it. They consider it impious to attempt to avert the evil. These opinions were boldly proclaimed in 1875 by writers in some of our prominent newspapers. The expression of such opinions is a downright insult to the hard-working, industrious and suffering farmers of the Western country, who certainly deserve no more to be thus visited by Divine wrath than the people of other parts of the State and country. Persons who promulgate such views are little removed in intelligence from the poor crack-brained negress whom I saw in the streets of Warrensburg shouting and imploring the people not to kill a locust, since God Almighty had sent them; or from the poor deluded Arabs who make no effort to destroy the locusts which they hold in superstitious reverence. It is not surprising that people are yet found who hold such views; for no great calamity ever befell a country which was not attributed, by certain fanatics, to Divine wrath; but it is surprising that, in this enlightened day, such persons can find circulation for their vagaries in the columns of some of our widely circulating and influential journals.

INFLUENCE OF THE WIND IN DETERMINING THE COURSE OF  
LOCUST SWARMS.

That excessive multiplication and hunger are the principal causes of migration from the native home of the

species, and that the prevailing winds determine the course therefrom, I have endeavored to show in Chapter III. That all these influences very largely determine the return migration when the insects hatch out in the Mississippi Valley is also doubtless true; and it is interesting to note in this connection that, according to observations, covering a period of from two to five years, furnished by General Myer, at the request of Dr. A. S. Packard, Jr.,\* the prevailing winds in May and June, within the region subject to invasion, are from the Gulf of Mexico, or from the south-east and south, *i. e.*, in exactly the opposite direction from which they blow later in the season. Yet, to assume that the migrations are solely dependent for direction on the winds would be incorrect, as there is cumulative evidence that when once the migration has commenced, adverse winds only retard, but do not materially change its course. I have known the insects in their course northwestwardly to remain on the ground for five consecutive days, the while the wind was opposing them, and then to rise and pass on as soon as it died away or blew again from the south.

#### LOCUSTS AS FOOD FOR MAN.

Our relish or disrelish of certain animals for food are very much matters of habit, or fashion; for we esteem many things to-day which our forefathers considered either poisonous or repulsive. There is nothing very attractive about such cold-blooded animals as turtles, frogs, oysters, clams, crabs, lobsters, prawns, periwinkles, snails, shrimps, mussels, quahaugs or scallops, until we have become accustomed to them; and what is there about a dish of locusts, well served up, more repulsive than about a lot of shrimps? for the former feed on green vegetation and are more

\*" The Destructive Locust of the West," *Am. Naturalist*, Vol. XI, p. 27.

cleanly than either pigs or chickens. Who can doubt but that the French during the late investment of Paris would have looked upon a swarm of these locusts as a manna-like blessing from heaven, and would have much preferred them to stewed rat? And why should the people of the West, when rendered destitute and foodless by these insects, not make the best of the circumstances, and guard against famine by utilizing them as food? Having, in 1875, personally tested them for this purpose, I will here record the result very much as originally given to the American Association for the Advancement of Science, at its meeting for that year.

In the few words I have to communicate under this head, it is not my purpose to inflict a long dissertation on edible insects. The subject has been sufficiently treated of by various authors, and especially by Kirby and Spence in their admirable Introduction to Entomology; while Mr. W. R. Gerard has brought together most of the facts in a paper entitled "Entomophagy," read before the Poughkeepsie Society of Natural History. It is my desire, rather, to demonstrate the availability of locusts as food for man, and their value, as such, whenever, as not infrequently happens, they deprive him of all other sources of nourishment.

With the exception of locusts, most other insects that have been used as food for man, are obtained in small quantities, and their use is more a matter of curiosity than of interest. They have been employed either by exceptional individuals with perverted tastes, or else as dainty tit-bits to tickle some abnormal and epicurean palate. Not so with locusts, which have, from time immemorial, formed a staple article of diet with many peoples, and are used to-day in large quantities in many parts of the globe.

Any one at all familiar with the treasures on exhibition



at the British Museum, must have noticed among its Nineveh sculptures, one in which are represented men carrying different kinds of meat to some festival, and among them some who carry long sticks to which are tied locusts—thus indicating that in those early days, represented by the sculpture, locusts were sufficiently esteemed to make part of a public feast. They are counted among the “clean meats” in Leviticus (xi, 22), and are referred to in other parts of the Bible, as food for man. In most parts of Europe, Asia and Africa, subject to locust ravages, these insects have been, and are yet, extensively used as food. Herodotus mentions a tribe of Æthiopians “which fed on locusts which came in swarms from the southern and unknown districts,” and Livingstone has made us familiar with the fact that the locust-feeding custom prevails among many African tribes. Indeed, some tribes have been called *Acridophagi*, from the almost exclusive preference they give to this diet. We have it from Pliny that locusts were in high esteem among the Parthians, and the records of their use in ancient times, as food, in Southern Europe and Asia, are abundant. This use continues in those parts of the world to the present day.

In Morocco (as I am informed by Mr. Trovey Blackmore, of London, who has spent some time in that country) they do more or less damage every year, and are used extensively for food whenever they so abound as to diminish the ordinary food-supply; while they are habitually roasted for eating and brought into Tangier and other towns by the country people and sold in the market places and on the streets. The Jews, who form a large proportion of the population, collect the females only for this purpose—having an idea that the male is unclean, but that under the body of the female there are some Hebrew characters which make them lawful food. In reality there are, under

the thorax, certain dark markings—the species used being the *Acridium perigrinum*, which is so injurious to crops. Radoszkowski, President of the Russian Entomological Society, tells me that they are also, to this day, extensively used as food in Southern Russia; while many of our North American Indian tribes, and notably the Snake and Digger Indians of California, are known to feed upon them. No further evidence need be cited to prove the present extensive use of these insects as articles of food. Let us then briefly consider the nature of this locust food, and the different methods of preparing it.

The records show us that in ancient times these insects were cooked in a variety of ways. *Ædipoda migratoria* and *Acridium perigrinum*, which are the more common devastating locusts of the “Old World,” are both of large size, and they are generally prepared by first detaching the legs and wings. The bodies are then boiled, roasted, stewed, fried or broiled. The Romans are said to have used them by carefully roasting them to a bright golden yellow. At the present day, in most parts of Africa, and especially in Russia, they are either salted or smoked like red herrings. Chenier, in his account of the Empire of Morocco (London, 1788), says that thus cured, they are brought into the market in prodigious quantities, but that they have “an oily and rancid taste, which habit only can render agreeable.” The Moors use them, to the present day, in the manner described by Jackson in his “Travels in Morocco,” viz., by first boiling and then frying them; but the Jews, in that country—more provident than the Moors—salt them and keep them for using with the dish called *Dafina*, which forms the Saturday’s dinner of the Jewish population. The dish is made by placing meat, fish, eggs, tomatoes—in fact, almost anything edible—in a jar, which is placed in the oven on Friday night, and taken out hot on

the Sabbath, so that the people get a hot meal without the sin of lighting a fire on that day. In the Abbé Godard's "*Description et Histoire de Maroc*" (Paris, 1860), he tells us that "they are placed in bags, salted, and either baked or boiled. They are then dried on the terraced roofs of the houses. Fried in oil they are not bad." Some of our Indians collect locusts by lighting fires in the direct path of the devouring swarms. In roasting, the wings and legs crisp up and are separated ; the bodies are then eaten fresh or dried in hot ashes and put away for future use. Our Digger Indians roast them, and grind or pound them to a kind of flour, which they mix with pounded acorns, or with different kinds of berries, make into cakes and dry in the sun for future use.

The species employed by the ancients were doubtless the same as those employed at the present day in the East, viz., the two already mentioned, and, to a less degree, the smaller *Caloptenus Italicus*. We have no records of any extended use of our own Rocky Mountain species (*Caloptenus spretus*), unless—which is not improbable—the species employed by the Indians on the Pacific coast should prove to be the same, or a geographical race of the same.

It had long been a desire with me to test the value of this species (*spretus*) as food, and I did not lose the opportunity to gratify that desire, which the recent locust invasions into some of the Mississippi Valley States offered. I knew well enough that the attempt would provoke to ridicule and mirth, or even disgust, the vast majority of our people, unaccustomed to anything of the sort, and associating with the word insect or "bug" everything horrid and repulsive. Yet I was governed by weightier reasons than mere curiosity ; for many a family in Kansas and Nebraska was in 1874 brought to the brink of the grave by

sheer lack of food, while the St. Louis papers reported cases of actual death from starvation in some sections of Missouri, where the insects abounded and ate up every green thing in the spring of 1875.

Whenever the occasion presented, I partook of locusts prepared in different ways, and, one day, ate of no other kind of food, and must have consumed, in one way and another, the substance of several thousand half-grown locusts. Commencing the experiments with some misgivings, and fully expecting to have to overcome disagreeable flavor, I was soon most agreeably surprised to find that the insects were quite palatable, in whatever way prepared. The flavor of the raw locust is most strong and disagreeable, but that of the cooked insects is agreeable, and sufficiently mild to be easily neutralized by anything with which they may be mixed, and to admit of easy disguise, according to taste or fancy. But the great point I would make in their favor is, that they need no elaborate preparation or seasoning, and that they really require no disguise, and herein lies their value in exceptional emergencies; for when people are driven to the point of starvation by these ravenous pests, it follows that all other food is either very scarce or unattainable. A broth, made by boiling the unfledged *Calopteni* for two hours in the proper quantity of water, and seasoned with nothing in the world but pepper and salt, is quite palatable, and can scarcely be distinguished from beef broth, though it has a slight flavor peculiar to it, and not easily described. The addition of a little butter improves it, and the flavor can, of course, be modified with mint, sage and other spices, *ad libitum*. Fried or roasted in nothing but their own oil, with the addition of a little salt, and they are by no means unpleasant eating, and have quite a nutty flavor. In fact, it is a flavor, like most peculiar and not unpleasant flavors, that

one can soon learn to get fond of. Prepared in this manner, ground and compressed, they would doubtless keep for a long time. Yet their consumption in large quantities in this form would not, I think, prove as wholesome as when made into soup or broth ; for I found the chitinous covering and the corneous parts—especially the spines on the tibiæ—dry and chippy, and somewhat irritating to the throat. This objection would not apply with the same force to the mature individuals, especially of larger species, where the heads, legs and wings are carefully separated before cooking ; and, in fact, some of the mature insects prepared in this way, then boiled and afterward stewed with a few vegetables and a little butter, pepper, salt and vinegar, made an excellent fricassee.

Lest it be presumed that these opinions result from an unnatural palate, or from mere individual taste, let me add that I took pains to get the opinions of many other persons. Indeed, I shall not soon forget the experience of my first culinary effort in this line—so fraught with fun and so forcibly illustrating the power of example in overcoming prejudice. This attempt was made at a hotel. At first it was impossible to get any assistance from the followers of the *ars coquinaria*. They could not more flatly have refused to touch, taste or handle, had it been a question of cooking vipers. Nor love nor money could induce them to do anything, and in this respect the folks of the kitchen were all alike, without distinction of color. There was no other resource but to turn cook myself, and, operations once commenced, the interest and aid of a brother naturalist and two intelligent ladies were soon enlisted. It was most amusing to note how, as the rather savory and pleasant odor went up from the cooking dishes, the expression of horror and disgust gradually vanished from the faces of the curious lookers on, and how, at last, the head cook—a stout

and jolly negress—took part in the operations ; how, when the different dishes were neatly served upon the table and were freely partaken of with evident relish and many expressions of surprise and satisfaction by the ladies and gentlemen interested, this same cook was actually induced to try them and soon grew eloquent in their favor ; how, finally, a prominent banker, as also one of the editors of the town, joined in the meal. The soup soon vanished, and banished silly prejudice ; then cakes with batter enough to hold the locusts together disappeared, and were pronounced good ; then baked locusts with or without condiments ; and when the meal was completed with dessert of baked locusts and honey *à la* John the Baptist, the opinion was unanimous that that distinguished prophet no longer deserved our sympathy, and that he had not fared badly on his diet in the wilderness. Prof. H. H. Straight, at the time connected with the Warrensburg (Mo.) Normal School, who made some experiments for me in this line, wrote: “ We boiled them rather slowly for three or four hours, seasoned the fluid with a little butter, salt and pepper, and it made an *excellent* soup, *actually*; would like to have it even in prosperous times.” Mrs. Johonnot, who was at the time an invalid, and Prof. Johonnot, the then Principal of the school, pronounced it excellent.

I sent a bushel of the scalded insects to Mr. Jno. Bonnet, one of the oldest and best known caterers of St. Louis. Master of the mysteries of the cuisine, he made a soup which was really delicious, and was so pronounced by dozens of prominent St. Louisans who tried it. Shaw, in his *Travels in Barbary* (Oxford, England, 1738), in which two pages are devoted to a description of the ravages of locusts, mentions that they are sprinkled with salt and fried, when they taste like crawfish ; and Mr. Bonnet

declared that this locust soup reminded him of nothing so much as crawfish bisque, which is so highly esteemed by connoisseurs. He also declared that he would gladly have it on his bill of fare every day if he could get the insects. His method of preparation was to boil on a brisk fire, having previously seasoned them with salt, pepper and grated nutmeg, the whole being occasionally stirred. When cooked they are pounded in a mortar with bread fried brown, or a puree of rice. They are then replaced in the saucepan and thickened to a broth by placing on a warm part of the stove, but not allowed to boil. For use, the broth is passed through a strainer and a few croutons are added. I carried a small box of fried ones with me to Europe, and they were tasted by numerous persons, including the members of the London Entomological Society and of the *Société Entomologique de France*. Without exception they were pronounced far better than was expected, and those fried in their own oil with a little salt remained good and fresh for several months; others fried in butter became slightly rancid—a fault of the butter. Mr. C. Horne, F. Z. S., writing to *Science Gossip* about swarms of locusts which visited parts of India in 1863, says: “In the evening I had asked two gentlemen to dinner and gave them a curry and croquette of locusts. They passed for Cabul shrimps, which in flavor they very much resembled, but the cook having inadvertently left a hind leg in a croquette, they were found out, to the infinite disgust of one of the party and the amusement of the other.”

This testimony as to the past and present use of locusts as human food might be multiplied almost indefinitely, and I hope I have said enough to prove that the nature of that food is by no means disagreeable. In short, not to waste time in further details, I can safely assert, from my own

personal experience, that our Rocky Mountain locust is more palatable when cooked than some animals that we already use upon our tables. I mention the species more particularly, because the flavor will doubtless differ according to the species or even according to the nature of the vegetation the insects were nourished on. I have made no chemical analysis of this locust food, but that it is highly nourishing may be gathered from the fact that all animals fed upon the insects thrive when these are abundant; and the further fact that our locust-eating Indians, and all other locust-eating people, grow fat upon them.

Locusts will hardly come into general use for food except where they are annually abundant, and our western farmers who occasionally suffer from them will not easily be brought to a due appreciation of them for this purpose. Prejudiced against them, fighting to overcome them, killing them in large quantities, until the stench from their decomposing bodies becomes at times most offensive—they find little that is attractive in the pests. For these reasons, as long as other food is attainable, the locust will be apt to be rejected by most persons. Yet the fact remains that they do make very good food. When freshly caught in large quantities, the mangled mass presents a not very appetizing appearance, and emits a rather strong and not over pleasant odor; but rinsed and scalded, they turn a brownish red, look much more inviting, and give no disagreeable smell.

The experiments here recorded have given rise to many sensational newspaper paragraphs, and I consider the matter of sufficient importance to place the actual facts on permanent record.

Like or dislike of many kinds of food is, let me repeat, very much a matter of individual taste or national custom. Every nation has some special and favorite dish which the



people of other nations will scarcely touch, while the very animal that is highly esteemed in one part of the country is not infrequently rejected in another section as poisonous. Prejudice wields a most powerful influence in all our actions. It is said that the Irish during the famine of 1857, would rather starve than eat our corn bread, but on the other hand, as we have already seen (*ante*, p. 35), the Mormons in 1855, from necessity, really subsisted on a locust diet; and if what I have here written shall, in the future, induce some of our Western people to profit by the hint, and avoid suffering or actual starvation, I shall not have written in vain.

UNNECESSARY ALARM CAUSED BY COMPARATIVELY HARMLESS SPECIES.

The sense of apprehension of further danger is great in a community that has suffered severely from any disaster whatsoever, and locusts which under ordinary circumstances would attract no attention are quite frequently looked upon with alarm and suspicion during years of visitation by *spretus*. Mr. E. W. Kruze, of Sedalia, Mo., sent me, in 1875, a very large, short-winged locust found in his locality, with an inquiry as to its name, and whether there was any connection between its appearance and the late invasion of *spretus*. The same species was also sent me from the same locality by Mr. Geo.

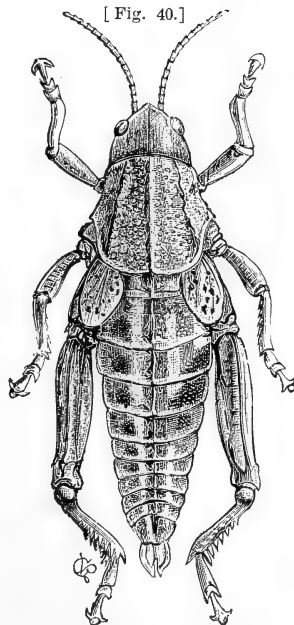

THE CLUMSY LOCUST.

Husmann. It is the *Brachyepplus magnus* of entomologists, and may be popularly called the Clumsy Locust. It is one of our largest and clumsiest species, incapable of flight, and never doing serious injury. It is common on the plains of Western Kansas and Colorado, but was never before reported from Missouri. It is prettily marked, as in Fig. 40, and occurs in two distinct varieties, one in which a bright yellowish-green prevails, and the other in which fleshy tints, and pale-brown predominate. There can be no connection between its appearance and that of *spretus*, other than that the exodus of this last rendered more conspicuous all large insects of this kind that were left behind.

Reports are often circulated and published during winter that "the grasshoppers have appeared," by which is meant that the dreaded *spretus* is about. The following letter from Dr. B. F. Dunkley, of Dunksburg, Pettis county, Mo., received in the winter of 1875-6, will show how easily people are misled :

Inclosed please find some young locusts, just hatched out. We believe them to be the Rocky Mountain Locusts, but send them to you to decide. Please answer. In my report, in answer to your circular, I said that some of the locusts that hatched out late and only grew to half the size of others that migrated and left us last July, did lay their eggs, for myself and others saw them at it. Now I think these are from the eggs laid by them. If so, will the co.d, when it comes, kill them ?

All opinions like those expressed by Mr. Dunkley are based on "mistaken identity." The species noticed hopping about, during the mild weather of January and February, are native species that are with us all the time, and habitually hibernate in the half-grown, unfledged condition. The most common of them, and that sent by Mr. Dunkley and other correspondents, is the Green-striped Locust (*Tragocephala viridifasciata*), a very common

species, ranging from Maine to Florida, and from the Atlantic to Nebraska. It passes the winter in the immature condition, sheltering in meadows and in tufts of grass, and becoming active whenever the weather is mild. It is sometimes found in winter in the early larva stages, but more often in the pupa state, and becomes fledged toward the end of April.

It differs generically from the Rocky Mountain Locust, which hibernates in the egg state. This Green-striped Locust, as its name implies, has, when mature, a broad green stripe on the front wings, and by its narrower,

[Fig. 41.]



GREEN-STRIPED LOCUST: -a, larva; b, perfect insect.

humped and keeled thorax or fore-body (Fig. 41), may at once be distinguished from the dreaded Rocky Mountain pest. Like so many other species of its family it occurs in two well marked varieties, one in which, in addition to the stripe on the front wings, the whole body and hind thighs, above, are pea-green; the other in which this color gives way to pale-brown. In both varieties the hind wings are smoky, with the basal third greenish.

The species noticed by Mr. Dunkley to hatch out late and to lay eggs in the fall, was more probably *femurrubrum* than *spretus*.

The species of the genus *Tettix* also hibernate in the half-grown and sometimes in the full-grown condition, and are frequently supposed to be the young of *spretus*. These insects are very active, and are at once distinguished by the small head, great breadth across the middle of the

prothorax which extends to a tapering point to or beyond the tip of the abdomen; by the front of the breast forming a projection like a stock-cravat into which to receive the lower part of the head, and by the short, rudimentary, scale-like front wings. They fly with a buzzing noise like a flesh-fly. Our most common species (*Tettix granulata*, Scudder, Fig. 42,) may be called the Granulated Grouse-Locust. Like the other species, it is very variable in color

[Fig. 42.]



GRANULATED GROUSE LOCUST.

and ornamentation, the prevailing hue being dark-brown beneath and paler above. A well-marked variety has a small, pale spot on the rudimentary front wings, and a larger conspicuous one on top of the hind thighs. The species of the genus *Stenobothrus* also hibernate partly grown, and are mistaken for *spretus*.

Even insects belonging to a different order are not infrequently the cause of unnecessary alarm.

In the spring of 1875 the meadows were reported as being destroyed around Champaign and Jacksonville, Illinois, by what was supposed to be the young of *spretus*; but specimens of these supposed locusts, sent me by Chapin & Simmons, of the *Jacksonville Journal*, proved to be little Jassoid leaf-hoppers allied to the common grape-leaf hoppers—insects belonging to a different order (Hemiptera) from that which includes the locusts (Orthoptera.) They were indeed *grass-hoppers*, in the sense of hopping about among the grass, but they were not the so-called grasshoppers (locusts) that at the time were proving such a plague in parts of Kansas and Missouri.

#### PROSPECTIVE INJURY.

It is of course impossible to predicate with assurance injury or non-injury from the fall swarms. There were no locusts to do harm in Manitoba in 1876, and it would

seem that the Saskatchewan country must have been more or less depleted by the swarms which overspread the country to the southeast last fall. I am inclined to hope and believe that there will not be another general invasion next autumn, and that the people of Texas, Indian Territory, Arkansas, Missouri, Kansas, Nebraska, Iowa, Southern Dakota and even Minnesota, may expect immunity for a few years to come, after the hosts which hatched this spring are destroyed, or wing themselves away. There may be partial injury from their progeny in 1878, or even 1879, in parts of the country named, especially toward the Northwest, but there will, I think, be no general destruction.

That in the future the States just enumerated will be again visited from time to time, there can be no manner of doubt, unless the Commission now investigating the subject discover some means of preventing the migrations of the pest from its native breeding-grounds. But the injury will decrease in proportion as the population increases—as knowledge and experience with the insect are acquired and retained—and as the Signal Service is able to forewarn the farmer of approaching swarms. It is my earnest hope that this little treatise, which I now close, will, in serving as a record of the past, if in nothing else, prove valuable to the farmers of the West, by helping them to successfully withstand any future visitation of *Caloptenus spretus*.

## ERRATA.

---

PAGE 44, last line, for “;” read “and.”

PAGE 92. As I learn from Prof. Asa Gray, the *Amarantus* here referred to as *Blitum*, and hitherto so considered by botanists, is, according to Mr. Watson, a new species. It is common in the Rocky Mountain regions, and has certainly spread from the West; whereas the *Blitum*, introduced from Europe, has doubtless spread from the East.

PAGE 112, line 7, after “Sphinx,” add “(*Deilephila lineata*).”

# INDEX.

<b>A</b>	
Air, effects of exposure to, on eggs of <i>spretus</i> .....	148
<i>Acridium Americanum</i> .....	101
"    "    flight of, mis-	
taken for <i>spretus</i> . .....	31
<i>Acridium perigrinum</i> .....	205
<i>Amarantus Blitum</i> .....	92, 110
American Acridium .....	101
Amaron, use of .....	77
<i>Amblychila cylindriformis</i> .....	127
Anonymous Tachina-fly .....	131
Anthomyia Egg Parasite .....	118
<i>Anthomyia radicum</i> .....	118
"    "    var. <i>calopteni</i> , .....	118
" <i>brassicæ</i> .....	121
" <i>ceparum</i> .....	121
" <i>raphani</i> .....	121
<i>Apocynum</i> .....	92
<i>Aristida oligostachia</i> .....	110
<i>Asclepias</i> .....	92
<i>Astoma gryllaria</i> .....	128
" <i>parasiticum</i> .....	130
Atlantic Locust .....	22
<b>B</b>	
Beetles that prey on locusts .....	127
Birds, enemies of locusts .....	113
Bird-laws should be enforced .....	139
Birds should be protected .....	169
Bounty law, desirable features of ..	185
Box Turtle, eats locusts .....	114
<i>Brachyepelus magnus</i> .....	228
Breeding places of <i>spretus</i> .....	56
Burning machines .....	156
Burning the young locusts .....	155
Burying locust-eggs, effects of .....	149
<b>C</b>	
<i>Caloptenus Atlanis</i> .....	22
" <i>bi-vittatus</i> .....	89, 194
" <i>differentialis</i> .....	89, 194
" <i>femur-rubrum</i> , full de-	
scription of .....	15
<i>Caloptenus</i> , peculiar characters of	
the genus .....	15
<i>Caloptenus Italicus</i> .....	31, 221
<i>Caloptenus spretus</i> , detailed de-	
scription of .....	17
<i>Caloptenus viridis</i> .....	27
<i>Calosoma calidum</i> .....	127
Carabidæ, larvæ of certain, devour	
eggs of locust .....	124
Cat Bird .....	114
Catching locusts .....	161
Chalcid fly, parasitic on <i>spretus</i> ..	117
Changes that follow locust inva-	
sions .....	109
<i>Cicindela</i> , species that prey on	
<i>spretus</i> .....	128
Classificatory position of <i>spretus</i> ..	13
Climatic peculiarities of Western	
plains .....	56
Clumsy locust .....	227
Coal-oil pans, how constructed .....	163
<i>Coccygus Americanus</i> .....	114
Collecting locust-eggs .....	153
Comparative description of immat-	
ure stages of <i>spretus</i> , <i>femur-</i>	
<i>rubrum</i> and <i>Atlanis</i> .....	26
Comparison of Red-legged Locust	
and Rocky Mountain Locust .....	14
Compensation attending locust in-	
juries .....	108
Contrivances for catching young	
locusts .....	162
Coral-winged locust .....	102
Cotton batting, use of, in protect-	
ing trees .....	166
Country in which <i>spretus</i> can not	
permanently thrive .....	203
<i>Crabro stirpicola</i> .....	122
Crow Blackbird .....	114
Crushing young locusts .....	157
<b>D</b>	
Damage done by common locusts ..	206
Dawson, G. M., his observations on	
return migrations of <i>spretus</i> .....	48
<i>Deilephila lineata</i> .....	112
Destination of departing swarms of	
<i>spretus</i> .....	104
Destruction of young locusts .....	155
Destructiveness of <i>spretus</i> .....	89
Development of migrating instinct ..	200
Differential locust .....	194

- Direction in which young locusts travel..... 100
- Direction taken by departing swarms of *spretus*..... 103
- Distinguishing characters of Rocky Mountain Locust and Red-legged Locust..... 15
- Ditch for trap, size important..... 160
- Ditching and trenching as safeguards against *spretus*..... 157
- Diversified agriculture desirable... 174
- E**
- Early visitations of Rocky Mountain Locust..... 33
- Eastern limit of locust invasions, 53, 203
- Effects of young of *spretus*, where hatched ..... 107
- Egg-mass of *spretus*, construction of..... 71
- Egg-masses of *spretus*, how many formed by one female ..... 72
- Eggs of *spretus*, how laid ..... 69
- “ “ where laid ..... 96
- “ “ when hatched.... 97
- “ “ experiments with, 140
- “ “ methods of destroying ..... 139
- Egg-parasites of *spretus*..... 117
- Eggs of Silky Mite..... 116
- Embryon of *spretus*, growth and appearance of..... 74
- Eragrostis poaeoides*..... 110
- Erax bastardi*..... 128
- Escape of *spretus* from egg..... 73
- Exorista flavicauda*..... 134
- Experiments with eggs—
- Burying ..... 149
- Exposure to air..... 148
- Freezing and thawing..... 141
- Soaking and drying..... 143
- F**
- Fall harrowing..... 153
- Famine and epidemics consequent on locust invasions..... 30
- Fasting and prayer..... 213
- Femur-rubrum*, destructiveness of, in 1869..... 38
- Field Mouse, eats locust-eggs ..... 111
- Flesh-fly..... 123, 135
- Flight of *spretus*, direction of..... 96
- “ “ extent of..... 85
- Flight of *spretus*, noise of..... 57
- “ “ sometimes nocturnal ..... 83
- Food plants of *spretus*..... 89
- Freezing and thawing eggs of *spretus* ..... 141
- Fruit trees, how protected..... 165
- “ “ injuries to ..... 93
- G**
- Gordius aquaticus*..... 114
- Granulated grouse-locust..... 230
- Grasshopper vs. locust..... 207
- Great-crested Fly-catcher..... 114
- Green-striped locust..... 229
- Green variety of Rocky Mountain locust ..... 27
- H**
- Habits of young of *spretus*..... 98
- Hard soil, why preferred for purpose of oviposition..... 77
- Harpalus*, larvæ of, devour eggs of *spretus* ..... 125, 126
- Harrowing locust-eggs..... 153
- Harpalus Pennsylvanicus* ..... 127
- History of locust ravages in America..... 33
- Hogs as destroyers of locusts. .... 171
- Hymenopterous larva, parasitic on eggs of Rocky Mountain Locust. 123
- I**
- Ichneumons, probably parasitic on locusts ..... 128
- Imago of *spretus*, flexibility of newly developed legs of..... 81
- Influence of moisture on locust-eggs..... 143
- Intervals of oviposition..... 73
- Invasion of 1818-19..... 33
- “ 1845-49..... 34
- “ 1855-72..... 34-38
- “ 1874..... 39
- “ 1875..... 42
- “ 1876..... 49
- Invertebrate locust enemies..... 115
- Irrigation ..... 154, 171
- J**
- Joel the prophet's description of locust fligh s..... 87
- K**
- Kansas locust-laws..... 178, 179
- Kerosene, use of, as a locust-destroyer..... 162



- Kings or Queens, locusts not led by ..... 101
- L**
- Lachnosterna fusca*..... 126  
 Lapland Longspur..... 113  
 Larvæ of Morning Sphinx..... 110, 111  
 Larva of *Anthomyia*, description of 120  
 Larvæ of Tachina-flies and flesh-flies compared..... 136  
 Larva of *spretus*, full description of 20  
 Late planting desirable..... 170  
 Legislation on locusts..... 176  
*Leptus irritans*..... 130  
 Limit of locust migrations..... 60  
 Locust Mite..... 128  
 Locust plague no new thing..... 29  
 Locust ravages east of Mississippi, 190  
 " " how to prevent..... 139  
 Locust vs. Grasshopper..... 207  
 Locusts, alarm caused by harmless species of..... 227  
 Locusts as food for man..... 217  
 Locusts, flights of, east of the Mississippi..... 201  
 Locusts, flights of, in Illinois in 1875..... 195  
 Locusts, flights of, in Illinois in 1875, composed mainly of *Allanis* 198  
 Locusts in America, earliest record of..... 31  
 Locusts in South America..... 32  
 Locusts not a divine visitation..... 216  
 Locusts on Pacific coast, early records of..... 32
- M**
- Mantis Carolina*, feeds on locusts, 128  
 Measurements of *femur-rubrum*... 17  
 Measurements of locusts, how taken..... 16  
 Measurements of *spretus*..... 21  
*Melanerpes erythrocephalus*..... 114  
*Melanoplus* or *Caloptenus*..... 209  
*Mermis*..... 114  
 Migrations of locusts, cause of... 57, 200  
 " " influence of  
 wind in determining..... 57, 104, 216  
 Migratory instinct of locusts..... 88  
 Migratory locust of Europe, destructiveness of..... 30  
 Migratory locusts in Atlantic States..... 187
- Military, employment of, against locusts..... 173  
*Mimus Carolinensis*..... 114  
 Minnesota locust-law..... 180  
 Missouri locust-law..... 177  
 Modification of species..... 63  
 Molting process..... 79  
 Molts, number of, in *spretus*..... 82  
 Morning Sphinx..... 112  
*Myiarchus crinitus*..... 114
- N**
- Native home of *spretus*..... 61  
 Natural enemies of *spretus*..... 113  
 Natural history of *spretus*..... 69  
 Nebraska locust-law..... 185  
 Ninety-fourth meridian, eastern limit of *spretus*..... 65  
 Nomenclature..... 207  
 Non-migratory locusts, injury from..... 190  
 Non-migratory locusts, unusually numerous some years..... 199  
 Number of eggs deposited by *spretus*..... 70
- O**
- Oedipoda atrox*..... 89  
 " *migratoria*..... 31  
 " *phœnicoptera*..... 102  
 Omaha Conference..... 53  
 Omnivorous propensities of locusts 91  
 Origin of migratory locusts..... 57  
 Oviposition of locusts..... 69
- P**
- Panicum sanguinale*..... 110  
 Parasite of house-fly..... 130  
 Paris Green, use of, for destroying locusts..... 164, 170  
*Pasimachus elongatus*..... 127  
 Pennsylvania ground-beetle..... 127  
 Perpetuation and permanent settlement of *spretus* east of 94th meridian impossible..... 62  
 Plants uninjured by locusts..... 44, 170  
*Plectrophanes lapponicus*..... 113  
 Ploughing the eggs under..... 153  
 Poultry destroy locusts..... 171  
 Power of locusts for injury..... 85  
 Practical considerations..... 139  
 Prairie fires useful in spring..... 169  
 Prairie fires vs. locust ravages..... 209  
 Predictions as to probable injuries from locusts in 1875..... 41

- Preventive measures ..... 169  
 Proclamation of Gov. Hardin..... 213  
*Promachus apivora*..... 127  
 Prospective injury from locusts... 230  
 Pupa of *spretus*, description of... 20  
 Purslane, great abundance follows locust injury ..... 111
- Q**
- Quiscalus versicolor*..... 114
- R**
- Rains, advantage of heavy..... 43  
 Rate of flight of locusts..... 56  
 Rate of flight of locusts, variable.. 96  
 Rate of spread..... 95  
 Rate of travel of young..... 100  
 Ravages of locusts east of Mississippi ..... 187  
 Red-eyed Vireo..... 114  
 Red-headed Woodpecker..... 113  
 Red-legged locust common in United States..... 14  
 Remedies against locusts..... 139  
 Results arrived at by experiments on eggs of locusts..... 151  
 Return migration to British America..... 47  
 Return migration to British America, theory of, strengthened by occurrences in 1876..... 50, 51  
 Rocky Mountain Locust purely American..... 28  
 Root crops, what ones safe..... 175
- S**
- Salvia trichostemmoides* ..... 92  
*Sarcophaga carnaria*..... 123, 135  
 " *sarracenia*..... 132  
 Side ditches and drains as traps for locusts..... 160  
 Signal Service, availability of, in communicating information as to locust invasions..... 172  
 Silky Mite..... 115  
 Skunk, enemy of *spretus*..... 114  
 Smudging and smoking..... 168  
 Soldier-bug, feeds on locusts..... 128  
 Species, geographical range of.... 202  
 Species, failure of people to discriminate between..... 204  
 Species, variation in..... 25
- Species *vs.* Variety and Race ..... 23  
 Species, what constitutes a..... 24  
 Specific distinctions arbitrary.... 25  
 Spines on legs of locusts, possible use of..... 76  
*Spretus* and *Allanis* probable races of *femur-rubrum* ..... 26  
 Starvation caused by locust invasions—cases of, not well attested. 46  
*Stenopogon consanguineus* ..... 127  
 Striped Squirrel, eats locust-eggs.. 114  
 Summer *vs.* Fall swarms..... 58  
 Sulphur, use of, in protecting trees 167
- T**
- Tachina anonyma*..... 131  
 " *flavicauda* ..... 134  
 Temperature at St. Louis in winter of 1876-7, table of..... 152  
 Tendency of hatching locusts to push upwards..... 78  
*Tettix granulata*..... 230  
 Texas, early locust invasion of.... 34  
 Time of appearance of invading swarms ..... 94  
 Time of hatching of eggs ..... 97  
 Tin, use of, in protecting trees ..... 166  
*Tragocephala viridifasciata*..... 228  
 Tramping ground infested with locust-eggs ..... 154  
 Transformations of *spretus*..... 69  
 Trapping young locusts..... 157  
 Trees, what usually avoided by *spretus* ..... 91  
*Trombidium scabrum* ..... 115  
 " *sericeum*..... 115  
 " *holocericeum* ..... 115  
 Two-striped locust..... 194
- V**
- Vernonia novaboracensis* ..... 92  
*Vilfa vaginaeflora* ..... 111
- W**
- Water, efficacy of, in ditches for trapping locusts..... 160  
 White-lined Morning Sphinx..... 112  
 Wind, its influence in determining course of locust swarms...57, 104, 217
- Y**
- Yellow-tailed Tachina-fly..... 134  
 Yellow-billed Cuckoo..... 114  
 Young locusts, how destroyed..... 155

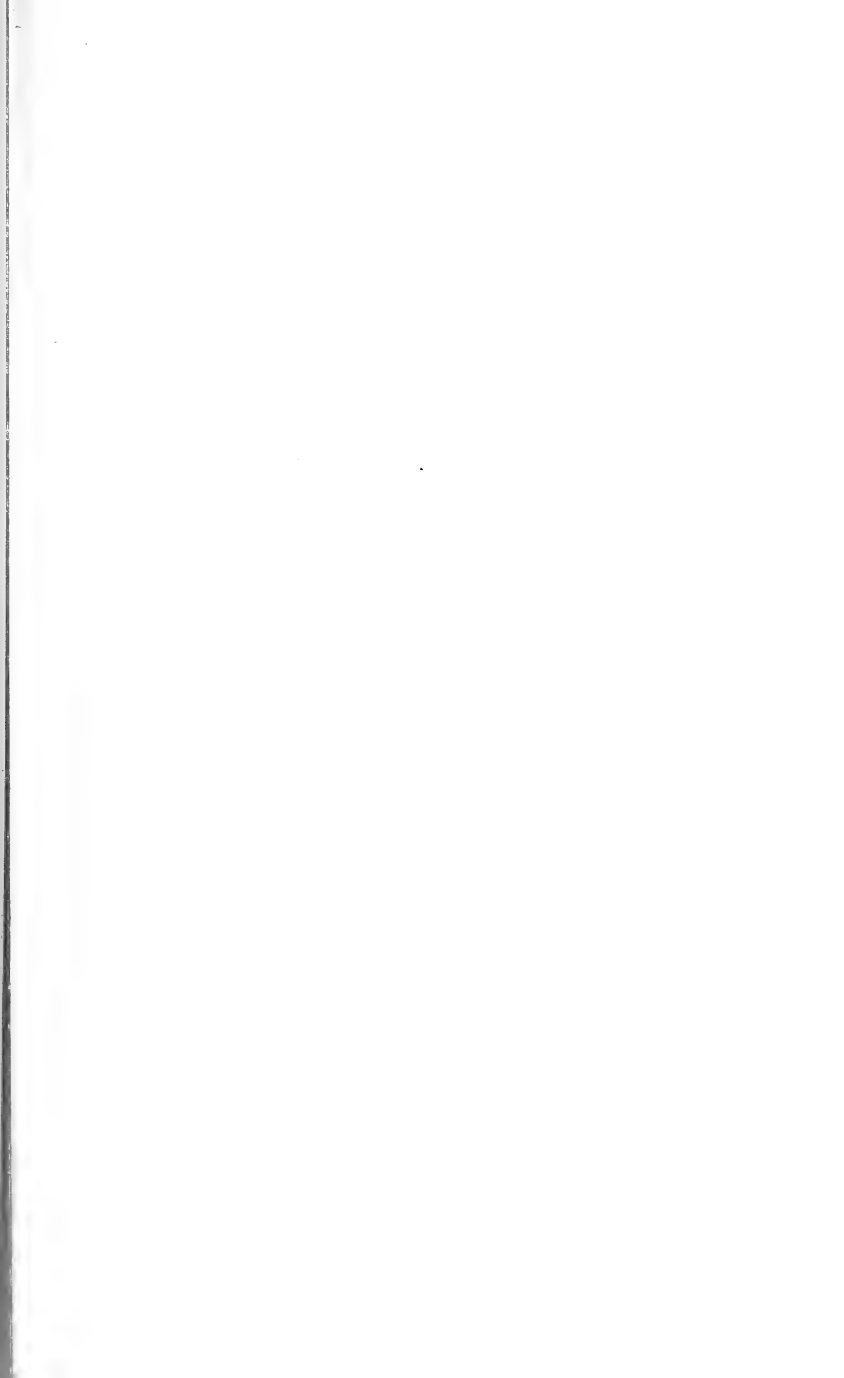



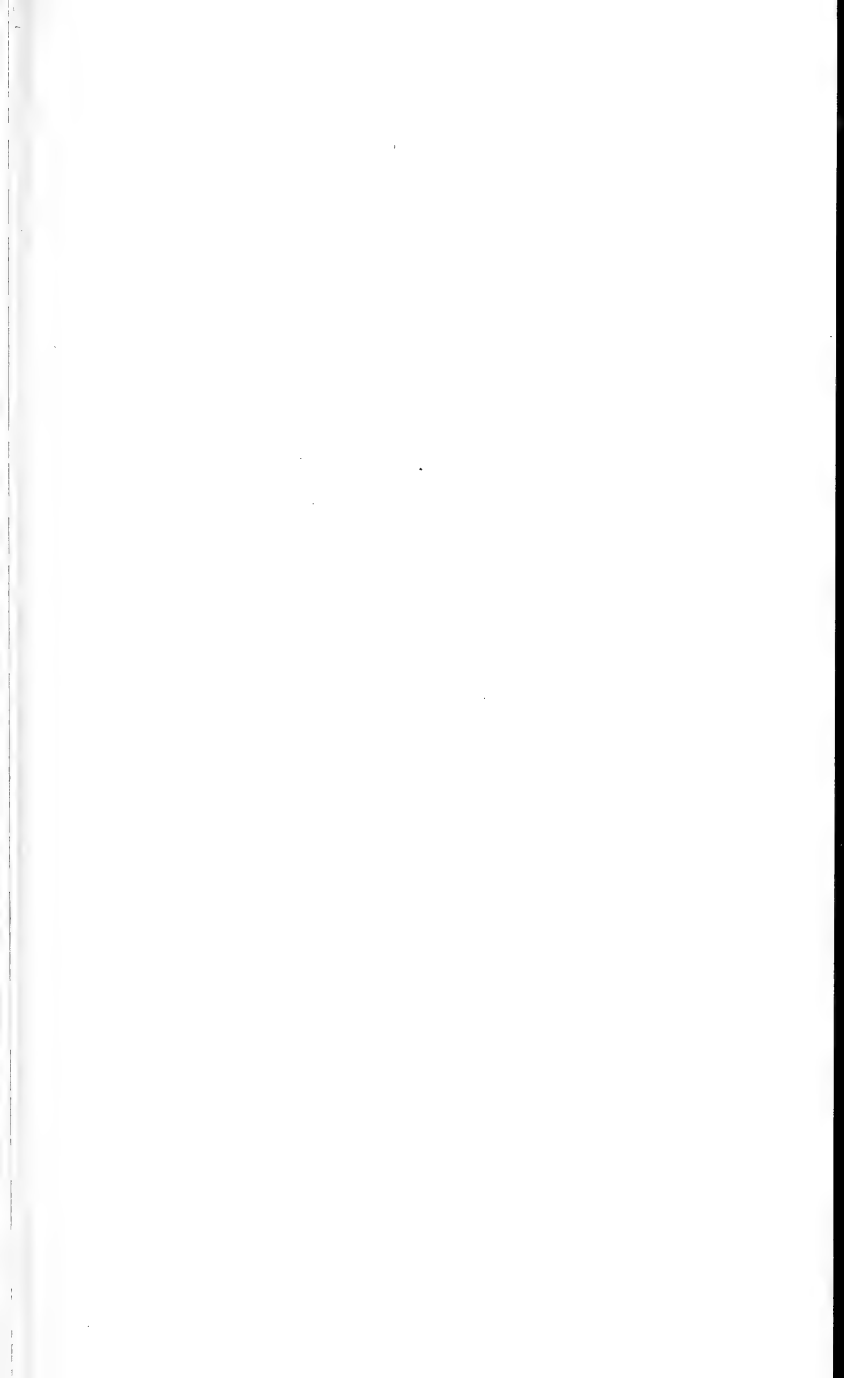



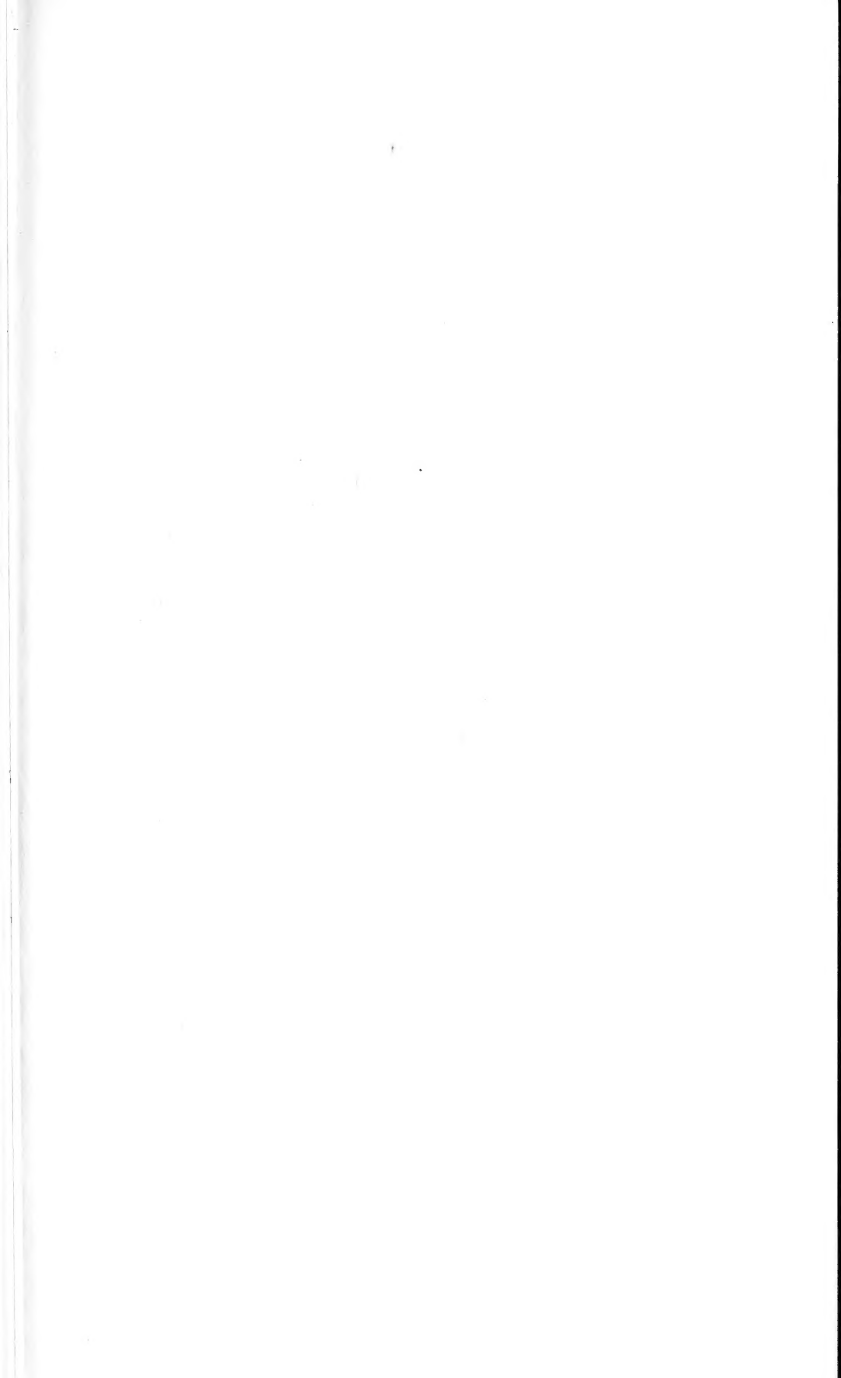

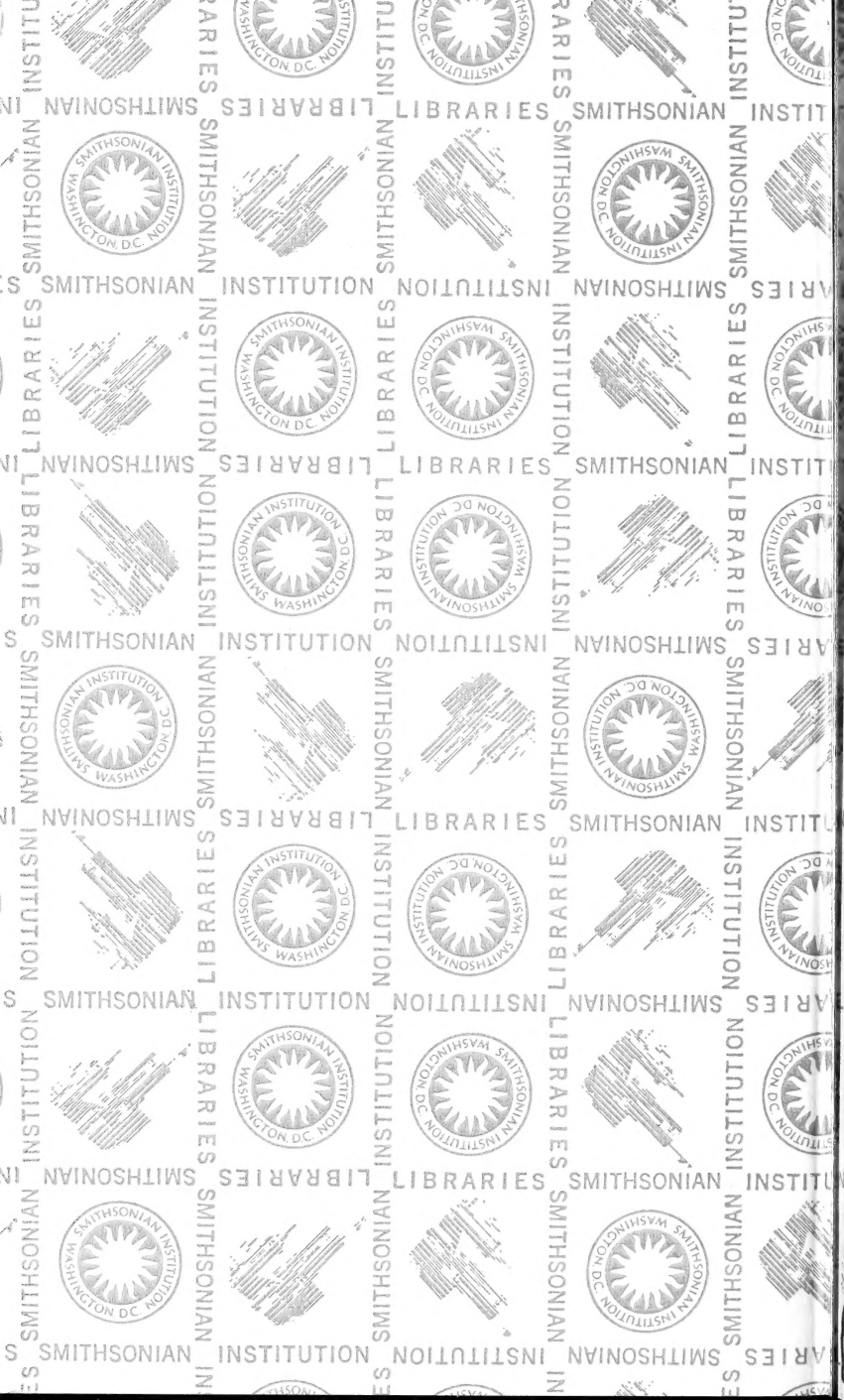



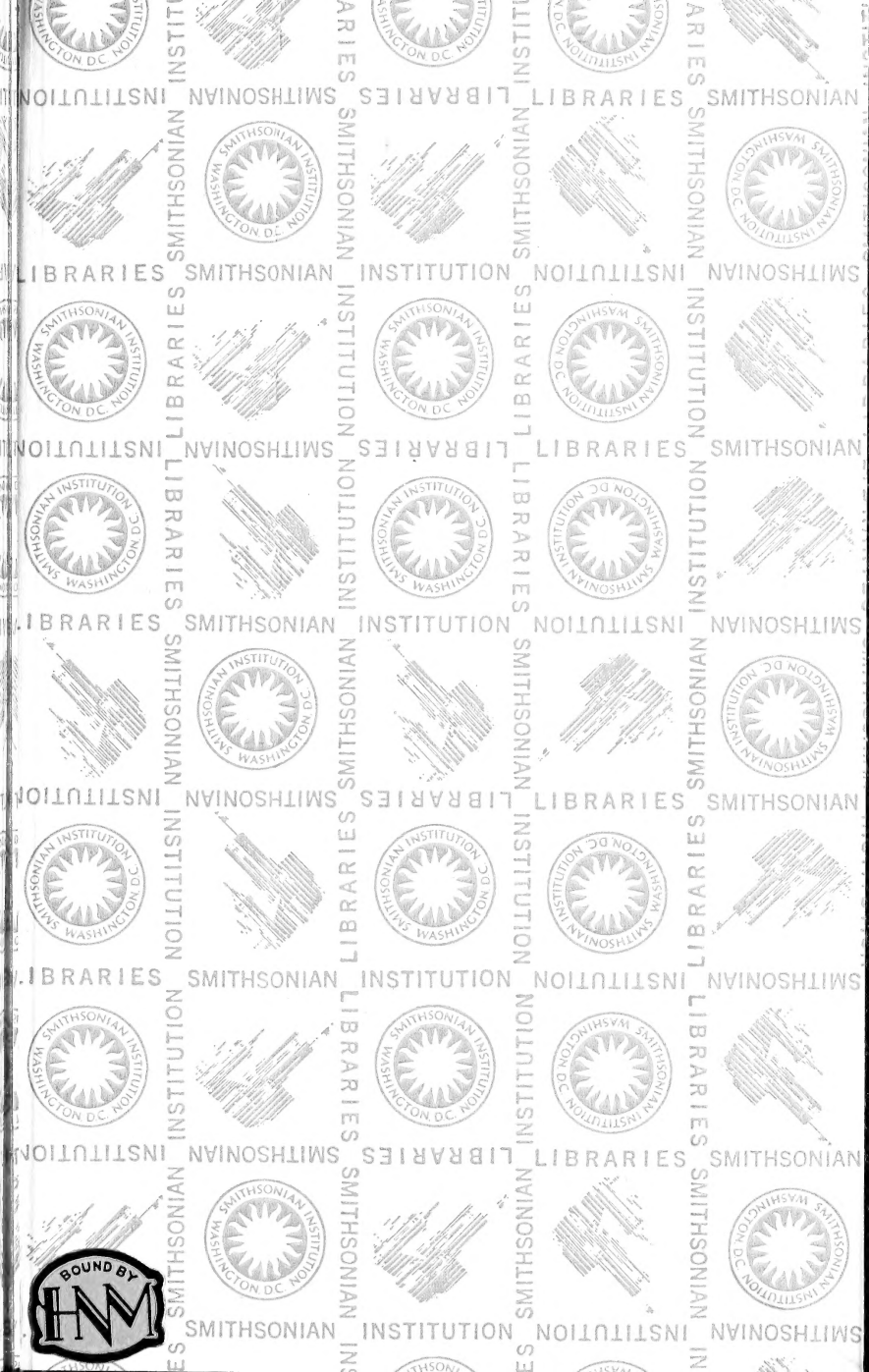

SMITHSONIAN INSTITUTION LIBRARIES



3 9088 00268344 9

nhent SB945.R7R57

The locust plague in the United States: