

S 534

.T2 M2

S 534
.T2 M2
Copy 1

A Manual for High Schools

With Special Reference to SCIENCE and AGRICULTURE

BY

JOSIAH MAIN

Department of Agricultural Education, University of Tennessee

[Copyright 1908 by Josiah Main. All Rights Reserved.]

A MANUAL FOR HIGH SCHOOLS

With Special Reference to Science and Agriculture

I. Point of View.

Order is heaven's first law and this manual is an attempt to give the appearance of order, to a matter that is more or less confused in school men's minds. In recent years the course of study for the high has been carefully worked out and agreed upon and in its approved form is either the working plan or the ideal of standard high schools. Such course includes a generous amount of work in physics, chemistry, physical geography, botany, zoology and physiology. Since the best method of illustrating any unknown fact or principle is by means of familiar materials and since to a vast majority of pupils these for the sciences mean agricultural materials economy dictates the use of what the rural environment affords in teaching all sciences, and no science should be attempted that cannot be demonstrated by some means; or stated conversely from the industrial viewpoint, since agriculture depends on a knowledge of all the sciences the only way to put agricultural instruction on a safe, rational basis is to correlate it with the underlying sciences and teach both together without attempting to draw any very sharp line to indicate when we pass from the cultural to the industrial use. Granted that scientific subjects *where as well taught* have a cultural value not inferior to other subjects in the curriculum and that therefore they should be as liberally provided for, and granted further that a reform in education in the interest of industrial vocations is imminent, how may schools most economically meet the two requirements? Here the school man is hesitating while the advocates of industrial education are not. The writer as a school man of some variety and length of experience insists that if

education is to be reformed "the revision should be by its friends" that we may be saved the expense of a dual system of public education and that the ancient landmarks of pedagogy be preserved. And in the present situation it is hard to tell which is worse, the fellow who sees nothing but agriculture or the fellow who will have none of it.

An argument for the introduction of agricultural courses into all secondary schools (high schools) maintained by taxation of an agricultural public should not be necessary and is not here attempted. This manual is intended to set forth a method by which the high school may not only provide agricultural instruction to prospective farmers, teachers of rural schools, and preparatory students for whatever course or vocation, but also to show how the correlation of such agricultural work with the high school science work may *immeasurably enhance the value of both*. In the course of study following the idea of utilizing agriculture for the foregoing purposes is worked out and the order in which various sciences are arranged and developed in the course is not only an approved scientific and pedagogical order but will also be found to satisfy the order imposed by the succession of seasons. For there is a tide in the affairs of the farm home which the agricultural teacher should take at the flood, launching his topics at the right psychological moment to attain the maximum of interest and to affect most profitably the succeeding crop.

Whether the college or university endorses a plan of education that is successful locally is a matter of small concern to the school since so few of its students are destined to go farther than the home school. The high school is the people's college and any warping of its course merely to satisfy college entrance requirements indicates a misconception of the function of the public school system. However there should be no war here as the universities stand for this same idea of education and will meet any school that provides the proper amount of thorough profitable work on any subject. The high school is less dependent on maintenance of accredited relationship than the college or university is.

An examination of the agricultural topics enumerated in this course of study should convince one that like all other subjects taught in the high school the only safe preparation for the teacher is collegiate training; and very much of the work now from necessity presented only in the agricultural colleges is no more than secondary in grade and is destined to be removed to the high schools as soon as they put themselves in the proper attitude to receive it. For such services the best high schools will, as they now do in the case of other instructors, pay more than the college or university pays its instructors which because of their

scarcity is also more in the case of agriculturists than of other expert teachers of equivalent attainments.

The problem of giving agricultural instruction in high schools is one of preparation of the teacher, of cooperation of the community and of providing the funds. The board should therefore expect to provide more means and know what the additional expense is to be before installing the course. What that additional expense is to be depends upon the plans of the school, the extent to which the community is willing to cooperate, and the ability of the agriculturist to get the most out of his equipment and environment.

The ultimate aim of agricultural education has not always been clearly defined. To many of its strongest advocates and the industrial masses generally it means greater efficiency in the work by which they maintain themselves and their families, and an alleviation of hardships. Praiseworthy though these motives may be, to the writer it means much more as an educational reform than it does as an industrial reform simply, a statement of reasons for which belief would be argumentative and are therefore omitted. But that belief explains the point of view and for that reason is mentioned. As an educational reform its origin is the universities and its destination the high school in which many of the influential citizens of the future are to get their final training and the rural schools of which none are too humble or too poor to have the benefit. And as the only practicable route by which the rural schools may get the benefits of the reform is by way of the high school of which every county is destined to have one or more, the high school should be made the rural teachers' training school. The high school should therefore send its students in three directions—to active life, to the college, and to the rural school.

The subject of agriculture should be incorporated into the science work of the high school and not superimposed upon the already crowded high school course—a mistake that has been made often enough that it should begin to be apparent to the friends of agricultural education. And for this purpose only the "principles" of agriculture (or any other vocation) have a right to a place in the course. That all principles of agriculture are scientific principles and as such are the most familiar and available for cultural use is here asserted and in the accompanying course of study clearly illustrated. Courses of study providing specifically methods and practices in the economies of cultivation of particular crops, harvesting, preservation, breed peculiarities, care of herds—all being matters of information and skill in the vocation of agriculture have no more place in a general high school course than have the methods and technical phases of commerce, telegraphy, music, photography, pharmacy, assaying or a multitude of other subjects which the high school course deals with theoretically but without aiming to turn out skilled operators. The advocates of agri-

cultural education in the high school should be satisfied to have accurate instruction given in the general principles of the vocation to such extent that the pupil will have both incentive and ability to master the details in his own peculiar way. Such instruction should not be merely general information but should be technical in a sense but it should be the technique of science and not the technique of agriculture. To demand more than this will be to destroy the value of the course for general class uses, to arouse the just opposition of school men (whose jealousy of educational principles involved is even now very apparent) and to injure and delay the cause.

The scientific principles involved in agriculture are limited in number and quite definite in character. But there is no limit in theory nor in fact to agricultural methods and practices. And these latter in a high school course of study have no value to the large majority of students who should understand the principles. The high school cannot hope to produce operatives as well prepared for immediate employment as can the business colleges and the training and industrial schools though it does give all the training for a far greater success in those callings than can any short course of concentrated effort. And the reasons for this are deep seated and involve the psychology of adolescence. Agreeable to these reasons the proper relation of the high school to vocation is as a means of discovering natural talent for the vocations by giving as wide a field for the pupils' preference as possible. Beyond this amount of instruction the teacher of agriculture can quite properly devote such time as he can spare to instruction of those pupils who have elected agriculture as a vocation in the best agricultural practices but this latter purpose should always be secondary.

II. Course of Study.

The amount of work suggested here is pretty close to the upper limit. The amount of work the school may accomplish depends not only on how many topics are touched upon but also on what the teacher is able to make them mean. Any person of agricultural experience is well aware that it is of such a nature as to admit of neither definite apportionment in amount nor location in time. Nevertheless the aim should be high and a complete plan kept in mind in order to induce and measure progress from year to year and to properly apportion effort between subjects.

No attempt is made in this course of study to develop other topics than the agriculture and its related sciences because such other topics have been exhaustively discussed and expanded and because this is a high school manual of agriculture. Its purpose is to enable the school man to take his bearings. But it cannot at best be a substitute for technical training in agriculture on the part of the teacher. The problem is not to be solved by a formula.

Explanations:

Bul. means Farmers' Bulletin.

O. E. S. means Bulletin of the Office of Experiment Stations.

Year Book means Year Book of the Department of Agriculture.

Stat. means Bulletin of the Experiment Station of the state where the school is.

Prob. means problem.

Excurs. means excursion.

Micros. means microscope.

Lab. means laboratory.

A unit consists of 36 weeks' work with daily recitations of 40 minutes each five times per week. Two laboratory or excursion periods are equivalent to one recitation period. Value of irregular work should be estimated on this basis.

Reading assignments and text books are printed in italics.

Courses;

Preparatory and general

Literary..... L.

Scientific..... S.

Engineering..... E.

Teachers..... T.

Industrial..... I.

Short courses in Agriculture

Groups;

	Subjects				For whom prescribed				
	11	21	31	41	L	S	E	T	I
English					L				
Foreign Language	12	22			L				
			32	42					
Sociology	13	23	33	43				T	I
Mathematics	14	24			L	S	E	T	I
			34	44			E		
Science	15	25	35-6			S	E	T	I
			45			S		T	I
Pedagogics, supplied by Co. Supt.								T	
No. units (years) prescribed	8	11	12	15 ⁺	15				
No. electives	7	4	3	0	0				
Required for graduation	15	15	15	15	15				

Subjects by Years	SCIENCE in detail (three Periods per week)
I	
11 English	FALL Mechanics of liquids, Pascal's law, capillarity. Properties and states of matter. Force: composition and resolution, moment, Specific gravity <i>Tarr or Davit, Phys. Gen.; Earth, Sea.</i>
12 Foreign Lang.	WINTER Mechanics of gases, Boyle's law, barometer. Heat, thermometer. Meteorology. <i>T. or D.; Atmosphere.</i>
13 National Gov't ½ Accounts ½	SPRING Structure of earth's crust, collection of minerals. Weathering, frost action. Local topography, stream action. Mechanical principles. <i>T. or D. Plains, Mountains, Rivers.</i> (excurs.)
14 Algebra	
15 Elementary Phys- ics and Phys. Geog	
II	
21 English	FALL Structure and function of flower. Analysis and classification. Ready recognition of 12 families. Fruits and fruiting habits. <i>Leavitt and Cras; Flower and Ker.</i>
22 Foreign Lang.	WINTER Morphology and function of root, stem and leaf. <i>Leavitt.</i>
23 Ancient Hist.	SPRING Physiology: germination and nutrition. Seed structure. <i>Osterhout,</i>
24 Plane Geom.	
25 Botany	
III	
31 English	FALL Insects; structure, development. Elementary chem. collecting and classifying lab. guide. <i>Snyder.</i>
32 Foreign Lang.	" by orders.
33 Civics ½ Economics ½	" relation to plants. <i>Herrick</i>
34 Algebra ½ Geom. ½	WINTER Protozoa, bacteria, yeasts, fungi, lab. guide. Cell structure and division. Chemical processes in arts and industries. <i>Cann, Herrick, Snyder.</i>
35 Biology and Invert Zoology	(micros)
First half 3 periods Second half 5 periods	SPRING Other invertebrate types. Organic chemistry Parasitism. elementary. <i>Snyder</i> Systematic zoology. (micros.) <i>Herrick</i>
36 Chemistry	
First half 5 periods Second half 3 periods	
IV	
41 English	FALL Animal tissues. (micros.) Skeleton of man and of other vertebrates. Muscles of man. <i>Eddy.</i>
42 Foreign Lang.	WINTER Lab. dissection of rabbit, pigeon, turtle, frog, fish. Comparison of structure; musculature, digestive, circulatory, excretory and reproductive systems. Lower chordates, systematic zoology. <i>Herrick</i>
43 European Hist.	SPRING Variation and natural selection. Brain, nerves and special sense organs. Geological and geographical distribution. Hygiene. <i>Eddy</i>
44 Physics	
45 Physiology and Vert. Zool.	

Suggestions:

Engineering prep. students may be excused from the agricultural phase of 25 and 45. Where the school provides manual training it should there be given in lieu of the agriculture.

Girls in Science course may be excused from the agricultural phase of Science course as follows: 15 spring, 25 spring, 45 fall and spring. Where the school provides domestic science work it should be taken in lieu of agriculture in those terms.

Pupils in Teachers' and Industrial courses should take as much of the manual training as their schedules will permit.

Correlated with AGRICULTURE (two double Periods per week)

Moisture control, mulches, field samples.	O. E. S. 186
Soil experiments in laboratory.	
Physical analysis and classification.	
Drainage methods (excurs.)	<i>Davis; Agriculture</i>
Soils of state.	<i>Bul. 266</i>
Physiographic regions of U. S.	<i>Year book</i>
Daily weather map.	<i>Stat.</i>
Climate and physiography as related to agriculture.	
<hr/>	
Local soil areas, collection.	
Soil temperature as related to drainage, color, slope, texture, depth.	
Control of texture, Implements of cultivation. (excurs.)	<i>Davis</i>
<hr/>	
Economic representatives of 12 families of plants.	<i>Bul. 86</i>
Fruiting habits of plants, (useful and injurious)	<i>Grav; Botany</i>
Seed collecting. (excurs.)	
<hr/>	
Cereal judging.	<i>Buls. 134, 154, 157, 161</i>
Crop statistics.	<i>181, 185, 260</i>
Special articles.	<i>O. E. S. 186.</i>
Budding and grafting. Propagation.	<i>Year book</i>
Pruning and spraying. (excurs.)	<i>Bul. 195, 218, 253, 255</i>
Seed and seed control.	
Viability tests.	<i>Stat.</i>
School plots. (breeding, desirable introductions)	<i>O. E. S. 186</i>
<hr/>	
Injurious insects, nature of damages.	<i>Bul. 47, 127, 132, 134</i>
Life history, repression.	<i>155</i>
Collection and preservation. (excurs.)	<i>Stat.</i>
<hr/>	
Germ diseases of plants and animals, repression.	<i>Bul. 192, 203, 245, 256, 278</i>
Useful bacteria and yeasts; in arts, in agriculture, inoculation.	<i>O. E. S. 195</i>
Composition of soil and of plant foods; pot demonstrations.	
Composition of 50 common substances, foods, fertilizers, and reagents.	
<hr/>	
Relation of soil texture to fertility.	<i>Buls. 112; 121, 247</i>
Fertilizers and manures (probs.) collections.	
Plotwork in fertilizers and legumes. (through vacation)	
Foods and nutrition.	<i>Vivian</i>
Collections	
<hr/>	
County fair.	<i>Bul. 22, 66, 71, 147</i>
Grasses and forage.	
Feeding farm animals. (probs.)	
Swine, sheep and beef judging. (excurs.)	<i>Craig</i>
<hr/>	
Farm butchering.	<i>Bul. 34, 42, 51, 55, 63</i>
Meat; value and location of cuts.	<i>106, 179, 183, 287</i>
Milk; composition and testing.	
Poultry. (excurs.)	<i>Van Norman</i>
<hr/>	
Horse and dairy cattle judging.	<i>Bul. 95, 126, 187, 235, 270</i>
Improvement of plants and animals by selection.	
Mapping local farms.	
Farm buildings and equipment; estimates, problems.	
Farm management; rotation, diversification and specialization.	

Pedagogics should be provided for specially by the county superintendent to suit schedule of those taking the Teachers' course.

Subjects which may be given in alternate years are as follows:

13 and 23. 31 and 41. 33 and 43

15 and 25. 32 and 42. 34 and 44.

This alternation reduces the number of daily recitations from 21 to 15. However it may be better to make two divisions in class 15 and class 25 keeping first year pupils to themselves. The labor of daily preparation

of materials which is necessarily great will still be saved by the alternation.

Where the school can afford but two teachers or where much is attempted in manual training and domestic science or where grammar grade subjects are carried into the high school this course may be shortened by cutting off the fourth year and omitting 32, 33 and 34. In this case 31 would be given without alternation and 45 given in a modified form in the third year for the benefit of industrial and short course students.

Where the school can afford sufficient force of teachers, alternations should be done away with and more foreign language added.

Discussion.

The column headed "**Science**" gives suggestions as to the most important topics to be developed in each science subject and in a general way suggests the order of development. However no scheme such as this can properly deprive the teacher entirely of his right to plan the work after his own (enlightened) ideas of development of his subject. The topics enumerated refer to laboratory work, lectures, and text book assignments, though the laboratory work was most in mind in the preparation. Text book work should be regularly assigned ordinarily in the order presented in the text. The text book thus can usually be made the tangible means of continuity, giving a feeling of definiteness to the student and affording a means of review of principles. The laboratory work of this column generally precedes the corresponding subject in the "**Agriculture**" column and where possible is presented just preceding the season when its agricultural phase is at high tide on the farm. This seasonal succession dictates the order of presentation.

The column headed "**Agriculture**" suggests the best means of illustrating by familiar materials scientific principles which without familiar illustration would be valueless for whatever purpose. For principles are not required until they are applied nor are facts learned until they are visualized. This is the significance to the student who takes science for its 'cultural' purposes only. Conversely the column headed "**Science**" gives to the pupil of the Industrial course a mastery of the principles underlying his future vocation without which he is a slave to rule of thumb methods and tradition. To get the benefit of each others view point and to correct the unsymmetrical development each would get if segregated from the other it is necessary to have both groups of students in the same class and the science teacher should of course be the teacher of agriculture. Where the school provides courses in domestic science the teacher of that subject could very properly take the chemistry and assist in biology and physiology. But for general pedagogical reasons any attempt at specialization in teaching should so apportion the work

between teachers as to give the first year high school pupils as few teachers as practicable.

The **laboratory work** should all be done in one large room and recitations in science and agriculture should be conducted in the same room in the presence of the demonstration or some relie of it to condemn him who does not keep his wits about him. This plan will save much in duplication of apparatus and much more educationally in correlating and unifying all science through the agricultural medium. And this method will emphasize the fact that sciences even for cultural purposes are learned to be applied and that nature cannot be cheated into bestowing the blessing on him who falls short in this requirement. Pupils should see the setting up of each experiment and have a clear idea beforehand of what it is intended to demonstrate. All work prepared and demonstrated at the expenditure of considerable time and labor should be seen by and explained to all science pupils regardless of their classification. There should also be a special agricultural room convenient to the laboratory, suited for class use in grafting, budding, milk testing, weighing, cereal judging, etc., and storage.

Since agriculture deals with gross and variable materials the laboratory work in agriculture may easily be made more technical and exact than the occasion warrants. The teacher should remember that demonstration and not investigation is the purpose. And in the laboratory work in science a similar mistake may be made by leaving the pupil "stumped completely" by a printed laboratory guide which he is unable to translate into action. The teacher would much better have a hand in every experiment or operation than to risk a loss of interest that far outweighs the opportunity to teach the "scientific method." The teacher will accomplish much more by leading in manipulations and permitting pupils to repeat for their own satisfaction at their leisure when their delays are at their own expense.

The **daily program** may be so arranged as to bring agricultural work last on the days' program, the usual closing hour coming at the middle of the double period where the closing hour is 3 o'clock or earlier. The double period may be thus economically used for excursions and for bringing up irregular work of pupils where needed.

Certain additional **economies** in this course of study should be mentioned. It will be noticed that excursions are arranged to come in fall and spring terms when the season is more open and life more active and that agricultural literature is assigned principally to the winter term when the season induces less agricultural activity and storms and diminished daylight conduce to reading and study. It will also be noticed that the use of microscopes is prescribed so as to distribute them throughout of the three terms. Other economies to be suggested are the regular testing of milk samples and in the spring viability and purity tests of seeds at the laboratory and the weighing at the school of articles and stock marketed from or brought to the school community.

The habit of weighing, measuring and testing articles of commerce is a good one to cultivate and the establishment of stock scales at the school house may be made a means not only of studying fattening processes but of providing practice in all kinds of stock judging and of making the course more practicable for girls. And it will be the means of bringing to light the hidden genius of the stock judge, the expert guesser of weight "meek, inglorious" though he may otherwise be.

The **high school should admit** to its regular courses only those pupils who are of suitable high school age, of good mind and intentions and who have sufficient facility in reading, writing, figuring and language to carry the work without impeding their classes or unduly burdening their teachers. The principal may satisfy himself regarding these prerequisites by examination of the pupil or of his credentials. Short course students and farmers should be admitted to all agricultural work without scholarship requirements and without the correlated science work. They may prove a valuable ballast to the class and aid in preparing materials. They should be induced to qualify and enter regular courses. The division of the school year into fall, winter and spring terms makes it easy for short course students to enter for brief periods.

The **passing grade in agriculture** should be granted on attendance and performance of manual assignments and on concise notes and drawings rather than on ability to write an examination. Carefully kept note books should be insisted upon even at the expense of progress, and the expression of praise should be that "he did good work" rather than "he made good grades."

Other Subjects.

The other subjects of the high school course call for brief discussion. The inauguration of agricultural work need have no direct influence in dictating the work in the English, foreign language, mathematical or sociological groups, and what is said concerning them will, it is hoped, be correct pedagogy aside from the agricultural halo that pervades these pages.

The purpose of the **English course** is the teaching of correct expression, the mastery of a few classics and the instilling of a desire for more. Technical grammar and rhetoric are to be considered of value only in giving teacher and pupil a vocabulary for labelling different elements of structure and different forms of expression, whereby they may discuss understandingly the literature, themes and vocal expression which constitute the real subject matter of the course. As technical exercises of cultural or disciplinary value in themselves they should never be permitted to interfere with the primary purposes of the course. For such disciplinary purposes they should if used at all be placed last in the course where they will not interfere with the primary purpose; for cor-

rect expression comes most easily and most usually through practice with good written and oral models for imitation while technical grammar and rhetoric teach one to classify rather than correct his errors. Short themes and rhetorical should be frequent and the study of classics continuous. College entrance requirements in English have been a safe foundation for the course in literature. Mythology, biography, and political and literary history aid in their interpretation and contribute greatly to interest. The reading of modern fiction should come under the direction of the teacher, while no greater or more lasting pleasure can come from the course than a sympathetic study of standard fiction. The school library should provide standard fiction and juveniles from which to regularly prescribe and loan.

Authors of high school **mathematics** have too often preferred after teaching a principle to carry it into some difficult application rather than some useful application. A difficult task should have some justification other than the pleasure of its accomplishment. Teachers who have gotten past the difficulties easily forget that there may be little pleasure in approaching the task for the first time as the pupil does. It is a well known fact that class ranks are sadly decimated during the early part of the high school course and the cause may be partly here. To demonstrate mathematical principles by the easiest methods and drill in them by a sufficient variety of easy representative problems such as appears to be the plan of a new algebra by Slaughter and Lennes seems the best economy of time and effort. Physics as a fourth year subject should be quantitative with drill in measurement and a few illustrative problems for each principle involved.

Three classes by alternation covering four years' work in **foreign language**, preferably Latin, is as much as the three-teacher high school can afford. Should another teacher be added two years of modern language should be included.

The **sociological group** is intended especially for those who make the high school their finishing school, the assumption being that others will get such courses later in their studies. The ancient history will supplement the work of English and Latin classes, and the mechanical drill in book keeping and U. S. Constitution are well suited to the first part of the course. The work on the Constitution should be in connection with a review of the constitutional period of U. S. history. Citizenship and economics of the latter part of the course afford training in logic and debate and are correlated with the course in European history which affords examples of the origin and development of our present standards of economics and citizenship. The course in European History should devote special attention to the history of England.

Although **arithmetic** does not appear by name anywhere on this course of study no course devoid of agriculture could by giving arithmetic a distinct place in the course provide more valuable practice in all

applications of that subject than may be one of this kind. In the first year moisture and humus determinations and soil analysis give all applications of percentage and the half year in accounts provides business arithmetic; and those who desire may find the laws of liquids, gases, and machines rich in problems involving proportion and analysis. Plane geometry in the second year supplies mensuration in quantities sufficient for all demands while agricultural statistics form a distinct and much neglected phase of arithmetic including the making and reading of curves, and seed testing continues the use of percentage. The third year introduces a variety of the finest exercises in fertilizers involving proportion, analysis, and percentage while in the fourth year the making of rations, milk testing, and well planned farm problems in equipment, maintenance and variety of farming involve every chapter of arithmetic from weights and measures to alligation, with a chance to get more by the election of physics. Arithmetic presented in this form is vital and contributes to the agricultural work in such a way as to pay for the time and space it takes by requiring a precise knowledge of the agricultural or scientific factor involved which cannot be better emphasized and illustrated than by a problem. Moreover, considered purely as an arithmetical exercise no better medium for teaching arithmetic can be found than this where ability to understand concrete problems depends not upon the interpretation of a ready made statement of possibly unfamiliar factors which constitutes the chief difficulty of most students in arithmetic, while abstract principles of factoring, proportion, powers and roots are much more clearly introduced as presented in algebra and geometry free from the limitations peculiar to arithmetic.

Drawing, like arithmetic, should be taught regularly in connection with the Science and Agriculture and especially with the laboratory work. If the psychological moment for presenting a thing is when the student recognizes that the thing is needed, the need of drawing to express and record facts that cannot otherwise be accurately expressed justifies placing it with these subjects where the reciprocal advantage of interest and utility are secured. A plan suited to the development of the Science and Agriculture might be as follows:

I. Diagrams illustrating experiments and demonstrations. Drawing of vessels and apparatus. Perspective and shading.

II. Flowers, leaves, seeds and seedlings. Water colors. Sections of seeds and stems.

III. Insects and microscopic forms. Diagrams of invertebrate structure. Chemical apparatus.

IV. Vertebrate tissues and organs. Domestic animals. Farm buildings and devices. Lettering and map making.

III. Management of Agricultural Literature.

Nature of the Problem.

Whoever has been on the mailing list of the Agricultural Department and of the various experiment stations will know the confusion into which his tables and shelves soon come in his desire to preserve the hastily scanned tide of bulletins which come pouring in from fifty or more points of the compass.

A carefully prepared bulletin containing, as they often do, a high degree of scientific skill as well as months of patient labor in its preparation is, aside from its intrinsic merit, an object deserving of the greatest respect. But the necessity which condemns a large share of them "to be burned by the common hangman" is responsible for a bad habit which one may acquire of hardening his heart against the undiscovered merits of what may be a real treasure which unlicensed printing and the franking privilege throw at his head.

The value of agricultural bulletins has heretofore been chiefly as a means of communication between distant investigators and as a storehouse of the science. Little of the practical science is as yet in the text book form and what there is was taken mainly from bulletins. He who would have the best and cheapest information and he who would be at the forefront of agricultural progress will find it expedient to judge carefully before rejecting anything. The problem is easy for the specialist and there is no problem at all for such institutions as have ample library space for all agricultural bulletins nor for the large class who receive but have no use for any of them. But those to whom this article is specially addressed—schools with libraries whose scope is general but whose space is limited—may find it necessary to delve deeper than the title page before passing upon the value of an agricultural bulletin with anything like justice.

The point of view having been betrayed it may as well be said incidentally that every county should maintain a high school where (in addition to regular agricultural instruction) the following or some similar system of receiving, preserving and using the Farmers' Bulletins of the Department of Agriculture at Washington and the bulletins and circulars of its own state experiment station as well as the most appropriate, of neighboring states is practiced. Such literature and often well bound volumes of annual reports may be had for the mere asking. The one whose business it may be to receive and preserve in accessible form this heterogeneous mass to be used for convenient reference will need the

experience of some one who has had to consider this problem and assuming that the reader has had little if any, the writer will proceed to set forth a plan borrowed from various sources modified to suit the needs of the case and tested by some experience.

In seeking for a basis of classification—a general law running throughout the subject—one may easily overlook the very patent fact that bulletins are fortunately all of about the same dimensions. And this physical unity is the best one to consider in arranging them on the shelf. For this purpose boxes should be provided as shown in the accompanying figures.

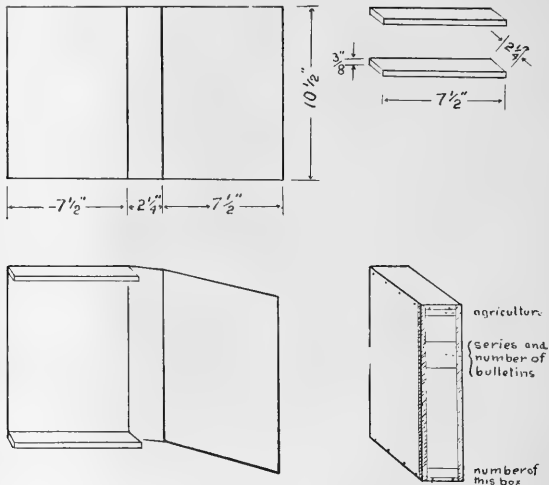

Fig 1

The Box.

The material used in making a box consists of what book binders know as No. 20 binding board which comes in sheets 26x38 inches one of which will cut four sheets of the desired size 17 1/4x10 1/2 inches. As the material is very dense and tough it should be cut in the bindery where purchased. Such material should cost not to exceed 5c. per box. The top and bottom of each box consist of poplar or soft pine strips each 10 1/2x2 1/4x3/8 inches planed and sandpapered. To bend the board around these strips it should be cut half through its thickness on the parallel lines 2 1/4 inches apart shown running across the center of each board. The board is bent with the cut side out and secured to the strips with small 3/8 inch wire nails with flat heads. The gaping wounds at the corner of the box are healed by strips of dark passe-partout. Labels

for the general and serial titles may be typewritten on light weight cardboard using different shades for different series of the latter. The bottom label—the box number—is cut from a calendar page.

Such a box when completed will hold thirty-three Farmers' Bulletins three boxes holding a hundred and this size will be found a good compromise of economy, convenience, and taste. The bulletins, arranged in serial order are wrapped over sides and loose edges with a piece of manila before shoving into the box.

Mr. F. H. Broome, Secy. of the Tennessee Experiment Station, recommends for general library use a box similar, but open only at the top and with one of the upper corners cut off to expose enough of the contents to grasp for lifting out. This type does not simulate a bound volume nor protect from dust so well for use in open shelves as the one recommended but is more convenient.

Indexing.

Without some convenient and accurate means of going direct to the desired information a collection of four or five hundred agricultural bulletins would be of little value for school or practical use. The valuable fact or process may be almost as inaccessible when needed as the proverbial "needle in a haystack." This makes necessary some system of indexing and at this point a diversion will be made to discuss the subject before making recommendations.

Among the plans that have been proposed for the classification of agricultural clippings and bulletins it is quite common to see recommended a system of boxes similar to the foregoing but with subject labels such as Horses, Spraying, Foods, Dairying, Fertilizers, Veterinary, etc., pasted on the exposed back, the purpose being to put into the appropriate box all literature coming under such heads. An illustration of such system is one described in the Breeders' Gazette of Nov. 13, 1907. The limitations of this method will be apparent to one who is familiar with that kind of bulletins of which a certain one on tomatoes is typical and which is found to treat more or less of the following other subjects: soils, fertilizers, plant diseases, food, tillage, and insects. When one considers such extreme examples as "A Successful Hog and Seed Corn Farm," it is apparent that to file such bulletin in the "Hog" box is to lose it from the "Corn" and the half dozen other boxes which may have nearly as good claims to it. And when one considers those special Farmers' Bulletins which periodically appear in the series containing synopses of experiment station work gleaned from a dozen states on as many or more distinct topics the insufficiency is all the more striking. To be consistent one must have duplicates in a number of different boxes. Therefore while the simplicity of the system may recommend it

for farmers' use high schools and college students should adopt a more perfect one for their more exacting demands.

Since therefore bulletins cannot be grouped topically the only systematic plan is to group them serially with a separate index of some kind under the appropriate division of which any bulletin may be recorded by its title and serial number as many times as it includes distinct topics. This brings up for consideration the system of classifying the general subject Agriculture into its constituent departments or sub-heads.

The Dewey decimal system of library classification contains under the general heading 600 (useful Arts) the sub-heads 630 Agriculture which has been still further expanded agreeable to the Dewey plan. But while this system includes a separate index it has inherent peculiarities which unfit it for our use. Among these is its plan of shelving literature in an order agreeable to subject matter which is open to the same objection as the box labeling system. While it is never used for indexing bulletins even in general libraries where the Dewey system prevails yet the contents of many bound volumes of annual reports or association meetings including a great variety of the best scientific papers are hopelessly lost while the book has one fixed position on the shelf corresponding to the single label on its back. Much might also be said about the inconsistency of a system which must provide for such subjects as Cement, Mortar and Concrete; Industrial Alcohol; Tuberculosis; The Gypsy Moth; the Lawn; etc.—all recent bulletins—under the agricultural head when there are distinct subject heads for each provided in other unrelated departments of that system. In fact the difficulty is too deep seated to permit a scientific classification on purely theoretical grounds of a living subject in process of evolution and the very apparent tendency of the literature is to unfit it more and more for such classification, as agriculture is not simply a science or a useful art but a mode of life that does not lend itself to such arbitrary dissection.

A system of classification of agricultural literature has been developed in the Office of Experiment Stations under conditions favorable to the present and prospective needs of agriculture. This office has been compelled for the past twenty years to consider for its own uses just the problem here discussed, and the result is a decimal system of classification under thirteen heads instead of the nine which the Dewey system requires. The system is used in all public libraries where bulletins are preserved. A key to the system is issued as circular No. 23 Office of Experiment Stations. The accompanying key is condensed to about one-sixth the original length in which form the writer uses and recommends it for high schools. The changes from the original consist of substitution of "Agricultural Education" for "12, Statistics of the Stations" and the development of "13, Miscellaneous" into "Agricultural Economics," the omission of all fractional subdivisions under all integral headings excepting Nos. 5, 6, and 7 and a general abbreviation

Condensed Key to Index of Agricultural Bulletins and Circulars.

	Page
1. General Sciences	1
2. Air and Water ; purity	1
3. Soils : composition, classification, tillage, improvement	4
4. Fertilizers ; sources, composition, use, experiments	7
5.01 Plants ; physiology, general, medicinal, improvement	2
.14 Field Crops : Commercial ; cereals, fibers, sugar, tobacco	8
.18 Secondary ; grass, hay, forage, silage, catch	6
.21 Horticulture ; vegetables, melons	7
.22 Fruit , nuts	7
.26 Flowers ; greenhouses, landscape	2
.3 Forestry	2
.4 Seeds	5
.5 Weeds	2
.6 Diseases ; remedies	5
6.1 Foods ; composition, nutritive value	8
.3 Preparation , use, accessories, beverages, adulteration	5
.7 Preservation	4
7.1 Animals ; physiology, general, wild, improvement	2
.3 Production ; stock, fowls, fish, invertebrates, rations	11
.4 Diseases ; veterinary	4
8. Entomology ; beneficial, injurious, repression	7
9. Dairying ; milk and its products	4
10. Technology ; manufacturing (not farm processes)	2
11. Agricultural Engineering ; materials, fuel, power, irrigation, drainage, implements, devices, roads, bridges, fences, buildings	6
12. Agricultural Education ; courses, methods, equipment	3
13. Economics ; general statistics, rural, home, hygienic, social, comparative agriculture	4

of the latter. Necessarily in abbreviating many fractions were dropped, their subject heads being thrown back into the next preceding number. Thus 5.22, as shown here includes all included under 5.22, 5.23, 5.24, and 5.25, of the complete system. In deciding on the elimination of certain numbers and the incorporation of their contents under other numbers the following rules were regarded: only adjacent groups were combined; only closely related subjects were combined; the amount of literature on a subject partly determined the practicability of combining it with another—the less the amount the better the reason for combining. In a few cases a careful consideration of all the literature showed the necessity of interpolating in a few cases as 5.01 and 5.18 which do not appear in the original system. With these alterations the original was preserved, so that familiarity with one is of value in using either.

In application of the system the bulletin or other unindexed pamphlet, is scanned and on the front cover are written Arabic numerals corresponding to such of the twenty-six topics of the key as are found treated inside. Thus Farmer's Bulletin 129 "Sweet Potatoes" should be labeled 5.21, 5.6, 6.1, 6.3 and 8, because in addition to its title it treats of plant diseases, nutritive value, preparation and use, and injurious insects.

4. Fertilizers; sources, composition, use, experiments		Bulletin No.
Leguminous plants for manure and feed	Farm.	16
Alfalfa or Lucern	"	31
Commercial fertilizers: composition and use	"	44
Manuring of cotton	"	48
Barnyard manure	" Ex.	56
Proportion of grain to straw	" Ex.	"
Phosphates as fertilizers	"	"
Harmful effects of muriate of potash	" Ex.	"
A germ fertilizer	" Ex.	65
Lime as a fertilizer	" Ex.	"

Fig 2

The index shown in Fig. 2 is made of a well bound blank book $7\frac{1}{2} \times 9\frac{1}{2}$ inches, containing 120 pages with 25 lines to the page and with the twenty-six subject headings so entered as to divide the contents into as many parts, each proportional in space to the number of entries that are to be made under it. Then taking the bulletins in serial order enter each title and serial number under all the subject headings treated in it as indicated on the cover. A sample page of the index is shown which also shows the numerical marginal labels. With the accompanying key pasted inside the front cover, on opening the index both the key and the marginal labels will be exposed to view. It will be noted

that only integers are shown on the marginal thumb labels, such mixed numerals as 5.21 coming between the 5 and 6 labels. This gives 13 marginal numbers though there are 26 subdivisions of the index. Fig 2 shows how to cut the leaf margins and where to paste the numerals which are cut from a calendar leaf.

Owing to the overlapping of such subjects as "field crops" and "horticulture" it may be necessary to index the same matter under two subject headings. In case of doubt a safe rule for the inexperienced is to make the entry under the several probable headings.

A pigeon hole card index system has been used by the writer and while more elastic than the blank book method is, on the whole, decidedly less desirable provided the book index be sufficiently large and the space equitably apportioned under the several heads. Experience has shown that the book described is ample for the purpose if it be apportioned as indicated on the right hand margin of the key. This apportionment is based on the first 300 numbers of the Farmers' Bulletins. After one series of bulletins has been indexed down to some convenient recent date others in turn are entered until every pamphlet considered worth the space is recorded and boxed.

The Case.

Having been properly indexed and boxed a home for this literature is next to be provided. The accompanying illustration (Fig. 3) shows a case sufficient for the agricultural library and museum. It can be made of pine without doors for 9 or 10 dollars and of oak for about 11 dollars. Doors as shown with glass panels double the cost. The writer has had materials for such a case made at a planing mill without mortising and with tongue and groove (ceiling) back and shipped to destination where it is easily set up and stained with a dull walnut stain by pupils of a little manual skill.

This case provides ample room for the boxes on one shelf leaving the bottom shelf for an agricultural museum of minerals, soils, fertilizers, feeds, seeds, herbarium, and insects. The top shelf is for the accompanying list of recommended agricultural reference books and the second shelf for yearbooks and reports. The index to the bulletins should be kept in the shelf with them and contain a record of all the literature on that shelf. Bound volumes having indexes should not be indexed in this system.

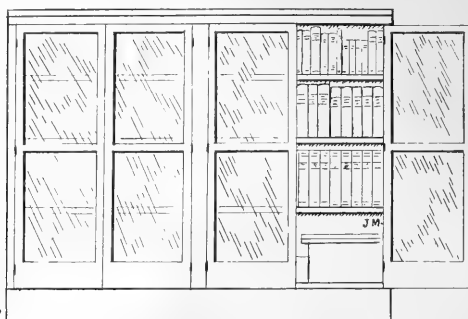

Case complete with doors

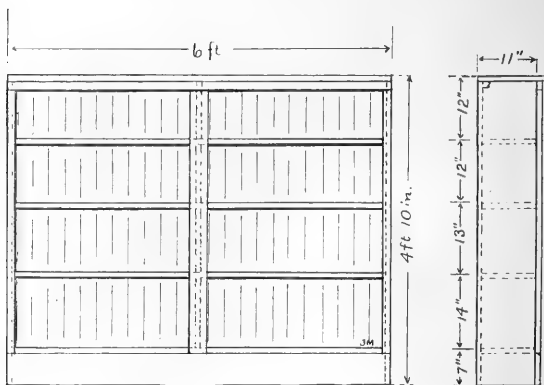

Fig 3

Assignments on agricultural topics may be made by the teacher and the index should enable the pupils to find the latest and most practical information on the subject. Whatever such a collection properly indexed may lack of being a complete encyclopedia of agricultural science and practice is a defect that time will speedily make good. A blank card should be inserted in each box on which to record names and dates of loan and return.

Text and reference books in agriculture and related sciences suitable for high school library.

Elementary Agriculture.

Soule, A. M. and Turpin, E. L.—“Agriculture, its Fundamental Principles.” (B. F. Johnson Pub. Co., Richmond; 320 pages, \$.75.)

Davis, C. W.—“Rural School Agriculture.” (Orange Judd Co., N. Y., 267 pages, \$1.00.)

High School Agriculture.

Stevenson, W. H. and Schaub, I. O.—“Soil Physics Laboratory Guide.” (Orange Judd Co., N. Y., 100 pages, \$.50.)

Vivian, A.—“First Principles of Soil Fertility.” (Orange Judd Co., N. Y., 265 pages, \$1.00.)

Smith, H. R.—“Profitable Feeding.” (University Pub. Co., Lincoln, 413 pages, \$1.50.)

Craig, J. A.—“Judging Live Stock.” (Published by the author, Des Moines, 187 pages, \$1.50.)

Van Norman, H. E.—“First Lessons in Dairying.” (Orange Judd Co., N. Y., 95 pages, \$.50.)

Conn, W. H.—“Bacteria, Yeasts, and Molds in the Home.” (Ginn and Co., Boston, 293 pages, \$1.00.)

Spillman, W. T.—“Farm Grasses of the United States.” (Orange Judd Co., N. Y., 250 pages, \$1.00.)

Hunt, T. F.—“Cereals in America.” (Orange Judd Co., N. Y., 421 pages, \$1.75.)

Hunt, T. F.—“Forage and Fibre Crops in America.” (Orange Judd Co., N. Y., 428 pages, \$1.75.)

Advanced Agriculture.

King, F. H.—“Physics of Agriculture.” (Published by the author, Madison, 604 pages, \$1.75.)

King, F. H.—“The Soil.” (Macmillan and Co., N. Y., 303 pages, \$.75.)

Bailey, L. H.—“Horticulturist's Rule Book.” (Macmillan and Co., 312 pages, \$.75.)

Bailey, L. H.—“Nursery Book.” (Macmillan and Co., N. Y., 365 pages, \$1.00.)

Bailey, L. H.—“Pruning Book.” (Macmillan and Co., N. Y., 545 pages, \$1.50.)

Sanderson, E. D.—“Insects Injurious to Staple Crops.” (J. Wiley & Sons, N. Y., 295 pages, \$1.50.)

Plumb, C. S.—“Types and Breeds of Farm Animals.” (Ginn and Co., Boston, 563 pages, \$2.00.)

Davenport, E.—“Principles of Breeding.” (Ginn and Co., Boston, 727 pages, \$2.50.)

General Science.

Tarr, R. S.—“New Physical Geography.” (Macmillan and Co., N. Y., 457 pages, \$1.00.)

Davis, W. M.—“Elementary Physical Geography.” (Ginn and Co., Boston, 401 pages, \$1.25.)

Leavitt, R. G.—“Outlines of Botany,” with Gray’s Flora. (American Book Co., Cincinnati, 791 pages, \$1.80.)

Osterhout, W. T. V.—“Experiments with Plants.” (Macmillan and Co., N. Y., 492 pages, \$1.25.)

Bergen, T. Y.—“Foundations of Botany.” (Ginn and Co., Boston, 412 pages, \$1.20.)

Gray, Asa—“Manual of Botany.” New Edition. (American Book Co., Cincinnati, 926 pages, \$2.25.)

Herrick, G. W.—“Text Book of General Zoology.” (American Book Co., Cincinnati, 386 pages, \$1.20.)

Herrick, G. W.—“Laboratory Exercises in General Zoology.” (American Book Co., Cincinnati, 110 pages, \$.60.)

Eddy, W. H.—“General Physiology and Anatomy.” (American Book Co., Cincinnati, 521 pages, \$1.20.)

Eddy, W. H.—“Experimental Physiology and Anatomy.” (American Book Co., 112 pages, \$.60.)

Snyder, H.—“Chemistry of Plant and Animal Life.” (Macmillan and Co., N. Y., 406 pages, \$1.25.)

Rensen, Ira—“College Chemistry.” (Henry Holt and Co., N. Y., 689 pages, \$2.00.)

Industrial Pedagogics.

Kern, O. T.—“Among Country Schools.” (Ginn and Co., 366 pages, \$1.25.)

“U. T. Farmer.”—University of Tennessee, Knoxville. Monthly, 50 cents a year.

Farmers Bulletins.

In addition to the complete set duplicate copies of the following Farmers’ Bulletins for class use should be provided space in the library: Nos. 22, 34, 42, 47, 51, 55, 63, 66, 71, 86, 95, 106, 112, 121, 126, 127, 132, 134, 147, 154, 155, 157, 161, 179, 181, 183, 185, 187, 192, 195, 203, 218, 235, 245, 247, 253, 255, 256, 260, 266, 270, 278, 287.

IV. The Laboratory.

So much has been said in previous discussion on the laboratory work in science and agriculture as to leave this portion mainly an enumeration of details, apparatus and supplies. For what is considered good pedagogical reasons the use of one large room for both laboratory and recitation purposes is recommended for the average school. Besides the influence which the presence of the demonstration before the pupil may have in preventing class exercises and reviews from becoming mere recitations of the words of the text book there is the added advantage of destroying the artificial barriers so often built between the natural sciences. The use of agricultural materials especially will aid in unifying science. For recitation use the recitation end of the science room should have seats with writing arms, a blackboard, and instructor's desk, maps, charts, and the agricultural library case. The other end of the room should have a sink with two taps, a cupboard similar to the accompanying cut Fig. 4 which is made of pine and stained dark at a cost of \$26.00, gas connections if possible, three kitchen tables, vertical and cross beams between floor and ceiling and wall shelves as shown in Fig. 5. These shelves consist of (a.) an open cupboard for chemical reagents, (b.) a shelf above the sink, (c.) a draining board at end of sink, (d.) a wall shelf for fine scales with drawer for weights, and (e.) a hood for ignition. These shelves may be made of oak at the following cost: (a.) \$3.00; (b.) \$2.50; (c.) \$1.50; (d.) \$2.00 (e.) \$7.00. Where gas may be afforded

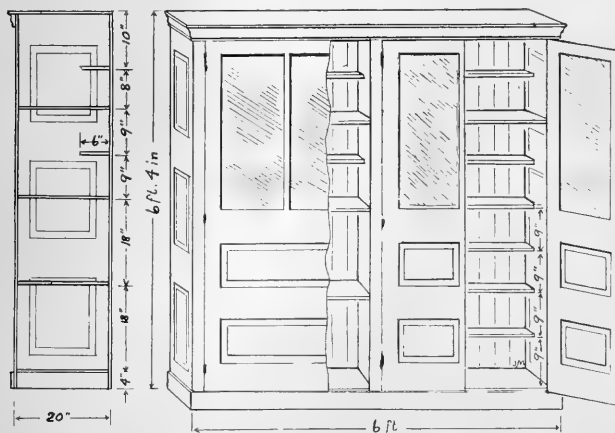

Fig. 4.

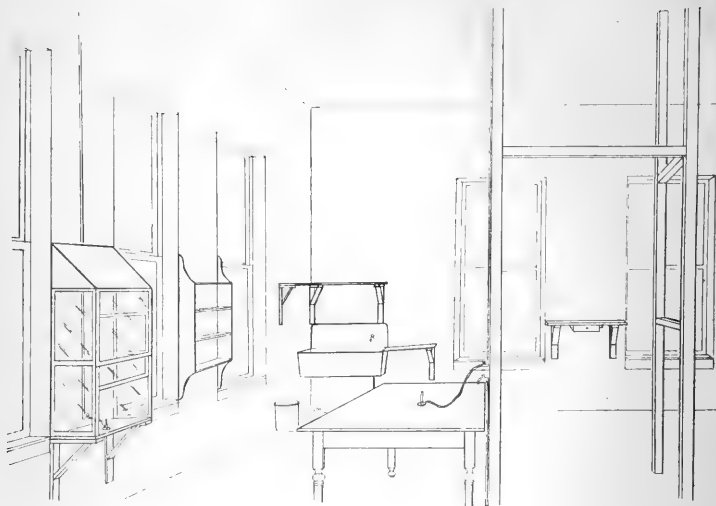

Fig. 5.

it should be provided, otherwise alcohol and gasoline should be used: The list of chemical apparatus which follows provides both kinds but contemplates the omission of such as is not needed, depending on whether or not gas is available.

In selection of the preceding and following articles of equipment regard was constantly had for a maximum beyond which the average high school may not be able to go. And to save expense of unnecessary duplication of apparatus prices are omitted from such articles as may be provided elsewhere in the list. Thus beginning with "chemicals," "chemical apparatus" and "glassware" in order the list is made complete but such articles as occur therein that are needed in other sciences are enumerated in the group where needed but with reference to the previous group where provided and with the intention of providing them in but one list. The prices set opposite the various articles are taken from bills supplied by two different firms and from a school supply catalogue and a general merchandise catalogue.

CHEMICALS

Quantity	Article	Price
1 lbs.	sulphuric acid c. p.	.75
6 "	hydrochloric acid c. p.	.85
7 "	nitric acid c. p.	1.10
2 "	acetic acid glacial	1.02

1	"	oxalic acid	commercial	.12
4	"	ammonium	hydrate	.76
1	"	"	chloride	.34
2	"	"	nitrate	.90
1	"	"	alum	.08
1	"	potassium	alum	.08
2	"	"	hydrate	.60
1	"	"	carbonate (pearl ash)	.15
2	"	"	sulphate crystals	.30
2	oz.	"	iodide cryst., pure	.60
1	lb.	"	nitrate c. p.	.37
1	"	"	chloride c. p.	.37
1	"	"	permanganate c. p.	.70
2	"	"	chlorate, cryst.	.30
$\frac{3}{4}$	oz.	potassium		.45
8	"	sodium		.70
2	lbs.	"	carbonate cryst.	.25
3	"	"	hydroxide sticks	.75
2	"	"	nitrate c. p.	.60
2	"	"	chloride	.10
1	"	"	sulphate	.10
1	"	"	sulphite crystal	.10
3	"	calcium	chloride, anhydrous, fused	.60
1	"	"	fluoride	.10
1	"	"	sulphate, gypsum	.10
5	"	"	sulphate, plaster paris	.15
3	"	"	oxide, quicklime	.30
5	"	"	carbonate, marble chips	.25
1	"	magnesium	sulphate c. p.	.34
1	oz.	"	ribbon	.60
1	lb.	ferrous	sulphide	.10
4	oz.	ferric	chloride	.15
5	lbs.	"	sulphide	.35
2	"	iron	filings	.10
1	"	copper	foil	.90
8	oz.	"	nitrate	.25
8	"	"	oxide	.35
5	lbs.	"	sulphate	.50
2	"	barium	chloride crystals	.25
$\frac{1}{2}$	"	"	peroxide	.35
1	"	lead	nitrate	.18
1	"	"	peroxide	.36
1	"	red	lead	.12
6	"	mercury		.80
3	oz.	red oxide of	mercury	.30
4	"	mercuric	oxide	.40
$\frac{1}{2}$	"	silver	foil	.60
1	"	"	nitrate	.50
1	lb.	carbon	bisulphide	.20
5	"	manganese	dioxide 95 per cent.	.25
1	"	granulated	tin	.60
$\frac{1}{2}$	"	antimony	powdered	.25
1	oz.	strontium	chloride	.10
1	"	bismuth		.30
2	"	iodine	crystals pure	.75
1	"	red	phosphorus	.15
8	"	yellow	phosphorus	.50
1	lb.	borax		.18
2	"	zinc	granules	.32
1	"	flowers of	sulphur	.08
5	"	roll	sulphur	.25
1	"	bleaching	powder	.10
1	oz.	litmus		.10
1	"	phenolphthalein		.10
2	"	cochineal		.16

½ gal	alcohol wood	.50
½ "	" ethyl, 95 per cent.	1.50
2 "	" denatured	1.50
2 "	" gasoline	.40
1 lb.	corn starch	.10
2 "	cane sugar	.20
2 "	bone black	.15
1 "	rosin	.10
1 "	paraffin	.15
1 "	tallow	.15
1 "	beeswax	.65

CHEMICAL APPARATUS

2	Bunsen burners	.66
	gasoline burner, see "agriculture"	
4	spirit lamps, 4 oz., side tubulation	1.20
	asbestos mat, 24 x 18 x 3-16	.66
	wing tip for Bunsen burner	.18
	desiccator, 6 inch with porcelain bottom	1.00
1 nest	Hessian crucibles, large 5's	.18
1 doz	Royal Berlin crucibles with covers, 41 m m	2.00
8	pipe stem triangles, No. 4	.50
1 pair	brass crucible tongs, 9 inch	.48
2	tripods for spirit lamp	.50
2	pieces wire gauze, 5 x 5 inches	.30
	copper retort, 2 pints	2.85
2 pair	test tube holders, brass	.22
	platinum wire, 4 inch, No. 26	.30
	blowpipe	.20
	deflagration spoon, 12 m m	.11
	sand bath, 6 inch	.22
2	iron ring stands, 3 rings each	1.10
8	porcelain evaporating dishes, No. 7, 3½ inch	1.20
1 pair	steel forceps 6 inch	.15
	balance, "Kistler" 1 cg. to 100 g	12.00
1 set	brass weights in block, 1 cg to 100 g	1.35
1 pair	brass forceps	.16
2	test tube racks for 24 test tubes	.80
3	test tube brushes, with sponge	.25
3	test tube brushes, small	.12
	lead dish, 3 inch	.22
	mortar and pestle, Wedgewood 3 in.	.44
2	wash bottles, complete, stopper and tubes, 24 oz.	1.00
3	gas generating bottles, complete	1.50
2	calcium chloride tubes, 150 m m	.24
2	funnel stands, 4 holes each	1.30
	pneumatic trough	1.10
6	chemical thermometers, 10° to 110° c.	4.20
2	chemical thermometers, 20 to 200	2.00
2	earthenware slop jars, 3 gal.	.60
½ lb	asbestos wool	.20
1 oz	glass wool, fine	1.36
	drying oven, (at tinnets)	3.50
	horn scoop, 3 x 3½	.22
	horn spoon, 6 inch	.18
	piece magnetized clock spring, 6 inch	.10
2	Mohr's clamps, small	.22
2	Mohr's clamps, medium	.30
2	Hoffman's pinch cocks	.44
	triangular file, rattail file	.25
4 sheets	litmus paper, red and blue	.32
8 pkgs	filter paper, 600 4 inch, 200 6 inch	1.00
17 doz	corks regular length as follows	
	one doz, each Nos. 3 to 16 and 18 and 20	2.54
1 set	cork borers 1-6	.80
	rubber tubing and rubber stoppers see "el. phys."	
	dropper bottles see "biology"	

GLASSWARE

2 doz.	test tubes of each following sizes: 5x5-8, 50, 6x3-4, 56, 7x7-8, 80	1.86
6 nests	beakers 1 to 4	2.10
3	flasks each 8 oz. and 16 oz.	1.02
4	erlenmeyer flasks 6 oz.	.72
4	thistle tube funnels	.27
½ doz.	funnels 60° 2½ inches	.54
2	funnels each 3 inch, 4 inch, 6 inch	1.52
6 lbs.	glass tubing, 3 ft. long assorted following sizes: 3-16, 1-4, 5-16	2.40
4	watchglasses, 3½ in.	.37
2	retorts, 8 oz. with receivers	.74
1 doz.	square blue glass, 3 x 3	.91
1	" stirring rods	.16
2	burettes 50 c. c.	2.20
	pipette 25 c. c. volumetric	.25
	pipette, Mohr's 10 c. c. graduated	.40
½ doz.	cylindrical graduates 100 c. c.	2.40
4	" cylindrical graduates, 25 c. c.	1.20
1 doz.	each bottles wide mouth, "prescription" 32 oz., 8 oz., 4 oz	2.35
1	each bottles "tincture" mushroom stopper 32 oz., 16 oz., 8 oz	4.35
1	" bottles "salt mouth" mushroom stopper, 32 oz.	2.40

ELEMENTARY PHYSICS

	spirit level	1.25
	model lifting pump	1.65
	model force pump	2.00
1-3 "	meter sticks, brass tipped	1.40
3	lever holders	1.20
1 set	universal weights	2.00
¼ doz.	brass pulleys with hooks	1.00
1-3 "	spring scales, 1-2 to 5 lbs	1.40
	balance and weights, see "chem app."	
1 set	capillary tubes	.95
	hydrometer, paraffined stick	.25
	hydrometer see Quevenne lac. "agriculture"	
	hydrometer jar 15 x 2½	.40
	thermometer see "chem app."	
	3-scale thermometer, F. R. C	.80
	hypsoneter	3.00
	protractor, metal	.60
	barometer tube with bend and bulb	.55
	Boyle's law stand	2.00
	Hale's pressure gauge	.95
	glass tubes see "glassware"	
18 ft.	rubber tubing, white as follows: 12 ft. 1-4 inch, 6 ft. 3-16 inch	2.10
6 ft.	rubber tubing, red antimony 3-16 inch	.54
9	rubber stoppers as follows: 4 each 2 hole Nos. 7, 8, & 11 4 each solid No. 6 1 each 2 hole No. 12	2.01 .35 .30
4 doz.	cork stoppers, flat as follows: 1 doz. each, diameter 1 3-4, 2, 2 1-4, 2 1-2, inches	145
	cork borers and cork stoppers, regular length see "chem. app."	
5 lbs.	sheet lead 1-16 inch	64
	mercury, see "chemicals"	
5 lbs.	shot No. 5	.40
1 box	assorted rubber bands	.80
½ lb.	copper wire No. 18	.33
1	" iron wire soft No. 28	.18
1	spool each silk thread, linen thread	.15

BIOLOGY

2	microscopes	70.00
2	bell glasses, 14 inch, 2 gal.	3.30
1 doz.	tripod magnifiers	4.80
	dissecting microscope . . .	1.00
1 gross	slides, 1 oz., cover glasses	1.90
	razor	1.00
300	insect pins, 3 sizes39
½ doz.	dissecting sets (scalpel, scissors, forceps, 2 needles)	5.00
½ lb.	each formaldehyde, 40, ether, 75, potassium "cyanide," 45, wide mouth 8 oz. bottles, see "glassware"	1.60
	carbon bisulphide and potassium permanganate, see "chemicals"	
1 doz.	granite pans, 9 x 12 shallow	4.00
1	" medicine droppers	.45
½ "	dropper bottles, glass bulb	1.20
10	petri dishes	3.00
1 lb.	agar agar	1.00
1	" chloroform	.75
6 oz.	benzole	.50
6	" glycerine	.20
8	" rochelle salts	.10
2	battery jars, 9 x 12, 2 gal.	2.00
½ doz.	battery jars, 6 x 8, 1 gal.	2.00
½ "	specie jars, gal.	2.52
1	" window glass, 10 x 10	1.00
½ "	lantern globes	1.00
¼ lb.	assorted rubber bands	.80
2 boxes	gummed labels, 2 sizes	.25
	silk thread, linen thread, flat corks, rubber tubing, rub- ber stoppers, see "cl. phys."	
	thistle tubes, cork corers, see "chem. app."	
	mosquito bar, white, see "agriculture"	

AGRICULTURE

	bucket spray, "Success"	7.00
	extension rod, 8 ft.	2.50
	extension hose, 15 ft.	1.50
	nozzles, conical "Vermorel" .50 and "Mistry" 1.00	1.50
	nozzle, flat "Bordeaux"	.35
	pruning saw, adjustable	1.25
	pole attachment for adjustable saw	.75
	pruning shears, (grape) .50, pruning knife, .50	1.00
	pruning shears "Buckeye"	.50
	grafting chisel	.50
2 doz.	budding knives	3.60
	paris green, copper sulphate, sulfur, lime	2.00
	resin, beeswax, tallow, see "chemicals"	
	centrifuge milk tester, 8 bottles	8.00
1 doz.	milk bottles for tester	1.50
½ "	cream bottles	1.00
½ "	skimmed milk bottles	3.00
	acid measure	.15
	pipette 17.6 c. c.	.20
	Quevenne lactometer	.50
	hydrometer jar, see "element. phys."	
27 lbs.	sulphuric acid, s p. gr. 1.83	2.40
1	" corrosive sublimate tablets	1.25
	soil auger	2.00
	iron mortar, ½ gal. and pestle	1.00
1 doz.	sealing jars, "Lightning" quart	1.65
1	" sealing jars, "Lightning" pint	1.50

½ "	soil capillarity tubes, glass 5 ft. x 1 1-4 inch	3.00
	drying oven 100° C., crucibles, desiccator, slop jars, Bunsen vapor lamp, thermometers, brass tongs, balance, see "chem. app."	
2	percolators, qt.	1.00
	small tin grocers' scoop10
	cylindrical graduates see "glassware"	
	coarse balance (grocers') with weights ½ oz. to 4 lbs.	3.00
½ doz.	small granite pans, circular90
	iron pans and troughs (at tanners)	3.00
	sand, sawdust, muslin, cheesecloth, mosquito net, cotton thread	1.00
	specie jars, see "biology"	
	shot, spirit level, see "el. phys."	
1 set	sample soils 28	1.50
1 "	economic seeds	1.50
1 "	weed seeds	1.50
1 doz.	smooth dinner plates	1.20
1 gross	vials, 2 drachm .85, stoppers .15	1.00
1 set	brass gauze sieves, 5 sizes	5.50
1 doz.	tripod magnifiers, see "biology"	
2 "	flower pots, 3-4 gal. with saucers	1.70
	steel tape 50 ft.	2.50
	muriate of potash, acid phosphate, ground rock phos- phate, bone meal, lime, limestone	5.00
	magnesium sulfate, potassium sulfate, ammonium sulfate, ferric chloride, see "chemicals"	

TOOLS

	hollow handle tool	1.12
	vise, small75
	hatchet50
	back saw	1.30
	brace and bits	1.00
	square30
	pliers and wire cutters85
	pincers, small25
	whetstone45
1 lb.	each iron wire. No. 24 and No. 1835

V. School Plots.

Leaving out of consideration school gardens, which apply to elementary grades, and vegetable gardens, which though valuable are not necessary demonstrations to the high school course as herein conceived, and confining attention to those demonstrations peculiar to general agriculture and called for by the foregoing course of study we may group them into three series as follows: the first series to illustrate fertilizers and rotations, the second, forage and cover crops, and the third, desirable introductions.

Beginning with the last, desirable introductions will in most communities include rape, kale, sorghum, resistant clover and more especially alfalfa. These demonstration plots should be small, about 1-80 acre each except the alfalfa which should be larger. The approved method for getting a stand of alfalfa is as follows: "Plow deep in the fall applying fertilizer at the rate of 50 lbs. muriate of potash, 300 lbs. acid phosphate and 12 tons of barnyard manure per acre. Sow to rye and vetch, turn under in the spring, apply 2000 lbs. of lime per acre, plant soy beans, and cultivate all summer. Repeat the process for the second year. Harvest the second crop of beans and sow 30 alfalfa seed per acre by Sept 1." (Tennessee Experiment Station.)

The second series demonstrates the management of crops raised mainly for soiling and winter cover. In all these combinations there are two crops per year, the winter crop being usually a combined cereal and legume which is harvested green as needed for feed and the land at once put into a summer crop of peas and beans to be harvested in the fall in time for the following winter crop. Where a variety test is made of either the winter or summer crops the crop alternating during the remainder of the year should be the same for the varieties tested. Following are some of the varieties recommended with the rate per acre in lbs.:

Winter crops: cereals; rye (60), wheat (60), oats (48). Winter crops: legumes; vetch (30), crimson clover (20), alsike (15). Summer crops: mammoth yellow soy bean, Ito san cowpea, medium yellow cowpea, early medium yellow cowpea, Jap pea, and No. 1538, either at the rate of 20 lbs. per acre.

It is recommended to consider all the varieties of cowpeas as experimental followed by a standard winter cover crop of rye and vetch (1-4 acre) and to consider other combinations of cereal and winter legume as experimental, all followed by a standard summer crop of 1-4 acre of mammoth yellow soy beans, thus making a half acre for this series. The purpose of equalizing conditions by having the same summer crop on all comparative tests of winter varieties and of having the same winter crops on the portion devoted to summer variety tests will be apparent.

Series one of the school plots is a very important demonstration and requires exactness in its preparation and care. A test of different kinds and combinations of fertilizers demands the use of definite quantities, the continuity of the demonstration through a number of seasons—the result getting to be more apparent and valuable the longer it runs—and a uniformity in size of plots. And it is essential first of all that the area devoted to the test be uniform in character throughout that difference in results on different plots may be attributed wholly to the character of fertilizer. The plan shown in Fig. 6 and the accompanying explanatory notes show how this exactness is to be attained and one of the ranges shows the plan of applying fertilizers.

Considered as a rotation demonstration, series one is intended to show simultaneously the four annual phases of a four year rotation as they would appear June 1 of any year. The crops selected are such as prevail all over the state and are worthy of recommendation. Their order of succession on each range is as follows: 1st year, cowpeas, 2nd year, wheat, 3rd year, clover and grass, and 4th year, corn. The cowpeas are sown in the spring and disposed of in time to prepare range for wheat. With the wheat is sown red clover or alsike and in the spring any suitable grass seed may be added as desired. This clover and grass is then let run until the second spring after wheat is harvested. The

Series I ROTATION and FERTILIZERS

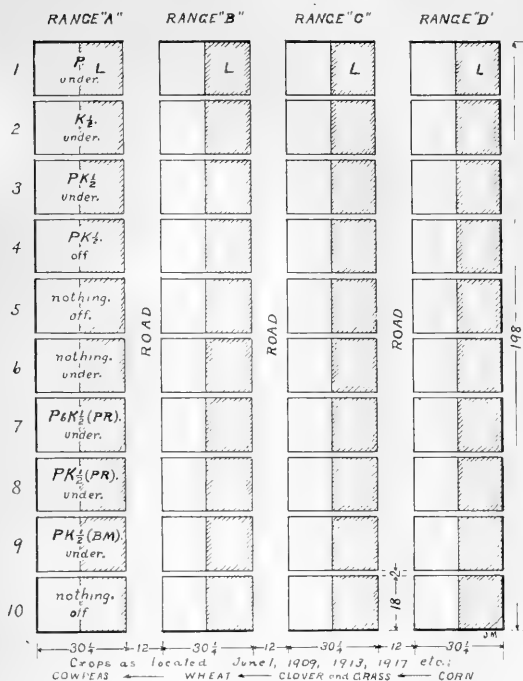

Fig. 6.

EXPLANATION: Size of plots 18 ft. x 30 1/4 ft. (one eightieth acre) with 2 ft. paths between

Size of Ranges 198 ft. x 30 1/4 ft. with 12 ft. road between
Fertilizers are applied once in rotation (4 yrs.)

P=300 lbs. high grade acid phosphate per acre having 16% P₂O₅.
P₂=twice above amount; P₆ six times, etc. P (PR)=150 lbs. per acre
ground rock phosphate. P (BM)=200 lbs. per acre steamed bone meal
24% P₂O₅ K=100 lbs. muriate of potash per acre 50% K₂O F=6 tons
farm yard manure per acre. L=2000 lbs. lime per acre

Half of right-half of each range has lime applied once in each
rotation

"Off" and "under" indicate whether cowpea crop is to be har-
vested or turned under as green manure

grass is turned under the spring of the corn year. After harvesting the corn the fertilizer is applied as shown on the cowpea range—the application being made but once for the entire rotation. Follow the corn by a winter cover crop of rye to be turned under in the spring when lime is applied to the right half of the range and cow peas again sown. This application of fertilizers and lime coming between the corn crop and the cowpea crop occurs on each range but once in each four years but as the series has four ranges each showing an annual phase of the rotation the fertilizers and lime are applied on one range each year. The illustration (Fig. 6) necessarily shows the crops as having fixed positions on the ranges but it should be understood that the regular succession of crops will make the condition represented applicable but once in each four years, viz.: 1908, 1913, 1917, etc.

The corn and wheat ranges may be utilized as breeding plots.

Since the fertilizer is to be applied but once in the four years of the rotation, in beginning the demonstration where one wishes to start with all four of the crops the first season fertilizers may be applied on all the ranges as follows: full amount preceding the cowpea year, 3-4 amount preceding wheat year, 1-2 amount preceding the clover and grass, and 1-4 amount preceding corn.

Any county high school or any public school in Tennessee accredited to this university which can undertake these demonstrations with some assurance of success will command the services of the university. Such services include laying out of the plots agreeable to a plan uniform for the entire State; advice by correspondence with this department and with the Experiment Station; occasional personal inspection; a system of recording results on blank forms furnished by this department; and the dissemination of results by printed reports and by conference of teachers. Since the Department of Agricultural Education desires to be a clearing-house for results, criticisms, and alterations for all schools looking to us for this aid and advice, any changes from the plan designed to lessen the work should first come to this department. The advantage of a uniform system for the entire state, whereby teachers may be able to communicate by letter or conference, to report results on a blank provided by us for permanent record and in making possible the distribution of a brief printed annual report of all the schools for the benefit of all, will appeal to all systematic workers.

Many other plots can be used to advantage where time will permit, to demonstrate approved varieties and methods especially in gardening but they will be left to the teacher's individual plans. The foregoing three series include all of the demonstrations essential to the course of study as presented.

VI. Conclusion.

The qualifications for the agriculturist should include (besides character) collegiate training in agriculture, since in no other place can the ability to appreciate exactly the significance of each agricultural topic enumerated, to give it its proportionate space in the general scheme, to develop its relation to the general sciences, and to utilize it for illustration of a scientific principle be acquired. The best evidence of such qualification is a college degree in agriculture from a good college.

Since the greatest danger to successful work in agriculture in our present methods of school administration is the uncertain tenure of teachers from which follows the habit of laying down duties at the close of the term in May to be resumed if at all not before September, the board cannot give this work any greater assurance of success than by engaging the agriculturist by the year and as a part of his consideration provide him a residence on the grounds where in addition to his plot work he should have at least ten acres in cultivation for the double purpose of demonstrating successful agriculture and horticulture and of making a profit for his school. Much more than this amount is not necessary if the farms of the locality are used by students as their laboratory in which to emulate their teacher and apply his teachings. The burden of responsibility thus comes where it should, on each individual, and the factor of pecuniary profit is properly used as a means of success. The instinct to look out for oneself financially has certain ethical limits within which it is not only allowable but commendable and should be encouraged. Experience has shown that the plan of working a large farm in connection with the school is in danger of the financial failure that has usually attended communistic enterprises and moreover would violate the ideal sought to be inculcated by this manual. But failure to provide work for the summer means a neglect of demonstration plots—a very bad lesson to the community—and a loss of the cumulative value which comes of carrying over into each successive year the accomplishments of previous years. The expense of equipment elsewhere estimated should be acceptable to the school board before the work is begun.

The author was disposed to verify the accuracy and wisdom of certain suggestions and details herein set forth of which he is uncertain, with the assistance of others working in the same or related fields but knowing that time and experience alone will perfect the scheme and that at best a revision will soon be necessary, submits it for both criticism and use. A model laboratory and library after the foregoing plan will form a part of the equipment of this office for inspection of visitors as well as for class use. This equipment is selected within a rigid expense limit such as is imposed on the average high school.



Summarized, the expense of equipping a school for teaching science and agriculture would be about as follows:

Library case, \$21.00; table \$5.00	\$26.00
Books	42.00
Laboratory cupboard, 26.00; shelves, 16.00; tables, 4.00	46.00
Laboratory supplies (as follows)	342.74
Chemicals	\$35.68
Chem. apparatus	52.72
Glassware	28.16
Element. Phys.	29.65
Biology	109.76
Agriculture	79.90
Tools	6.87
Horse, 125.00; wagon, 35.00 and tools, 75.00	235.00
Total,	\$691.74

It is estimated that other outside expenses of the plots may be paid for by profits from the crops. They will include hot bed and cold frames and extra team and labor. The consideration for the use of the agriculturists cottage should be computed in fixing his salary and should be sufficient to pay a profit as an investment by the school.

Prices and places for securing the seed, fertilizers, apparatus, furniture and implements called for in this manual may be obtained by consulting the advertising pages of the U. T. Farmer, a monthly journal devoted to agricultural education and progress published at the university of Tennessee, Knoxville, Tenn., at 50c. per year.

All inquiries should be addressed to

Josiah Main,

Department of Agricultural Education,

University of Tenn., Knoxville, Tenn.



LIBRARY OF CONGRESS



0 002 744 471 4

LIBRARY OF CONGRESS



00027444714

Hollinger Corp.
pH 8.5