

UNIVERSITY OF TORONTO



3 1761 00327454 5

A  
MANUAL OF FORESTRY  
BY  
W. SCHLICH.

VOL. II.  
FORMATION AND TENDING OF WOODS  
OR  
PRACTICAL SYLVICULTURE.



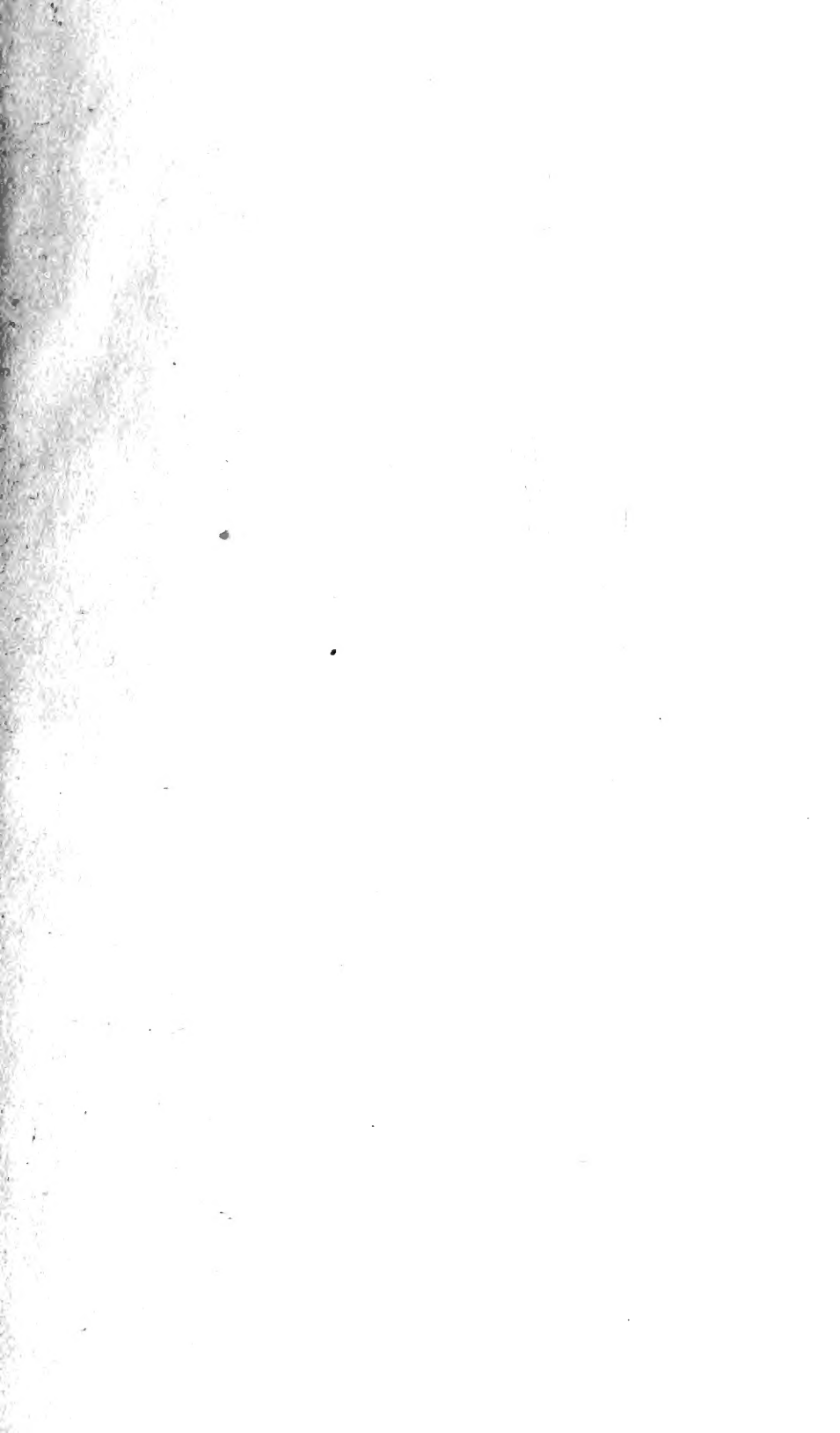

Digitized by the Internet Archive  
in 2007 with funding from  
Microsoft Corporation

*With the author's compliments*

*M. H. Brown*



**MANUAL OF FORESTRY.**

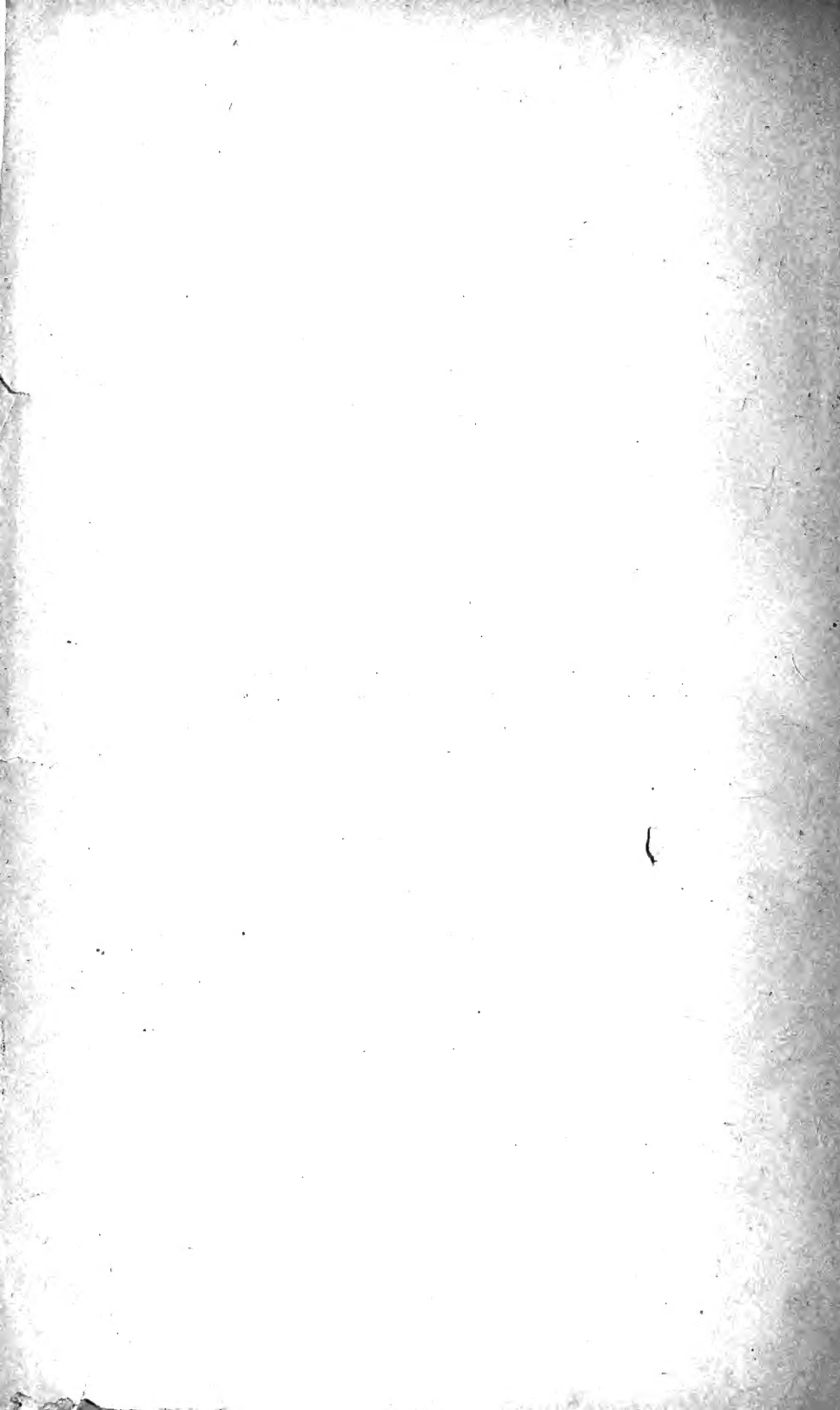

A

# MANUAL OF FORESTRY.

BY

WILLIAM SCHLICH, PH. D.,

PRINCIPAL PROFESSOR OF FORESTRY AT THE ROYAL INDIAN ENGINEERING COLLEGE,  
COOPERS HILL;

LATE INSPECTOR-GENERAL OF FORESTS TO THE GOVERNMENT OF INDIA.

## VOLUME II.

FORMATION AND TENDING OF WOODS,

OR

PRACTICAL SYLVICULTURE.

WITH 80 ILLUSTRATIONS.

**LIBRARY**  
FACULTY OF FORESTRY  
UNIVERSITY OF TORONTO

LONDON :

BRADBURY, AGNEW & CO. LD., 8, 9, 10, BOUVERIE STREET.

1891.

93742  
—  
2419108

LONDON:  
BRADBURY, AGNEW, & CO. LIMD., PRINTERS, WHITEFRIARS.

SD  
371  
533  
1906  
v.2



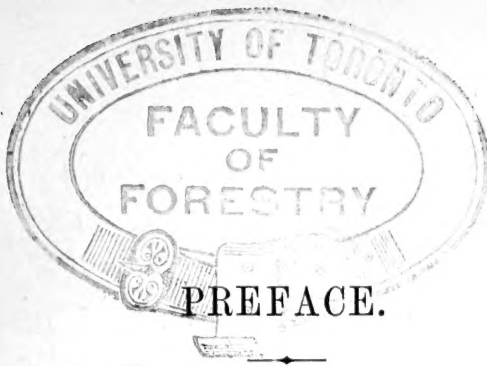

THE first volume of this Manual, which appeared in the autumn of 1889, deals, in Part I., with the general utility of forests and, in Part II., with the fundamental principles of Sylviculture. The present volume, comprising Part III., describes the practical application of those principles, and Parts II. and III. together form a Manual of Sylviculture. The remaining parts of the Manual of Forestry will deal with separate matters.

In writing the two volumes I discarded the idea of striving after absolute completeness; my object was to give only the important points, and to exclude less important or doubtful matter, so as to prevent the former from being obscured, and to keep the size of the book within reasonable limits.

My sincere thanks are due to my friend and colleague, Mr. W. R. Fisher, for the valuable assistance which he has afforded to me in the correction of the manuscript and in passing it through the press.

I am greatly indebted to Professor Marshall Ward,

F.R.S., for the Appendix to Chapter IV., giving botanical notes on British forest trees ; they will be useful to students.

I desire, further, to thank Mr. W. F. H. Blandford, Lecturer on Entomology at Coopers Hill College, for the short notes on the principal insects injurious to forest trees in England, which have been incorporated into Chapter IV.

In the preparation of this volume I consulted most of the leading works on Sylviculture. Amongst these the following require to be specially mentioned :—

- (1.) Brown, "The Forester."
- (2.) Heyer, "Der Waldbau."
- (3.) Gayer, " " "
- (4.) Hess, "Die Eigenschaften und das forstliche Verhalten der wichtigeren in Deutschland vorkommenden Holzarten."

Hooker's Student's Flora of the British Islands has guided me as regards the distribution of the indigenous British forest trees.

W. SCHLICH.

COOPERS HILL,  
24th April, 1891.

# TABLE OF CONTENTS.

---

PREFACE . . . . .	PAGE v
-------------------	-----------

---

## PART III.

### FORMATION AND TENDING OF WOODS.

INTRODUCTION . . . . .	3
------------------------	---

#### CHAPTER I.

PRELIMINARY WORKS. . . . .	4
----------------------------	---

SECTION I.—CHOICE OF SPECIES . . . . .	4
--	---

SECTION II.—FENCING. . . . .	12
------------------------------	----

SECTION III.—RECLAMATION OF THE SOIL . . . . .	20
--	----

1. Treatment of an Impermeable Substratum . . . . .	21
---	----

2. Treatment of Swampy Ground generally . . . . .	23
---	----

3. Irrigation of Arid Land . . . . .	30
--------------------------------------	----

4. Treatment of Excessive Accumulations of Vegetable Matter . . . . .	31
---	----

5. Fixation of Shifting Sands . . . . .	33
---	----

6. Fixation of Unstable Soil on Slopes . . . . .	38
--	----

#### CHAPTER II.

FORMATION OF WOODS . . . . .	40
------------------------------	----

SECTION I.—ARTIFICIAL FORMATION OF WOODS . . . . .	41
--	----

A. Direct Sowing . . . . .	41
----------------------------	----

I. <i>Conditions of Success</i> . . . . .	41
---	----

1. Choice of Species . . . . .	41
--------------------------------	----

	PAGE
2. Quality of Seed . . . . .	41
3. Quantity of Seed . . . . .	46
4. Conditions of Germination . . . . .	48
II. <i>Methods of Sowing</i> . . . . .	56
1. Broadcast Sowing . . . . .	56
2. Partial Sowing . . . . .	62
<b>B. Planting</b> . . . . .	<b>70</b>
I. <i>Conditions of Success</i> . . . . .	70
1. Choice of Species . . . . .	71
2. Different Kinds of Plants . . . . .	71
3. Quality of Plants . . . . .	72
4. Age and Size of Plants . . . . .	74
5. Season for Planting . . . . .	74
6. Density of Planting . . . . .	76
7. Distribution of Plants over Area . . . . .	77
8. Number of Plants . . . . .	84
9. Lifting Plants . . . . .	86
10. Pruning Plants . . . . .	90
11. Protection of Plants in Transit . . . . .	92
12. Preparation of the Soil . . . . .	94
II. <i>Raising Plants</i> . . . . .	94
1. Purchase of Plants . . . . .	95
2. Plants taken from existing Woods . . . . .	96
3. Raising Plants in Nurseries . . . . .	97
III. <i>Methods of Planting</i> . . . . .	117
1. Planting with Balls of Earth . . . . .	118
2. Planting without Balls of Earth . . . . .	120
3. Mound Planting . . . . .	128
IV <i>Planting with Slips, Layers and suckers</i> . . . . .	129

	PAGE
SECTION II.—NATURAL REGENERATION OF WOODS . . . . .	132
<b>A. Natural Regeneration by Seed</b> . . . . .	132
I. <i>Natural Regeneration under Shelter-woods</i> . . . . .	132
1. The Compartment System . . . . .	135
<i>a.</i> Preparatory Stage. . . . .	136
<i>b.</i> Seeding Stage . . . . .	141
<i>c.</i> Final Stage . . . . .	144
<i>d.</i> Marking the Trees for Removal . . . . .	149
2. The Strip System . . . . .	150
3. The Group System . . . . .	152
4. The Selection System . . . . .	157
5. Comparative Merits of the four Systems . . . . .	158
II. <i>Natural Regeneration from Adjoining Woods</i> . . . . .	161
<b>B. Natural Regeneration by Shoots and Suckers</b> . . . . .	164
SECTION III.—CHOICE OF METHOD OF FORMATION . . . . .	169
<b>A. Choice between Direct Sowing and Planting</b> . . . . .	170
<b>B. Choice between Artificial Regeneration, and Natural Re-         generation by Seed</b> . . . . .	175
<b>C. Combination of Several Methods of Formation</b> . . . . .	178
SECTION IV.—FORMATION OF MIXED WOODS . . . . .	180
1. Even-aged Mixed Woods . . . . .	181
2. Uneven-aged Mixed Woods . . . . .	185

CHAPTER III.

TENDING OF WOODS . . . . . 189

SECTION I.—TENDING OF WOODS DURING EARLY YOUTH . . . . .	192
1. Protection against External Dangers . . . . .	192
2. Preservation of a proper Density of the Crop . . . . .	195
3. Cleaning of Young Woods . . . . .	196
4. Preservation of a proper Mixture . . . . .	197



CONTENTS.

xi

	PAGE
10. Willow . . . . .	271
11. Poplar . . . . .	275
12. Lime-tree . . . . .	278
13. Hazel . . . . .	281
14. Silver Fir . . . . .	283
15. Common or Norway Spruce . . . . .	290
16. Scotch Pine . . . . .	296
17. Black or Austrian Pine . . . . .	303
18. Weymouth Pine . . . . .	306
19. Larch . . . . .	309
20. Douglas Fir . . . . .	316

APPENDIX TO CHAPTER IV.

NOTES ON BOTANICAL CHARACTERS SERVING TO DISTINGUISH THE PRINCIPAL BRITISH FOREST TREES . . . . .	323
---	-----

---

INDEX . . . . .	345
-----------------	-----

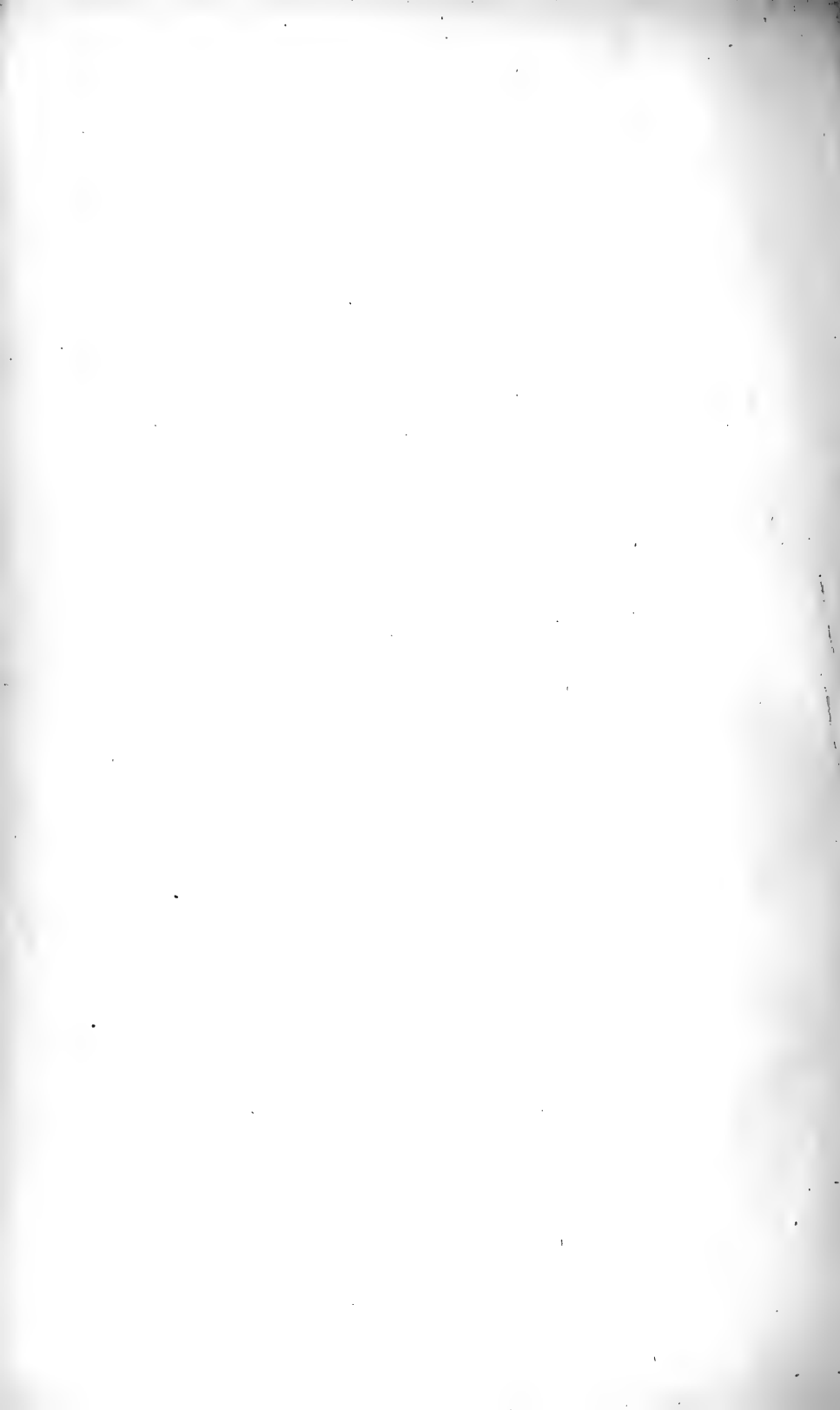



PART III.

FORMATION AND TENDING OF WOODS.

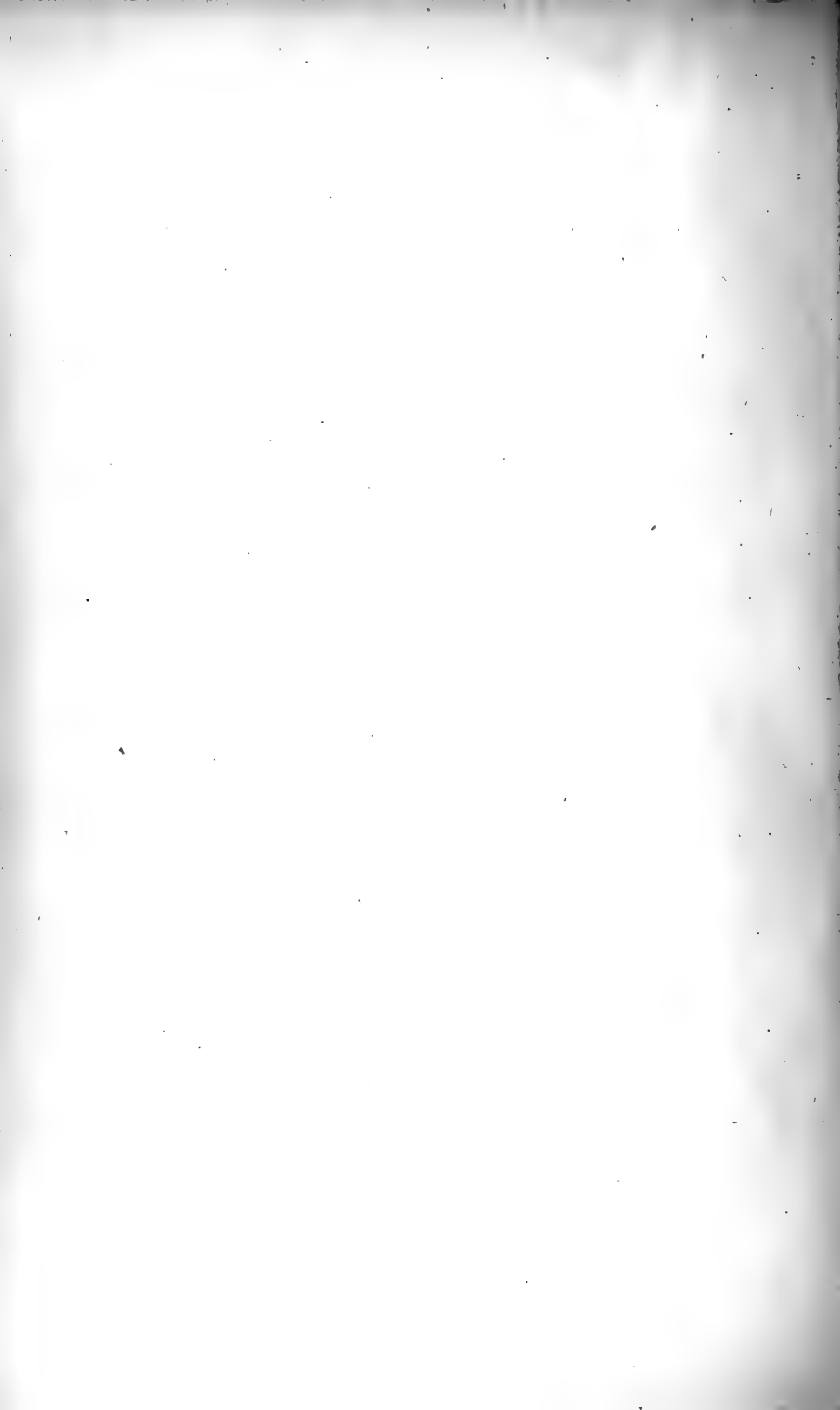

# MANUAL OF FORESTRY.

---

## INTRODUCTION.

THE present volume deals with Practical Sylviculture. Under that term is understood \* the production of woods or forests, that is to say all operations connected with the formation and tending of woods until they become ripe for the axe. The fundamental principles which guide the forester in this business have been explained in Part II. of this Manual; it now remains to apply them to Practical Sylviculture.

The subject has been divided into the following chapters:—

- CHAPTER I.—PRELIMINARY WORKS.
- „ II.—FORMATION OF WOODS, EITHER BY  
ARTIFICIAL OR NATURAL MEANS.
- „ III.—TENDING OF WOODS.
- „ IV.—SYLVICULTURAL NOTES ON BRITISH  
FOREST TREES.

\* See page 99 of Volume I. of this Manual.

## CHAPTER I.

### PRELIMINARY WORKS.

BEFORE a wood can be formed certain preliminary matters must be attended to. These will be indicated in the following three sections:—

- Section I.—Choice of species.  
 „ II.—Fencing.  
 „ III.—Reclamation of the soil.

### SECTION I.—CHOICE OF SPECIES.

The success of Forestry depends in the first place upon a judicious selection of the species of tree which is to be grown under a given set of conditions. A full consideration of this matter is of great importance, because mistakes made in the selection of species cannot, as a rule, be rectified until after a considerable lapse of time. Most indigenous species thrive almost equally well on ordinary soils for a series of years, while those unsuited for a particular locality only commence falling off after perhaps 20, 30 or even more years.

The full success of a species depends on many things, amongst which the following deserve special attention:—

1. Suitability for the objects of management.
2. Adaptability to the desired sylvicultural system.

3. Exposure to damage by external causes.
4. Faculty for preserving or even improving the fertility of the soil.  
    To which may be added,
5. Desirability, or otherwise, of a periodical change of species.

1. *Suitability of the Species for the Objects of Management.*

The varying objects of management have been indicated on page 99 of Volume I. Whatever, in any special case, they may be, the species must be selected so as to do them full justice.

If the object is to grow produce of a definite description, the species must be capable of yielding it; it would be useless to grow Yew for hop poles, or Poplar for naval construction. Where the objects of management are governed, or influenced, by existing forest rights demanding timber or firewood of a particular species, that tree must be grown. If, on the other hand, third persons are entitled to trees of certain species, should they happen to appear on the area, the owner would not voluntarily cultivate them.

Where the object is to produce the greatest possible quantity of material per unit of area, that species must be selected which produces the highest average annual increment.\*

In gauging the financial desirability of a species, the quantity and quality of the produce, as well as the expense of rearing it, must be taken into account. In

\* See page 166 of Volume I.

some cases, only certain species are saleable, while others are without value. Again, some species produce a much higher percentage of timber than others.

Species with a thin crown are indifferently adapted for wind-breaks, whereas they may be specially suited for nurses over a tender crop.

The above instances will suffice to show that, the number of species which may be desirable in any given case, is narrowed down by the objects of management.

## 2. *Adaptability of the Species to the desired Sylvicultural System.*

All species of trees can be treated as high forest, but only a certain number as coppice woods. The conifers of temperate Europe either do not coppice at all, or very indifferently; even some of the broad-leaved species do not yield satisfactory results.\* A selection of species must be made accordingly.

## 3. *Exposure of Species to damage by External Causes.*

The selection of species to be planted is further narrowed by the degree to which they are exposed to injury by external causes, as fire, frost, drought, cold winds, strong gales, insects and fungi. Conifers, for instance, are more exposed to damage by fire than broad-leaved species; Larch and Silver Fir suffer much from cancer; Spruce is liable to be thrown by wind; Beech and Silver Fir are frost-tender, while Scotch Pine and Birch are frost-hardy; Scotch Pine and Spruce are more

\* See page 174 of Volume I.

subject to damage by insects than any other European species, &c. All these matters influence the choice of species under a given set of conditions.

#### 4. *Capacity of Species to preserve or improve the Fertility of the Locality.*

From the point of view of Political Economy the improvement, or at any rate the maintenance, of the yield capacity of the land is the most important consideration. Whether the owner of a forest be the State or a private person, he will find a system of management recognizing that principle to be the most profitable in the long run. Hence it must be the forester's endeavour to grow species not only suited to the locality, but also tending to improve it.\*

In the first place the *quality* of the locality must be carefully ascertained, so as to avoid growing a species which has no chance of thriving on it. This task is by no means an easy one, because the effects on tree growth of some of the factors of the locality are as yet imperfectly understood. The climatic factors are of special importance; hence the effects of the geographical position, altitude, aspect, gradient, contour and surroundings of the locality upon the temperature, degree of moisture, and air currents must be carefully considered. The soil, and, if necessary, the subsoil as well must be examined as to depth, degree of porosity and moisture, composition and admixture of humus. The development of any trees already growing on the locality, or in its vicinity, should be carefully studied.† An investigation of this kind will

\* See Chapter I. of Part. II. of Volume I., especially pages 137—150.

† See pages 150—157 of Volume I.

generally indicate what species are capable of thriving on a locality; it should however not be overlooked that any species found growing naturally on the area are not always those best adapted for it, because their presence may depend on circumstances other than a general suitability of soil and climate: for instance, a shade-bearing species may have ousted a light-demanding one, or a greater power of reproduction may have enabled one species to drive out another possessed of a smaller energy in that respect.

As long as the factors of the locality are fairly the same over the whole area, the latter may be treated in a uniform manner, but the occurrence of decided differences may necessitate the selection of different species for different parts. Any attempt at uniformity in spite of such differences may lead to a serious loss in returns.

In order to provide for a continuous preservation of the fertility of the locality, it is necessary to select species which give sufficient shelter to the soil and a good supply of humus.\* This rule can only be disregarded in thoroughly favourable localities. Under these circumstances, species with dense crowns must receive special attention in making a selection for middling and inferior localities; in addition, interference with the fertility of the soil, such as the removal of leaf-mould, excessive grazing, faulty treatment, &c., must be carefully avoided. Above all, personal fancy on the part of the forester for a particular species must be set aside.

Not unfrequently several species are found to be equally well adapted for a locality. In such cases other

\* See page 145 of Volume I.



considerations must decide which shall be grown, or whether a mixed wood is preferable.

Owing to the great variety of the factors of the locality, the task of selection is frequently rendered difficult. On fertile deep fresh soil almost any species will thrive. Again, where the locality has such a decided character that only one or two species are admissible, the choice is easy enough; for instance deep dry sand points to the cultivation of the Scotch or Austrian Pine, wet soil to that of the Alder. Where, however, the fertility of soil has deteriorated, for instance by the continued removal of litter, or where damage by fire, frost, drought, snow, storms and insects may be apprehended, it is often difficult to hit on the most suitable species.

Frequently the factors of the locality do not exactly correspond with the requirements of any species, so that the power of accommodation becomes an important element. This power in the case of some species is confined within narrow limits, while others can adapt themselves to all sorts of conditions. For instance, Scotch Pine and Birch are very accommodating as regards soil and climate; Spruce, Beech, and Silver Fir are less accommodating, and still less so are the Maples, Alder and Ash. Sometimes the power of accommodation depends chiefly on one factor; if that is not present the species will not thrive. Taking for instance the temperature, Sweet Chestnut and Elm are exacting, while Scotch Pine is the reverse. Oak and Alder require particular degrees of moisture in the soil, while Birch and Scotch Pine are not particular. Spruce prefers moist air, &c.

### 5. *Change of Species.*

The question deserves to be mentioned here, whether in Sylviculture a change of species is advisable, or not, at the end of successive rotations. Change of crops is practised in agriculture, because different species make different demands on the soil. By changing the crop annually more time is given for the accumulation of the substances which a particular species may require. In the same way it has been suggested that better results might be obtained in Sylviculture by a change of species, especially as certain phenomena seemed to support such a view. It has been observed, for instance, that coniferous trees here and there supplant broad-leaved species, that Spruce frequently usurps the place of Silver Fir, and Birch that of Scotch Pine, or that exacting species no longer thrive in certain localities.

On a close investigation such a theory will be found untenable except on poor soils. Timber trees take comparatively small quantities of mineral substances from the soil, if the leaf-mould be not removed; in fact, only about one-twelfth of the total quantity required by field crops, and about one-twentieth of the rarer substances,\* so that all except poor soils can go on providing the necessary quantum of mineral matter for any length of time. The trees protect the soil by their foliage, whilst the fallen leaves afford a substantial amount of organic matter, in addition to the inorganic materials previously taken from the soil. This amount may be so considerable that an increase of fertility may be actually produced. If, nevertheless, in some

\* See pages 140—143 of Volume I.

cases a reduction of the fertility should be observed, it will be due to insufficient shelter afforded by trees with thin crowns, to heavy removals of litter, faulty treatment, fires, or other causes.

The fact that one species sometimes supplants another is generally due to its greater reproductive power, or its greater resisting power against external influences. For instance, the felling of a Spruce or Scotch Pine wood may be followed by the appearance of large numbers of insects, which breed in the stools of the trees left in the ground, and destroy any young crop of these species which may spring up; other species not subject to such attacks may then occupy the ground, if allowed to do so.

As a rule in Sylviculture a change of species is only called for in special cases, such as:—

- (1.) When the original species has, on general grounds, been found unsuited for the locality.
- (2.) When an inferior species is to be replaced by a more valuable one.
- (3.) When the fertility of the soil, in consequence of faulty treatment, heavy removal of litter, &c., has deteriorated, so that the original species will no longer thrive on it, and must give way to one less exacting.
- (4.) When a temporary shelter-wood (nurses) is required for a tender species.
- (5.) When the object is to extend the growth of one species uniformly over a certain area.

## SECTION II.—FENCING.

Fencing is used for nurseries and woods. Whether it is required for the latter depends on the extent to which a particular species is exposed to attacks by cattle or game. Erecting fences is ordinarily one of the heaviest items of expense in the formation of woods, and it is essential to select in each case that kind which, while meeting the necessary requirements, involves a minimum outlay.

The number of different kinds of fences which are in use or have been suggested is very great. It is not intended to describe these here in detail, as a practical knowledge can only be obtained out of doors. It will suffice to enumerate the principal kinds, and to give illustrations of a few, which seem specially adapted for silvicultural purposes.\*

1. *Hedges.*

Hedges are formed of a great variety of trees and shrubs, of which, for temperate Europe, the following may be mentioned: Hawthorn, Blackthorn, Beech, Furze, Holly, Laurel, Yew, Box, Privet, Barberry, Hornbeam, Birch, Elder, Spruce and Silver Fir. For silvicultural purposes Hawthorn, Beech, Hornbeam and Spruce are perhaps most to be recommended. Several years will elapse, however, before they can protect an area efficiently against cattle or game; hence they must either be planted beforehand,

\* A detailed account of fences will be found in "The Forester," by James Brown, 5th edition, pages 98—170.

or augmented by a temporary fence of some other kind.

Fig. 1 represents a cross section of a wedge-shaped thorn hedge (after Brown).

Fig. 2 shows a longitudinal section of a thorn hedge (after Heyer); each plant has been coppiced near the ground; of the shoots which appeared, two were left on

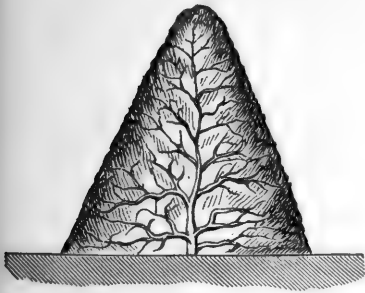

Fig. 1.

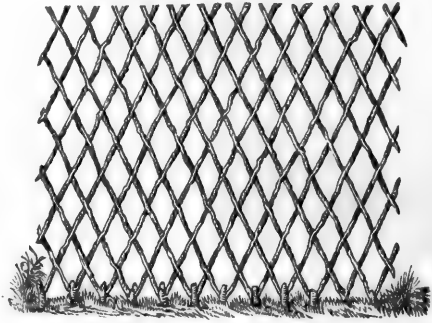

Fig. 2.

each stool, trained to opposite sides and interlaced. Such a hedge can be made to keep out hares and rabbits.

Living hedges are, in Forestry, only used for nurseries or along roads leading to pastures.

## 2. Walls.

These may be dry stone walls, or they may be constructed with mortar. The former are liable to fall, and the latter are very expensive. Walls generally interfere with the free circulation of air; in some cases this may be desirable for the purpose of protecting tender plants against cold air currents.

Turf dykes are walls constructed of turf; they can replace stone walls, where turf is abundant and stones are rare; at the same time they are of a perishable

nature. In the accompanying Fig. 3 (after Brown) the natural surface line is represented by *a, a, a, a*, while

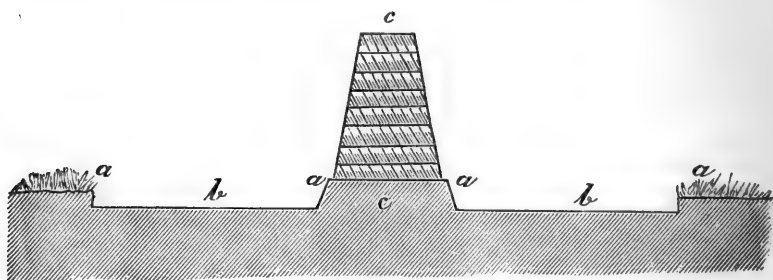

Fig. 3.

*b, b* are the places where the turf has been excavated, and *c, c* the dyke consisting of successive layers of turf.

### 3. *Wooden Palings.*

There is an endless variety of construction for wooden palings.

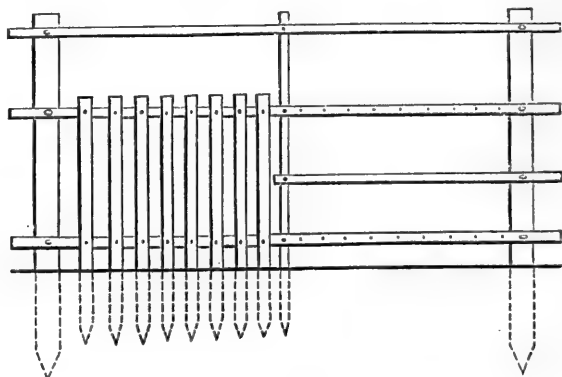

Fig. 4.

Fig. 4 shows a wooden fence, affording protection against rabbits on one half of the diagram. It suffers

under the disadvantage that all the upright spars must be driven into the ground, which causes them to rot. To reduce this danger the inserted part should be tarred or creosoted. It is far better to replace the short spars by wire netting.

#### 4. *Ditches.*

Ditches for keeping out animals should be constructed with a perpendicular wall (*a*) on the inside and a gentle slope (*b*) outwards (Fig. 5); sometimes the perpendicular side is faced by a stone wall (*c*) to prevent its falling in. On the whole ditches are expensive, if constructed so as to be lasting; hence in the majority of cases they are only used as an auxiliary to other fences, for instance a wooden paling or a wire fence (*d*).

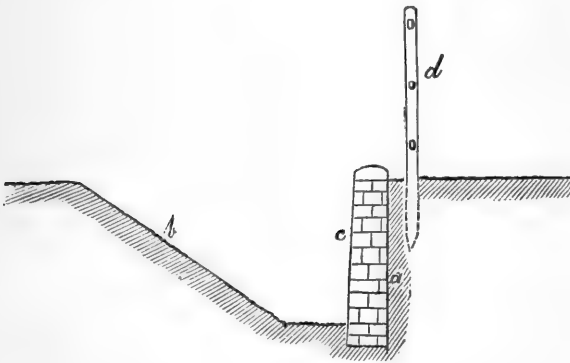

Fig. 5.

slope (*b*) outwards (Fig. 5); sometimes the perpendicular side is faced by a stone wall (*c*) to prevent its falling in. On the whole ditches are expensive, if constructed so as to be lasting; hence in the majority of cases they are only used as an auxiliary to other fences, for instance a wooden paling or a wire fence (*d*).

#### 5. *Wire Fences.*

Here, again, a great many varieties have been introduced, some having iron standards and others wooden

supports. In the case of permanent nurseries iron standards may be desirable, but in fencing woods, which only require protection for a limited number of years while under regeneration, wooden supports will, in the majority of cases, be found cheaper. On the whole, for silvicultural purposes, wire fences with wooden supports are probably more suitable than any other kind.

Fig. 6 represents a fence consisting of wooden supports, with six wires so arranged as to keep out horned

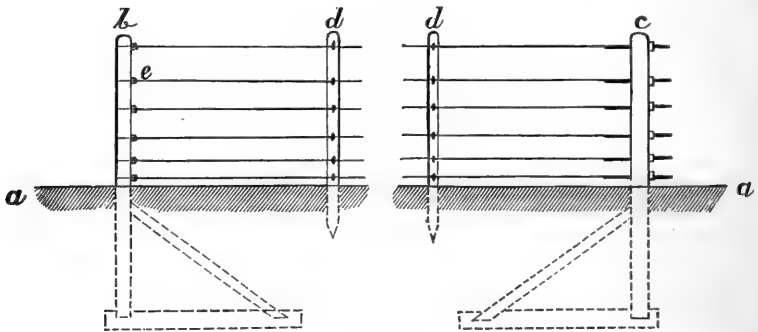

Fig. 6.

cattle, horses and sheep; height 4 feet. *a - - - a* shows the surface of the soil; *b* and *c* the two end or straining posts of a section, which should not be further apart than 600 feet; *d* and *d* represent intermediate thinner posts, placed from 5 to 10 feet apart; *b* and *c* have each 6 holes bored into them. At *b* the ends of the wires are passed through these holes, bent round the post, and fastened securely to the wires at *e*. At the other straining post *c*, the wires are strained and fastened by various contrivances, one of which is shown in the illustration. It consists of a screwed eye-bolt not less than 12 inches long. The



end of the wire is fastened to the eye of the bolt (Fig. 7, *a*), and the latter passed through the hole in the straining post. On the other side a nut *b* is screwed on



Fig. 7.

after first inserting a plate or washer *c*, to prevent the nut from cutting into the wood. By turning the nut sufficiently the wire becomes strained. The wires are fastened to the intermediate posts by staples (Fig. 8).



Fig. 8.

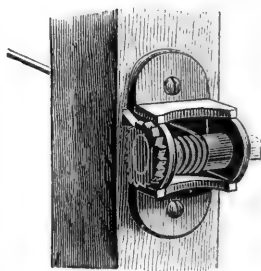

Fig. 9.

These are driven half way into the posts, and the wires passed through before the straining commences. They are driven home when the straining has been completed.

Fig. 9 shows a cast-iron straining bracket fastened to a wooden pillar; this is worked with a key. It is used instead of the eye-bolt.

Where rabbits or hares are to be kept out, wire netting may be added to the lower part of the fence.

The cost of the materials in England is at present as follows:—

Wire, imperial standard wire gauge, No. 8, about one shilling per 100 feet; galvanized,  $\frac{1}{3}$  more. Straining bolts, 12 inches long,  $\frac{5}{8}$  inch diameter, with nut and washer, tenpence each. Straining brackets (Fig. 9), tenpence each. Steel staples, per 1000, = 9s.; galvanized,  $\frac{1}{3}$  more. Thus the iron materials come to about 3*d.* a yard, or 4*d.* if galvanized wire and staples are used. The cost of the posts and of labour depends on local circumstances.

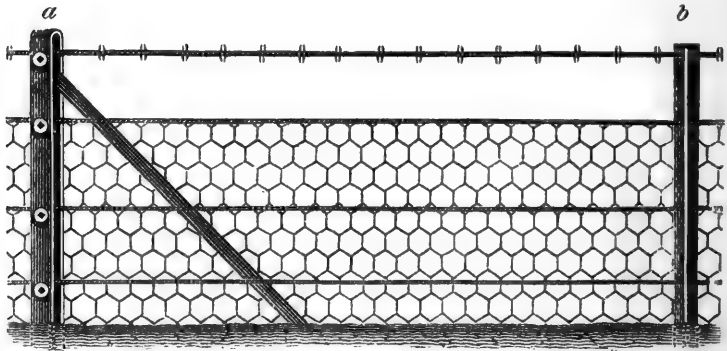

Fig. 10.

For nurseries iron fences may be used, to which wire netting may be added if necessary. Fig. 10 represents such a fence. It is 4 feet high,  $2\frac{1}{2}$  feet in the ground, and strong enough to keep out horned cattle, sheep, goats, hares and rabbits. The straining pillars, *a*, are so arranged as to strain the wires on both sides; they are usually, in this fence, placed 220 yards apart. The standards, *b*, are tee irons,  $1\frac{1}{2}'' \times 1\frac{1}{2}'' \times \frac{3}{16}''$  placed 12 feet apart. The top wire is galvanized barb No. 4, the three lower wires No. 6 galvanized strand. The netting is  $1\frac{1}{2}$  inches mesh, medium quality; it reaches  $3\frac{1}{2}$  feet above

ground, and is pegged down 6 inches along the surface outside, to prevent rabbits burrowing under it. This fence is offered in the London market for 1s. 4½d. a yard.\*

#### 6. *Combinations.*

Frequently two kinds of fences are combined. More particularly wooden palings or wire fences and even turf dykes and walls may be added to ditches, or walls and turf dykes may carry a wire fence or a wooden paling (see Fig. 5 at page 15).

#### 7. *Choice of Fence.*

The choice of fence depends chiefly on:

- (1.) The time during which it is required.
- (2.) The species of animal to be kept out.

If an area is to be protected permanently, or at any rate during a considerable period of time, the fences should be of a substantial nature, such as living hedges, wire fences with iron standards, or stone walls. For a limited number of years, wooden palings, wire fences with rough wooden standards, or turf dykes will be cheaper.

Protection may be provided against horned cattle, horses, sheep, goats and deer, by any of the above-mentioned fences. Where hares and rabbits are to be excluded, wire fences and often also hedges and wooden palings require the addition of wire netting, or a similarly effective arrangement. In the case of rabbits the wire netting must go from 6 to 12 inches below the surface; a still better arrangement is to lay it flat on

\* By the Iron Wire Wire Rope, and Fencing Company, London, Westminster.

the surface on the outside for 6 to 12 inches and cover it lightly with soil.

Against ordinary cattle a height of 4 feet is sufficient, but against deer the fence should be 6 and even 7 feet high.

### SECTION III.—RECLAMATION OF THE SOIL.

Soil may be called fertile for silvicultural purposes, if it possess sufficient depth, a suitable degree of porosity and moisture, and a suitable chemical composition.\* Forest soil, if undisturbed, will in most cases maintain, or even acquire, those physical conditions which render regular artificial tillage unnecessary.† Immediately before and during the formation of a wood, however, certain things may have to be done to render the soil fit for the growth of trees, and to enable the latter to make a start. These measures may be divided into the following two groups:—

- (a.) Reclamation of soil unfit for the growth of trees,  
and
- (b.) Tillage of the soil concurrent with the formation  
of a wood.

The latter will be dealt with in connection with the various methods of starting a wood. Group (a) includes the following measures:—

1. Treatment of an impermeable substratum.
2. Treatment of swampy ground generally.
3. Irrigation of arid ground.
4. Treatment of excessive layers of vegetable matter.

\* See page 137 of Volume I.

† See pages 20 and 145 of Volume I.

5. Fixation of shifting sand.

6. Fixation of unstable soil on slopes.

It would require a volume to itself to deal exhaustively with these matters; hence, in this place, only a few short remarks can be made on the more important points. Those who require more detailed information will find it in special works on the several subjects.

### 1. *Treatment of an Impermeable Substratum.*

Impermeable strata in the soil consist in some cases of an accumulation of clay, which has by degrees been washed out of the surface layers and deposited at a certain depth; in other cases, sand or gravel has been converted into a hard rock-like mass by the addition of organic matter, clay, or oxide of iron. Such a stratum is frequently called a *pan*. It may be found at varying depths below the surface; if at a depth of 4 feet or more, it does not, as a rule, interfere with the growth of forest trees, except perhaps on arid unirrigated ground, but if it occurs nearer the surface it may produce the following injurious effects:—

(a.) Interference with the development of a proper root system, followed by small height-growth and liability of the trees to be thrown by strong winds.

(b.) Interference with the movement of water in the soil, preventing its penetration into the sub-soil during wet weather, and its ascent during dry weather; in other words it may render the soil too wet at one time and too dry at another.

The remedy is to break through the impermeable stratum, so as to connect the upper and lower permeable layers of the soil. According to the nature of the pan and its depth below the surface one of the following methods of treatment must be adopted :—

- (a.) Deep ploughing.
- (b.) Trenching.
- (c.) Raising the surface-level.

If the lowest part of the pan is not deeper than 2 feet below the surface and not too hard, ploughing may be adopted; the pan, being brought to the surface and exposed to the atmosphere, soon disintegrates. Pans situated at a greater depth than 2 feet must be broken through by trenching with spade, hoe, pick, or crow-bar. In either case the operation is expensive, hence it is usual to treat only part of the area, in strips, patches, or holes. Strips may be 2 to 3 feet broad, separated by unbroken ground 4 to 6 feet in breadth, so that the actual work is restricted to about one-third of the area. Patches may be of various size, down to holes about 12 inches square.

If the pan is very thick and goes to a greater depth than 3 feet, it may be cheaper to raise a portion of the land by cutting ditches at intervals and placing the excavated earth on the intermediate strips, thus providing the latter with a depth of soil sufficient for the production of trees.

The treatment of impermeable strata is always an expensive matter, so much so in many cases that the utilization of the area becomes altogether unprofitable. In some cases the expense may be avoided, by planting

a shallow-rooted species and being satisfied with moderate returns.

## 2. *Treatment of Swampy Ground generally.*

Each species thrives best with a definite degree of moisture in the soil at all times of the year.\* That degree differs considerably in the case of the several forest trees; while some like moist and even wet soil, others will not flourish in such localities, and none of them in stagnant water. It follows that an excess of moisture over and above what is suitable for a given species must be removed, before a wood is started. The method of doing this depends on the cause of the excess of moisture.

A locality becomes swampy if it receives more water than can be disposed of by evaporation, filtering into the subsoil, or surface drainage. An excess of water may be due to excessive rainfall, inundation, underground currents, or springs; in the first two cases the swampiness may be only temporary. The natural draining away of the excess water may be impeded by an insufficient local gradient, by an impermeable soil, or by both combined, the last being the usual case.

Before removing the surplus water from a swampy piece of ground, the expense and the effect of drainage on the surrounding lands should be carefully considered. The cost is, as a rule, considerable, and sometimes prohibitive: draining a swamp may seriously reduce the necessary degree of moisture of adjoining areas, especially in a hilly country; the level of underground water;

\* See pages 130 and 139 of Volume I.

the continuous flow of water in the ordinary water channels, or even the amount of rain and dew in the neighbourhood. In this manner, existing woods, which have become accustomed to a certain degree of moisture, may be seriously injured.\*

If, after full consideration, it has been decided to remove the excess water, this can be done either by diverting the water before it reaches the swampy ground, or by draining the latter.

*a. Diversion of Excess Water.*

This is done by embankments in the case of inundation water coming from rivers in low lands, or by ditches in the case of spring water or surface drainage coming from higher ground.

Inundation water moving over the surface of the land may be kept out of a certain locality by a surface embankment; if the water moves underground, it can only be stopped by a substantial underground embankment, such as a stone or concrete wall.

Spring water and surface drainage in hilly ground is caught and diverted by running a ditch of suitable dimensions along the slope of the hill just above the swampy ground. The ditch intercepts the water and leads it past the swamp. In some cases the mouth of the spring is situated in the swampy ground itself, when only draining can meet the evil.

\* It is believed that some of the Elms in the Long Walk, Great Windsor Park, died in consequence of drainage carried out some years ago; after these drains had, in consequence, been blocked again, the remaining trees recovered.



*b. Drainage.*

A swamp may be drained :—

(1.) By increasing the gradient (or width) of existing watercourses. This is practicable when the latter pursue a winding course; in such a case the course may be straightened, so as to increase the velocity of the current. This method is only occasionally applicable.

(2.) By breaking through an impermeable stratum in the soil, so that the water can filter into the subsoil

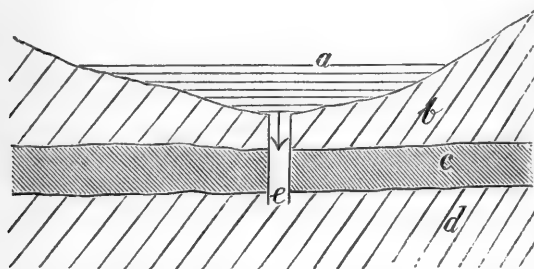

Fig. 11.

(Fig. 11). Here *a* represents the water, *b* and *d* permeable strata, and *c* an impermeable stratum; *e*, the channel leading from the swamp to the lower permeable stratum.

(3.) By constructing a series of ditches, or laying down a series of drainage pipes. The latter are rarely used in forestry, because they are expensive and liable to be choked by the roots of the trees. For the same reasons covered ditches are only rarely employed. The method usually followed consists in the construction of a series of open ditches, because they are comparatively cheap, whilst setting aside a

portion of the area for ditches does not reduce the returns.

There may be three kinds of ditches:—

- (a.) The collecting ditches, or feeders ;
- (b.) The connecting ditches, or leaders ;
- (c.) The main drain.

See Fig. 12.

The feeders receive the water from the soil and conduct it to the leaders, whence it is taken into the main drain. In some cases the feeders fall directly into the main drain.

The *first step* in proceeding to drain an area is to take levels, so as to ascertain accurately the fall of the locality ; if the area is of some extent, a map showing contour lines should be constructed. Unless this is done mistakes are likely to occur in laying out the system of drains.

The *second step* is to lay out the main drain, if possible along the natural line of drainage ; in other words, along the lowest part of the area. According to the natural fall of the land, the gradient of the main drain may have to be increased by cuttings, or reduced by giving it a winding course, so as to secure a suitable fall.

The *third step* is to lay out a system of feeders, more or less parallel to each other, at a suitable angle with the general slope of the country, and to connect them at an acute angle with the main drain, either directly or through a leader, which is similarly connected with the main drain.

In laying out such a system of drains, the gradient,

depth, shape and distance from each other require careful consideration.

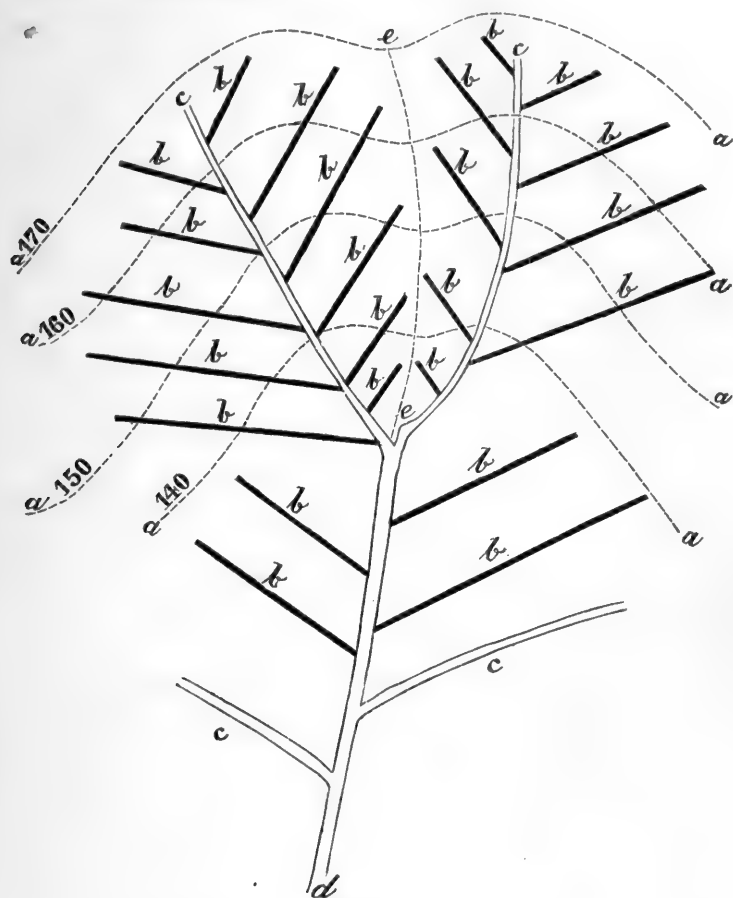

Fig. 12.

a, a. Contour lines.

e, e. Water parting.

b. Feeders.

c. Leaders.

d. Main drain.

(The figures 170, 160, 150, and 140 give the elevation in feet above sea-level.)

The *gradient*, or fall, should be such that the water is carried away with sufficient rapidity, without causing injury to the base and sides of the drains by the scouring

action of the water. Where the natural gradient of the ground is insufficient, the base of the drain must be sunk until the necessary fall has been obtained. Where it is too great, the drains must pursue a winding or zig-zag course, so as to reduce the fall; or the base and sides of the drains must be protected by a facing of stone, or fascines; in some cases the base may be terraced.

The maximum gradient which is admissible depends on the nature of the soil. Where the latter is of middling consistency an average fall of 1 per cent. would probably be indicated; on firm soil it may be greater, on loose soil smaller.

The *depth* of the feeders depends on the depth to which it is intended to drain the land; the former must be somewhat greater than the latter. The depth to which the soil requires draining may vary from 18 inches to 3 feet, according to the species to be grown. Ash, Hornbeam, and Elm can do with 18 inches, while Scotch Pine, Beech and Silver Fir, prefer soil which is drained to a depth of 3 feet.

Figs. 13 and 14 illustrate the comparative depths to which a locality is drained, and that of the feeders and leaders.

The *shape* of the drains depends on the fall and on the nature of the soil; the greater the cohesion of the latter, the steeper may be the side slopes. In the case of peat, the sides may be almost perpendicular, in stiff loam they should form an angle of about 45 degrees, and they must become more and more slanting, as the proportion of sand in the soil increases. The base of the ditch should be at least as broad as the spade

which is used in making and afterwards cleaning it. For the rest, the width of the drain depends on the body of water which has to be carried away.

The *distance* between two successive feeders depends on the permeability of the soil, the depth of the ditches,

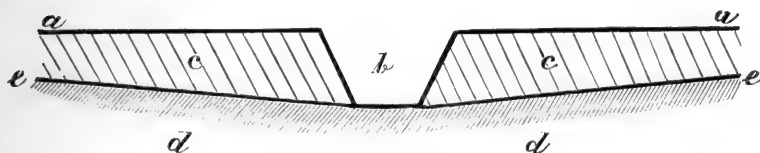

Fig. 13.

*a, a.* Natural level of ground.

*b, b.* Feeder, four feet deep.

*c, c.* Layers of soil actually drained.

*d, d.* Layers of soil not drained.

*a to e.* About three feet.



Fig. 14.

*a, a.* Natural level of ground.

*b, b.* Leaders, (five feet deep), or main drains.

*c, c.* Feeders. Depth at upper end, 3 ft. 6 in., at lower end, 4 ft. 6 in.

(In these diagrams the height is exaggerated.)

the depth to which the land is to be drained, and the general fall of the locality; it will accordingly range between 30 and 100 feet.

#### *c. Raising the Level of Part of the Ground.*

If it is undesirable or impracticable to drain a swampy area, it may, if the water stands at a moderate level, nevertheless be rendered useful, by excavating

part of it and using the soil so obtained to raise the level of the rest to a sufficient height so as to render the cultivation of trees practicable. In such cases the raised parts form generally parallel ridges, as indicated in Fig. 15.

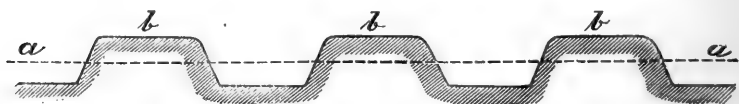

Fig. 15.

*a*—*a*. Natural level of swampy ground.  
*b*, *b*, *b*. Ridges on which the trees are to be planted.

Such works are expensive, and only species which stand a good deal of moisture can be grown.

### 3. *Irrigation of Arid Land.*

In temperate Europe irrigation is only employed in nurseries (for which see page 100), but in more southern tropical and arid countries, extensive areas are artificially irrigated for the growth of forest trees. The details of irrigation must be studied from a special work on the subject.\* In a general way, irrigation may be described as the reverse of draining; thus in Fig. 12 (page 27), *d* would represent the main supply channel, situated in the highest part of the area, *c*, *c*, *c* the leaders, and *b*, *b*, *b* the distributing trenches. The watering of the land may be caused by overflow from the trenches, or by percolation; in the latter case the trenches would only be just filled, and no more.

\* For instance "The Roorkee Treatise on Civil Engineering in India," Vol. ii., Section x.

. Where extensive areas are to be irrigated, the channels and trenches must be carefully laid out, with a suitable fall, so as to prevent the bursting of the channels and the silting up of the trenches.

#### 4. *Treatment of Excessive Accumulations of Vegetable Matter.*

Cases occur in which accumulations of vegetable matter have to be disposed of, before the formation of a wood can be taken in hand. Such accumulations may be objectionable because they are so thick that the seedlings cannot reach the mineral soil within a reasonable space of time, and run the risk of drying up; or they may have become acid, or bituminous; again they may be accompanied by swampiness, or be liable to dry up too quickly.

The following cases specially interest the forester:—

##### *a. Peat Bogs.*

To render a peat bog fit for the growth of timber trees, one or all of the following operations must be carried out:—

- (1.) Draining.
- (2.) Removal of at least a portion of the peat.
- (3.) Mixing the peat with mineral soil.

The draining is done in the manner described above; it is, however, desirable to do this gradually, so that the layers of peat may dry by slow degrees, to prevent extensive cracks from forming. The feeders should at first be of a moderate depth, and gradually deepened, until the mineral soil is reached.

When the layer of peat is shallow, it can, after draining, be mixed with the mineral soil below it, and thus rendered fit for the growth of trees; a good plan is to take one or two field crops from the area, before the trees are planted.

If the layer of peat is deep, 3 feet and more, the upper portion must be removed, and only the remainder mixed with the mineral soil. The cut peat may be used as fuel, but if not so required, it may be cheaper to burn the upper layers in situ when sufficiently dried by the draining, the ashes being mixed with the rest of the soil.

*b. Accumulation of Raw Humus.*

This may consist of an accumulation of leaves, needles, weeds, moss and twigs, which, from want of moisture in the soil, or of heat or lime, has remained undecomposed. The case only occurs in already existing woods. To cure the evil, the wood must be thinned heavily, some time before regeneration is contemplated, so as to increase the admission of sunlight and air currents and thereby the rate of decomposition. If this measure proves insufficient, part of the humus must be removed, and the rest mixed with the mineral soil.

*c. Dry Mould and Bituminous Humus.*

The first is formed by the decomposition of certain lichens on over-dry soil; the latter is the result of the decomposition of heather and various species of *Vaccinium*. Both are unsuited for young plants, and they should be removed.



On the whole the cases mentioned under *b* and *c* occur but sparingly.

### 5. *Fixation of Shifting Sands.*

Sand of a fine grain without a sufficient quantity of binding material, such as clay or humus, is liable to be blown about, and to become moving or shifting sand, which overspreads adjoining lands. If the supply is kept up, these shifting masses of sand form regular waves which proceed at a certain rate in the same direction as that of the prevailing wind. Shifting sands are most prevalent along sea shores, but also occur inland. In either case, but especially near the sea, they are capable of forming considerable accumulations of sand, reaching a height of 200 feet and even more, which are called *dunes*. Before such areas can be brought under wood, it is necessary to fix them, so as to allow trees to spring up and lay hold of the soil permanently.

#### *a. Coast Dunes.*

Along the sea coast the waves constantly throw up sand, which after drying is carried inland by air currents, forming a series of ridges and valleys, in many cases, though not necessarily, parallel to the sea shore. These sand hills move steadily forward, being replaced behind by fresh sand thrown up by the sea. The rate of progress varies considerably according to circumstances. On the west coast of France it is said to be about 14 feet a year, but as the process has gone on for a long period of time, an enormous area comprising millions of acres has become covered with sand. The

further progress of the evil has been checked only in comparatively recent times, by operations which it is useful to describe shortly in this place.

The measures which must be taken are:—

- (1.) Cutting off a further supply of sand from the sea;
- (2.) Fixing the sand temporarily, so as to allow sowing or planting;
- (3.) Growing a crop of trees and bushes, which will permanently fix the sand;
- (4.) Maintaining permanently a crop of trees and shrubs.

The first of these four measures is based on the fact that, although air currents are capable of moving the sand along level and gently sloping ground, they cannot lift it above a certain height. Hence it is necessary at a moderate distance (100—300 feet) from high-water level to form an artificial hill, which is high enough to arrest the forward movement of the sand, and this is done by the construction of an artificial dune, generally called the “littoral dune.” With this object in view a continuous line of paling is erected, consisting of planks about 6 feet long by 6 inches wide, 1 inch thick, and pointed at the lower end. The planks are inserted into the ground to about half their length, an inch apart, the direction of the line being parallel to the coast. Against this fence the sand is deposited, a certain portion being forced through the interstices and coming to rest in the comparatively quiet air immediately behind the paling. As soon as the accumulation of sand approaches the upper ends of the

planks they are pulled up about 3 feet by means of levers, and this process is repeated until the artificial dune has reached such a height that no sand can be carried over the top (see Fig. 16). Simultaneously with

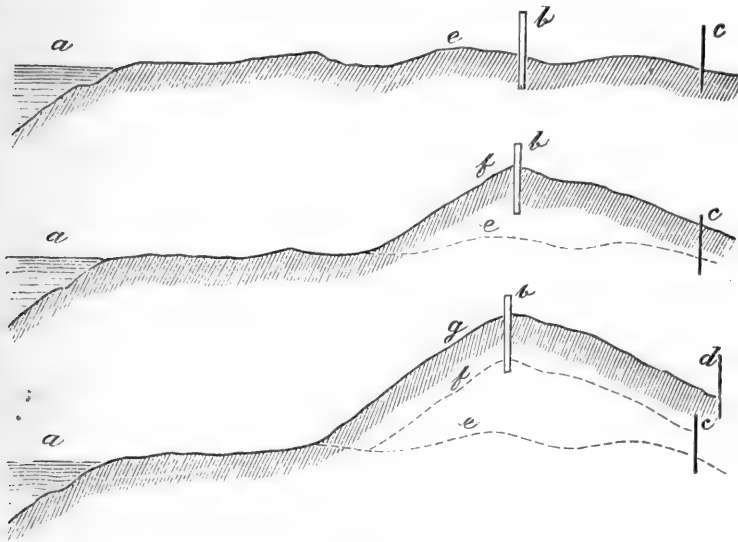

Fig. 16.

- a.* Sea level.
- b.* Piling in three successive positions.
- c.* First wattle fence.
- d.* An additional wattle fence.
- e.* Original surface of littoral dune.
- f, g.* Surface of littoral dune in two subsequent stages.

(The heights are exaggerated.)

the first erection of the piling a wattle fence is placed at a convenient distance behind it, to prevent the sand which has passed through the piling from being carried inland; when the first wattle fence has been entirely covered, a fresh one is made to replace it. In this way the dune is forced to adopt a moderate slope on both sides,

which is essential to its permanent maintenance. The latter is effected by growing on it certain plants which are capable of living under such conditions. Amongst these the Marrum-Grass, *Psamma (Ammophila) arenaria*, takes the first place; it has the property that, as the sand rises around it, its stalk grows higher and develops numerous adventitious roots at the joints. Other plants used for the same purpose are *Elymus arenarius* and *Carex arenaria*.

The second measure, or the temporary fixation of the area covered with sand behind the littoral dune, consists in covering the area with various materials, such as the branches of coniferous trees, heather, broom, furze, seaweed, turf, &c.; the last, when obtainable, is best. These materials (except the turf) are kept in their place either by fastening them down with pegs, or by placing shovelfuls of sand upon them.

The third measure consists in stocking the temporarily fixed area with trees, shrubs, and grasses. Of trees the Scotch Pine and the Cluster Pine (*Pinus Pinaster*) are specially adapted; seed of these may be sown or transplants put in. Of other plants *Psamma arenaria*, *Elymus arenarius*, *Carex arenaria*, Broom (*Sarothamnus scoparius*), and Furze (*Ulex nana*), may be mentioned. It is essential to maintain the temporary cover until it is replaced by the permanent growth.

On the west coast of France the second and third measures are done simultaneously. There, a mixture consisting of 98 pounds of Cluster Pine seed, 8 pounds of Broom, and  $3\frac{1}{2}$  pounds of *Psamma arenaria* per acre are sown, and immediately after it the ground is covered

with brushwood, which is kept in its place by occasional shovelfuls of sand. The pines, the broom, and the Marrum-grass come up together, and it is said that the young Pines grow all the better when surrounded by the two other species.

The cost of these operations is considerable, amounting sometimes to ten pounds per acre and more; the expenditure will not be found excessive if it is remembered that fertile lands beyond the dunes may thus be protected against being buried in sand.

*b. Inland Dunes.*

These are treated in a manner similar to that described in the case of coast dunes, with this exception, that the construction of a forward dune, corresponding to the littoral dune on a sea shore, may not be necessary. In many cases it may suffice to arrest the forward movement of the sand on the windward side by a wattle fence until the ground has been covered with a growth of trees, shrubs, and grasses.

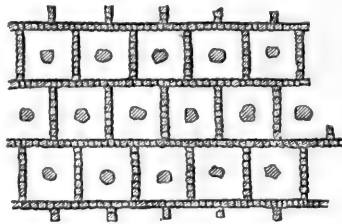

Fig. 17.

The temporary fixation of the sand is here frequently effected by means of pieces of turf, which are laid in rows or squares, within which the sowing or planting is done (Fig. 17).

In the case of both coast and inland dunes it is essential to keep all domestic animals out of the area, at any rate for a number of years after it has been fixed, as they

disturb the sand. When the area has been stocked with trees, clear cuttings must be strictly avoided, the wood being treated under the selection system, else the work may have to be done over again.

#### 6. *Fixation of Unstable Soil on Slopes.*

Owing to the action of water, soil on sloping ground may become unstable. Water filtering downwards causes a reduction in the cohesion of the different layers of the soil, followed by gradual denudation, or landslips. In water-channels the banks may be undermined. The result is a reduction in the productive power of the slopes, while the level ground below may be covered with the débris brought from above; at any rate the water-channels in the low land silt up, and give rise to inundations.

The detailed consideration of this subject belongs to Forest Protection. It will suffice here to state that the best preventive measure consists in keeping such ground permanently under forest growth, from which domestic animals should be excluded.

If a bare area exposed to denudation is to be wooded, it may be necessary to fix the soil before sowing or planting be attempted. This is done by regulating the existing water-courses, terracing them, and even erecting wooden or masonry revetments. Where necessary; additional water channels must be cut to lead off all surplus water into the regular channels. Cattle of all kinds must be strictly excluded. The land itself may have to be terraced, or wattle fences may be erected at suitable intervals. Only after the soil has been

rendered stable can the formation of a wood be commenced.

Works of the above-mentioned kinds have been executed on a large scale in the French,\* Swiss, and Austrian Alps, as well as in the Jura.

\* See "Traité pratique du Reboisement et du Gazonnement des Montagnes." by P. Demontzey. Paris, Rothschild, 13. Rue des Saints-Pères.

## CHAPTER II.

## FORMATION OF WOODS.

THE formation of a wood comprises all silvicultural measures having for their object the production of a new crop of trees. Such a crop can spring up from seed, slips, layers, pieces of roots, or from stool shoots and root suckers. In some cases the formation of a new crop is the result of the spontaneous action of nature, in which case the forester speaks of *natural formation or regeneration*, in others the seed or seedlings are brought on to the land by the action of man, when the process is called *artificial formation*. A further distinction must be made as regards the special kind of material employed for the formation of a wood. Again, two or more methods of formation may be combined. Finally, a wood may be composed of a mixture of two or more species. Accordingly, the matter to be dealt with in this chapter has been arranged under the following sections:—

- I. Artificial formation, or sowing and planting.
- II. Natural regeneration through seed, shoots and suckers.
- III. Choice of method of formation.
- IV. Formation of mixed woods.



## SECTION I.—ARTIFICIAL FORMATION OF WOODS.

## A. Direct Sowing.

Under "direct sowing" is understood the formation of a wood by the sowing of seed directly on the area which it is proposed to stock. This can be done in various ways. Whatever the chosen method may be, its success depends on considerations which hold good, more or less, for all; hence, the general conditions of success must be dealt with, before a description of the different methods of sowing can be given.

## I. CONDITIONS OF SUCCESS.

1. *Choice of Species.*

The considerations which guide the forester in the selection of the species to be grown are given in Chapter I. In this place attention will be drawn to the fact, that under the system of direct sowing, only a moderate amount of protection can be given to the seed in the ground and to the young seedlings which may spring up. Trees with delicate seeds and seedlings are, therefore, less suited to this method than hardy species which thrive easily, and especially those with large seeds.

2. *Quality of Seed.*

It is of paramount importance to use only good seed. The quality of the seed depends principally on its being perfectly ripe and on its weight and size, age and origin.

*a. Weight and Size.*

In the case of one and the same species, large heavy seeds are better than small light ones. The former generally possess a greater germinating power, and the resulting seedlings show a greater power of resistance against external injurious influences, and a more vigorous development, which in many species is due to the greater quantity of reserve materials deposited in the seed. This superiority at the first start should not be under-estimated, because it is recognisable long after the seedling stage has been passed. In many cases the dominant trees grow out of the seedlings which had the best start.

The actual weight of good seed varies according to locality. The following figures are given as examples; they represent averages for clean seeds without wings calculated from the best available data :—

	Number of Seeds per pound.
Sweet Chestnut . . . . .	115
Oak, pedunculate . . . . .	130
Beech . . . . .	2,000
Maple (Sycamore) . . . . .	5,000
Ash . . . . .	6,500
Broad-leaved Lime-tree . . . . .	5,000
Small-leaved „ . . . . .	15,000
Hornbeam . . . . .	14,000
Elm . . . . .	70,000
Alder . . . . .	300,000
Birch . . . . .	800,000
Silver Fir . . . . .	10,000
Weymouth Pine . . . . .	30,000

	Number of Seeds per pound.
Spruce . . . . .	65,000
Scotch Pine . . . . .	70,000
Larch . . . . .	75,000

*b. Age.*

The germinating power of seed is greatest immediately after ripening; it can be maintained for a shorter or longer period according to species and treatment. It follows that, the sooner seed is sown after ripening the better. This becomes absolutely necessary in the case of Elm seed, as it only keeps for a very short time. The seeds of Birch, Alder, Silver Fir, Sweet Chestnut, Beech and Oak may be kept until the following spring, but on no account should seeds of these species be used more than six months old. In the case of Lime, Hornbeam, Maples, Ash, Larch, Spruce and Scotch Pine, seed up to two years old may be used; if older it should be rejected.

When seed is stored it must be kept free from moisture, and protected against heating by keeping it in an airy locality and turning it over from time to time.

*c. Source.*

The source whence seed has been obtained is of importance. Although trees of all ages can yield excellent seed, as a general rule it may be said that, the best seed is derived from trees which are in the prime of life, namely healthy trees with a full crown, which have just completed their principal height-growth. At the same

time, soil and climate, and especially the latter, are of greater importance than the age of the trees.

The question has been raised, whether it may be advantageous from time to time to obtain seed from another locality, as is done in agriculture. This may become desirable when the trees are affected by disease or by peculiarities which are transmitted through seed, as for instance twisted fibre; apart from such cases, it is probably better not to change the seed. Trees live for a long space of time, and they accommodate themselves to a locality, so that home seed is likely to do best.

#### *d. Testing Seeds.*

The quality of seeds can be judged by their external and internal appearance. Good seeds fill up the outer coat, are of a good rich colour, possess a healthy smell, and look fresh in the interior when cut open. The percentage of good seed can, in the case of heavy seeds, such as Oak, Sweet Chestnuts, and Beech nuts, be judged by putting them into water, when those properly developed will sink, while the bad and inferior ones will float on the surface.

When accurate information is required, regular germinating tests must be applied. These consist in subjecting a certain number of seeds, usually 100, to conditions which secure quick germination, namely a steady degree of moisture, a temperature of 60—70 degrees Fahr., and free admission of air. Any arrangement which secures these conditions will do; as instances, the following may be mentioned:—

*The Pot-test.*—Fill a shallow, porous flower-pot with

loose earth, place the seeds on the earth, cover them with some moss, maintain an even temperature, and water periodically, or better still, place the pot inside another containing water. The seeds should be removed as they germinate, keeping an account of them day by day.

*The Flannel-test.*—Place the seeds between two pieces of flannel, or filtering paper, maintain an even temperature, and water steadily, either by a spray or by connecting the flannel with a dish of water.

Of late years a considerable variety of germinating apparatus have been invented, but it is doubtful whether any of them surpasses the more primitive tests described above, especially the flannel and filtering-paper tests.

The percentage of seeds fit to germinate differs much, not only according to species, but also in different samples of seed of the same species. Seed may be considered good if a carefully conducted germinating test gives the following percentage \* of germinable seeds:—

Austrian Pine	}	.	.	75	per cent.
Spruce . . .					
Scotch Pine . .	}	.	.	70	,, ,,
Mountain Pine					
Hornbeam . . .					
Oak . . . . .	}	.	.	65	,, ,,
Ash . . . . .					
Weymouth Pine					
Lime . . . . .	}	.	.	60	,, ,,
Sweet Chestnut					
False Acacia . .	}	.	.	55	,, ,,
Maple . . . . .					

\* According to Gayer.

Silver Fir . . .	}	. . . 50 per cent.
Cembra Pine . . .		
Beech . . .		
Elm . . . . .		45 ,, ,,
Common Alder . . .	}	. . . 35 ,, ,,
Larch . . . . .		
Birch . . . . .		20 ,, ,,

### 3. *Quantity of Seed.*

The density of a forest crop should be sufficient, on the one hand, to give a proper shelter to the soil, and, on the other, to provide for each tree that growing space which is best suited for its proper development. The first object would be obtained by thick sowing, but in that case the development of the trees would be soon interfered with; hence a mean must be struck; in other words the density of the young crop should be such that a fair cover overhead will be established within 5—10 years after sowing. This consideration governs the quantity of seed to be sown per unit of area. The actual quantity depends on the quality of the seed, the nature of the soil, the mode of growth of the species, and the dangers to which the seed and the young seedlings are exposed. Of these the quality of the seed has already been dealt with.

*The Soil.*—Almost any soil can nourish a full crop of seedlings, so that the chemical composition of a soil becomes of importance only after the young crop has closed up and the struggle for existence commenced. Of far greater importance, during germination and the early stage of life, are a proper degree of moisture, heat,

and porosity. A dry, loose, stony soil, and again a hard, cold soil, require more seed than a fresh soil of middling porosity.

*The Mode of Growth.*—In the case of species which are of quick growth during youth, less seed is required than for others which grow slowly at first and do not close up for some time.

*External Dangers.*—The seeds are liable to be eaten by animals. Amongst these, birds are most injurious. To protect small seeds against birds they may be coated with red lead. Mice may be caught in traps or poisoned. The young seedlings are subject to injury by animals, fungi, the effects of climate, such as frost, drought, excess of moisture, and they are liable to be choked by weeds. The quantity of seed to be sown is governed by the extent to which such injuries may be expected to take place in any given locality.

Although it is, therefore, impossible to give the actual quantity of seed required in any particular case, the following figures may be taken as illustrating, under average conditions, the necessary quantities in the case of broadcast sowing, the seed being of good quality and clean :—

	Quantity of Seed in Pounds per Acre.*
Oak . . . . .	550
Beech . . . . .	150
Hornbeam } . . . . .	35
Ash . }	
Maple . }	30
Birch . }	
Elm . . . . .	25

\* The figures represent averages derived from the best available information.

	Quantity of Seed in Pounds per Acre.
Alder . . . . .	15
Silver Fir . . . . .	40
Larch . . . . .	14
Spruce . . . . .	10
Scotch Pine . . . . .	6

In the case of partial sowing, the quantity of seed is proportionately smaller, thus for

Sowing in strips, furrows, or ditches . . . . .	about 65—75% of broadcast sowing.
„ „ patches . . . . .	50 „ „
„ „ pits or holes . . . . .	25—35 „ „

#### 4. *Conditions of Germination.*

The process of germination consists of the following :—

- (1.) Swelling of the seeds ;
- (2.) Chemical change of the nourishing substances deposited in the seed ;
- (3.) Development of the embryo.

The swelling of the seed is due to the absorption of water. If then a sufficient amount of heat and oxygen are available, the reserve materials are changed into soluble substances fit for the formation of new cells ; growth then sets in, which causes an enlargement of the embryo, followed by the bursting of the shell of the seed and the protrusion of the rootlet.

The conditions for the successful germination of forest seeds are thus :—

- (1.) A constant but moderate supply of water ;



- (2.) A temperature not lower than 45°, but better from 55—75° Fahr.
- (3.) Admission of air, whence the oxygen is derived.

The presence or absence of light are of no importance.

These conditions can easily be provided in the case of small experiments, but in operations conducted on a large scale they are only to a certain extent rendered practicable by a suitable condition of the germinating bed, by the manner of covering the seed, and by sowing at the most suitable time of year.

*a. The Germinating Bed.*

A suitable condition of the germinating bed is of prime importance; it is secured by working or loosening the soil, in some instances by draining or irrigating, and in exceptional cases by manuring.

*Loosening the soil* secures the following advantages:—

- (1.) It enables the roots to spread more readily, and to penetrate deeper into the ground, thus rendering the young plant more independent of variations of moisture in the surface soil.

- (2.) It effects a mixture of the different layers of the soil, thus rendering the nourishing substances more readily available and causing greater activity in chemical changes.

- (3.) It freely admits air and heat.

- (4.) It exercises a favourable effect upon the degree of moisture in the soil. Rain-water penetrates more readily and to a greater depth, while subsequently, during dry weather, it rises again by capillary attraction.

As a set-off against these advantages the following drawbacks must be mentioned :—

(1.) On steep slopes loosening the soil may be followed by denudation, as rain-water can more easily carry it away.

(2.) Frost-lifting may occur more frequently.

(3.) It may attract injurious insects, such as the cockchafer, the larvæ of which are very destructive to roots.

The degree of loosening, and the depth to which it may reach, depend on the original condition of the soil. Hard or wet soil requires more ;—naturally loose soil less or no working.

In some cases the actual process of loosening the soil must be preceded by the removal of an obstructive surface covering, such as woody shrubs, weeds, grass, moss, ferns, heather, raw-humus, etc. ; in other cases this is not necessary. The loosening itself can be done in a variety of ways ; by means of tools, such as the plough, harrow, rake, hoe, or spade ; by allowing it to be broken up by swine ; or by a temporary cultivation of field crops. Whether the one or other is preferable depends on the method of sowing and the cost of the operation.

Too much moisture may prevent or retard germination, may obstruct aëration of the soil, or render it cold and cause the seed to rot. These inconveniences can be prevented either by a better distribution of the water, or by draining. The latter plan should be restricted to cases where the moisture is really excessive, and where no injurious effect upon adjoining areas is likely to be produced. In forestry it

is better to drain too little than too much; in many cases the forester will do well to be satisfied with a species which will grow in moist or wet soil, rather than endanger the proper development of valuable species growing on adjoining lands.

Irrigation may become necessary where the soil is excessively dry. It is an expensive operation, and the necessary outlay will only be recouped in special cases.

Manuring hardly ever occurs, except in nurseries, because it is too expensive compared with the increase in the returns which it is likely to secure.

#### *b. Time of Sowing.*

Nature sows in autumn in the case of most species growing in temperate Europe, in some cases in summer, and in others in winter or spring; hence no absolute guide is given as to the best time for sowing. Of the naturally sown seed a large portion, while lying over winter, is eaten by animals, or perishes through adverse influences of the weather, so that only a small portion actually germinates in spring. In artificial sowings the seed must be carefully husbanded, hence it should be done at the most favourable season for germination, namely when the soil is sufficiently moist and when sufficient heat is available. The best time for sowing in temperate Europe is during April and May, according to the local climate.

The above rule is subject to exceptions, because some seeds will keep in good condition only for a very short period, or their preservation involves much trouble

and expense. The seed of the Elm ripens, on an average, at the end of May or in the early part of June, and loses its germinating power very rapidly; hence it should be sown at once. The seed of Silver Fir ripens in autumn, and as it does not keep well, it should be sown at once, and not kept till spring. Many foresters prefer sowing heavy seeds, like those of Oak, Beech and Sweet Chestnut, in autumn, because they are bulky and it is expensive to keep them in good condition over winter. At the same time these heavy seeds are much exposed to attacks by animals during winter, and as autumnal sowings germinate early in spring the seedlings are exposed to late frosts; hence sowing them in autumn is of doubtful expediency.

In some cases autumn sowings are indicated in localities which are not accessible until late in spring, such as high altitudes where snow does not disappear before June. Again, Alder seed is frequently sown in winter, immediately after harvesting, as it is difficult to keep until spring.

To sum up, it may be said that in temperate Europe spring sowing should be the rule, but that certain species and certain local conditions demand exceptional treatment.

In other parts of the world, under different climatic conditions, the best time for sowing also varies according to circumstances. In the Indian plains and low hills the general rule is to sow at the commencement of the summer rains, because the seeds will then be assured of a sufficient supply of moisture, and the seedlings will have time to establish themselves thoroughly in the ground, before the next dry season comes round. Sow-

ings on irrigated lands can be made at other seasons. The seed of some Indian species does not keep, and indeed the seed of Sal (*Shorea robusta*) often germinates before it falls, and must therefore be sown as soon as it ripens. In those regions of the Himalayas, where snow may lie until late in the spring, both autumn and spring sowings are made, there being perhaps no decided balance in favour of the one or the other season.

*c. Covering the Seed.*

The objects of covering the seed are chiefly the following:—

- (1.) To protect it against sudden changes of moisture and temperature.
- (2.) To protect it against being eaten by animals, especially birds, or being carried away by wind or water.

In natural woods large quantities of seed fall to the ground; some of it is carried by rain-water through the vegetable covering down to the mineral soil, thus finding conditions favourable for germination. In artificial sowings the necessary protection is afforded by covering it with earth to a certain depth.

The thickness of the covering is of considerable importance; if too thin, the seed is exposed to attacks by animals, is liable to dry up or to be injured by frost; if too thick, germination is retarded, the seedlings have great difficulty in pushing through the covering, and germination may altogether fail for want of sufficient air. The actual thickness depends on the general condition of the seed-bed and the species. It must be

thicker in the case of loose or dry soil, and thinner in firm or wet soil.

The seed of different species requires a different covering. On the whole, large seeds such as acorns and chestnuts, require the thickest covering; considerably less, the seeds of Beech, Maple, Hornbeam, Silver Fir; less again, those of Alder, Ash, Scotch Pine, Spruce, and Larch; least, those of Elm and Birch.

According to experiments made by Baur\* on loamy sand the best results were obtained with coverings of the following thickness:—

English Oak . . . . .	1·50 inches.
Beech . . . . .	·75 „
Sycamore and Silver Fir . . . . .	·60 „
Scotch Pine and Spruce . . . . .	·50 „
Common Alder . . . . .	·40 „
Larch . . . . .	·35 „
Elm . . . . .	·12 „

The seed can be covered in various ways, by ploughing (in the case of acorns), harrowing, raking, light hoeing, or by scattering fine earth over it.

#### *d. Sprouting of the Seed.*

During germination the rootlet is first developed, and then the stem; as soon as the latter breaks through the surface of the soil, the seed is said to sprout. A few European species, such as Oak, Sweet Chestnut and Hazel, leave their cotyledons below the surface, but the majority bring them above ground.

\* Professor of Forestry at the University of Munich.

The interval of time between the sowing and sprouting depends on the species, the age of the seed, and the conditions of germination.

*Species.*—Good seed sown in spring, under average conditions, may be expected to sprout after a lapse of time ranging from a week up to two and even three years. The following data may be taken as illustrations:—

Poplars and Willows . . . . .	after about 10 days.
Elm . . . . .	„ „ 10—20 days.
Birch . . . . .	„ „ 2—3 weeks.
Scotch Pine, Black Pine,	
Weymouth Pine, and Larch „ „	3—4 „
Spruce, Silver Fir . . . . .	„ „ 3—5 „
Oak, Beech, Maple, and Alder „ „	4—6 „

Ash, Lime, Hornbeam, and Cembran Pine generally after one year, Yew after one and often two and even three years.

*Age of Seed.*—Fresh seed germinates always quicker than old, the latter sometimes not until the second year.

The time of sprouting depends much on the conditions to which the seed is subject; a heavy covering retards germination; warm soil and sufficient moisture produce quicker sprouting than cold soil or drought.

Seeds are sometimes specially treated with the object of accelerating the sprouting. Amongst the various methods which have been recommended, the following may be mentioned:—soaking in water, ranging from an hour to a week; treatment with lime water or highly diluted hydrochloric acid; steaming; soaking in liquid manure. Apart from the first mentioned, great care

is required in applying the various treatments, else the seeds may be injured. In the case of large seeds, like those of Teak, collecting them in a heap and keeping them continuously moist may considerably accelerate germination. Seeds which germinate only in the second year may be bedded in sand in a ditch or pit, and only sown in the second spring.

## II. METHODS OF SOWING.

In the course of time a great variety of methods of sowing have been elaborated. It would be beyond the scope of this book to describe them all in detail; moreover they can only be fully understood by studying them in the field. Hence only the more important modifications will here be mentioned. Sowings may be divided into:—

1. Broadcast sowing.
2. Partial sowing.

### 1. *Broadcast Sowing.*

If the seed is distributed evenly over the whole area to be stocked, the method is called broadcast sowing.

#### *a. Preparation of the Soil.*

In some cases broadcast sowings are made without previous or subsequent cultivation, but they are liable to lead to disappointment unless executed under specially favourable circumstances. The soil must be naturally free and capable of retaining moisture near the surface; the seed must germinate readily and be sown in large quantities; the locality must be free from climatic



extremes, and the surface of the ground not very steep, or the seed may be washed away; the seedlings must be hardy. Such a combination of conditions is only exceptionally met with.

As a general rule the soil requires some cultivation before the seed is sown. This can sometimes be at once undertaken; in other cases it must be preceded by the removal of an objectionable covering.

*Removal of Surface Covering.*—This may consist of shrubs, weeds, reeds, or excessive layers of moss and leaf-mould. It may be removed, according to circumstances, with billhooks, knives, scythes, rakes, hoes, or by hand. The refuse may be used for litter or other purposes, or it may be burned when dry, the ashes being scattered over the area. If the covering is sufficiently dry, the area may be burned over without previously collecting the material, care being taken that the fire does not spread into adjoining woods.

In the case of a short weed-growth, or moderate layer of moss or raw humus, it need not be previously removed, but may be dealt with simultaneously with the loosening of the soil.

*Cultivation, or Loosening the Soil.*—This can be done in a variety of ways, according to the required depth of cultivation. The tools used are principally the following:—

For superficial loosening or so-called <i>wounding</i> of the soil . . . . .	} The rake, harrow, or a light hoe.
--	--

For moderately deep cultivation . . . . .	} The hoe.
---	------------

For deep cultivation . . . . .	The plough and spade.
--------------------------------	-----------------------

*Superficial loosening or wounding the soil* is indicated on localities which are already of a fairly loose consistency, and covered with a moderate amount of turf, moss or leaves.

*Hoe cultivation* is in its place when the soil is somewhat heavier, uneven, stony, or where the roots of a previous crop of trees are still in the ground.

The use of the *plough* is restricted to fairly level areas, comparatively free from stones, stumps, or big roots. Attempts have been made to introduce ploughs of specially strong structure for the cultivation of stony soils or for breaking up soil containing roots, but their application is so limited that they need not here be further considered.

*Spades* are the best of all instruments for cultivation, but work performed with them is too expensive for ordinary forest operations; hence their use is generally restricted to nurseries, for trenching areas with an impermeable substratum, or for planting.

In the case of light and middling soils the loosening may be done immediately before the sowing of the seed. Heavy soils, or those containing considerable quantities of raw humus, heather, broken up impermeable layers, woody weeds, etc., should be worked in autumn and remain unsown over winter, so as to be subjected for some time to the action of air, rain and frost. Such soils may require a second more superficial working in spring before the seed is sown.

Many and various are the forms of the several tools which have from time to time been recommended for use in the preparation of the soil. Of these, a considerable number are of doubtful utility. As a general rule

the ordinary labourer gets through more and better work by using the tools with which he is acquainted, than by substituting even an improved form of tool, the use of which he has first to learn. Moreover he will take greater care of his own tools than of those provided for him.

Under these circumstances the introduction of novel tools can only be recommended, when their use really secures a considerable saving of labour.

Some of the better forms of the principal tools here in question are represented on page 60. The following few remarks will explain their use:—

Fig. 18 represents a scythe with a short strong blade, used for cutting heather, broom, &c.

„ 19, a hoe used for the removal of ordinary weeds, grass, &c.

„ 20, a three-pronged hoe, used for wounding the soil.

„ 21, a narrow light hoe, used for superficial hoeing in light soils.

„ 22, a broad hoe, used for clod hoeing.

„ 23, a light hoe with a hatchet on the reverse (or a miniature mattock), used for hoeing in soil which contains roots from a former crop.

„ 24, a two-pronged hoe, used for light hoeing or wounding the soil.

„ 25, a simple pick, used in working stony or gravelly soil.

„ 26, a strong hoe, used on soils with roots, or on stony ground.

„ 27, a pickaxe, being a combination of figs. 25 and 26.



Fig. 18.



Fig. 19.



Fig. 20.



Fig. 21.

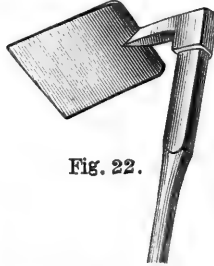

Fig. 22.



Fig. 23.



Fig. 24.



Fig. 25.



Fig. 26.



Fig. 27.



Fig. 28.

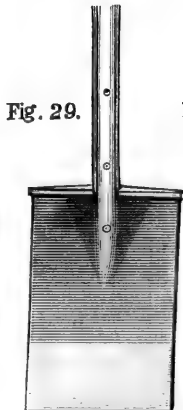

Fig. 29.

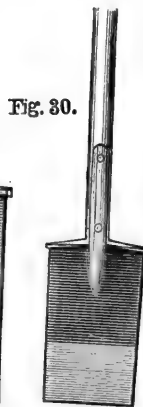

Fig. 30.



Fig. 31.

Note.—Figures 18 to 23 and 25 to 27 are taken from Heyer's Waldbau, Figure 24 from Gayer's Waldbau, and Figures 28 to 31 from Messrs. Thos. Black & Sons' catalogue (Berwick-on-Tweed).

Fig. 28, an Irish spade.

„ 29, a Scotch planting spade.

„ 30, a light planting spade.

„ 31, a four-pronged digging fork.

*b. Sowing.*

Seed may be sown by hand or by machines. The latter can only be used on fairly level ground, with a loose soil free from stones and roots; they frequently cover the seed at the same time. In the majority of cases the sowing will have to be done by hand. The essential point is to distribute the seed as evenly as possible; hence it is desirable to divide large areas into smaller sections, and to allot a proportionate quantity of seed to each. The sowing of small seeds is done as in the case of ordinary grain sowing. A good plan, in the case of level ground, is to sow cross-wise; that is to say, to divide the seed into two parts, to sow one half in one direction, and the other half cross-wise over it. This plan can, however, not be adopted on steep ground. Light seed should not be sown during windy weather, else it will be unevenly distributed.

Where seeds of two species are to be sown, they should be thoroughly mixed before sowing; if they differ in size or weight, it is best to sow them separately, or one cross-wise over the other.

Heavy seed may be placed in plough furrows, or singly brought into the ground.

*c. Covering the Seed.*

The method of covering the seed depends on the mode of working the soil and the size of the seed. In the

case of shallow working and light seeds, the harrow and rake are the most useful tools to use; in some cases it may suffice to drive a flock of sheep over the area, which will press the seed into the soil by trampling on it. Where heavy seeds are to be covered on level ground, the operation may be done by ploughing, or with the rake or hoe.

*d. General Remarks.*

Broadcast sowing is generally very expensive, owing to the cultivation of the soil and because it requires a large quantity of seed; hence it should be restricted to localities which require little or no cultivation, or where a raw soil and a strong growth of shrubs and weed necessitate a thorough cultivation, before success can be expected. In some cases the operation may be combined with the raising of one or more field crops, thus recouping the cost of cultivation.

*2. Partial Sowing.*

With a view of reducing the cost of cultivation and the quantity of seed, the sowing may be restricted to a portion of the area to be stocked. The method may become necessary in the case of localities which contain rocks, stumps of trees, or which are too wet for full working and sowing. In either case it is desirable that the portions to be sown should be distributed as evenly as possible over the whole area; they can be arranged in a variety of ways, of which the following may be mentioned:—

- a.* Sowing in strips and furrows.
- b.* „ „ patches.

- c. Sowing in holes.
- d. ,, ,, trenches, or pits.
- e. ,, on ridges, or mounds.
- f. Combinations of two or more methods.

a. *Sowing in Strips and Furrows.*

The seed bed generally consists of uninterrupted strips, which alternate with unsown strips or bands (Fig. 32). Where rocks or other obstacles are met with, the strips

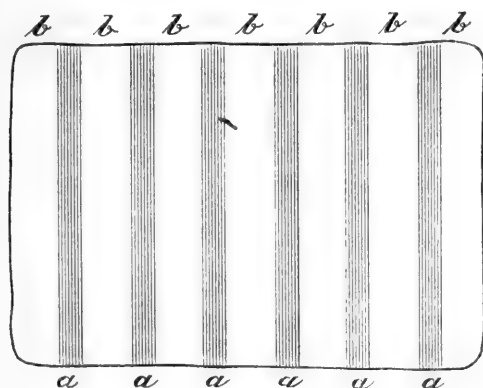

Fig. 32.

a, a. Sown strips.

b, b. Unsown areas.

will be interrupted; the same may occur on sloping or uneven ground. The strips should, as far as practicable, run parallel to each other. On sloping ground they should run in a horizontal direction, and be level, or nearly so, to prevent denudation. On very steep slopes the seed-beds should form terraces.

The width of the sown strips depends principally on the degree to which the unsown strips are likely to be overrun by weeds, brambles, etc., and on the rate of height-growth of the species during early youth; the

greater the former, and the slower the latter, the broader should be the sown strips. Generally the width would range between 18 inches and 3 feet.

The distance between the strips depends on similar considerations. In addition, the desired density of the wood has to be considered. The distance would ordinarily range from 3 to 6 feet. .

The cultivation of the soil is generally done with the hoe or plough; the sowing is best done by hand, a method which various machines have not yet succeeded in superseding. The seed should be covered up with rakes or harrows, and in the case of heavy seeds sometimes with the plough.

Apart from a reduction of expenditure, strip sowing has other advantages over broadcast sowing; the soil can, without incurring an excessive expenditure, be more carefully prepared and the seedlings more effectually protected.

When each strip consists of one, or perhaps two furrows, drawn with a plough, the method is called *sowing in furrows*; it is specially employed in sowing heavy seeds, the seed being sown in the furrow and covered, either by drawing a second furrow, or with the rake or hoe. It admits of a further reduction of expenditure as compared with regular strips.

#### *b. Sowing in Patches.*

The seed-beds consist of round, oblong, square or rectangular patches of limited extent, scattered as evenly as practicable over the area. The extent of each patch varies according to circumstances; they may be of any



size, but are mostly from 1 to 3 feet square, or they assume the shape of interrupted strips, which are from 1 to 2 feet broad and perhaps from 3 to 10 feet long. The distance between the patches depends on the same considerations as in the case of strip-sowing.

The method is cheaper than the regular strip-sowing; it enables the forester, on uneven or rocky soil, to select the most suitable spots for the seed-beds, a matter of greater moment than a mathematically even distribution of the patches.

The working of the soil is best done with the hoe; on stony soil hoes with narrow and very strong blades are used, or even the pick may be required. The seed is covered with the rake or by hand, or by scattering earth over it.

The method is well adapted for rocky soils, and localities which still contain the stumps and roots of a former crop of trees. It is less to be recommended for

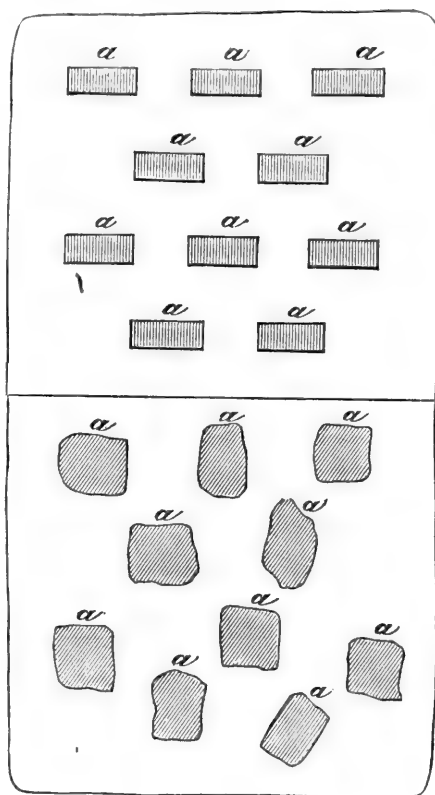

Fig. 33.

*a, a.* Sown patches.

wet soil, as the water is likely to collect on the seed-beds; this would, on the other hand, be an advantage in localities with a scanty rainfall. Where a strong growth of tall weeds is apprehended, the patches must be of sufficient size to prevent the plants from being overgrown.

*c. Sowing in Holes, or Dibbling.*

Sowing in holes means sowing in patches of such limited extent that only a few seeds are sown in each. The soil may be worked with an ordinary hoe of small size, with a spade or with specially constructed modifications of the latter, such as the *spiral spade* (Fig. 34). On stony soil the pick may be used. The spiral spade is forced into the ground and then turned round, so that a seed-hole filled with loose soil is produced. The seed is either pressed into the soil to the required depth, or placed on the surface and covered by hand with a sufficient quantity of fine earth, which is gently pressed down.



Fig. 34.

If the seed-bed is still smaller and consists simply of a narrow hole sufficient to take one or two seeds, which are sown without any preparation of the soil, the method is called "*dibbling*." The minute holes are made with a peg, dibbling mallet, dibbling spade, or any other suitable tool. The instrument is inserted into the ground to the required depth, withdrawn, the seed placed in the opening thus produced, and the latter closed again either

by one or more blows with the instrument, or by pressure with the foot. In some cases the operation may be done without any instrument at all, by removing a small quantity of the surface soil with the foot, inserting the seed, replacing the previously removed earth and pressing it down.

The method is only admissible on soils which are not subject to a heavy growth of weeds, which would probably smother the young seedlings; moderately sized stones or gravel do not interfere with the application of the method.

*d. Sowing in Trenches, or Pits.*

In the methods so far described the seed-bed is, generally, on the same level as the surrounding ground. In the case of trench and pit sowing it is placed below the general surface of the ground, at the bottom of a trench or pit, in which water may collect. The general arrangement of the trenches or pits is the same as in the case of strips or patches respectively. Trenches must be level, to prevent their becoming water-channels. For the same reason they should be here and there interrupted.

The width of the trenches will, as a rule, not exceed two feet at the bottom; the depth depends on the requisite amount of water. The distance between the ditches or pits depends on the same considerations as in strip and patch sowings.

The trenches may be made with the spade, hoe or pick, or partly with the plough and the rest with those tools. The surface soil is kept apart and placed at

the bottom of the trench to serve as a seed-bed, or better still, it is at once placed into the previously made trench.

The seed is sown by hand and covered either by hand or with a rake. Where the trenches can be filled artificially with water, or irrigated, the seed is frequently sown on the upper edge of the ditch (Fig. 35), so that it receives sufficient moisture by percolation, without being destroyed by an excess of water. Where

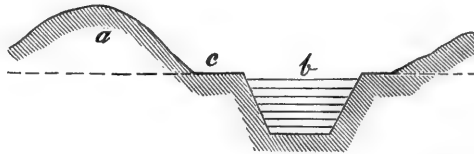

Fig. 35.

*a.* Soil taken out of the trench.

*b.* Trench filled with water.

*c.* Seed-bed.

irrigation water is not available, and the rainfall variable, seed may be sown, both at the bottom of the ditch and along one of the upper edges. In the case of a scanty rainfall the former will succeed, and in case of a wet year, the latter.

The method is indicated in dry hot localities, and where irrigation is practicable. As it is expensive, it should only be adopted in cases where a cheaper method is not likely to yield satisfactory results. The pit method is cheaper than trench-sowing, but it frequently yields less favourable results and is not applicable where irrigation is contemplated.

*e. Sowing on Ridges and Mounds.*

This method is the reverse of the one described under *d.* It is advisable in the case of wet or heavy soil, the object being to raise the seed-bed above the water-level, and to expose the soil to a more complete action of the air. Mounds are interrupted ridges, just as patches are interrupted strips. The ridges or mounds are formed, either by drawing together the surface soil, or better by excavations. In the case of ridges, the ditches run along either one or both sides; in the case of mounds the earth may be taken from an excavation on one side, or from a trench surrounding the mound.

Where a moderate elevation suffices, parallel ditches may be dug and the excavated earth spread evenly over the intermediate spaces, thus forming elevated platforms, on which the seed is sown. See Fig. 15, on page 30.

The seed should be sown densely and not too early in spring, so as to allow a portion of the moisture to evaporate before sowing. The tools used are the same as for trench or pit sowings.

The method is expensive, and only indicated in exceptionally unfavourable localities.

*f. Combinations.*

It happens not unfrequently, that two or more of the different methods are combined in the same locality. Such combinations are indicated when the character of the locality changes from place to place; if, for instance, dry spots alternate with swampy ground, the former may be sown on the natural level or in ditches,

while the latter necessitates sowing on ridges. Where free soil alternates with stony or rocky parts, the former may be sown in strips, and the latter in patches or holes, &c.

### B. Planting.

Under the term *planting* in Sylviculture is understood the method of forming a wood by means of plants which have been raised elsewhere. The success of the operation depends, as in direct sowing, on many matters, which hold good, more or less, for the different ways in which the actual planting is carried out. The business of raising the plants is in itself one of great importance. Planting with slips, layers, &c., again, is so different in many ways from the planting of seedlings, that it had better be considered separately. Hence the subject now under consideration may be divided into the following four parts :—

- I. General conditions of success.
- II. Raising plants.
- III. Methods of planting.
- IV. Planting with slips, layers, &c.

#### I. CONDITIONS OF SUCCESS.

This subject may be dealt with under the following headings :—

1. Choice of species.
2. Different kinds of plants.
3. Quality of plants.
4. Age and size.

5. Season for planting.
6. Density of planting.
7. Distribution of plants over area.
8. Number of plants per unit of area.
9. Lifting plants.
10. Pruning.
11. Protection in transit.
12. Preparation of the soil.

### 1. *Choice of Species.*

Reference is invited to what has been said in Chapter I., Section I. of this volume. In addition, it remains to be mentioned, that planting is admissible in the case of all species, and that it is specially adapted for those which are tender during early youth, and which cannot receive sufficient attention and protection in direct sowings on a large scale ; also to species, the seed of which is expensive, or exposed to dangers from animals.

### 2. *Different Kinds of Plants.*

The plants used in Sylviculture are of many kinds, according to external form, origin, age, &c. No general classification is possible, since the various groups overlap each other. For practical purposes the following divisions will prove useful :—

A distinction must, in the first place, be made between plants which have sprung directly from seed, and those which formed part of an already existing individual ; hence the division into :—

- (1.) Seedling plants,
- (2.) Suckers, layers, or cuttings.

All woody plants can be successfully raised from seed, but only certain species from suckers, layers, or cuttings.

*Rooted plants* are distinguished from plants *without roots*. Seedlings, suckers, root cuttings, and layers when they have become independent individuals, are rooted; cuttings taken from the stem or branches are without roots at starting, but they may become rooted by placing them in a nursery before putting them out into the forest.

*Complete or incomplete plants*; the former have their roots, stem and branches entire, while in the case of the latter, parts of the plants may have been pruned away.

*Seedlings or transplants*. — The former are plants which are transferred direct from the seed-bed to the forest; the latter, those which were previously pricked out, once or several times, in the nursery.

*Plants with or without balls*, or lumps of earth in which the roots are imbedded.

Plants may be classified, according to *size*, as small, middle sized, and large plants, but the limits of each class differ according to the kind of plant, as well as to locality and custom.

### 3. *Quality of Plants.*

The success of planting operations is governed by the quality of the plants which are used, just as the success of direct sowings depends on the quality of the seed. Hence, only healthy vigorous plants should be used, which are likely to bear well the interruption of growth involved in the transfer from one locality to another,



under circumstances admitting only of a limited amount of attention being paid to each plant.

The vigour, or growing power, of a plant is indicated by a normal shape and a healthy appearance. The development of each part must be in due proportion to the rest; the plant should be neither tall and thin, nor too short and stout; nor should the stem be crooked, especially in the case of coniferous plants; the root system should be ample, with a fully developed system of rootlets; the crown should have a healthy green appearance, and possess numerous well-developed buds.

These are the general characteristics of good healthy plants. At the same time they are subject to some modifications as regards species, age, and the locality which it is proposed to plant up. More especially some caution is necessary in transferring plants from a rich to a poor soil; from a cool northern aspect to a hot southern one; from a low to a high situation; from a sheltered to an open spot, etc.; in other words, what is a good plant for one locality, may be only an indifferent one for a locality of a different character.

A further modification may be introduced respecting the cost of raising the plants and of planting them out. Plants with naturally extensive root systems, either cost much to plant out, or the roots must be crowded together in an unnatural position; from this point of view a compact root system may be considered as an essential point in a good plant, though it may not be altogether in proportion to the stem and crown.

#### 4. *Age and Size of Plants.*

Plants aged from a few weeks up to ten and more years may be planted out; in fact the age is only limited by the size and weight of the trees, and the mechanical appliances available for the transfer. In Sylviculture only young plants under ten years of age need be considered. It may be said, as a general rule, that young plants are best, because the operation of planting is cheaper; the plants survive more easily the interruption of growth involved in the change, and they adapt themselves more readily to new conditions. The best age for planting out depends on the species and locality. Quick-growing species can be planted out earlier than slow-growing ones. Some tropical species grow so quickly that the most suitable age for transplanting amounts to only a few weeks. In the temperate climate of Europe yearlings are only exceptionally planted out, as they are still too soft and have incomplete root systems. In the great majority of cases plants from two to four years old are used, while older plants are indicated only in the case of a few species, or where trees of some height are required, as in pastures; in frost localities; for filling up blanks in already formed plantations; to become the underwood in coppice with standards; to enable one species to hold its own against another of quicker growth; for avenues; &c.

#### 5. *Season for Planting.*

The planting out is, after all, a violent operation, and is generally accompanied by more or less injury to the

root system, with a temporary interruption of the growth. These disadvantages can, by special care, be reduced to a minimum, so that they affect the further development of the plant only to a small extent. As long as the root system is completely imbedded in a ball of earth, transplanting can be done at any time of the year, provided the soil is in a fit condition (neither frozen, nor too wet or dry). Again, plants, the roots of which are not imbedded in a ball of earth, can similarly be transplanted with success, provided the operation is performed with care; but as this involves extra expense, it is difficult to ensure in the case of large operations; hence the most favourable season should always be chosen for sylvicultural planting.

The most favourable season differs according to the character of the locality. In temperate Europe, summer should be avoided, because at that time the plant is in full assimilating activity, and most sensitive to a change of conditions, especially to drought. There remains then the period from autumn to spring. Planting may be done at any time throughout that period, provided the weather be sufficiently favourable; at the same time mid-winter is generally the least favourable part of this period, as frost may be expected, so that practically the choice lies between autumn and spring. Each of these two seasons has its advantages and drawbacks, and the question whether the one or other is more favourable has been much debated.

In the case of autumn-planting any rootlets which have been injured during the operation may be replaced by the ensuing spring, and the loosened earth settles down again during winter. On the other hand, the plants are likely to suffer from severe frost in their new

home, or they may be lifted by alternate frost and thaw. Autumn-planting is preferable in the case of localities which are not accessible until late in spring, or of species which start early in spring.

Spring-planting has the advantages that labour is more readily obtainable, and the period of severe frost is past. On the whole it is preferable to autumn-planting, provided the work can be completed before vegetation begins. In many cases, especially when the operations are conducted on a large scale, both spring and autumn-planting have to be done.

Over the greater part of India the most favourable season of the year is the commencement of the summer rains; the plants receive sufficient moisture, and they have the whole growing season before them to settle down in their new home and to get strong before the next dry season comes round. Land which can be irrigated may be planted at any season, provided the soil is not frozen.

#### 6. *Density of Planting.*

The general principles which govern the density of direct sowing apply also here; that is to say the cover overhead should be established within a period of from 5 to 10 years. As plants come on more regularly than seedlings grown on the spot, planting may be done more sparingly than sowing. For the rest the planting distance depends on:—

- (a.) The locality, in so far as it influences the percentage of failures and the vigour of the plants.
- (b.) The species, especially its degree of hardiness and rate of height-growth in early youth.

- (c.) The age and size of the plants ; young and small plants must be planted closer than old and large ones.
- (d.) The objects of the plantation, whether timber or firewood is to be produced ; whether pieces of large diameter or long boles are the objects of management ; whether the wood is to serve as a protection against landslips, erosion, avalanches, hot or cold winds, &c.
- (e.) The state of the market ; where small produce is saleable at remunerative rates, dense planting is indicated ; under the opposite conditions, wider planting is more profitable.

#### 7. *Distribution of Plants over Area.*

The distribution of the plants over the area to be stocked can be either irregular or regular. The former is done by eye measure, that is to say, after the average distance between the plants has been fixed, the planting spots are selected by eye. This system requires practice.

Regular distribution is done according to geometrical figures, the more usual of which are the following :—

- (1.) The equilateral triangle, where the planting spots are at the three corners of the triangle (Fig. 36).
- (2.) The square, four plants being placed at the four corners of the square (Fig. 37).
- (3.) Equidistant lines or rows, in which case the plants stand at shorter intervals in the lines than the distance between the lines ; the plants may be said to occupy the corners of rectangles (Fig. 38).

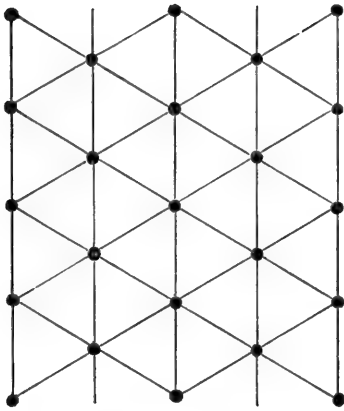

Fig. 36.

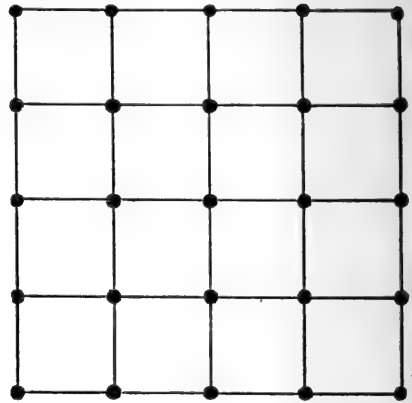

Fig. 37.

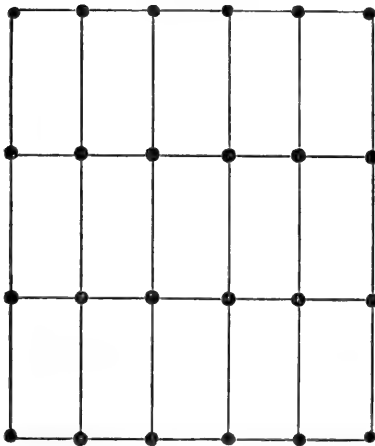

Fig. 38.

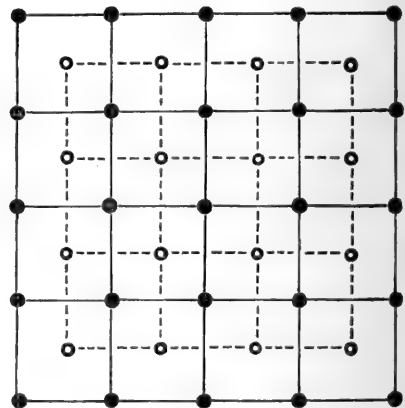

Fig. 39.

(4.) The quincunx form, a modification of the square form, as will be seen on reference to Fig. 39.

A regular distribution of the plants has the following advantages over an irregular one:—

- (i.) An equal growing space is allotted to each plant.
- (ii.) The plants are subsequently easier to find, and protected against being overgrown; failures are easier ascertained.
- (iii.) The area between the plants can be more fully utilized; grass cutting can be allowed at an earlier stage; field crops may be grown between the lines; cattle grazing, where unavoidable, causes less damage, especially if the plants are arranged in lines.
- (iv.) In mixed woods the several species can be more evenly mixed.
- v.) Early thinnings are considerably facilitated.
- (vi.) The woods can be more easily protected against damage, especially by injurious insects, or fire.
- (vii.) It is claimed that regular plantings are cheaper to execute, because the work of distributing and putting in the plants proceeds in a more systematic manner. Whether this advantage is realized or not, depends on the skill of the labourers available and the supervision exercised over the operations.

Against these advantages it must be mentioned that air currents have more easy access to regular plantations, may sweep away the fallen leaves or heap them together, and dry up the soil more rapidly. This disadvantage can be met by planting dense shelter belts against the prevailing wind, or, to some extent, by arranging the planting lines at right angles to the wind direction.

A completely regular distribution is not practicable where the nature of the soil changes rapidly; for

instance, where wet swampy spots alternate with dry parts, or where rocks are scattered over the area; nor is it necessary on small blanks scattered over already existing woods.

The comparative merits of the three principal forms of regular distribution have been much discussed. The triangular form allots to each plant the most regular growing space, since every plant is equi-distant from its neighbours; this favours an even development of the trees. It admits of a greater number of plants per acre, and produces the greatest quantity of material; the saplings also clear themselves more readily of their lower branches. On the other hand, it is more troublesome to lay out, and more expensive than the two other forms.

Line planting has the disadvantage that the cover overhead is somewhat later established, that the saplings develop stronger branches on two sides than in the direction of the lines, which may be accompanied by an eccentric shape of the stem. On the other hand, it admits of the most complete utilization of the ground between the lines, and facilitates thinnings and the removal of the material.

On the whole, these advantages and disadvantages are not of much importance, because after the early thinnings the three forms stand practically on the same footing. Many foresters prefer line planting to the two other forms, because it is easiest to carry out, and perhaps the cheapest. Others prefer the square form; while the triangular form is perhaps less frequently chosen.

The marking of the planting spots is done with two lines (or chains), the so-called *directing line* and the *plant-*



*ing line.* The latter is divided according to the planting distance, each division point being marked in a suitable way, either by a knot, or by drawing a coloured tape through it. On the directing line the distance between successive rows is marked in a similar manner. In the case of square planting the marking is the same on both lines, but different in triangle and line planting. In the latter each division of the directing line is equal to the distance between the rows; in triangle planting, equal to the planting distance multiplied by  $\cdot 866$ .

The lines are of a suitable length, with a pin (or peg) at each end; they should be made of hemp and well tarred, to protect them against moisture. On wet soil a thin chain is preferable to a line, as the latter is liable to alter its length.

When a large area is to be planted, it is desirable to subdivide it, in the first place, into squares or rectangles, the sides of which correspond with the lengths of the planting and directing lines (Fig. 40). After the corners of the squares or rectangles have been fixed, each plot is treated separately; the directing line is stretched along two opposite sides of it (say  $ad$  and  $bc$ ), and the directing spots marked either by the insertion of a small peg, or by a small hole or two directing lines may be used and left on opposite sides, until the square, or rectangle, has been planted; then the planting line is first stretched along  $ab$ , and successively parallel to it until  $dc$  is reached, planting being done as indicated by the marks on the planting line.

It remains to note that, in the case of triangle planting the planting line must be doubly divided, as the plants in every two adjoining rows are shifted by half the

planting distance ; or the planting line must be drawn back by half the planting distance in every alternate row.

The following semi-regular system of planting is much followed in Great Britain :—The planters are arranged in line at stated intervals along one edge of the area (Fig. 41). Each puts in a plant where he stands. The most reliable planter is placed on one flank, and he now advances a space equal to the fixed planting distance in the direction of a previously erected mark (flag), puts

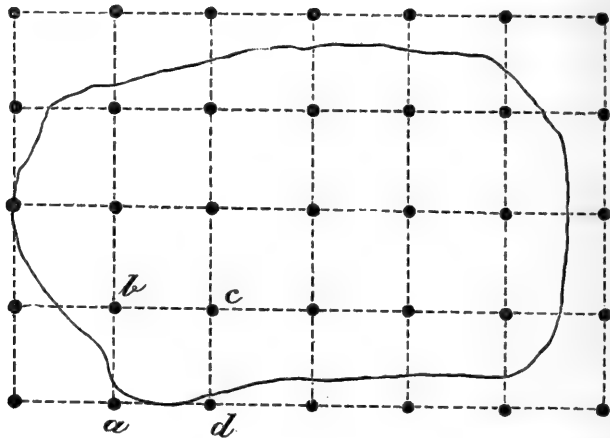

Fig. 40.

in a second plant, advances again the planting distance, puts in a third plant, and so on, until he reaches the opposite edge of the area. As soon as the flanking man has advanced twice the planting distance, the next planter advances one planting distance, keeping at the original distance from the first man's line, and puts in a plant. When the flanking man proceeds to his fourth planting spot, his neighbour proceeds to his third, while the third man advances ; and so on, until

the whole column is in motion, forming a slanting line, each man taking his direction from his neighbour, who is always one planting distance ahead of him. When

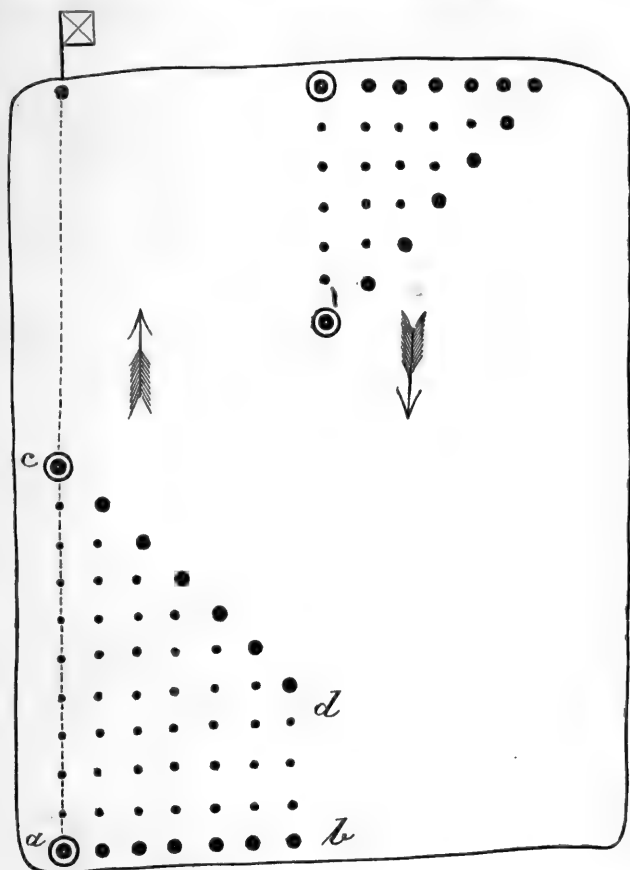

Fig. 41.

*a, b.* Original position of planters. *c, d.* Position when the whole column is in motion.  $\odot$  Flanking man, who gives the direction.

the last man has reached the opposite end of the area, the whole column wheels round and works back again, the flanking man taking his direction from the last row of plants.

The method is exceedingly simple, and yields a degree of regularity sufficient for most purposes, provided the men are well trained to the work.

### 8. *Number of Plants.*

In the case of irregular planting the number of plants required per acre can be roughly ascertained by dividing with the square of the average planting distance, given in feet, into 43560, the number of square feet in an acre.

For regular plantations the following calculations apply:—

*Line planting*:—

Length of area	. . . . .	=	L
Breadth	,, . . . . .	=	B
Distance between the rows	. . . . .	=	$d$
,, ,, plants in the rows		=	$d'$ ;

$$\text{then the number of rows} = \frac{L}{d} + 1,$$

$$\text{and the number of plants in each row} = \frac{B}{d'} + 1,$$

hence the total number of plants:—

$$N = \left(\frac{L}{d} + 1\right) \times \left(\frac{B}{d'} + 1\right) = \frac{L \times B}{d \times d'} + \frac{L}{d} + \frac{B}{d'} + 1.$$

*Square planting*.—Here  $d = d'$  and

$$N = \frac{L \times B}{d^2} + \frac{L + B}{d} + 1.$$

*Triangle planting*.—Here the distance between the rows is represented by the height of the equilateral triangle, which is equal to  $d \times \sin 60^\circ = d \times .866$ ;

hence number of rows =  $\frac{L}{d \times .866} + 1$ , and number of plants in each row, either alternately =  $\frac{B}{d} + 1$  and  $\frac{B}{d}$ ; or always  $\frac{B}{d}$  according as to whether  $\frac{B}{d}$  is a whole number, or  $\frac{1}{2}$  more.

In the one case

$$N = \frac{1}{2} \left( \frac{B}{d} + 1 \right) \left( \frac{L}{d \times .866} + 1 \right) + \frac{1}{2} \frac{B}{d} \left( \frac{L}{d \times .866} + 1 \right)$$

$$N = \frac{L \times B}{d^2 \times .866} + \frac{B}{d} + \frac{L}{2d \times .866} + \frac{1}{2}.$$

In the other case

$$N' = \frac{B}{d} \left( \frac{L}{d \times .866} + 1 \right)$$

$$N' = \frac{L \times B}{d^2 \times .866} + \frac{B}{d}.$$

The first term in this and the two previous formulas represents the bulk of the plants. By neglecting the comparatively small number represented by the other terms, the following short approximately correct methods of calculation are obtained for each acre of plantation:—

*Square planting*—

$$N = \frac{43560}{\text{Square of planting distance.}}$$

*Triangle planting*—

$$N = \frac{43560}{\text{Square of side of triangle}} \times 1.155.$$

*Line planting*—

$$N = \frac{43560}{\text{Distance between lines} \times \text{distance in lines.}}$$

### 9. *Lifting Plants.*

Plants must be lifted with the least possible damage, especially to the root-system, and least of all to the fine rootlets through which the assimilation of nourishing substances is effected. These fine rootlets are generally imbedded in small lumps of earth, which should not be shaken off. In the case of yearlings the rootlets are found on the taproot or its branches; on older plants they are principally found on the side roots.

The least interference with the roots occurs if the plants are lifted with a ball of earth, in which the root-system is imbedded; this method is specially recommended for very young or tender plants. In the case of older plants, lifting with balls and transport become very expensive, so that whenever admissible they are lifted without balls of earth.

#### *a. Lifting Plants with Balls of Earth.*

The operation is performed with a variety of instruments, such as the circular spade, the hoe, the conic spade and the ordinary spade, according to the size of the desired ball.

Young plants, up to a foot in height, may be lifted with the circular spade (Fig. 42), provided the species does not develop a long taproot at an early stage. This instrument, which was invented by Carl Heyer more than 60 years ago, consists of an iron inverted truncated cone, which has in front an opening sufficient to admit two fingers, and behind, just above its upper edge,

a small horizontal plate up to which the spade should be inserted. One of the edges of the front opening is sharp, the other blunt. The diameter at the lower end ranges from 2 to 5 inches, according to the desired size of the ball; the diameter at the upper end is from  $\frac{1}{8}$ th to  $\frac{1}{3}$ th larger, thus producing the shape of an inverted truncated cone with a circular cross section. The handle and the cross bar or crutch at the top are best made of wood and not of iron, because the tool is lighter and the crutch not so cold. The crutch is firmly attached to the handle by means of three iron bands, as seen in the illustration; both are firmly fastened to the spade. The best length of the crutch is about 20 inches, and its thickness such as just to fill the hand of the labourer. The length of the handle depends on the height of the labourer, but it should not be so long as to prevent the man from using the weight of his body in driving the spade into the ground.

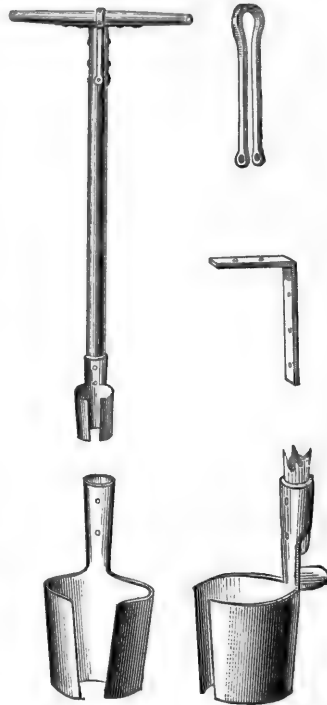

Fig. 42.

In using the spade the stem of the plant which is to be lifted is passed through the front opening until it occupies the centre of the spade; then the latter is

pressed down perpendicularly until the plate at the back touches the surface of the soil ; it is then turned round by means of the crutch from 180 to 360 degrees, and lifted with ball and plant out of the ground ; holding it then with the left hand, the ball and plant are pushed out towards the handle with the middle finger of the right hand, which glides along the blunt edge of the front opening ; if necessary, especially when using a larger sized spade, two fingers are used.

The circular spade is used of various dimensions, with a minimum diameter of 2 inches at the small end. Spades of more than 5 inches diameter cannot be recommended, as the balls are either not severed at the bottom or, even if severed, do not come out with the spade, but remain *in situ*. Even small spades demand a fairly binding soil, or else they will not work satisfactorily. The height of the spade is about equal to the diameter. The ball is cylindrical, the object of the conical shape of the spade being to facilitate its removal. The instrument works expeditiously and cheaply.

The *hoe* is also used for lifting young plants with balls ; it is inserted from one side so as to get underneath the plant, which is then lifted up. The operation requires skill, and even then the method is of doubtful utility, as the balls are likely to fall to pieces. The ordinary *planting spade* (Fig. 29, p. 60) and the *Irish spade* (Fig. 28, p. 60) are used for the lifting of larger plants. The operation necessitates four insertions, and it produces an inverted pyramidal ball. The *semi-circular spade* (Fig. 43) is also used for lift-



ing larger plants; it necessitates only two or three insertions. The *semi-conical spade* (Fig. 44), invented by Edward Heyer, is so constructed that it requires only one insertion, after which it is turned round its axis, thus separating a ball of earth of an



Fig. 43.



Fig. 44.



Fig. 45.

inverted conical shape. The instrument can be recommended.

On stony soil a heavy, specially strong spade (Fig. 45) is sometimes used.

*b. Lifting Plants without Balls of Earth.*

This is best done with the two, three or four-pronged fork (Fig. 31, p. 60), which is inserted from one side

and bent down backward, so that the plants are gently lifted up and gradually separated from the soil.

Another method is to insert two spades or forks from opposite sides, in a slanting direction, so that they meet, or nearly so, underneath the plant; both spades are then bent back and the plant lifted.

Sometimes hoes, ordinary or pronged, are used, but they are inferior to spades or forks for lifting plants.

Pulling up plants injures the roots and should be avoided.

### 10. *Pruning Plants.*

As a general rule plants should not be pruned unless it is absolutely necessary. Every cut produces a wound, exposing the plant to disease, which may ultimately render it unfit for the purpose for which it has been grown. Recent researches have shown that the unhealthy condition of timber trees may be due to spores of fungi entering its tissues through wounds received at a very early age.

Where woods are grown for fuel, or treated under a short rotation, the above consideration is of comparatively small importance; in the case of timber plantations, however, which require long periods of time to mature, the forester will do well to pause before he proceeds to prune his plants. Healthy plants of moderate size can be produced at such a low cost, that it is far preferable to throw away badly shaped plants than to prune them and risk the introduction of disease. In the case, therefore, of small and moderate sized plants pruning should be avoided. Such plants should be so

grown that a compact root-system may be produced which does not require pruning.

Where large plants are used, pruning may be necessary; its execution depends on a variety of circumstances, of which the following may be mentioned:—

*a. Shape and Condition of Plants.*

In the case of plants of a normal shape, especially if the root-system and crown are in proper proportion, pruning is not necessary. In the reverse case, either the root-system or the crown and even the stem may be reduced in extent; of two leaders one may be removed, abnormally strong side branches shortened, inconveniently long tap or side roots reduced. The pruning of one part may necessitate the pruning of the other, so as to establish a due proportion between them; if, for instance, the root-system has been pruned but not the crown, portions of the latter may not receive sufficient nourishment and dry up. Originally normal plants frequently require pruning, because the root-system has been injured in lifting them.

*b. Species.*

There is a great difference in the treatment of plants of different species. Some stand pruning better than others, both as regards the replacement of the pruned parts and the extent to which they are exposed to disease.

On the whole, conifers stand pruning badly. Larch is perhaps an exception, also Deodar and *Pinus longifolia*, though they cannot be pruned to the same extent

as broad-leaved species. The latter recover much quicker, especially species with a strong reproductive power, such as Willow, Poplar, Oak, Hornbeam, Elm, Alder; Beech and Birch, on the other hand, are less vigorous in this respect. Teak stands much pruning of the crown, but less of the root-system.

*c. Locality.*

Under favourable conditions of soil and climate pruning is less injurious than in the reverse case. On fertile fresh soil a comparatively small root-system suffices to fulfil the necessary work of assimilation, and fresh organs are formed in a short time; on dry poor soil, pruning of the roots must be much more restricted.

*d. Manner of Pruning.*

In all cases a clean section should be made; the cut should be somewhat slanting and not at right angles to the branch or root. Where a whole branch is taken off, the cut should be flush with the stem to insure quick healing by occlusion; if it is only shortened it had better be done just above a strong bud.

The operation may be performed with a pruning knife, pruning scissors, shears, or a light hatchet; in the latter case the plant should be placed on a firm support during the operation, so as to injure the remaining wood and bark as little as possible.

11. *Protection of Plants in Transit.*

During transit, plants must be protected against drying up and frost, and this refers more particularly to the root-

system ; a few minutes of exposure often suffices to kill the finer roots. The method of protection depends on the kind of plants, the time during which the plants are in transit, the species and the climate to which they are exposed ; the drier the latter, the more carefully must the plants be protected.

Ball plants possess already a good protection in the lump of earth in which the roots are imbedded. For transport occupying not more than one day, the balls should be packed close together to prevent their drying up, and the earth from being shaken off. Only in rare cases are such plants carried over long distances, the cost being too great.

Plants without a ball of earth should be at once protected. This is best done by dipping the roots immediately after lifting into soft mud, which forms a thin layer over them ; the plants should then be tied together in bundles of convenient size. For transport over short distances, which occupies not more than one day, the bundles should be placed in baskets, wheel-barrows, carts or waggons, according to circumstances, the roots being surrounded by, or imbedded in, moss, grass, or earth. If the weather is dry and the sun shining, some cover may also be provided, to prevent the drying up of the foliage. The moss or grass used to cover them should be well moistened, and this process may be repeated from time to time during transit.

If the transport extends over several days, further precautions are necessary. The small bundles are, in that case, bound together into large packages, by arranging the plants so that the roots are all on one end, well wrapped in wet moss, grass, &c., and then secured by

withes. The whole package is covered with matting. In the case of small or middle-sized plants two layers are packed together with the roots in the centre and the crowns outwards on both sides. Plants packed in this manner keep fresh for a week, provided they are so packed that no heating takes place.

On arrival at their destination the plants should be at once unpacked, and either planted out, or bedded in earth until they can be planted. The imbedding is best done by arranging the small bundles in trenches and covering the roots and part of the stem with moist soil. If necessary, shelter against the sun or dry winds may also be provided, and the plants may be watered.

### 12. *Preparation of the Soil.*

Only in very rare cases does the soil require complete working before planting, and in such cases it is done by one of the methods indicated for direct sowing. As a general rule planting requires only partial working at the spots where the plants are inserted into the ground, or none at all. The worked area of a planting spot ranges upwards from a few square inches, and rarely exceeds two or three square feet in silvicultural operations conducted on a large scale. The actual method of working the soil depends on the method of planting; hence it will be described when dealing with the latter.

## II. *RAISING PLANTS.*

Plants can be procured either by purchase or home production; in the latter case they can be taken from

existing woods, or raised in temporary or permanent nurseries. Although in the majority of cases plants are purchased or produced in home nurseries, the other method may in certain cases be admissible, hence the subject will be divided as follows:—

1. Purchase of plants.
2. Plants taken from existing woods.
3. Raising plants in nurseries.

### 1. *Purchase of Plants.*

In former times the necessary plants were as a general rule grown at home, and this is still the case in many countries. In Great Britain, and of late also in Germany, a highly developed industry of raising plants for sale exists, and in the former country by far the majority of plants are now-a-days purchased from nurserymen. This system is highly convenient, since the planting operations are not interfered with by want of the necessary planting material, while the prices of plants need not be higher than what their cost would be if grown at home. Railway communication, also, is now so extended and rapid that most important species of forest plants can be sent to any part of the country without serious risk to their health and vigour. The art of raising strong hardy plants has been so fully developed by nurserymen, that almost any description of plants is procurable at reasonable rates.

Under these circumstances the purchase of plants is quite justified in Great Britain and in a few other countries, provided the forester takes care that he receives only good healthy plants of the description indicated on

page 72. He must, more especially, see that he receives plants with a properly developed root-system, that is to say one which is full and compact, but at the same time of a natural shape. It has of late years become the practice to lay down the seedlings, when they are pricked out, into shallow trenches involving the bending over of the root-system to one side; the result is a bushy root-system altogether lop-sided. If such plants are put out into the forest, they take many years to recover a normal healthy shape of the root-system, and until this takes place they have only a limited hold on the ground, and are liable to be blown over by strong winds. This drawback is often maintained up to middle age, if not longer.

In selecting plants, care should be taken that they are suited to the locality where they are to be planted. For fertile localities at low elevations, well-grown tall plants are desirable; for poor soil, especially on high elevations, short sturdy plants are preferable. Generally speaking it is best, if no great differences exist between the soil and climate of the nursery and of the locality where the plants are to be put out.

## 2. *Plants taken from existing Woods.*

Where operations are conducted on a small scale, and nursery plants are not available, the planting material may be obtained from existing young woods, such as natural regenerations or sowings. In such cases the plants are taken from the parts which are too thickly stocked, and consequently they are generally indifferently developed; they are slow in coming on



after transplanting, and do not, as a rule, yield good results.

### 3. *Raising Plants in Nurseries.*

Where plantings are conducted regularly on a large scale, plants may be raised in nurseries; and even if the plants are purchased from nurserymen, it is desirable to have an auxiliary nursery at home; hence it is necessary to describe here, in outline, the establishment and management of nurseries.

Nurseries may be temporary or permanent; the former are used for a few years only, generally to yield the material for the planting of a particular locality, when they are abandoned and a new nursery laid out elsewhere; permanent nurseries are used for a long series of years. Each has its advantages and disadvantages. In the case of temporary or shifting nurseries the cost of transport and the risk of damaging the plants during transit are smaller; on the other hand the cost of laying out is greater, as it recurs every two or three years, and they do not as a rule yield equally good plants. Temporary nurseries can be established in localities of the same description as those where the planting has to be done; hence they may be desirable where distinct zones of vegetation occur, especially in mountainous districts, also where the plants are to be put out with balls.

Permanent nurseries require to be manured from time to time, but they yield better plants; they are preferable in the majority of cases, especially in more level districts; where large numbers of plants are required year

after year, and where the transport is fairly easy and cheap. There is practically no difference in the treatment of temporary and permanent nurseries, except that in the latter case all arrangements are of a more lasting nature.

*a. Choice of Site.*

The site should be favourable for the growth of the particular kind of plants which are required. If only one species, or a few of similar requirements are wanted, a site can be chosen which agrees with their special requirements as regards soil and situation. In the majority of cases, however, plants of differing requirements are to be raised, and it is therefore best to choose a site of average conditions.

The most suitable soil is a light or sandy loam. Heavy clay should be avoided, as it is less suitable than even a light sandy soil. Good depth is essential, as it insures a more even degree of moisture.

As regards situation, the site should, if possible, be in the centre of the area where the planting has to be done, but if no suitable locality is there available, it is better to go to a moderate distance in search of it. The site should be accessible and easy of control. A gentle slope is best, or an elevated level plain; in either case it should not be exposed to danger from frost, especially late spring frost; fairly sheltered, but open to the free circulation of air. The aspect depends on circumstances, especially latitude and elevation. In temperate Europe the least favourable aspects are probably an eastern or south-eastern (on account of late frosts) and a southern (on account of the rapid evaporation of moisture).

The site should, if possible, be so chosen, that water can be led on to it from a spring or stream, or that at any rate water may be found at a reasonable depth for the construction of a well.

*b. Area.*

This depends on the species, the method of treatment, the number of plants, whether they are pricked out or not, and the age at which they are finally removed. It is clear that no general rule can be given. By way of illustration it may be mentioned that for raising two-year-old seedlings of Scotch Pine or Spruce, the area of the nursery should be about  $\frac{1}{2}$  per cent. of the area to be annually planted at 4 feet apart; if the two-year-old seedlings are pricked out, and remain for another two years, the nursery should comprise at least 4% of the area to be planted annually.

Where broad-leaved species are raised, such as Oak or Beech, the percentage is rather higher. It increases very rapidly with the age of the plants; for instance in the case of twice pricked out Oaks, which are planted out at the age of 9 years at 10 feet apart, the area would amount to not less than 30%\* of the area to be planted annually.

*c. Shape.*

Whenever a free choice is possible, the shape of the nursery should be that of a square or rectangle, because it admits of a regular rectangular shape being given to the seed beds without waste of area. The latter consideration more than compensates for the small extra outlay on fencing, as compared with a circular shape.

\* According to Heyer.

*d. Fencing.*

The nursery must be thoroughly protected against cattle and game by fencing it substantially. The nature of the fence depends on circumstances (see page 19); it may consist of a stone wall, wooden or wire fence, living hedge, etc. ; stone walls are liable to interfere with the free circulation of the air, while living hedges take some years to grow. Of late years wire fences, if necessary combined with rabbit netting, have grown in public favour.

*e. Draining.*

This will, as a rule, not be necessary, as soil which requires draining should not be chosen for a nursery. Where no other site is available, the draining may be so arranged that the water is collected in a well at the lowest point of the nursery, to be used for watering during dry weather.

*f. Watering.*

As a general rule watering will be required ; hence the importance of choosing a site situated in the vicinity of a spring, stream, or tank, from which the water can be easily brought into the nursery. In the absence of such a supply one or more wells must be sunk, and the water lifted.

The water can be distributed by hand, or by irrigation. The former method is expensive and less effective, so that it should only be employed where irrigation is impracticable. The latter can be done in two ways, by percolation or by flooding, according as to whether the water stands in channels between the beds, or is allowed

to cover the surface of the beds. Flooding is more effective, but it is followed by the formation of a hard crust on the surface, which requires to be broken; in the majority of cases percolation is preferable.

*g. Preparation of the Soil.*

It is highly desirable that the soil of the nursery should be free from stones and roots, and as finely divided as possible, in other words it should be prepared in the same way as garden soil. The depth to which the soil should be worked depends on the species and nature of the desired plants. Where a compact shallow root-system is wanted, it is best not to work too deep, but to see that the surface soil is fertile; if deep-rooted plants are desired, the soil must be worked to a considerable depth. If one or two kinds of plants are to be raised, their special wants can be considered in the first cultivation of the soil; as a rule, however, more species, and those of varying requirements, are wanted, which it is convenient to raise in any part of the nursery. Under these circumstances it is generally preferable to prepare the whole nursery for the production of any kind of plants. In a country with a climate like that of Britain, the best plan is to trench the nursery to a depth of not less than 2 feet. During this operation all stones and roots should be removed, if necessary, by screening, the land levelled as far as practicable, or terraced on sloping ground, and the best earth kept near the surface. The most suitable time for trenching is autumn, so that the ground may lie fallow over winter and be exposed to the effects of frosts

and of the winter rains. In the following spring the soil should again be worked, either with plough, spade, or hoe, and harrowed so as to divide it finely. The nursery operations can then be commenced, or the ground, after manuring, be used during one season for the cultivation of a field crop, such as turnips, mangold-wurzel, or potatoes, so that the additional cultivation may produce a further division of the soil. After the removal of the crop, the ground is ploughed and left fallow over a second winter, when it should be quite ready to serve as a nursery.

#### *h. Manuring.*

On good soil, plants can be raised for a number of years without manuring, but sooner or later this becomes necessary. Although the demands on the soil of a growing crop of trees are comparatively small, yet, through the uninterrupted growing and removal of seedlings, considerable quantities of various substances are taken out of it, which must be replaced. At the same time our knowledge as to the kinds and quantity of materials which must be supplied to the soil is as yet deficient.

Manuring, or amelioration generally, has for its object to improve not only the chemical composition, but also the physical qualities of the soil. If, at the outset, the soil should not be of the proper consistency, it must be improved by the admixture of sand to a stiff soil, and by that of clay or loam to an excessively loose and light soil. At the same time, and at any rate after a few years, the soil can be specially manured by bringing into it stable manure, guano, bone-dust, nitrates, phos-

phates, potash, lime, or magnesia. All such manures are however expensive, and, with a view to recovering a part of the outlay, the soil may be used for one year for the production of a field crop immediately after being manured. This measure is further useful, because it gives the soil a change of crop, while it receives at the same time a thorough working. Scotch nurserymen, as a rule, act as follows: they treat their nursery-ground under a rotation of three or four years, say three, for forest plants, then they manure, take off one field crop, and again use the soil during three years for nursery purposes.

The manure can be supplied by growing a leguminous crop, such as lucerne, and ploughing it in instead of removing it.

In many nurseries considerable quantities of mild manures are used, such as leaf-mould, compost, burned turf, and also charcoal refuse. The leaf-mould is taken from the forest, or specially prepared from dead leaves, needles, forest plants, &c., which are heaped together and allowed to decompose, generally with the addition of a certain amount of quicklime.

Compost is a mixture of humus and soil. It is generally made into heaps, some quicklime added, and then allowed to season, the heaps being turned over from time to time; it should not be used for a year or two. To prevent the compost being washed out by rain-water, it is sometimes stored in pits instead of heaps.

Burnt turf is produced by cutting sods of turf, best from loamy soil, in spring, allowing them to dry, the grassy side downwards, and then burning them in heaps either alone, or better intermixed with brush-wood or

fagots (Fig. 46).\* In constructing such a heap, some brushwood is placed in the centre (*a*) and covered with perhaps three layers of sods (*b*), then comes a second layer of wood (*c*), followed by three or four more layers of sods (*d*). A narrow channel (*m*) is kept open from the circumference to the wood in the centre, by which the latter is ignited. The effect of burnt turf is not of long duration; manuring with it has generally to be re-

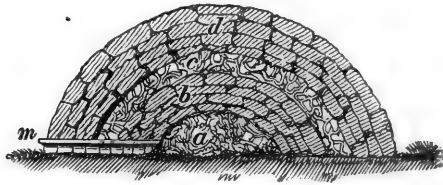

Fig. 46.

peated every year; it acts, however, very favourably upon the physical condition of the soil, somewhat in the same way as humus.

#### *i. Laying out the Nursery.*

The area of the nursery is divided into compartments of convenient size, generally of the shape of a square or rectangle. The number of compartments depends on the number of species to be grown and the age of the plants when put out into the forest. Assuming the latter to be three years, there should be four compartments in each set, to allow each compartment to lie fallow, or be used for the cultivation of a field crop every fourth year.

\* After Heyer.



The compartments should be separated by roads, which cross each other at right angles. Their breadth depends on circumstances; in most cases it is desirable to make the main roads sufficiently broad to admit carts or waggons. The roads are excavated to a depth of 6 to 12 inches, the soil being spread over the adjoining land and then filled in with a layer of macadam or coarse gravel, covered by a thinner layer of fine gravel or sand, in such a manner that the surface slopes gently from the centre towards the sides. A useful measure is to line the roads by an edging of a suitable plant (privet, box, &c.), which helps to keep them tidy.

In the case of heavy seeds, such as acorns, chestnuts, &c., the whole compartment is sometimes sown broadcast, or in lines at such distances that a man can walk between them, and then no further division is required. In the majority of cases, however, the compartments destined for sowing are divided into parallel beds intersected by paths. These beds should not be more than 4 feet broad, so that a man can easily reach from the path to the centre of the bed without treading on it. The paths are of just sufficient breadth to allow a man to walk along them. Where the seed-beds are to be irrigated by overflow, the paths should be on a higher level than the beds, so as to act as embankments to keep the water on the beds.

*j. Sowing the Seed-beds.*

The surface of the seed-beds having been reduced to a fine degree of division, the seed is sown, either broadcast or in lines or drills; the latter is frequently preferred,

as it facilitates weeding. Broadcast sowing is done, as described on page 61, by scattering the seed evenly over the whole seed-bed.

Line sowing may be done by pressing the seed individually into the ground, or by opening out shallow drills at suitable intervals, and placing the seed into these; the drills can run longitudinally over the seed-bed, or cross-ways, the latter facilitating weeding. The depth of the



Fig. 47.

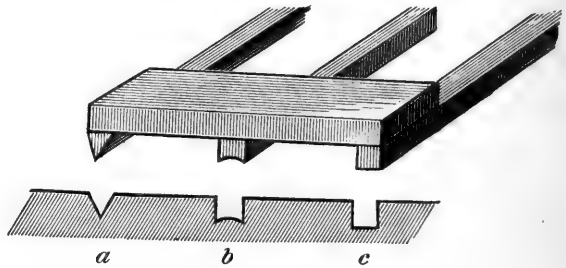

Fig 48.

seed drills depends on the species, and ranges from about  $\frac{1}{2}$  of an inch to 2 inches. Similarly, the distance between the seed-drills depends on the slower or faster development of the seedlings and the time they are to remain in the seed-beds; it varies from 6" to upwards of a foot. The seed-drills can be made by hand, with a peg, or narrow-pointed or trowel-shaped hoe (Fig. 47), or by pressing wedge- or square-shaped battens into the ground (Fig. 48). In fact quite a variety of instruments have been invented for the purpose, Fig. 48, *a*, *b*, *c*, shows three differently shaped drills. The covering of the seed is done by hand, or with the

rake, or by scattering fine earth, compost, turf-ashes, etc., over it to the required depth. In any case it is desirable to press the covering down, best by passing a light roller over the bed.

Sowing should only be done during suitable weather, that is to say when the soil is of the desired degree of dryness. The actual method of sowing depends on the species. By way of illustration some of the methods followed in Britain are here added :—

Heavy seeds, such as *Oak*, *Sweet Chestnut*, *Walnut*, *Horse-chestnut*, etc., are generally sown in lines which are from 12 to 15 inches apart. The seeds are either sown in drills about 2 inches deep and covered by earth drawn over them with a rake; or they are placed on the surface and then covered with earth taken from the space between the rows. In the latter case the seed-rows form slightly elevated ridges. Seeds of the above-mentioned kinds may either be sown in autumn soon after being gathered, or they may be kept over winter in airy places, where they are occasionally turned and perhaps also mixed with some sand.

*Beech* nuts are treated similarly, but the covering should not exceed  $\frac{3}{4}$  of an inch; they are sown more frequently in spring than in autumn.

*Maple* seed is sown, soon after gathering, in lines as before, mostly on the surface and covered with soil to a depth not exceeding  $\frac{3}{4}$  of an inch.

*Elm* seed is sown immediately after it has become ripe, at the end of May or beginning of June, generally in lines about a foot apart; its covering should consist of fine earth placed over it of a thickness not exceeding  $\frac{1}{4}$  of an inch.

*Alder* and *Birch* seeds are generally sown broadcast in early spring, and covered with  $\frac{1}{4}$  to  $\frac{1}{3}$  of an inch of fine mould in the case of *Alder*, and somewhat less for *Birch*.

The seeds of *Ash*, *Hornbeam*, and *Thorn* are mixed with sand and kept from 15 to 18 months in a pit, where they are occasionally moistened and turned. They are sown in early spring of the second year, together with the sand in which they rested; they receive a covering not exceeding  $\frac{3}{4}$  of an inch.

*Larch*, *Spruce*, *Scotch Pine*, and various other *conifers* are sown broadcast in spring on carefully prepared beds. They are sown on the surface and then covered with fine earth; frequently the process consists in scraping a sufficient quantity of soil from the surface of the bed to both edges, then sowing the seed and raking back the earth from the sides towards the centre of the bed. After thoroughly smoothing the surface, a light roller is passed over the bed.

#### k. Quality and Quantity of Seed.

Considering the heavy expenditure involved in laying out nurseries, none but seed of the best quality should be used.

The quantity of seed to be sown on a given area depends on the species and the time during which the seedlings are to remain in the seed-bed. Too dense sowing causes the seedlings to grow up lanky, while too thin sowing involves loss of area and consequently increases the cost. If the seedlings are to go direct from the seed-bed into the forest, the quantity of seed should be about one-half of that sown when the seedlings are to be pricked out in the nursery.

As to the actual quantity of seed to be sown, views differ so considerably, that it is not possible to give average data. In a nursery at Inverness,\* the following quantities of good clean seed are sown per 100 square feet of seed-bed :—

Scotch Pine . . . . .	=	·6 pound.
Spruce . . . . .	=	·6 „
Austrian Pine . . . . .	=	·8 „
Larch . . . . .	=	1·0 „

Biermans, a well-known German sylviculturist, sows about four times the above quantity of seed. Messrs. Howden & Co. consider it a good full crop if one pound of good Scotch Pine seed produces 15,000 seedlings. Biermans expects only 7000.

Gayer gives the following average quantities of seed to be sown in drills per 100 square feet of seed-bed :—

Oak and Sweet Chestnut	=	·05 bushel (at 8 gallons).
Beech . . . . .	=	·13 „
Ash and Maple . . . . .	=	·3 pound.
Elm . . . . .	=	·23 „
Hornbeam . . . . .	=	·18 „
Alder . . . . .	=	·36 „
Birch . . . . .	=	·41 „
Silver Fir . . . . .	=	·82 „
Scotch Pine . . . . .	=	·17 „
Spruce . . . . .	=	·23 „
Larch . . . . .	=	·46 „
Austrian Pine . . . . .	=	·26 „

\* Messrs. Howden & Co.'s Nursery.

Broadcast sowing takes from twice to four times the quantity of seed required for drill sowing; hence Gayer's data for conifers agree fairly well with those given by Messrs. Howden & Co.

*l. Pricking out.*

In some cases the seedlings are taken direct from the seed-bed to the forest; in others they are transplanted once or several times in the nursery before they are finally put out. British foresters call the former "seedling plants," and the latter "transplants."

Seedling plants which are to go direct to the forest must be grown roomy in the seed-beds, so that they may develop properly; plants which are to be pricked out in the nursery may stand closer together in the seed-beds.

Pricked-out plants are generally placed in rows, called "nursery lines." The soil devoted to them must be carefully prepared, though not perhaps quite to the same extent as that of seed-beds.

The area required for nursery lines depends on the species, the age of the seedlings when pricked out, and the time they are to remain in the nursery; on an average it may be estimated at 8 to 10 times the area of the seed-beds, provided the plants are one year old when pricked out, and four years old when put out into the forest.

Seedlings should be pricked out while young; in the tropics the right age is sometimes only a few weeks; in temperate Europe generally one or two years, according to the nature of the species and the locality.

When the object is to produce large and strong plants,

they may be pricked out a second or even a third time, after an interval, each time, of one, two or more years.

Plants may be pricked out at any time, provided it is done carefully, rapidly, and when the soil is fairly moist. In temperate Europe the best time for extensive operations is early spring. Moist weather is desirable during the operation, else the plants may have to be watered. The lifting and protection of the plants during transit have been dealt with above (pages 86 and 92).

The distance between the nursery lines and between the plants in the lines depends on the size of the plants, their more or less rapid development, and the time which they are to remain in the lines. Ordinary 2-year-old seedlings of Scotch Pine and Spruce, which are to remain for two years in the lines, may be placed from 3 to 6 inches apart in the lines, with a distance of 8 to 12 inches between the lines. Larch plants must be placed somewhat further apart, while for Oak the distances are still greater.

Brown, in "The Forester," recommends the following distances:—

One or two-year-old seedlings of Oak, Ash, Elm, and Beech, 4 inches apart in the lines, the latter being 24 inches apart.

One-year-old Larch seedlings =  $16 \times 2\frac{1}{2}$  inches.

Two-year-old Larch seedlings =  $18 \times 3$  „

One or two-year-old Scotch

Pine seedlings . . . =  $14 \times 2$  „

Messrs. Howden & Co., Inverness, generally line out the Larch 1 year old and Scotch Pine 2 years old.

They place them 3 inches apart in the lines, with 9 inches between every two lines.

The pricking out can be done in a variety of ways according to the description of plants. The more usual methods are, either to make a separate hole for each plant with a planting peg, a small hoe, or a garden trowel, or to open shallow trenches, into which the plants are placed at the proper distance apart. In either case the roots should be placed into a natural position, and the soil well pressed around them.



Fig. 49.

British nurserymen, in raising plants for sylvicultural purposes, proceed in the following manner:—

The soil, after having been brought into a suitable condition, is thoroughly smoothed along the whole length of the compartment, then a planting line is placed on it, parallel to one side of the compartment; then the ground is cut away with a spade along the line, so that a shallow trench is formed with one side almost perpendicular (Fig. 49, *a*). Against this side the plants are placed at the proper distance apart, some earth pressed around them, then the trench completely filled up, the earth pressed down once more with the foot, and the whole smoothed over (Fig. 49, *b*). Then the planting line is moved on to the following row and the operation repeated. The method works very expeditiously, and it is an excellent



one in principle. It has, however, become the practice to make the trenches so shallow, that the root-system of the plants, instead of assuming a natural position in the ground, is altogether bent to one side. The result is that the plants develop a lop-sided root-system. It may be easier to put out such plants, besides saving expense, but the system is certainly not favourable to the development and stability of the trees grown from them. The author has observed, that in many cases trees 30 to 40 years old had not yet established a normal root-system, and that numerous trees are blown down for this very reason.

*m. Choice between Seedling Plants and Transplants.*

Each of these two kinds of plants has certain advantages and drawbacks, and it depends on the circumstances of each particular case whether the one or other is preferable.

Seedling plants are considerably cheaper than transplants, as the latter require a larger area, as well as labour in pricking out and tending. On the other hand transplants are much superior, as they have more room to develop; especially the root-system becomes fuller, more bushy and compact.

For planting in favourable localities seedling plants may do as well as transplants; in unfavourable localities the latter are preferable; also when specially large plants are required.

A plan sometimes followed consists in classifying the seedling plants when, say, two years old. The best plants are put out directly into the forest, the second

class plants are pricked out in the nursery, and the third class, comprising the weak and misshapen plants, are thrown away.

*n. Tending Seed Beds and Nursery Lines.*

The seeds, as well as the young plants, require a certain amount of tending, more especially protection against injurious influences. The details of such tending and protecting are given under the head of Forest Protection. In this place only the more important measures directly connected with nursery work will be indicated.

(1.) The seeds must be protected against birds. These may be kept off by shooting or frightening. If this is impracticable, small seeds may receive a coating of red lead, or the beds may be protected by placing on them thorny brushwood, branches of coniferous trees, grass, etc., or nets may be spread over them, resting on supports, so as to keep them at a suitable distance from the ground. The latter have the disadvantage that they must be lifted when weeding has to be done. Wire netting, bent in a semicircle over the seed beds, is most suitable; it needs little or no support and lasts a long time.

Mice, moles, and mole crickets often do much damage; they must be caught or poisoned. Mice may be caught in pots buried in the pathways and half filled with water; these animals are in the habit of running heedlessly along the paths, when they fall into the pots.

Earthworms do damage by dragging small seedlings into their burrows.

Hares, rabbits, &c., must be kept out by fencing, especially wire netting. Squirrels must be shot.

Amongst insects, the cockchafer and the wire-worm are the most destructive in temperate Europe. In both cases damage is difficult to prevent. Cockchafers are specially fond of laying eggs in clearings in the forest, such as a nursery; and if this be repeated once or twice, it may be necessary to change the site of the nursery. Almost the only way to meet the damage in the case of grubs of the cockchafer and the wireworm is to collect them.

(2.) Extremes of climate make themselves felt by frost or drought.

In the first place a considerable fall of temperature interferes with the proper germination of the seeds, and it may injure young seedlings. Such damage is prevented by covering the seed-beds with moss, grass, straw, needles or short branches of Conifers, or by erecting a temporary roof at a convenient height over the seed-beds. Very delicate seedlings may be raised under glass. The covering should be removed during the day and replaced in the evening. Somewhat later on, alternate freezing and thawing may lift the young plants out of the ground; this can be prevented by covering the space between the lines, or by heaping earth on to the plants. If, nevertheless, it should occur, the plants must be speedily put back into the ground.

Damage by drought is prevented somewhat in the same way as that by frost, best by shades, which are placed overhead, or on the sunny side of the beds. If the dry weather should last for some time, the beds may have to be watered. This, if once commenced, must be con-

tinued until rain falls. As watering is expensive, unless it can be done by irrigation with water obtained from a higher point, it is only done when absolutely necessary. Many British nurserymen never water; they prefer taking their chance. In more southern countries watering frequently becomes a necessity. There, also, protection against hot winds is frequently given by shades placed on the side whence the wind blows.



Fig. 50.



Fig. 51.

(3.) Weeding should be done frequently and thoroughly. It can be done by hand, or with knives, weeding-forks (Fig. 50), light two- or three-pronged hoes, the Dutch hoe (Fig. 51), &c.\*

The weeding is generally accompanied by some loosening of the surface soil; but apart from weeding, periodical working of the soil between the nursery lines is highly beneficial.

(4.) If the seedlings come up too thick in the seed-beds, they may be thinned out. In doing this, care must be taken not to disturb the plants which are to

\* Figs. 50 and 51 have been taken from Brades Co.'s Illustrated Catalogue.

remain; hence the best plan is to cut off the weakest plants close to the ground with scissors.

### III. METHODS OF PLANTING.

The most important point in planting is to reduce the interruption of growth to a minimum, so that the plants may quickly establish themselves in their new home. How this object can be realized depends on the description of the plants, their size, and the conditions of soil and climate. To meet the different cases, various methods of planting have been elaborated, of which only the most important will be shortly indicated.

Whatever the methods may be, the following rules for planting are of general application:—

- (1.) The plant should be placed in the ground to the same depth as that at which it stood in the nursery (allowing for a possible settlement of the soil).
- (2.) The root-system should receive a natural position and not be huddled together.

These two rules can only be disregarded under specially favourable conditions.

The actual level at which the plants are placed, depends on the climate and the nature of the soil. In the majority of cases the plants are placed flush with the ordinary surface of the ground; under a dry and hot climate they are sometimes placed in pits or trenches previously dug and arranged at a level below the ordinary surface; in wet or swampy soil plants are frequently placed on mounds or ridges. In either of these cases

the methods of planting remain the same, except in so far as the more limited space may necessitate slight modifications. The preparation of the trenches and ridges has been described above under Direct Sowing (pages 67 and 69). There is, however, a method of mound-planting on ordinary soil, which will be described separately.

In planting, an opening is made in the ground, into which the plant is inserted. The size and shape of the opening depends on the nature of the plant and the tool used for the production of the opening. Accordingly the following methods may be distinguished :—

1. Planting with balls of earth.
2. Planting without balls of earth.
  - a. With hoe or spade.
  - b. With peg or staff.
  - c. Notching.
3. Mound planting.

#### 1. *Planting with Balls of Earth.*

*Preparation of the Planting Hole.*—This depends on the size of the ball. Small and middle-sized plants lifted by the circular or semi-conical spade respectively (page 86), are placed into holes made with the same instruments; such holes are wider by the thickness of the iron than the breadth of the balls, which can thus be easily inserted.

For plants with large balls, the pits must be considerably larger than the balls; they are made with the hoe or ordinary spade.

*Putting in the Plant.*—The top of the ball should be

on a level with the surface of the soil, except in dry localities, when it may be somewhat lower, so as to collect an extra supply of water near the plant. The interval between the ball and the walls of the pit must be carefully filled up, either with earth, compost, turf ashes, or by pressing the soil down until the interval completely disappears.

On dry soil it is desirable to place two pieces of turf over the ball and the adjoining soil, so as to prevent evaporation and shrinking.

*Value of Method.*—This depends in the first place on the extent to which the root-system is contained in the ball. If, during the act of lifting the ball, considerable quantities of the finer roots have been severed (Fig. 52), the results may be disappointing. Hence young ball plants do better, comparatively speaking, than older and larger plants.

Secondly, a thorough touch between the ball and the walls of the pit is essential to success; it follows that ball plantings are better adapted to loose than to stiff soils; the latter as well as the ball shrink during dry weather, so that frequently the ball becomes completely separated and the plant dries up.

On the whole, however, the method is one of the safest, and is specially recommended for loose soils,

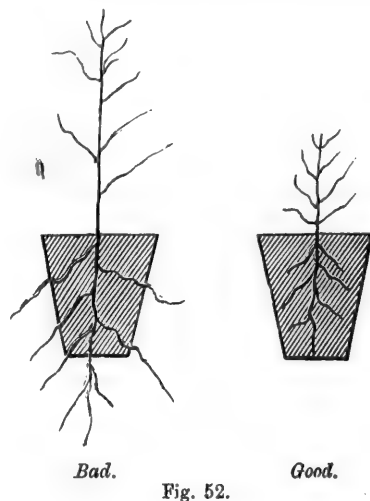

frost localities, and where damage by cockchafers is apprehended; in fact for unfavourable localities generally. It is less suited for stony or stiff soils.

The expense of planting is not high with small ball plants, but increases rapidly with the size of the balls.

## 2. *Planting without Balls of Earth.*

### a. *Planting with Hoe or Spade.*

*Preparation of the Planting Hole.*—After removing any covering which the soil may possess, the pit is made with the hoe, semi-circular or ordinary spade, if necessary with the pick. The size of the hole depends on the extent of the plant's root-system, and the nature of the soil. If the latter be rich and fairly open, the hole need not be larger than the spread of the root-system. On stiff soil the pit may usefully be made somewhat larger and deeper, so as to give an additional amount of working and loosening. On favourable soil the pits may be made immediately before planting; on unfavourable soil it should be made in the previous autumn, so as to expose the earth to the effects of the winter frosts. The soil taken out of the pit should be placed in two heaps, the good soil being kept separate from the rest.

*Placing the Plant.*—In placing the plant in the pit, it should be held in such a manner that the root-system may assume a natural position, then the earth is gradually filled in, so as to get well round the rootlets; first pressed on gently, then somewhat more firmly, and finally pressed down with the foot. The best part of the soil should be brought into contact with the rootlets, and the worst placed on the top. Manure, such as compost, turf



ashes, &c., may be given ; it is placed around the roots. After the operation has been completed, the surface around the plant may be covered with turf, moss, or stones to assist in the preservation of moisture. In dry localities the pit may be made somewhat deeper and not altogether filled up, so as to collect water round the plant.

Of special use during the operation is a small one-



Fig. 53.

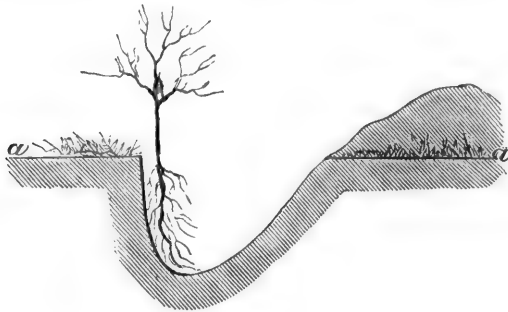

Fig. 54.

hand hoe (Fig. 53), which is used to break up the soil and to scrape it together and on to the plant.

With a view of facilitating the operation, the pit is sometimes given a perpendicular wall on one side against which the plant is held (Fig. 54) while the soil is placed round the root-system ; it has this disadvantage, that the root-system is pushed somewhat to one side.

The operation as above described requires two persons, best a man and a boy ; the latter holds the plant, whilst the former fills in the earth. To obviate the employment of a second person, an arrangement, as indicated in Fig. 55, has been recommended for use in planting out large plants. It consists of an iron rod fixed in the ground near the planting pit and bent at right angle

over it. At its end it has a second springy piece of iron, so that the stem of the plant can be pushed between the two, and the plant held in a suitable position. The advantages of the instrument are that the plant can be held in a perpendicular position, and that the planter has both hands free to operate with.

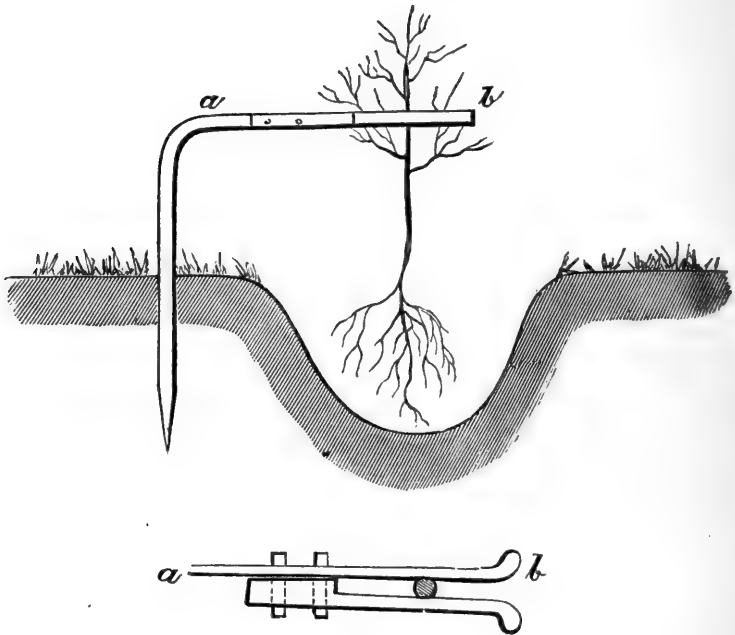

Fig. 55.

During the operation of planting, manure can be added. Biermans adds turf ashes prepared as shown on page 104. The method of planting is indicated in Fig. 56. The planting hole having been made with the spiral spade (Fig. 34 on page 66), a quantity of turf ashes is pressed against one side (at *a*), then the plant is placed in the hole, a second handful of turf

ashes pressed against it (at *b*), then the better part of the excavated earth is filled in and placed at *c*, and the rest of the hole, if any space should be left, filled up with the less good earth. Finally the earth is pressed together by placing the foot at *d*.

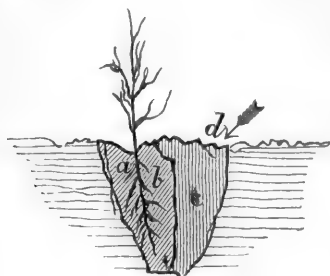

Fig. 56.

*Value of Method.*—It is simple and can be applied to any kind of plants, or any soil, except perhaps very wet or shallow soils. It is specially adapted for large plants, particularly those with an extensive root-system. The cost depends on the size of the pits.

*b. Planting with Peg, Staff, or similar Tools.*

Planting with a peg is done in the case of young plants which have not as yet developed side roots of any length. It is specially adapted for the cultivation of dry localities with plants which have been raised in such a manner as to develop long tap roots, to bring them into contact with moisture lodging at some depth.

In order to guard against the plants being choked by weeds it is frequently necessary to work the soil before planting, either entirely, or in strips or patches. This can be done with a light plough or the hoe. In such

cases the area may be used for the raising of a field crop before planting.

Pegs of various shapes are used, such as the ordinary



Fig. 57.



Fig. 58.



Fig. 59.

planting pegs (Fig. 57), the planting dagger (Fig. 58), Buttler's iron (Fig. 59), &c. The planting peg is constructed of wood; Fig. 58 shows a wooden peg with an

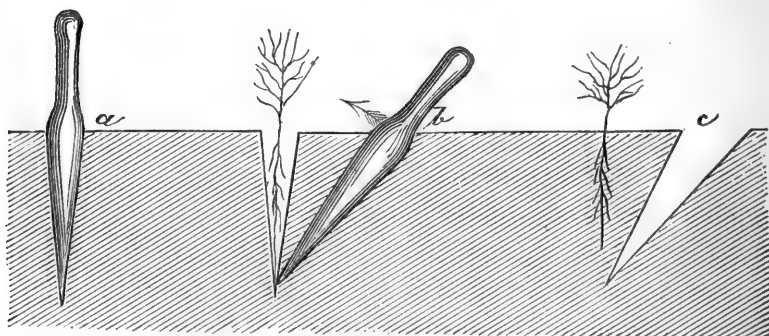

Fig. 60.

iron coating up to the handle; Buttler's tool is made entirely of iron, the handle being covered with leather; it weighs about seven pounds.

When using any of these tools the planter holds a bundle of plants in one hand and the tool in the other; he inserts the tool into the ground (Fig. 60, *a*), takes a plant out of the bundle, holds it between two fingers, withdraws the tool, inserts the plant into the hole, re-inserts the tool in a slanting position (Fig. 60, *b*), and presses earth on to the plant by pushing the peg towards it. The second hole thus produced (Fig. 60, *c*), can in its turn be filled up by inserting the tool a third time, or by pressing earth into it with the foot.

In these plantings the root should go down straight into the hole, and not be doubled up. To facilitate the operation of insertion, and to protect the fine roots against drying, they are frequently dipped into soft mud as soon as they have been lifted.

The method is cheap and of great despatch, especially if it is not necessary to work the soil beforehand. It is specially adapted for light sandy soil, less for stiff soil, or for a locality which is likely to be overrun by weeds. The plants should not be more than two years old, or else they will have developed too long side roots. Seedling plants only should be thus planted.

Where deeper holes are required, or on stony soil, the planting staff (Fig. 61) may be used. It is a much heavier tool, weighing about 11 pounds, and two men,



Fig. 61.

or a man and a boy, are required for the operation, one making the holes and the other inserting the plants.

*c. Notching.*

This method differs from planting with a peg in the shape of the planting hole, which is that of a notch. The tools ordinarily used are the planting hatchet (Fig. 62), the notching spade (Fig. 63), and the ordinary spade. The hatchet is inserted into the ground with

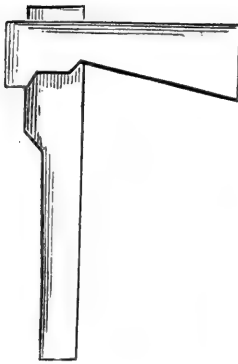

Fig. 62.



Fig. 63.

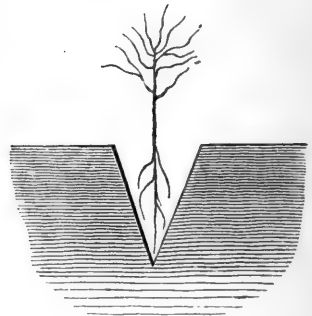

Fig. 64.

one hand and pulled out again, thus producing a notch, in which the plant is inserted; the notch is closed by knocking the adjoining earth into it with the thick end of the hatchet; finally the soil is pressed down with the feet.

The notching spade is wedge-shaped, and after insertion into the ground an enlarged notch (Fig. 64) may be

produced by swaying it to and fro. The tool requires two persons, one making the notches, and the other inserting the plants, filling in, and pressing down the earth with his feet. The common spade can be used in the same way as the notching spade.

In Great Britain notching is done in a somewhat different way, generally with the ordinary spade, so as to produce a T-shaped or a triangular notch, mostly the former. The spade is inserted into the ground (Fig. 65, *a*) and withdrawn; then it is a second time

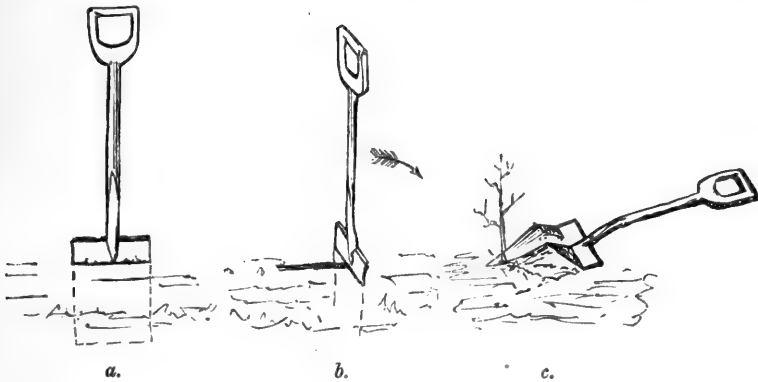

Fig. 65.

inserted at right angles to the first insertion and at one end of it (Fig. 65, *b*); next the handle is bent backwards, thus raising and opening out the edges of the first notch (Fig. 65, *c*); then the plant is slipped in from the blade of the spade towards the far end of the first notch, the spade withdrawn and the soil pressed down with the feet, so as to cause the notches to close completely. The operation requires two persons, a man and a boy.

The merits of ordinary notching are very much the

same as planting with a peg. As regards the British method of notching it must be noted that the root-system obtains an altogether unnatural position, it being completely pressed to one side (compare Fig. 49, *b*, on page 112). It has been already pointed out in that place, that often many years pass before this drawback is overcome. The system as practised in Britain can only yield satisfactory results under a favourable climate and in the case of certain species. It is chiefly employed in planting Scotch Pine and Larch plants two to four years old.

### 3. *Mound Planting.*

Apart from wet and swampy localities, planting is sometimes done on mounds, instead of in pits.

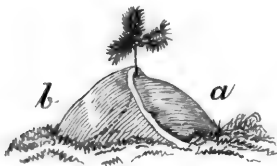

Fig. 66.

The mounds are formed either by scraping together the ordinary soil, or by depositing a basketful of specially prepared soil at regular intervals. The plant is inserted into an opening produced in the centre of the mound, and then the soil pressed

round the roots until the mound has been re-formed. Finally the mound is, whenever practicable, covered with turf, to protect it against rapid drying. For this purpose two pieces of turf are placed, one on the shady side (*a*), and the other on the sunny side (*b*), so that the latter overlaps the former (Fig. 66). In the absence of turf, stones may be placed on the mound.

The method is only suited to plants with a shallow root-system, if the mounds are to be of moderate size. It has yielded good results on soil, such as gravel or



hard clay, where the striking of the plants under ordinary planting would have been doubtful. The expenses are higher than in the case of pit planting, but not by very much, since the method contemplates only small mounds.

Where mound planting is adopted against an excessive degree of moisture in the soil, the mounds must be considerably higher and larger than in the method just described. The expenditure is further increased if the planting is done on continuous ridges, prepared as described on page 30.

#### IV. PLANTING WITH SLIPS, LAYERS AND SUCKERS.

Plants of these kinds are used in the case of species which do not readily seed, or the seed of which germinates indifferently, or for the purpose of obtaining at once plants of some size. Such methods are only auxiliary in temperate Europe, except in the case of Willows and Poplars.

##### 1. *Slips.*

A slip or a cutting is a rootless plant, which consists of a piece of young green wood taken from the stem or a branch of a rooted plant; when inserted into the ground, it develops roots and crown.

Slips may retain the leading shoot or be truncated. The former consist as a rule of stool shoots; the latter can be taken from stool shoots or from the branches of older trees, their length differing from a few inches up to ten or more feet.

In some cases slips are in the first instance placed into nurseries until they have become rooted, but they are generally planted out at once in the forest. The insertion

into the ground can be done in various ways, such as placing the slips in furrows and covering them by drawing a second furrow with the plough; they may also be placed in ditches, trenches, pits, or each slip simply pushed into the ground to the required depth.

When entire slips are used, only the lower portion is inserted into the ground; of truncated slips only a small part remains above the surface. In order to insure striking and a proper development, the ends of the slips should be cut sharply and smoothly in a slanting direction, and each slip must contain some buds, of which at least one, or better several, must be above ground; those below ground may be nipped off. It is also essential that the bark should not be injured at the ends; hence pushing the slips into the ground without a previous opening is only admissible in very loose soil.

The best time for planting slips is early spring, shortly before the buds begin to swell, though they can, under favourable circumstances, be planted at other times, even during the growing season. The roots formed after planting come from the callus produced at the lower end or from the bark.

In England the stools of osier beds are recruited by slips, which are mostly entire; on the Continent truncated slips are used in preference.

## 2. *Layers.*

Layers are branches, or stool shoots, which have been bent down and partly buried in the soil; they develop roots at the buried portion, and when this has taken place, they are severed from the mother tree and represent independent plants ready to be put out. The

formation of roots may be expedited by removing some of the bark of the layer below ground on the side of the parent tree.

Where large numbers of layers are required, the most suitable plan is to produce stools which send out numerous shoots. Each of these shoots is then bent



Fig. 67.

back and fastened into the ground, where it remains until rooted (Fig. 67). In England both the Lime and Elm are propagated in this manner.

### 3. *Suckers.*

The root from which the sucker has sprung is cut through, clean and slanting, on both sides of the base of the sucker, the latter lifted out of the ground and put out into the forest. The method is rarely used, as disease is likely to be introduced through the cut ends of the root.

In some cases pieces of roots are planted out, which produce roots and shoots.

*Note.*—Grafting and Budding, being outside practical Sylviculture, will not be dealt with in this volume.

## SECTION II.—NATURAL REGENERATION OF WOODS.

Natural regeneration can take place by seed, or by shoots and suckers. Accordingly the subject divides itself naturally into two parts. Regeneration by seed is applicable to all species ; that by shoots and suckers applies only to broad-leaved species, since the power of reproduction of Conifers by shoots is either absent altogether, or at any rate so feeble that it is useless for silvicultural purposes.

## A. Natural Regeneration by Seed.

Under natural regeneration by seed is understood the formation of a new wood by the natural fall of seed, which germinates and develops into a crop of seedlings. The trees which yield the seed are called the *mother trees* ; they may either stand on the area which is to be re-stocked, or on adjoining ground. Accordingly a distinction is made between—

- (1.) Natural regeneration under shelter-woods ;
- (2.)     ,,             ,,             from adjoining woods.

## I. NATURAL REGENERATION UNDER SHELTER-WOODS.

The area is stocked with seed-bearing trees, and the new generation springs up under their shelter ; for some time, at any rate, the area bears the new crop and part of the old one.

The system is that which occurs in primeval forests. When a tree falls from old age, or other cause, and an opening is thus formed in the cover overhead, the seed

falling from the adjoining trees germinates and develops into seedlings; these grow up under the shelter of the older trees, until they in their turn become mother and shelter trees. In this manner primeval forest, if undisturbed, goes on regenerating itself for generations. The process is a slow one, as the young crop will only develop when sufficient light is admitted by the fall or death of the old trees. In Sylviculture it is accelerated by the artificial removal of a portion of the old trees, when they have become fit for economic purposes. By degrees, modifications have been introduced, which lead to a number of distinct methods. Of these, the following demand special notice:—

(1.) *The Selection System*.\*—The age classes are evenly, or approximately evenly, distributed over the whole area of the forest. Throughout its entire extent the oldest, largest, and diseased or defective trees are year after year, or periodically, removed, followed by the springing up of new growth in small patches or single trees.

(2.) *The Group System*.—The age classes are distributed over the forest in groups of moderate extent. The oldest groups are regenerated first, then the next oldest, and so on, until the whole forest has been gone over. Some modifications of this system have been introduced, which will be explained further on.

(3.) *The Compartment System*.†—The age classes are so far separated, that each occupies a distinct portion of

\* The term *selection system* was introduced in India; it is perhaps not an ideal term, since a certain amount of selection is practised in all systems; it has been retained, as none better is at present available. The system is called *Femelbetrieb*, or *Plänterbetrieb*, in German, and *Jardinage* in French.

† *Femelschlagbetrieb* in German, and *Méthode par coupes successives* in French.

the area, representing an even-aged, or approximately even-aged, wood. Each wood comprises one or more compartments, and either the whole, or one compartment at a time, is regenerated simultaneously, so that the old crop is replaced by a young even-aged wood.

(4.) *The Strip System.*—This is a modification of the compartment system, each compartment receiving the shape of a strip. As it differs from the compartment system in some respects, it will be dealt with separately.

The limits between the several systems are not always clearly defined, as will be seen further on, but there are certain general conditions of success which hold good for all. Amongst these the following may be mentioned:—

- (1.) The mother trees must be capable of producing good seed in sufficient quantity.
- (2.) The soil must be in such a condition that it forms a good germinating bed.
- (3.) The young seedlings must have sufficient light to grow up, and yet they must, if tender, be protected against external injurious influences.
- (4.) The fertility of the locality must be duly preserved by protecting the soil against the sun and air currents.

These conditions, if not naturally existing, must be produced by timely and judicious interference. The measures adopted for the purpose consist in—

- (a.) Cuttings so executed that they produce the desired conditions.
- (b.) Artificial preparation of the germinating bed, if this should be necessary.

The several systems comply with these conditions in a varying degree. In order to bring out the general characteristics of the methods, it is desirable to commence with a description of the compartment system.

1. *The Compartment System of Natural Regeneration under Shelter-Woods.*

The regeneration occurs approximately at the same time and uniformly over a whole wood, which, for convenience sake, is here called a compartment. The area treated at one time and in a uniform way is called the regeneration area. The new crop should, if possible, be created by one seed year over the whole regeneration area; this, however, succeeds only in exceptional cases, so that, as a rule, two or even more seed years are required to complete the regeneration. As a consequence the regeneration process may extend over a term of 5, 10, 15, and sometimes even more years, resulting in a new crop which is only approximately even-aged.

The cuttings are made from time to time as required, and so that the old or shelter-wood gradually makes way for, and is replaced by, the new crop, the process being as uniform as practicable over the whole regeneration area. These successive cuttings are, for convenience sake, generally arranged into three groups, each of which represents a distinct stage, namely,—

- (a.) The preparatory stage.
- (b.) The seeding stage.
- (c.) The final stage.

Theoretically speaking, the preparatory and final

stages each comprise several cuttings, and the seeding stage only one, but their actual number depends on the circumstances of each case, as will be seen from the description given below.

*a. Preparatory Stage.*

There is a time in the life of every wood which is most favourable for natural regeneration; it occurs during the period of maturity, but differs somewhat in accordance with the special conditions of each wood. That time is, theoretically speaking, the best for the process of regeneration, but other important considerations may not always permit of this particular period being taken advantage of. Only in rare cases have the trees at that time reached a profitable size for economic purposes; hence they must be allowed to grow on for a series of years, and thus pass the most favourable period. In other cases, where only small material is required, the object of management may demand cutting over before the most favourable period for regeneration has been reached.

Every such deviation creates obstacles to successful regeneration. Either the trees are not in the best period of life for the production of good seed in sufficient quantity, or the soil is not in the best possible condition to serve as a germinating bed. It is the object of the preparatory cuttings to counteract these and other drawbacks, which require to be more fully explained.



## i. PREPARATION OF A SUITABLE SEED-BED.

The soil must be brought into a condition which ensures a proper germination of the seed, and enables the seedlings to reach the mineral soil with their rootlets within a reasonable period ; it must be suitably porous and moist. The necessary measures to ensure this depend on the previous condition of the soil and wood, and on the nature of the locality.

In the course of a rotation crowded woods produce considerable quantities of humus, which decomposes at a quicker or slower rate according to species and other circumstances. Where, on approaching the period of regeneration, the layer of humus and leaves is so large that seedlings cannot reach the mineral soil within a few weeks after germination, it must be reduced before regeneration is attempted. This is done by removing some of the trees, and thus admitting the sun's rays and a more active circulation of air, which cause an accelerated decomposition of the humus. The severity of the cutting depends on the original density of the leaf-canopy ; dark cover overhead demands a heavy cutting ; a thin cover, a light cutting or none at all. It also depends on the nature of the soil ; over limestone the humus decomposes rapidly, on cold heavy soil slowly. Again, the leaves of some trees decompose more rapidly than those of others.\*

Situation and the local climate must also be considered. Where the degree of moisture in the soil and the air is high, decomposition proceeds at a slow rate ; such localities are high situations, northern aspects, moist

\* See page 148 of Volume I.

valleys, the shores of lakes and the sea. In all such cases the preparatory cuttings must be comparatively heavy.

On the other hand, in localities which are liable to be overrun by a heavy crop of grass or weeds, the cuttings must be light, or else the young seedlings will be choked.

Generally, the most suitable condition for germination has been reached, when the covering of the soil has been so far reduced that the mineral soil can here and there be seen through it, without being altogether exposed; the seedlings will then be able to establish their rootlets in the mineral soil at an early stage, and thus escape the danger of being killed off by a subsequent spell of dry weather. If, at the conclusion of the preparatory stage, this condition has not been reached, a portion of the humus and leaves or moss may have to be removed artificially, or mixed with the mineral soil below.

In many cases the vegetable covering of the soil has already been too much reduced by a premature interruption of the leaf-canopy, so that the most favourable condition of the seed-bed is past, the soil having become hard and dry, or overrun by grass and weeds. In such cases further cuttings would only increase the evil, and must therefore be omitted; a suitable seed-bed is in that case secured by working the soil immediately before or after the seed falls. The working of the soil may consist merely in removing the weed growth, or in hoeing it up either entirely or in strips or patches, causing it to be broken up by pigs, raking, harrowing, or even ploughing it with a light forest plough. Generally speaking, this operation is known as "*wounding the soil*," and is

considered a most important cultural measure. At the same time it is expensive, and should be executed only when necessary.

#### ii. STRENGTHENING THE SHELTER TREES.

After the ground has actually become stocked with seedlings, only a certain number of the trees forming the original wood will remain on the ground to afford shelter to the young crop and the soil. If all the rest of the wood were removed at one cutting, so that the above-mentioned shelter trees were suddenly brought from a crowded into a comparatively open position, they would probably be thrown by the first gale. To avoid this they must only gradually be placed in a more open position, so as to obtain a firmer hold of the ground. This is done by the preparatory cuttings.

The trees which are to form the ultimate shelter-wood must be selected from the beginning; they should be trees with neither exceptionally broad nor narrow crowns, but healthy trees with medium crowns. These must gradually be led over from a crowded to a more open state. It follows that, from this point of view, the preparatory cuttings are of more importance in the case of shallow-rooted species and very dense woods than under opposite conditions.

#### iii. STIMULATING THE PRODUCTION OF SEED.

In some cases placing the trees in a more open position has a beneficial effect upon the production of seed, but this cannot always be relied on, as frequently such a measure is followed by increased production of wood instead of seed.

## iv. DISTRIBUTION OF THE YIELD.

If forest trees were in the habit of producing seed regularly every year, arrangements might be made to place annually a suitable area into the seeding stage, and thus distribute the cuttings equally over successive years. As, however, most forest trees produce abundant seed only after irregular intervals, it is necessary to take full advantage of every such opportunity and then to bring as large an area as possible into the seeding stage. If no preparatory cuttings had been made, such a treatment would lead to an excessive yield in every seed year, and little or no yield in other years. Hence preparatory cuttings fulfil the further duty of assisting in the proper distribution of the yield.

## v. NUMBER AND CHARACTER OF CUTTINGS.

Whether the preparatory stage should comprise one or several cuttings cannot be determined beforehand; it depends on the circumstances of each case. Sometimes such cuttings are altogether unnecessary or undesirable, in others one good cutting suffices, and in others again two or even more are required.

The period over which the preparatory stage extends comprises sometimes only a few years, in others as much as ten or even more years. In the latter case the cuttings should be light and frequently repeated. Generally, the cover should not be interrupted to any considerable extent during the preparatory stage, except towards the end of it.

In selecting the trees to be cut during this stage, a commencement is made with diseased trees, and all

species not required or desired for reproduction; then trees with bad crowns are chosen, followed by those with exceptionally broad crowns, care being taken throughout that the trees destined for the ultimate shelter-wood are as evenly as possible distributed over the area.

*b. Seeding Stage.*

If the process of preparatory cuttings has been allowed to take its regular course, it will result in the locality being gradually brought into a condition fit to produce a new crop, which springs up and occupies the ground. Such is, however, rarely the case in practice, because the seed years come at irregular intervals; hence, to avoid the risk of opening out the old wood too early, it is desirable to hold back a little with the preparatory cuttings. When a seed year actually comes, the regeneration area is generally not quite ready for it, and it is found necessary to make an additional cutting, which is called the "seeding cutting." By this measure all trees are removed which are not required afterwards for shelter or the production of seed.

It is evident that the seeding cutting should only be made when the seed is actually on the trees and sufficiently advanced to be depended on. The cutting can be made shortly before, during, or after the fall of the seed. Cases in which this rule may be departed from are comparatively rare, for instance, on thoroughly fresh or moist soil, and in the case of a species which seeds regularly every year.

The important question at this stage is the density of the shelter-wood which remains after the seeding cutting

has been executed. That density must be such as to ensure the most favourable conditions for the further advancement of the young crop ; in other words it must afford sufficient light to the young crop without exposing it to injury by frost, drought, or excessive weed growth ; at the same time there must be sufficient shelter left to affect the general factors of the locality beneficially.

It will be easily understood that, apart from the species, the density of the shelter-wood depends on a variety of circumstances, of which the following may be mentioned :—

i. CONDITIONS OF THE LOCALITY.

The shelter-wood should afford protection against the drying up of the soil, frost, cold winds, growth of weeds, and perhaps also against damage by insects. In localities where the young crop is threatened by one or more of these dangers, the shelter-wood must be kept dark : amongst them may be mentioned poor, loose, stony soils ; southerly and westerly aspects ; steep slopes ; localities exposed to dry or cold air currents or to great changes of temperature in spring resulting in late frosts ; those inclined to a strong growth of weeds, especially calcareous soils ; where wind-falls are apprehended, or where cock-chafers and other insects are likely to settle. Where the opposite conditions prevail, in other words on generally favourable localities, the shelter-wood may be less dark, with a comparatively light cover overhead.

ii. CONDITION OF THE SHELTER-WOOD.

Old trees have comparatively denser crowns than younger trees. Tall trees give less shade than short

ones. Both circumstances must be considered in determining the number of trees to be left for the shelter-wood.

iii. DEGREE OF PREPARATION ARRIVED AT DURING THE PREPARATORY STAGE.

The higher that degree, the lighter may be the shelter-wood, other conditions being the same. Whenever the preparation has been insufficient or faulty, it is desirable to keep the shelter-wood comparatively dark, because the seeding may fail or be incomplete, so that a second seed year must be awaited before the area becomes completely stocked with a new crop.

iv. SPECIES.

Above all, the nature of the species determines the density of the shelter-wood. Tender species, especially those of slow growth during youth, require a dark shelter-wood; hardy, light-demanding, quick-growing species a much lighter one. In the case of the latter, the distance of the shelter trees may be only governed by the distance to which the seed is naturally disseminated.

v. GENERALLY.

The cover of the shelter-wood should be as even as possible throughout, whenever the conditions are uniform over the whole regeneration area; if they differ from place to place, the shelter-wood must be arranged so as to suit the changes. Along the edges of the wood, especially where exposed to dry, cold or strong air currents, the shelter-wood should be kept dark, and it may even be necessary to provide beforehand a special shelter-belt.

As already indicated, the shelter-wood should consist of healthy trees with moderate-sized elevated crowns. If trees with low crowns have to be selected, it is useful to prune the lower branches away to a height of 15—20 feet.

The time for making the seeding cutting may be, as stated above, shortly before, during, or after the fall of the seed; it must be concluded and all the material removed before the seed begins to germinate. In felling the trees care must be taken not to injure those which remain as the shelter-wood.

The proper time has now arrived for considering whether any artificial working of the soil is required. Should this be the case, it can be done as indicated on page 138. Where root wood is saleable and the removal of the stools desirable on other grounds, the trees comprised in the seeding cutting may be grubbed out, thus insuring a considerable amount of working the soil.

If the working of the soil is done after the seed has actually fallen, the latter is thereby brought into the ground. The depth of such working depends on the nature of the seed; it may be deeper for large seed, such as acorns, beech nuts and chestnuts, but it must be shallow for small seeds.

From this time forward the regeneration area must be carefully protected against the removal of litter, cattle grazing, and grass cutting.

### *c. Final Stage.*

The final stage comprises the period from the execution of the seeding cutting, until the ultimate removal of the shelter-wood.



The principal objects of the shelter-wood, after the ground has been stocked with a crop of seedlings, are to protect the young growth against various dangers, and to preserve the activity of the soil until the new crop can undertake that duty. At the same time the shelter-wood will act obstructively as regards the admission of light and precipitations, and it must, therefore, not be left longer than is actually required. Its removal is effected, so as to meet these various requirements, by one or several successive cuttings executed at intervals of one, two or more years. The rate at which, or the time within which, the removal takes place depends on various considerations, such as the following:—

i. ACTIVITY OF THE SOIL.

The preservation of a suitable degree of moisture in the soil is of first importance. Owing to the action taken during the preparatory stage, the degree of moisture in the soil may have been seriously imperilled. From the moment that a new crop has actually sprung up, the considerations which prompted the measures taken during the preliminary stage disappear; it becomes the duty of the forester to do his utmost to give the soil all the shelter available after due consideration of the requirements of the young crop, and to re-establish as quickly as possible a fresh and substantial layer of humus on the ground.

Until the new crop closes overhead, therefore, the old wood must provide a certain amount of shelter, and the leaves falling from it will form the nucleus of the new soil-covering. On steep slopes the remaining shelter-

trees help also to prevent damage by water rushing down the hill side. At the same time the cover of the shelter-wood during the final stage is already much interrupted, and not too much must be expected from it; in some cases it may even act injuriously, as it may deprive the soil of more rain-water and dew than is preserved by the beneficial action of the crowns of the trees.

ii. FROST.\*

As regards frost, the shelter-wood does good service by reducing radiation; it is less effective against cold air currents, unless it is supplemented by a dense shelter-belt or wind-break along the edges of the wood. Most species are liable to be injured by frost during early youth, and some require protection against it for a considerable number of years.

iii. WEEDS.

Here again the shelter-wood acts beneficially, by preventing, or at any rate retarding, the springing up of weeds; thus giving time to the new crop to increase in height before it has to contend with them.

iv. INSECTS.

Experience has shown that damage by insects is in many cases less pronounced under a shelter-wood than on clear cuttings.

v. LIGHT.†

As regards light-requirement, most species could miss the shelter-wood altogether were it not required on

\* See page 115 of Volume I.

† See page 116 of Volume I.

account of other considerations. In the case of some species a free admission of light is absolutely necessary shortly after the new crop has sprung up; others will bear a certain amount of shade, but only for a limited period.

vi. GENERALLY.

From what has been said it will be seen that, the forester has to choose between various evils, when deciding on the proper density of the shelter-wood in the final stage; he must ascertain which of these contradictory demands are the strongest, and act accordingly. On the whole he will do well to follow a middle course.

Although under these circumstances it is impossible to give a definite rule for the number and strength of the cuttings in the final stage, it may be useful to give the following directions:—a *lighter* shelter-wood is indicated on north and east aspects, in localities with a short vegetating season such as high altitudes, localities not exposed to cold winds or to rapid weed-growth; a *darker* shelter-wood is desirable in frost localities, on south and west aspects, and where a luxuriant weed-growth may be expected.

Above all, the rapidity and strength of the cuttings in the final stage must be governed by the rate at which the young crop develops. Where it is coming on well, showing strong shoots with fresh green foliage and full buds, the shelter-wood is sure to possess the right degree of density; if, on the other hand, the new crop consists of weak thread-like plants with feeble crowns, pale foliage and thin buds, the shelter-wood requires thinning.

As regards the *severity and number of cuttings* it may be given as a general rule, that a gradual change from a dense to a thin shelter-wood is the best mode of procedure. Where extensive areas have to be dealt with, such a constant attention to each wood is not always practicable, and the number of cuttings must be limited and distributed at intervals of several years. The first cutting, in the final stage, is generally made when the young crop is two or three years old, the others following at similar intervals according to requirements. The last cutting, or final clearing, must not be delayed too long, as a thin sprinkling of shelter trees may do more harm than good.

The *distribution of the yield* over the several years and the state of the market frequently interfere with the timely execution of the cuttings. Similarly the occurrence of a seed year may necessitate a suspension of cuttings in the areas standing in the final stage. These matters are not conducive to a healthy development of the young crop, but the drawback is to some extent compensated by the heavy increment laid on by the shelter-trees, which increase rapidly in size and value.

The *absolute duration of the final stage* differs considerably according to species and the special conditions of each locality. In the case of some light-demanding hardy species, and in favourable localities, it may not be longer than from three to five years; while it may extend over 10, 15 and even more years in the case of tender species, in unfavourable localities, and where the object is to increase the size and value of the shelter-trees in their roomy position.

In executing the fellings in this stage special care must be taken to avoid injuring the young growth. The trees must, if necessary, be lopped before felling, and they must be thrown in that direction in which they are likely to do least damage. Fellings should not be made during frost unless deep snow is on the ground, as the young growth is then most brittle. The material must be taken<sup>a</sup> out of the wood by means which cause a minimum of damage, and, if possible, before the next growing season commences.

If, after the removal of the last shelter-trees, blanks of appreciable extent exist, they must be artificially filled up by planting strong plants on them, and in some cases perhaps by sowings.

*d. Marking the Trees for Removal.*

What has been said above shows clearly that the success of natural regeneration by seed under a shelter-wood chiefly depends on a suitable composition of the latter during the several stages of the regeneration period; in other words, on a careful selection of the trees to be removed. This must be carried out when the effect of the removal of a portion of the trees can be best judged, namely when the wood is in leaf. In the case of evergreen species the marking can be done at any time, but in woods containing deciduous species, the marking must be done in summer or early autumn before the leaf-fall. In carrying out the marking, only a narrow strip should be taken in hand at a time, and the business should be supervised by a competent and responsible person.

## 2. *The Strip System of Natural Regeneration under Shelter-Woods.*

As already mentioned, this system is a modification of the compartment system. Instead of conducting the regeneration process uniformly over a whole wood or compartment, the area is divided into a number of

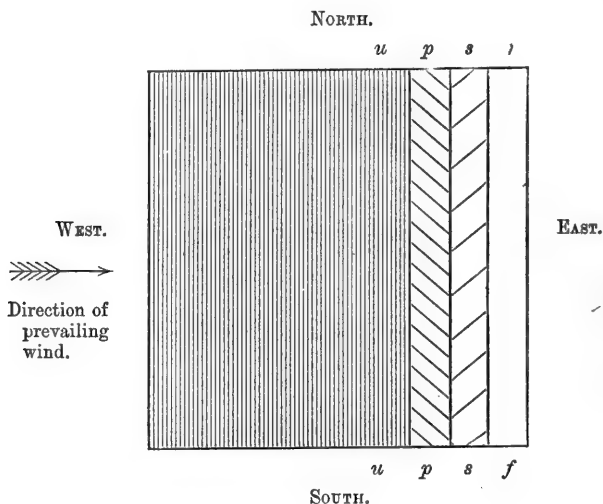

Fig. 68.

narrow strips, which are taken in hand, one by one, at such intervals, that generally three strips are under regeneration at one and the same time: one being in the final stage, one in the seeding stage, and a third in the preparatory stage. As soon as one strip has been completely regenerated a fresh strip is taken in hand, and so on until the process is gradually extended over the whole compartment or wood. In the appended Figs. 68 and 69, the strip marked *f* is in the final stage,

that marked *s* in the seeding stage, the one marked *p* in the preparatory stage, and the rest of the area marked *u* is forest as yet untouched. The process of regeneration in each strip is the same as that described in the case of the compartment system; there are the three stages one following the other.

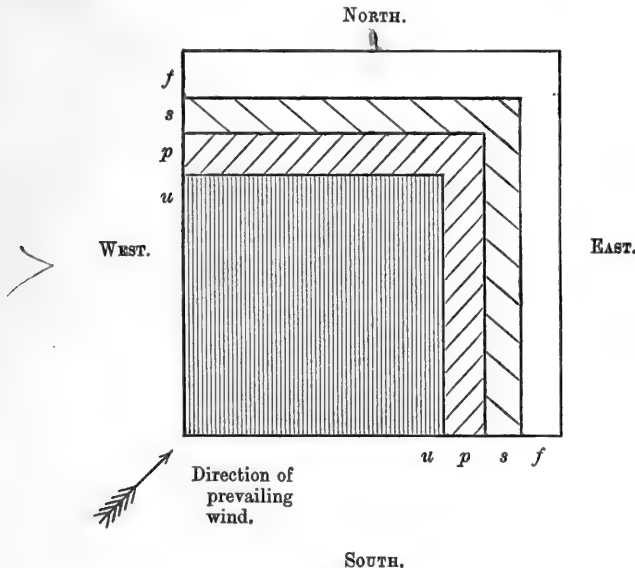

Fig. 69.

Nothing definite can be said regarding the breadth of the strips; it depends on the species and the local conditions. Those who advocate the system say that, ordinarily, the breadth should not exceed the height of the trees. There is no limit to the length of the strips.

The operation should generally commence on that side of the wood which is opposite to the prevailing wind direction; this rule may be overridden by other considerations, for instance an unfavourable distribution

of the age classes. In some cases the wood may be, if necessary, attacked in two or more places at the same time.

For the rest, little or no difference exists between this and the compartment system, except that the area under regeneration is less concentrated in the former.

### 3. *The Group System of Natural Regeneration under Shelter-Woods.*

If a forest is naturally regenerated under the compartment system it may happen that, after the seed cutting, the area is not, or is only partially, stocked with a new crop. A second seed year must then be awaited, and in the meantime, the cover having been thinned, the soil may suffer considerably under the additional admission of light, so that it may not present a fit germinating bed when the second seed year arrives. Extensive working of the soil or artificial formation has then to step in. With the view of reducing this calamity to a minimum, foresters hit upon the idea of only taking in hand certain limited groups, scattered over the compartment, in the first place; when these have been successfully regenerated, they proceed with a second set of groups, and so on, until the whole compartment has passed through the process of regeneration. So far the system would after all only present a modification of the compartment system; in fact a division of each compartment into a series of minute sub-compartments (Fig. 70).

In practice, however, the system has been further modified: certain groups, as before, are taken first



in hand, and when these have been regenerated, they are gradually enlarged by regenerating successive narrow bands around them, and this process is continued until the several groups merge into each other (Fig. 71). The time required for the completion of the process in

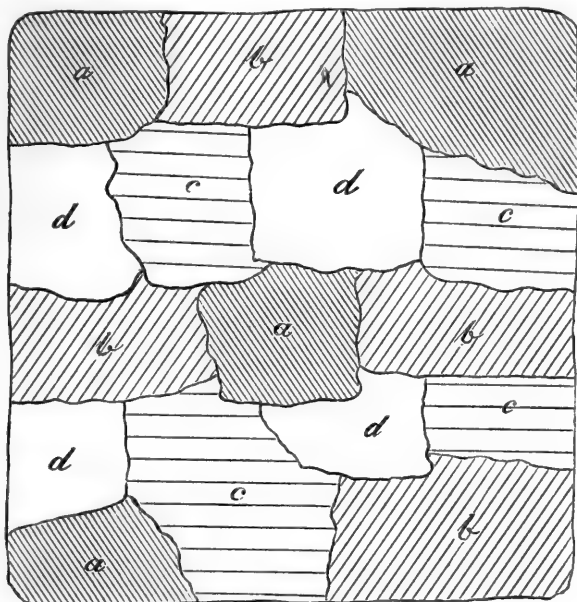

Fig. 70.

*a, a, a, a.* Groups regenerated first.      *c, c, c, c.* Groups regenerated third.  
*b, b, b, b.*      „      „      second.      *d, d, d, d.*      „      „      fourth.

each wood, or compartment, is considerably longer than under the compartment system, and it extends generally over a period of 20 to 50 years, according to species and local conditions.

A wood, while being regenerated under this system, presents a varying picture; some parts of it have been completely regenerated, others are more or less advanced in the process, and others again are as yet untouched,

with a complete and uninterrupted cover overhead. When the whole process has been completed the young wood consists of trees varying in age by 20 to 50 years,

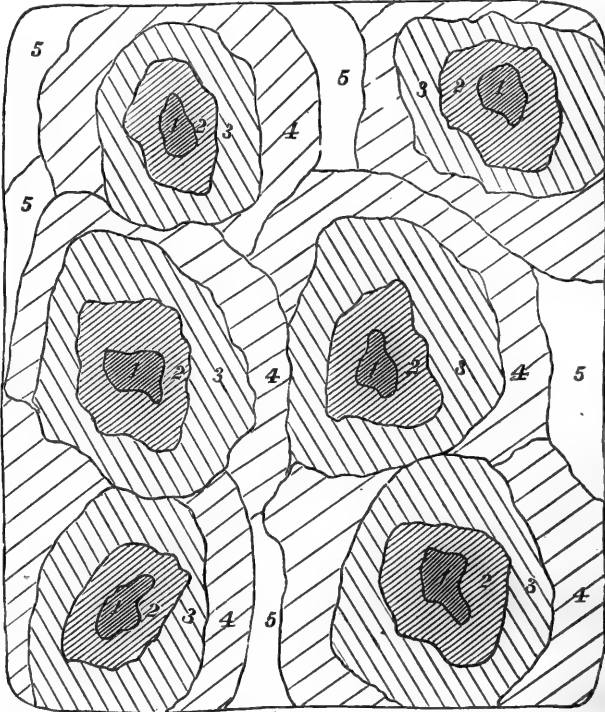

Fig. 71.

- |          |  |
|----------|--|
| 1, 1, 1. | Points of attack (groups of advance growth). |
| 2, 2, 2. | } Successive enlargements of groups.         |
| 3, 3, 3. |  |
| 4, 4, 4. |  |
| 5, 5, 5. |  |

according to circumstances; it is in fact an uneven-aged wood.

*a. Selection of Groups.*

The time when the different parts of the wood are attacked depends chiefly on the following considerations:—

## i. ADVANCE GROWTH.

In almost every mature wood groups of young growth are found, which have sprung up here and there before the regeneration cuttings have been commenced; such young growth is called "*advance growth.*" Under the compartment system it is not much valued, partly because it gives the young crop an uneven character, and partly because, having stood for some time under the shade of the whole wood, it is not always capable of developing into healthy full-sized trees; hence it is frequently removed altogether to make room for a uniform new crop. Under the group system all patches of advance growth, which are still healthy and capable of developing into full-sized trees, are carefully husbanded. They form the nuclei of the first regeneration groups; the old trees standing over them are removed when no longer required, then the groups are enlarged, as indicated above, by gradually cutting away the immediately adjoining trees in narrow bands.

## ii. DIFFERENCES OF AGE, GROWTH, COVER, AND SPECIES.

Many old woods are naturally of uneven age. In such cases the oldest parts are first taken in hand, followed by the next age gradation, and so on.

Again, certain parts have from one reason or another not kept pace in development with the rest, nor are they likely to make up for it. They should be taken in hand first, so as to avoid loss of increment.

Frequently certain parts have thinned out naturally, followed by an interruption of the leaf canopy; they must be attacked first of all.

In mixed woods, groups of different species may require regeneration at different times, offering an additional opportunity for a judicious selection of the groups to be first taken in hand.

iii. DIFFERENCES IN THE CONDITIONS OF THE LOCALITY.

These may demand different treatment. The degree of moisture, porosity and fertility may vary from place to place, according to the surface configuration, aspect, and the character of the soil, inviting a change of treatment, and an earlier or later commencement of the regeneration process.

iv. GENERALLY.

It is clear that in many woods the most suitable moment for regeneration does not occur at one and the same time over the whole area, thus offering sufficient room for a suitable selection of groups in which the process of regeneration should commence.

*b. Process of Regeneration.*

This is, in principle, the same as that described under the compartment system ; there are preparatory, seeding and final cuttings, but they are not always quite distinct, and frequently the preparatory or seeding cutting, or both, are unnecessary. Over advance growth, for instance, the two first stages are already past, and the final stage alone remains.

Frequently a seeding cutting or a final clearing in one group admits sufficient light into an adjoining one to act as a preparatory cutting for it.

Where the cover overhead is still complete and no advance growth has made its appearance, regular preparatory cuttings are made in the usual way, followed by a seeding cutting, so as to create groups of new growth which form the centres of future operations.

#### 4. *The Selection System of Natural Regeneration under Shelter-Woods.*

Under this system regeneration goes on in all parts of the forest by the removal of the oldest, largest, diseased or defective trees, wherever they are found. No part of the forest is ever at rest; advantage is taken of all seed years for the re-stocking of small holes cut into the cover here and there by the removal of one or a few trees. Of the large quantities of seed which fall annually or periodically to the ground, only a small portion finds conditions favourable for the development of young trees; the latter are found chiefly in those parts where old trees are standing, or where the cover has been interrupted. Here little groups of seedlings spring up, which must be assisted by cuttings, either final or intermediate, to afford them the necessary light. Such cuttings are the only regeneration cuttings made under the system.

Where an extensive area is treated under this system, it is frequently divided into a number of blocks, one being taken in hand every year. In this way cuttings are made in each block at regular intervals. In the Beech forests of Buckinghamshire it is usual to cut according to the selection system every 7 years; in the Teak forests of Burma every 10—30 years;

in the Buxa Sal forest in Bengal, every 40 years. It stands to reason, that in such cases, the cuttings must be heavier in proportion to the interval between every two cuttings.

5. *Comparative Merits of the four Systems of Natural Regeneration under Shelter-Woods.*

Each of these systems has certain advantages and drawbacks, which it is useful to bring out and compare. The result will be to show that under a given set of conditions any one system may be preferable to the others.

a. *The Compartment System.*

(1.) The business of regeneration is concentrated on an uninterrupted portion of the area, and it is completed within a comparatively short space of time. It follows that supervision is easier, and that it can be more complete, all other things being equal, than when the work is spread over a number of disjointed groups or strips.

(2.) The material to be removed at one time being collected within the smallest space, more satisfactory and cheaper means of export are admissible than under opposite conditions. Roads, slides, and other means of transport are of a minimum length, and their construction and annual repairs are less expensive than in the other systems.

(3.) Lateral shade is less likely to injure a young crop demanding full enjoyment of light.

(4.) Under the system a whole wood, or compartment, is treated in an uniform manner. If the cuttings have been executed at the right time and in the right

manner, the soil at the advent of the seed year being in a favourable condition for germination, and extremes of climatic conditions, such as frost or drought, not causing lasting damage, then the result of the operation is sure to be satisfactory; in other words, a healthy young crop will have been produced. If, on the other hand, such a happy coincidence of conditions should not take place, the results may be far from satisfactory. It must be remembered that, in this case success or failure extends over a considerable area, all concentrated in one place; if it is a failure, only a thin cover overhead will be left, under which the soil may deteriorate rapidly whilst a second or third seed year is awaited. In some cases the trees may be sufficiently vigorous to extend their crowns and to re-establish the cover, so that the process of regeneration may be initiated a second time and brought to a successful conclusion; but in the majority of cases this will not be possible, the soil will suffer, and artificial cultivation has to step in.

(5.) In summing up, it may be said that the compartment system is indicated in localities which are not exposed to exceptionally unfavourable climatic conditions, and which have a soil of a fairly uniform character. Where the opposite conditions prevail, the group or selection system may be preferable; at the same time it must not be overlooked, that the drawbacks of the system can be eliminated to a considerable extent by reducing the area to be dealt with at one time in one locality. The system is better adapted for the regeneration of pure than of mixed woods.

*b. The Strip System.*

The system partakes of the character of the compartment system carried out on small compartments; the danger of failure over a large continuous area is avoided, and the shelter-wood less liable to be blown down, but the operations are less concentrated.

*c. The Group System.*

(1.) The drawbacks are, that the operations are scattered over a larger area at one and the same time, rendering supervision more difficult and the transport of the material more expensive.

(2.) The principal advantages of this system over the compartment system are:—

- (a.) It insures a more complete preservation of the factors of the soil;
- (b.) It affords greater security as regards the success of the regeneration, because it is carried out on small scattered areas, so that failure in one does not imply failure in the others;
- (c.) Each group can be taken in hand when the most favourable moment for regeneration has arrived.

(3.) In summing up, it may be said that the group system is in its place where the conditions of the locality or of the crop change from place to place, or where extremes of climate prevail. It is admirably adapted for the regeneration of mixed woods, as it affords excellent opportunities for securing a proper mixture of the several species in the new crop.



*d. The Selection System.*

Here the drawbacks of the group system are further intensified, without offering sufficient compensation by way of advantages in other respects. True, the soil is still more completely protected, but this is generally accompanied by withholding from the young growth a suitable measure of light.

The system is, in Europe, confined to localities where the uninterrupted maintenance of a crop of forest trees is necessary for the protection of the soil against heavy rain, snow, wind, etc., in fact for so-called *protection forests* in high or steep mountains. It is also useful in forests of specially small or large extent; in the former, if the area is insufficient for a regular division into compartments, and if nevertheless a certain quantity of timber is required annually; in very large forests which are as yet in the first stage of systematic management, such as many of the forests in India. It is also practised, generally in a rude form, where the demand for produce is as yet much below the supply.

II. *NATURAL REGENERATION FROM ADJOINING WOODS.*

After the area has been clear cut, the seeding is effected by the seed falling from mother trees, which do not stand on the cleared area, but alongside of it.

The points which demand attention are the conditions of success and the merits of the system.

1. *Conditions of Success.**a. Sufficient Seeding of the Area.*

The agencies which carry the seed on to the area are air currents, and in some cases water, or the seed may roll by its own weight down a slope. When air currents are the carrying agency it is necessary that the seed should be sufficiently light, and that the wind should blow from the right direction when it falls. In this respect the species, the force of the air current, and the relative position of the regeneration area are of importance. The seed of some species, as Poplar, is so light that it travels for miles, while that of others falls straight to the ground. Gayer gives the following distances for a number of species under the influence of a moderate air current :—

Birch, Elm, Larch,	4—8	times	the	height	of	the	trees.
Spruce, Scotch Pine,							
Alder . . . .	3—4	”	”	”	”	”	”
Maple, Ash, Horn-							
beam . . . .	2—3	”	”	”	”	”	”
Lime, Silver Fir,	1—2	”	”	”	”	”	”
Beech and Oak,							scarcely beyond the reach of the crowns.

In the case of strong winds the distances are proportionately greater; instances can be seen in Scotland where Scotch Pine seed has been carried to many times the distance given above. The distances are also greater, if the mother trees stand at a higher elevation than the regeneration area.

The direction of the wind during the fall of the seed

introduces a great element of uncertainty, as it can only in rare cases be relied on.

A further complication may arise if the seed should fall during the prevalence of a dry east wind, while, for other reasons, regeneration should commence in the east and gradually proceed towards the west.

*b. Suitable Condition of the Germinating Bed.*

This has often to be provided by working, or wounding the soil. Where the roots of the trees are grubbed out the soil is sufficiently stirred, but where the stools remain in the ground extra working may be necessary.

*c. Security against external Dangers.*

These are chiefly frost, drought, and a growth of weeds. Some protection will be given by the adjoining wood, but the amount depends on the breadth of the area under regeneration at one time, and the relative position of the mother trees.

*d. Extent of the Clearing.*

The smaller the regeneration area is, the more satisfactory will be the results. On large areas a period of 10, 20, or more years may be required to complete the new crop, which will be very uneven, and in the majority of cases artificial sowing and planting has to step in.

The chances of success are much greater if the regeneration area has the shape of a narrow strip running along the edge of the mother trees. The

breadth of such strips should not exceed the height of the mother trees, so that they may not only be quickly and fully stocked, but in order to provide better protection for the young crop against climatic dangers; the soil keeps also fresher.

Such protection is further increased if successive clearings do not adjoin each other, but are separated by older woods. Sometimes the clearings represent patches situated in the middle of old woods. Arrangements of this kind lead, however, to a very complicated system of management; hence they occur only where groups of trees have been thrown by wind, or snow, or killed by insects. If patches are cut purposely, they often lead to the group system described above.

## 2. *Merits of the System.*

Owing to the uncertainty of the seeding and the injuries to which the young tender plants are afterwards exposed, the system can be recommended only under favourable conditions of the locality and in case of hardy quick-growing species. Damage by insects, especially the cockchafer, *Hylesinus*, and *Hylurgus* further narrows the limits of applicability.

### B. Natural Regeneration by Shoots and Suckers.

It has been explained in Volume I,\* that woody plants can reproduce themselves by means of shoots or suckers, or both. Shoots may spring from the stool, after the tree has been cut over close to the ground, or from the stem and top, if the cutting is

\* See pages 174 and 213.

restricted to the side branches and the upper part of the stem. Accordingly a distinction may be made between regeneration from the root, stool, or stem. Of these, reproduction by stool-shoots is by far the most important, but as in many cases it occurs together with reproduction by suckers, the two will be dealt with together.

### 1. *Regeneration by Stool-Shoots and Suckers.*

It has already been explained that regeneration follows the cutting over of the trees. Where stool-shoots are wanted, the cutting over takes place close to the ground, followed by a clump of shoots which spring either from adventitious buds formed on the callus near the edge of the cut, or from dormant buds on the neck of the stool. A similar mode of cutting is employed where both stool-shoots and suckers are wanted. If only the latter are desired, the stump may be removed, and only the roots left.

The success of this system of regeneration depends on many things, of which the following require special attention.

#### *a. Species.*

Of the species growing in temperate Europe only broad-leaved trees and shrubs are adapted to the method, and even amongst these great differences exist in regenerative power.\*

#### *b. Age of Wood at Time of Cutting.*

Generally, reproduction is most powerful during youth up to the period of principal height-growth, and under

\* See page 175 of Volume I.

favourable circumstances for some time beyond it. Hence the wood must be cut over for the first time at a period not beyond the end of the principal height-growth. After that, the rotation depends on the required description of material (firewood, hop-poles, bark of a certain quality, etc.), and the time up to which the stools are capable of vigorous reproduction.

The increment of coppice woods is also greatest during early youth, which is another reason for short rotations.

#### *c. Soundness of Stools.*

Diseased stools often produce diseased shoots, though some species, as Oak and Hornbeam, are usually exempted from this liability; the same holds good in the case of suckers. It follows that diseased stools should be removed and replaced by strong plants to produce fresh and sound stools.

The longevity of the stools is closely connected with their health, which is principally governed by the species and the character of the locality. A fertile soil and favourable climate increase the longevity. The stools of Ash, Maple, Birch, and also those of Beech, are short-lived, lasting frequently not longer than two or three rotations; those of Oak and Hornbeam are almost indestructible, and between these extremes many intermediate stages exist.

#### *d. Manner of Cutting.*

The cut produced by the removal of the stem is exposed to the effects of air, moisture and sun, which cause a deterioration of the wood near the cut through

drying up and rot, and tend to reduce the reproductive power of the stool.

Although this process of deterioration cannot be altogether prevented, its extent and rapidity can be reduced by careful cutting. In the first place the size of the cut should not be too large, in the second place it should be smooth, and finally it should be slanting, so that water may not rest on it (Fig. 72). In the case of large shoots, the cut may be given a slope from the centre to two sides,



*Good.*  
Fig. 72.

*Good.*  
Fig. 73.

*Bad.*  
Fig. 74.

or it may receive the shape of a cone (Fig. 73). The cut should on no account slope inwards (Fig. 74). The cut should be made with a sharp billhook or axe, and not with a saw. If the latter is unavoidable, the cut should subsequently be smoothed with a billhook, axe, or knife. Another important point is that the bark should not be severed from the wood around the edge of the cut.

The height from the ground at which the tree is cut over also influences the success. Except where inundations are feared, it is preferable to cut close to the ground, as there is less corky bark on the root-neck; besides, if the shoots appear low down, at or a little below the surface, they are more likely to develop independent roots, and thus ensure great longevity of the stool.

In southern countries, where the sun may dry up the

stools, it may be necessary to cut below the ground, or to cover up the stools with earth.

*e. Season of Cutting.*

The best season of the year for cutting is a few weeks before the buds begin to swell. Various circumstances may, however, prevent this being done, such as an insufficiency of labour, the necessity for peeling the wood, etc. Where labour is not available to do the whole cutting at the most favourable period, a part must be done (in Europe) in the autumn; this has the drawback that frost during winter frequently separates the bark from the wood of the stool, or that the stools are killed outright. Again, stools which were cut over in autumn send out shoots somewhat earlier in spring, and thus render them more liable to be touched by late frosts.

Where the principal object is to obtain bark for tanning, the cutting must be done during the full flow of the sap, that is to say, in temperate Europe, in May and the beginning of June.

*f. Standards.*

The reproduction is most complete if the wood be clear-cut; the more standards are left, the less favourable will be the crop of shoots and suckers.

*2. Reproduction by Stem-Shoots, or Pollarding.*

Pollarding consists in the removal of the crown of a tree, either leaving the main stem intact or cutting it off at a certain height from the ground; in the latter



case the system is frequently called topping. The branches may be cut off close to the main stem, or at a short distance from it, the latter method being preferable. New shoots spring from the cuts, and these are again cut after one, two, or more years, according to the desired size of the produce.

What has been said above regarding species, health of the mother trees, and manner and season of cutting, holds mostly good also as regards pollarding. The system is chiefly employed for Willows and Poplars; the former yield materials for basket work, fascines, hurdles, etc., and the latter firewood and small sticks for domestic use.

### SECTION III.—CHOICE OF METHOD OF FORMATION.

The choice of method depends on numerous considerations, such as the silvicultural system, species, soil, climate, external dangers, labour, cost, etc. To attempt a detailed exposition of these matters in reference to the several methods would not lead to any practical result, since, after all, the choice depends on the local circumstances of each case. A few remarks regarding the main groups of methods may, however, not be out of place. These main groups are :—

- (1.) Direct sowing.
- (2.) Planting.
- (3.) Natural regeneration by seed.
- (4.) Natural regeneration by shoots and suckers.

Of these the last-mentioned method refers almost entirely to coppice woods worked under a short rotation; it is not employed where woods are treated under a

high rotation, because in very rare instances only do coppice shoots reach the same size as seedling trees.

The questions which interest the Sylviculturist most are—

- (1.) Whether to sow direct or plant on cleared areas.
- (2.) Whether to regenerate existing woods artificially, or naturally by seed.
- (3.) Whether or not combinations best meet the objects of management.

These three questions, then, will be shortly discussed in the following pages.

#### **A. Choice between Direct Sowing and Planting.**

Formerly the artificial formation of woods was chiefly effected by direct sowing, planting being restricted to special cases where the other method was not likely to succeed. The reasons for this were, that sowing was considered to be more certain, cheaper, and that it was generally the custom to use too large transplants. In the course of time the raising of plants was elaborated, smaller plants were used and the expense considerably reduced, so that now far more planting than direct sowing is done. Yet it is not always a foregone conclusion that planting is better or more suitable than direct sowing, since many differing conditions and factors affect the ultimate results. The effect of some of these factors is as yet somewhat obscure, but in many respects experience has taught the forester which of the two methods is prefer-

able under a given set of conditions. The points of view from which the choice of method may be approached are manifold, and amongst these the following deserve attention :—

- (1.) Objects of management.
- (2.) Desired silvicultural system.
- (3.) Selected species.
- (4.) Conditions of locality.
- (5.) External dangers threatening the young wood.
- (6.) Quality and quantity of available labour.
- (7.) Cost.

### 1. *Objects of Management.*

The objects of management have been shortly indicated on page 99 of Volume I., and it will be readily perceived that, according to circumstances, either planting or direct sowing may more completely meet them.

Where the object is to produce trees of special beauty, few foresters would think of creating them by direct sowing; where time is an object and expense of minor importance the planting of strong transplants would be most suitable. If the object of management centres in the production of the greatest possible quantity of small material, with the least possible outlay, direct sowing would probably yield better results than planting. Again, for the production of clean timber trees sowings, with their greater density, may in many cases be more suitable than planting, unless the latter be very close and thus involve a considerable outlay.

Economy in working is one of the leading principles

in Sylviculture. In this respect either sowing or planting may be preferable, according to circumstances; experience, however, shows that where plants of good quality can be raised at a reasonable outlay, planting yields higher and more valuable returns than direct sowing, if time be considered.

Where the land is required for pasture or grass-cutting, planting is decidedly preferable, as cattle can be admitted at an earlier age, while grass-cutting can be commenced at once.

## 2. *Sylvicultural System.*

The formation of woods to be treated under the pollarding system, and of osier beds, is best effected by planting. The same may be said of ordinary coppice woods and the production of standards in coppice. In ordinary seedling forests, either method may be adopted.

## 3. *Species.*

The species affects the choice of method in various ways. In the first place many species produce seed abundantly only at irregular and often long intervals; hence continuous operations can be carried on only by planting, as the production of nursery plants requires comparatively small quantities of seed, and this, if necessary, can be obtained from a distance. By keeping a quantity of reserve plants in the nursery, seedless years may be tided over without interrupting the work.

Species, the seed of which germinates with difficulty or slowly, or the seedlings of which are tender in early youth, should be propagated by planting and not by

direct sowing. In such cases it is much easier and cheaper to provide the necessary tending and protection in a compact nursery than on an extensive forest block.

Species which grow slowly during youth, should be planted; those of fast and early development may be sown direct, if this be desirable on other grounds.

The shape of the root-system is also of importance. Species which develop a compact and comparatively shallow root-system are much easier to plant than those which at once develop a deep-going tap root; for the latter, direct sowing may be advisable. Long tap roots may, however, be pruned, or the seedlings raised in such a manner that they are forced to develop a compact root-system; at the same time either alternative may be of doubtful expediency.

Mixed woods should be established by planting, as a proper mixture of the species is rarely practicable by direct sowing; at any rate some of the species must be planted. Frequently it is desirable to give one species a start over another, and this can be done in a satisfactory manner by the use of large plants.

#### 4. *Condition of Locality.*

As a general rule it may be said that planting is preferable whenever the conditions of the locality are unfavourable, especially where extremes of soil and climate prevail, while in a favourable locality direct sowing may yield equally good results.

Unfavourable localities are those with a wet, occasionally inundated, or very moist, heavy, cold soil;

excessively loose, dry, or poor soils; those subject to be overrun by a heavy growth of weeds, or where frost-lifting may be expected. Similarly, planting is far preferable to direct sowing where extremes of climate prevail, such as in raw, frosty, exposed localities.

On steep slopes planting is also preferable, but in very stony soil direct sowing may become a necessity.

### 5. *External Dangers.*

Seeds, as well as young seedlings, are subject to attacks by various animals, against which they can be more effectually protected in a nursery than in the forest; hence, on this account, planting is preferable to direct sowing. As regards attacks by insects, it is an open question which of the two methods is preferable. As long as only thoroughly healthy plants are used and put out with care, they may hold their own and even do better than seedlings in direct sowings; but weak plants, or those which have difficulty in establishing themselves quickly in their new home, are more subject to attacks by insects than seedlings grown *in situ*. The same often holds good as regards attacks by fungi.

### 6. *Labour.*

Unless direct sowings necessitate a thorough working of the soil, they require less labour than planting. Where labour is scarce direct sowing may, therefore, prove to be cheaper. Planting also requires better skilled labour than direct sowing.

7. *Cost.*

Whether direct sowing or planting is the cheaper method depends on the price of seed, the extent to which the soil has to be worked for direct sowings, and the cost of plants. Direct sowing is generally cheaper, but if seed is expensive and small plants can be utilized, planting may be the less costly method of the two.

**B. Choice between Artificial Regeneration, and Natural Regeneration by Seed.**

Sowing and planting can be done under the shelter of the old wood, or it can follow a clear cutting; natural regeneration can be done under a shelter-wood, or on cleared areas of moderate breadth by seed coming from an adjoining wood. The differences between the two shelter-wood methods are small, while they are considerable between the clear-cutting and shelter-wood methods. The following remarks refer chiefly to the latter case.

1. *Merits of Artificial Regeneration.**a. Advantages.*

(1.) Artificial regeneration is independent of the local occurrence of seed years, since sufficient seed for nurseries, and frequently also for direct sowing, can always be obtained from a distance. This being so, the adoption of the method enables the forester to proceed in a systematic and regular manner, doing the desired quantity of regeneration year after year, and providing the market with a steady supply of produce.

(2.) The full enjoyment of light can at once be secured to young trees which are light-demanding and hardy.

(3.) The trees develop more rapidly than those originating by natural regeneration, at any rate up to middle age.

*b. Disadvantages.*

(1.) Sowing and planting are costly. The outlay on the latter can, however, be considerably reduced by planting small plants according to a simple and cheap method.

(2.) Where artificial regeneration follows clear-cutting, the young plants are exposed to damage by frost, drought, insects and weeds in a far higher degree than if the regeneration is conducted under a shelter-wood. In fact, tender species must be raised in the latter way, so that for them clear-cutting is excluded. Insects frequently become formidable to coniferous woods raised in clear-cuttings, while experience has shown them to be less dangerous to natural seedlings, especially when these are raised under a shelter-wood.

(3.) In the case of clear-cuttings, the laying bare of the ground for a series of years may seriously affect the fertility of the soil, so much so that the method is hardly admissible on inferior soils.

*2. Merits of Natural Regeneration by Seed.*

*a. Advantages.*

(1.) Natural regeneration involves less expenditure than sowing or planting. In some cases the outlay may be absolutely *nil*, but in most cases some artificial help has to be given either by working (wounding) the soil,



or by sowing and planting. Still the outlay is considerably smaller. It must, however, not be overlooked that in the majority of cases natural regeneration requires much time; as long as the shelter trees increase sufficiently in size and quality so as to make up for any loss on this account no harm is done, but where this is not the case artificial regeneration may be actually more profitable.

(2.) Damage by frost, drought, and weed growth is avoided, or at any rate considerably reduced. The same may be said as regards damage by insects, though perhaps not to an equal extent.

(3.) The activity of the soil is maintained, and, to a considerable extent, rendered independent of climatic influences.

(4.) Owing to the greater number of plants per unit of area, clearer and straighter stems are produced than in plantings, and also frequently in sowings, though the difference in the latter case is less decided. This advantage can to a considerable extent be nullified by dense planting and sowing, but in that case the cost is proportionately increased.

#### *b. Disadvantages.*

(1.) The method is more complicated and difficult than artificial regeneration; hence it demands more skilful foresters.

(2.) The intermittent nature of seed years produces many drawbacks as regards the equalisation of the yield and the control of operations.

(3.) The removal of produce is also more expensive.

### 3. *Summing up.*

Neither the artificial nor the natural method of regeneration is the best at all times and under any circumstances ; only a consideration of the local conditions can lead to a sound decision as to which is preferable in a given case. In forming such a decision the forester must chiefly take the following points into consideration :—

- (a.) General objects of management.
- (b.) Species to be grown.
- (c.) Condition of locality.
- (d.) Available funds.
- (e.) Skill and capacity of the staff.

#### **C. Combination of Several Methods of Formation.**

In the preceding two sections the various artificial and natural methods of forming a wood have been described. Each of these methods has special advantages under certain conditions, and as the latter may and frequently do vary within a narrow extent of area, it follows that two or even more methods may be employed in the formation of a wood, thus securing greater success and frequently a reduction of expenditure. In fact, in practical Sylviculture such combinations are the rule and not the exception.

Of the combinations here indicated the following are of special interest :—

1. *Combination of Artificial Formation, and Natural Regeneration by Seed.*

Natural regeneration assists artificial formation only in rare cases, but the reverse constantly happens. Rarely are natural regenerations by seed so complete that they do not require artificial help, which can be afforded by sowing or planting, generally the latter. There are always certain parts of the regeneration area which, for one reason or another, do not become stocked and have to be planted. up. Then it frequently happens that the ruling species shall be mixed with others which must be brought in artificially, or one of the species in a mixed wood fails to produce seed for a considerable period, while the other, having regenerated itself, demands the removal of the mother tree.

In many cases, it can be foreseen that certain portions of an area are unfit for natural regeneration; these may at once be artificially stocked, even before the natural regeneration of the remainder has commenced. In other cases a part of the area may have been deprived of the necessary shelter trees by natural phenomena; here artificial shelter woods may have to be planted.

From the above remarks it will be seen that artificial and natural formation may be started at the same time, or the one may precede the other. In all such cases, blanks in existing woods should be filled up with strong plants of a quick-growing species.

2. *Combination of Artificial Formation with Regeneration by Stool-Shoots or Suckers.*

This combination occurs constantly in coppice woods, where stools, which have died or become diseased, are replaced artificially by putting in strong plants or slips, and in some cases by sowing seed, such as acorns or chestnuts. Only in rare cases are such stools replaced by natural seedlings.

3. *Combination of Natural Regeneration by Seed with Regeneration by Stool-Shoots and Suckers.*

This case may occur in high forest, where the seedling trees have been injured by frost, game, cattle, mice, hail, &c.; it may then be advisable to cut them back in order to get strong healthy shoots.

The combination occurs further in coppice with standards. Here it is desirable that the standards should be seedling trees, and their regeneration may be effected by the seed falling naturally on the ground.

4. *Combination of Artificial Formation with Natural Regeneration by Seed and by Shoots.*

It occurs in coppice with standards, when a sufficient number of the latter cannot be obtained by natural regeneration.

SECTION IV.—FORMATION OF MIXED WOODS.

The various methods of forming a wood described in the previous sections of this chapter are applic-

able to both pure and mixed woods. There are, however, certain peculiarities in the formation of mixed woods which it will be necessary to indicate. As the number of possible mixtures is very large, a separate reference to each is impossible. It must suffice to deal with them in the following groups:—

(1.) Formation of even-aged woods, or in which the ages of the species in mixture differ so little that they may, for practical purposes, be considered as even-aged.

(2.) Formation of mixed woods consisting of trees of uneven age, such as high forest with standards, two-storied high forest, &c.

### 1. *Formation of Even-aged Mixed Woods.*

In Chapter III. of Volume I. (page 179), it has been explained that in order to preserve mixtures in which the species are of the same age, the latter should show nearly the same rate of height-growth throughout life. Whenever this is not the case, any species sensitive to cover and likely to be outgrown by associated species must be given a start, while the latter must be capable of bearing the shade of the former. In the absence of these conditions the species must be separated, and the utmost which can be done is to place them in alternating groups. Even then there is no certainty that in regenerating such a wood the new crop will show the desired mixture. At any rate it will be clear that the regeneration of such woods requires constant attention, lest one species should oust another.

*a. Sowing and Planting in Clear-Cuttings.*

Sowing can be done by mixing the seed of two or more species, or by sowing one over the other, either direct or crosswise. The second method must be followed whenever the seeds require a different covering, that which requires the deeper one being sown first. Another method is to sow in alternate strips. Such sowings are rarely made now-a-days, but recourse is had to planting, as it permits the mixture being arranged in any way which may be desired. The species may alternate in single plants, or in lines, or strip- or group-wise. Again the proportion of one species to another can be absolutely fixed. The group system is specially indicated where the conditions of the soil change from place to place, as each patch can receive the most suitable species. The size of such groups depends on circumstances; if it exceed a certain limit, the wood can no longer be considered mixed—it becomes a series of pure woods.

Where a light-demanding species is to be mixed with a shade-bearer, the former can be given a start of a few years, instead of arranging the mixture by groups. In such cases the mixture is frequently arranged by lines, the light-demanding (and generally hardy) species being planted first in alternate lines, and the shade-bearing species (generally tender in early youth) afterwards in the intermediate lines.

Another way of giving one species a start over another is to put in plants of different ages.

In many cases one species is raised with field crops, while the other is planted in, when the cultivation of the field crops has ceased.

Formerly it sometimes happened that one species was raised by sowing and the other by planting, but this is rarely done now-a-days.

*b. Sowing and Planting under Shelter-woods.*

This method is followed in the case of species which are tender during youth, especially in respect of frost.

If an old wood exists, and a new mixed wood, consisting of a tender and a hardy species, is to be created, the former may be sown or planted alone under the shelter-wood; then when the shelter-wood is no longer required, it is removed, and the second hardy species planted in. This method is followed, for instance, where Beech is to be mixed with Scotch Pine or Larch.

If no old shelter-wood is available, then the hardy species is cultivated first, and when it has advanced sufficiently to provide the necessary shelter, the tender species is introduced. In this way Scotch Pine, Larch and Birch are planted to serve as shelter woods (nurses) for Beech, Silver Fir, Ash, Oak, and Spruce.

*c. Natural Regeneration under Shelter-woods.*

In regenerating a mixed wood, it is of first importance that the shelter-wood should be composed of trees of the several species in such proportion as to secure the desired mixture in the new crop. In determining that proportion, the relative reproductive power of the species must be taken into consideration; more especially the size and quantity of the seeds, the frequency of seed years, the height-growth of the species in early youth,

and its capacity of bearing cover ; its degree of hardiness, the nature of the germinating bed, &c.

Already during the last thinnings the cuttings can be so arranged as to lead to a proper proportion of the mother trees. This process is continued and if possible completed during the preparatory stage. Under any circumstances it must be completed by the seeding cutting.

In many cases a great difficulty arises from the fact that the several species do not seed in the same year. In such cases the seeding cutting must be made, when that species seeds which is to form the bulk of the new crop, or which is the more difficult to rear ; the other species, if they have not produced a sufficient proportion of seedlings beforehand, or fail to do so within a few years afterwards, must receive artificial assistance.

The arrangement of the cuttings during the final stage depends on the requirements of the new crop in the several parts of the wood. Where conflicting interests present themselves, those of greater importance must prevail.

The trees to be left for the final cutting should belong to the most wind-firm species, to that which is most likely to increase rapidly in size and value, and if possible to one with a thin crown.

The above remarks show that it is in many cases a difficult task to guide successfully the process of regeneration in a mixed wood ; hence a method should be chosen which reduces the difficulties to a minimum. With this end in view the several species may be brought together in small groups, each of which can be treated in a manner best adapted to the particular



species. If this should be found insufficient, the following method must be adopted:—

*d. Natural Regeneration combined with Sowing and Planting.*

Natural regeneration alone rarely leads to the desired result; only parts are successfully stocked, and sowing and planting must step in to complete the business. In applying this method it must be remembered that generally the more favourable parts of the area become naturally stocked, leaving the inferior spots blank. If only the latter were filled up by sowing or planting the species which is deficient in the naturally regenerated patches, it would be relegated to the bad spots, while the other species would occupy the better parts; hence it is also necessary to plant a proper number of the artificially reproduced species within the patches already naturally regenerated.

This method is in Europe much used in the formation of mixed woods of Beech with Oak, Ash and other valuable timber trees. In fact it is the best method for such mixtures. The valuable species are generally introduced by putting in strong plants; sowings are comparatively rare, and only admissible in the case of shade-bearing species.

*2. Formation of Mixed Woods of Uneven Age.*

It has been shown that the preservation of the mixture is difficult, when the trees are of the same age, or nearly so, and that it requires constant care and attention, lest one species should be suppressed by

another and disappear. Such unremitting attention cannot always be given, apart from the expense which it involves. Endeavours have, therefore, been made to devise a method of mixing species which is less dependent on constant attention, and this has been found in giving to the mixed species a greater difference of age. Such an arrangement causes a considerable difference in the ages of the component parts of the wood. Each of these requires to be regenerated at its own time, so that the process of regeneration is gone through several times in the course of one rotation, one part of the wood being regenerated on each occasion.

Many varieties of mixed woods of uneven age have been evolved, each of which corresponds, more or less, with a distinct sylvicultural system. Of these the following claim attention :—

- (a.) The group and selection systems.
- (b.) High forest with standards.
- (c.) Two-storied high forest.
- (d.) Mixed coppice with standards.

*a. The Group and Selection Systems.*

Under the group system the regeneration of a wood extends over a period ranging up to 40 and even 50 years. By first taking in hand the groups consisting of the threatened species, they can be given a start of 30 to 40 years. After these have been regenerated, the groups consisting of the threatening species are taken in hand. Taking, for instance, a mixture of light-demanding and shade-bearing species, such as Oak, Larch, or Scotch Pine, with Beech, Silver Fir or Spruce,

operations commence with the groups of the former, and are brought to a close by a regeneration of the latter.

Again, in a mixture of shade-bearers only, such as Beech, Silver Fir and Spruce, the last mentioned is likely to outgrow the Beech and also the Silver Fir; hence a sufficient number of groups of Beech and Silver Fir are first established, and then the groups of the Spruce.

In the case of selection forests the differences in age are still greater, and much can be done on the lines indicated above, to protect the threatened against the threatening species.

#### *b. High Forest with Standards.*

If such woods are mixed, the threatened species are selected for standards, if otherwise suitable for the purpose; it is essential that the rotation should not be very high, otherwise the future standards may suffer before the end of the first rotation has been reached.

#### *c. Two-storied High Forest.*

It has been explained in Volume I., page 220, that when a high forest has run through part of the normal rotation, a portion of the trees are removed, and a new crop is introduced, which grows up between the trees remaining of the first crop, the two being allowed to run through an additional whole rotation. The difference between the two crops ranges from 20 to 60 years. Here then is an excellent opportunity of protecting a threatened against a threatening species, the first crop consisting of the former, and the second of the latter. In Europe the

system is much adopted for the production of large-sized Oak, Larch and Scotch Pine, also Ash, Maple and others, which at a certain age are underplanted with Beech, Silver Fir, Spruce, Hornbeam, Sweet Chestnut and Hazel. This underplanting had best be done in the case of Larch at the age of 20 to 30 years, of Scotch Pine at 30 to 50 years, and of Oak at 40 to 60 years or even later.

*d. Mixed Coppice with Standards.*

This system offers, in the regeneration of the over-wood, the greatest latitude for the protection of threatened species, whether in single trees or in groups. Although some of the standards may regenerate themselves naturally, the greater part are produced by planting strong plants where mature standards have been removed.

## CHAPTER III.

## TENDING OF WOODS.

WHEN a wood has once been established it will, if left undisturbed by outside influences, grow on and reach maturity. The individual trees will, however, enter upon a lively struggle for existence, and the ultimate results will, in the majority of cases, only to a limited extent meet the objects for which the wood has been established. Moreover, external injurious effects will make themselves felt, and further reduce the returns. In order to realize those objects more fully, especially where a certain class of timber is desired, the growing wood requires well-directed tending from its formation up to the time when it is finally cut over. Care must be taken that the most favourable conditions for growth are secured, and that the development of the individual trees is so guided as to produce the desired results; in other words, the forester must take measures to preserve the continued activity of the locality, and to see that the wood has throughout its life a suitable composition. The subject divides itself naturally into the following two sections:—

- (1.) Preservation of the factors of the soil.
- (2.) Tending the crop or growing wood.

It is not, however, intended to enter here in detail upon all the matters which contribute to, or interfere

with, the desired result. The effects of the locality upon forest vegetation, and *vice versá*, have been dealt with in Chapter I. of Volume I. of this Manual, while the protection of the soil and growing wood against injurious influences will be dealt with in a subsequent volume on Forest Protection. In this place the important points will only be shortly indicated, with special reference to the sylvicultural aspect of the subject.

In order that a crop may be fully productive, it is necessary to establish and then to preserve those physical and chemical conditions of the soil on which a healthy and vigorous growth depends. The means adopted in agriculture for this purpose are working the soil and manuring. Both are expensive, and in Sylviculture they are only feasible in cases where the increased returns at least cover the outlay; they are therefore either out of the question or can only be employed to a very limited extent, and the forester must endeavour to accomplish what is needful by other means. Fortunately timber trees are far less exacting than field crops, so that the more modest means at the disposal of the forester suffice for their healthy development.

It has been shown on page 137 of Volume I., that the productive power of the soil in Sylviculture depends on:—

- (1.) A sufficient depth;
- (2.) A suitable degree of porosity;
- (3.) „ „ „ „ moisture;
- (4.) „ „ „ „ chemical composition.

For sylvicultural purposes these conditions can be

procured to a sufficient extent by the following simple agencies:—

- (a.) The preservation of a suitable cover overhead ;
- (b.) The preservation of the natural covering of the soil, more especially of humus.

How these affect the soil has been described on page 145 of Volume I. The principal fact is that the activity of the soil and a healthy development of the crop growing on it are intimately connected with each other, and that one exercises a healthful effect upon the other. At the same time the requirements of the one may be opposed to that of the other, and it must be a leading principle that the tending of the crop should always take into consideration a proper preservation of the fertility of the soil.

The above remarks refer to the case of woods which are fully stocked ; in other words, crowded woods. Cases may occur, however, where it is desirable to interrupt the leaf-canopy at a certain age to form open woods ; in such cases separate steps must be taken to preserve the fertility of the soil.

Again, during the first part of the life of a wood it is subject to special dangers, most of which disappear later on, when the attention of the forester must be directed to other matters.

The subject may, therefore, be divided into the following three sections:—

- I. Tending of woods during early youth ;
- II. „ of crowded woods after early youth ;
- III. „ of open „ „ „ „

## SECTION I.—TENDING OF WOODS DURING EARLY YOUTH.

Young woods require special protection against external dangers until they can shift for themselves; they must be kept clean, and a proper density or composition of the crop be preserved. Accordingly the subject will be divided into four groups.

1. *Protection against External Dangers.*

The details of this subject will be found under Forest Protection. For the present purpose the following notes will suffice.

*a. Fire.*

Although woods require protection against fire at all periods of their life, it is specially necessary during early youth. Protection is afforded by removing all inflammable matter, or clearing fire-traces around the area and at suitable intervals in the interior.

In addition, the area must be watched, so that any fires which occur may be promptly extinguished.

*b. Frost and Drought.*

Where regeneration takes place, whether naturally or artificially, under a shelter-wood, the latter provides the necessary protection against frost and drought, or, at any rate, insures a considerable reduction of the danger in either case. In cultivating cleared areas, shelter for tender species must be artificially provided, by growing



simultaneously or beforehand a special shelter-wood, or nurses. The trees selected for this purpose must be frost-hardy and possess a thin, or moderately dense crown. The best nurses in temperate Europe are Birch, Scotch Pine, and Larch. Where danger from late frost is excessive, Larch, owing to its early sprouting, is less well adapted as a nurse, but it does very well in all other localities. In moist localities Alder and Willows have been similarly used.

The nurses may be distributed evenly over the area, or be placed in alternate lines. They are removed when the tender species can do without them. Frequently some of the nurses are retained so as to form a mixed wood.

#### *c. Cold Winds.*

The effects of raw cold winds are often more disastrous than frost produced locally by radiation. Where they are to be feared, lateral as well as vertical shelter is required. This may be given either by adjoining woods of sufficient height and density, or, in their absence, by artificial shelter-belts, or wind-breaks. These must be dense, and they should be established some time before the area to be protected is placed under cultivation or regeneration. The species of which wind-breaks consist should, if possible, be evergreen, and with dense crowns coming close to the ground, such as Spruce.

An alternative measure consists in mixing a hardy species, such as Scotch Pine, with a tender crop. Or the wood is treated under the selection system, when trees of all ages are intermixed on the same area. In that case, the middle-aged and younger trees provide

lateral shelter for the young growth, while the old trees give vertical shelter.

In all these cases it is essential that the edges of the wood towards the side whence cold winds blow should always be kept as dense as possible.

What has been said above applies not only to frost, but also to drought, more especially in tropical climates, where hot, dry winds may be even more disastrous than cold winds are in higher latitudes.

#### *d. Weeds.*

In the case of the shelter-wood systems, under regular and successful management, noxious weeds are kept sufficiently in check to enable the young tree-growth to make its way up through them. If this is not the case, and in the cultivation of cleared areas, noxious weeds must be removed wherever they threaten to choke the young plants, until the latter have reached a sufficient height to hold their own. Heather, Broom, Brambles, climbing plants, etc., may become even more dangerous than ordinary grasses and weeds.

In considering the degree to which noxious plants require to be cleared away, it must be remembered that in moderation they may act beneficially, by sheltering the very young trees; hence interference is not called for until they actually threaten tree growth.

#### *e. Insects and Fungi.*

These form standing dangers to woods throughout life, especially where coniferous trees are grown over extensive areas. The measures which should be adopted

to protect forests against them are taught in Forest Protection. Several species of both insects and fungi are specially dangerous to young forest plants; hence it is the duty of the forester to watch carefully his regeneration areas, and to remove and destroy all plants as soon as they are attacked, and even sickly plants, so as to prevent the spreading of the evil. In many cases it is necessary to let areas lie fallow for a few years, until species, which breed in the stools and the refuse of the old wood, have disappeared again. As an illustration, *Hyllobius abietis*, the pine weevil, may be mentioned, which frequently becomes disastrous to young Scotch Pine and Spruce woods.

## 2. *Preservation of a proper Density of the Crop.*

In the majority of cases it occurs that, for one reason or another, some of the plants fail, thus causing smaller or greater blanks. All these must be filled up without loss of time. As long as the young crop is only a few years old, recruiting can be done with plants of the same kind as the original crop. Such plants may be obtained from nurseries, or, in the case of natural regeneration, they may be taken from places where the plants stand too close together. Direct sowing is also done, but planting with strong plants is preferable, because these have a better chance of keeping pace with the rest of the crop.

If the original crop is already so far advanced that plants of the same species are not likely to catch it up, the recruiting must be done with a quicker-growing species; if this is not feasible, with a shade-bearing

species likely to stand the shade of the surrounding saplings.

Sometimes a young crop of a valuable species may be too thin throughout the area, so that the soil is exposed, and the young trees are not sufficiently forced up. In such cases it may be useful to interplant the whole area with a quick-growing species, such as Birch, Scotch Pine, or Larch, which remains until the first species has grown sufficiently to form by itself a complete leaf-canopy. Frequently a portion of the filling species is retained as a permanent constituent of the crop.

Young woods which are the result of direct sowing or of natural regeneration, are frequently here and there too densely stocked. If no action were taken, the young trees would grow up too weedy and lanky; hence some of them must be pulled up. Where they are not to be used for planting elsewhere, they may be cut off close to the ground with a knife, sickle, billhook, or shears. If the plants have already reached some size, the removal of a portion must be done gradually, else the remaining plants may be bent over from being deprived of the support of their neighbours.

### 3. *Cleaning of Young Woods.*

The cleaning of a young wood has for its object to remove in good time all growth which interferes with the proper development of the principal species or individuals. Such interfering growth may consist of stool shoots amongst a sufficient number of seedling trees; mis-shapen or spreading young trees; trees which have accidentally established themselves by seed blown

on to the area (as Poplars, Willows, Birch), or carried there by animals, as Sweet Chestnut, Oak, Hazel, and others. Often Spruce, Scotch Pine, Lime, Alder, and Elm also appear where their cultivation was not intended.

It would, however, be a mistake to remove all such additions without distinction. Frequently they are very welcome in filling up otherwise thin woods; hence they should only be removed where they interfere with the principal, species or individuals.

It is often desirable to make several cleanings, especially where the undesirable growth occupies a considerable portion of the area, and where its removal at one time would leave blanks. In some cases it may even be judicious to accept a portion of the accidental growth as a constituent of the final crop, in others it may serve as a shelter wood.

#### 4. *Preservation of a proper Mixture.*

This difficult subject must receive special attention while a wood is young; much can be done towards realizing it during the operations of recruiting and cleaning which have just been described, by planting into blanks those species which are otherwise deficient in number, or by removing an excess in other places.

Again, where one species is threatened by another, the latter can be checked either by lopping off its side branches, by topping, ringing, or removing some of the trees.

The operation demands the forester's special attention, since it is much easier to produce a proper mixture at this early period of life than later on.

## SECTION II.—TENDING OF CROWDED WOODS AFTER EARLY YOUTH.

When the trees, which compose a wood have become sufficiently large to close up and form a complete leaf-canopy, several sources of injury disappear. Weed growth has ceased to affect the trees, and dangers from frost and drought have been reduced to a minimum. Danger from fire is not so acute as during the early period of life, and in a temperate climate it may disappear altogether, especially with broad-leaved species. On the other hand, danger from insects and fungi continues, while strong winds, snow and rime may break or throw down trees; such damage may extend over considerable areas.

While the forester may thus be relieved of some cares peculiar to infancy, his woods require tending in other and very important directions. He must now direct his attention more particularly to giving to each tree that growing space best suited to its further development, without sacrificing the full activity of the soil; he must also take measures to insure a high technical utility to the material under production.

The principal sylvicultural measures by which justice is done to the above-mentioned requirements may be arranged under the following three headings:—

- A. Removal of dead, injured or otherwise undesirable trees.
- B. Pruning.
- C. Thinning.

**A. Removal of Dead, Injured, or otherwise Undesirable Trees.**

In every wood single trees or groups of trees sicken or die from a variety of causes. Amongst these may be mentioned an unfavourable soil, frost, drought, fire, hail, lightning, injuries to the crown, stem or roots, attacks by insects or parasitic fungi. Again, the crowns and stems of trees may be broken by strong winds, snow and rime, or single trees and whole groups may be thrown down. From one or the other of these causes, there will always be found a certain quantity of material which, if not removed as speedily as possible, will stimulate the increase of injurious insects and of fungi. The latter have of late years been recognized as the cause of considerable damage to woods, since modern botanists have explained many important phenomena formerly imperfectly understood as to their origin. In this respect attention is invited to the ravages of *Trametes radiciperda* and *Agaricus melleus* in Scotch Pine and Spruce woods; of *Trametes Pini*, *Peridermium Pini* in Scotch Pine woods (so-called foxy trees); *Peziza Willkommii*, the Larch cancer fungus; *Æcidium elatinum*, the Silver Fir cancer fungus, the various species of *Polyporus* on broad-leaved and coniferous trees, &c.

Far greater, however, than the danger from fungi, is that from insects. Many species of the latter are apt to become disastrous to whole woods, extending over large areas.

Most of these find suitable conditions for multiplying in the presence of dead and dying trees, refuse wood, stumps, &c. Hence it is advisable that all such material should be removed as speedily as possible.

Where regular thinnings, presently to be prescribed, are carried out, all dead and dying trees are removed at the same time. Such thinnings occur only at certain intervals, and as it would be detrimental in many cases to leave the dead material in the forest until the next thinning comes round, it is frequently necessary to make special cuttings for the purpose of removing it; these are called "*dry wood cuttings*" or "*cleaning cuttings*." In carrying these out, all valuable material should be used or sold, and the refuse, if possible, burned under supervision. If danger from insects be imminent, it may be necessary to remove the stumps of trees as well, or at any rate to cover them with earth.

## B. Pruning.

### 1. *Objects of Pruning.*

Where the object of management centres in the production of valuable timber, in other words of trees with long clean boles, it is necessary for them to lose their side branches up to a certain height from the ground. Trees which grow up in crowded woods lose their lower branches naturally, owing to the insufficiency of light, and this process proceeds up the stem with the elevation of the leaf canopy from the ground. A great difference exists, however, in this respect between the various species of forest trees. Broadly speaking it may be said that, the rapidity with which trees lose their lower branches, in crowded woods, is inversely proportional to



their power to bear shade. Hence, light-demanding trees will lose their lower branches quicker than shade-bearers. In some cases the dead branches drop quickly to the ground, and in others they remain for years producing knots and irregularity in the timber laid on in the meantime. Trees grown in the open retain their lower branches more or less throughout life, and they produce in consequence timber of inferior value as compared with trees grown in crowded woods.

In the cases where the lower branches do not drop off naturally, they may be removed artificially, and this process is termed "Pruning." In Sylviculture the principal objects of pruning are as follows:—

- (1.) Increase in value of the pruned tree.
- (2.) Freedom of younger growth from the too great cover caused by overhanging trees.
- (3.) To stimulate the expansion of the crown in the upper part of the tree.

Branchless boles are of greater value than those with branches, because the timber splits better, and the scantlings sawn out of them have fewer knots. In order to realize these advantages, pruning may be extended to the removal of dead branches, or to that of green ones as well. Pruning may exercise an additional advantage in causing the bole to grow more cylindrically, instead of approaching the shape of a cone; in other words it may render boles less "tapering."

The second of the above-mentioned cases occurs where a wood consists of two or more generations of different ages, as in coppice with standards, the selection system, two-storied high forest, &c. It may also occur in

young woods, where a slow-growing valuable species is threatened by a faster-growing one. In such a case it may be preferable to prune the latter instead of removing it altogether.

Trees with many side branches, which have been subjected to unfavourable conditions of growth, frequently show signs of failing strength in the upper part of the crown. By removing the lower branches, the vigour in the upper part may be restored. This case applies specially to Oak standards, the boles of which, exposed to light after a prolonged crowded growth, have developed epicormic branches.

## 2. *Dangers connected with Pruning.*

The removal of dry branches or remnants of branches is not, as a rule, conducive to any danger to the life or health of the tree, provided the operation be carried out in a careful way. On the contrary, it often reduces the danger from rot, because it facilitates the process of occlusion, or covering over of the wound by layers of new wood.

Matters are different in the case of green branches. Here the wound caused by the removal of the branch frequently causes rot, because the unprotected open wound offers a fit germinating bed for the spores of fungi; or the wound, on drying, opens out in rents and cracks, into which rain-water may carry the spores; the latter germinate and cause decomposition, which spreads and reduces the value of the stem or may entirely destroy it. Several dangerous parasitic and saprophytic species of fungi thus enter trees.

It is essential, therefore, that the wound should be

closed as quickly as possible and made impermeable to the spores of fungi and to water. This is effected by nature through the process of occlusion, provided the wound does not exceed a certain size. The time required for this operation depends on the size of the wound, the vigour of the tree, the manner in which the wound is made, and above all, on the species.

Pruning green branches is least dangerous and objectionable in the case of Oak and Conifers which are in vigorous health, provided the operation is carefully done and the wound does not exceed 3 inches in diameter. Oak closes the wound rapidly by occlusion, while wounds on Conifers exude turpentine, which protects them to a considerable extent.

As regards other European species the evidence is at present conflicting. Pruning green branches of Poplars, Birch and Willows is undesirable, because their wood is liable to rot quickly. According to Hess some of the important species may be arranged in the following descending series in respect of the activity of occlusion:—*Broad-leaved species*: Oak, Beech, Hornbeam, Lime, Ash, Maple, Birch. *Conifers*: Larch, Silver Fir, Scotch Pine, Spruce.

Under any circumstances the pruning of green branches should not be undertaken without due consideration of the advantages which are likely to be realized and the disadvantages connected with the operation; this is of special importance in all cases where the objects of management centre in the production of large-sized timber, which can only be obtained by permitting the trees to grow and increase for many years after the pruning has been carried out.

### 3. *Execution of Pruning.*

Where the object is to produce valuable timber trees, the branches should, in all cases, be cut off close to the main stem, but without injuring the bark of the latter ; only in this way can quick occlusion of the wound be expected. If the object be merely to relieve young growth of cover overhead, the above rule may be neglected.

The work may be done with the knife, hatchet, billhook, shears, or saw. Cutting instruments produce a smoother surface of the wound, but, unless very carefully handled, injuries to the bark of the main stem are likely to occur. The saw produces a less smooth surface, but if carefully handled it does no injury beyond the actual cut. Heavy branches should first be cut off some distance from the stem, and then, by a second cut, the remaining stump should be removed, to insure the production of an even cut and to avoid tearing the bark of the main stem.

Saws are used, either in connection with a light ladder, or they are placed on poles. In the first case pruning can be carried out to a considerable height. Saws placed on poles are only effective up to a moderate height, 12 to 18 feet.

Of hatchets that constructed by Courval (Fig. 75) is specially recommended. Fig. 76 represents a pushing chisel, with which branches can be removed up to a moderate height. Fig. 77 is a bow-less saw, and Fig. 78 an ordinary hand-saw. Fig. 79 is a saw in the shape of a bayonet fastened on a pole. Fig. 80 represents Ahler's pruning saw, which is also fastened on a pole. The last



Fig. 75.



Fig. 76.



Fig. 77.

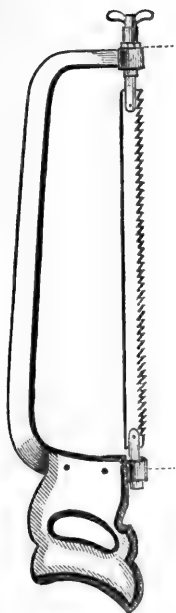

Fig. 78.



Fig. 79.



Fig. 80.

mentioned is specially recommended, where the use of a ladder is not preferred.

Wounds which are so large that they are not likely to be speedily closed by occlusion, must receive a water-proof covering; this is necessary even in pruning large branches of coniferous trees.

The most suitable covering consists of a layer of coal tar, made sufficiently fluid by an addition of oil of turpentine, and laid on with a brush. The artificial covering will only stick on when the sap is down; hence in temperate Europe the best time for pruning is autumn and the first half of winter. Dry branches, and snags may be cut off at any time of the year, provided the living tissue of the tree is not injured during the operation.

According to R. Hartig, pruning green branches while the tree is in sap, causes a somewhat rapid decomposition of the wood near the wound. For this reason, also, pruning in the first half of winter is recommended.

### C. Thinning.

#### 1. *General.*

One of the most important objects in the formation of a wood is to stock the area sufficiently, so that a complete cover overhead may be established as early as possible. This is desirable, not only for the preservation of the soil, but also for a proper development of the trees. In order to ensure quick closing overhead, it is necessary to bring on to the ground a much larger number of plants than can find room on it for any prolonged period. Soon after a complete

leaf-canopy has been established, the trees commence pressing one against the other, there is not enough growing space for all, and then a *struggle for existence* sets in. A portion of the trees outgrow the rest, and they rear their heads up to the full enjoyment of the light. Between and below them are the rest of the trees; some of these still enjoy with their leading shoots light from above, though they are already dominated trees; others have already been left behind to such an extent that they are actually deprived of the direct enjoyment of light, in other words they are suppressed; they live on for a shorter or longer period, according to species and other circumstances, and then die.

Thus there are four classes of trees, namely:—

- (1.) Dominant trees.
- (2.) Dominated trees.
- (3.) Suppressed trees, as yet alive.
- (4.) Dead trees.

This struggle, if not interfered with, continues whilst height-growth lasts, and it generally reduces the growing space of each dominant tree to such an extent that the latter cannot develop in the most advantageous manner; on the contrary, such trees are likely to assume a thin, lanky shape, so that they are frequently unable to stand upright, if deprived of the protection of their immediate neighbours. They are liable to be bent and broken by wind, snow, or rime. To obviate such a state of affairs, the forester interferes in good time by removing a portion of the trees; he *thins* the wood. Thinnings, then, are cuttings, which have for their object to provide for each tree left standing that growing space

which is best suited for its further development according to the objects of management. It is necessary to explain this somewhat in detail.

## 2. *The most suitable Growing Space.*

As the objects of management differ, so must the most suitable growing space. Apart from this, the growing space differs according to the age of the wood; the species; the soil, elevation, and aspect of the locality.

### *a. Objects of Management.*

A tree growing in a free position, in complete enjoyment of vertical and lateral light, will develop a full crown and root-system, and lay on a maximum of volume. This is no doubt a great point, but it is counterbalanced by serious drawbacks:—

In the first place a wood grown in this fashion does by no means always produce the greatest volume per acre, as the total production is represented by the average volume per tree multiplied by the number of trees per acre. Although each tree in a crowded wood has a smaller volume than one grown isolated, yet owing to the greater number of trees per acre, a crowded wood may have, and generally has, a greater total volume per acre than one in which the trees grow isolated. Secondly, isolated trees are liable to suffer in height-growth and in straightness. In the third place, such trees are frequently covered with branches low down, and in consequence they produce less valuable timber. In the case of Conifers the timber is also liable to be of an inferior quality, owing to the greater breadth of the concentric rings. Last, but not least,



open woods cannot preserve the fertility of the locality ; hence they are only admissible on fertile localities, or special measures must be taken to preserve the fertility of the soil.

These considerations govern the most profitable growing space in any particular case. It is conceivable that under certain conditions the correct policy is to remove all dead, suppressed, and dominated trees, and even a portion of the dominant trees, while in others the dominated and even suppressed trees may have to be carefully husbanded, so as to realize the objects of management in the highest possible degree.

*b. Age of Wood.*

As the number of trees per acre decreases gradually from several thousands to a comparatively small number at maturity, it follows that the growing space increases with advancing age, though not evenly. Statistics collected on this point in the Black Forest by Professor Schuberg, gave the following results for mixed forests of Spruce, Silver Fir, Scotch Pine, and Beech :—

Age of wood in years.	Number of trees per acre.	Mean growing space per tree in square feet.	Decrease in the number of trees during twenty years.	Increase of growing space per tree in per cent.
20	3960	11	—	—
40	1013	43	2947	291
60	449	97	564	126
80	346	126	103	30
100	262	166	84	32

These data show that the increased requirement of space between the 20th and 40th year amounts to

291 per cent. of that in the 20th year, that it sinks to 30 per cent. between the 60th and 80th year, and that it is stationary between the 80th and 100th year, after which it gradually becomes very small until it falls to nil. Hence, many trees must be removed during the earlier part of a wood's life, and comparatively few afterwards, always assuming that the area is to remain fully stocked.

*c. Species.*

Light-demanding species require more space than shade bearers. Schuberg's statistics for the Black Forest give the following proportion, for woods ranging from 40 to 80 years of age, placing Scotch Pine equal to 100:—

Scotch Pine . . . . .	100
Spruce . . . . .	87
Beech . . . . .	79
Silver Fir . . . . .	63

Comparing Scotch Pine, Larch, Oak, and Birch with Spruce, Beech, and Silver Fir, the proportion is about 100 to 65.

*d. Soil.*

Until some time past middle-age, the number of trees is larger on poor than on rich soil; afterwards the difference disappears. The reason is, that the struggle for existence commences earlier and is more energetic on good than on poor soil. In this respect considerable differences exist between the various species.

*e. Altitude.*

Under otherwise equal conditions, the number of trees per acre increases with altitude, at any rate up to a certain elevation. The statistics of the Black Forest for

the three regions approximately indicated as below 1200, 1200—2400, and 2400—3600 feet, showed the following proportion in the number of trees:—100, 126, 244. This law could not be established above 3600 feet, because at that height regular woods disappeared. It was further noticed, that the difference is more pronounced in the case of shade-bearing species and during the earlier part of life, than in the case of light-demanding species and later on in life.

*f. Aspect and Slope.*

Aspect in itself causes only slight differences in the growing space. Southern and western aspects, in the case of Beech in the Black Forest, had up to 5 per cent. more trees than northern and eastern aspects. Sloping ground has probably the same number of trees as level ground, other conditions being equal.

*g. Summary.*

It may be said that the average growing space per tree is greater in old woods, in the case of light-demanding species, on good soil, and in low elevation, than under reverse conditions.

In judging of the desirability and the degree of thinning in any particular wood, the forester must take into consideration—

- (1.) The objects of management.
- (2.) The density of the crop.
- (3.) The age of the crop.
- (4.) The species.
- (5.) The character of the locality, its soil, climate, and the special external influences to which it is exposed.

### 3. *The Theory of Thinning.*

Whatever the objects of management may be, the theory of thinning may be summarised in the answers to the following three questions:—

- (1.) At what age of a wood should thinnings commence?
- (2.) To what trees should they extend—in other words, how heavy should the cuttings be?
- (3.) After what intervals should they be repeated?

Definite answers to these questions can only be given on the basis of accurate comparative statistics. The collection of such data is now in active progress in Europe, but some time must necessarily elapse before final conclusions can be drawn from them; in the meantime, only the results of general observations are available for guidance.

It has been explained above that during the struggle for existence, four different classes of trees are produced, namely, dominant, dominated, suppressed, and dead trees; and the question arises in how far each of these should be interfered with at each thinning. It is obvious that the dead trees must be removed at every thinning, as they cannot influence the other three classes; while their presence in the wood is a constant source of danger from insects and fungi, and in some cases from fire. Except in some special cases, the suppressed trees also should be removed, but the extent of interference with the dominated and dominant trees depends, apart from species, chiefly on the character of the locality and the objects of management. On fertile soils an interruption of the cover overhead is of comparatively small importance, but on inferior and even middling soils this

should be avoided. In such cases the dominated trees, or at any rate a portion of them, must be retained whenever the dominant trees alone are not sufficiently numerous to provide a complete leaf-canopy. If, on the other hand, the number of dominant trees is so large that they interfere with each other's proper development, not only the dominated but also a portion of the dominant trees may be removed.

As regards the objects of management, it suffices in practical Sylviculture to distinguish between the following two cases:—

- (a.) Production of the greatest quantity of material.
- (b.) „ „ highest quality „

In some cases the two objects may be realized by an identical treatment, in others the one demands a method of thinning different from that which is desirable in the other.

*a. Production of the greatest Quantity of Material.*

Experience has shown that the greatest quantity is produced in the shortest possible time by a vigorous development of the dominant trees; so that the dominated trees are only retained so long as they are required for the protection of the soil.

i. COMMENCEMENT OF THINNINGS.

The first thinning should be made as soon as the struggle for existence has commenced, that is to say, when there is no longer sufficient space for the proper development of all trees. Such early thinnings are to the interest of the dominant trees, which are thus enabled to lay on an extra quantity of wood, and they

acquire a greater power of resistance against snow, rime, and wind. In practice they are sometimes delayed, because their execution involves expenditure which may not be covered by the receipts from the sale of the thinned-out material. The financial loss thus incurred may, however, be more apparent than real, as it is generally more than covered by the favourable development of the remaining trees.

#### ii. DEGREE OF THINNING.

A thinning is called :—

“Light,” when only dry and suppressed trees are removed ;

“Moderate,” when, in addition, the whole or part of the dominated trees is removed ;

“Heavy,” when also a part of the dominant trees is cut.

In the present case, where quantity is the object, the thinnings should on the whole be heavy, subject to the special requirements of the species and the preservation of a sufficient leaf-canopy. As the demands on the growing space are very great during the first half of life, thinnings must then be comparatively heavier than later on ; heavier in the case of light-demanding and quick-growing than in that of shade-bearing and slow-growing species ; heavier on good soil than on poor.

Much depends on the original density of the wood ; hence, direct sowings, and woods resulting from natural regeneration generally require heavier thinning than plantings.

#### iii. REPETITION OF THINNINGS.

Thinnings should be repeated whenever they become necessary. The more energetic the growth, the quicker

should the thinnings follow each other; hence the intervals will be comparatively short during the first half of life, and they become longer with advancing age. For the rest, the length of the intervals depends on the species and the soil.

A frequent repetition of the thinning should not be obviated by thinning too heavily at any particular time; such a measure would not secure the most favourable development of the dominant trees.

In summing up it may be said that, where the object is to produce quantity, the thinnings should commence early, be heavy, and frequently repeated during the first half of the life of a wood, and be more moderate and repeated at longer intervals during the second half.

*b. Production of High-class Timber.*

Where the production of high-class timber is aimed at, quantity must to some extent be sacrificed. Trees fit to yield such timber must answer the following description:—

- (1.) The boles must be tall, straight, free of branches, and as little tapering as possible.
- (2.) Differences in the breadth of the concentric rings must be slight.
- (3.) The timber must have a high degree of density.

Boles free from branches and non-tapering are not produced, if heavy thinnings are made at an early age of the wood; at any rate not in the same degree as if the wood were kept dense, when the lower branches are more rapidly killed for want of light. Pruning cannot make up for this, though it can do something.

There is naturally a tendency to produce broader rings during youth than later on; heavy thinning at an early age increases the difference, leading to the formation of trunks which consist of a number of broad rings in the inner part, surrounded by a series of narrow ones. Such timber is for many purposes of smaller value than if the rings are of uniform breadth throughout.

As regards the density of the timber, a distinction must be made between the various species. In the case of those broad-leaved species which have the pores in the spring-portion of the wood, broad rings indicate high quality, and narrow rings comparatively low quality; here then, heavy thinnings are indicated. The same probably holds good for species which have the pores uniformly distributed over the ring. In conifers, however, the matter is exactly the reverse. There, broad rings represent inferior quality and narrow rings the reverse; consequently heavy thinnings must be avoided, at any rate up to a certain age.

On the whole it may be said that, in the production of high-class timber, heavy thinnings at an early age should be avoided. The rule here, according to which the thinnings are to be made, must run as follows:—

The wood should be thinned lightly until towards the end of the principal height-growth; then the thinnings should gradually become heavier, so as to assist a selected number of trees by the gradual removal of all those which are inferior and diseased. In other words, the thinning is done more in the dominant and dominated trees than in those which have been left behind in the struggle for existence and no longer com-



pete; the latter may even be left to assist in the protection of the soil. Deviations from this rule are to some extent admissible in the case of species having their pores in rings, when heavier thinnings may commence at a somewhat earlier age, in so far as they do not prevent the clearing of the boles.

#### 4. *Thinning of Mixed Woods.*

In the foregoing pages the theory of thinning as applicable to pure woods has been given. Generally, the points aimed at are to stimulate production and to develop the most suitable individuals for the final crop. In mixed woods a third consideration presents itself, in the preservation of a suitable mixture without interfering with the maintenance of a sufficient leaf-canopy; this often leads to deviations from the theory as indicated above.

In the case of mixed woods it may often be necessary to remove a dominant tree of one species because it threatens to suppress a tree of another species, which must be preserved for the sake of the mixture. To guard against an interruption of the cover in such cases, the dominated and even suppressed trees must be more carefully husbanded than in pure woods, until, with the advancing age of the wood, the mixture has been secured. Frequent and light thinnings are in such cases indicated. Their actual degree depends much on the light requirements of the valuable species in mixture. The operation is much facilitated if the several species are mixed in groups instead of by alternating single trees.

Where a valuable timber species is mixed with a less

valuable one, the former must be favoured from an early age, so as to bring it to the highest possible development, if necessary at the expense of the less valuable species. As long as the valuable species is of quicker growth than the other, the operation is comparatively simple; but if it is of slower growth, all individuals of the secondary species which threaten to overtop it must be cut away, until the principal species is secure.

### 5. *Thinning of Coppice Woods.*

These thinnings are conducted according to the same principles as in high forest, whenever the number of shoots is so great that there is not enough growing space for all. More especially in Oak coppice the quality and quantity of bark may be considerably influenced by leaving on each stool only the two or three best shoots and removing the others. Such thinnings are generally made in the second half of the rotation.

### 6. *Principal Advantages of Thinning.*

The principal advantages of thinning are as follows:—

- (a.) They afford the means of guiding the development of a wood in accordance with the objects of management, either by producing the greatest possible quantity, or the best possible quality of produce; in many cases both these objects may be combined.
- (b.) They afford the means of preserving a suitable mixture in the case of mixed woods.
- (c.) Danger from insects, fungi, and fire is greatly

reduced by the prompt removal of dead and sick trees.

(d.) They afford the means of strengthening the trees destined for the final crop against damage by snow, rime, and wind.

(e.) They yield substantial early returns.

The returns from thinnings should by no means be under-estimated, especially where the object of management centres in the production of quantity. According to the yield-tables of Weise, Scotch Pine may be expected to yield the following returns under a rotation of 90 years:—

Quality Class of Locality.	Returns in solid cubic feet.			Proportion of intermediate to final returns, in per cent.
	Intermediate returns, or Thinnings.	Final returns.	Total.	
<i>A.—Timber and Fagots.</i>				
I., or best .	5,340	8,670	14,010	62
II. . .	4,040	6,780	10,820	60
III. . .	3,210	5,300	8,510	61
IV. . .	2,230	4,170	6,400	53
V., or worst	1,130	3,300	4,430	34
<i>B.—Timber of 3 inches diameter and upwards only.</i>				
I. . . .	3,950	7,950	11,900	50
II. . . .	2,970	6,100	9,070	49
III. . . .	2,120	4,620	6,740	46
IV. . . .	1,320	3,530	4,850	37
V. . . .	600	2,690	3,290	22

### 7. *Execution of Thinnings.*

The advantages of thinnings can only be fully realized if the operation be conducted in a careful and judicious manner; in other words, it must be attended to by a competent forester and not left to the wood-cutters.

In young woods, which have as yet a large number of trees per acre, thinnings should generally be carried out in the presence of a competent forester; only where the wood is absolutely uniform throughout, a sample may be prepared as a guidance for the workmen, and this only if the latter are thoroughly reliable and competent. In the more advanced stages of life, each tree to be removed should be marked separately and in the forester's presence, and this must be done while the trees are in leaf, so that the effect of the removal may be properly judged. Special care is necessary where valuable timber trees are to be produced, where dominant trees are to be removed, and where a proper mixture of species is to be preserved.

The exposed edges of a wood should be thinned where the trees must be trained to withstand strong winds. If the wood be subject to the effects of raw cold, or dry hot winds, the exposed edge should be kept as dense as possible, and an additional strip some distance from it may be kept in a similar condition.

The best time for the execution of thinnings is winter, but local circumstances demand deviations from this rule. In high mountains they must be done in summer, as the localities are generally inaccessible during winter.

### SECTION III.—TENDING OF OPEN WOODS FOR THE PRODUCTION OF LARGE TIMBER.

#### 1. *The Theory.*

In the foregoing section it has been shown how thinnings should be conducted, if the principal part of a wood—the dominant trees—are to be given increased space and enjoyment of light, followed by increased increment, without, however, interrupting the leaf-canopy to such an extent as to affect injuriously the continued activity of the soil. Under this method of treatment, the one aim acts antagonistically to the other, and it is by no means easy to conciliate the two interests. Hence the problem presents itself, whether the better portion of the dominant trees cannot be more completely isolated, while the soil is protected by other means. There are other considerations which press the subject upon the attention of the forester. Under the ordinary system, as described above, the production of large-sized timber demands a high rotation, and any measures which tend to reduce the latter must be welcome. Experience has shown that by isolating the trees, timber of a certain size can be produced in little more than half the time required under the method of continuously crowded woods.

Another point is, that many, and more especially the light-demanding species, have a natural tendency to open out, or to form large crowns.

It is of additional importance that under a system of heavy thinnings, considerably larger intermediate yields are obtained early in the rotation. This, in conjunction

with the more rapid development of the trees constituting the final crop, leads to more favourable financial results.

On the other hand, the early isolation of a portion of the trees has weighty drawbacks. In the case of many species it affects injuriously the height-growth of the trees. Then, isolated trees maintain their side branches low down, and even develop fresh ones, which seriously reduce the value of the stems for many purposes. In the case of conifers the quality of timber will also be lower, owing to the formation of exceptionally broad concentric rings. Isolated trees are further liable to form more tapering boles than those grown in crowded woods. Above all, in the majority of cases a sufficient layer of humus and a suitable degree of moisture cannot be preserved. It follows that, except on really fertile soils, other means must be devised to preserve the continued activity of the soil. This is done by the introduction of an underwood, or soil-protection wood. But even then it is found that the extra increment, laid on after isolating the trees, will only hold out on soils of some quality, while on indifferent soils it will after some years sink back to its previous amount.

The general theory of the method of treatment in the case under consideration may be shortly described as follows:—

Commencing with the first thinnings, the most promising trees are singled out, and these are isolated sufficiently by increasingly heavy thinnings, so as to permit the introduction of an underwood. As soon as the latter has established itself, and is capable of protecting the soil, a further heavy thinning is made, by which the remaining trees are completely isolated. Subsequently

more thinnings follow, as required by the extension of the crowns of the trees.

The underwood can be established in a variety of ways, such as by sowing or planting, by natural seeding, or by coppicing a portion of the overwood. In some cases the underwood itself is allowed to grow into timber-trees (two-storied high forest); in others it remains a soil-protection wood.)

The procedure differs considerably according to species and the objects of management. To meet the special requirements of each case, a considerable number of modifications have been elaborated. Some of these commence with the isolation in early growth, while others during the greater part of the rotation follow the system described in the last section, and reserve to its latter part the isolation of the more valuable trees.

Although the treatment has been recommended for almost all species, it is easy to perceive that thinly-crowned species, which are generally light-demanding, are better adapted for the method than those with a dense crown, as the underwood has a better chance of thriving under the former, and doing justice to the task which it is called upon to perform. In Britain the Oak, Larch, and Scotch Pine have, in a rough way, been treated according to this method for a long time past. On the Continent, the treatment has been elaborated in comparatively recent times.

## 2. *Principal Forms of Treatment.*

These may be enumerated as follows :—

*a. Isolation of a few Selected Trees, without Underwood.*

A limited number of selected trees are placed in a free position, by removing all surrounding trees which threaten to interfere with them. The system should only be applied in case the main part of the wood consists of a species with full crowns, and where the selected trees are of quicker height-growth than the rest.

To avoid loss of height-growth and the retention of low side branches, the operation should not be commenced until towards the end of the period of principal height-growth.

The treatment is specially adapted to mixed woods of Beech, and light-demanding broad-leaved species, such as Oak, Ash, and Elm.

*b. Prolongation of the Regeneration Period under the Shelter-wood Systems.*

Woods treated under artificial or natural regeneration under a shelter-wood offer excellent opportunities for the realization of the extra increment due to an isolated position of a limited number of trees. In the same degree as the shelter-wood is thinned out by successive cuttings, the remaining trees profit by accelerated increment; the process can be further extended by retaining a limited number of trees for an extra term of years, or by prolonging the regeneration period.

The method is specially adapted to thin-crowned, wind-firm trees. Shallow-rooted trees are likely to be thrown by wind, while the injurious effect of close-



crowned trees upon the young growth must be mitigated by pruning away the lower branches of the shelter trees.

*c. Retention of Standards in High Forest.*

A limited number of the most suitable trees are, after the wood has been regenerated, retained as standards for part or the whole of the second rotation, and in some cases even for a third rotation. Only wind-firm species are thoroughly suited for such treatment, and they should, moreover, be thin-crowned. The number of standards depends on the density of their crown and the quality of the soil; only perfectly healthy, well-formed trees should be chosen, especially those which have cleared themselves of branches to some height, to obviate the necessity of pruning. The tending of the proposed standards may usefully be commenced some time before the end of the first rotation, as indicated under *a*.

*d. Isolation of Trees in conjunction with an Underwood.*

A wood is uniformly thinned, and an underwood is formed by sowing, planting, natural seeding, or by coppicing a portion of the overwood. Thoroughly satisfactory results are only obtained if the overwood consists of thin-crowned, and the underwood of shade-bearing species. In temperate Europe, Oak, Ash, Elm, Larch, and Scotch Pine are the species specially suited for the overwood, and Beech, Hornbeam, Silver Fir, Spruce, and in some cases Sweet Chestnut and Hazel for the underwood. Sometimes the underwood is itself

allowed to grow up into trees ; in other cases it is only treated as a soil-protection wood, and is periodically coppiced. Beech makes the best underwood, as it bears much shade and improves the soil more than any other species. Silver Fir comes near it. Hornbeam is best in frost localities. Spruce should only be used in fresh localities, as on dry soil it may cause the overwood to fall off in growth.

Where the underwood is permitted to attain the size of timber-trees, it is either cut with the overwood, or the latter may be retained for two rotations of the underwood, thus producing specially large timber.

A few remarks on the tending of the more important species will further illustrate the method.

#### i. OAK AS OVERWOOD.

A fully stocked Oak wood is, when the time for thinning has arrived, thinned rather heavily at frequent intervals, say every 5 to 10 years according to the locality ; during these operations all trees with a tendency to lag behind are removed, as well as ill-shapen and diseased trees. At the age of 40 to 60 years, according to circumstances, a specially heavy thinning is made and the underwood started, Beech being best for the purpose. When the underwood has established itself, say 10 to 15 years afterwards, another heavy thinning is made, by which the remaining trees are isolated. Subsequently more thinnings follow, at moderate intervals, in the same degree, as the Oaks develop and threaten to close up again.

It is estimated that in this way about 50 Oak trees

per acre can be made to reach a size in 120 years which in a fully stocked wood they would only reach in about 200 years.

#### ii. LARCH AS OVERWOOD.

This being a quicker growing and shorter lived tree than Oak, the first specially heavy thinning and underplanting may be done between the 20th and 30th year. The underwood should consist of Beech. Silver Fir is also recommended, but it grows slowly during the early part of its life. Another excellent species for underplanting may be found in the Douglas Spruce. Possibly, Weymouth Pine may answer. The two last-mentioned species are of quick growth.

In this manner about 75 Larch trees per acre may be brought to large timber size in 70 to 80 years.

#### iii. SCOTCH PINE AS OVERWOOD.

The heavy thinning and underplanting may take place between the 30th and 50th year. Beech is an excellent underwood, but Spruce is also admissible in this case. Possibly the Douglas Fir may do, where the locality is suitable. The last-mentioned species grows so rapidly, that it will reach timber size at the same time as the Scotch Pine.

#### iv. OTHER SPECIES AS OVERWOOD.

Ash, Elm, and Sweet Chestnut may be treated in a manner similar to that indicated for Oak. Various other species, such as Spruce, Silver Fir, Beech, either pure or mixed, have been tried and recommended for treat-

ment under this method, but it would be beyond the scope of this manual to enter into a discussion of the question, under what conditions and in how far they are suited for the purpose.

### 3. *Execution of the Work.*

The selection of the trees for removal must be most carefully considered, as mistakes made in this respect are difficult to rectify. The main point is, that almost from the first thinning the trees likely to form the final crop are favoured and trained for their ultimate purpose. They should consist of the best trees which are likely to develop into fine, valuable timber-trees of large size; to enable this favoured portion of the wood to reach such proportions in the shortest possible time, much of the rest of the wood must be sacrificed. This must not be done unless the sacrifice is more than covered by the special excellence of the final crop, a case which can only be expected to occur on fairly favourable localities, which insure a special increment of the isolated trees during a considerable period of time.

## CHAPTER IV.

## SYLVICULTURAL NOTES ON BRITISH FOREST TREES.

THE theory and practice of Sylviculture, as described in this work, have been illustrated by instances taken from the more important forest trees grown in temperate Europe. For the sake of reference, it will be found useful to bring these scattered remarks, and other information, together in a set of notes on each of the trees which are of real sylvicultural importance in Great Britain and Ireland. For the present the number of species referred to has been limited to twenty; on a future occasion it may be possible to add other less important forest trees.

The trees naturally arrange themselves into two groups, the broad-leaved and coniferous species. Of each group the important shade-bearers have been placed first, as the notes on the light-demanders depended on those for the former.

Generally, the notes have been made as short as possible; if a full account of each tree had been given, this chapter would have attained the size of a book. Apart from the author's own experience, they have been derived from the best authorities. The following explanations will be useful:—

(1.) The average specific gravity of air-dried wood has been taken from Hess' "Die Eigenschaften und das

forstliche Verhalten der wichtigeren in Deutschland vorkommenden Holzarten."

(2.) Under volume-increment is here understood the mean annual production per acre in crowded woods calculated from the increment of the most favourable rotation.

(3.) The information about insects refers principally to Britain.

### 1. BEECH—*Fagus sylvatica* (L.).

#### *a. Utility.*

Beech yields excellent fire-wood, and very good charcoal. The timber is not of much value where strength and durability is wanted; it is brittle and short grained. Specific gravity, air-dried, on an average = .74. Under water it lasts well. Formerly the timber was much used in machinery, especially by millwrights; now-a-days iron has replaced it for many purposes. Beech wood is still used for furniture, in carpentry, turnery, &c., more especially for the manufacture of chairs in Buckinghamshire and adjoining counties. On the continent it is much used for packing-cases and barrels. The leaves are used for litter, the nuts as fodder for pigs and deer; the seeds yield a superior oil. The wood is rich in potash.

#### *b. Distribution.*

It is found in temperate Europe from Norway to the Mediterranean, or between the 40th and 60th degree of

latitude, also in western Asia ; it is apparently indigenous in England, and found planted in Scotland and Ireland. It is a tree of the lower mountains and plains ; going up to about 700 feet in Norway, 1200 feet in Derbyshire, 4500 feet in the Alps, and over 6000 feet on Mount Etna.

*c. Locality.*

*Climate.*—Beech is fairly hardy as regards winter frost, but very sensitive to late spring frosts, which, during early youth, frequently injure or even kill it. It stands more shade than any other indigenous broad-leaved species, but somewhat less than Silver Fir. It requires a fair amount of moisture in the air, hence it grows well in the vicinity of the sea and on northern and eastern slopes, while it disappears in the eastern part of Europe owing to the drier continental climate. It is liable to be thrown by strong winds, but not to any excessive extent.

*Soil.*—Beech requires a soil which is at least of middling depth, of a moderate degree of porosity, fresh and fertile ; it thrives best on loamy soils, and especially on marls, and on calcareous soils generally ; also on sandy soils, provided they are thoroughly fresh, and contain water at a moderate depth in the subsoil. Wet soils are unsuited, and inundations fatal, to Beech.

*d. Shape and Development.*

The stem of the Beech divides, as a rule, only in the upper part ; the crown remains oval until towards the end of the principal height-growth, when it becomes

flat or rounded off at the top. Owing to its shade-bearing power, the crown extends far down the stem, unless the tree is grown in crowded woods, when it occupies about the upper-third of the height of the tree.

The root-system extends to a moderate depth, the tap-root being of no importance after the first 5 or 6 years. It is of slow height-growth during the first years of life, compared with other broad-leaved species; when from 20 to 30 years old, the rate of height-growth increases, so that it outgrows the other broad-leaved indigenous species, frequently even the Oak, reaching an ultimate height of about 110 feet under favourable conditions.

Spruce, Silver Fir, Larch, Weymouth and Scotch Pines attain a greater height than Beech, though the two first species grow slower during early youth.

The volume-increment of Beech is greater than that of the other indigenous broad-leaved species, but smaller than that of the principal conifers.

If grown in crowded woods, Beech rarely reaches an age of more than 200 years; in the open, it attains a much higher age.

#### *e. Reproductive Power.*

Beech commences producing full crops of good seed at the age of about 60 years; it yields heavy crops, but full masts cannot be counted on at shorter intervals than 5 years, and often 10 to 15 years, according to local circumstances; partial masts occur during the intervals. Taking both factors together, the reproduc-



tion of Beech by seed is less favourable than that of most other indigenous species.

Reproduction from the stool is feeble, as compared with other broad-leaved species ; it ceases after the age of 40 years, and the stools rarely last for more than three or four rotations ; it is best on marls.

*f. Character and Composition of Woods.*

Beech is eminently adapted for growing in pure woods, since it shades the soil thoroughly up to an advanced age, maintains and even improves its fertility, and bears much shade. For the same reasons it is equally well adapted to form the principal constituent of mixed woods. Probably no other species equals it in this respect. Trees like Oak, Ash, Maple, Elm, Silver Fir, Scotch Pine, Larch, and also Spruce thrive best when mixed with Beech ; in fact this is the case with almost any species which thrive on localities suitable for Beech.

*g. Sylvicultural Systems.*

Beech is specially adapted for high forest. It is less well suited for coppice woods, owing to its feeble reproductive power from the stool. It appears as underwood in coppice with standards. In high forest the rotation should range between 80 and 120 years, in coppice between 20 and 35 years.

In high forest it is grown in even-aged and uneven-aged woods ; large areas are treated as selection woods (Buckinghamshire). It is the best species for under-planting open woods of valuable timber trees.

*h. Formation of Woods.*

Beech is specially adapted for natural regeneration by seed under shelter-woods, if the cuttings are arranged in a suitable manner. Direct sowing and planting can also be done, but the young crop must be sheltered whenever late frosts and drought are apprehended.

The seed ripens in October, and falls shortly afterwards, retaining its germinating power for about six months. Up to 80 or 90 per cent. have been found to germinate, but it is considered good seed if at least 50 per cent. germinate. One pound of seed contains, on an average, about 2000 nuts.

Direct sowings may be made in autumn or spring; in the former case the seeds are liable to attacks by animals, and the seedlings, owing to their early sprouting, to damage by spring frosts; in the latter case the nuts must be kept in an airy place or shed, and turned over periodically (during dry weather towards spring it may be slightly sprinkled with water to prevent drying up). If sown in spring, the nuts sprout after four to six weeks. About 150 pounds of seed per acre are required for broadcast sowings, and proportionally less for partial sowings. The nuts receive a covering of three-quarters of an inch on soil of middling density, somewhat more on loose and a little less on heavy soil.

In nurseries, the seed is generally sown in drills. The seedlings may be left in the seed bed for two years, when they are pricked out in lines, the latter being from 12 to 24 inches apart, and the plants in the lines from 4 to 8 inches. When the plants have stood two years in the lines, being then altogether four years old, they are

ready for putting out into the forest. They are usually planted in pits. As a general rule, the seedlings and young plants require protection in the nursery against frost as well as against hot sun.

It is not desirable to prune Beech plants.

The process of natural regeneration under a shelter-wood is, on the whole, slow; one or more preparatory cuttings are required, and if the soil be not sufficiently prepared at the advent of a seed year, it must be worked (wounded); the seeding cutting is comparatively light, and the cuttings in the final stage are regulated by the character of the locality and the requirements of the young crop. Under favourable circumstances the whole regeneration period may be completed in 10 years, but frequently extends to 20 years and even more.

#### *i. Tending.*

*Fertility of the Soil.*—Fully-stocked Beech woods preserve and even improve the fertility of the soil to a greater extent than any other species, owing to their dense foliage up to an advanced age, and the heavy fall of leaves.

*External Dangers.*—Late frosts are the greatest enemy of Beech; during early youth they kill or seriously damage the plants, and even later on the tender parts of the tree are liable to suffer; hence it must be raised under shelter, which is provided either by the old crop, or by a special shelter-wood of hardy species, such as Scotch Pine, Birch, and Larch; Austrian Pine will also do. In natural regenerations, the edges of the shelter-wood must be kept as dense as possible to afford protection

against cold winds. In the cultivation of blanks, artificial shelter belts must be grown some years beforehand, on the side whence the cold winds blow.

Beech suffers also from drought while young. Later on it is more than any other species exposed to blistering of the bark by the sun; hence it is not well suited for standards, apart from the heavy cover which the tree gives.

Storms, snow, and rime are only to a limited extent hurtful in Beech woods.

Cattle and game like to browse Beech; red deer, hares, rabbits and mice peel off the bark. Insects rarely do much damage. The leaves are devoured by lepidopterous larvæ, especially those of *Dasychira pudibunda*, and *Halias prasinana*, and sometimes the polyphagous *Liparis monacha*, as well as by the weevil *Orchestes fagi*. An aphid, *Chermes fagi*, sometimes kills old trees. The freshly-cut timber is liable to the attacks of *Tomicidae*, and other boring beetles.

Of fungi, *Phytophthora omnivora* destroys young seedlings; where it appears in large quantities, seedlings cannot be raised for 5 to 8 years, hence nurseries must be changed, or used for other species. *Nectria ditissima* causes cancer on the stem, which may, however, also be the consequence of frost. The so-called green-rot is due to *Peziza æruginosa*.

*Pruning.*—Beech stands pruning better than most other species, but it is rarely, if ever, done unless the shade injures other more valuable timber trees.

*Thinnings* are commenced at the age of 25 to 40 years according to locality; they should be at first moderate, afterwards heavy.

2. HORNBEAM—*Carpinus Betulus* (L.).a. *Utility.*

The hard and heavy wood is an excellent fuel, and it yields good charcoal. The timber is very tough, and is used in machinery by the millwright, for wheels, and a variety of other purposes. Specific gravity of air-dried wood = .72. The ashes are rich in potash. The leaves yield good fodder.

b. *Distribution.*

It is found in temperate Europe up to the 60th degree of latitude. Indigenous in England; planted in Scotland and Ireland. Goes up to 1,200 feet in the Harz mountains, and to about 3,000 feet in the Alps; generally a tree of the low lands and low hills.

c. *Locality.*

*Climate.*—The Hornbeam requires only a moderate temperature, and thrives even in cold moist localities unsuited for Beech. It is one of the most frost-hardy species, but rather tender as regards summer heat. It stands a considerable amount of shade, but not so much as Beech.

It seems to require a moderately moist atmosphere, and prefers north and east aspects. It is to some extent liable to be thrown by wind, but resists snow and rime fairly well.

*Soil.*—Hornbeam likes a soil which is fairly loose, of at least middling depth, thoroughly fresh if not moist, and minerally rich. As regards moisture, it

stands between Beech and Ash, and in respect of mineral matter in the soil, it is not quite so exacting as Beech. Loams, sandy soils rich in humus, and marls suit it best; here it attains its full development. At the same time it is found on dry soils, though of inferior development, and on heavy clay soils; it frequently replaces Beech in heavy soils and in frost localities.

*d. Shape and Development.*

The stem of the Hornbeam is generally divided into branches comparatively low down. The general shape of the tree, if grown in a favourable locality, approaches that of the Beech; on inferior soils it sinks down to an insignificant tree, with a short bole and large crown. The root-system on the whole is not deep-going; there are strong side roots which reach a moderate depth.

It grows somewhat quicker than Beech during the first years of life, but it rarely reaches a total height of more than 75 feet.

Its volume increment is considerably smaller than that of Beech; nor is Hornbeam so long lived as the latter.

*e. Reproductive Power.*

Hornbeam commences bearing full crops of seed when about 40 years old, and it seeds plentifully almost every year; at any rate every other year, so that its power of reproduction by seed is on the whole great.

The reproduction from the stool is excellent; the shoots appear at any part which has been coppiced. The stools last for hundreds of years.

*f. Character and Composition of Woods.*

Hornbeam appears in pure woods in eastern Europe, and also in England (Epping Forest). It is not equal to Beech in its capacity for improving the fertility of the soil, since it has a lighter foliage, does not maintain a cover overhead so long, and does not bear so much shade; the leaves also decompose more rapidly than those of Beech. At the same time, it stands next to Beech in this respect amongst broad-leaved species, and may replace it in localities unsuited for Beech.

Hornbeam appears chiefly in mixture with Beech and Oak, but also, like the Beech, with other species, but not to the same extent.

*g. Sylvicultural Systems.*

Hornbeam can be grown as high forest, coppice, or pollards. It appears as underwood in coppice with standards, and makes an excellent soil-protection wood in open woods of valuable timber trees. It also makes excellent hedges.

As high forest, it would generally be treated under a rotation not exceeding 100 years, as coppice from 15 to 35 years, and as pollards from 5 to 10 years.

*h. Formation of Woods.*

Hornbeam can be sown, planted, or naturally regenerated; the latter is a suitable method. Sowings and plantings do not require shelter.

The seed ripens in October, and falls from that time until towards spring; it keeps its germinating power for two or three years; up to 80 per cent. are capable of

germinating; it is good seed if 70 per cent. germinate. One pound contains on an average about 14000 clean seeds without wings.

The seed germinates only in the second spring, that is to say about eighteen months after ripening. The best treatment consists in bedding it mixed with sand in a ditch, stirring it from time to time, and sowing it in the spring of the second year. About 35 pounds of seed per acre are required for broadcast sowings; it requires a covering of about  $\frac{1}{2}$  to  $\frac{3}{4}$  of an inch.

In nurseries, the seed should be sown in drills; the seedlings may be pricked out when one year old. Plantings are done with plants three years old and upwards. They stand pruning well. The tree can also be propagated by cuttings, which may be several feet long; the latter method may be employed for hedges. In regenerating Hornbeam naturally by seed, the seeding cutting is much heavier than for Beech, while the remaining shelter-wood may be removed much more rapidly, owing to the hardy nature of the tree.

#### *i. Tending.*

Hornbeam is well adapted to maintain the fertility of the soil, but not to the same extent as Beech. It is little threatened by external dangers; the tree is frost-hardy, but during youth liable to suffer from continued drought. Inundations affect it little. Game and cattle browse the leaves, and mice peel the bark, which is also sometimes done by red deer. The damage heals, however, quickly.

The Hornbeam rarely suffers from insect-attacks. The species infesting it are much the same as those of the



Beech. In addition, the larvæ of the Winter moth, *Cheimatobia brumata*, strip the Hornbeam of its young leaves.

*Fungi*:—*Exoascus Carpini* produces witch's broom; cancer on stems and branches is produced either by *Nectria ditissima* or by frost.

On the whole, Hornbeam woods require little tending. The tree stands any amount of pruning. The thinnings are done on similar lines to those referring to Beech, during the first half of life; afterwards Hornbeam thins out naturally more rapidly than Beech.

### 3. OAK = *Quercus* (Tournef.).

The two species of Oak which will be dealt with are the English or pedunculate Oak = *Quercus pedunculata*, Ehrb., and the Sessile-flowered Oak = *Quercus sessiliflora*, Salisb. From a silvicultural point of view they are so much alike that they may be taken together, any differences being specially noted.

#### a. Utility.

Oak timber is the most valuable of the indigenous species; it is heavy, hard, very durable, and splits well; it makes a good fuel. It is used for many purposes, in shipbuilding, housebuilding, implements, machinery, manufacture of casks (as split wood)—in fact for any purpose where a strong durable timber is required. The bark yields an excellent tanning material. The acorns are good fodder for pigs and deer, and are also used for tanning and dyeing. Specific gravity of air-dried wood: Pedunculate Oak = .86, Sessile-flowered Oak = .74.

*b. Distribution.*

*Pedunculate Oak*.—All over Europe up to 60th degree of latitude, in North Africa, and eastwards to Syria. It is a tree of the low lands, but goes up to 1500 feet elevation in England, to 3000 feet in the Alps, and to 4500 feet in Greece. It is indigenous in England, Ireland, and in Scotland up to Sutherland; it ascends to 1350 feet in the Highlands.

*Sessile Oak*.—Does not go beyond the 54th degree of latitude, but rises higher in the hills, up to 4000 feet in the Alps, and to more than 6000 feet on Mount Etna. Somewhat more a tree of the low hills than the pedunculate Oak, but becomes a tree of the low lands in the northern part of Europe.

The pedunculate Oak is much more frequent in Britain than the sessile Oak, but the latter is said to be commoner in Wales.

*c. Locality.*

*Climate*.—Oak requires warm air; it suffers from late frosts, but not so much as Beech, as it sprouts later in spring; it also suffers from severe winter frosts. It is a light-demanding species, which should have its head free to the full enjoyment of light. It does not require much moisture in the air. It is more storm-firm than any other indigenous species.

The sessile Oak requires somewhat less warmth in the air than the pedunculate species; hence it goes higher in mountains.

*Soil*.—Oak requires a soil which is deep, at least fresh, warm, and fertile; it accommodates itself to moist

soil, and is not very sensitive as regards inundations. Fertile loam soils cause its highest development, but it is also found on clay, and on sandy soil if it is sufficiently moist. On the whole it is the most exacting indigenous species. It thrives better on southern than on northern aspects.

The sessile Oak is somewhat less exacting as regards fertility, and requires a little less moisture in the soil; hence it is found in poorer and drier soils than the pedunculate Oak. If grown as coppice, the Oak is less exacting than if grown as a timber tree.

#### *d. Shape and Development.*

The stem of the Oak has a decided tendency to divide into strong branches comparatively low down, forming a large spreading crown, which becomes flat or rounded off with advancing age. The branches are gnarled and knee-bent. The root-system is deep-going, with a strong tap-root. Its height-growth during youth is moderately fast, somewhat faster than that of Beech, which at middle age catches it up. Whether Beech or Oak may ultimately reach the greatest height depends on the locality. Generally Oak does not reach a total height of more than 110 feet. It attains a great age, even up to 1000 years. Oak reaches a large diameter. In volume-increment it stands immediately below Beech.

The shape of the sessile Oak differs somewhat from that of the pedunculate species; its branches tend more upwards, and are less gnarled and knee-bent. Its height-growth is slightly slower.

*e. Reproductive Power.*

Oak commences producing full masts at an age of about 70 years; they occur every three to six years, and are heavy. On the whole, the power of reproduction by seed is fairly good.

The reproduction by shoots is excellent; the shoots spring not only from the stool, but also from the trunk. Stools retain the power of reproduction for a very long time.

*f. Character and Composition of Woods.*

Oak is grown in pure woods, and in mixture with other species. Owing to the decided light-requirement of the Oak and its tendency to form a spreading crown it opens out at a comparatively early age, generally between the 40th and 60th years, when raised in crowded woods; from that time onwards it cannot afford sufficient shelter to the soil, which is liable to deteriorate during the long period required to produce large-sized timber trees. Hence Oak woods should be underplanted when the process of opening out has set in, or the tree must be mixed with species capable of preserving the fertility of the soil. Amongst these, Beech is best, then come Hornbeam and Silver Fir; Spruce is less suitable.

Oak does splendidly in mixture with Beech, attaining a great height and a clear bole of considerable length. In some cases the Oak holds its own against the Beech, in others it is liable to be outgrown; in the latter case the Oak must be placed in small groups, or given a start of the Beech, by planting it pure and bringing in the Beech when the Oak begins to thin out.

Where the locality does not suit the Beech, the Hornbeam frequently takes its place; instances are frost localities and sandy soils in low lands. The Oak easily holds its own against the Hornbeam.

When Oak is mixed with Silver Fir it requires a decided start, or it will after some time be outgrown and suppressed.

Spruce is less suited for mixture with Oak; the two species have a different character and demand different conditions of locality. At first the Oak grows faster, and afterwards the Spruce. Frequently Oak becomes stag-headed when mixed with Spruce.

When grown as standards in coppice, the Oak is frequently mixed with many other species, such as Ash, Maples, Elm, Birch, Larch, or Scotch Pine.

Oak coppice woods grown for the sake of the bark should be pure, so as to obtain the highest possible returns; if grown for other purposes they are frequently mixed with a variety of other species, such as Beech, Hornbeam, Ash, Elm, Maple, Sweet Chestnut, Birch, Hazel, Willow, Aspen.

#### *g. Sylvicultural Systems.*

Oak is equally well adapted for high forest or coppice, and for combinations of the two; the sessile Oak is perhaps a little more suited for coppice than the pedunculate species, because it is somewhat less exacting as regards fertility of soil, reproduces better from the stool, and the bark is easier to peel. A mixture of Oak in Beech woods is the best system for the production of superior Oak trees, also high forest with a soil-

protection wood, or two-storied high forest; if trees of large diameter and moderate height are wanted, standards in coppice woods.

*h. Formation of Woods.*

The Oak is principally regenerated by sowing and planting or by stool shoots in coppice, less frequently by natural regeneration by seed.

The acorns ripen in October (pedunculate early, sessile late), and fall shortly afterwards; they retain their germinating power for about six months. Good seed should show a germinating per-centage of not less than 65 per cent. One pound contains about 130 acorns of the pedunculate species, and somewhat more of the sessile Oak.

Direct sowings are made in autumn or spring; as to their merits see the remarks under Beech (p. 234). Spring sowings sprout after 4 to 6 weeks. About 550 pounds of acorns are required per acre for broadcast sowings; they are covered with about  $1\frac{1}{2}$  inches of soil.

Sowings in nurseries are generally made in drills, or the acorns are placed flush on the seed-bed in rows, and covered with  $1\frac{1}{2}$  inches of soil. The seedlings should be pricked out when one year old; they are ready for putting out after two years more; frequently older plants are used, which may have been pricked out a second time. The plants stand pruning well, both on the crown and roots. They are generally planted out in pits.

In regenerating Oak woods naturally by seed, the acorns

must frequently be brought artificially into the ground, either by driving herds of swine through the woods, or lightly hoeing the soil after the acorns have fallen. The seed trees are removed quickly, generally within a few years after the young crop has come up; otherwise the latter is likely to suffer from the shade of the mother trees.

*i. Tending.*

*Fertility of the Soil.*—As already stated, pure Oak high forest is rarely capable of preserving the fertility of the soil, hence such woods must be underplanted with shade-bearing dense-crowned species.

*External dangers* are on the whole not great. Young Oak suffers from late frost, but such damage heals easily, owing to the great reproductive power of the tree. It is very storm-firm. Snow and rime only break the branches, especially the lower ones.

Cattle and game nibble Oak freely; red deer and mice to some extent peel the bark. Oak supports more insects than any other tree. Kaltenbach, in an incomplete list, enumerates over 500 species. The acorns may be destroyed by weevils (*Balaninus*) or by wire-worm after planting; the trees are frequently defoliated by *Tortrix viridana*, *Liparis monacha*, and in S. Europe by *Cnethocampa processionea*; also by cock-chafers. Many weevils eat the buds. The bark is injured and sickly trees are killed by species of *Agrilus* and by *Scolytus intricatus*. The timber may be rendered valueless by the boring of *Cossus* larvæ, or those of *Longicornia*, especially in Central Europe, by *Cerambyx heros*. Many gall-wasps attack the Oak,

chiefly ill-grown, pollarded, or hedgerow trees. They are only harmful in nurseries.

The Mistletoe (*Loranthus europæus*) is found on the branches. Fungi are numerous on Oak, but the forester need not be frightened by them. Cancer appears on the stem, but it seems as yet doubtful whether it is produced by a fungus (*Nectria ditissima*) or frost. White-rot in the stem is produced by *Polyporus igniarius* and *Hydnum diversidens*; red-rot with white strips by *Stereum hirsutum*; red-rot with white spots by *Telephora Perdix*; red, white and yellow rot intermixed in elongated places by *Polyporus dryadeus*. Seedlings and young plants are dried up by *Rosellinia quercina*.

*Pruning.*—The Oak stands pruning well, but care should be taken to remove the branches while small, so that the wounds may be quickly closed.

*Thinning.*—As pure Oak woods are generally underplanted, the thinnings should be as follows:—During youth, say up to the age of 30 years, there should be only very light thinnings or none at all. Cleanings may be made to remove any undesirable species threatening the Oak, such as Birch, Willows, and Aspen. After this early period the thinnings should gradually become heavy, so as to develop a limited number of fine trees which are to form the final crop, assisted by an underwood to shelter the soil.

#### 4. ASH = *Fraxinus excelsior* (L.).

##### a. Utility.

The Ash yields an excellent timber, hard and heavy, specific gravity when air-dried = .75, tough and durable.



It is used for a great variety of purposes, by the joiner, carpenter, wheelwright, sievewright, basket maker, &c. It also yields a very good fuel. The leaves are good fodder.

*b. Distribution.*

Europe up to 63° latitude, also North Africa. It is indigenous in Great Britain and Ireland, going up to 1350 feet in Yorkshire, and to 4000 feet in the Alps.

*c. Locality.*

*Climate.*—Ash does not require much heat, but it is very tender against late frost, and also drought. It is light-demanding, standing next to Oak, but it bears somewhat more shade in youth. It likes moist air, and is storm-firm.

*Soil.*—Ash requires a deep, porous, moist and fertile soil. It is chiefly found in low lands, near rivers, and in the bottom of mountain valleys. Good loamy soils, with some lime, also marls, suit it best; it avoids sandy and acid soils.

*d. Shape and Development.*

The Ash has a straight stem, which divides into branches at about half its height; it is specially liable to fork. The crown is of moderate extent, and thin during the first half of the tree's life; afterwards it becomes broader. The root-system is extensive and deep-going, with a tap-root; the tree requires much growing space below ground. It is a rapid height-grower, especially during the first half of its life; during the second half it is liable to be outgrown by both Beech and Oak. It reaches a height up to about 110 feet.

Ash does not attain a very large diameter. Its volume-growth is smaller than that of Oak.

The upper age-limit of Ash may be placed at 300 years.

*e. Reproductive Power.*

The tree commences producing full crops of seed when about 40 years old; they are somewhat light, and occur about every other year.\* The reproduction by seed is on the whole moderately good.

If coppiced, the Ash reproduces well from the stool; chiefly by stool-shoots, but also by suckers. It also reproduces well when pollarded.

*f. Character and Composition of Woods.*

Ash appears in pure woods, but owing to its light foliage it is not suited to be so grown except in very favourable localities. It is much better adapted for mixing with other species, especially Beech, and also Hornbeam. It is frequently found mixed with Oak, Alder, Maple, Elm, Lime, Sweet Chestnut, Willow, Poplar and Hazel, especially in coppice with standards, or coppice only. Owing to its quick growth, it generally holds its own against the other species.

*g. Sylvicultural Systems.*

Ash is treated as high forest, coppice, pollards, and as standards in coppice. If found pure in high forest, it requires underplanting, like the Oak.

\* On page 173 of Volume I., Ash has, by an oversight, been included amongst the trees which produce full crops of seed every 3—5 years.

*h. Formation of Woods.*

Ash woods are generally formed by planting, rarely by direct sowing.

The seed ripens in October and falls during winter until spring; it retains its germinating power up to three years. Of good seed 65 per cent. should germinate. About 6,500 clean seeds go to the pound.

The seed germinates in the second spring, and should be treated like that of Hornbeam (page 240).

For direct sowings about 35 pounds of seed per acre are required. The seed should receive a covering of about three-quarters of an inch.

In nurseries the seed is generally sown in drills about March, or April, of the second year, after it has been lying imbedded in sand for 16 or 17 months; the seedlings will be ready for pricking out in the following spring, and they may remain one, two, or more years in the nursery lines according to the required class of plants. It may be mentioned that the development of a suitable crown and stem can be regulated at this period, by pinching off unnecessary buds and young shoots. Ash is usually planted in pits.

*i. Tending.*

Young plants are very liable to suffer from late and early frosts, hence some shelter is useful; this, however, cannot be heavy, as the Ash is light-demanding. They suffer much from browsing by cattle and deer, unless protected by a fence. Deer and mice also peel the stem.

Insects and fungi are not very formidable. The leaves of the Ash tree are rarely injured except by

*Cheimatobia brumata*, and in Central Europe by the blister-beetle, *Lytta vesicatoria*. The shoots are sometimes much stunted by the larvæ of a Tineid moth, *Prays curtisella*. The bark is sought and badly gnawed by the hornet. The *Cossidæ* readily attack it; *Zeuzera* preferring the saplings to any other food plant. The bark-beetles, *Hylesinus fraxini* and *crenatus* kill sickly trees; the former also attacks the upper branches of healthy trees and kills them in a few years by working down the stem.

Cancerous spots in the bark may be caused by *Nectria ditissima*.

The thinnings of Ash woods should be such as to enable the tree to lay on diameter increment, in other words to give it a liberal growing space at all times, and especially with advancing age.

### 5. ELM = *Ulmus* (L.).

The following two species will be noticed here:—

- (1.) The Common Elm = *Ulmus campestris*, Sm.
- (2.) The Scotch, Wych or Mountain Elm = *Ulmus montana*, Sm.

#### a. Utility.

Elm yields a coarse timber which is hard, moderately heavy, difficult to split, very durable, even when exposed to become alternately wet and dry. Specific gravity of air-dried Common Elm = .69. It is used for a great variety of purposes in rural districts, by the carpenter, joiner, wheelwright, turner, boat-builder, and others. It yields a good firewood, and the leaves are good fodder. The ashes yield excellent potash.

*b. Distribution.*

The *Common Elm*.—Central and South Europe, North Africa and Siberia; goes up to 4,000 feet in the Alps. It is found in England, up to an elevation of 1,500 feet in Derbyshire, also in Ireland, rarer in Scotland. Introduced into England, where it does not, as a rule, bear fertile seed.

*Wych Elm*.—Europe and Siberia. Indigenous in Britain, going north to Sutherland, also in Ireland. Ascends to 1,300 feet in Yorkshire.

*c. Locality.*

*Climate*.—Elm requires a mild climate, but is not sensitive to late frost. It is a light-demanding tree, but less so than Oak and Ash. It is storm-firm.

*Soil*.—Elm demands a deep, fairly porous, moist and fertile soil to do well; hence it is mostly found on alluvial soils in low lands and valleys. The Wych Elm is somewhat less exacting than the Common Elm.

*d. Shape and Development.*

The Elm divides into branches at about half its height. The crown of the Common Elm is narrow and tends upwards; the Wych Elm has a broader crown. The root-system consists of a tap-root with numerous side roots; at an advanced age the system becomes comparatively shallower. It grows quicker than Oak, but rather slower than Ash, and reaches an ultimate height of about 110 feet; the Common Elm under specially favourable

conditions up to 125 feet. It attains a considerable diameter.\* It is a long-lived tree, reaching an age of 500 or even more years.

*e. Reproductive Power.*

The Elm commences producing seed plentifully at an age of about 40 years. The crops are heavy and occur about every 2 or 3 years; in Britain the seed of the Common Elm very rarely ripens. On the whole the reproductive power by seed is great. Both Elms have a great reproductive power from the stool, there being stool-shoots and suckers; also reproduce well by stem shoots. Trees upwards of 40 years old when cut over still reproduce well from the stool.

*f. Character and Composition of Woods.*

Elm is not well suited for pure woods. It does much better mixed with Beech and Hornbeam; also grown with Oak, Ash, Alder, and others. It holds its own against these species, except Beech, which may outgrow it during the second half of life. If pure, Elm should be underplanted like Oak.

*g. Sylvicultural Systems.*

High forest, standards in coppice, coppice, and pollards.

*h. Formation of Woods.*

The Elm is generally planted; the plants are either raised from seed, or they consist of suckers or layers.

\* The author has seen, at Schimsheim, in Rhenish Hessen, a Common Elm tree of fourteen feet diameter measured at three feet from the ground.

As the seed of the common Elm does not ripen in Britain, it is generally propagated in the latter way in this country.

The seed ripens in May to June and falls almost immediately; it keeps its germinating power only for a short time, and must be sown at once. If 45% germinate, it is considered very good seed. There are about 70,000 seeds to the pound. In nurseries the seed is best sown broadcast and very slightly covered with fine earth, one-tenth of an inch being sufficient; it germinates after 10 to 20 days. The seedlings may be placed in nursery lines in the following spring, and they are fit to be put out after another year, though they frequently remain longer in the nursery.

The methods of obtaining layers and suckers have been shortly indicated at page 130.

#### *i. Tending.*

The Elm, being hardy and grown mixed with other species, does not require much tending. Cattle and deer do damage by browsing, but the damage is quickly healed. Insects and fungi do a moderate amount of damage. The Elm suffers from two scale-insects, *Schizoneura lanigera* and *Lecanium vagabundum*; the latter lives on the stems of saplings, destroying large patches of bark. Elms have been much injured by two bark-beetles, *Hylesinus vittatus* in Central Europe, and *Scolytus Geofroyi* (*destructor*, Ol.). The latter is exceedingly harmful to the unhealthy Elms growing near large towns. It also attacks trees in the open country, selecting weak spots, generally the extremities of old branches, at the

summit of the tree, and working down the trunk year by year. Of *fungi* nothing need be mentioned.

Elm generally holds its own against the species with which it is usually mixed, but from middle age upwards it must be given a liberal growing space by thinning away the other species to a sufficient extent.

## 6. SWEET CHESTNUT = *Castanea vesca* (Gærtn.).

### *a. Utility.*

The Chestnut yields a fairly hard, moderately heavy timber, specific gravity, air-dried, = .66, splits well, durable. Used for building, in carpentry, staves for wine-casks, vine-stakes, hop-poles, &c. It is not a very good firewood, but the charcoal is much appreciated by blacksmiths. The bark is used for tanning. The fruit is eaten.

### *b. Distribution.*

Asia, Europe, North America. In Europe it is indigenous in the south and west; introduced into Britain, where the fruit rarely ripens fully. It rises to 2,800 feet in the Alps.

In its natural home the Chestnut is a tree of the lower hills and mountains, preferring northern and eastern aspects, rarely found in the low lands.

### *c. Locality.*

*Climate.*—Requires a mild climate, is tender against late and early frost and also severe winter cold; drought also does not suit it. Chestnut is a light-demanding tree, but less so than Oak. During youth it stands



some shade, so that it thrives under Scotch Pine woods. Later on in life it becomes more light-demanding. It is storm-firm.

*Soil.*—Chestnut likes a deep, porous, fresh and fertile soil. It can grow in rather dry soil if deep, but avoids wet localities. A loamy sand suits it best; it does not like heavy soil, and avoids calcareous soils.

\

*d. Shape and Development.*

Chestnut has a straight stem, which however branches at a moderate height. If space permits, it produces a broad crown, which is fairly dense. The root-system is deep-going, resembling that of the Oak.

The height-growth during youth is somewhat more rapid than that of Oak, but it does not reach the same height as the latter. It attains a very large diameter.\* It is a long-lived tree, reaching an age of more than 500 years.

*e. Reproductive Power.*

Chestnut comes into full bearing at the age of about 50 years. Full seed-years occur every 2 or 3 years, though some seed is produced almost annually.

The reproductive power from the stool is very great; even the stools of trees up to 100 years old, when cut over, yield shoots; the stools last a long time.

\* A Chestnut tree on Mount Etna is reported to have a girth of about 200 feet (Döbner-Nobbe).

*f. Character and Composition of Woods.*

The Chestnut is not very suitable for growing in pure woods as high forest, as it opens out about the same time as the Oak, though not to the same extent. Such woods require under-planting. It is, however, grown pure as coppice. It does well in mixture with Beech and Oak as high forest; in coppice it is grown mixed with many species, as Beech, Oak, Ash, Elm, Maple, Lime, Birch, Hazel, Willow, Aspen, &c.

*g. Sylvicultural Systems.*

High forest, standards in coppice, but chiefly coppice. In Southern Europe much grown as a fruit tree in open woods. As high forest it is treated under a rotation generally not exceeding 100 years, as coppice under one of 5 to 30 years, according to the size of the required material.

*h. Formation of Woods.*

Direct sowing is done, but chiefly planting. The chestnuts ripen in October and fall immediately. They retain their germinating power for about six months. Of good chestnuts not less than 60% should germinate. One pound contains about 115 chestnuts.

Direct sowings should be made in spring, as the chestnuts are liable to be eaten by mice if sown in autumn; they should not be sown too early, as the young seedlings are tender against late frosts. The chestnuts should be covered with about  $1\frac{1}{2}$  inches of soil; they germinate after five or six weeks.

The treatment of Chestnut in nurseries is similar to that described for Oak (page 246).

*i. Tending.*

Young Chestnuts must be protected against late and early frosts, either by sheltering them artificially, or by raising them in sheltered localities. They also require protection against cattle and deer, which browse them.

Damage by insects and fungi is not of much importance. The only part of the Sweet Chestnut liable, as a rule, to damage by insects is the fruit, the crop of which may be much lessened by the internal-feeding larvæ of species of *Carpocapsidæ* among the *Tortrices*.

The Chestnut stands pruning well.

Thinnings are done as in the case of Oak.

7. MAPLE = *Acer* (L.).

The following two species are grown as forest trees in Britain :—

- (1.) The Great Maple, or Sycamore = *Acer Pseudo-platanus*, L.
- (2.) The Norway Maple = *Acer platanoides*, L.

*a. Utility.*

The white or yellowish-white timber of the two Maples is moderately heavy (Sycamore, sp. gravity, air-dried, = .66, Norway Maple = .68), hard, fairly durable under cover, but of short duration in the open. It has great heating power, but is not an agreeable fuel for

domestic purposes. It is used by the joiner; for finer wheelwright's work; for carving; for mathematical instruments; and a variety of other purposes. The leaves yield good fodder.

The timber of the Sycamore is somewhat preferred to that of the Norway Maple.

*b. Distribution.*

*Sycamore.*—Middle Europe and Western Asia. Goes higher in mountains than the Beech; up to 5000 feet in the Alps. Probably introduced into Britain.

*Norway Maple.*—Europe; goes further north than the Sycamore, up to 62° of latitude; it does not go in mountains as high as the Sycamore; to about 4000 feet in the Alps. Not indigenous in Britain.

*c. Locality.*

*Climate.*—The Maple generally makes small demands on the temperature, but it suffers a good deal from late frosts, and also from excessive heat; it is hardy as regards winter cold. As regards light-requirement, it stands about half-way between light-demanders and shade-bearers. Maple is a storm-firm tree. The Norway Maple is specially adapted for cultivation by the seaside; it is somewhat more a tree of the plain than the Sycamore; it also suffers somewhat less from late frosts.

*Soil.*—Maple requires a deep, fresh and fertile soil; Norway Maple can do with somewhat less fertile soil than Sycamore, also with less moisture, but stands a higher degree of it than the other Maple.

*d. Shape and Development.*

The stem of the Maple, though straight, divides rather low down into branches; it forms large oval crowns if grown in the open, which are of moderate density. In crowded woods Maple develops a tall, cylindrical stem, with a small crown restricted to the upper part of the stem. The root-system is deep-going. Maple at first shows quick height-growth, but it falls off comparatively early, so that it is liable to be passed by Beech, though it may ultimately reach the same height. Both Maples reach a large diameter, and a great age.

*e. Reproductive Power.*

Sycamore produces full crops of seed after the age of 40 years, Norway Maple a few years earlier; they are not very heavy, and occur about every other year; on the whole the reproductive power by seed is good. That from the stool is moderate, and the stools do not last long.

*f. Character and Composition of Woods.*

Though Maple is fairly well adapted for pure woods, it is generally mixed with other species, especially Beech, also Oak, and even Conifers.

*g. Sylvicultural Systems.*

High forest, standards in coppice, and coppice.

*h. Formation of Woods.*

Maple is generally planted, though it reproduces naturally wherever it has a chance.

The seed ripens in September to October, and falls in October, and into the winter months. The germinating power disappears rapidly after the following spring. Good seed should show a germinating percentage of at least 55. One pound of seed of Sycamore contains about 5000 seeds, of Norway Maple somewhat more.

The best plan consists in bedding the seed, as in the case of Ash and Hornbeam, sowing it in drills in the spring, as soon as it shows signs of germinating; the seed should be covered at least to a depth of  $\frac{2}{3}$  of an inch, but  $1\frac{1}{4}$  inch is not too much. The cotyledons appear in that case after about two weeks, if the weather is warm. Seed kept over winter and sown in spring germinates after 4 to 6 weeks. The seedlings may be removed into nursery lines when one year old.

Maple is generally planted out in pits.

#### *i. Tending.*

Maple, while young, requires some protection against late frosts.

Maple is browsed by deer, also sometimes peeled, but it is little injured by insects. The seedlings are sometimes destroyed by wireworm. The roots of saplings may be attacked by chafer-grubs, whose imagos may defoliate the tree, as well as the larvæ of *Acronycta aceris*. *Zeuzera æsculi* will kill young trees.

Fungi are of little importance. The black spots on the leaves are due to *Rhytisma acerina*. *Phytophthora omnivora* sometimes kills young seedlings.

Mistletoe is found on Maple.

Pruning should be avoided.

*Thinnings.*—The Maple should be given an ample growing space when the height-growth begins to fall off.

## 8. COMMON ALDER = *Alnus glutinosa* (Gærtn.).

### *a. Utility.*

The specific gravity of air-dried wood is, on an average, = .53. The timber is soft, splits easily, does not last in the open, but well under water, and is used accordingly; it is also used for herring-barrel staves, for cigar boxes, and cooperage. It yields an inferior fuel, but a charcoal well adapted for the manufacture of gunpowder. For Schulze's powder the wood is used without first converting it into charcoal. The bark is used for tanning.

### *b. Distribution.*

It is found in most parts of Europe, almost up to 62° of latitude, in Northern Africa, and in Western and Northern Asia. It is indigenous in Great Britain and Ireland. It goes up to 1600 feet in the Scotch Highlands, and to about 4000 in the Alps.

### *c. Locality.*

*Climate.*—Alder requires little warmth, is fairly hardy against frost, but very sensitive to drought. It is a light-demanding tree, standing about on a par with Elm, but somewhat below Oak. It requires moist air, and suffers from snow and rime, which break the branches.

*Soil.*—Alder requires a porous, moist soil of at least middling depth. Moisture is specially required in the subsoil. Although it requires more moisture than the commoner forest trees, it does not thrive in stagnant water. It is at least moderately exacting as regards the chemical composition of the soil. It does best on humus-rich sandy loam, and thrives even on peat soil; cold clay or dry sand does not suit it. Alder is principally found along river banks in the low lands, and at the bottom of mountain valleys. It does not seem to be particular about aspect.

*d. Shape and Development.*

Alder develops a straight stem, which divides only in the upper part; the branches are of moderate size, with a rather thin foliage. The root-system consists of a number of deep-going side-roots, which branch in the subsoil and end in numerous fine rootlets.

It is a quick grower, but rarely reaches a height of 75 feet, generally considerably less; it lives, as a rule, to an age not exceeding 100 years, only exceptionally longer.

*e. Reproductive Power.*

Alder begins to seed fully at the age of about 25 years; the crops of seed are heavy, and they occur about every three years. On the whole the energy of reproduction by seed is moderate. The reproductive power from the stool is strong and enduring; the tree chiefly produces root-suckers.



*f. Character and Composition of Woods.*

Pure woods of Alder are found in moist or wet localities, where a sheltering of the ground is either not essential or even undesirable. It is also found in mixture with other species, especially with Ash, Birch, Elm, or Oak, generally occupying the moister parts of the woods.

*g. Sylvicultural Systems.*

Alder is mostly treated as coppice, either by itself or as underwood under standards. It is also found in high forest; generally in mixture with other species, in that case rarely pure.

As coppice it is treated under a rotation up to 40 years; in high forest under one of 50 to 80 years.

*h. Formation of Woods.*

Alder woods are generally formed by planting, and then either coppiced, or, if treated as high forest, replanted. The plants are sometimes raised from cuttings and layers, but generally from seed.

The seed ripens in October, and falls from November until spring. It maintains its germinating power for about one year; if 35 per cent. germinate, it is considered good seed, but frequently a much smaller percentage is fit to germinate. One pound contains about 300,000 seeds.

For direct sowings about 15 pounds of seed would be required per acre, but such sowings are rarely made; the seeds should receive a light covering of not more

than one-third of an inch, and they germinate, if sown in spring, after 4 to 6 weeks.

In nurseries a moist part should be chosen for the seed beds; at any rate they must be kept moist after sowing. The seed is sown broadcast. When one year old, the seedlings may be pricked out, and left one or two years in the nursery lines.

The planting is mostly done in pits.

#### *i. Tending.*

Alder does not require much tending. When quite young it is liable to suffer from frost lifting, owing to the moist condition of the soil where it is usually grown. This can be prevented by covering the space between the plants; any plants actually lifted must be promptly put back into the ground.

Considerable danger may threaten Alder from the drying up of the subsoil owing to a change in the level of the ground water. Such danger must, as far as practicable, be avoided, by preventing the water from being drained away. At the same time inundation may do much damage, especially if it occurs after a wood has been coppiced, and if the water covers the stools, or if sheets of ice form over young plantations.

Insects and fungi do little damage. The foliage of Alder may be injured by *Tortrix* larvæ, or by the plant-beetles, *Agelastica alni* and *Lina œnea*, both uncommon in England. The bark of young Alders is attacked by a weevil, *Cryptorrhynchus lapathi*, which breeds in their stems. Older trees are bored by the *Cossidæ* and one or two *Sesias*.

Of fungi *Nectria ditissima* may cause cancerous formations, and *Polyporus sulphureus* red-rot in the stem. *Exoascus borealis* causes witch's broom, and several other species of this genus are found on the leaves and flowers.

## 9. BIRCH = *Betula alba* (L.).

### a. Utility.

The timber is fairly heavy, specific gravity of air-dried wood = .64, moderately hard, does not split well, of small durability; good firewood, which is also converted into charcoal for the manufacture of gunpowder. The timber is used by joiners, wheelwrights, coarse carvings; in Britain extensively used for bobbins, also for herring barrels. The branches and still more young shoots and trees are used for withes, brooms, &c. The bark is used for tanning and the manufacture of small vessels and boxes.

### b. Distribution.

It is chiefly found in Northern and Eastern Europe; also in Northern Asia and in North America (a variety). In Europe between 47° and 70° latitude. It is indigenous in Great Britain and Ireland. It is a tree of the lowlands, lower hills, and even mountains. It grows up to 2,500 feet in Scotland, in the Alps to over 5,000 feet.

### c. Locality.

*Climate.*—It requires but a low temperature, is frost-hardy, and not particular as regards heat. It is highly light-demanding, almost as much as Larch. It likes moist air. Thrown to some extent by storms. Suffers

somewhat from snow and rime. It prefers south or west aspects.

*Soil.*—Birch requires only a shallow soil, with a moderate amount of moisture; it is not exacting as regards mineral composition. Although loamy sand suits it best, it accommodates itself to all sorts of other soils. It is found on soils ranging from poor dry sandy soil to swampy ground, but avoids stiff clay and calcareous soils.

*d. Shape and Development.*

The stem is generally wavy or undulating, and divided into branches in the upper part. The crown assumes an elliptic shape, and is thin. The branches are often drooping. The root-system is weak and shallow.

It grows quickly from the beginning, but rarely reaches a height of 100 feet, generally not beyond 70 or 80 feet. Its volume growth is smaller than that of most other important forest trees. Its life seldom exceeds 100 years.

*e. Reproductive Power.*

Birch begins producing full crops of seed when about 25 years old; they recur every two or three years and sometimes annually, and are heavy. On the whole, the reproductive power by seed is very great. The light seed is easily carried about, and young Birch springs up wherever there is room for it, owing to the accommodating power of the species.

The reproductive power from the stool is weak; the shoots spring chiefly from the root neck; the stools are liable to die off after two or three rotations.

*f. Character and Composition of Woods.*

Owing to its thin crown and great light-requirement, Birch is not well suited for pure woods; nevertheless it appears pure over extensive tracts in Northern Europe, (Russia, Scandinavia, and Britain), owing to its great reproductive power and accommodating character, which enables it to grow in localities where other species would not thrive, or where it outstrips them. In such localities its preservation is justified.

In other localities it should be mixed with species with dense crowns, such as Beech. It is not so well suited for mixture with conifers, as it injures them by the whip-like action of its slender branches.

*g. Sylvicultural Systems.*

High forest, also standards in coppice; little suited for coppice. Excellent shelter wood over a tender species; planted in shelter belts and wind breaks. Useful for filling blanks in existing woods. It is treated under a rotation of 40 to 60 years in high forest, and of 15 to 20 years as coppice; for the production of withes it may be cut over after 3 to 5 years, according to circumstances.

*h. Formation of Woods.*

They can be formed artificially or naturally. The seed ripens from the end of August to October, according to locality, and commences falling soon afterwards up to February. It maintains its germinating power for six to twelve months. It is considered good seed if 20

per cent. of it germinate. One pound of clean seed contains something like 800,000 seeds.

Direct sowing is rarely done. Broadcast sowings would require about 30 pounds of seed per acre, which should be very thinly covered, only about one-eighth of an inch. The seed germinates after 2 to 3 weeks. Seed which has ripened early in the autumn may germinate in the same year; otherwise it lies dormant till spring.

In nurseries the seed is sown broadcast and covered by sprinkling a little earth over it. The one-year-old seedlings may be pricked out and left for one or two years in the nursery lines, according to requirements. On the continent one or two-year-old plants are used for planting.

Birch can easily be regenerated naturally under a very small number of mother trees. Generally it appears where it has a chance of springing up, and the forester has more to fight against it than to favour it.

#### *i. Tending.*

*Fertility of Soil.*—Early opening out and a thin crown do not enable the Birch to act beneficially upon the soil; hence it should not be grown pure, except on localities where more valuable trees will not thrive.

*External Dangers.*—Birch being very hardy, requires no tending against climatic influences; the damage done by snow, rime, and storms, is moderate. It is less nibbled by cattle and deer than almost any other broad-leaved tree. It is attacked by mistletoe.

*Insects.*—The leaves support a very large number of larvæ, which, as a rule, are not gregarious. Injury is

occasionally caused by the following species:—*Liparis dispar*, and *monacha*; *Eriogaster lanestris*, *Pygæra bucephala*. *Rhynchites betulæ* and its allies cut and roll up the leaves. The young stems are injured or killed by the larvæ of species of *Agrilus* and *Sesia*, and by *Zeuzera æsculi*. The goat-moth, *Cossus*, lives in older trees, which are also liable in some localities in N. Europe to suffer from the burrows of a bark-beetle, *Scolytus Ratzeburgi*.

Birch has no serious enemies amongst fungi. *Exoascus turgidus* produces witch's broom; *Polyporus betulinus*, red-rot; *Polyporus lævigatus*, white-rot.

Birch is rarely pruned. Thinnings are regulated naturally, as the weaker individuals are speedily suppressed by a moderate number of dominant trees per acre. In mixed woods the more valuable species require, during youth, to be protected against the Birch, as the latter generally grows quicker.

#### 10. WILLOW = *Salix* (Tournef.).

Of the numerous species of Willow only the following four need be mentioned here:—

- (a.) Common Sallow, or Goat Willow = *Salix Caprea*, L.
- (b.) White Willow = *Salix alba*, L.
- (c.) Crack Willow, or Withy = *Salix fragilis*, L.
- (d.) Osier = *Salix viminalis*, L.

The Willows yield a soft light timber which is little prized, except for some special purpose, as for cricket-bats; their principal value consists in yielding withes and materials for basket-work, cask-hoops, &c. The wood is not good fuel, but may be converted into charcoal for

the manufacture of gunpowder. The bark is used for tanning. The Osier yields the largest quantity of material for basket-work, but various other species are grown for the same purpose.

*a. Common Sallow.*

The Sallow occurs all over Europe, North and West Asia, Himalayas. It is found in Great Britain, up to Inverness, and in Ireland. It ascends to 2,000 feet in the Highlands and to about 5,000 feet in the Alps.

It is a tree of the low lands and outer hills, prefers a fresh soil, but can do even with dry soil; appears on calcareous soils. The tree is little exacting in respect of climate, and hardy. It is light-demanding, of quick growth, and has a thin crown which cannot do justice to the soil.

It is treated as coppice wood, under a rotation of 10 to 15 years, having a good reproductive power from the stool, yields only fire-wood, withes and fascine wood. It appears plentifully in high forest, but is generally removed in the cleanings and early thinnings.

The seed of this Willow ripens in May or June, and must be sown at once, as it does not preserve its germinating power. Sowings of Willow are, however, never made in Sylviculture. The tree is propagated by cuttings. These are cut, from a foot in length and upwards, from the previous year's wood, though older wood may also be used. The cuttings may be placed into a nursery for one year, or planted out at once. Unless the soil is very



loose, holes should be made, into which the cuttings are planted. The area should be kept clear of weeds, and the surface soil loosened between the cuttings.

It is nibbled by cattle and deer, and peeled by mice.

*b. White Willow.*

Europe, North Africa, North and West Asia, North-west India. It is planted in all parts of Great Britain and Ireland, generally along the banks of rivers. It likes fresh loose soil, especially of a loamy nature, but is not very exacting; is light-demanding, grows rapidly, has a thin crown, and is hardy.

The White Willow is best adapted for pollarding (topping), less suited for coppice. It also appears in high forest amongst other species. As pollards, it is worked under a rotation of three to six years; the material is used for fascines, cask-hoops and basket work.

It is propagated by cuttings, which may be five and six feet long, so as to produce a tree in the shortest possible time.

As regards animals, see *S. Caprea*.

*c. Crack Willow.*

Europe, North and West Asia. Planted along river banks and low land generally; likes moist or wet soil, especially loamy sands; light-demanding, thin foliage; grows rapidly; hardy, but suffers from snow and rime; good power of reproduction by shoots.

It is suited for pollarding and coppice, and is treated like the White Willow; the shoots are not suited for basket work, as they are liable to crack.

*d. Osier.*

Russia, North Asia; cultivated throughout Europe. It is extensively grown in osier beds, which are generally established along river banks and other low-lying parts of the country, on loose, moist, sandy soil; it is, however, exacting as regards general fertility of the soil. It is light-demanding, with a thin crown; grows rapidly; fairly hardy, but suffers sometimes from frost, insects and fungi.

The Osier is treated as coppice. The rotation depends on the desired material, and ranges from one to six and even eight years. Material for fine basket-work is obtained by cutting annually. Reproduction is powerful, but the stools do not last for more than perhaps 15 years, and frequently not so long.

The Osier is propagated by cuttings as described for the Common Sallow. In England the cuttings consist frequently of whole shoots, of which only about one foot of the lower end is inserted into the ground.

---

Willows generally are injured by numerous insects, which are common to most species. The wood, chiefly of *Salix alba*, is much attacked by *Aromia moschata*, *Lamia textor*, and other Longicorn beetles, and by the goat-moth, *Cossus*. The leaves are attacked by various *Bombyces*, as *Liparis salicis* and *Pygæra bucephala*; by sawfly larvæ, and by plant beetles, especially the species of *Phratora* and *Galeruca*. These are very injurious to *Salix viminalis*, as are the leaf-binding larvæ of *Earias chlorana*. The twigs are injured by *Sesiidæ* and by gall-

gnats (*Cecidomyidæ*). A weevil, *Cryptorrhynchus lapathi*, destroys the bark and shoots, especially of *S. viminalis*.

Of *fungi*, several species of *Melampsora* produce a rust which causes the leaves to die. *Polyporus sulphureus* produces red-rot in the wood.

## 11. POPLAR = *Populus* (Tournef.).

The following three species must be mentioned :—

(a.) Aspen = *Populus tremula*, L.

(b.) White Poplar = *Populus alba*, L.

(c.) Black Poplar = *Populus nigra*, L.

### a. Aspen.

#### i. UTILITY.

The Aspen yields a soft light timber, of small durability in the open; average specific gravity .49; heating power small.

It is used sometimes under cover for buildings, for packing- and cigar-cases, rough cooperage, inner work of carriages, manufacture of matches, and of paper. The charcoal is used in the manufacture of gunpowder. The bark is used in tanning and dyeing (for the latter purpose also the leaves).

#### ii. DISTRIBUTION.

Europe, North Africa, North Asia. Indigenous in Great Britain and Ireland. Ascends to 1,600 feet in Yorkshire; to 4,000 feet in the Tyrol.

## iii. LOCALITY.

*Climate.*—Hardy against frost and drought. Highly light-demanding, likes moist air, subject to be thrown by storms.

*Soil.*—Grows almost anywhere, except on very poor dry sand; moist loamy sand, rich in humus, suits it best. It is generally very accommodating.

## iv. SHAPE AND DEVELOPMENT.

It develops a tall stem with a thin crown, reaching a maximum height of about 110 feet. It is of quick growth and short-lived, reaching rarely an age of more than 100 years.

## v. REPRODUCTIVE POWER.

Great by seed; sends out numerous root-suckers.

## vi. CHARACTER AND COMPOSITION OF WOODS, SYLVICULTURAL SYSTEMS.

Rarely pure. Generally appears in high forest in mixture with other species, also occasionally as standards in coppice. Generally cut out in thinnings, as it becomes ripe in about 50 to 60 years, or threatens to injure the more valuable species.

## vii. FORMATION OF WOODS, DANGERS, TENDING.

Aspen is generally propagated by root-suckers, sometimes by layers; cuttings strike less well. It springs up readily from seed in open spaces, and in young woods of other species. The young trees are nibbled by deer, also peeled. Subject to much injury by insects. Requires no special tending.

*b. White Poplar.*

Europe, North Africa, North and West Asia, N. W. Himalayas. Indigenous in Great Britain and Ireland. Timber light, soft, specific gravity =  $\cdot 48$ ; used for similar purposes as that of Aspen,<sup>1</sup> but more valued.

Found in low lands and river valleys, likes deep loose moist soil, more exacting than Aspen. Growth quick, stem straight; is light-demanding, foliage somewhat denser than that of Aspen. Reproductive power good, especially root-suckers.

Best propagated by root-suckers, less well by cuttings. Treated as pollards, less suited for coppice. Occasionally standards in coppice.

*c. Black Poplar.*

Europe, North Asia; not indigenous in Britain, but planted.

Timber light, soft; specific gravity =  $\cdot 45$ ; most valued next to that of White Poplar, and used for similar purposes.

Appears in low lands and river valleys. Thrives on any soil, if loose and moist; does not like heavy soils. Grows rapidly, developing a straight stem, light-demanding, hardy.

Reproductive power good by stool-shoots and root-suckers. Best propagated by cuttings of various length. Treated as pollards, sometimes standards in coppice.

*Insects injurious to Poplars generally:—*

The leaves of young Poplars of all species are much devoured by larvæ, which are not gregarious, except

those of *Dicranura* and *Liparis salicis*. The plant beetles, *Lina populi* and *tremulæ* (an Aspen feeder), also attack them. A Longicorn beetle, *Saperda populnea*, breeds in the twigs of young Aspens, causing gall-like swellings and crippling the growth of the plant. Its congener, *Saperda carcharias*, breeds in the stems, chiefly of Black Poplar, from 5 to 20 years old, and is a great hindrance in many places to growing the tree. Various clear-wing moths, especially *Sesia apiformis*, and the goat-moth, *Cossus*, feed in the wood, often in company with *Saperda*.

Of *fungi*, *Melampsora* species produce a rust on the leaves.

The Mistletoe is frequently found on Poplars.

## 12. LIME-TREE OR LINDEN = *Tilia* (L.).

Two species of Lime-tree have to be mentioned :—

- (1.) Small-leaved Lime-tree = *Tilia parvifolia*, Ehrh.
- (2.) Broad-leaved Lime-tree = *Tilia grandifolia*, Ehrh.

The former is the more important forest tree. An intermediate species is *Tilia intermedia*, D.C., or *Tilia europæa*, L., in Britain called the Common Lime-tree.

### a. Utility.

The wood of the Lime-tree is very light and soft, little durable, and of small heating power. Specific gravity about .45.

The timber is not fit for building purposes, but used for tool-handles, by joiners and coach builders, for

carving, piano sounding-boards, cigar-boxes, and for paper manufacture; young shoots are used for withes. The charcoal is used as crayons and for the manufacture of gunpowder. The bark yields bast for ropes, mats, packing, &c. The flowers yield a medicinal tea.

The timber of the small-leaved species is somewhat denser than that of the broad-leaved Lime-tree.

*b. Distribution.*

The small-leaved species occurs in Europe from the 62° of latitude southwards, North and West Asia; goes up to 3,300 feet in the Tyrol. The broad-leaved species is indigenous in Middle Europe and West Asia; goes up to 2,800 feet in the Tyrol.

Neither species is indigenous in Britain.

*c. Locality.*

*Climate.*—The Lime-tree is frost-tender, and still more sensitive against drought. It is by some considered a light-demander, by others a shade-bearer; practically it occupies a middle position in this respect. It is fairly storm-firm.

*Soil.*—A deep, thoroughly fresh if not moist, fertile soil. The small-leaved Lime-tree is somewhat less exacting as regards both climate and soil.

*d. Shape and Development.*

When grown in the open, the Lime-tree forms a fairly tall tree with side branches coming low down the stem. In crowded woods it develops a tall cylindrical stem, with the crown reduced to its upper part. The

root-system is deep-going. It is of quick height-growth during youth, subsequently similar to Beech, reaching about the same height. It attains a large diameter and a very great age.

*e. Reproductive Power.*

The Lime-tree commences producing full crops of seed after the age of 30 years, and they occur about every other year, showing a fair reproduction by seed. Reproduction from the stool is excellent, and the stools last a long time.

*f. Character and Composition of Woods.*

The Lime-tree is, owing to its dense foliage, well suited for pure woods, but it is not so grown, owing to the inferior quality of the timber, except in some parts of North-eastern Europe (the small-leaved species). As a rule it is found mixed with other broad-leaved trees.

*g. Sylvicultural Systems.*

High forest, and coppice either simple or under standards of other species. It makes a good soil-protection wood, and is also pollarded.

*h. Formation of Woods.*

As in Britain the seed rarely ripens, it is generally propagated by layers (see page 130), but also by seed obtained from the Continent. The seed ripens in October, the small-leaved species one to two weeks later than the other. The seed of the broad-leaved species falls in November, that of the other species later on in winter.



It retains its germinating power for two years. Of good seed 60 per cent. should germinate. One pound of seed contains about the following number of seeds:—small-leaved species = 15,000; broad-leaved species = 5,000.\* The seed germinates either in the first or second spring. If bedded in sand in the autumn and sown in spring it generally sprouts in the same year. It is easy to transplant, up to a considerable size.

*i. Tending.*

Though Lime is somewhat sensitive against late frosts, the damage caused to it in this way is as a rule moderate. Cattle like the leaves.

There are no other dangers against which the tree requires special protection. Insects and fungi are of little importance. The especial foe to the Lime is the buff-tip moth, *Pygæra bucephala*, whose gregarious larvæ often strip it bare. Other species, as *Liparis dispar* (not in England) and *Biston hirtaria*, may do the same. The leaves are sometimes destroyed by a mite, *Tetranychus telarius*, which occurs in vast numbers and sucks their juices. The cancerous places on the bark may be due to *Nectria ditissima*.

13. HAZEL = *Corylus Avellana* (L.).

*a. Utility.*

The Hazel yields a soft moderately heavy wood, which, if young, is very tough, but not durable. Specific gravity, air-dried = .63. The young wood is used for

\* According to Hess.

fascines, withes, cask-hoops, walking-sticks and other purposes. Older wood is sometimes used by joiners and sieve makers. The charcoal is used for gunpowder manufacture. The fruits are eaten and yield an oil. The leaves yield cattle fodder.

*b. Distribution.*

Europe, Northern Africa, temperate Asia. Indigenous in Britain; goes up to nearly 1,900 feet in the Highlands, and to 5,000 feet in the Alps.

*c. Locality.*

*Climate.*—Frost-hardy, does not like great heat. Stands some shade.

*Soil.*—To grow well, Hazel requires a porous, fresh soil, which need not be deep; it avoids swampy ground.

*d. Shape and Development.*

It grows quickly, is generally a shrub and sometimes a tree up to 30 feet high. Does not reach a great age, perhaps 70 to 80 years.

*e. Reproductive Power.*

It bears full crops almost every year, commencing at an age of about 10 years. The reproductive power from the stool is good, and the latter last long. The shoots start mostly below the surface.

*f. Character of Woods.*

It has a beneficial effect upon the soil.

*g. Sylvicultural Systems.*

It is generally grown as coppice, as underwood under standards, soil-protection wood under Oak, also suitable for hedges.

*h. Formation of Woods.*

From seed or by layers.

The fruits ripen in September, and fall from October onwards; they retain their germinating power for about six months. The nuts must be well covered with earth and protected against mice.

*i. Tending.*

The young plants must be protected against cattle and deer.

Hazel is not often seriously injured by insects. The caterpillars of some *Bombyces* and *Geometræ* thin the leaves occasionally. The species of *Balaninus* at times greatly reduce the crop of nuts.

The branches show cancerous places, which may be due to *Nectria ditissima*.

14. SILVER FIR = *Abies pectinata* (D.C.):

*a. Utility.*

The timber is light, specific gravity of air-dried wood on an average = .48; soft, easily worked and splits well; lasts well in dry localities, less so if exposed to weather. Timber of quickly grown trees is less durable than that of slow grown trees such as are produced in crowded

woods. It is used in Britain for a variety of purposes, principally as boards, planks and rafters. Used for the manufacture of paper. It yields inferior firewood. Strasburg turpentine is obtained from this tree.

*b. Distribution.*

It is found naturally in temperate Europe between the 36° and 52° of latitude. It is not indigenous in Britain; said to have been introduced nearly 300 years ago (1603 according to Brown). In its natural home it is a tree of the lower mountains, ascending to 2,500 feet in Central Germany, over 4,000 feet in the Alps, and 6,000 feet in the Pyrenees.

*c. Locality.*

*Climate.*—Silver Fir requires a fairly warm climate, and stands in this respect near the Beech. It is much exposed to late and early frosts, and is also tender as regards drought. It stands a great amount of shade, even more than Beech; in fact more than any other forest tree mentioned in this chapter. It requires a certain amount of moisture in the air, but not so much as Spruce. Northern and eastern aspects suit it best. It is fairly storm-firm.

*Soil.*—Silver Fir requires a deep, fresh and fertile soil, rather binding than loose. Loamy soils suit it best, though it will do well on sandy soils, if fresh. Dry or acid soils do not suit it.

*d. Shape and Development.*

The Silver Fir develops a straight and undivided stem, occasional forking excepted, with comparatively thin branches. The crown maintains a conical shape until the height-growth has been completed, when the top becomes flat; in free-standing trees it extends almost down to the ground, and even in crowded woods to nearly one-half the length of the stem. It has a fairly deep-going root-system.

Silver Fir is of very slow height-growth during the first 10 to 15 years of life, then the rate increases to such an extent that it reaches ultimately a greater height than any other British forest tree except Spruce, and the recently introduced Douglas Fir. Woods of an average height of 120 feet are frequently seen, and single trees occasionally attain a height of 150 feet.

In volume increment Silver Fir is probably only surpassed by the Douglas Fir. Silver Fir rarely reaches an age of more than 300 years.

*e. Reproductive Power.*

Silver Fir produces full crops of seed from the 70th year onwards. Such crops are but light, and they occur at intervals of two to three years in favourable localities. On the whole the reproductive power by seed is not great. Reproduction from the stool may be said to be *nil*.

*f. Character and Composition of Woods.*

Silver Fir is excellently suited for pure woods; it has a dense foliage, and maintains a cover overhead to an

advanced age, under which a thick growth of moss springs up, which, together with the shade, preserves a suitable degree of moisture in the soil.

It also forms a suitable stock with which other valuable timber trees, such as Spruce, Larch, Scotch Pine, Oak, &c., may be mixed. It is most frequently found mixed with Spruce, as they have the same shape and approximately the same height-growth. Silver Fir, being deeper rooted, protects the Spruce from being thrown by storms. Another most excellent mixture is Silver Fir and Beech, as they make similar demands on the locality. Oak in mixture with Silver Fir does well, provided the former has a decided start to prevent being outgrown. Silver Fir is a very useful species for under-planting Oak, Larch, and Scotch Pine, when these species commence to thin out, while they afford to the young Silver Fir the necessary shelter against late and early frosts.

#### *g. Sylvicultural Systems.*

Silver Fir is only adapted for high forest, more particularly for the shelter-wood systems with natural regeneration by seed. If grown on blanks it requires nurses to protect it against frost and drought while young. It may occasionally be seen as standards in coppice, but this is not advisable, owing to its dense foliage. As it does not reproduce from the stool, it cannot be grown as coppice; it makes, however, good hedges.

It is generally worked under a rotation of 80 to 120 years.

*h. Formation of Woods.*

It is, even more than Beech, specially adapted for natural regeneration under a shelter-wood. Direct sowing and planting should be done under a shelter-wood; if this is not available it must be artificially supplied, otherwise the young trees will suffer from late and early frost, and possibly also from drought.

The seed ripens in September to October, in England towards the end of the latter month. As the seed falls at once, the axis of the cone alone remaining on the tree, the cones should be gathered as soon as ripe. The seed rarely keeps its germinating power for more than six or seven months. If 50 per cent. germinate it is considered good seed. One pound of seed contains about 10,000 clean grains without wings.

Direct sowings may be made in spring or autumn, the latter season being on the whole preferable, as the seed is difficult to keep. If spring sowings are decided on, the seed must be kept in an airy loft and occasionally turned. Spring sowings sprout in from three to five weeks. About 40 pounds of seed per acre are required for broadcast sowings; it receives a cover of about two-thirds of an inch. Sowings in patches under the shelter of existing woods are more frequent than broadcast sowings.

In nurseries the seed may be sown in drills, or broadcast; the seedlings should remain for two years in the seed-bed, and two years and upwards in nursery lines. In England they are rarely put out under five years old. The young plants generally require protection against frost and drought.

The Silver Fir is best regenerated naturally under a

shelter-wood, the selection and group system being perhaps even better suited to it than the compartment system. The process of regeneration is a slow one. In most mature Silver Fir woods groups of advance growth are found, where operations may be commenced. By removing the shelter trees standing over such advance growth, and gradually the adjoining trees, regeneration extends all round, and the groups expand until they ultimately merge into each other. In this way the regeneration period of a wood may extend over 30, 40, and even 50 years. The old trees, being gradually placed into an open position, increase rapidly in diameter, volume and value. At the same time they should be removed when the young crop demands it.

#### *i. Tending.*

*Fertility of Soil.*—Silver Fir, if treated properly, is an excellent preserver of the fertility of the soil.

*External Dangers.*—The young trees require shelter against frost and drought for 10 and sometimes even 20 years. This is given either by the mother trees or by an artificial shelter-wood of Larch, Scotch Pine or Birch. This period passed, the tree is comparatively free from danger. Storm and snow may do damage, but not nearly so much as in the case of Spruce. Cattle and deer nibble it, and the latter sometimes peel it, but it heals such damage easier than the other Conifers. Squirrels bite off the leading shoots.

*Insects* are, on the whole, not very destructive. Two species of Tortrix (*T. murinana* and *rufimitrana*) destroy the needles and shoots, especially in Central Europe.



A weevil, *Pissodes piceæ*, peculiar to this species, is destructive chiefly to sickly trees. The wood-wasps (*Sirex*) and some *Tomicidæ* bore into the wood, especially when newly felled.

Mistletoe is frequently found on Silver Fir, perforating the wood and reducing its value.

Of *Fungi*, *Æcidium elatinum*, Lk., must be mentioned, which causes witches' broom and cancer on the Silver Fir; this evil occurs sometimes on a large scale. To meet it the diseased stems should be cut out as soon as possible. Of other fungi, *Phytophthora omnivora*, *Pestalozzia Hartigii*, *Agaricus melleus* and *Trametes radiciperda* may be mentioned, but they do less damage than in the case of Spruce.

The Silver Fir stands *pruning* well.

Young Silver Fir woods should be carefully watched, especially if mixed with other species, lest the slow-growing Silver Fir may be outgrown and injured.

*Thinnings* need rarely commence before the 25th or 30th year; they should be light until the woods enter the last third of their life, when they should be heavy, so as to cause the remaining trees to increase rapidly in diameter. Throughout the thinnings all trees infected with cancer should be removed, unless by so doing the wood might become too open; in some cases it may be possible to remove the witches' broom before the stem has become infected.

15. COMMON OR NORWAY SPRUCE = *Picea excelsa*  
(Link.)

*a. Utility.*

The timber of the Spruce is light, with a specific gravity of .47 on an average; soft and splits well; somewhat more durable than that of Silver Fir. It is known in Britain as white Baltic pine, the principal tree of the European timber trade, and used for a great variety of purposes, chiefly in the shape of boards, planks, and scantlings. The timber grown in Britain is frequently of inferior quality, owing to its rapid growth. It yields a fair fuel, and is used for the manufacture of paper. The bark is used for tanning. The tree yields turpentine.

*b. Distribution.*

The Spruce is found naturally in Europe from the 68th degree of latitude down to the Alps, or about 44°. It is a tree of the mountains, being found up to an elevation of 6000 feet in the Alps. On proceeding north it gradually descends, until it is found along the sea-shores of the Baltic as a tree even of the low lands. Nevertheless, in Norway it rises still to a height of nearly 3000 feet. The tree has been introduced far beyond its natural limit. It is said to have been first planted in Britain in 1548 (Brown).

*c. Locality.*

*Climate.*—Spruce requires relatively little heat; it stands a considerable amount of winter frost, but it is somewhat tender as regards late frosts, though not

nearly so much as Silver Fir. It is very tender in respect of drought. It is a shade-bearing tree, standing, amongst conifers, next to Silver Fir, though the latter bears considerably more shade. The Beech, also, is more shade-bearing than the Spruce. These three species, together with Hornbeam, are the principal shade-bearing timber species of temperate Europe.\* Spruce demands moist air to do well; hence, in the centre of its natural home, it prefers north-easterly aspects. It is the least storm-firm species of the trees mentioned in this book.

*Soil.*—Spruce is satisfied with a shallow soil of middling porosity, which must be at least fresh, and may be moist, or even wet, provided it is not actually swampy and acid. It does not stand inundation, and absolutely avoids dry soils. It is moderately exacting as regards the chemical composition of the soil, and reaches its greatest perfection on loams and shales.

#### *d. Shape and Development.*

Spruce develops a straight, undivided stem, with thin branches, which become somewhat drooping with advancing age. The crown retains a conical shape throughout life; in crowded woods it is restricted to the upper third of the stem. Spruce has a shallow root-system.

Spruce grows at first rather slowly, but faster than Silver Fir; when 10 to 15 years old its height-growth becomes rapid, and it ultimately reaches the greatest

\* See page 118 of Volume I.

height of the indigenous trees of temperate Europe, up to 150 feet, with a diameter up to 5 feet.

In volume-growth it is only surpassed by Silver and Douglas Firs.

Its maximum age may be placed at 300 years.

*e. Reproductive Power.*

Spruce begins bearing full crops of seed after the age of 50 years; they are heavy, and, under favourable conditions, occur about every 3 to 5 years. On the whole, reproduction by seed is favourable, more so than that of the other shade-bearing species. There is no reproduction from the stool.

*f. Character and Composition of Woods.*

Spruce occurs in extensive pure woods, for which it is well adapted; it has a dense foliage, and preserves a complete cover for a considerable time, in fact until near maturity. Under its shelter a heavy growth of moss springs up, which keeps the soil moist; at the same time the shallow root-system of the Spruce is liable to drain the upper layers of the soil.

It is a suitable tree for mixture with many species, such as Silver Fir, Beech, Larch, and Scotch Pine, but less so with Oak, which is liable to become stag-headed in mixture with Spruce. It is not so well suited for underplanting as Beech and Silver Fir. If mixed with Silver Fir and Beech it is apt to outgrow and injure them.

*g. Sylvicultural Systems.*

Spruce is treated as high forest under the clear-cutting and shelter-wood systems; both succeed well, but the former somewhat better. In the case of the shelter-wood systems the mother trees<sup>1</sup> are liable to be thrown by storms. For the same reason Spruce is not suited for standards.

Spruce is treated under a rotation of 60 to 120 years. It makes excellent hedges, and is also much grown for wind-breaks along the edges of woods.

*h. Formation of Woods.*

Spruce woods can be formed naturally or artificially, the latter method being more practised. Under ordinary circumstances it does not require shelter when planted.

The seed ripens in October, and falls towards spring, the cones remaining on the tree for some time afterwards. It preserves its germinating power for 3 to 5 years. Of good seed 75 per cent. should germinate. One pound of seed contains about 65,000 clean grains. Direct sowings should be made in spring; the seeds should receive a covering of  $\frac{1}{2}$ -inch of soil; they germinate after 3 to 5 weeks. About 10 pounds of clean seed per acre are required for broadcast sowings.

Sowings in nurseries may be done broadcast or in drills. British nurserymen prefer the former, sowing about  $\cdot 6$  of a pound of seed per 100 square feet of seed-bed. The seedlings can be pricked out when one year old, but they are generally left two years in the seed-bed; after they have stood for two years in nursery

lines they are put out into the forest; frequently they are left 3 years.

On the Continent, Spruce is planted in a variety of ways; as seedlings, with or without balls of earth, or as transplants; either one plant may be placed into each planting spot, or sometimes several plants are put together, so-called *bunch-planting*; the latter method is now little followed.

Natural regeneration is effected both under shelter-woods, and on clear cuttings the seed coming from adjoining woods. If under a shelter-wood, the seeding cutting is made fairly strong, and the final stage is short as compared with Beech and Silver Fir, because the young trees do not require so much shelter and are less shade-bearing, while the mother trees are liable to be thrown by storms after the cover has been interrupted.

#### *i. Tending.*

*Fertility of Soil.*—Spruce is quite capable of preserving the fertility of the soil as long as the cover is not interrupted.

*External Dangers.*—Spruce is much exposed to dangers. From late frosts it suffers only to a moderate extent, but is very tender as regards dry winds and drought generally. Persistent cold winds also are liable to injure young Spruce. Hence it is essential to keep the edges of Spruce woods as dense as possible. The tree is easily thrown by storms, and it suffers very extensively from snow and rime; either the crown is broken, or whole trees, and groups of trees, are thrown down.

The Spruce has many insect foes, and recovers less readily from injury than the Scotch Pine. The seedlings and young plants suffer like those of the Scotch Pine, *Hyllobius abietis* being a great danger (page 301). Many *Tortrices* live on the twigs and needles; the chief devourer, however, is the nun, *Liparis monacha*, which has caused widespread destruction. The Spruce-gall Aphis, *Chermes abietis*,\* cripples the shoots. The bark-beetles, *Tomicus typographus* and its allies, are the most destructive insects. They especially follow caterpillar-attacks, and are perhaps more dreaded than any other forest-insects of Europe.

Spruce is also much infested by *fungi*. Young seedlings are attacked by *Phytophthora omnivora*, which kills large patches of them in nurseries. Young plants up to a few years old become yellow and succumb, owing to *Pestalozzia Hartigii*. *Trametes radiciperda* and *Agaricus melleus* attack the roots. Red-rot is produced in the root and the stem by *Polyporus vaporarius*; white-rot by *Polyporus fulvus* and *borealis*, *Trametes radiciperda* and *pini*; green-rot by *Peziza æruginosa*. There are many other species of minor importance.

Young Spruce woods require watching, lest Birch, Aspen, and Willow should settle in them and injure the Spruce.

*Pruning*.—Spruce does not stand the pruning of green branches, the operation being generally followed by a falling off in height-growth. Opinions differ regarding the expediency of pruning off dry branches;

\* There is some reason to believe that this is identical with *Chermes laricis*, the insect breeding alternately on Spruce and Larch.

in many cases it improves the quality of the timber considerably.

*Thinnings* generally commence at the age of 20 to 25 years; they should be light, and frequently repeated up to the age of 50 years. This is necessary, as snow breakage may occur during this period, followed by a considerable interruption of the cover. After the age of 50 years the thinnings may be heavier.

## 16. SCOTCH PINE = *Pinus sylvestris* (L.).

### *a. Utility.*

The timber is light, average specific gravity, air-dried, = .52, soft, but somewhat harder than that of Spruce or Silver Fir; durable if impregnated with turpentine and not grown too quickly, more durable than that of Spruce and Silver Fir. The value of the timber depends much on the locality where it has been grown, the treatment of the woods, and the age of the trees; the timber of slow-grown old trees, if sound, is far superior to that of fast-grown or young trees. It is used for a great variety of purposes in the shape of boards, planks, and scantling, for railway sleepers and mining props. It is imported into Britain as red Baltic pine. A fair fuel. It yields turpentine. From the needles an aromatic oil is prepared.

### *b. Distribution.*

It is found in Europe between latitude 37° and 70°, also in Asia. Its centre of distribution are the countries around the Baltic and German Ocean. Indigenous in Great Britain and Ireland. It is eminently



a tree of the low lands; prefers southern aspects in mountains. It ascends to 2,200 feet in Britain, about the same in Northern Germany, and up to 5,000 and sometimes even 6,000 feet in the Alps.

*c. Locality.*

*Climate.*—Scotch Pine is hardy against frost and drought, but flourishes best in a fairly warm climate. It is light-demanding, standing in this respect between Larch and Oak. The degree to which it will bear shade is very limited, but it depends much on the climate in which it is grown. It prefers dry to moist air, but possesses an enormous power of accommodation in this as well as other respects. Scotch Pine is a storm-firm tree.

*Soil.*—Scotch Pine requires a deep soil, which should be porous. Although it reaches its greatest perfection on fresh soil, it will grow under any conditions of moisture, from very dry soil to swampy ground. Sandy soils with a moderate admixture of loam suit it best, but it accommodates itself to any description of soil, from shifting sand to clay. It is not an exacting species as regards mineral substances in the soil.

*d. Shape and Development.*

The natural tendency of the tree is to divide its stem only in the upper part into a limited number of strong branches. In crowded woods the crown is restricted to the uppermost part of the tree. The stem is not so straight as that of Spruce or Silver Fir. Scotch Pine develops a tap-root, and a generally deep-going root-system.

Scotch Pine grows quickly in youth and also afterwards, attaining, under favourable circumstances, an ultimate maximum height of about 120 feet. The average height of crowded woods grown on fertile soil and under a favourable climate may run up to 100 feet.

As regards volume-increment it stands below Silver Fir, Spruce, and Larch, but above the broad-leaved species. The upper limit of its life may be placed at 200 years.

*e. Reproductive Power.*

Full seed-years commence when the tree has passed an age of 30 years; they are heavy, and occur about every third year. On the whole, reproduction by seed is favourable.

*f. Character and Composition of Woods.*

Scotch Pine occurs in extensive pure woods, owing to its general usefulness and its accommodating power, less on account of its power to maintain the fertility of the soil. During youth, and up to the age of 30 to 50 years, according to circumstances, Scotch Pine is soil-improving, and maintains the moisture in the soil, owing to the cover overhead and the growth of moss on the ground. When that age has been reached, the woods begin to thin out, and they are no longer capable of doing justice to the soil; the moss is replaced by grass, the humus disappears, and a suitable degree of moisture in the soil is endangered.

It is well suited for intermixture with Beech and

Silver Fir woods, also with Weymouth Pine and Spruce. It holds its own against these. In the moist climate of Britain it is also grown in mixture with Larch and Oak. It may be usefully underplanted with Silver Fir, Beech, Spruce and Douglas Fir, to which it affords a suitable shelter.

#### *g. Sylvicultural Systems.*

Scotch Pine is generally treated as high forest with clear cutting, exceptionally only under the shelter-wood systems. It is well suited for standards in high forest, as well as in coppice. It is extensively grown as a shelter-wood for frost-tender species.

#### *h. Formation of Woods.*

Scotch Pine may be sown or planted on clear cuttings, or regenerated naturally, either under an open shelter-wood or on cleared areas from adjoining woods. Planting is the usual method. No shelter is required by the young plants.

The seed ripens in October of the second year, but does not fall until the following spring, so that in autumn three kinds of cones may be seen on the trees, namely, six months old unripe cones, 18 months old just ripe, and empty cones of the previous crop. The germinating power is maintained for 2 or 3 years. Of good seed at least 70 per cent. should germinate. One pound of seed contains about 70,000 clean grains.

Direct sowings should be made in spring, the seeds being covered by about half-an-inch of earth. About six pounds of seed are required per acre for broadcast sowing; it germinates after 3 or 4 weeks.

Sowings in nurseries are mostly made broadcast, sometimes in drills. British nurserymen sow broadcast about 6 pound of seed per 100 square feet of seed-bed. The seedlings may be pricked out when one or two years old. In Britain seedling plants are now rarely put out into the forest; transplants are used which may have stood one or two years in the nursery lines; older plants are rarely used. On the continent sometimes seedlings are put out direct into the forest. In Britain notching is the usual method of planting, but peg and pit plantings are also done.

In the case of natural regeneration under an open shelter-wood, only a limited number of trees per acre, not more than 30, should be left, and these should be removed after two or three years; if the area has not been naturally stocked, sowing or planting should be done. If the seed is to come from adjoining woods, the cleared area should not be broader than about the height of the trees, and must be so situated that the seed is blown on to it. If regeneration does not occur within two or three years, sowing or planting must be done.

#### *i. Tending.*

*Fertility of Soil.*—Except on favourable localities, the fertility of the soil is liable to suffer, after the Scotch Pine has passed the age of 50 years; hence it should be underplanted between the 30th and 50th year with Beech, Silver Fir, Douglas Fir, or Spruce.

*External Dangers.*—Scotch Pine requires no protection against frost or drought; frost-lifting may occur in

early youth. It suffers, however, very much from snow and rime, and Scotch Pine woods are much exposed to fires; to protect them against the latter, regular fire traces must be cleared and a strict watch kept, during dry weather, over the use of fire in the woods and in their vicinity. The tree is not much subject to be thrown by wind, except on a shallow soil over an impermeable stratum; its branches and top are, however, liable to be broken.

Scotch Pine is nibbled by cattle and game, but rarely peeled. Rabbits do much damage by peeling the bark of young trees near the ground, and squirrels by peeling them later on in the upper part. The number of these animals should be reduced by shooting, or trapping in the case of rabbits.

Scotch Pine is liable to a greater variety of *insect injuries* than any other tree, especially when grown on poor soil. Seedlings are destroyed by wire-worms, *Tipula* larvæ, and millipedes, also by chafer-grubs. Young plants (2 to 5 years) are injured by root-feeding bark-beetles (*Hylastes*), and they are gnawed by numerous weevils, especially *Hylobius abietis*, which kills a large number. The needles are destroyed by the larvæ of *Liparis monacha*, *Fidonia*, *Trachea*, and other moths; *Lophyrus pini* and other sawflies; and on the Continent by *Gastropacha pini*, which frequently kills the trees. *Retinia* larvæ cripple the terminal shoots, which are also thinned out by *Hylurgus piniperda*. Many weevils, *Pissodes*, *Magdalinus*, *Tomicus bidentatus*, &c., live in the bark and twigs. The *Siricidæ* and Longicorn beetles live in and destroy the wood.

*Fungi* prey upon Scotch Pine to a very considerable extent. *Phytophthora omnivora* kills very young seedlings. Young plants and trees up to an age of about 30 years lose their needles after becoming yellow or brown; the cause of this has not yet been satisfactorily explained, though in many cases a fungus (*Hysterium Pinastris*) is present, and may occasion the disease, which is termed *Schütte* in German. Both *Agaricus melleus* and *Trametes radiciperda* do much damage. *Peridermium Pini* causes cancer by drying up the bark and cambium all round the tree, and kills the part above it; such trees in England are called "foxy." White-rot is produced by *Trametes Pini*; red-rot by *Polyporus vaporarius* and *mollis*; a bluish-black rot by *Cerastoma piliferum*.

*Pruning* of green branches cannot be recommended; dry branches may be removed. Occlusion is slow.

*Thinnings* may be commenced between the ages of 10 to 20 years, according to circumstances; they should be light and frequently repeated until middle age. If it is then decided to underplant the Scotch Pine, the thinnings must become heavier; if not, they should continue to be moderate, so as to preserve as complete a cover as practicable. At the same time, trees are constantly dying off from various causes, such as insects and fungi, or they are broken by snow and rime. Such trees must be removed as speedily as possible; hence dry-wood cuttings are more frequent in Scotch Pine woods than in any other.

17. BLACK OR AUSTRIAN PINE = *Pinus Laricio* (Poir.),  
var. *austriaca*.

a. *Utility.*

The Austrian Pine yields a light soft wood, which is very rich in turpentine, and very durable. Specific gravity, air-dried, = .57. It is a good building timber, and the tree yields more turpentine than any other European conifer. The needles are used in the manufacture of an article which comes into commerce as "forest wool."

b. *Distribution.*

Lower Austria, Hungary, Croatia, Dalmatia and the south-eastern Alps, where it ascends to about 4500 feet. Introduced into Britain during the present century.

c. *Locality.*

*Climate.*—The tree is frost-hardy and not sensitive to drought. It demands light, but stands more shade than the Scotch Pine, standing between that tree and the Weymouth Pine. It prefers dry air, and is storm-firm. Suffers much from snow and rime, even more than Scotch Pine.

*Soil.*—It likes a moderately deep, porous and fairly moist soil, which need not be fertile. In its natural home it is chiefly found on calcareous soils, especially over dolomite formations, but it thrives almost equally well on any other formation. Its demands on fertility and moisture are even less than those of the Scotch Pine, so that it grows on shallow dry soils, even on rocks. It is

considered one of the least exacting of the European timber trees.

*d. Shape and Development.*

The tree develops a straight stem; the crown is similar to that of the Scotch Pine, but fuller, stronger and denser. Its height-growth is somewhat slower than that of the Scotch Pine, and it does not, as a rule, exceed a height of 75 feet, at any rate when grown beyond its natural home. The root-system is strong, and similar to that of Scotch Pine. The volume growth is smaller than that of Scotch Pine. It is said to attain a great age in its natural home.

*e. Reproductive Power.*

The tree commences producing full crops of seed after it has passed an age of 30 years, and they occur every 2 to 3 years.

*f. Character and Composition of Woods.*

The Austrian Pine appears in extensive pure woods in its natural home, and it is better suited to be so grown than the Scotch Pine, because it has a denser crown, which shades the soil better, preserves a complete leaf-canopy to a more advanced age, and acts beneficially on the fertility of the locality. It can be mixed with the same species as Scotch Pine, but demands more protection against being outgrown and suppressed. It does not require underplanting to the same extent as Scotch Pine.



*g. Sylvicultural Systems.*

High forest with clear cutting, but also the shelter-wood systems. It can be used as nurses over and between tender species; makes a good wind-break along the edges of woods.

*h. Formation of Woods.*

Planting is the rule, but natural regeneration under a shelter-wood, or by adjoining woods, is also practised.

The seed ripens at the end of October in the second year, and falls towards and during the following spring. It retains its germinating power for 2 to 3 years. Of good seed 75 per cent. should be capable of germinating.\* About 24,000 seeds go to the pound.†

The treatment of the seed and seedlings in the nursery is the same as for the Scotch Pine.

*i. Tending.*

This is similar to that of the Scotch Pine. The Austrian Pine is exposed to the same dangers as the Scotch Pine, but in a less degree; from snow and rime it suffers, however, somewhat more. It possesses the same insect enemies as Scotch Pine (page 301), but is less frequently injured. A snail (*Bulimus delictus*) is an especial foe to young plants, which it kills by eating the last year's needles in spring.

Fungi are the same as those found on the Scotch Pine, but they do less damage.

\* According to Gayer.

† According to Hess.

18. WEYMOUTH PINE = *Pinus Strobus* (L.)  
(The White Pine of North America.)

*a. Utility.*

The Weymouth Pine yields a soft light wood, of which enormous quantities are used in North America, and exported to Europe and other countries as American "white pine." The timber produced in Europe has a specific gravity of .43,\* and is moderately durable. It is used in building, as boards and planks by joiners, carpenters, carriage builders, for matches, toys, paper manufacture, and a great variety of other purposes. It is of somewhat less value than the timber of the Scotch Pine.

*b. Distribution.*

The Weymouth Pine is a native of the eastern parts of North America, where it is found between latitudes 35° and 50°. It was introduced into England in 1705, and has since been planted in various European countries.† In the Alps it is now found up to 4000 feet elevation.

*c. Locality.*

The following notes are based on experience gained in Europe :—

*Climate.*—The Weymouth Pine makes moderate demands on temperature; it is hardy as regards winter, late and early frosts, and also drought. As regards light-requirement it stands half-way between light-

\* According to Hess.

† According to Brandis it is not improbable that it was grown in Paris in the 16th century.

demanders and shade-bearers. It is storm-firm, and resists snow and rime well.

*Soil.*—It has been found to do best on deep porous, fresh, loamy sands, but accommodates itself to dry poor soils, as well as to moderately swampy ground; it seems however to avoid calcareous soils. It resembles in these respects the Scotch Pine, but demands perhaps a little more moisture in the soil, and is generally a little more exacting.

*d. Shape and Development.*

Weymouth Pine develops a straight and undivided stem, with a fairly dense crown, which in crowded woods is restricted to the upper part of the stem.

During the first three or four years it grows more slowly in height than the Scotch Pine, which it generally catches up by the eighth or tenth year, when it keeps ahead of it, reaching a maximum height of 120 feet or even more. In America, trees of 150 feet in height are frequently seen. Grown in crowded woods it produces a cylindrical stem, but when grown in the open it tapers considerably. Its volume-growth is greater than that of Scotch Pine. The root-system is deep-going, similar to that of Scotch Pine. It is said to reach an age of 400 years in its natural home.

*e. Reproductive Power.*

The tree commences bearing full crops of seed when about 30 years old; these occur every 2 or 3 years, but a certain quantity of seed is produced almost every year.

*f. Character and Composition of Woods.*

In its natural home the Weymouth Pine appears in pure woods over extensive areas, but even more frequently is found mixed with other species, especially broad-leaved trees. It is well suited for pure woods, as it has a fairly dense crown, maintains a sufficient leaf-canopy until towards maturity, and preserves a favourable layer of humus and moss on the ground. In Europe it is grown chiefly with Scotch Pine, Spruce, Larch and Silver Fir, when it generally holds its own. It is also well suited for mixture with Beech.

*g. Sylvicultural Systems.*

High forest, with clear cutting; fairly suited for under-planting Oak on sandy soils, and also Larch and Scotch Pine; well suited for filling up blanks in young woods. Can be grown as standards in coppice, also as nurses over and between tender species.

*h. Formation of Woods.*

Planting is the rule, the seed being frequently too expensive for direct sowings. The natural regeneration of the tree has been found to be very slow in Europe.

The seed ripens in September or October of the second year, and falls almost immediately. It retains its germinating power for 2 to 3 years. Of good seed 65 per cent. should be fit to germinate. One pound of seed contains about 30,000 grains.\* The raising of plants in nurseries is similar to that described for Scotch Pine.

\* Of the last supply of seed used in the Coopers Hill Forest Nursery, 26,000 clean grains weighed one pound.

As Weymouth Pine plants are more costly than those of Scotch Pine, they are generally treated with more care in transplanting, being as a rule placed in pits.

*i. Tending.*

Weymouth Pine preserves the fertility of the soil. It requires protection against cattle and deer. Damage by insects is, according to present experience, not of much importance. Young plants are injured by a Coccid, *Chermes strobi*, and older ones by the gnawing and breeding of a weevil, *Pissodes pini*. A bark beetle, *Tomicus bidentatus*, is occasionally injurious.

The Weymouth Pine suffers from many of the fungi which attack Scotch Pine, but in a less degree. *Agaricus melleus* and *Trametes radiciperda*, however, do more damage, as they frequently kill young trees of this species.

The woods should be kept crowded so as to kill off the lower branches, hence thinnings must be light until the height-growth falls off. The dry branches remain for a long time on the stem, and it is desirable to remove them. Cutting off green branches cannot be recommended, because it causes the stems to grow unevenly.

19. LARCH = *Larix europæa* (D.C.).

*a. Utility.*

The timber is moderately heavy, average specific gravity, air-dried, = .62, soft, split fairly well, very durable, lasting longer than any other coniferous timber grown in Britain; it yields good firewood.

Larch is the best coniferous timber grown in Britain, for construction above and below ground; it is also used for ship building. In Britain it is used for a great variety of purposes; it is much prized for railway sleepers, mining purposes, and makes an excellent fence-wood. Its price per cubic foot is generally about double that of Scotch Pine timber. The bark is used for tanning and dyeing. It yields Venetian turpentine.

*b. Distribution.*

The homes of the Larch are the Alps, the Carpathian and Moravian mountains, and Siberia. It has been cultivated in many countries, so that it is now found all over Europe between about the 42nd and 58th degrees of latitude. Larch is a true mountain tree; it is generally found in the Alps between 3,000 and 6,000 feet elevation, but goes up to 7,000, that is to say to the upper limit of tree growth. It is said to have been introduced into Britain in 1629 (Brown). Its cultivation in Scotland was commenced about the year 1725, the Duke of Athol having begun planting it over extensive areas about that time. It is found in the Highlands up to about 2,000 feet elevation, though its cultivation does not generally pay if planted above 1,500 feet.

*c. Locality.*

*Climate.*—Larch can do with a lower mean annual temperature than any other timber tree mentioned in this chapter. It suffers from drought, is hardy against frost in its natural home, but liable to suffer somewhat

from late frosts in low lands owing to its very early sprouting in spring. It is highly light-demanding, in fact more so than any other British timber tree. The climatic conditions required by Larch have been much discussed. The majority of foresters believe that it prefers a dry atmosphere, a free and airy position, and northern and eastern aspects. It is more storm-firm than the other conifers.

*Soil.*—Larch requires a deep, fairly porous, and moderately fresh soil; it avoids wet as well as dry soil. It is fairly exacting as regards the general fertility of the soil; loamy soil containing a good proportion of potash and lime suits it best; in its natural home it is much found on stony soils, provided they are fresh.

The natural home of the Larch enjoys only a short growing season, with a late and very short spring and comparatively hot clear summer. These are conditions which seem to suit it. Britain, on the other hand, shows a much longer growing season, especially a long spring, a moister atmosphere and a more cloudy summer—in other words conditions which are altogether different from those prevailing in the natural home of the Larch. It is not astonishing, therefore, that this valuable tree, although it grows most vigorously, suffers excessively from disease in Britain, as will be indicated under *i*.

#### *d. Shape and Development.*

Larch has an undivided stem, with a conical thin crown; the lower part of the stem is frequently curved where the tree is exposed to wind. In crowded woods

the branches are restricted to the uppermost part of the stem. It develops a tap-root, and generally a fairly deep-going root-system.

It is a quick height-grower from the beginning and until it has reached nearly its full height, which may be placed at about 120 feet under favourable circumstances. As regards volume-increment it stands between Silver Fir and the Pines.

Ordinarily it would not exceed an age of 300 years, though it is said in the Alps sometimes to reach double that age.

*e. Reproductive Power.*

Full seed-years commence at the age of about 30 years; they are light, and may be expected every 3 to 5 years. A certain quantity of seed is produced almost every year. On the whole, the reproductive power by seed is not very great.

Larch possesses a certain power of reproduction by shoots, but this is of no practical value in Sylviculture.

*f. Character and Composition of Woods.*

Larch preserves a sufficient cover overhead only for a limited period, generally not exceeding 30 years, when it begins to thin out, admitting sun and air-currents, which cause the needles to decompose quickly, and the previous growth of moss to make way for grass. Hence it is not suited for pure woods, except on fertile soils or under specially favourable climatic conditions. It is far preferable to mix Larch into other species with



a dense foliage, such as Beech, Silver Fir and Spruce,\* against which it holds its own. In Britain it is also mixed with Oak and Scotch Pine, but neither of these mixtures is a good one in itself; if it is nevertheless employed, the reason is to be found in the fact that these two species are more valuable as timber trees than the above-mentioned shade-bearing species, and because in the moist climate of Britain a departure from the rules which guide the forester in arranging mixtures is more permissible than in dry continental countries.

Whenever Larch is grown pure, it should be underplanted at the age of 20 to 30 years with one of the shade-bearing species mentioned above. In addition, the Douglas Fir may be suggested for this purpose, because it stands sufficient shade to grow under a thin Larch wood, it requires some protection during early youth, is a fast grower, and yields valuable timber. Even the Weymouth Pine may do for underplanting the Larch, provided the latter is strongly thinned beforehand.

#### *g. Sylvicultural Systems.*

Larch is treated as high forest, as standards in coppice, and it is frequently grown as a shelter wood over and between tender species. In high forest it may be treated under a rotation of 60 years and upwards, according to the size of timber required. It is useful to fill blanks in existing woods, owing to its rapid growth.

\* If further investigation should show that *Chermes laricis* and *abietis* are the same insect, a mixture of Spruce and Larch may become undesirable.

*h. Formation of Woods.*

Larch may be planted on clear cuttings; rarely sown; in favourable localities it can also be naturally regenerated.

The seed ripens in October or November, and begins to fall in the following spring; some of it remains in the cones until the spring of the second year, or even longer. The empty cones remain for several years on the trees. The germinating power is maintained from 2 to 4 years. If 35 per cent. germinate it is considered good seed. One pound of seed contains about 75,000 clean grains.

Direct sowings are made in spring, about 14 pounds of seed per acre being required for broadcast sowings; it receives a covering of about one-third of an inch, and it germinates after three or four weeks, if the seed is fresh; old seed germinates very irregularly. Direct sowings are rarely made.

In nurseries the seed may be sown broadcast or in drills. British nurserymen generally sow broadcast, about one pound of seed per 100 square feet of seed-bed. The seedlings are pricked out when one year old, or not at all. Plantings are done with two-year-old seedlings, or with transplants after they have stood one or two years in the nursery lines. Older plants are rarely used. In Britain the method of planting is generally notching; pit planting is also done. Planting must be done early in spring or in autumn, as the Larch sprouts very early.

Owing to its great light-requirement, the tree is not really suited for natural regeneration by seed; but if

this is attempted, the mother trees must be placed far apart, or the area clear cut in strips, allowing the seed to fall on them from adjoining woods. The method is only successful under favourable circumstances. At any rate, a second seed-year should not be awaited, but all areas not stocked by the first seed-year should be planted up.

*i. Tending.*

*Fertility of Soil.*—Pure woods only protect the soil sufficiently for about 25 to 30 years; hence they should be underplanted.

*External Dangers.*—In its natural home Larch is hardy; it suffers little from late frosts, and also not much from drought. The damage done by snow and rime is of moderate extent, and the tree is very storm-firm. In Britain it is not so storm-firm, especially if the soil should be saturated with water at the time of a gale; it also suffers somewhat more from late frosts, because it sprouts much earlier.

Roebuck and deer do a great deal of damage to Larch by injuring the bark, which is also peeled by rabbits. Squirrels peel the top shoots. Hence the tree should be protected against these animals by fencing and shooting.

Larch is much exposed to attacks by insects and fungi, and these dangers are much greater in countries where it has been artificially introduced. The Larch is especially attacked by minute moths, as *Coleophora laricella*, which hollows out the needles, and *Argyresthia lævigatella*, and several *Tortrices*. The "larch-bug," *Chermes laricis*, is very injurious. Nume-

rous bark-beetles live in the Larch in common with other conifers.

*Fungi.*—*Phytophthora omnivora* kills the young seedlings. *Peziza Willkommii* eats away the bark and cambium, causing cancer; this disease has now become so prevalent in many parts of Britain that the further production of the tree has become altogether problematic. *Agaricus melleus* kills the roots; *Trametes Pini* destroys the wood, leaving white spots; *Polyporus sulphureus* produces red-rot.

*Pruning.*—The Larch stands pruning well, but the operation affords an entrance for fungi, especially *Peziza Willkommii*; hence it should be done very sparingly. It is much better to grow the Larch so that the lower branches die off and fall naturally.

*Thinnings* must begin early. They should be light until the time has come for underplanting, when they must be heavy, leaving only healthy, vigorous, well-formed trees as the overwood which are to develop into large timber trees.

## 20. DOUGLAS FIR = *Pseudotsuga Douglasii* (Carr). (The Red Fir of North America).

The Douglas Fir is a native of the western part of North America, where it is found between latitudes 31° and 55° and longitudes 104° and 130°.\* It is considered the most valuable forest tree of North America, owing to its rapid growth, great dimensions and the excellence of its timber. The latter is said to be equal to that of

\*According to Professor C. S. Sargent.

Larch, while trees of over 300 feet in height, with a corresponding diameter, are said to exist. The tree was introduced into Britain in 1826 (Brown), and the experience so far gained singles it out as a most promising timber tree of this country; hence it was considered desirable to add it to the present list.

The silvicultural data at present available are not yet sufficient to give a complete set of notes on the treatment of the Douglas Fir in Britain. Numerous experimental plantations have been established in this country and in Germany, some of which are upwards of 30 years old (apart from single trees of greater age,) and the following remarks are based upon observations made in these, and on the information supplied lately by Dr. H. Mayr, in his interesting work on "The Forests of North America," 1890.\*

*a. Locality.*

The Douglas Fir reaches its greatest perfection on the slopes and in the moist valleys of the Cascade Mountains in Oregon and Washington, and in the coast districts of British Columbia, approximately between the 40th and 50th degrees of latitude. These territories have an annual rainfall of about 65 inches, with a moist atmosphere, the climate being comparatively mild. As regards soil, it appears that a deep, fertile, and at least fresh sandy loam suits the tree best; it seems to avoid stiff clay and also poor sandy soils. Under the most favourable conditions it here attains a height of about 300 feet.

\* Dr. Mayr, a Bavarian Forest Officer, and now Professor of Forestry and Forest Botany at Tokio, visited North America twice since 1885, and spent altogether seven months in its forests. He largely utilized Professor Sargent's investigations.

In the mountains of Montana, with a comparatively small rainfall of about 24 inches and a dry atmosphere, the Douglas Fir reaches, if grown on the most suitable soil, a height not exceeding 150 feet, which however is also the limit in the coast districts, if the tree is grown on moderately fertile soil. On poor soil, even in the latter districts, the maximum height is frequently found to be 100 feet or even less.

From these data it appears that the Douglas Fir, if it is to do well, requires a moist climate and a deep fertile, fresh or moist soil, especially light loam. It accommodates itself to a different climate and soil, but the height-growth falls off in due proportion.

In its natural home the Douglas Fir is said to be very hardy; it is in Montana exposed to great winter cold, and is found growing in the open. In the coast districts, with a long growing season, it is said to suffer from early frost. In Britain it has on the whole been found hardy; it has stood severe winter cold, but it seems liable to suffer from late or early frost when young, at any rate in Scotland, though not to an excessive extent.

To what extent the Douglas Fir may be considered storm-firm in Europe will depend on further experience; in Scotland many trees only 30 years old, grown in fairly crowded plantations, have been thrown. In exposed localities the leading shoots suffer to an excessive extent.

German foresters seem to consider the Douglas Fir to be a moderately light-demanding species. The author is more inclined to class it as a moderate shade-bearer, standing near Spruce, or still nearer the Himalayan Deodar.

*b. Shape and Development.*

The Douglas Fir develops a straight undivided stem, except that in some localities the first 6 feet from the ground are curved. Grown in the open the crown covers the whole stem and comes down almost to the ground; the stem of such trees is very tapering. If grown in crowded woods in its natural home, the lowest portion of the stem is exceptionally stout; the crown forms a sharp cone confined to the upper half of the stem, whilst the bole is described as of a remarkably cylindrical shape, at least as much as that of the European Silver Fir. A regular wood\* which the author has seen was 32 years old; in this all the trees were excessively tapering, giving a form figure of  $\cdot 39 \dagger$  for timber only (over 3" diameter at the thin end). Further experience may show that the trees with advancing age adopt a more cylindrical shape.

The growth of the Douglas Fir is exceedingly fast. At the same time it varies enormously according to climate and soil. According to Mayr, a wood 80 years old and grown under the most favourable conditions showed an average height of about 133 feet, or an average annual height-growth of nearly 20 inches. The Taymount plantation shows an average height-growth of about 22 inches.

In Montana, according to Mayr, the Douglas Fir shows

\* Taymount, on the estate of the Earl of Mansfield, Scotland; area = 8 acres; total age of trees = 32 years in 1888; number of trees per acre = 202; sectional area of trees at 4' 6" = 158.17 square feet; average height = 60 feet; volume = 3738 cubic feet of timber.

† Under *form figure* is here understood the proportion of the actual volume of the stem to a cylinder of equal height and equal cross section at 4' 6" from the ground.

a height-growth of about 10 inches on an annual average, or about one-half of that in the coast districts. Under any circumstances, as far as experience goes at present, the Douglas Fir, if planted in suitable localities, outgrows all European timber trees.

The tree also attains a great diameter; the average diameter of mature trees, 200 feet high, in the coast districts is given as about 6 feet, and in Montana as about  $2\frac{1}{2}$  feet.

It follows that the volume-increment is very great. Experience up to date shows that it exceeds the fastest growing of European trees to a considerable extent.

#### *c. Reproductive Power.*

Little is known about this, beyond that the trees grown in Britain produce seed freely, which has been used for rearing the younger plantations. In its natural home it frequently commences bearing seed when 10 years old.

#### *d. Character and Composition of Woods.*

Douglas Fir, grown in crowded woods, produces a complete dense cover overhead, and seems well adapted to be grown in pure woods; as far as can be judged at present, it is likely to maintain a complete leaf-canopy to a sufficiently advanced age to produce large-sized timber. It is, however, liable to suffer from storms in Britain, and at any rate the leading shoots are always injured, unless the tree is grown in a thoroughly sheltered position.

Under these circumstances the best results will probably be obtained by mixing it with other species. As it



stands a moderate amount of shade and grows very rapidly, it should be planted under Larch or Scotch Pine. The Larch may be planted pure, and when from 20 to 30 years old it should be strongly thinned, only healthy, vigorous trees being left, and underplanted with Douglas Fir. The latter will reach timber size at the same time with the Larch. The Douglas Fir will shelter the soil under the Larch, while the latter will afford the necessary protection to the leading shoots of the former which they require. In this way the Douglas Fir can be grown in localities where it could not be successfully reared pure. At the same time, under this treatment, very high returns may be expected.

The mixture of Scotch Pine and Douglas Fir may be arranged in the same way; but the underplanting may be postponed for another 10 years.

#### *e. Sylvicultural Systems.*

The Douglas Fir seems only suitable for simple high forest; it suffers too much from wind to be grown as a standard in coppice.

#### *f. Formation of Woods.*

So far the seed is very expensive, so that direct sowings are out of the question. No experience has as yet been gained regarding natural regeneration. For the present only planting is practised.

The seed\* and seedlings are treated in a similar manner to those of the Spruce. They must, however, receive

\* A pound of seed received from Mr. Conrad Appel, Darmstadt, contained 45,000 grains, which produced 8,000 healthy seedlings.

lateral shelter, or light top shelter as long as late frosts are feared. The seedlings may be pricked out when one year old, and planted out into the forest after they have stood one or two years in nursery lines; their development is very rapid, similar to that of Larch.

*g. Tending.*

Douglas Fir seems quite capable of preserving the fertility of the soil.

How much the tree is likely to suffer from external dangers in Britain will depend on further experience. So far it is certain that it suffers somewhat from late frosts while young, but is hardy afterwards. Dry winds are not likely to suit it. Strong winds injure the leading shoots, and have also thrown the tree in pure woods in Scotland.

Deer and roebuck are detrimental to the Douglas Fir, more especially on account of their peeling the bark.

It is not possible to say at present in how far Douglas Fir is likely to suffer from insects in Europe. It is attacked by a number of those which prey on the indigenous conifers, but further experience must show the extent to which it is likely to suffer from such attacks. Of fungi, *Botrytis Douglasii* kills the young shoots, and *Agaricus melleus* and *Trametes radiciperda* have been found on the tree.

The thinnings of Douglas Fir woods should be light for a considerable period, so as to cause the lower branches to die off, and the formation of cylindrical boles.

## APPENDIX TO CHAPTER IV.

NOTES ON BOTANICAL CHARACTERS SERVING TO DISTINGUISH  
THE PRINCIPAL BRITISH FOREST TREES.\*

(BY PROFESSOR H. MARSHALL WARD, M.A., F.R.S., F.L.S.)

## 1. SPRUCE.†

*Picea excelsa* (Link.). Abietinæ.

Tall, more or less conical tree, with arcuate branches. Twigs dark green to reddish brown. Bark shed in small scales, grey-brown with a tinge of red.

Buds rather long and pale. Each terminal bud flanked by a pair of lateral ones, and a few other lateral buds usually occur at intervals on the same shoot.

Leaves solitary, acicular, curved forwards, nearly quadrangular in section, spirally arranged all round the twigs; fine silvery lines of stomata on all sides. The leaves may persist for 6 to 7 years.

Male cones ovoid, rosy or purple when young, axillary or terminal on last year's branches. Female cones pendent, terminal, cylindrical, reddish; at length brown, with thin, leathery scales, toothed at edges. Ripen in one year, and fall as a whole.

\* It will be understood that these notes are for practical use in the forest, and are not intended to supersede more detailed examination of the botanical characteristics of the plants concerned.—H.M.W.

† The order in which the trees are taken in this Appendix, being governed by botanical considerations, necessarily differs from that adopted on sylvicultural grounds.—W.S.

Wood knotty, very white and satiny, with a tinge of yellow or pink. Sharp annual rings and few minute resin canals.

Seeds small, coffee-brown, with paler oval wing. Cotyledons generally 8 (vary from 5 to 10), curved upwards, finely toothed at edges. They persist till the third year.

## 2. SILVER FIR.

*Abies pectinata* (D.C.). Abietinæ.

Tall tree, with branches in tiers. Twigs green to brown. The cortex long persistent, and the stem smooth, silvery-grey. Bark not well-developed, marked by shallow longitudinal fissures and lozenge-shaped scales, often covered with lichens.

Buds much like those of the Spruce, but more silvery as they open.

Leaves differ from those of Spruce in being flattened, with two broad, silvery lines of stomata below, the apex blunt and emarginate, twisted so that they tend to lie right and left on the twigs. The leaves may persist for 8 to 11 years.

Male cones yellow, at the apex of last year's shoots. Female cones terminal, erect, dull green and then brown, with caducous scales, of two kinds, which fall at the end of the year and leave the erect naked axis.

Wood very like that of the Spruce, but almost devoid of resin-canals, and therefore less resinous.

Seed larger than that of Spruce, trigonal, and with a squarer wing. Cotyledons of seedling usually 5 or 6 (vary from 4 to 8), flat and spreading, and with the silver lines on upper surface.

## 3. DOUGLAS FIR.

*Pseudotsuga Douglasii* (Carr.). Abietinæ.

Very tall tree, but often irregular in this country. The periderm and scaly bark have a general resemblance to those of the Spruce.

Buds small, terminal; few lateral.

Leaves deep green, flattened, acicular, pointed, isolated, curved forwards, and arranged all round the twigs.

Female cones terminal, rather small, pendulous, falling as a whole. The barren scales project with three long teeth far beyond the sinuously rounded edges of the ovuliferous scales.

Wood rosy red, knotty, somewhat resembling that of the Larch, with sharply-marked annual rings and small resin-ducts.

Seed trigonal, with an obliquely oval wing. Cotyledons 5 to 7, triangular in section, and sharply pointed.

## 4. SCOTCH PINE.

*Pinus sylvestris* (L.). Abietinæ.

Large tree, with rounded crown in the open; pyramidal when young. Very variable.

Cortex of young branches green, passing into orange; bark red-brown, with large, thick, deeply-fissured scales.

Buds long and cylindrical in spring, and covered with the short twigs. Lateral buds flank the terminal one.

Leaves in pairs, rather short, glaucous, stiff; lasting about 3 years.

Male cones rosy to yellow. Female cones single, or few together; at first dark-green, then brown, small. They take 2 years to complete, and persist about a year after shedding seed.

Wood honey-coloured to reddish brown. Very resinous. Annual rings very distinct; medullary rays almost invisible.

Seeds winged, small; wings obliquely pointed. Cotyledons about 6, curving up; hypocotyl often red. Dead cotyledons hang on through the first winter.

#### 5. BLACK OR AUSTRIAN PINE.

*Pinus Laricio* (Poir.), var. *Austriaca*. Abietinæ.

Moderately tall tree, very variable in habit, and often resembling *P. sylvestris*, but darker and thicker foliage. The coarse scaly bark is formed higher up the trunk, and the scales are more violet or blackish, with silvery streaks. Young twigs dark green.

Buds long oval. Leaves in pairs; longer, thicker, and at length darker than *P. sylvestris*.

Female cones also larger, with broader, almost sessile base, and more spreading scales when old. Yellow-brown with bright apophyses.

Wood indistinguishable from resinous specimens of that of *P. sylvestris*.

Seeds like those of *P. sylvestris*, but rather larger. Cotyledons usually 7 or 8, and longer than in *P. sylvestris*. Hypocotyl glaucous or reddish.

## 6. WEYMOUTH PINE.

*Pinus Strobus* (L.). *Abietineæ*.

Tall conical tree, with thin, smooth, olive or slate-coloured cortex, often spotted with white resin drops. Buds sharp pointed.

Leaves 5, slender, tasselled, rather long and glaucous (but shorter, thinner, and darker than *P. excelsa*).

Male cones few and small. Female cones singly, or in pairs or threes, at ends of the twigs; when ripe, pendent, cylindrical, curved, with thin, persistent scales, obscure apophysis, and terminal umbo. (The cones of *P. excelsa* are similar but larger.)

Wood: yellowish white broad sap-wood, and orange to sienna heart. Not very resinous.

Seeds winged; the wing 5 times length of seed, brown (*P. excelsa* somewhat larger).

Cotyledons 8—11, trigonal, bright green (*P. excelsa* longer and more glaucous).

## 7. LARCH.

*Larix europæa* (D.C.). *Abietineæ*.

Large feathery tree. The young branches are yellowish or green-grey marked by green-olive or yellow raised lines. Bark scaly, with rosy lamellæ, and very rough when old.

Buds peculiarly globoid or stumpy and tuberculous in appearance.

Leaves soft, bright green, solitary and spiral on the

elongating shoots, but tufts of a dozen or more on the short ones. Deciduous.

Male cones shortly ovoid, yellow-green, and irregularly arranged along the branches. Female cones crimson and soft at first, rapidly attaining maturity, and then the thin scales become leather-brown. Barren scales pointed and short.

Wood: yellowish white narrow alburnum, red or nearly brown heart, with very distinct dark autumn zones. Resinous and irregularly knotted.

Seeds small and rather rounded, with nearly triangular wings. Cotyledons 6 (vary from 4 to 8), green, dying off the first autumn.

## 8. ALDER.

*Alnus glutinosa* (Gaertn.). Betulaceæ.

Moderate-sized, dark-hued tree. Young branches greenish brown to olive, with glands and large lenticels. Bark dark brown, with large plates.

Buds rather large, fat, and stalked; ovoid obtuse, smooth, sticky, and showing 2 or 3 scales of a dark greenish brown colour.

Leaves more or less viscid, alternate, petiolate, obovate or almost orbicular, and irregularly truncate at the apex; somewhat irregularly toothed; dark bright green above.

Flowers in monœcious catkins, showing in winter; the male catkins long, cylindrical and pendulous, the female cone-like in general appearance, and dark green. Female flowers in pairs.



Fruits somewhat like those of Birch, but more nut-like, and not winged.

Wood best distinguished from that of the Birch by the narrower and deeper medullary rays on tangential sections.

Seeds fused with pericarp; only one ripens. Seedling like that of Birch, but larger, and first leaves less hairy.

## 9. BIRCH.

*Betula alba* (L.). Betulaceæ.

Erect slender tree, with more or less pendent twigs, with smooth purplish cortex covered with lenticels and glands.

Periderm flaking off in silvery paper-like layers. Base of old trunks with very rugged, deeply fissured, hard bark.

Buds small, ovoid, pointed, smooth, purplish-brown.

Leaves petiolate, pendent, rhomboid, triangular to ovate acuminate, irregularly bi-serrate, dark green above, often glandular when young.

Flowers in monœcious pendent catkins, the male being the longer and larger; both visible in winter, and opening before the leaves in spring. Female flowers in threes.

Fruits small, flat, laterally winged by relatively broad membranous expansions, in the axils of trilobed compound scales.

Wood pinkish white, with very fine vessels and narrow, but visible, medullary rays; pith flecks common.

Seeds minute, singly in the small fruits. Seedling very small, cotyledons oval, as big as the head of a common pin. First leaves not much larger, lobed, very hairy.

## 10. OAK.

*Quercus Robur* (L.). Cupuliferæ.

Large spreading tree with zigzag, gnarled branches. Bark brown, and rough with irregular longitudinal fissures. Young branches silvery grey and smooth; many are cast off.

Buds short, rather large, fat, ovoid, scaly and pale brown; tend to be clustered at ends of twigs.

Leaves alternate, obovate to oblong, sinuous or pinnately lobed, sub-sessile, and somewhat auricled at the base (the variety *sessiliflora* has distinct petioles  $\frac{1}{2}$  to 1 inch long), pale olive and apple-green when young, dark and smooth when mature. Young trees tend to retain the dead leaves in winter.

Male flowers yellowish green, in small tufts arranged along long slender, pendulous stalks, appearing in spring and very caducous. Female flowers pinkish, in threes, in small clusters sessile near the end of erect, stiff peduncles (the variety *sessiliflora* has the female clusters sessile in the axils of the leaves).

Fruit, the well-known acorn, single in a scaly cup.

Wood yellowish when young, and in the narrow alburnum; the heart-wood grey-brown to dark brown, pith and earlier annual rings pentagonal. Some of the medullary rays very broad. The spring vessels very large.

Seed (enclosed in pericarp) exalbuminous, with large, fleshy, apposed cotyledons.

Seedling with long epicotyl, springing from between the buried cotyledons. Stem at first bearing scales (stipules) only, and then one stipulate typical leaf.

## 11. CHESTNUT.

*Castanea vesca* (Gaertn.). Cupuliferæ.

Large tree, with olive to reddish brown twigs marked with whitish lenticels. Young branches olive to silver-grey. Bark brown and Oak-like, but with longer furrows and often twisted.

Buds slightly displaced laterally, sharp-ovoid, only showing two or three scales.

Leaves alternate, petiolate, oblong-lanceolate acuminate, coarsely serrate.

Male flowers in small tufts arranged on stiff, erect stalks. Female flowers in threes, surrounded by an involucre; grouped at the tips of branches, or at the base of the male inflorescence.

Fruits (the edible chestnut) in twos or threes, surrounded by the prickly involucre, which splits to allow their escape.

Wood very like that of the Oak, but devoid of the broad medullary rays.

Seed (fused with the pericarp) exalbuminous. Cotyledons large, thick and fleshy, and remain buried in the soil. First leaf entire.

## 12. BEECH.

*Fagus sylvatica* (L.). Cupuliferæ.

Large somewhat spreading tree. No true bark: smooth, grey, thin, ash-grey cortex, usually with lichens and moss on it.

Young branches olive-green; long, smooth, pointed, pale brown, scaly buds. When the buds open in May, these long chaffy scales (stipules) litter the ground.

Alternate, thin, oval-acute, petiolate leaves; ciliate and pale green when young, smoother and darker when full grown. Shade dense.

Male flowers in silky, tassel-like tufts of about 5 to 15, on long pendulous stalks, in spring: caducous female flowers in pairs (occasionally three), enclosed in a four-lobed softly hairy involucre, erect, on short stalks.

Fruit of two three-angled, smooth, brown nuts, falling from the spreading brown and prickly involucre.

Wood reddish white, with numerous small scattered vessels; sinuous annual rings, and some of the medullary rays broad.

Seed (enclosed in pericarp) exalbuminous; cotyledons curiously folded.

Seedling with long hypocotyl, raising the two large sessile, half-orbicular, tough cotyledons into the air; these cotyledons are green above and almost white below. First leaves like the type.

## 13. HORNBEAM.

*Carpinus Betulus* (L.). Cupuliferæ.

Moderately large and somewhat spreading tree, with Beech-like habit, but distinguished by its buttressed trunk. Cortex (no true bark) smooth, thin, ash-grey, and very like that of Beech, and even more apt to be invaded by lichens and moss.

Young branches resembling those of the Beech, but easily distinguished by the buds, which are shorter and stouter, and somewhat appressed towards the twig, and hence more erect than in Beech. Except in their darker colour, the scales and hairs, &c., resemble those of the Beech.

Leaves alternate, oval to oblong, pointed, slightly oblique, doubly serrate, with prominent pinnate venation, somewhat resembling those of the Elm. Young shoots with conspicuous pink stipules.

Male flowers in pendulous catkins, with thin, ovate-acuminate, ciliated scales, tipped with pink. Female flowers in pairs, in the axils of large, trilobed, beautifully veined bracts, also arranged in pendulous spikes. Flowers in spring. Fruit a nut, in pairs, sessile in the axils of the three-lobed, persistent bracts.

Wood yellowish-white, rather like that of the Beech, but with a number of very broad, dull, false medullary rays. Annual rings sinuous.

Seed (enclosed within the pericarp) exalbuminous. Seedling with a long hypocotyl, supporting the two small, shortly stalked, obovate-cordate, thickish cotyledons,

which are whiter below. First leaves soon formed and typical.

#### 14. HAZEL.

*Corylus avellana* (L.). Cupuliferæ.

Shrub, or small tree, much branched, even at the base. True bark only at the base of old trees, rough and scaly; ordinary cortex, grey to reddish-brown, shining, and abundantly supplied with horizontally elongated lenticels, the thin periderm peeling off in annular strips, like that of the Cherry. Young branches sage-green or reddish, and covered with *glandular* hairs.

Buds short, ovoid, blunt, and somewhat compressed.

Leaves alternate (spiral or distichous), petiolate, obliquely cordate-acuminate and bi-serrate, rough and with prominent venation.

Male flowers in cylindrical, scaly catkins, which are formed in the autumn and persist through the winter. Female flowers in tufts looking like fat buds, but distinguished by the crimson stigmas. Both are exposed long before the leaves are out.

Fruit, the well-known hazel-nut, in an involucre of leafy bracts.

Wood, reddish-white, like Beech, but with broad false rays like Hornbeam.

Seed (enclosed in the pericarp—the shell) exalbuminous, with large fleshy cotyledons, which remain buried. First leaves typical.

## 15. SALLOW.

*Salix Caprea* (L.). Salicineæ.

Shrub or bushy tree, with grey bark, fissured into lozenge-like divisions below; young branches sage-green and hairy, and with a large pith.

Buds moderately large, ovoid, and showing only one scale.

Leaves alternate ovate-oblong, wrinkled with prominent venation and downy below. Rather large, broad, oblique stipules.

Male flowers in ovoid, sessile, silky, stiffly erect catkins, and yellow anthers. Female longer, with conical ovaries. Scales entire in both. Flowers early in spring.

Fruits beaked, very cottony as the minute comose seeds escape.

Wood soft, close, and reddish white. Pith large. Vessels and medullary rays almost invisible.

Seeds very small, with a tuft of silky hairs at base, exalbuminous. Little used, as the Willows are almost invariably propagated by cuttings.

*S. aurita* is somewhat like it, but more bushy, and with more wrinkled obovate (outlines vary) and more downy leaves and conspicuous stipules. The catkins also smaller.

## 16. WHITE WILLOW.

*Salix alba* (L.). Salicineæ.

Distinctly a tree, with young twigs of various shades of yellow and green to purplish. Bark like that of Oak when old.

Buds smaller, longer, and appressed; otherwise like those of *S. caprea*.

Leaves narrow, lanceolate-acuminate, finely serrate. Shining and green above (with a few silky hairs), glaucous beneath. Catkins cylindrical and stalked, otherwise with a general resemblance to those of other Willows. Flowers in spring.

Fruit longer and narrower than *S. caprea*, but the seeds cannot be readily distinguished, nor can the wood except that the heart is browner.

#### 17. CRACK WILLOW.

*Salix fragilis* (L.). Salicineæ.

A tree, very like *S. alba*, but the foliage more decidedly green, and the glandular points of the teeth more distinct. The leaves are also often broader and the catkins somewhat looser.

Wood like that of *S. alba*. Branches snap easily at the joints in spring.

#### 18. OSIER WILLOW.

*Salix viminalis* (L.). Salicineæ.

Shrub, with long flexible, twiggy branches (occasionally a small tree). The twigs smooth, olive to chestnut brown. Grows in wet places.

Buds very small. Leaves very long and narrow, lanceolate, with copious silky hairs beneath. Margins undulated, and nearly or quite entire. Stipules minute



and caducous. Catkins cylindrical, sessile, stiff, silky. Flowers in spring. Style long.

Wood hardly distinguishable from the others.

### 19. WHITE POPLAR.

*Populus alba* (L.). Salicineæ.

Large tree, with grey-green often tomentose twigs. Branches marked with lozenge-shaped cracks, becoming long furrows as the bark forms.

Buds short, conical, brown and scaly; often mealy or tomentose.

Leaves coriaceous, oval to sub-orbicular, with angular lobes and sinuses or teeth, white with cottony hairs below (especially when young), and on round petioles. The leaves of suckers are often larger, 3 to 5-lobed, and more woolly.

Flowers in monœcious, cylindrical greenish catkins, with fimbriated and silky scales. Female catkins at length brown.

Fruits ovoid, smooth, and opening in two valves like the Willows.

Wood soft, white to yellow-brown, with vessels and medullary rays very fine.

Seeds minute, comose. Seedling very small.

### 20. ASPEN.

*Populus tremula* (L.). Salicineæ.

Moderately large tree, with more slender branches than *P. alba*.

Young branches greenish grey or nearly white ; bark longitudinally furrowed.

Leaves not unlike those of *P. alba*, but smaller, rounder, less deeply toothed, thinner, and not tomentose below (though they may be very pale). The leaves of suckers are usually much larger and more irregularly toothed. Petioles slender and compressed.

The catkins are more densely silky, and grey, spotted with red.

Fruits, wood, seeds, &c., not easily distinguished from those of other species.

## 21. BLACK POPLAR.

*Populus nigra* (L.). Salicineæ.

Large tree, with more or less pyramidal crown. (The Lombardy Poplar is a fastigate variety.)

Young branches smooth and grey. Bark of old trees Oak-like, but of a paler hue.

Buds large, angular, pointed and covered with fragrant resin ; the outer scales chestnut-brown and short, the inner projecting to a point. Leaf-scars with three vascular bundles, and three decurrent angles. Many of the lower buds die off.

Leaves large, triangular, ovate acuminate, coarsely crenate-serrate, tough, glabrous, green on both sides, with compressed petioles.

Male catkins red and sessile, female stalked and green-yellow. Structure very similar to the last.

Fruit somewhat turgid.

Wood not markedly distinct from that of the other Poplars.

Seeds and seedlings also resemble those of other species.

## 22. COMMON ELM.

*Ulmus campestris* (Sm.). Urticaceæ.

Tall tree with rounded head and latticed twigs. Twigs with spreading simple hairs. Young branches often with corky ridges (var. *U. suberosa*). Old bark like that of Oak.

Buds small, ovoid-obtuse, dark brown with stiff short hairs. Terminal buds die off each year.

Leaves shortly petiolate, distichous, rough, and coarsely bi-serrate. Variable in shape—ovate to obovate-acuminate. Oblique at the base. Venation prominent.

Flowers small, hermaphrodite, red-brown, in dense clusters, opening before the leaves in early spring.

Fruit flat, obovate, veined, winged at the sides, and deeply notched above, the two stigmas at the points of the notch. One-seeded, and the seed placed above the middle of the fruit.

Wood yellowish to red-brown, with large spring vessels, and those of the autumn wood in peripheral groups. Medullary rays very fine.

Seed exalbuminous, with a straight embryo, rarely ripens in England. Cotyledons small, obovate, on a slender hypocotyl. First leaves oblong acuminate, coarsely serrate.

## 23. WYCH ELM.

*Ulmus montana* (Sm.). Urticaceæ.

Difficult to distinguish from the last, but usually a more spreading tree, with larger leaves, and the fruit more oval, with a central seed, to which the incision does not extend.

Wood, seed, &c., much as in *U. campestris*.

## 24. FIELD MAPLE.

*Acer campestre* (L.). Sapindaceæ.

A small tree, or bush; the young branches covered with corky wings, often very prominent, older ones with fissured, red-brown, corky bark.

Buds small, and, like the young shoots, hairy.

Leaves smaller than those of the Sycamore, with three to five blunt and sinuous lobes with deep depressions between. Slightly pubescent, especially at the angles of principal ribs.

Flowers few, in lax erect corymbs.

Fruit with the long axes of the two wings nearly in a straight line.

Wood with a pinker hue than the Sycamore.

Seeds and seedlings very like the Sycamore, but the first leaves are finely ciliated at the margins.

## 25. SYCAMORE.

*Acer pseudo-platanus* (L.). Sapindaceæ.

Large tree, with dull yellowish to greyish-brown cortex, smooth till late in life. Bark scaly, throwing

off irregular plates somewhat like those of *Platanus*, but smaller, exposing yellowish-white patches.

Buds ovoid, pointed, obtusely four-angled, rather large. Scales imbricated, decussate, pale green with dark brown edges. Leaf-scars narrow crescentic, with three vascular bundle traces.

Leaves decussate, large, palmately five-lobed, cordate at base, unequally and coarsely serrate; dark green above, greyish below and with prominent venation. Petioles long, and not covering the axillary buds.

Flowers yellow-green, in loose, pendulous racemes; male and hermaphrodite flowers mixed. Late spring.

Fruit a double samara, heart-shaped and silky hairy when young. The two wings of the ripe fruit have the inner margins nearly parallel, the stiff outer ribs nearly erect.

Wood pale yellow-white, with numerous equally distributed small vessels, and straight satiny medullary rays. Annual rings sharply marked.

Seeds exalbuminous; the cotyledons rolled up and green. Hypocotyl slender, raising the long, oblong, almost parallel veined cotyledons. First leaves ovate, cordate, serrate.

## 26. NORWAY MAPLE.

*Acer platanoides* (L.). Sapindaceæ.

Large tree, somewhat resembling the last but with a redder tinge to the young branches, and more numerous fine furrows in the bark, which is not cast off in distinct plates.

The buds are shorter, smaller, and usually dirty red

in colour, and the axillary ones appressed to the branches.

The leaves are usually larger than those of the Sycamore, and thinner, greener, and more glabrous; also more deeply five to seven-lobed, and the segments sharply pointed, the petiole longer and more slender.

Flowers larger, and in erect corymbs; the petals spreading and delicate in texture.

Fruits with the wings diverging at an angle of  $45^{\circ}$  or more.

Wood almost undistinguishable from that of the Sycamore.

Seed and seedling much as before, but the cotyledons crack across, and the first leaves are slightly lobed and not serrate.

## · 27. LIME-TREE.

*Tilia europea* (L.). Tiliacæ.

Large tree with rounded crown. Bark of old trees grey and resembles that of Oak; twigs and young branches smooth, varying from red-brown to green-yellow.

Buds rather large, ovoid, obtuse, smooth, showing two or three scales only, and of the same colour as the twigs. The terminal bud often abortive each year. Leaves on long petioles, alternate, obliquely cordate-acuminate, serrate, glabrous or nearly so.

Flowers small, greenish-yellow, odorous; in long-stalked, pendulous corymbose cymes, among the leaves

in July. A long membranous bract is fixed by half its length to the peduncle.

Fruits globoid, grey, hairy, nut-like.

Wood reddish-white, with very small vessels equally distributed, and sharp, fine, medullary rays. The cortex shows large bast bundles in transverse section.

Seeds small, with oily endosperm, and straight embryo. Cotyledons large, palmately lobed, and raised above the soil by a long hypocotyl. The first leaves resemble those of the Sycamore.

## 28. ASH.

*Fraxinus excelsior* (L.). Oleaceæ.

Large tree, with straight grey twigs, and deeply fissured Oak-like bark.

Buds in winter very characteristic; conical, velvety-black. The terminal one large, the lateral (occasionally with accessory buds) smaller, and superposed on crescent-shaped leaf-scars.

Leaves compound, decussate, impari-pinnate; leaflets seven to eleven, sessile, ovate-lanceolate, serrate.

Flowers in erect axillary panicles; hermaphrodite, but monochlamydeous. Anthers purple. Flowers in spring before the leaves open.

Fruit a one-seeded samara, with a long, thin, veined wing.

Wood: the alburnum is very broad and yellowish-white; heart-wood Oak-like. Vessels of spring-wood large, the smaller ones of the autumn-wood tailing off in radial lines. Medullary rays hardly visible.

Seed broad, flat, striated ; with a straight embryo, in oily endosperm. Cotyledons shortly stalked, oblong, and with the secondary ribs running towards the margin, elevated on a long hypocotyl.

First leaves paired, simple, ovate, serrate ; the succeeding leaves decussate, and gradually pass through ternate to pinnate forms.



# INDEX.

---

## A.

- Abies pectinata*, notes on, 283, 324  
 Accumulations of humus, treatment of, 31  
*Acer*, notes on, 259, 340  
 Adjoining woods, natural regeneration from, 161  
 Advance growth in group system, 155  
 Advantages of loosening soil, 49  
 „ of regular planting, 78  
 „ thinning, 218  
 Age of plants, 74  
 Age of seed, 43  
**Alder**, notes on, 263, 328  
*Alnus glutinosa*, notes on, 263, 328  
*Ammophila arenaria*, 36  
 Area of nursery, 99  
 Arid land, irrigation of, 30  
 Artificial formation of woods, 40, 41  
 „ *versus* natural formation, 175  
**Ash**, notes on, 248, 343  
**Aspen**, „ 275, 337  
**Austrian Pine**, notes on, 303, 326

## B.

- Balls of earth, planting with, 118  
 „ „ „ without, 120  
**Baltic Pine**, 290, 296  
 Bed, germinating, 49  
**Beech**, notes on, 230, 332

- Betula alba*, notes on, 267, 329  
**Birch**, „ „ 267, 329  
 Bituminous humus, 32  
**Black Pine**, notes on, 303, 326  
 Bogs, peat, 31  
**British forest trees**, notes on, 229, 323  
 Broadcast sowing, 56  
 Broom, 36

## C.

- Carex arenaria*, 36  
*Carpinus Betulus*, notes on, 237, 333  
*Castanea vesca*, „ „ 256, 331  
 Causes of swampiness, 23  
 Change of species, 10  
**Chestnut, sweet**, notes on, 256, 331  
 Choice between art. and nat. formation, 175  
 „ „ seedlings and transplants, 113  
 „ „ sowing and planting, 170  
 „ of fence, 19  
 „ method of formation, 169  
 „ site of nursery, 98  
 „ species, 4, 41, 71  
 Circular spade, 86  
 Cleaning young woods, 196  
 Cluster Pine, 36  
 Coast dunes, 33  
 Cockchafer, in nurseries, 115  
 Cold winds, protection against, 193  
 Combinations of fences, 19

Combinations of methods of formation, 178  
 „ „ sowings, 69  
 Commencement of thinnings, 213  
 Compartment system of nat. regeneration, 135, 158  
 Conditions of germination, 48  
 „ success in planting, 70  
 „ „ sowing, 41  
 Coppice woods, thinning of, 218  
*Corylus Avellana*, notes on, 281, 334  
 Covering seed, 53, 61  
 Crowded woods, tending of, 198

## D.

Dangers of pruning, 202  
 Dead trees, removal of, 199  
 Degree of thinning, 214  
 Density of planting, 76  
 „ proper, of crop, 195  
 Dibbling, 66  
 Direct sowing, 41  
 „ „ versus planting, 170  
 Distribution of plants over area, 77  
 Ditches, as fences, 15  
 „ for drainage, 27  
 Diversion of excess water, 24  
**Douglas Fir**, notes on, 316, 325  
 Drainage, 25  
 Draining of nursery, 100  
 Drought, protection against, 192  
 Dry mould, 32  
 Dunes, coast, 33  
 „ inland, 37  
 „ littoral, 34

## E.

**Elm**, notes on, 252, 339  
*Elymus arenarius*, 36  
 Even-aged mixed woods, 181  
 Excess water, diversion of, 24  
 Execution of pruning, 204

Execution of thinning, 220  
 External dangers, protection against, 192

## F.

*Fagus sylvatica*, notes on, 230, 332  
 Fencing, 12  
 „ of nursery, 100  
 Final stage of nat. regeneration, 144  
**Fir, Douglas-**, notes on, 316, 325  
 „ red, 316  
 „ **Silver**, notes on, 283, 324  
 Fire, protection against, 192  
 Fixation of shifting sands, 33  
 „ unstable soil on slopes, 38  
 Formation and tending of woods, 1  
 „ choice of method of, 169  
 „ of mixed woods, 180  
 „ woods, 40  
*Fraxinus excelsior*, notes on, 248, 343  
 Frost, protection against, 192  
 Fungi, protection against, 194  
 Furrows, sowing in, 64  
 Furze, 36

## G.

Germinating bed, 49  
 Germination, conditions of, 48  
 „ of seeds, percentage of, 45  
 Group system, 152, 160  
 Growing space, suitable, 208

## H.

**Hazel**, notes on, 281, 334  
 Hedges, 12  
 High-class timber, production of, 215

Hoe, planting with, 120  
 Holes, sowing in, 66  
**Hornbeam**, notes on, 237, 333  
 Humus, 32

I.

Impermeable substratum, 21  
 Injured trees, removal of, 199  
 Inland dunes, 37  
 Insects, protection against, 194  
 Irrigation of arid land, 30  
 Isolation of trees, 224, 225

K.

Kinds of plants, 71

L.

Larch, as overwood, 227  
 ,, notes on, 309, 326  
 Large timber, production of, 221  
*Larix europæa*, notes on, 309, 326  
 Layers, planting with, 130  
 Laying out nursery, 104  
 Lifting plants, 86  
**Lime-tree**, or Linden, notes on, 278, 342  
 Line planting, 77  
 Littoral dune, 34  
 Loosening soil, merits of, 49

M.

Manuring, in nurseries, 102  
**Maple**, notes on, 259, 340  
 Marking of planting spots, 80  
 Marking trees, nat. regeneration, 149  
 Marram grass, 36, 37  
 Method of formation, choice of, 169  
 Methods of planting, 117  
 Methods of sowing, 56

Mixed woods, even-aged, 181  
 ,, ,, formation of, 180  
 ,, ,, thinning of, 217  
 ,, ,, uneven-aged, 185  
 Mixture, preservation of a proper, 197  
 Mound planting, 128  
 Mounds, sowing on, 69

N.

Natural formation or regeneration of woods, definition, 40  
 Natural regeneration of woods, 132  
 ,, ,, by seed 132  
 ,, ,, by shoots and suckers, 164  
 ,, ,, compartment system, 135  
 ,, ,, from adjoining woods...161  
 ,, ,, group system, 152  
 ,, ,, selection ,, 157  
 ,, ,, strip ,, 150  
 ,, ,, systems compared, 158  
 ,, ,, under shelter-woods, 132  
 Natural *versus* artificial formation, 175  
**Norway Spruce**, notes on, 290, 323  
 Notching, 126  
 Number of plants required, 84  
 Nurseries, raising plants in, 97  
 Nursery, area of, 99  
 ,, choice of site of, 98  
 ,, choice between seedlings and transplants, 113  
 ,, draining of, 100  
 ,, fencing of, 100  
 ,, laying out of, 104  
 ,, manuring of, 102  
 ,, preparation of soil of, 101

- Nursery, pricking out of plants, 109  
 „ quality and quantity of seed, 108  
 „ shape of, 99  
 „ sowing seed-beds, 105  
 „ tending, 114  
 „ watering, 100  
 „ weeding, 116
- O.
- Oak, as overwood, 226  
 „ notes on, 241, 330  
 Objects of pruning, 200  
 Open woods, forms of treatment, 223  
 „ „ tending of, 221
- P.
- Palings, wooden, 14  
 Pan, 21  
 Partial sowing, 62  
 Patches, sowing in, 64  
 Peat bogs, 31  
 Peg, planting with, 123  
 Percentage of germination of seeds, 45  
*Picea excelsa*, notes on, 290, 323  
 Pine, Baltic, 290, 296  
 „ black or Austrian, notes on, 303, 326  
 „ red, 296  
 „ Scotch, notes on, 296, 325  
 „ Weymouth, notes on, 306, 327  
 „ white, 290, 306  
*Pinus Laricio*, var. *Aust.*, notes on, 303, 326  
 „ *Pinaster*, 36  
 „ *Strobus*, notes on, 306, 327  
 „ *sylvestris*, notes on, 296, 325  
 Pits, sowing in, 67  
 Planting, 70  
 „ advantages of regular, 78
- Planting, density of, 76  
 „ general rules for, 117  
 „ in lines, 77  
 „ „ quincunx figures, 78  
 „ „ squares, 77  
 „ „ triangles, 77  
 „ on mounds, 128  
 „ season for, 74  
 „ spots, marking of, 80  
 „ versus direct sowing, 170  
 „ methods of, 117  
 „ with balls of earth, 118  
 „ „ hoe or spade, 120  
 „ „ peg or staff, 123  
 „ „ slips, layers, or suckers, 129  
 „ without balls of earth, 120
- Plants, age of, 74  
 „ distribution of, over area, 77  
 „ from existing woods, 96  
 „ in transit, protection of, 92  
 „ kinds of, 71  
 „ lifting of, 86  
 „ number of, 84  
 „ pricking out of, 110  
 „ pruning of, 90  
 „ purchase of, 95  
 „ quality of, 72  
 „ raising of, 94  
 „ size of, 74
- Pollarding, 168  
 Poplar, notes on, 275, 337  
*Populus*, notes on, 275  
 Power of accommodation of species, 9  
 Practical Sylviculture, definition of, 3  
 Preliminary works, 4  
 Preparation of seed-beds, 137  
 „ of soil for sowing broadcast, 56  
 „ of soil in nurseries, 101  
 „ of soil for planting, 94  
 Preparatory stage, nat. regeneration, 136

Pricking out plants, 110  
 Production of high-class timber,  
     215  
     ,, of large timber, 221  
     ,, of quantity, 213  
 Prolongation of regeneration-period,  
     224  
 Protection of plants in transit, 92  
 Pruning, 200  
     ,, execution of, 204  
     ,, dangers connected with,  
        202  
     ,, objects of, 200  
     ,, plants in nurseries, 90  
*Psamma arenaria*, 36  
*Pseudotsuga Douglasii*, notes on, 316,  
     325  
 Purchase of plants, 95

## Q.

Quality of plants, 72  
     ,, of seed, 41, 108  
 Quantity of seed, 46, 108  
     ,, production of, 213  
*Quercus*, notes on, 241, 330  
 Quincunx planting, 78

## R.

Raising level of ground, 29  
 Raising plants, 94  
     ,, in nurseries, 97  
 Reclamation of the soil, 20  
 Red fir, 316  
 Red lead, coating seeds with, 114  
 Regeneration, artificial, 41  
     ,, by planting, 70  
     ,, ,, shoots and suckers,  
        164  
     ,, ,, sowing, 41  
     ,, choice of method, 169  
     ,, combination of me-  
        thods, 178  
     ,, natural, 132  
     ,, of mixed woods, 180

Repetition of thinnings, 214  
 Ridges, sowing on, 69  
 Rules, general, for planting, 117

## S.

*Salix*, notes on, 271  
**Sallow**, notes on, 335  
*Sarothamnus scoparius*, 36  
 Scotch Pine, as overwood, 227  
**Scotch Pine**, notes on, 296, 325  
 Season for planting, 74  
 Seed, age of, 43  
     ,, coating of, with red lead, 114  
     ,, covering of, 53, 61  
     ,, for nurseries, 109  
     ,, percentage of germination of,  
        45  
     ,, quality of, 41  
     ,, quantity of, 46  
     ,, size of, 42  
     ,, source of, 43  
     ,, sprouting of, 54  
     ,, testing of, 44  
     ,, weight of, 42  
 Seed-beds, preparation of, 137  
     ,, tending of, 114  
 Seeding-stage, nat. regeneration,  
     141  
 Seedling plants, definition of, 72  
 Seedlings, choice between, and  
     transplants, 113  
 Selection of groups, group system,  
     154  
 Selection system, 157, 161  
 Semi-circular spade, 88  
 Semi-conical spade, 89  
 Shape of nursery, 99  
 Shelterwoods, nat. regeneration  
     under, 132  
 Shifting sands, fixation of, 33  
**Silver Fir**, notes on, 283, 324  
 Size of plants, 74  
     ,, of seeds, 42  
 Slips, planting with, 129  
 Soil, advantages of loosening of, 49

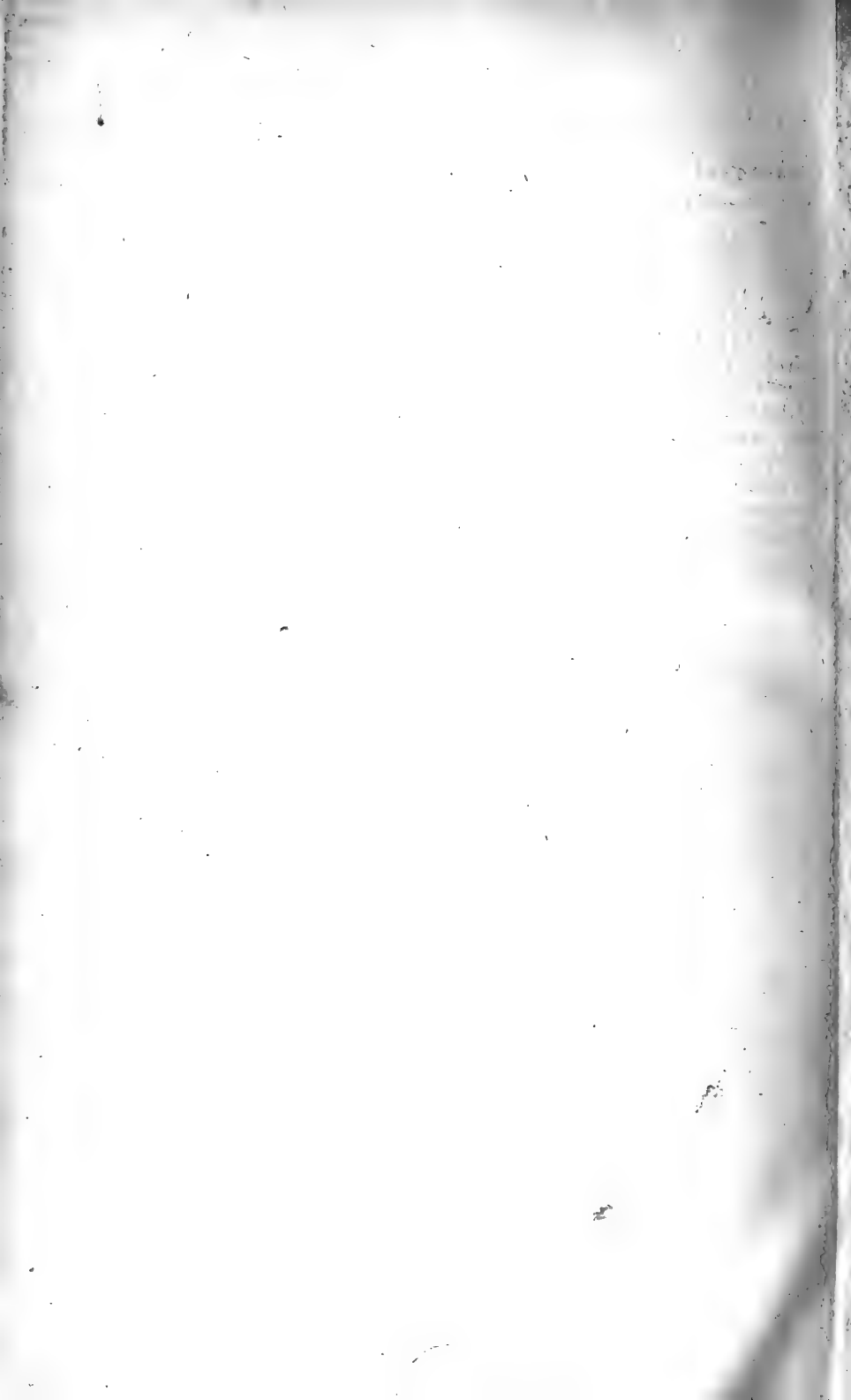

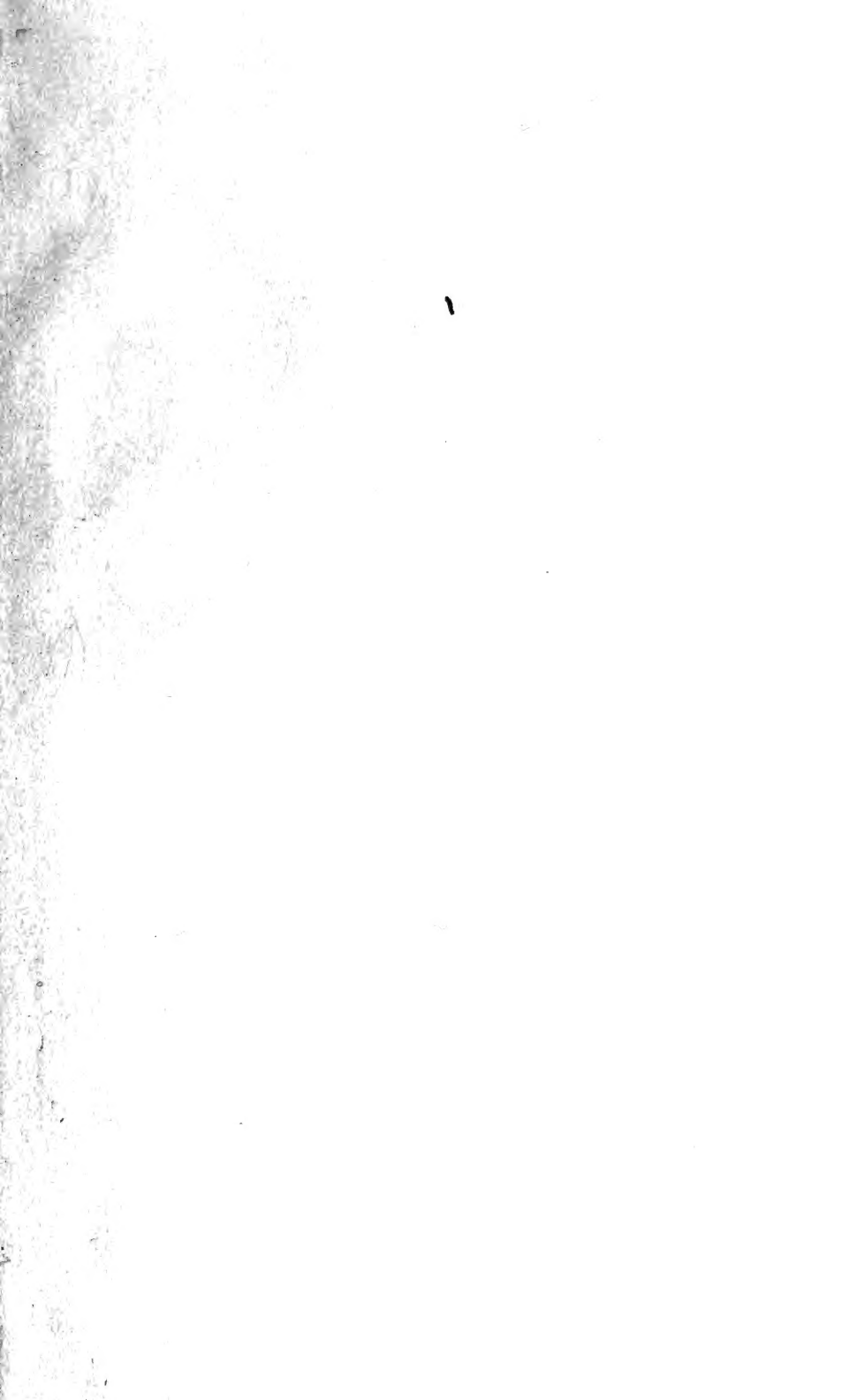





CA

UN

MAR 26 1992

