

SB

5-1

3-1



Class \_\_\_\_\_

Book \_\_\_\_\_

Copyright No. \_\_\_\_\_

COPYRIGHT DEPOSIT.









**THE WILEY TECHNICAL SERIES**

FOR

VOCATIONAL AND INDUSTRIAL SCHOOLS

EDITED BY

JOSEPH M. JAMESON

GIRARD COLLEGE

## THE WILEY TECHNICAL SERIES

EDITED BY

JOSEPH M. JAMESON

### TEXT BOOKS IN AGRICULTURE

*NOW READY*

**Market Gardening.** By F. L. YEAW, Manager, Oasis Farm and Orchard Company, Roswell, N. M. Formerly Professor of Market Gardening, Massachusetts Agricultural College. vi+120 pages, 5 by 7. 36 figures. Cloth, 75 cents net.

**Studies of Trees: Their Diseases and Care.** By J. J. LEVISON, Department of Parks, Brooklyn, N. Y. 5¼ by 8. x+253 pages, 156 half-tone illustrations. Cloth, \$1.60 net. (Also 8 by 10½, loose leaf.)

**Agricultural Drafting.** By CHARLES B. HOWE, Bushwick Evening High School, Borough of Brooklyn, New York, N. Y. viii+63 pages, 8 by 10¼. 45 figures, 26 plates. Cloth, \$1.25 net.

**Exercises in Farm Dairying.** By Professor C. LARSEN, Department of Dairy Husbandry, South Dakota State College. Loose leaf, 8 by 10½. 69 Exercises. Single Exercises two cents each. Complete, \$1.00 net.

*READY IN SEPTEMBER, 1915*

**Farm Crops and Soils.** By Professor A. G. McCALL, Ohio State University.

**Agricultural Chemistry.** By Professor T. E. KEITT, Clemson Agricultural College.

**Injurious Insects.** By DEAN E. D. SANDERSON and Professor L. M. PEAIRS, West Virginia University.

For full announcement see list following index.

1M. 6/10/15



# MARKET GARDENING

BY

F. L. YEAW

Manager, Oasis Farm and Orchard Company, Roswell, New Mexico  
Formerly Professor of Market Gardening,  
Massachusetts Agricultural College

*FIRST EDITION*

FIRST THOUSAND

NEW YORK

JOHN WILEY & SONS, INC.

LONDON: CHAPMAN & HALL: LIMITED

1915

SECRET  
-YEA-

Copyright, 1915

BY

F. L. YEAW



THE SCIENTIFIC PRESS  
ROBERT DRUMMOND AND COMPANY  
BROOKLYN, N. Y.

JUN 25 1915

© 1915 A 401517

## PREFACE

---

THE income from the sale of vegetables is practically twice that produced from the great fruit industries of the country. Only recently, however, is Market Gardening receiving the attention that it merits as a subject in which valuable instruction may be given in our schools.

The purpose of this little manual is to furnish, in a condensed and usable form, information concerning methods and best practices for growing and marketing the commoner vegetables. It is designed primarily for use as an elementary text on market gardening.

Methods for the propagation, preparation of the soil for, planting, cultivation, harvesting and marketing of twenty-three of the more common and hardy vegetables are considered in detail. In addition, such information is given concerning soils, fertilizers, moisture requirements, seeds, germination, the preparation and care of hot beds and the storing and packing of vegetables as is necessary to a reasonably complete understanding of the whole problem. A special chapter is devoted to the location, planning and care of home and school gardens.

Growers of vegetables in a small way for the home table, as well as those engaged in market gardening on a commercial scale, it is believed, will find this a practical, reliable and handy guide.

F. L. YEAW.

ROSWELL, N. M.  
April, 1915.



# CONTENTS

---

## CHAPTER I

### LOCATION FOR THE MARKET GARDEN. CULTIVATION

	PAGE
Market—Soil—Exposure—Labor—Water—Tools—Cultivation. . .	1

## CHAPTER II

### FERTILIZERS

Stable Manures—Composting—Chemical Fertilizers—Nitrogen—Nitrate of Soda—Potash—Phosphoric Acid—Complete Fertilizers—Soil Acidity—Lime—Green Manures—Legumes—Ploughing Under—Catch Crops. . . . .	9
--	---

## CHAPTER III

### HOT BEDS

Uses—Location—Means of Heating—Construction—Preparation of the Manure—Care. . . . .	19
---	----

## CHAPTER IV

### SEEDS AND SEED SOWING. TRANSPLANTING

Quality of the Seed—Germination—Seed Beds—Planting—Transplanting. . . . .	24
---	----

## CHAPTER V

### IRRIGATION

Moisture Requirements of Plants—Methods of Irrigation. . . . .	32
--	----

## CHAPTER VI

## VEGETABLE GARDENS

	PAGE
The Home Garden—School Gardens. . . . .	36

## CHAPTER VII

## STORING AND PACKING

Storage Cellars and Pits—Storing Root Crops—Celery—Onions and Cabbage—Packing. . . . .	43
---	----

## CHAPTER VIII

## CROPS

Propagation, preparation of soil for, planting, cultivation, harvest- ing and marketing of the following: 1. Asparagus. 2. Beans.— 3. Beets.—4. Cabbage.—5. Brussels sprouts.—6. Cauliflower.— 7. Celery.—8. Cucumbers.—9. Dandelion.—10. Egg Plant.— 11. Horse-radish.—12. Lettuce.—13. Muskmelon.—14. On- ions.—15. Parsnips.—16. Salsify.—17. Pea.—18. Radish.— 19. Rhubarb.—20. Spinach.—21. Squash.—22. Sweet corn.— 23. Tomatoes. . . . .	53
--	----

# MARKET GARDENING

## CHAPTER I

### LOCATION FOR THE MARKET GARDEN. CULTIVATION

THE location of the market garden is determined by a number of factors, the most important of which are market, soil, transportation facilities, labor supply, manure supply and water.

**1. Market.** The market, and nearness to market, are of first importance in choosing the location for the market garden. The grower must have a sure and dependable market for his products; the larger cities generally afford the steadiest and most dependable markets. Most of the products of the market garden are of a perishable nature; if the garden is not located close to a market, within hauling distance, the express or fast freight service must be efficient and dependable. The condition of the roads is of vital importance to the grower who intends to haul his produce to market with a team or auto truck.

**2. Soil.** The soil is of secondary importance to the market. A market must be had in which to dispose of the produce; but a good gardener can build up and improve the average soil so that it will produce good crops of most vegetables, while it might be impossible to create or build up a market.

The ideal market garden soil is a good *sandy loam*, under laid by a *gravelly subsoil*. Such a soil warms up quickly in the spring, never bakes or puddles, can be worked soon after a rain, can be worked early in the spring, is well drained and is adapted to a wide range of crops.

**3. Exposure.** The land should slope to the south or southeast. Such an aspect assures the earliest warming up in the spring, is protected from cold north winds and receives the greatest amount of sunshine.

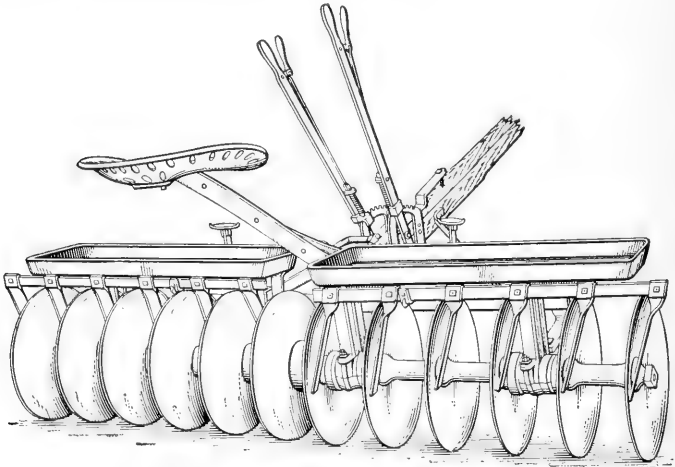

FIG. 1.—Disc Harrow.

*Windbreaks* are desirable and may be temporary or permanent. Temporary wind breaks may be built by sticking brush into the ground or constructing a tight board fence along the exposed side. A more permanent wind-break is to be had by planting trees close together along the exposed side; this will, in time, form a compact hedge which is very efficient in breaking the wind.



**4. Labor.** The market gardener is dependent upon a quickly available and cheap supply of labor. The large

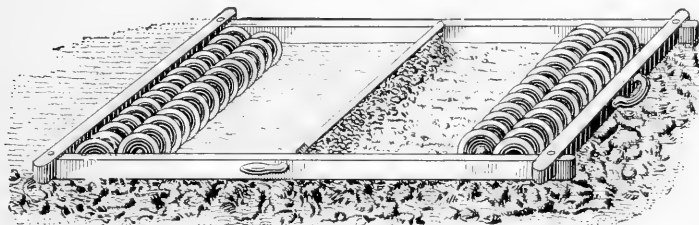

FIG. 2.—The Meeker Smoothing Harrow.

cities are the sources of such a supply of labor. Intensive gardening must be done very largely by hand and a large

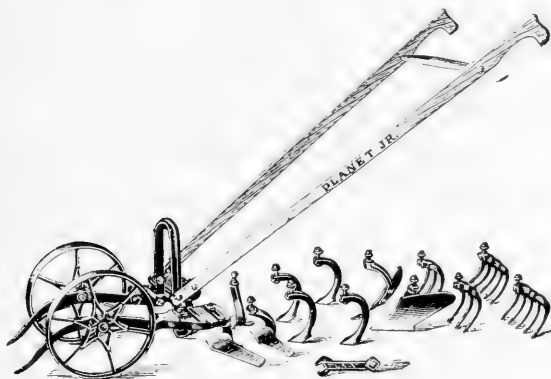

FIG. 3.—Double Wheel Hoe.

number of hands must be available, for a few months' time during the year, for the successful carrying on of the intensive market garden. The larger cities also furnish a large



FIG. 4.—Wheel Hoes in Use in a School Garden.

supply of horse manure which is most important in market gardening.

**5. Water.** A market garden is not completely equipped unless it has an abundant supply of water for irrigating the crops and for the preparation of the vegetables for market. The gardener should not depend upon the rainfall for the success of his garden. It is essential that water be available for irrigation whenever the conditions demand it. Practically every kind of vegetable is washed when being prepared for market and a good supply of pure water is necessary for this work.

**6. Preparation of the Soil.** After the manure has been applied, the ground should be well ploughed. Four to six inches is sufficient depth for ploughing in most cases; too deep ploughing is not advisable because new soil is brought to the surface which will take a number of seasons to come to a proper condition for the growing of vegetables. Following the ploughing, the soil should be thoroughly disced. A double cut-a-way disc harrow is the best tool to break up lumps and with which to get the soil into its best condition for the planting of garden crops. The discing should be followed by an application of a high grade chemical fertilizer which should be mixed with the top soil by the use of a peg tooth smoothing harrow or by the use of a Meeker disc smoothing harrow.

When the soil is of an usually poor quality or is somewhat heavy and lumpy, it is advisable to follow the first discing with the plough. It may be necessary to plough the ground three times to get it into proper condition for such a crop as lettuce. The first and last ploughings may be shallower than the second ploughing when three ploughings are made.

**7. Cultivation.** The vegetable garden must have frequent and thorough, but shallow, cultivation. Most vege-



FIG. 5.—Hand Seeder in Use in a Family Garden.

tables do not root deeply but send their roots out quite near the surface. The cultivation, if carried on too deep close to the plants, is liable to injure the roots. The object of frequent cultivation is to keep down the weeds and to maintain a dust mulch for the conservation of the water held in the soil. Cultivation lets the air and sunlight into the soil thereby favoring the development of certain beneficial bacteria and helping to make available the plant food applied to the soil.

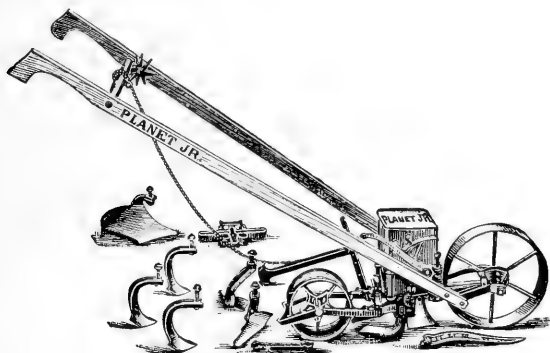

FIG. 6.—Combined Hill and Drill Seeder and Wheel Hoe.

For the use of the seed drill the soil must be in a smooth, mellow condition, free from lumps or coarse material that would interfere with the planting or with keeping the rows straight. The Meeker smoothing harrow, Fig. 2, is the best tool on the market for finishing the ground previous to drilling in the seed. This harrow consists of four rows of small discs, placed close together, two rows in front and two rows behind with a smoothing plank in the middle. This harrow will leave the surface in as fine condition as though the ground had been hand raked.

When the rows are close together and hand work must be employed, the choice of tools will largely determine the cost of the cultivation. The two-wheel and single-wheel hoes are commonly used in cultivating the smaller vegetable crops. The two-wheel hoe is designed and intended to run straddle of the row with a wheel each side and close to the plants. The various teeth and cutters furnished with the double or single-wheel hoes are adjustable so that the cultivation may be very close or farther from the plants. The single-wheel hoe is designed for use between the rows. There are a number of combination seed drills and wheel hoes on the market which are very desirable for the small grower, the cost of the combined tool being but little more than the cost of the seed drill alone. The best makes of the combination tools allow for the elimination of the seed drill or wheel hoe attachments as may be desired. Others make it necessary to use both the seed drill and the wheel hoe attachments at the same time; the drill simply being thrown out of gear and the teeth attached.

## CHAPTER II

### FERTILIZERS

**8. Kinds.** There are three general sources of fertilizer, or plant food; *stable manures*, *chemical fertilizers* and *green manures*. The term "green manure" is used to designate such crops as cow peas, crimson clover, rye and other green crops grown for ploughing under. Such crops add *humus* to the soil and, when a leguminous crop is ploughed under, a considerable amount of nitrogen is also added to the soil. Green crops are usually ploughed under in the spring although it is often desirable to plough the crop under in the fall.

**9. Stable Manures.** Stable manures are more generally used than any other source of plant food for growing vegetables. In many instances, they are the cheapest source of plant food obtainable, as when the grower is located near a large city and the stable manure may be had at small cost or for hauling it away. In other instances, manure brings a good price and is often shipped long distances for the market gardener. Rotted stable manure is the best fertilizer for the garden, for not only is a supply of quickly available plant food added, but stable manure also furnishes a store of humus in its most desirable condition for readily incorporating with the soil. Stable manure runs comparatively low in its plant food value. It is estimated that a ton of partly rotted stable manure is worth about \$2.00 for the plant food contained in it; it is of course worth more than this to the gardener because of its supply of humus.

**Humus**, or rotted vegetable matter, is indispensable for the successful growing of vegetables or any other crop. Humus makes the soil more friable, helps it to hold moisture, lightens a heavy soil and makes more retentive a light soil.

A soil deficient in humus is hard to work, bakes quickly after a rain, is slow to warm up in the spring and is very unfavorable for the use of chemical fertilizer. If humus is not present in a soil, the chemical fertilizer applied will largely be lost. The addition of humus renders the soil fit for the use of chemical fertilizers, and furnishes a condition favorable for certain chemical changes which constantly go on in the soil, and for certain friendly bacteria.

Other manures used in vegetable growing are sheep manure, hen manure, cow manure and hog manure. Hen and sheep manures are rich in nitrogen and their store of plant food is quickly available; they are valuable for use as a top dressing or for crops requiring unusual amounts of nitrogen. They are "hot" manures and must be used with care else the crops may be damaged by burning. Cow and hog manure are cold manures, their content of plant food is slow to become available except when they are well rotted.

**10. Composting.** It is not generally desirable to apply fresh horse manure to land intended for growing vegetables. Fresh manure tends to the production of top at the expense of the root in many crops. The general practice in using stable manure is to compost it for a considerable time before applying it to the soil. Rotted or partly rotted stable manure has its store of plant food in a quickly available condition, which is very desirable in growing vegetables. The plant food contained in fresh manure is not so quickly available except the nitrogen in the form of ammonia.



Stable manure is composted by making the manure into a pile as soon as it is hauled to the market garden. Manure is generally hauled as fast as it is produced and is then built up into piles conveniently located for final distribution. The pile should be about five feet high and as long and wide as necessary. As the pile is constructed, the manure should be firmed by tramping, and if very dry, the manure should be wetted sufficiently to prevent burning in the pile. When fresh horse manure is placed in a pile, fermentation takes place with a considerable amount of heat. The heat will cause the manure to *fire fang*, or burn. The pile should be examined frequently, and if it is showing a whitish or grayish color, the pile should be turned and watered lightly. It should be remembered that every time the pile is turned there is a consequent loss of nitrogen in the form of ammonia; therefore handle the pile carefully and do not disturb it more often than is absolutely necessary. About six months time is ordinarily required for the proper composting of the manure.

Rotted stable manure is usually applied in the spring just previous to ploughing. After ploughing the ground should be thoroughly worked with a disc harrow. Fresh or partly rotted manure is best ploughed under in the fall; the procedure in the spring then is to thoroughly disc the ground before planting.

The rate of application of manure depends upon the condition of the ground and the crops to be grown. In intensive gardening, where the ground is not allowed to be idle during the growing season, from twenty to fifty cords of rotted manure per acre should be ploughed under each season. The average application is twenty to twenty-five cords.

**11. Commercial Fertilizers.** Commercial fertilizers are

necessary for the maximum production from the area planted. Stable manures alone may furnish sufficient plant food for some classes of vegetables, but being unbalanced in their content of plant food, their use cannot be depended upon entirely for the successful growing of all vegetables. Manures have a relatively high content of nitrogen, and are usually deficient in the mineral elements of phosphorous and potash. To balance the ration of plant food, chemical fertilizers are used.

The plant food contained in manures becomes available rather slowly, except for the nitrogen which is in the organic form, ammonia. This becomes available very quickly, particularly if the manure is rotted.

Chemical fertilizers may be obtained in forms which are quickly available. This is important in intensive gardening where quick results are very desirable. Slow plant growth results in vegetables of inferior quality and oftentimes the yield is small in quantity. Slow growth tends to produce vegetables tough in texture and of poor flavor. Rapid growth produces tender, succulent vegetables of fine flavor. Then again, the more quickly a crop may be matured, the sooner it will become ready for harvesting and thus out of the way for succeeding crops. The use of chemical fertilizers enables the grower to raise a maximum crop of fine flavor and quality, and to produce the crop in the shortest time possible.

Chemical fertilizers should seldom be used alone; they give the best results only when used as an adjunct to stable manures. To get the largest results from an application of chemical fertilizers, the ground must be liberally supplied with humus, and must be in a high state of cultivation.

**12. Nitrogen.** The element necessary in the production of tender succulent stems and leaves is nitrogen, and it is

therefore very valuable in the growing of such crops as celery, cabbage, lettuce, spinach, asparagus, or any crop grown for its top, or for early maturity. Nitrogen stimulates the plants and tends to produce a good growth in the early spring before the ground becomes thoroughly warmed.

**13. Nitrate of Soda.** The most available and therefore valuable form in which nitrogen may be supplied is known as nitrate of soda. The nitrogen becomes available as soon as the compound is dissolved, while if supplied in manures, dried blood, bone or tankage, these materials must decompose before their supply of nitrogen becomes available.

Nitrate of soda may be supplied alone or in combination with other elements. The rate of application varies with the richness of the soil and with the kind of crops grown. The method of application varies with the conditions; whether it is used as part of a complete fertilizer, or is used alone as a top dressing. Under most conditions the best results are obtained from sowing the nitrate broadcast, even when the plants are young and tender. If the foliage is dry at the time of broadcasting the nitrate of soda, none of it will adhere to the leaves but all will glance off to the ground.

Nitrate of soda may also be sown along the row quite close to the plants and then cultivated in, or it may be applied by any one of the numerous fertilizer distributors that are adapted for use in narrow rows.

Nitrate of soda is used as a part of complete fertilizers for vegetables. Such fertilizers should be broadcasted over the land, or applied with a fertilizer drill just preceding the final harrowing before seed sowing, or placed in the hill, or drill, at the time of planting. The amount of nitrate of soda to be used at one time will vary with the richness of

the soil and with the character of the crop to be fertilized. The amount varies from a few pounds to as much as 250 pounds per acre. It is the better practice to make smaller and frequent applications rather than to make larger and fewer applications.

**14. Other Sources of Nitrogen.** Nitrogen may also be obtained from the use of dried blood, tankage, manures, raw or steamed bone and ground fish. Dried blood decomposes quite rapidly and its supply of nitrogen becomes available quickly. Tankage decomposes somewhat more slowly than does dried blood. Manures, raw bone and steamed bone decompose slowly. Ground fish becomes available slowly.

The supply of nitrogen in a complete fertilizer should have at least two sources, nitrate of soda, and another source such as dried blood or tankage.

**16. Potash.** Potash is particularly necessary in growing root crops, as carrots, turnips, beets, radishes, and parsnips. It is also important in growing other vegetable crops. Sandy or muck soils are usually very deficient in their supply of this element.

Potash is obtainable in several forms, muriate of potash being the most available form. Sulphate of potash is also a desirable form.

**17. Phosphoric Acid.** As most soils are deficient in phosphoric acid, the gardener must supply this element of plant food in some form. Phosphoric acid is very important in the growth of nearly all vegetable crops, the cereals being particularly benefited by it. A deficiency of phosphoric acid is indicated by small yields and the slow maturity of the crops.

Phosphoric acid is derived from several sources, the most important being Rock Phosphate, Thomas Slag, raw and

steamed bone and tankage. The rock phosphates are the principal source of phosphoric acid for use in gardening.

**18. Complete Fertilizers.** Fertilizers containing all three of the principal elements of plant food, nitrogen, phosphoric acid and potash, are called *complete fertilizers*. The percentages of nitrogen, phosphoric acid, and potash, vary with the crops for which they are intended, nitrogen being higher, for example, in a fertilizer for asparagus or onions, while a fertilizer for the root crops would be lower in nitrogen and higher in potash.

A fertilizer containing 4% nitrogen, 8% phosphoric acid, and 10% potash, is considered the basic fertilizer, but as has been indicated, the percentages vary with the need of the crops to be fertilized.

The rate of application of complete fertilizers is governed by crop requirements and soil conditions. The amount varies from a few hundred pounds to a ton or more per acre for a single crop. The average application per season in intensive gardening is 1500 to 2000 pounds per acre, although the amount applied during the season may be as high as 4000 pounds or more.

**19. Effects of Chemical Fertilizers on the Soil.** Excessive applications of chemical fertilizers tend to cause *soil acidity*. In instances where the supply of humus is not kept up, the soil will become hard and unproductive, as well as acid.

To remedy these conditions, the supply of humus must be maintained and liberal applications of lime made as required. The amount of lime to apply varies with soil conditions; a ton to the acre is usually sufficient for most soils, although as much as three tons per acre are sometimes required to neutralize an acid soil.

**20. Effects of Lime.** Soil acidity is neutralized by

applications of lime, the physical and chemical condition of the soil are improved, causing plant food to be liberated and to become available. Lime, by neutralizing the soil acidity, renders the land unfavorable for the development of the *club foot* of cabbage and other crops belonging to the same family. Most garden crops do best in a soil slightly alkaline and applications of lime bring about this condition. The best results are obtained when the lime is applied in the spring.

**21. Methods of Application.** Fertilizers and lime may be sown broadcast over the land or applied with a fertilizer drill. The drill is far preferable to hand sowing, both for uniformity of application and for convenience. Lime should never be applied with manure, because it liberates the ammonia which will then be lost. The manure should be ploughed under and the ground then harrowed, after which apply the fertilizer or lime, just previous to the time of planting, and harrow it in.

**22. Green Manures.** Green manures and stable manures are the best sources of humus. While the growing of crops for green manuring, or for cover crops is not generally practiced by the market gardeners, humus must often be obtained by ploughing under green crops.

Cover crops, and crops grown for green manures, are divided into two classes, *leguminous* and *non-leguminous*. Crimson clover, red clover, cow peas, and vetch are examples of leguminous crops. Rye is a commonly grown non-leguminous crop.

**23. The Legumes.** The legumes have the ability to take nitrogen from the air and to store it up in *nodules* which grow on their roots. When a leguminous crop is ploughed under, not only is humus added to the soil, but some fertilizer in the form of nitrogen is also added.

The clovers are usually sown in the spring or early summer following an early crop of vegetables. The procedure varies as to when the crop is to be turned under. The crop may be allowed to grow during the season of sowing, and all of it ploughed under the following spring, or a cutting may be had and then the second growth ploughed under. This may be done either in the fall or spring, depending upon whether an early planting is desired. For early results, the crop should be ploughed under in the fall.

Cow peas and Canadian field peas are desirable leguminous crops used for green manuring. Neither of these crops is hardy and they must therefore be ploughed under in the fall. The Canadian field pea is one of the best of the crops grown to add humus to the soil.

**24. Non-Legumes.** Rye is considered more of a catch crop than most of the cover crops grown. It may be sown quite late in the fall, and will make a good growth even in a rather poor soil. Very often poor soils are built up by first growing rye on them, which is turned under and followed by some leguminous crop.

**25. Ploughing Under.** The older or more mature a green crop becomes before ploughing under, the longer it will take for the crop to decompose and for its plant food and humus to become available. The more mature the crop when ploughed under, the more danger there is that the capillarity of the soil may become more or less disturbed, because of the layer of undecayed vegetable matter underlying the ploughed soil. The furrow should be turned on edge as much as possible to avoid this condition. Thorough discing is a great help in restoring the soil to its former capillarity, and also in cutting up the green crop ploughed under.

**26. Effects of Green Manuring.** Green crops are valu-

able and desirable sources of humus, but the rotting of green crops when ploughed under has a tendency to leave the soil somewhat acid. Before attempting to grow all kinds of vegetables in soil on which a green crop has been grown and ploughed under, an application of lime must be made to neutralize the acidity.

**27. Catch Crops.** Green crops are often grown as *catch crops*. After the ground is cleared in the fall, or even before the crop is off the ground, a sowing may be made of crimson clover or rye. Crimson clover is often sowed between the rows of sweet corn when the last cultivation is given. Such catch crops may be grown as sources of humus, or as is often the case, they are grown to hold the soil and to prevent washing. Catch crops being grown only through a limited season seldom grow to much size.



## CHAPTER III

### HOT BEDS

**28. Uses.** Hot beds are used to start plants ahead of season, thereby enabling the grower to mature such crops as tomatoes, cabbage, cauliflower, peppers, and many others earlier than their normal period of maturity. They are also used to grow such crops as radishes, lettuce, and green onions for marketing.

Hot beds are often used for protection, either in the spring or fall. Plants may be planted in a hot bed in the spring and allowed to remain in them until the danger of frost is passed, when the beds are removed; or the hot beds may be used in the fall for maturing crops after the frosts begin.

**29. Location.** The hot beds should be constructed on a well drained piece of ground with a south or southeast exposure. The beds should be protected against cold winds. This may be done by taking advantage of natural wind breaks, such as hedges, board fences, or buildings. A temporary protection may be afforded by erecting frames and putting hot bed mats on them.

**30. Means of Heating.** Hot beds are usually heated by fermenting manure, although steam or hot water are sometimes employed as sources of heat. The coils of pipe are hung on the frames, and pipes incased in tile are buried in the soil. The tile prevents too rapid drying out of the soil.

Hot air is used for heating hot beds by constructing a furnace outside and at the end of the hot bed, and burying

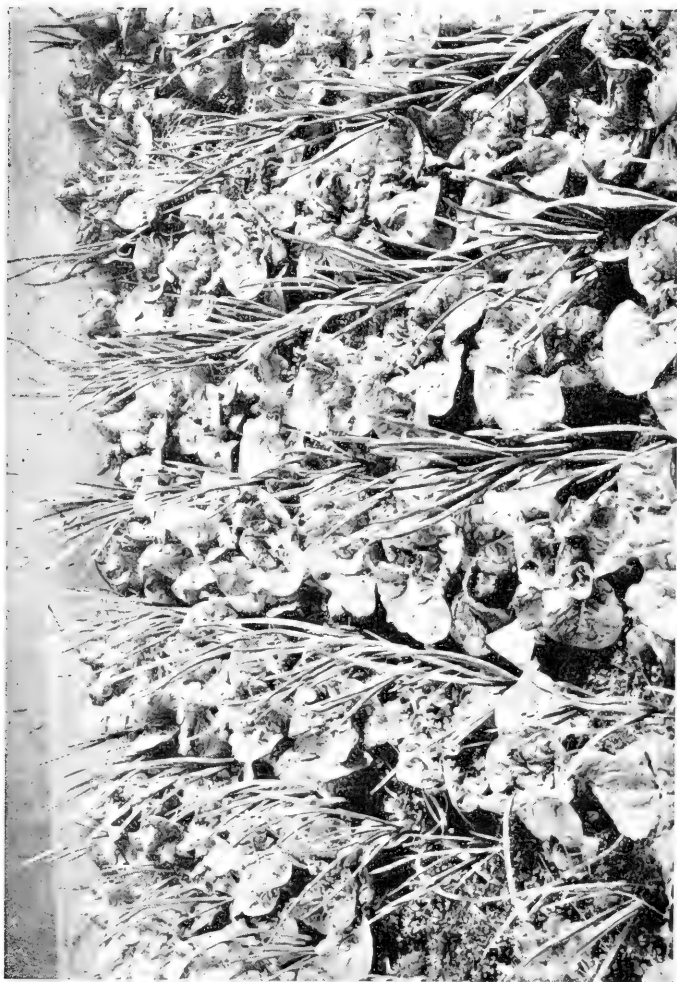

FIG. 7.—Lettuce and Green Onions Grown in a Hot Bed.

the flue in the hot bed. The flue should divide into two lines and unite again at the farther end of the bed. Tile is commonly employed in building the flue, although brick may be used.

**31. Construction.** Manure heated hot beds are constructed by digging a pit fifteen to thirty inches deep and six feet wide and placing over it a frame as long as may be desired. The front of the bed should be six inches lower than the back so that the glass may have the proper slope toward the sun. The common practice is to build the front six inches high and the back of the bed twelve inches high. Fig. 8, which is a cross-section view of a hot bed, shows the general features of construction. The frame should be strongly constructed of durable lumber, such as chestnut or cypress planking, and 2×4 inch posts. Cross bars should be placed from the front to the back of the bed at regular intervals to stiffen the frame.

The frame of the hot bed is constructed to support the sash, which is commonly 3×6 feet, and glazed with 10×12 inch glass. Smaller glass is sometimes used, but three sections of 10×12 inch glass is preferred by most growers. Sash is often made and used in sizes larger than 3x6 feet, but larger sash is much heavier and more awkward to handle, also a bed over six feet wide cannot be worked advantageously. The sash should be made of cypress or cedar to assure durability.

The depth of the pit is determined by such factors as the time of year, whether the weather is severe or mild, and the kind of crop to be grown. Such crops as radishes or lettuce do not require so much heat as do tomatoes or peppers.

**32. Preparation of the Manure.** Horse or mule manure may be used as a source of heat. The manure should be

freshly gathered, or else should be manure that has not been heated. Place the manure in a pile about six feet wide and four feet deep and as long as may be necessary. The manure should be prepared under cover of a shed for best results. As the pile is constructed, the material should be shaken out and well firmed with the back of the fork or by lightly tramping.

The pile should be examined often, and as soon as a good heat is generated, it should be turned, taking care

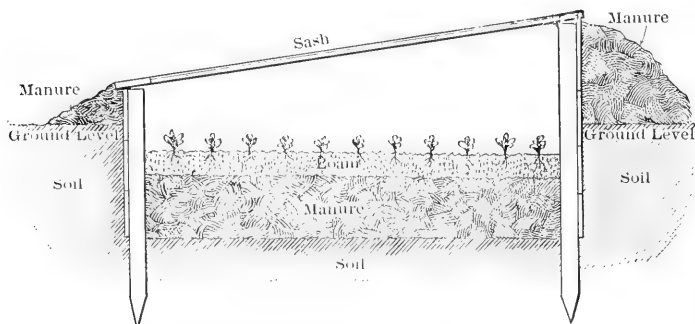

FIG. 8.—Cross-section of a Hot Bed.

that the outside of the pile is placed in the centre of the new pile. Examine the pile carefully and in two or three days the fermentation will again have become well started heating the manure thoroughly. The manure is then ready to put into the pit.

The manure is placed in the pit, a layer at a time, four to six inches deep, and tramped well, especially in the corners and along the sides. After the pit has been filled to the required depth, two to six inches of good loam is placed on the manure. When the hot beds are used for the growing of plants in flats or pots, two inches of soil is

sufficient to keep the air sweet, and to absorb the moisture from the manure. When crops are to be grown in the soil of the hot bed, the soil should be at least six inches deep.

After the manure has been placed in the pit and covered with loam, the hot bed thermometers should be thrust into the manure, and the sash, shutters and mats should be placed over the hot bed. As soon as the manure has again become hot and the soil is warmed through, the bed is ready for the introduction of plants in flats, or for the planting of crops in the soil.

**33. Care of the Hot Bed.** Careful attention to the details of watering and ventilation are necessary for the success in growing plants in hot beds. The water should be applied evenly and at a time when the temperature is rising. Watch the beds at the sides and corners that they do not dry out too rapidly. The hot beds are ventilated by raising the sash, either at intervals along the bed, or all of them, as the conditions may demand. Small blocks of wood are handy for placing under the sash for ventilating. Avoid drafts as much as possible at all times, particularly with such crops as tomatoes, peppers or any other of the more tender crops.

In the early spring, when the weather is yet quite severe at times, the hot beds must be banked with hot manure at the time that the pit is filled with manure for heating the bed. The manure should be banked to the full height of the frames and tramped firmly. Anything that will exclude the cold may be used for covering the frames at night and during severe weather. Mats of various kinds may be purchased, or straw mats may be made at home. Old blankets are sometimes used, also wooden shutters. The shutters are made the same size as the sash, 3x6 feet, and of light lumber.

## CHAPTER IV

### SEEDS AND SEED SOWING. TRANSPLANTING

**34. Quality of the Seed.** The importance of planting good seed cannot be overestimated, because upon the selection of the seed may depend the success or failure of the crop. Several factors determine the quality of the seed; the most important are *viability* and *truth to name and type*. To have a high percentage of germination the seed must be viable, i.e., must have the ability to germinate under average conditions and grow into seedlings. The seed must be true to name, that is, it should produce plants of the variety for which it is purchased. It must be true to type, or strain. Most varieties of vegetables and fruits have a number of types; it is undesirable that a planting of any crop should be a mixture of several types.

The average of good seed is reasonably free from weed seeds and dirt, but the grower should be sure that his seed is clean before planting it.

The growing of seeds at home is quite extensively practiced and with good results if the grower has a definite, fixed idea as to the type of plant which he wishes to propagate. When selecting fruits for their seeds, the grower should select the plant for its good qualities rather than select the biggest and finest fruits regardless of the plant upon which they have been grown. If the plant is not vigorous and does not possess desirable qualities, it is probable that the seed saved, even though the fruits be

desirable, will not produce fruits of the grade desired. The average grower will usually do better to buy his seed from a reliable seedsman rather than to attempt to grow his own seed.

The seeds of most vegetables are viable and will produce good plants and crops if they are more than one year old when planted. The best practice is to plant fresh seeds because the quality of the seed is determined as much by the conditions under which they have been stored as upon the conditions under which they have been grown. Seeds should be stored in tight bags in a cool dry place.

**35. Germination.** Each seed contains a minute plant ready to start into growth as soon as sufficient heat and moisture are supplied. Figs. 9(a), 9(b), 9(c) and 9(d) show successive stages in the growth of a corn seedling. The minute plant in the kernel absorbs moisture and increases in size, first sending out a root and later the stem. Later, other roots appear and the stem turns upward toward the light while the tap root pushes its way downward into the soil. Until the roots are grown, the kernel furnishes food to the plant.

Seeds may be germinated between layers of moist, warm flannel, or in small germination dishes, and will make sufficient growth under these conditions for the grower to test his seeds and determine the percentage of viable seeds. All seeds which will germinate, that is start into some growth, will not grow into a good plant. It is only the seeds producing a strong root and sprout that will grow into good plants.

Every grower of vegetables should test his seeds before planting any of them in the ground. A simple and convenient method is to take a piece of clean white flannel, dip it in warm water and wring the water out until it no longer

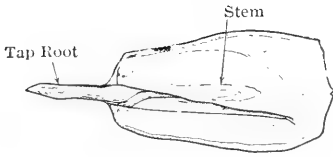

FIG. 9 (a).—The Germination of Corn. The tap root is appearing and the embryo plant is much increased in size.

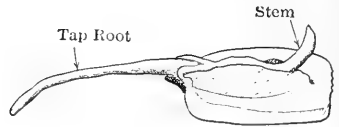

FIG. 9 (b).—The Germination of Corn. Tap root longer and stem appearing. Note how the stem is growing upward toward the light and the root downward into the soil.

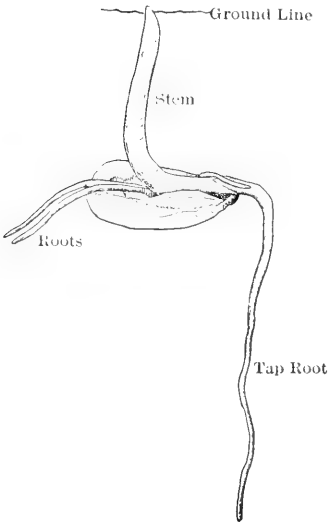

FIG. 9 (c).—The Germination of Corn. Stem breaking through the Soil.

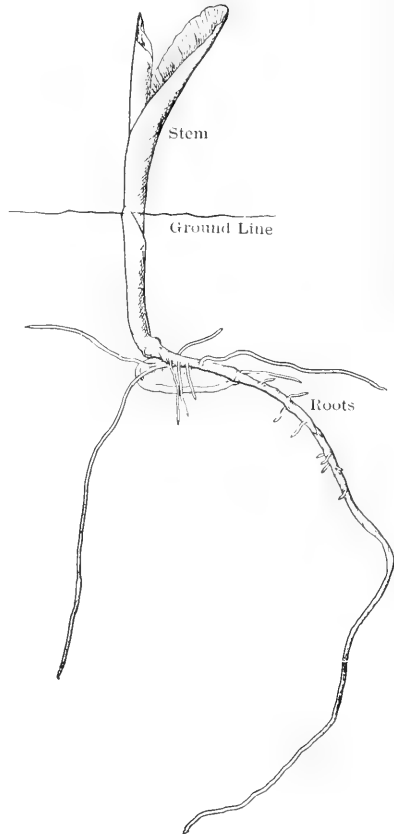

FIG. 9 (d).—The Corn Seedling.



drips from the flannel. Two warm, eight inch plates will then be needed to contain the flannel. Lay the flannel in one plate and on one end of it count out a number of seeds. It is best to use the seeds in lots of from ten to one hundred; one hundred being the best number to use as a fairer test can be had from this number of seeds than from any smaller number. After the seeds have been counted and laid on one end of the flannel, fold the other end of the flannel over the seeds so that they are all covered. The second plate should then be placed over the first plate containing the flannel and seeds, with the bottom of the plate upwards, and the whole set aside in a place where the temperature can be kept at about 70°. The seeds should be examined every day that the flannel may be kept moist by additions of water, and all germinated seeds counted and thrown out. The number of seeds remaining after all the germinated seeds have been thrown out will determine the percentage of germination for the lot tested. Thus, if we have one hundred seeds and twenty remain after the test, we know that eighty per cent of the seeds are viable and can reasonably be depended upon to produce plants.

**36. The Seed Bed.** The seed bed must be carefully and thoroughly prepared; lumps and coarse material must be raked out, leaving the surface in a fine, smooth condition. The seed bed should have a depth of at least four to six inches of good loam and should be thoroughly pulverized clear to the bottom. The lighter soils furnish the best conditions for making the seed bed and are more easily gotten into proper condition than are the heavier soils.

After having thoroughly prepared the seed bed, the conditions necessary for the germination of the planted seeds are principally *heat* and *moisture*. All soil contains some *air*, at least a sufficient amount will ordinarily surround a seed

for its use while germinating and growing into a seedling. The conditions which have to be supplied then are the heat and the moisture. If the seeds are to be planted in a hot bed, the ground must be warmed by the use of glass and the manure under the bed; if the seeds are to be planted in the open ground we must depend upon the weather conditions for the right temperature of the soil. The seeds of the cooler loving plants such as cabbage, or turnip, may be planted in cooler soils than such seed as tomato, egg plant or cucumber. Such seeds as lettuce, spinach, cabbage, beet and radishes may be sown earlier and under cooler conditions than may seeds of tomato, corn, egg plant, melons and other warmth loving plants.

The time for seed sowing depends upon such factors as condition of the soil, liability for frost and the season. For such plants as tomatoes, peppers, egg plant, lettuce, cabbage and other transplanted crops, the time for sowing the seed under glass is determined largely by the season in which it is desired to harvest the crops.

**37. Planting.** In the home garden the seeds are usually planted by hand by dropping them in the hill or furrow previously prepared. That the rows may be straight and a uniform distance apart, the ground should be measured and staked and a line used in marking out the rows. The line should be stretched tightly and the corner of a hoe or the back of a rake used to follow the line and make the proposed furrow. The seeds should be dropped at uniform intervals; seed held between the thumb and finger may be dropped evenly with a little practice. For the larger garden, a seed drill is indispensable for economical planting. The depth of planting is then easily regulated.

After planting, the soil should be firmed by pressing it down with the back of a hoe or rake. This is done to restore

the capillarity of the soil which has been destroyed by opening the furrow or hill. The seed drill does this by the pressure of the trail wheel which follows over the planted row after the seed is covered by the planter wings.

For the best and quickest results the seed should be planted only in freshly prepared ground. In such ground the conditions of heat and moisture are at their best and the seed is placed in surroundings most favorable for quick germination and the growth of the seedling.

**38. Transplanting.** To obtain early fruits of such plants as tomatoes, cabbage, cauliflower, egg plant and peppers, it is necessary to plant the seeds early, in a protected location, or in a green-house or hot bed, from which the seedlings are transplanted one or more times.

Some of the benefits of transplanting are early maturity, the economical use of the ground by growing seedlings for transplanting to the field as soon or even before a crop is taken off, the increase in productiveness that results from transplanting. A plant that has been transplanted develops a better root system than one that is not transplanted.

Plants to be transplanted should be allowed to dry out for at least a day previous to transplanting and watered just before transplanting. This procedure tends to fill the plants with water just before disturbing them, it also aids in retaining a ball of earth around the roots. The plants should be lifted carefully that the system of roots be disturbed and broken as little as possible. The plants will start easier and more quickly if a little water is poured around them when transplanted, or if they can be irrigated after being set.

Before transplanting begins, the field should be carefully marked that the rows may be straight and properly spaced.

The time to transplant is determined by conditions of the plants to be transplanted, the weather conditions, conditions

of the soil, whether dry enough, moist enough, warm enough, or properly prepared. If possible, it is best to choose a cool or cloudy day for transplanting, or to trans-

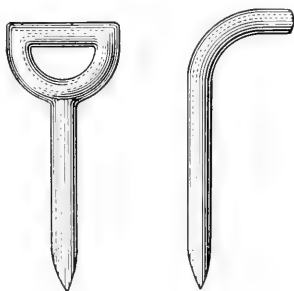

FIG. 10.—Dibbers for Transplanting.

plant just before a rain. When these conditions are not to be had, do the transplanting late in the day, rather than in the morning.

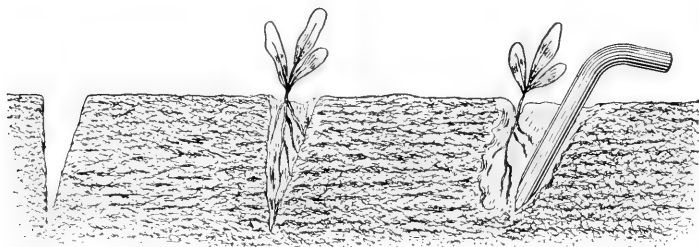

FIG. 11.—Proper Method of Using a Dibber in Transplanting. Note how the soil is pressed firmly around the roots of the seedling.

When transplanting, set the plants just a little deeper than they were set previously.

Plants are generally transplanted by hand, a dibber or

trowel, Fig. 10, being used to make the hole. After the seedling is placed, the soil should be pressed firmly around the roots with the fingers, or with the dibber or trowel handle as in Fig. 11.

When the gardening operations are small, the transplanted plants can easily be shaded for a few days after being set in the field. Shingles, paper bags, small boxes, or anything that will cast a shadow may be used for shading.

## CHAPTER V

### IRRIGATION

**39. Moisture Requirements of Plants.** Water plays a most important part in all stages of plant growth. Moisture is necessary for seed germination and is no less necessary to the seedling and plant. The soil may be properly prepared and there may be an abundance of properly balanced fertilizer, but unless sufficient moisture is present in the soil the plant can make but little growth or get but little benefit from the fertilizer supplied for it.

Water is a solvent of plant foods. It also acts as a carrier of plant food in solution, and holds plant foods in solution in the soil. Moisture is necessary for the action of friendly bacteria, and by carrying solvent acids to the plant food present in the soil, it makes the plant food available to the plant.

Vegetables are composed very largely of water; in some cases they are over 90% water. The plant juice, or *sap*, is composed very largely of water, it thereby becoming the principal agent in the carrying of plant food from the soil to the various parts of the plant. Enormous quantities of water are transpired during the life of the plant, several hundred pounds of water being necessary for the making of a pound of dry matter.

Irrigation may be looked upon as insurance against drought. With a plentiful supply of water the gardener is independent of the uncertainties of rainfall. Sufficient

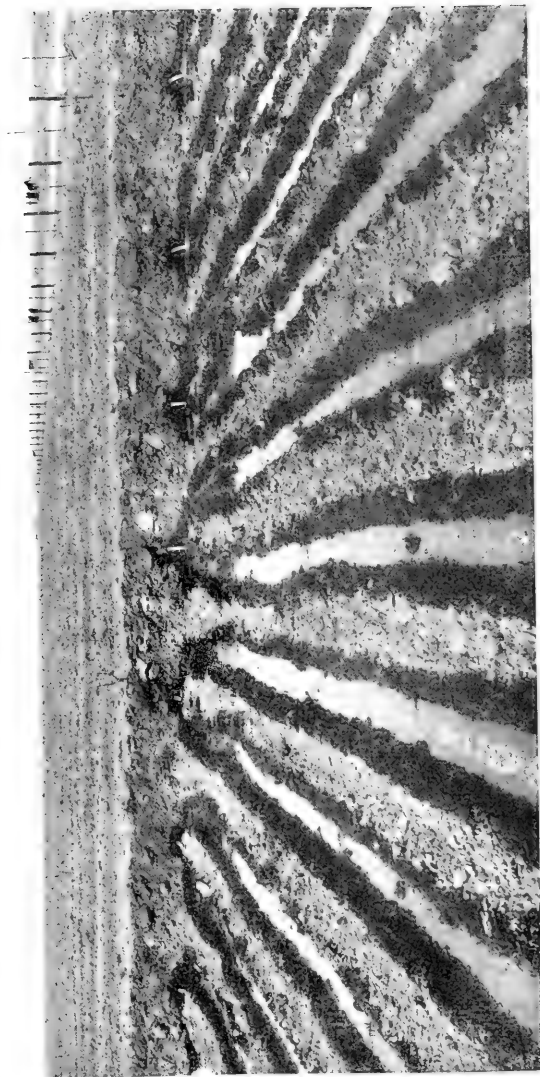

FIG. 12.—Furrow Irrigation.

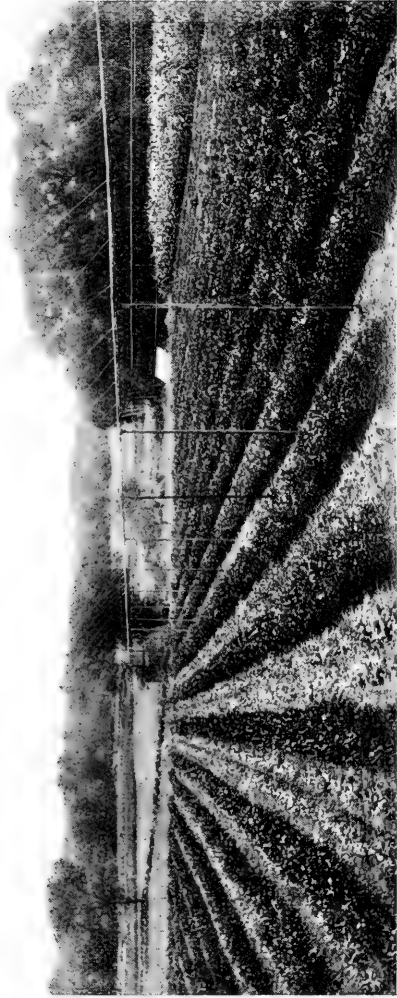

FIG. 13.—Skinner Overhead Sprinkler System of Irrigation.



moisture insures larger yields, good quality and proper maturity of the crop. It may mean the difference between a full crop and practically no crop for the season.

**40. Methods of Irrigation.** There are several methods of applying water; the kind of gardening usually determines the manner of supplying water artificially. Thus, water may be applied with a hose, in the furrow, or with an overhead sprinkler system. When the garden is extensive, the *hose method* is neither very practicable nor satisfactory. If the gardening be intensive and the rows are close together, the *furrow method* is not practicable owing to the small amount of room in which to handle the water between the growing plants. The *overhead sprinkler system* is by far the best and most natural method of supplying water. The water is applied gently, and crops growing in rows close together can be irrigated successfully in an extensive manner with this method. The Skinner system, Fig. 13, is the best overhead system to be had. It consists of overhead pipes that are perforated and have small nozzles in the perforations. The pipes may be turned completely around, thus distributing the water evenly in all directions from the pipe line.

The amount of water to be applied at one time depends upon the conditions of the soil, the weather, and the crop. About an inch of water is the limit that should be applied at one time.

## CHAPTER VI

### VEGETABLE GARDENS

**41. The Home Garden.** The home vegetable garden should be given far greater care and consideration than is generally accorded it. As a factor tending to lower the increasing cost of living, the home garden can be of use practically the year round. No area on the farm is as profitable as the home garden. Not only will it furnish vegetables for the home table but it often will furnish a sufficient supply for sale to the local market or to the neighbors.

The work done in the home vegetable garden is usually done at odd times and for this reason the garden should be located as close to the house as the conditions may permit. It should also be near the house so that the supply of fresh vegetables may easily be had at short notice. The garden should be carefully planned that the area planted may give the greatest returns for the money expended and the work done. The perennials such as rhubarb, asparagus, horse radish, strawberries and such bush fruits as blackberries and raspberries should be planted at one end of the garden in order that they may not interfere with the cultivation and harvesting of the general garden crops. Fig. 14 shows a good arrangement.

The home vegetable garden is not complete without a small hot bed in which to grow such crops as radishes and lettuce, out of season, and for starting such plants as lettuce, cabbage and tomato plants for transplanting.

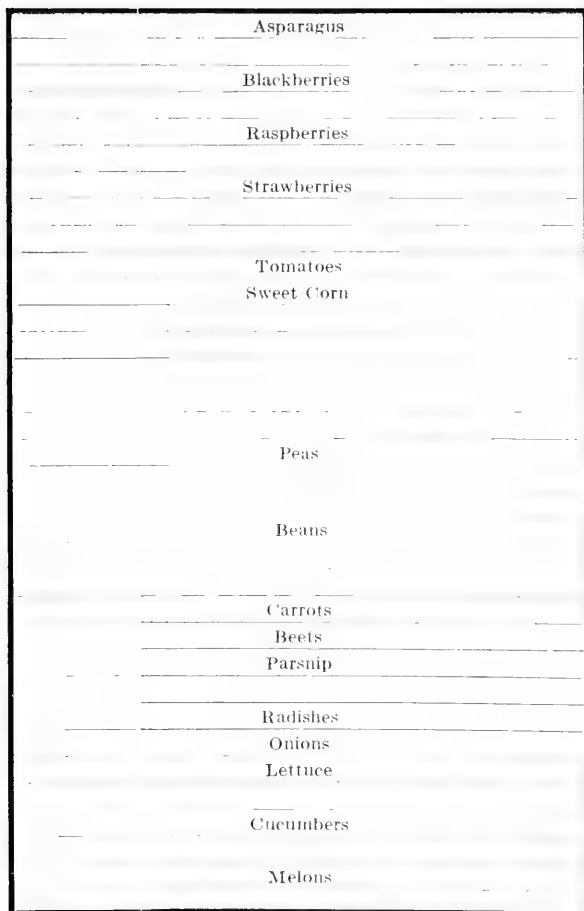

FIG. 14.—Plan of Home Vegetable Garden.

The home garden should be thoroughly prepared and well fertilized for the best results. A heavy dressing of manure is always essential and will often be the only fertilizer necessary, but a dressing of chemical fertilizer will give returns far greater than the investment necessary for its use. Frequent and thorough cultivation should be given and, as conditions may require it, some form of irrigation should be practiced. Frequent cultivation largely eliminates the necessity of irrigation as the cultivation maintains a dust mulch which acts as a conserver of the moisture already in the soil.

Such crops as carrots, beets, turnips and parsnips are easily stored either in the ground or in a cool cellar. When the house cellar contains a furnace, one end of the cellar may often be partitioned off so that the air in it is constantly cool and fresh. Root crops stored in cellars should be buried in moist sand and kept as cool as possible without freezing. When there is no cellar available for storing the root crops, pits may be used to advantage. The location of the pit should be on well-drained soil. A sandy soil is best for this purpose as it affords good drainage. The pit should be about three feet deep and the roots should be covered to a depth of from six to eighteen inches, depending upon the locality and the season. Ventilation should be provided by placing short lengths of tile in the pit, slanted away from the prevailing winds. The tile should extend at least two inches above the surface of the pit. The soil thrown over the pit should have sufficient crown to cause it to shed water easily. Cabbage may be stored in a pit or in a cool cellar when placed on shelves or in small well-ventilated bins.

**42. School Gardens.** As the excellent custom of planting and caring for vegetable and flower gardens as a part of

school recreation and training is increasing, it is hoped that this little manual may be found of value as a concise and practical guide in such work. For this reason, brief suggestions for the planning of the school garden are here given.

When the area available for the school garden is of sufficient size, the ground should be prepared by the use of teams. A good dressing of rotted manure should be ploughed under and this followed by thorough discing. A dressing of a high grade, complete chemical fertilizer is desirable. After discing the ground, the surface should be gotten into condition with the smoothing harrow. If the use of teams is not possible, the ground may be spaded and raked by hand.

*Plots.* The individual plots should be laid off by the use of stakes and a cord to surround each plot and the rows should be laid off to run across the whole row of plots, that the row spacing may be uniform. The plots should be numbered. The size of the plots is often determined by the area available for the class. The size of the plots may be determined by the age or previous experience of the students. The plots vary from six by six feet for the smaller children up to as large as one hundred feet long and six to eight feet wide for the older, or more experienced students. Six feet wide is the most desirable width for the school garden; plots wider than this are hard to work without walking on them. The center of a six foot plot can easily be reached from each side. A path eighteen to twenty-four inches wide should be left between the plots. This gives sufficient space in which to work and provides space into which trash and weeds may be dumped, later to be hauled away.

It is desirable that the plots be laid out so that the rows may run north and south rather than east and west. A north and south row assures for each row an equal amount



FIG. 15.—School Garden. Onions and transplanted beets in the foreground.

of sunlight. This is quite important in growing tall crops together with low growing crops.

The planting distance will largely be determined by the crops grown. Such crops as carrots, beets, radishes, onions and lettuce may be grown in rows sixteen inches apart. When carrots, beets, lettuce or other small growing crop are grown, the radishes or onion sets may be used as fillers, being set in the center of the sixteen inch rows. This leaves the rows but eight inches apart. Such crops as beans, peas, peppers, egg plants and similar size crops should be planted in rows from eighteen to twenty-four inches apart. Radishes lettuce and onion sets are fine fillers, or *companion crops* to be used with such crops.

The vegetables grown should be of the common kinds with which most students are more or less familiar. If desired, flowers may also be grown, one end of each plot being devoted to them.

*Plan.* The following plan is suggested for a plot six feet wide and thirty feet long:

Beginning at one end of the plot lay off twelve rows sixteen inches apart, and seven rows twenty-four inches apart. In the sixteen inch rows, plant four rows each of lettuce, beets and carrots and interplant six rows with radishes and six rows with onions or onion sets. In the twenty-four inch rows plant one row each of peas, beans, cabbage, cauliflower, peppers, egg plant and tomatoes. It is expected that these larger growing crops will be grown from transplanted plants rather than from seed. Between the twenty-four inch rows there may be planted transplanted beet or lettuce plants. The space should again be divided by planting radish seed in the center of the twelve inch rows. Such a plan as outlined will give the student a good working knowledge in the handling of seeds, and plants for trans-

planting, and will afford an example of intensive gardening and in the use of companion crops.

*Tools.* The tool equipment should consist of a sufficient number of small garden hoes, hand weeders, trowels and dibbles so that each student may have proper tools for each operation. The garden hoes should be light, yet strong, and not too wide as they must be used in rows as close as six inches. A number of rakes must be available for use in preparing the plots for planting. It is highly desirable that a number of wheel hoes and seed drills be available for planting the gardens, at least in part, and for cultivating. There are a number of desirable combination seed drills and wheel hoes on the market, the most desirable of which are those in which the seed drill or the wheel-hoe attachment may be used entirely independent of each other. It is not expected that all of the planting will be done by the use of the seed drills but the student should have sufficient use of these tools to become familiar with them.



## CHAPTER VII

### STORING AND PACKING

**43. Storage Cellars and Pits.** That the greatest returns from the vegetable garden may be had, a considerable portion of many of the crops must be stored and held for sale during the winter months. Such crops as beets, carrots, turnips, celery, cabbage and potatoes are easily held if properly stored.

The *root cellar* is the most common storage. This may be a cellar under a barn or house, or it may be a pit substantially walled and roofed to equip it for permanent use. The cellar or pit should be frost proof and so located that perfect drainage is had. Provision must also be made for ventilation. During the early fall and in the spring, the temperature of the storage is dependent upon the ventilation, the doors and ventilators being opened at night and closed early in the morning that the cool air of the night may be held during the day.

**44. Storing Root Crops.** The root crops to be stored must be handled carefully to avoid unnecessary bruising. The tops should not be cut too close to the root; about one inch from the root is the right length to cut the tops. Do not expose the roots to the air longer than is necessary before moving them to the storage. Clean, moist sand must be provided for covering and burying the roots. The roots should be cool when placed in the storage. Root crops can be held in good condition in open bins if the air

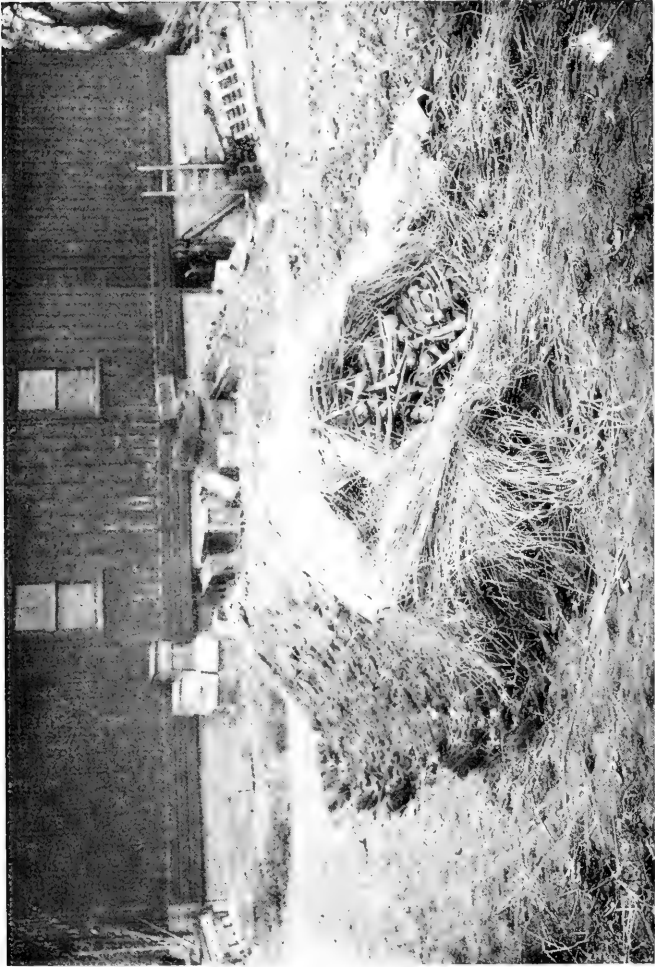

FIG. 16.—Parsnips Stored in a Temporary Pit. Note the method of covering.

surrounding them can be kept cool and moist; however, there is certain to be considerable loss when root crops are held uncovered because the top and outer layers will dry out and sprout. As the roots are brought in from the field, they should be covered to a depth of about six inches with the moist sand. Keep the air in the cellar as cool as possible without freezing.

**45. Celery.** Celery is usually stored in temporary pits and houses as in Figs. 17 and 18. A satisfactory celery pit may be made by digging a trench about six feet long, thirty inches deep and as long as may be necessary for the accommodation of the crop. The celery is lifted with most of the roots intact and placed in the pit as closely as possible, the pit is then covered with boards, provision being made for ventilation. As the weather becomes more severe, the covering is made frost proof with mats, blankets or strawy manure and soil. When celery is stored in large amounts, a good storage can be made by constructing a temporary, even span, house out of boards used in blanching the early celery. The roof may be covered with any available trash from the fields such as tomato tops, or strawy manure, and earth thrown over all. A covering of earth should be added to as the season advances and the cold becomes more severe. A narrow walk is left through the center of the storage for the convenience of the workmen in getting out the celery; this is generally provided by staking up planks to hold the celery in place.

Cellars provide excellent storage for celery, the celery being held in place with planking. The celery roots may be partly buried, or set on top of the ground as is done when the plants are placed in a pit. The plants should be placed close together.

**46. Onions and Cabbage.** Onions are usually stored in



FIG. 17.—Temporary Storage for Celery.



FIG. 18.—Celery Storage Covered and Partly Banked.

well insulated houses constructed for the purpose. The best practice is to use crates holding about one bushel each,

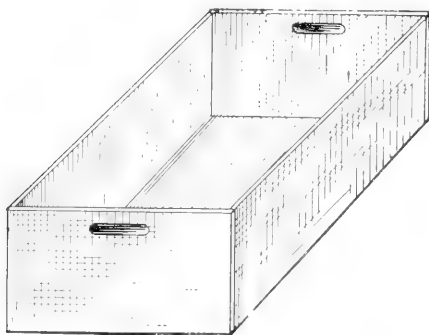

FIG. 19. Bushel Box.

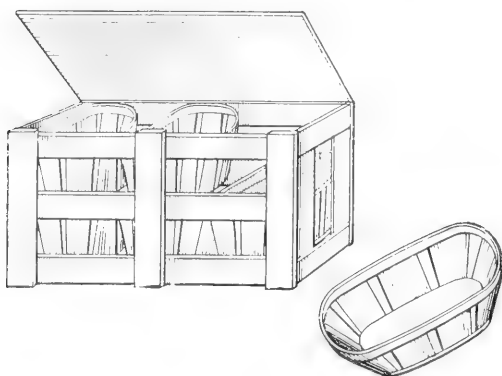

FIG. 20.—Six-basket Crate; Six-quart Baskets.

although shallow, well ventilated bins are sometimes used. Ample ventilation must be provided and the temperature must be kept as near  $33^{\circ}$  as possible. Onions will not stand

freezing and thawing, but if kept frozen they will be of good quality when thawed, if used at once.

Cabbage should be stored in cool, well ventilated cellars. Narrow bins may be used for holding the cabbage. The temperature should be kept low and a constant supply of fresh air should be provided. Cabbage may be stored in pits, all of the outer leaves being left on the heads. The

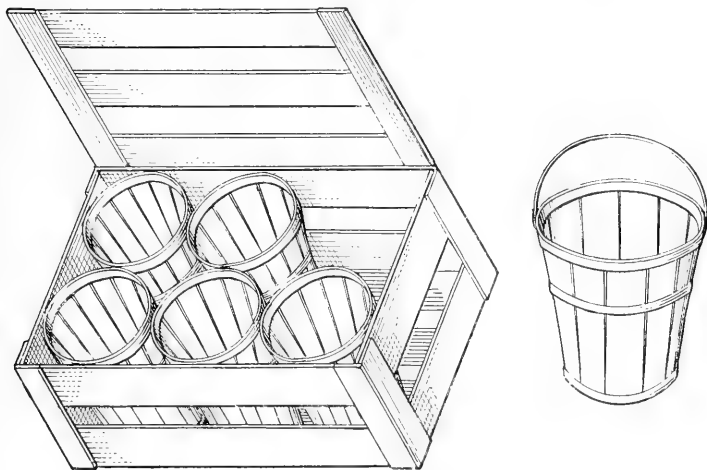

FIG. 21.—Six-basket Crate; Four-quart Baskets.

heads should first be covered with straw and then earth should be placed over them. The depth of the covering must be increased as the weather becomes more severe.

When removing vegetables from pits, or other temporary storage, care must be exercised that the remainder of the vegetables are not chilled or frozen.

**47. Packing.** The package most generally used for local marketing is the bushel box, Fig. 19. It is a durable

package and lends itself to the safe carrying and delivery to market of a great variety of crops. The bushel box is easy to handle and to load on a wagon, or truck, or to handle in shipping by express or freight.

Crates are used for such vegetables as asparagus and celery when packed for long shipment. The size of the crate varies with the demands of the market and the locality

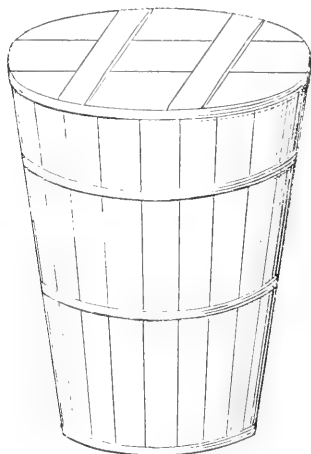

FIG. 22. —Barrel Hamper.

served. Cabbages and cauliflower also are often shipped in crates, although barrels are quite generally employed in shipping these two crops.

Bushel baskets of various designs are used for shipping such crops as peas, string beans and spinach. The basket is usually of the "peach basket" type and has a light wooden cover, easily attached.

There are a number of special packages on the market





FIG. 23—Onion Storage where Crates are Used.

which are often of much value for use in a local market. Tomatoes are often packed in small baskets which are crated for shipment, as in Fig. 20. The crate usually holds six baskets although some crates are large enough to hold twelve baskets in two tiers of six baskets each. The cost of such a crate, with the baskets, runs from twenty-five cents to thirty cents each. The cost is too high for general use, and such a package can be used profitably only when crops are grown and shipped out of season and the returns are proportionately higher than normal.

Tomatoes sold in small baskets, holding about ten pounds each, of which there are six baskets to the crate, as in Fig. 21, should be wrapped in thin paper wrappers for the best result. The wrapper may be used to advertise the grower and to establish a brand. Tomatoes which are wrapped will carry better and open up in better condition than will tomatoes which are not wrapped. Only hot house grown fruit will usually justify the use of expensive packages and the wrapping of each fruit.

## CHAPTER VIII

### CROPS

#### I. ASPARAGUS

**Propagation.** Asparagus beds, or plantations, are usually established by planting one year old plants. Two year old plants which cost more are often planted, but the one year crowns give the best results and should be used in starting an asparagus plantation.

The seed should be the best obtainable and is best sown with a seed drill in rows not less than sixteen inches apart for hand cultivation, nor less than thirty inches apart for horse cultivation. The ground selected for a seed bed should be a rich mellow loam, free from stones or rubbish. The seed should not be covered deeper than one and one-half inches. Do not sow the seed too thickly. The plants for best development should stand not less than two inches apart in the row, three or four inches apart would be better.

The plants should be lifted in the fall and stored in a root cellar covered with moist sand.

**Planting.** The field selected for an asparagus bed should be a rich deep loam, thoroughly cultivated, as free as possible from stones or rubbish of any kind. Previous to planting, the field should be heavily fertilized with well rotted manure. This should be supplemented by a liberal application of high grade, complete fertilizer. Nitrate of soda should be applied at intervals during the growing season. Spring planting is generally practiced.

The crowns should be set in furrows, six to twelve inches deep, depending upon the depth of the top soil. It is not advisable ever to make furrows so deep that the roots will be in or very near the sub-soil. Eight to ten inches is the average depth of planting. The reason for deep planting is that, as the crowns renew themselves each year, they come nearer the surface. Deep planting also places the crown deep enough so that the plantation can be cultivated by a disc harrow without injury to the crowns. Deep planting thus insures a longer life for the plantation than shallow planting.

After the furrows are made, make sure that there is a layer of good soil in the bottom of the furrow on which to place the crowns. Spread the fleshy roots out so that their position will be as nearly as possible that in which they grew in the seed bed. Cover the crowns to a depth of two or three inches, firming the soil well over the roots. The crowns should not be covered any deeper until the shoots come through the ground, when the furrows may be gradually filled in by cultivation. The furrows can usually be leveled by the cultivation practiced the first season, in any event the ground should be leveled by fall.

**Distance to Plant.** In good rich soil the rows may be four feet apart and the plants set two to three feet apart in the row. Planting distances vary in different localities and states, but the average distance is two and one-half to four feet.

**Cultivation.** As early as the ground can be worked, thoroughly cultivate the field with a disc harrow. The soil should be kept well cultivated through the growing season as long as horse-drawn tools can be used without much injury to the tops. Hand hoeing may be necessary at times but it is not generally practiced on large plantations.

**Ridging.** There are two kinds of asparagus marketed, *green* and *blanched* grass. Blanched grass is produced by cutting the shoots as soon as the tips show above ground; green grass is produced by cutting the shoots as soon as they have grown to the required length above ground. The shoots may be cut at the surface of the ground or just below the surface. Whether blanched grass or green grass, is desired, the practice is to ridge the ground over the rows. The ridges should be higher for producing blanched grass than for producing green grass. The purpose of the ridge is primarily to gain a greater length of stalk of blanched grass.

**Harvesting.** A light cutting of asparagus may be had the second year, if plenty of fertilizer is applied to the plantation. The third year the cutting may continue from three to four weeks. As the plantation becomes older, the cutting season is extended until it may continue from eight to ten weeks.

The shoots are gathered by cutting them off with a sharp knife. When blanched grass is desired, the knife is passed down the stalk until the required length is attained, when the shoot is cut off. The stalks should be cut long enough to make bunches six to ten inches long. The number of stalks to the bunch varies, but the bunches should be four and one-half inches in diameter, and weigh two and one-half to three pounds.

**Yield.** The yield per acre varies; 1500 to 2000 bunches per acre being considered excellent yields. The returns often run as high as \$500.00 per acre, but the average is \$200.00 to \$250.00 per acre, for plantations in their prime.

**Fertilizers.** During the cutting season, nitrate of soda should be sown along the rows, or broadcasted, in three or four applications. After the cutting season is over,

apply 1000 to 2000 pounds per acre of a high grade fertilizer. In the fall broadcast rotted manure at the rate of at least 20 cords per acre and let it lay on the ground over the winter. The manure should be disced in in the spring.

## II. BEANS

**Soils.** Beans do well on almost any kind of soil if it contains a reasonable quantity of humus. Light, well-drained soils, however, are especially desirable. Bush beans do best in sandy soils. Lima beans are the most difficult to grow as they require a long season to reach maturity and are very susceptible to adverse conditions, such as wet ground at the time of planting or continued cold weather.

**Planting.** Beans should not be planted until danger of frost is passed and the ground is well warmed, although the bush varieties are more resistant to cold than are the pole beans. Beans may be planted in hills or drills as desired. The distance between rows of bush beans, where horse cultivation is practiced, is thirty inches to thirty-six inches. When hand cultivation is practiced, it is best not to plant in rows closer than eighteen or twenty inches. The seed should be of the best quality. Pole beans should be planted in hills three or four feet apart.

Bush beans are usually planted in a drill, the depth of planting varying with the kind of soil and the season of planting, from one inch in heavy soils to three inches in lighter soils.

**Use of Supports.** Wire trellises may be used, or poles seven feet or more in height, for the support of the pole beans. The bark should be left on the poles that the beans may have a rough surface on which to cling.

**Cultivation.** Frequent and thorough cultivation should

be practiced. It should be borne in mind, however, that the bean is a shallow-rooted plant, and that the cultivation must be carefully done to avoid breaking the roots.

**Harvesting.** Snap or shell beans must be gathered by hand. Half-bushel baskets are convenient for this purpose. Field beans may be pulled by hand or harvested by machines that cut the plants off close to the ground and leave them in windrows. After cutting, the beans are allowed to cure until in the proper condition to run through a threshing machine.

Snap or shell beans are marketed in baskets or boxes holding a bushel each. Dry or field beans are generally marketed in sacks. Previous to sacking, the beans are run through machines that remove the dirt and rubbish.

**Varieties.** There are many varieties of beans and the grower, in selecting his varieties, will do best to choose such varieties as have been proven adapted to the conditions under which he intends to grow them.

**Fertilizers.** Nitrogenous fertilizers are not required to any extent for beans. A complete fertilizer containing 2% or 3% of nitrogen, 8% potash and 10% of phosphoric acid, is well adapted to fertilizing beans. This should be used at the rate of 500 to 1500 pounds per acre.

To maintain the supply of humus, cover crops may be grown and ploughed under, or stable manure ploughed in at the rate of 10 to 15 cords per acre.

### III. BEETS

**Soil.** Beets do best in light soils; sandy loams being particularly desirable. Such soils produce a crop early, with roots smooth and free from fibrous roots. Heavy soils tend to irregular shaped roots and to the production



FIG. 24.—A Good Crop of Beets.



of many fibrous roots. If beets are being grown for a local market, not too discriminating, they may be a profitable crop when grown in any good soil.

**Planting.** Beets are a cold-loving vegetable and may, therefore, be planted in the spring as soon as the ground can be gotten into good condition. The seed should be the best quality obtainable and should be sown in drills, not too thickly. The rows should be fourteen to sixteen inches apart. The distance between plants in the row will depend upon the size of root desired. It is a good plan to sow the seed rather thickly, thin them when six to eight inches high, and sell the thinnings for greens. The next pulling would be for early bunch beets and the final harvest would be of the roots near maturity or when fully grown.

**Transplanting.** Beets transplant easily and to good advantage in sandy loams. The plants should be grown from four to six weeks in a hot bed or greenhouse before transplanting. Handle the seedling carefully, the more careful the handling, the fewer fibrous roots will be found. The plants should be well hardened before moving them to the field. If well hardened, they will stand freezing without damage.

**Marketing.** Early beets are always sold in bunches, the number in a bunch varies from four to ten, depending upon the season and the size of the roots. More mature beets are sold by the bushel box. The tops are cut off at least an inch from the root.

**Fertilizers.** Early beets should grow very quickly. The beets for storage need not be grown so rapidly, but should maintain a steady growth. Nitrogenous fertilizers are necessary for earliness, but a more balanced fertilizer is best for the later crop. The ground should have a heavy dressing of stable manure at the rate of at least 20 cords to



FIG. 25.—Early Jersey Wakefield Cabbage.

the acre. This should be supplemented by the application of a high grade complete fertilizer containing 4% nitrogen, 8% phosphorus, and 10% potash, and used at the rate of a ton to the acre.

**Storage.** Beets may be stored in pits, out of doors, or in cellars, buried in moist sand. The roots are pulled and the tops cut about an inch long. The roots should be kept in storage at about 33° F.

#### IV. CABBAGE

**Planting.** Cabbage is a transplanted crop, the seed being planted in greenhouses or hot beds for the first crop and in a protected location out of doors, or in a hot bed, for the later crop. The plants are ready for transplanting when six to eight weeks old. For early planting, the seed should be sown about March first and transplanted to two by two inches when the first true leaves appear. The plants may be set in the field as soon as the ground can be gotten in condition in the spring. If properly hardened before planting out, they will stand frost without any damage. The seed for the late crop is generally planted about June first. The seed should be planted in a protected location but the plants need not necessarily be transplanted until ready for the field. The selection of the seed for the cabbage crop is most important in order that the strain or type of head desired may be produced.

Planting distances vary with the variety of cabbage grown. Early varieties may be set as close as fifteen by twenty-eight inches, the later sorts should be set farther apart up to twenty-four by thirty-six inches.

**Soil.** Cabbages do best in the heavier, cooler kinds of soil, plenty of moisture being of great importance for the



FIG. 26.—Companion Cropping, Cabbage and Lettuce.

successful growing of this crop. The ground should be well prepared before planting cabbages.

**Cultivation.** Cultivation should begin as soon as the plants are set in the field and continue as long as the spreading plants will permit.

**Harvesting.** The time of harvesting depends upon the size of heads desired. The grower is largely influenced by the market conditions. Small heads may often be cut to advantage, particularly if the cabbage are sold by the head; however, it seldom pays to cut small heads for sale by the barrel.

The heads are usually gathered by cutting them off with a butcher knife. The outer leaves should be broken down, the head pushed to one side and the stem cut close to the head. For immediate sale, the outer leaves should all be removed, but when the cabbage are to be stored, some or all of the outer leaves should be retained. When stored in pits, the stump is pulled with the head and the whole plant placed in the pit. Cabbages to be stored in cellars are gathered with some of the outer leaves on and placed in narrow, well ventilated bins. The temperature should be kept at 33° F.

There are a number of types of cabbage grown, the most common of which are Wakefield, Flat Dutch, Ball Head, Savoy and Red Cabbage. The Wakefield group contains the earlier varieties, the other types contain the later varieties.

**Fertilizers.** Cabbages are gross feeders and need an abundance of quickly available plant food for their proper development. Fifteen to twenty-five cords of manure per acre should be ploughed under and a dressing of 1500 to 2000 pounds of a high grade complete fertilizer applied just previous to the final harrowing. An application

of 150 pounds of nitrate of soda may be made with benefit after the plants have been set three to five weeks.

#### V. BRUSSELS SPROUTS

Brussels sprouts require about the same treatment as do cabbage. They require a somewhat longer period for development than is required for late cabbage and the plants should be set in the field at least ten days earlier than the late crop of cabbage. Brussels sprouts are a hardy crop and the main cutting does not occur until late in the fall. In some localities the cutting continues throughout the winter.

The little heads develop in the axils of the leaves and the crop is gathered as it matures, several cuttings being had from each plant. The lower leaves should be broken or cut off as the heads develop. When the climate is severe the plants may be lifted and planted in loam or sand in cellars. Such a practice is not of general use but is confined to small crops or for family use.

The plants should be set the same distances as for cabbage, the ground being rich in quickly available plant food. The sprouts are ready for cutting as soon as of proper size. They are usually marketed in small baskets such as strawberry baskets. The top layer should be carefully faced.

#### VI. CAULIFLOWER

**Soils.** Cauliflower can be grown successfully on a variety of soils. It does best on rather heavy, clayey soils, and attains to its highest development in such soils, particularly if planted near a large body of water. Low lands bordering lakes or the ocean, are very favorable locations for growing cauliflower.



FIG. 27.—Brussels Sprouts.

**Planting.** For the early crop, the seed must be sown in hot beds or in a green-house, about March 1st. The seedlings are transplanted to two inches apart. The soil in which the seeds are sown and in which the seedlings are transplanted, must be carefully selected so that no damping off fungi are introduced. Soil sterilization is sometimes resorted to that the soil may be free from diseases.

The seedlings must be grown under the most favorable conditions that they may not in any way be checked; plants that have been checked produce small, imperfect heads. The plants should not be set in the field until danger of hard frosts is passed. Planting distances vary from two by three to three by three and one-half feet depending upon the variety grown and the kind of cultivation to be practised.

**Fertilizers.** Cauliflower requires an abundant supply of quickly available plant food. A heavy application of rotted stable manure should be ploughed under, and from 1000 to 2000 pounds of a high grade, complete fertilizer should be harrowed in previous to setting the plants in the field. After the plants are well established, nitrate of soda at the rate of 150 to 200 pounds per acre, should be sown along the rows, or broad casted, two or three times during the growing season.

As soon as the heads begin to form, the outer leaves should be drawn together over the head and tied with raffia or string. This is done to protect the head from rain and sunlight, in order to produce clean, white heads.

**Harvesting.** Cauliflower may be cut at any time after the heads are of sufficient size to supply the demands of the market or consumer. The heads should be cut low enough and with enough stump so that they will have a layer of leaves surrounding them. The leaves are trimmed off even with the head or a little beyond it. The leaves



serve as a protection for the heads in shipment and handling.

Cauliflower is marketed in barrels, bushel boxes and crates.

## VII. CELERY

**Planting.** In the North, the seed for the early crop should be sown from March 1st to March 15th. The seed should be sown in flats containing finely prepared soil well filled with humus, the seed being very small, and the seedlings not strong enough to push through soils that will pack with watering. As soon as the plants are about one inch high, they should be transplanted to two inches apart each way, in flats containing rich soil well supplied with humus.

Seed for the late crop may be sown in the open as soon as the ground can be prepared in the spring.

**Distance.** The distance between plants in the row in the field is from four to twelve inches, depending upon the variety of celery grown. The early or smaller sorts may be set closer than the late or winter varieties.

The distance between rows varies with the varieties and the manner of blanching the celery.

Early celery that is to be blanched by staking boards, or heavy paper, against the plants, may be set in rows twenty-four to thirty inches apart. Late celery that is to be blanched, or partly blanched, by banking with earth, should not be set in rows closer than four feet, that there may be sufficient soil to plough up to the plants.

**Planting.** The plants should not be set in the field until danger of hard frosts is passed. Mature plants will stand slight freezing with little danger, particularly if covered with soil, but if the plants are severely frosted their keeping quality is impaired.



FIG. 28.—Digging Celery with a Spading Fork.

A good plan for planting early and late celery is to set the two kinds in alternate rows two feet apart. The early celery is to be blanched with boards, or heavy paper, staked against the plants. The early celery is harvested before the late celery needs much banking, leaving the late celery in rows four feet apart.

**Fertilizers.** Celery is a heavy feeder on nitrogenous fertilizers, and applications of at least 25 cords per acre of rotted manure should be made for this crop. A complete high grade fertilizer, containing 4-8-10, should be applied at the rate of 1500 to 3000 pounds per acre previous to planting. Nitrate of soda should be sown along the rows at the rate of 200 pounds per acre at intervals after the plants are well established.

**Cultivation.** The ground should be kept thoroughly cultivated from the time that the plants are set in the field until the time of harvest. Celery requires large quantities of water, and unless there is a sufficient normal supply, irrigation must be practiced to insure a good crop.

**Harvesting.** Celery is ready for harvesting as soon as sufficiently blanched, so long as the plants are of sufficient size. The plants may be dug up with a spade, as in Fig. 28, or ploughed out, or dug with a small tree digger which straddles the row as shown in Fig. 29. The tree digger is very effective in harvesting celery on a big scale. It loosens the plants, cutting off only a small part of the roots, and does not break the stalks as is usually the case when the plants are ploughed out.

**Preparing for Market.** The roots are trimmed off to a wedge shape, the unblanched or broken stalks are stripped off, and if the plants are small, several of them are tied into a bunch. Celery should be thoroughly washed before bunching or packing for market.



FIG. 29.—Digging Celery with a Small Tree Digger.

**Blanching.** As has been indicated, celery may be blanched by banking with soil, or by staking boards, or heavy paper along the rows. Early celery cannot often be successfully blanched by banking with soil, but must be blanched with boards or paper. Blanching must begin in warm weather, and banking with soil at this time will cause the celery to rust. The lumber used for blanching should be good, straight boards one foot wide, ten to twelve feet long. The boards are placed against the plants and drawn together at the top and held in position by staking, or by forcing stiff, heavy pieces of wire, bent into the shape of a hairpin, down the outside of the boards. Recently, a heavy grade of paper, similar to prepared roofing, has been on the market, cut one foot wide and in varying lengths. The cost is about \$15.00 per thousand feet. The paper also is held in place by using heavy wire hairpins, and is considered equal to boards for blanching. It is easy to place in position, and can be rolled up and stored in a small space in the fall.

Late celery is blanched, or partly blanched, in the field, by banking with soil. The soil may be ploughed up to the plants with a plough or a wing cultivator. A celery banker is an effective implement to use in ploughing the soil up to and against the plants. It has a wire guard that forces the tops back and holds them in place until the soil has been pushed against the plants.

**Storing.** Celery to be blanched in storage is only partly blanched in the field. The plants are lifted with most of their roots, and after the broken and crooked stalks are stripped off, the plants are placed in cellars, pits, or any building where the roots can be set in moist soil and the temperature kept low. Just above the freezing point is the most desirable temperature. The plants should be set as



FIG. 30. - A Field of Cucumbers.

closely together as possible, the roots being covered with soil. The plants should be held in place by staking up boards and setting the plants against them. It is a good plan to leave an alley six inches wide every ten to twelve feet, to provide good air drainage. The air surrounding the plants should be kept moist, and if the plants become too dry, water the soil, being careful not to wet the plants more than is necessary. Celery will continue to grow and to blanch in storage if the temperature is kept a few degrees above freezing.

### VIII. CUCUMBERS

**Soil.** In the lighter soils, cucumbers will produce earlier, but in the heavier soils the bearing will be heavier and over a longer period. The soil should be thoroughly cultivated before planting the seed.

**Planting.** The seed should not be planted until danger of frosts is passed. A plan followed by some growers is to plant early and make successive plantings a week apart; all plants not required are afterwards cut out with a hoe.

The seeds may be planted in hills or in drills, the distance between hills being four by five to six by six feet. Plants in the drill are thinned to twelve to sixteen inches apart.

**Fertilizer.** The soil should be well manured before ploughing, and just previous to the last harrowing before planting, 1000 to 2000 pounds of a high grade, complete fertilizer should be applied.

The cucumber requires potash and phosphoric acid to insure fruitfulness; a 4-8-10 fertilizer is well adapted to this crop.

**Harvesting.** When cucumbers are grown for pickles, the picking should begin as soon as the fruits are of the



FIG. 31.—Harvesting Dandelions with a Shuffle Hoe.



desired size. For slicing, cucumbers should not usually be gathered until at least six inches long. Whether the cucumbers are grown for pickles or for slicing purposes they should be gathered at least twice a week to secure uniformity in the size of the fruits.

**Cultivation.** Cultivation should begin as soon as the plants break the ground and should continue as long as possible without too great injury to the vines.

## IX. DANDELION

**Planting.** The dandelion is a hardy crop and may be planted early in the spring or in the early fall for spring cutting. When grown in the fall, the seed should be sown early enough so that the plants will be nearly full grown by the time hard freezing weather occurs. It is desirable to mulch lightly with straw, although mulching is not necessary for the successful wintering of this crop.

**Soil.** The leaves are the edible portion of this plant and the ground selected for dandelions should be rich and friable. The seed should be planted in rows sixteen to eighteen inches apart, and when planted in the rows for growing to maturity the seedlings should be thinned to at least six inches apart. The seed may be planted in a seed bed and the plants transplanted as desired.

**Harvesting.** Fall grown dandelions are ready for harvesting as soon as the season opens in the spring. They may be cut with a knife by hand or by the use of a sharpened shuffle hoe as shown in Fig. 31. The plants should be carefully washed and packed in bushel boxes or baskets for marketing.

## X. EGG PLANT

**Soil.** The lighter soils only are adapted to the growing of egg plant, heavy soils being too cold for this vegetable. The soil should be rich in humus, should be deep, and should have a southern exposure to insure warmth.

**Starting the Plants.** The egg plant must be started under glass, to be ready for the field by early June. The seed should be sown in flats, or a good seed bed, about the middle of March and the seedlings should be pricked out to two by two inches. The temperature must be kept high, not less than 65° F. at any time. The plants must maintain a steady growth; if checked in any way the yield will be far short of normal.

**Planting.** The plants should not be set in the field until the ground is thoroughly warmed. The distance between plants should be two by three to four by four feet.

**Fertilizer.** A liberal supply of nitrogen is necessary for the quick growth of the plants. The soil should be rich in humus; at least 20 cords to the acre of rotted manure should be ploughed under. An application of 1000 to 2000 pounds per acre of a high grade, complete fertilizer should be made and harrowed in previous to planting. A top dressing of nitrate of soda, at the rate of 200 pounds per acre, may be made after the plants have become well established.

## XI. HORSE-RADISH

**Desirability.** In old-fashioned gardens, horse-radish was considered one of the essential vegetables and its popularity still exists, the ground-up roots mixed with vinegar being much relished as a sauce with cold meats and shell fish. In the home garden, horse-radish is usually grown in



FIG. 32.—A Field of Horse Radish.

a corner, or beside a fence out of the way, where it is allowed to grow at will.

**Planting.** Commercially, this crop is grown quite extensively in some sections. The method of propagation is to plant the small side roots with a dibble. Any piece of root, an inch or more long, will produce a plant and root of good size. The most desirable size root for planting is a piece the size of a lead pencil, four to six inches long.

Horse-radish may be grown as a main or as a companion crop. When grown as a main crop, the roots are set in rows twenty-four to thirty inches apart, and the roots set ten to twelve inches apart in the row. Horse-radish and early cabbage make excellent companions and are largely so grown in the Eastern states. The cabbage and horse-radish being set alternately in the row, the cabbages mature and are out of the way so that the horse-radish has the land to itself during the latter part of the season.

**Harvesting and Marketing.** The roots are ploughed out in the fall and the tops are trimmed off. The roots are then buried in moist sand to await manufacture into sauce. The larger roots are ground up, the smaller roots being saved for propagation. Some growers sell the roots while others grind up the roots and bottle the product. The market is limited for horse-radish, but, in favorable locations, it is a profitable crop. The yield varies from three to five or six tons per acre and the price varies largely with the season, the quality of the roots and the demand for them.

## XII. LETTUCE

**Soil.** Lettuce may be grown successfully in most soils, if well supplied with rotted manure and liberally fertilized with high grade, chemical fertilizers. Light sandy



FIG. 33.—Companion Cropping; Cabbage, Green Onions and Lettuce.

soils that have had heavy dressings of manure are best adapted to growing this crop.

**Starting the Plants.** Lettuce may be transplanted or grown to maturity where sown. For transplanting, the seed should be sown eight to ten weeks before the plants are to be set in the field. The seed should be sown in flats or in a seed bed and the seedlings should be grown under rather cool conditions.

**Planting.** The plants may be set in the field as soon as the ground can be gotten into shape in the spring. The plants should not be set less than a foot apart each way in the field. In hot beds or cold frames, the distance is usually nine by nine inches.

**Fertilizer.** Heavy applications of rotted manure should be ploughed under. Lettuce does very well, however, if rather fresh manure is used. In any event, for best results, the soil should be well filled with humus. An application of 1000 to 2000 pounds of a high grade complete fertilizer should be made and harrowed in previous to planting. Top dressings of 200 pounds of nitrate of soda to the acre should be made at intervals, after the plants are well established.

**Season.** Lettuce is a cool weather crop and should be grown only in the spring and fall for heading purposes. The plants will stand several degrees of freezing with no harm, if they have been well hardened before setting in the field.

**Harvesting.** Lettuce is commonly gathered by pulling up the plants, which are then taken to the packing shed and thoroughly washed, after which the roots are cut off, smoothly, just below the lowest leaves. After washing and trimming, the plants are put into crates, baskets or boxes, for shipping to market.

**Varieties.** There are two general types of lettuce;

*head lettuce* and *loose leaf*, or non-heading lettuce. What variety shall be grown is a question to be decided by the market demands. Tennis Ball and the numerous strains of this variety are generally grown for head lettuce. Grand Rapids and other loose leaf varieties are grown for loose headed lettuce. Cos Lettuce is an excellent kind rapidly coming into favor. It is an upright grower with a compact head. The leaves are crisp and tender, and possess a fine flavor.

### XIII. MUSKMELON

**Soil.** Muskmelons may be grown successfully on a variety of soils, but the lighter soils, well filled with humus, are preferred. Climatic conditions are apparently of more influence than soils on this crop, the muskmelon not standing frosts. Hot days and warm nights are very favorable for its rapid development. Care must be had that sufficient water is available at all times as a lack of moisture is sure to cause weakened plants and fruits of small size. In the West, where alkali is present, irrigation must not be too late or the flavor of the fruit will be hurt.

**Planting.** Plant the seed in the open only after all danger of frost is passed. To secure the earliest results, successive plantings at intervals of a week may be made, and the undesired plants may be pulled or hoed out.

A plan followed by many growers is to start the seed in pots or small baskets, not over four weeks before the time for setting the plants in the field. The plants are grown in hot beds or green-houses, and the temperature during the last week is kept as nearly as possible the same as that prevailing in the field.

The plants are carefully removed from the pots or baskets with all the earth in which they have grown, care being taken

that the ball of earth is broken or disturbed as little as possible. Plants started early will produce marketable fruits a week to ten days ahead of their normal season.

Planting distances vary from five by five to six by seven feet. The common practice is to plant six by six feet. Do not make hills; level culture is preferable.

**Picking.** For a local market, the fruit may be allowed to remain attached to the vines until fully ripened. For long shipments, the fruit should be gathered as soon as it may be separated from the vine. As ripening occurs, the stem gradually loosens its attachment to the melon, and when fully ripe, it will often become detached because of the weight of the vine alone.

**Fertilizer.** Stable manures are the best sources of plant food for the muskmelon, the plants doing best in soils containing an abundance of organic matter. Care must be taken not to fertilize too heavily with nitrogenous fertilizers. An excess of nitrogen causes large growth of vine at the expense of fruitfulness.

A high grade, complete fertilizer should be applied at the rate of about 1000 pounds per acre, just before planting.

#### XIV. ONIONS

**Soil.** Rich bottom lands, composed of fine alluvial soil, are especially desirable plots in which to grow onions. Muck or peat soils also give excellent yields of onions, and large areas of such soils are now used for the production of this vegetable. The lighter or sandy loams are very desirable for onion growing if they contain plenty of organic matter. Clay or silt soils are not desirable because of their tendency to bake and pack after the seed are sown.





FIG. 34.—Wheel-hoeing Onions.

The soil should be very thoroughly prepared. Fall ploughing is universally practiced in onion growing sections.

**Planting.** The bulk of the onion crop is produced from seed sown in the spring. Sowing should begin as soon as the ground can be gotten in proper condition. The seeds are sown with a hand drill in rows, twelve to sixteen inches apart, when hand cultivation is practiced. For horse cultivation, the rows should be twenty-four to thirty inches apart. A small well-trained mule may be used to cultivate in rows as close together as eighteen inches.

The amount of seed to use per acre will depend upon whether the land is favorable to the growth of the seedlings, the season and the quality of the seed. The seed should always be tested to determine its viability. When good seed is used and the rows are fourteen inches apart, four pounds of seed per acre should be sufficient.

Early onions are grown from sets, which may be planted in the fall or spring. Tree onion sets may be planted in the fall. Sets grown from seed sown very thick, so as to produce very small bulbs, should be planted in the spring. The sets planted in the spring should be placed in the ground as soon as it can be gotten into shape for planting. Fall planted sets should be put out four to six weeks before hard freezing weather.

Sets are planted for bunching onions, or for the production of early mature onions. Bunching onions are also grown from seed.

**Cultivation.** The cultivation should begin even before the seedlings appear, and should continue throughout the growing season. The cultivation should be shallow so as not to disturb the onion roots, which are close to the surface.

Onion cultivation is carried on almost entirely by hand

labor. At the first weeding, the surplus seedlings should be removed so that the plants will stand about two inches apart in the row. Hand-wheel hoes, Fig. 34, either single or double-wheel, are necessary for cultivating onions grown in narrow rows.

**Onion Sets.** Onion sets are produced by sowing seed very thickly on the ground not very rich nor too well supplied with moisture. The seedlings have to compete so severely with one another and against unfavorable conditions, that the bulbs never attain to any great size. As soon as the tops begin to turn yellow, the sets are harvested, dried and topped.

Multiplier or Perennial Tree onions produce sets on their tops. These are used the same as sets grown from seed. As has been indicated, Perennial Tree onions are very hardy and may be planted in the fall, six to eight weeks before hard freezing weather sets in. After the ground freezes, the sets should be covered with a light mulch of straw or strawy manure.

**Harvesting.** Onions for bunching, should be pulled as soon as the bulbs are of sufficient size. The number of plants to the bunch will depend upon the size of the plants and upon market requirements.

Dry onions should be allowed to ripen until the tops die down before being pulled. The general practice, however, where large areas are to be harvested, is to begin pulling the onions as soon as the tops are yellow. The onions are pulled and thrown into a windrow. The onions are allowed to dry, or cure, in the windrow for several days, or until the tops are dry enough to easily be twisted off. They are then ready for topping, grading, sacking, and storing.

Onions in storage, require cool, dry conditions. The



FIG. 35.—A Good Crop of Onions. The curing shed is shown in the background.

temperature should not drop below 32°, about 35° being the best temperature to maintain.

**Transplanting Onions.** The Spanish type of onions are profitably grown by transplanting seedlings that are six to eight weeks old. The seed may be sown in a hot bed or green-house. The seedlings should be kept topped to about four inches, to produce strong plants. Before setting in the field, the plants should be cut back to about three inches, and the roots trimmed off. The plants should be set not closer than four inches in the row in the field.

**Varieties.** The Danvers Yellow Globe, and the Southport, Red, White and Yellow Globe, are the favorite varieties to grow from seed in the North. The Prizetaker is the favorite for transplanting. The globe onions do not transplant profitably.

**Fertilizers.** Stable manures are valuable sources of plant food for onions, if the manures are previously composted and are applied only when rotted. Manures containing coarse material should not be used. The onion is a shallow rooted vegetable and requires an abundance of quickly available plant food. Chemical fertilizers are, therefore, very generally used in growing onions. High grade, complete fertilizers, containing at least 4% of nitrogen should be used. The formulas used by different growers vary considerably, but in most cases the nitrogen and potash elements are high. A fertilizer containing 5% nitrogen, 8% phosphoric acid and 12% potash, should be applied at the rate of 1000 pounds to 2500 pounds per acre, depending upon the condition of the soil. A top dressing of nitrate of soda, at the rate of 150 pounds per acre, may be applied after the plants are four to six inches high.

### XV. PARSNIP

**Soil.** Sandy loam is best adapted to the growing of parsnips. Heavy soils tend to produce roots irregular in shape and with numerous fibrous roots.

**Planting.** The seed should be sown in drills as soon as the ground can be gotten into shape in the spring. The rows should be sixteen to twenty inches apart and the plants four to seven inches apart in the row, depending upon the richness of the soil and the size of the roots desired. The whole season is required to mature this crop.

**Harvesting and Storing.** The roots are dug out in the fall and the tops cut off about one inch above the crown. The roots are then ready for storing. In digging the roots, it is a good plan to plough along one side, or both sides of the row, ploughing away from the plants. This leaves the roots partly exposed and easily dug.

The roots may be stored in pits out of doors, or in cellars. If stored in a cellar, the roots should be kept buried in moist sand to prevent their shrivelling.

Parsnips are hardy and may be left in the ground over winter. The claim is often made that freezing improves the quality.

### XVI. SALSIFY

This vegetable, because of its flavor, is generally known as "oyster plant." Its cultural requirements are the same as for the parsnip.

### XVII. PEA

**Soil.** The pea does well on a variety of soils if well supplied with humus. The lighter soils are best for early results, but for the main crop and heavy yields, heavier soils are best.

**Planting.** The pea is a hardy, cool-loving plant and the seed should be sown as soon as the ground can be worked. The seed is usually sown in drills eighteen to thirty inches apart, for a garden crop. As a field crop, as when grown for canneries, the rows may be thirty-six inches apart, or as is often done, the seed is sown with a grain drill and the crop cut with a mowing machine. The depth of planting varies from one to two inches, depending upon the season and the soil. The earlier and cooler the season the shallower should the planting be, while if the season is advanced, or the soil light, the planting should be deeper.

**Fertilizers.** The pea requires but little nitrogenous fertilizer, but should have a liberal application of a high grade, complete fertilizer, containing 2% to 3% nitrogen, 8% of phosphoric acid and 10% of potash. Rotted manure should be applied at the rate of 20 cords per acre and ploughed in.

**Varieties.** Peas are divided into two general types: *smooth peas* and *wrinkled peas*. The smooth peas are the hardier of the two, and are adapted for use as a field crop or a garden crop. The wrinkled peas are less hardy than the smooth peas, have finer flavor and are not adapted for field purposes.

The varieties may be divided into two groups, comprising the dwarf sorts and the tall or bush sorts.

Gregory's Excelsior, Gradus, Nott's Excelsior, and Thomas Laxton are excellent early varieties.

Telegraph and Stratagem are fine late varieties.

**Harvesting.** Peas are ready for harvesting as soon as the seeds are large enough to "shell" easily. The garden varieties are always gathered by hand. Two or more pickings are required, and care must be exercised that the peas

do not become too hard before being gathered. Half bushel and bushel baskets and bushel boxes are commonly used for marketing peas.

The tall varieties may be supported in a number of ways, brush being most commonly used. The brush should be cut as long as desired and thrust into the ground along the rows. Wire trellis, or chicken wire, may also be used for supporting the vines.

### XVIII. RADISH

The radish is one of the most popular and easily grown vegetables that we have. In the early season particularly is the radish in great demand. As a market garden crop the radish is almost always grown as a filler or companion crop, but in the home garden the radish is generally given a first choice when the collection of seed for planting is being selected.

The radish is a hardy crop and gives quick returns. It is a cool-loving plant and may be planted as soon as the ground can be prepared in the spring. As a greenhouse or hot bed crop it is a universal favorite because of the ease and quickness with which it is brought to an edible size.

**Seed.** The seed of the radish should be carefully selected, only the largest and plumpest seed should be planted. Small, inferior seed will produce a crop of small size and inferior quality and shape of roots. The seed may be cleaned by running it through a fanning mill or by screening. The openings in the screen should be  $\frac{2}{5}$  of an inch in diameter. Plants from the largest and best seed can be matured in from twenty-one to thirty-six days; plants from small seed will take from six to fourteen days longer to reach maturity.



**Planting.** The seed should be covered to a depth of from one-half to three quarters of an inch. It is desirable for quick germination that the ground be thoroughly prepared and have a sufficient amount of moisture. If planted by hand, the seed should be dropped about one-half inch apart. Machines are properly gauged for planting radish seed if set as directed. The soil should be firmed over the seed after planting to bring the moist earth in direct contact with the seed. To obtain the finest quality, the radish should be grown as rapidly as possible and with plenty of moisture at all times.

**Marketing.** Radishes are ready for pulling as soon as they reach sufficient size. The plants are tied into bunches of from six to ten plants each according to size and the season. They are then carefully washed and packed in bushel boxes or baskets for the market.

The Scarlet Globe and strains of this variety are the most profitable and popular sorts to grow.

## XIX. RHUBARB

**Soils.** Rhubarb can be grown profitably on most soils, if sufficient humus and plant food are supplied. For early results rhubarb should be planted in sandy loam, with a southern exposure.

**Propagation.** Rhubarb can be propagated from seed, but this procedure is not very satisfactory because the seedlings seldom come true to the type desired. The best method is the division of the old roots; each piece of root with an "eye," or bud, will produce a plant of the desired qualities.

**Planting.** The best results are obtained from planting in the spring. The soil should previously have been

well supplied with manure. The usual planting distance is four by four feet, and the eyes or crowns should be covered to a depth of six to eight inches.

**Fertilizers.** Rotted stable manure is the best source of plant food for rhubarb. This should be supplemented by an application of 1000 pounds or more of a high grade, complete fertilizer, containing 6% of the nitrogen element. Nitrate of soda should be applied at intervals during the growing season, at the rate of 150 to 200 pounds per acre. Some fertilizer should be applied after the pulling season is over, in order that the roots may store up plant food for the next year's crop. Mulching with rotted manure is quite generally practiced and is very beneficial.

Thorough cultivation should be practiced throughout the growing season, and irrigation is advisable unless the natural supply of moisture is sufficient. Rhubarb requires large quantities of water and no other crop gives quicker response to irrigation.

**Harvesting.** The stalks are pulled as soon as they have attained sufficient size, and after the leaves are trimmed off close to the stem, the stalks are tied into bundles of several stalks each.

**Forcing.** Rhubarb is forced in the winter time by bringing the large roots into a warm, darkened room or cellar. The roots are set in soil and kept sufficiently moist. The roots should be dug out in the fall and stored in a cool place. Freezing is claimed to be an advantage. When forced in the dark, fine large stalks, surmounted with very small leaves are produced. The roots are worthless after having been forced.

## XX. SPINACH

Spinach is one of the easiest grown and most popular of the salad crops. It is unexcelled for boiling. A home garden is not complete without it.

**Planting.** The seed may be planted in the spring as soon as the ground can be prepared, or planting may take place in the early fall. Spinach is a cool-loving plant and does best only during the cooler parts of the season.

The seed should be sown in drills sixteen to eighteen inches apart. When fall sowing is done to produce a crop for the spring harvest, it is a good plan to make beds somewhat higher than the general level of the ground, that the plants may have proper drainage. The beds should be wide enough for six or more rows of spinach. As freezing weather approaches, the plants should be covered with straw or strawy manure, to prevent successive freezing and thawing which would tend to lift the plants and destroy them. As soon as the spring opens, the mulch should be removed.

**Harvesting.** The plants are usually harvested by cutting the tap root just under the surface of the ground. This is easily accomplished with the use of a sharpened hoe. The outer leaves should be removed and the plants washed before packing for market. For a local market, the bushel box is a favorite package, but for shipping to a distant market, the barrel or bushel basket should be used. The barrel should be covered with burlap but the basket should have a slatted cover.

**Fertilizers.** The ground must be well fertilized that the plants may make a maximum growth. Heavy applications of rotted manure and a dressing of a complete high grade, chemical fertilizer should be made previous to sowing the seed.

## XXI. SQUASH

**Soil.** A well fertilized, medium to light soil is the most desirable in which to grow squashes. The success in growing the crook-neck or patty-pan type of squash is dependent to a large degree upon having a soil that will warm up early in the spring. This is no less true with the Hubbard squash and other varieties that require a long growing season to attain maturity before frosts in the fall.

**Planting.** The general practice is to plant in hills from four by four feet, for the crook-neck and patty-pan types to ten by twelve feet for the Hubbard squash. The seed should not be planted until danger of frost is passed and the ground has become sufficiently warmed.

To obtain earliest results, the seed may be planted in pots or baskets, in a hot bed or green-house, four to six weeks before being set in the open. When transplanting, great care must be taken that the ball of earth is disturbed as little as possible.

**Harvesting.** The summer squashes are harvested as soon as they attain sufficient size to become salable.

The fall and winter kinds should be allowed to ripen on the vines before being harvested. The squash should be gathered with all of its stem intact; the vine should be cut about an inch each side of the stem. Unless the weather is too severe, the squashes may be left piled in the field until the stems have become thoroughly dried before being placed in storage.

**Storing.** The storage must be warm and dry, the temperature being held at 50° to 55° F. It is customary to have stove or furnace heat in squash store-houses. The squashes keep best when stored on ventilated shelves, piled

not more than three deep. The bottom shelf should be at least one foot from the floor to provide good air drainage.

## XXII. SWEET CORN

**Soils.** Sweet corn can be grown successfully in any fertile soil, but the best results are obtained in newly broken sod land, or in sod land ploughed in the fall previous to growing the corn.

**Planting.** The earliest sweet corn brings the highest prices, the grower should therefore select such lands as warm up earliest in the spring, and plant early, making successive plantings until danger of frost is past, when the undesired plants are hoed out. A succession of crops are obtained by planting such varieties as will give succession, or by planting one variety of corn at intervals during the season. Sweet corn is usually planted in drills thirty inches to four feet apart. The distance between plants in the rows should vary with the variety from ten inches for the smaller growing kinds to a foot or more for the larger growing kinds. When grown in hills, two to three plants in a hill are sufficient.

**Transplanting.** Sweet corn can be transplanted successfully and profitably if handled properly. The seed should be planted in pots or baskets not over four weeks previous to setting in the field. In transplanting, great care must be taken not to disturb the roots. Two plants in a three-inch pot are as many as should be grown. Each pot should provide plants for one hill.

**Fertilizer.** Rotted stable manures applied at the rate of 20 cords to the acre are very desirable sources of plant food for corn. Chemical fertilizer containing 4% nitrogen, 8% phosphoric acid and 10% potash should be applied at the rate of 1000 to 2000 pounds per acre.

**Cultivation.** Frequent and thorough cultivation should be practiced, horse-drawn implements being used until too much damage is done the growing crop.

**Varieties.** Golden Bantam, Crosby and Red Cob Cory are good early varieties. Country Gentleman and Stowell's Evergreen are the most popular and desirable of the later varieties.

### XXIII. TOMATOES

**Soil.** The tomato can be grown successfully on most soils, provided they are fertile and well drained. On the lighter soils, such as sandy loams, the earliest fruits are produced, but the fruit usually is not so firm and meaty as when it is produced on heavier soil. The yield is usually somewhat heavier on the lighter soils than it is on the heavier soils.

**Planting.** For earliest results, the seed must be sown under glass about the first of March. The seedlings may be transplanted into flats being set three by three or four by four inches, or they may be set in pots or berry baskets. A three-inch pot is suitable for the first transplanting. As the plants become larger and the roots begin to fill the pots, they should be shifted into larger pots. This procedure should be repeated until the conditions are right for setting the plants in the field.

The first bud cluster should be pinched out. This will cause the plants to branch out and the formation of several bud clusters in place of the one removed. If the plants are well handled and have not been allowed to crowd or become spindly, they may have blossoms or small tomatoes on them when set in the field. If the transplanting is done carefully, and the plants have been properly hardened, the blossoms and small fruit will continue to develop normally.

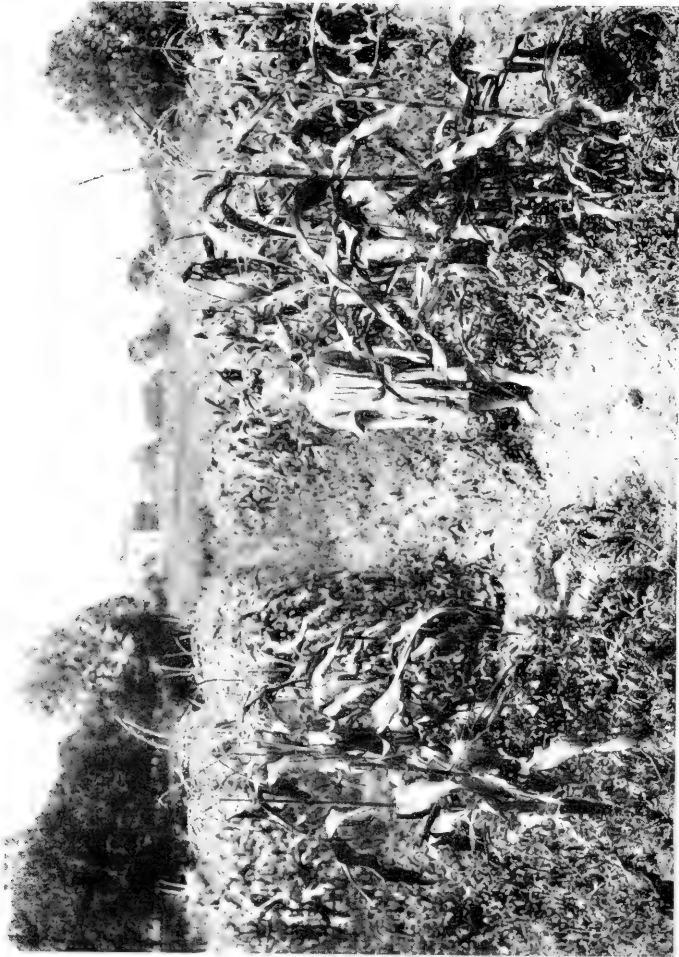

FIG. 36.—Companion Cropping; Tomatoes and Corn.

Fruit from such plants can be had in forty to forty-five days.

**Fertilizers.** The soil should be liberally supplied with rotted manure, ploughed under and thoroughly incorporated with the soil by discing. A high grade, complete fertilizer, containing 4% nitrogen, 8% phosphoric acid and 10% potash, should be applied at the rate of 1000 to 2000 pounds per acre just previous to setting the plants in the field.

**Training.** In general practice, the plants are set three by three to four by five feet apart, and the plants are allowed to rest on the ground as they become larger and bear fruit. Pruning the vines and training them to stakes is sometimes practiced in the field. When the plants are to be staked and pruned, they should be set eighteen inches apart in the row. A stake is provided for each plant and the plant is kept pruned to a single stem. After a sufficient number of clusters of fruit have been set, the top of the plant is cut off. As the lower leaves become old and spotted they should be pruned or entirely cut off. It is an advantage to shake the plants every day when they are in blossom to aid in setting the fruits.

**Harvesting.** Tomatoes, whether grown for a local or distant market, should be gathered before becoming entirely ripe. At the height of the season the fruit should be gathered every day.

Tomatoes are marketed in small splint baskets holding five to ten pounds each, also in bushel boxes and baskets.



## INDEX

- Asparagus, 53-56.  
  blanching, 55.  
  cultivation, 54.  
  fertilizers for, 55.  
  harvesting, 55.  
  planting, 53, 54.
- Bacteria, 10.
- Beans, 56, 57.  
  cultivation, 56, 57.  
  fertilizers for, 57.  
  harvesting, 57.  
  planting, 56.  
  supports for, 56.  
  varieties, 57.
- Beets, 57-61.  
  fertilizers for, 59, 61.  
  marketing, 59.  
  planting, 59.  
  soil for, 57.  
  storage of, 61.  
  transplanting, 59.
- Blanching, 55, 67, 71.  
  asparagus, 55.  
  celery, 67, 71.
- Brussels Sprouts, 64.
- Bushel baskets, 50.
- Bushel box, 48.
- Cabbage, 61-64.  
  club foot, 16.
- Cabbage, cultivation, 63.  
  fertilizers for, 63.  
  harvesting, 63.  
  planting, 61.  
  soil for, 61.
- Catch Crops, 18.
- Cauliflower, 64-67.  
  fertilizers for, 66.  
  harvesting, 66.  
  planting, 66.  
  soils for, 64.
- Celery, 67-73.  
  blanching, 71.  
  cultivation of, 69.  
  fertilizers for, 69.  
  harvesting, 68, 69, 70.  
  marketing, 69.  
  planting, 67.  
  storing, 71, 72.
- Combination tools, 3, 8.
- Companion Cropping, 20, 62,, 79  
  97.
- Composting, 10, 11
- Crates, 48.
- Cucumbers, 73-75.  
  cultivation, 75.  
  fertilizers for, 73.  
  harvesting, 73, 75.  
  soil for, 73.
- Dandelion, 75.

- Dandelion, harvesting, 74, 75.  
Dibbers, 30.  
Disc harrow, 5.  
Dust mulch, 5.
- Egg Plant, 76.  
    fertilizer for, 76.  
    planting, 76.
- Exposure of Gardens, 2.
- Fertilizers, 9-18.  
    chemical, 12-15.  
    commercial, 11.  
    complete, 15.  
    composting, 10.  
    hot manures, 10.  
    kinds, 9.  
    stable manure, 9, 10, 11.
- Fire fanging, 11.
- Gardens, 36-42.  
Germination, 25.  
    conditions for, 27.
- Horse radish, 76-78.  
    harvesting, 78.  
    planting, 78.
- Hot beds, 19-23, 36.  
    care of, 23.  
    construction, 21, 22.  
    heating, 19.  
    location, 19.  
    manure for, 21, 22.
- Humus, 10.
- Irrigation, 32-36.  
    amount of, 35.  
    furrow, 34.  
    methods of, 33, 34, 35.
- Irrigation, requirements, 32.  
    sprinkler system, 34, 35.
- Labor, 2.
- Legumes, 16, 17.
- Lettuce, 78, 81.  
    fertilizers, 80.  
    harvesting, 80.  
    planting, 80.  
    soils for, 78.  
    varieties, 80, 81.
- Lime, 15, 16.
- Location of market garden, 1.
- Manure, 9, 10, 11.  
    composting, 10.  
    effects of, 17.  
    green, 16.  
    kinds of, 9, 10.
- Market, 1.
- Moisture requirements, 32
- Musk melon, 81, 82.  
    fertilizer for, 82.  
    harvesting, 82.  
    planting, 81.  
    soil, 81.
- Nitrate of soda, 13.
- Nitrogen, 12-14.
- Non-legumes, 17.
- Nodules, 16.
- Onions, 82-87.  
    cultivation, 83, 84  
    fertilizers for, 87.  
    harvesting, 85.  
    planting, 84.  
    sets, 85.

- Onions, soil for, 82.  
varieties, 87.
- Packing, 49-52.  
crates and baskets, 50, 52.
- Parsnips, 88.
- Pea, 88-90.  
fertilizers for, 89.  
harvesting, 89, 90.  
planting, 89.  
soil, 88.  
varieties, 89.
- Perennials, 36.
- Phosphoric Acid, 14.
- Planting, 28.
- Ploughing, 5.  
under, 17.
- Potash, 14.
- Radish, 90, 91.  
planting, 91.  
marketing, 91.  
seed, 90.
- Rhubarb, 91, 92.  
fertilizers, 92.  
forcing, 92.  
harvesting, 92.  
planting, 91.  
propagation, 91.  
soils, 91.
- Rock phosphate, 14.
- Root crops, 43.
- Salsify, 88.
- Seed, 24-29.  
germination of, 25.  
planting, 28.  
quality of, 24.  
selection of, 24.
- Seed, sowing, 28.  
testing, 25, 27.  
viability of, 24.
- Seed beds, 27, 28.
- Seed drill, 7, 8, 42.
- Seedlings, 25, 26.  
transplanting, 29, 30.
- Smoothing harrow, 7.
- Soil, 1, 2.  
acidity, 7, 8, 42.  
of market garden, 5.  
preparation of, 15.
- Spinach, 93.
- Squash, 94.  
storing of, 94.
- Storage, 38, 43, 52.  
temperature, 48.
- Storing,  
beets, 61.  
cabbage, 38, 45, 46, 49, 68.  
celery, 45, 46, 47, 71.  
in crates, 51.  
onions, 45, 46, 85.  
parsnips, 44, 88.  
root crops, 38, 43, 143.  
squash, 94.
- Sweet Corn, 95, 96.  
cultivation, 96.  
fertilizer, 95.  
planting, 95.  
varieties, 96.
- Thomas Slag, 14.
- Tools, 42.
- Tomatoes, 96-98.  
fertilizers for, 98.  
harvesting, 98.  
planting, 96.  
soil for 96.

- Tomatoes, training, 98.  
Transplanting, 29, 30, 31.
- Vegetable garden, 36-42.  
  cultivation of, 38.  
  home, 36-38.  
  place of, 41.  
  plan of, 37.
- Vegetable garden, Plots, 39.  
  preparation of, 39.  
  school, 38-42.
- Water, 3.  
Wheel hoes, 7, 8, 42.  
Wind breaks, 2.  
Wrapping in paper, 52.

**THE WILEY TECHNICAL SERIES**

FOR

**VOCATIONAL AND INDUSTRIAL SCHOOLS**

EDITED BY

**JOSEPH M. JAMESON**

**GIRARD COLLEGE**



# THE WILEY TECHNICAL SERIES

EDITED BY

J. M. JAMESON

---

A series of carefully adapted texts for use in technical, vocational and industrial schools. The subjects treated will include Applied Science; Household and Agricultural Chemistry; Electricity; Electrical Power and Machinery; Applied Mechanics; Drafting and Design; Steam; Gas Engines; Shop Practice; Applied Mathematics; Agriculture; Household Science, etc.

The following texts are announced; others are being added rapidly:

## ELECTRICITY

### **THE ELEMENTS OF ELECTRICITY; For Technical Students.**

By W. H. TIMBIE, Head of Department of Applied Science, Wentworth Institute. xi+556 pages, 5¼ by 8. 415 figures. Cloth, \$2.00 *net*.

**THE ESSENTIALS OF ELECTRICITY; A Text-book for Wiremen and the Electrical Trades.** By W. H. TIMBIE, Wentworth Institute. Flexible covers, pocket size. xiii+271 pages, 5 by 7¼. 224 figures. Cloth, \$1.25 *net*.

**CONTINUOUS AND ALTERNATING CURRENT MACHINERY.** By Professor J. H. MORECROFT, Columbia University. ix+466 pages, 5¼ by 7¾. 288 figures. Cloth, \$1.75 *net*.

**CONTINUOUS AND ALTERNATING CURRENT MACHINERY PROBLEMS.** By W. T. RYAN, E.E., Assistant Professor of Electrical Engineering, the University of Minnesota. 40 pages, 5¼ by 7¾. Cloth, 50 cents *net*.

**ALTERNATING CURRENT ELECTRICITY AND ITS APPLICATION TO INDUSTRY. First Course.** By W. H. TIMBIE, Head of Department of Applied Science, Wentworth Institute, and H. H. HIGBIE, Professor of Electrical Engineering, University of Michigan. x+534 pages, 5 $\frac{1}{4}$  by 8. 389 figures. Cloth, \$2.00 *net*. **Second Course**, Fall, 1915.

**ELECTRIC LIGHTING.** By H. H. HIGBIE, Professor of Electrical Engineering, University of Michigan. (*In preparation.*)

**INTRODUCTION TO INDUSTRIAL ELECTRICITY.** By W. H. TIMBIE, Head of Department of Applied Science, Wentworth Institute. (*In preparation.*)

**WIRING EXERCISES.** By H. A. CALDERWOOD, Carnegie Institute of Technology. (*In preparation.*)

## HEAT AND HEAT ENGINEERING

**HEAT; A Text-book for Technical and Industrial Students.** By J. A. RANDALL, Instructor in Mechanics and Heat, Pratt Institute. xiv+331 pages, 5 $\frac{1}{4}$  by 8. 80 figures. Cloth, \$1.50 *net*.

**GAS POWER.** By C. F. HIRSHFELD, Professor of Power Engineering, Sibley College, Cornell University, and T. C. ULBRICHT, formerly Instructor, Department of Power Engineering, Cornell University. viii+198 pages, 5 $\frac{1}{4}$  by 8. 60 figures. Cloth, \$1.25 *net*.

**STEAM POWER.** By C. F. HIRSHFELD, Professor of Power Engineering, Sibley College, Cornell University, and T. C. ULBRICHT, formerly Instructor, Department of Power Engineering, Cornell University. (*Ready in Fall, 1915.*)

**HEAT AND LIGHT IN THE HOUSEHOLD.** By W. G. WHITMAN, State Normal School, Salem, Mass. (*In preparation.*)

## MECHANICS

**ELEMENTARY PRACTICAL MECHANICS.** By J. M. JAMESON, Girard College, formerly Pratt Institute. xii+321 pages, 5 by 7 $\frac{1}{4}$ . 212 figures. Cloth, \$1.50 *net*.

**MECHANICS FOR MACHINISTS.** By R. W. BURNHAM, Erasmus Hall High School, Brooklyn, Instructor in Evening Machine Work, Pratt Institute. (*In preparation.*)



## MATHEMATICS

**PRACTICAL MATHEMATICS.** By C. R. DOOLEY, Westinghouse Electric and Manufacturing Company, Pittsburgh. (*In preparation.*)

**A SHOP MATHEMATICS FOR MACHINISTS.** By R. W. BURNHAM, Instructor in Machine Work, Pratt Institute Evening School. 5 by 7. 175 figures. Cloth,

**PRACTICAL SHOP MECHANICS AND MATHEMATICS.**  
By JAMES F. JOHNSON, Superintendent of the State Trade School, Bridgeport, Conn. viii+130 pages, 5 by 7. 81 figures. Cloth, \$1.00 *net*.

**ARITHMETIC FOR CARPENTERS AND BUILDERS.** By R. BURDETTE DALE, Assistant Professor in charge of Vocational Courses in Engineering and Correspondence Instruction, Iowa State College. ix+231 pages, 5 by 7. 109 figures. Cloth, \$1.25 *net*.

## AGRICULTURE

**POULTRY.** By Professor J. C. GRAHAM, Massachusetts Agricultural College. (*In preparation.*)

**SOILS.** By Professor A. G. McCALL, Ohio State University. (*In preparation.*)

**AGRICULTURAL CHEMISTRY.** By Professor T. E. KEITT, Clemson Agricultural College. (*Ready September, 1915.*)

**INJURIOUS INSECTS.** By Dean E. D. SANDERSON and Professor L. M. PEAIRS, West Virginia University. (*Ready September, 1915.*)

**AGRICULTURAL DRAFTING.** By CHARLES B. HOWE, M.E. 46 pages, 8 by 10 $\frac{3}{4}$ . 45 figures, 22 plates. Cloth, \$1.25 *net*.

**STUDIES OF TREES.** By J. J. LEVISON, Forester, Park Department, Brooklyn, N. Y. x+253 pages, 5 $\frac{1}{4}$  by 8. 156 half-tone illustrations. Cloth, \$1.60 *net*.

**MARKET GARDENING.** By Professor F. L. YEAW, Oasis Farm & Orchard Company, Roswell, New Mexico. Formerly Professor of Market Gardening, Massachusetts Agricultural College. vi+120 pages, 5 by 7. 36 figures. Cloth, 75 cents *net*.

## FIELD AND LABORATORY MANUALS IN AGRICULTURE

**Studies of Trees: Their Diseases and Care.** By J. J. LEVISON, M.F., Lecturer on Ornamental and Shade Trees, Yale University Forest School, Forester to the Department of Parks, Brooklyn, N. Y. 20 pamphlets, 8 by 10½. \$1.00 *net*. Sold separately if desired. Price each 5, 10, or 15 cents according to size.

**Exercises in Farm Dairying.** By Professor C. LARSEN, Department of Dairy Husbandry, South Dakota State College. Loose leaf. 8 by 10½. 69 Exercises. Single Exercises two cents each. Complete, \$1.00 *net*.

**Exercises in Poultry Raising.** By Professor J. C. GRAHAM, Massachusetts Agricultural College. (*In preparation.*)

**Farm Crops and Soils.** By Professor A. G. McCALL, Department of Agronomy, Ohio State University. (*Ready September, 1915.*)

**Exercises in Agricultural Chemistry.** By Professor T. E. KEITT, Clemson Agricultural College. (*In preparation.*)

## THE LOOSE LEAF LABORATORY MANUAL

A series of carefully selected exercises to accompany the texts of the Series, covering every subject in which laboratory or field work may be given. Each exercise is complete in itself, and is printed separately. These will be sold by the single sheet as selected or where preferred will be bound in paper cover.

**Exercises in General Chemistry.** By CHARLES M. ALLEN, Head of Department of Chemistry, Pratt Institute. An introductory course in Applied Chemistry, covering a year's laboratory work on the acid-forming and metallic elements and compounds. 62 pages, 8 by 10½. 61 exercises.

Selected exercises as desired, to fit an ordinary binder, two cents each. Complete in paper cover, \$1.00 *net*.

**Exercises for the Applied Mechanics Laboratory.** By J. P. KOTTCAMP, M.E., Instructor in Steam and Strength of Materials, Pratt Institute. Steam; Strength of Materials; Gas Engines; and Hydraulics. 8 by 10½. 55 exercises, with numerous cuts and tables.

Selected exercises as desired, to fit an ordinary binder, two cents each. Complete in paper cover, \$1 *net*.

**Quantitative Chemical Analysis.** By CHARLES M. ALLEN, Head of Department of Chemistry, Pratt Institute. 12 pamphlets. 8 by 10½. Complete in paper cover, \$1.00 *net*. Single pamphlets furnished if desired. Price according to size.

## THE LOOSE LEAF LABORATORY MANUAL—Cont.

**Exercises in Industrial Chemistry.** By Dr. ALLEN ROGERS, Instructor in Qualitative Analysis, Pratt Institute. (*In preparation.*)

**Technical Chemical Analysis.** By R. H. H. AUNGST, Instructor in Technical Chemistry, Pratt Institute. 19 pamphlets. 8 by 10½. Complete, 85 cents *net*. Single pamphlets if desired, 5 cents each.

**Qualitative Chemical Analysis.** By C. E. BIVINS, Instructor in Qualitative Analysis, Pratt Institute. 11 pamphlets, supplemented by *Work Sheets* by which the student is taught equations and chemical processes. Complete with work sheets in paper cover, \$1.25 *net*. Work sheets one and two cents each. Pamphlets separately according to size.

**Elementary Electrical Testing.** By PROFESSOR V. KARAPETOFF, Cornell University, Ithaca, N. Y. 25 exercises, 50 cents *net*. Single exercises, two cents each.

**Exercises in Mechanics.** By J. M. JAMESON, Girard College; Formerly Pratt Institute. 52 exercises. Single exercises two cents each. Complete in paper cover, 85 cents *net*.

**Exercises in Heat.** By J. A. RANDALL, Instructor in Mechanics and Heat, Pratt Institute. 13 exercises, with numerous cuts and diagrams. Single exercises two cents *net* each.

**Exercises in Electricity, A. C. and D. C.** By W. H. TIMBIE, Head of Department of Applied Science, Wentworth Institute. 49 Exercises. Single exercises, two cents each. Complete in paper cover, 85 cents *net*.

### SHOP TEXTS

**MACHINE SHOP PRACTICE.** By W. J. KAUP, Special Representative, Crucible Steel Company of America. xii+199 pages, 5¼ by 8. 163 figures. Cloth, \$1.25 *net*.

**PATTERN MAKING.** By FREDERICK W. TURNER and DANIEL G. TOWN, Mechanic Arts High School, Boston. v+114 pages, 5 by 7. 88 figures. Cloth, \$1.00 *net*.

**TOOL MAKING.** By W. J. KAUP, Special Representative, Crucible Steel Company of America, and J. A. CHAMBERLAIN, Supervisor of Manual Training, Washington, D. C. (*In preparation.*)

**A SHOP MATHEMATICS FOR MACHINISTS.** By R. W. BURNHAM, Instructor in Machine Work, Pratt Institute Evening School. 5 by 7. 175 figures. Cloth,

## **PRACTICAL SHOP MECHANICS AND MATHEMATICS.**

By JAMES F. JOHNSON, Superintendent of the State Trade School, Bridgeport, Conn. viii + 130 pages, 5 by 7. 81 figures. Cloth, \$1.00 *net*.

## **DRAFTING AND DESIGN**

### **DECORATIVE DESIGN. A Text-Book of Practical Methods.**

By JOSEPH CUMMINGS CHASE, Instructor in Decorative Design at the College of the City of New York and at Cooper Union Woman's Art School. (*In press.*)

### **AGRICULTURAL DRAFTING.** By CHARLES B. HOWE, M.E.

viii + 63 pages, 8 by 10 $\frac{3}{4}$ . 45 figures, 26 plates. Cloth, \$1.25 *net*.

### **ARCHITECTURAL DRAFTING.** By A. B. GREENBERG, Stuy-

vesant Technical High School, New York, and CHARLES B. HOWE, Bushwick Evening High School, Brooklyn. viii + 110 pages, 8 by 10 $\frac{3}{4}$ . 53 figures, 12 plates. Cloth, \$1.50 *net*.

### **MECHANICAL DRAFTING.** By CHARLES B. HOWE, M.E.

Bushwick Evening High School, Brooklyn. (*In Press.*)

### **ENGINEERING DRAFTING.** By CHARLES B. HOWE, M.E.,

Bushwick Evening High School, Brooklyn, and SAMUEL J. BERARD, Sheffield Scientific School, Yale University.

### **THE LOOSE LEAF DRAWING MANUAL.** Reference and

Problem Sheets to accompany the texts of Agricultural and Architectural Drafting. These will be furnished singly as selected, and are designed to enable the instructor to adapt his instruction closely to the needs of his class. Price two cents each.













LIBRARY OF CONGRESS



0 003 063 472 A