



BVZO/4/1829

Digitized by the Internet Archive
in 2012 with funding from
Royal Botanic Garden Edinburgh

MEMOIRS
OF THE
CALEDONIAN
HORTICULTURAL SOCIETY.

VOLUME FOURTH.

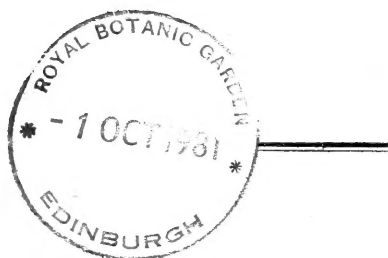

EDINBURGH:
MACLACHLAN & STEWART, EDINBURGH;
AND SIMPKIN & MARSHALL, LONDON.

MDCCCXXIX.

7/3

P. NEILL, PRINTER.

ADVERTISEMENT.

THE Committee for publishing the Transactions of THE CALEDONIAN HORTICULTURAL SOCIETY, are happy to be now able to present to its Members, and the Public, the Second Part of the Fourth Volume. This Part, or Half Volume, contains no fewer than *fifty-four* different communications, illustrated by Ten Engravings. Many of these Papers are written either by distinguished Amateur Horticulturists, or by Practical Gardeners of great experience. That every paper should be equally interesting, is not surely to be expected. But, while it is to be distinctly understood, that the respective Authors alone, and not the Society, are to be held responsible for the contents of the Papers; the Committee confidently trust that the publication will, as a whole, prove generally acceptable and useful to horticulturists.

Some of the communications, it will be remarked, are rather of an old date. This arose from circumstances beyond the controul of the Committee; particularly the long continued illness, and subsequent death, of one of their Secretaries Mr THOMAS DICKSON, in whose custody not a few of the MSS. happened to be placed.

The Committee already possess ample materials for another Part or Half Volume; and, in the course of it,

they hope to be able to overtake all communications, the publication of which is in arrear. Every thing, however, must depend on the sale of the Work indemnifying the expence of Paper, Printing, and Engraving. All Members are therefore earnestly requested to promote this object, by procuring their own copies without delay.

CONTENTS.

HISTORY OF THE SOCIETY.

	Page
LETTER from Lord SIDMOUTH to the Earl of HOPETOUN, intimating his MAJESTY'S becoming Patron of the So- ciety, - - - - -	1
Additional List of Honorary Members, - - -	2
List of Ordinary Members from June 1819 to September 1826, - - - - -	3-14
List of Corresponding Members from June 1819 to September 1826, - - - - -	14-18
Additional List of Foreign Members, - - -	19
Office-bearers for 1826, - - - - -	20
Detailed Account of Premiums awarded from 3d June 1819 to 11th July 1822, - - - - -	21-43
Address voted to the King on occasion of his visiting Scotland, - - - - -	44
Detailed Account of Premiums awarded from 5th Sep- tember 1822 to 26th October 1826, - - -	45-86
Warrant for a Royal Charter of Incorporation to the Society, - - - - -	87-93
Charta, Societatem in corpus corporatum erigens,	94-100

EXPERIMENTAL GARDEN.

Circular to the Members, and List of Shareholders,	101-109
First Report of the Garden Committee, 5th March 1825, and Ground-Plan of the Garden, - -	109-121
Second Report of the Garden Committee, 15th June 1826, - - - - -	122-130

MEMOIRS.

Account of a new Mode of Grafting Camellias, (with a Plate). By Professor DUNBAR, - - - - -	133
Remarks on the French Methods of Cultivating the Peach- tree. By Mr JOHN SMITH, - - - - -	138

On the Cultivation of certain Ornamental Plants in Flower-pots filled with Hypnum-mosses. By Mr JOHN STREET, Biel,	- - - - -	158
On the Economical Arrangement of Fruit-trees in a small Garden. By Mr DICK, Ballindean,	- - - - -	163
Description of an Economical Pit for preserving Vegetables and Salads during Winter, and raising Early Vegetables in the Spring, (with a Plate). By Mr STEWART, Valleyfield,	- - - - -	173
On the utility of employing Grass Sward in forwarding Early Crops of certain Vegetables. By Mr BISSET, Methven Castle	- - - - -	180
Observations regarding the Management of Oak Coppice-Woods, &c. (with a Plate). By Mr HOSIE, Lynedoch,	- - - - -	189
Account of an Improved Mode of Ventilating Hot-Houses. By Mr TWEEDIE,	- - - - -	200
Queries relative to the Sowing, instead of Planting, of Forest Trees,	- - - - -	205
Account of a simple and effectual method of destroying the Scaly Insect. By Mr BEATTIE, Scone,	- - - - -	209
Remarks on the Locust-tree recommended by Mr Cobbet, &c. By Mr THOMAS BLAIKIE,	- - - - -	212
On scraping off the Old Bark of Fruit-trees. By Mr T. THOMSON,	- - - - -	220
On the raising of Seedling Ranunculuses, &c. By Mr JOHN WATERSTON, Paisley,	- - - - -	227
Account of a Method of cultivating the Grape-Vine, (with a Plate). By Mr NINIAN NIVEN,	- - - - -	234
On Mulching and Watering Fruit-tree Borders. By Mr SMITH, Hopetoun,	- - - - -	244
Notice of some Forest and Ornamental Trees which deserve the attention of Scottish cultivators. By G. L. MEASON, Esq.	- - - - -	251
Notice of the hardy Fruits of Upper Canada. By Mr T. BLAIR,	- - - - -	254
Hints on Increasing the Warmth of Garden-Walls, &c. By Mr JOHN HENDERSON, Brechin,	- - - - -	258

CONTENTS

OF

PART II.

	Page
On the raising of Mushrooms, and on the forcing of Rhubarb Stalks in the open air. By Mr JAMES STUART,	273
On the ripening of Fruit by Artificial Heat, after being taken from the Tree. By Mr JAMES HOWISON, - - -	279
On the raising of Mushrooms during the Winter Season. By Mr A. KELLY, - - - - -	283
On destroying Slugs (<i>Limax cinereus</i> and <i>agrestis</i>). By Mr ARCHIBALD GORRIE, - - - - -	289
Account of a New Mode of Planting and Cultivating Fruit Trees, with a view to prevent Canker, and to procure well-ripened Fruit. By Mr ARCHIBALD REID, -	292
Observations on the Culture of Onions. By the late Dr A. DUNCAN, - - - - -	305
Remarks, 1. On the Propagating of certain Plants by Cuttings; 2. On enuring of certain Plants to our Climate; 3. On the Grafting of Orange Trees. By Mr JOHN MACHRAY, - - - - -	310
Description of an Improved Flower-pot, with an interior Moveable Bottom. By JAMES HOWISON, Esq. -	317
Remarks on some Species of Edible Gourds, and on the Modes of Dressing them for Table. By Mr DANIEL CRICHTON, - - - - -	322
On the Keeping of Apples. By Mr WILLIAM OGILVIE,	326
On preparing a Light Garden-Soil for Carrots and for Onions. By Mr PETER CAMPBELL, - - - - -	333
On the Upright Training of Garden Rose-bushes, and of the <i>Cydonia Japonica</i> . By Mr JOHN DICK, -	337
Account of Oiled Paper-Frames for protecting the Blossom of Wall-Trees. By Mr ALEXANDER SMITH, -	342

	Page
Notice of an Improved Mode of Glazing Hot-house Sashes. By JOHN ROBISON, Esq. (Plate VI.) - - -	348
Account of Steam-Pits for the Culture of Melons, at Rock- ville, in East Lothian. By Mr PETER DEWAR, (Plate VII.)	350
Notice regarding the Ionian Melon and the Malta Melon. By Mr DANIEL CRICHTON, - - - - -	354
Notice regarding the Cause of Canker, the Natural History of the Red Spider, &c. By Mr WILLIAM BLAIR,	358
Notice regarding Indian Saws. By JOHN ROBISON, Esq. (Plate VIII.) - - - - -	362
On the Utility of gathering Unripe Tomatoes, and maturing them on Shelves in Hot-houses. By Mr W. M ^c MUR- TRIE, - - - - -	364
Hints and Notices connected with Horticulture. By JOHN MURRAY, Esq. - - - - -	370
On the Gooseberry Caterpillars, and the application of Heat for their destruction. By ROBERT THOM, Esq. (Plate VIII.)	378
On the Cultivation of Onions ; on Preparing Ground for Car- rots ; and on Destroying the Gooseberry Caterpillar. By Mr JOHN WALLACE, - - - - -	391
Notice regarding the Scarificator figured in Plate VIII. fig. 5. By JOHN GORDON, Esq. - - - - -	395
Notice of an Improved Garden Hammer. By Mr JOHN DICK. (Plate VIII.) - - - - -	398
Description of, and Directions for using, a New Preservative Frame for saving Wall Fruit from being destroyed by Wasps, Blue-flies, or Birds, when it is ripe ; and also for protecting the Blossom in spring from frost, and ensuring a crop of Fruit. By Mr JOHN DICK, (Plate IX.)	400
On the Cultivation of Strawberries. By Mr JOHN MIDDLE- TON, - - - - -	408
On Saving the Seeds of some Culinary Vegetables and Orna- mental Flowers in Scotland. By ALEXANDER HEN- DERSON, Esq. - - - - -	416
On Forcing of Sea-Cale, and on the Culture of Sicilian Broc- coli, &c. By EDMUND CARTWRIGHT, Esq. - - -	418
On Destroying Caterpillars. By Mr ALEXANDER WITHER- SPOON, - - - - -	421

	Page
Hints on Transplanting of Onions ; on Canker in Fruit-Trees ; on Scottish Pears, &c. By Colonel SPENS, -	425
On the Formation of a Gardener's Library. By Mr JAMES SMITH, - - - - -	441
On the Cultivation of Peaches and Nectarines on Flued Walls ; on Screening the Blossom of Wall-Trees by means of Nets and Ferns ; on Saving Peas and Beans from the attacks of Mice ; and on Destroying these Vermin. By Mr WILLIAM IRVING, - - - - -	446
Hints on the Management of the Grape-Vine, particularly in Peach-Houses ; and on Propagating Vines by Layers and Cuttings. By Mr JOHN MARTIN, - - - - -	455
Notice of a Hawthorn Hedge, damaged by <i>Æcidium lacera-</i> <i>tum</i> . By Mr WILLIAM DON, - - - - -	459
On the Curl in Potato, and on the Transplanting of Onions. By Mr PETER LOWE, - - - - -	462
Some Account of the Fruits grown in Gourdiehill Orchard, Carse of Gowrie, with Remarks. By PATRICK MA- THEW, Esq. - - - - -	467
Account of a Collection of Gooseberry Bushes contained within an inclosure in the Nurseries at Perth. By AR- CHIBALD TURNBULL, Esq. - - - - -	481
Account of the mode of making various Liqueurs, &c. By Mr LEWIS PEDERANA, - - - - -	486
Account of Fruit-Trees trained to a Wall inclined to the Horizon, at an angle of about 10°, in a Garden at Por- tobello. By WILLIAM CREELMAN, Esq. (Plate X.)	493
Postscript to Dr WILLIAM HOWISON's Paper on the Culi- nary Vegetables of the Russian Empire. By Dr HOWI- SON, - - - - -	497
On the kinds of Grape-vine best suited for Hot-walls in Scot- land. By Mr GEORGE SHIELLS, - - - - -	500
On the Use of Hop-Tops as a Culinary Vegetable ; and an Account of different Modes of Dressing Gourds for the Table. By Mr LEWIS PEDERANA, - - - - -	504
On Heating Hot-Houses by Steam. By the Rev. JAMES ARMITAGE RHODES. (Plate XI.) - - - - -	511

	Page
Account of a mode of training Vines on the outside of the alternate Sashes of a Hot-House, by which means excellent Grapes were produced. By Mr JAMES MACDONALD. (Plates XII. and XIII.) - - - - -	520
Of the Disease in Turnips called Anbury, or Fingers and Toes, - - - - -	529
An Account of some Seedling Apples and Plums which have been raised at Coul, in Ross-shire, - - - - -	554
On Canker in Fruit-Trees depending on bad Subsoil. By Mr PETER CAMPBELL, - - - - -	559
On the Germination of Seeds and subsequent Vegetation. By JOHN MURRAY, Esq. - - - - -	564
Account of the Mode of Culture adopted at Cunnoquhie, in raising Pine-Apples and Melons, in a Pit heated by Steam; with a Description of the Pit and Steam Apparatus. By Mr ALEXANDER SMITH, - - - - -	570
Account of a Glazed House, adapted for the Culture of Peach-Trees, Grape-Vines, and Ornamental Plants. By Mr R. F. D. LIVINGSTON, - - - - -	576
Account of a Mode of producing a steady and uniform Bottom-Heat in Pine-apple or Melon Pits, or in Stoves for Exotic Plants, by means of Steam introduced into a close chamber filled with water-worn stones. By Mr JOHN HAY. (Plates XIV. and XV.) - - - - -	582

TO THE BINDER.

In binding Parts I. and II. into One Volume, the Binder is requested to preserve the Contents of Part I. and prefix it to the Volume with the Contents of Part II.

MEMOIRS
OF THE
CALEDONIAN
HORTICULTURAL SOCIETY.

PATRON,
The King.

LETTER from Lord SIDMOUTH to the late EARL OF HOPETOUN.

MY LORD,

Whitehall, 14th August 1820.

I HAVE had the honour to receive, and to lay before THE KING, your Lordship's letter of the 22d of last month, in which you state, by the desire of the CALEDONIAN HORTICULTURAL SOCIETY, of which your Lordship is President, that it is the Society's earnest wish that HIS MAJESTY would be graciously pleased to honour the Society by becoming its Patron; and I have great satisfaction in acquainting your Lordship, that HIS MAJESTY has most condescendingly consented to become the PATRON of the CALEDONIAN HORTICULTURAL SOCIETY, in compliance with its wishes expressed through your Lordship, as the President of the Society.

I have the honour to be,

MY LORD,

Your Lordship's

Most obedient humble Servant,

SIDMOUTH.

EARL OF HOPETOUN,

&c. &c.

Hopetoun House, Edinburgh.

HONORARY MEMBERS.

September 7. 1820.

HIS ROYAL HIGHNESS FREDERICK, DUKE OF YORK.

HIS ROYAL HIGHNESS WILLIAM HENRY, DUKE OF CLARENCE.

Letters of acceptance from Sir Herbert Taylor on the part of the Duke of York, and from John Barton, Esq. on the part of the Duke of Clarence, were laid before the Society on the above date.

LIST OF MEMBERS

ELECTED SINCE 4TH MARCH 1819,

(Continued from Vol. III. p. 26.)

HONORARY.

June 3. 1819.

The Right Hon. the Earl of Bridgewater.

March 4. 1820.

The Right Hon. Lord Erskine.

June 1. 1820.

The Right Hon. Lord Montagu, Ditton Park.

December 5. 1822.

The Right Hon. William Pitt, Lord Amherst, Governor-General of India.

Robert Barclay, Esq. of Buryhill, Dorking, Surrey.

March 13. 1823.

The Right Hon. Robert Peel, His Majesty's Principal Secretary of State for the Home Department.

September 2. 1824.

Colonel Hardwick senior, Hon. East India Company's Service.

December 2. 1824.

The Right Hon. the Earl of Dalhousie, Dalhousie Castle.

December 2. 1825.

The Right Hon. Lord Gifford, London.

The Right Hon. Sir Samuel Shepherd, Lord Chief-Baron
of Scotland.



ORDINARY.

June 3. 1819.

His Grace Alexander, Duke of Gordon, Gordon Castle,
Fochabers.

Dr David Brewster, Sec. R. S. Ed. Allerly, Melrose.

The Rev. Dr David Scott, Corstorphine.

Robert N. Campbell, Esq. of Kailzie.

Thomas Duncan, Esq. writer.

Robert Thomson, Esq. Gilmour Place.

Captain Andrew Thomson, R. N. Meadow Place.

September 2. 1819.

The Very Rev. Dr George Husband Baird, Principal of the
University of Edinburgh, Forneth.

Robert Gordon, Esq. Newington.

James Robinson Scott, Esq. F. L. S.

James Moncrieff, Esq. advocate.

George Moncrieff, Esq.

John Balfour, Esq. Hailes.

John Haig, Esq. Bonnington.

Thomas Buchanan, Esq. Pilrig Street.

William Gardner, Esq. W. S.

John Lindsay Donaldson, Esq. Edinburgh.
 John Smith, Esq. W. S.
 Mr John Tod, Goshan, Prestonpans.
 John Barclay Shiell, Esq. Edinburgh.
 Dr George Wilde, Edinburgh.
 James Johnstone, Esq. Edinburgh.
 George William Boyd, Esq. W. S.
 Mr James Sinclair, seedsman, Edinburgh.
 Charles Crossland Hay, Esq. Roslin Castle.
 Robert Purdie, Esq. Prince's Street.
 William Purves, Esq. merchant, Edinburgh.
 Dr William Graham, Edinburgh.

December 2. 1819.

Robert Andrew Wauch, Esq. of Foxhall.
 John Buchan Brodie, Esq. W. S.
 Alexander Scot, Esq. of Trinity, W. S.
 Alexander Macleod, Esq. of Muiravonside.
 William Berwick, Esq. Canongate.
 Robert Davidson, Esq. of Ravelrig.
 James Dallas, Esq. merchant, Edinburgh.
 The Rev. Henry Wastell, Newborough, Northumberland.
 John Barker, Esq. surgeon, Edinburgh.
 Archibald Duncan, Esq. writer, Edinburgh.
 William P. Williamson, Esq. merchant, Leith.

March 4. 1820.

The Right Hon. George, Earl of Dunmore, Dunmore Park.
 John Anderson, Esq. Bruntsfield Links.
 James Macbrair, Esq. of Tweedhill.
 Edward Robertson, Esq. St John's Hill.
 Dr Robert Graham, Regius Professor of Botany in the University of Edinburgh.
 John Gray, Esq. Deputy-Collector of Stamp-duties, Edin.

Robert Buchan, Esq. painter, George Street.
 William Farquharson, Esq. of Monaltree.
 Robert Thom, Esq. Rothesay.
 William Tullis, Esq. Roxburgh Place.
 John Mackirday, Esq. of Birkwood.
 David Ramsay, Esq. writer to the Signet.
 William Grant, Esq. younger of Congalton.

June 1. 1820.

James Hunter, Esq. of Thurston.
 M. S. Nicolson, Esq. of Carnock.
 Dr John Aitken, surgeon, Edinburgh.
 David Clyne, Esq. S. S. C.
 Walter Graham, Esq. Merchiston Lodge.
 William Spalding, Esq. writer, Edinburgh.
 John Ritchie, Esq. writer, Edinburgh.

September 7. 1820.

His Grace John, Duke of Atholl, Atholl House, Dunkeld.
 Dr William Dyce, Professor of Midwifery, Aberdeen.
 Thomas Cranstoun, Esq. of Dewar.
 John Zeigler, Esq. Edinburgh.
 William Vertue, Esq. Edinburgh.
 John Henry Wishart, Esq. surgeon, Edinburgh.
 Dr Robertson Barclay of Caville, Fifeshire.

December 7. 1820.

Sir George Clerk, Bart. M. P. Penicuik.
 John Young, Esq. surgeon, Edinburgh.
 John Deuchar, Esq. Lecturer on Chemistry, Edinburgh.
 Peter Cathie, Esq. Fisherrow.
 Thomas Miller, Esq. younger of Glenlee.
 James Scott, Esq. accountant, Edinburgh.
 James Bartram, Esq. Pleasance, Edinburgh.
 William Turnbull junior, Esq. merchant, Edinburgh.

Alexander Stevenson, Esq. S. S. C.
 Mr Francis Davidson, confectioner, Edinburgh.
 Robert Kaye Greville, Esq. LL.D. Edinburgh.
 Robert Russell, Esq. Easter Invergordon-House.
 J. F. Clark, Esq. surgeon, Juniper-House.

March 8. 1821.

George Robertson, Esq. of the Register-Office, Edinburgh.
 William Clark, Esq. writer to the Signet, Edinburgh.
 John Drummond, Esq. manufacturer, Edinburgh.
 Mr John Pettet, Saughton Hall.

June 7. 1821.

Daniel Vere, Esq. of Stonebyres.
 The Rev. Robert Clarke of Hexham.
 John Kerr, Esq. of Kerfield.
 James Aitken, Esq. merchant, Leith.
 Henry Raeburn, Esq. St Bernard's.
 Andrew Bogle, Esq. cashier, Royal Bank.
 John Stirling, Esq. accountant, Royal Bank.

September 6. 1821.

The Hon. General Lesslie Cuming.
 Major Lee Harvey of Castle-Semple.
 David Anderson, Esq. of Moredun.
 George Robertson Scott, Esq. of Benholm.
 J. W. Turner, Esq. Professor of Surgery to the Royal College of Surgeons.
 Francis Wilson, Esq. W. S. Edinburgh.
 Peter Smellie, Esq. younger of Addiewell.
 Henry Raeburn junior, Esq. of St Bernard's.
 Alexander White, Esq. merchant, Leith.
 John Stark, Esq. printer, Edinburgh.
 Peter Macdowall, Esq. accountant, Edinburgh.
 John Morison, Esq. W. S. Edinburgh.

Samuel Wordsworth, Esq. Nottingham Place.
 Dr William Macdonald of Ballishare.
 John Thorburn, Esq. writer, Edinburgh.
 William Millar, Esq. Newington.
 Walter Marshall, Esq. Edinburgh.
 John Thorburn, Esq. Leith.
 William H. Playfair, Esq. architect, Edinburgh.
 Robert S. Ainslie, Esq. Inveresk.
 Charles Fleming, Esq. 16. Albany Street, Edinburgh.
 George Brown, Esq. writer, Edinburgh.
 Thomas Campbell, Esq. Argyll Square, Edinburgh.
 Robert Paul, Esq. accountant, Edinburgh.
 William Mitchell, Esq. Parson's Green, Edinburgh.
 Mr Charles Buchanan, gardener, Hailes, East Lothian.

December 6. 1821.

The Right Hon. the Earl of Leven and Melville, Melville House:

Leonard Horner, Esq. Edinburgh.
 Alexander Wight, Esq. banker.
 John Campbell, Esq. of Carbrook.
 Robert Miller, Esq. bookseller, Edinburgh.
 William Hall, Esq. wine-merchant, Edinburgh.
 Charles S. Macalister, Esq. of Kennox.
 Hart Anderson, Esq. merchant, Edinburgh.
 William Dennistoun, Esq. of Oakmount.
 William Bonar, Esq. banker, Edinburgh.
 John Young, Esq. George Street, Edinburgh.
 Charles Shaw, Esq. Merchant Court, Edinburgh.
 Mr John Craig, seed-agent, Leith.
 Mr Robert Turnbull, seedsman, Edinburgh.

March 14. 1822.

Thomas Allan, Esq. of Lauriston Castle.
 Claud Russell, Esq. accountant, Edinburgh.

North Dalrymple, Esq. Campsie House, Musselburgh.

The Rev. Edward Craig, Edinburgh.

Dr John Mackintosh, Edinburgh.

Andrew Sievwright, Esq. Gayfield Square.

Charles Lawson, Esq. nurseryman, Edinburgh.

June 13. 1822.

The Right Hon. Archibald, Earl of Cassilis, Culzean Castle.

The Rev. Andrew Brown, D. D. Professor of Rhetoric and
Belles Lettres in the University of Edinburgh.

Dr James Buchan, President of the Royal College of Physi-
cians of Edinburgh. .

William Currie, Esq. of Linthill.

Andrew Gibson, Esq. Dean Park, Edinburgh.

September 5. 1822.

A. Murray Bartram, Esq. of Templebar, Peebles.

William Lamont, Esq. of Knockdow.

William Cuninghame Walker, Esq. of Dunnybank.

James Jackson, Esq. Edinburgh.

John Steedman, Esq. land-surveyor.

Thomas Butler, Esq. druggist, Prince's Street.

Hugh Austin, Esq. nurseryman, Glasgow.

Mr A. Haig, baker, North College Street.

Mr A. Galloway, wine-merchant, High Street.

Mr J. Brash, secretary North British Fire-Office.

December 5. 1822.

John Tod, Esq. of Kirkhill, W. S.

William Reid, Esq. bookseller, Leith.

Robert More, Esq. Underwood.

Eagle Henderson, Esq. younger of Press.

William Jackson Hooker, Esq. LL.D. Professor of Botany
in the University of Glasgow.

Samuel Aitken, Esq. bookseller, Edinburgh.

March 13. 1823.

William Hatelie, Esq. writer, Dewar Place.

F. Lindsay Carnegie, Esq. of Kinblythmont.

Alexander Fleming, Esq. W. S. Castle Street.

James Wemyss, Esq. Hanover Street.

June 12. 1823.

The Hon. Lord Succoth, Park Place.

A. J. Hamilton, Esq. younger of Dalzell.

John Hay Mackenzie, Esq. of Newhall, Haddington.

Andrew Snody, Esq. S. S. C. Leith Walk.

Colin Macnab, Esq. Great King Street.

David Freer, Esq. W. S.

James Johnstone, Esq. of Alva.

September 4. 1823.

The Hon. Colonel John Ramsay, Kelly House, Arbroath.

Colonel R. W. Duff of Fetteresso, Stonehaven.

Sir Thomas Gibson Carmichael of Skirling, Bart.

Lieut. James Lamont, R. N.

David Blaikie, Esq. W. S. Edinburgh.

Robert Brown, Esq. W. S. Edinburgh.

Adam Fairholm, Esq. of Chapel.

Graham Mercer, Esq. of Mavisbank.

Edward Gilchrist, Esq. Edinburgh.

Charles Wilson, Esq. solicitor-at-law, Edinburgh.

John Hogg, Esq. City Chambers, Edinburgh.

Alexander Stevenson, Esq. W. S.

John Rae, Esq. Newington.

Alexander Craig, Esq. surgeon, Edinburgh.

December 4. 1823.

Sir Alexander Keith of Ravelstone.

Admiral Sir Charles Philip Durham, K. C. B. of Fordeſ,
Fifeſhire.

Rev. Dr John Inglis.

Robert Mitchell, Eſq.

William Home Lizars, Eſq. James's Square, Edinburgh.

Alexander Hill, Eſq. W. S. Edinburgh.

Mark Sprott, Eſq. of Garnkirk.

John Crawford, Eſq. Newington.

J. R. Skinner, Eſq. W. S. Edinburgh.

Mr George Archibald, ſeedsman, Edinburgh.

Mr David Macgibbon, Broughton Street, Edinburgh.

March 11. 1824.

Sir Walter Scott, Bart. of Abbotsford.

John Barclay, M. D. Argyll Square, Edinburgh.

Charles Oliphant, Eſq. W. S. Caſtle Street, Edinburgh.

George Dunlop, Eſq. W. S. Beechwood.

William Laidlaw, Eſq. ſurgeon, Broughton Place,

David Jardine, Eſq. Canongate.

Claud Muirhead, Eſq. Heriot Row.

Robert Strong junior, Eſq. Leith.

James Johnſtone, Eſq. younger of Alva.

June 10. 1824.

Dr W. P. Alion, Conjunct Profeſſor of the Inſtitutes of Me-
dicine in the University of Edinburgh.

John Wilson, Eſq. Profeſſor of Moral Philoſophy in the
University of Edinburgh.

George Yule, Eſq. Broughton Park.

Joſeph Grant, Eſq. W. S. Argyll Square.

Macduff Rhind, Eſq. Marine Cottage, Pirniefield.

William Clerk, Eſq. advocate.

James Douglas, Eſq. Commercial Bank, Edinburgh.

September 2. 1824.—(N. B. Members elected at this meeting, and subsequently, pay an admission-fee of Two Guineas, and Two Guineas annually, one to the Society and another to the Garden; or compound for the former by a payment of Ten Guineas to the Society, and for the latter by purchasing a transferable share in the Garden.)

George Ballingall, Esq. Professor of Military Surgery in the University of Edinburgh.

Robert Brysson, Esq. South Bridge, Edinburgh.

Aitken Megget, Esq. Edinburgh.

December 2. 1824.

Sir William Jardine, Bart. of Applegirth.

Andrew Rutherford, Esq. advocate.

James Keay of Snaigo, Esq. advocate.

Captain Brown of Prinlaws.

Dr John Macwhirter, physician, Edinburgh.

Patrick Dudgeon, Esq. of East Craig,

William Allan, Esq. of Glen.

Walter Richard jun. Esq. Stamp-Office, Edinburgh.

Robert Falkner, Esq. wine-merchant, Edinburgh.

Charles Thomson, Esq. wine-merchant, Edinburgh.

September 1. 1825. (First Meeting held under the Royal Charter.)

The Right Hon. James, Earl of Lauderdale, Dunbar House.

Sir Thomas Dick Lauder, Bart. of Grange and Fountainhall.

Walter Campbell, Esq. of Isla, M. P.

James Balfour, Esq. of Whittingham.

John Richardson, Esq. of Pitfour.

William Marshall, Esq. jeweller, Edinburgh.

Dr Samuel Hibbert, Wharton Place.

William Keith, Esq. accountant.

John Brown, Esq. Graham Street.

John Cross, Esq. Gilmour Street.

Captain James Hay, R. N. of Belton by Dunbar.

Daniel Fisher, Esq. writer, Edinburgh.
 Dr Peter Smith, of Dunesk, Lasswade.
 John Broster, Esq. of Broche Hall, Chester.
 Andrew Moffat Wellwood, Esq. of Garvock, Dunfermline.
 George Houy, Esq. Courant Office, Edinburgh.
 William Oliphant, Esq. bookseller, Edinburgh.
 Sir James M. Riddell of Ardnamurchan, Bart.
 James Mackay, Esq. jeweller, Edinburgh.
 William Pattison, Esq. junior, merchant.
 John Hunter, Esq. Pitt Street.
 Mr John Reid junior, Rose Bank.
 John Robison, Esq. Coates Crescent.
 David Monro Binning, Esq. of Argatty.
 John Tait, Esq. younger of Pirn, W. S.
 W. D. Gillon, Esq. of Wallhouse
 The Hon. Lord Meadowbank, Meadowbank, Midlothian.
 John Henderson, Esq. W. S. Edinburgh.
 James Cockburn, Esq. Brighton Place, Portobello.
 James Boog, Esq. Portobello.
 C. S. Menteith, Esq. younger of Closeburn.
 Thomas Boulton Parkins, Esq. Newland, Gloucestershire.
 John Cuninghame, Esq. of Duloch, advocate.
 Count Mercer de Flahault, Tulliallan House, Kincardine.
 James Burnside, Esq. W. S. Edinburgh.
 David Mackinlay, Esq. W. S. Edinburgh.
 Charles Hitchiner, Esq. Stobs Mills.
 William Home, Esq. Pitt Street, Edinburgh.

December 1, 1825,

The Right Hon. Charles, Lord Kinnaird, Rossie Priory.
 Sir Thomas Trowbridge, Bart. Rockville, Haddington.
 Sir John Connell, Knight, Judge-Admiral of Scotland.
 Thomas Hardy, Esq. surgeon, Duke Street.
 John Henderson, Esq. Exchequer-Office.

Andrew Spalding, Esq. writer, East Broughton Place.
 John Blackwood, Esq. Claremont Crescent.
 John Stenhouse, Esq. St Andrew Street.
 Robert Ritchie, Esq. India Street.
 The Very Rev. Principal Robert Haldane of St Mary's Col-
 lege, St Andrew's.
 Alexander Smith, Esq. of Inverarderan.
 Alexander Ross, Esq. merchant, Salisbury Road.
 James Anderson, Esq. Depute-clerk of Justiciary, Elm Row.
 Alexander Stewart, Esq. Saxe-Cobourg Place.
 Richard Alexander, Esq. wine-merchant, Edinburgh.
 Robert Hamilton, Esq. Scotland Street.
 Jacob Dixon junior, Esq. Dunbarton.

March 2. 1826.

Thomas Blackwood, Esq. West Newington Place.
 William Blackwood, Esq. Salisbury Road.
 Captain Andrew Barclay, Portobello.
 Dr Richard Maddock Hawley, Maryfield.
 Alexander Berwick, Esq. St John Street.
 Mathew Walker, Esq. Edinburgh.
 Robert Ramsay, Esq. Charlotte Square.
 The Rev. Thomas Brown, Dalkeith.

June 1. 1826.

Robert Reid, Esq. architect, Charlotte Square.
 Andrew Watson, Esq. W. S. Edinburgh.
 Thomas Ferguson, Esq. W. S. Edinburgh.
 The Rev. Edward Ramsay, Darnaway Street.
 Thomas Duncan, Esq. of Grenada, Drummond Place.

September 7. 1826.

The Hon. Baron Clerk Rattray.
 The Hon. Baron Sir Patrick Murray, Bart. of Ochtertyre.
 The Right Rev. Bishop Sandford.

Henry Monteith, Esq. M. P. Carstairs, Lanark.
 Henry Duncan, Esq. Comely Green.
 Thomas Rymer, Esq. writer, Edinburgh.
 Alexander Kettle, Esq. W. S. Edinburgh.
 James M. Melville, Esq. W. S. Edinburgh.
 Thomas Sprott, Esq. W. S. Edinburgh.
 George Joseph Bell, Esq. Professor of Scots Law in the University of Edinburgh.
 Miles A. Fletcher, Esq. advocate, Edinburgh.
 Thomas Maitland, Esq. younger of Dundrennan.
 Mr Thomas Cleghorn, seedsman, Edinburgh.
 George Watt, Esq. surgeon, Drummond Place.
 Alexander Robertson, Esq. W. S. Castle Street.
 Mark Sprott, Esq. of Riddel.
 John Sprott, Esq. Picardy Place.
 James Dunlop, Esq. W. S. Howe Street.
 W. H. Millar, Esq. of Craigentiny near Edinburgh.



CORRESPONDING.

June 3. 1819.

William Bridgewater Page, Esq. nurseryman, Southampton.
 Mr William Fowlie, gardener to Thomas Freeman Heathcote, Esq. M. P. Embley near Runsey, Hants.

December 2. 1819.

Mr Ninian Lindsay, gardener to the Hon. Lord Hermand.
 John Wood, gardener and land-steward at Scarron near Newry, Ireland.
 Robert Loudon, gardener to Henry Monteith, Esq. of Carstairs.
 George Mill, gardener to Charles Stirling, Esq. of Cadder.

- Mr Daniel Macnab, gardener to His Grace the Duke of Argyll, Inverary.
- William Brown, gardener to Mr Alexander of Southbar.
- Donald Lindsay, gardener to Sir James Colquhoun, Bart. of Luss, Rosedoe.
- John Veitch, gardener to George Robinson senior, Esq. Greenock.
- Adam Melrose, gardener to Sir Michael Shaw Stewart, Bart. of Ardgowan.
- Robert Reid, gardener to T. F. Kennedy, Esq. of Dalquharson.
- Archibald Stewart, gardener to the Most Noble the Marquis of Londonderry, Mount Stewart.
- John Douglas, gardener to H. S. Stewart, Esq. of Physgil.
- William Cruickshanks, gardener to the Right Hon. Lady Blantyre, Lennoxlove.
- Thomas Kelly, gardener to Sir Robert Abercrombie Bart. Airthrie.

March 4. 1820.

- Mr George Low, gardener to William Farquharson, Esq. Monaltree.
- John Cullen, gardener to R. Cuninghame, Esq. Cloncaird.
- George Foster, gardener to the Hon. Sir A. Hope of Luffness, Bart.
- Lachlan Campbell, gardener, Northbar, Glasgow.

June 1. 1820.

- Mr William Pearson, gardener to the Right Hon. the Earl of Hopetoun, Ormiston Hall.
- Hugh Ross, gardener to Lady Dundas of Beechwood.
- John Christie, gardener to Ebenezer Gilchrist, Esq. of Sunnyside.

Mr William Laidlaw, gardener to S. Anderson, Esq. of Moredun.

Charles Mackintosh, gardener to the Right Hon. the Earl of Breadalbane, Taymouth Castle.

James Muir, gardener to William Hay, Esq. Bonnington.

John Kay, gardener to Mr Stuart, Windlestrawlee.

Adam Birrie, gardener to John Cheyne, Esq. of Bonnington Brae.

September 7. 1820.

Mr Andrew Pace, gardener to Sir John Dalrymple, Bart. Oxenford Castle.

James Webster, Sir George Cornwall's, Bart. Marlow Court, near Hereford.

Alexander Forbes, gardener to the Hon. F. G. Howard, Levens, near Milnthorp, Westmoreland.

David White, gardener to General Balfour, Whitehill, by Lasswade.

William Melrose, gardener to the Right Hon. the Earl of Morton, Dalmahoy.

James Hislop, gardener to the Hon. Lord Meadowbank, Meadowbank.

Archibald Kay, gardener to the Hon. Mrs Erskine, Ammondell.

December 7. 1820.

Mr John C. Monro, nurseryman, Evanton, Navar.

Thomas Henderson, gardener to the Hon. General Duff, Delgaty Castle.

James Walker, nurseryman, Aberdeen.

John Reynolds, gardener to John Beddulph, Esq. Ledbury, Herefordshire.

Hugh Ramsay, gardener to James Smith, Esq. Craighend, Strathblane.

Mr Daniel Cunninghame, gardener to Sir Ilay Campbell,
Bart. Garscube.

Alexander Coutts, gardener to James Davidson, Esq.
Colzium.

Thomas Waldron, gardener to the Right Hon. the Earl
of Cassilis, Culzean Castle, Maybole.

William Moffat, gardener to Peter Johnston, Esq. Carn-
salloch.

June 7. 1821.

The Rev. J. M. Robertson, minister of Livingstone.

December 6. 1821.

Dr John Hunter, Professor of Humanity, St Andrew's.

March 14. 1822.

Mr Thomas Johnston, gardener at St Leonard's, St An-
drew's.

Duncan Macnaughton, gardener to Miss Moncrieff of Dal-
honsie near Comrie.

June 13. 1822.

Hercules Scott, Esq. Professor of Moral Philosophy in the
University and King's College, Aberdeen.

Mr James Webster, gardener to John H. Maxwell, Esq. of
Munches.

December 5. 1822.

Mr John Callender, gardener to the Right Hon. Lord Douglas,
Bothwell Castle.

June 12. 1823.

Mr Charles Doig, gardener to W. Inglis, Esq. of Middleton.

Thomas Berry, gardener to P. G. Skene, Esq. Halyards.

September 4. 1823.

Mr James Donaldson, gardener to Alexander Pringle, Esq. of Yair.

Malcolm Carmichael, gardener to J. J. Hope Johnstone, Esq. of Raehills.

December 4. 1823.

Dr Francis George Probart, Lincolnshire.

March 11. 1824.

John Dunlop, Esq. of Whitemuirhall.

September 2. 1824.

Dr B. Macleod, Hon. East India Company's Service.

September 1. 1825.

Mr Thomas Drummond of Forfar, now on the North-west American Expedition.

John Ross, gardener to James Dundas, Esq. of Dundas Castle.

March 2. 1826.

George Cumming Scott, Esq. Master of the Anglo-Mexican Mint at Guanaxuato.

Mr Joseph Miller, gardener to Count Flahault, Tulliallan.

June 2. 1826.

Mr David Thomson, gardener to General Balfour of Balbirnie, Fifeshire.

September 7. 1826.

Mr James Barnet, Superintendant of the Experimental Garden.

Mr Thomas Stewart, gardener to Lieutenant-General Durham at Largo.

FOREIGN.

December 2. 1819.

Mr A. F. Louis Schell, gardener to His Royal Highness the
Grand Duke of Saxe-Weimar.

March 8. 1821.

Dr L. T. Frederick Colladon of Geneva.

September 1. 1825.

The Chevalier Masclet, French Consul for Scotland.

OFFICE-BEARERS, 1826.

President.

THE RIGHT HON. GEORGE, EARL OF DUNMORE.

Vice-Presidents.

Dr DUNCAN sen. (*Permanent.*) Sir HENRY JARDINE, Knight.
Sir JOHN HAY, Bart. Lord Provost TROTTER.

Mr P. NEILL, *Secretary.* Mr A. DICKSON, *Treasurer.*

Mr P. SYME, *Painter.*

Council.

Mr JOHN SHANKLIE.	The Rev. Dr ALEX. BRUNTON.
Mr JAMES STUART, Pinkie.	THOMAS CRANSTOUN, Esq.
Mr THOMAS INGLIS, Barnton.	GEORGE BELL, Esq.
Mr WILLIAM WRIGHT.	JOHN WAUCHOPE, Esq.
WALTER DICKSON, Esq.	Dr T. C. HOPE.
Mr JOSEPH ARCHIBALD.	Dr ROBERT GRAHAM.

Committee for Prizes.

Professor DUNBAR, *Convener.*

Mr JAMES WALKER.	DUNCAN COWAN, Esq.
Mr WILLIAM MACNAB.	The Rev. Dr ANDREW BROWN.
Mr JOHN BOYD.	The Rev. Dr DAVID RITCHIE.
ALEXANDER HENDERSON, Esq.	JOHN LEVEN, Esq.

Garden Committee.

Dr R. K. GREVILLE.	Mr WILLIAM MACNAB.
DANIEL ELLIS, Esq.	Mr JOHN HAY.
Dr JOHN YULE.	Mr JOHN LINNING, <i>Garden Treas.</i>

Mr JAMES BARNET, *Superintendent of the Garden.*

The Vice-President of the day, is *ex officio* a Member of the Committee for Prizes. The Secretary and Treasurer are *ex officio* Members of all Committees, where their assistance is required.

EXTRACTS
FROM THE
MINUTE-BOOK OF THE SOCIETY,
IN AS FAR AS RELATES TO THE
AWARDING OF PREMIUMS.

Continued from Vol. III. p. 42.

(The Society's SILVER MEDAL is to be understood, unless where otherwise specified.)

GENERAL MEETING, *June 3. 1819.*

THE Committee for Prizes reported, that several Melons had been examined, and that the best, in point of flavour, had been sent by Mr John Kyle, gardener to James Stirling, Esq. of Keir ; and the medal was accordingly assigned to Mr Kyle. Only one parcel of seedling Tulips had been presented ; but these being of good quality or promise, the medal was awarded to Mr Robert Elliot, gardener to Sir Thomas Gibson Carmichael, Bart., who transmitted them. A very fine collection of named sorts, or established flowers, having been exhibited, the flowers being particularly large and well formed ; it was agreed that an extra medal should be awarded to the cultivator, who proved to be Mr Alexander Forrester, gardener to David Falconar, Esq. of Carlowrie. The show of bouquets of border flowers was very fine. Some of the parcels being distinguished by

characters of excellence quite peculiar and of great importance, the Committee recommended that three prizes should be given: The first to Mr John Street, gardener to the Hon. Mrs Hamilton Nisbet of Biel, for a collection of flowers and flowering shrubs, cultivated in the open borders at Biel, containing above twenty exotic species which have hitherto been considered in this country as greenhouse plants, and several of which had, for the first time in Britain, been tried in the open air at Biel; the second to Messrs Dickson & Co. Leith Walk, for a bouquet containing sprigs of several rare exotic shrubs, which, though natives of warmer countries, have been so far naturalized that they have stood, without any protection but that of a wall, for some winters, in the Leith Walk Nurseries; the third to Mr James Cunninghame, gardener at Comely Bank, for a bouquet which, though not in strict conformity with the Society's proposals, was extremely rich and beautiful, abounding with Cape heaths, and various species of roses.

Mr Andrew Dickson presented to the Society, in name of Mr John Street, flower-gardener at Biel, a collection of seeds of tender exotics which ripened in the open air at Biel last autumn, and from which, in the course of two or three more generations, a more hardy progeny may be expected, according to the doctrine promulgated by Sir Joseph Banks.

COUNCIL MEETING, *July 1.* 1819.

The Committee for Prizes having met, a specimen of the Early green-fleshed Ionian Melon from Minto Garden, was tasted, and being much approved of, and having been sent at the desire of the Committee, they agreed to recommend that an extra medal be awarded to Mr Daniel Crichton, gardener to Lord Minto, who practises the culture of this fine variety.

Several fine collections of *Ranunculuses* were shewn ; and the Committee united in recommending that a medal should be awarded to Mr James Macdonald at Newington, for the great excellence of his flowers.

Two very superior collections of *Roses* were also displayed, the one excelling in variety, and the other in the size and shape of the flowers. The Committee voted a medal for the former, which was ascertained to belong to Messrs J. and G. Dicksons, Broughton Nurseries.

COUNCIL MEETING, *August 5. 1819.*

The Committee for Prizes having met, Mr Shade presented a collection of seedling Currants, Gooseberries, and Raspberries, raised at Pollock Garden by Mr Dugald Campbell, gardener to Sir John Maxwell, Bart. A white currant, marked No. 1. was remarkable for its sweetness, and a white gooseberry, marked No. 3. was distinguished for flavour. The Committee recommended the culture of these two, and desired the Secretary to request a plant of each for the use of the Society. Upon the whole, the Committee, regarding this communication as the most important they have lately received, and as tending directly to promote one of the principal objects of the Institution, agreed to recommend that the Gold Medal, or a piece of plate of five guineas value, be awarded to Mr Dugald Campbell.

A superb collection of Carnations was also displayed, consisting partly of stage-flowers, and partly of seedlings ; and the Committee agreed that a medal should be assigned to the cultivators, who were found to be Messrs C. and J. Peacock, Stanwell Lodge.

A bouquet of the rich and gorgeous flowers of *Tigridia pavonia*, raised in the open air by Mr Macnab, was shewn ; and the Committee agreed, that as this was a new and

splendid acquisition to our gardens, a medal should be awarded to Mr Macnab for introducing it at Edinburgh.

GENERAL MEETING, *September 2. 1819.*

The Committee for Prizes which met this day reported, that a very fine show of Fruits had been submitted to their inspection; and that, after a careful examination, they had determined that the prizes should be awarded as follows:

For the best Peaches from unflued walls, to Mr James Kirk, gardener to Lady Buchan Hepburn of Smeaton.

The best Peaches from flued walls,—to Mr George Shiells, gardener to the Right Hon. Lord Blantyre, Erskine-House.

The best Nectarines,—to Mr David Ford, gardener to the Right Hon. the Earl of Haddington, Tynningham.

The best Moorpark Apricots,—to Mr George Bain, gardener to Sir Hew Hamilton Dalrymple of North Berwick, Bart.

The best three sorts of Plums (greengages excepted), —to Mr James Kirk at Smeaton.

The best Greengages,—to Mr William Reid, gardener to Sir John Marjoribanks of Lees, Bart.

The best retarded Gooseberries,—to Mr James Walker, overseer at Melville Castle.

The best three sorts of Summer Pears,—to Mr George Kay, gardener at Restalrig.

The finest Pine-apple,—to Mr George Taylor, gardener to the Right Hon. the Earl of Kinnoul, Dupplin Castle.

The finest Black Hamburgh Grapes,—to Mr John Kyle, gardener to James Stirling, Esq. of Kier.

The largest cluster of White Muscat Grapes,—to Mr George Munro, gardener to William Hay, Esq. of Drummelzier, Dunse Castle.

The finest Seedling Carnations from seeds sown in 1817,—to Messrs C. and J. Peacock, Stanwell Lodge.

For White Currant Wine,—to Miss Orr, Broughton Place.

For Red Currant Wine,—to Mrs Marshall Gardiner, Few House.

For Elder-flower Wine,—also to Mrs Marshall Gardiner.

COUNCIL MEETING, *October 7. 1819.*

Some very fine specimens of the White French Cucumber, the largest of which exceeded 4 lb. in weight, were exhibited, and one tasted by the members present. The Committee agreed to recommend that the silver medal be awarded to Mr Thomas Inglis, gardener at Barnton, for his attention to the cultivation of this variety, which he has raised annually at Barnton for a number of years past.

Specimens of the White Buerré Pear of excellent quality, and large size, were presented by Mr John Mitchell, gardener, Moncrieff House. The Committee and Council, considering that this variety of pear is little known or cultivated in the neighbourhood of Edinburgh, recommend that a medal be awarded to Mr Mitchell, and that he be requested to communicate to the Society any remarks on this pear, its culture, &c.

COUNCIL MEETING, *November 5. 1819.*

Specimens of *Celosia cristata* or cockscomb, of very uncommon magnitude, were exhibited, sent from Tulliallan, the seat of Lord Keith, and raised by Mr Thomas Thomson,

gardener there. The Secretary was directed to request an account of the mode of culture; and the meeting agreed to recommend that the Society's silver medal be awarded to Mr Thomson.

GENERAL MEETING, *December 2. 1819.*

The Committee for Prizes which met this day reported, that a very considerable show of choice Apples and Pears had been submitted to them, and that they had determined that the prizes should be awarded as follows:

For the best three sorts of Apples not generally cultivated in Scotland, but which have been found to ripen well,—to Mr James Kirk, gardener to Lady Buchan Hepburn of Smeaton.

For the best three kinds of French Pears produced in Scotland,—to Mr Alexander Kelly, gardener to the Right Hon. the Earl of Moray.

For the best six Achan Pears,—to Mr Mathew Frazer, gardener to the Duchess-Dowager of Roxburgh and Mr Manners at Broxmouth.

The Committee further reported, that a communication of considerable importance had been received from Mr Robert Ingram, gardener at Torry, accompanied with specimens, shewing that the Gansel's Bergamot, when budded or grafted on the Swan-egg Pear-tree, yields fruit of greatly superior quality; and they recommended that an extra medal should be awarded to Mr Ingram, which was agreed to.

The Secretary reported from the Council, that the medal for the finest drawing of Scottish fruit had been assigned to Miss Borthwick of Crookston: That the annual gold medal given for the most important communication printed in the Society's Memoirs, had been voted to Samuel Parkes, Esq. for his Essay on the Use of Sea-salt in Horticul-

ture : That the medal to gardeners for long and faithful service, had this year been given to Mr James Moffat, who has been for forty-eight years gardener to the family of Fordyce of Ayton : And, lastly, 'That the Council recommended that the Society's silver medal should be awarded to Mr Alexander Smith, gardener to Thomas Bruce, Esq. of Grangemuir, for his invention of paper-screens for protecting the blossom of wall-trees from spring frosts.

COUNCIL MEETING, *February 3. 1820.*

A basket of fine fruit from Hailes Garden was exhibited, as a specimen of the result of heading down and regrafting some old and cankered fruit-trees only three years ago. The Council, considering the remarkable success of Mr John Clephane, the gardener, in this operation, by which so many years' enjoyment may be saved to the proprietors of gardens, recommended that the Society's silver medal be awarded for his encouragement.

GENERAL MEETING, *March 4. 1820.*

The Committee for Prizes, which met this day, reported,

1. That several parcels of Brussels Sprouts had been examined ; and that the most genuine sort, having the rosettes tender and well cabbaged, was found to belong to Mr James Arklie, gardener to Sir Thomas Trowbridge, Bart. of Rockville, to whom accordingly the medal was assigned.

2. That two very excellent assortments of dessert apples had been submitted to the Committee ; and that, after a careful examination, and a fair consideration of all circumstances, they had come to a resolution to recommend to the meeting to award a medal to each. On opening the sealed letters, the one parcel was ascertained to have been sent by Mr George Munro, gardener to Mr Hay of Drum-

melzier, at Dunse Castle ; and the other to have been sent by Mr James Macdonald, gardener to his Grace the Duke of Buccleuch at Dalkeith Park.

COUNCIL MEETING, *April 6. 1820.*

The Secretary reported, that a very remarkable Shaddock, and several fine specimens of Lemons, having been sent for inspection by the Earl of Wemyss, he had invited members to view these fruits at the shop of Messrs Dickson and Co. Several gentlemen having expressed their opinion that a mark of the Society's approbation should be given to Mr Walter Henderson, gardener at Woodhall, who raised these specimens, the silver medal was accordingly voted to him.

COUNCIL MEETING, *April 27. 1820.*

There was this day a great display of Auriculas ; and the Committee recommended that three medals should be given. 1. For those from Mr Leven's garden at Burnt-island ; 2. For those from Sir Alexander Muir Mackenzie's garden at Delvine ; and, 3. For those from Mr Macdonald's garden at Newington.

GENERAL MEETING, *June 1. 1820.*

The Secretary gave in the following report from a Committee appointed by the Council to visit certain gardens, the superintendants of which had intimated their intention of competing for the honorary gold medal offered by the Society to the gardener who should have his master's garden, being within ten miles of Edinburgh, in the best order in the first week of May :

“ In the beginning of May, the Committee visited eight gardens, all of which were in good order. They found considerable difficulty in coming to a decision as to the garden

which might be said to be in the *best* order, on account of the very various circumstances which characterised the different gardens, such as the extent of ground to be kept in order,—the number of hands employed,—the gardener having the care of hot-houses or not, &c. Upon the whole, they recommend, that the gold medal be awarded to Mr John Macnaughton, gardener to Colonel Wauchope of Edmonstone; but as the Committee was divided in opinion as to the comparative merit, in point of keeping, of Edmonstone garden and that of Pinkie, they unanimously concur in recommending that an extra silver medal be awarded to Mr James Stewart, gardener to Sir John Hope, Bart. of Pinkie. They farther recommended, that the Society's silver medal be voted to Mr David Weighton, gardener to Thomas Williamson, Esq. of Lixmount, on account of his great merit in keeping the garden there in high order, almost wholly by his own exertions."

The Committee of Prizes which met this day, reported,

1. That the medal for the best Early Melon should be awarded to Mr George Dickson, gardener to Andrew Wauchope, Esq. of Niddry.

2. That the medal for the best three kinds of Apples fit for the dessert at this season, should be given to Mr George Munro, gardener to William Hay, Esq. of Drummelzier at Dunse Castle.

3. That several small collections of very fine greenhouse plants, in pots, had been exhibited, and that the Committee recommended that a first and second medal should be awarded; and on opening the sealed letters, the first was found to be due to Mr William Tod, gardener to Professor Dunbar at Rose Park; and the second to Mr James Cunninghame, botanical nurseryman at Comely Bank.

The Committee farther reported, that a great variety of Geraniums, raised from seed, at Biel, in East Lothian, were exhibited in full flower, and that some of them were remarkable for beauty and for copious flowering; the Committee therefore recommend to the general meeting to award the Society's silver medal to Mr John Street, flower-gardener to the Hon. Mrs Hamilton Nisbet of Biel, the encouragement of seedling productions being an important object of the Society.

COUNCIL MEETING, *July 6. 1820.*

Specimens of a Seedling Nectarine, raised at Woodhall by Mr William Henderson, were presented, and met with general approbation. The fruit was of good size, juicy, and of a rich sugary flavour, resembling the elruge; and the tree was stated to be a free and copious bearer. The Council and Committee considering the production of a new nectarine of such excellent quality, and which promises to improve as the tree advances in years, unanimously agreed to recommend to the next general meeting to award the Society's silver medal, without prejudice to any future and further mark of approbation.

GENERAL MEETING, *Sept. 7. 1820.*

The Vice-President stated, that the Council of the Society, with the view of giving both dignity and permanence to the Institution, had directed him, a short time ago, to write to the Earl of Hopetoun, their present President, requesting that he would endeavour to obtain the consent of **THE KING** to become the Patron of the Society, and that Lord Hopetoun had, within these few days, transmitted to him a letter from Lord Sidmouth, Principal Secretary of State for the Home Department, informing him that His Majesty had condescendingly agreed

to become the Patron of the Caledonian Horticultural Society; and he further stated, that Lord Hopetoun had also transmitted letters from the Secretaries of their Royal Highnesses the Dukes of York and Clarence, accepting of the rank of Honorary Members of the Society, on the part of these Royal Dukes. The Society approved of these steps taken by the Council, for promoting the honour and interest of the Institution; and they directed the Secretary to return grateful thanks to the Right Hon. the Earl of Hopetoun for his good offices in this business.

A very great collection of fine fruit was this day submitted to the Committee. After the most careful consideration, they reported that they had awarded the premiums as follows:

For Peaches from unflued walls,—to Mr George Bain, gardener to Sir Hew Dalrymple, Bart. North Berwick House.

For Peaches from flued walls, without glass,—to Mr George Dickson, gardener to A. Wauchope, Esq. of Niddry.

For Nectarines,—to Mr George Shiells, gardener to the Right Hon. Lord Blantyre, Erskine House.

For Moorpark Apricots, two medals, on account of two parcels being of such equal merit that the Committee found difficulty in deciding betwixt them,—
1. To Mr John Christie, gardener to Ebenezer Gilchrist, Esq. of Sunnyside; 2. To Mr George Bain, North Berwick House.

For the best three sorts of Plums,—to Mr David Lindsay, gardener to Sir James Colquhoun, Bart. Rosedoe.

For the best Greengage Plums,—to Mr James Walker,

gardener to the Right Hon. Lord Melville, at Melville Castle.

For the best retarded Gooseberries (the Red Warrington),—to Mr John Clephane, gardener to John Balfour, Esq. Hailes.

For the best three sorts of Summer Pears (Jargonelle or cuisse-madame, Summer Auchan, and Crawford),—to Mr John Kyle, gardener to James Stirling, Esq. of Keir.

For the best specimen of Pine-apple (Queen),—to Mr David Ford, gardener to the Right Hon. the Earl of Haddington, Tynningham.

For Black Hamburg Grapes,—to Mr William Wright, gardener to the Right Hon. the Earl of Rosebery, Dalmeny Park.

For White Muscat Grapes,—to Mr John Clephane, gardener to John Balfour, Esq. Hailes.

For Grizzly Frontignac Grapes,—to Mr George Brown, gardener to the Right Hon. the Earl of Lauderdale, Dunbar House.

For the best three kinds of Summer Apples,—to Mr Alexander Forrester, gardener to David Falconar, Esq. of Carlowrie.

For the finest Seedling Carnations,—to Mr David White, gardener to General Balfour, Whitehill, by Lasswade.

The Committee farther reported, that several uncommon productions deserved special notice, and merited, in their opinion, extra medals, notwithstanding the great number of premiums already voted this day. In particular, two new varieties of Seedling Peach were exhibited; one from Edmonstone, the garden of Colonel Wauchope, and another (together with a seedling Nectarine), from the garden of Lord Lyndoch. Both were of excellent charac-

ter ; and as the production of seedling fruits is an important object of the Society, the Committee had no hesitation in awarding an extra medal to Mr John Macnaughton, gardener at Edmondstone, and another to Mr Robert Hosie, gardener at Lyndoch.

A very fine specimen of the variety called Blood Pine-apple, or Claret Pine-apple, was produced ; and as this is rare in Scotland, the Committee awarded an extra medal to Mr John Aiton, gardener to W. H. Nisbet, Esq. of Archerfield, who sent it.

Some very large and beautiful specimens of Double-flowered Dahlias were exhibited ; and the Committee awarded an extra medal to the cultivator, Mr Alexander Stewart, gardener to Sir Robert Preston, Bart. Valleyfield.

The Committee for trying Home-made Wines gave in the following report :

“ Edinburgh, 7th September 1820.

“ The Committee beg leave to report, that the best wine produced this day is that with the motto, “ Never venture never win,” and which, upon opening the sealed letter, was ascertained to have been made by Mrs Mackinlay, Hermitage.

“ The Committee recommend that an extra medal be given for Gooseberry Champagne, several excellent specimens of which were produced. If the Society approve of this recommendation, the Committee suggest that the champagne made at Halyburton by M. Louis Petnard, merits the reward.

“ The Committee cannot conclude without observing, that a considerable improvement is observable, in their opinion, in the various wines produced, which are superior to what they have met with in former years.”

A communication from Mr John Young, surgeon, having been read, announcing that he had delivered to Messrs Cheyne of the Apothecaries' Hall, Edinburgh, 30 lb. weight of Lactucarium, prepared this year, together with a certificate from Messrs Cheyne that they had purchased the same, it was moved by Dr Duncan, and unanimously agreed to, that the Society's gold medal be awarded to Mr Young for his long continued and meritorious exertions in the preparation of this important medicine, by which he has greatly contributed toward its general introduction into medical practice.

COUNCIL MEETING, *October 5. 1820.*

Specimens of the Hailes Seedling Plum were laid before the meeting; and the fruit being approved of as a promising standard plum, it was unanimously agreed that the Society's silver medal be awarded to Mr John Clephane who raised it.

COUNCIL MEETING, *December 1. 1820.*

Mr John Peacock, the Assistant-Secretary, stated, that the new Kinfauns Apple had remained in good preservation till this time, so that it may be regarded as a keeping apple; and a specimen having been again tried and universally approved of, the Council were of opinion that the silver medal should be awarded to Mr William Campbell, gardener to the Right Hon. Lord Gray, the raiser of this excellent seedling.

GENERAL MEETING, *December 7. 1820.*

The gold medal annually given by the Society for the communication of greatest importance received in the course of the preceding year, was presented to Dr William Howi-

son, for his communications respecting fruits and vegetables cultivated in Russia.

The Committee for Prizes reported, that several fine samples of fruit had this day been brought forward ; and that the medals ought to be awarded as follows :

For the best three sorts of Apples,—to Mr Robert Reid, gardener to Sir Alexander Keith of Ravelstone.

For the best Colmar, Chaumontelle, and Crasanne Pears,—to Mr David Macewan, gardener to Sir James Hall, Bart. Dunglass.

For some other very fine specimens of Pears, an extraordinary medal,—to Mr John Kyle, gardener to James Stirling, Esq. of Keir.

For the best Achan Pears, from standards,—to Mr James Stewart, gardener to Sir John Hope, Bart. of Pinkie.

GENERAL MEETING, *March 8. 1821.*

It was reported from the Council, that the medal for 1820, to the head-gardener who should be found to have served for the longest period the same family with fidelity and attention, &c. ought to be awarded to Mr John Kyle, who had been chief gardener at Blair-Drummond for 42 years.

The Committee for Prizes reported, that premiums had been awarded as follows :

For the best six heads of Cape Broccoli,—to Mr James Arklie, gardener to Sir Thomas Trowbridge, Bart. at Rockville.

For the best six heads of Brussels Sprouts,—to Messrs Dicksons and Co. Leith Walk, who have procured from the seed a dwarfish but remarkably genuine

subvariety, the rosettes or sprouts being quite compact like cabbages in miniature.

For the best six kinds of Apples fit for the dessert at this season,—to Mr John Macnaughton, gardener to Colonel Wauchope of Edmonstone.

COMMITTEE MEETING, *April 26. 1821.*

To-day there was a great display of Stage Auriculas and Polyanthuses, about 100 pots with choice auriculas being produced. After a careful examination, the Committee recommended the awarding of the medals as follows :

1. To Alexander Henderson, Esq. 99. High Street, for the finest Stage Auriculas.
2. To John Linning, Esq. for a collection of very beautiful Auriculas.
3. To Mr William Henderson, gardener to Sir Alexander Muir Mackenzie, Bart. at Delvine, for a collection of Auriculas, remarkable for the luxuriance of their growth, and for an account of his mode of cultivating the plant.
4. To Mr Alexander Forrester, gardener to David Falconar, Esq. of Carlowrie, for a remarkably large and curious seedling Auricula.
5. To Messrs Dickson and Co. Waterloo Place, for the finest Stage Polyanthuses.
6. To Mr David Anderson, Brown Street, Newington, for the best Seedling Polyanthuses.

There was also exhibited a collection of the flowers of the Garden Hyacinth, which had been cultivated for several years in the Royal Botanic Garden here, and which, for health and luxuriance, were equal to those yearly imported from Haarlem. The Committee agreed in recommending the awarding of a medal to Mr William Macnab, the superintendent, for his successful culture of this fine flower.

The boast of the day still remains to be mentioned. This consisted in several fine plants of the Citrus tribe in flower and fruit. Instead of having their heads pruned into the shape of balls, these plants were of their native graceful forms. But to those unacquainted with the usual mode of culture of orange-trees, the surprise was not small when it was found that the largest plants (Seville and myrtle-leaved orange-trees, loaded with ripe and unripe fruit) were only four years from the bud or graft, and that a plant now in flower was a cutting little more than a year old. These specimens were from the garden at Woodhall, the seat of Colonel Campbell of Shawfield near Holytown, and were carried to town by two of the gardeners on a handbarrow, covered with an awning. The Committee unanimously voted the Society's medal to Mr Walter Henderson, gardener at Woodhall, and desired the Secretary to write, requesting him to communicate a full account of his mode of cultivating the Citrus family, when the Committee would move the Society to bestow some further honorary mark of their approbation. They also authorised the Treasurer to present half a guinea each to the gardeners who transported the plants so far in safety.

GENERAL MEETING, *June 7. 1821.*

The Committee for Prizes reported, that prizes had this day been awarded as follows :

For the best Early Melon (Kew Cantelope),—to Mr John Kyle, gardener to James Stirling, Esq. of Keir.

For the best Seedling Tulips,—to Mr Alexander Forrester, gardener to David Falconar, Esq. of Carlowrie.

For very fine named Tulips, two prizes,—1. To Mr Alexander Forrester, Carlowrie ; 2. To Mr James Macdonald, Newington.

For the best Apples fit for the dessert at this season,
—to John Ker, Esq. of Kerfield.

GENERAL MEETING, *September 6. 1821.*

The Committee for Prizes reported, that premiums were awarded as follows :

For the best twelve Peaches (Gallande) produced without artificial heat in the open air,—to Mr James Arklie, gardener to Sir Thomas Trowbridge, Bart. Rockville.

For the best twelve Peaches (Noblesse), from flued walls, without glass,—to Mr David Ford, gardener to the Right Hon. the Earl of Haddington, Tynningham.

For the best twelve Nectarines from flued walls, without glass,—to Mr David Ford, Tynningham.

For the best twelve Moorpark Apricots,—to Mr Thomas Spalding, gardener to Mr Macnab of Arthurstone.

For the best three sorts of Plums, six of each sort, viz. Orleans, Magnum-bonum, and Blue Gage,—to Mr William Reid, gardener to Sir John Marjoribanks, Bart. of Lees.

For the best twelve Green Gage Plums,—to Mr Philip Shillinglaw, gardener to the Right Hon. the Earl of Kinnoul, Duplin Castle.

For the best Scots pint of retarded Gooseberries,—to Mr William Affleck, gardener to T. G. Wright, Esq. Duddingstone Cottage.

For the best Pine-apple,—to Mr Alexander Muirhead, gardener to A. H. M. Belshes, Esq. of Invermay.

For the best three bunches of Black Hamburgh Grapes,
—to Mr Philip Shillinglaw, Dupplin Castle.

For the largest and heaviest bunch of White Muscat Grapes,—to Mr David Ford, Tynningham.

For the best three sorts of Summer Apples, a dozen of each kind,—to John Ker, Esq. of Kerfield.

Extra prize for Pine-apples,—to Mr James Simpson, gardener to Captain Wemyss, Wemyss Castle.

Extra prize for Black Hamburgh Grapes,—to Mr Alexander Macdonald, gardener to George Ramsay, Esq. Inchrye.

For the best Home-made Wine,—to Mrs Husband Baird, near Dunfermline.

Extra medal for Currant-Wine,—to Mrs Dr Duncan, Adam's Square.

The 12th annual Dinner was afterwards served in Oman's Waterloo Tavern, George Bell, Esq. one of the Vice-Presidents, in the chair. The Secretary of the Society, Mr Neill, being absent on a tour through France, on his health being given from the chair, Sir George Mackenzie, one of the Vice-Presidents, addressed the meeting, and after paying some compliments to Mr Neill, proposed that the Society should present him with a piece of plate, of fifty guineas value, as a mark of their esteem, and of gratitude for the services he had rendered to the Society. This proposal was received with acclamation.

J. P. *Asst. Sec.*

GENERAL MEETING, *December 5. 1821.*

The Committee for Prizes reported,

1. That the medal offered for the best three sorts of Apples lately introduced, or not generally known in Scotland, and which have been found to ripen well on standard or espalier trees, has been awarded to John Ker, Esq. of Kerfield; and that two sorts of French apples, marked as having been introduced about thirty years ago by the late

Lord Dundas into his garden at Kerse, deserve particular notice and commendation.

2. They have to state, that, although the late season has in general proved unfavourable to the production of the finer kinds of Pears in Scotland, yet some parcels of considerable merit were submitted to the Committee, and that they judged it expedient to award two medals; the first to Mr William Pearson, gardener to the Right Hon. the Earl of Hopetoun, at Ormiston Hall; and the second to Mr Peter Barnet, gardener to Robert Bruce, Esq. of Kennet, M. P.

3. Several specimens of the John Monteith Pear were produced, and the Committee awarded the medal to Mr John Macnaughton, gardener to Colonel Wauchope of Edmondstone; but they are of opinion that the cultivation of this old variety of pear is scarcely deserving of the farther encouragement of the Society.

4. Two very promising Seedling Apples were produced to the Committee; and the Society having intimated, in the Prize List, that the "silver medal will be awarded for every seedling apple of merit, produced subsequently to 1818," they accordingly adjudged a medal, 1st, To Mr John Macnaughton, Edmondstone, for an apple from American seed; and, 2d, To Mr John Edwards, Luncarty, for a seedling of great promise.

The Society having offered a medal to "the cultivator who shall produce to the Secretary or to the Committee the greatest number of specimens of the Iris in flower, with a communication stating the proper botanical and English names, also their manner of growth, culture, and management, the Committee beg leave to report, that this medal is due to David Falconar, Esq. of Carlowrie, who, by letter, requested that, if he should prove successful, the medal be awarded in name of his gardener Mr Alexander Forrester.

The Council of the Society which met this day farther recommended to the Society, that an extra medal should be awarded to Mr William Laidlaw, gardener to David Anderson, Esq. of Moredun, for several very large bunches of the White Muscat and Syrian Grape, produced in the finest condition at so late a period of the year.

COUNCIL MEETING, *January 10. 1822.*

The Secretary laid before the meeting the plan of a Flower-border, &c. for which a premium had been offered last year ; and although only one competitor had appeared, they were of opinion, that, as the plan had been approved of by those who had examined it, and must have cost the author much trouble and pains, not only the Society's silver medal should be awarded, but two guineas in addition, or, in his option, a piece of plate of $3\frac{1}{2}$ guineas in value. The plan, &c. was found to be the work of Mr John Street, flower-gardener to the Hon. Mrs Hamilton Nisbet of Biel.

GENERAL MEETING, *March 14. 1822.*

Upon report of the Committee for Prizes, two honorary medals were awarded as follows :

For the three finest plants of *Camellia Japonica*, in full flower,—to Mr James Cunninghame, Comely Bank.

For several very beautiful and rare Exotic Shrubs, in flower,—to Professor Dunbar, Rose Park, Trinity.

For uncommonly large specimens of Seville Orange, produced in the Orangery at Valleyfield, and for splendid plants of *Bletia Tankervilleæ*, in flower,—to Mr Alexander Stewart, gardener to Sir Robert Preston, Bart.

For continued attention to the important object of naturalising tender Exotic Shrubs,—to Mr John Welsh, gardener to George Robertson, Esq. Greenock.

For his success in restoring the vigour of imported Hyacinth Bulbs which had been forced in this country,—to Mr John Street, flower-gardener to the Hon. Mrs Hamilton Nisbet of Biel.

COMMITTEE MEETING, *April 25. 1822.*

A very extensive and rich shew of stage auriculas took place, and the Committee felt considerable difficulty in coming to a decision, different collections possessing different excellencies; some being remarkable for the general strength of growth of the plants; others for the great variety of flowers exhibited; and others still for containing two or three very choice flowers. The Committee resolved, for this year, to adopt the principle of preferring the greatest variety and strongest growth; but even then they felt unable to decide between two collections, and therefore awarded a medal for each. On opening the sealed letters, these collections were found to belong to Mr William Henderson, gardener to Sir Alexander Muir Mackenzie, Bart. of Delvine, and to Messrs Charles and John Peacock, nurserymen and florists, Stanwell, Leith Walk.

Two parcels of very promising Seedling Auriculas were also shewn; and a medal awarded for one of these, which was found to belong to Mr James Macdonald, Newington.

Two parcels of Seedling Polyanthus having also been shewn, the Committee voted a medal for one of them, which proved to have been sent by Messrs Eagle and Henderson, of the Meadowbank Nurseries.

GENERAL MEETING, *June 13. 1822.*

Upon report from the Committee for Prizes, which met this day, the Society's silver medal was awarded,

1. To Mr Hugh Austin, nurseryman, Glasgow, for the largest and finest collection of varieties of Scots Roses.

2. To Messrs Dicksons and Company, Edinburgh, for a collection of twelve beautiful Seedling Scots Roses, raised by them at the Leith Walk Nurseries.
3. To Mr William Henderson, gardener to Sir Alexander Muir Mackenzie, Bart. of Delvine, for the best Early Melon (the Green-fleshed Ionian).

Upon a report from the same Committee, a medal was also voted to Mr John Ross, gardener to his Grace the Duke of Atholl, for having, in May last, sent to the Society a specimen, in full flower, of the *Bromelia nudicaulis*, this being the first instance of this rare plant having flowered in Scotland.

COMMITTEE MEETING, *July 11. 1822.*

The Committee examined the exotic plants exhibited for competition, and decided that the medal for the four finest be awarded to a parcel containing *Nerium splendens fl. pl.*, *Gladiolus cardinalis*, *Erica pulverulenta*, and *Crassula versicolor*, and which was ascertained to belong to George Dunbar, Esq. Rose Park, Trinity.

Some very rich and beautiful varieties of the garden Balsam (*Impatiens Balsamina*) were considered worthy of an extra medal, and were found to be sent by Mr William Macnab of the Royal Botanic Garden.

GENERAL MEETING, *August 10. 1822.*

Dr Duncan senior, First Vice-President in the chair.— Dr Duncan stated, that the only business of this meeting was to consider of the propriety of voting an address to His Majesty's King George the Fourth on occasion of his visiting Scotland; and he produced and read the draft of a congratulatory address, which was unanimously agreed to, and the Right Hon. the Earl of Wemyss, President,

and Henry Jardine, Esq. Vice-President, were requested to carry the measure into effect. The following is a copy of the address :

“ To the King’s Most Excellent Majesty.

“ *May it please your Majesty,*

“ WE, your Majesty’s faithful subjects, the President and Members of the Caledonian Horticultural Society, beg leave to approach the Throne with our sincere congratulations on your Majesty’s first visit to the metropolis of Scotland.

“ Our Society, begun under your government as Regent of the British Empire, had the singular honour of being patronised by your Majesty soon after our first institution. Of this honour we gave a public acknowledgment, by dedicating to you, in consequence of your Royal permission, the first fruits of our literary labours. And we flatter ourselves, that the Memoirs of our Society have had the effect of introducing into this country important improvements in one of the most interesting, the most useful, and the most healthful of rural employments.

“ Scotland has long indeed been distinguished for skilful professional gardeners. But although much has been discovered, much yet remains to be discovered ; and we flatter ourselves with sanguine hopes, that your Majesty’s reign will be distinguished to the latest ages by the progress of horticultural improvements.

“ Permit us, Sire, to conclude this congratulatory address, by uniting our earnest prayers with those of every other true Briton, that your Majesty’s reign may be long, glorious, and eminently marked, by the progressive advancement of the arts of Peace.

“ May it please your Majesty, your Majesty’s most faithful subjects, the President and Members of the Caledonian Horticultural Society.

“ Signed in our name, and by our appointment, by

“ CHARTERIS, WEMYSS, & MARCH, *President.*”

EDINBURGH, }
10th August 1822. }

Memorandum.—The above address was presented to the King, at the levee held at Holyroodhouse on Saturday 17th August, by the Earl of Wemyss, President, and Dr Duncan senior, First Vice-President of the Society; and afterwards published in the Edinburgh Gazette of Friday, 23d August.

A copy of the second volume of the Society's Memoirs, elegantly bound, was likewise transmitted to the King by the Earl of Wemyss, and receipt of it acknowledged in a letter to his Lordship from Mr Peel, Secretary of State for the Home Department.

GENERAL MEETING, *September 5. 1822.*

Upon report of the Committee for Prizes, premiums were awarded as follows:

For the best Peaches from open walls, without artificial heat,—to Mr John Mitchell, gardener to Sir David Moncrieff, Bart. Moncrieff House.

Peaches from flued walls, without glass,—to Mr Thomas Inglis, gardener to the Hon. Mrs Ramsay, Barnton.

Nectarines from flued walls, without glass, to Mr Kinmont, gardener to Miss Yeaman, Murie.

Moorpark Apricots,—to Mr John Clark, gardener to the Earl of Wemyss, Gosford.

Best six sorts of Plums (Green Gages excepted),—to Mr Alexander Bisset, gardener to Colonel Smyth, Methven Castle.

Best Green Gages,—to Mr John Kyle, gardener to Mr Stirling of Keir.

Best Scots pint of retarded Gooseberries,—to Mr John Clephane, gardener to Mr Balfour, Hailes.

Best six sorts of Summer Pears,—to Mr John Kyle, Keir.

Pine-apples,—to Mr Philip Shillinglaw, gardener to the Earl of Kinnoul, Dupplin Castle.

Largest Grapes (Gibraltar),—to Mr William Wright, gardener to the Earl of Rosebery, Dalmeny Park.

Best six kinds of Summer Apples,—to Mr Thomas Dewar, gardener to the Earl of Wemyss, Queen Street.

Finest Carnations,—to Mr David White, gardener to General Balfour, Whitehill.

Finest Double Dahlias,—to Mr Alexander Forrester, gardener to David Falconar, Esq. of Carlowrie.

Beautiful Seedling Dahlias, several of them double-flowered,—to Mr William Macnab, superintendant of the Royal Botanic Garden, Edinburgh.

The greatest variety of Fruits, of good quality, produced to the meeting,—to Mr Alexander Bisset, Methven Castle.

A collection of Peaches and Nectarines of excellent quality (received some hours too late for the competition on Wednesday the 4th), an extra medal,—to Mr James Young, gardener to James Richardson, Esq. of Pitfour.

A new melon, raised at Barnton, near Edinburgh, was presented to the meeting. It was of an uncommon size, weighing 21 lb. 8 oz., and of fine flavour, bred between the Bassey Rock and Romana, and had received the name of “King George the Fourth’s Melon.” An extra medal was unanimously voted to Mr Thomas Inglis for this production.

A number of different specimens of Home-made Wine having been examined by a select Committee, they reported, that two medals ought to be awarded for excellent wines, one to Mrs Stewart of Newton, near Doune, and another to Mrs Lambert, St Andrew’s.

Mr John Street, flower-gardener at Biel, having presented a number of specimens of naturalized exotic plants, with packets of seeds saved from them in the open air, it

was recommended to him to persevere in his experiments, and, in the mean time, the Society's silver medal was voted to him for his continued attention to this interesting department of horticulture.

COUNCIL MEETING, *October 3. 1822.*

Mr Walter Dickson laid before the meeting some very admirable specimens of the finer French pears, &c. from the garden of the Earl of Wemyss at Gosford House. Thanks were voted to Lord Wemyss, and the silver medal was awarded to Mr John Clerk, his Lordship's gardener, for his great proficiency in the production of such fruits.

The Secretary laid before the meeting specimens of the Canaan Apple, a seedling raised by Mr Alexander Adie, optician; parent kinds not known. This new apple was found to possess such excellent qualities, that the Council agreed immediately to award the silver medal to Mr Adie for this production.

COUNCIL MEETING, *November 14. 1822.*

A bunch of Black Hamburg Grapes, ripened against a flued wall, without glass, at Erskine-House Garden, under the care of Mr George Shiells, was exhibited and tasted. The berries were found to be thoroughly ripe, and of high flavour. Mr Shiells having made this experiment at the suggestion of the Council, and completely succeeded, the Council unanimously voted to him the Society's silver medal.

GENERAL MEETING, *December 5. 1822.*

The annual gold medal for the most important communication received during the past year was awarded to Mr Walter Henderson, gardener, Woodhall, for his essay on the culture of the Citrus tribe, &c.

The Committee for Prizes then gave in their report, bearing, that the medals for this day had been awarded as follows :

For the best three sorts of Apples not generally known in Scotland, &c.—to Mr John Taylor, gardener to the Right Hon. the Earl of Dunmore, Dunmore Park.

For the best Pears,—to Mr Andrew Pace, gardener to Sir John Dalrymple, Bart. at Oxenford Castle.

Two very fine specimens of retarded Grapes having been presented, the Committee suggested that two prizes should be awarded, one to Mr John Kyle, gardener to James Stirling, Esq. of Keir ; and another to Mr John Clephane, gardener to John Balfour, Esq. Hailes.

Some Seedling Pears of great promise having been sent from Dunmore Park, it was recommended that an extra medal should be awarded to Mr Taylor for their production.

A Seedling Apple from Corstorphine Hill, from the seed of an American fruit, being thought to possess qualities which may render it desirable as a new orchard and market apple, a medal was voted to Mrs Keith, who raised it.

Very excellent specimens of Citrons, bitter and sweet oranges and limes, having been sent from Valleyfield, it was recommended that an extra medal be awarded for their production to Mr Alexander Stewart, gardener to Sir Robert Preston, Bart.

The Committee further reported, that it would be proper to award two medals to head-gardeners for long service ; one to Mr Alexander Key, whose certificate, signed by Lord Glenlee, bore, that he had been gardener at Barskimming for 54 years ; and another to Mr William Reid, whose certificate by Lady Kinloch stated, that he had been gardener at Gilmerton for 52 years ; both having success-

fully exercised all the branches of their profession, and conducted themselves with uniform propriety during these long periods.

COUNCIL MEETING, *January 10. 1823.*

Mr Archibald Gorrie's meteorological report for 1822, (kept at Annat garden, Errol), having been communicated to the meeting, they unanimously recommended that the silver medal be awarded to Mr Gorrie, for his zeal in meeting the wishes of the Society in this respect.

COUNCIL MEETING, *February 6. 1823.*

The Council unanimously approved of a recommendation from the Committee of Prizes as to awarding to Robert Johnston, Esq. the silver medal as a mark of approbation of his zeal in forwarding the objects of the Institution, in procuring a collection of the best apples of Canada from Montreal, with an offer of grafts when the Experimental Garden should be ready to receive them.

The Council took into consideration a motion made by Mr Robert Smith, and seconded by Mr John Linning, relative to the propriety of the Society marking, by voting a piece of plate, its high approbation of the valuable services of the Treasurer, Mr Andrew Dickson, for fourteen years past; and unanimously agreed to recommend to the General Meeting in March next to present to Mr Dickson a piece of plate not exceeding fifty guineas in value, with a suitable inscription.

GENERAL MEETING, *March 13. 1823.*

The minutes of last general meeting, and of the meetings of Council in January and February last, having been read, it was moved by Robert Smith, Esq. That the

minutes be approved of, and particularly that the meeting give their hearty approbation to the proposal of bestowing on the Treasurer of the Society, Andrew Dickson, Esq. a mark of their high opinion of the zeal and fidelity with which he has discharged the duties of that important office for fourteen years past. This motion having been seconded by Henry Jardine, Esq. was unanimously adopted, and the Council were instructed to carry into effect their vote in favour of Mr Dickson.

The Committee for Prizes which met this day then reported, that prizes should be awarded as follows :

For the best six kinds of Apples from standards or espaliers, fit for the dessert at this season, two prizes ; —one to Mr John Macnaughton, gardener to John Wauchope, Esq. of Edmonstone ; and another to Mr James Culbert, gardener to John Ker, Esq. of Kerfield.

For the best twelve roots of Scorzonera,—to Mr David Ford, gardener to the Right Hon. the Earl of Haddington, Tynningham.

For the best twelve roots of Salsify,—to Mr George Brown, gardener to the Right Hon. the Earl of Lauderdale, Dunbar House.

The Committee further recommended, that extra prizes should be awarded for the following productions :

For beautiful specimens of Apples, some of them rare or new, and for excellent samples of the smooth Caroon of Paris,—to Mr James Morison, gardener to William Grant, Esq. of Congalton.

For several bunches of retarded and preserved Black Hamburgh Grapes,—to Mr John Clephane, gardener to John Balfour, Esq. Hailes.

For specimens, in flower, of Hyacinths and Polyanthus-

narcissuses, restored to vigour, after having been forced in this country two years ago, and for a dwarf variety of Clove-carnation,—to Mr John Street, flower-gardener to the Hon. Mrs Hamilton Nisbet of Biel.

COMMITTEE MEETING, *May 7. 1823,*

(*Delayed from 24th April on account of the lateness of the season.*)

To-day the display of Auriculas and Polyanthuses, both stage-flowers and seedlings, was more extensive and brilliant than on any former occasion.

For Stage-Auriculas, two prizes were awarded; 1st, To Thomas Oliver, Esq. West Newington; 2d, To Mr Alexander Forrester, gardener to David Falconar, Esq. of Carlowrie.

For Seedling Auriculas, also two prizes: 1st, To Mr William Henderson, gardener to Sir Alexander Muir Mackenzie, Bart. of Delvine; 2d, To Mr David Anderson, Brown Street.

For Stage-Polyantheses,—to Messrs Dickson and Co. of the Leith Walk Nurseries.

For Seedling Polyantheses,—to Messrs Dicksons.

An extra medal to Mr Forrester at Carlowrie, for a peculiarly beautiful Seedling Polyanthus, having two dark colours.

An extra medal to Mr Duncan Mackay, gardener to Robert Baird, Esq. of Newbyth, for specimens of very large and fine Mushrooms raised by him.

GENERAL MEETING, *June 12. 1823.*

The Committee for Prizes reported, that premiums ought to be awarded as follows:

For the best twelve named Anemones,—to Messrs Dicksons and Co. Leith Walk.

- For a collection of very fine named Tulips,—to James Macdonald, Esq. Newington.
- For the best Apples fit for the dessert at this season,—to Mr James Macdonald, gardener to his Grace the Duke of Buccleuch, Dalkeith.
- For specimens of a very promising Seedling Apple,—to Alexander Thomson, Esq. of Banchory, 2. Drummond Place.
- For the production of two undescribed ornamental plants (a new species of *Calceolaria*, and a new variety of *Rhododendron Catawbiense*),—to Mr William Macnab, superintendant of the Royal Botanic Garden, Edinburgh.
- For his remarkable success in cultivating the finer Cape Heaths, magnificent specimens of which have at different times been exhibited to the Society,—to Mr William Couper, gardener to George Dunbar, Esq. Rose Park, Trinity.

COMMITTEE MEETING, *June 30. 1823.*

The Committee unanimously agree in opinion, that the Secretary should write a letter to the Hon. the Barons of Exchequer, proposing that their Lordships should make the purchase of the ground for an Experimental Garden for the Crown, and should then grant a renewable lease to the Society; and they approved of the draft of a letter to that purpose, of which the following is a copy:

“ MY LORDS,

“ The Society for the Improvement of Horticulture in Scotland having been informed that the Lords Commissioners of his Majesty’s Treasury had been pleased to grant the prayer of their petition for the loan of the sum of £4000, at $3\frac{1}{2}$ per cent., for the purpose of purchasing a piece of ground, consisting of eight

acres, in the neighbourhood of this city, to be occupied as an Experimental Horticultural Garden, and that] a warrant has been issued for paying the same accordingly, I am desired by the Committee of Management for the Society, respectfully to submit to your Lordships' consideration a plan which appears to them more eligible than the original one of their making the purchase. They would, with great submission, suggest, that, in place of the money being paid over to them, upon their granting a bond for the repayment of the sum, and of the regular payment of the interest at the rate of $3\frac{1}{2}$ per cent. in order that the Society might purchase the ground,—the ground should be purchased by your Lordships, for behoof of the Crown, and that then a renewable lease should be granted to the Society for payment of a stipulated rent equal to the interest of the purchase-money at $3\frac{1}{2}$ per cent., and under all the conditions mentioned in the Royal Warrant for the money. This, with great deference, appears to the Society a more simple mode of obtaining the object, and certainly would afford a still better security to the Crown for the purchase. I am," &c.

(Signed) "PAT. NEILL, *Sec. Cal. Hort. Soc.*"

COMMITTEE MEETING, July 10. 1823.

To-day there was a very fine display of rare exotic plants in flower-pots, and also of the flowers of Scots Roses, the competition in these last having been delayed from 12th June, on account of the lateness of the season.

The medal for the four finest exotics was awarded to Mr William Macnab, superintendant of the Royal Botanic Garden. The plants were *Cactus speciosissimus*, in full flower; *Lilium Japonicum*, with two heads of flowers; *Fuchsia coccinea*, forming a shrub ten feet high, covered with blossoms; and *Cuscuta americana*, parasitical upon a plant of the garden balsam.

The Committee agreed in voting an extra medal to Mr

James Cuningham, Comely Bank, for several very fine Geraniums, and particularly for a very ornamental Seedling raised by him, and called Marchioness of Tweeddale.

The medal for the largest and finest collection of varieties of Scots Roses was voted to Messrs Dickson and Co. Leith Walk.

Messrs Charles and John Peacock having exhibited a very extensive and beautiful collection of 150 marked varieties of Garden Roses, including all the finer kinds, and also several sorts of Moss Roses,—double white, single red; Rose de Meaux mossed, &c.—the Committee unanimously concurred in voting an extra medal to Messrs Peacock.

COUNCIL MEETING, *August 7. 1823.*

Mr Ninian Lindsay, gardener to the Hon. Lord Hermand; sent, in compliance with a wish expressed by the Committee of Prizes, specimens of Carrots, Beets, Potatoes, and Jerusalem Artichokes, of the crop of last year 1822, preserved till this period in the mode formerly described by him, (earthed in a plantation where the soil was much exhausted). These specimens were considered as in a state of high preservation, and the silver medal was voted to Mr Lindsay.

GENERAL MEETING, *September 4. 1823.*

Upon a report from the Committee of Prizes, the silver medal was awarded as follows :

For the best Peaches from open walls (Red Magdalene and Early Mignonne), without artificial heat,—to Mr David Ford, gardener to the Right Hon. the Earl of Haddington, Tynningham.

The best Peaches from flued walls, without glass,—to

- Mr John Kyle, gardener to James Stirling, Esq. of Keir, Dunblane.
- The best Nectarines (Vermash) from flued walls,—also to Mr John Kyle.
- For Moorpark Apricots, two prizes,—one to Mr James Kirk, gardener to Lady Hepburn at Smeaton, and another to Mr Thomas Inglis, gardener to the Hon. Mrs Ramsay of Barnton.
- For the best six sorts of Plums,—to Mr John Kyle at Keir.
- The best Green Gages,—to Mr William Reid, gardener to Sir John Marjoribanks, Bart. of Lees, Coldstream.
- The best Gooseberries (large Green-onion Gooseberry), —to Mr James Morison, gardener to Captain Grant of Congalton.
- The best Pine-apples (Queen and New Providence), —to Mr Alexander Muirhead, gardener to Colonel Belshes of Invermay.
- The best Rock Cantelope Melon (Scarlet Cantelope), —also to Mr Alexander Muirhead.
- The finest Melon of any other variety (green-fleshed), —to Mr John Mitchell, gardener to Sir David Moncrieffe, Bart. Moncrieffe House.
- The finest bunches of the Gibraltar Grape,—to Mr James Macdonald, gardener to his Grace the Duke of Buccleuch and Queensberry, Dalkeith Park.
- The largest and finest bunches of the White Muscat of Alexandria,—to Mr William Wright, gardener to the Right Hon. the Earl of Rosebery, Dalmeny Park, Cramond.
- The largest Grapes of any other sort,—to Mr Duncan Macgregor, gardener at Hermitage Park.

The best Summer Apples; those from Dr Duncan's garden St Leonard's Hill.

For the greatest variety of Fruits of good quality, produced by any one competitor,—to Mr David Ford at Tynningham.

The finest Stage Carnations,—to Messrs Charles and John Peacock, Stanwell Lodge.

For very fine Seedling Dahlias, two prizes; one to Mr Alexander Forrester, gardener to David Falconar, Esq. of Carlowrie; and another to Mr William Henderson, gardener to Sir Alexander Muir Mackenzie, Bart. of Delvine.

The Committee unanimously recommended that extra medals should be awarded as follows:

For a basket of Grapes, of the finest kinds, and evidently cultivated in the first style of excellence,—to Mr Philip Shillinglaw, gardener to the Right Hon. the Earl of Kinnoul, Dupplin Castle.

For a rich assortment of Melons,—to Mr James Macdonald, Dalkeith Park.

For a new Seedling Melon of uncommon size and weight (21 lb. 12 oz.), and of good quality,—to Mr Thomas Inglis, Barnton.

For a Seedling Peach, of fine appearance and high promise, raised by Mr Robert Hosie, gardener to the Right Hon. Lord Lyndoch, Lyndoch House.

The Committee appointed to try the Home-made Wines reported, that a considerable variety of excellent wines was presented for competition, and that two kinds of wine approached each other so nearly in excellence, that they found it extremely difficult to decide which of them ought to be preferred. In this dilemma they proposed that a medal be given to each. On opening the letters, one of

these wines was found to have been sent by the Rev. Leslie Moodie, Inveresk ; the other by Miss Margaret Wright of Lawtown, near Perth.

The Committee further reported, that although only one specimen of Scottish Cider was presented to them, yet that this was so excellent, that, before opening the letter accompanying it, they unanimously agreed to request the Society to award their gold medal, that this may operate as an inducement to others (especially in seasons, like the last, when apples are abundant in Scotland) to undertake the manufacture of an extremely elegant, healthful, and cheap beverage. This having been agreed to, the sealed letter was opened, and the cider found to have been sent by Mrs Fotheringham of Fotheringham, and to have been made by her butler Mr Robert Petticrew.

COUNCIL AND COMMITTEE MEETING,
November 13. 1823.

It was agreed that the gold medal be awarded to Mr Francis George Probart of Lincolnshire, for his communication describing an economical mode of collecting Lettuce-Opium, or Lactucarium as it has been denominated.

The Council and Committee then made trial of sixteen different Seedling Apples, raised at Kinfauns by Mr William Campbell, gardener to Lord Gray. They highly approved of several of these, particularly one marked Campbell's Pippin ; another marked 10, a very red firm apple, excellent for orchards, &c. It was unanimously agreed that the silver medal should be voted to Mr Campbell at this time.

GENERAL MEETING, *December 4. 1823.*

The Committee for Prizes which met this day reported, that medals had been awarded as follows :

For the best three sorts of Apples which have been found to ripen well on standards or espaliers,—to Mr Alexander Forrester, gardener to David Falconar, Esq. of Carlowrie.

For the best Pears produced in Scotland,—to Mr James Macdonald, gardener to his Grace the Duke of Buccleuch and Queensberry at Dalkeith.

For the best Achan Pears,—to Mr James Stewart, gardener to Sir John Hope, Bart. of Pinkie.

For the best three bunches of retarded Grapes (Black Hamburgh, Syrian, and Muscat),—to Mr Daniel Sinclair, gardener to James Donaldson, Esq. of Broughton Hall.

The Committee farther reported, that they had thought it right to vote an extra medal for three uncommonly large and fine bunches of the Syrian Grape, sent to the meeting by Mr William Laidlaw, gardener to David Anderson, Esq. of Moredun.

GENERAL MEETING, *March* 11. 1824.

The report of the Committee of Prizes being called for, they reported, that a medal for the best six kinds of Apples from standards or espaliers, fit for the dessert at this season, was awarded to Mr John Gibb, Prestonkirk; and that the medal offered for the three finest specimens of Camellia in full flower, was due to Mr James Cuninghame, Comely Bank.

The Committee further reported, that excellent specimens of forced Rhubarb stalks had this day been received from Hopetoun-House Garden, with a distinct account of the mode of culture; and they unanimously recommended that, for this communication, an extra medal should be awarded to Mr James Smith, gardener to the Right Hon. the Earl of Hopetoun; which was agreed to.

COMMITTEE MEETING, *April 29.* 1824.

Having inspected a very respectable collection of Stage Auriculas, sent by six different competitors, the Committee determined that the medal was due to those exhibited by Mr Alexander Forrester, gardener to David Falconar, Esq. of Carlowrie, which were not only of excellent kinds, but particularly well grown. Some of the other collections evinced the increasing taste for the cultivation of this fine flower.

Several collections of Seedling Auriculas were also examined, and a medal voted to James Macdonald, Esq. Newington, for the best.

The prize for Stage Polyanthuses was unanimously awarded to Messrs Dickson and Co. Leith Walk Nurseries, who also produced the finest collection of Seedling Polyanthuses.

GENERAL MEETING, *June 10.* 1824.

The Committee for Prizes which had met this forenoon, reported,

1. That five different specimens of Early Melon had been sent for competition; that all of them were well grown, and evinced the skill of the cultivators; and that the medal had been awarded to Mr William Henderson, gardener to Sir Alexander Muir Mackenzie, Bart. of Delvine, for a specimen of the Green-fleshed Ionian.

2. That five different parcels of Early Potatoes had been sent, of different sorts, and raised on different principles; that the prize for the best, forwarded in a vinery, had been voted to Mr George Brown, gardener to the Right Hon. the Earl of Lauderdale, Dunbar House; and that the Committee recommended the awarding an extra medal to Mr Robert Fairbairn, Belton House, for a fine

specimen of Potatoes called the Adelphi Early, produced wholly in the open border.

3. That the premium for the best Ranunculuses had been voted to Messrs Dicksons and Co. Leith Walk Nurseries.

4. That two specimens of Dessert Apples of last year's crop were presented; and that the medal had been assigned for those preserved by Mr John Macnaughton, gardener to Colonel Wauchope of Edmondstone.

The Committee further reported, that a collection of some of the finest species and varieties of Pelargonium having been exhibited to the meeting this day, by Mr James Cunninghame, Comely Bank, together with a new and beautiful variety, marked No. 14., raised by him from the seed, they were of opinion that it would be proper to reward the zeal of this cultivator by voting him the silver medal; which they had accordingly done.

COUNCIL MEETING, *July 15. 1824.*

The Committee for Prizes reported,

1. That only two parcels of Exotic plants in flower had been presented to-day, and that they had voted the medal to Mr William Macnab, a new species of Fuchsia (*F. decussata*), raised at the Botanic Garden, appearing among his plants.

2. That Mr John Street, flower-gardener to the Hon. Mrs Hamilton Nisbet at Biel, had exhibited a large collection of specimens of exotic plants, partially naturalized by him at Biel, many of them being raised from seeds ripened in the open air in the same garden; and that the Committee judged it right to encourage the meritorious and persevering exertions of Mr Street, by again awarding to him an extra medal.

COUNCIL MEETING, *August 5. 1824.*

The Council and Committee made trial of seven sorts of Seedling Gooseberries, sent by Mr Duncan Macgregor at Hermitage. No. 4. was considered as excellent, and the others as good berries. The silver medal was voted to Mr Macgregor for these seedlings.

Having heard a report from Mr Andrew Dickson and the Secretary, as to a collection of specimens of Seedling Roses, raised at Kinfauns Garden, and sent by Mr William Campbell, gardener to Lord Gray, the silver medal was unanimously voted to Mr Campbell.

GENERAL MEETING, *September 2. 1824.*

The Committee on Home-made Wines, gave in the following report :

“ *1st September 1824.*

“ The Committee appointed to examine the Home-made Wines beg leave to report to the Society, that twenty-four different varieties were submitted to them. Among these, several were excellent, and approached so near to each other, that the Committee found it difficult to award the medal. The most perfect wine, however, appearing to them to be that marked ‘ No. 45.’ they adjudged the medal to Miss W. M. Johnstone, No. 27. James’s Square, whose sealed letter bore that mark.

“ The other excellent Wines were particularly the following: Five different kinds, with the motto “ *Se defendendo,*” made by the same person ; another with the motto, “ *If you don’t like it, don’t tell ;*” and another, with “ *All is not lost that’s in peril ;*” and the Committee beg leave to suggest, that it may be expedient to award a separate medal for each of these, not only as an encouragement to the competitors, but as an inducement to others to emulate their example, in cultivating the fruits of this country, and

manufacturing carefully the most perfect wines from our own fruits. The two last named wines are intended to imitate mousseux Champaign, and are excellent of their kind. The Committee would recommend, in a particular manner, to the Society, the encouragement of this kind of wine, as, by due care, a very palatable and wholesome beverage for summer use may easily be prepared, at a small expence.

“ If the Society shall approve of the suggestion of the Committee, the extra or additional medals should be given to Mrs W. H. Roberts, Kenleith Cottage, Currie, for the wines marked “ *Se defendendo* ;” to Mrs Stevenson, Broompark Cottage, Trinity, “ If you don’t like it, don’t tell ;” and to Mrs Mackinlay, Royal Terrace, “ All is not lost that’s in peril.”

“ In examining the other wines submitted to them, the Committee observed, that several of these were not fully fermented, and were much sweeter to the taste than wines intended for common use ought to be. This defect arises, in a great measure, from too great a quantity of sugar being originally dissolved in the currant or gooseberry juice and water,—from too much water being added to the juice of the fruit,—from too strong pressure of the fruit,—sometimes from too much water being added to the juice of the fruit,—and from the fermentation being prematurely stopped by the addition of alcohol. To remedy this, the Committee would suggest, that much less sugar (perhaps in many cases where the berries are well ripened and saccharine, only one-half of the quantity usually added) be employed,—that the proportion of juice be considerably increased,—and that no spirits be added until the following spring, and then, if any, not more than a quart to ten gallons.”

The Committee of Prizes gave in the following report :

“ The Committee for Prizes beg leave to report, that the quantity of Fruit sent in competition was as large as usual, and the quality in general very excellent, and that the prizes should be awarded as follows :

For the best Peaches from open walls, without artificial heat,—to Mr John Dick, gardener to William Trotter, Esq. of Ballendean.

The best Peaches from flued walls, without glass,—to Mr Thomas Inglis, gardener to the Hon. Mrs Ramsay of Barnton.

The best Nectarines from flued walls, without glass,—also to Mr Inglis.

The best Moorpark Apricots,—to A. M. Wellwood, Esq. of Pitliver, Dunfermline.

The best six sorts of Plums (Green Gages excepted), two prizes ; one to Mr James Arnot, gardener to James Moray, Esq. Abercairney ; and another to Mr Alexander Bisset, gardener to Colonel Smyth, Methven Castle.

The best Green Gage Plums,—to Mr Alexander Reid, gardener to the Right Hon. Lord Viscount Kelburne, Etal House.

The best retarded Gooseberries (Hutchison's late Warrington),—to Mr Alexander Stuart, gardener, Bonnington House.

The best Pine-Apple (Queen),—to Mr James Simpson, gardener to Captain Wemyss, M. P. Wemyss Castle.

The finest Rock Canteloup Melon,—to Mr Philip Shillinglaw, gardener to the Right Hon. the Earl of Kinnoul, Dupplin Castle.

The finest Melon of any other variety (Cephalonian),—to Mr George Brown, gardener to the Right Hon. the Earl of Lauderdale, Dunbar House.

The best specimen of the Gibraltar Grape,—to Mr William Wright, gardener to the Right Hon. the Earl of Rosebery, Dalmeny Park.

The two largest bunches of the White Muscat of Alexandria,—to Mr Adam Melrose, gardener to Sir Michael Shaw Stewart, Bart. Ardgowan.

The best Tokay Grape,—to Mr Daniel Sinclair, gardener to James Donaldson, Esq. Broughton Hall.

The largest bunches of Grapes of any other sort (White Nice, but called Tokay, one bunch weighing 48½ oz. the other 40 oz.)—to Mr John Webster, gardener to the Hon. General Maitland, Manderston.

The best six kinds of Summer Apples, two prizes; one to Mr James Macdonald, gardener to his Grace the Duke of Buccleuch, Dalkeith Park; and another to Mr Daniel Sinclair, gardener to James Donaldson, Esq. Broughton Hall.

For the greatest variety of Fruits of good quality,—to Mr John Macnaughton, gardener to Colonel Wauchope of Edmondstone.

“ The Committee further report, that the medal for the twelve finest Carnations is due to James Macdonald, Esq. Newington; and they recommend that an extra medal be awarded for a collection of Seedling Carnations presented by Mr Duncan Macgregor, gardener, Hermitage, Leith.

“ A specimen of *Nelumbium speciosum* in full flower, having been presented, and this being a rare and difficult production, they recommend that an extra medal be awarded to the cultivator, Mr Alexander Stewart, gardener to Sir Robert Preston, Bart. Valleyfield.

“ Excellent specimens of a variety of Onion, little known and seldom cultivated, called Flat Yellow, having been sent to the meeting, the Committee also recommend an extra medal for this production to Mr Robert Fairbairn, gardener to Captain Hay of Belton.”

COUNCIL MEETING, *November 11. 1824.*

Several collections of Seedling Apples were tried, and carefully compared. The Council were of opinion, that, in terms of the advertisement published last year, the gold medal ought now to be adjudged; and they found that it was due to Mr William Campbell, gardener at Kinfauns Castle, several of whose seedlings were both beautiful and excellent.

The attention of the Council was attracted by the good qualities of an Autumn Apple from Dysart, remarkable for its sweetness and delicate flavour, and agreed that the silver medal should be awarded to Mr Andrew Duncan, Dysart, who raised it.

The Secretary laid before the meeting a letter from John Traill Urquhart, Esq. accompanying some very fine and large specimens of Apples (particularly Manks Codlins), equal to any produced in the Lothians, produced in a new garden formed by him at Elsness, in the Island of Sanda, Orkney. The Committee voted to Mr Urquhart the Society's silver medal for thus promoting horticulture with success in the most northern parts of the British Islands.

GENERAL MEETING, *December 2. 1824.*

Dr Duncan read a discourse, announcing that the Council had awarded the annual gold medal, for the most important communication received during the year, to Mr William Macnab, for the Plan of the Experimental Garden then lying on the table.

The Committee for Prizes reported, that prizes this day ought to be awarded as follows:

For the best three sorts of Apples lately introduced, or not generally known, &c.—to Mr John Taylor, gardener to the Right Hon. the Earl of Dunmore, Dunmore Park.

For the best six Newton Pippins, the produce of Scotland,—to Mr David White, gardener to R. W. Ramsay, Esq. of Whitehill.

For the best Pears produced in Scotland, two prizes; 1st, To Mr John Taylor, Dunmore Park, among whose pears was an excellent seedling one, raised at Dunmore, between the Brown Beurré and Chaumontelle; 2d, To Mr James Stuart, gardener to Sir John Hope, Bart. of Pinkie.

For the best retarded Grapes, three prizes; 1st, To Mr Alexander Stewart, gardener to Sir Robert Preston, Bart. of Valleyfield, for very fine and large bunches of the Syrian Grape; 2d, To Mr Thomas Inglis, gardener to Mrs Ramsay of Barnton, for excellent Black Hamburgh Grapes; 3d, To Mr John Macnaughton, gardener to Colonel Wauchope of Edmondstone, for very fine Muscat of Alexandria Grapes, being the second crop, and from plants growing between the flues.

The Committee further reported, that an extra medal ought to be awarded to Mr George Brown, gardener to the Right Hon. the Earl of Lauderdale, Dunbar House, for excellent specimens sent to the meeting, of varieties of several culinary vegetables which are little known or cultivated in Scotland, particularly the turnip-rooted parsnip, the celeriac, the knol-kohl, and the Guernsey potato.

COUNCIL MEETING, *December 9. 1824.*

The Council having considered a certificate by Lady Elizabeth Moncrieffe, and also a letter from Sir David Moncrieffe, Bart. bearing testimony to the faithful services

of Mr John Mitchell, as head-gardener at Moncrieffe House for a period of more than thirty-two years, he having at the same time practised all the branches of gardening; and having learned from the Secretary that it was only in consequence of an accidental occurrence that Lady Elizabeth Moncreiffe's certificate had not been laid before the meeting on the 2d instant, unanimously agree in voting to Mr Mitchell the silver medal offered for long and faithful service for this year.

COUNCIL MEETING, *February 3. 1825.*

The Secretary laid before the meeting a letter from Mr John Dick, gardener at Ballendean, communicated by William Trotter, Esq. regarding an improved fruit-wall hammer. The Council considering this hammer (calculated, by means of a projecting guard, to save the twigs of peach-trees, in drawing nails in any direction), as a real, though simple improvement, agree to recommend to the Society to award to Mr Dick the silver medal for it.

GENERAL MEETING, *March 10. 1825.*

The Committee for Prizes which met this day reported that premiums were awarded as follows:

For the best six crowns of Sea-cale,—to Mr James Smith, gardener to the Right Hon. the Earl of Hopetoun, Hopetoun House. No fewer than eight other competitors in this article appeared, and all the specimens produced were well grown and well blanched; proving the increased cultivation of sea-cale, and increased attention to its proper culture.

For the three finest specimens of Camellia in full flowers, three different varieties,—to Messrs Dicksons and Company, Leith Walk Nurseries.

For the five finest specimens of *Erica*, different species, —to Mr John Barclay, gardener to George Dunbar, Esq. Rose Park.

For the three finest and rarest specimens of Exotic plants in flower (exclusive of the genera *Camellia* and *Erica*),—to Mr William Macnab, superintendent of the Royal Botanic Garden.

For the greatest variety of spring flowers produced in the open border (exclusive of *Anemones*);—to Mr Alexander Forrester, gardener to David Falconar, Esq. of Carlowrie.

For the best six single *Anemones* from the open border,—to Mr Robert Lees, gardener to Miss Scott, Mount Lodge, Portobello.

The Committee also recommended that an extra medal should be awarded to Mr James Stuart, gardener to Sir John Hope, Bart. of Pinkie, for excellent specimens of *Rhubarb*-stalks, forced in the open ground by means of tree-leaves and stable-litter, in the manner of sea-cale; and also an extra medal to Mr John Street, flower-gardener to the Hon. Mrs Hamilton Nisbet of Biel, for a new mode of growing various plants and cuttings in moss or hypnum, the advantages of which consist in rendering the plants at once less liable to injury from overwatering, and also less susceptible of harm from water being neglected; and in making them more fit for sending to great distances, the balls of moss, penetrated by the fibrous roots, remaining quite entire.

COMMITTEE MEETING, *April 28. 1825.*

The Committee proceeded to the examination of the collections of *Auriculas* and *Polyanthuses*, both stage plants and seedlings, produced in competition. They found that

the medal for Stage Auriculas was due for the flowers found to be sent by James Macdonald, Esq. Newington ; and that a medal for Seedling Auriculas was merited by a parcel of fine seedlings, which were found to be sent also by Mr Macdonald. For Stage Polyanthuses they awarded the prize to Messrs Dicksons and Company, Leith Walk Nurseries ; and they voted a medal for a parcel of Seedling Polyanthuses found to be raised by Mr Charles Doig, gardener at Middleton House.

GENERAL MEETING, *June 9. 1825.*

The Committee for prizes which met this day reported, that the Society's silver medal offered for the " best Early Melon, with an account of the mode of culture, and the history of the variety," was due to Mr John Middleton, gardener to Archibald Campbell, Esq. of Blythwood, by Renfrew ; and that the medal offered for the " best double Stock" was due to Mr Alexander Dow, gardener to James Wyld, Esq. Bonnington Bank.

GENERAL MEETING, *September 1. 1825.*

The report of the Fruit Committee having been called for, the following was given in, read, and approved of :

" *31st August 1825.*

" The Committee having carefully examined the specimens of Fruit sent in competition, beg leave to report, that premiums should be awarded as follows :

For the greatest variety of Peaches from open walls (Royal George, Noblesse, and Newton),—to Mr Robert Lees, gardener to Miss Scott, Mount Lodge, Portobello.

The best twelve Moorpark Apricots,—to Mr James Smith, gardener to the Right Hon. the Earl of Hopetoun, Hopetoun House.

- The greatest variety of Plums, Green Gages excepted, (Sharpe's Emperor, Imperial, Red Magnum, White Magnum, and Myrobalan),—to Mr Alexander Smith, gardener to George Paterson, Esq. of Cunoquhie.
- The best Green Gages, two dozen,—to Mr William Reid, gardener to Sir John Marjoribanks, Bart. of Lees.
- The best Scots pint of retarded Gooseberries,—to Mr William Affleck, gardener to Thomas G. Wright, Esq. Duddingston Cottage.
- The best Queen Pine-apple,—to Mr John Mitchell, gardener to Sir David Moncreiffe, Bart. Moncreiffe House.
- For a Seedling Pine-apple of good quality, an extra medal,—to Mr Howe, gardener to the Right Hon. Lord Duncan, Camperdown, Dundee.
- The greatest variety of Melons, with their names, &c. —to Mr Thomas Inglis, gardener to the Hon. Mrs Ramsay of Barnton.
- For the best three bunches of White Frontignac Grapes, —to Mr George Munro, gardener to William Hay, Esq. Dunse Castle.
- The two largest and heaviest bunches of White Muscat of Alexandria,—to Mr James Macdonald, gardener to his Grace the Duke of Buccleuch and Queensberry, Dalkeith Park.
- The largest Grapes of any other sort (the Black Gibraltar), two bunches,—also to Mr Macdonald.
- For uncommonly fine Black Hamburgh Grapes, an extra medal,—to Mr Philip Shillinglaw, gardener to the Right Honourable the Earl of Kinnoul, Dupplin Castle.

The best six kinds of Apples, a dozen of each kind,—
to Mr Daniel Sinclair, gardener to James Donaldson, Esq. Broughton Hall.

For a variety of fine Summer Apples, an extra medal,
—to Mr Alexander Bisset, gardener to Colonel Smyth, Methven Castle.

For excellent retarded Mayduke Cherries,—to Mr John Macnaughton, gardener to Colonel Wauchope of Edmonstone.

For the greatest variety of Fruits of good quality, produced by any one competitor,—to Mr Robert Ingram, gardener to Sir John Erskine, Bart. of Torrie.”

The report of the Committee on Home-made Wines having been called for, the following was given in, read, and approved of :

“ 31st August 1825.

“ The Wine Committee report to the Society, That the medals distributed in former years seem to have induced a greater number of competitors than usual to come forward ; no less than thirty-seven different varieties of wine having been presented to them for examination. The quality of the wines, too, seems to be improving materially, from year to year, not only in the champaign, both still and mousseux, from the unripe gooseberry, becoming more and more palatable ; but various attempts at imitating the drier Continental wines have succeeded beyond expectation. On this account, although they are compelled, from the superiority of the wine, to award the first prize to that marked “ Take a bumper, and try,” found to belong to Mrs Roberts, Kenleith Cottage, being in their opinion the best wine ; yet they cannot resist recommending to the Society to award an extra medal to Mrs Galt, Inveresk, for not only having produced very excellent gooseberry wine

but also four others, all superior in their kind, particularly one marked "Avignon;"—another extra medal for a wine marked "Practice makes Perfection," being the most palatable currant wine, and found to belong to Mrs Mackinlay, Royal Terrace; and likewise an extra medal for the wine marked "Bathurst Plains," being perhaps the best dry home-made wine that has ever been presented, and found to belong to Miss Jameson, 21. Royal Circus.

"The Committee cannot avoid stating, that a very excellent wine was presented to them for competition, from the neighbourhood of Hull, to which, as it was not the produce of this country, they could not award a medal, which they regret exceedingly.

"Upon the whole, the Committee are of opinion, that the wines produced upon this occasion are considerably superior to those of former years, and that the public will derive benefit from the Society continuing to hold forth the same rewards for excellence of manufacture which it has hitherto done.

"The Committee beg again to suggest, that a much smaller quantity of sugar ought to be added to the fruit than is generally done. And they cannot conclude without strongly recommending strongly to future competitors, to follow, as nearly as they can, the mode adopted by Mrs Roberts of Kenleith Cottage, who seems, from the specimens of five sorts of wine produced by her for competition, to have established a method of preparing, upon scientific principles, a perfect wine of most excellent quality; the receipt and method of preparing which, may be seen in the Memoirs of the Society, No. XII. (Vol. III. p. 460.)"

COUNCIL MEETING, *November 10. 1825.*

A collection of fine Pears, from the garden at Buchanan

House, was examined and tried ; and the size and excellence of the specimens of Gansell's Bergamot were such, that the meeting considered it right to award an extra medal of encouragement to Mr D. Montgomerie, the gardener there, with a vote of thanks for his promise of grafts, &c. to the Experimental Garden.

COUNCIL MEETING, *December 1. 1825.*

The Council having examined the different certificates produced this year by head-gardeners, who have served for long periods the same family, and exercised all the branches of the profession, to the satisfaction of their employers, found that the medal is due to Mr Thomas Pattison, head-gardener for forty-eight years to W. F. Campbell, Esq. of Islay, in the garden in that island.

GENERAL MEETING, *December 1. 1825.*

The following report was given in by the Committee of Prizes, and approved of :

“ The Committee report, that the prizes should this day be awarded as follows :

For the best three sorts of Apples, lately introduced, or not generally known in Scotland, and which have been found to ripen well on standards or espaliers, at least two of each sort, with an account of the state of the trees, &c. Two parcels being judged equal in merit, the Committee recommend the awarding of two prizes ; one to Mr Thomas Inglis, gardener to Mrs Ramsay of Barnton ; and another to Mr James Simpson, gardener to Captain Wemyss at Wemyss Castle.

For the best Pears produced in Scotland, three specimens of each kind,—to Mr John Macnaughton,

gardener to John Wauchope, Esq. of Edmondstone.

For the best three bunches of retarded Grapes, with an account of the mode of retarding, and of the kinds best calculated for keeping,—to Mr John Clephane, gardener to John Balfour, Esq. Hailes.

For the best swelled specimens of Celeriac, three roots to be produced, with an account of the mode of culture,—to Mr George Brown, gardener to the Right Hon. the Earl of Lauderdale, Dunbar House.

For the best three stems of Blanched Cardoons,—to Mr Thomas Liddel, gardener to the Hon. General Duff, East Warriston.

For the greatest number of distinct varieties of *Chrysanthemum Indicum* in flower. There being two parcels, containing twenty varieties each, the Committee recommend the awarding a premium for each of these collections; and the sealed letters being opened, one was found to belong to Mr William Macnab of the Royal Botanic Garden, Inverleith; and the other to belong to Mr Alexander Stewart, gardener to Sir Robert Preston, Bart. of Valleyfield, near Culross."

GENERAL MEETING, *March 2. 1826.*

The Committee for Prizes gave in the following report:

“ *2d March 1826.*

“ The Committee met this day, and beg leave to report, that medals should be awarded as follows:

For the best Scots pint of Mushrooms, with an account of the mode of cultivation,—to Mr James Dods, gardener to John Warrender, Esq of Lochend House, Dunbar.

An extra medal for a remarkable variety, the pileus having large scales pencilled with hair-brown lines, and the whole plant being very fleshy and tender,—to Mr William Reid, gardener to Sir John Marjoribanks, Bart. of Lees.

For the best twenty-five forced Strawberries (Roseberry variety),—to Mr Malcolm Carmichael, gardener, at Raehills, to John Hope Johnstone, Esq. of Annandale.

For the best Apples, three sorts, three specimens of each,—to Mr William Oliver, gardener to the Right Hon. the Earl of Rosslyn, Dysart.

An extra medal to Mr George Brown, gardener to the Right Hon. the Earl of Lauderdale, Dunbar House, for several remarkably fine Apples, of kinds little known here, the trees having been imported from France.

For very excellent specimens of Camellia in full flower, six different varieties in flower-pots,—to Mr John Barclay, gardener to George Dunbar, Esq. Rose Park, Trinity.

An extra medal for a beautiful seedling Camellia,—to Mr James Cunningham, botanical nurseryman at Comely Bank.

For the five finest specimens of Erica, different species,—to Mr William Macnab, superintendent of the Royal Botanic Garden, Inverleith.

For the best six Hyacinths, in pots or glasses, red blue, or white, two of each,—to Mr Robert Reid, gardener to Sir Alexander Keith at Ravelstone.

COUNCIL MEETING, *April 6. 1826.*

A prize having been offered for the greatest variety of Crocus produced to the meeting this day, two collections

were examined ; one containing 80 varieties, and the other 72. The medal was voted to the former, which was found to belong to Messrs Dicksons and Co. Leith Walk. The meeting regretted to find that in neither collection were the *species* distinguished.

COMMITTEE MEETING, *April 20. 1826.*

The Committee regretted to find, that the number of competitors or exhibitors, either in Auriculas or Polyanthuses, was less than in some former years.

They agreed, that a medal for very admirable Stage Auriculas should be awarded to those marked,

“ Nor fame I slight, nor for her favours call ;

“ She comes unlooked for, if she comes at all ;”

which were found to belong to Thomas Oliver, Esq. Burntsfield Links. They likewise agreed that a medal for Seedling Auriculas should be awarded to Mr David Anderson, 6. Brown Street ; but that it should be marked in the minutes that some very excellent seedlings were produced by James Macdonald, Esq. Newington, which could not be placed in competition, on account of Mr Macdonald having gained the prize for seedling auriculas last year.

The Committee voted a medal for Stage Polyanthuses to Mr Alexander Forrester, gardener to David Falconar, Esq. of Carlowrie ; and a medal for Seedling Polyanthuses to James Macdonald, Esq. Newington. The Committee desired it to be marked, that some excellent Stage Polyanthuses (believed to have been sent by Mr Hatelie) were necessarily excluded from competition, on account of the regulations not having been complied with.

The Committee having examined a number of varieties of *Polyanthus-Narcissus*, flowered in the open border at Biel, and also several seedlings of that flower likewise raised at Biel, were of opinion, that, although it would be irregu-

lar in them, as a Committee, to vote a medal for a production not announced in the prize-list, yet that Mr John Street, gardener at Biel, deserves some remuneration for the great trouble he had taken in this matter, and therefore agreed to recommend that the sum of one guinea be paid to him by the Treasurer of the Society.

GENERAL MEETING, *June 1. 1826.*

The report of the Committee of Prizes for this day having been called for, was given in and read as follows :

“ The best Early Melon in competition was a Rock Cantelope ; and on opening the sealed letter, it was found to have been raised by Mr John Macnaughton, gardener to John Wauchope, Esq. of Edmonstone, the seed sown 1st March in small pots ; kept in the pine pit fifteen days ; transplanted 16th March in the two-light pit frame formerly described to the Society ; the soil, two parts brown turf mould, one part strong clay, one part rotten dung, one part pit sand, all well mixed.

“ Two parcels of Grapes were regarded as so nearly equal in merit, that the Committee felt it necessary to award two medals ; 1st, For Black Hamburgh Grapes, found to belong to Mr Thomas Inglis, gardener to the Hon. Mrs Ramsay of Barnton ; 2d, For Frontignac Grapes found to have been sent by Mr Robert Reid, gardener to Sir Alexander Keith of Ravelstone.

“ Several baskets of Early Peas appeared, and all of them were of excellent quality. The basket selected as the best were of the early frame kind, and found to have been raised by Mr James Arklie, gardener to William Grant, Esq. of Congalton. They were sown 26th October at the bottom of a south 'aspected wall, with a little light vegetable mould over them in the drill ; covered with a few spruce branches in the time of hard frost, and kept

close up to the wall with straw ropes. Two pecks were pulled on the 18th May for the Lord High Commissioner's table, being the first produced.

“ The Secretary stated that he had received a letter from Mr Alexander Bisset, gardener to Colonel Smyth of Methven, describing a mode of forwarding early Peas, which had been practised by him for several years past. In January he sows them on pieces of old sward-turf reversed, 9 or 10 inches long, by 5 or 6 broad; places the turfs in a slight hot-bed, and in the middle of March plants out the entire turfs, loaded with the young pea plants, 4 or 5 inches high. The Committee examined a box of Nash's early frame peas so raised, and found them riper than any sent in competition, evincing that they had been ready for table more than a fortnight ago, as stated in Mr Bisset's letter. Regarding this practice as a meritorious improvement, the Committee unanimously voted an extra medal, and desired the Secretary to request Mr Bisset to make it public through the medium of the Society's Memoirs.

“ Several parcels of Early Potatoes, raised without artificial heat, were examined. The largest and finest were found to belong to Mr Inglis at Barnton, to whom the medal was accordingly adjudged.

“ Several competitors in double Anemones appeared. The best flowers were found to have been sent by Mr William Milne, gardener to Gilbert Innes, Esq. of Drum.”

COUNCIL MEETING, *June 15. 1826.*

The Secretary having read to the Meeting a report by Mr Andrew Dickson and Mr John Hay, relative to the Frame for preserving wall-trees, invented by Mr John Dick, gardener to William Trotter, Esq. of Ballendean, and a model of which was sent to the Society some time ago; and said report being highly favourable, they unani-

mously voted the Society's silver medal to Mr Dick, and direct that the frame be erected against a wall in the Garden, so as to be properly seen by the members.

Having heard a report from the meeting of Garden Committee, held on 8th June current, relative to some remarkable clusters of cultivated Mushrooms sent from Pinkie House, and having also considered the merit of Mr James Stewart, the gardener there, in introducing the forcing and blanching of Rhubarb-stalks in the open ground in the manner of sea-kale, the Council unanimously agree that the Society's silver medal be again awarded to Mr Stewart, and that he be requested to allow an account of his practice of forcing and blanching Rhubarb to be printed in the Memoirs.

GENERAL MEETING, *July 6. 1826.*

The following report from the Committee of Prizes, which met this day, was given in, read, and approved of:

“ The Committee having carefully examined the articles presented in competition this day, report, that the Society's silver medal should be awarded as follows :

For the best eighteen Pinks,—to Thomas Oliver, Esq. Burntsfield Place ; with a request that he would be so good as furnish a plant of each sort, with its name, for the use of the Experimental Garden.

For the best three Scots pints of Keen's new Seedling Strawberry,—to Mr James Arklie, gardener to William Grant, Esq. of Congalton.

For the best three Scots pints of Strawberries, three sorts, with their names,—to Mr James Bishop, gardener to George Mercer, Esq. Dryden by Lasswade. (The sorts were Roseberry, Methven Scarlet, and Bath Pine.)

For the best Scots pint of any other Strawberry not

generally cultivated,—to Mr James Simpson, gardener to James Wemyss, Esq. M. P. Wemyss Castle. (The kind was Keen's Imperial Pine.)

For the best Cherries, three sorts, thirty of each, with their names,—to Mr John Macnaughton, gardener to John Wauchope, Esq. of Edmonstone.

GENERAL MEETING, *September 7. 1826.*

The report of the Fruit Committee, which met yesterday, was given in and read as follows:

“ *6th September 1826.*

“ The Committee, after a very careful inspection and trial, which occupied more than four hours, beg leave to report, that prizes should be awarded as follows:

For the greatest variety of Peaches (11 sorts), from open walls,—to Mr John Dick, gardener to the Right Hon. the Lord Provost at Ballendean, Inchture.

For the greatest variety of Peaches (12 sorts), from flued walls,—to Mr Thomas Inglis, gardener to the Hon. Mrs Ramsay at Barnton, Edinburgh.

For the greatest variety of Nectarines (10 sorts), from flued walls, but without any fire this season,—to Mr George Shiells, gardener to the Right Hon. Lord Blantyre, Erskine House.

For the greatest variety of Plums (6 sorts), Green Gages excepted,—to Mr James Arnott, gardener to James Murray, Esq. Abercairney, Crieff.

For the best six Green Gages,—to Mr John Hamilton, gardener to A. Compton, Esq. Carham Hall, Coldstream.

For the best six sorts of Summer Pears (Jargonelles excepted),—to Mr James Stewart, gardener to Sir John Hope, Bart. of Pinkie.

- For the best six Jargonelle Pears,—to Mr William Oliver, gardener to the Right. Hon. the Earl of Roslyn, Dysart.
- For Queen Pine-apples, two prizes ; one to Mr Malcolm Carmichael, gardener to J. J. Hope Johnstone, Esq. of Annandale, Raehills, by Moffat ; and another to Mr Phillip Shillinglaw, gardener to the Right Hon. the Earl of Kinnoul, Dupplin Castle, Perth.
- For an excellent Enville Pine-apple,—to Mr James Young, gardener to John Richardson, Esq. of Pitfour, Perth.
- For a Lemon Antigua Pine-apple,—to Mr Alexander Muirhead, gardener to Colonel Belshes of Invermay, Bridge of Earne.
- For the largest Rock Melon,—to Mr James Macdonald, gardener to His Grace the Duke of Buccleuch at Dalkeith.
- For the largest Green-fleshed Melon,—to Mr James Stewart, gardener at Pinkie House, Musselburgh.
- For the best three bunches of White Frontignac Grape,—to Mr William Oliver, gardener at Dysart House, Dysart.
- For the two largest and heaviest bunches of White Muscat of Alexandria Grape,—to Mr John Macnaughton, gardener to Colonel Wauchope of Edmondstone.
- For the largest and best swelled Grapes in general (Black Damascus),—to Mr Thomas Berry, gardener to P. G. Skene, Esq. of Pitlour, by Auchtermuchty.
- For the largest and heaviest bunches of Black Hamburgh Grapes—to Mr Henry Frisel, gardener to John Veitch, Esq. of Olive Bank, by Musselburgh.

For the best two sorts of Figs (Brown and Black Ischia),—to Mr William Pearson, gardener to the Countess-Dowager of Hopetoun, Ormiston Hall, Tranent.

For the best six kinds of Summer Apples,—to Mr Alexander Bisset, gardener to Colonel Smyth of Methven Castle, by Perth.

For the greatest variety of different Fruits of good quality, produced by any one competitor (four sorts Peaches, six sorts Nectarines, six sorts Plums, four sorts Grapes, two Melons, twenty sorts Apples, and ten sorts Pears; in all fifty-two varieties of fruit),—to Mr James Arnott, gardener at Abercainey, by Crieff.

“ The fruit was in general of excellent quality, and afforded abundant evidence of the attention now paid to the higher branches of horticulture in this country. The Committee regret that they were obliged to pass over several excellent specimens, in consequence of the competitors not complying with the rules of competition laid down and published, a strict adherence to which they have learned by experience is absolutely necessary. In particular, in this way, a most admirable display of apples from the Lord Provost’s garden at Ballendean, was unavoidably excluded from competition.

“ Owing to the forwardness of the season, no Apricots nor Retarded Gooseberries could be expected at this meeting; but several members of the Garden Committee, and of the Committee of Prizes, having concurred in stating, that a parcel of the largest and finest Moorpark Apricots they had ever seen had been presented about three weeks ago, it was agreed to recommend that a medal be awarded to Mr Alexander Wilson, gardener to Sir Hew Dalrymple Hamilton, Bart. at North Berwick House, who sent them.

“ The Committee have now the satisfaction to add some pleasing proofs of the advancement of horticultural improvement in the production, at this meeting, of two Seedling Peaches, a Seedling Grape-vine, two Seedling Apples, and a Seedling Pear. The Seedling Peaches were presented to the Committee by the Hon. Sir Alexander Hope, Bart. of Luffness, personally: he stated that they had been raised at the garden of his nephew the Earl of Hopetoun, by Mr James Smith, the gardener at Hopetoun House. One of the sorts (marked No. 4) was regarded as being of most excellent quality; and the Committee unanimously recommend that an extra medal be awarded to Mr Smith for this production, with a request that he will furnish the history of it, and communicate cuttings for the Experimental Garden. The bunch of Seedling Grape was likewise regarded as of very superior quality; and the Committee were equally unanimous in recommending the awarding of an extra medal for it to Mr James Simpson, gardener to James Wemyss, Esq. M. P. Wemyss Castle, with a request that the Experimental Garden may be supplied with cuttings, when a glazed house shall be ready. The Seedling Apples were communicated by Mr George Bell of Leith, and Mr Finlay of Milfield; and the Seedling Pear was from Ormiston Hall Garden. But on the merit of these apples and the pear the Committee delayed deciding, till farther particulars of their age and history should be learned.

“ The culture of the Tomato or Love-apple in Scotland seems to the Committee to deserve encouragement; and six distinct varieties raised at Kennet Garden, and ripened in the open air, being produced to the meeting, the Committee recommend the awarding an extra medal to Mr Peter Barnet, gardener to Robert Bruce, Esq. of Kennet, for his success in this branch of culture.

The report of the Wine Committee, which met yesterday, being then called for, was given in and read as follows :

“ 6th September 1826.

“ The Wine Committee beg leave to report, That although the number of competitors for the prize medal is this year considerably less than it has been for some years past, yet that several of the Wines produced are excellent of their kinds, and at least equal to most of those formerly brought forward in competition. That which particularly attracted notice, and to which they consider the medal is due, is marked “ Melville Island ;” the same competitor producing another excellently prepared wine, marked “ Caucasus.” On opening the accompanying sealed letter, the Committee found, that the Melville Island Wine was prepared of White Currants and Refined Sugar, without spirits ; and the Caucasus Wine from a combination of White Currants and Raspberries ; by Mrs Patrick Torrie, Royal Circus, Edinburgh.

“ The Committee have also to report, that a Liqueur, prepared from Geans and Cherries, in imitation of the Swiss Kirschen-wasser, at Traquhair House, and transmitted to the Society by Lord Linton, through the hands of Old Provost Henderson, was this day produced ; and although no medal has been offered for Distilled Liqueurs, yet they beg leave to recommend that an extra medal be presented for this liqueur, to shew the anxious desire of the Society to encourage every manufacture connected with the produce of the garden.”

The Secretary then read a communication from Mr George Shiells, gardener to the Right Hon. Lord Blyth, Erskine House. Mr Shiells, finding that the Black Damascus Grape did not *set* freely, took some bunches of

the flowers of the Royal Muscadine, a free setting kind, and of which he had flowers to spare, and dusted the pollen over the flowers of the Black Damascus, about eight days after these had expanded, and when the stigmata seemed crowned with globules. Those bunches of the Black Damascus so treated, set very freely; while those not dusted with the Muscadine pollen, set only a few berries in each bunch. Specimens of bunches of both kinds were presented at the meeting. The meeting, regarding this practice, whether altogether original or not, as deserving of attention and encouragement, unanimously voted an extra medal to Mr Shiells; whose letter further proved that the practice was, on his part, the result of his own judgment and reflection.

COUNCIL AND COMMITTEE MEETING,
October 5. 1826.

Specimens of the third crop of a Seedling Pear, raised from the Green-yair impregnated with the Christie, were presented by Mr John Edwards at Luncarty. Considering the remarkable drought which has prevailed, the fruit was of considerable size; and although not a first rate pear, possessed an agreeable juice and flavour. The Council and Committee, anxious to encourage the production of new pears, agree that the silver medal be awarded to Mr Edwards for raising this Pear.

COMMITTEE MEETING, *October 26. 1826.*

A box of Seedling Apples raised, at Coull by Sir G. S. Mackenzie, was examined. No. 1., called the Tarvey Codlin (cross between the Manks Codlin and Nonpareil) was considered a very good and well-flavoured apple, but soft in the pulp. No. 2. the Kinellan, a beautiful fruit, of same parentage, was regarded as more juicy, but not so

highly flavoured as No. 1. No. 3. the Contin Rennet, considerably resembling the Nonpareil, and altogether an excellent apple. No. 4. Coul Blush Apple, a pretty fruit, but the specimens had been too long on the tree, and it was considered as not likely to prove a good keeper. Upon the whole, the Committee are of opinion, that all these four seedlings are well deserving of cultivation, and direct the Secretary to request of Sir George Mackenzie to favour the Society with grafts for the Experimental Garden; but they particularly recommend Nos. 1. and 3. as two of the finest seedlings that have yet been submitted to them. They unanimously recommend that the Society's honorary silver medal be presented to Sir George Stuart Mackenzie, Bart. for these meritorious productions.

WARRANT

FOR

A ROYAL CHARTER.

OUR SOVEREIGN LORD, considering that an humble Petition hath been presented to His Majesty, in the name of His Grace ALEXANDER, DUKE of GORDON, President of the Caledonian Horticultural Society; ANDREW DUNCAN, Doctor of Medicine; JAMES HOME, Doctor of Medicine; JOHN ARCHIBALD MURRAY, Esq. Advocate; Sir JOHN HAY, Bart. of Haystone and Smithfield, Vice-Presidents: and HENRY JARDINE, Esq. of Harwood; ROBERT GRAHAM, Doctor of Medicine, Regius Professor of Botany in the University of Edinburgh; HENRY COCKBURN, Esq. Advocate; The Rev. Dr ALEXANDER BRUNTON, Professor of Oriental Languages in the University of Edinburgh; THOMAS CRANSTOUN, Esq. of Dewar; and GEORGE BELL, Esq. Surgeon in Edinburgh, Council; ANDREW DICKSON, Esq. Treasurer; and PATRICK NEILL, Esq. Secretary of the said Society, for themselves, and the other constituent members of the said Society, setting forth, THAT, in the year 1809, the petitioners had formed themselves into a Society for the Improvement of Horticulture, in all its branches: That their exertions had been productive of great benefit to the public: That having raised a considerable sum of money, as the

commencement of a fund for promoting that useful purpose, and having already received a distinguished mark of His Majesty's Royal Bounty, by a grant of a lease of ground for an Experimental Garden, in the neighbourhood of the metropolis of Scotland, they trusted that the object they had in view would still farther be deemed worthy of His Majesty's Royal Patronage and Protection. The petitioners, therefore, humbly beseeched His Majesty to grant them a Royal Patent or Charter, for incorporating them, and such other persons as might afterwards be admitted members, into one body politic and corporate, for the purpose of the better management and security of their funds, under the title of THE CALEDONIAN HORTICULTURAL SOCIETY. The petitioners therefore prayed, That His Majesty might be pleased to grant a Charter, incorporating the petitioners, with such other persons as shall be admitted members, into a body corporate and politic, by the name and title above mentioned, with perpetual endurance and succession, with powers to use a common seal, to sue and to be sued, purchase and enjoy property, real and personal, to make and frame by-laws for the government of the said Society, and with all other necessary and usual powers and privileges. And His Majesty being satisfied that the design of the petitioners is laudable, and being desirous of promoting such improvement, does therefore ordain a charter to be passed and expedé under the seal appointed by the Treaty of Union to be kept in Scotland in place of the Great Seal formerly used there, constituting, erecting, and incorporating, as His Majesty, by his Prerogative royal, and special grace, for himself and his royal successors, hereby constitutes and incorporates the said petitioners, and the other persons who have already been admitted members of the said Society, and such persons as shall hereafter be admitted members thereof, agreeably to the rules of the

said Society, into one body corporate and politic, by the name of **THE CALEDONIAN HORTICULTURAL SOCIETY**, under which name they shall have perpetual succession, and a Common Seal; and they, and their successors under the same name, shall be legally entitled, and capable to purchase and enjoy lands, tenements, and any other heritage in Scotland, not exceeding the yearly value of One Thousand Pounds Sterling, and to lend such sum or sums of money to any person or persons, and upon such security, as they shall think fit, and to hold goods and chattels, and to receive and to hold donative for the purpose aforesaid: Declaring, that all charters, dispositions, and heritable securities, or other deeds affecting heritable property, to be granted to the said Society, shall be taken to it in its corporate name, that is, to “The Caledonian Horticultural Society,” without specifying the names either of the Presidents, or any of the Office-bearers or Constituent Members of the said Society; and that any charters, dispositions, or other deeds to be granted by the said Society, shall be subscribed by one of the Vice-Presidents and the Secretary for the time being (who, along with the office-bearers of the said Society, shall be appointed, in terms of the by-laws and regulations thereof), after having obtained the consent of a quarterly meeting of said Society, such consent being entered in the minutes of sederunt of such meeting, and that all deeds so subscribed shall be equally valid and sufficient, as if the same had been signed by the whole constituent members of said Society; and, by the name and title aforesaid, to sue and be sued in all or any of His Majesty’s Courts of Judicature,—and to have and use a common seal, and the same to change from time to time, as to the said Society shall seem expedient, and to make such by-laws, rules, and regulations, consistent with the laws of this realm, as may

best conduce to the foresaid purpose, and generally all other matters and things tending to forward the object of the said Society aforesaid, to do and execute, as fully and amply in every respect as any body corporate lawfully may do, and as if the said matters and things were herein particularly set down: And for better accomplishing the ends foresaid, and for the better making and establishing a continual succession of fit persons for managing the affairs of the said Society, His Majesty hereby wills, ordains, and appoints, that, for the better rule and government of the said Society, and for the better direction, management, and execution of the business and concerns thereof, there shall be thenceforth for ever a President, four Vice-Presidents, twelve Councillors, any three of whom shall be a quorum, for the purposes after mentioned; a Secretary, and a Treasurer of the said Society; to be elected in manner after mentioned: And we do hereby nominate and appoint ALEXANDER, DUKE of GORDON, first President; Dr ANDREW DUNCAN senior, JAMES HOME, JOHN ARCHIBALD MURRAY, and Sir JOHN HAY, first Vice-Presidents; HENRY JARDINE, ROBERT GRAHAM, HENRY COCKBURN, The Reverend ALEXANDER BRUNTON, THOMAS CRANSTOUN, GEORGE BELL, ALEXANDER HENDERSON, JAMES DICKSON, JAMES MACDONALD, JOHN SHANKLIE, JAMES STUART, and THOMAS INGLIS, first Council; PATRICK NEILL, first Secretary; and ANDREW DICKSON, first Treasurer. And it is His Majesty's further will and pleasure, that the members of the said Society, or any twelve or more of them, shall and may, on the first Thursday of December one thousand eight hundred and twenty-four, and also shall and may, on the first Thursday of December in every succeeding year, assemble together, at the then last, or other usual place of meeting of the said Society, and proceed to put out and

remove any two members who shall have composed the Council of the preceding year, and shall, in like manner, elect two other persons from amongst the Ordinary Members of the said Society, to supply the places and offices of such two as may have been put out or removed ; and also, that the said Members, or any twelve or more of them, shall and may, at the time and manner aforesaid, elect from the members of the said Society, one President, four Vice-Presidents, a Secretary, and Treasurer of the said Society for the year ensuing ; and also shall and may, in case of the death of any of the members of the Council, or of the President, Vice-Presidents, Secretary, or Treasurer for the time being, within the space of two months next after such death or deaths, in like manner elect other persons, being members of the said Society, to supply the places and offices of such members of the said Council, or of the President, Vice-Presidents, Treasurer, or Secretary, so dying ; and also, shall and may appoint such other persons to be officers of the said Society for the year ensuing, as they may think proper and necessary for the transacting and managing the business thereof. And His Majesty further wills and directs, that, from and after the date hereof, the members of the said Society, or any twelve or more of them, shall and may have power, from time to time, at four quarterly meetings, to be held on the first Thursday of March, June, September, and December, at the usual place of meeting, or at such other place as shall have been in that behalf appointed, by method of ballot, to elect such persons to be Ordinary, Honorary, Corresponding, or Foreign Members thereof, provided that no such Ordinary, Honorary, Corresponding, or Foreign Members shall be declared duly elected, unless two-thirds of the members present at the said meeting shall have voted for the same. And His Majesty further wills and directs, that the said

Council hereby appointed, and the Council of the said Society for the time being, or their quorum before mentioned, all the members whereof having been first duly summoned to attend the meetings thereof, shall and may have power, according to the best of their judgment and discretion, to make and establish such by-laws as they shall deem useful and necessary for the regulation of the said Society, and of the estate, goods, and business thereof, and for fixing and determining the times and places of meeting of the said Society; and also the times and places, and manner, of electing and appointing Ordinary, Honorary, Corresponding, and Foreign Members of the said Society, and all such subordinate officers, attendants, and servants, as shall be deemed necessary or useful for the said Society, and also, for filling up from time to time any vacancies which may happen, from death or otherwise, in any of the offices or appointments established for the execution of the business and concerns of the said Society; and also for regulating and ascertaining the qualifications of persons to be elected Ordinary, Honorary, Corresponding, or Foreign Members of the said Society respectively; and also the sum or sums of money to be paid by them respectively, whether upon admission or otherwise, towards carrying on the business of the said Society, and such by-laws, from time to time, to alter or revoke, and make such new and other by-laws as they shall think more useful or expedient, so that the same be not repugnant to these presents, nor to the laws of His Majesty's realm; provided that no by-laws hereafter to be made, or alteration or repeal of any by-law which hereafter shall have been established by the said Council hereby appointed, or by the Council for the time being, of the said Society, shall be considered to have passed or be binding on the said Society, until such by-laws, or such alteration or repeal of any by-law, shall

have been read or published at the quarterly meeting previous to the meeting at which the same shall be considered, and until the same shall have been confirmed at such meeting, twelve at least of the Ordinary Members of the said Society being then present; and provided that no such by-laws, or alteration or repeal of any by-law, shall be deemed to pass in the affirmative, unless two-thirds of the Ordinary Members present at such meeting shall have voted for the same: And His Majesty doth further will and command, that this charter do pass the Seal appointed by the treaty of Union to be kept and used in Scotland, in place of the Great Seal thereof, without passing any other seal or register; for the doing whereof, this shall be as well to the Director of His Majesty's Chancery for writing the same, as to the Lord Keeper of the Seal for causing the said Seal to be appended thereto, a sufficient warrant. Given at His Majesty's Court at Carlton House the 18th day of August 1824, in the fifth year of His Majesty's reign.

By His Majesty's command,

(Signed)

ROB. PEEL.

CHARTA

SOCIETATEM INTUS MEMORATAM

IN

CORPUS CORPORATUM ET POLITICUM

ERIGENS,

1824.

GEOGIUS QUARTUS, Dei gratia Britanniarum Rex, Fidei Defensor: Omnibus probis hominibus ad quos præsentes literæ nostræ pervenerint, Salutem; Quandoquidem Nos considerantes quod Petitio humilis Nobis oblata fuerit nomine ALEXANDRI, DUCIS de GORDON, Societatis vocatæ in vulgari "*The Caledonian Horticultural Society*" Præsidis; ANDREÆ DUNCAN, Medicinæ Doctoris; JACOBI HOME, Medicinæ Doctoris; JOANNIS ARCHIBALDI MURRAY, Armigeri, Advocati; Domini JOANNIS HAY, Baronetti, de Haystone et Smithfield, Pro-Præsidium; et HENRICI JARDINE, Armigeri, de Harwood; ROBERTI GRAHAM, Medicinæ Doctoris, Regii Professoris Artis Botaniciæ in Collegio Edinburgi; HENRICI COCKBURN, Armigeri, Advocati; Reverendi Doctoris ALEXANDRI BRUNTON, Linguae Orientalis in Collegio Edinburgi Professoris; THOMÆ CRANSTOUN, Armigeri, de Dewar; et GEORGII BELL, Armigeri, in Edinburgo Chirurgi, Consiliariorum; ANDREÆ DICKSON, Armigeri, Thesaurarii; et PATRICII NEILL, Armigeri, ejusdem Societatis Secretarii, pro seip-

sis, et dictæ Societatis cæteris sociis constitutis, enarrans, Quod, in anno Domini millesimo octingentesimo et nono, petitores in Societatem pro amelioratione Horticulturæ in cunctis ejus partibus sese creavissent : Quod eorum conatus magno fuissent bono publico : Quod, summa monetæ haud exigua qua initio cumuli pro isto utili proposito promovendo accumulata, et signo minime vulgari Nostræ Regiæ Benignitatis jamjam recepto per concessionem locationis terræ pro Horto Experimenti causa, in vicinitate urbis primariæ Scotiæ, crediderunt propositum per seipsis cogitatum adhuc ulterius dignum existimatum fore Nostro Regio Patronatu et Tutamine. Idcirco petitores Nobis supplicaverunt sibi concedere Literas Patentes seu Chartam, sese et tales alios quales Socii postea admissi erunt incorporantem in unum corpus politicum et corporatum, eo ut eorum sors capitalis melius administrata esset et secura reddita, sub titulo Societatis in vulgari “ *The Caledonian Horticultural Society.*” Petitores igitur supplicaverunt ut Nobis gratiose placuerit Chartam concedere, petitores, cum iis aliis qui Socii admittentur, incorporantem in corpus corporatum et politicum, per nomen et titulum supra memoratum, cum perpetua duratione et successione, cum potestatibus sigillo communi uti, causas agere et in jus trahi, proprietatem realem et personalem emere et frui, leges privatas pro ejusdem Societatis gubernatione ferre et sancire, cumque cunctis aliis potestatibus et privilegiis necessariis et consuetis. Nos enim certiores facti propositum petitorum laudabile esse, et cupientes istam institutionem promovere, Igitur constituimus, ereximus, et incorporavimus, sicuti Nos ex regia nostra prærogativa et gratia speciali, pro Nobis et regiis nostris successoribus, per hanc Chartam constituimus et incorporamus dictos petitores, et alios qui jamjam dictæ Societatis socii admissi fuerunt, et tales quales Socii ejusdem posthac admis-

si erunt, secundum regulas ejusdem Societatis, in Unum Corpus Corporatum et Politicum, per nomen in vulgari “ *The Caledonian Horticultural Society*,” sub quo nomine perpetuam successionem, et sigillum commune habebunt; et illi, et illorum successores sub eodem nomine habiles, et in lege capaces erunt terra, tenementa, et ulla alia heritagia in Scotia, annum valorem millium librarum Sterlinensium haud excedentia, emendi et possidendi, summam vel summas pecuniæ ulli vel ullis mutuo dandi, et talem securitatem accipiendi ut sibi visum fuerit, et bona et res tenendi, et donativa pro propositis antedictis recipiendi et tenendi: Declarato, Quod omnes chartæ, dispositiones, et securitates hæretabiles, aliave scripta proprietatem hæreditabilem afficientia, per eandem Societatem concedenda, in ejus nomine incorporato capta fuerint, id est, “ *The Caledonian Horticultural Society*,” nominibus vel præsidis, vel ullius munificum seu sociorum constitutorum ejusdem Societatis haud specificatis; et quod ullæ cartæ, dispositiones, aliave scripta per dictam Societatem concedenda per unum e Pro-Præsidibus et per Secretarium pro tempore existentem subscripta fuerint (qui una cum dictæ Societatis munificibus secundum leges privatas et regulas ejusdem nominati erunt), consensu Trimestris Convētūs ejusdem Societatis primo obtento, eo consensu in actis consessus dicti conventus inserto, et quod cuncta scripta ita subscripta tam valida et sufficientia erunt, quam si per totos socios constitutos dictæ Societatis subscripta fuerant; et per nomen et titulum antedictum, causas agere et in jus trahi in omnibus vel ullis curiis nostris judicaturæ, et sigillum commune habere eodemque uti, idemque a tempore in tempus mutare, ut dictæ Societati expediens visum fuerit, et eas leges privatas, regulas et regulationes, cum legibus hujus regni congruentes, quæ prædicto proposito maxime conducere possint, et generaliter omnia alia nego-

tia et res propositum Societatis antedictum promovere valentia, facere et exequi, æque plenarie et ample in omni respectu ut ullum corpus incorporatum legitime facere possit, et ac si hæc negotia et res in hac charta speciatim enumerata fuissent: Et ut hæc consilia melius obtineri possint, et ut successio perpetua eorum idoneorum pro rebus dictæ Societatis administrandis fieri et stabiliri queat, Nos per hanc chartam volumus, ordinamus, et constituimus, Quod, pro meliore administratione et gubernatione dictæ Societatis, et pro meliore directione, regulatione, et executione negotiorum et rerum ejusdem, quod isthinc pro perpetuo fuerint Præses, quatuor Pro-Præsides, duodecim Consilarii, e quibus ulli tres numerus sufficiens vulgo "*a quorum*" erunt, pro propositis postea memoratis, Secretarius, et Thesaurus dictæ Societatis, modo subtus memorato eligendi: Et nos per hanc chartam nominamus et constituimus ALEXANDRUM, DUCEM de GORDON, primum Præsidem, Doctorem ANDREAM DUNCAN seniore, JACOBUM HOME, JOANNEM ARCHIBALDUM MURRAY, et Dominum JOANNEM HAY, primos Pro-Præsides; HENRICUM JARDINE, ROBERTUM GRAHAM, HENRICUM COCKBURN, Reverendum ALEXANDRUM BRUNTON, THOMAM CRANSTOUN, GEORGIUM BELL, ALEXANDRUM HENDERSON, JACOBUM DICKSON, JACOBUM MACDONALD, JOANNEM SHANKLIE, JACOBUM STUART, et THOMAM INGLIS, primos Consiliarios; PATRICIUM NEILL, primum Secretarium; et ANDREAM DICKSON, primum Thesaurarium. Et alterius Nostri mens et voluntas est, ut Socii dictæ Societatis, vel ex his ulli duodecim vel plures, primo die Jovis mensis Decembris anni ab incarnatione Christi millesimi octingentesimi et vigesimi quarti, etiamque primo die Jovis mensis Decembris uniuscujusque anni succedentis conveniant et convenire possint, loco congressus dictæ Societatis tunc ultimo seu alio consueto, et inceperint ullos

duos socios pro consilium anni præcedentis, confecerint, ejicere et remove; et eodem modo, duos alios e sociis ordinariis dictæ Societatis, elegerint, locos et officia eorum duorum qui ejecti et remoti fuerint succenturiare; quoque ut dicti socii vel ulli ex iis duodecim vel plures, unum Præsidem, quatuor Pro-Præsides, Secretarium, et Thesaurarium, dictæ Societatis pro anno sequente, tempore et modo antedicto, eligerint et eligere possint; et etiam in eventu mortis ullius e sociis Concilii, seu Præsidis, Pro-Præsidum, Secretarii, aut Thesaurarii pro tempore existen., intra spatium duorum mensium immediate post has mortem seu mortes, eodem modo alios socios dictæ Societatis existentes elegerint et eligere possint locos et officia istorum sociorum dicti Concilii, vel Præsidis, Pro-Præsidum, Thesaurarii, vel Secretarii, ita morientium succenturiare; et etiam tales alios munifices dictæ Societatis esse pro anno sequente quales proprios et necessarios putabunt pro gerendo et administrando negotio ejusdem, constituerint et constituere possint. Et Nos ulterius volumus et dirigimus, Quod, ab et post datam hujus chartæ, sociis dictæ Societatis, aut ullis ex his duodecim vel pluribus, fas sit et erit a tempore in tempus, apud quatuor tremestres conventus primo die Jovis mensium Martii, Junii, Septembris, et Decembris, tenendos loco congressûs consueto, vel tali alio loco qualis pro eo proposito constitutus fuerit, modo sphæraulæ suffragatoriæ, eligere tales esse Ordinarios, Honorarios, Correspondentes, seu Peregrinos Socios ejusdem, proviso quod nulli tales Ordinarii, Honorarii, Correspondentes, seu Perigrini Socii debite electos esse declarati fuerint, nisi duo tertii Sociorum præsentium in eo conventu pro his suffragia dederint. Et Nos ulterius volumus et dirigimus, Quod Concilio per præsentem constituto, et Concilio dictæ Societatis pro tempore existendi, vel eorum numero sufficienti antea memorato, omnibus ejusdem so-

ciis primo summonitis conventibus ejusdem astare, fas sit et erit, secundum eorum veram sententiam et prudentiam, tales leges privatas facere et stabilire quales idoneas putabunt et necessarias pro moderatione dictæ Societatis, et status bonorum et negotii ejusdem, et pro constituendo et ordinando tempora locosque congressûs dictæ Societatis; quoque tempora, et locos, et methodum eligendi et ordinandi ejusdem Societatis Socios Ordinarios, Honorarios, Correspondentes, et Peregrinos, et cunctos tales officarios inferiores, asseclas, et servos quales necessarios, seu utiles existimabuntur pro dicta Societate, etiamque pro suppeditando a tempore in tempus eas vacantias quæ per mortem seu aliter, in ullis officiis vel institutis pro executione negotiorum et rerum dictæ Societatis ordinatis contigerint; et etiam pro regulando et expiscando facultates eorum qui electuri sunt Socii Ordinarii, Honorarii, Correspondentes, seu Peregrini, dictæ Societatis respective; etiamque summam et summas pecuniæ per eos respective solvendas, vel apud admissionem vel aliter, commodi causa negotii hujus Societatis, et eas leges privatas, a tempore in tempus, mutare et abrogare, et tales novas et alias leges privatas facere quales magis utiles seu commodas putabunt, eo ut eadem huic chartæ, seu legibus nostri regni haud incongruentes sint; Proviso quod nullæ leges privatæ posthac laturæ, vel alteratio vel abrogatio ullius legis privatæ quæ posthac stabilita fuerit, per dictum Concilium per hanc chartam constitutum, vel per Concilium pro tempore existens dictæ Societatis, habitæ fuerint quasi latæ vel obligatoriæ in dictam Societatem donec ista lex privata, vel ista alteratio seu abrogatio ullius legis privatæ, perlecta seu promulgata fuerit, apud conventum trimestrem præcedentem, conventum in quo eodem animo cogitata erit, et donec eadem confirmata fuerit, tali conventu duodecim ad minimum Sociorum Ordinariorum dictæ Societatis tunc

astantibus ; et proviso quod nulla talis lex privata, seu alteratio vel abrogatio ullius legis privatæ, habita fuerit quasi lata affirmative, nisi duo tertii Sociorum Ordinariorum astantium dicto conventui pro eadem suffragia dederint. In cujus rei testimonium, Sigillum Nostrum per Unionis tractatum custodiens, et in Scotia vice et loco Magni Sigilli ejusdem utend. præsentibus appendi mandavimus. Apud Aulam Nostram apud Carlton House, decimo octavo die mensis Augusti anno Domini millesimo octogentesimo et vigesimo quarto, regnique Nostri anno quinto.

Per signaturam manu S. D. N. Regis supra scriptam.

Written to the Seal and registered the 14th day
of October 1824,

THOMAS MILLER, *Sub.*

Sealed at Edinburgh the 14th
day of October 1824,

JAMES S. ROBERTSON, *Dep.*

£80 Scots.

DOCUMENTS

REGARDING

THE EXPERIMENTAL GARDEN.

I. CIRCULAR to the MEMBERS.

SIR,

Edinburgh, Nov. 15. 1824.

I TAKE the liberty, at the desire of the Council and Garden-Committee of THE CALEDONIAN HORTICULTURAL SOCIETY, to transmit to you the following Statement regarding the Experimental Garden, now in progress. I am instructed to ask your support, and that of your friends; and, at the same time, have to request that you will be so good as intimate soon whether it is your pleasure to become a Shareholder or an Annual Subscriber.

I am, Sir, your most obedient servant,

JOHN LINNING.

THE CALEDONIAN HORTICULTURAL SOCIETY, from slender beginnings, has gradually risen in importance,—has greatly extended its connections,—and as, during several

years, its usefulness has been rising into notice, it has obtained more and more of public approbation, and the number of its members has greatly increased. Its efforts have been especially directed to the improvement of Horticulture, by rewarding superior excellence in practical gardeners; by exciting emulation among them; by introducing, through them, new vegetables, or by increasing the cultivation of such as appeared in the market only in small quantity, or had fallen into unmerited neglect. It has also, by means of its Memoirs, recorded and diffused important knowledge, which would otherwise have been lost. The Society has, moreover, since the political state of Europe would admit of it, sent a deputation of its members to the Continent to collect information, and to establish a correspondence with such Institutions and eminent private cultivators abroad, as were likely to add to its usefulness at home. It was at first incorporated under the Seal of the City of Edinburgh; and a Royal Charter has since been procured.

A favourite object of the Society, however, has till now been beyond its reach, the establishment of a Garden in which to deposit its acquisitions in fruit-trees, &c.—to increase them, to determine their value, and from which to distribute them to the public, without any chance of mistake.

The Society is proud to acknowledge the countenance of Government, who have at its request purchased a piece of ground, suited to the purpose, and have granted it to them on a long and renewable lease. It lies immediately to the southward of the New Royal Botanic Garden, so that these two establishments will go hand in hand in promoting a taste for Horticulture, and diffusing a knowledge of it in all its departments. They will form a distinguished orna-

ment to the City of Edinburgh, and, as National Establishments, they will doubtless merit national support.

The funds of the Society, though competent to defray the yearly rent of the ground, are not sufficient for the formation of the Garden, nor for its maintenance when formed. It has therefore been resolved (at the General Meeting held 10th March 1824) to raise additional funds by the following means :

1. By Subscriptions for shares of Twenty Guineas each.
2. By charging every Ordinary Member, not being a Shareholder, with One Guinea yearly towards the funds of the Garden.
3. By charging an Admission-fee of Two Guineas.
4. By voluntary subscriptions.

A large extra expenditure must almost immediately take place. The ground towards the southern boundary must be levelled ;—the Garden must be enclosed with walls, or other fences ;—water must be introduced from the pond in the Botanic Garden, or procured otherwise ;—a small Hot-house, Greenhouse, and several Pit-frames will be found indispensable ;—a Dwelling-house for the superintendant, or Head-gardener, must be built, together with an apartment for the use of the Council and Committee ; and accommodation must be found for several workmen. A permanent fund must also be provided for paying a suitable salary to an able superintendant,—for the wages of workmen, and for defraying many incidental expences which must continually occur.

The Garden will be the deposit of every new variety of Fruit,—of every new Vegetable which can be procured, and is likely to be of value in the horticulture or agricul-

ture of the country,—and of rare plants calculated to become naturalised in Scotland. These acquisitions will be carefully distinguished, so as to prevent the possibility of confusion; and as soon as a due stock is obtained, they will be distributed, under such regulations as may afterwards be passed by the Society.

As the late Governor-General of Bengal the Marquis of HASTINGS, and a number of gentlemen residing in India, have subscribed Twenty Pounds each for shares of the Garden, and have, through Dr WALLICH of Calcutta, remitted this money to Dr YULE of Edinburgh, (forming a fund now yielding interest in the Royal Bank), it has been agreed that these gentlemen shall be considered Shareholders; that, upon their becoming resident, they shall be entitled to all the privileges, and subject to all the regulations, which affect Shareholders; and that, while they continue to reside abroad, they shall have the privilege of appointing, by letter under their hand, any friend to enjoy the use of the garden.

List of Subscribers in India.

The Most Noble the Marquis of Hastings.

The Marchioness of Hastings.

Heirs of J. Adam, Esq.

J. Calder, Esq.

W. Chalmers, Esq. surgeon.

D. Clark, Esq.

Sir R. Colquhoun.

A. Colvin, Esq.

R. Cruttenden, Esq.

L. H. Davidson, Esq.

Lieutenant-Colonel A. Duncan.
 Captain A. Fortune.
 J. J. Gibson, Esq. surgeon.
 G. Govan, Esq.
 Captain C. Graham.
 George Grant, Esq.
 Colonel Hardwicke, Two Shares.
 Major P. Hay.
 J. Mackillop, Esq.
 B. Macleod, M. D. Two Shares.
 Captain D. Macleod.
 Major R. Macpherson.
 J. Macwhirter, Esq.
 P. Maitland, Esq. Two Shares.
 E. Majoribanks, Esq.
 J. Melville, Esq.
 S. Nicolson, Esq.
 John Palmer, Esq.
 A. Robertson, Esq.
 R. P. Robertson, Esq.
 D. Scott, Esq.
 J. Smith, Esq. surgeon.
 W. H. Smoult, Esq.
 P. Steuart, Esq.
 Robert Stewart, Esq.
 J. Williamson, Esq.
 A. Wilson, Esq.
 James Young, Esq.

List of Subscribers for Shares, at Twenty Guineas each.

His Grace the Duke of Gordon.
 The Right Hon. the Earl of Hopetoun, Two Shares.
 The Right Hon. the Earl of Wemyss, Two Shares.
 The Right Hon. the Earl of Lauderdale.
 The Right Hon. the Earl of Dalhousie.

- The Right Hon. the Earl of Dunmore.
 The Right Hon. Lord Melville.
 The Right Hon. Lord Gray.
 The Right Hon. the Lord Justice-Clerk.
 The Hon. Lord Pitmilley.
 Sir Archibald Campbell, Bart. of Succoth.
 Sir Thomas Carmichael, Bart. of Castlecraig.
 Sir George Clerk, of Penicuick, Bart. M. P. Two Shares.
 Sir Robert Dundas, Bart. of Beechwood.
 Sir William Fettes, Bart.
 Sir William Forbes, Bart. of Pitsligo.
 Lieut.-General the Hon. Sir Alexander Hope, G. C. B. Luff-
 ness.
 Sir John Hay, Bart. of Hayston.
 Sir John Hope, Bart. of Pinkie, Two Shares.
 Sir Henry Jardine of Harwood.
 Sir Alexander Keith of Ravelstone.
 Sir George S. Mackenzie, Bart. of Coul.
 Thomas Allan, Esq. of Lauriston Castle.
 David Anderson, Esq.
 John Balfour, Esq. Hailes.
 Heirs of Dr John Barclay, Edinburgh.
 William Bell, Esq. W. S.
 R. B. Blyth, Esq. Edinburgh.
 Andrew Bonar, Esq. of Kimmerghame.
 John Bonar, Esq. Warriston.
 William Bonar, Esq. banker.
 Rev. Dr Alexander Brunton.
 Dr James Buchan, Edinburgh.
 Robert Cadell, Esq.
 John Campbell, Esq. of Carbrook.
 Miss H. Carnegy.
 John Clapperton, Esq. Edinburgh.
 William Clark, Esq. Edinburgh.
 Duncan Cowan, Esq. Canongate.

Rev. Edward Craig, A. M.
James Gibson Craig, Esq. of Riccarton.
General Leslie Cumming.
W. Denniston, Esq. of Oakmount.
Walter Dickson, Esq. of Redbraes.
Andrew Dickson, Esq. of Alton.
James Dickson, Esq.
Mrs William Dundas.
Robert Downie, Esq. of Appin, M. P.
Patrick Dudgeon, Esq. of Eastcraig.
Professor George Dunbar, Rosepark.
Dr Andrew Duncan senior.
Dr Andrew Duncan junior.
Major John Duncan, Bengal Service.
George Dunlop, Esq. W. S.
Daniel Ellis, Esq. Inverleith Row.
Adam Fairholme, Esq. of Chapel.
Dr Robert Graham, Professor of Botany, Edinburgh.
Dr Robert Kaye Greville.
Major Lee Harvey of Castlesemple.
John Harvey, Esq. W. S.
Charles Crossland Hay, Esq.
Alexander Henderson, Esq. of Press.
Alexander Henderson, Esq. of Eildon.
Dr Thomas Charles Hope.
James Howison, Esq. of Crossburn.
James Hunter, Esq. of Thurston.
John Inglis, Esq. of Redhall.
Gilbert Innes, Esq. of Stow.
James Jardine, Esq. Civil Engineer.
James Johnston, Esq. of Alva.
John Ker, Esq. of Kerfield.
John Lauder, Esq.
Charles Lawson, Esq.
John Linning, Esq. Claremont Street.

- Edward Lothian, Esq. Edinburgh.
Mr James Macdonald, Dalkeith Park.
Aitken Megget, Esq.
Robert Menzies, Esq. of Trinity House.
Græme Mercer, Esq. of Mavisbank.
Robert Scott Moncrieffe, Esq.
John Shank More, Esq. advocate.
John Archibald Murray, Esq.
James Nairne, Esq. of Claremont, Two Shares.
Mr Patrick Neill, Canonmills.
Charles Oliphant, Esq. W. S.
Francis Rigby Brodbelt St Penoyer, Esq. of the Moor, Herefordshire.
John Richardson, Esq.
Rev. Dr David Ritchie.
William Robertson, Esq.
George Robertson Scott, Esq.
Claud Russell, Esq. Accountant.
James Scott, Esq. Edinburgh.
William Scott, Esq.
John Smith, Esq. W. S. Edinburgh.
Robert Stevenson, Esq. Edinburgh.
James Stuart, Esq. of Dunearn.
John Swinton, Esq.
David Thomson, Esq. W. S. Edinburgh.
William Trotter, Esq. of Ballendean.
James Tytler, Esq. of Woodhouselee.
Miss M. Viner, Inverleith Row.
Andrew Waddell, Esq. Hermitage Hill, Leith.
David Wardlaw, Esq.
The Rev. Henry Wastell, of Newbrough.
John Wauchope, Esq. of Edmondstone, Two Shares.
Peter Wood, Esq. Leith.
Thomas Guthrie Wright, Esq.
James Wyld, Esq. Leith.

John Young, Esq.
Dr John Yule, York Place.

By a regulation passed 1st December 1825, the price of a Transferable Share to any person *not* a Member of the Society is fixed at Twenty-five pounds.

II. FIRST REPORT of the GARDEN COMMITTEE, 5th March 1825.

ALTHOUGH the CALEDONIAN HORTICULTURAL SOCIETY has been in existence for a period of fifteen years, it has not, till recently, become possessed of funds sufficient to encourage the formation of an Experimental Garden. Its efforts, therefore, have been chiefly employed in suggesting subjects of experimental research to practical gardeners, and in encouraging improved modes of culture, by a suitable distribution of premiums for excellence in the various departments of Horticulture. These efforts have been eminently successful; for, while they have largely contributed to spread abroad a general taste for horticultural pursuits, they have excited among practical men an active spirit of emulation and inquiry, and given increased facilities to the communication of intelligence, which cannot fail to be followed by the happiest results. Scotland has always been pre-eminently distinguished for the knowledge and skill possessed by her practical gardeners; but it is only by providing means for collecting to a focus the scattered rays of intelligence diffused among this class of her people, and blending them with the science and accumulating experience of

the times we live in, that she can expect or hope to preserve this honourable distinction.

The encouragement thus given to private exertion has not been confined to the improvement of our Fruits and Esculent Vegetables. Numerous prizes have been awarded for the introduction of rare and beautiful Flowers,—for the adaptation to our climate of curious and delicate species,—for new and improved methods of cultivation,—and for models of various descriptions of implements connected with Horticulture. As the Society, in conducting experiments more immediately connected with vegetation, hopes to be able to lend its aid occasionally to the patriotic exertions of other bodies, particularly of the Highland Society, among whose members it already reckons many of its warmest supporters.

The practical benefits which have already resulted from the Society's labours are undeniable. It is well known, that the vegetables now brought to the Edinburgh market are not only in greater abundance, but of superior quality to those formerly exhibited: and the same may be observed of the common as well as of the finer fruits. The conviction thus afforded of the success of the Society's endeavours has so far improved its means, as to encourage it to carry into effect the plan which it has long contemplated, of establishing an Experimental Garden, for the improvement of Horticulture in all its branches.

The funds, however, in the hands of the Treasurer, will not suffice to organise the establishment in the manner most to be desired. The views, therefore, of the Society, as contained in the present report, are, in some instances, to be considered rather as prospective, than as about to be immediately realized, unless its resources be considerably augmented. It is, consequently, a matter of the highest

importance to the Society, that all who are anxious for the prosperity of the Experimental Garden, or desire to be connected with it, should come forward at this period. It might then be placed at once upon a basis that would ensure the most beneficial results to the art which it is destined to foster and improve.

In July 1824, a piece of ground was purchased for the Crown by the Honourable the Barons of Exchequer, and granted by them to the Society, for an Experimental Garden, upon a long and renewable lease.

This ground, containing eight Scotch or ten English acres, is situate on the north side of Edinburgh, and forms a part of the lands of Inverleith. It lies immediately to the southward of the Royal Botanic Garden, from which it is separated by the wall lately erected by the Society. It has an open aspect to the south and south-west; is well sheltered to the north and north-west, by the Botanic Garden, and the woods of Inverleith; and to the east and north-east, by the plantations around Warriston House. The soil on the east and south is in part a light loam, of excellent quality, resting on sand; the remainder, and greater portion to the west and north, is deep, rich, and strong. Water for all purposes is derived in great abundance from the same source as that which supplies the Botanic Garden.

The operations for forming the Garden commenced in August 1824, by levelling the ground to a great extent on the south, in compliance with a stipulation in the lease. This measure, though attended with much labour and expence, will ultimately be of considerable benefit to the Garden, by forming a fine sloping bank along the extent of its southern boundary; and from the judicious manner in which it has been executed, the whole of the vast quantity of soil

and subsoil, which it was found necessary to remove, has been disposed of within the walls, and distributed so as greatly to improve the soil in some parts, and in others advantageously to vary the surface line. In the course of these preliminary proceedings, a bed of excellent gravel was laid open, from which a quantity has been obtained sufficient to cover the greater part of the walks. These important operations of levelling requiring uncommon accuracy and attention, have been executed much to the satisfaction of the Committee, under the direction of Mr Robert Niven, who had previously been employed under Mr Macnab, in works of a similar nature, during the formation of the Botanic Garden.

The Committee agreed, after the various objects which the Society had in view had been fully discussed, that two of their own number should prepare a Plan for laying out the ground. This task chiefly devolved on Mr Macnab, and has been performed in a manner highly to the satisfaction of the Committee. The plan subsequently received the sanction of the Council. It has been engraved, and is appended to this report; and we have no doubt that it will obtain the general approbation of the Society. It has been drawn up with the most careful reference to the general features of the ground in regard to its aspects, and to the varying conditions and qualities of the soil: Those compartments allotted to standard fruit-trees have been placed on the western side, where the soil is deepest, and best calculated to receive them; and exterior to these, the *Arboretum* has been disposed in such a manner as to unite the purposes of shelter, ornament, and utility.

In forming the various Walks, attention has been paid to combine beauty of design with the readiest communication throughout all parts of the ground. The principal walk, which encircles the whole garden, may be particu-

larized here, as constituting, on one side, a splendid terrace-walk, of near 700 feet in length, commanding one of the finest views of Edinburgh on the south, and of the Botanic Garden on the north, bordered on each side by an extensive collection of roses and evergreens.

The principal entrance to the garden will be on the south side ; but from the state of the adjoining ground, it will not be in the Society's power to complete it for some time. A second entrance, which is already open, is approached from Trinity road, and is on the east side. Immediately within this entrance will be placed the Gardener's house and the Committee-room ; with an ornamental Flower Garden on the left. It is intended that the suite of Hot-houses, &c. shall be placed a little farther to the west, in the same line, and looking to the south ; and behind them the Framing department. Opposite to, and in front of, the Hot-houses, will be a garden dedicated to Florists' Flowers ; separated by a skreen of shrubs and evergreens from the *Culinarium* or Kitchen Garden, which forms a large square nearly in the centre of the ground.

Following the central walk beyond the Hot-houses, we find, on the left hand, an inclosed compartment for experiments, and, on the right hand, a collection of stocks and seedling trees. We then enter immediately the large compartments allotted for standard Fruit-trees, which are intersected from north to south by a raised belt, of a semicircular form, to receive the inferior and more hardy species. These compartments, with a part of the Arboretum lying beyond them, occupy the whole western division of the Garden.

Returning to the entrance, and proceeding along the north, or right-hand walk, we find the north-eastern angle appropriated to an enclosed space for select experiments ; and at a small distance in advance, on the opposite side,

the department for American Shrubs, Aquatic and Rock plants. The fine Wall to the right of this walk separates the Horticultural from the Botanic Garden: it is 14 feet high, with a south aspect, and is variously constructed of stone and brick, with an express view to experiments.

Recurring again to the entrance, and following the south or left hand walk, we observe, behind a small screen, a Slip running along the eastern wall, having a western aspect, and destined as a nursery-wall for fruit-trees, with borders for raising seedling and herbaceous plants. On the opposite side of the walk are three compartments, for Annuals, Seedling Trees and Shrubs, and *Gramineæ*; these are separated by a walk from a large triangular space dedicated to an ample collection of the most ornamental or otherwise interesting Perennial Plants.

The fine sloping bank on the southern entrance to the garden has been exclusively appropriated to the cultivation of Strawberries, and the smaller fruits.

Although the objects that will chiefly claim attention in the Horticultural Garden are pretty well known, it may not be out of place shortly to enumerate them. It is proposed to cultivate the different varieties of fruits and esculent vegetables, paying strict attention to the qualities and habits of each, and instituting comparative experiments on the modes of treatment and of culture to which they are usually subjected; so as to obtain a knowledge of those which appear to be the best varieties, and, as far as may be, of the most appropriate methods of culture. Of the vegetable productions which belong not to the classes of fruits and esculents, a selection will be made according to their relative degrees of utility or beauty; so as to exhibit specimens of the finer varieties, and of the modes of culture best adapted to the plants which adorn the shrubbery and

flower-garden. In every department also, new plants, and new and improved varieties of those already known, will be eagerly sought for; and the Society flatters itself, that, by the extensive correspondence it has established with eminent Horticulturists both at home and abroad, it will be able to give early information of what is doing elsewhere, and submit to actual investigation the merits of any plants, or any new modes of culture, that may seem likely to advance this interesting department of knowledge.

Buds, grafts, and seeds of the vegetables cultivated in the Garden, will be freely distributed to Proprietors and Subscribers, according to regulations hereafter to be made. But care will, at all times, be taken to avoid interference with what may be regarded as the proper business of the Public Nurseries: with the enlightened proprietors of these the most friendly intercourse will be kept up, which, it is not doubted, will prove equally beneficial to both.

The whole Garden, except two small portions set apart for curious and select experiments, will be open to Proprietors, Subscribers and their friends, under regulations to be made by the Council and Garden Committee; and will, it is believed, form a most attractive source of instruction and recreation. Every plant will have its name attached to it; and the time of flowering and ripening its seed, together with its various properties and qualities, will be carefully recorded.

Such being the objects at which the Society aims in the establishment of this Garden, the Committee venture to recommend it to the enlightened liberality of their countrymen, as highly deserving encouragement and support. They beg to state, that a large outlay of money has already been made in enclosing and forming the ground; and that to build the hot-houses and other offices essential to the es-

tablishment, a yet larger sum will be required. In all their operations, the Committee, acting under the advice and sanction of the Council, have proceeded with the utmost regard to economy ; but it has also been their wish to execute what has been undertaken in the best and most satisfactory manner. In a few weeks, they trust, the enclosing walls will be completed, the principal walks formed, and the several compartments allotted for the different uses specified in the plan, distinctly marked out. They, therefore, respectfully invite those who take an interest in the establishment, to visit the scene of their operations, and judge for themselves of the progress already made, and of what yet remains to be accomplished. In circumstances the most favourable, and with the most abundant resources, the formation of a garden is not the work of a day. Its productions, however much fostered by art, must owe their perfection to the silent, and not unfrequently the slow, operations of nature. But these operations may often be greatly accelerated by a judicious employment of the means which pecuniary resources supply ; and, indeed, without such aid, many important objects, which the Society anxiously contemplates, cannot be accomplished. In behalf, therefore, of an establishment, destined to improve an art held always in the highest estimation in this part of the kingdom,—an establishment which will furnish a recreation at once so healthful and instructive, and contribute largely, it is hoped, to increase the amount of our domestic comforts ; the Committee earnestly solicit the public patronage and support, and feel assured, that such solicitation will not be made in vain.

Terms of Subscription.

To this Report the Committee append the terms of Subscription, as they relate either to the Society and Garden

jointly, or to the Garden alone, with a statement of the privileges attaching to each class of Subscribers. By these terms it is proposed to raise the necessary funds in the following manner :

1. By Subscriptions for Shares of Twenty Guineas each : every Share to become the absolute property of the holder, and be transferable in the same manner as any other personal property, provided there be no good objection to the person in whose favour the transfer is proposed to be made, —and upon payment of Two Guineas by the person to whom the transfer is made, excepting legal representatives, who shall only be obliged to make up such legal title to the share as the Council shall approve of.—Shareholders to have personal access to the garden, and also their friends accompanying them, at all times when the garden is open ; likewise the privilege of giving Written Orders to Visitors, under such regulations as the Council may from time to time direct.

2. By charging every Ordinary Member, not being a Shareholder, with One Guinea yearly towards the funds of the Garden : this contribution being, of course, voluntary with former members, but compulsory upon all those admitted after the General Meeting in June 1824.—It will confer all the privileges belonging to a Shareholder, except the power of admitting visitors by written orders.

3. By charging an admission-fee of Two Guineas upon every gentleman elected an Ordinary Member of the Horticultural Society subsequently to June 1824.

4. By soliciting Noblemen and Gentlemen who reside at a distance, and may be expected to patronise the undertaking, to become Shareholders on the terms proposed above ; or, at their option, to subscribe such other sum as they may incline towards its support : it being understood that such Subscribers shall have the privilege of personal

access to the Garden when they happen to visit Edinburgh, and a claim to a portion of such grafts, plants, or seeds, as may, from time to time, be distributed, in proportion to the amount of their subscriptions.

It is requested that communications be addressed to Mr A. DICKSON, Treasurer of the Society, Waterloo Place; Mr NEILL, Secretary, Canonmills; or Mr J. LINNING, Garden-Treasurer, Claremont Street.

ILLUSTRATION OF THE ENGRAVED PLAN.

AAAAAA, *Orchards for Standard Apple, Pear, Plum, and Cherry Trees.*—They occupy a space containing nearly 2 Scottish, or $2\frac{1}{2}$ English acres, and are calculated to contain about 550 fruit-trees, at 12 feet apart every way. As the apple-trees, however, will mostly be trained *en buisson*, and many of the pear-trees *en quenouille*, 8 or 10 feet apart will generally be found sufficient: so that the number of trees may be greatly increased. It is here intended to form a collection of all the best varieties of hardy fruits, to be procured in this country, and from the Continents of Europe and America: which will be brought with the utmost diligence into a bearing state, in order that the kinds may be proved, and the nomenclature fixed. We shall thus ascertain with precision those kinds best suited to the climate of Scotland; grafts or buds of which will be subsequently distributed to the Members.

B, *Central enclosed Experimental Garden.*—A portion of ground enclosed by a holly hedge, with a door to be kept under lock and key for select experiments.

CCCC, *The Culinarium or Kitchen Garden*, containing nearly an acre of ground.—Besides paying every attention to the more

PARK of INVERLEITH

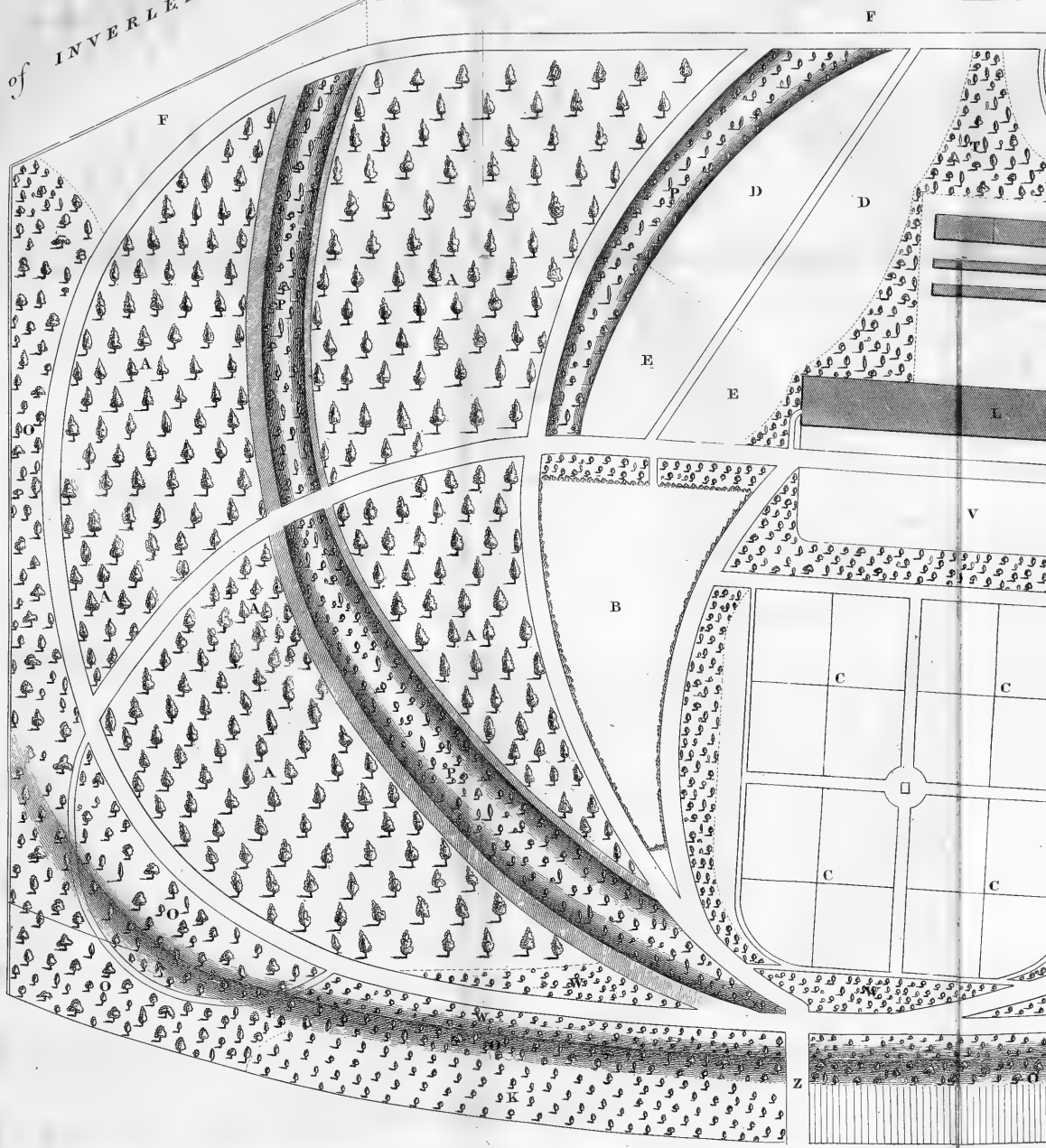

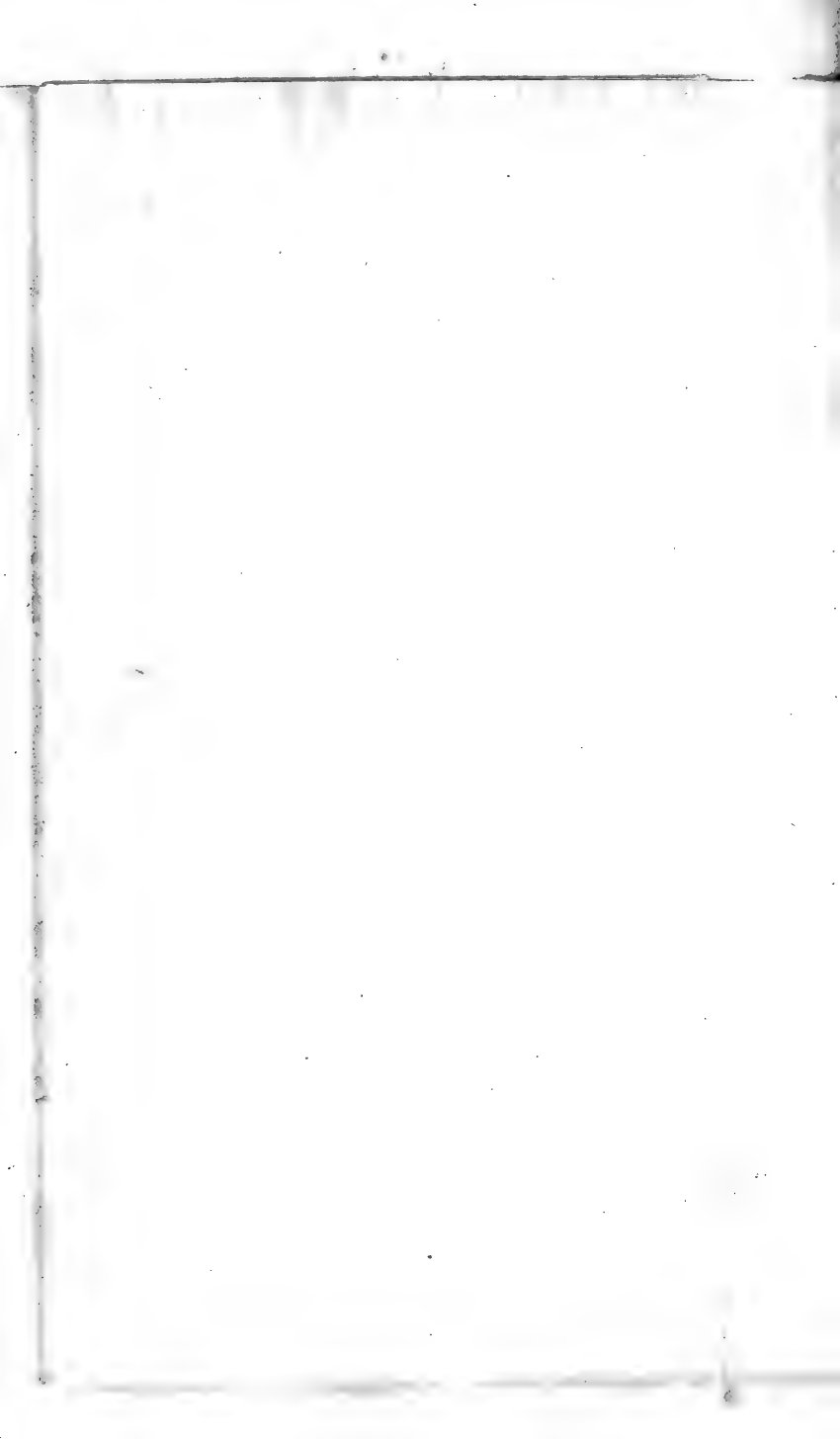

ordinary kinds worthy of cultivation, all the new or little known varieties of culinary vegetables will be fairly tried, in beds of considerable extent ; and the relative advantages of various modes of culture determined. A copious supply of water is conveyed to a cistern in the centre of this compartment.

DD, Compartments for an ample assortment of *Stocks* of different kinds for grafting or budding : such as Paradise and Doucin Stocks for Apples ; Quince Stocks for Pears ; Plum and Almond Stocks for Peaches, Nectarines, Apricots, and Plums ; and Guin and Mahaleb Stocks for Cherries.

EEE, Nurseries for rearing Seedlings, Offsets, Cuttings, and Layers of the rarer trees and shrubs.

FF, Principal Wall, with a south aspect, for the finer kinds of fruit trees : as Peaches, Nectarines, Apricots, Cherries, Almonds, the best French and Flemish Pears, Figs, Quinces, and hardy Grape-Vines, with an exemplification of the different modes of training. This wall is in general 14 feet high : 402 feet are built of coursed freestone, 75 of coursed whinstone, and 210 are faced with brick. Three kinds of coping have also been adopted for different portions of the wall. The border in the front is 18 feet broad, and is formed in the most efficient manner, with a compost which has been long in preparation. Part of it has been laid with a bottom impenetrable to the roots of trees. On this border, also, it is intended to raise the choicest annual esculent vegetables ; and in this warm situation, some of the rarer varieties may be expected to ripen their seed, and ultimately become more hardy.

GG, *Walled Experimental Garden*.—An enclosed space in the north-east angle of the ground, enjoying the advantage of walls, with south and west aspects, to which new or rare fruit-trees and delicate shrubs may be trained. Part of this enclosure is to be devoted to the naturalization of tender exotics. This, and the compartment B, will be kept locked, and under the immediate charge of the Society's

Gardener, in whose presence they may be visited by the Members.

- HH, *The East Slip*:—having a wall 8 feet in height, with a west aspect, for new varieties of dwarf fruit-trees, and a nursery border for raising new plants from seed.
- I, *Eastern Division of South Slip*:—a fine border sloping to the south, well adapted for the cultivation of Strawberries; and where the different species and varieties, at present in great confusion in Scotland, may be correctly ascertained and distinguished.
- K, *Western Division of South Slip*:—intended for a collection of the small fruits, such as Gooseberries, Currants, and Raspberries. Those varieties which require a deeper and richer soil, and a more sheltered situation, will be commodiously placed between the rows of trees in the lower division of the Orchards.
- L, The site for the erection of a Hot-house for tropical fruits, and a few ornamental plants; a Greenhouse, chiefly for the Citrus tribe, Chinese plants, &c. and Forcing Houses for late Peaches, Nectarines, Grape-vines, &c. The plan of these houses is not yet prepared, and must be modified for the present in proportion to the extent of the Funds. The space allotted to them is 200 feet in length, by 25 in breadth, including back-sheds. In the front will be a border 12 feet in width. The aspect is a little to the eastward of south, so that the houses will face the sun about a quarter before 11 o'clock.
- MM, *The Framing Department*,—150 feet in length, by 100 in width, for Ananas and Melon Pits, Cucumber and Gourd frames, with room also for different Earths, Composts, and Manures.
- N, Enclosure, sheltered by an evergreen hedge, for Greenhouse Shrubs, and other plants kept out of doors during the summer months.
- OOOOOO, *General Arboretum*; for large trees and tall shrubs which produce dry capsules, and fruits little used as food; so disposed around the Garden as at once to afford

shelter, produce ornament, and serve the purpose of a scientific collection.

- PPP, *Raised Belts*.—The larger ones dividing the orchards are intended for middle-sized trees and shrubs producing small fruits, such as Guins, Mulberries, Medlars, Azeroles, Mountain-Ash, Crabs, Barberries, &c. The smaller belt, next to the stock department, is appropriated to a collection of Chesnuts, Walnuts, Filberts, Hazel and Cob nuts. These raised belts, formed at a trifling expence during the levelling of the ground, constitute a part of the Arboretum, and will eventually afford much shelter.
- Q, Compartments for a collection of the most ornamental sorts of Perennial Herbaceous Plants.
- R, Another compartment, destined for the cultivation of the most desirable Annuals, and for naturalizing the more tender exotic species.
- S, A portion of ground set apart for receiving plants used in Agriculture ; as Grasses, Clovers, &c. ; where experiments may be tried at the suggestion of those interested in promoting the agriculture of the country.
- TT, *American-Shrub Department*, with prepared borders. Here also will be the Pond for aquatics, surrounded by a mass of Rock-work for alpine plants, &c.
- U, A space for plants with striped and variegated leaves.
- VV, Ornamental Flower-borders for Carnations, Pinks, Ranunculuses, Anemones, Stocks, and other plants producing double flowers, as well as for Tulips, Hyacinths, Polyanthus-Narcissus, &c.
- WWW, *The Rosary*, forming a border on each side of the south terrace-walk through nearly its whole extent ; calculated to contain a collection of all the known species and well marked varieties.
- X, Entrance from Trinity-road, with a cart-way into the frame-ground.
- Y, Site of the Gardener's house and Committee-room, with apartments for arranging and keeping seeds, &c.

Z, South entrance to the Garden, (which cannot be formed till a road be carried along that part of the Inverleith estate).

All the walks are to be laid with gravel found in the grounds, excepting those having a dark shade in the plan, and passing through the arboretum, which are to be formed of grass.

III. SECOND REPORT by the GARDEN COMMITTEE, 15th June 1826.

A PERIOD of more than a year has elapsed since the Garden Committee, acting under the direction of the Council, made their First Report. It was then stated, that the operations of levelling, forming, and inclosing the ground, were in active progress; and the Committee have now the satisfaction of reporting that they have been nearly completed. The several portions of land allotted for the Arboretum, the Orchards, the Culinarium or Kitchen-Garden, the Flower-Garden, the Melon-Ground, and other smaller compartments, have, in different instances, been inclosed by raised belts of Trees and Shrubs, or by fences of Holly or Hornbeam, which, in a short time, will contribute greatly to the purposes both of shelter and beauty.

On every side the ground is now shut in either by walls or paling; and, keeping in mind the experimental purposes of the Institution, the chief wall on the north side has been built of different materials, and with different forms of coping, with the view of ascertaining which mode of construction may prove most advantageous for Fruit-Trees of various descriptions. Water of good quality has been obtained, in great abundance, from the Botanic Garden; and it is in contemplation to form the Pond for Aquatics, with

its appropriate Rock-work for Alpine plants, as soon as the more urgent operations of planting are completed. Since the former report, an excellent Dwelling-house, in the cottage style, from designs furnished by Mr Playfair, architect, has been built for the Superintendant or Head-gardener ; and estimates have been required for erecting a small Greenhouse and Hothouse, for the reception of such Exotic Fruits and Flowers as may be presented to the Society. These glazed houses will be constructed with the view of forming hereafter a suitable portion of the more extended range described in the original plan.

The Committee beg leave shortly to repeat, that the objects which will chiefly claim attention in the Experimental Garden, are the cultivation of the different varieties of Fruits and Esculent Vegetables, paying strict attention to the qualities and habits of each, and instituting comparative experiments on the modes of culture to which they are usually subjected, so as to obtain a knowledge of the best varieties, and the most successful methods of culture. Specimens of the finer varieties of plants which adorn the Shrubbery and Flower-garden will also be selected ; and, in every department of Horticulture, new plants, and new or improved varieties of those already known, will be sought for. By means of an extensive correspondence with eminent Horticulturists, both at home and abroad, it is hoped the Society will be able to collect, from different countries, many of their various products of Vegetables, Fruit-trees, Shrubs, and ornamental plants. Of these they will endeavour to naturalise the finer and more useful kinds to our soil and climate ; and they will communicate to the public, from time to time, the results of their experiments, so as to render their labours generally useful.

Cuttings, and, as often as possible, rooted plants, of the various Fruit-trees cultivated in the Garden, will be freely

distributed to Shareholders and Members, according to regulations hereafter to be made. Strawberry plants, and new or rare varieties of Culinary Vegetables, will in like manner be distributed. With the exception of two small portions, set apart for curious and select experiments, the whole garden will be open to the different classes of Members and their friends, under regulations to be made by the Council and Garden Committee.

For conducting the operations and superintending the general business of the Garden, the Committee have the satisfaction to report, that the Council have engaged, as Head-gardener, Mr James Barnet, a young man of whose knowledge and zeal they entertain a high opinion. Mr Barnet is the son of a Scottish gardener, and received the first lessons in his art under his father, and subsequently under Mr Macnab, in the Royal Botanic Garden at Edinburgh. Since then he has been employed in the Royal Gardens at Kew, and in the Garden of the London Horticultural Society, where he held the office of Under-gardener, and had the management of the Fruit department. He was recommended to the Council by Mr Sabine, the Secretary to the London Society; and is already well known to British horticulturists by his account of the different varieties of Strawberries cultivated in the garden of the London Horticultural Society, and published in their Transactions.

In reporting the progress made in the establishment of the garden, the Committee seize the opportunity of gratefully acknowledging the aid they have received from *Donations*, of various kinds, made to the Society by many of its members, and by different amateurs of horticulture in various parts of the kingdom. The earliest contributor was Dr Duncan senior, the Father of the Society, who, in February 1825, sent a number of young fruit-trees from

his garden at St Leonard's. Their warmest acknowledgments are due to Dr Graham, the learned and liberal Professor of Botany in this University, through whom they received, in April 1825, from the Royal Botanic Garden, Inverleith, the greater part of the ornamental shrubs and trees, both evergreens and deciduous, with which the belts are planted. To Dr Hope, they are also deeply indebted for a large collection of shrubs and herbaceous plants, from the old Botanic Garden at Leith Walk. From Mr Macdonald, Dalkeith Park, they likewise received, in April 1825, on the part of the Duke of Buccleuch, a liberal store of fine holly plants, and other evergreens, with young trees of nearly forty kinds of hardy fruits cultivated in His Grace's gardens. During the past spring of 1826, they have been greatly indebted to the London Horticultural Society for various contributions of Fruit-trees, of uncommon kinds, with a collection of the different ascertained kinds of Strawberries, exceeding 50 sorts; and they acknowledge, with gratitude, the liberal spirit which, on all occasions, Mr Sabine, the indefatigable Secretary of that magnificent institution, has manifested to serve their infant establishment, and to keep up with them a correspondence, which, they trust, may hereafter prove mutually beneficial.

Among individuals for whose donations it has been their pleasing duty to offer thanks, the following may likewise be mentioned: Messrs William and James Wilson, nurserymen, New York; Professor Dunbar, Rose Park; George Bell, Esq.; the Right Hon. Sir John Sinclair, Bart.; J. A. Murray, Esq.; Lady Eleanor Butler and Miss Ponsonby, Plas Newydd; the Rev. John Smith, Whithorn; the Chevalier Masplet, French Consul; and Mr William Anderson, Chelsea Botanic Garden. The principal nurserymen at Edinburgh have also contributed, and have liberally promised further contributions when

young trees of the different genera, species, and varieties, come to be required for the Arboretum.

In connection with this branch of their report, the Committee beg to express their warmest thanks to the Nobility and Gentry, who, not only as Members of the Society have aided their efforts, but encouraged their Gardeners to communicate such new methods of cultivation as experience may have suggested, and transmit such superior specimens of produce as their art may have supplied. The Memoirs of the Society bear ample testimony to the many valuable hints and improvements derived from this class of its correspondents; and which are at once creditable to the skill of the Gardener, and to the liberal spirit of the Proprietor that fosters and encourages it. To this respectable class of its members, the Society looks for continued assistance; and invites such intercourse and communication between them and the Superintendant of the Experimental Garden, as cannot fail to prove useful to both parties. In no way can the objects of the Society be more efficiently accomplished, than in becoming, as it were, a centre towards which all the practical improvements made in its vicinity shall tend, and from which they may again be disseminated to fructify a wider circle.

It will gratify the Society to learn, that not only have assistance and promise of support been received from kindred establishments and lovers of horticulture in these kingdoms; but that a correspondence has been opened, and assistance zealously proffered, by similar establishments in various quarters of the globe. With the national establishment called the "Jardin des Plantes" at Paris, now under the direction of the celebrated M. Bosc,—with a Horticultural Society at New York, and with another similar establishment in New Holland, a correspondence has been already commenced: while many individuals, distin-

guished for their love of natural science in general, and of Horticulture in particular, and who reside permanently in North and South America, and in our various Colonies in the East and West Indies, have liberally offered to aid our inquiries, and assist our endeavours to procure such valuable and rare fruits and plants as their respective countries may produce ; so that there is reason to hope the Society will obtain early intelligence of whatever discoveries, in relation to horticulture, are made in almost every part of the world.

But, though much has been already done, much yet remains to be accomplished. It is proposed to commence, as soon as funds can be obtained, the erection of a part of the Hot-houses, with suitable sheds, &c. ; but the funds of the Society fall short of the sum required to finish the entire range, with its Conservatory, Committee-room, and Dwelling-apartments for one or more labourers, as delineated in the Plan. To form the Pond also ; to construct the Framing department for pine-apple and melon pits, cucumber and gourd frames ; to purchase the necessary earths, composts, and manures ; to procure plants to stock various departments of the Garden ; and furnish many necessary utensils, &c. &c. will still demand a large expenditure, in addition to the annual charge for rent, salary, wages, and various incidental expences.

It is the wish of the Society to defray the various charges for the necessary buildings, and for whatever may be deemed requisite for the permanent establishment of the Garden, out of the sum obtained by contributions for Shares, and by donations of smaller amount ; and to devote the Annual Subscriptions to the ordinary expences of the current year.

The expence already incurred has necessarily been great ; and farther disbursements to a considerable amount will be

found indispensable towards completing the formation of the Garden. To support the Garden in proper style will require numerous yearly subscriptions. It is therefore earnestly requested, that gentlemen, who wish the establishment to prosper, will lose no time in coming forward either as Shareholders or as Annual Subscribers.

Having thus exhibited, for the information of the Society, an outline of what has been already done, or will speedily be accomplished, the Committee regret to state, that, unless the funds be augmented, so as to complete the Hot-houses to the full extent of the plan, the Society will be compelled to relinquish many liberal offers of plants from various parts of the globe, which their correspondents abroad have made them. They therefore earnestly solicit all their Fellow-Members to exert their influence with their connections and friends to procure additional subscriptions. Scotland has been always distinguished for the knowledge and skill possessed by her Practical Gardeners; but she can preserve this distinction only by availing herself to the utmost of the increasing intelligence in this department of art, so rapidly spreading through every civilized country. In France and Italy, public institutions for the improvement of Horticulture have long been established, and men of the greatest eminence in the natural sciences have been appointed to cultivate and teach its various branches. In our own country, the Horticultural Society of London is flourishing beyond all precedent. By the enlightened liberality of the Nobility and Gentry of that portion of the empire, an annual revenue of several thousand pounds is collected and dispensed for the improvement and extension of horticulture. Under its auspices, skilful persons are sent out to various countries, to collect and bring home whatever promises to enrich our horticultural stores. Even

the counties of England nearest to us (Northumberland and Durham) have lately established, and liberally patronized, an Horticultural Society, on an extensive scale; and shall it be said that the Nobility, Gentry, and Public of Scotland are less zealous for the improvement of an art, so well suited to the genius of her people, and in which they have hitherto taken so decided a lead? Nothing surely can be expected so much to excite a spirit for improvement, and stimulate the efforts of the practical gardener, as the knowledge that his skill and success are not confined within the walls that circumscribe his operations, but are made known to his fellow-labourers in the art, and even spread abroad, among the lovers of horticulture, through the most distant countries. At the present period, too, when most of the arts of life, hitherto conducted by handicraft and routine, are about to receive a new impulse, from the light let in upon them by the general establishment of Mechanics' Institutions, it is most desirable that similar advantages should accrue to Horticulture, by a more general combination of principle with practice, of science with art, and of rational experiment with pre-established fact. Certainly, to its perfect cultivation, there is no art that demands a wider range of natural and experimental knowledge than the practice of Horticulture, nor any that holds forth greater prospects of improvement from the successful application of scientific principles. To the resident Public of Edinburgh, it may safely be asserted, that few institutions can better deserve their patronage, or promise higher gratification. In a short time, this Garden, connected, as it is, in plan and situation, with the Botanic Garden, will become one of the chief ornaments of the city; while the facility of access to it, the commanding beauty of its site, and the ever-varying succession of new objects it will continually offer to view,

must afford that pure pleasure to which none are insensible, and from which many will derive the truest satisfaction and delight.

MEMOIRS.

MEMOIRS.

I.

Account of a new Mode of Grafting Camellias.

By GEORGE DUNBAR, Esq. Rose Park.

(Read 10th March 1825.)

OF the exotic plants that have been introduced into this country during the last fifty years, none surpass in beauty and variety the genera *Camellia* and *Erica*. The former, it is well known, is a native of China and Japan, and the latter of the Cape of Southern Africa. From twenty to thirty different varieties of the *Camellia* have, within these few years, been brought from China ; and it is probable that many more exist in that country, which have not yet become known to Europeans.

The common method of multiplying the different kinds, consists in inarching or grafting a double

upon a single, by bringing the two plants together, and joining two branches of each kind, having previously cut out an equal portion of the bark and wood of both, so as to make them unite exactly. But as this process is sometimes inconvenient, and scarcely admits of more than one or two double shoots being grafted on a single at the same time, I have for several years practised a different method, by which almost any number of doubles may be grafted upon a large single stock, without the smallest inconvenience, and with little chance of failure.

There are only two seasons of the year when Camellias can be grafted with any chance of success, namely, the spring and autumn, because at these two periods they begin to make new growths. The month of April may be considered as the best season for grafting them, as the young shoots of both the double and single are then produced more vigorous than in the months of September and October, and, of course, are more likely to unite. They may, however, be brought into this state by artificial means; and as it is of importance for every one who cultivates this most beautiful genus, to know the proper method of treatment, by which he may expect them to thrive best, and produce the greatest number of flowers, I shall state that which I have found most successful, before I explain my mode of grafting.

As the *Camellia* is a native of a much warmer climate than ours, it therefore requires a greater degree of heat than is even produced in a greenhouse, during the early summer months, to cause it to shoot out vigorously, and thoroughly ripen its flower-buds for the following flowering-season. In no situation do *Camellias* thrive better than in a vinery, under the shade of the vines, and participating of all the heat which is usually given to a house of that description. They should be watered over head with a syringe twice or thrice a-week, to remove any dust that may have settled upon the leaves, and to refresh them. During this period, also, plenty of water should be given them, as the heat very soon exhales it from the pots. About the beginning of October, if the buds are well formed, they should be taken from the vinery to the greenhouse, and have as much air admitted to them as possible. In this state, their buds will gradually expand, and, when full blown, will remain much longer, and appear much finer, than if the plants had been kept in a vinery or a stove. Great care must be taken to allow no water to reach the petals, as it completely deforms their beauty, and causes them to fall off prematurely. When the flowers have all disappeared, which in ordinary sized plants will generally happen about the month of March or the beginning of April, the plants ought then to be again removed to the vinery; and the process of engrafting may be begun when the

young shoots in both the single and double begin to swell, which they seldom fail to do, after being about a week or a fortnight subjected to the heat of the vinery.

It may be premised, that the branch of the single to be grafted upon should be nearly of the same size as that of the double, because the adhesion first takes place in the bark of both, and if they do not correspond, they will not readily unite. Suppose a single consists of six branches, and a different variety of doubles is to be grafted upon each, the first thing to be attended to is, to select a clean, healthy shoot of last year's growth, from each double, about six or eight inches in length, and cut it off by a joint. The incision in the single should be as near the separation of the branches from the stem as possible, and should be about an inch and a half in length. The bark on the side cut should be entirely removed, with a small portion of the wood; and the same must be done with the double, so that the incision in both may exactly correspond. It is also advisable to tongue them, as I have generally observed that the adhesion first takes place where the tongues unite. The incision in the double shoots should be made about an inch or an inch and a half above the under part, as nearly the whole of that portion of the wood is to be immersed in a small phial constantly filled with water, to keep it in a growing state. This phial must be tied firm to the branch of the single, to prevent it from falling off. When





the branch of the double is applied to the single, care must be taken that the bark of both correspond, and that the cuts are of equal length. They must then be bound as firm and close as possible with a string of matting, and some moss (*hypnum*) wrapped round, which should be kept constantly moist. The portion of the double below the junction must then be immersed in the phial, and if this is kept constantly full of water, so as to promote the growth of the double, the adhesion will take place in a month or six weeks. It is, however, advisable to allow the phial to remain some time longer, and not to remove the bandage till the double has made some growth.

The sketches in the plate annexed exhibit the process in its different stages.



Explanation of Plate II.

- a, a, a, a,* Length of the incision in the single and double.
- b, b,* Tongue of both.
- c, c,* Incision of the double shoots above the under part.
- d, d,* Phials filled with water.
- e, e,* Strands of matting.

II.

Remarks on the French Methods of Cultivating the Peach-tree.

By MR JOHN SMITH, formerly of Hopetoun House Garden.

(Laid before the Society 9th June 1825.)

THE influence of climate enters as an important element into every comparison of the productions of different countries. Hardly any two are precisely similar in this respect, and, consequently, there arise many variations, which confer advantages on one country, to which it may be impossible to attain in any other. Yet it is found that climate exerts more than its intrinsic influence. If, for instance, it is so unpropitious as to make the growth of any article an uncertain speculation, there is neither competition in the market, nor emulation in the garden; and every improvement which might thence arise, is effectually prevented. This is peculiarly true with regard to the Peach. In France, it is considered the surest of all fruit, and has therefore become an object of regular demand in the market. Whole districts and villages have devoted themselves to its culture, in which the desire of gain has directed the gardener to natural principles of ma-

nagement,—has rooted out old methods and old prejudices,—and generated a wish to excel, which, acting in a thousand nameless and extemporary operations, seldom fails to arrive at its object. In Britain, on the other hand, especially in this northern division of the island, peaches must be regarded as a precarious crop. We are generally content to get as many as we can, without anxiously enquiring whether we have more than our neighbours. In consequence of this, our general improvement in cultivation has been comparatively small; and in this respect our peach trees form a striking contrast to strawberries, gooseberries, and certain culinary vegetables, in which we surpass the French in a higher degree than they do us in the peach, and for the same reason, namely, a more regular and extensive demand for supply.

But although climate thus tends directly and indirectly to obstruct our own advances in improvement, it does not seem necessarily to preclude us from availing ourselves of such as have been made by others. Our first care, indeed, ought to be the amelioration of our climate by hot-walls, and other expedients, exclusive of forcing houses. Much has not hitherto been effected in this way, and it is not to be doubted, that in the gardens of Montreuil we might gather many hints to aid us. But this must be the work of time. Meanwhile, we may have recourse to the French methods of pruning, as a thing more within our reach, and select and adopt what

seems most interesting, or worthy of imitation. If we are not deceived by the parade which in most of their horticultural works is made with physiological principles, their system of management is chiefly characterized by the attention which is paid to the theory of vegetation, and the peculiar growth of the tree. This, indeed, has been carried to an over degree of refinement by some physiologists, and, as it appears, without much injury; for, when the philosopher becomes too subtle, he is invariably lost sight of by the simple operator. We would earnestly recommend such as are interested in this subject to consult the works of Mozard and Du Petit Thouars, the *Bon Jardinier*, and especially the *Pomone Française* of Count Lelieur, as we shall find it impossible, within our limits, to convey an idea of their many principles and observations with the requisite minuteness and precision.

The French practice differs from ours in the following particulars:

I. In some of those subordinate operations which necessarily find a place in every system of management.

II. In the form of the tree, and the re-production of bearing branches.

I. The artificial extension of a tree upon a wall deprives it of its natural liberty, which it makes incessant efforts to regain, and thus gives rise to such operations as nailing, tying, pruning, disbudding,

&c. which being indispensable, are found wherever wall-training is practised. But of the modifications of which these admit, the French have had recourse to many which are either entirely neglected, or but partially used in this country.

The growth of large, spongy fore-right shoots, is generally very troublesome to the cultivator. These, after absorbing a considerable portion of the sap, and deranging its distribution, are usually removed in the summer pruning, or sometimes not till the winter. The French are careful to prevent their appearance, by picking out the buds, both before and behind the shoots, previous to their breaking. This operation is called *ebourgeonnement à sec*, and, as we shall afterwards see, is extensively applied in some of the forms.

The strength of young shoots, which, from their relative position, ought to be equal, varies frequently with the size of the buds from which they sprung. It is of importance to correct this, especially in the early stages of training; and it is effected by pinching off the extreme points of the more vigorous shoots. Before these can again push out, they must have become to a certain degree ligneous, and have formed perfect wood-buds at their points. While this is taking place, the unmutilated weaker shoot acquires the necessary strength.

In France, there are certain peculiarities in the summer pruning (*ebourgeonnement*), or, as it is

sometimes called, disbudding, which merit attention.

It is known that such branches as are left loose, and capable of motion, grow more vigorously than those which are attached to the wall. From this has been derived a rule, which may appear sufficiently obvious, viz. to nail or tie in the stronger shoots first, and to leave the others to acquire vigour by agitation and the free access of air. This important rule is applicable to all sorts of fruit trees, and implies that the summer pruning is not to be considered as finished in one operation,—an opinion which seems to obtain too generally amongst gardeners. In stating this practice as an improvement of the French, it is fair to remark, that the fact upon which it is founded has been observed by Mr Knight, and is the principle upon which he treats plants under glass; but, as far as we are aware, he has not applied it to the training of wall-trees.

An upright shoot is observed to grow more freely than one which is forcibly deflected from the perpendicular. In order, therefore, to reduce two shoots to an equality, we may elevate the weaker and depress the stronger one. It is to be remarked, that this rule is applicable to *shoots* only when the trees are young, but that it always exerts an effective influence on the limbs or members of the tree.

From the tendency of the sap to flow in a perpendicular direction, it must be evident that the shoots on the upper side of an inclined branch will

always be more luxuriant than those on the lower. To obviate this inconvenience, the strongest shoots, as far as circumstances will admit, are preserved below, at the period of disbudding, while the weakest only are retained above. By this means, the shoots on each side of an inclined branch, in some forms of training at least, can be kept in the most perfect equality.

It is presumed that these operations will appear trivial refinements to those who put little value on the regularity of a tree, and the equal distribution of its branches, or who entertain the fallacious notion that these qualities can be at any time obtained by a single application of the pruning-knife. But every experienced gardener must know, that a peach tree without regularity can neither be productive nor long-lived, and that its branches are by no means reduced to an equal strength when cut back to equal lengths. The operations which I have just detailed, are in fact of the utmost moment, since they enable us to maintain the equilibrium of the sap,—to husband the resources of the tree, and obviate the necessity of repeated amputation, of which the peach-tree is extremely impatient. They are, besides, of so easy application, and so little subject to perversion, that I cannot doubt that the adoption of them would contribute much to our success in the culture of this and other kinds of fruit.

II. The training of fruit trees on walls, though evidently an artificial operation, is not the work of arbitrary caprice. There are some limits which cannot be passed, without nullifying the purpose of all training, viz. the production of fruit. These arise from the peculiar growth of the tree,—its duration, the mode in which the fruit is produced,—and other circumstances connected with the theory of vegetation. Thus, in the peach, the tendency to divaricate, and the growth of the fruit, not on spurs, but on the young wood, has introduced the semi-stellar or fan-training, at least in all cases in which its culture has been skilfully practised. Other limits, such as the equilibrium of the sap, and the greatest possible facility of reproducing fruit-branches, have restricted the French to certain varieties of what has been called the open fan-training. All these modifications proceed upon a principle which is much insisted on, viz. “the suppression of the direct channel of the sap.” Most fruit-trees, when left to themselves, form an upright stem or trunk, which conveys the nutritive juices from the roots to the upper extremities. This tendency shews itself even on walls, and hence apple and pear trees have been generally trained with central trunks. It is also observable in the peach-tree, although in a less degree; and we consequently find Forsyth, and a few of his followers, training it with the upright stem, from which all the subordinate branches diverge at right angles. This the French condemn, alleging

that the sap is wholly carried up to the superior members. They also proscribe the fan-training with a central limb (our common form), on the score of its being destructive of equilibrium *. They therefore divide the tree into two equal portions, which they spread out diagonally, leaving the centre completely open. It does not seem very evident that this arrangement is indispensable to maintain the equilibrium; but it certainly facilitates it greatly, and, besides, it enables the cultivator to accommodate the tree to low walls, and, by preventing confusion and irregularity, contributes much to ease and freedom in the operations of pruning and training.

1. The form of training which is most generally adopted in France, is that of Montreuil. It appears to have been invented about the beginning of last century; but it was scarcely known before 1755, when it was brought into notice by the Abbé Roger Schabol, the most eminent French horticulturist of his time. According to the principle already mentioned, the tree is divided into two equal parts, in the form of the letter V. In order to effect this, two and sometimes four principal branches (*mère-branches*) are established, which constitute, as it were, the skeleton of the tree. The following

* In the *Bon Jardinier*, some trees are described with central branches, which is a departure from the theory. They do not appear to be numerous in the French gardens.

sketch from the *Bon Jardinier* of a tree three years trained, will give an idea of the arrangement :

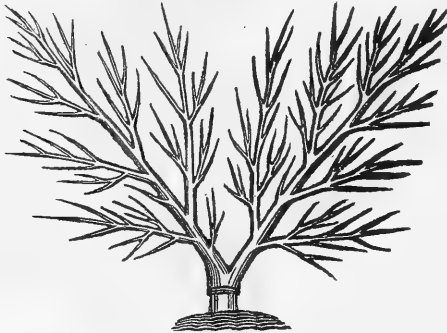

Fig. 1

In the case of the two *mère-branches*, they are attached to the wall at an angle of 45° ; but when there are four, the central angle is somewhat less. Although recommended in most French works, it is not advisable to fix the branches at first in so low a position as they are ultimately to occupy, since the branches in the centre will invariably get the start of the others, as has been experienced in certain attempts at imitation in this country. The other branches are all situated on these principal limbs, and diverge from them at angles varying with the age and vigour of the tree. Great care is taken to preserve them in due subordination to the leaders. The bearing shoots are treated pretty much as they are in this country. In the execution of the training, the operations above described are more or less

applied according to the intelligence of the cultivator. For a more detailed account, the reader may be referred to the Horticultural Tour, p. 429. where, along with many other valuable remarks, will be found an interesting account of the Peach Gardens of Montreuil.

2. The next form which we shall notice, and which is entitled at least to the praise of ingenuity, is that termed by Count Lelieur the form *à la Dumoutier*, from the name of its inventor. It is stated to be an improvement of the V of Montreuil, and to be distinguished from it and all others, in being less divaricated,—in having its principal members more strongly marked,—and by the entire renovation of the bearing-shoots every year, which being cut down almost to their insertion, give a pinnated appearance to the branches. The following account is gathered from the *Pomone Française*, a work of considerable merit, although, like every other French treatise on horticulture which I have seen, it patronises one mode of operation exclusively, and passes over all others in silence. It is worthy of notice, that some of Count Lelieur's figures are given in the *Jardin Fruitier* of Noisette, vol. i. and are said in the letter-press (which seems to have been pruned down to a series of insipid generalities in passing through the hands of a *redacteur*) to represent the common form of Montreuil.

As is commonly practised, the stock (of almond or plum) is planted where the tree is destined to

grow, and in the following summer two buds, nearly opposite to each other, are inserted. These produce two shoots, the future *mère-branches*, which are trained (Fig. 2.) nearly in a vertical position, and ought to be as equal in strength as possible. At the first pruning, they are cut down to about 15 or 18 inches in length, and the buds both before and behind are removed by *ebourgeonnement à sec*. The result of the second year's growth is the prolongation of the mother-branches (*a*, Fig. 3.),



Fig. 2

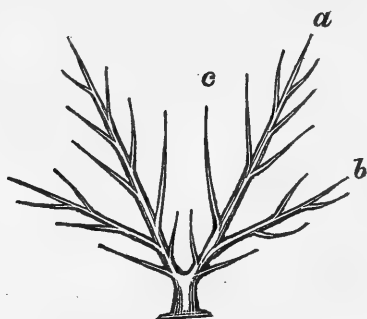

Fig. 3

and the addition of another branch (*b*) on the outside of each. The following summer affords a third pair (*c*); and at the end of that season the tree has the appearance indicated by Fig. 3. During the fourth or fifth year, each of the branches *a*, *b*, *c*, divides into two. Of these three, viz. *a*, *b*, *c*, (Fig. 4.) proceed in their original direction, while the others *d*, *e*, *h*, diverge, and become subordinate members. The next two seasons produce the remainder *f*, *g*,

k, l, m, which complete the developement of the tree. Every successive year brings the mother-shoots *a* lower, till they are inclined at about an angle of 25°. The annexed figure

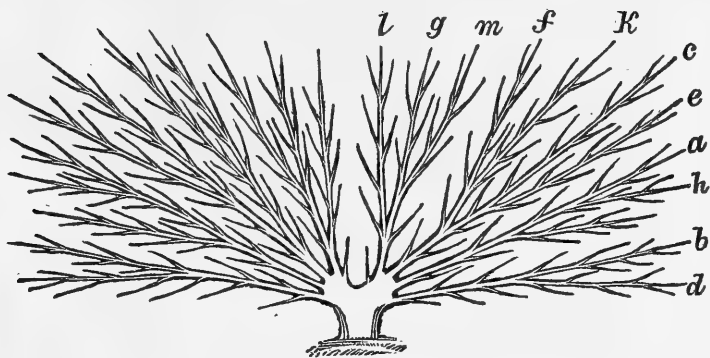

Fig - 4

is from a tree which in nine years covered a space of wall 42 feet long and 8 feet high.

The points of the leading shoots are shortened every year to such an extent as circumstances require. So much is symmetry studied, that Count Lelieur instructs us to ensure the equality of both sides by admeasurement ; and he assures us that this is always possible, if the tree has been properly managed. In order to produce this, however, the most scrupulous attention is given to regularity, all the means of equalizing the branches are called into exercise, and even the lateral twigs, and those por-

tions of the shoots which are to be cut off in the pruning, are carefully arranged and manipulated.

The pruning for fruit commences in the third year, and is performed with much exactness. As already noticed, the whole of the bearing wood, with perhaps a few exceptions, is renewed every year. The lateral shoots which appear during summer at the extremity of the leading branches, are cut back to a single eye, together with all other shoots which have no fruit-buds, and at the same time are feeble. When a shoot promises blossom, it is generally at some distance from the point of insertion into the old wood, and the intermediate space is covered by wood-buds. All the latter, therefore, which are between the old wood *a* and the blossom *c* (Fig. 5.),

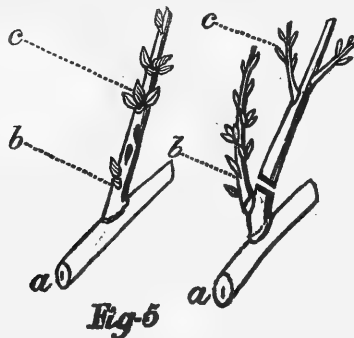

except the lowest *b*, are carefully removed by *e-bourgeonnement*. This never fails to produce a shoot, the growth of which is favoured by destroying the useless spray above the blossoms, and pinch-

ing off the points of those which are necessary to perfect the fruit. This is termed the *bourgeon de remplacement*. Barren shoots, when too vigorous to be cut down to their lowest eye, are treated exactly in the same manner. At the winter pruning, the branches which have borne fruit are cut down to the insertion of the replacing shoots, which, in their turn, are *ebourgeonnée*, bear fruit, and cut out like their predecessors. In cases where the blossom has failed in setting, or the fruit in stoning, when the shoot is too weak to ripen the fruit which are upon it, or when the crop is very early, this operation may be performed at any period in the course of the summer. It is then called *Raprochement à vert*. Occasionally, a very promising shoot which has already fruited, is suffered to remain. The replacing shoot is cut back to its lowest eye; or if it is vigorous, and there is room, it is made in the usual way to produce a substitute. In either case, a new replacing shoot is obtained, to which the whole is invariably shortened at the end of the second year. The branch thus treated is styled the *branche de reserve*.

It is to be remarked, that the replacing shoot, and the branch of reserve, form a part of the Montreuil system of pruning for fruit, but less attention seems to be bestowed upon them, and the *raprochement* or cutting back is not so rigorously performed; for we find the fruit-branches passing into subordinate members, while in the form we have just

now described, they remain single and undivided. It is obvious that these operations might be applied to any system of training, even by those who would hesitate to adopt one of the French forms in all its details. It is but justice to observe, that a near approach to these operations has been made by Harrison, in his excellent directions in this department of the culture of peaches.

3. There is yet another variety of the Montreuil form, denominated *à la Sieulle*, with which the English reader is already acquainted through the medium of the Horticultural Tour, and which is noticed here, that it may not be confounded with the one last described. The tree is likewise formed upon two mother branches, which, being selected in the first summer, are permanently fixed at the inclination of from 25° to 30° , leaving, consequently, a very large angle in the centre. These leading branches are never shortened. Late in the first autumn all the buds are removed except three, one of which is terminal, the other two at equal distances on opposite sides of the shoot, the one on the outside being nearest the stem. The growth of the second summer lengthens the shoots in their original direction, and produces one from each of the reserved buds. At the beginning of the second winter, the leading shoots are again laid in at full length; the side shoots are shortened about one-third; and, as before, only three buds are allowed

to remain. After the lapse of another year, the tree has assumed the following appearance, Fig. 6.

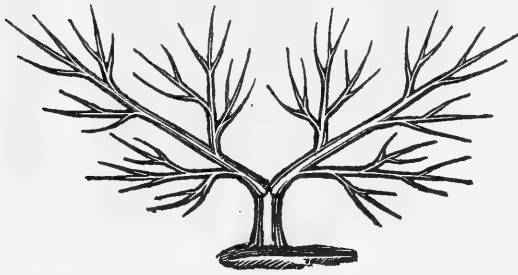

Fig-6



Fig-7

Fig. 7. represents a side shoot, after being shortened and disbudded. The same process is continually repeated. The mother-branches grow on in a straight line, and those on the sides pass into subordinate members.

This method proceeds upon the position, that fruit-trees are more weakened than strengthened by pruning. Sieulle was led to this conclusion by observing the effects of shears in topiary work. There is, however, but little analogy between clipping and pruning; and in old trees, where the two leading shoots bear no proportion to the others which are annually shortened, the principle is virtually given up. It must be admitted, however, that the continual *ebourgeonnement* economises the force of the tree, by limiting the number of shoots, and preventing the appearance of those which grow only

to be cut off. A considerable diminution of labour is also gained in the busy period of summer.

Under this mode of pruning, the quantity of blossom is necessarily small, since only three double flower-buds at most are ever left on one shoot. This, however, obviates the necessity of thinning the crop, and is said to increase the size, and consequently the flavour of the fruit. In the invariable climate of France, it should seem, that the gardener may calculate on the setting of any given flower.

This method of training has been warmly patronised by M. Du Petit-Thouars, who considers it as an exemplification and proof of some of his peculiar notions on vegetable functions. Other French horticulturists object to it, on the ground that the low elevation of the mother-branches encourages the growth of the superior members, to the detriment of those below; that the extreme exactness of dis-budding and pruning is apt to generate an over luxuriant habit; or, at least, that it does not admit of modification, when such a circumstance—possible in every kind of training—accidentally occurs. The first allegation is said to be disproved by the trees of M. Sieulle himself; but we are not informed how the others are got rid of.

After these details, it may be presumed that the reader will be disposed to agree with Thouin (*Annales du Museum*), that the open fan-training admits no of half knowledge in theory, and still less

in practice. It cannot be supposed, therefore, that in France it is generally practised such as we have described, or rather such as it appears in French works on gardening. But it is well to have an elevated *beau ideal*. We confessedly possess nothing of the same sort which will bear a comparison with it. In conclusion, as we have been considering the good points in the French practice, it may not be less beneficial to attend a little to the defects in our own. Our accusations, it is hoped, will not wear the air of disparagement, and will be understood to apply merely so far as the limited observation of the writer extends.

The adaptation of *stocks* to soils has not been sufficiently studied in this country. In France, the Peach is budded on almonds in dry situations; while such as are destined for heavy loams are inserted on plums. It may also be noticed, that the French seldom venture peach trees on such clayey soils as we not unfrequently do.

Instead of budding the tree on the spot on which it is to grow, or transplanting it when, in technical phrase, it is a *maiden*, that is one year old, we, in our impatience, have recourse to trees which have been trained in the nurseries. Such plants, by a rigorous application of the knife, are made to produce an abundance of showy wood, and at the same time are so circumscribed, that they do not cover half as much wall as the French trees of the same age. The vegetable energy, thus confined within a

narrow space, is ready to burst forth, in whatever irregular manner chance may determine.

The principal members, which form the skeleton of the tree, are seldom sufficiently distinguished from the other branches. Taking their origin chiefly from the centre of the tree, they become too crowded, and they are further allowed to separate into an indefinite number of subdivisions. This defective arrangement, in general, and especially when combined with the foregoing circumstances, fails not to overthrow the equilibrium of the sap.

Again, there is a want of distinction between the subordinate members and the bearing shoots. The latter too frequently pass into the former, and then, in the confusion which follows, amputation either of larger or smaller branches becomes necessary. This pernicious operation is quite indispensable in those methods of pruning recommended by Mr Knight and others, in which reversing and bending of the bearing-shoots are prominent features.

In consequence of these irregularities, the reproduction of fruit-branches is greatly impeded. Shoots preserved merely for fruit, or perhaps for no purpose at all, are allowed to grow on till they have attained the length of several feet; and as they frequently run parallel, within a few inches of each other, they are entirely naked, except perhaps at the points, where there may be two or three twigs, often too feeble to perfect the fruit which they produce. In such cases, the blossoms can neither be vigorous nor abundant.

In stating these defects of the English system of Peach culture, we do not mean to derogate from the skill and intelligence of the enlightened part of our horticulturists. It is necessary, however, to state the disease in the worst form, that the remedy may be more readily applied. It is not intended to recommend as such the whole of any one of the French methods above described; but I am persuaded that some benefit may be reaped from their consideration, in the way of practice, and perhaps still more in acquiring clearer notions of what peach training ought to be. The opinion of Mr Knight is indeed adverse to this. He thinks that our methods are already too much Frenchified, and that in respect of excessive severity of pruning. In answer to this, it might, with deference, be shewn, that the French modes of pruning, *in France itself*, are far from being severe; and perhaps it would not be difficult to resolve his objections into those made a little above, grounded, as we have seen, on faults of which, unfortunately, we have all the merit. But it is not becoming to reply to such a horticulturist as Mr Knight in any other way than by facts. Instead, therefore, of advising the general adoption of the French system, I would recommend it to the notice of our experimenters, whether public or private, to whom I am confident it will ultimately approve itself, whenever it meets with a careful and candid examination.

III.

*On the Cultivation of certain Ornamental Plants
in Flower-pots filled with Hypnum-mosses.*

In a Letter from Mr JOHN STREET Flower-Gardener
at Biel, to the Secretary.

(Read June 9. 1825.)

SIR,

IN compliance with your request, of date Mar. 11. 1825, I now communicate some of the advantages which I apprehend arise from cultivating exotic plants in Mosses or *Hypnums*. I find that several species of exotic plants grow quite well in common flower-pots filled with such mosses. They may be used with much advantage; especially for species which require large pots and much moisture; for such pots, when filled with earth, so saturated with water, are rendered heavy to lift or carry about, and the pots are liable to break. I find that the *Canna indica*, *Canna patens*, *Datura arborea*, *Agapanthus umbellatus*, *Hydrangea hortensis*, *Eucomis punctata*, *Eucomis striata*, *Calla æthiopica*, *Eranthemum pulchellum*, *Abroma augusta*, *Hermania incisa*, with several others, all most readily send forth roots in these mosses, and thrive well. Cuttings of the *Hydrangea* readily strike root in the

moss, and soon form flowering plants. If manure is thought needful, it may be easily added, either as a fluid, or otherwise.

Of *Hibiscus rosa sinensis* flore pleno, I planted some cuttings in pots filled with moss, and I was agreeably surprised to see how quickly these cuttings made strong roots. At the same time, I planted some cuttings of it in pots filled with suitable earth; and these had not made any roots after the lapse of a similar period, although otherwise treated alike. The plants in moss flowered in the autumn, and continued in bloom till the end of October.

In January 1824, I placed some cuttings of *Buddlea globosa* in a pot filled with moss, and kept it in a shady place, under cover, without artificial heat: they soon made roots, and they produced flowers in the month of May 1825, in the same pots, though they had met with very hardy treatment.

The yellow Crocus grows, and blows well in pots filled with moss; and some other bulbs would perhaps also succeed.

As a general remark, I may observe, that all ornamental plants which will grow in mosses in pots, are, when so grown, much better adapted for placing in sitting-rooms, or any apartments of the dwelling-house, as being much more cleanly. Earth is very apt to wash out of the pots in giving water, and to cause dirt in the stands; with moss this cannot occur.

An additional advantage gained in cultivating

plants in moss, was suggested at the meeting of the Society, viz. That plants might be sent to any distance without pots, safer than in earth and pots; the roots penetrating the moss, and forming balls, which would retain moisture for a great length of time.

As to the kind of mosses to be used, I prefer those mosses which grow in plantations, because we find many bits of rotten spray and decayed foliage mingled with them; and the addition of such substances is very desirable. The species which I chiefly use are *Hypnum proliferum*, *prælongum*, *parietinum*, *cuspidatum*, *squarrosus*, and others which grow in damp woods.—Pull up the moss with its roots; or, if the place of growth admit, cut it up with an inch of the surface vegetable mould adhering to it: or the moss wetted, may be rolled among vegetable earth, which will adhere to it. Some plants grow well in the pure moss; but many more will succeed in moss mixed more or less with such earth. Among these I may particularize *Disandra prostrata*, *Cineraria lanata*, *Cineraria populifolia*, and its varieties; also some Pelargoniums. I might likewise mention *Aster argophyllus* and *Gazania rigens* as thriving well in moss and earth mixed.

This leads me to advert to your offer of a medal “for a Flower-pot of Improved Construction, in regard to form, quality of materials, effectual draining,” &c. I think the use of mosses will greatly ob-

viate the difficulty arising from the imperfect form, &c. of flower-pots.

For plants of very large growth, I use any kind of tubs, boxes, barrels, or even packing-cases which may have conveyed things from one place to another, and are then perhaps usually destroyed; but in such packing-cases I find large plants grow well in moss. In fact, it is nothing to the plant whether the vessel be round or square, very compact and close, or porous and open; and when moss is used, draining needs little to be thought of.

Mr Salisbury, in his Treatise on Wall Fruit-trees, recommends protecting the blossoms of fruit with the long hypnum mosses in the cold changeable weather in spring: in this I concur, especially where they may be got near at hand. When they have served that purpose, they will answer well to raise plants in pots. They are also very useful to be laid about the roots of plants from which it may be required to keep out the drought of summer or the frost of winter.

Nurserymen and amateur cultivators of exotic plants, who can get hypnum mosses near at hand, I presume may save some expence by using them, instead of driving carts several miles with *fancy earths*, which, when procured, may, after all, be improved with hypnum moss. Such moss, I think, possesses a power to some extent of regulating temperature, more than most kinds of earth; that is, it resists extreme heat and extreme cold, and is not

apt to lose all moisture suddenly, while it discharges superfluity of moisture. It does not act like some rich earths, giving out all its virtues at first, but becomes gradually richer in decay, when a fresh supply may be added, in the same space of pot-room.

Last year, I planted some early potatoes in hypnum moss. The moss was laid in the trench, and the seed-tubers placed on it; these were then covered with another coat of moss, and, lastly, covered with earth, and the surface digged level as usual. The crop was fully as good, and as soon ready for use, as the same kind of tubers, planted at the same time and place in dung-litter. Although on a cold clay bottom, on a rising ground, much exposed, I gathered some sizable potatoes on the 10th of June. This leads me to imagine that hypnum mosses may be successfully applied in growing potatoes in heavy soils, or where the soil is already considered rich enough.

I gathered a barrow-full of hypnum moss in the middle of December, and laid it in a corner under the north side of a wall: in a few days afterwards, it became rather warm; so that I think it may be serviceable in forming hot-beds. The decomposition will be very gradual, and the heat moderate and long continued. This may deserve investigation and trial.

BIEL,)
10th April 1825.)

(Medal voted to Mr STREET.—See *supra*, p. 68.)

IV.

*On the Economical Arrangement of Fruit-trees
in a small Garden.*

In a Letter from Mr JOHN DICK, Gardener, Ballindean,
to the Secretary.

(*Read 10th December 1819.*)

SIR,

I AM now to lay before the Horticultural Society a method, for obtaining a great deal of fruit from a small piece of ground. I have myself put it in practice, and it promises to give satisfaction in the highest degree. It will answer for apples, pears, cherries, and several kinds of plums.

The method consists chiefly in having the trees planted and trained as espaliers, and in planting them in rows, in one plot of ground by themselves.

I shall here give a representation of a small plot of ground planted with apple-trees in the manner recommended.

NORTH.

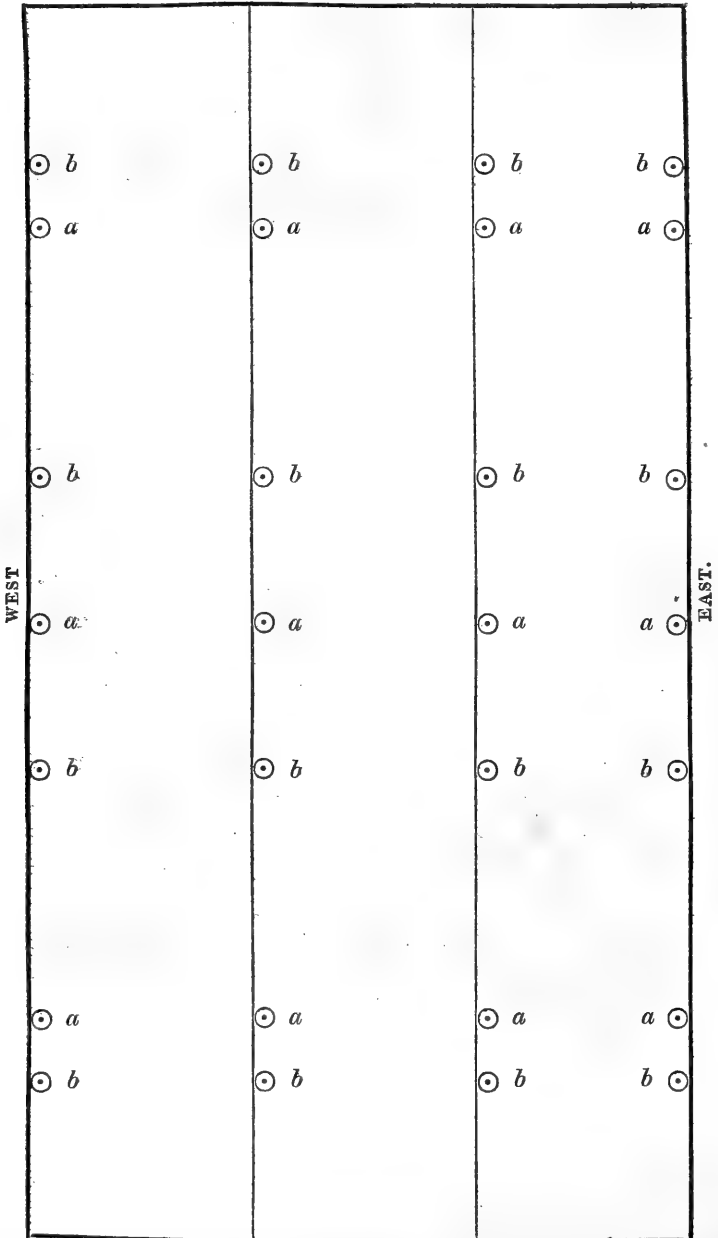

SOUTH.

Explanation of the Plan.

At the letters *a, a, a*, are placed trees upon crab stocks, at 20 feet distant, for the permanent or standing trees. These are planted upon the west side of the rails.

At the letters *b, b, b*, are placed trees upon paradise stocks, at 15 feet distant, for temporary trees, or for giving fruit until the others meet together. These are planted upon the east side of the rails.

The whole of the ground here represented is about 13 falls.



The distance between the rows of espalier trees is 8 feet; and the height of the espalier-rails is 5 feet. These are the proportions which will prevent any of the trees being shaded, until the season arrives that all the fruit will be gathered.

The distance between the permanent trees, upon crab stocks, in the rows, is 20 feet; and there are three of them to each row. There are four temporary trees, upon the east side of the rails, upon paradise stocks: they are at 15 feet distance in the rows, and intended to give a supply of fruit until the permanent trees meet together.

The above calculation is for apple or cherry

trees : however, a few feet more or less can be allowed, as there may be ground to spare.

The rows should be made to run the length way from south to north ; and, by so doing, each side of the tree will, through the season, have the sun equally divided, which is a very great object gained. If the garden or ground where the trees are planted have a wall or shelter upon the north side, which is often the case, the north end of the espalier-rails should be as near the wall as it can be placed. I wish it to be understood, that there is a border at the foot of the wall, and a walk also, and it is the south side of the walk that I would have the north end of the espaliers to be near. In planting the trees, the finest kinds should be planted upon the north end of the rows, as the sun has more influence the nearer the wall. I could have given the strength of the sun at different distances from the wall ; but this is easily found, by placing three or more thermometers at different distances from the wall in a clear sunny day.

Trees planted in this disposition shelter each other, and the ground between them can be easily manured along with slight crops of kitchen vegetables, and rendered very useful ; whereas espaliers and standard trees upon borders are very often neglected, the borders being crowded with herbaceous plants or rose-bushes, which rob the roots of the trees.

It will be observed what a number of trees can in

this way be planted upon a very small piece of ground, where they can be kept in good order, and the ground about them still made very profitable. There may be 28 trees planted upon about 13 falls of ground, which could not be done in any other method, to be of any use: besides, such fruit-tree quarters are very ornamental in any garden or inclosure.

The trees can be supported with stakes, which will answer very well; but if any choose to have a proper rail made, it will be still more ornamental. If the trees were planted above broad thin flag-stones, it would be of great use, their roots being thus kept from getting too deep into the subsoil. I have said nothing about the preparing of the ground, but leave that to every one to perform in the best manner he has in his power. I would recommend maiden trees to be planted, as they are most likely to give satisfaction.

Standard fruit-trees, although kept low, are much shaken by the wind, and their fruit is not so good as that of the same kind produced on espaliers. I may add, that the fruit produced on these espaliers, is of higher flavour than that procured from wall-trees. Besides, several fine sorts of apples and pears will produce fruit upon espaliers, that will yield very little upon standards.

P. S.—As some persons might be afraid of the sun's shadowing the espalier rows too much, I add a diagram, shewing the sun's height upon 23d September, in this latitude of 56° .

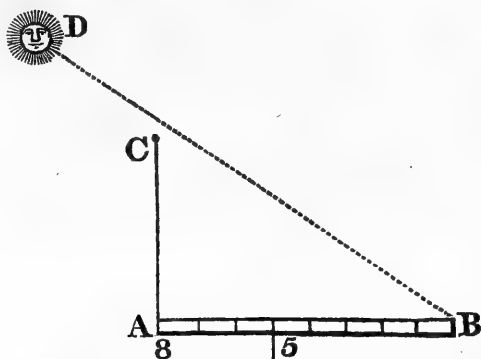

At 12 o'clock noon, the sun is about 36° of altitude. AB is the distance between the rows, 8 feet, the scale being 5 feet to an inch: AC is the height of rails; BD is the sun's altitude, 36° above the horizon AB, which thus gives sufficient sun until the fruit be gathered.

BALLENDAN, }
30th Nov. 1819. }



Additional Communication, contained in a Letter from Mr Dick to the Secretary, dated 16th November 1826.

(Read 7th December 1826.)

IN compliance with your request, I now send you a sketch of the economical plantation of apple trees at Ballindean, upon a more extensive scale, and in an improved and more distinct style than the draught which I sent you to be laid before the Horticultural Society in November 1819.

The draught now sent †, I have laid down mathematically to a scale of five feet to an inch. The permanent trees are marked in their proper places thus * , and the temporary trees thus +. You requested a list of the varieties of apple trees thus planted at Ballindean; but in place of such list, the name is placed at the site of each tree. The letters ABCD mark out the extent of the piece of ground, and its length from east to west, and from south to north. As in the former plan, the trees upon crab stocks are to remain permanently, and

† See Printed Plan.

the trees upon paradise stocks are intended for removal, as the others come to occupy their place.

The distance between each row is 8 feet. The distance between the trees upon crab stocks is 18 feet, tree from tree. The trees upon paradise stocks for removal are planted at 9 feet from the crab stocks. The trees upon paradise stocks will produce a good supply of fruit before the other trees upon crab stocks come to full bearing. Some may think the distance between the crab-stock trees too little. No doubt they would occupy a greater extent in course of time; and the same distance is very proper for trees upon paradise stocks. My reason for having them so near to each other, is, that I never see old trees produce fruit so good as young trees, neither in size nor quality, and very often not so many in number, and it is easy for every gardener to keep a succession of young trees.

In an arrangement of fruit such as the above, the ground between the rows is nearly as useful as without trees, and it will answer for any kitchen crop, pease and celery excepted. The better the garden is manured for vegetables, it is still in favour of the trees; they will produce the finer fruit, both in size and quality.

The height of the stakes at five feet (as in former plan) is a proper height, when the distance between the rows of trees is eight feet. If the stakes or rails be higher than five feet, the distance between the rows must be greater in proportion, to keep the one row from shading the other.

The above method can be put in practice in a large garden, or in a small one, with equal advantage, in proportion to its extent.

There are cherry trees, and plum trees, of sorts, planted in Ballindean garden upon the same method as the apple trees. Pear trees may, with equal advantage, be planted upon the same method, only taking care to place them at the distance of 25 feet, tree from tree, in the rows. If the pear-trees be worked upon quince stocks, it will be in their favour, particularly the strong growers.

From this paper, and its accompanying draught, it will be seen, that the Horticultural Society can have planted in their Experimental Garden a very great number of different kinds of fruit trees upon a very small piece of ground; and they need not be afraid of having their trouble amply repaid. The specimens of apples sent from Ballindean last September to the Society's Festival, will in some respect give them an idea of the quality of fruit thus produced.

I may mention, that even the farmers in this neighbourhood are practising this economical method of planting fruit-trees, from seeing its good effects at Ballindean.

BALLINDEAN, }
16th Nov. 1826. }

Note by the Secretary.

The specimens alluded to by Mr Dick, as sent to the Society's Festival last September, excited general admiration, being equal in size and colouring, and superior in flavour, to the generality of apples produced on wall-trees in Scotland. The season 1826, no doubt, was remarkably favourable for espalier-rail and standard apple-trees; but the fruit produced in Mr Dick's economical compartment, has for several years maintained its high character. It may be proper to add, that, at a meeting of Council held on the 4th January 1827, the Society's Silver Medal was voted to Mr Dick, for devising this advantageous mode of arranging dwarf fruit-trees in a garden.

V.

*Description of an Economical Pit for preserving
Vegetables and Salads during Winter, and
raising Early Vegetables and Salads in the
Spring.*

By Mr ALEXANDER STEWART, Gardener to Sir Robert
Preston, Bart. Valleyfield.

In a Letter to the Secretary.

(*Read 10th December 1817.*)

SIR,

FOR these some years past, I have made use of straw-covers, laid over a temporary frame, to protect our tender vegetables and salads. This I have done with a view to save our glass-frames, which are too often destroyed in the winter months, when used for that purpose. I have found the straw-covers to answer the purpose so well, that they have led me to the construction of the pit I am about to describe.

The size of the pit made at Valleyfield, is one hundred feet in length, three feet and a half in breadth; twenty-two inches deep in front; three feet at the back, all inside measure, and below the surface.

The covers are made with wooden frames, filled with straw, in the following manner:—Take two pieces of wood, two inches thick, and four feet long, or according to the width of the pit: these form the sides: then take four pieces of wood five-eighths of an inch thick, three inches broad, and three feet long; nail them across the two former pieces, one at each end, and the other two at equal distances; then turn it upside down, and fill up the space with straw, laid as straight and close as possible; nail on the upper side the same number of bars as on the lower side, which keeps the straw firm and tight. But in case of the above description not being sufficient, I shall send one of the covers, with a rough sketch of the pit, (Plate III.)

At present, the pit is filled with Cape broccoli, cauliflower, lettuce, endive, and a few cauliflower plants. In the spring, I propose to raise early radishes, lettuce, potatoes, French beans, cauliflower plants, celery, some of the half-hardy annuals, or any other vegetables that may require to be forwarded: and during summer, I intend to fill the whole with cucumbers for pickling, tomatoes, or any other tender vegetables. But, for the satisfaction of the Society, should they think it worthy of their attention, I shall keep a journal of the different crops that are protected through the winter, and of such also as are raised in the spring, so that they may be the better able to judge of its utility.

My object is to protect the tender vegetables

which would otherwise be lost during the winter, and to forward them in the spring, with the least possible expence and labour, which has induced me to call it the Economical Pit.

In this country, we seldom have a continuance of severe frost for more than a week or ten days at a time; and, should it continue longer, if the pit is properly attended to, that is, by giving it an extra covering with stable litter, or any other substance that is most convenient, so as to exclude the frost, there is little danger of the vegetables suffering during that time. When the weather is mild, it is necessary to give as much air as possible, by setting up the covers with proper tilts; but in rainy weather, they must be lowered a little on the tilts, so as to prevent the rain from beating in upon the plants. It will be necessary also to close the pit in every night, during winter and spring, until there be no longer risk from frost.

The cost of the pit, as above described, does not exceed £4 Sterling. The sides are built with rough pieces of stone, from six to nine inches thick, and finished with a turf along the top, in place of a wall-plate: the pit is then filled with the decayed leaves of tree, or old tan, so as to raise it to a proper height, suitable for the plants or crop intended to be put into it. For lettuce or endive, I generally lay a thin covering of rich mould upon the top of the compost, to plant them in: the cauliflower and broccoli are planted in the leaf mould, and raised as

high in the pit as the cover will allow. It is to be understood that the cauliflower, broccoli, and endive, for winter use, are lifted from the different quarters of the garden, and placed in the pit during the months of September and October, according to the season and other circumstances. In placing them in the pit, care must be taken to keep them as close together as possible in the rows, but at the same time to allow a small space between, to admit of a circulation of air, so as to prevent their damping off. Another necessary precaution, is taking off any decayed or yellow leaves that may appear.

I should not have troubled the Society with these observations this season; but the advantages I have already experienced from the few covers over the frames above mentioned, make me desirous that it may be tried in other parts of the country, to prove its effects. Such a pit is within the reach of any possessor of a garden; and is, I think, particularly adapted to the market gardener. I am, &c.

VALLEYFIELD, }
29th Nov. 1817. }

Additional

Additional particulars, communicated in a Letter from Mr STEWART to the Secretary, dated 27th November 1818.

AGREEABLY to the request of the Society, I now send you some further particulars regarding our vegetable pit. As it was cleared of the winter stock, that is, the Cape broccoli, cauliflower and lettuce, I began with a few early pease, beans, cauliflower, lettuce, radish, and potatoes. These were sown on the 18th of February; the radishes were fit for table on the 18th of April; the potatoes on the 20th of May; and the other vegetables in proportion. It must be observed, that there was no bottom-heat applied, and that the situation of the pit is high, and exposed to a cold current of air. Were the pit placed in a more favourable situation, I have no doubt they would have been much earlier; but, as it is, they were full three weeks before the crops in our sheltered borders. In the beginning of April, as the remainder of the pit was cleared, we sowed celery, ten-week stocks, French and African marigolds, China Asters, and a few kidney beans, all of which were much earlier than those sown in the open borders, and made better plants than those raised under glass. When the

spring crops had been cleared, they were succeeded by ridge cucumbers for pickling; but the pit was first cleared to the bottom, and then filled with cut grass and litter, to cause a slight heat, sufficient to establish the young plants turned out. The whole of the crops so raised succeeded beyond my expectation; and I have no doubt but that such a pit will give satisfaction to those who may think proper to give it a trial. It is obvious that thus the table may be supplied with the best tender vegetables until the end of February, which otherwise must be protected under glass, or entirely lost.

I have only farther to mention, that, since I wrote the first letter to you on the subject, we have made another pit of nearly the same size, and have continued to use both ever since, much to my satisfaction. They are in fact convenient for so many purposes, that it might be considered tedious in me to enumerate them. I shall, therefore, with the notice of one more, close the subject: Dahlias potted and set in these pits may be forwarded a full month before turning them into the borders; and of course other tender plants may be treated in the same way. In this place, I never consider it safe to risk our tender annuals in the common borders, until after the first of June; therefore, without such a convenience, I should be much at a loss.

ECONOMICAL VEGETABLE PIT.

Fig. 1.

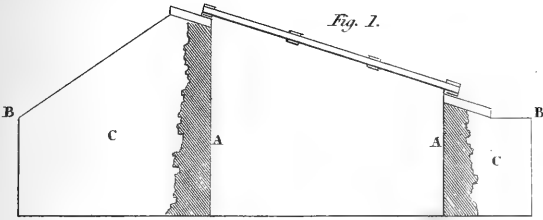

Fig. 2.

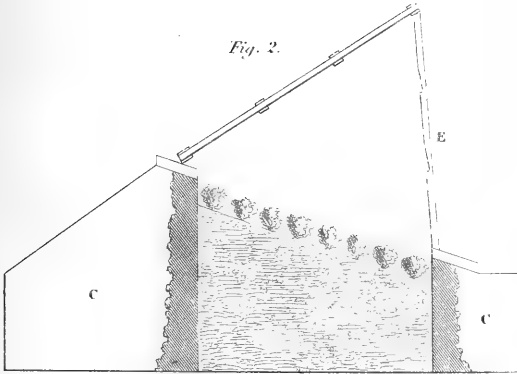
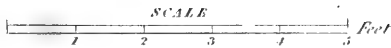



Fig. 3.



Explanation of Plate III.

- Fig. 1. The section of the pit covered.
- Fig. 2. The section of the pit with the cover set up to the full extent, shewing a row of Endive.
- Fig. 3. Shews the upper side of four covers.
- A, A, The stone building on each side of the pit.
- B, B, The surface on each side of the pit.
- C, C, The earth.
- E, The tilt, with two notches to lower the cover on in wet weather.
- N. B.* The cover sent to the Society has a piece of wood up the middle, which keeps the straw more firm, and will allow the covers to be made four feet wide.
-

NOTE.—At a meeting of the Council held on 1st February 1827, and upon a report from Mr Macnab and the Secretary, the Society's Silver Medal was voted to Mr Stewart for his Economical Vegetable Pit, as an improvement which has now stood the test of more than ten years.

VI.

*On the utility of employing Grass Turf or Sward,
in forwarding Early Crops of certain Vegetables.*

In a Letter from Mr ALEXANDER BISSET, Gardener at Methven Castle, to the Secretary.

(*Read 1st June 1826. **)

SIR,

I NOW offer to your notice the promised communication, relative to a new practice, which may be employed with advantage, in various cases, but more especially in promoting the early ripening of peas, potatoes, beans, &c. In order to afford an immediate proof of the advantages that may be derived therefrom, I take the opportunity to exhibit specimens of early summer peas, which were thus early brought to maturity by means of the mode of practice above alluded to. They are already perhaps rather over ripe, and would have been in higher perfection for the table a fortnight ago.

* At a General Meeting held on this date, the Society's Silver Medal was voted to Mr Bisset for this improved practice.

It is allowed by those that are conversant in horticulture, as well as by all who are acquainted with the nature or quality of soils, that grass-turf or sward, in a more or less decayed state, is highly conducive to the growth and health of plants. Hence it occurred to me some years ago, that turf might be employed upon a new principle, with advantage, in promoting the early production of a first crop of peas. I therefore took the first opportunity of putting my plan into execution; and I have now the satisfaction to state, that, in the course of my practice for several years past, I have done so with success.

Early Peas.—In pursuing this mode of practice, for the purpose of forwarding early peas, it is necessary to have a quantity of well matted grass-turf or surface sward secured previous to the winter, so as to be in readiness, in the event of a fall of snow or severe frost happening at the time of sowing, which is about the middle or towards the end of January. The turfs may be cut in pieces of about nine or ten inches broad, and a foot or fifteen inches long, to be afterwards reduced in size. The tops of flues, and the borders of forcing-houses, may be appropriated for the purpose of receiving these turfs, having the peas sown on them; or framing-pits of any description may very conveniently be used for the purpose, being generally unoccupied at this season of the year. The application of bottom heat will in this

case be found necessary, particularly if the winter be severe. In order to effect this, so as not to produce an over-heat, I generally employ a mixture of stable-litter and tree leaves, such as may have been previously used in the forcing of sea-kale or asparagus. While the gentle fermentation of such a bed assists in keeping out frost, it will be found of evident advantage in germinating and afterwards promoting the growth of the young peas.

The beds being thus prepared, a quantity of the turf is then cut into pieces of about nine or ten inches long, and five or six inches broad. These are placed in a regular manner over the surface of the beds, grass-side downwards. If the turf be taken from land of an inferior quality, it will be found of the utmost importance to add a little rich loam to the soil thereof, forming at the same time a shallow drill along the middle of each row of turf. A row of peas is then sown in a regular manner in each drill, and afterwards slightly covered with rich loam.

While the peas advance in growth, their roots, it is evident, must penetrate and take possession of the turf; and the turfs and growing peas may together be lifted and removed to a south border, where the peas are to produce their crop, without the plants sustaining the least injury in being transplanted. This I regard as an improvement of the greatest importance. By the beginning or towards the middle of March, the pea plants on the turf will have reach-

ed to the height of five or six inches, and will therefore, on account of the smallness of the space betwixt the rows, require to be either wholly or partially removed to the south border, where they are to produce their crop. In general, it will be found of considerable advantage to remove in the first place every alternate row only, and to allow the remaining part to advance in growth till they begin even to show their flowers. The pea plants, at that late period, may notwithstanding be removed to the place where they are to produce their crops with perfect safety. By this means, the ripening of a crop of peas is more speedily promoted; for the plants last removed afford the first supply for the table; and a succession of young peas is thus obtained from the same sowing. At this early period of the season, it will invariably be found necessary to use means for protecting the peas from frost, immediately after being put out, especially if they are near the flowering state; for this purpose, beech and spruce branches, or straw-ropes, may be employed with good effect. In adopting the mode of practice above described, young peas for the table may be had in abundant succession generally in the end of May, or, at all events, by the beginning of June, even after a very unfavourable winter, in every gentleman's garden throughout Scotland.

But in order to ensure an early crop of peas, in this as well as in other similar cases, care must be taken to select a good early sort, otherwise all our

additional labour and attention will in a great measure be lost. The kind of pea which I consider the most valuable and best adapted for the mode of culture here recommended, is *Nash's early frame*. The specimens which accompany this communication are of that variety. This excellent pea is sold under the name above mentioned by Messrs Dickson and Turnbull, seedsmen, Perth. I may add, that *Bishop's early dwarf* is much to be recommended as an early pea, and is also well suited for the same mode of culture.

Early Potatoes.—Having thus given an account of my new practice in promoting the early ripening of peas, I consider that it would be altogether unnecessary to enter into a full detail of the practice, when employed for the purpose of forwarding early potatoes, it being similar to that employed for the peas in most respects. The only difference which may be particularly specified, is this:—The turf for a potato crop is cut into pieces of about three or four inches square: these are placed in a close irregular manner over the surface of the beds; and only one tuber or cutting planted in each piece of turf. This should be done about the middle of February; and, by the time the potato plants have reached to the height of three or four inches, it will be found necessary to remove them to a sheltered and south-aspected border, where they are to produce their crop. But it may here be observed, that, as the application of

bottom-heat is in this instance essentially necessary, another desirable point may, without any additional labour, be gained; for, while the greater part of the potato plants may be removed with safety, and transplanted into the open border, a part of the plants may be left in the pits, in such a manner as if they had been planted therein, for the express purpose of producing their crop. This being attended to, new potatoes may be had occasionally for the table, after the middle of April; whilst a succession from the same plants may be afforded, by the middle or towards the end of May.

Beans.—A similar mode of treatment to that employed for the potatoes, will be found applicable for the purpose of forwarding early crops of *Common Beans* and *French Beans*, particularly the latter. But it is requisite that three or four seeds be planted in each piece of turf, and that the proper season for planting be taken into consideration, according to the nature of the crop.

Early Cauliflower.—Turf may be employed with advantage upon the same principle, for the purpose of forwarding *early cauliflower*: and it may be mentioned, that, with the exception of the cauliflower being planted in the turf, the treatment is in every respect the same as that which is generally adopted in this part of the country for preserving cauliflower plants during winter. It is well known to every prac-

tical gardener, that a compound of sward and surface soil in the process of decay, is peculiarly conducive to the growth and health of cauliflower plants; and it is evident that turf may thus be employed with much facility and advantage, for the purpose of forwarding, early cauliflower, as in the following spring the plants may be allowed to remain under glass till they attain to a large size, and may nevertheless be removed and planted in the open border, without injury, or risk of checking their growth, as being completely established in the turf, which is moved along with the plants.

Strawberries.—Upon the same principle, turf may be employed with advantage in the forcing of *strawberries*, by means of which the use of pots might be altogether dispensed with. This will be evident from the following description. At the proper season for planting the strawberries, let a small piece of ground be formed into beds about four feet wide, and a quantity of turf be taken and cut into pieces of about five or six inches square, which should be placed in a regular manner over the surface of the beds. A quantity of fresh loam, richly manured, should uniformly be applied to the surface of the turf, previous to planting. And in order to furnish large stools, four or five plants should be separately planted in each piece of turf. This may be done to best advantage in the early part of the spring season, with plants taken from

the runners of the preceding year; or, it may otherwise be accomplished with good effect in the end of summer, with plants selected from the runners produced the same year. If due attention be paid to watering in dry weather, the plants will be found to grow vigorously, so that, by the end of the autumn season, their roots will be fully established in the turf, and they may therefore be removed to the forcing-pit with nearly as little injury done to them as if they had been planted in pots. It will be readily perceived, that, in this case, the strawberry plants, with their roots in possession of the turf, must of necessity be planted in a ball of earth or decayed compost, prepared in the forcing-pit appropriated for that purpose. In regard to the kind of strawberry fittest for our purpose, I may mention, that, among the various kinds that I have yet become acquainted with, I consider the *roseberry* the most valuable for the turf mode: though it can by no means be allowed to be the earliest, nor the best in point of flavour, yet it is a strawberry which invariably yields a plentiful crop even the first season after planting, which, independent of its other properties, renders it a most appropriate strawberry for being forced. But it may nevertheless be stated, that all such kinds of strawberries as are capable of being forced with advantage in pots, may be done so likewise with turf; for, if it be taken from a stiff soil, it will last for two years; and at the end of that period, it will still be found to possess its adhesive or binding properties.

Before concluding, allow me to remark, that the employment of turf upon the same principle, will be found of no little importance in the management of the flower-garden. By sowing and transplanting *showy annuals* of a half-hardy character on patches of turf, they may be forwarded at the commencement of summer by means of a little bottom heat, assisted with a covering of mats during the night; and they may be removed and planted out in the flower-borders at any stage of growth, without receiving the least check. The same practice may be followed with the more tender kinds of stocks, wall-flowers, &c. by sowing or transplanting them at the proper season, and keeping them under shelter during winter, which, in the following spring, may be removed and planted in the flower-borders with perfect safety. I am, Sir, yours, &c.

ALEX. BISSET,

METHVEN CASTLE, }
28th May 1826. }

VII.

*Observations regarding the Management of Oak
Coppice-Woods, &c.*

By Mr ROBERT HOSIE, Gardener to the Right Honourable
Lord LYNDOKH.

(*Read 1st June 1826.*)

THE planting of oak for coppice-woods, in this country, has been carried on for these some years back, with great spirit, so much so, that there is a probability of its being over done ; however, it will always be in the power of the proprietors, if that should come to be the case, to let more shoot up for standards, to remain till they are fit for ship-building or other useful purposes, when they must always become valuable while the nation maintains its commercial greatness ; besides, no tree surpasses the oak in what is called picturesque effect, or adds more to the general beauty of a country.

The sketches in the annexed engraving (Plate IV.), are meant to represent about an English acre each, with 432 plants, at 10 feet distance from one another.

Sketch 1st shews three groups of standards, containing altogether about 60 trees, left at the first cutting, at the original distance of 10 feet, and supposing them of 25 years' growth.

Sketch 2d is meant to represent the same plantation, 50 years old, with the groups thinned out to half the number of the former.

Sketch 3d supposes 75 years old, or third cutting, with 9 trees left ; and sketch 4th is 100 years, with only 4 remaining of the first planting ; but two new groups for standards are allowed to get up, containing 25 trees ; which, of course, ought to have been training during the growth of that cutting ; and, at the next, another group may be left, when some, if not all, of the old standards can be taken away.

Leaving standards in groups (instead of the same number regularly scattered over a wood), is by no means new, but probably was at first thought of, rather to avoid the formality of regular distances, and with a view to picturesque effect, than from an idea of profit ; but, for a coppice-wood, where a considerable number of standards are wanted, the advantage is very obvious ; for instance, if 60 trees were left regularly over an English acre, the distance would be about 26 or 27 feet, which is too close for coppice-wood to thrive with that number of standards ; on the other hand, if 60 trees were left in groups, as represented, it would leave at least five-sixths of the acre perfectly clear : but the number left might depend upon the extent and form of the wood. The

Fig. 1.

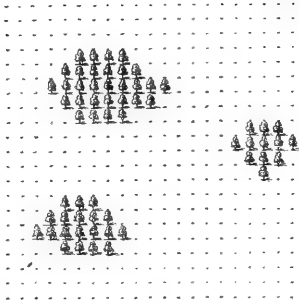

Fig. 2.



Fig. 3.

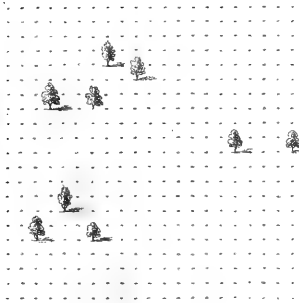

Fig. 4.

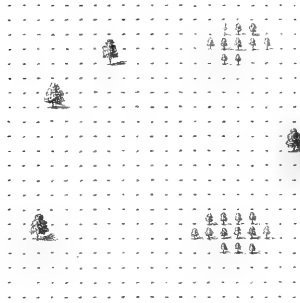
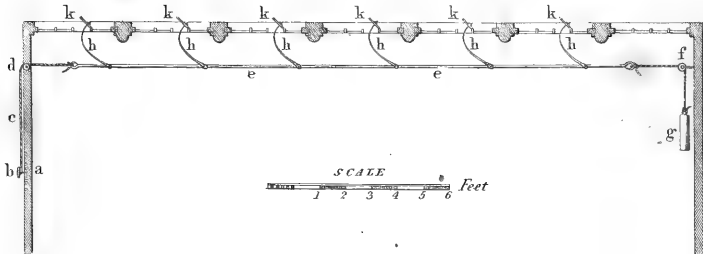

Fig. 5.





thinning the groups at the age of 50 years, instead of leaving that number at 25 years, I think would ultimately pay better than if only 30 had been left ; as, in that case, with only that number, the coppice within them would be of little value, while the standards, if at the distance of 10 or 12 feet, at the age of 50 years, would greatly surpass in profit any thing that could be made of coppice-wood. I know it is thought by some that 10 or 12 feet is too great a distance to plant for coppice-wood : in a great measure, this must depend upon the quality of the soil, or fitness to grow oak luxuriantly ; as I have reason to think that a poor soil, or one not of a nature to give a very weighty crop, would require to be planted thicker than one of the first quality. Probably 12 feet might be the most advantageous distance for the latter ; but, in general, I should think 10 feet a very proper distance. This is about 450 plants to an English acre ; and I have no doubt but that, with an equal soil and situation, the produce would be better than if double that number had been planted, or even 700, which is about 8 feet apart, as recommended in a book lately published. It would no doubt require long experience and observation to say positively what would be the most advantageous distance to plant at ; nor have I ever heard of it having been fairly tried : but, by reasoning from analogy we find, that, both in horticulture and agriculture, there is a certain distance that will produce the greatest weight of crop ; if too great, the ground

is not altogether occupied, and if too close, the plants are choked up for want of air. It is only by examining the distances in the most thriving plantations, that we can form any thing like a correct notion of the subject; but, from any observations it has been in my power to make, I should certainly prefer 10 feet to 8 feet. Besides, the greater distance leaves more room for underwood, such as hazel, &c. which, in some places, is found to be nearly as profitable as the oak. At the distance of five feet, the underwood would be thick enough at double the number of oak stools; while, from 10 to 12 feet, you might have three times the number.

In forming plantations in general, it has very justly been considered by proprietors, that lands, not adapted to tillage or pasturage, are the most beneficial both to themselves and the community at large for that purpose, although no doubt the better the soil and situation, the better they will thrive; but it is found that oak will succeed tolerably well in a great variety of soils and situations, from bare moorish lands to rocky precipices.

It has been recommended as a most advantageous way of rearing woods, to sow them at once upon the spot where they are ultimately to remain, particularly the oak, as it would not disturb what is called the tap root. Having tried that method, both with regard to oak and the pine tribe, it was found most decidedly not to be the most profitable way; and, as to disturbing the tap root, it will be found, by who-

ever takes the trouble to examine, that it is only to a certain depth, and where the soil suits, that it takes a perpendicular direction, a horizontal one afterwards being the most natural. As to the difference of expence betwixt sowing and planting, let it be considered that, within the compass of a few square yards, as many trees can be raised as would plant some acres, and at a trifling expence; while, by sowing a large plantation at first, the extra expence of seed alone would nearly counterbalance that of planting, besides other disadvantages, such as the young plants being thrown out by the frost, particularly the pine tribe, and the loss of the growth of a year or two, which may be saved by planting stout plants.

I have no doubt that, for an oak-wood, the most profitable way is to get stout plants, if possible, of two or three feet high at first planting; but, in making up an old plantation, if they are 4 or 5 feet high so much the better.

I would by no means recommend the practice of pruning the roots and branches of young plants much before they are planted out; if they are from 1 to 3 feet high, very little pruning will do. It may be convenient to shorten a very long tap root, or cut off a lateral shoot that is unproportionably large for the size of the plant, which is all that will be of any use; for pruning, at that size and age, can have no effect upon the future form of the tree, as some imagine. Whoever attends to the growth of young plantations must observe, that it rarely

happens that what is left for the leading shoot at first planting, ever becomes so. No doubt it is necessary, with trees of a large size, to prune the branches considerably to prevent wind-waving; and it will be found impracticable to plant them, without cutting the roots in some degree likewise; but the more fibres that are left, in both young and old, the better. To form handsome trees in extensive woods, and without retarding their growth, in my judgment, pruning with a large knife, 7 or 8 years after they are planted, when they begin to grow vigorously, is the best way. At that time a leading shoot can be made sure of, and is perhaps all they would require. The stools of a coppice-wood can be pruned and thinned in the same way, by leaving two or three of the most vigorous stems upon a stool, and thinning their side branches. The great object in thinning coppice-stools, is to leave such strong shoots that none of the others that may afterwards spring from the same stool will ever be able to contend with them. The pruning of all the lateral branches, great and small, up to a certain height, as is practised by some, I think a bad plan; it is not the way to form handsome trees, and in general gives such a check to their growth that they are some years before they recover. Indeed it requires a delicate hand to prune, without, in some degree, retarding their growth; and it is very doubtful to me if the pine tribe ever should be pruned at all, unless in taking off the dead boughs; but if

it is necessary to prune the live branches, they should not be cut too close to the stem at first, but left as snags, and cut close afterwards, when the sap is gone. If it is wished to form handsome trees of oak, or other deciduous sorts, in parks, where they are exposed to the winds, no doubt they will require to be pruned oftener than those confined in a wood, but they should be pruned upon the same principles.

It often happens, particularly at the first cutting of an oak-coppice, that a considerable number of the stools do not shoot the first year, and sometimes not even for two or three years afterwards, and these generally the healthiest of them. At first I thought this might be owing to the lateness in the season of cutting them, which no doubt, in some instances, may be the case; but I found that this did not altogether account for it, as some, cut both early and late, lay dormant. It is easy to account for stunted stools not being so liable to push as healthy ones (although they seldom fail, if cut at the proper season), as the shoots in the former are apt to form buds all over the bole, probably by the stoppage of the sap from disease, and of course are sure to shoot that season, if they be not very late indeed in cutting. As the loss of two or three years' growth, if the number of stools are considerable, must be of consequence, it would be very desirable to find some way of preventing it. We find that trees which are deep planted are most

liable to lie dormant, although this may also happen with those that are shallow planted ; but deep planting may be considered as the main cause. Therefore, if care were taken to remove the earth from the roots for a little way round the stem, immediately after cutting, it would enable the shoots to get up. I have no doubt but that in general would answer the purpose. It can by no means be owing to the mode of cutting, as some may think, as it appears to me to be of no consequence by what tool the stems are cut, whether by an axe or a saw, so as they are cut low : as the young shoots generally spring from betwixt the angles of the large roots or fangs, so the lower down they come the better ; for, when they spring from the root itself, they produce the most luxuriant wood. As to what is called dressing the stools, I have every reason to think it is quite useless ; it is no doubt meant to prevent that part from rotting, which it will not do. In general, the part of the stool near the surface, or what is above ground, will decay long before next cutting, although, in some very few cases, where it is left high, and the shoots spring from the top, it may in some measure be preserved, although in an unsound state ; but I by no means think it a disadvantage for that part of the stool that is above ground to rot soon, as in that case the new shoots will be sure to come from the roots.

In soils and situations that will suit, it is generally thought that larch is more profitable to plant

than oak ; but in very extensive woods it might answer to have both,—the larch in large masses and irregular groups upon the most elevated places, and the oak as the main body of the wood. It would correct the formality of a regular plantation of larch or fir; as we find that plantations of the pine tribe, however extensive, and whatever may be their height, if they be all planted about the same time, have no better effect in distant landscape than furze or broom. It is only by breaking them into detached masses and groups, leaving the spiral formed upon the highest places, and introducing oak, or other round topped trees, that the pine tribe can be made subservient to beauty.

It has been the opinion of some, that, by attending to the various colours of the leaves of the different kinds of trees, they might be so arranged as to greatly vary the effect ; but I should think this but fanciful at best. It is well known, that it is not so much the different colours, as the lights and shades of a picture, that give the effect: a beautiful one may be drawn in Indian ink without any variety of colour : And the same may be said of a plantation : the trees may be all of one sort, and yet have a most picturesque appearance, by the lights and shadows they throw from their broken masses, irregular groups, and unequal heights, and likewise by means of the prominent points and recesses of the outline ; although it would be impossible to give the same beauty and cheerfulness, to a plantation composed

altogether of the evergreen pine-tribe, as could be given to one composed of oak; and it must be admitted, that, in the colour of some leaves, the contrast is so great that they do not associate well together. Probably, in a shrubbery, an arrangement upon the principle of the colour of foliage might have a good effect, where the point of view can never be at any great distance.

Some attention of late has been paid to the planting of hedge-rows. There can be no doubt, but that oak, in this country, is by far the best for that purpose, both for ultimate profit, and doing the least damage by their roots to the adjoining crops. Besides, no tree adds more to the beauty of the landscape, than the oak does in that way, provided the trees be not made absolute hedge-rows: it requires but few to give the proper effect, and those very irregularly interspersed. Besides, when planted regular and thick, they will no doubt injure the corn crops, by preventing a due circulation of air. But there can be no exact rule laid down for the distance, as some situations will require more, and some less. The only rule, I think, upon a large estate is, to allow enough for some to be cut yearly in succession, when they become valuable, and the stool to be then trained to one stem only, while others may be left to grow to a large size, and be then cut so as in no case to have a bad effect upon the general landscape. The size of the young oaks, when planted, may depend upon the age of the hedge; an old hedge re-

quiring taller plants than a young one. For a young hedge, oaks might do well at three feet high or so, to be planted along with it; while an old hedge will require oaks six or seven feet in height, to put them beyond the reach of cattle.

Hedge-row trees planted in the open and irregular way recommended, if to a great extent, would give a lightness and beauty to the scenery of a country, far superior to the formality of thick planted regular hedge-rows, and without doing any injury, by shading the crops or robbing the soil, while they would ultimately afford a fair profit to the proprietor.

VIII.

*Account of an Improved Mode of Ventilating
Hot-Houses.*

In a Letter from Mr JOHN TWEEDIE, Gardener at
Eglinton Castle, to the Secretary.

(Read 2d December 1824.)

SIR,

THE advantages to be derived from my improved mode of ventilating are numerous. In the articles labour and preservation of glass, the saving may safely be rated at from 30 to 40 per cent. A man or a boy may, with one hand, remove all the hatches in three or four seconds, though the house were two or three hundred feet long; whereas, in moving the sashes in the common way, it would require a man, in some cases, from twenty minutes to half an hour each time, to perform the same operation. Besides, by moving such a large proportion of the roof, the weight and motion loosen and destroy more or less of the glass almost daily.

Being limited by the construction of our old houses here (Eglinton Castle), in applying the above plan,

its advantage has not been so completely evinced as it might be, when adopted on the first construction of a hot-house; for, in the first erection of a hot-house roof, with ventilating hatches, a great proportion of the expence might be saved, not only in the appendages already mentioned, but the bearers, also, if not entirely excluded, might be constructed so as to have less shade, and have a much neater and lighter appearance.

If the plan (Pl. IV.), and these suggestions, are considered worthy of publicity in the *Memoirs of the Caledonian Horticultural Society*, you have my permission.—I am, &c.

EGLINTON, }
1st October 1824. }

It is observed by a late writer on Horticultural subjects, that the many various modes and structures employed in practical gardening, particularly in the erection of forcing-houses, shew, that there is perhaps not so much as a single hot-bed properly constructed; and we see, that, in every recent establishment of that nature, there is always something new introduced by way of improvement. I have been for upwards of twenty years employed among hot-houses, to a considerable extent, both in Scotland and in England; and I have seen several methods employed for airing or ventilating them, few of which have ever been so general, or reckoned so

convenient, as the sliding-sash. To me this last always appeared a cumbrous and an expensive method, far inferior to some more convenient and economical plan yet to be devised. In large houses, where the sashes are perhaps from ten to fifteen feet long, and from three to four feet broad, there are to be moved about forty superficial feet of sash, with its numerous appendages—two or three lines of cordage, spring-latches, plates, rollers, pulleys, sash-grooves, &c. to each sash; and all this for the sake of giving, perhaps, only from half a foot to two feet of air-vent. Besides, some of this complicated apparatus is constantly getting into disrepair, and the ever-fluctuating extremes of heat and cold, damp and drought, incident to our climate, subject the whole plan to numerous objections. To obviate these defects, as far as possible, has long occupied my attention; and, after trying various methods, I have now fixed upon one, which, I think, will be found to unite convenience, neatness, and utility.

Annexed (Plate IV. fig. 5.) is a plan of the ventilators, to which I here refer, and which I have for several years past employed at this place for hot-houses of various dimensions; and I have invariably found them to answer my warmest expectations.

In the plan, where the ventilators are shewn in a half opened state, *a* represents one of the upright stiles, or door-posts, in the end or section of the

hot-house ; in which are pierced several sockets, six inches distant. Into these sockets, an iron hand-pin, *b*, is introduced, regulating the whole apparatus, by being moved upwards or downwards, from socket to socket, by the hand, according to the various degrees of air-vent wanted. This iron pin is fixed to a cord, or chain, *e*, passing through the stile *a*, over the pulley *d*; which cord, or chain, is fixed to an iron rod, *e*, *e*, having an axle-joint at the junction of each lever. The rod, when the hand-pin *b* is moved up or down, moves horizontally between the pulley *d*, and a pulley *f*, fixed to the corresponding stile at the other end of the house, by the action of a weight *g*, attached to the end of the rod by a cord or chain, passing over the pulley *f*. This horizontal rod *e*, *e*, in its motion, thus produced by the weight *g*, operates at every joint, as already mentioned, on bent levers *h*, which, being attached to hatches, *k*, lift them or lower them, so as to admit or exclude the air, as circumstances may require. The upper end of the lever is fastened to the hatches by screw-nuts, in order that, by unscrewing them, the sashes may be freed from the levers, and removed at pleasure for repair. The hatches occupy the place of two, three, or four panes lengthwise, at the top of the sash, proportioned to the dimensions of the house, and are hinged upon one of the astragals, projecting both at the sides and the ends, to exclude the wet.

I may remark, that at first I employed iron-rods at *e, e*; but, in houses more recently constructed, I have employed common jack-chains, in place of such rods; the chain being much more easily fitted to the levers, and answering, in other respects, equally well.

IX.

Queries relative to the Sowing, instead of Planting, of Forest Trees.

In a Letter to the Secretary from Messrs BISHOP,
BEATTIE, and MITCHELL.

(*Read 8th Dec. 1818.*)

SIR,

THE subject of the report from the Committee for experiments on the Naturalization of Plants, under our northern climate, as published in the 8th Number of the Society's Memoirs*, has been particularly gratifying to a number of your correspondents in this part of the country, whose situations require them to be equally conversant in planting and rearing of timber, as in growing vegetables and maturing fruits.

The very imperfect manner in which much planting is executed,—the treatment of the plants,—the season of planting,—the soil and situation to which many different sorts are improperly subjected,—admit of much to rectify, and in which many valuable

* Vol. ii. p. 416. &c.

discoveries may still be made, equally beneficial to individuals as to the general good of the nation at large.

The advantages that may yet accrue to the public, by the introduction and naturalization of different plants into our country, none can presume to estimate; neither may any imagine that the best method in rearing those valuable species already naturalized, or even those timber trees indigenous to our country, has been fully ascertained.¹¹

It is therefore with pleasure that we have seen the subject taken up for investigation by your Committee, under the auspices of so much talent and public patronage; and we rejoice in the promise given to resume their labours at a future period, from whence we are led to anticipate very important advantages, in rescuing from oblivion the result of many valuable experiments and accurate observations, which may tend to establish a system of planting and rearing, on a sure and practical basis, supported *only* by well authenticated facts.

The right that every one has to speculate in opinions, we are ready to allow: it is only when theories are assumed as patterns for practice, that they become strange lights, and are apt to mislead the unwary; nor are we altogether certain how far your Committee have not indulged themselves in this respect in their section on the *tap-root*, which has induced us to propose the following Queries, that

we may be put in possession of the only certain proofs, which can evince to us the superiority of the principle recommended ; and for the benefit of the public, we would be glad to be answered in some future Number of the Society's Memoirs. We are, &c.

THOS. BISHOP.

WM. BEATTIE.

JOHN MITCHELL.

PERTH, }
9th Oct. 1818. }

QUERIES.

1. Has it been ascertained by accurate experiments, that the tap-root in timber trees has a general tendency to promote their vigour and growth, *after* the third and fourth year of their age ?

2. Can instances be pointed out, to prove the advantage of raising timber, by sowing seeds where the trees are to remain, in preference to planting the same extent of ground with young trees, two or three years old, a year or two later, seeing the practice of sowing muirs and waste lands with seeds of the Scots fir and larch has been long since attempted in Scotland, but without the expected success ?

3. What proofs can be adduced to contradict the result of experiments made in Dean Forest, and ordered to be printed by the House of Commons in the year 1812, from which it appears, that the transplanting of Oak trees in particular, was followed with an excess of growth, far superior to that of others which were never transplanted, the cases of both being perfectly similar?

4. Wherefore should *not* the transplanting of trees, or stopping of the tap-root at a proper age, encourage more the growth of roots in a horizontal direction, which have always a freer range to procure nourishment, and are more likely to be benefited by the influence of the sun and rains, than those which strike perpendicular into a sterile subsoil, and which are the soonest broken by violent winds, when the tree attains much height, as is very observable in larch and fir trees blown over, and which in many cases occasions the rot in such trees, which begins in the root, and proceeds upwards?

5th April 1827.

THE Council recommend these Queries as the subjects of communications, founded on experience, for which Medals will be awarded, according to the merits of such reports.

PAT. NEILL, *Sec.*

X.

Account of a simple and effectual method of destroying the Scaly Insect.

By Mr WILLIAM BEATTIE, Gardener to the Right
Hon. the Earl of MANSFIELD at Scone.

In a Letter to the Secretary.

(Read 6th September 1826.)

DEAR SIR,

I now send you an account of the method which I take to destroy the *Scaly Insect*, with which many of the trees here were infested. I am sorry that I am not naturalist enough to give you the technical name of the insect. It may be the same with that described by Mr P. Barnet in the 2d Number*, or that described by Mr Thomson in the 7th Number † of the Society's Memoirs; but in my experience, neither chamber-ley, nor soap-suds, with the addition of soda, had any effect in destroying them; and I had heard that Mr Scougall's clay-paint did not succeed in destroying them where it had been tried. I could see no other remedy, therefore, but

* Vol. i. p. 182.

† Vol. ii. p. 301.

cutting down or grubbing up the trees, and planting others in their place.

Before, however, proceeding to cut down the trees, I thought of subjecting one tree (a green-gage plum) to an application of boiling water. Accordingly, on a mild day in the month of February, the tree was unnailed from the wall, and, with a painter's soft brush, washed all over with boiling water (at least as nearly to boiling as it could be carried a short distance in a small water-pot). This washing was made over all parts of the tree, without any attempt to avoid the buds, or young wood : the tree was again nailed up to the wall, and allowed to remain. In the spring, it began to shew some blossom, and to send forth shoots, the same as the rest of the trees. I thus soon ascertained that it had suffered no injury from the boiling water ; but at this time I was not so sure that the scaly insects were destroyed.

As the season advanced, I watched the growth of the shoots, to see if any of the insects had got on the young wood ; for usually in former seasons, by the time it was six inches long, it was covered with them, and by midsummer, commonly the fruit also was infested. But on the closest inspection, I could discover none of the scaly insect on either the wood or fruit. This gave me much pleasure ; and I now considered the experiment as likely to prove successful, as the tree, besides being freed of the insects, appeared healthy, and fully as luxuriant as formerly.

The following winter, in mild weather, I had the

whole of the trees* on which the scaly insect was perceptible, washed with boiling water, and have now the satisfaction of seeing them all healthy. The efficacy and safety of this simple application, I therefore consider as established. I may mention, that a very intelligent friend of mine washed with the garden engine in *frosty* weather, and the trees sustained no injury.

It was also my misfortune, like many others, to have the *White Bug* on the trees in the peach-houses here. On witnessing the success of thus washing those trees on the walls, in the following winter I had the trees in the peach-houses also washed, as well as the rafters and walls, in the same manner, and with the like success. I may add, that, as a preventive, I now wash them in this way every winter. The trees are now clean and healthy, they have never missed a crop, nor have been the least hurt by the operation. No one need, therefore, be afraid of injuring their trees by the application of boiling water in the way described. Several of my acquaintance have adopted it with the same success; and I can recommend it with confidence to gardeners in general. I am, &c.

SCONE,
18th July 1826. }

* There were two golden pippin and one Ribston pippin apples, two Crasanne pears, and several green-gage plums. It was on the latter I first discovered the insects.

XI.

*Remarks on the Locust-tree recommended by Mr
Cobbet, with Notices of other more desirable
Forest and Ornamental Trees.*

In a Letter from THOMAS BLAIKIE, Esq. to the Secretary.

(Read 10th November 1825.)

DEAR SIR,

I NOW take up the pen to trouble you with a few observations relative to a publication made by Mr Cobbet, concerning a tree which he calls the Locust*, and the culture of which he eulogises with enthusiasm. He pretends that it surpasses all other trees, and recommends all gentlemen to “destroy the

* I cannot find what is the etymology of Mr Cobbet's name Locust-tree. Mr Cobbet pleases to say that the tamarind is also a locust, and that the pod or fruit was eaten by John the Baptist. This is perhaps a new discovery. Some other commentators have supposed that it was the fruit of *Ceratonia siliqua*, which is a native about that part of the country where St John preached. Still other commentators have regarded the wild locust as a sort of grasshopper, frequently eaten in that country. The name of *acacia* is more significative than locust, for the word *acacia* is originally Celtic, and signifies a sharp thorn or point, and those trees are well armed.

villanous Scots fir, and the infamous elm, and plant nothing but locust." He affirms that no man "in America" will dare to say that he ever saw a bit of the wood of this tree in a decayed state. How far this assertion regarding America may be true I cannot say; but I can assure you I have seen the wood of the *Robinia pseud-acacia* in a rotten state in France; and he admits that what they call in America the locust-tree, is nothing but the *Robinia pseud-acacia* of Linnæus. This tree, I may mention, was introduced into France from America by John Robin, then demonstrator at the King's Botanic Gardens at Paris, and cultivated by him about the year 1600; and to perpetuate the memory of M. Robin, the introducer, the genus received the name of *Robinia*. Of this genus there are upwards of fifteen species known and cultivated in Europe. Several are natives of North America, especially the *R. pseud-acacia* here recommended. This species I have seen cultivated, and have myself cultivated, for upwards of fifty years in France, and have seen it planted in almost all soils and situations. If planted in a rich soil and sheltered situation, it will throw out prodigiously strong and luxuriant branches, and form a large bushy head in a few years; but it seldom forms a straight leading stem; so that those forked bushy heads are subject to break or split off even by light gales, or sometimes merely by the weight of their leaves. In this way those trees are generally disfigured, which has

disgusted many people from planting them. I have examined some of the largest trees of this kind in France, and compared them with other kinds of trees of the same age, and in the same plantations; yet never could I find a fine, tall, straight tree of the *Acacia* once to be compared to a fine straight *Pinus Larix* (larch-tree), or *P. sylvestris* (Scots fir), trees which Mr Cobbet so much despises. If the *P. abies* (spruce) and *P. picea* (pitch-pine) were all destroyed, as he would wish, could Mr Cobbet make ship-masts of his locust-tree? This locust-tree seldom makes a straight stem twenty feet high, unless in a remarkably fine soil and sheltered situation; whereas I have seen larches, and many of the pine-trees, above 100 feet in height, and they will thrive in situations where the locust or *acacia* will not exist; for I always observed, that, in open or exposed situations, it was broken by the wind and mostly destroyed, and that on dry soils it did not thrive. I would therefore advise gentlemen to be very cautious in planting locust-trees, or going to extremes in destroying their other timber-trees, upon Mr Cobbet's recommendation. Some *acacias*, in plantations well sheltered, produce a very agreeable effect from the beauty of their foliage, and the fragrance of their blossom, which nearly equals that of orange flowers: the leaves, however, come late in the spring, and fall with the first frost; so that the tree is divested for a great part of the year of its verdure, and the flowers are but of short duration, seldom lasting in beauty above a week.

In the year 1807, M. Francois de Neufchateau published a little book, entitled, "*Lettre sur le Robinia connu sous le nom improprie de Faux Acacia.*" In this book he speaks with enthusiasm of the acacia, recommends the planting of it in all soils and situations, and even the making hedges of it; and he enlarges on the many uses the wood can be applied to. This high character enticed many people to plant acacias both in the gardens about Paris and in many avenues; so that abundance of seeds of the acacia could be procured within a few leagues of Paris. Most of those I have seen are bushy, low, or broken trees, often disfigured, and not comparable to either elm or oak, or any of our common forest-trees. The branches are covered with strong prickles, so that where wood is wanted (which is a great article in this country), the woodmen exclaim against that of this tree, as they cannot handle it without danger. Few people, therefore, at present think of planting the locust-tree.

There is another species of the *Robinia* cultivated about Paris under the name of *Robinia spectabilis*. This, I believe, is little known in Britain. It is without prickles; the flowers are nearly the same with those of the *pseud-acacia*, but somewhat larger, and a little reddish. This species is frequently grafted upon the *pseud-acacia*, and will thus make prodigious shoots. I saw one of those acacias in a gentleman's garden near Arpa-

jon, which had been grafted upon the *pseud-acacia* in the month of April. The shoot in the month of September following measured 14 feet French measure, nearly equal to 15 feet English, and was tolerably strong in proportion. This was in a sheltered situation. However, I have frequently seen this sort make shoots of from 8 to 10 feet the first year; but this tree is, like the other, subject to split or break.

Some years ago at Mereville, the seat of M. de Laborde, a part of a hill had been planted according to the direction of some pretenders, with acacias, and great progress was anticipated. When I visited the spot, the only remains I could see of this plantation were a few straggling, half-dead bushes. Among the acacias had been introduced by chance or mistake, a plant of *Ailanthus glandulosa*, which had perfectly succeeded, and was now a fine straight tree. The soil was chalky and dry. The rest of the hill was planted with different sorts of pines and spruces, which were healthy, strong, and vigorous, and promised both pleasure and profit to the proprietor; whereas, if the hill had been wholly planted with acacias or locust, it would probably have returned to its former barren state, and the proprietor would have spent both labour and money in vain.

I lately examined some plantations of acacias in the park of Guisard, which had been planted by the Duc d'Aumon about fifty years ago. The most

part of those trees were disfigured, the branches split or broken, and lying upon the other trees. Some of the trunks were decayed and rotten, and rather indicated a decaying than a durable timber; whereas, in the neighbourhood of those trees there were fine and healthy *liriodendrons* above 60 feet high, and specimens of the *platanus* of the same age, with fine trunks. Some of these I measured two feet above the ground, and found to be 12 feet in circumference. Several other kinds of trees were healthy and vigorous, whereas the *acacias* could hardly be said to have become timber-trees. Those locust-trees could never serve to shelter any nobleman or gentleman's country seat, and it would certainly be throwing away money and time to plant them with such views in a northern climate.

The *Robinia viscosa* is a fine flowering tree, and grows to a tolerable size, nearly as large as the other: it is not so subject to break as the two former: the flowers are beautiful, of a red colour, but not so fragrant as those of the common acacia. This was introduced into France by M. Lemonier, and flowered for the first time in his garden at Versailles in 1789. These three species of acacia may be cultivated in sheltered situations, and amongst large growing trees. The *Robinia hispida* is a low growing shrub, very beautiful when in flower, but very subject to break. All these four species of acacia are natives of North America. Their small roots

are sweet, and resemble in taste and smell the liquorice-root ; but I have not heard that the roots have been employed for any purpose. If, after what I have said, people will be led, without reason, to plant these locust-trees of Mr Cobbet, I can easily furnish seeds in any quantity from this neighbourhood ; but if I recommended the sowing of such seeds, I should only deceive the country.

Another tree which Mr Cobbet speaks of with great enthusiasm, is the *white oak*, of which he says the whip-handles in America are made, being much tougher than whalebone, and exceedingly flexible, and bending in every direction. I may mention, that the whip-handles of the coachmen about Paris are made of the *Celtis australis*, and probably equal, if not surpass, his white oak in flexibility. They are known about Paris under the name of *Perpignans*, as the trees grow very plentifully about Perpignan, and they are procured from thence.

Allow me to add, that Mr Cobbet mentions having received the seeds of the *Catalpa*, which he calls a shrub, and ranks it with *Althea frutex*. Now the *catalpa* often grows to above 40 feet high ; and if the *Althea frutex* be, as it ought, the *Hibiscus syriacus*, how happens Mr Cobbet to introduce it from America ? He mentions likewise *Platanus occidentalis*, and I agree that this tree deserves to be cultivated much more than it is, as it is one of the finest and most beautiful trees, and grows to

an amazing size when planted on a moist soil. I saw several of these trees last autumn in the forest at Troy in Champagne, whose trunks were above 100 feet straight, and which, being vigorous and flourishing, will probably come to a vast size if left to grow. I remember to have seen some experiments made with the wood of this tree by the unfortunate M. de Malesherbes, who was a great cultivator of all sorts of trees about forty years ago. When I was at his place he shewed me some cart-wheels he had made of platanus, and others of elm, of which last they are usually made in France. Those made of the platanus were placed with one of elm on the same cart, so that they should have the same work ; and the platanus had outlasted two of elm, and was still in good condition, and seemed likely to outlast the third. This was a clear proof of the goodness of the wood of this tree, which ought to be cultivated both for its beauty and utility ; and if the soil is moist, they will grow to a large size, and become very ornamental.

There is cultivated in France one sort of *cherry-tree* which multiplies very fast by suckers. Without grafting, it produces very good cherries. This sort is in great request in this part of the country : the trees are dwarfish, but often produce great crops of fruit. It appears to be original, and deserving of attention.—I am, &c.

ST. GERMAIN EN LAYE, }
10th June 1825. }

XII.

*On scraping off the Old Bark of Fruit-trees.**

By the late Mr THOMAS THOMSON, Gardener.

In a Letter to the Secretary.

(*Read 10th June 1817.*)

SIR,

WHOEVER will examine fruit-trees that have been planted a number of years, and that have borne crops regularly, must observe that the bearing-branches of such trees are greatly exhausted, having lost their elasticity, the fruit being generally small, and even the leaves no longer having that healthy appearance that is to be seen in young trees. The visible decay in such trees does not appear to be owing to any failure in the roots to form young radicles, to supply the waste of sap which is necessary to carry on the vegetable economy; but seems rather to proceed from the small quantity of

* See postscript to Mr Thomson's paper on the Scaly Insect on fruit-trees, printed in the Memoirs of the Society, vol. ii. p. 305.

inner bark that is formed annually, and the compressed state of the vessels, arising from the hard incumbent bark on the stem and large branches. For I have frequently selected trees that appeared far gone in a state of decay, and, by carefully heading them down, I always found that, in a few years, they formed fine fresh heads, the wood and fruit having all the good qualities of those of a young healthy tree. To apply manure to the roots of such trees, in hopes of renovating them, while the inner bark and vessels remain in a state of compression, can be of very little benefit; for the access is cut off from those parts of the tree that stand in the greatest need of a fresh supply of sap, and until the sap-vessels and inner-bark are relieved, the tree will remain in a languishing condition.

I have found from repeated experience, that scraping off the hard ligneous bark of old fruit-trees has the desired effect of removing the compression, and is useful also in stimulating the young radicles to imbibe a larger portion of sap, so that it ascends more copiously to the upper extremities of the tree, and accelerates the evolution of the buds. From several experiments I have made on leaves, especially those of the vine, I am strongly impressed with an idea that the leaves decompose a certain portion of sap to mature the fruit; for I repeatedly found, that, if I deprived a vine-shoot of a certain quantity of its leaves, it checked the fruit from swelling, and likewise rendered it of an inferior

flavour. I at the same time discovered, by a simple operation, that I could increase the leaves near the fruit to almost double their ordinary size, and that, when that was the case, the fruit was greatly improved in every respect. I am also of opinion, that the leaves are the means of increasing the inner-bark, and of course the alburnum; and as these are the seat of the vital powers, it is reasonable to conclude, that, when so increased, assimilation will go on with greater facility.

To corroborate what I have observed, several years ago I scraped off the outer-bark of two crassane pear-trees. They were planted on a south aspect, and trained in the horizontal form. The stems of both trees were so close to the wall, that about three inches in breadth of the stem was left unscraped. The trees for some years had made very little wood, and the stems were covered with a hard scaly bark. The first year after scraping, they shewed evident signs of the great benefit of removing the hard obdurate bark; for that part of the stem that was scraped had swelled considerably higher than the unscraped part, and in a few years had covered a part of it, for, to all appearance, the unscraped part seemed to remain stationary. The trees made surprisingly fine wood; many of the shoots were four feet in length. I frequently found, in taking off the outer bark of fruit trees, that if I happened to scrape one side, not going regularly round the stem, a fissure would take place a foot

or two in length in the inner-bark ; and it was not uncommon to hear it cracking while going on with the operation.

For upwards of twenty years I have practised scraping off the outer-bark of old fruit-trees, and of most kinds cultivated in this country, and on trees of various ages, and at different seasons. I would by no means recommend scraping off the bark of a young tree while it continues soft and green, for, from what I observed, I always found it injurious to the future growth of the tree.

I look upon the spring and autumn as the best season for removing the outer-bark ; for notwithstanding the greatest care may be taken in scraping off the bark, it will sometimes happen that a wound will be made on the inner-bark ; and as the tree is then in a growing state, by applying a little plaster to it immediately before that the air-vessels shrink, it soon cicatrizes. I often found that a granulation of new bark would take place all over the wound, which seemed to proceed from the air-vessels.

In taking off the outer-bark in winter, the inner bark is liable to be injured to a certain depth, especially if a frost should happen immediately after doing it. It is my humble opinion, that pruning of trees in winter is often attended with bad consequences, particularly in the more delicate sorts of fruit-trees. I have frequently seen very healthy trees that had been hard pruned in winter suffer very

much from canker the season following, and the fruit is liable to become gummy. If a large branch should be cut off in winter, the upper part of the wound is likely to form a cicatrice the early part of the season, which is caused by the descent of the sap. But before that a convulsion of the sap is formed, the cold and wet having pervaded the under part, it generally happens that the bark dies down for a good way, and, if not checked in time, carries the disease to a considerable extent, which is seldom the case if such a branch be cut while the tree is in a growing state.

In order to prepare the tree for scraping, it is necessary to remove the earth from the stem, so as to get as near to the root as possible. I then, with a sharp knife, begin close to the root, scraping off all the hard coating of scaly bark, going a little way into the soft bark below, keeping at an equal depth, that the bark that is left may appear as neat and smooth as possible. And when I have taken off all the bark from the stem and branches, as far as I judge requisite, I have ready at hand a quantity of clay, that has been previously dried and pounded into a fine powder, which, being mixed with water, so as to bring it into the nature of paint, then with a painter's brush I apply the mixture all over those parts that have been scraped, which not only takes off the unsightly appearance of the scraping, but defends the tender bark from the rays of the sun, and likewise from the weather. In a short time

after the tree has set a-growing, the mixture falls off, leaving the bark below of a fine smooth appearance. I am, &c.

NURSERY, }
14th May 1817. }

P. S.—Since writing the above, I have been looking over some remarks that I had made on thinning and pruning of old forest-trees, &c. and there is one which, I trust, you will not think altogether unworthy of your notice.

Having employed a hedger to cut over a strong healthy thorn-hedge, that enclosed a plantation of considerable extent, he had cut over a large portion of it early in autumn, but being called off to some other duties, the remainder was cut over in the winter and spring following. The whole was cut at two and a half feet from the ground, and all done by the same person. I happened to go the latter end of the summer to view the plantation, having thinned it out the preceding autumn, when I was much struck with the unequal growth of the hedge. At first I imputed it to something in the soil, but on examining it more minutely, I found that it was owing to the different seasons of cutting; for the part that was cut in the autumn had made shoots four feet in length, while that which had been cut in winter had made very few shoots, and few of them more than a foot in length. The part that

was cut in the spring was little inferior to what was done in the autumn.—A marked lesson how cautious one ought to be as to the season at which they prune the more delicate sorts of fruit-trees, many of which are foreign to this climate.

T. T.

XIII.

*On the raising of Seedling Ranunculuses, with
an account of some fine ones exhibited to the
Society on 22d June 1826.*

In a Letter from Mr JOHN WATERSTON, Paisley, to
JAMES MACDONALD, Esq. Newington.

(Read 2d Nov. 1826.)

DEAR SIR,

IT was fortunate that the box reached Edinburgh in good order, and that the flowers gave some satisfaction to you and friends. The intense heat, and continued dry weather, put it out of my power to send a great many of the finest sorts, particularly the beautiful red and whites, touched with the pencil of Nature in endless variety, spotted, mottled, laced, and what we term *cherry-edged*. It may be safely asserted, that the flowers wanted at least one-third of the size they reached last year. Had the season been more suitable, perhaps 100 distinct varieties, for the most part superior to those sent, could have been selected from the bed, and not been much missed; for the bed was just one mass

of bloom. I shall proceed to give some of the particulars you desire.

In the year 1821, the seed was saved chiefly from the following sorts of flowers, viz.

1st, *Fleming's fine Mottle*, (or by some called *Shaw's fine Mottle*). This flower produced a greater number of beautiful seedlings than any of the others. In fact, the seedlings raised from it when in bloom for the first time, which was in 1824, more resembled a selection of fine stage-flowers than unproven seedlings.

2d, *Louisette*. This also produced some splendid seedlings.

3d, Two sorts known here by the name of *Duncan's Stripe* and *Hebe*. The seeds of these two sorts put together, also produced a good many beautiful seedlings.

4th, A flower, of which I do not know the name. It is purple on grey. It produced a few choice sorts, among which is one which I have called *Gloria Florum*. This, for beauty, exceeds almost any thing I have ever seen in the ranunculus tribe. The ground is white, strongly edged with a purple colour, inclining to a rich blue, and it is a well built flower.

5th, *Alba maculata* produced some elegant varieties.

6th, *Adam's Spot* produced only secondary flowers, whilst an inferior sort, called here *Shaw's Yel-*

low Spot, produced some first-rate red and purple mottles, rosy and yellow grounded flowers. When they produce sorts so far superior and so totally different from the mother plant, I am apt to ascribe it in a great measure to their being grown near fine flowers, and within reach of their pollen.

The seed was gathered about the end of July, and kept in the seed-vessel, with the stems attached, till about the middle of March following. This was the time of my sowing, but I think it might be done at the beginning of that month. I had some compost prepared in the preceding year for auriculas, the ingredients of which originally were cows' dung, loam, sand, and moss, in about the usual proportions commonly given to auriculas. To this mould I added an equal proportion of fresh sandy loam, taken from the bank of a river. These having been put together for a month or so, and frequently turned over, the soil passed through an ordinary sieve: the coarse parts were reserved for the bottom of the boxes, which were of wood, 18 inches long, 10 deep, and 12 broad, with holes bored in the bottom. About 2 inches of the bottom were covered with the refuse, then 6 inches of the sifted mould, which left 2 inches. I then took a watering-pot with a very fine rose, and completely saturated the earth in the boxes. I next put in about $1\frac{1}{2}$ inches of the same mould, which was previously passed through a very fine sieve: the fine mould soon absorbed from beneath as much moisture as was necessary to

render it fit to receive the seed. When sown, the boxes were put into a small frame of two lights, upon a bed of tanners' bark, containing not above two cart-loads. Not being acquainted with the management of frames with stable-dung, I rather preferred the bark, which I do think is better adapted to the raising of such seeds as those of ranunculus. I had a vessel made of tin-plate, which could contain about seven Scots pints of water. This was so placed in making up the bed, as that it should be covered about eight inches. To assist you in understanding it, I will give you the form.

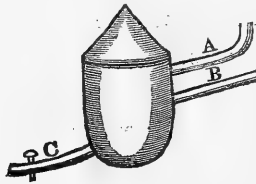

- A, A pipe for filling the vessel by means of a funnel.
- B, Small pipe for letting off the air.
- C, A pipe with a stop-cock for letting off the water.

In the cold evenings this vessel was filled with boiling-hot water, so that, by care, the temperature could be kept up to nearly the heat during the day; but, I confess, this was attended with considerable trouble. After placing the boxes in the frame, I

kept on the lights. The seed soon began to swell with the moisture: in this state it may be ascertained easily whether or not it will successfully vegetate. In some of the boxes I covered the seed very slightly at once; with others I followed the plan recommended by Maddock, of covering by degrees: both ways succeeded equally well. The situation of the frame was such, that, by a high wall about 10 feet distance, it was shaded after about one o'clock P. M., till which time, when the sunshine was strong, it was necessary to cover with mats.

If the seed has been saved from tolerably double flowers, consequently it will not be very strong. The most precarious time is after these weak seeds have vegetated, to get them by gentle degrees accustomed to the air, in order to strengthen them, and make them more hardy. Unless great care be taken, they are apt to go off; that is, many of the tenderest of them die away on air being given. No fit opportunity should be lost to let them receive soft showers of rain, by which they are much benefited. Great attention is necessary from the time of sowing, to see that they never receive a check from drought.

I would particularly warn cultivators to beware of the soil which is used being clear of vermin. That in which I sowed had been lying over from the former year, and the fly, which comes from the common corn-grub, had, about the end of

summer or the beginning of autumn, laid its eggs in great abundance in the mould. After the plants were growing well, the young grubs commenced the cutting them down, so that many hundreds were lost, which, in all probability, would have proved valuable flowers. I would recommend, that all heaps of compost, for any similar purpose, should be covered during the time that these insects are depositing their eggs.

During the first year, the plants will require to be regularly kept moist, and shaded from the scorching sun. At same time, they should receive as much air as possible, and when the leaves wither, the roots should be carefully lifted. This requires a good deal of attention, many of them being very small. They should be kept in a dry place till the ensuing month of February, and then planted one inch deep in fine soil.

Thus I have given a faithful account of the plan pursued by me in the raising of the seedling ranunculuses, however defective it may be. With regard to those sorts I sent, they are all seedlings of my own raising; some of them had been twice bloomed before this year; the greater part of those sent had bloomed last year but very weakly, from smallness of roots. Having gained a little more strength this year, they shewed to greater advantage.

Sorts of Seedling Ranunculuses sent to Edinburgh.

No.	COLOUR.	NAMES.
14.	White ground, mottled red,	{ Marshall Blucher ; raised from Shaw's fine Mottle.
16.	Do. do. purple-edged,	Lord Byron ; from do. do.
19.	Rose-coloured self,	{ Rose Magnificent ; from Loui- sette.
21.	White ground, spotted red,	Flora ; from do.
23.	Rose self,	Rose Unique ; from do.
33.	White ground, mottled red (faint),	{ Bragella ; from Duncan's Stripe or Hebe.
54.	Do. do. laced & spot- ted red,	{ Shakespeare ; from mixed seed.
57.	Cream ground, purple-edged,	Not yet named ; from do.
71.	White do. red spot,	Ullin ; from do.
101.	Do. do. dark red edged,	{ Sir W. Scott ; from Shaw's fine Mottle.
110.	Greyish-mottle,	Spencer ; from Louissette.
115.	Do. do.	{ Fuseli ; from Duncan's Stripe or Hebe.
123.	White ground, red spotted,	Addison ; from do. do.
130.	Do. do. purple do.	Tannahill : from do. do.
168.	Do. do. purple-edged,	Juno ; from mixed seed.
177.	Do. do. do. do.	Sir H. Raeburn ; from do.
214.	Do. do. red-mottled,	Not named ; from do.
121.	Do. do. do. do.	{ Not named ; from Duncan's Stripe or Hebe.
205.	Do. do. do. do.	Not named ; from do.
136.	Pure white self,	do. do. do.

I am, &c.

PAISLEY, }
29th Aug. 1826. }

XIV.

*Account of a Method of cultivating the Grape-
Vine.*

By Mr NINIAN NIVEN, Gardener at Belladrum, near
Inverness.

(Read 1st June 1826.)

THE more ordinary erections for the cultivation of the grape-vine are of such an expensive nature, that, in cases where economy is a consideration, and more particularly in those parts of Scotland where the expense of coal used in the forcing of grapes is material, the supply of this fruit must be either very limited, or it is entirely dispensed with. With a view to remedy this, I was induced to consider whether or not the vine might be cultivated on a different principle from that at present most generally practised in this country. With a view to this, in the winter of the year 1824, I reserved a few shoots of the prunings of a black *Constantia* vine, and, in the early spring of 1825, selected a few single eyes or buds from these shoots, planting them in a middle-sized pot, in a mixture of old vegetable mould and pit-sand, observing to cover with half an inch or so of pure sand, and

leaving the buds just visible on the surface, in the usual way of propagating from cuttings, and in this state allowing them to remain for two or three weeks in an airy temperate situation. I then had them removed to an early cucumber frame, and plunged in a moderate bottom heat. In a short time they began to grow, and, as soon as they were fairly rooted, I had them separated, and put into single pots, replunging them into a mild bottom heat, and keeping shifting as they advanced in growth, using little else than very old well-rotted stable-dung, with a small proportion of light soil. From this management, by the end of the season they produced shoots of well-ripened wood 24 feet in length; after which time (latter end of September) the plants were placed in an exposed situation, close to a south wall. I nailed up the shoots, to prevent them being blown about by the wind, and covered the pots, previous to the setting in of the winter, with a quantity of litter, so as to preserve the roots from the severe frosts. About November the shoots were cut back to about 10 feet from the pot. Standing over winter in this state, they were, in the ensuing spring, set into an early forcing-house, and some of them shewed not less than twenty-five bunches of grapes; but I reduced this quantity to one-half, so as to enable the plants the better to mature their load. The fruit set admirably, and ripened to a good size even in the plants in the pots, some of the bunches weighing a

pound and a half. With a view to cause the regular breaking of the buds, the shoot of each plant was trained to three stakes, so as to describe a circle, thus—

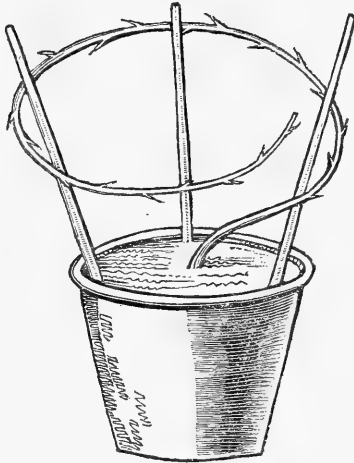

This at the same time rendered the plants more portable to any situation, as circumstances might require. One of the plants, turned out of the pot, and planted in a small fruiting pine-stove in the beginning of March, also shewed an equal quantity of fruit, and produced grapes of a very superior quality both as to size and flavour, being fit for the desert by the latter end of June.

Such being the result of these experiments, I am strongly induced to propose the following method

of fruiting the vine, for I consider the greatest difficulty overcome by the uniform success attending these trials.

What I propose, then, is simply this: To select a few shoots from the prunings of any vinery, where the wood has been well ripened, and from such sorts as are known to produce the best crops, and finest fruit, as the Black Hamburgh, Black Constantia, White Muscadine, White Sweetwater, St Peter's, or any such-like good bearers, as may suit the taste and experience of cultivators. The shoots should be cut into lengths, and stuck in by the heels in a sheltered situation, till about the month of February, when the buds should be selected, and put into a pot or pots, as already described. When once fairly set a-growing in a hot-bed, the growth may still be carried on in the spare room of any melon and cucumber frames at work. After the plants are separated, the shoots will soon extend. It should be observed, in their outset, that only one shoot is allowed to be produced, the buds being very apt to push double. It is proper to keep pinching off all superfluous appendages that will naturally occur.

As the young plants will now require to be trained in some situation where they may have a full run, I propose, as the best means of growing them to the extent required, to have a pit constructed for them. This pit should be laid out in two divisions, the one to be used for nursing, and the other for

fruiting, as in the management of pine-apples, only having conductors of wood, in the form of a trellis, in the inside, at the distance of a foot or so from the glass, for training the shoots to, as they advance all along the length of the pit. These may be so constructed as to be lifted out altogether, as occasion may require. The plants should be placed at each end of the pit, and trained to pass each other in the middle, thus training two shoots upon each conductor, from east to west, the one stopping where the other starts. I consider that eight plants at each end, in a pit of the dimensions noted on the annexed plan (Plate V.), will be sufficient; that is, sixteen plants in all. These may be expected to produce at least 300 bunches of grapes. But to return:— By the time the young plants are beginning to require more room than the melon or cucumber frames will allow, it being understood that they have been shifted once or twice after the first potting, they must, previous to being set into the nursing-pit, be shifted for good and all, into the largest-sized pots (say twelve inches diameter), which will be found perfectly sufficient to produce shoots of twenty or more feet in length, and proportionably strong, observing to pot, as already hinted, with well-rotted old dung, and a little fresh light soil, of a rich quality. This is all the management they will now require, excepting judicious attention in airing, pruning, &c. and especially the giving regular and liberal supplies of water, both at root and over head.

The nursing-pit may be wrought altogether with tree leaves collected in autumn ; preferring those of the most hard and durable nature, as those of the oak, beech, &c. ; the pit being filled with leaves to within three feet or so of the sashes, and firmly packed. Two or three square boxes, without bottoms, made of a single deal cut into four, so as to give, when nailed together, an enclosed space of about four feet square, will, by being placed on the surface of the leaves, in the middle of the pit, and filled with mould, produce an excellent crop of melons. The one will not in the least interfere with the other ; for, by the time the vines are meeting, the crop of melons will be nearly ripe, and the partial shade will benefit them. Thus, this little compartment may be made to answer two important ends, of the practicability of which I am fully satisfied, having had occasion to adopt the above plan in the growing of melons last year, and with the most satisfactory results.

Regarding the Fruiting Pit, I would advise by all means its having the advantage of a flue, so as to ripen the crop at an early season, if required, and also for the preservation of the fruit in damp weather. The plants having been well grown, and the wood properly ripened, and exposed to the winter, as already observed, about the middle of February let the fruiting-pit be filled with leaves, as directed for the nursing one, and allowed to exhaust its first heat, before putting in the plants, which may be about

the latter end of the month. The plants should be turned out of their pots, and plunged, or more properly planted, at each end among the leaves, observing to have a quantity of half-decayed ones, of a close texture, all round the balls, treading all very firmly round about: this being done, and the shoots trained to their respective conductors, they are ready for forcing.

If the weather be favourable and mild, very little fire-heat will be required for some time, as the heat arising from the leaves will be sufficient, with covering up at night, until the buds begin to break. Previous to this time, air should be admitted freely, let the weather be what it may, so as to ensure their regular breaking,—a point of great importance in all cases of early forcing. Whenever they indicate a general breaking, a moderate fire must be applied, and gradually increased to the proper temperature for the plant (from 65° to 75° Fahrenheit), till the advancing season shall render it unnecessary. At most, a few weeks of firing will, in ordinary seasons, be sufficient, and that at a very moderate expence, in comparison to that required in the heating of the common vinery, which, in any part of the kingdom where coals are expensive, is a material consideration. Supposing the forcing to have begun as above, the crop will be ready by the end of May, or beginning of June, if properly followed up.

The same plants, if well managed, may be so trained as to produce a superior crop of fruit the se-

cond year ; but I would advise a renewal of the plants every third season, the better to ensure a succession of crops, as the nourishment from the leaves will by this time be nearly exhausted, and require renewal. Fruit produced in this way would, I am confident, from what I have proved, be of a very superior quality to those of the common vinery. Without a trial, no one can form any just idea how well the vine repays these attentions. The plant being young, both in root and stem, partakes of the purest health, and in such a state must naturally produce the best of fruit. Those unacquainted with the nature of the vine, when told that a single bud may, with the greatest ease, be grown from twenty to thirty feet in one season, may, I am aware, be startled, and ready to question the truth of such an assertion ; but by every practical man who knows the nature of the plant, the thing will be at once admitted. In the outset of these experiments, I was far from anticipating the success of their results ; and it is only from these that I am thus led to propose the present method, being perfectly satisfied that whoever adopts it will be fully repaid.

The expence attending a middle-sized vinery is considerable ; and not only that, but from the planting of the vines to the reaping of a crop, in many cases a considerable time elapses. I have, for my own part, seen vineries where not a single bunch of grapes was cut for three and even four years after planting. But supposing it only two years, at the

best, partial crops only can be expected for some succeeding years. Added to this, the expence of erecting and of upholding, besides the frequent failures in the common vineries, are considerations of such importance, as to make any improvement in the method of fruiting the vine very desirable.

The expence of an ordinary-sized vinehouse will be, upon the least calculation, £100, besides having to wait so long before a fair crop can be expected; whereas a complete erection on the proposed system, that will give an equal supply of fruit, and which would come into full bearing the very first season, may (at least in Inverness-shire) be finished for about £50, making the original cost only one-half, besides a very diminished expence in upholding.

In this way, also, the sorts of grape may be altered at pleasure, without interfering in the least with the expectation of a crop; for the principal management depends on the growing of the young plants, and which, with attention, will be found perfectly easy; so that, unless some untoward circumstance takes place in the management, a full crop may be always depended on. Moreover, the pits being out of employment in winter, will be found very useful for the accommodation of a few choice tender exotics,—a service also not the least desirable, when the taste of any lady or gentleman may incline that way. It may not be improper still to add, that, in the forcing of common grape-houses, the extensive, and I may even say unnecessary

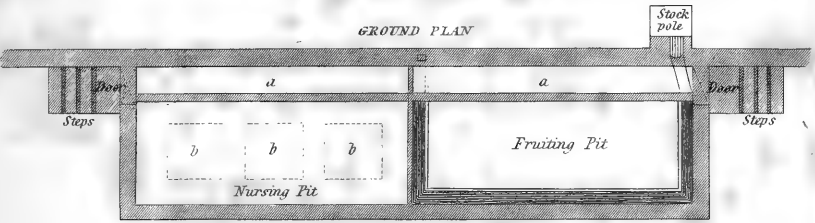

PLATE V.

Hort. Soc. Mem. Vol. IV. p. 2.

VINE PITS

GROUND PLAN



SECTION

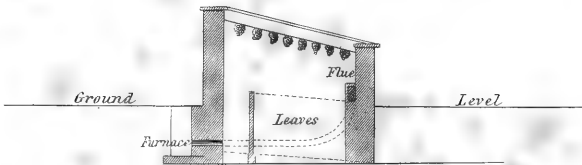

ELEVATION

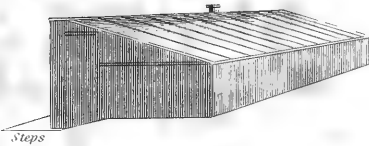

CONDUCTORS

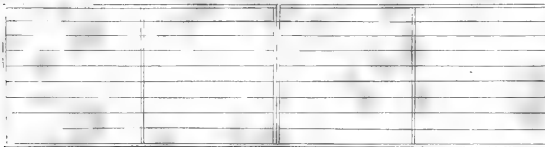

SCALE

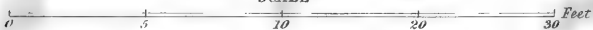

space, that requires to be heated, causes a great consumpt of fuel; while the expence of fuel by the present method, will not exceed one-tenth part of what would be necessary under the old system.

Before leaving the subject, I would also observe, that, in the growing of the vine, a moist heat is known to be of great importance throughout the most of the season: this it will enjoy, to a considerable extent, in the method just proposed, from the length of time a well made up pit of leaves is capable of retaining its heat. I have known leaves keep such a heat for a whole twelvemonth, without being disturbed.



Explanation of Plate V.

a, a, On ground-plan, shews a passage along the back of the pit.

b, b, b, Shews the position of melon boxes in the nursing-pit.

The other parts of the Plate require no explanation.

Note.—In the case of fruiting vines on plants for two years, the Nursing-pit will be sufficient to supply plants for two Fruiting pits.

XV.

On Mulching and Watering Fruit-tree Borders.

In a Letter from Mr JAMES SMITH, Gardener at
Hopetoun House, to the Secretary.

(Read 1st March 1827.)

SIR,

IN compliance with your request, I send you an account of the method of *mulching* and *watering* the borders next the fruit-walls which is practised here. But, before doing so, allow me to make a few general observations.

It is obviously a more difficult thing to obtain a supply of full-sized and well ripened wall-fruit, than the greatest abundance of orchard produce. The cultivator, therefore, if he would be successful, must submit to considerable labour and attention. In addition to what I am about to describe, it is necessary that the borders be well prepared, and composed of soil which is the best that can be procured, and well adapted to the various kinds of fruit-trees. In selecting and preparing the soil, attention must be paid to the situation of the walls, since it is evidently expedient that borders having a considerable

declivity, should be of a more retentive nature than those in low and flat situations.

Further, it is to be remarked, that, even when the borders are of an excellent quality, large and frequent crops of culinary vegetables are extremely injurious to the adjoining wall-trees, which derive the whole of their nourishment from the border in front. Tempted as gardeners are by the facility of here raising early crops of pease, beans, &c. it is perhaps too much to expect that they will entirely forego the practice. But if they have any regard for fruit, they will be moderate, cropping only once a-year, and keeping the vegetables at some distance from the wall.

Lastly, dry seasons have a powerful effect in preventing the swelling of the finer fruits, particularly in sloping situations, and on light or gravelly soils. This has been experienced for several years past, and especially in this last season (1826). At several places, where no remedy was applied, the drought proved so severe, that the finer fruits were much inferior in point of size. Many were gritty, and almost all ripened prematurely, and did not keep.

Having premised these remarks, I shall now detail my method of *mulching* and watering fruit-trees, proceeding in the order in which the operations occur.

As soon as the trees have been pruned and nailed, or have got what is called their winter-dressing,

the borders are carefully digged over, and laid up in rather a rough state, to retain the moisture which falls at that season. To prevent any treading on the borders, a line of deals or thin planks, about seven or eight inches broad, is laid along the bottom of the wall, for occasionally walking on. As the season advances, and the borders become dry, the mulching takes place. Well rotted hot-bed dung, reserved in winter for this purpose, is laid on the border, beginning at the base of the wall, and extending outward about eight feet. The dung is never laid on less than three or four inches thick, and slopes off in front, that it may not have an unsightly appearance by terminating abruptly. Only one plank is removed at a time, the rest being reserved for wheeling upon, that the ground may be kept soft and unbroken. After the mulching is finished, and the dung properly levelled, the planks are replaced at a suitable distance from the wall, by way of a footpath.

My reasons for preferring the best hot-bed dung are, that all seeds being destroyed by previous fermentation, it remains longer free from weeds, and that it is not so apt to be blown about by high winds as fresh litter. Besides being subjected to the influence of the sun, and frequent watering, it is converted into a substance somewhat resembling peat-moss, of by no means a disagreeable appearance. The mulching is suffered to remain till the dry weather is past, when it is removed, and the surface of the ground is hoed and raked smooth, to reflect the

rays of the sun, and to promote the maturity of the fruit, and the ripening of the flower-buds of the following season.

The principal use of mulching is the prevention or diminution of evaporation. The moisture upon which fruit-trees in dry years subsist, is solely the produce of the winter and spring rain, as must be known to every one who has observed to how small a depth the summer showers penetrate exposed and hardened soils. The case is even worse where there are crops of vegetables, as they extract the sap which is in the ground, and disperse the slight rains before they reach the earth. I have seen a fruit-border so exhausted and parched, by a crop of early peas or cauliflower, as to be scarcely capable of supporting any thing before the damps of autumn had restored it to somewhat of its proper tone. It is evident, that whatever prevents an excessive escape of moisture by evaporation, must prove very beneficial.

In the course of the summer, the borders are frequently watered over the dung. This is generally done pretty freely, and in very dry seasons large quantities are applied. From what I have already said, this will perhaps be thought superfluous, as it may seem that the water will not subside far into the soil. But this is not the case, for the soil below the dung is soft, and comparatively damp, and therefore does not resist the fluid. But even upon the supposition that the water does not sink far in-

to the ground, the practice must be beneficial, since, by this means, the evaporation is confined in a great measure to the surface of the dung, whereas were the dung to become dry, it must arise from the soil below.

My belief of the utility of mulching and watering does not rest on theoretical considerations merely; it has been amply confirmed by the experience of the last season (1826). In many gardens apricots were very diminutive; here we had an uncommonly abundant crop, and, notwithstanding the drought, the single fruit were perhaps one-third larger than those for which I obtained the Society's medal in 1825. I found the same treatment equally beneficial when applied to the finer pears, such as Brown Beurré, Gansel's bergamotte, Crasanne, &c.

I am fully satisfied, that the *mildew* on peach-trees may be prevented, or in a great measure kept under, by seasonable and copious waterings in the months of July and August. It is stated by Mr Harrison, that this disease is induced by the roots being in a dry condition, and the juices consequently stagnant, while the air is charged with moisture. My own experience completely coincides with that of this ingenious horticulturist. I have no doubt that, whatever be the original cause of mildew*, that its ravages are greatly accelerated

* It is to be regretted that none of our able cryptogamists have given a popular account of the natural history of mildew.

by the circumstances mentioned. I do not mean to be understood to say, that waterings, however copious, will remove the disease when fairly established, but unquestionably they are an excellent preventive. The best method of applying water to the roots of peach as well as other fruit-trees, is over dung, since the mulching prevents the water from battering the soil, and running off during the operation.

The practice of mulching and watering may appear expensive and laborious, but it is amply compensated by the improvement of the fruit. Watering is doubtless laborious in those gardens which are not properly furnished with water-pipes. Being

If there is one, it is not accessible to gardeners. It is not generally known that mildew is a minute parasitical fungous plant, and hence we sometimes hear useless, and even absurd, remedies proposed for its cure.

Note by the Editors.—Dr Greville, in his *Flora Edinensis*, p. 464., under *Sporotrichum macrosporum*, has given as stations for that minute plant, “Apple-trees, the hawthorn, peach-trees, &c. very common in spring and the beginning of summer;” and he has added, “To gardeners it is well known as a kind of mildew, or blight, and is commonly taken for an insect. The leaves of the peach-trees, even when protected by glass, are often attacked by it, nor does the fruit itself always escape, in which case it frequently drops off. The leaves are more or less distorted by it. As its production is probably the result of a peculiar state of the atmosphere, there is little chance of any means being discovered for its prevention.”

fortunate at Hopetoun-House Garden in this respect, I find it an easy matter; indeed a single boy frequently performs the operation. As the water is poured upon the mulching, it can be done at any period of the day, when it is not required for any other purpose.

HOPETOUN-HOUSE, }
15th Dec. 1826. }

XVI.

*Notice of some Forest and Ornamental Trees
which deserve the attention of Scottish cultiva-
tors.*

In a Letter from GILBERT LAING MEASON, Esq. to the
Secretary.

(Read 6th September 1821.)

DEAR SIR,

WHEN I was in Paris in 1816, I had frequent conversations with Mr André Michaux, author of the excellent work on American trees. From trials made in France of different trees and shrubs, he recommended several to the attention of gentlemen in Scotland. I shall note to you some of these.

Betula papyracea. Paper Birch-tree.—This is the true Canadian Canoe Birch. The growth of this tree has been rapid near Paris, and the wood proves to be of excellent quality. It is also highly ornamental. It has not yet been known to get to a large size in Scotland, but it should be more fully tried.

Fraxinus Americana. White American Ash.—This is a very valuable tree. It grows freely, very tall and upright, and is quicker in growth than

the common ash. I measured some years ago a plank of white ash in a cabinet-maker's warehouse in Edinburgh, that was $3\frac{1}{2}$ feet broad and 27 feet long, and without a knot. It seldom, however, attains a large size in Scotland; and the young wood is apt to be injured in our winters. It ought to be more cultivated in warm and sheltered situations.

Pinus Laricio. Pin du Corse, or Corsican Pine.—The first time I became acquainted with this tree, was on being shewn a very beautiful one in the Garden of Plants at Paris. It was first brought from Corsica; but Monsieur Picot de la Peyrouse of Toulouse assured me, that he has found the same species in the Pyrenees. It is a very handsome tree, assuming more the habit of a deciduous forest tree, than of the pine or fir class. The wood is said to be good, and the growth is quick*. The young plants being somewhat tender, this species has been less attended to in Scotland than it should be.

Ilex Chinensis. Houx de la Chine, or Chinese Holly.—This is a quick growing evergreen, that appears suited for division-hedges in a flower-garden. The leaves are small, and without spines. I saw annual shoots of this tree 18 inches long, in the King's nursery at Paris. In Scotland, it would require the most sheltered situations, being here still regarded as a greenhouse plant.

* A description of this species will be found in the Appendix to the Horticultural Tour, &c. p. 552.

Orme de Sibere, or Siberian Elm.—This is an excellent fast growing tree, possessing the quality of toughness in a degree superior perhaps to any other tree in Europe; at least, from repeated trials, it has been found in France to be one of the toughest and most elastic of woods. I have planted a few specimens, which thrive vigorously in a strong soil in Forfarshire. The tree grows to a considerable size, and is quite distinct from the *Ulmus pumila*, which is often called Siberian Elm in our nurseries.

Bourgene de Canadie?—An evergreen that has proved itself in France to form an excellent hedge.

Juglans alba Americana, or White Walnut.—A fine tree, of much quicker growth than the Common Walnut. It has become in thirty years a large tree in the north of France. In Scotland, the young wood is apt to be injured during winter; and the tree will succeed only in sheltered situations.

Tilleul argenté de Constantinople. Turkish Lime.—A very fine tree; when in flower it gives out a most delightful smell. This is probably the *Tilia argentea* of Waldstein and Kitaibel.

I am, &c.

LINDERTIS, }
28th July 1821. }

XVII.

Notice of the hardy Fruits of Upper Canada.

By Mr THOMAS BLAIR.

(Read 1st March 1827.)

DURING my residence in Upper Canada, I had frequent opportunities of seeing and admiring the profusion of fine fruit produced in that country: the apples in the orchards are particularly fine.

Accustomed as I had been to see fruit-trees in general raised only from grafts or buds, I had no idea of the facility with which apple trees can be raised from seed, and in a very few years, in that fine climate, produce abundance of excellent flavoured fruit. There are many of the trees, however, that produce fruit fit only for cider, which are more valuable to the inhabitants than the finer sorts, as they can find a ready sale for their cider, which they could not do for the apples, were they ever so fine flavoured; and, for that reason, they are at no trouble in selecting their seed from the finest kinds, or grafting or budding from them.

The inhabitants of Lower Canada seem to have paid considerable attention to the cultivation of

fruit-trees for a length of time, as may be judged from the fine specimens of healthy old trees that are to be seen in their orchards. They cultivate several kinds of very fine apples, which have probably been introduced from France, particularly the *Pomme-grise*, *Bourassa*, and *Fameuse*: they are also beginning to cultivate several kinds that have been raised from seed in the country, but, from the appearance and flavour of most of them, there seems to have been but little care taken in selecting of the seeds from the fine old kinds. In my opinion, they ought to use every diligence in raising seedlings from them, as I have little doubt but they will soon begin to degenerate, like many of the fine old kinds in Scotland and England; and I have no doubt whatever, that, if proper care is taken in saving of the seeds, seedlings will be procured, so similar to the original in appearance and flavour, that the difference would not be easily detected.

I was informed that the island of Montreal, about thirty years ago, was much famed for the quantity and excellent quality of its pears, but now there are very few of that fine fruit in the country: the old trees are fast disappearing, and the greater part of the young ones are in an unhealthy state; and no person could assign any cause for this general decay of their pear trees.

Apple trees I have frequently seen in an unhealthy state, both in Upper Canada and the United States, where they had been planted on land that

had been several years cleared or in cultivation ; whereas, on the contrary, when they are planted on ground newly cleared, and amongst the stumps and roots of forest trees, there they never refuse to grow, and that most luxuriantly, so that in a few years they become large trees much sooner than they would in the same space of time in Scotland : for that reason, most of the settlers that emigrate from Scotland to that country, are led into an error ; they generally commence raising apple trees from seed, and defer planting an orchard until the stumps and roots of the forest trees are nearly all decayed, and the land frequently ploughed ; whereas much time could be saved by planting the trees as soon as the land is cleared ; and trees can be purchased at a moderate expence from small nurseries, which are now pretty general in the country.

The Kentish cherry succeeds better than any other that I have seen cultivated in any part of North America that I have visited : they produce fruit in great abundance, and certainly better flavoured than in this country. They are propagated chiefly from suckers, which leads me to suppose that the original trees have been propagated from seeds imported from Europe. I have seen good crops of some other kinds in Kentucky and Virginia, viz. Blackhearts, Maydukes, &c. ; but there the trees are generally much injured by the intense heat of the sun : they are always grown as standards, with tall stems, and most kinds of cherry-trees grow very

erect ; from which circumstance, the foliage can yield no protection or shade to the stem or trunk of the tree ; they soon begin to gum on the side next the sun, and in a few years it will be completely decayed, except a small piece of wood and bark on the north side. This, however, could be easily remedied, by shading the stem from the sun with boards or otherwise ; for I observed that the branches which were shaded from the sun by their own foliage, had sustained no injury from the above cause.

Peach-trees succeed tolerably well in Lower Canada on walls, with a little protection from mats in winter. In Upper Canada, particularly on the Niagara River, they succeed very well as standards. They grow with great rapidity, but very little attention is paid to them : they are all raised from seed, and many will produce blossoms, if not fruit, the third summer. A few are large and fine flavoured fruit, and many tolerable.

Quinces, on the Niagara River, produce generally a good crop. They are certainly a finer flavoured fruit than those produced in England, being free from the disagreeable smell that the English quinces have, and are esteemed the best fruit for preserving in that country. The trees are remarkably dwarf, which I suspect is owing to the method they have in propagating them, which is altogether from cuttings, and these are generally branches of considerable size, and planted in the spring.

XVIII.

Hints on Increasing the Warmth of Garden-Walls, by painting them Black; with a Description of an improved mode of constructing Subdivision Walls in Gardens, &c.

By Mr JOHN HENDERSON, Den Nursery, Brechin*.

(Read 1st June 1826.)

Painting Walls black.—IT has long been known, that the ripening of wall-fruit may be assisted, by colouring the wall with *black paint*; but as few gardeners have yet availed themselves of this advantage, it may not be uninteresting to the Society to lay before them what has fallen under my own observation on this subject, together with the result

* The Horticultural Society of London having placed at the disposal of the Caledonian Horticultural Society one of their large Silver Medals yearly, "to be awarded to any person who, by his exhibitions, cultivation, or communications on horticultural subjects, shall appear to the Council of said Caledonian Horticultural Society to be most deserving of such testimony of merit within the year," the London Medal for 1826 was voted to Mr Henderson for this communication.—
P. N. SEC.

of several experiments which I have lately made in a similar department of horticulture.

The first black painted walls I ever saw, were in the gardens of the late Mr Shand of Arnhall, at The Burn. The scheme having been suggested to this gentleman, who was a zealous promoter of all kinds of rural improvements, he painted, with oil-paint, several patches of the walls of his gardens, on the different aspects, as a trial; and one of these examples deserves to be particularly mentioned. In order more effectually to ascertain the merits of the painted walls, the wall was painted only behind *the one-half of an apple tree*, while the wall behind the other half was left in its ordinary condition. The effect was very striking. The leaves of that part of the tree against the unpainted wall were (like those of the other trees of the garden where the walls had not been painted) much destroyed by caterpillars in spring, and covered with red spiders during summer; while the leaves on the other half of the tree were of a fine glossy green, and undisturbed by insects of any kind; and besides, the fruit on the half of the tree opposite to the painted wall, was more abundant, of a larger size, and better ripened than that produced on the other half*. The suc-

* Much of the benefit in this case may have depended on the painting of the wall with oil-paint having destroyed the insects, their ova and larvæ, lodged about the wall: the branches, foliage, and flower-buds, having thus been rendered

cess of these experiments being so flattering, the proprietor was induced to try the scheme on a larger scale; and accordingly, next year, a wall, several hundred feet in length, was blackened, and the result answered his expectations. I had an opportunity of witnessing these operations going on, and, from their very extraordinary effects, not only in improving the quality, and increasing the quantity of fruit, but also in contributing materially to the health and vigour of the trees, I was persuaded to make trial of the plan myself.

Use of Coal-tar.—But as I considered oil-paint as rather too expensive for a rough stone wall, I made use of coal-tar instead of it, which can be got for a mere trifle at any coal gas-work, and which is fully as offensive to insects as oil-paint. My method of executing the work was this:—The *tar* was boiled over a stove placed near the spot, for the purpose of keeping it hot, while it was laid upon the wall with a coarse hair-brush. The trees being previously loosened from the wall, were, during the operation, fastened to a number of stakes placed in the border, and covered with mats, to prevent any particles of the boiling liquid approaching them. After the second coating was dry, as coal-tar is not

healthy and clean, the fruit would naturally partake of the advantage. It is not easy, therefore, to estimate to what extent *colour* here exerted influence.—SEC.

of itself a *jet-black*, I added a coating of linseed-oil, which gave the wall a fine shining blackness. This may seem as expensive as using oil-paint at once, but it will be found far otherwise; for the tar having in a manner smoothed the surface of the wall, comparatively little oil is necessary. I may add, that the painting of my wall with coal-tar has fully realized my expectations. The smell is at first offensive; but this soon went off.

Some may think that black walls would have a disagreeable appearance; and, indeed, if the walls of a house were painted black, it must be allowed they would look rather gloomy; but it is quite different with the walls of a garden. However, they may at pleasure be tastefully relieved by white draughts, in the form of an ashlar building, which would give them something of the appearance of black marble.

Improvement of old Garden-walls.—There are a great many old garden-walls which have been built with clay in the heart, or perhaps without any mortar at all, excepting a little lime on the outsides, and which of course require very large nails, and in some places even plugs of wood to fasten the nails into. Such walls, I am aware, would not answer well for being blackened, as the continual tearing out of the lime would soon render them very ugly. They are certainly very unsuitable for any purpose,—no tree can be well trained upon them,—

they are very apt to be overgrown with moss and lichens,—and, above all, they harbour great swarms of insects, forming, as they do, commodious depositories for the eggs of the fruit-tree caterpillars, and the red spider: They have, therefore, it would appear, great need to be either thoroughly repaired or renewed. The former expedient, however, is seldom deemed practicable, and the latter is not at all times convenient.

This seemingly great evil may nevertheless be remedied at a moderate expence (not the least important consideration), by merely plastering over the walls with common plaster, and then attaching to the same a wire trellis, to which in future the trees are to be trained. This is by no means a costly expedient, and on an old wall, I lately had the operation performed as follows:—Before the plaster was put on, a number of nails were driven into the wall, about three feet apart, in horizontal lines, which lines were about nine inches asunder. After the plaster was dry, a wire of a proper thickness was fastened to the first nail, and from it drawn very tightly, and twisted round the second, and so on with all the rest. The nails were then driven home, and the trellis was perfectly firm. The plaster may be mixed with smithy ashes, instead of sand, which I think renders it more durable, as I find, that, when prepared in this way, it is not so liable to be injured by frost. Such walls may be blackened in the way I have already described. It may be difficult to

preserve the plaster on walls that are damp; and many walls are so from the coping being too thin, and on that account loosened by the frost in winter. In such cases, an additional ridge of stones should be put on the top, and glazed over with Roman cement; or the joints of the coping may be filled with the same substance.

Speaking of the coping of walls, I may also add, that it does not seem necessary that they should project more than an inch or two; and any shelter which the tree might require when in blossom (since it is only then that such protection can be serviceable), may be supplied by moveable boards, erected only at this season, and which boards may last for many years.

Subdivision Walls in Gardens.—I farther take the liberty to solicit the Society's notice of a cheap and advantageous method of forming subdivision walls in gardens, which has lately occurred to me, and which, from an erection I have made to prove my theory, I am convinced will considerably facilitate the ripening of fine fruits.

These walls are constructed of *lath* and *plaster*, and stand at an angle of 55° from the horizon, sloping to the sun like the roof of a house.

The circumstance that first suggested to me the idea that inclined walls are more susceptible of heat than perpendicular ones, was the following:—In front of an old hedge, which extended for a hundred

yards along the head of a steep bank, looking to the south, I removed the earth to the depth of 9 or 10 feet, thus forming a sloping earthen wall of the same height. This was always, I observed, much hotter than a stone-wall, which was doubtless to be attributed in some measure to the blackness of the earth, as well as to the position itself. Upon this wall I was in the custom of training fruit-trees; and though they were placed there only for the purpose of training, and of course never allowed to remain longer than three years at most, I had tolerable crops of cherries, which ripened always ten days earlier than against a perpendicular wall of the same aspect; and any fruit produced by apple-trees during their short continuance on this wall, were of large size, and particularly well coloured and ripened. This, together with the fact, that, whenever the sun's rays fall perpendicularly, there is always the strongest heat, as is the case in all tropical countries, and on the front of steep hills, even under less favourable latitudes, induced me to think that inclined walls might be used with great advantage in gardens*.

The wall which I have erected fronts nearly south, and inclines, as I have already mentioned, at an

* The author is evidently not aware of the fact of inclined walls having been proposed about a hundred years ago by M. De Douilliers, but writes from his own observation and practice.—SEC.

angle of 55° , which seems to be about the proper angle for the aspect, (as doubtless the angle of such walls must be regulated according to their aspect). It is nine feet high, measuring the slope, and was constructed thus:—I got a number of rafters or joists made in the form of the adjoining figure,

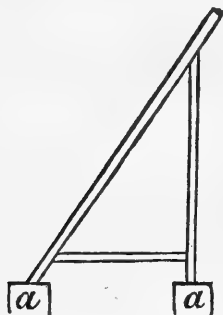

and of the proper angle; and having sunk two rows of stones in the ground, at regular distances, I placed the feet of the rafters *aa* upon these stones, and fastened them to the same with iron-bats. I then covered the face of the rafters with lath, and gave it two coats of plaster, to which, when dry, I added two coats of coal-tar, and one of linseed-oil. As the last step, a wire-trellis was attached to it, for the training of the trees. Last spring some peaches and nectarines were planted against this wall, which have made very fine shoots, while the wood is excellently well ripened.

The heat of the inclined wall surprises every one who examines it. When the heat of a stone-

wall of the same aspect was 65° Fahrenheit, this was above 90° . In fact, it is so hot often, that it would almost burn the hand; while, at the same time, the trees are not in the least injured by this high degree of heat, which may be accounted for by the constant *shifting* of the heated air. In a warm sunny day, one may observe the hot air rising in beautiful undulations to the top of the wall. It will, however, be necessary, while the trees are in blossom, to shelter a wall of this kind with thin canvas, which may remain upon it day and night till the fruit is set; for it is probable that the position of this wall may be as cold at night as that of a standard tree. But this can never detract from its claims, since we are aware that it is not so much the *shelter* of a wall, as the reflection of the sun's rays upon it, which brings fruit to perfection.

These walls might be erected in gardens in many different ways. They would look very well in front of a hedge, and the space underneath might be used as a mushroom-house, a tool-shed, or a storehouse for culinary roots during winter. Banks of earth might even be thrown up, and after being paved with stone, and plastered, might be used as inclined walls. Steep terrace-banks might also answer the same purpose.

Training of Fruit-trees.—The training and pruning of fruit-trees, would be a very proper appendage to this communication, were it not too wide

a field to enter upon, after having trespassed so freely upon the Society's patience. But I would beg leave to say a few words upon one particular branch of the subject, from its being intimately connected with what I have already advanced.

My great object is to *improve* the climate for fruit-trees; and as this must be confessed to be a point of much importance, so it will be also admitted that we ought to be careful of spending unprofitably the heat we are already in possession of. By the mode of training too generally in use at present, however, the improvidence in this respect is very conspicuous.

By a constant cutting off of *breast-wood*, especially in pear trees and the fine apples, and of course a continual provoking of the tree to push out more, the spurs become soon of an enormous length, and consequently the fruit they produce must hang at a considerable distance from the wall. Now, it can be proved, by applying a thermometer, that, at the distance of several inches from the wall, the air is no hotter than the general air of the garden; and hence the evil of which I complain. It is not, indeed, uncommon to see the spurs of an old tree standing out like the teeth of a rake, or the bristled face of a cut hedge. Nor is it to be wondered at, that the fruit of such trees should be always small, and never well-flavoured.

Importance of nailing Spurs close to the Wall.

—I have now to state, that, by the simple expedient

of nailing the spurs *close* to the walls, the finest fruit imaginable may be procured. To dress old trees in this manner, it will be necessary to take out every alternate branch, and then to twist round the whole length of the remaining ones, by beginning at the point of the branch, and nailing every spur close to the wall; and, if possible, they should be *turned down*, that position being also thought, on good grounds, to stimulate the trees to fruitfulness. A gentleman in my neighbourhood had two Nonpareil apple trees in this state. They had been trained horizontally, and the branches laid in about seven inches apart; the spurs were about nine inches in length, and quite healthy. Agreeably to my suggestion, they were treated as above; and the fruit was worth more (the gentleman informed me) the first year after the operation, than all that had ever grown on them before. It is now seven years since this was done, and they still continue very fruitful. A gardener in this quarter tried the same method of training two or three years ago. He afterwards brought me a sample of pears which had grown on the branches so managed, together with a few of those produced on the spurs standing out in their natural condition, and the superiority of the former over the latter, in size and flavour, was quite surprising. The kinds of pear trees were Auchans, St Germain's, and Brown Beurré; and the wall against which they were trained, was built of dark-coloured whinstone.

From all this, I am confirmed in my opinion, that it is owing neither to age, nor deficiency of soil, that many trees bear such small trifling fruit, but to an injudicious mode of training and pruning; and, instead of complaining that the spurs of a tree are too old, I would consider it rather an advantage to have old spurs; since the fruit of old trees, and of old wood, is sooner ripe, and much higher flavoured, than that of young ones,—provided always that it can be made to grow equally near the walls.

In order to prevent young trees from running into a number of rough unmanageable spurs, the leading branches should never be laid in closer than from *one* to *two* feet apart, and then the intermediate spaces may be filled with bearing spurs, which, I once more repeat, ought to be always closely nailed to the wall.

DEN NURSERY, BRECHIN, }
5th January 1826. }

P. S. Since writing the above, I have now to add the result of another year's experience, that of 1826, during the progress of which I have found no occasion to retract what has been advanced in the preceding pages. I have had a crop of very fine *Noblesse* Peaches this season, on a perpendicular black-painted wall. They ripened very early, and were far superior in flavour to any I ever saw under glass.

This might be partly owing to the uncommon warmth of the season, although there is no doubt that the blackening of the wall assisted greatly; since, in this part of the country, it is only in favourable seasons that even the Red Magdalenes can be brought to any perfection on open walls. But as it is only in opposition to plain stone-walls that the beneficial effects of painting can be properly exhibited, I may here mention, that, whenever I have made investigations upon the subject, there has always been a marked difference in favour of painted walls.

I find that oil-paint and coal-tar answer equally well for painting walls. Both seem to have the same effect in clearing the trees of insects; but whether this particular advantage will be permanent, or only for a few seasons after painting, time only can determine. In the course of my experiments, I have tried both oil-paint and coal-tar: the latter is indeed the cheaper in the first purchase; but its preparation is attended with a good deal of trouble, as it requires excessive boiling before all the aqueous particles can be separated from it, and till then it would not answer the purpose.

As to the sloping wall alluded to in the foregoing paper, I would beg leave to add, that I have continued to observe the extraordinary effect of the sun's rays upon it, and to contrast its heat with that of a perpendicular wall. The difference is generally about 20 degrees. The peach-trees which I planted

against this wall, have ripened their shoots fully as well as I ever saw in a peach-house, and are covered with blossom-buds. A black Hamburgh grape-vine planted here in June 1825, has also made very fine wood, and, with the assistance of some shelter in the early part of the season, it will, I expect, bring its fruit to maturity.

I may farther state, that I had a standard Hawthorndean apple growing on a pretty steep bank, on which I formed a sloping wall, by paving with stones between the stem of the tree and the foot of the bank. To this wall I bent down and fastened the tree. The operation has improved both the size and colour of the fruit to an astonishing degree. And indeed every thing in the way of analogy seems to favour the idea of sloping walls. Every one who has made the experiment, is aware of the superiority of the fruit produced by trees trained on the roofs of houses, to that which grows on the front walls, even though all on the same tree; and I have observed that, though not so soon in blossom, the fruit is generally ripe about a week earlier.

It ought to be borne in mind, that, if such walls are erected of lath and plaster, the former should be much thicker than that generally used, so that it may not start by the intense heat; and the latter should be put on early in the season, in order that it may be perfectly dry before the frost sets in, which would otherwise spoil it completely; but, to

obviate the risk of either of these contingencies, they could, at a comparatively trifling expence, be constructed entirely of wood, which would answer the purpose equally well.

January 1827.

XIX.

*On the raising of Mushrooms, and on the forcing
of Rhubarb Stalks in the open air*.*

In a Letter from Mr JAMES STUART, Gardener to Sir JOHN HOPE, Baronet, at Pinkie House, Musselburgh, to the Secretary.

(Read 6th July 1826.)

DEAR SIR,

YOUR favour was duly received, and I return you many thanks for your kind attention in preserving the clusters of mushrooms for the inspection of the committee. In compliance with their request communicated by you, I shall give an account of my mode of raising mushrooms, and of forcing rhubarb ; although I feel myself, unable to do these subjects

* On 15th June 1826, the Society's Silver Medal was awarded to Mr Stuart, for introducing the forcing and blanching of rhubarb stalks in the open ground, in the manner of sea-cale ; and for some remarkable clusters of cultivated mushrooms exhibited to the meeting.

the justice that is necessary to make them fully understood.

I generally form the base of the mushroom beds with rubbish of brickbats, lime, or ashes, to preserve the beds from damp. The bottom is made to slope from the wall; being raised six inches high at the wall. The bed is made three feet broad, and the length is regulated at pleasure. Then, having procured a quantity of dung from a shed where cattle or horses have been kept for five or six months, preferring the dung that is dried moderately, I lay it five inches thick next the wall, and slope it off to one inch thick in front. Allow it to settle for eight days or so. If any thing like overheating or firing appears, open up the bed, and let the heat go off. When the heat becomes moderate, lay the bed over, three or four inches thick, with fresh horse-droppings. Then tread it regularly over, and beat it well with the back of a spade. Then bore holes quite throughout to the rubbish, four inches in diameter, and at twelve inches apart; and when all danger of burning is over, fill these holes half up with fresh droppings a little dried. Then spawn the bed with spawn from a dunghil, shed, or mill track. The spawn is placed in the middle of the hole, covering up the spawn with dry droppings. Spawn from old mushroom beds ought never to be used, because spawn ought always to be in a fresh vigorous state. Earth the bed immediately, if no danger of overheating is apprehended; or earth it when the heat is mo-

derate, three inches deep. I prefer light rotten *wrackie* earth *, mixed with one-third of droppings or rotten dung, moderately dried. Road earth gathered in dry weather, and mixed with horse droppings, will answer.

Any other form of beds will answer, if made to throw off wet, like the roof of a house or hay stack. It is necessary always to guard against too much moisture when mushrooms are expected to appear.

Cover the bed with hay of a soft nature, or with straw, and water it very lightly, as occasion requires, with soft seasoned water.

The heat in the bed ought never to exceed 75° Fahr., when the thermometer is sunk six inches into it.

It is only in spring and summer that a regular supply of mushrooms can be got from beds in the open ground.

Rhubarb.—The wave-leaved rhubarb (*Rheum undulatum*) is the sort I generally grow. But I have found that the more common species, *Rheum rhaponticum*, comes a fortnight earlier than the wave-leaved; so that this is best for forcing. I prefer planting it in March. Take off sets from old plants, with two or three eyes, and with five or six inches of the root. Prepare for the reception of the

* That is, rotten couch-grass, or any other root-plants that farmers gather off their fields and put into rot-heaps.

offsets as follows:—Cut out a trench two feet wide, and two deep; lay the bottom of the trench with six inches of horse and cow dung, when rotten; and dig it in a full spade depth; then mix the earth that is dug out of the trench with dung, to enrich it; filling it four inches above the level of the ordinary surface, to allow for subsidence or settling. Set the garden-line along the middle of the trench. Put in the plants, so as to be two inches covered over with earth, pressing it gently to them. The plants should be three feet apart. If a large quantity of stalks is required, the distance between the rows ought to be four feet and a half. The quantity of dung I give is one large wheel-barrow load to every three feet. I am well aware, that much larger rhubarb may be produced by using extraordinary quantities of manure; but the large stalks so procured are always coarse. The rhubarb stalks will be found fit for use in three months after the planting of the offsets, and they continue all the growing season.

Forcing of the Stalks.—As rhubarb is a vegetable that is now in much request, I have turned my attention to procure a supply of the stalks as long as possible. I begin to force, in the open ground, about the middle of December. I cover each plant with a box or earthen can, and each box or can has a cover for the top: the cans are about two feet in height, twenty-two inches in diameter at the bottom, and nine inches at the top. Fill up the

spaces with tree leaves, mixed with a little stable litter, raising the fermentable matter about three inches above the height of the cans. If the weather is cold, it sometimes does not heat at that season of the year ; but a very small quantity of prepared dung wrought in among the leaves sets it to work ; it is then to be watched so as not to allow overheating, or so that the heat shall never exceed 75° Fahr. The heat is easily reduced, by slackening the dung around the cans ; or removing a few barrow loads, as may be necessary. Begin with covering in twelve plants ; in three weeks after, take in twelve more ; and in about three weeks, cover other twelve ; and these thirty-six stools will supply stalks till they come naturally. If the plants are in three rows, I take the middle row for the earliest ; for, when the rows on each side are covered, they act as linings to the middle row. When watering is required, I use soft-water, milk warm.

In gathering, pull the stalks out of the sockets, and do not cut any. Blanched rhubarb is certainly the best, being more crisp and delicate, with sufficient flavour, and less of the peculiar aroma of rhubarb. I am blanching it now by placing cans over it only. I intend to try retarding it, so as to have it late ; for I find it will not force to much advantage in the open air, so as to have it before the middle of January, although I have occasionally had the *rhaponticum* from about New Year's day. The second

year after planting answers very well for forcing. I think twelve new plants ought to be planted every year, so as to have a succession.

I have forced rhubarb in many other ways ; but what I state, is the way in which I have succeeded best.

I consider rhubarb stalks as particularly worthy of attention, as they are always highly relished at the table in the winter and early spring months. I shall be glad if what I have said lead some abler practical gardener to give us a better account of their culture and blanching. And am, &c.

PINKIE GARDEN, }
June 23. 1826. }

XX.

On the Ripening of Fruit by Artificial Heat after being taken from the Tree.

In a Letter from JAMES HOWISON, Esq. of Crossburn House, to the Secretary.

(Read 10th June 1817.)

SIR,

MAY I beg the favour of your communicating to the Horticultural Society, at their next meeting, the following particulars, respecting the ripening of fruit by artificial heat, after being taken from the tree, that any of its members may have an opportunity of ascertaining its effects by experiment.

My discovery of this circumstance was accidental, and occasioned by my being led, in 1815, to pull half the crops from a jargonelle and a moorfowl egg pear tree, some weeks before they could have been ripe, owing to the danger of their being stolen, from the exposed situation of the trees. The fruit was placed in the drawers of a book-case, standing in a room where a fire is constantly kept, and where the mercury generally ranges between 58° and 68° Fahr. during the twenty-four hours. At that time I had no view to any other advantage from this si-

tuation, than being the most convenient for keeping them. After ten or twelve days, on opening the drawers into which the jargonelle pears had been placed, I observed some of them to have a ripe colour, which, on tasting, I was greatly surprised to find much superior in sweetness and flavour to any that had ever before grown in my garden, when ripened on the tree in the most favourable seasons.

The moorfowl egg pears were nearly a month later, but with the same improvement, and both several weeks sooner fit for the table, than if allowed to remain on the tree.

When two pears of the same kind were given to any of my friends, the one ripened by artificial heat, and the other on the tree, they, from the difference of flavour, never failed in distinguishing them, and giving the preference to the former. Of this observation I have since taken regular advantage, and have extended it to melons, one-half the crops of which never arrive, in frames, at sufficient maturity, to be of any use but for preserving.

My success in this department, the following note, taken from my gardening memoranda, will explain: “*29th December 1815.*—The last of the melons, which were gathered in the end of October, and supposed useless, were, after lying since that time on the wooden floor under the book-case, eaten this day, and found nearly as high flavoured and juicy as those ripened in the frames, although they had but little smell until cut open. N. B. In fu-

ture all melons the size of apples to be carefully preserved. The green melon the best for this purpose.”

Last year, 1816, the season was so unfavourable, that, in this high country, Upper Ward of Lanarkshire, none even of the wall pears arrived at their usual size : still, the fire heat had the effect of rendering them more eatable than any I tasted ripened on the tree, which I had an opportunity of doing in one of the warmest situations in Scotland. I have often observed, that the aroma from a few apples put into a drawer amongst linen, if in a room where a fire was kept, was much greater than from as many dozen placed in a cold cellar.

From the foregoing it would appear, that the organic elaborations of the constituent parts of fruit are all finished in the early stage of their growth, *or when arrived at their full size*, and that their ripening is a process of chemical changes similar to fermentation, which, with a sufficient and regular application of heat, goes on, in some degree, independent of the living principle.

From the effect of fire heat on unripe melons, I have hopes that many of the fruits of warmer climates may be, by the same means, brought to a degree of perfection hitherto unattainable in this northern latitude from the heat of the sun alone. The degree of heat proper for each must be ascertained by future experience*.

* From some observations I lately made in germinating seeds,

On apples I have made no experiments ; for, except in seasons like the last, in this climate they arrive at sufficient maturity without any artificial aid. I must, however, notice some particulars with regard to their keeping last winter, which I think deserving of farther observation. In the end of October 1816, when my apples were gathered, even the Hawthorndeans were so green, that another month would have been insufficient to have rendered them ripe. How much then has been my surprise, that in no winter during these ten years have they been in so complete a state of preservation ; and even now, the 27th May, I have many codlins and Hawthorndeans equally fresh and plump as when taken from the tree. The cause of this unexpected occurrence appears to me owing to the great quantity of unconverted acid contained in the unripe fruit ; a knowledge of the effects of which, if I am correct, may be turned to several useful purposes. I remain, &c.

DOUGLAS, }
 2d June 1817. }

hatching of Canary birds, and making of vinegar, I am convinced that the degrees of heat best suited for these purposes, are more limited, or will admit of less excess or diminution than we are generally aware of; and, that animals, like vegetables, by a well regulated application of that grand mover of nature, may be forced in their productions. I have, at present, May 27. 1817, a Canary hen sitting on five eggs, which is her eleventh brood since the beginning of April 1816.

XXI.

On the raising of Mushrooms during the winter season.

In a Letter from Mr A. KELLY, Gardener to the Right Hon. the Earl of Moray at Donibristle, to the Secretary.

(*Read 9th June 1818.*)

SIR,

HAVING promised to communicate to you my method of raising mushrooms during the winter season, I shall now do so; and, if you think proper, you may lay this letter before the Caledonian Horticultural Society.

It may be proper first to mention, that the mushroom house that I have the charge of, is constructed somewhat agreeable to that introduced by Mr Isaac Oldacre in 1814, having shelves or boxes erected for the beds, in place of having them in pits, or on the floor of the house. But, as this plan is now generally known in the country, any further description from me would be useless. I shall merely state the particulars of my practice in making and managing the beds, in the above shelves, by which I have been enabled to obtain a good supply of excellent mushrooms during the whole winter months.

Every practical horticulturist will readily allow that spawn of a good quality is very necessary to insure success in growing mushrooms. After I have procured this, I next proceed to collect dung at the stables, in the mornings, not suffering it to be carried to the dunghil, but removing it to a covered shed, and there spreading it out thin to dry. I continue to do this until I have enough collected for the proposed extent of beds to be made, and I occasionally turn it, until it only retain moisture enough to cause a fermentation. I never found the dung to be too dry, providing it has not been allowed to heat. The kind of dung that I prefer is one-half horse droppings, and one-half short litter, from horses fed upon hay and oats, always avoiding dung of horses fed upon soft food.

As soon as a sufficient quantity is prepared as above, I carry it to the mushroom house, and throw it into a heap to heat, sometimes mixing one fifth or sixth part of sheep or cow dung; but, I have found beds, made of horse dung alone, prepared as above, to be equally productive, and the mushrooms of as good a flavour, therefore I have discontinued the use of sheep or cow dung in making mushroom beds. When the dung has been turned once or twice, and a good heat has come into it, I begin to make the beds, by throwing it into the shelves or boxes, and beating it as firm as possible. I allow the bed to be as high as the front of the shelf, or within an inch of the height of the front, the

shelf being one foot deep; the bed is made perfectly level. During the process of making up the bed, the heat of the dung will abate; but, by lighting a fire in the adjoining furnace for a short time, it will readily return: if it return strong, or become violent, I bore holes quite through the bed, to let the heat escape, and admit air freely into the house. These holes, by being filled up to within three inches of the surface of the bed, answer for putting the spawn into. As soon as the heat becomes mild, I spawn the bed with pieces of spawn about the size of common plums, placing the pieces about nine inches or a foot distance from each other, and covering them one inch below the surface of the bed. I have sometimes put on the mould directly after spawning, when there was no danger of the heat returning strong; but, in general, I defer this until the spawn has spread itself through the dung, which I think answers better.

I have tried different kinds of mould for mushroom beds; and what I have found to answer best is, lightish loam, mixed with a small proportion of horse droppings or road scrapings. I find road scrapings, when they can be got dry, and from roads where horses have frequented, to form an excellent composition for covering mushroom beds.

I put the mould on the beds one inch thick, beating it firm and smooth. This finishes the bed to the height of the front of the shelf, or one foot deep.

Thus having given you a detail of my way of preparing the dung, making up, and spawning the beds; all that is now required until the mushrooms begin to appear, is to keep a steady and regular degree of heat in the house, admitting air at all opportunities, and regulating according to the heat in the beds. I keep my house from 55° to 60° of Fahrenheit's thermometer. The mushrooms generally begin to appear in about three or four weeks after the mould is put on. If, at this time, the beds look very dry on the surface, I give a very moderate watering, with seasoned water, suited to the temperature of the house. If the spawn has extended itself, and the bed is in good condition, the effects of this watering will soon be very visible, by sending up mushrooms in great numbers, and in large clusters, all over the bed. The admission of air into the house at this time is very beneficial: by admitting much air, the mushrooms will not advance so rapidly in growth; but they will be much firmer, and of higher flavour, than if kept close shut up. I use no covering for my beds.

Watering of mushroom beds is a very delicate operation, and ought to be performed with caution, as the spawn will not long exist in the beds, if they are too moist; and the mushrooms will often go off after they are as large as peas: therefore, I keep my beds rather dry, not watering as they appear to want it, but according as I want a supply of mushrooms; for if the beds are in a good state, they will seldom fail

to produce plenty, after a moderate watering is given. Upon the regulation of the watering depends the length of time that the beds will continue to produce. After my beds appear to be quite done bearing, and if there be any spawn remaining in them, I allow them to lie a considerable time quite dry, during which the spawn will extend itself a second time, and by applying a moderate watering, the bed will frequently again produce very good mushrooms.

Thus I have endeavoured to give you the particulars of my mode of raising mushrooms. Although it may be said that little new is stated in it, yet to some it may be useful; and I hope those who may have better methods will be induced by it to give their opinion upon the subject.

This way of raising mushrooms, in shelves and boxes, has met with opposition from some; but I think it has advantages over the common way of raising them in pits, or in ridge beds. First, any extent of beds required may, with the greatest convenience, be set agoing at a time; and far less materials will be found to answer the purpose. But the greatest advantage that it possesses over the common practice, consists in the beds being elevated above the floor of the house; no damp can arise therefrom; and the bottom of the shelves, being constructed with openings below, all superabundant moisture is readily drained off. Besides, these openings are very serviceable, by admitting the heated

air of the house to the under part of the beds; which will be of good effect, after the fermenting heat of the dung is gone. An objection to this way of raising mushrooms may perhaps be advanced, that the beds being composed of a small body of dung, they will not continue to bear so long as those made after the common way; but, in both cases, I think the continuation of their bearing depends very much upon the materials used, and the general management of the beds. Too much moisture and dampness being, in general, the destruction of all mushroom beds, those made upon the floor of the house are more subject to this evil than those made upon the shelves; and the circumstance of their being composed of a much larger body of dung, will of itself, when the beds begin to decay, raise a damp that will gradually ascend and destroy every particle of spawn. I am, &c.

DONIBRISTLE, }
May 2. 1818. }

XXII.

*On destroying Slugs (Limax cinereus, and
agrestis.)*

In a Letter from MR ARCHIBALD GORRIE, Gardener to
KENNETH BRUCE STUART, Esq. of Annat, to the Secre-
tary.

(Read 9th June 1818.)

SIR,

THE rain which prevailed from the beginning to the middle of the present month (May) have called vast numbers of slugs into existence ; and the depredations they commit are found to be commensurate with their numbers. The complaints at present on this subject are many, and but too well founded. On some fields of oats the *braird* has been partially devoured by them, and on others the plants have entirely disappeared. In the garden, where they are always troublesome, they have this season become formidable ; and where whole flower-potfuls are picked off every morning, they still continue to increase, and to eat up the different varieties of the brassica tribe, and seedling plants of almost every sort ; and even in some instances do

they ascend wall-trees, and attack their expanded blossom.

It is almost universally known that quicklime dusted over slugs kills them instantaneously. Lime water, too, has been recommended for the same purpose; but lime loses that caustic quality by which it destroys them, soon after it is laid on the ground, and consequently can afford only a transient protection to the plant which it surrounds. Lime-water is also liable to the same objection; so that if lime is applied in any shape for the destruction of slugs, it must be repeated almost daily to keep them under.

It is not perhaps generally known that the urine of black-cattle, or the drainings of a cow-house, or of dunghills, destroy slugs, if poured on them. Such liquids also prevent the approach of others for a considerable time to the ground on which they are poured.

This discovery, if it deserves the name, was made by accident last season; and since that time I have found nothing further necessary to preserve my plants from slugs, than to pour a little of the drainings of the cow-house, diluted with about one-third of its quantity of water, over them once a fortnight. Every practical gardener will know that, in clear weather, the watering should be performed in the evening; and that it may be done any time throughout the day, in damp or cloudy weather. If the

urine is applied without any mixture of water, it will the more effectually destroy the slugs ; but it may also be in danger of hurting the plants, unless applied in the time of rain, when it will prove a protection to the plant, and at the same time promote its growth.

Your laying this short communication before the Horticultural Society at your convenience, will oblige yours, &c.

ANNAT GARDEN, }
21st *May* 1818. }

XXIII.

Account of a New Mode of Planting and Cultivating Fruit Trees, with a view to prevent Canker, and to procure well-ripened Fruit.*

By MR ARCHIBALD REID, Gardener to the Hon. ROBERT LINDSAY, at Balcarras, by Colingsburgh.

(*Read 2d Dec. 1824 and 2d Nov. 1827.*)

I WAS entrusted with the management of the extensive gardens and orchard at Balcarras in the end of the year 1812. The orchard contains about two Scots acres, and was stocked with upwards of 600 trees; I found these numerous fruit trees generally in a very unhealthy state, being much infected with canker. During the first season, I examined the soil, and found it consisted of a strong cold loam, of various sorts, and in general about three feet deep, on a subsoil of cold clay. I lifted a few of the trees

* At a General Meeting of the Society, held 6th March 1828, it was resolved that the London Medal for 1827 should be awarded to Mr Archibald Reid, for this communication, the advantages of the practice recommended having now been amply confirmed.

most infected with the canker, in order to ascertain the situation and state of their roots, and found they had run generally to the depth of three feet, as the spots whereon they were planted had been paved with flags at that depth. The roots were clean and healthy, but few in number, mostly of a very large size, and had very few fibres. I am of opinion that the depth of the roots and the want of fibres, even in the most favourable soil, must have a tendency to injure the health of the tree, and to produce canker. I was induced, from the state of the roots being so deep, and the diseased state of the trees, to hope, that, if new trees were planted near the surface, the roots would become more fibrous, the trees more fruitful, and be less apt to canker.

In 1813 I made some experiments, by covering several thermometers, for about fourteen days, close in pits of various depths, in order to ascertain the degrees of heat; and found during the summer months the average heat at 6 inches to be 61° ; at 9 inches 57° ; at 18 inches 50° ; and at 3 feet deep 44° Fahr. I therefore concluded, from these experiments, that if the roots could be retained near the surface, they would be in a more favourable situation than when allowed to run two feet or more down in the soil. In autumn 1813, a few of the diseased trees, of about ten years standing, were dug up and planted as near the surface as their roots would admit. These have continued ever since to improve, and are now bearing annually good crops, and are perfectly free of

canker. But as there was little hope of these trees succeeding at the time of their removal, preparation was made for planting young trees, by collecting mould, composed one-half of decayed vegetables and tree leaves, and the other part of fresh loam, from the surface of old pasture ground, to which was added one-fifth of sharp pit-sand; all these parts were well mixed together, and after being properly decomposed and turned over, this compost was, during the following summer, carried into the orchard, and laid down in heaps of about three to four wheel barrow loads to each tree. The ground having been previously trenched to about two feet deep, and the distances of the trees marked out, a stake of from three to four feet long was driven into the ground, about six inches north from the site intended for the stem of the tree, where a circle of six feet diameter was drawn, and the soil within it was removed to the depth of two inches. The place was then beat with a wooden rammer, and made as firm and smooth as possible, and of an equal depth all over. Before planting the tree, the roots were carefully examined, and all bruised or broken parts cut off, leaving the slope upwards. The tree being placed at six inches south of the stake, one person held the stem fast, while I spread out the roots on the beaten surface of the circle, placing, if possible, the greater part of their extremities to the south; the tree was then pressed gently down, in order to make the roots rest close on the surface. As soon as the roots

were adjusted, a third person laid on the fine mould, which I carefully distributed among the roots, pressing it with the hand till the roots were all covered. The remainder of the mould was then placed in a conical form, from the extremity of the circle to the stem of the tree. The place was then covered over with a little half-rotten dung, and this last covered with the earth first thrown out of the circle. About two feet on each side of the stem the earth was flattened, and left in this state *. The stem of the tree was then made fast to the stake with a hay band. If any of the large roots happen to be broken near the stem, before or during the operation of planting, as the new fibres of such roots are apt to force their way downwards, I always mark such trees, for the purpose of lifting and replacing after about four years standing, in order to give the fibres of the broken root a horizontal direction, if found necessary.

In spring 1815, about eighty trees, of the usual size, were ordered from the nurseries, and planted as above mentioned; but I found, from the large size of their roots, that a number of them were broken during the operation of planting. To remedy this evil, a quantity of young trees were procured from the nurseries, only one year grafted; these were planted, in the manner above described, in a plot

* In the year 1808, I planted a considerable orchard on the same plan; but as the ground was afterwards dug for vegetables, the plan did not succeed, owing to the roots being injured by the spade.

prepared for the purpose, in rows three feet separate, and two feet distant in the row. They were allowed to remain three years in this state, and then transplanted as directed. I found, by this operation, the roots abounded in fibres, and had acquired a horizontal direction according to my wish, and were easily removed to their new situations on a hand-barrow, the fibres retaining a great quantity of the soil when lifted. In pruning these young trees as ordered from the nurseries, I cut down their shoots to about six inches long, leaving only three shoots, the top bud on the north side being allowed to remain, so as to form an open head towards the south. When transplanted into the orchard, none of the young shoots were cut down; only a few of the ill placed ones were cut out: for the shoots of the former season when allowed to remain whole, generally produce blossom buds, and upon these buds, or natural spurs, the best fruit is always produced; but, on the contrary, were these shoots to be shortened, they would, in that case, produce few such buds, but, instead thereof, would send out a great quantity of useless wood; and the tree would not be in condition to produce much fruit, so long as the young shoots are cut down in this manner.

As the trees acquire more wood from their age, the knife may be used more freely, always keeping the tree open towards the south, and the branches from crossing or rubbing upon each other. I generally keep them from nine inches to a foot sepa-

rate, according to their sorts or state of growth, carefully examining the tree for such buds or spurs as have been injured by pulling the fruit, or other accidents, for if these are allowed to remain, they will in most cases produce canker.

When trees are planted in the above manner, they do not grow to a great size, nor require to be planted at a great distance. I generally allow twelve feet square to each tree, and, as the ground cannot be used for vegetables owing to the roots being so near the surface, I keep the soil as clear of weeds as possible, particularly during the summer months, by using the Dutch hoe, as this instrument may be used with great expedition, without injuring the roots of the trees. I am of opinion, that breaking the surface by hoeing and raking in dry weather, promotes the health of the tree, as well as the flavour and timely ripening of the fruit. For raking, I use a wooden rake, as it is not so apt to tear up the young roots*.

A top-dressing of rich compost is given once in three or four years, and laid on before winter.

Those trees that have been planted and cultivat-

* *October 1827.*—I am of opinion that the welfare of an orchard, placed on an unfavourable cold soil, does not depend merely on shallow planting, but relies very much on the treatment afterwards; it is necessary to retain the roots in the situation first given to them. If the ground is ever dug for cropping after the trees are planted, the plan will not succeed; but gooseberry-bushes do well amongst the trees without the ground being dug.

ed in the above manner, are more moderate in their growth, and easier kept within compass of pruning; the wood is of a firmer texture, and much less apt to canker; they are much more fruitful, and the fruit of finer quality, and about three weeks earlier ripened than the fruit of the old trees that have been allowed to remain. This must be owing to the heat of the sun reaching their roots situate so near the surface, and thereby producing a more rapid vegetation, and bringing both wood and fruit sooner to a state of maturity.

I have been told by various classes of visitors, that by allowing such young trees to bear so great quantities of fruit, they would soon be worn out and decay. I allow this may be the case in some measure with trees planted and cultivated in the usual manner, by digging and raising kitchen vegetables among them, whereby the roots are forced to seek nourishment in the unfertile subsoil. The case of trees planted on the surface, and feeding among the rich warm particles of a fertile soil, must be far preferable indeed, where the roots are never injured by the spade, nor the action of the atmosphere obstructed by crops of vegetables. Further, the young trees have hitherto done well, and at present have a very promising healthy appearance*. But even

* *October 1827.*—Some of the old trees have been allowed to remain in their original state, and are sadly infected with canker, and their fruit of no use, as it does not ripen. The young trees continue healthy and vigorous.

suppose they should decay, as remarked, at the age of fifteen or twenty years, it may be answered, that the fruit already produced by them is a sufficient inducement to continue the practice, by keeping up the succession from a nursery of young trees. It may be added, that those young trees have no tendency to canker except from broken buds or accidental bruises, which is of little consequence, as they are cut off during the pruning season; but many of the old trees were much infected with the canker at six years old, and, when about nine years old, they were generally overrun with this disease, when the above new mode of planting was introduced.

Although canker is produced from various causes, the principal cause, I think, is deep planting in any soil, as that method is generally attended with the production of unripe wood.

In a strong deep soil, the growth is apt to be luxuriant, and the wood spongy with buds, neither of which are brought to maturity; these are often destroyed by the vicissitudes of the weather during winter, and thereby canker commences, which seldom fails to destroy the branch where such buds exist.

In a dry subsoil, the tree being deprived of nourishment, both from poverty of soil and want of moisture during the summer, vegetation often becomes stationary, and, towards autumn, sometimes is succeeded by a new growth of wood, liable to the same disease as the former.

A few of the old trees being left unremoved for the purpose of experiment with regard to the canker; after twelve years experiment and observation on these old trees, I have been led to the above conclusions respecting the causes of canker. Although, by great attention in pruning these old trees, and cutting out the canker, I have succeeded in preserving them up to this period (November 1824), their fruit is of inferior quality, and so late in ripening, that it makes a poor return for the great trouble necessarily bestowed on them.

As a confirmation of the above plan of planting on the surface being preferable to the common method, I have at present a great number of the branches of these young trees, regrafted with cions taken from the most diseased of the old trees, particularly the Hawthorndean apple and the Jargonelle* pear, and several other sorts, commonly supposed to be most subject to canker. All these new grafts are doing well, and have carried good crops for the last six years.

* *October 1827.*—I allude to jargonelle trees planted against the wall, which were very much infected with canker. I now add, that I have about eighty standard pear trees of various sorts, about three years old, which produced a considerable quantity of fruit this year for their age, and appear as healthy as the standard apple trees.

[This communication was accompanied with the following letter, addressed to the Secretary by the Hon. ROBERT LINDSAY of Balcarras.]

SIR,

Balcarras, 29th Nov. 1824.

THIS letter accompanies a paper written by my gardener, stating his observations on the disease called Canker in fruit-trees; also the mode he adopted in planting out a new orchard of apple trees at Balcarras in Fife. Allow me to mention, that nothing could be more unfortunate than the soil chosen by my predecessors for the garden and orchard at Balcarras: the elevation about 220 feet; the soil a retentive clay, with a cold tilly bottom. The consequence was, that, for twenty years, I tried to establish an orchard without success. With the force of dung, the trees grew to a luxuriant size, but the wood cankered, and produced no fruit. Under these untoward circumstances, Archibald Reid, my gardener, proposed a new plan of replanting the trees, within a few inches of the surface, treading down the soil, to prevent the roots going down, thus forcing the smaller fibres to run horizontally along the ground. At the same time, he raised up some of the old diseased trees to the surface, carefully cutting out every particle of canker. The experiment completely succeeded; and I have now the satisfaction to inform you, that there is not a more

productive orchard in Scotland than the one I now allude to, or one more deserving of the attention of those who have to work upon a cold bottom. For these advantages, I am indebted to the superior judgment of Archibald Reid, to whose statement I refer.

Mr Andrew Dickson, treasurer of the Society, who has annually seen the progress of the work for the last twelve years, will give his testimony as to what he has seen, and fully confirm all that is here stated. I am, &c.

[The following notice on the same subject is from Colonel SPENS of Craigsanquhar, a distinguished amateur horticulturist.]

Successful Mode of Planting Fruit-Trees at Balcarras, the seat of the Honourable Robert Lindsay.

THE soil of the garden and orchard is on a cold wet retentive bottom, and the trees had been planted in the usual way by digging a pretty deep pit for them; the roots were consequently in an unfavourable situation, and far removed from the kindly influence of the sun. The fruit which the trees produced was therefore not good; the trees

were not productive, and they were sadly infected with canker, as is still very visible from some of the old ones which have been allowed to remain. To remedy these various evils, young trees have been planted in the following manner, which has been attended with the desired effect, they being now very productive, ripening their fruit more early than formerly, while it is also much better; and they are hitherto free from canker, though they have now (1827) been planted eleven years.

A circle is drawn on the surface of the ground, containing a space of about six feet, which is rendered smooth and hard by being beat with an instrument similar to what paviers use in causewaying a street. Young trees which have only been transplanted a year or two are preferred, from their roots and fibres being more flexible and pliable. In the centre of the circle, and on the surface, the trees are placed, and held upright by an assistant. The roots and fibres are carefully spread out and severed, and covered over with about six inches of fine mould, brought for that purpose on a wheelbarrow. The trees are fixed with a stake, until they acquire sufficient firmness in the ground to resist the effects of high winds. It is, however, to be remarked, that ground occupied by trees in this manner soon ceases to admit of cultivation, and cannot be dug, from the injury this would create to the roots; but perhaps it might be laid down with grass-seeds, and the surface might be occasionally

enriched by the application of a proper top-dressing*.

The trees thus planted at Balcarras have been selected with much judgment by the gardener, from the more hardy productive Clydesdale kinds, and they seem to be managed with much attention and skill. They are not permitted to become too luxuriant, and they are so pruned as to admit the full influence and benefit of the sun.

* *October 1827.*—I have tried grass, but it does not answer. The fruit of the trees become small, and are late in ripening; and the trees become subject to moss.—A. R.

XXIV.

Observations on the Culture of Onions.

Communicated in a Letter to the Secretary from **ANDREW DUNCAN** *sen.* M. D. and P., dated 1st September 1818.

(*Read 8th September 1818.*)

DURING the course of the present summer, I have visited many gardens, particularly in the three Lothians and Fife. I have very generally found, that, almost every where, the crops of that excellent vegetable the onion were deplorably bad. This every gardener with whom I have conversed attributed to their being destroyed by the grub peculiar to onions. The same devastation has taken place in England; insomuch that I am told peaches and onions are now sold in Covent Garden market at the same price.

To the generation of this insect, the warm and dry weather which has prevailed this season has been particularly favourable, and therefore its ravages are not wonderful. But to this general destruction of the onion, I have found one very remarkable exception. In the gardens at Dalkeith Park, which

I visited in conjunction with my worthy friends Professor Dunbar and Dr Andrew Brown, I have seen this year one of the finest crops of onions that I have ever beheld, during the course of a long life. This I have no doubt in ascribing to Mr Macdonald's superior mode of cultivating that vegetable.

Mr Macdonald has this season been engaged in many experiments, with the view of improving the culture of onions, particularly for determining the comparative influence of different kinds of dung in promoting the growth of that vegetable. The result of these experiments I would fain hope he will in due time communicate to the public. But the two particulars on which, in my opinion, the excellence of his onion crop principally depends, he has already made public through the medium of our Memoirs.

In a paper, printed in our Memoirs, vol. i. p. 111, *et seq.*, he has recommended two different practices : 1. The transplanting of onions ; and, 2. The defending the plant against the grub by means of soot. For a particular account of these practices I must refer to the paper itself. I shall only observe, that, from the appearance of his crop, there was every reason to believe that his mode of applying soot is an effectual protection against the grub : For while, in other gardens, the grubs had made very great devastation, in his transplanted rows not a single blank was to be observed. The advantages of transplanting was no less manifest in the size which his

onions had acquired. To this plan of transplanting onions, Mr Macdonald was first led, from the very great improvement which transplantation makes on leeks. I am old enough to remember the period when transplanted leeks were very rarely to be met with in any garden. But such is the benefit resulting from this process, that now almost no leeks are considered marketable which have not been reared in that manner. I do not despair of living long enough to see the transplanting of onions become as general; for I am persuaded it will be attended with no less advantage. Indeed I am informed, on authority on which the most perfect reliance may be put, that the transplanting onions has been long the universal practice at some of our settlements in the East Indies. Dr P. Baird from Bombay, a worthy and intelligent member of our Society, informs me, that, at many different parts of the Malabar coast, onion plants for the purpose of being transferred to other gardens, are as currently sold as cabbage plants are in the Edinburgh market. I would therefore fain hope, that, by due attention to the plan which Mr Macdonald has recommended, the industrious gardener will not in future be subjected to the same calamity, with regard to onions, as has occurred during the present year.

P. S.—As a postscript to my letter, I add an extract of a letter from JAMES WARRE, Esq., dated.

30. George Street, Hanover Square, London, 10th January 1818.

“ Observing in the newspaper of this morning, in the report of the proceedings of the Caledonian Horticultural Society, that Mr Macdonald of Dalkeith presented a basket of *transplanted* onions, that, for size and firmness, surpassed any other exhibited, I take the liberty, as a member of the Horticultural Society of London, very desirous of promoting the objects of both institutions, to offer to your honourable Society a sample of Portugal onion-seed, from Vianna, in the province of Minho,—the quality of onion most esteemed in that country.

“ The advantage of transplanting onions, to promote their growth and size, as practised in Portugal, I frequently have submitted to gardeners here, and am happy to find that this process has been attended with success in a northern part of the empire. The practice in Portugal is, to sow the seed about the end of November or December, on a moderate hot-bed, covered with a few inches of rich good mould, in a warm situation, merely sheltered from their slight frosts by mats. When of about the size of a *large* swan's quill, or about April, they are transplanted on a rich light mould, well manured, *with old rotten* dung, the plants at the distance of about nine inches each way, generally in beds, for the convenience of access, laying the plants flat, covering lightly the beard or root,

and *part only of the bulb*, with rich mould, well mixed with two-thirds of old rotten dung ; watering, if the weather is dry, until they have taken root ; subsequently occasionally breaking the earth by lightly hoeing, keeping them perfectly clean from weeds, watering frequently, according to the state of weather. There, they have frequently means to water by irrigation, when, upon rich soils, they can grow them to a great size, particularly when they let the water run through small heaps of dung, though, when that is practised, or much water given, the onions do not keep so long as others. When ripe, they draw them gently from the ground, give a twitch to the tops, and leave them to season on the ground for a few days, before housing, when they directly bind them into ropes with *dry* straw, not permitting them to sweat in a heap. Their preservation much depends upon the weather being dry and good when housed, and on their not being bruised.”

XXV.

Remarks, 1. On the propagating of certain Plants by cuttings; 2. On enuring of certain Plants to our climate; 3. On the grafting of Orange-Trees.

In a Letter from Mr JOHN MACHRAY, Errol, to the Secretary.

(*Read 2d February 1826.*)

SIR,

THE following remarks on several subjects connected with horticulture, the result of long and successful experience, I now forward to you; and should they appear of sufficient importance, I shall feel obliged by you laying them before the Society. There are many plants, that, from their hard texture or peculiar organization, are very difficult to propagate by cuttings, but there are but comparatively few that have not been found, under proper management, to produce those appendages which are requisite to promote the growth, and prolong the existence, of the species. Nature, indeed, employs other means of propagation, but her hand-maid Art has proved successful in propagating many useful and ornamental vegetables, the seeds

of which cannot be easily obtained in a climate where they are not indigenous,—by laying,—by cuttings,—and by grafting. The approach which nature may have made to propagate the species by any of these methods, is very limited. The process of *laying* is the most obviously natural, next to the universal law of every tree yielding fruit “in which is the seed thereof after his kind.” The mode of grafting, by which *varieties* are propagated, may have first been adopted from the appearance of cross branches uniting, after long continued and severe pressure against each other; but the origin of striking by *cuttings* is not so easily accounted for, nor shall that investigation be made the subject of the present inquiry. I shall confine myself, on this subject, to a description of the method I have long practised, in propagating certain plants by *cuttings*. I shall next mention the success attending the exposure of certain plants to the action of the weather, in attempting to enure some of the natives of warmer countries to a climate which, according to meteorologists, gives a mean of 47.2° Fahrenheit. I shall, lastly, take the liberty to state my mode of grafting orange-trees, with the attendant success. I am aware that a communication on this last subject has already appeared in the Society’s Memoirs. The rapid progress, however, which this method of practice insures, convinces me that a description of it will not be altogether uninteresting.

1. Among the plants to which this paper is meant to excite attention, as raised by cuttings, are the *Aster Argophyllus*, *Pyrus Japonica*, *Aucuba Japonica*, the stripe-leaved Bramble, and the broad and the narrow leaved Myrtles. The compost I use for such cuttings, is of an open nature, and at the same time contains as much nutritive matter as is requisite to communicate sufficient vigour to the young plants when rooted: it is made up of one-half light-brown loam, one-fourth vegetable mould, and one-fourth river sand, well mixed, and put through a sieve. The time which I prefer for planting, is from the middle of August till the middle of September, when the shoots have acquired sufficient firmness. The place I choose for planting the cuttings, is in front of a north wall, a south aspect, the hand-glasses to be about six inches from the north wall, and as near the west corner as to be within the shade of the west wall in the afternoon. After marking the space for the glass, I take out the natural border earth, to the depth of eight inches, and that space I fill with the above mentioned compost, treading it gently. I then put in the cuttings, prepared in the common way, with a small dibble. The cuttings are of last summer's growth, and from 4 to 6 inches long; they are placed from $1\frac{1}{2}$ to 2 inches apart from each other, according to the strength or size of the cuttings. I firm them well, and give a good watering. I then cover close up with the hand-glass, shade from hot

sun in the months of August, September, and October; but I keep off the mats during the winter months, and put them on again in March. I continue to shade in time of hot sun till August, visit occasionally during that time, and give gentle waterings from the beginning of May. By the end of June, the cuttings will have struck root, and by the end of July they will have acquired from 6 inches to a foot of young wood. During this period, they will require more frequent watering and shading throughout the day. I may here observe, that no air is to be admitted to the cuttings from the time that they were planted till now, the end of July, except what was unavoidable during the time of watering. About the 12th of August they may be potted out; and it will strengthen the plants to have a little air admitted every day, by little and little, for about a fortnight before potting. I formerly propagated that beautiful plant the *Pyrus Japonica*, by cuttings of the roots; but by this process comparatively few plants can be raised: It seems unnecessary, however, to enlarge regarding this plant, as it is now found to be most successfully and easily propagated by layers.

2. I shall now notice a few of those plants which I think I have in some measure succeeded in enuring to our climate, or which I have been able to preserve in our open borders, by a little care and protection during winter.

The *Aster Argophyllus* I have growing against a south wall, where it has stood three years, and is 6 feet in height; it requires little or no protection in winter.—*Myrtles* grow here on the open walls, to the height of 10 feet. I cover them with a mat in winter.—The *Aucuba Japonica* grows in the open borders, but is much improved in growth, and beauty of foliage, on an east or west wall.—*Fuchsia coccinea* succeeds in the same way, and grows here against a south wall, and is advanced to the height of 7 feet; flowers richly from June till November. I cover in winter with mats.

3. The stocks I use for orange-trees are from four to six years old. I prefer lemon stocks. The season for grafting is early in March. The method I prefer is what is called *slit-grafting*, which will be easily understood by every practical gardener. I use no clay, but tie a little moist moss round the parts joined. I plunge the pots in which the grafted stocks are, into the tan-bed in the pine-stove, and give a good watering. I then cover closely with a hand-glass and shade from hot sun in the middle of the day. In ten days they will begin to push, and will have acquired, in another fortnight, fully a foot of young wood: then air should be very gradually admitted; and, in a few days, the moss and bandages should be removed, and the plants, after having the advantage of the hand-glass for a few days after uniting, may be removed when thought proper. By this method ninety-nine in a hundred will

succeed. I have often had flowers on those plants the first season. I have also found those plants grafted, yield more flowers and fruit than plants that had been budded. I may also remark that, to secure or rather promote a growth in the stocks, before grafting, I remove the pots containing the lemon and orange stocks, from the greenhouse to the pine-stove, about eight or ten days before the operation of grafting takes place. The process of vegetation then goes forward; the stocks and graft under the hand-glass join much sooner than those who have not witnessed that process might expect; and I conceive, that, in this rapid junction and subsequent vigorous growth produced by the partial exclusion of air, the elevated temperature, and the early period of the season at which I graft, lies the principal merit of the process I recommend. You will likewise observe that, by this process, good orange plants may be obtained within a month from the time of grafting. The scions I use are short, only three buds above the tying, and in general of last year's growth. If this method of grafting is performed in a hot-bed, where pine-pits cannot be had, bell-glasses will be most convenient for covering the stock and graft.

The rapidity of growth obtained by the practice I have here described, compared with the result obtained by following the usual modes, will, I hope, justify me in submitting it to the public. The cul-

tivator of orange plants will find many useful hints for the after-treatment of orange trees, in Mr Henderson's excellent communication in the 11th Number of the Society's Memoirs, (vol. iii. p. 306, *et seq*). I am, &c.

ERROL PARK, }
27th January 1826. }

XXVI.

Description of an Improved Flower-pot, with an interior Moveable Bottom.

In a Letter from JAMES HOWISON, Esq. of Crossburn House to the Secretary.

(Read 2d September 1824.)

SIR,

ACCOMPANYING this, you will receive a model for a new Garden Flower-pot, as also, one for a Shifting Stand, both of which, I hope, the Society will, in several respects, find superior to the utensils now in use for the same purposes*.

My objections to the present garden flower-pots are, that their bottoms, in nineteen instances out of twenty, are little more than one-half the width of the top, although the bottom is the part the roots of plants principally occupy. From this cause, in

* These models may be seen in the Council Room, at the Experimental Garden, Inverleith. It may be right to notice, that the figures of the perforated false bottom in the margin are proportionally too small; they should nearly fill the interior of the bottom of the flower-pot.

green-house shelves, where the pots contain plants with small heads, half the space occupied by a wide mouthed flower-pot is lost. To remedy this, it will be observed, that my flower-pot is almost a cylinder, or the taper towards the bottom is only sufficient to admit of the ball of earth which surrounds the root of the plant leaving the pot easily, after being loosened by placing it on the shifting-stand, and that, instead of putting gravel into the pots,

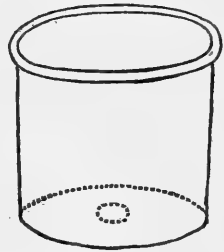

to prevent the water stagnating, I substitute a *perforated false bottom*, made of the same materials as the pot (fig. 2.): these false bottoms have the holes much wider in the lower than in the upper side (as is seen in the section, fig. 1), and this will, in a great measure, prevent the holes filling with earth. In pots sufficiently large

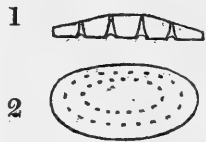

for auriculas, polyanthuses, and all other flowers of that size, the holes in the upper side may be so minute, as to prevent the possibility of worms entering through the bottoms of the pots while placed out in summer. The rim of my pots, in place of being round and projecting, is flattened; by which means they can be ranged closer with less danger of chipping. In the largest sized pots, used for camellias and orange trees, the projecting rims ought to be continu-

ed, as affording a firmer hold. The heads of such plants are generally too large to admit of the pots being placed close to one another. It was the difficulty I experienced in taking the large plants from their pots that led me to the use of the shifting-stand.

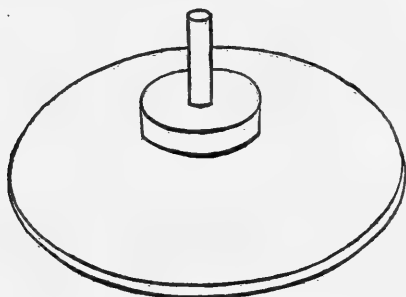

Till I adopted this contrivance I knew of no other method than dragging the plants out by their stems, which often required a force which entirely separated the roots of the plant from the ball of earth. It is scarcely necessary to notice, that the false bottoms must be made strong in proportion to the size of the pots, so as to bear the pressure of the shifting stand, and as the perforations must also be larger, it may be necessary to place over these a little dried moss before the earth is put into the pot, to prevent their filling up. The false bottom passing down the pot easily will serve as a gauge to ascertain that the mouth of the pot is larger than the bottom. I am, &c.

CROSSBURN HOUSE, }
28th August 1824. }

Extract of a Letter from Mr HOWISON to the Secretary, dated Douglas, 20th September 1824.

I am glad the flower-pot shifting stand met with the approbation of the meeting generally. I should hope the objections noticed by you will not be found in practice so formidable as anticipated. I may allege, that, for several years, the moveable bottom and shifting stand have, in substance, been constantly used by me, from my placing in the bottom of each of my flower-pots a piece of slate or broken pot, of a size as nearly to cover the bottom as I could conveniently select. This I did with a view to its carrying up the earth and plant when placed on the pin of the stand, at the shifting season. I do not recollect an instance of the slate or shred breaking in the course of the operation. Should there be any fear of that, the moveable bottom might be made thicker in the centre (Fig. 1, which is a section of the bottom piece made thicker in the centre), which would do away all probability of its breaking. The hole in the bottom of the pot should be of considerable width, and the pin in the shifting stand so thick as exactly to fill the hole, by which the pressure will be more equally diffused. Where a great variety of flower-pots are in use, stands with larger and smaller pins will be necessary.

I cannot easily conceive how the perforated bot-

tom should be more liable to have the roots of plants penetrating it, than the broken shreds or gravel now in use. There are no holes near the centre, where the pin of the stand is applied, which serves two purposes,—that of giving strength to the bottom, and of preventing any roots penetrating where the pin comes in contact with it.

Crossburn House, 15th March 1828.

FOR these three years past I have used the new pots with great satisfaction in my green-house; the Messrs Dickson, nurserymen and florists, Waterloo Place, having got a commission for a quantity of pots of all sizes given them by me executed (at the pottery employed by them) in a very complete manner according to my plan.

XXVII.

*Remarks on some Species of Edible Gourds, and
on the Modes of Dressing them for Table*.*

In a Letter to the Secretary from Mr DANIEL CRICHTON,
dated Minto Garden, 19th November 1827.

(*Read 6th March 1828.*)

SIR,

I OBSERVE by the Caledonian Horticultural Society's Prize Schedule for 1827, that edible gourds form a subject thought worthy of consideration.

I have for a good number of years bypast been in the practice of cultivating the Vegetable Marrow, and several species of gourds, for culinary purposes ;

* At a meeting of the Council and Committee, held at the Experimental Garden 3d April 1828, " the meeting, considering that a medal was last year offered for the best communication on edible gourds, and being of opinion that the paper by Mr Daniel Crichton at Minto House, with the account of the mode of dressing gourds by Mr Desaurty, form a most deserving communication, agree in voting to Mr Crichton the Society's silver medal."

yet amongst the many varieties that have come under my observation, there is none that I have found so valuable as the variety called the Vegetable Cheese, or Cheese-Gourd, a large specimen of which I have sent to Messrs Dicksons and Company, Waterloo Place, which weighed, when new cut, above one hundred weight. When ripe, the skin is very thin, and the eatable part much thicker than in any other gourd that I know of; and being of a firm sweet substance, it is well adapted for culinary purposes. I believe the vegetable marrow is in general cultivation. The vegetable cheese will do with the same culture; and, like the vegetable marrow, it can be used for culinary purposes before it is ripe. With us the vegetable marrow is only used when about half grown. The vegetable cheese also answers very well when in a growing state, although much better for some purposes when arrived at maturity; it is therefore held in more esteem with us. But it is a fact well known to us all, that they, as well as many other kinds of vegetables that are cultivated to the highest state of perfection by the gardener, are still much improved by coming through the hands of a judicious and experienced cook. I therefore subjoin receipts for cooking the vegetable cheese and the vegetable marrow, as used at Minto by Monsieur Victor Desaurty, a cook eminent in his profession.

To make Soup of the Cheese-Gourd.

TAKE the fleshy part of the gourd, when ripe, and cut it into small pieces; put it into a pan with a small bit of butter, set it upon a slow fire until it melt down to a puré; then add milk in the proportion of half a gallon to four pounds of gourd; let it boil a short time, with a little salt and sugar, enough to make it taste a little sweet; then cut some slices of bread very thin, toast it very well, and cut them into small dice; put them in a dish, and pour the puré over, and serve it up.

Cheese-Gourd dressed in the Spanish way.

WHEN ripe, cut the fleshy part into slices about an inch thick, score it across into small dice, about half through one side of the slices; scrape a little of the fat of bacon, and put into a sauce-pan, with a little parsley, shallots, and mushrooms chopt very small, adding a little salt and pepper; put them upon a slow fire to fry a little, and place this seasoning upon the cut sides of the gourd slices: put the whole into a quick oven, with a little melted butter or olive oil, and when baked a little, serve up the dish.

To dress Vegetable Marrow.

TAKE the fruit when about half grown, cut it lengthways through the middle, (if large cut into three or four slices), take off the outer-skin, cut in-

to small dice about half through one side of the slices ; then scrape a little of the fat of bacon, and put it into a sauce-pan with a little parsley, shallots, and mushrooms chopt very small, and let them fry a little ; then add about a table-spoonful of flour, with a little salt and pepper mixed all together ; then put the slices of the vegetable marrow into a stew-pan with a cover, and put the fried seasoning over the slices, and let them stew a little on a slow fire, with a little fire on the cover. When enough done, serve up.

The cheese-gourd, when in a growing state, is also dressed in the same way as the vegetable marrow, as in the receipt above given.

When the value of the cheese-gourd is better known, I expect to hear of it being in general cultivation for culinary purposes, for the markets, and in many cottage gardens.

Should you consider the above communication, or any part of it, of sufficient importance to be attended to, you may lay it before the Society. And I am, &c.

XXVIII.

On the Keeping of Apples.*

In a Letter to the Secretary, from Mr WILLIAM OLIVER,
Gardener to the Right Hon. the EARL of ROSSLYN, dated
Dysart House, 31st October 1827.

(*Read 6th March 1828.*)

SIR,

I NOW comply with the request intimated in your letter to me of the 8th June last, although I believe that the method I practise here in preserving

* The Minutes of the General Meeting of the Society, held on 7th June 1827, bear, that "A collection of dessert and baking apples, in the highest state of preservation, was laid before the meeting; and the Committee unanimously agree, that an extra medal be awarded to Mr William Oliver, gardener to the Right Honourable the Earl of Rosslyn, at Dysart House, who produced them, with a request that he would communicate the names of the apples sent, and also a detailed account of his mode of preserving such fruit till this late season of the year." At the General Meeting of 6th March 1828, when Mr Oliver's communication was read, beautiful specimens of 35 kinds of dessert and orchard apples, from the fruit-room at Dysart House, were placed on the table.—P. N. *Sec.*

apples is not peculiar, nor possessed, perhaps, of any superiority to merit the notice of the Society.

My two fruit-rooms are not fitted up in the first style; but I hope to be excused in dropping a few hints, by way of introduction, on fruit-rooms generally;—I think the subject is worthy of attention.

The fruit-room ought to be placed in the most dry, cold, and shady situation that can be conveniently selected. If free from wet, I would prefer the house to be sunk three or four feet in the ground,—but it must be perfectly dry. The size of the room, and number of shelves, will, of course, be regulated by the quantity of fruit to be deposited in it. The shelves should be of hard wood (beech or plane-tree), not of fir, about two feet wide, and ten inches asunder. Last year (1826) I had experience of the bad effect of fir shelving,—the fruit kept on it tasting very much of the wood; whilst, in the same room, the fruit on the hard wood shelves retained all their native individuality of flavour. I see no need for fire being used in fruit-rooms; for I have learned from experience, (there being no fire-place in either of my rooms), that a little frost does not injure apples. The one room is in a situation a good deal exposed to frost, and I have sometimes had the apples in it absolutely frozen; yet even here they kept equally well with those in my other room, which, from being situated lower, has very seldom been affected by frost. There ought to be ventilators in the house,

as a good deal of air is necessary after the fruit is first gathered and stored.

Assuming, then, that the room is well aired, clean, and dry, I shall now detail, in order, my mode of gathering, treating, and preserving the fruit.

When the apples begin to drop freely, ladders of sufficient length to reach the top of the trees are provided ; as also *shallow* baskets for receiving the fruit, and conveying it to the fruit-room. In gathering the apples, the *ripest* only are taken. These are easily known, by raising them to the level of the foot-stalk ; if they part freely from the tree, they are laid carefully in the baskets, one after another, until the baskets be full. They are then conveyed to the fruit-room, and taken *singly* out of the baskets, and placed upon the shelves. The operation of gathering the fruit is repeated every three or four days until the whole is safely lodged in the fruit-room. I never make a *clean sweep* at once, for, when favourable weather occurred, I have known the fruit that was left grow larger, and ripen as thoroughly as the first gathered.

After the apples have been ten or twelve days on the shelves, the process of *sweating* is considered as accomplished. They are then wiped one by one with clean soft cloths ; by this means a kind of *coat* or *shell* is formed, which proves a safeguard to the fruit. The shelves are wiped at same time on both sides until quite dry. During the whole time the

apples are in sweat, plenty of air is admitted, if the weather is clear and dry ; but, if damp, the room is entirely shut up. I think it is when the apples are sweating that they imbibe the flavour of whatever materials they are laid upon ; and, if due attention is given to them at that time, there is little chance of their afterwards acquiring any bad taste.

About the latter end of January another *turn over* is made among the apples. The shelves are again wiped, as is also any of the fruit that appears to be damp. After this time, the room is closely shut up, for I have found that the admission of much air after the end of January occasions the fruit to *shriveled*. The fruit is now handled as little as possible, and only wiped when to be sent to the table.

All the time the fruit is in the room, it is carefully looked over every four or five days, to see whether any be *spoiling*. If there are, they are taken out, and the place they occupied wiped dry with a cloth.

During the remainder of the season, at least until August, the apples are lifted two or three times, and the shelves wiped on both sides until dry. The apples are then laid carefully on the shelves again, care being taken that the hands are dry when handling them, or that gloves be used, which is preferable at that advanced time of the year.

It is to be carefully observed, that, when the apples are frozen, no artificial means must be used to

thaw them; and that, if they are affected by frost or damp, *when in sweat*, they will be materially injured.

I have gathered apples, and laid them upon one another in large baskets in a vinery, kept up to about 60° F., for ten days or a fortnight. They were then covered with sweat. I had them wiped, conveyed to the fruit-room, and laid on the shelves as already described. I have never found the flavour of apples treated in this way to be in the least impaired.

I have tried to keep them in pure dry sand; also wrapped in paper, and packed in close boxes; but have never found any of these methods turn out well.

The names of the varieties of apples presented in June last are annexed.

- | | |
|-----------------------------------|----------------------------------|
| 1. Ganges, from the Wall. | 7. Red Cluster, from a Standard. |
| 2. Nonpareil, do. | 8. Winter Pearmain, do. |
| 3. Newton Pippin, do. | 9. Carlisle Codlin, do. |
| 4. Ribston Pippin, do. | 10. Red Colvile, do. |
| 5. Gogar Pippin, from a Standard. | 11. Yorkshire Green, do. |
| 6. Woolbeding Stone-Pippin, do. | 12. Lord Nelson, do. |

At the General Meeting, 6th December 1827, the Society's Silver Medal was likewise awarded to Mr Oliver, for excellent orchard apples. The following

twelve were selected by Mr Oliver for competition ; and his account of the character of the trees, and quality of the fruits, is here given.

1. *Kirke's Lord Nelson.*

A strong spreading tree, has remarkable short fruit-spurs ;—flower buds reddish and pointed, closely formed round the leading shoots ;—fruit holds well, being short in the stalks ;—the tree bears well.

2. *Kirke's Scarlet Admirable.*

A handsome growing tree,—the leading shoots run rather naked,—fruit-spurs long,—flower-buds flattish and soft. The tree bears well. If the crop is light it is very showy ; but if heavy, the fruit has not such a high colour.

3. *Pile's Russet, or Nonpareil Russet.*

A fine, free, and handsome grower ; a great bearer, and falls soon into bearing ;—spurs shortish,—flower-buds short and flat,—fruit sets free, rather in clusters, resembling the Old Nonpareil ;—is a tenacious holder.

4. *Barcelona Pearmain.*

A strong and upright growing tree,—spurs very short,—flower-buds short, and a little pointed,—closely placed round the leading shoots ;—tree bears well, and fruit holds well.

5. *Woodstock Pippin.*

A strong spreading tree, resembling Kirke's Lord Nelson, only the flower-buds are flatter and lighter ;—spurs are short, and closely placed round the leading shoots.

6. *Potter's Large Apple.*

A spreading tree,—spurs short,—flower-buds rather long and pointed,—bears well.

The above six sorts were grafts from England nine years ago.

7. *Woolbeding Stone-Pippin.*

An upright growing tree, a great bearer, and bears early ;—short spurs, and the flower-buds closely placed round the leading shoots.

8. *Red Cluster.*

A fine tree,—not a strong grower,—long spurs,—flower-buds oval,—bears well,—sets in clusters,—fruit keeps long.

9. *Gogar Pippin.*

Is a great bearer, but does not fall so soon into bearing as the most of those above described ;—sets free, and holds well.

10. *Winter Strawberry.*

A spreading growing tree,—the leading shoots run naked,—fruit-spurs projecting from the leaders,—flower-buds short, smooth, and reddish.

These four sorts are from young trees planted seven years ago, in a soil from twenty-two inches to two feet thick, on a freestone bottom.

11. *Paradise Pippin.*

From an old tree,—bears remarkably well,—flower-buds small, short, and soft.

12. *Grey Leadington.*

Also from an old tree, fruit-spurs short, projecting from the leaders,—flower-buds soft. This does not appear to be an early bearer ; for I have two of the kind that were planted with the first ten sorts, and they do not yet begin to show the least symptoms of bearing. Trees, however, that are about twenty years old bear well. This sort is greatly famed by old horticulturists ; but from the above description, and the sample produced, is it a sort worth waiting on ? or has it not degenerated ?

XXIX.

*On preparing a Light Garden-Soil for Carrots
and for Onions.*

In a Letter to the Secretary from Mr PETER CAMPBELL,
Gardener to JAMES HAMILTON, Esq. of Bangour, at
Coalston, near Haddington.

(*Read 6th March 1828.*)

SIR,

I NOW communicate to you my mode of preparing a light sandy soil for carrots and onions, founded upon experience, which I hope you will have the goodness to read to the meeting of the Caledonian Horticultural Society 6th December.

Carrots.—The first year that I came to Coalston, (1823), having got notice that there had been no carrots raised in the garden for ten years back that was worth taking notice of, owing to the soil not suiting that crop, I thought to prepare the soil for carrots by trenching a plot of ground to the depth of twenty inches. Thus I thought that I would be sure of a good crop of carrots, the ground not having been trenched for a number of years back.

Carrots sown on the said trenched ground in the beginning of April, produced a very fine braird, and did well till about the middle of July, when they were seized by small white maggots or worms, which infested the whole crop of carrots, and cut them almost all off together. Although I tried soap-suds, with potass mixed in it, likewise salt water, and water mixed with soot, none of these proved of any effect.

In 1824, I thought it proper to sow carrots in part of three different plots, but they were all destroyed by the foresaid vermin. They pierce the carrots into the heart, and immediately the branches or tops drop to the ground: if the plants survive, the roots form into fingers-and-toes, (as in the disease called *anbury* in turnips), and are good for nothing. I tried quick-lime water upon these different plots, by putting lime-shells in water until they were dissolved; but this had no good effect. I now had recourse to another plan. In autumn I made up a compost of turf, taken off a sheep pasture, which had lain in grass for about twenty years; taking care to take it off the places where the sheep lay most upon. I mixed this with lime-shells, in the proportion of two cart-loads of lime to six of turf. I trenched the plot I intended for carrots, in 1825, to the depth of eighteen inches in February; and about the end of March I got the ground compounded with the foresaid compost, at the rate of eighty cart-loads per acre, as near as I could calcu-

late. With this management I have had as good crops of carrots for these three seasons past as could be wished for, and free of any insect. The compost may be easily obtained, by feeding sheep upon a small plot of ground with turnips

It may, perhaps, be agreeable to the Society that I should here mention my mode of storing and preserving carrots.—I generally make it my study to have up my crop of carrots about the middle of October, if the weather is dry; for carrots ought not to be taken up in damp weather; as, if they are laid up damp, they are very ready to melt away like soap. I cut off about half an inch of the carrots along with the tops, so as to prevent them from springing; as, when they spring, it takes away both the substance and flavour of the carrots. I dig out a pit, to the size I want, about a foot below the surface of the ground, then build the carrots neatly up in the form of a cone, with the top ends out, without mixing any sand amongst them, or even straw on the outside of them, but covering the pit with earth, to the depth of twelve or fourteen inches. In spring 1818, I tried how long I could keep carrots in this way: I took two dozen of the preserved carrots of crop 1817, and placed them in a pit two feet below the surface of the ground, and covered them. They were found perfectly good in March 1819; they were, indeed, grown about two inches longer in the small ends of the carrots, but very tender and fine-flavoured; there was not the least appearance of any tops.

Onions.—I likewise communicate to you my mode of preparing a similar soil for onions. In 1823 I lost most part of my crop of onions by the maggots, and a rot or rust that they were seized with. Light soils are very much infested with this rust, and it attacks particularly spring sown onions. The method I used for preserving my crop, both from the maggot and rot, or rust, was this: I made up both the sides of the onion beds, so as to prevent the water from running out upon the paths or alleys; and having made up a very strong dose of quicklime water, with the shells dissolved or mixed down in the water, with this I watered the beds to that degree that the lime lay one-eighth part of an inch upon the beds. This saved all those that was not overrun, and destroyed all the maggots. In 1824, I made up a compost of turf of a sheep pasture, taking it off the places where the sheep lay most upon; likewise lime-shells, and pigeon-dung, and bog-earth. The proportions in making up the compost are: Two cart-loads of lime-shells to four of turf; one of pigeon-dung to two of bog-earth. I compounded the ground with it at the rate of seventy-five cart-loads per acre. Since I have used this compost, I have never seen a maggot amongst the onions, nor has one out of 500 been seized with the rot or rust.

COALSTON, }
 12th November 1827. }

XXX.

*On the Upright Training of Garden Rose-bushes,
and of the Cydonia Japonica.*

In a Letter from Mr JOHN DICK, Gardener at Ballindean,
to the Secretary.

(*Read 6th March 1828.*)

DEAR SIR,

I BEG to trouble you with a few remarks upon the training of garden rose-trees, and also that beautiful plant the *Cydonia Japonica*.

I. With respect to garden rose-trees.

The rose-tree is a very fine plant, when it is in blossom, and its admirers are very numerous. Rose plants have been trained various ways. Some are fond of them kept hooked down to the ground. By this method of training, the blossom is soon over, and the roses are very often destroyed by the earth being thrown up upon the flowers, after a heavy shower of rain; and sometimes the flower-petals are soon injured by the sun-beams in dry hot weather. I do not wish to depreciate any other person's ideas or his

mode of training roses, but shall merely mention what I have found, upon trial, to answer best in the situation where I am placed.

After the rose-bushes are planted, and have stood for a year, I prune or cut them well down, which causes them to push out strong shoots. I then make choice of a strong shoot which is situated near the centre of the bush. I tie it up to a stake; it will sometimes grow four and sometimes five feet high in a season, more or less, just as the plant is in strength. When I get the shoot as high in one year as I want it, I then stop its growth at the top. I keep it always fast to the stake. At next winter's pruning, the bottom part of the bush is well cut down. This throws a deal of strength into the straight stem which is trained to the stake, and at the same time makes the bottom part of the bush throw out fine roses. There will some wood-buds break out upon the straight stem: I rub these nearly all off, leaving only about four or five wood-buds at the top of the shoot, in order to remain and form branches there, where they will throw out very fine roses. These top branches remain to form the permanent head of the rose-tree. When the top shoot, and the bottom part of the bush are both in full blossom, the whole makes a very fine appearance. Year after year, the upright shoot gets more strength, and becomes like a rose-tree, which in reality it is. The same simple mode of training is continued year after year with very little trouble. I

find that rose-bushes throw out larger and finer flowers, by the above method of training, than any other that I have seen ; and the above method of training is within the reach of the humble cottager, as well as the highest nobleman. I may add that experience has taught me that it affords a longer continuance of flowers for the season upon tall stems, than when the common mode of budding garden roses upon transplanted wild roses, or briar shoots, is resorted to. When a quantity of rose-bushes so trained, are planted upon a sloping bank, in form like an amphitheatre, they have a very splendid appearance to the eye, when in flower. The above method is practised upon a bank at Ballindean, where there are 130 kinds of roses, and the effect is excellent. The moss rose, white Provence rose, Tuscany rose, and all the strong growing roses, are thus managed easily, and make fine plants in a short time. The Scots roses (*Rosa spinosissima*) make fine plants also, but it takes a year longer to get the stems up to the height wanted, their growth being slow and naturally humble. Any kind of garden roses can be budded upon the top of the upright stems, just as any person fancies to have different colours put together. One great advantage is, that the buds are not so readily broken off as when placed upon a briar or wild rose stock.

Those putting the above method of training rose-trees into practice, will find the effect of it fully to their mind in the end.

II. I shall now lay before you the mode I have practised for training the *Cydonia Japonica*, for the last six years.

The *Cydonia Japonica* is a plant which has a natural tendency to grow in a straggling manner, which led me to contrive a mode of training, in order to get the plant trained up to a straight stem and regular appearance.

When I get the plants from the nursery, or rather when I have struck them from cuttings, which is easily done, I plant them in flower-pots suited to the size of the roots. As soon as they begin to grow, and send up a straight stem, I train the stem up to a perpendicular stake. As the stem advances in height, I rub off the greater part of the buds from it, leaving only two or three at the top. This greatly strengthens the stem, and prevents any branches appearing about the bottom of the plant. The same method is continued year after year. When the plants need shifting that must of course be attended to. The plants will soon form fine strong stems. They may then be planted out in the open border, in good aspects and situations. Then the small buds for the flowers will begin to show themselves; and the branches when they are wanted, must now be let come out, and they also will soon show plenty of flowers. The plants continue a long time in blossom. If a few of the plants be kept in flower-pots, they will, after getting moderately strong, have a splendid appear-

ance in a green-house. I do not need to say any thing about training them against walls, as that is easily done. I have them at Ballindean against walls very beautiful plants; and also trained upon fine wire railing, in front of Ballindean House, where the flowers are exceedingly rich. I give the above notice that any gentleman may try these plants trained upon an open railing of wood or wire without a wall. I think they will flower magnificently.

I have no doubt but William Trotter, Esq. of Ballindean will avouch for the correctness of what I have stated in this paper, and any member of the Society travelling this way may see the practice here. I am, &c.

BALLINDEAN, }
3d March 1828. }

XXXI.

*Account of Oiled Paper Frames for protecting
the Blossom of Wall-Trees.*

In Letters from MR ALEXANDER SMITH, Gardener to
THOMAS BRUCE, Esq. at Grangemuir, to the Secretaries.

To MR T. DICKSON.

(Read 17th September 1816.)

SIR,

I BEG leave to send to you, for the information of the Caledonian Horticultural Society, an account of the construction of oiled paper frames, for protecting fruit blossoms upon wall-trees, used by me at this place for the last four years, with good success.

These frames may be made of any convenient size to answer the height of the wall. Those used by me are five feet by three; the thickness of the wood inch and half square, having five cross bars mortised into the sides. Further to support the paper, each frame is wrought with strong pack thread, about nine inches square; and the pack-

thread is fixed with white tacks. The frame thus constructed is covered with coarse writing paper, pasted to the wood and pack-thread with well made paste. The paper should not be drawn very tight when first put on, as it is apt to crack in hot sunshine. When the paste is perfectly dry, a coating of boiled linseed oil is laid on both sides of the paper with a paint brush.

These frames, when first finished, cost 3s. Sterling each.

Various modes may be adopted for fixing the frames against the wall, but as yet our trees at Grangemuir do not fill the wall, and the following mode has been adopted.

Temporary rafters are placed in the ground four inches deep, and two feet from the wall; the top of the rafter leaning against it, is fixed with a strong nail. For the purpose of securing the frames to the rafters, small pieces of wood, four inches long, are nailed across each rafter, but sufficiently distant to admit, with ease, the sides of the frame between the piece of wood and the rafter, so as the frame may slip up and down as wanted; which, with a nail slightly drove at the lower corners, keeps them perfectly secure, while it admits of their being moved at pleasure. I have got made also six triangular frames to fit the spaces at the sides of the trees so covered, between the wall and front frames, which prevents much cold air from reaching the blossoms.

The number of frames here is twenty-two, which, at
 five feet by three, is = 330 } square feet.
 Side frames, - 42 }

 372 in whole.

I have never applied these frames till the blossoms were pretty well out ; and can safely say, that, for the purpose of protecting the flowers and fruit from the effects of spring frosts and hail showers, I have found them to answer well. The garden here is new, without any natural protection, and the trees planted for this purpose, or as screens, are only now getting above the walls ; nevertheless, for the last three years, our peaches have ripened well, and proved of a most excellent flavour.

Care must be taken to keep the frames from vermin, particularly mice. Likewise they must be handled with care. All the repair they need is trifling ; and I do it myself, at times when out-door work cannot be done.

Having stated these general remarks, I shall trouble you only with two particulars, which may be worthy of notice. 1st, Adjoining each other there are two green-gage plums : the first two years of using the frames they were applied to one of these trees, while the other was left to its fate. The covered tree produced two-thirds more fruit, which was finer, one-third larger, and likewise earlier. Last year and this I covered the other tree,

leaving the former to chance; the result was, that the uncovered tree last year had twenty plums, while the covered tree had a good crop. This year the difference is equally great, which may be seen by any one who may choose to inspect the trees.

2d, The other remark is upon a peach-tree, which, for the last three years, (from the advantage of these frames,) had always a fine crop, and this season the appearance of the same; but one part of the tree was, this year, left to its fate, while the other part was covered as usual. The fruit set well on the whole tree; but when they took their first swelling, the fruit on the part of the tree which was uncovered, all dropt off, while on the part covered a good crop remains.

GRANGEMUIR, }
 Aug. 29. 1816. }

TO MR NEILL.

(*Read 2d September 1819.*)

SIR,

THE Caledonian Horticultural Society, in the year 1816, requested information concerning frames covered with oil paper, used for preserving the blossom of fruit trees from spring frosts. According to the advertisement in that year, I sent a description of the frames used in the garden at Grangemuir with good effect. As I have had three years more experience of them, I again take leave to inform the

Society, that, among all the different methods used here for preserving blossom, these frames have given the most satisfaction. The trees they were applied on this season, are two peaches, each of them bearing a full crop; one apricot, and a green-gage plum; each of these promising also a very tolerable crop. I may here notice, that a green-gage stands next to the one covered with the paper frame: it had a great show of fine blossom, from which I expected a crop without protection, but the great appearance has dwindled away to a few stunted plums, while its next neighbour has, as already mentioned, a very tolerable crop, thus affording a proof of the good effects of the frames. As formerly mentioned, the size of the frames is three feet by five: they are made of inch and half plank, with cross bars, all mortised; this is wrought on one side with good pack-thread about nine inches square, the pack-thread being fixed with small tacks; after this the whole is covered over with coarse writing paper, which is made fast to the frame and twine with good paste; and when all is fairly dry, a coat of linseed oil is laid over the whole with a small brush. It was found, by experience in the repairing, that a narrow slip of paper, pasted over the twine to the paper on the other side, is a good support. Likewise, that if one ounce of fine white lead be well mixed in a pint of oil before using, it makes the paper more durable, and gives it more transparency.

In applying the frames, a temporary rafter is made

fast at the top, with a nail driven into the wall, and the end of the rafter is sunk four inches in the ground two feet from the wall. The frames are kept fast at the upper end by a piece of wood four inches long and one inch square, being nailed crossways on each rafter, leaving space for the frame to slip up or down as may be wanted. This, with a double nail at each corner below, keeps them quite firm. For keeping off the cold air, where the frames terminate, I have six of triangular form: their size is seven feet long by two at the base; one edge of these is fixed to the wall, and the other to the outmost rafter. The expence of keeping these frames in repair on an average is three shillings per year for oil and paper, and the repairs are done in bad weather when other work is stopt.

GRANGEMUIR, }
Aug. 28. 1819. }

At a meeting of the Society, 2d December 1819, the silver medal was awarded to Mr Alexander Smith for the introduction of these oiled paper frames, for protecting the blossom of wall trees from spring frosts.

P. N. Sec.

XXXII.

Notice of an Improved Mode of Glazing Hot-House Sashes.

In a Letter from JOHN ROBISON, Esq. to the Secretary.

(*Read 7th June 1827.*)

DEAR SIR,

I BEG leave to submit, through you, to the Horticultural Society, a mode of glazing hot-house sashes, which appears to me to possess some advantages over any which I have yet noticed.

The object of the proposed mode of cutting the glass is to prevent, as far as possible, the lodging of water in the overlaps; and for this purpose I would suggest, that, instead of forming the panes into rectangles, as is usually done, they should be cut obliquely, as in Fig. 1. in the accompanying sketch, Plate VI; by this means the water would be induced to run towards the bars, and would then be conducted by them to run off at the lower edge of the sash.

I am aware that another plan has been partially adopted for this purpose, viz. by cutting the panes with convex and concave curved ends, such panes being sometimes fastened in the sashes as at Fig. 2,

Fig. 1

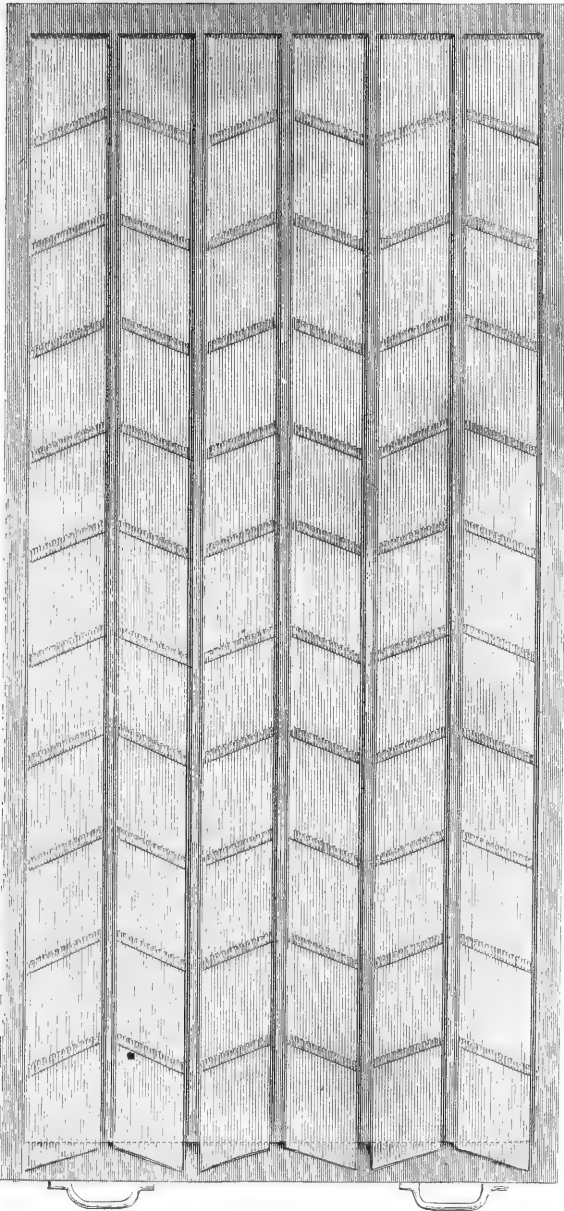

Fig. 2

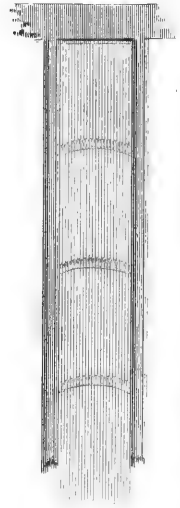
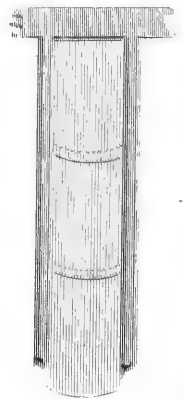
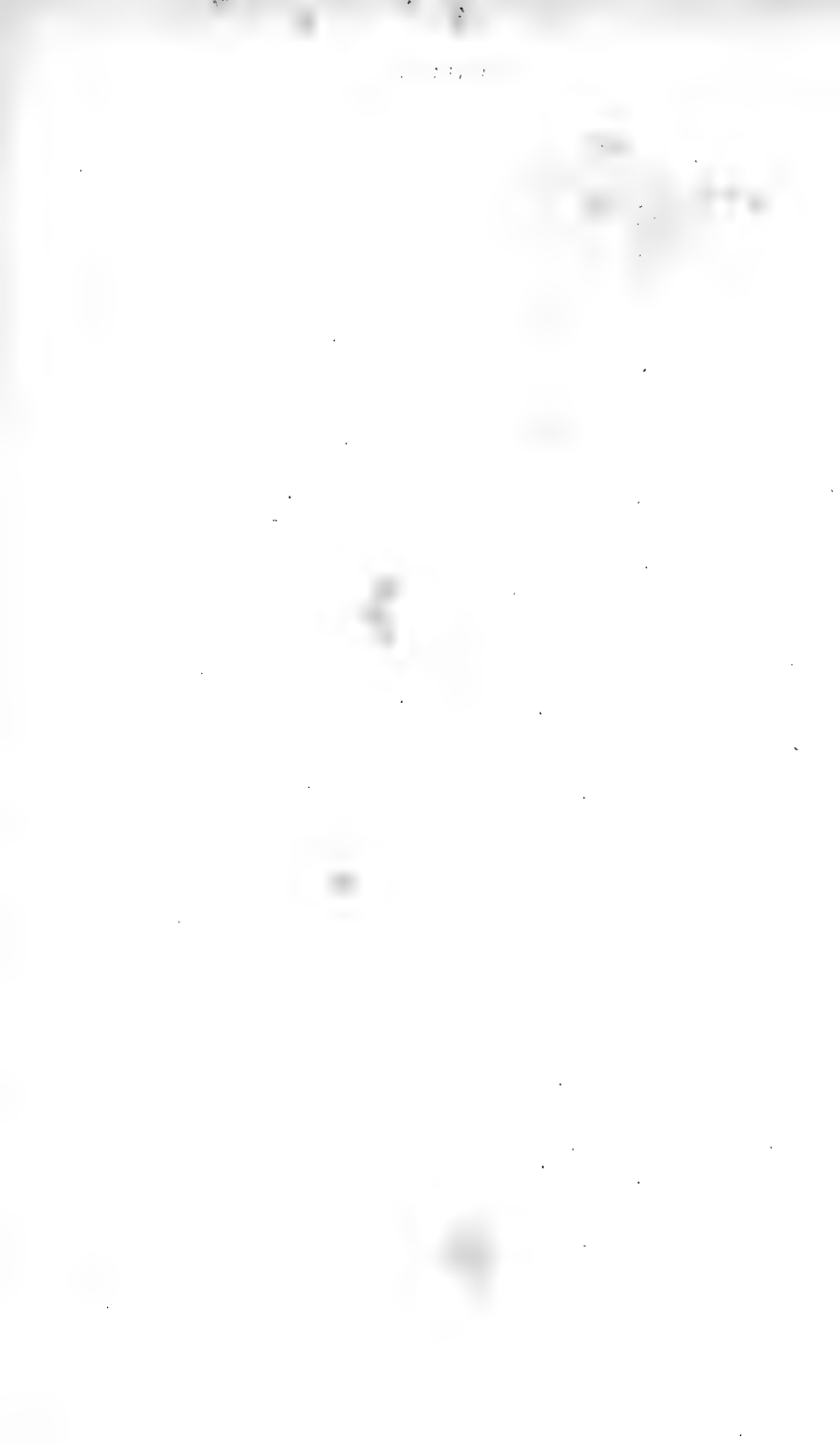

Fig. 3





but more generally as at Fig. 3. (of which Fig. 2. seems to answer best in practice, see Plate VI.) The cutting of glass in this way is troublesome and expensive, when the curve is made quick enough to have any considerable effect in leading the water off; while any useful degree of obliquity may be given to the panes on the plan Fig. 1, without at all increasing either the difficulty or expence. I am, &c.

9. ATHOLL CRESCENT, }
7th March 1827. }

XXXIII.

*Account of Steam-Pits for the culture of Melons,
at Rockville, in East Lothian.*

In a Letter to the Secretary, from Mr PETER DEWAR,
Gardener at Rockville, dated 4th September 1827.

(Read 6th September 1827.)

As I have not heard of any communication having been made to you, of steam being applied to the growth of melons, I have sent you a rough drawing of two pits, with steam apparatus, at Rockville. They have been used for two seasons, and I have found them to answer remarkably well. Each pit is 21 feet within, and 22 feet over all in length; and 6 feet within, and 7 feet over all in width. I have never had it in my power to try steam with very early forcing: last year it was the 18th of June before I got the apparatus fitted up to try the experiment with one of the pits, the pits having been previously built, one of them for fire-heat, dung, or bark, the other for fermenting substances only. Having found it to answer, I had the boiler placed in the centre of the two pits this season, and wrought

them both with it. I am now convinced that, by steam, the heat can be kept better up, and more steady, than with dung; for it frequently happens, where dung or short grass are scarce, that the crop is almost lost before a sufficient quantity of stuff can be collected to make linings; whereas with steam I can raise the heat to any degree I wish in a few hours. The method I have adopted, is to lay the pipes two feet below the surface of the mould in the bed. The pipes are readily got at any pottery, being the same as those used to convey water under ground, and of 3 inch bore. They are bedded in sand; then covered with a foot of bark, or tree-leaves, and a foot of mould. I introduce two or three watch-sticks quite through the mould. Having turned on the steam, when I feel the points of the sticks getting a little warm, I judge that the heat is sufficient, and turn off the steam.

It was suggested to me to make a vacuity or chamber all under the mould, and to fill the whole with steam; but I did not approve of this, as it would require a boiler of more power, and it would be more expensive to keep up the steam in a large boiler. It farther appeared to me, that the heat would not be so regular as when confined in pipes, as the steam would be nearly all condensed before it could reach the opposite ends of the pits.

The flue is carried through below the surface of the walk that goes round the pits, and runs back about 12 feet, where the stack of the chimney is

carried up amongst some bushes, on purpose to conceal it as much as possible.

It was the 8th of May this season before I got the plants put out; and, on that account, I have not found it necessary to use the steam oftener than once a week.

I have sent you a specimen of the fruit thus produced with steam*. I have cut some larger than the melon sent.

I think such a steam-pit would be good for pineapple plants.

If you judge the above worth laying before the gentlemen at the meeting, I shall be truly happy if I have contributed any thing to the advancement of horticultural science.

April 1828.

Since I wrote you last September, I have had a winter as well as summer's trial by the steam; and I think that every thing may be expected from it where bottom heat is wanted.

I have added a course of pipes along the back and front of the pits, on the surface of the mould, as, in very cold nights, even although I had a good bottom heat, I felt the surface cold. But the surface-pipes have entirely removed this evil: it is only in very cold weather that they are wanted. I

* It was a canteloupe melon, and of good size and excellent flavour.

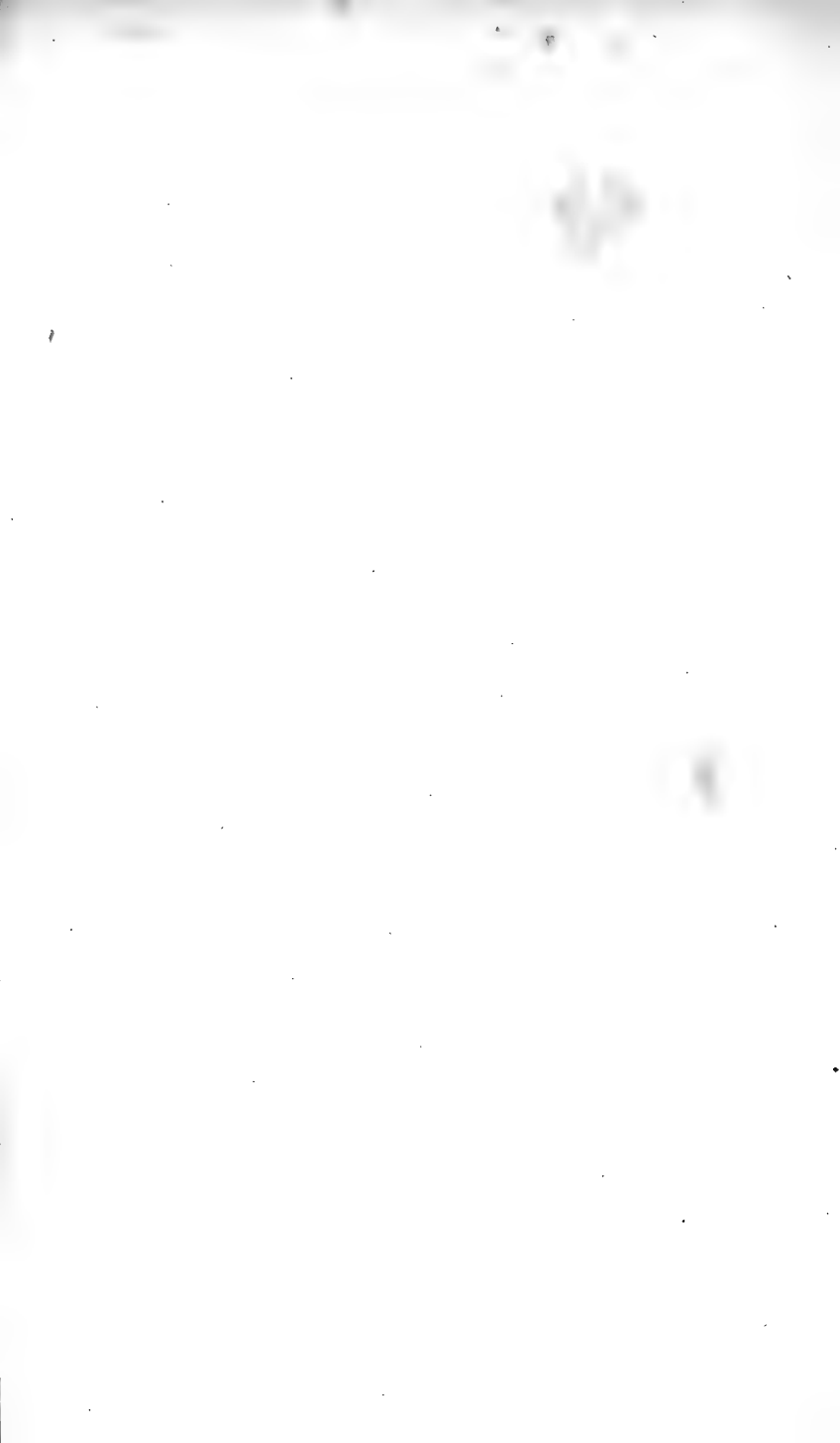

M. Dewar's Steam Fits.

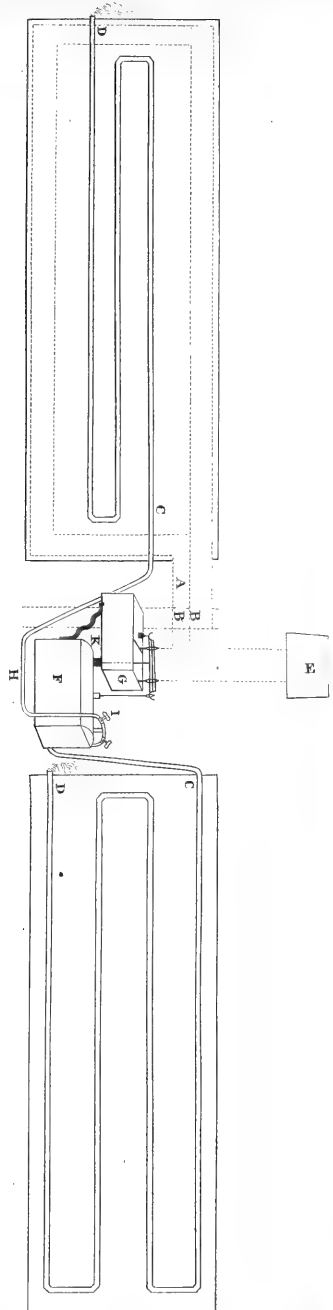
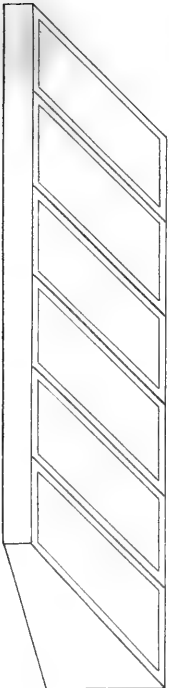
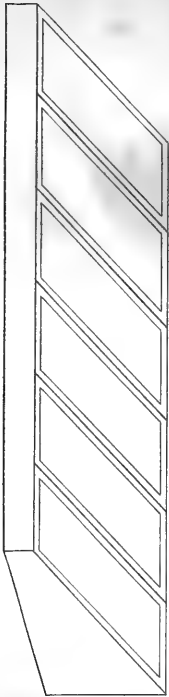

find that the steam will go the round of the surface pipes in about 15 or 20 minutes, which is quite enough to keep every thing in the pits comfortably warm through the night.

I am now perfectly convinced, although I have had no practice, that steam applied in the same way for bottom heat to pine-apple plants, would answer well; even setting aside the saving of time and material; for, whatever is found most convenient for plunging the pots in, would last for some years, as it would require no turning, except to the depth of the pots at the time of plunging.

General Dalrymple, North Berwick, has got two pits fitted up with a steaming apparatus, on the same plan as those at Rockville. These pits are giving great satisfaction, and going on with every appearance of success.

Explanation of Plate VII.

- A, a fire-flue, wrought at pleasure by a damper at
 B, by the fire from the boiler.
 C, D, Earthen pipes of 3 inch bore, for conducting the steam under the mould in the pits.
 E, The vent or chimney.
 F, The boiler.
 G, The cistern for supplying the boiler with water. The boiler is 3 feet long, 1 foot 6 inches wide, and 1 foot 9 inches deep. The cistern is 2 feet long, 1 foot 6 inches wide, and 1 foot 2 inches deep.
 H, A lead pipe for conveying the steam to the earthen pipes, $1\frac{1}{4}$ inch bore.
 I, A stop-cock.
 K, A valve for filling the boiler with water.

XXXIV.

*Notice regarding the Ionian Melon and the
Malta Melon.*

In a Letter to the Secretary from Mr DANIEL CRICHTON,
Gardener to the Right Hon. the EARL of MINTO.

(Read 2d August 1827.)

SIR,

I DEFERRED answering your inquiries about the Ionian and Malta Melons, until I should have an opportunity of seeing the Honourable George Elliot, Captain of His Majesty's ship Victory, who sent the seed to me by the Right Honourable the Dowager Countess of Minto. Understanding, however, that he is not expected at Minto soon, your inquiries were forwarded to Portsmouth, and I now give you the substance of the Honourable Captain's answer.

He mentions, that, when about to leave the station at Malta in the year 1804, he procured a quan-

tity of the best melons he could find, as sea-store, and bought them as the farmers or gardeners from the interior were carrying them into the market at the city or fort. There were two sorts; one of a longer oval shape than the other, or one oval and another nearly round. Both proved of excellent quality. The roundish sort were called "Winter Melons," and were particularly remarkable for keeping long: they proved good even in England, after a tedious passage from the Mediterranean, and after a six weeks quarantine before they could be landed. Both sorts are common in Malta, where the Captain thinks the best fruit in the world is to be found.

It was in February 1805 that I received the two sorts of melon seeds that the Captain alludes to in his letter; the one marked "Excellent Green Melon," and the other marked "Keeping or Winter Melon." Both parcels were wrapped in a piece of paper, on which was something about the *Ionian Islands and Malta*, and, to distinguish them from the other melons I then cultivated, I called one the *Ionian*, and the other the *Malta* melon. Such is the origin of these names. But you will observe, by the Honourable Captain Elliot's letter, that both kinds came from Malta, where they were brought from the interior to market. I have now cultivated both varieties for upwards of twenty years.

Of the one generally called the *Ionian Green-fleshed Melon*, I sent a specimen to the Cale-

donian Horticultural Society a number of years ago, when it was justly appreciated by the Society*. It was the melon the Captain alludes to as more oval-shaped. It has a very thin skin, often a little netted; and, when well ripened, is more of a lemon colour than a green. It seems to delight in a moist high temperature; weighs from two to five and six pounds, according to the season, strength of the bed, mould, &c. As I stated before, I grow them chiefly on beds made of stable-dung and leaves; made up in the ordinary way,—the strength of the beds to suit the time of the season they are made in. I have the first crop ripe, generally in the end of May and beginning of June. I consider it an excellent melon, and good bearer, either early or late in the season.

The other sort, commonly called the *Malta Melon*, is also an excellent fruit, either for summer use, or for keeping: if grown late in the season, and cut before it is too ripe on the plant, it will keep many weeks. It is a round melon, the flesh more of an orange colour than the former, and high flavoured; the skin hard, and a little netted; weighs about three or four pounds, and is a good bearer. This is

* On 1st July 1819 the Society's Medal was voted to Mr Crichton, for having introduced into this country the culture of the Early Green-fleshed Ionian Melon.—See also communication by Mr Howison of Crossburn House, Hort. Mem. vol. iii. p. 209, *et. seq.*—P. N. Sec.

the one the Captain alludes to, as the keeping or winter melon.

I have only to add, that I consider these as two excellent sorts of melons ; indeed, they are almost the only kinds I now cultivate, the family likes them so much. I considered them, when I cultivated them first in 1805, new kinds, but, since then, I have given and sent seeds of them to many places of the United Kingdom. Others as well as the Honourable Captain Elliot may have imported seeds of these melons, and others may have cultivated them before 1805, in this country ; but I can say, that, before that period, I never did see or hear of any of their habit of growth and excellence of quality of fruit.

MINTO GARDEN, }
June 26. 1827. }

XXXV.

Notice regarding the Cause of Canker, the Natural History of the Red Spider, &c.

In a Letter to the Secretary from Mr WILLIAM BLAIR,
Gardener at Mount Stuart.

(*Read 1st March 1827.*)

SIR,

THE *Canker*, as it is called, and the *Red Spider*, or *Acarus*, are evils which prevail most mischievously in this west part of Scotland. The canker is best known in its effects; but it would be of great moment, if the cause could be understood and removed. It appears to me that it arises from an unfitness in both soil and climate. It is granted by most, that it prevails more of late years than formerly; and the reason may be thus explained. General improvement of land is carried so far now, that the idea has seized many that the most sterile and useless pieces of land may be renovated and fertilized; and from acting upon this principle, how many gardens do we not see placed on the most unfavourable spots of ground, the con-

venience of its situation being the only thing it can boast of? Now, although such gardens are furnished with forced soil to any depth, and trees made to grow to a superfluous luxuriance by the application of manure, still there is a want of fertility or richness necessary to health and fruitfulness, arising from a bad subsoil, united with a tainted atmosphere; for, I consider that the unfriendly nature of the subsoil incorporates itself with the new soil, and sends its vapours through it into the immediate atmosphere of the spot. Probably damps and vapours, arising from waste lands, and moors and morasses lying contiguous, are carried over the whole improved land. We know from experience, that, in the animal economy, bad air is more pernicious to life or health than the unwholesomeness of any other requisite of life; and I believe it is not good for fruit-trees. Trees planted in such situations are made to grow only by the constant application of manure, and never attain that vigour or consistency which they display in better soils. It perhaps may never be ascertained how the roots of trees receive immediate injury from the soil; but it is beyond dispute, that the atmosphere has its nature influenced by the surface which it covers. The best way, therefore, to prevent the canker, so much complained of, is, in my opinion, to form gardens only on naturally fertile soils. Where that cannot be done, the surrounding lands should previously be well drained and improved.

The red spider is generally found in warm sheltered places. Those trees placed against walls are their favourite abodes; it is there, or under the more genial cover of hot-houses, we find them. The cocci, or scales, as they are called, have long been considered a separate tribe of perfect insects; but I rather think they are but the winter cover of the embryo spider, and the different kinds of scale arise, I think, from being the cover of different species of spider. I think there are several species of them common to the plantations of forest-trees. Young ash is much infested with them, and some kinds of willow. These, in the summer months, run everywhere. I once was struck with the appearance they made on an orange tree, which I had under my eye when they were flitting from their little habitations: the tree was very bad with scale, and they came out so thick, that some parts of the wood were covered with them. Some of their habitations I found empty; in some I found them just coming out, where the one side was opened. At Kew Gardens I observed a large kind of coccus, about the size of a pepper-corn, on the vines, which produced a vast number of spider.

At Possil, where I had the charge of the forcing, some of the peach-trees were in a ruinous state the first summer I was there, with scale and spider; and though I applied the syringe three times a-week, it had no effect: but, through the course of the winter, I scraped off all the scale with the back of my knife, and then painted the bark of the stems and branches

wholly over with a mixture of tobacco liquor, sulphur, and a little turpentine, which cleaned them so effectually, that not a scale or spider appeared next season, although no water was applied, but merely to moisten the foliage. The trees made excellent wood. I cannot say how they did after I left the place, but it appeared to me, that cleaning off the scale in winter was the effectual way of getting rid of the spider.

MOUNT STUART, ROTHESAY, }
12th February 1827. }

XXXVI.

Notice regarding Indian Saws.

In a Letter from JOHN ROBISON, Esq. to the Secretary.

(*Read 11th November 1824.*)

DEAR SIR,

IN compliance with your request, I send you a sketch of the Indian saws, which appear well adapted for pruning fruit-trees, or cutting green wood of any kind. You will perceive that their sole advantage consists in their operating by a pull, instead of by a push; as, in this way, if they have stiffness enough to carry them through the wood while not cutting, there can be no possibility of bending or breaking them during the cutting stroke.

Fig. 2. Plate VIII. is a blade four inches broad and eighteen inches long, fixed to a pole-handle of any required length; the line of the teeth should be inclined a few degrees from the line of the pole, to allow of the saw cutting easily without any pressure on the handle.

N: B. The softer the wood is which is to be cut, the less should be the degree of inclination.

Fig. 1

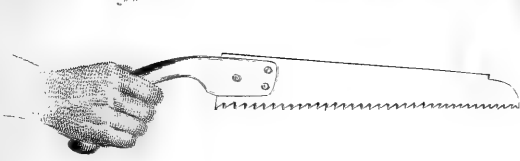

Fig. 2

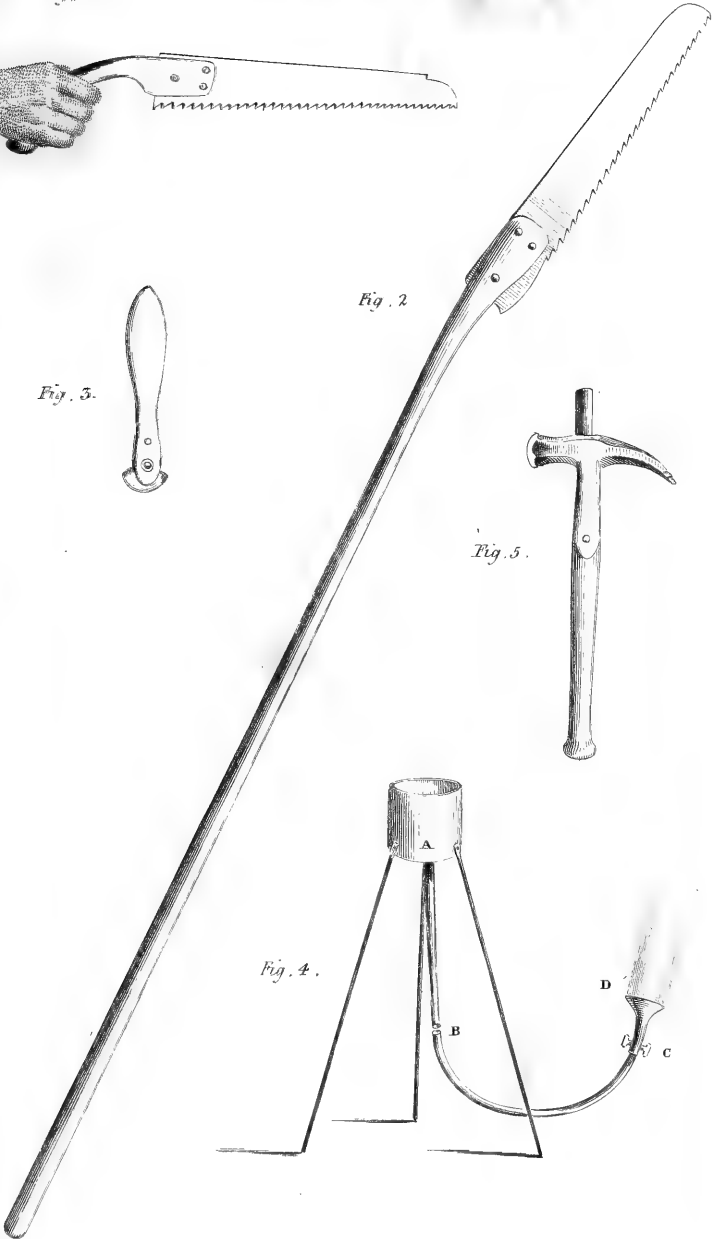

Fig. 3



Fig. 5

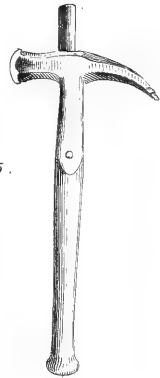

Fig. 4

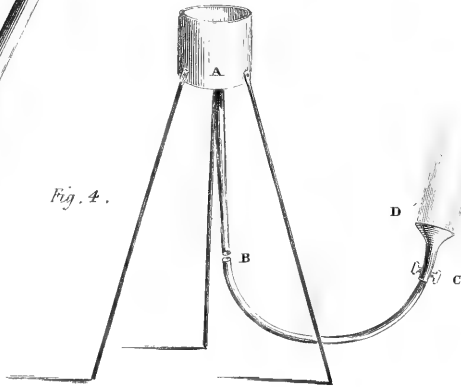

Fig. 1. Plate VIII, a hand-saw, of the same size as the other ; the gripe should be such as to bring the fore-finger and thumb of the right hand nearly in the line of the teeth.

I have found a small saw of this kind about three-fourths of an inch broad and six inches long, (with the teeth rather distant, but very shallow), exceedingly useful in cutting out branches and stumps from trees nailed to walls, as, from its narrowness, it can be applied between the wood and the wall. I am, &c.

16. COATES CRESCENT, }
25th Oct. 1824. }

XXXVII.

*On the Utility of gathering Unripe Tomatoes,
and maturing them on Shelves in Hot-houses.*

By Mr W. McMURTRIE, Gardener to the Right Honourable Lord ANSON, Shugborough Gardens. In a Letter to the Secretary.

(Read 5th April 1827.)

SIR,

HAVING observed in one of the late numbers of The Gardener's Magazine, a quotation from the Caledonian Horticultural Society's proceedings, respecting the Tomato; and not having had an opportunity of seeing the publication alluded to, to know whether the culture of it is such as I have practised myself with great success these ten years past, I am induced to send you a short account of my method, which I think, if not generally known, may be of some service to those who cultivate the tomato in your more severe climate.

It would be superfluous to give a particular account of the first stages of rearing it, these being known

to almost every gardener. I shall therefore proceed to state briefly, that, in March, I sow the seeds in a slight hot-bed; and, when the plants are fit, I prick them out in large pots, for a short time, to acquire strength. I then plant two in a 32 pot; and, in June, turn them out, with the balls entire, against a south wall, previously preparing a spadeful or two of rich vegetable mould to place them in, giving a little water to settle the roots, &c.—all which is the practice of most gardeners.

When the plants arrive to the height of two or three feet, I stop them, by pinching off the tops, having found that the fruit is much finer, and even more prolific, by so doing, than by permitting them to grow higher.

I now come to the object I have principally in view in this communication. In Staffordshire, we find great difficulty in getting the fruit to ripen on the walls, and of course in Scotland it will be more so. By the method which I have practised with never-failing success these many years, it is a matter of complete indifference to me whether the fruit is ripened or not, provided it is swelled to a pretty good size.

About the 20th of October, I generally cut the first gathering, taking all that may have ripened, and the best swelled green fruit. The latter I place in a stove or hot-house, either on a shelf or hung upon a string (having taken care, in cutting them, to leave part of the stem attached for that purpose.)

In three weeks or a month they ripen as well, acquire as fine a colour, and are as good in every respect, as if they had come to maturity out of doors. By the end of October, I make a second gathering, which is generally as late as we can expect with safety, the frost setting in mostly about that time, and I treat them in the same manner as described above. Those who have not the convenience of a stove or hot-house to ripen them in, will find that hanging them up in a warm kitchen or room will, in a great measure, answer the same purpose.

The annual consumption in this family is about two bushels. I turn out about 40 pots (80 plants), which I find is generally sufficient for the supply. Until I practised the above method, I had great difficulty in furnishing half the quantity required, even in the most favourable seasons.

It is possible that this method may not be new to you, or that you may not think the article of sufficient importance to insert it entire. If so, you are welcome to curtail, as I have no other object than a desire to contribute my mite to the general stock of information in your valuable Transactions.

SHUGBOROUGH GARDENS, }
3d March 1827. }

XXXVIII.

On Budding the Peach upon the Apricot.

In a Letter from Mr W. McMURTRIE to the Secretary.

(Read 5th April 1827.)

SIR,

IF you think the following plan of budding the peach upon the apricot will be serviceable to the members of your Society, I shall be very happy in having contributed it. I think that it might be practised with good effect in Scotland, where the severity of the climate almost precludes any hope of cultivating the peach-tree out of doors with regular success. Indeed, I believe it is seldom attempted except upon flued walls. The apricot, however, I am aware, succeeds very well in some situations, and I therefore would strongly recommend to gardeners to insert a few peach-buds into those trees. We are often, even in Staffordshire, liable to have peach-blossom destroyed by the easterly winds, (although de-

fended by canvas in the usual way), which set in very generally in April and May. These winds seldom depart without leaving in their train that destructive insect the aphis or green fly, which frequently destroys the hopes of the gardener.

From repeated visitations of this kind upon my peach walls, it occurred to me to try the peach upon the apricot trees, (which, at Shugborough, are all of the Moorpark kind), and I am glad to state, that the expedient seems to answer my fullest expectations. In 1824, I inserted a quantity of buds, which took readily, and the next season made fine strong healthy wood, and, in 1826, produced fruit far superior to that on the peach trees. I am not prepared to say from what cause; I only speak to the fact; and it is evident, at all events, that they agree well together. The young wood looks uncommonly well now, more vigorous and likely than that on the peach trees; and I form the highest hopes from its appearance. In consequence of the successful result of the experiment, I budded more extensively last season. I prefer budding upon the young wood of the same year, as I find that the buds take more freely, and the wound heals over sooner than if the operation were performed upon older wood.

At the same time (1824), I put in a quantity of nectarine buds upon my plum trees, on a west aspect, considering the nectarine of a hardier nature; but they did not succeed well: they took well enough,

but the wood they made was weak and unkind ; so I have not attempted it again. As the nectarine is hardier than the peach, it may perhaps succeed, even better in the north, and there is no doubt but that it will take as readily as the peach upon the apricot. I am, &c.

26th April 1828.

I have only to say in addition, that my expectations from the peaches worked upon the apricot-trees were fully realised last season (1827). The fruit was larger and finer than that on the peach-trees ; which confirms me in the opinion that the practice will be of utility.

SHUGBOROUGH GARDENS, }
5th March 1827. }

XXXIX.

Hints and Notices connected with Horticulture.

By JOHN MURRAY, Esq. F. L. S., &c.

(Read 7th June 1821.)

1. *On uniformity of Insular Climate.*

I HAVE briefly treated of this subject in the *Annals of Philosophy*, with reference to Dr MacCulloch's paper on the naturalization of tender exotics. Dr MacCulloch singles out Guernsey as an appropriate nursery for intertropical plants, from which seeds might be ultimately obtained,—the embryos of a race sufficiently hardy for our more frigid clime.

The transitions in this country are sudden and extreme, so that the change from the uniformity of insular climate to the very variable one of Great Britain, might operate as fatally as that from an intertropical clime to the British shores.

The refined speculations on the distribution of heat over the globe, in connection with isothermal

lines, by Baron de Humboldt, serve, certainly, to solve many interesting problems in vegetable physiology, and satisfactorily account, in some instances, for the luxuriance of plants far removed from their indigenous soil,—phenomena, in which we see exotics that have been plucked from the tropics bloom in exalted latitudes. Still, however, the uniformity of insular climate comes in for its full share in the estimate; and it proceeds from a cause which may, I think, be explained; and this I have endeavoured to do in another place.

The ocean preserves an uniform temperature unknown to inland countries; and the difference in its waters, between the summer and brumal months, will not exceed 3° or 4° Fahrenheit. Small islands will especially participate in this uniformity; for the air incumbent on the bosom of the great deep, will receive the impress of its temperature from that on which it constantly reposes and is in contact; and this again, blending with that over the islet, will maintain an equilibrium of temperature, and protect it from sudden vicissitudes.

The following statement of the range of the thermometer, kept at the Bell Rock Light-house, and which I obtained from thence, will go far to corroborate my opinion. The period is from 28th July to 10th August last inclusive, registered each day at 8 o'clock A. M.

1820.		1820.	
July 28.	58° Fahr.	Aug. 4.	61° Fahr.
29.	58	5.	56
30.	62	6.	56
31.	57	7.	56
Aug. 1.	57	8.	59
2.	57	9.	52
3.	60	10.	58

2. *Camellia Japonica.*

I am not aware that the Caledonian Horticultural Society is possessed of a single recorded instance of the naturalization of this beautiful plant. Even at Naples, where the cotton is cultivated in the open fields, I was surprised to find in the Botanic Garden of that city the *Camellia Japonica* confined to the conservatory, the associate of the *Coffea* and *Musa*. Perhaps its rarity there may occasion its imprisonment, for two or three dollars was the price set on a small plant. The single-flowered, however, was permitted to remain in the open garden. The camellia is doubtless as hardy as the *Aucuba* and *Corchorus*. Near to Inverness, in a garden the property of Mr Welsh, the *Camellia Japonica* withstood the severity of the climate, and flowered beautifully in 1819 and 1820. The plant has had no protection or covering whatever. I was informed that the plant, when 18 inches high, was purchased in the spring of 1818, and plunged with its pot into the soil. It was primarily intended to remove it into the house, but being

negligently exposed to a smart frost toward winter, it was not done, seeing it did not apparently suffer thereby. This plant has grown ever since on the face of a dry sandy bank, with an aspect to the south-west, and an inclination of about 45° , being well sheltered from the north and east. It is the double-red variety, and now exceeds two feet in altitude. The garden is nearly a mile from the sea.

I have long been of opinion, that in our endeavours to inure exotics to the severity of our winters, we begin at the wrong end. The summer is even advanced before such plants are brought out of the greenhouse or conservatory. Now, it seems clear to me, that spring is the most proper season, and that too as early as possible, otherwise the sap receives an unnatural check, which ill fits it to mature a structure calculated to resist the winter's storm. But if the sap receives its first momentum, where the plant is destined to stand, the ascent and descent of the sap will be regulated by the same ambient medium, and it will adjust itself to the new circumstances in which it is placed. The sap will thus be perfected in unison with the declension of the season, and the bark and buds be properly encased, and fenced against the frosts and the storms of the brumal months. As far, too, as my own observations go, plants so destined should never be too small.

3. *Preservation of Fruits.*

The high state of preservation in which grapes were introduced at table in the north of Italy, even in the month of January, induced me to inquire into the mode adopted for this end.

Professor Giobert of Turin accordingly informed me, that the grapes detached from the vine in dry weather, and freed from such as were bruised or spoiled, were placed gently, *stratum super stratum*, in a box, to the amount of three or four layers, with interposed thin beds of peach leaves. The boxes thus replenished and shut close, are placed on shelves in a dry airy room.

No doubt any kind of leaves, not succulent, would do equally well, as for instance those of the oak or Spanish chesnut. If the preservative property obtains in an astringent principle, some powdered oak bark might be advantageously used, or if in one antiseptic, powdered charcoal might be employed with success; and why not try the experiment of dipping the apple, pear, &c. in *pyrolignous acid*? In this way grapes of the preceding year's growth are presented at table in a condition to vie in beauty and flavour with those brought immediately from the vineyard. I was elsewhere informed that peaches and nectarines, wrapped up in some absorbent of moisture, and excluded from air, &c. were preserved to a lengthened period.

4. *Fruits in Domestic Wines.*

Malic, citric, and other acids, obtain in the gooseberry, &c. used in domestic wines, and form material obstacles to success. It is therefore an object worthy of inquiry, how far changes operate in mature fruits toward a modification of the acid principle. In the south of Italy, the Italians suspend the bunches of grapes to the ceiling of rooms and in out-sheds, and the taste acquired is sweeter than before, in which, too, the flavour of the raisin predominates. If ripe gooseberries or currants be permitted to remain pendent on the bush, additional saccharine matter seems to be elaborated, and the fruit becomes much sweeter. At Montefriascone, where the Tuscans are famous for their sweet wines in imitation of Malaga, the grapes depend in bunches for some time under convenient sheds, before they are expressed, in order that they may acquire the sweetness requisite; and may not a similar plan be followed with our domestic fruits?

5. *On Wall Trees.*

There are both advantages and disadvantages attendant on wall trees.

In the London Horticultural Transactions, Mr Knight has favoured us with some excellent hints, which we would do well to profit by. These are characterised by all the sagacity and acuteness which so essentially distinguish this eminent master in vegetable physiology.

By detaching the tree, as far as it could be conveniently done, from the wall, and so fixing it till an advanced stage of the bud, Mr Knight obtained from its seeds a hardier offspring than the parent; and the principle on which the plan was adopted is certainly a legitimate inference, clearly founded on experience and analogy.

I feel persuaded, from observations somewhat extended, that it would be well could we so adjust our trees to the wall, as to make removal during winter and early spring frosts practicable. We would thus be able to triumph over the destructive ravages of frosts on the early blossom, and also clear away the chrysalids and ova of insects, with decaying leaves, and other causes and sources of injury. To prevent the friction and destruction occasioned by winds, the trees might be securely fastened forward to temporary stakes. By such means the tree, when re-affixed to the wall, would receive an instant and extraordinary and continued stimulus. We have only to refer to the rich stores of a short but vigorous Canadian summer. I am much deceived if this be a difficult task, provided we use the structure of the nail described in a former number of the *Caledonian Horticultural Memoirs* *.

It was only last year that I remember to have seen in the gardens of the Earl of Mansfield, at Scone, a fruit-tree posited in an angle,—an ample

* Vol. iii. p. 110.

lesson for our instruction. One half of the branches emerging from the trunk overspread a wall with a southern exposure, and the remaining half one with an exposure to the east. The early frosts having destroyed the blossom of the former, it was entirely denuded of fruit, whereas in the latter the fruit was unusually abundant. I have witnessed similar phenomena, where a tree exposed to the south had the terminations of its branches trained over the wall, thereby acquiring a northern aspect.

In the north of Italy, as in Piedmont, &c. it is usual to detach the vines from their upright poles, and lay them prostrate on the ground, placing on them a sod, or a portion of earth, to prevent their being agitated or broken by winds. The snow mantles them with its woolly coverlet, and over their slender and delicate stems frosts have no power.

HULL, }
 May 25. 1821. }

XL.

On the Gooseberry Caterpillars, and the application of Heat for their destruction.

By ROBERT THOM, Esq. Rothesay.

(Read 7th December 1820.)

IN 1819, the green caterpillar being very numerous on my goosberry bushes, (notwithstanding that the ground had been carefully trenched down in winter), I resolved to find if possible some more efficient method of destroying them. To accomplish this with more certainty, I contrived a set of experiments, by which I traced their natural history through all their stages for upwards of sixteen months.

The proper limits of this paper will prevent any detail, or even enumeration of these experiments: I shall therefore only state the result of a few that seem to bear most materially upon the subject.

In the first place let me premise, that instead of one brood in the season, as described by all former writers on the subject, there are often four or five distinct generations; and that two flies, coming up

in the spring, *may* in that season produce above sixty millions of caterpillars !

During the whole of last spring and summer a regular succession of these pupæ were confined in pots, filled with earth, and placed in the garden, so as to have the same exposure as those that went into the earth beside the bushes. Various ingredients were put into these pots with the view of killing the pupæ ; but to no purpose : the flies still continued to come up at the usual periods till the 26th of June, when all at once they ceased ; nor did any that were in the pupæ state in these pots ever come up afterwards.

Suspecting that the great heat of the weather at this time either killed them, or delayed their coming up, I placed a pot containing pupæ, (that had just gone down in the shade), in a cool cellar, and at the usual period the flies came up.

I then took a number of pots, (filled with earth), containing pupæ fully incrustrated ; upon some of which I poured boiling water ; upon some, unslacked lime, pounded to the size of small peas, was put, and mixed with the earth two inches deep ; others were allowed to remain as they were. Flies from the last came up at the usual time ; but those that received the lime or the hot water never produced flies. This was repeated several times, and always with the same result.

In winter, therefore, when all these insects are in

the pupæ state, I would advise cultivators to lift about two inches deep from the surface of the soil in the gooseberry plots, then to spread on hot lime, pounded as before noticed, about three times as thick as ordinary liming, and return the lifted soil over the lime, keeping still the old surface uppermost, and clapping the soil gently down with the back of the spade. Great care must be taken that the lime is unslacked, and regularly spread, as it is merely the *heat* produced by *slacking* that kills them. If the lime is too much for the soil it may be exchanged in the spring by soil from another plot.

When boiling-hot water is used, it should be put on when the soil is *quite dry*, and precisely in the same way as the lime; lifting the soil to the same depth, and returning it in the same manner, as soon as the water is poured on.

In this way the pupæ will be all *above* the hot water or lime, and thereby receive the full effect of the heat as it passes upwards.

Where there is great space between the bushes, some lime or water may be spared, by burying the surface-soil at least a foot deep, and tramping it firmly down in the bottom of the trench: but near the bushes this cannot be done for the roots, as the pupæ frequently attach themselves to the under-sides of these; and hence though trenching down the surface-soil does destroy a part, it can never destroy the whole: and I have even seen a fly come up when the pupa had been buried eight inches deep, and the earth

pressed down upon it.—As to the removal of the soil it is quite useless, as the fly easily finds its way back to the bushes.

As heat appeared to be the only agent fatal to these insects in the pupa state, I next tried its effects upon them in the caterpillar state; and found that water, heated to 140° Fahr., and thrown forcibly upon them through the rose of a watering-pot, kills them; *and without injuring the tenderest leaves on the bushes.* But care must be taken to have the water nearly at that temperature; as, if five degrees lower, it will scarcely kill the larvæ; and if more than five higher, it will injure the bushes: So nearly does the vitality of the caterpillar coincide with that of the leaf on which it feeds.

But water thrown upon them in this way even as low as 120° makes them drop instantly from the bush; and I would therefore recommend to beginners to use the water at this temperature, a cloth being spread under the bush, to collect them for destruction, as afterwards mentioned.

Of all the other things that have been recommended, and many more that I have tried, none kills the caterpillar without injuring the bushes. Here, as usual, the simplest of all agents is the most powerful.

I have contrived a very simple apparatus, (Plate VIII. fig. 3.), by which water is thrown with force upon the under-sides of the leaves; and by which

one person, if supplied with hot water, will go over a hundred bushes in the hour, and not leave a single living caterpillar on one of them.

From a great variety of experiments, I found that the duration of life of the insect varied considerably, according to circumstances, in all its stages, except in the fly state, which appears to be uniformly from nine to eleven days. In this state it seems to take no food. It generally lays most of its ova on the second, third, and fourth days, but sometimes continues to lay a few till the seventh or eighth day. Under the most favourable circumstances the ova are hatched in seven days; the life of the caterpillar is fifteen days, of the pupæ eighteen days. In the most favourable weather for that purpose, therefore, a new generation is produced every forty-two days, namely, four days for the fly to lay its eggs, seven days for these to hatch, fourteen days in the caterpillar, and seventeen in the pupa state; and as the first flies for the season generally come up about the beginning of April, and continue to come up, if the weather is fine, as late as the end of October, there *may* be five distinct generations in one season. They are, however, subject to many incidents, and therefore seldom more than two generations, of any considerable extent, appear in one season.

They are generally said to be extremely voracious, but this is owing to their great numbers; for,

upon an average, each caterpillar barely eats one leaf during its whole life, the female eating more than double of what the male eats. For the first five or six days they eat very little, each at that time having made only a small hole in the leaf, of about one-tenth of an inch diameter. It is in the last four or five days that they make the havoc on the bushes; and the damage is therefore nearly all done before it is discovered. Those who look properly after them, however, have time enough to prevent it, by destroying them while young. When just emerging from the ova, they are extremely helpless, and easily destroyed. A heavy shower, or blast of wind, will then throw them to the ground, where they perish. This is the weak period in their existence, and probably at this stage nine-tenths of the whole perish upon the average of years; and hence it is only in particular seasons that we hear much of them. Calm, mild, but rather moist and cloudy weather, is most favourable for them at this stage; but after they are a few days old, no weather will kill them, although favourable weather brings them sooner to maturity.

The insect is male and female, but the ova of the female produce caterpillars, even when the male and female flies are kept separate. How long this offspring would continue to breed has not been ascertained; but by following up the experiments it might be very easily done. There is some reason to suspect that there is a connection between the male

and female *caterpillars*; for I have frequently observed them twisted together for some time after they had ceased eating, and a little before they cast their skins to go into the pupa state. By a little more attention this may be fully ascertained.

A male and female fly are herewith sent. The female is brighter in the colours, and much larger than the male, particularly in the abdomen. The body of the fly is barely half an inch in length; its head and thorax of a fine purple, and its neck and abdomen a bright orange colour. It has two antennæ, about three-eighths of an inch long, with which it seems to feel its way; four wings (the one resting over the other), very thin and transparent, except a dark spot near the extremity of each incumbent wing.

A few of the experiments, and a description of the apparatus for destroying the caterpillar, follow.

July 27. 1819.—Collected a number of the green gooseberry caterpillar from the bushes, and put them into a tumbler, along with fresh leaves from bushes, changed twice a-day. The tumbler was covered with a piece of gauze, or of tin-plate, perforated with small holes, to admit air and prevent the escape of the caterpillars.

They continued to feed on these leaves for two days, when one of them began to appear restless, and run up and down the sides of the tumbler. In a little it laid itself down on the bottom of the

tumbler, on its side, with the body a little curved, moving its limbs and body in an indolent manner, like a dog basking in the sun. In a minute or so I observed the head of the insect change from a greenish to a yellowish-white, and nearly transparent. By slow degrees the light transparent colour moved from the head down the body, till the dark-greenish colour was entirely gone, and the whole had assumed a whitish-yellow, the head, and a little at the other end, being rather of a deeper yellow than the rest. In a word, it had thus shoved off its outer skin, which now lay empty behind it. The whole time occupied in this operation might be from five to six minutes. For some time after this it appeared fatigued, and lay quite motionless; then began to move about, at first very slowly, but by degrees faster and faster, till at length it moved with an agility that it had never before exhibited. From its restless manner I suspected it wanted something which it could not find. At last, appearing tired, it crept under some of the leaves, to which it attached itself in a somewhat curved position. In the course of a day it had glued itself to the leaf, became only about half its former length, and twice the thickness, beginning to be covered with a new coat, dark where it joined the leaf, and lighter as it rose upon its body. In two days the whole was covered with this dark crust, which I afterwards found to be extremely tough, so much so, that

it required considerable force to tear it asunder. I then put a quantity of earth into another tumbler, with leaves, and the remaining caterpillars above it ; and in two days more they had all undergone the process above described ; but with this difference, that instead of attaching themselves to a gooseberry leaf, they buried themselves in the earth. Sometimes, however, they would lie under a leaf for nearly a whole day after they had thrown off the coat, but they all went down ultimately. In going into the earth, they used their paws like a mole ; which, on examination by a microscope, I found well adapted for that purpose. The last of them went into the earth, on the 1st of August ; and the first fly came up on the 22d, having been three weeks in the pupa state.

On the 2d of September another came up ; after this no more came up till the 1st of May following, when a third came up, and on the 17th a fourth came up. This proves that they may remain under ground from three weeks to nearly ten months, according to the weather and other circumstances. The fly that appeared on the first of May was put upon a twig of a gooseberry bush, stuck into earth in a flower-pot, and covered so as to prevent escape, but admit light and air. On the 10th it died, after having laid 120 eggs on the leaves of the twig. By watering the earth in the flower-pot, the twig took root and the leaves kept quite fresh, and the young caterpillars came into life from the 15th to

the 20th. Those that came into life on the 15th were at their full size on the 28th, and went into the pupa state on the 31st.

August 6.—Having observed that a part of the caterpillars as well as the flies were much smaller than the others, I suspected that the one sort were males and the other females. To ascertain this, a number of the small caterpillars were put by themselves into a flower-pot, in which grew a small gooseberry bush, on which they fed; and then went into the pupa state there. In due time small flies came up; and were prevented from escaping, (which they frequently attempted) by a gauze covering. In nine days they all died without laying any eggs. The same thing was done with the larger sort of caterpillars, and in due time large flies came up, which were similarly confined; they immediately began to lay eggs, and in three days each had laid about 140 eggs. On the tenth day they all died, after having laid about 160 eggs each. In nine days after the first eggs were laid, the first caterpillars came to life; they fed upon the leaves for from sixteen to twenty days, and then went into the pupa state. Similar experiments were often repeated, and always with the same result; which proved that the insect is male and female, but that the eggs of the female produce caterpillars, although kept from any connection with the male in the fly state.

August 24.—Confined a male fly and a female fly together, that had just come up, by putting them into a large tumbler, in which was a twig of a gooseberry bush, and covered with gauze. The male immediately began to follow the female up and down the sides of the tumbler, and from branch to branch of the little bush ; and whenever he touched her with his antennæ, he turned round his posterior end to hers; for a while she seemed shy and made off, but in the course of five or six minutes she stood still, when the male placed his posterior end under hers, and in this state fell to the bottom of the tumbler, and continued to stick so for about a minute. In a little after this, I put in another male fly beside them ; and when the two males met, it was always in rather a hostile attitude, but the one almost instantly fled from the other. I observed them for about an hour after this, but none of the males seemed to pay farther court to the female. The male flies are much more lively, and move about much more than the females ; the last, indeed, seem never to move farther than is necessary from one leaf to another in laying the eggs, and that done, they sleep quietly away. Hence few have ever seen this fly.

August 24.—To ascertain what one caterpillar eats ; as soon as the caterpillars came into life, they were all destroyed but six, one on each leaf. Then, as soon as they could be removed with safety, and when each had only made a hole about one-tenth

of an inch diameter in its leaf), each was put into a separate pot, into which grew a very small gooseberry bush;—a small twig with a few leaves that had taken root there. They continued to feed, and thrive well for the usual time, when they went into the pupa state. The largest females had each eaten fully one and a half leaves, the smaller ones rather less; upon an average one and a half leaves for each female, and only about half a leaf for each male. This was often repeated, and the result always very nearly the same.

ROTHESAY,
5th September 1820. }

Explanation of the Figure, Plate VIII. Fig. 3.

- A, A tin vessel, one foot diameter and same depth, standing on three legs, fully four feet high from the ground to the bottom of the vessel.
- A B, A tin pipe (communicating with the tin vessel) 2 inches wide at A, and $1\frac{1}{2}$ at B.
- B C, A leathern tube of $1\frac{1}{2}$ inch bore, screwed upon that pipe at B, having a stop-cock of same bore at C, and a rose, like that of a watering-pot at D, but nearly flat in front, so as not to *spread* the water too much. The *size* of the rose must be such as not to pass the water quite so fast as it comes; otherwise, from want of pressure, the water would not be thrown with sufficient *force* upon the caterpillars.

Having placed this apparatus near the bush, fill it with water heated to 140° : then with one hand open the stop-cock, and with the other direct the jet upon the caterpillars.

A forcing pump or any apparatus that will throw the water forcibly upon the under sides of the leaves, where the caterpillars feed, will answer the same purpose; but the water must be thrown pretty forcibly, as the caterpillars on one leaf are sheltered by the intervention of other leaves; and, therefore, it is necessary to give each branch a *smart shake* immediately on its being struck by the water, as this brings all the caterpillars to the ground, even if not quite killed. On this account a cloth, (or something like a large sieve), in two halves, should be spread upon the ground under the bush, by which means the caterpillars are easily collected and destroyed: for, otherwise, some of them, from being sheltered by intervening leaves, would recover and regain the bush.

Might not the pupæ be destroyed in the ground by laying horse-dung over the surface, or any thing else that would ferment and produce heat? If the ground were pared about $1\frac{3}{4}$ inch deep, and turned upside down before this was done, probably it would assist. Even a whole winter's season might destroy them if thus exposed to the weather, for they are very careful, not only to bury themselves in the ground, but always *under the shelter of the bush* upon which they feed:—Or, might not the larvæ be destroyed by steam, instead of hot water; the bush being covered by something like an umbrella, with the bulb of a thermometer below, and the stem above, to indicate the proper temperature? The steam could easily be produced by an apparatus contrived for the purpose, so light as to be moved from bush to bush by one person. Might not the effect of this be tried in greenhouses and vineries?

XLI.

On the Cultivation of Onions; on Preparing Ground for Carrots; and on Destroying the Gooseberry Caterpillar.

In a Letter from Mr JOHN WALLACE, Gardener at Ballechin, to the Secretary.

(*Read 8th March 1815.*)

SIR,

AS the cultivation of Onions is a matter of considerable importance, I beg leave to lay before the Society the method which I have pursued for several years past, having had the pleasure to find my crop of them never fail to answer expectation. I shall also state the method I used with my carrot-ground, and which has seldom failed to answer well. If you think the communication of any consequence to the Horticultural Society, please present it.

Onions.—The garden here is of a light soil, and for some years after my coming to this place, I always digged my onion ground twice a-year, viz. in autumn and spring, giving a good coating of dung

in harvest, and a light one in spring, before sowing the seed. My crop of onions did not answer my expectations, and, besides, it was infested with the maggot. I followed this course for two or three years, and found the onions turning worse and worse every succeeding season. I then determined to alter my plan; and, in the end of autumn, when the onions were taken up, I only raked the ground, and cleaned it of weeds, but did not dig it. In the spring, when the season of sowing came, I gave the ground a moderate coat of well-rotted cow-dung, as free of straw as I could, and then digged the ground half-spade deep, and pretty rough, on which I sowed the seed; and that year I had the satisfaction to find that the crop exceeded my most sanguine hopes, for the beds were a perfect sole of onions, and many of them exceeding large, measuring from ten to fourteen inches in circumference. The crop was entirely free of the maggot. I have followed the same method for the last four years, and the result is constantly the same; for last year (1813) the crop of onions failed in most places, so far as I have heard; but mine answered the same as usual, being indeed rather thinner, but very large and perfectly sound. They were seen by Mr Stewart of Dalguise, a member of this Society. All the reason that I can assign for this is, that I find light and dry soils are rather hurt than benefited by too much labour and pulverising the ground; and I was led at first to adopt this method, from

observing that such of the tenants in my neighbourhood, as gave repeated ploughings to their bear land, had seldom but a very poor crop after it.

I should have mentioned, that I always take care to keep all the chimney soot I can get, in a barrel or tub ready for use; and when I sow the seed, I spread a thin covering of soot on the beds, along with the seed, and then rake over the whole. The employment of the soot is probably a thing of great importance in preventing the attacks of wire-worm or maggots. The quantity of ground I have yearly under onions, is never less than forty, and sometimes fifty falls.

Carrots.—With regard to my crops of carrots, I had often been disappointed in them, till I thought of trenching the ground. This I do only a few days before sowing, to the depth of eighteen or twenty inches; after this I level the ground, and give it a coat of rotten cow-dung, and then dig half-spade deep, on which I sow the carrots. Ever since I adopted this plan, the crop has answered to my mind; the carrots are large, and free of maggot. When I sow the seed, I give the ground a very thin covering of dry soot and hot lime, and I change the ground for them every year. The time I sow them for my general crop is from the 20th of April to the 1st of May; and I always find it to be much in their favour to thin them to their proper distance at giving the first weeding.

Gooseberry Caterpillar.—I may here add, that I have seen several methods of destroying the caterpillar on gooseberry bushes, &c. I have tried some of them, which I found answer tolerably well; but some years ago I was infested with them to a very high degree, and they seemed to put me at defiance. There happened to be a quantity of quicklime at hand; I took about six pecks of it, and put it in a large stand full of water, where I let it continue some time (about six hours); and then, about mid-day, when the sun shone strong, I took a watering-pot, and watered all the bushes (the top of them) with the infusion. The next day I found but very little impression from this first watering; however, I gave them a second dose about mid-day (always when the sun shone strongly); and on the third day, gave them another of the same kind. On the day following this third dose, not one caterpillar could be found on any bush in the garden, they lying in crowds dead below the bushes. Whenever they appear, I always use the same method, and the success is constantly the same. I do not find that the foliage of the gooseberry bushes is injured by the application.

BALLECHIN, by Logierat, }
26th September 1814. }

XLII.

*Notice regarding the Scarificator figured in
Plate VIII. fig. 5.*

In a Letter from JOHN GORDON, Esq. to the Right Honourable Sir JOHN SINCLAIR, Bart.

*(Communicated to the Caledonian Horticultural Society,
and read 3d February 1825.)*

SIR,

HAVING been in the way of planting for the greatest part of my lifetime, both in England and Scotland, I take the liberty of submitting to you a simple instrument for scoring or slitting the bark of trees.

I have uniformly found the greatest benefit arise from cutting or slitting the rind of fruit-trees when *hide-bound*, or any way in a stagnated seat. This is often done on the stem of the tree; but is of little use unless carefully done down to the surface of the ground, or rather below, and likewise a little along the horizontal branches. I have often seen trees

carefully done in this way, in blossom several days before those not cut at all. By using a proper instrument the slitting may be done in less than a minute per tree ; and the tree will want no more relief for some years.

I have often seen great service done also to *forest* trees by a similar practice. In the New Forest in Hampshire, an active workman employed by the late Lord Glenbervie was able to score or slit 3000 forest trees in a day ! Let the benefit to each tree be ever so small, this labour must pay well.

I have therefore sent a small instrument which I made for the purpose. It will be found far before the knife. It is made so as to penetrate the bark to a certain depth, and no farther. The one side with the deeper blade, is for the stems of large trees, and the other with the shallower blade is for the upper branches, or for young trees. It is evident that this implement can be used with more freedom than the garden knife, as the operator has not to think about the depth of his cut, or the force exerted. Even in careful hands, the knife often slips over, and at other times it cuts too deep.

Allow me to mention in regard to fruit-trees, that I have at this time on the Ayrshire coast some thousands of all sorts of fruit-trees in progress in the nursery, without any tap roots at all. This I find can very easily be accomplished in light kindly soils. Fruit-trees should never be planted with

long tap roots ; for such are a long time before they do any good, and they soon begin to decay. The roots should be small and horizontal, that every one may go in search of nourishment near the surface, around the tree.

HAMILTON,
10th *January* 1825. }

XLIII.

Notice of an Improved Garden Hammer.

In a Letter to the Secretary, from Mr JOHN DICK, Gardener at Ballindean.

(*Read 3d February 1825.*)

See Plate VIII. Fig. 6.

SIR,

I BEG leave to send to the Horticultural Society, by the favour of William Trotter, Esq. of Ballindean, an improved garden hammer. This hammer, you will observe, has a stud or guard projecting from the head in the direction of the handle, but somewhat nearer to the face of the hammer than the handle is. I find this projecting stud to be of great importance in working on a fruit-wall close set with branches and twigs, especially among the bearing twigs and young wood of peach-trees. It serves as a fulcrum; and enables me to draw the nails in every direction, without the risk of bruising the adjacent twig, which can lie snug between the claws and the stud. A very little practice will make any gardener familiar with the use of this hammer, and he will soon feel its advantages. I am, &c.

BALLINDEAN, }
15th January 1825. }



At a Council Meeting, held on the 3d of February 1825, the Society's Silver Medal was awarded to Mr Dick for his useful garden inventions: particularly for this fruit-wall hammer, as a real, though simple, improvement on that implement; and for his barrow and tub for wheeling water from one part of a garden to another.

P. N. *Sec.*

XLIV.

Description of, and directions for using, a New Preservative Frame for saving Wall Fruit from being destroyed by wasps, blue-flies, or birds, when it is ripe ; and also for protecting the blossom in spring from frost, and ensuring a crop of fruit.

By Mr JOHN DICK, Gardener to WILLIAM TROTTER, Esq. of Ballindean, Lord Provost of Edinburgh.

(*Read 6th April 1826.*)

See Plate IX.

THE wooden frame is put together at the four corners, and is fastened with pins N N N N to keep it square. There are two iron holdfasts, put into the wall for each side of the frame, which keep it quite steady to the wall. The facings in front of the frame are represented by A A A A. The front of the frame has a chack round it, with a piece of strong wire, B B B B, which goes along the top chack and also the bottom chack. Therings upon the cloth screen are put upon the wire in the^s chacks. The front facing upon the bottom chack folds down, C C, to let the screen be put into the chacks, and is then folded up and fastened. Then the wire, with the thumb-screws upon it, is screwed up, to tighten

the wire, for the cloth screen to run upon. The two stenters upon the sides of the cloth, are fastened with hooks and eyes, to keep it fast. Then the cloth screen will move from side to side as it may be wanted; and when the screen is required to stand open for any time, the cloth is tied with two strings at whatever side it is at, to keep it from being blown about with the wind. There is a narrow piece of cloth, D D D D, bound round with tape, and loops upon the sides. The one side has two loops, the other several, which are put upon nails in the walls. The two loops are hung upon two small pins E E, that are put into two holes in the bottom of the frame, just by the side of the chacks; and the other two corners of the cloth are put upon a nail F F at the sides of the frame. Then the narrow cloth forms a bag, to receive the fruit that may drop, at the same time keeping the fruit from being destroyed by its fall. This is chiefly useful for peaches, plums, and apricots, but may be used for pears and apples. Cherries are not so ready to drop from the trees when ripe as other fruit are.

I shall now point out the method for using the frames, for preserving the blossom from frost in spring. The frame is put as close upon the trees as possible, only not to hurt them. If the trees have long old spurs upon them, a spur or two may be taken off, where the frame comes upon them, to let it go close to the trees; and there is a circular hole taken out of the bottom part of the frame, which is

put upon the stem of the tree at the bottom or top, according to the size of the tree ; this lets the frame be close fitted to the tree. The time for putting the frame upon the trees in spring is a little before the flower-buds open ; but this must be left to the judgment of the gardener or manager, and it also depends on the situation of the place, whether it is a late or early situation. In fine days the screen can be open for the best part of the day, when there is no frost flying about ; but although the screen were not opened throughout the day at all, the trees will not be hurt in the least degree, because the cloth is so thin that it will admit plenty of sun and air. The time for taking off the frame again, is when the fruit is fully set, and of a size to stand the weather. As peach trees and plum trees are very often attacked with the green fly in the spring, before the fruit is fully set, the screen will shift from side to side, so as to let the trees be washed with whatever the gardener knows will destroy the green flies, before that the frame be taken off altogether from spring use.

I shall now inform you how the wasps and birds of all kinds, and the flies, are kept from the fruit when it is ripe. The frame is put upon the trees for preserving the fruit, in the same way as it is put upon the trees in spring, for protecting the blossom ; and when it is fully fixed to the wall, there is a little clean moss or fog, taken and put in between the edge of the frame and the wall, in as close a manner as it can be, not to leave any holes where the

wasps or flies could get in between the wall and the frame; for they cannot get in by the chacks or the screen. All the time that the fruit is upon the trees when ripening, at this season, the trees will not be hurt, either by the moss or the frame; and if a lady or gentleman wants to pull a few fruit at any time, that can be done very easily; as the screen shifts so quick, that if there are any wasps flying about, they can be drove out in a moment of time, and the screen shut again. If cherries, or any other fruit, are wanted to hang upon the trees, it can be kept on them as long as may be thought necessary. The frame is made to slope a little at the top, to let the rain, or the hail, in spring run off it; and the bottom chack in front, has a few small holes, to let the rain run through it in time of a shower.

I shall now give a few hints how the frame may be enlarged to any size wanted. As the model sent has all the iron and wood work that is necessary, for a much larger frame, the size of the wire, with thumb-screws upon its ends, can be lengthened to bear other three breadths of the cloth; and wire one size thicker will carry eight breadths of the cloth, which will be nearly twenty-four feet in length; therefore, a much larger frame can be made, with a deal of less expence in proportion, than a small one, as a very little more workmanship does, and a little more material does also.

The frame should be put upon the wall a little below the coping, at the top of the wall, and twenty

inches is sufficiently near the bottom of the wall, as there is not much fruit below that height from the ground ; but it can be put higher or lower as the trees require it, or as the proprietor may judge fit.

The wooden part of the frame should be well painted with white-lead, and it will last a number of years, and the iron holdfasts may remain in the walls. The cloth-screen, when taken out of the frame, when it is not in use, should be kept in a dry room, from rats or mice, as they are fond to cut it ; and a little camphor should be sprinkled among the cloth, to keep the moths from destroying it. If it be well taken care of, the cloth will last for seven or eight years : suitable cloth can be got for 5d. per yard, at the present time.

I have stated every thing plainly, respecting the model ; and, if the above directions be properly attended to, the result will be satisfactory and successful. Any gentleman who may put it in practice, will, in the end, be amply rewarded for his trouble. And I now, from full confidence and experience, lay the model before the Caledonian Horticultural Society.

To PATRICK NEILL, Esq. Sec. Cal. Hort. Soc.

DEAR SIR,

I beg you will have the goodness to lay this paper, with the accompanying model, before the So-

ciety for their investigation. I am, with the utmost respect, &c.

JOHN DICK.

BALLINDEAN, }
30th January 1826. }

N. B.—The model is made of such size that it can be made use of for trial and experiment. The total expence of such a frame is L. 1, 12s.

At a Meeting of the Council, held 6th April 1826, a remit was made to Messrs Andrew Dickson and John Hay, to examine Mr Dick's wall-tree frame, and to report their opinion. At a meeting of Council held 15th June 1826, the following report was given in.

Edinburgh, 1st June 1826.

Agreeably to the remit made to us by the Council, we this day examined the frame with a canvas screen, for protecting fruit trees when in blossom, and the fruit when ripe, invented by Mr John Dick, gardener to William Trotter, Esq. of Ballindean; and we beg leave to report, that, in our opinion, the frame will be found of great service in protecting fruit-trees when in blossom, and will most

effectually secure the fruit when ripe from the ravages of birds, wasps, and flies. The facility with which it can be opened and shut adds much to its merit; and we humbly suggest that Mr Dick should have some suitable mark of the Society's approbation of his invention. That its properties may be seen, we would advise that the frame be put up in the Society's Garden, where it may be examined in all its details.

(Signed) AND. DICKSON.
JOHN HAY.

The Society's silver Medal was accordingly awarded to Mr John Dick, and the frame was erected against a wall in the Experimental Garden at Inverleith, for general inspection,

P. N. *Sec.*

EXPLANATION OF PLATE IX.

- A A A A—Facings in the front of the frame.
- B B B B—The check and wire.
- C C—The bottom part of the facing folded down.
- D D D D—Narrow piece of cloth, to hold the fruit that may fall.
- E E—The two wooden pins of ditto.
- F F—Nails to tuck up the ends of ditto.
- G G—A section of the frame.
- H H H H—Thumb-screws for tightening the wire, should it bag.
- I I I I—Hooks to fasten on the facings.
- K K K—The cloth.

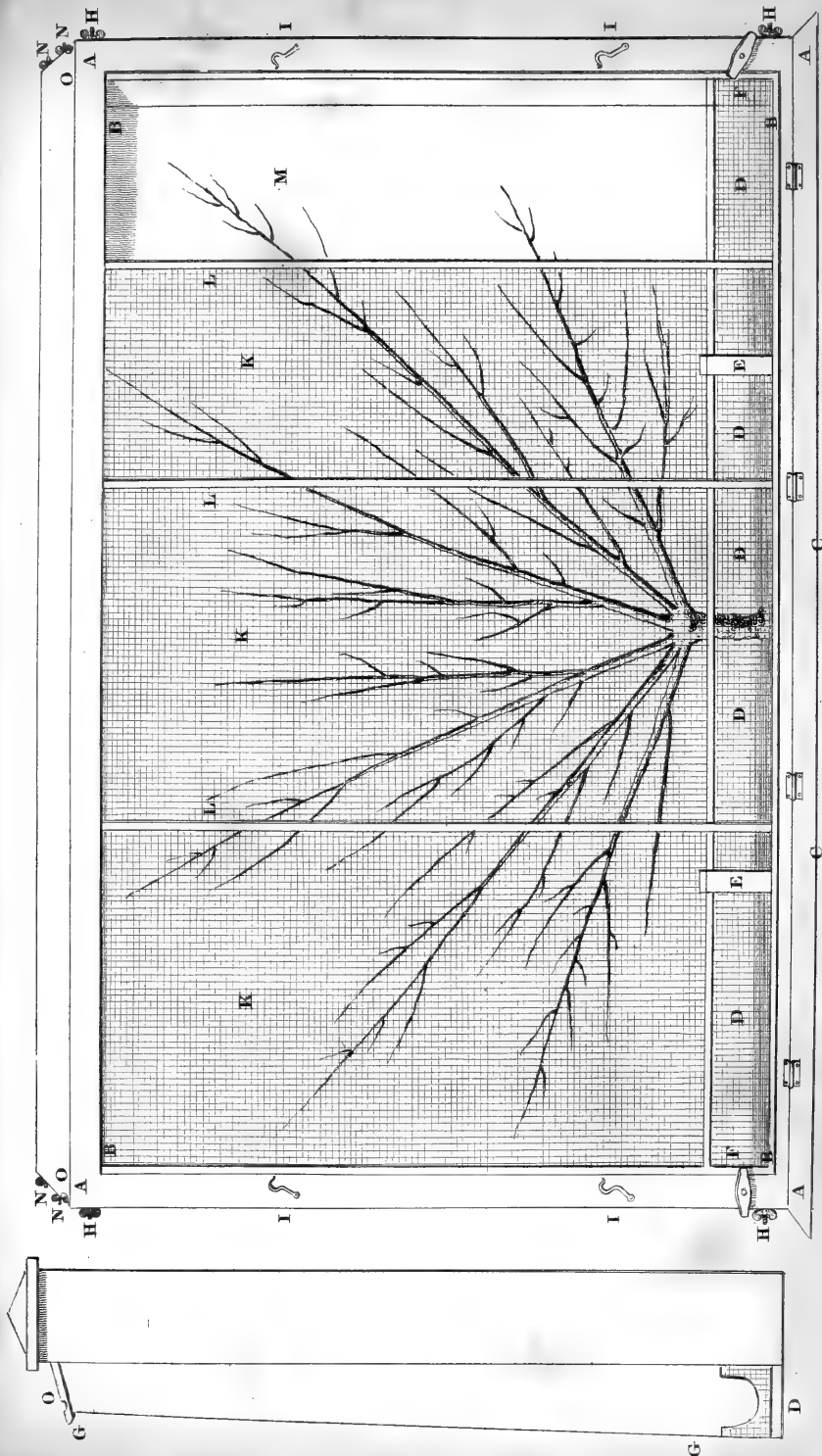

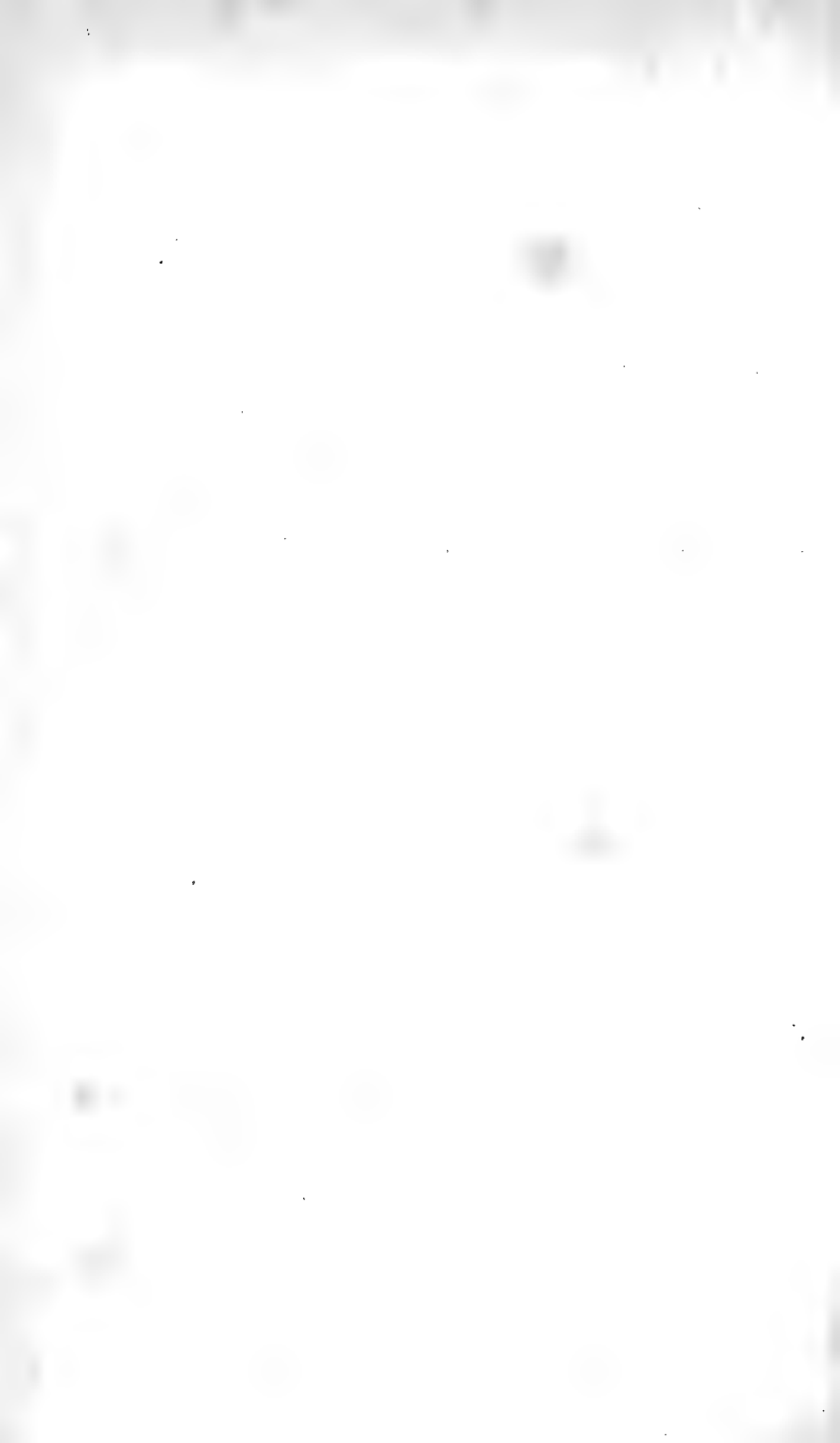

L L L—The seams of the cloth strengthened with tape.

M—Space shewing where the cloth has been drawn back.

N N N N—The ends of the frame put up and down through the top and bottom of the frame, which are fixed with an iron or wooden pin.

O O O—The rain that runs off the top or stop of the frame may wet and rot the cloth: it might prevent this, if the frame was made a little higher at one end, and a small groove or spout cut out of the front of the top, as seen at O O O, to let the rain run off at the lower end.

XLV.

On the Cultivation of Strawberries.

By Mr JOHN MIDDLETON, Gardener at Tillychewan. In
a Letter to the late Mr T. DICKSON, Secretary.

(Read 13th December 1814.)

SIR,

IN compliance with the resolution of the Society, which requires that every person whom it honours with the distinction of being a corresponding member of the institution, should contribute something to the general stock of horticultural information, I take up my pen, in order to add my mite, by giving some account of my method of cultivating the strawberry.

I begin by giving a short description of a few of the principal varieties which I have seen cultivated in Scotland. The first is the *Virginian* or *Scarlet*, and which is pretty generally considered as the best flavoured sort. The second I name is the *Red Alpine*, which sort, I think, comes nearest to the Vir-

ginian in point of flavour. It is also the latest strawberry we have, at least it continues longest in fruit: for I have observed, that even when planted in a northern exposure, its fruit begins to ripen as soon as that of the other large kinds; and in a warmer situation, and when it is not shaded, in a few days after the Virginian. The next variety, and which I look upon as holding the third place in point of flavour, is the *Surinam* or *Pine*; its foliage is not very different in appearance from that of the other large sorts, but its fruit is of a deep red colour. It is a good bearer, a little earlier than the other large kinds, and I think excels them considerably in richness of flavour. The fourth variety I mention, is that known by the name of the *Chili*, of which there is one variety with white fruit; and another with red fruit; and a third, lately introduced into this quarter, with several other new sorts, by Mr Thomson, gardener at Erskine House, which is of a more dwarfish growth than the other two. The fruit of this is also red, and it seems to be a good bearer. I believe it is generally known, that this kind, notwithstanding its name, is not indigenous to Chili, but to the *Carolinas*, from whence it ought to take its name. There is, however, a strawberry a native of Chili, of the dioecious kind, of which the female plant only has been introduced into Europe, the fruit of which is said to grow to the size of a pullet's egg. It requires to be planted among hautboys to make it produce fruit; its own

male plant, as observed above, having, as far as I have heard, never been introduced. I remember having read that the French Academy gave instructions to the botanist who accompanied the unfortunate La Peyrouse, to endeavour, when at Chili, to procure the male plant of this variety.

The above named sorts (except the last) being those I have been most in the habit of cultivating, I proceed to offer a few remarks on the *soils* best adapted to their successful cultivation. A strong soil, inclining to clay, answers best for the Virginian and Alpine; but the large sorts flourish on soils of a lighter consistency. That strong soils answer strawberries best in general, is, I believe, pretty commonly allowed; yet I can say, from experience, that I have had a poor crop of the Carolina sort on a border made up of very strong soil for pear trees; whilst, on a part of the same ground, planted with Virginian strawberries, the crop was excellent; and the crop of Carolinas, on light land, in the same garden, was amazingly abundant.

As to *situation*, I always prefer that which is open and airy, except for the Alpine kinds, which a northern shaded border has not only the effect of preserving till a later period of the season, but it ensures a heavier crop. In shady situations, however, their flavour is rather inferior, and they produce very good crops in open exposures.

In regard to the management of the plants for a crop, I follow the ordinary method of planting in rows, of from 20 to 30 inches asunder, according to the kind. Every gardener knows, that another part of the same mode is, to cut over the plants in the month of October, in order to make them push anew, and *cover themselves*, as it is termed, before winter: this part of the management I have been induced, from experience of its bad effects, to omit. I was at first led to this change, from observing, that a plot of strawberries, which, through the hurry of business, I did not get dressed in autumn, produced very well next season: it immediately occurred to me, and in the same sentiment I now write this, that strawberries, and in general any herbaceous plants resembling them in habit, must be very much weakened by being made to produce two crops of foliage in one season. The winter residences of the shoots, which are to come forth next spring, must be thrown open, and the whole plants considerably weakened by being forced to exert themselves in sending out a numerous and weakly set of autumnal leaves, and by these means a very sensible effect must be produced on the crop. I therefore make it a rule, after the crop is gathered, to cut away all the runners, and to clear the beds of all weeds, but I never touch the bodies of the plants in the way of cutting. I observe, that, during winter, the shoots of next year are seen strong and healthy, under the

shelter of the decayed foliage, from which they no doubt receive much protection.

For the following direction, I have to acknowledge my obligation to Mr Lang, gardener at Balloch Castle, for whose abilities as a gardener I feel the highest respect ; it is,—never to dig betwixt the rows of strawberries in autumn. Such a practice, he very properly remarks, by cutting large quantities of the fibres at that season, must have the effect of injuring the plants almost as much as if they were transplanted. The new made wounds are, by the ground being opened, exposed to the action of the frost, and the plants will, by this treatment, be kept in a weak and languishing state during the whole of next season. The only necessary operation, therefore, is, to give the whole ground a complete hoeing after the runners are cut off, to clear away the weeds ; and if the alleys on the out sides of the plots are dug, to cast a small quantity of loose earth on the whole ground, which will give it the appearance of being newly dressed. I have found, I think, great benefit from wheeling on, during frost, a quantity of well rotted dung, and pointing in the same, in the months of March or April, when the plants should receive their spring dressing, which must, of course, consist in cutting off the old haulm, clearing the bushes of any weeds which may then appear, and digging the whole ground betwixt them. It must be obvious, that cutting a few of the roots at this season will in no degree retard the growth of

the plants, but by the additional quantity of fibres produced in consequence of any incisions which may be made, will materially promote the same.

Such, Sir, are the few remarks on strawberry culture which I have to lay before you. I am well aware that they contain but little that can be called new, and that the subject is handled in a manner which will perhaps appear to men of extensive practice, to be narrow and restricted: but as we every day, at least in this quarter, see instances of gardens, some of them of no small dimensions, where the strawberry crop is very indifferent, and sometimes where there is no crop at all; and as this failure is certainly to be attributed in no small degree to bad management, I hope the candid inquirer will not consider my paper as wholly useless. The principal object I have kept in view has been, to give a recital of such facts as have come within my own observation, observing an entire silence on those branches of the subject on which, from want of experience, or want of success, I have not been able to suggest any thing either interesting or instructive. For the first of these reasons, I omit saying any thing on a method I have heard mentioned, of obtaining Virginian strawberries at a late season, by cutting them over previous to their coming in flower; and, for the second, I do not mention the *Hautboy strawberry*, and the many new sorts which are every year coming in. I have cultivated the Hautboy,

but with inferior success compared with the other sorts, and I have had some of the new kinds, and have always thought them inferior to those I have been describing. I am, &c.

As I find that the *Red Alpine* is not generally known to gardeners, I may mention what I know of its history. It had been procured in London by the late John Stirling, Esq. of Tillychewan, along with several other sorts of the same fruit about twenty-six years ago; I found it in a neglected state when I went there, but I was not aware that it was a variety different from other red alpiners, until I came to Blythswood, seven years ago; I was struck with the wretched appearance of the Alpine Strawberries growing then at this place, and procured from my successor at Tillychewan, plants of the red alpine of that place; the abundance of the crop, and the flavour of the fruit, attracted universal notice; and as our family is visited by gentry from many parts of the country, a bundle of our alpiners formed part of the luggage of many on their return from the hospitable mansion of Blythswood; from this circumstance I should think their merit or demerit might be by this time well ascertained; but I also gave to Mr Barnet a parcel of the same plants last year in the month of April, and you will of course have the means of becoming perfectly acquainted with their qualities.

In the autumn of 1826, I collected some seeds of the above fruit, which I sowed directly,—a good

number came up the same season. I have them at present shewing fruit in great plenty; and they are decidedly the most forward of any strawberries we have at this place.

Since Mr Middleton wrote, several excellent new kinds of strawberry have been introduced; particularly, the Roseberry of Aberdeen; Keen's Imperial; Keen's Seedling; the Downton; the Grove-end Scarlet, American Scarlet, and Bostock. In the Transactions of the Horticultural Society of London, vol. v. Mr Barnet (now of the Experimental Garden at Edinburgh) has described and classified all the different sorts cultivated in England.—EDIT.

XLVI.

On Saving the Seeds of some Culinary Vegetables and Ornamental Flowers in Scotland.

In a Letter to the Secretary, from the late ALEX. HENDERSON, Esq. dated 7th December 1818.

(*Read 4th March 1819.*)

I HAVE often thought the seedsmen in this country might save several varieties of seeds, that we are accustomed to import from the Continent, particularly the Early White flat Dutch Turnip, and Yellow Garden Turnip:—the latter I have often tried with success; but not the white till this season. In spring 1817, I had prepared, in my nurseries, Leith Walk, a large quarter of ground for sowing birch and alder seeds; they were sown, but did not succeed, either from the dry season, or the seed being bad in quality. I then resolved to sow the whole, in June, with early white turnip, which I had imported from Rotterdam. The crop succeeded very well. I did not sow earlier than June, as the turnips are more liable to be injured by autumnal frosts when large. I had each bulb carefully examined, and did not find a dozen of what

are technically called *rogues*, in the whole extent. I planted them for producing seed this year (1818). When in flower, they promised a very weighty crop; the flowers set well; but, although I kept a herd to protect the seed from birds, yet they destroyed a great deal. I sometimes found the herd fast asleep, and hundreds of birds devouring the seed; yet, after all, I had a great reversion. The ground measured 142 falls, which is considerably under an acre. I calculated that I would save about 15 cwt.; it, however, turned out much more. The plants were cut over the last week of July, and allowed to lie in lines upon the ground for about eight days, then laid upon sheets of canvas, and thrashed out upon the spot. The seed was spread on an airy loft, and turned daily for a month; it was then completely dry, and weighed off. The nett produce was 5 lb. short of 24 cwt., or 2,683 lb., which, if sold at the prices asked by the London seedsmen this season, of 140s. per cwt., would bring about L. 168, being an excellent return for two years of that extent of ground. The duty on this seed alone would have come to more than L. 100, at the garden-seed duty of 9d. per pound.

I saved this season about 200 lb. mignonette; I have seen this seed at a guinea per pound. I should, however, be satisfied with less than the half. I am, &c.

XLVII.

On Forcing of Sea-Kale, and on the Culture of Sicilian Broccoli, &c.

In a Letter to the Secretary, from EDMUND CARTWRIGHT,
Esq.

(Read 9th June 1818.)

SIR,

IN the hope of being able to promote, in some small degree at least, the views of your Society, I beg leave to offer, to their notice, an improved method of *forcing Sea-Kale*,—a subject to which their attention, I observe, has more than once been directed. The method which I have practised with invariable success, for these six or seven years past, is simply this: As soon as the leaves begin to decay, which is usually about the latter end of October, the roots intended for forcing are taken up and transplanted into boxes of common earth, not too wet, and then placed in a dark cellar, out of the reach of frost. The plants may be expected to come into use in about six or eight weeks. If three or four boxes follow in succession, at intervals of a month, there will be a regular supply through the winter, as each box will admit of being cut twice. As the roots may be planted close to each other, they will occupy very little space. A box, eighteen

inches square, will commodiously hold at least eight roots. It is needless to observe, that the larger the crown, and the stronger the root, the finer will be the produce. The darkness necessarily produces blanching or etiolation.

Immediately after the second cutting, the roots are removed into the open ground, there to remain till they have recovered themselves, and are ready for a renewal of the operation.

Sicilian Broccoli.—A friend of mine, who visited Sicily in the year 1815, brought from thence some broccoli seed, of a particularly good kind, that had not been before introduced into this island. Knowing that my amusements were now chiefly confined to a small experimental farm, and to my garden, he had the goodness to send some of it to me. In the subsequent spring (1816) I sowed it at three different periods, namely, the beginning of April, the middle of May, and the latter end of July. The first sowing ran to seed, without forming even the appearance of a head; and, as the produce of the second sowing was scarcely much better, I had little encouragement to pay attention to the plants of the last sowing. I therefore reserved only twenty of them to stand through the winter, which they all did exceedingly well; and, in the following spring, some of them produced very noble heads, one seven inches diameter, and another eight. But the general habit of the plant seemed to be to throw

out side shoots, each bearing a small head, rather than to produce an individual stem, terminating in one large head. But in whichever way the broccoli is produced, whether from side shoots or from a single stem, it is decidedly superior to every other variety of its tribe that has yet fallen under my observation.

It is probable that, in its native climate, little attention is paid to the selecting the best plants for seed. Were this duly attended to, there is no doubt but that in time it would improve in the uniformity of its growth, and possibly in other properties, but scarcely in its good quality, for that is already most excellent.

HOLLANDEN HOUSE,
TOWBRIDGE, KENT,
25th April 1818.

}

XLVIII.

On Destroying Caterpillars.

In a Letter from Mr ALEXANDER WITHERSPOON, Haddington, to LEWIS GORDON, Esq., Depute-Secretary of the Highland Society.

(Communicated by the Highland Society, and read 23d May 1815.)

I HAVE a small garden which is close to this town, of course cannot be very well aired. In it there are a few rows of gooseberry bushes. I have nothing of what can be called nicety in the management of my garden; but, being a lover of gooseberries, and knowing the depredations committed by the caterpillar, I have kept a good look out in the spring, when the buds were shooting forth, and by one means or other, although attended with much labour, kept the bushes tolerably free, although not altogether exempt from that destructive creature. At one time I was at the pains to pick off the caterpillars by the hand; at other times to strike the lower part of the branches, thereby making them spin themselves down to the ground, and then by raking and stirring the

surface of the ground, to kill them. I occasionally likewise used tobacco-liquor. I believe these are the ways mostly in repute to keep these creatures under. What I am going to communicate, will, with little labour, be found superior to these laborious methods. After last fruit-season I observed, in one of my rows of bushes, much destruction of the leaves. On taking a nearer look, I saw it was by a most numerous swarm of caterpillars, of very small size. It is when any thing is thus in excess that its peculiarities are best discovered: from appearance I conjectured these were the succeeding race to those of last spring, and likely to be the depredators in the spring ensuing; and, if so, that nature would have instructed them in some method of self-preservation. This sort of caterpillar does not appear on the bushes in winter as they did in summer. Reflecting on this subject, it therefore appeared evident, that either those creatures, in this case where I had seen them so numerous, were, by too much forwardness, an exception to the general economy, or that they were not; if the former, then they would die and fall off; and, if the latter, that they would have a retreat into which they retired during the winter; in this retreat, if easily discovered, it would be an easy matter to kill them: —to know the economy of those creatures would be, I trusted, the same as to know the cure.

By careful observation, I found that they instinctively retire to the lower parts of the bushes,

where they live through the winter in a torpid state, without food, in clusters or groups, principally under chopped leaves, which are wove or bound to the creatures, and to the branches, by a fine silken thread, which, like the spider, those creatures have the power of working from their bowels; they are likewise found bound together by the same thread, but without such covering of leaves, on the under side of the horizontal and angular branches, where the branches divide, and especially near any rough or knotty part, which serves them for shelter and covering.

I find such numbers collected in these retreats, that it appears few have died this winter (1814-15), though it is now January. Those creatures are torpid, but that seems their natural state at this time; for, upon being brought into the house, as I have done with some thousands, they became lively immediately, and would creep off, were they not confined; they seem as if they could live for a long time without food, even in this more lively state.

From what I have observed, I would infer that those creatures come forth from the egg while it is yet summer heat; that they spread over the bushes among the leaves, but being very minute, are not generally observed till near the close of the season; at which time, like the swallow, which seeks a better climate, they all move in quest of shelter and a place of safety, where they may lodge till the warm weather and tender bud invite them forth in the

spring, from which time, till they come forth flies, their changes are well known, and not important, at least not so to our present subject. What I propose is, to kill them while in their retreat, which may be at this time easily done by various means; and I have found nothing better than to besmear the parts with tar. I am certain enough of their destruction on standard bushes, but on walls there will be some difficulty, as the vermin get under loose pieces of lime and stones; however, as we are certain as to the stage they are in at this time, these can be traced out. I am, &c.

HADDINGTON, }
January 10. 1815. }

XLIX.

*Hints on Transplanting of Onions ; on Canker
in Fruit-Trees ; on Scottish Pears, &c.*

By Colonel SPENS of Craigsanquhar.

(Read 6th June 1815.)

Transplanting of Onions.—**T**HOUGH the onion and the leek may be nearly related, and though in general the mode of cultivating them, and the uses to which they are applied, are pretty similar, yet perhaps there is one essential circumstance in which they differ very materially, and which may require to be taken into consideration. The onion is cultivated with the intention of ripening the bulb so thoroughly, that, when taken up in autumn, it may be stored, and preserved in a sound state for many months. The leek, on the contrary, transplanted about the month of June, from a seed-bed, usually remains in the ground always, and is only taken up when wanted.

Mr Macdonald, gardener to his Grace the Duke of Buccleuch and Queensbery, has given the Society satisfactory proofs, very creditable to himself,

that, in some stations at least, the onion may be transplanted from seed-beds, sown in spring, with very great advantage. Doubts, however, may be entertained, how far this mode of cultivating the onion may answer in general, from the frequent difficulty of getting the seed sown sufficiently early in the spring, to admit of the plants being put out, so as to afford the reasonable hope of bringing the bulb to full maturity that season.

At Craigsanquhar, the onion-seed is sown as early in the spring as the state of the weather and ground will permit *, and yet though I have had it much at heart ever since I saw Mr Macdonald's observations, I have never been able, according to my gardener's ideas, to get it in soon enough to allow us to make the experiment with any prospect of success, till the present year (1814).

It is true that we are considerably above the level of the sea, from which, in a direct line, we may be at least three, if not four, miles distant ; that, with us, vegetation during the spring does not proceed rapidly ; and that none of our garden crops are early, though in general sure and abundant ; and that, agreeably to the opinion of my gardener, the onions from the seed-bed would not be large enough to

* In 1812 it was sown 13th February ; in 1813, 3d March ; in 1814, 22d February, and in 1815, 28th February. On the 27th May 1815 we transplanted onions from the beds sown on the 28th of February. The season was very favourable ; and the onions grew to a very large size.

transplant before the end of May, or perhaps the beginning of June.

However, that Mr Macdonald's mode ought to be attempted whenever there is a fair chance of success, may very readily be admitted; and if difficulties and objections are here started with respect to the probability of its answering in general in Scotland, they are only brought forward with the hope that they may be duly considered and removed.

Mr Macdonald has it in his power to transplant his onions in the end of April or beginning of May,* and this, too, in a climate reckoned, I believe, good and early; but it may be questioned how far the experiment would prove successful in places every way less favourably situated, and where the plants could not be put out till towards the end of May, or beginning of June. Perhaps, however, they are sooner large enough to transplant than people in general may be aware of; upon which point Mr Macdonald will be able to give satisfactory information.

Should it be found that Mr Macdonald's mode will not answer in general, might not the Society, upon due consideration, recommend the one detailed by Mr Knight, in the Transactions of the Horticultural Society of London, page 157, volume 1st, which removes the objections here stated †?

* Mr Macdonald generally raises a few potfuls of seedling onions in a stove or forcing-house, so as to have them sufficiently early for planting out.—SEC.

† Mr Knight remarks, that "the onion, in the South of Europe,

What is termed the *Winter Onion*, usually sown in August, though it does not attain a very large size, yet, if allowed to remain in the ground until the crop sown in spring is taken up, ripens so well, that it keeps much better and longer, and is therefore very useful.

acquires a much larger size during the long and warm summers of Spain and Portugal, in a single season, than in the colder climate of England; but, under the following mode of culture, which I have long practised, two summers in England produce nearly the effect of one in Spain or Portugal, and the onion assumes nearly the form and size of those thence imported.—Seeds of the Spanish or Portugal Onion are sown at the usual period in the spring, very thickly, and in poor soil; generally under the shade of a fruit tree; and in such situations the bulbs in the autumn are rarely found much to exceed the size of a large pea. These are then taken from the ground, and preserved till the succeeding spring, when they are planted at equal distances from each other, and they afford plants which differ from those raised immediately from seed only in possessing much greater strength and vigour, owing to the quantity of previously generated sap being much greater in the bulb, than in the seed. The bulbs, thus raised, often exceed considerably five inches in diameter, and being more mature, they are with more certainty preserved, in a state of perfect soundness, through the winter, than those raised from seed in a single season. The same effects are, in some measure, produced by sowing the seeds in August, as is often done; but the crops often perish during the winter, and the ground becomes compressed and soddened (to use an antiquated term) by the winter rains; and I have, in consequence, always found that any given weight of this plant may be obtained, with less expense to the grower, by the mode of culture I recommend, than by any other which I have seen practised.”

The Society has properly enough offered prizes for the best mode of cultivating the onion; but in this many people are more successful than in preserving the crop after it is taken up. It might therefore prove beneficial, were prizes also offered for the best account of the preparatory means to be used a short time previous to taking up the crop, and after it is out of the ground, so as to put it in a proper state, to remain in store, without spoiling.

Canker in Fruit-Trees.—The increasing mischief produced by canker, is a subject to which I take the liberty of requesting the particular attention of the Society, from the conviction of its great importance. I venture to suggest the examination and inspection of gardens, in which it might be found very prevalent, by committees appointed for that special purpose. This disease is, I believe, frequently mentioned by authors, yet I do not know that it has been taken notice of in any work exclusively devoted to the subject, except, perhaps, in a Treatise by Mr Patrick Lyon, on the Barrenness of Fruit-Trees, in which he generally ascribes it to their being bark-bound, though sometimes also to insects, and to superabundant blossoms. To collect, therefore, under one view, all that may have been written upon this disease by authors of merit, in order to endeavour to ascertain all the causes producing it, and to form upon this knowledge some regular system of preven-

tion or cure, founded on rational principles, might lead to good consequences. I conceive it an object of the most serious importance, and hope that it may engage the attention, and call forth the observations of men of science and of experience.

Speaking of the varieties of the apple-tree, which have been long cultivated in England, Mr Knight, among other things, says,—“ The canker, however, which constitutes their most fatal disease, often arises from other causes. It is always found in those varieties which have been long in cultivation, and in these it annually becomes more destructive, and evidently arises from the age of the variety; but it often appears hereditary. A gravelly or wet soil, a cold preceding summer, or a high exposed situation, add much to its virulence. It is most fatal to young free-growing trees of old varieties; and I have often seen the strong shoots of these totally destroyed by it, when the old trees growing in the same orchard, and from which the grafts had been taken, were nearly free from the disease. The latter had ceased to grow larger, but continued to bear well, not being very old kinds of fruit. The young stocks, by affording the grafts a preternatural abundance of nourishment, seemed, in this instance, to have brought on the disease; and I have always found, that transplanting, or a heavy crop of fruit, which checked the growth of the tree, diminished its disposition to canker. In middle-aged trees of very old kinds, a succession of young shoots is annually produced by

the vigour of the stock, and destroyed again in the succeeding winter; the quantity of fruit these produce is in consequence very small. In this disease something more than a mere extinction of vegetable life appears to take place. The internal bark bears marks of something similar to erosion, and this I believed formerly to be the original seat of the disease; but subsequent observation has satisfied me that canker is a disease of the wood, and not of the bark. It does not appear to me to be even a primary or merely local disease, but to arise from the morbid habit of the plant, and to be incurable by any topical application."

If canker (as perhaps it often may) proceeds from insects, or from the trees being bark-bound, Mr Lyon's cure, the removing of the outer bark, may probably prove effectual. I have tried this operation on six different standard trees, and can at least say, that hitherto they have not suffered by it, as was apprehended. But as these trees had not arrived at a bearing state, my experiment cannot be reckoned complete. I freely confess, that when I first read Mr Lyon's book, I was apprehensive that the remedy proposed by him was likely to prove as fatal as the disease; but I conquered my prejudices, and determined to make the experiment; and hitherto I certainly have no reason to repent my having tried it;—on the contrary, I am inclined to believe, that it will often do good, and think that I have had already encouragement to persevere in it,

and would therefore recommend the attempt to others. After carefully reading Mr Lyon's treatise, I perused other books on fruit-trees, in the hope that I might meet with remarks in favour of his mode, and I do not think I have been altogether disappointed.

Mr Bucknall, in "The Orchardist," remarks :—
"The bark of trees, properly considered, consists of three divisions; the outer rough, the middle soft and spongy, the inner a whitish rind, being that which joins the bark to the wood; and this last is supposed to contain the liquid sap. It is constantly observed, that, when the stem of the tree grows too fast for the bark, it causes blotches and lacerations; which evil is properly avoided, by scoring the bark with a sharp knife; but care should be taken not to cut through the whitish rind before mentioned; for that heals very difficultly, generally ulcerates, and by being cut through, gives the insects an opportunity of getting between the wood and the bark, where they are very destructive."

Scoring the bark, no doubt, frequently does good. I should, however, apprehend, that where Mr Lyon's mode can be followed, it will prove more effectual, both in removing the stricture of the bark, and in depriving insects of shelter to lodge in.

Mr Knight says,—“When old trees are to be re-grafted, the scions of a very young and hardy variety, of extremely vigorous growth, should be selected; and the grafts should be inserted in the large

branches, at some distance from the trunk ; and never, where it can be avoided, in the principal stem itself. Large scions should be used ; for these take a deeper and firmer hold of the stock than the small. *The thick covering of lifeless external bark, should, at the same time, or in the succeeding winter, be totally pared off, care being taken that the internal bark be not any where cut through.* The effects of this operation will be found extremely beneficial to the tree in its future growth."

" In an old tree," he adds, " which has a thick covering of rigid unexpandible bark, the descent of the sap must be greatly impeded in its passage ; but nature is ever full of resources and expedients ; and the motion given to the trunk and branches by the winds, evidently tends, like the voluntary motion of the limbs of animals, to accelerate that circulation which it does not create. This motion is wholly lost by the grafted tree, when it has been deprived of its branches ; the sap, in consequence, stagnates under the rigid cincture of the external bark, and the death of the tree is the natural consequence. The growth in the trunks of some very old trees, which had been grafted five years, and were deprived of their external bark in the winter of 1801, was perfectly astonishing in the succeeding season, and exceeded that of the five preceding years in the aggregate."

If the disease be certainly prevalent in the old varieties of trees long cultivated in Britain, those

kinds should be proscribed, because, with respect to them, the evil is past remedy; and every exertion should be persevered in to raise and introduce new sorts from seed or otherwise. When there is reason to suppose, from certain circumstances, that it proceeds from other causes, experiments should be instituted applicable to the particular case; and the result be recorded with correctness. Our late secretary, Mr Nicol, says,—“ If there be any specific for the cure of the canker, other than the preparation of a good and kindly soil, lying on a comfortable bottom, (see the section on soils,) it is this unctiōn, (soft soap, 2 lb.; flowers of sulphur, 2 lb.; leaf, or roll tobacco, 2 lb.; nux vomica, four ounces; and turpentine an English gill, boiled in eight gallons of soft or river water to six; to be used milk-warm), as it contains the two ingredients thought most efficacious for its destruction, viz. soap and sulphur.”

“ In pruning, the medication,” says Mr Bucknall, (half an ounce of corrosive sublimate reduced to fine powder, and dissolved in a glassful of spirits, or the same quantity of spirit of hartshorn, or of sal ammoniac, put into a three-pint earthen pipkin, to be filled by degrees with common tar, and the ingredients properly mixed and incorporated) “ ought never to be omitted; for, from experience, the mercury is found to be so strongly operative in removing the baneful effects of canker in the more delicate fruit-trees, that it must be presumed to enter into the

economy of the plant, giving a smoothness to the bark, and freeness of growth : proofs of which will be produced to the Society for the Encouragement of Arts, Manufactures, and Commerce, in a few years, by persons who have attentively considered the subject.”

I have seen it mentioned, that Dr Darwin recommended a mixture of white lead and boiled oil, with the addition of sublimate of mercury, as a useful remedy ; but the proportions of these different ingredients were not stated, and I am not in possession of his works.

Several papers on the canker have been furnished by members of our Society : By Mr David Weighton, gardener, Melville House, Fyfe, p. 131 ; Mr James Smith, gardener at Ormiston Hall, p. 221 ; Mr James Smith of Glasgow, p. 333 ; and by Mr Edward Sang, nurseryman, Kirkcaldy, p. 336 of our Memoirs, Vol. I.

Various are the causes said to bring on this desolating disease. Bad or wet soil and subsoil,—exposure to cold bleak winds, in high situations particularly,—stricture of the bark,—frost in spring, checking the circulation of the sap,—external injuries of different kinds,—insects lodging in the cracks, and under the old bark,—the infirmities of decrepid old age, in those varieties long cultivated in Britain,—improper stocks, or improper grafting. Though others seem to be of a different opinion, yet Mr Knight thinks, that no topical application

will do any good, and that the disease is not of the bark, but of the wood ; and I am inclined to believe that this may frequently be the case ; for on removing cankered branches, I have often remarked, that the very heart was infected and discoloured, and the wood under all the three different barks rotten or diseased ; and that it often proceeds from the infirmities of decrepid old age, in those varieties long cultivated in this island, I am also convinced of, from its being so very destructive to young trees in new gardens, in many of which it is very prevalent, where these old kinds are found.

I am sensible that I have not been able to offer any information, or any thing new on the subject of this most destructive discouraging malady, which often destroys the hopes of the horticulturist in their very beginning ; but having, in many places, witnessed its ravages, I have wished, in a particular manner, to call the attention of the Society to it, under the impression that it is of the utmost moment, meriting, from its importance, the most serious consideration.

Probably it may be difficult for the Society to fall upon any more general mode of promoting the views of the institution than by offering prizes for the best articles, of different kinds, produced in competition. Yet it certainly may frequently happen, that gardeners may, in this manner, obtain premiums for certain fruits, vegetables, and flowers owing to a favoured soil and situation, or

from paying more than ordinary attention to the articles which they mean to produce, when, perhaps, at the same time, neither remarkable skill nor attention are to be discovered in the general arrangement of their gardens*.

In regard to *pears* we ought to correct a common error, of attempting the finer, more delicate sorts, where they never were intended to be. "Our regard to truth (says Dr Gibson) obliges us to declare, that in cold and bad seasons several pears, of French extract, do not acquire their proper degree of perfection, though those that are proper to Scotland become perfectly good. Winter thorns, ambrets, and l'Eschasseries, are, in some years, good for little; when briar-bushes, swans' eggs, and auchans, are excellent in their kinds."

"In Scotland, pear trees generally thrive and bear well. We have many kinds unknown to our neighbours, and even to our nurserymen. What folly is it to send to England or France for pear trees, when our own kinds equal, if not excel, their choicest ones in goodness? I know that, in opposition to the above, it is alleged by several of our planters, that our best fruits are only English and French kinds disguised under Scots names. This is true with regard to a few of them. I thought it

* The Society has, for several years past, annually offered a medal for the best communication on those diseases of fruit trees generally denominated *Canker*.—SEC.

more generally true than I find it on experience ; and if these gentlemen will make a careful scrutiny of the kinds as I have done, and compare them with the fruit that are described in the English and French lists of pears, they will be convinced that many of our pears are originally Scots kinds."

It is much to be regretted that Dr Gibson did not particularly name and describe all the valuable pears which he reckoned Scotch, and certainly it is a pity if they cannot be recovered, more especially if they were of the winter kind, as those which he does describe were. He wrote from his experience in Clydesdale, where the Society might circulate such queries, "What are the different kinds of winter pears cultivated in your orchard? are they sure and great bearers?" &c.

At first, and for several years, I had my best wall covered with peach and nectarine trees, but on finding this an unprofitable concern, I removed them and endeavoured to replace them with late French pear-trees, most highly recommended as sure and great bearers ; but in this I am likely to be disappointed, having reason to apprehend, that the nurseryman in London, to whom I applied for them, has not sent me exactly those sorts which I ordered. Though I have been anxious to try the late French pears, yet as, upon the whole, I am inclined to believe, that in general the Scotch will succeed much better, so I have given situations, on some of my best aspected walls, to the Auchans,

Briar-Bushes, Swan and Moorfowl Eggs, regretting much that I cannot add to this limited list. I know that several of the above do very well as standards, but in a bad season these might fail, when those against a wall would probably succeed. I have also in vain endeavoured to procure from London the Red Doyenné Pear, so much recommended for our northern climate in the Transactions of the Horticultural Society of London, p. 230, vol. i. and the true St Germain's, mentioned in p. 226 of the same work. The difficulty and uncertainty of procuring the kinds wanted, especially when a comparative experiment is meant to be made with them, is discouraging, and leads me to suggest to the Society the expediency of establishing a correspondence, both in London and abroad, either with institutions similar to our own, or with nurserymen of character and reputation to whom application may be made for trees or scions*.

The *Ribston Pippin*, an excellent apple, highly extolled by our late Secretary Mr Nicol, is by some

* Since the formation of the Experimental Garden at Inverleith, this difficulty has been obviated to a considerable extent. From the Garden of the Horticultural Society of London, and from the Jardin des Plantes, the Edinburgh garden has experienced the utmost liberality, grafts of all the rarer varieties of French pears having been received from these establishments. Shareholders and Members of the Horticultural Society who subscribe towards the garden, are entitled to receive plants and grafts as far as they can be spared.—EDIT.

recommended as an orchard tree, while others suspect that it will not generally answer in Scotland. I am inclined to be of this last opinion, for here hitherto standard trees of that kind, though apparently healthy, and though blossoming yearly, have never done any good, never having produced a single apple. Yet a tree of the same kind and age, planted against a wall, with a bad aspect (somewhat in the north of east), which gets very little sun, bears well, and ripens its fruit. This is a circumstance that may be worthy of remark.

P. S.—22d July 1828. There are two or three standard Ribston Pippin trees here on Paradise stocks, which for two or three years past have produced pretty well, and have ripened their fruit, though many of the branches are sadly cankered.

L.

On the Formation of a Gardener's Library.

In a Letter to the Secretary from Mr JAMES SMITH, dated
Hopetoun House Garden, 18th March 1826.

(Read 6th April 1826.)

SIR,

YOUR love of horticulture, and the interest which you have always shewn for its progress in Scotland, are a sufficient excuse for the liberty which I now take in addressing you on the subject of books connected with the science. On the general topic of a library for the Horticultural Society, it would be presumption in me to speak, especially as so many of the resident members are much better qualified than I am, and I have no doubt not less willing, to throw out any hints that may be necessary. Yet there is one point on which I feel myself entitled to say something.

A gardener's library is seldom either extensive or select. If he reads at all, he must content himself with what his limited means can procure. Of

course expensive works are out of the question ; and botanical engravings he never sees, but by chance ; yet in some respects it is important that he should see them. Some showy plants are so easily propagated, that they require only to be known to be widely diffused through our gardens, and in general the better known a plant is, the more likely it is to be preserved and cultivated. It appears to me, therefore, that the Society would advance the interests of gardening, by purchasing a selection of the best *botanical engravings*, to be exhibited on the table of the council-room, since you have now got one, for the inspection of members. The country gardener, in visiting the Experimental Garden, which he will always be eager to do, would have an opportunity of acquiring the names of plants which he might already possess, and seeing many others, which on first sight he would become desirous of having. It is well remarked by Mr Loudon, that the provincial situation of gardeners is the principal check on the cultivation of the beautiful tribes of American shrubs, which are much more common in the villas of citizens in the neighbourhood of London, than in the gardens of noblemen at a distance. The same observation may be applied to most other plants. The time of the gardener's periodical visit to town may be in winter, or when there is nothing in flower ; but the bloom of the Floras I am now recommending is permanent, and they present almost

at one glance the varied, and sometimes the casual, decorations of many summers. Of course you are much better acquainted than I am, with the utility of such works to men of science; I merely wish to point out their scarcely less utility to practical men. In proof of this you need only be referred to Dr Hooker's *Exotic Flora*. The splendour of the subjects of this excellent work connect it nearly as intimately with the flower-garden, as its accurate dissections and beautiful delineations with the science of botany.

What has now been said applies, and perhaps with greater force, to *engravings of fruits*. The botanist can discover the name of his plant from description merely; but there are no such accurate descriptions of fruit at present, and the gardener is further bewildered by local synonyms. It will indeed be the business of the Experimental Garden to effect the necessary reform in this department; and I wish it complete and speedy success. But in the mean time it is desirable to possess such works; as, among other benefits, they will contribute materially to produce the reform. Last autumn I succeeded in ripening two German apples for the first time, I believe, in this country. Being anxious to ascertain the correctness of their names, I sent some specimens to Edinburgh and London, when I was assured that I had got the genuine double Bursdorffer, but no information was received respecting

the other. I wished to have access to the *Pomona of Diel*, which you mention with commendation in your valuable *Tour*, but failed; and, indeed, from subsequent inquiries, it seems probable that there is not even one stray copy of it in Scotland.

I am not much acquainted with the book trade, but have been told that engravings of flowers and fruits do not frequently remunerate their authors. This is much to be regretted, considering their value. It is to be wished that wealthy amateurs would make a point of purchasing such publications, and the Horticultural Society could not do better than set them an example. I am not sure that any part of the money which is yearly distributed in prizes would be better bestowed.

I have to apologise for troubling you at so great length on a subject which I suppose you will think too clear to need illustration; and am, &c.

The formation of such a Library, as here recommended by our esteemed correspondent, had long been contemplated by the Society. A foundation has been laid for it by the purchase of Bradshaw's *Pomologia Britannica*, Sinclair's *Hortus Gramineus Woburnensis*, and some other works. There has lately been added to the Library a set of Curtis's *Botanical Magazine*, in 40 volumes; and the continuation of this valuable Work by Dr Hooker,—the *Botanical Register*, by Mr Lindley,—the *Pomolo-*

gical Magazine, under the direction of the leading members of the London Horticultural Society;—the British Flower Garden, the Flora Australasica, and the Florist's Guide, by Mr Sweet, are received monthly, as published, and lie for inspection of members on the table in the Council-Room at the Experimental Garden.

Several excellent Horticultural Works have been presented to the Library by members of the Society. Among these may be mentioned, Noisette's *Jardin Fruitier*, 3 vols. 4to., with Plates; Hitt on *Fruit-Trees*; Lawrence's *Clergyman's Recreation*, &c.

Members are respectfully reminded, that they will very effectually promote the object in view, by presenting to the Library such spare copies of horticultural and botanical works as they happen to possess, or which they are willing to part with.

P. N. Sec.

LI.

On the Cultivation of Peaches and Nectarines on Flued Walls; on Screening the Blossom of Wall-Trees by means of Nets and Ferns; on Saving Peas and Beans from the attacks of Mice; and, on Destroying these Vermin.

By Mr WILLIAM IRVING, Gardener to Sir John C. Swinburn, Bart. of Capheaton; communicated to the late Mr Thomas Dickson, Secretary.

(Read 14th June 1814.)



1. *On the Cultivation of Peaches and Nectarines on Flued Walls, with the aid of Canvas Screens.*—Our flued walls are built in the common way, twelve feet high, with three turns or levels, forty feet each in length, with a handsome trellis, the height of the first flue, to save the trees from being scorched by the heat of the fire: this allows a considerable deal of more fire without hurting the trees.

Our borders are composed of eighteen inches of the natural soil, which is strong clay, and eighteen

inches of light soil from the fields, over a bottom of six inches of stones and lime-rubbish, all beat and smoothed together; the manure employed is stable-dung, soot, and vegetable mould. Such are the materials that our fruit-tree borders consist of, and they do well.

I planted the trees at double thickness at first; I trained them, the one fan, and the other horizontal, alternately. Afterwards I was so pleased with the horizontal training, that I cut down the fan-trained trees, and gave space to the horizontal ones; for we thought the fruit on the horizontal trained trees was larger and better flavoured. But, after all, I prefer the fan-training, for handsome and easy regulating of the trees. As soon as a tree comes into a bearing state, it will bear in whatever position the branches are laid, providing they have proper space to ripen their wood, which they ought at all times to have.

My method of pruning is, to unnailed most of the tree, and cut out all the wood that is most worn out by last year's crop. I shorten such shoots as are wanted for new wood, and such as have not ripened their shoots to the point. All that have ripened their shoots to the point, I lay in at full length, allowing them a proper distance, which adds greatly to the health and vigour of the tree, and likewise to the size and flavour of the fruit. I then nail them all neatly to the wall, with new shreds; I save all the old shreds, and boil them, and lay them

aside for summer nailing. When all is finished, I wash the trees and walls all over with the following wash:—Two lb. flowers of sulphur, one lb. soft-soap, and a few pints soft water. Boil the mixture slowly for some time, to mix the strength of the sulphur into the liquid; take a tub (which should be kept for the purpose), fill it nearly full of soap-suds, and then put in a tolerable quantity of the boiled mixture, making all milk-warm. Beginning at the one end of the wall, wash every part of the trees and wall with a squirt, standing straight before the wall, so that the liquid may rebound on the back part of the tree, and enter the nail-holes and every crevice in the wall. It is proper to stir the liquid all the time of washing, to keep the sulphur mixed, otherwise it will settle to the bottom; this wash becomes like a varnish on the trees. As soon as the sun shines on the trees and wall, the sulphur smells so strong that it clears all insects from the trees and wall; the soap prevents the sulphur from being washed off the trees readily. I wash frequently with soft-water; and sometimes with soap-suds, but not when the trees are tender, nor when the fruit is swelling, as it would taint the fruit. The winter is the best time for washing with soap-suds.

Such is my mode of overcoming insects that breed on fruit-trees, and I am happy to state that I have had my trees inspected by several competent judges, when there was not an insect to be seen on them,

and the trees were found in a perfect state of health. The red spider does make its appearance in the time of the ripening of the fruit, but never does us much hurt. We are obliged to give over washing as soon as the fruit is swelling, the garden at Capheaton stands so high and cold.

I never see the smallest appearance of the mildew on my trees, although an old hedge, about eighteen feet north of the garden-wall, is affected every season with the mildew, and especially some crab-apple trees in it.

When the flowers begin to open, I put on the canvas, pulls it up at night, and lets its down all the day, except when the weather is wet or cold; in such weather the canvas remains all day upon the trees. I light fires every night in the evening, from the time the flower begins to open until the fruit is all stoned. I find by practice that peaches and nectarines set best in a moderate heat, with plenty of fresh air. As soon as the weather is fine, which seldom happens here before the middle of June, I remove all the covering and fire-heat. I never again light a fire, unless at the time of the fruit ripening, and then only when the weather is wet; for the sun at that season is strong, and the fire-heat stops the dew from falling on the fruit; but moderate dew adds to the flavour of it. As soon as the fruit is all off, I wash the trees with soap-suds, and if the wood is not ripened, I light fires to ripen it.

Our canvas screens are made very neatly: they are all joined together with a wall-plate at top, and another at bottom, and the rafters are all mortised into them; these rest on spikes of wood driven into the border, and the sheets are lashed to small beams at top and bottom. They are twenty feet long, draw up with pulleys, and are lashed together with small cord, which makes a handsome cover, almost as good as glass. It has been very much admired by several gentlemen, who got models from it.

2. *On Screening the Blossoms of Fruit-Trees with Nets and Fern, to save the Blossom from Frost and bleak Winds.*—About the month of September, I gather a quantity of long fern. My method of preparing it is this: I cut the fern with a knife and bind it up in handfuls with a strand of grass, taking care to lay one handful above another as flat as possible. I then lay the bundles on a dry airy loft floor, placing one bundle alongside the other, and turning them over every other day until they be dried. I then lay them up in pile, taking care that they are always kept on their flat side, otherwise they will not work neat in the covering. I provide some poles in the young plantations, dress them, and sharpen them at the thickest end; then lay them aside, until they be wanted. I furnish myself with some sheet or large-meshed nets; they are the cheapest and best for this sort of covering. As soon as the blossoms begin to ex-

pand, I place my poles about four feet apart, and eighteen inches from the wall at bottom, thrusting the sharp end into the ground, and resting the other end against the coping ; then drawing the net over them, fastens it at top to the coping, and at bottom with strands of bass, round the poles. We then begin at the under part of the net, and tuck in the fern, putting the root end in at one mesh and out at the other, with the top of the fern downwards, all in lines as if slating, as thin as merely to touch one another, but allowing them to be a little thicker or closer at the top of the wall. When the fern is all in, I hang another net over the whole, and then make all fast to the poles at different places, with strands of bass. To prevent the wind from displacing the fern, all must be done when the weather is calm ; for wind would be troublesome. This mode may appear, to some, tedious ; but those who try it will find, after a short practice, that it is an easy operation. Nothing more is wanted, until the fruit is all set, and the weather fine ; then I take off the upper net, and remove all the fern ; but I hang on the nets again for some days, to harden the trees gradually. Then, taking the opportunity of fine soft weather, we remove the whole : this ought never to be done when it is very cold, nor in broad sunshine, for, at such times, sudden exposure would hurt the trees and the young fruit. I have made use of this covering for these thirteen years past, with great success, finding it a safeguard against al-

most all sorts of unfavourable weather. When the fern is wet, it expands itself; when it dries with the sun, it contracts; so that it then makes but little shed. I now stick on the fern, and make a close cover, in a snowy night.

3. *Method of Saving Peas or Beans from the attacks of Mice.*—When the peas or beans are sown or planted, in the common way, I provide myself with a quantity of the tops, or last year's shoots of whins, which I clip off with the garden-shears: these I lay into the drills above the seed, so close, that each branchlet or shoot is touching another: I then cover the drills with a little earth, and press them gently with the foot. I next draw on the remainder of the earth with the hoe, somewhat ridge-ways. As soon as the plants make their appearance above ground, I draw a little earth over them. As the whins keep the earth open about the plants, they are the better to be thus covered over, as soon as they make their appearance. I have practised this method for fifteen years with perfect success; the mice never touching the peas or beans, seemingly from dislike to the whins. I may here remark, that it is a good method to stick peas as soon as they make their appearance above ground; for the peas are thus in less danger of being broken by the sticking, and by means of the sticks they derive some shelter from the frosts and bleak winds.

4. *Cheap Method of catching Mice.*—I have been so much distressed with that little but troublesome animal the mouse, that I have taken many methods to destroy it. At last I contrived the following mode: I placed a quantity of bell-glasses in the garden, sinking them level with the earth, and filled them half full of water. I then put a little oatmeal over the water in the glass, and also a little of the meal over the earth about the outside of the glass, to decoy them to a watery grave. This mode proved very effectual, as I daily found numbers drowned in the glasses. I was so pleased to find that I was likely to get the better of my enemies, that I placed glasses, prepared as above, all round the garden, in different places, where the mice haunted, and caught them in great quantities. The mice are bred, for the most part, on the outside of gardens, and come in for their provisions. We have found this mode so effectual and expeditious, that we have placed similar glasses in our granaries here, and we find them as effectual there as in the garden. It must be observed that, in winter, frost will freeze the water in the glasses and burst them; they must therefore be covered from the frost, but so as to allow room for the mice to go under, as they will catch best in time of frost. Before I fell on this method, the mice sometimes devoured all my cauliflower plants in the frames; they barked the wall-tress; and even spoiled broccoli in the open ground.

At this present time there is not an article troubled by them in our garden. But, in our neighbourhood, where this remedy has not been resorted to, the cauliflower plants in the frames, and carnations, lettuces, &c. &c. are very much damaged by them.

CAPHEATON, }
2d June 1814. }

LII.

Hints on the Management of the Grape-Vine, particularly in Peach-Houses; and on propagating Vines by Layers and Cuttings.

By Mr JOHN MARTIN, Gardener at Kirkton Hill. In a Letter to the Secretary.

(Read 8th March 1814.)

AS it is allowed, among gardeners, that grapevines thrive in some places better than in others, and as this depends not a little on management, I shall here give a few hints regarding my mode of treatment.

Where I was formerly head-gardener, we had two divisions, forming a range 100 feet long. Both the houses contained vines and peaches. The vines had never done well, as the peaches were preferred; but I determined to try to do justice to both. I was a little disappointed the first season, by reason of the leaves having been forced off from the vines the year before, and the plants thus weakened. I determined to do something for strengthening the plants. I prepared a compost of good light soil, rotten

leaves, cow-dung, and lime, and, having opportunity, some bullock's blood was likewise used. When I had all prepared, I removed all the old soil at the distance of five feet from the main stems outwards, very carefully moving the roots. At the length of twenty feet, I found the roots among unkind gravelly stuff. I put in the compost already described, and applied it all around the roots with the fingers. I had in return next season from sixty to seventy bunches of grapes on the rafters, without shading the peaches in any degree.

I must remark here, that vines do not answer in a small peach-house; while both may do well where the house is large.

There is another evil that attends vines in a peach-house; the taking off the leaves of the vines to let in sun-light to ripen the peaches, and to give them a better flavour. I always shed the leaves below the fruit, and this practice has always given me good satisfaction for the next crop. I never take off the leaves after the crop is gathered, but allow them to drop off of their own accord.

I water the border thrice a week with cow-urine and soap-suds, for about a month before I begin to force, and I apply the liquid not in small quantities. I find that it affords great nourishment, and causes the production of good and large bunches.

Any one that is curious to have vines in pots full grown, should, at the time of pruning, take the stem through the hole in the bottom of the pot, and

lay the rest of the vine from the bottom of the pot in the ground. They thus shoot much sooner. For such purposes, I take the old shoots that are to be cut out that season. For the pots I use the same compost as for the border. I always keep rotten dung about the pots, as it makes the vines strike much sooner, than keeping the pots dry. I have had twenty-six good bunches in a pot, and could have had more but for thinning. When the fruit is at maturity, I cut the old branch by the bottom of the pot, and remove the plant at pleasure for ornament.

I have tried different times whether layers or cuttings would become the best plants, and I find the cuttings always to have the preference. The layers I find stand stationary, in a manner, for two years. The reason for that is, they have more head than root; the scanty root cannot make such a large head push regularly, and the plant must strike more roots before it can push to perfection. Time is lost and expence incurred. Let no gentleman think of planting his grape-house with layers: I have often seen the ordinary vines that were struck in a nursery turn to the best account.

My method of preparing young vines for a house, if they are in pots, is this: I take them and shift them, and cut some of the old roots from them. For soil, I use a little black light-earth, and rotten leaves, that have been rotten below dung for a year, with some cow-dung, and a small quantity of lime,

all well mixed together. After they are shifted, I let them stand for three weeks in a shed; and in the course of that time I prepare a hot-bed, made up on purpose for them, with tan and horse-dung, as the tan keeps the steadiest heat, and one foot of rotten leaves on the top of the bed, for plunging the pots among the rotten leaves to the brim. When they are to be planted in any old house, I take out the old soil where the former plants were, and make it up with the new soil already described. When the shoots come to the length of two feet, those that were in the hot-bed are planted in the border, not too deep. I prefer planting them in the month of May. This is the best season, as the plants never get a check by removing them, and they push faster than at any other time.

I have found that the vines, when not deep planted, do best, as they search for the soil themselves.

I have often taken notice, that, in some sorts of vines, the foliage turns brown, just as if it had got a little frost. Such vines are generally on a clay soil, or on a bottom that does not let the roots push freely, so causing a stagnation of the sap.

KIRKTON HILL, }
4th March 1814. }

LIII.

*Notice of a Hawthorn Hedge, damaged by *Æcidium laceratum*.*

In a Letter to the Secretary from Mr WILLIAM DON, Hull.

(*Read 14th June 1814.*)

SIR,

I BEG leave to lay before the Caledonian Horticultural Society some observations on a disease which has, during the last year, made its appearance on part of the young hawthorn plants composing the hedge which, on three sides, surrounds the Hull Botanic Garden.

The hedge was planted in February 1812, with healthy quick-wood, that had been two years in the seed-bed and two years transplanted. In the summer of the same year, I observed, on one or two of the shoots, a singular brown swelling; but at that time I paid no particular attention to the subject. Last year, however, towards the latter end of June, one of the subscribers to the garden brought me several similar protuberances, which had caught the observation of a little girl who was walking with him; and,

on examination, we found that the whole hedge, for about a hundred yards in length, on the west side of the garden, was infested with similar protuberances, which distorted almost every shoot; and that, apparently in consequence of the disease, the growth of the hedge was in that part greatly stunted, and the infected plants had a very sickly appearance.

Those protuberances, for the most part, occur in the middle of a young shoot, but sometimes towards the end, and vary in number from one to three, or more, on each shoot. Frequently, even the leaves are similarly affected. Their most usual shape is oval; but they are often singularly curled and distorted. In size they vary from that of a bean to that of a walnut. Exteriorly they are sometimes smooth, but commonly present a brown shaggy appearance, which, when examined with a magnifying glass, is found to arise from numerous minute and thickly set orifices, each surrounded with many leaves, and containing a brown powder, which at one time was so abundant as to make a visible cloud when the hedge was shaken. Interiorly they are solid, but of a less consistent and more brittle substance than the rest of the shoot, without any appearance of being inhabited by insects of any description.

With respect to the nature of these protuberances, there seemed every reason, from the brown powder, to believe them to be fungi of some kind; and I am informed by the gentleman above alluded to, that, having sent specimens to Mr Sowerby, that celebra-

ted artist and botanist stated them to be *Æcidium laceratum* of his *English Fungi*, table 318, adding, that “*Æ. cancellatum*, (t. 409. of the same work), attacks pear-trees, and often prevents valuable crops.”

Though I have made diligent inquiry, I have not met with any one who has before observed the disease in this neighbourhood; and, what is remarkable, though the quick-wood was all from the same nursery, and planted at the same time, it is entirely confined to the hedge on the west side of the garden, and chiefly to about 100 yards in the middle of it. On the east and south hedge, I have never discovered a single protuberance.

Any disease attacking a plant so important both to the agriculturist and the horticulturist, as the hawthorn, is deserving attention; and that the one in question may become of serious moment, is proved both by the dwarfish growth of the hedge, which it has attacked, and the fact that, at present, every one of the shoots seems to have died down to the lowest protuberance.

BOTANIC-GARDEN, HULL, }
21st February 1814. }

LIV.

*On the Curl in Potato, and on the transplanting
of Onions.*

By MR PETER LOWE, Gardener at Torwoodlee.

(*Read March 8. 1815.*)

Curl Disease.—**H**AVING read the Memoirs of the Horticultural Society as to the curl in potatoes, and differing from some that have written on that subject, I beg leave to offer my opinion, if it is of any use to be known or thought worth notice.

Potatoes that are intended for seed, I recommend to keep free from wet or damp, either in house or in pits: I prefer keeping them in pits, by laying them just on the surface of the ground, (it being smoothed before), laying them as steep and high as possible they will lie by building them carefully: put a good covering of straw, or of ferns, such as are usually in the country called *brakens*, and above

sufficient earth to keep out the frost ; beating all well together with the back of a spade or shovel. The pits ought to be looked after to see they do not crack on the top, and to notice that mice or rats do not make holes so as to let in wet. This method I prefer to housing potatoes. I do not approve of either putting long dung or the haulm or shaws of potatoes on the pit, after it is finished ; rather add more earth ; because the other sort of covering admits wet, and stops the seeing of mice or rat holes.

When the potatoes are taken out of the pits, if they are wet, separate them from those that are dry ; I mean if intended for seed, for those that are wet are, I think, more apt to curl.

Generally at the root end of the potato, or what Mr Thomas Dickson calls the waxy end, almost close by the feeding-string, there is an eye which cut by itself mostly produces a curl, unless it has another eye in the cut or set, which other eye generally springs first, and stops the former from growing ; except in the foresaid cut, I recommend only one eye. By attention to this, this season I could have shewn a whole break, and scarcely a curl in the whole break : they were early potatoes, which are more given to curl than the late sorts.

I differ from my friend Mr Dickson ; for I maintain that the ripe end is not given to curl ; whereas the root or waxy end, as he names it, is the only part of the potato that is apt to curl, unless it was a curl potato before.

I cannot help differing from Mr Crichton as to the advantage of having potatoes long cut before planting. This last spring I planted some three weeks after being cut, and knew no difference between them and those that were planted sooner after being cut. I prefer them being cut two or three days before they are planted, so that the cut may gather a crust on it: in that case it is not so apt to rot in the ground if it is exposed to wet, or if a wet spring follow after the potatoes are planted.

In taking potatoes intended for seed out of the ground, particular care should be taken to separate those affected with curl. A person that is acquainted with potatoes may easily distinguish the one from the other, although the shaw or stem should be withered. The curled ones are of a much darker yellow, small, of a crabbed look, and few at a stem.

I do not say that the foresaid hints will afford a perfect cure or a constant preventive; I only say they may prove a mean towards it.

As to getting of seed from cold or late places for a change, this is not thought of in the part of the country I reside in. We prefer seed from a lower climate, such as Melrose, or that quarter; but in particular from Langholm or thereabouts; but seldom or never from the upper part of Galawater. This preference must be founded in experience of the advantage*.

* Since this paper was originally written, the practice has, in some measure, altered. Last year we got our seed potatoes from

Too deep planting, I am convinced, promotes the curl. Curled plants I have generally found to have been set nine or ten inches below ground, instead of four or five.

I have found that wet in winter encouraged the curl. About ten years ago, I had a particular kind of potato that I wished for seed. I had them in a house secure from frost, where, however, there were some rabbits which wet them very much; I believe there was more than the half curled. Here, however, the wet was of a peculiar nature. Thereafter for two or three seasons I had them pitted, (I mean the seed-stock to be planted out for the use of my own family), a short distance from my house, where there had been sticks laid up for fuel for a number of years; the rubbish or small half rotten twigs were good for keeping off the frost, but readily admitted wet: my potatoes were more affected with curl than those of my neighbours, for all the care I took in selecting the seed.

For some years I have got them pitted in the open land along with Mr Pringle's; and now I am as free of the disorder as any in the place.

Besides, in the seed I kept of early ones for the garden, whenever they were wet, I observed they were more given to curl than those that were taken dry out of the pit. So now I make it my particu-

Caddenhead, a sheep-farm west of Galawater, much of it cold and mossy soil. Sept. 1828.—P. L.

lar care to keep them as dry through winter as possible.

Transplanting of Onions.—In the end of July 1812, I sowed what is termed by gardeners winter onions. The following spring they were too thick. In April 1813, I planted out a good part of them : they succeeded well ; they were not indeed large, but a good middle-sized keeping onion. They kept through the year much better than any other I had. A sample of them is sent along with this, and it is now December 1814. I am apt to think that treating onions so, would be a more certain method than the usual practice.

TORWOODLEE, }
Dec. 16. 1814. }

LV.

Some Account of the Fruits grown in Gourdiehill Orchard, Carse of Gowrie, with Remarks.

In a Letter from PATRICK MATTHEW, Esq. to the Secretary, dated 3d December 1827.

DEAR SIR,

WHEN I saw you some weeks ago at Canonmills, I felt most grateful for your attentions. You having expressed a wish for grafts of the best Carse of Gowrie fruits, for the Experimental Garden, I thought I would repay my obligations most acceptably, and shew the respect I felt towards the establishment, by sending specimens of our best keeping apples, accompanied with short notices of their quality, &c., from which you will better be enabled to judge what sorts you would require for the garden. I have, therefore, sent a selection of our best Carse of Gowrie fruits. Grafts of any of them I shall afterwards send as you may desire*.

I have succeeded in making out the local names

* A considerable collection of grafts of the most select kinds has accordingly been received at the Experimental Garden, Inverleith.—P. N., *Sec.*

of most of the fruits, and their synonymes ; but a portion still remains (a considerable part of which belongs exclusively to my own orchard) for which no names could be traced. I have, therefore, in such cases, been necessitated, for the convenience of reference, to make drafts on my own invention.

When I shewed this selection to my friend Mr Gorrie, he told me that your Society give honorary prizes for what they deem best, and that he thought some of these stood a chance of being reckoned so. I have, therefore, made one parcel of six sorts, "not generally known;" and another for twelve "best (estimating by value of production) orchard apples," for competition. If you think them worth being presented for your shew on 6th December, please do me the favour to forward them to the meeting on that day*.

I have examined a considerable number of varieties of Winter Pears peculiar to this district ; but they are, with a very few exceptions, of such bad quality that I did not think they merited to be more generally known, at least for being used raw, or in their natural state. I present several of the more interesting.

* In the year 1827, the Society's Silver Medal having been offered for the best six sorts of Orchard Apples, not generally known in Scotland ; the Medal was (7th December 1827) awarded to Mr Matthew for the six first mentioned, viz. Ben Lomond, White Fulwood, Fair Circassian, Bonnie Bride, Green Virgin, and Scottish Chief ; the specimens being beautiful, and the quality proving excellent.—P. N. Sec.

I also forward to you two supposed specimens of modification of apples, resulting from the mixture of juices from the stock and graft. No. 75 is a modification of No. 74, the Tower of Glammis; and No. 76 a modification of the Early Gowrie *, which it much resembles, but is a month later in ripening. These supposed varieties are produced by springing shoots from the point of union, or near it, of the stock and graft in old trees, where time may have operated to mingle the qualities of both. This principle of forming new varieties and hybrids by the commixing of the sap, seems applicable to plants in general, possibly as much so as the known process of mixing the germs of different varieties in the flower, *i. e.* applying the pollen of one sort to the stigma of another sort. These two unbegotten varieties have nothing interesting but their origin, only a peculiar luxuriance of vegetation and backwardness to come to flower-buds, when continued by grafting.

After leaving you, I visited Clydesdale. The cheapness of ground, and genialness of climate there, overbalance the expence of carriage to Edinburgh †. Clydesdale is but an infant settlement of fruit-trees compared with the Carse of Gowrie; and, from its

* Specimens were sent to the Society, and, from the mixed nature of the resemblance of the apples taken from the upper and lower parts of the same tree, there appeared a probability of their being modifications.—P. N. *Sec.*

† This alludes to a proposed large orchard, near Edinburgh, for its supply.

modernness, has generally a more profitable selection, but not nearly the number of varieties. I would recommend to your notice these varieties of Clydesdale: Tam Montgomery, Early Marigold, Transparent, Golden Munday, Craigton Pippin, Bankie's Apple, Sovereign, Rock Apple or Fletcher's Seedling, Early Fulwood; and of late fruit, Ayrshire Pippin, Red Cluster, Dunside, Ayrshire Carpandy.—Of Pears, Pear-Iron, Winter Bergamot, Vicar, Grey Honey.—Of the Apples, I consider the Red Cluster as the most valuable; of the Pears, the Pear-Iron. Clydesdale is a diluvial country of gravel, sand, and till, with an admixture of fragments of coal; in its general constitution much resembling some of our Highland valleys, having only in addition the coaly fragments, and more alumina. Diluvial gravel is most interesting to the geologist or miner, giving indices of every mineral within the field of its collection.

LIST OF SEVENTY-SEVEN SORTS OF WINTER APPLES, AND FIVE SORTS OF WINTER PEARS, CULTIVATED, WITH TWO OR THREE EXCEPTIONS, IN THE ORCHARD AT GOURDIE-HILL, CARSE OF GOWRIE; THE WHOLE FROM STANDARD TREES.

APPLES.

1. *Ben Lomond*, fruit of good quality; tree bears steadily, has long slender twigs, is of middle size, leaves large, and of uncommon figure; a rare variety.

2. *White Fulwood*, fruit of most excellent quality, especially the coloured variety; keeps well, tree middle size, with a large leaf: sometimes the points of the branches die; bears steadily fair crops, but not heavy loads.
3. *Fair Circassian*, tree a good bearer, pretty large and healthy; fruit keeps well, and of very good quality when kept; a rare variety.
4. *Bonnie Bride*, tree a good bearer, middle size, and healthy; fruit of excellent quality; a rare variety.
5. *Green Virgin*, tree an excellent bearer; bears when young; fruit keeps well, is of good quality, and of a fine yellow when kept. This is one of the most valuable apples in the Carse of Gowrie, but known only in Gourdiehill orchard; tree healthy, middle sized.
6. *Scottish Chief*, tree an excellent bearer, healthy, middle sized; branches very pendent; fruit of good quality. I believe only at Gourdiehill.
7. *Winter Redstreak*, tree a good bearer, middle size, and healthy; most excellent and valuable fruit. This is the *Camb'nethan Pippin* of Clydesdale, and is sometimes named *Watch Apple*. There are several subvarieties of this fruit.
8. *Green Langlast*, tree a most excellent bearer; fruit of capital quality when kept; tree middle size, bears young. The *Green Virgin*, the *Standard*, and *Green Langlast*, may be reckoned the most profitable winter apples in this district.
9. *Green Fulwood*, tree a good bearer; bears young; middle sized; points of twig apt to die in old trees; fruit of good quality, and will keep exposed to the air till July without a wrinkle.
10. *Monstrous Leadington* or *Green Codlin*, tree a good bearer, healthy, and rather large; fruit keeps well, and is very valuable for kitchen use. Not a common variety.
11. *Red Wine*, tree a good bearer, middle sized, becomes much knotted when old, and rather unhealthy; a very valuable market apple.

12. *Scotsman*, tree an excellent bearer, and bears when young ; fruit of good quality, keeps well ; a rare variety.
13. *Standard*, tree a most excellent bearer, and bears young ; fruit much esteemed, gets a beautiful golden colour when well ripened ; tree middle sized, with very black wood, woolly leaves, and extremely thick bark ; a rare variety.
14. *Flat Anderson*, tree an excellent bearer ; fruit of capital quality ; tree middle size and healthy ; rare ; only one tree at Gourdiehill.
15. *Baudrons*, tree an excellent bearer ; fruit keeps well, and is of good quality, with much acid, excellent for tarts ; tree middle size, and healthy ; rare, and, it is believed, only at Gourdiehill.
16. *Fame*, not a common variety.
17. *Winter Courtpendu*, fruit of good quality, and very handsome ; tree bears well, and is of middle size.
18. *Red Fulwood*, large, spreading, graceful tree, full of leaf and vigour, the giant of the Carse of Gowrie orchards ; bears very great loads of fruit every second year ; fruit beautiful.
19. *Wood Nymph*, a very large fruit.
20. *Wallace Wight*, quality good, keeps well ; tree rare in the Carse.
21. *Daisy*, very beautiful small sweet fruit ; not common.
22. *Macleane*, tree gets diseased when old ; requires to be planted in ground new to fruit trees ; fruit keeps well, of excellent quality, and weighs extremely heavy.
23. *Margil*, tree a shy bearer, but most excellent fruit. Would need a wall. Sometimes called *Small Ribston*.
24. *Redcoat*, a rare sort ; very pretty.
25. *Black Bess* or *Fox-Whelp*, tree a good bearer ; fruit keeps very long.
26. *Lady Finger*, sometimes called *Paradise Pippin*, the *Egg Apple* of Clydesdale ; tree bears well when in high culture ; fruit of good quality, very pretty, and keeps well.
27. *Sweet Pintstoup*, tree a good bearer, but not common.

28. *Jack Cade*, fruit very acid, would do for cider, or for giving pungency to tarts.
29. *Red Aisle*, a rare kind ; inferior bearer, but pretty.
30. *My Joe Janet*, tree a good bearer ; fruit of fine quality.
31. *White Bogmiln*, a rare sort ; large, fair quality.
32. *Serjeant*, tree beautiful, upright growing, and large, not common.
33. *Rose Apple*, tree a good bearer ; a valuable variety.
34. *Friar Grey*, a rare sort.
35. *White Wine*, tree a good bearer.
36. *Sweet Russet*, not usual.
37. *Ribston*, tree a shy bearer, and unhealthy ; fruit excellent. Would need a wall here, or espalier training.
38. *King Robert*, tree a good bearer, but not common.
39. *Grey Leadington*, tree a fair bearer ; fruit of excellent quality.
40. *Scarlet Golden Pippin*, fruit of very best quality ; tree bears moderately well.
41. *Red Langlast*, tree a great bearer, middle sized ; good quality of fruit.
42. *Tulip*, tree a good bearer ; only one tree known in the Carse.
43. *Rosalind*, only one tree known, and it is very old.
44. *Clouded Scarlet*, a rare sort, very beautiful ; tree bears well.
45. *Golden Rennet* or *Courtpendu*, tree a moderate bearer.
46. *Paradise Apple* or *Lemon Pippin*, an excellent fruit, keeps well ; tree is productive only in a moist rich soil.
47. *Gourdiehill Scarlet*, tree bears moderately ; a rare sort.
48. *Pow Captain*, tree a good bearer ; fruit of good quality ; sometimes named *La Fameuse*.
49. *Winter Scarlet*, tree a good bearer ; fruit keeps well ; not common.
50. *Bogmiln Favourite*, fruit of excellent quality ; not common.
51. *Rival*, excellent quality, keeps well ; good bearer.
52. *Miss Baillie*, a very sweet apple.
53. *Shagreen*, tree an excellent bearer ; fruit keeps well.

54. *Winter Ruby*, tree bears well; not common.
55. *Hebe*, tree a good bearer.
56. *Maiden*, tree an excellent bearer; fruit very acid, but one of the best kitchen apples that grows; does not keep well. A seedling raised by Mr Brown of Perth.
57. *Scarlet Leadington*.
58. *Twin Wine*, tree a good bearer; fruit very beautiful, and sometimes twined together.
59. *Maggy Duncan*, tree an excellent bearer; a valuable orchard apple, though not commonly cultivated; fruit very sweet.
60. *St Patrick*, tree a good bearer; not common.
61. *Mermaid*, fruit keeps well, and of good quality; not common.
62. *Bauldy Beard*, tree a good bearer; not common.
63. *Macbeth*, tree a good bearer; rare.
64. *Green Erin*, fruit keeps well, and of excellent quality.
65. *Carse Red Streak*, tree a moderate bearer; fruit very beautiful.
66. *Bonner*, tree an excellent bearer; a fine autumn apple.
67. *Monk*, tree a good bearer; rare.
68. *Bogmiln Beauty*.
69. *Seaside Leadington*.
70. *Stone Pippin*, tree an excellent bearer; fruit keeps well; beautiful small tree.
71. *Thicket*, an uncommonly great bearer; quality good.
72. *Tulip Wine*, inferior in quality to the *Green Wine*.
73. *Green Wine*, fruit of excellent quality; tree bears well, but sickly when old.
74. *Tower of Glamis*, tree a good bearer when in high culture; fruit of good quality, and excellently suited for baking; in Clydesdale called *the Gowrie*.
75. *Modified Tower of Glamis*.
76. *Modified Early Gowrie*.
77. *Gogar Pippin*, tree a good bearer; fruit of good quality, and keeps well; small upright tree.

Many other good late sorts exist in Gourdiehill Orchard. Of

these, some have not fruited this season, others are unnamed, or have not their names ascertained, or their qualities fully determined. There are also many varieties of earlier fruits, which of course are at present omitted.

PEARS.

1. *Seaside Bergamot*, small and close growing tree; fruit large, late, and of good quality.
2. *Grey Achan of Bogmiln*, one of the best winter pears in the Carse of Gowrie, as good as the Black Achan, and trebly more productive; know only one tree of good size in the Carse; fruit small.
3. *Paundie Bergamot*, tree good bearer; fruit large, handsome, and good.
4. *Pear Duncan*, tree one of the best bearers known; a few years ago existed only at Gourdiehill, but is now cultivated in different orchards; highly saccharine, but dry, and slightly styptic.
5. *Yellow Youte*, handsome, ordinary quality.

Additional Remarks by Mr Matthew.

Of the many varieties of apples I have cultivated, I consider the *Scarlet Golden Pippin* as perhaps the most valuable and the handsomest fruit. It ripens well on standards. As far as my experience reaches, the tree is healthy, gives fair and regular product, and comes soon to bearing. Probably it is a seedling from the Golden Pippin. We have only one old tree in this place.

I remember of mentioning to you a suspicion I had of modification, resulting from the admixture

of stock and graft in old trees, which is visible in the shoots sprung at, or near to, the point of junction, occasioned probably by the proper juice for the new deposit of wood in the stock being assimilated by the leaves of the graft, and thence partaking something of its peculiarities, or stamp of life. Those I have examined were sprung so immediately upon the point of junction, that I could not ascertain whether they belonged to graft or stock; if to the former, the thing is beyond dispute, but if, as I rather think, to the latter, we have only probabilities from similitude to deduce from, as there are no means of ascertaining what the original stocks were. Should the modification be of the latter, it is likely the change may extend to the furthest roots. I have some collateral proof which bears upon this; *e. g.* among trees grafted four or five years previous (rows of each kind) upon similar crab-stocks, the roots of one kind will have struck down very deep and strong, and another be more fibrous and superficially extended. The crabs on which the Eve or Irish Pitcher had been ingrafted uniformly struck the deepest roots.

I have also observed in young fruit trees, originally grafted a few inches above ground, and worked over again with another kind about six feet up, that the shoots which arose from the second working partook slightly of the habit and gait of the first.

I am aware, when the stock is at first diffe-

rent from the graft, in freeness of growth, thickness of bark, or in liability to be affected by cold or injuries, that these differences will be continued to old age, at least that they will not entirely disappear, but remain marked ; and that a thorny sprout will arise from the root of an old mild-growing grafted top. All this rather militates against the supposition that the stock is affected : but, from the cases which have come under my notice (five in number) all having the fruit bearing a marked similitude to those of the top of the tree, at same time evidently differing, and also the leaves bearing some resemblance, we are obliged to give it some portion of credence. If they be not affected as above supposed, it is certainly a curious coincidence. I have observed wartiness and canker, where the soil was not the disposing cause, sometimes transmitted to the graft from the stock. The several varieties of the same kind of apple, differing a little in taste, colour, figure, &c. most probably arise from something connected with this kind of modification.

There is a curious circumstance attending these new varieties, that most of them are destitute of seed. The same takes place (*viz.* a defect in forming seed) when the pear and apple have their juices slightly commixed by their stems being led up some distance in conjunction.—This fact, resulting from apple and pear juices commixing, is from an experiment by Mr Gorrie, Rait Garden.

LVI.

On the means of renovating Plantations of Asparagus, and on the utility of Top-Dressings.

In a Letter from Mr DANIEL ROBERTSON to the late Mr T. DICKSON, Secretary.

(Read 17th September 1816.)

SIR,

IN May 1813, I found the asparagus quarter here very much exhausted, by reason of the ground being too coarse and poor, and the shoots having been too severely cut in former years. Having a quantity of furnace-ashes, which had lain by for some years, I sifted these and mixed them up with a small portion of vegetable earth formed from tree-leaves. In August following I sifted both together, and laid the soil into a heap until the latter end of October, when about to dress in the asparagus quarter for winter. I then began at the one side of the quarters, and with a grape lifted the surface clean from off the crown of the plant; and from between the rows, (for my asparagus was planted in rows),

took away from six to nine inches of the old soil, or at least as much as I could conveniently manage without injuring the plants. The vacuities thus made, I filled up as I came along with the prepared compost of ashes and rotted leaves, and above the rows this compost stood about four inches thick when the operation was finished. On the approach of severe winter weather, I covered up the quarter with stable dung as I had formerly done; and over the covering I frequently, during winter, poured as much of the drainings of the dunghill as I could possibly collect. The following season the asparagus plants were not only much stronger, but produced a great many more shoots; and for these two last years, particularly the last, the shoots have been the best I ever beheld, both in size, quantity, and quality; in-somuch, that from four to five inches of a shoot were as tender and palatable as one inch of common asparagus.

I must here observe, that, in October 1815, when preparing to repeat to some extent the former application of ashes and tree-leaves, I found from the bottom of the compound to the very surface, one mass of fibres, the roots having spread in every direction, and even come upwards. I am convinced that top-dressing is as essential to asparagus as the preparation of the ground for its reception either at the time of sowing or planting.

I would farther observe, that, where the soil is poor and too light to be lifted in October, this may

be done in November, or early in December, or with equal propriety at the approach of slight frost, having the compound ready, and covering it over with litter at the same time that the quarter is covered.

The top-dressing compost might be thus composed: one-fourth sandy peat-moss, from the surface of a dry heath; one-fourth furnace ashes well sifted; and one-fourth vegetable mould formed from tree leaves; one-fourth well rotten stable dung, with a small portion of quicklime; all well mixed and prepared. I am, &c.

WALKENSHAW, }
August 1816. }

LVII.

Account of a collection of Gooseberry Bushes contained within an inclosure in the Nurseries at Perth.

In a Letter from ARCHIBALD TURNBULL, Esq.
to the Secretary.

(*Read 20th April 1826.*)

DEAR SIR,

YOU may make use of our list of gooseberries if you think proper to put it in your Society Memoirs. The inclosure where we have our gooseberries is nearly a quarter of an acre. I am so much hurried, that I have no time at present to give a general description.

RED.

Ackerman's Admiral Rodney.
Alexander.
Andrew's Esteem.
Aston's Red Globe.
Black Conqueror.

Black Eagle.
Mulatto.
Brandret's Don Quixotte.
Captain.
Cartwright's Conqueror.

- Cheshire Hero.
 Clark's Red Seedling.
 Cragg's Scarlet Drop.
 Dickenson's Soph.
 Duke of Cumberland.
 Fair Maid.
 Gill's Seedling.
 Great Lincoln Tap.
 Gregory's Perfection.
 Supreme.
 Conqueror.
 Captain.
 Colonel.
 Hamburgh.
 Hamson's Czar.
 High Sheriff of Lancashire.
 Halton's Red Date.
 Barley Sugar.
 Great Czar.
 Jackson's Slim.
 Royal Hero.
 Jarrott's Achilles.
 Ironmonger, Early.
 Late.
 Kenyon's Black Virgin.
 Large Murrey.
 Late Damson.
 Layforth's Seedling.
 Little John.
 Livesey's Duke William.
 Lamax's Victory.
 Maddock's Favourite.
 Master Tup.
 Mather's Early Red.
 Alexander the Great.
 Blackmoor Lady.
 Nero.
 Nonpareil.
 Nutmeg, Early.
 Pemberton's Earl of Derby.
 Pendleton's Great Mogul.
 Pendleton's Matchless.
 Raphael's Crispin.
 Beauty.
 Red Walnut.
 Champaigne.
 Rambullian.
 Red Robin.
 Richmond's Rasp.
 Rider's Old England.
 Royal George.
 Shepley's Black Prince.
 Shuffleton's Pumpkin.
 Stranger.
 Stumps.
 Thorp's Rumbo.
 Master Tup.
 Glory of England.
 Tillotson's Seedling.
 Tom of Lincoln.
 Tom of Lincoln's Son.
 Warrington Hedgehog.
 Red.
 Worthington's Conqueror.
 Hero.
 Nonsuch.
 Steel's Diana.
 Chadwick's Shepherd.
 Walker's Bank of England.
 Vailant's Fencible.
 Small's Rough Red.
 Sandyford's British Flag.
 Eckerley's Jolly Painter.
 Greenhalge's Jolly Minor.
 Brotherton's Overall.
 Collin's British Hero.
 Knight's Marquis of Stafford.
 Hermut's Fame.
 Hargrave's Glory.
 Leigh's Sir J. B. Warren.
 Wood's Glory.
 Brotherton's Pastime.

Derbyshire Prince of Wales.	Sander's Cheshire Lass.
Leigh's Rifleman.	Sledon's Lord Collingwood.
Chadwick's Sportsman.	Brundrett's Atlas.
Greave's Smolensko.	Yates' Earl of Moira.
Milln's Radcliff Ringer.	Rothwell's British Lion.
Fisher's Conqueror.	Allan's Battle of the Nile.
Horrock's Nonsuch.	Duke of Bedford.
Milin's Crown Bob.	Speachley's Yeaxley Hero.
Greave's Bloodhound.	Hartshorn's Lancashire Lad.
Pollit's Red Ocean.	Knight's Warrior.
Hopley's Jubilee.	Smolensko.

WHITE AND GREEN.

Anthony's Triumph.	Nickson's White Heart.
Banger.	Neill's White Rose.
Blackly's green Chesnut.	Platt's White.
Boardmen's green Oak.	Redford's White Lily.
Calderbank's White.	Rider's Triumphant.
Chrystal.	Sugar-loaf.
Coice's Diogenes.	Rawlinson's Royal George.
Crawfurd's Seedling.	Royal White.
Frontigniac.	Hero.
Green Chance.	Shaw's Hedge-Hog.
Walnut.	Shuffleton's Beauty.
Gascoigne.	Sweet Amber.
Fig.	Tailor's Rainbow.
Tiger.	Trial.
Globe.	White Belmount.
Gregory's Silver Drop.	Gascoigne.
Highland King.	Mogul.
Highland Queen.	Orleans.
Haslam's Greengage.	Rasp.
Hercules.	Royal.
Halam's Dumpling.	Walnut.
Hawley's Lord Wellington.	Worthington's Golden Fleece.
Jackson's Old Britain.	Royal George.
White Throat.	Worthington's White Chance.
Marlborough Green.	White Lily.
Mather's White Mogul.	Wriglie's Melon.
Miss Bold.	Collin's Favourite.
Monk's Green Joseph.	

Weedham's Delight.
 Moor's White Bear.
 Howard.
 Clough's Volunteer.
 Woodward's White Smith.
 Diggie's Green Corduroy.
 Mrs Clark.
 Edward's Jolly Tar.
 Broadman's Lively.
 Hopely's Shanon.
 Andrew's Dreadnought.
 Saunders's Cheshire Lass.
 Halton's Blunderbuss.
 Edward's Jolly Carpenter.
 Horsefield's Highlander.
 Smith's Mask.
 Haywood's Mount of Snow.
 Holt's Fair Play.
 Hill's Jupiter.
 Leigh's Defiance.
 Bradshaw's Cheshire Hero.
 Boardman's Jingling Johnny.
 Hall's Conqueror.

Wood's Duchess.
 Yates' Winter.
 Brundrit's White Rock.
 Broadman's Transparent.
 Allan's Glory of Radcliff.
 Jubilee.
 Forbes' Swallow.
 Crompton's Trial.
 Derbyshire Winter.
 Cheshire Lass.
 Greenwood.
 Waddington's Pendlehill.
 Brigg's Independent.
 Wellington's Glory.
 Wolstenholm's Leader.
 Green's Ocean.
 Spitsburgh's Lord Warden.
 Prince of Orange.
 Beaumont's Smiling Beauty.
 Cowsel's Great Britain.
 White Lion.
 Hamnet's Northern Hero.
 Sampson's Queen Anne.

YELLOW.

Andrew's Golden Griffen.
 Cheedle's Golden Lion.
 Globe Amber.
 Goliath.
 Goliath's Champion.
 Jackson's Goldfinch.
 Golden Orange.
 Jay Wing.
 Pendelton's Nonsuch.
 Robin Hood.
 Sampson.
 Speedwell.
 Stirrup's Golden Primrose.
 Thorp's Lamb.

Yeald's White Scarlet.
 Yellow Ball.
 Champagne.
 Rambullian.
 Vailant's Oldham.
 Taylor's Morning Star.
 Chadwick's Hero.
 Lord's Golden Dragon.
 Caldwell's Golden.
 Bell's Golden Farmer.
 Weedham's Good Intent.
 Forbes' Golden Cham.
 Nelson's Waves.
 Hopley's Cheshire Cheese.

Ville de Paris.

Aitkenson's Free Ranger.

Hill's Royal Sovereign.

Hall's Golden Gourd.

Braid's Glory.

Davenport's Jolly Hatter.

Bamford's Golden Purse.

Chadderton's Golden Shepherd.

Gorton's Viper.

Jackson's Golden Drop.

There is not a bad sort in the collection. We have many other new kinds, which we have not as yet been able to prove; and we are always adding to the number, as new approved kinds appear. I am, &c.

PERTH,
8th March 1826. }

LVIII.

Account of the mode of making various Liqueurs, &c.

In a Letter from Mr LEWIS PEDERANA to the Secretary.

(Read 6th December 1827.)

SIR,

I RECEIVED yours, requesting me to become author, by giving you a detail of my method of manufacturing liqueurs, which, I dare to say, you will find remarkable, if not original. These liqueurs, and the modes of making them, are, in a great measure, of my own invention; and, by many who have tasted the liqueurs, they have been pronounced excellent. If you think the receipts of the least advantage to the public, or worthy of a place in your Society's Memoirs, I will feel satisfied.

In the spiritous mixtures of my wines and liqueurs, I make use of a peculiar kind of home-distilled spirit, which I am pleased to term *Brandy*; an account of the manufacture of which I will give you in the first place.

Mode of making Home-Brandy.—Take twenty pints of fully ripe gooseberries, and twenty pints of white or red currants, bruise them, and mix with twenty pints of soft water, and two gallons of Port wine; and, if you choose to make the brandy of Scotch production, instead of Port wine make use of whisky; but the Port wine is preferable, as it gives the flavour of French brandy. Put these ingredients into any open vessel to ferment for a fortnight; then put the mixture through a press, or cloth of any kind, that will exclude the refuse; distil this liquid twice, and you will have the brandy colourless. From every twenty pints of the mixture you may draw ten pints of good brandy. I need scarcely add, that, to colour it, a little brown sugar burned may be made use of. This spirit, in the manufacture of liqueurs, I have found superior to mixing with other spirits*.

Mode of making Gooseberry Wine.—Take forty pints of fully ripe white or yellow gooseberries; bruise them well; add twenty pints of soft water, and 60 lb. of loaf sugar. Put them whole into any open vessel, say a cask without the end; stir them together, until the sugar be entirely dissolved. Let the whole ferment for a fortnight, and the refuse will

* A specimen of Mr PEDERANA'S Home-Brandy was sent to the Society in September 1828, and highly approved of.

separate: then make a perforation or hole within two inches of the bottom; draw off the liquid, which you will find as pure as water; put the liquid so drawn off into a cask large enough to admit of the spirits, and to every twenty pints of wine add three pints of the distilled spirit or brandy: let it stand in the cask for five or six months, then bottle it; and, in half a year, you will find it similar to Mossellas, and far preferable to many of the sweet-made wines.

Mode of making Creme de Rose.--Put four pounds moss-rose buds into ten pints of good whisky; let them stand for six weeks, shaking them twice every week; then squeeze the rose-leaves from the spirits: put the leaves thus squeezed into six pints of water; wash them well, and squeeze the liquid into the spirits: pass them through the still once, and, if it is not strong enough, put it through again: then take a preserving pan, put into it six pounds of bruised loaf sugar, two quarts of water, and the white of an egg, beat up to a froth; mix them thoroughly; put it over a stove fire, taking off the scum as it rises, until it become quite clear: then let it boil slowly, until reduced to a pretty thick shrub, taking care not to boil it so long as to colour the sugar; pass your shrub through a jelly-bag, and put it into any open earthen vessel to cool; then, to every quart of shrub thus prepared, put a quart of spirit of rose, mix them well together, and, if clear enough,

bottle it ; if not, pass it through the jelly-bag till it becomes so, and you will have *Creme de Rose*.

Mode of making Creme de Moka.—Take a pound of the best Mocha coffee, ground, put it into four pints of water, let it boil in a goblet or pan, over a slow fire, for ten minutes, to draw out the essence ; then pass it through a flannel bag. Then put it into a small still, with a pint of gooseberry brandy ; pass it until it becomes strong enough ; make a shrub for it as for *Creme de Rose*, and, when cold, mix in the same proportion, and you will have *Creme de Moka*.

Mode of making Kirschwasser.—Take any quantity of full ripe geans and cherries, and, in a mortar or wooden tub, bruise kernel and pulps. To every twenty pints of bruised fruit add five pints of water, and two pints of gooseberry brandy ; mix them, and let it ferment for a fortnight ; squeeze out the liquid, put the refuse under a press, to express the remainder, which is the best ; then put the whole into a still, pass it twice, and, if it is not strong enough, again, and you will have it as good as Swiss *Kirschwasser*.

Mode of making Cassi.—Take two pints of raspberries, two pints of black currants, two pints of red currants, two pints of water, and twenty pounds of brown sugar ; put them into a preserving pan, with-

out bruising ; let them boil for half an hour, taking off the scum as it rises ; then put it into any earthen vessel, until next day, or till cold ; then add four pints of gooseberry-brandy, and, after being mixed, put it into a cask or large jar, for six weeks : then pass it through your jelly-bag, when you will find it clear as claret ; bottle it, and in six months it will be perfect.

Mode of making Nonpareil.—Take a full ripe pine-apple, and pare off the outside skin ; bruise it in a mortar, add one and a half dozen of sharp ripe, white magnum-bonum plums, and one dozen of jargonelle pears, in the same state, quartered ; then to every four pounds of fruit add six pounds of loaf-sugar, and three English pints of water. Put the whole into a preserving pan, and boil them for three quarters of an hour, taking off the scum as it rises : then put it into a can or jar until cold, add three quarts of gooseberry-brandy, and let it stand for six weeks ; then pass it through your jelly-bag, and you will have the above fine liqueur.

Mode of making Admirable.—Take the outside skin from two dozen of full ripe peaches, quarter them, and take out the stones ; add to this the pulp of two dozen of ripe greengage plums, and one dozen of white magnum plums ; then to every four pounds of fruit add six pounds of sugar, and two quarts of water ; put the whole over a slow fire

for half an hour, taking off the scum ; cool it as formerly, and mix with spirits in the same proportion. The liqueur which results will be found to deserve the name of Admirable.

Mode of making Sublime de Variété.—Take equal quantities of Noyau, Creme de Rose, and Admirable ; mix them through a silk sieve, then bottle, and you will have an excellent variety.

HALYBURTON HOUSE, }
16th October 1827. }

The still which I have made use of in the manufacture of the before mentioned liqueurs, being of peculiar construction, I send a sketch.—*See next page.*

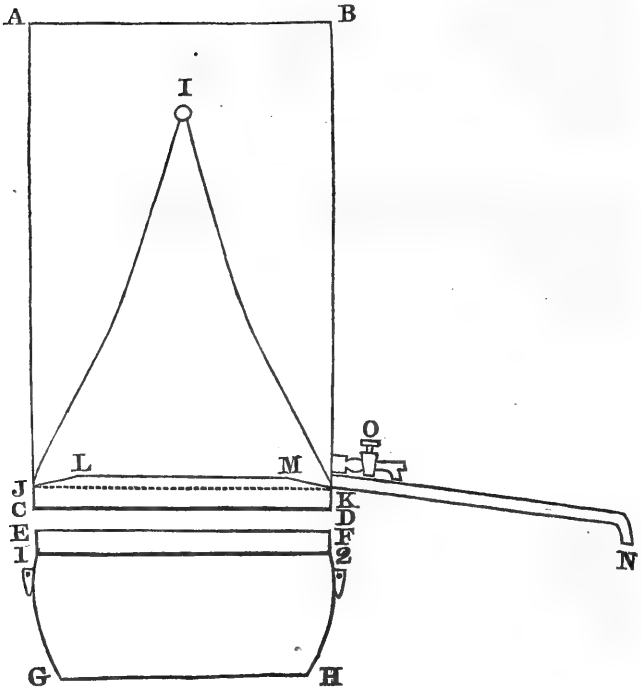

A, B, C, D, Tin iron-stand for the cold water, and fitting closely on
 E, F, G, H, the copper or boiling-pan,
 I, J, K, condenser,
 L, M, J, K, receiver of condensed spirits,
 K, N, rod for conducting off the spirits,
 O, cock for shifting water in the stand.

LIX.

Account of Fruit-Trees trained to a Wall inclined to the Horizon, at an angle of about 10°, in a Garden at Portobello.

In a Letter from WILLIAM CREELMAN, Esq. to the Secretary.

(Read 6th November 1828.)

SIR,

MY garden at Portobello being of an uneven surface, I was induced to take advantage of a rising piece of ground in it near the centre, and form two sloping or almost horizontal walls, of a circular shape. The whole will best be understood by the plan and section which you requested me to furnish you with. (See Plate X). Should you approve of this sketch, and consider it to be of the least use, you are welcome to present it to the Horticultural Society.

It will be observed that the circle is formed into two terraces, one above another, with a walk between, somewhat more than three feet broad. The soil under this walk, as well as under the lower walk, which is five feet broad, was prepared or enriched for the reception of the roots of the trees. The fruit-trees

are planted at proper distances, or about ten or twelve feet apart. They are of different kinds, apples, pears, and peaches. The walls (if they may be so called), are formed merely of bricks, laid flat on the surface of the ground, without any lime. The ground slopes at an angle of about 10° , and the wall is inclined to the surface, also at an angle of about 10° ; *i. e.* the bricks are raised some inches at the upper or back part. These almost flat walls are seven feet wide, the bricks are very hard burnt, having, indeed, been rejected at my brick-work on account of this quality. The trees are now four years old, and are singularly productive, especially the apple-trees. The apples are of uncommon size: this, I think, is owing to the sun's rays being earlier received, and retained to a later hour, than on perpendicular walls. The bricks lying on their bed get more heated than in upright walls, and by this means contribute more to the size and quality of the fruit. No vermin has yet appeared on these trees. It is evident that they must be much more sheltered from storms of wind than those trained to upright walls.

The appearance of these walls is rather ornamental than offensive to the eye. They are finished by a coping of a particular kind of composition-brick, made on purpose to suit the walls.

The apple-trees, especially the Ribston Pippin and Scarlet Nonsuch, bore uncommon crops this year. Two of these young trees, measuring toge-

ther in extension twenty-three feet in breadth, and five and a half feet wide, on the flat walls, produced together this season 230 large apples. This was much more than double the quantity found on any two trees of a similar size on the upright walls in the same garden. The fruit was likewise of a superior size and quality to those produced upon the upright walls; the apples measuring generally from ten inches to one foot in circumference. It has been mentioned that the trees are planted at about ten or twelve feet asunder: the present breadth of the walls is seven feet; but as the trees increase, the walls may be extended in breadth, particularly the inner circle, agreeably to the extent of the ground. I am, &c.

PORTOBELLO, }
1st Nov. 1828. }

DESCRIPTION OF PLATE X.

- a.* Central space covered with grass sward; 25 feet in diameter.
b b. Inner inclined wall, 110 feet in length, and having twelve trees trained to it.
c c. Outer inclined wall, 140 feet in length, and having fifteen trees trained to it.

The white spaces represent the walks, which are five feet wide, and laid with gravel.

The section was taken near the middle of the walls.



List of the Trees as marked on the Engraving.

- | | |
|-------------------------|-------------------------------|
| 1. Melville Pippin. | 15. German Nonsuch. |
| 2. Nonsuch do. | 16. Scarlet Nonsuch. |
| 3. Ribston Pippin. | 17. Ribston Pippin. |
| 4. Scarlet Nonsuch. | 18. Auchan Pear. |
| 5. Ribston Pippin. | 19. Crasanne Pear. |
| 6. Do. do. | 20. Mayduke Cherry. |
| 7. Jargonelle Pear. | 21. Black Heart Cherry. |
| 8. St Germain Pear. | 22. Wellington Apple. |
| 9. Do. do. | 23. Yorkshire Greening Apple. |
| 10. Do. do. | 24. Moorpark Apricot. |
| 11. Do. do. | 25. Magdalene Peach. |
| 12. Longueville Pear. | 26. Royal George Peach. |
| 13. Ribston Pippin. | 27. Hawthorndean Apple. |
| 14. White Hawthorndean. | |

Inclined Walls of M^r. CREELMAN'S Garden Portobello

Upper Garden

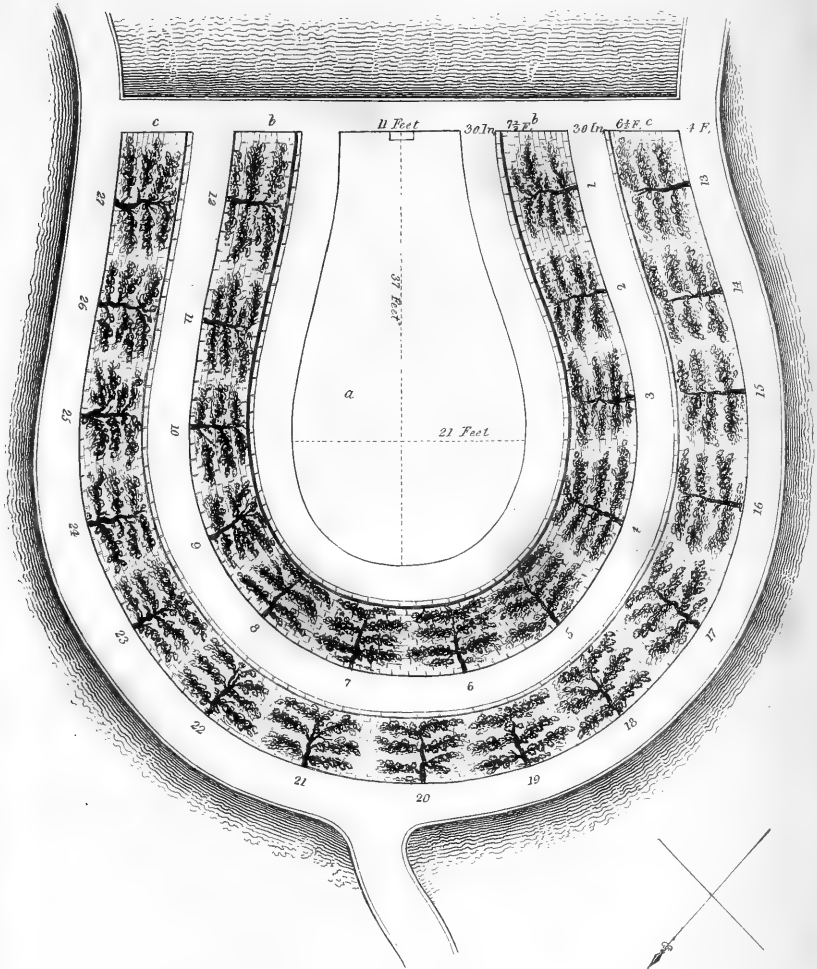

Lower Garden

Section





LX.

*Postscript to Dr WILLIAM HOWISON'S Paper on
the Culinary Vegetables of the Russian Em-
pire.*

Communicated by Dr HOWISON, and read 7th June 1827.

Russian Cucumber.—**T**HE following receipt for salting cucumbers I received from John Booker, Esq. British Vice-Consul at Cronstadt, and its accuracy may be depended on.

Wash the cucumbers clean, put them into a keg, pour a pickle of salt and water upon them, till the keg is full. The general quantity of salt is about four ounces and a half to each gallon of water.

The universal seasoning is dill-tops, before the seeds are ripe, with black currant and oak leaves. People of more refined taste add some garlic, horse-radish, and even sweet herbs; but the last very seldom.

The keg must be hermetically secured to exclude the air, and must not be too large, as the sooner used after being opened, the finer are the cucumbers.

Russian Method of preserving Culinary Vegetables through the Winter.

Cabbages are preserved in the gardens (set close together to save room), by building a roof over them of old boards, covering them with the old dung of the hot-beds, or the cleanings of the gardens, and then shovelling over all the earth from the adjacent beds. If the ground is dry, and it is possible to dig downwards, the house, if so I may call it, will be warmer; but the best situation is the brow of a hillock. Two tubes or chimneys are adapted to let out the confined air, when it thaws, or towards spring.

Leeks, celery, in short all similar vegetables, may be preserved in the same way.

The chimney must be stuffed up when it freezes.

An arrangement of this kind would do well in some of the northern parts of Scotland, where there is plenty of whin, broom, or heather, to make a covering, and where the frosts are never remarkably severe.

The following is the mode of preserving French beans, parsley, celery-leaves, and spinach, through the winter :

Gather the leaves or beans without washing them, put them into a barrel without a head, alternate layers of vegetables and salt. Then put a board upon

the vegetables, and a weight upon the board, which will now be covered with the juice of the vegetables. When wanted for use, take out the quantity required, and wash it carefully, retaining the board and weight. The best weight is a clean water-worn stone, tolerably heavy. The watery juice toward the board excludes the action of the air, and prevents putrefaction.

Parsley, celery, and spinage-leaves, carefully dried, and kept from moisture, are excellent for soups, &c.

9. NICOLSON SQUARE,
June 1827.

LXI.

On the kinds of Grape-vine best suited for Hot-walls in Scotland.

In a Letter from Mr GEORGE SHIELLS to the Secretary.

(Read 2d November 1827.)

SIR,

WITH reference to the Society's circular respecting the kinds of grapes best suited for hot-walls in Scotland, I beg to remark, that, after seven years' experience, I am of opinion that the White Muscadine and Black Hamburgh grapes are most deserving of a flued wall. Next to these, I would prefer the early July black cluster, and currant vines, being good bearers, and hardy trees; and the wood and fruit of these sorts ripening with less artificial assistance than any other I have yet tried.

Some young plants placed upon the apricot division of the flued wall, produced this season a few clusters of fruit which attained a tolerable degree of maturity, without any particular attention being paid to them, and without any assistance except

that arising from a little fire-heat, applied in the autumn, for the purpose of ripening the young wood of the apricot trees. From what I know of the Frankindale grape, I am persuaded it also would do well ; but I have not yet proved it.

I have this season altered my mode of treating the vines on the flued wall, by which I have been able to obtain a more abundant crop. Instead of applying fire to them in the spring, as formerly, I left them unnailed and projecting from the wall, until the month of May. At this time the clusters began to appear. I then had the vines nailed to the wall, and protected at night by a screen drawn over them. No fire-heat was applied until the beginning of July, when a little was given in the evening ; and in wet or cloudy weather, it was continued throughout the day, to protect the flowers, and promote the setting of the fruit. The screen was also continued during the night, until the latter end of the month of July. The fruit being then all fairly set, the screen was laid aside until October, when it was again put up at night to protect from frost. The fire was continued until the fruit and wood were ripened, on which depends much of the success of the following year.

I am partial to the black Hamburgh vine ; for, besides being an abundant bearer, and producing handsome clusters, it is hardier both in wood and fruit, than some others. The bunches hang longer, without the berries shrivelling ; and they are less

liable to be injured by the beating rain and wind in autumn than most other sorts.

The fruit now sent was produced under many disadvantages : in particular, it was shaded from the sun from the latter end of September, by a belt of tall forest trees in front ; and the space of wall allotted for one furnace, viz. 45 feet by 15, I consider too large for grapes. Add to this, that the present season has been an unfavourable one for ripening late fruits ; and their progress was still farther retarded by my having unfortunately left too heavy a crop on the vines. Notwithstanding all these disadvantages, however, some of our Muscadine grapes were ripe as early as the beginning of October.

I herewith send specimens of all the different kinds of grapes which I tried on a flued wall ; but the best and ripest were gathered occasionally as they were wanted.

A flued wall of the most approved construction has recently been put up in the new garden here, the vine division of which embraces all the above varieties of grapes. To these I intend to add the Sweet-water and Black Muscadine, these being planted in a well prepared border ; and, from the superior construction of the wall, which is well suited for equalizing the heat over the whole surface, and being in sheltered situations, with an open exposure, the vines have every chance to succeed, and, I expect, bear fruit superior to that produced in the old garden. With such a selection of the most approved kinds of grapes for the open air, upon rather

an extensive scale, and under such favourable circumstances, I hope I shall soon be able to give you a more accurate description of the comparative merit of the different kinds.

At a Meeting of Council and Committee, held on 2d November 1827, the Society's Silver Medal was awarded to Mr Shiells for this communication, accompanied with excellent specimens of the different kinds of grapes ripened against the flued wall at Erskine House Gardens. The black Hamburgh grapes were decidedly the best.

P. N. *Sec.*

ERSKINE GARDEN, }
October 31. 1827. }

LXII.

On the Use of Hop-Tops as a Culinary Vegetable; and an Account of different Modes of Dressing Gourds for the Table.

In a Letter to the Secretary from Mr LEWIS PEDERANA,
Halyburton House.

(*Read 18th September 1828.*)

SIR,

OBSERVING in your schedule a notice desiring an account of any new or improved vegetables, and particularly the modes of cooking and preparing the gourd, and its varieties, I now submit for your inspection, first, a few hints respecting an excellent, wholesome, and very valuable culinary vegetable, when rightly managed and prepared; and I shall, secondly, describe several modes of dressing gourds for the table.

The culinary vegetable alluded to, consists of the *tops* of that well-known plant the *Hop*. They form an excellent substitute for asparagus, when asparagus is out of season; and they may be had the whole

year round. Hop-tops also form an admirable ingredient for a variety of dishes, such as soups, omelets, &c. Long experience in the practice of cookery, both in this and in my native country, for upwards of forty years, makes me bold in recommending hop-tops. I was for some time in the kitchen of the King of Sardinia, where the art was practised in all its branches. I was afterwards thirty-four years with the Hon. D. F. Halyburton, as cook and house-steward. He being of delicate constitution, and eating no sort of animal food whatsoever, I was, on his account, obliged to study varieties of vegetable dishes. Hop-tops formed one on which I by chance stumbled, and of which he very highly approved, finding it agreeable and very wholesome.

I shall now give you a description of some of my modes of cooking and preparing gourds, which, if more fully known and understood, might add to the substantial enjoyment of a great number of persons who possess gardens, however small those gardens may be.

Of cooking Potiron Gourd, when fresh and full-swelled.

Cut the gourd into slices, and, after paring off the skin, put the slices into a panful of gravy, and, on the fire, boil them down to rag; then pass them through a hair-sieve, and season with white pepper and a little salt; put over the fire again, and boil slowly for half an hour. Then, in a tureen, put a handful

of grated Parmezan cheese, upon which pour the soup; mix them well together, then serve up. It will form an excellent dish, and give great satisfaction.

On Frying any kind of Gourd.

Slice them thinly half an inch broad, and eight inches long; put them, so sliced, into a sieve or calender; sprinkle a little salt over them, and let them drop for three or four hours to drain the juice; then put them on a cloth to dry; and, when a little dry, sprinkle some flour; and, a few minutes before dinner, fry them in hogs-lard, until they get brown and crisp; then serve them up. When scant of other vegetables, this will supply a good dish.

*To make a Soup of Gourds, similar to Soupe à
Lorraine.*

When the gourds are young and tender, slice them as above, for gravy soup; take two quarts of new milk; put the milk and gourd, so sliced, into a stew-pan; and, on the fire, boil them so as they will pass through a sieve; then, if too thick, add a little more milk; boil slowly over the fire for half an hour; then, just before using, take a mutchkin of fresh cream, and the yolks of six eggs; mix them all well for a few minutes over the fire; then season with nutmeg, and serve up.

To make Maigre Soup of Gourds.

Take a dozen of fish-heads, and, if you are boiling fish, keep the liquor ; put all the heads into it, with a small bunch of celery, parsley, and onions, with a carrot and turnip sliced ; let them boil down to rag ; then pass through a sieve ; add a small quantity of the gourd, sliced as before ; put them over the fire and boil, so as the soup may pass through the sieve again ; put it into your pan ; and, on the fire, season with it a little Cayenne and white pepper, and you will have a very fine soup, equal to gravy soup.

To make Soup of Gourd Tops.

Take a quantity of fresh tops of the shoots or stems ; cut them in short pieces ; parboil them, and drain ; then, half an hour before dinner, put them in a stew-pan full of gravy, over the fire, and boil them slowly for half an hour ; put in a few dice of toasted bread, and you will find this an excellent dish.

Another useful dish with Gourd Tops.

Collect enough to make your dish ; give them a half blanch, then put them in a sieve or drainer, with a sprinkling of salt ; after the first course goes up, lay them in a good batter, fry them in hogs-lard, and serve them up.

A good dish with newly set Gourds.

Gather a dozen of very young gourds when thoroughly set; take out the pulp from one end with the turnip-cutter; give them a parboil; fill the shells with good forced meat, such as you would put in patés; take 2 oz. of fresh butter, and a little flour; put the butter and flour in a stew-pan, and dissolve them on the fire; then add some gravy, and make pretty thick with the yolks of two eggs, and a little Harvey sauce. This will form as fine a corner dish as can be produced at table.

To preserve any kind of Gourd.

Cut off the top and bottom of the gourd; then cut it in rings, and pare off the skin, and, in thin slices, cut the rings longitudinally; dry them in the kitchen, on sticks, or on the screen; when dry they will keep for years; when you wish to use them, steep in milk-warm water for three or four hours; then dry them on a cloth; when dry put them in a sieve or drainer, and sprinkle some flour over them; sift out the flour; then fry them in hot hogs-lard. This makes an admirable second course dish.

Additional Communication from Mr LEWIS PEDERANA, dated Halyburton House, 9th October 1828.

To the SECRETARY.

SIR,

HAVING sent you, some time ago, some of my receipts for cooking gourds, I hope you will not think me troublesome if I send you two more.

1. Take young gourds, the size of cucumbers, cut them longitudinally in four; clear them of any pulp; if very tender, give only a parboil, and if hard, blanch them with a little salt; then take 2 ounces of fresh butter, and a table-spoonful of flour, which brown in a stew-pan, and pour on good gravy until pretty thick; put the gourds in this mixture; season them with white pepper and a little salt; and serve up. This makes an excellent centre or corner dish for the second course.

2. Take young gourds, as above, and likewise batter and flour as above; dissolve the batter in a stew-pan, but do not brown it; then take three yolks of eggs mixed well with half a mutchkin of cream, and half a mutchkin of sweet milk. Stir this before the fire until it becomes thick as custard; if not thick enough, add one or two yolks of eggs more; season it well with pepper and nutmeg; then put it neatly

on the dish, with all the sauce; strew over it a handful of grated Parmezan cheese; then put it in the oven to brown, or salamander it. This dish is one of the best of vegetable luxuries, and will defy the person who eats, to say of what it is made, unless he has previously known it. This is likewise a second course dish, and may be placed opposite the above.

LXIII.

On heating Hot-Houses by Steam.

In a Letter from the Reverend JAMES ARMITAGE RHODES,
to the Right Honourable Sir JOHN SINCLAIR, Bart.
dated Horsforth Hall, near Leeds, 22d September 1825.

(*Read 7th December 1826.*)

IN endeavouring to explain the mode of heating hot-houses by steam, I shall first state what were the difficulties which induced me to adopt that plan. The hot-houses here were formerly heated on the usual plan, by fires and flues. We have one pine-stove sixty feet long, one thirty, and one forty; all in the same line, and contiguous to one another. They have been built about twenty years; the flues had become shaken, and did not well retain the heated air and smoke. The consequence was, that the cavities between the flue and the front wall could not be used, and the air-vents were stopped up. By this means the front border got too much heated, and the roots of the vines were injured. The vines were made to push irregularly, and the

tender shoots were often spoiled by smoke and sulphureous vapour.

To remedy these evils I adopted this steam plan. I saw several hot-houses in London heated with metal pipes; iron or copper. But metal, I found, transmitted the heat too rapidly. I therefore have employed stone-flues, with only small subsidiary metal pipes. Lest the plan should fail, I left the flues and fire-places untouched, so that I could revert again to the old method without trouble or loss of time.

I provided as follows: I procured a boiler ten feet long, four feet wide, and five feet deep, with the usual appendages of safety-valve, supply-pipe, &c. This is heated by a furnace constructed upon the principles of Count Rumford. Underneath the walks in the houses there is a flue for the steam to pass along; this flue is formed by putting flags upon the former flags, with a line of bricks between, thus leaving a space equal to the thickness of a brick, or about three inches, for the steam to pass. The same is done under the pine pits; and, by this mean, the bark can be excited to new heat, and can be heated or cooled at pleasure, as there is a pipe expressly to heat each pit, with a cock to stop the steam, and an escape-pipe to let it off, if required.

The principal distinction is the employment of *stone-flues*, as the medium for conveying steam; but, as already noticed, under the stone we have small cast-iron pipes of different lengths, such as are

used by Oil Gas Companies, (with joints screwed together) to distribute the steam more rapidly and equally through the whole length of the steam-flue, as thus :

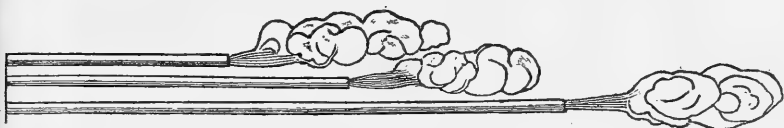

For our houses, in an average winter day, four bushels of coals will keep the heat requisite for pines for twenty-four hours. We have only one fire to attend to, and that will keep in, and not require any attention, from ten at night to seven in the morning, in the severest weather.

The advantages are uniformity and purity of heat, economy of fuel, of labour and expence ; security from smoke or noxious vapour ; and general cleanliness and salubrity of air in the houses. We have adopted the plan about three years, and, in the last season, have got at the meetings of the Yorkshire Horticultural Society many prizes for the fruit produced in these houses.

We have closed up our fire-flues, and we have no prospect of ever wanting them again. To evince the economy of labour and expence, I may repeat that we have one fire instead of seven or eight ; and we burn three bushels of coals only instead of fourteen or sixteen, in the course of the twenty-four hours of a winter's day and night.

If we had new houses to erect, I think the expence would not be greater than on the old plan ; as the cost of the boiler, about L. 80, would be saved in the difference between the expence of fire-flues and flues for steam. But even if this were not so, it would be well worth any increased expence, because hot-houses are places of luxury ; and the difference between the pleasure of being in a hot-house heated by steam in this method, and one heated by fire-flues, especially to those who have tender lungs, is very great indeed. The health of vegetation, in the steam houses, is proportionally improved.

Additional Particulars, communicated 23d November 1826, in answer to Queries by Mr NEILL, Secretary.

I WILL answer Mr Neill's inquiries most cheerfully. The steam is conveyed to each hot-house in one cast-iron pipe of three inches diameter *in the bore*. When it has got down to the front walk, the pipe has a flange, to which is screwed on a sort of trident, having three pipes and three holes : into these are screwed three pieces of pipe, such as are used for conveying gas in the streets, of cast-iron, of one and a-half inches diameter *in the bore*.

These pipes deliver the steam in three different

parts of the front walk ; the first at a yard or two off the end next the steam-pipe ; the second nearly in the middle ; and the third at three-fourths of the length. The whole length is sixty-five feet.

The object of this plan, is to diffuse the steam more equally and gently than it would be done, if it were suffered to escape *at once* at the large orifice of the main pipe. The same plan is adopted for heating the pine-pit. The steam-flue under the walk, however, has no connection with the pine-pit ; but is separated totally from it ; because that flue is used *daily*, whereas we have only recourse to the flue under the pine-pit, (or more properly the false floor), when the fermentation of the tan is languid.

The large pipe, therefore, is for conveyance ; the small ones are for diffusion.

The distribution of the steam is quite uniform throughout the flue, in consequence of the unequal length of the pipes. The quantity admitted can be regulated by a cock on the main pipe.

The pipes are all of iron. Lead is improper, as it curls, twists, and bursts.

The breadth of the flue is two feet and one and a half inches.

It is the full breadth of the walk, except the spaces occupied by the bricks, which support the stone cover on which we walk.

The pine-pit is constructed of thick and high flags sunk in the ground ; the bottom of the flue is flagged against these perpendicular stones. The

bricks are placed upon the bottom, and cemented, so that no connection for steam exists between the flue and the hollow floor of the pine-pit. The front flue is laid upon a very gentle descent, the end at which the steam enters being the highest. The condensed vapour runs to the lower end, where there is a pipe plunged in water in the drain. By this pipe it passes, causes the vessel to overflow; and escapes down the drain without any loss of steam. The flue passes all round the house; that is, all the walks are hollow, so that, if the front flue is full, the steam proceeds up the end, and along the back walk, which is two feet six inches wide. The back walk is seldom much affected by the steam, because a moderate quantity in the front is sufficient; but, as it is unconfined, in severe weather, when more steam is generated, we have the back walk warmed by the steam passing along it. We consider this immaterial, except as it tends to keep the tan warm all around, by which its heat is retained more regularly throughout the pit; for, as it is large, containing frequently from 400 to 500 pines, unless the bark be of equal age, it would not heat equally.

Attention is necessary to the *quality of stone*, as that which is of a porous or clayey nature becomes damp. A stone also composed of open layers, loosely connected, is objectionable, as it is apt to come off in large pieces, and to render the face unequal and irregular.

If any one object to the additional expence of three small pipes, I have no doubt one large one would answer equally well, if it had holes drilled into the side of it, at different intervals, through which part of the steam would escape on its progress towards the end.

The thing to be avoided, is the violent rush and heat which would take place if the steam came at once out of the large pipe.

I wish it to be understood, that I do not particularly recommend my plan of having the steam *below the walks* ; but, under my circumstances, that was the only plan I could adopt, as I had already houses constructed on the old plan, which construction I was desirous *not to alter*.

My fire-places, smoke-flues, &c. remain to this hour quite entire ; but they have not been used for six or seven years.

It is probable that if I were to build new houses, I might make walks without steam under them ; as they are hot to the feet of the gardener in the winter nights (not so hot as to be painful however), and are wet when he is steaming the houses, as water is poured upon the hot walk to generate steam for that purpose.

We *never* allow any escape of steam into the house from the pipe, as it would be too violent, too hot, and too *local*.

In the other mode, we can produce the finest, most gentle, and most perfect dew ; and can render

the houses so misty, that, no object can be seen at the distance of a few arms length.

The result of the whole is, that we have the finest pines and grapes.

But this, of course, depends upon the gardener also ; because no plan of heating, however complete, can dispense with the necessity of constant attention, vigilance and skill.

I will only add, that, by this means, the air of the hot-houses is perfectly pure and agreeable, as it is free from all vapour from coals or fire-flues. The furnace is fitted up on the plan of Count Rumford, with double doors and regulating air-slide, and the boiler is set with a wheel-flue capable of heating it with the smallest quantity of fuel.

This, as far as I know, is the best plan of economising coal, and producing the least possible quantity of smoke.

HORSEFORTH HALL, }
23d November 1826. }

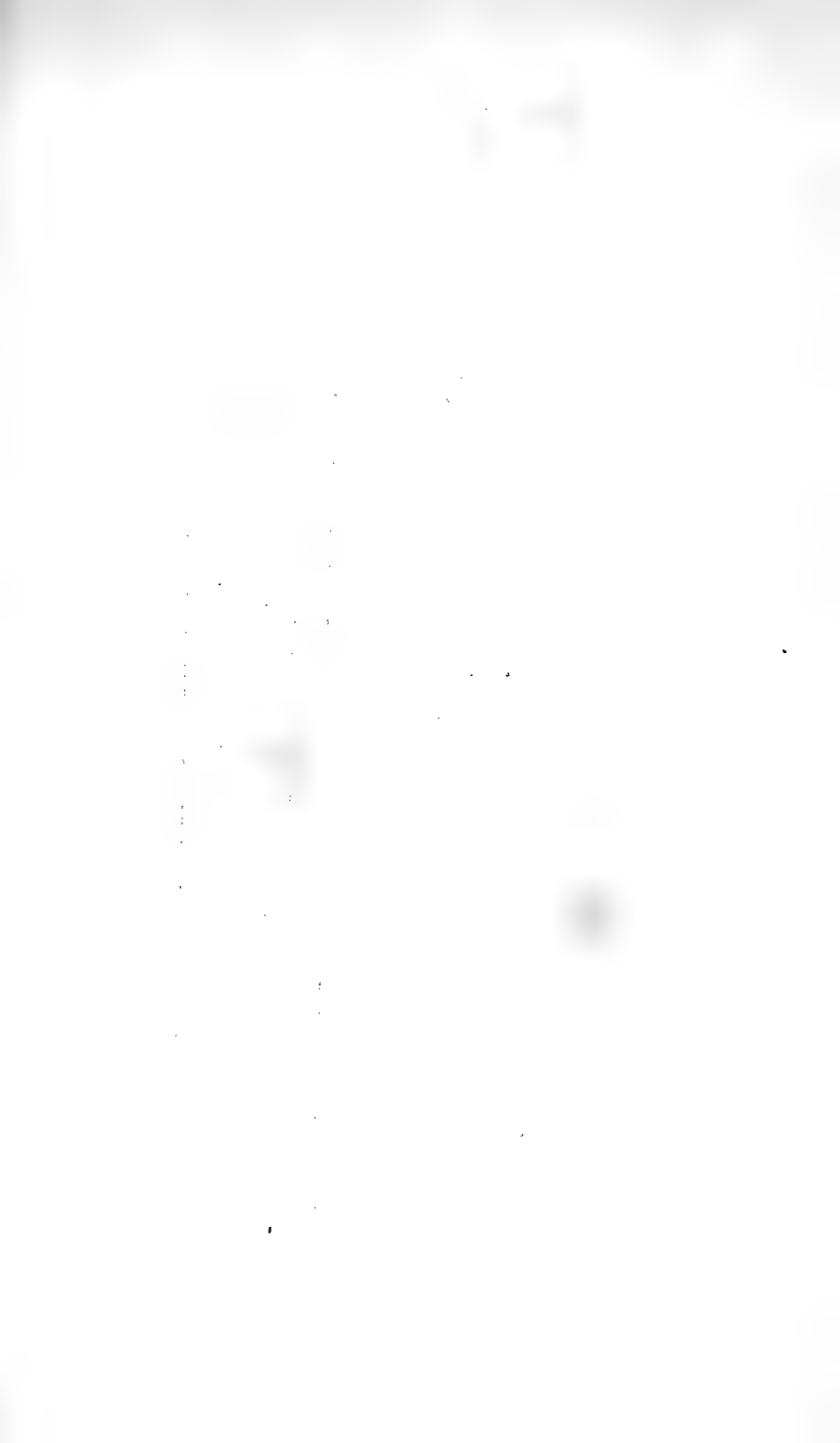

PINE PIT .

PLATE XI .

Fig 2. Cross Section

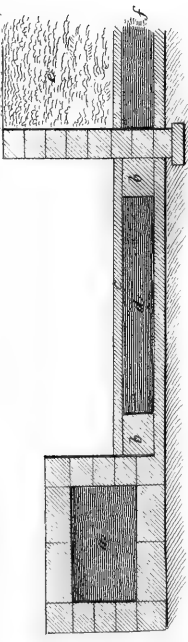
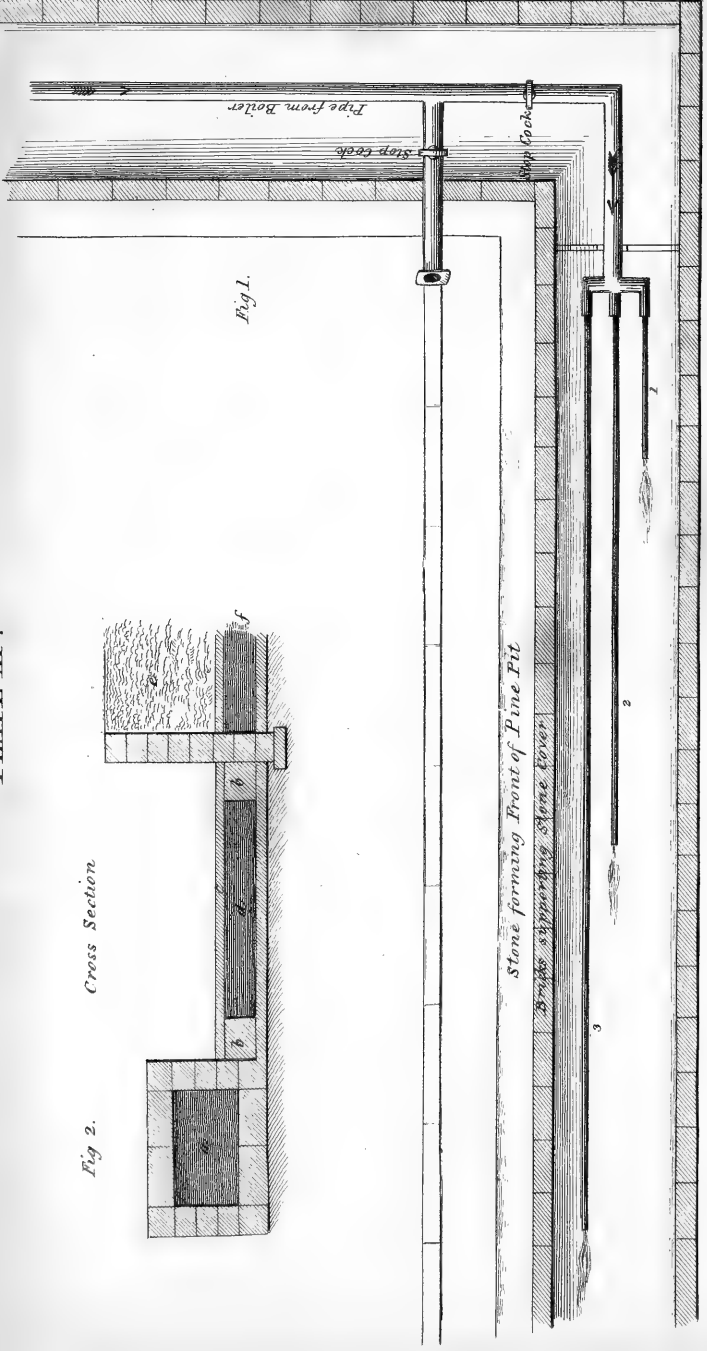

Fig 1.



EXPLANATION OF PLATE XI.

Fig. 1. PINE-PIT, having a hollow bottom, and pipes similar to those in the walk, but not represented, to avoid confusion.

A representation of the mode of diffusing steam equally through the front flue of a hot-house. The stone cover supposed to be taken off. The whole flue is 63 feet long.

Pipe 1. is 1 yard long.

2. is 9 yards long,

3. is 14 yards long.

The trident is 4 feet from the end of the flue.

The paper does not admit of the drawing being made by a scale, it is merely intended to shew how the pipes are attached to the main pipe.

Fig. 2. CROSS SECTION.

- a* Old fire-flue, left lest the steam should at any time fail.
- b b* Line of bricks, for supporting the flagstone *c*. Upright flags introduced between the line of bricks and the old flues, would prevent any shrinking in the brick-work.
- d* Space through which the steam and steam-pipes pass.
- e* Tan-bed in which the pine-apple pots are plunged.
- f* Hollow space below the tan-bed, which may be filled with steam when required.

LXIV.

Account of a mode of training Vines on the outside of the alternate sashes of a hot-house, by which means excellent Grapes were produced.

In a Letter from Mr JAMES MACDONALD, Dalkeith Park,
to the Secretary.

(Read 7th Dec. 1826, and 4th Jan. 1827.)

DEAR SIR,

I SEND you three bunches of Black Hamburgh Grapes from the open air, without the assistance of any artificial heat whatever, but trained over the sashes of a glazed house. Good as these are, they are nothing like some of the samples thus produced, either for size or quality. Fine specimens of the grapes have been taken to London, and different parts of England as well as of Scotland, as rarities produced in our northern climate. I may safely say, that not less than from 30 to 40 pounds weight have thus been sent away as samples, and yet I think I shall have a regular supply for the table till spring.

I would not have troubled the Caledonian Horticultural Society with them ; but perhaps nothing of the kind has been produced before, from the open air, at this time of the year. I am, &c.

DALKEITH PARK, }
Dec. 6. 1826. }

The bunches of Black Hamburgh grapes which accompanied this communication, were well swelled, and of the richest flavour, the summer and autumn of 1826 having been peculiarly favourable ; and the General Meeting, 7th December 1826, voted an extra medal to Mr Macdonald, and desired the Secretary to request for information regarding the practice. In answer to his inquiries, the following additional communication was received from Mr Macdonald.

Additional Information.

Letter from Mr MACDONALD to the Secretary, dated Dalkeith Park, 22d December 1826.

DEAR SIR,

I HAVE to acknowledge yours of the 12th instant, wishing to know the mode in which the grapes were grown in the open air at Dalkeith; and I shall be most happy to communicate the whole process practised here.

The vines have been planted about fifteen years, out-side of a small stove for the cultivation of tropical plants. The vines have generally been brought into the stove every spring, and trained up to the rafters, to produce their fruit; and in the autumn, when the fruit was mature and cut, the vines were turned out to the open air to winter.

But for these two or three years past, in the spring, when the vines were introduced into the house for a crop, I left some of the short wood on the vines outside in the open air; and I found that they matured their fruit every year, equal, both as to size and quality, to those within the house. This year (1826) all the rafters in the stove being covered with choice ornamental creepers, I was induced to make a trial of my whole vines in the open air

out-side. Accordingly, in the spring, when the buds began to swell, I laid the whole vines down on the ground ; and to preserve them from the spring frosts, I covered them over with mats and spruce-fir boughs, till the end of May. I then trained all the shortest vines on the front ashlar-wall, which is about two and one-half feet high, filling in as many as it could contain.

I then took the longer shoots, and trained them up the front upright rafters, keeping the upright front glass clear. I next procured some very thin laths, and tacked them on each alternate fixed light on the sloping roof, so as not to prevent the running lights from giving the usual air for the house and plants. We tied the vines to the laths as we went along. They remained in this state till the end of August ; when I found that those vines on the sloping glass were not making such progress as those on the front ashlar building, or on the front upright rafters, the fruit not swelling equally well. With a view to remedy this, I, and one of my young men, got a few blocks of wood, five inches high, and one and one-half inch in width, and nailed them upright on the centre of the long rafter, two feet three inches apart, on each alternate light ; we got long laths, and stretched them along these blocks, in the direction and according to the slope of the sashes, nailing the laths to the blocks. Then we began at the bottom of the light, and got some small laths to reach across the light. We nailed on stretchers on the top of the laths, and then lifted up the vines and

grapes, on the top cross stretchers, tying and regulating them as we proceeded. The cross laths are placed about eighteen inches asunder ; thus placing them about seven inches above the rafter, and about ten inches above the glass. This finished the operation.

In a short time, the progress made by the grapes in swelling was quite visible; and, at the same distance from the glass, they remained till ripened in October and November.

The kind of grapes are Black Hamburgh, Black Burgundy, Green Chasselas, White Constantia, White Muscat of Alexandria, and Black Gibraltar. The three last mentioned, being the most tender, were unfortunately placed on the north end of the stove, where they had nothing but the afternoon sun : nevertheless, several gentlemen who tasted them, declared them excellent, both for size and flavour. I have no need to mention any thing with regard to the general quality of the grapes, or the prolific state of the vines as to bunches ; both have been witnessed by hundreds, and by many good judges.

A serious difficulty was to secure the fruit from wasps and birds, both of which are very abundant and destructive at Dalkeith. I got some catgut at $3\frac{1}{2}$ d. per yard, and taking $2\frac{1}{2}$ breadths, had them sewed together : this breadth covered the width of one light ; we then tacked the catgut close on each side of the lights, so as to prevent even wasps from getting under it. This proved quite effectual ; and



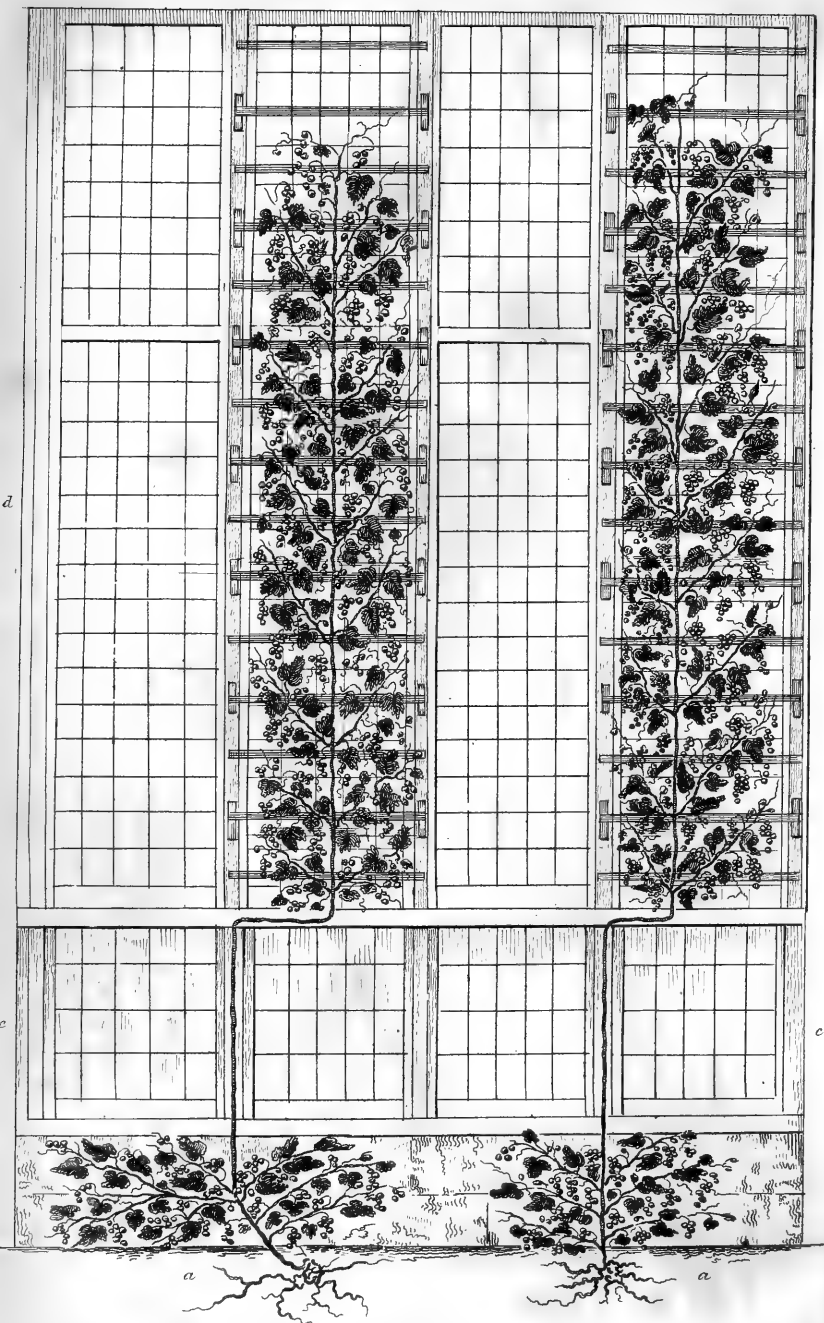

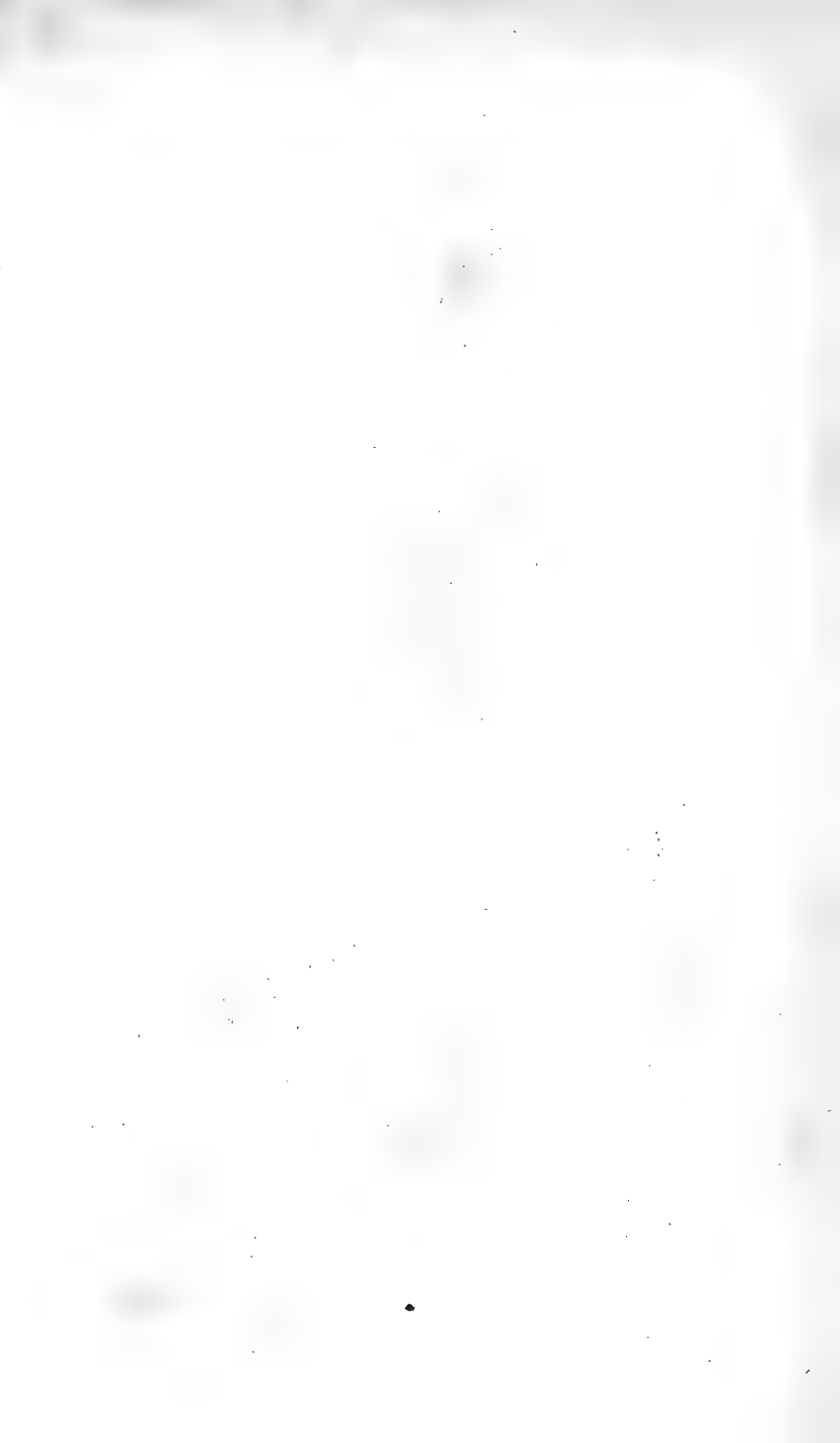

Fig. 1

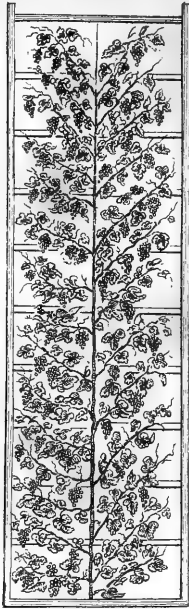

Fig. 2

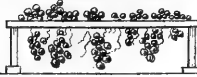
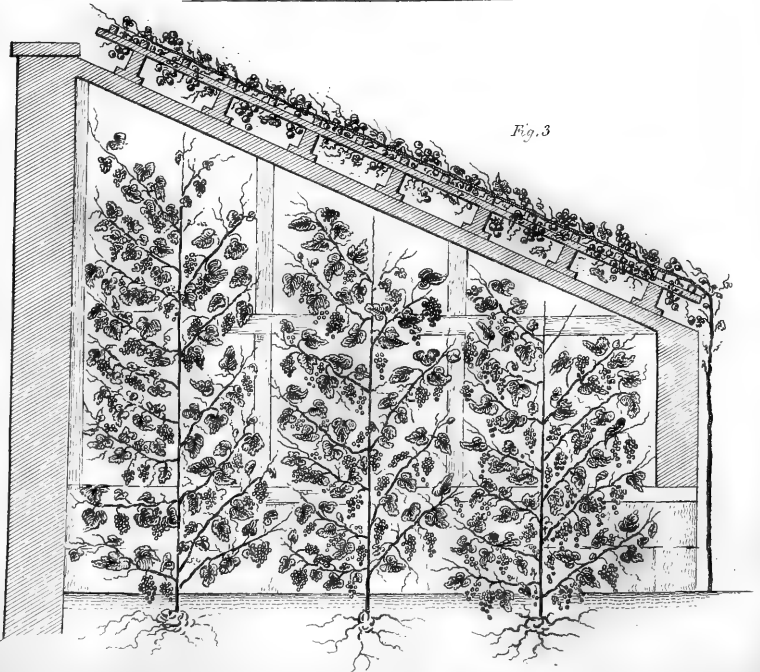

Fig. 3



the *catgut cover* as well as the laths, &c., will answer the same purpose for years to come, if required.

The accompanying sketches (Plates XII. and XIII.), are but roughly executed; but they may perhaps tend to make the description better understood; so that, upon the whole, a pretty accurate idea of the practice may be formed. I am, &c.

EXPLANATION OF PLATE XII.

- a a* Shew the vines trained on the alternate lights, and also on the ashlar.
- b b* Blocks. On the tops of the blocks are long laths, stretching from the top to the bottom of the sloping sashes; and on these, again, are cross laths.
- c c* Upright front lights.
- d d* sloping lights.

PLATE XIII.

- Fig. 1. Vine as trained on sloping sash.
- 2. Section of the same.
- 3. End view of the hot-house.

LXV.

Another Hit at the Caterpillars.

In a Letter from Mr MACHRAY, at Annat, to the
Secretary.

(*Read 5th June 1828.*)

SIR,

NOTWITHSTANDING the many receipts which have been given, holding forth immediate destruction to the whole caterpillar tribes, they, in many instances, still maintain their ground, and continue their voracious depredations. Having formerly voted the gooseberry caterpillars to perdition, with the application of soap-suds and tobacco, (Caledonian Horticultural Society's Memoirs, vol. i. page 272.), I now endeavour to seal the destruction of such as infest and destroy the foliage of apple-trees. Considering that prevention is better than cure, I have, by the following means, prevented them from reaching that foliage, which the parent, by natural instinct, had intended should supply her larvæ, when they emerged from the chrysalis state, at the root of the apple-tree. Where the tree was covered with

mossy, scabrous bark, judging it might be possible some of the eggs had been lodged in the crannies, I rubbed off the moss and scabrous part of the bark, and in place of rinzing with tar, as had been recommended by some old horticulturists, I thought of insulating the trees with water. For this purpose, I got strong clay in January, and beat it up with one-fourth of its bulk of horse-droppings in the same manner as grafting clay, a process familiar to every gardener ; after it is properly beat up, it is laid in a heap in a back shade, and covered up from frost and drought, where it acquires additional toughness. In the beginning of March, when it is time to apply it, I removed a little earth from around the stem of the tree, sufficient to admit clay to form a cup four inches wide, by three inches deep, as represented by the following section.

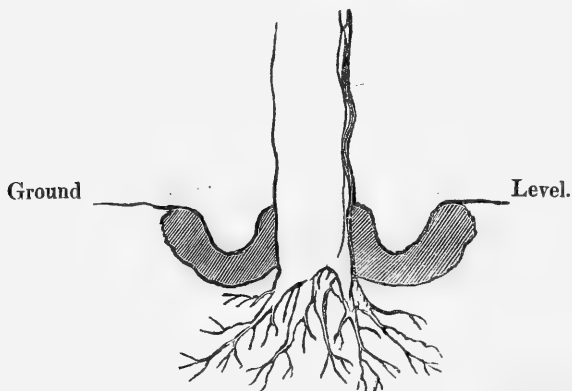

The circular canal thus formed is to be filled with water.

The clay should be at least three inches thick, to prevent the water from escaping. The water should be renewed in the evening, as often as it is nearly evaporated, and the person supplying it should observe if there are any cracks in the clay, which he can easily fill up or mend.

The clay basin should be kept full of water from the beginning of March till the end of June, during which time, numbers of the young caterpillars will be observed attempting to cross, and many will be found drowned. When they are very numerous, they may be occasionally swept off the clay and destroyed.

I communicated this method to P. Mathew, Esq. of Gourdiehill, a most zealous orchardist, that he might give the experiment a fair trial, upon a scale as large as I proposed doing the present season, as circumstances (which it is unnecessary here to mention) prevented the execution of that experiment by myself. I shall only add, that those who will give this scheme a fair trial, will find it less troublesome than they may at first sight suppose. The expence is only in the labour, and though regular and careful attention is absolutely requisite, to prevent the marauders ascending, the labour and care are amply repaid by the absence of such destructive vermin. I am, &c.

ANNAT, }
24th March 1828. }

LXVI.

*Of the Disease in Turnips called Anbury, or
Fingers and Toes.*

AT the General Meeting of the Caledonian Horticultural Society, held on the 2d September 1819, it was mentioned by George Bell, Esq. that the disease in Turnips called in this country *Fingers and Toes*, and in some parts of England *Anbury*, had this year prevailed very generally in several of the principal agricultural counties; and it was proposed that the Society should endeavour to procure correct information regarding that disease, and, if possible, the means of obviating its progress. The Secretary, therefore, prepared the following Queries, and addressed them to various gentlemen, who were understood to take a particular interest in rural affairs.

For how many years has the disease in turnips called *Fingers and Toes* been known in your district?

Have you any reason to think that it made its appearance first from the south; or from that district near Hull called *Holderness*?

Has it greatly affected the turnip crop in your neighbourhood this season (1819)?

When the disease has appeared in a field, have you observed whether it spreads over the whole, or in patches, or in the course of entire drills, or whether it be interrupted?

At what point of the growth of the turnip does the disease first appear; and by what symptoms on the foliage, or otherwise, is the ex-

istence of disease in the bulb indicated? How does it generally terminate?

What is your opinion as to the cause of the disease? Does it appear to have resulted from the nature of the season or climate; or has it any connection with the quality of the soil, as to newness, or manuring? Is it immediately caused by an insect depositing its egg, and a grub or caterpillar forming its nidus, in the bulb; has the progress of the larva been traced, so as to ascertain the species of insect; or does it result merely from a puncture made by some insect, without eggs being deposited?

Has any remedy been proposed or tried for this disease, and with what success?

Has the disease appeared in turnips raised on land newly limed? Has it occurred in crops raised on land recently broken up from pasture, or in land which has not before been cropped with turnips? Or does it occur most frequently in fields which have repeatedly been under turnip crop?

Does the disease equally affect all the kinds or varieties of turnip usually cultivated, or what particular varieties are more subject to it than others?

How does it affect the turnip as an article of food for cattle?

In cases where the disease has appeared, has the history of the seed employed been accurately examined; for instance, whether it has been raised in a garden in the immediate neighbourhood of other plants of the Brassica or Cabbage genus, or in fields near which the wild mustard and wild radish abound?

Has it been ascertained, whether the seed yielded by a plant affected with the Anbury, affords turnips of regular shape, or with misshapen and diseased bulbs.

A description of any remarkable example of the disease that may fall under notice, with some account of the progressive formation of the excrescence, its duration; its texture, its tendency to putrescence, its smell, and other characters, will be desirable.

Several communications were received in answer to the queries so circulated. The most important and satisfactory were those which follow.

1. *Letter from Mr GEORGE SINCLAIR, F. L. S., Woburn Abbey, Bedfordshire**, to Mr NEILL, Secretary.

SIR,

I NOW send the details of the observations and facts which have come under my notice, respecting the inquiries contained in your circular of the 20th of September last, regarding the disease of Turnips called Anbury, or Fingers and Toes. If they should be considered of any utility by the Society, in this important investigation, it will afford me much pleasure.

This disease, which is common to the different species and varieties of *Brassica Rapa*, *B. oleracea*, and to the *B. Napus*, has been observed in the field-crops of turnips, cultivated in this district for several years. It is a general opinion that it has been more prevalent and injurious to the field-crops of turnips this season, than in any preceding year. Should it increase much beyond its present extent, as an enemy to the turnip crop, it is feared it will be found more fatal than the effects of the *Beetle* (*Chrysomela saltatoria*), the *Fly* (*Aphides*), or the *Black Canker* (*Tenthredo Scrophulariæ*).

No reasons have offered themselves here to render it probable that the disease originated in any

* Now of New Cross, Surrey.

particular district. I have observed the galls or tubercles on turnips, ever since I had any knowledge of the culture of the plant, and these excrescences will be found to be the disease in its mildest state : therefore, until proofs are obtained, that the insect, which is the immediate cause of these excrescences, feeds and propagates on other species of plants, it may be considered as highly probable that this disease is as old as the turnip plant, and with it had its origin. Exciting causes, such as unfavourable seasons, soils, manures, culture, and to which may be added a less extended cultivation and interest in its success, seem only to have been wanting to render the effects of this disease equally striking formerly, as it is at the present day.

The effects of the disease are visible on plants about seven weeks old, but this is the earliest period of its progress observed by me.

The malady is first indicated by a want of natural vigour in the leaves ; for, although the leaves of a diseased root happen to be larger in all respects than those of a sound plant, yet, whenever the rays of a mid-day sun fall upon them, they flag or decline from their natural posture in a flaccid state. The extent and direction of the disease in a field can by this symptom be traced with ease and certainty. When the leaves are thus enfeebled, they are generally attacked by a minute species of *Acarus*, whose delicate web tinctures the leaf with a bluish-white appearance.

Whether the crops were cultivated in ridges, in rows, or sown broadcast, I have invariably observed the disease to spread in patches in an irregular manner over the field, proceeding, however, from the low lying points ; or, when the land was a general level, the disease appeared to begin, or at least raged with most violence at the most sheltered parts, or those contiguous to covers or plantations. Local hollows, even at the summit of rising grounds, I have observed affected, when the surrounding plants were sound. When a plant, which exhibits the above symptoms, is taken out of the ground, one or more galls are perceptible : these in time become large excrescences, which, when opened, shew a small grub or larva of an insect, which is furnished with two eyes, mandibles, and jaws. This larva, in very young plants, has the appearance of a minute globule of water, and is not to be distinguished by the naked eye. As soon as the insect is prepared to leave its nidus, the root, or that portion of it formed into galls, begins to putrify. The excrescence becomes soft and spongy, the rind bursts, and a fetid smell, peculiar to decomposing vegetable matter, exhales from it. Partridges appear to be very fond of the larva. Whenever they are seen to congregate among affected turnips, the galls are found perforated, and the insect taken out. Several insects are now attracted to the putrifying mass. A species of musca deposits its eggs on the surface. The larvæ burrow in the mass ; these are followed by different

species of *Staphylinus*, *Pæderus*, &c. The former of these seem to live on the larvæ of the musca, for two of these lived three months, while supplied with these larvæ, but died soon after the supply was discontinued. They did not appear to touch the matter of the turnip, on which the larva of the fly lived. Under these circumstances, when moist weather occurs, the mass affected soon wastes away, and frequently a large root is found a mere shell. The larvæ are found solitary: how great a number soever inhabits a root, every individual occupies a distinct cell. It appears to be a species of the *Cynips* of Linnæus, and the *Diplolepariæ* of Leach, Geoffroy, &c. * In the head, mandibles, jaws, &c. it is similar to the larvæ which live on the root of the cauliflower, broccoli, and other varieties of *Brassica Napus* and *oleracea*. The colour of the larva varies according to the colour of the root. It is white in the common field globe-turnip, and in cauliflower; yellow in the root of rape, and Swedish turnip, Scotch yellow, &c. The latter appear to be less

* Roots affected with the disease were planted in a soil prepared by boiling in water, so as to destroy every species of insect and eggs of insects. Planted in a pot, and protected by gauze to prevent the escape of the insects, the roots continued until April, when two perfect insects were found to have *eaten* their way out of two of the larger Anburies. They were dead when found. The characters appeared to agree with those of the above; and the colour was nearly a perfect black. This insect I had never seen before.

subject to the disease than the white globe and tandard varieties. In two instances where I collected specimens of severely affected roots, and also of the soil, for chemical examination, I found the roots had been in contact with a portion of tree leaves, which probably had come with the manure; but, in other instances, I found roots equally diseased, to which no manure had been applied. In some experiments instituted by his Grace the Duke of Bedford, which I have had the honour to conduct, on the nature of salt as a manure, simple, and combined with other substances, as stable-dung in different states, lime, soot, oil-cake, &c. applied in different modes, and in various proportions, to soils differing essentially from each other in their natural properties, as loams, siliceous sandy soils, clayey soils, peats and heath or moor soils, for the growth of the different useful species of agricultural plants; the results, as immediately regards this particular affection of turnips, have not been so decisive in favour of salt or lime as I had anticipated; for the disease appeared in every case, though in different degrees. Combinations of salt and lime were evidently the most effectual, as no instance occurred of the bulb being affected below the surface of the soil. That portion of it, however, which was above the surface, was affected with galls, the same as in the bulbs grown on soils of the same nature, to which no application of manure had been applied. On a space of the same soil, to which salt simply had

been applied the preceding spring, and from which time the soil remained fallow, the crop was good. One plant in ten, however, was affected with the disease below the surface, as well as above it. The salt, in this instance, had been applied at the rate of 86 bushels per acre, and mixed with the surface four inches deep. It was applied in the first week of May 1818. On one portion of it barley and turnips were sown, but they did not vegetate, the dose being too great. The season following, however, the crops were good. On the same soil lime was applied at the rate of 120 bushels per acre, and the disease was not less general than in the former case. Lime was applied to a clayey loam, and to siliceous sandy soils, at the rate of 120 bushels per acre to 25, and salt from 86 bushels to 5 per acre, but without any decisive effects in the prevention of this disease of turnips. The maximum and minimum of salt was here nearly ascertained. In every distinct soil the quantities applied were the same, and the trials made under the same circumstances. With regard to the mode of applying salt and lime for turnips, that of mixing it with the soil, previous to sowing the seed, or applying it to the surface after sowing, proved best; for, when salt or lime are mixed and deposited with the seed, vegetation is retarded from two to twelve days, and more, beyond the natural period. This fact was proved on the seed of eight different species of plants, sown on four different kinds of soil. How-

ever beneficial, therefore, salt or lime, in other respects, are to the soil (a subject not within the present inquiry), and, though they seem, when combined, to modify this disease, yet it appears they are not, either in a simple or combined state, a specific remedy for this disease in turnips.

Inert or barren peat-moss was submitted to experiment. 400 grains of this soil consisted of,

Fine pure siliceous sand,	-	-	-	29
Inert vegetable matter, destructible by fire,	-	-	-	289
Soluble vegetable matter, with sulphate of potash,	-	-	-	11
Alumina, or pure matter of clay,	-	-	-	14
Oxide of iron,	-	-	-	30
Gypsum,	-	-	-	12
Sulphate of iron, or green vitriol,	-	-	-	10
Loss,	-	-	-	5
				400

This soil, in its natural state, is absolutely barren. Slugs and worms die, when placed in the water that passes through it. In one instance, salt simply was applied, at the rate of 171 bushels per acre; another portion was manured with lime, at the rate of 1220 bushels per acre; to another space a mixture of these substances was applied, in the proportion of salt 171, and lime 1220. In the first of these, vegetation did not take place. In the second, a sufficiency of plants were produced, but the bulbs were small, and not well formed. The mixture of salt and lime was the most effectual applica-

tion. Every seed appeared to have vegetated, and grew well, till a course of dry weather checked their growth: afterwards, when much wet weather succeeded, the principal part of the bulbs decayed, the tap root becoming affected first. In the crop of the limed space, one plant in ten was affected with the Anbury disease; in that which received the mixture of salt and lime one plant in twelve was affected. In examining the soil taken from the spots of a field where the roots were severely diseased, I could not find any difference in the number or proportions of the constituent parts, from those of the soil where the plants were sound and healthy, only that the former contained more moisture, the water of absorption in the latter being to that of the former as eight to ten nearly. Mr Overman of Maulden, a most intelligent and extensive grower of turnips, pointed out to me a portion of one of his fields of turnips, where a road had formerly been. The disease was here general, and the whole line and space formerly occupied by the road could be clearly distinguished from the rest of the field, where the disease was only found in distant patches. A portion of the land which immediately adjoined to the site of the old road on one side, had been under tillage for a long series of years. On this space, consisting of several acres, an instance of the disease was scarcely to be found. In other cases I have witnessed the reverse of this, where the lands which had been the longest term of years un-

der the alternate course of husbandry, were the most affected with this malady, and the crops of turnips on lands recently broke up from permanent pasture scarcely affected by it, the soils, mode of culture, &c. being alike. The half of a large field in this gentleman's farm had a strong dressing of clay; the soil was a light siliceous sand, containing a notable portion of oxide of iron. The clay approached to the nature of marl, in regard to the quantity of carbonate of lime which entered into its composition. The number of bulbs affected with galls on the *clayed* land was greatly inferior to the number affected on the portion where no clay had been applied. These facts, joined to observations unnecessary to bring forward here, render it extremely probable that the *cause* of the disease cannot be traced to the nature of the soil, manure, or mode of culture, although it may be encouraged and fostered by them from circumstances connected with unfavourable weather and unskilful management.

I have procured seed from roots perfectly free from this disease, sowed in a situation excluded from the neighbourhood of any other species or variety of brassica, which, when sown on land that, to my knowledge, never was sown with turnip-seed before, and on old garden land, in both cases produced bulbs more or less affected by this disease. Whether the reverse of this takes place, I have not had an opportunity to obtain satisfactory proofs; and, until the minute particulars of the economy or na-

tural habits of the insect, which is doubtless the immediate cause of the disease, is intimately known, it will be difficult to proceed in devising any plan of prevention with a hope of certainty of success. One point is clear and evident, that, whatever increases the vigour and rapid growth of the turnip plant in its early stages of growth, checks with considerable force the progress and bad effects of this formidable disease. I divided a perfect and fine grown turnip, in order to obtain some information of the form and disposition of the cellular texture, and the compressed air-vessels, as they appear in a healthy state, opposed to that severely affected with the *Anbury*. On passing a glass over the inner surface of this healthy root, I found one of the larvæ situated in the second circle of air-vessels next to the centre of the bulb, without the smallest indication of any passage to the outer surface. The insect was too small to be seen with the naked eye. It had been deposited there in the egg state at a very early stage of the growth of the plant. The vigour and rapid growth of the bulb had been probably, in this instance, superior to the poisonous nature of the grub; for it is difficult to conceive, without some such power or agency, so soft and slender a body as the insect actually appears to be, while in infancy, should be able to resist the powerful pressure caused by the growth of the plant, which is, in that part immediately surrounding the worm, increased much beyond its na-

tural state, from the irritation of the wounded air-vessels causing a preternatural flow of the sap to that point. It is worthy of remark, that no trace of excrement is apparent in the cells even of grubs which have nearly attained to their full size, though a considerable vacuity surrounds them. A bulb, which had one of the galls cut away, was placed in a warm, moist situation, out of the soil, and, in the space of three weeks, fresh substance of the root was formed from the upper lip of the wound, of the thickness of one-fifth of an inch, so powerful was the effort of nature to replace the part after the poisonous matter was removed.

This disease appears to lessen the nutritive powers of the turnip, in various degrees, according to its violence.

875 grains of a perfectly sound root of the white globe turnip afforded of nutritive matter,	-	46 grains
875 of a root slightly affected,	-	40
875 of a root wholly diseased afforded only,	-	18
		—

The nutritive matter of the healthy root consisted,		
of mucilage,	-	8.
Saccharine matter,	-	35
Gluten, or matter coagulated by heat below 130°,	-	3
		— 46

The nutritive matter of the slightly diseased root		
gave mucilage,	-	9
Saccharine matter,	-	30
Gluten, or albumen,	-	1
		— 40

The nutritive matter from the severely affected root appeared to consist of mucilage,	10
Matter analogous to gluten or albumen,	8 *

The insoluble portion of the healthy root consisted of vegetable fibre; that of the severely affected root consisted of vegetable fibre, in an indurated granular state, containing matter nearly soluble in a large quantity of boiling-water, and separated from the fibre by pouring it off while in a state of suspension. This substance possessed a disagreeable smell, similar to that of putrifying vegetable matter. It seems highly probable, therefore, that the nutritive qualities of the turnip are greatly lessened by this disease; and that it must be hurtful to the health of sheep and cattle which feed on the roots affected by it.

WOBURN ABBEY, }
Dec. 1. 1819. }

2. *From the late ARTHUR YOUNG, Esq. dated Bradfield Hall, Bury St Edmund's, 7th October 1819.*

To my knowledge, the disease in turnips called *fingers and toes* has been known in Suffolk above

* It is highly probable that the remains of the animal matter of the larvæ in the diseased root afforded this additional quantity of albumen.

fifty years; and, I am informed, it was known long before that period. But I am quite unacquainted with the districts in which it first appeared.

I have not heard that this distemper has been particularly noted in the present season (1819.)

In all the observations which I have made on this distemper, it ever appeared so scattered as not to admit any generally operating cause, perhaps not more than a plant or two upon an acre of land; very rarely indeed in any continuity of effect.

In the remarks which have come to my knowledge, the disease has not appeared till the bulb of the root has been somewhat advanced. I do not recollect any appearance in the plants, at an early growth, indicative of the distemper; the termination of the disease is the reduction of the plant in size and value.

I have no idea as to the cause, for it sometimes comes so very thinly scattered in a crop as seemingly to authorise the supposition that the seed was not affected. The only remark that has been made here, relative to soil, is, that it comes more upon light sandy lands than upon other soils, and rarely when the sowing is late.

I never heard of the application of any remedy.

The disease has appeared on land that was never limed at all, in the memory of man. There is very little arable in this county (Suffolk) from old grass, it being prohibited in all leases.

I cannot learn that any satisfactory observations

have been made relative to variations according to the sort of turnip.

The number of plants in a whole field affected by this disease is so small, that it is impossible that cattle should have been hurt by eating the distempered turnips. I have known a field of several acres with only one or two of these *anburied* plants to be found in it.

No remarks have been reported to me sufficiently minute to ascertain any connection between the seed sown, and the distempered plants arising; but in a multitude of cases the number affected is so few that it is not easy to suppose it derived from the seed.

3. *From Messrs D. and A. MACDOUGALL, Cessford, by Kelso, Roxburghshire, dated 22d October 1819.*

WE offer the following answers to the queries proposed by the Caledonian Horticultural Society, in regard to the disease of Anbury, or "fingers and toes," in Turnip.

The disease has been known in this neighbourhood for nearly twenty years. It seems to have originated in the district, without any connection with any other whatever. It has greatly, indeed more than in any other district, injured the turnip-crop upon Harelwater, in Roxburghshire. In several instances, the whole field has been totally destroyed;

in others, only in patches; but never following the drills, so as to convince that it is caused by the seed, manure, or treatment of the land.

The turnip is attacked at a very early stage, even before hoeing in some cases, and in others not till the crop has completely covered the ground: in either case, the leaves immediately droop, and, if the weather is dry, the plant entirely loses its growth, and dies. If it is moist, it may not have much the appearance of the disease; and by putting out new fibres above the affected part, it in some measure recovers its vigour, and, although still diseased, attains to a good size; but invariably part of the root is in a state of putrescence, and, if exposed to the frost in winter, becomes entirely rotten.

We think the disease originates in the bite of some insect upon the fibres, more than the effect of either soil, season or climate, although the lands in a low situation are most affected by it; the excrescences are frequently so perfectly sound, as not to have the smallest appearance of animalcule seen in them with a microscope. In a short time they certainly are full of insects and worms; but we think the diseased state of the turnip produces them, and consider it to be first caused by a puncture, without any eggs being deposited in the turnip. Numberless remedies have been tried without any satisfactory result. The disease has appeared on all descriptions of land under every kind of management, —newly cultivated land, new-limed—old pasture

land, new-limed—crofts, limed and without lime, dunged, and without it.

We know no kind of turnip that is not occasionally affected by the disease. The Swedish turnip, from having a greater number of fibres, continues to grow after it is attacked; and, being of a much harder nature, is not so readily injured by the winter's frosts.

The turnip by the disease loses almost all its feeding qualities, and becomes very disagreeable both to cattle and sheep.

The disease has appeared in turnips grown from seed, raised under every circumstance; and we are convinced it is not the effect of the seed, as even the Wild Mustard (*Sinapis arvensis*), and runches (*Raphanus Raphanistrum*), seem to be attacked by it, their roots distorted, and their leaves drooping.

We know of no seed raised from diseased plants having been used; but cannot think it would affect the shape of the turnip, as many of those affected by the disease retain the same round shape which is found in the sound turnip.

It would be useless to attempt a description of the various appearances of the diseased turnip, as the gentlemen of the Society could form no idea of the matter from such a description—and can see the disease in every stage and appearance, by having specimens of the turnip sent to them, from the first formation of the tubercles, about the size of a small

pea, until the turnip becomes completely putrescent. —In writing answers to the queries of the Society, it may perhaps be expected to see a detailed account of the remedies used for the prevention of the disease. They were principally, using different kinds of manures, and pickling the seed before sowing. It has been asserted that marl is a remedy; but that can only be obtained in a few situations; and it certainly loses its effect in a short time, as many farms in this neighbourhood were marled not many years since, and are now liable to the disease. That the disease is occasioned by the deposite of eggs, seems to be confirmed by a circumstance that takes place here, of affected turnip having been carted to a part of a stubble-field, and given to some calves, which were confined by a railing; the other parts of the field were free from disease, and that where the diseased turnip was laid was completely covered with it.

4. *From the Reverend GEORGE JENYNS, Prebendary of Ely.*

I HAVE been honoured with your letter from Sir JOHN SINCLAIR, Baronet, requesting any information that I can give you upon the subject of a disease in turnips, called in Scotland Fingers and Toes, and with us the *Anbury*. I will endeavour

to answer the different queries inclosed in your letter, to the best of my judgment in matters of that kind.

First, then, the disease in turnips called *Anbury*, has been known in the eastern part of the kingdom as far back as forty years, to my own knowledge. It prevails generally this season to a great extent.

From whence it first made its appearance in this district I am not able to say, nor can I obtain any information upon the subject which can be depended upon.

The disease has prevailed this season (1819), beyond any other within my memory, not only in my own neighbourhood, but also in many parts of Norfolk, where I have very lately been.

The disease does not appear to be in patches, but to extend itself generally over the whole field. The turnip least affected is that which with us is called the *Pudding Turnip*, (a long turnip, two parts of three above the soil). This species, both white and blue, seems to have escaped the effects of it more than any other.

The disease attacks the turnips at different periods of their growth; but I think chiefly when they are young. It is observed in the foliage of the turnip very soon after it is affected. The leaves and the heart of the turnip curl up, and change colour to a yellowish tint, and at last fall off; and the turnip rots immediately; this does not happen in all cases.

It is a commonly received opinion in this part of England, that the disease occurs chiefly in a hot and dry season, such as have been experienced last year and this, more particularly to those turnips which were sown early. I do not believe that the quality of the soil, or manure, or newness, have any thing to do with it. I conceive it to be caused by a grub forming its nidus in the bulb; I have not traced the progress of the larva, so as to ascertain the species of insect, but a small maggot or grub is visible in every excrescence upon the turnip which I have examined; in some instances three or four very near together in the same lump. If it results from the puncture made by some insects, eggs must be deposited at the same time.

I know of no remedy which has been tried to prevent this disease in the turnips.

Being in Norfolk a few weeks since, I had the curiosity to observe the turnips raised after a wheat crop, and those sown upon an oat-stubble, from a common very lately enclosed, and of course pared and burnt for the oats. I evidently saw that the disease had not prevailed upon the common so much as on the old tilled land. This might have been accidental. But so it is, that the crop of Swedish turnips this year throw out the same excrescence as the common turnip, but contains in those excrescences several large grubs, very different from those in the common turnip. This disease has stopped their

growth ; but the Swedish do not rot in consequence of it, as the others do.

I much fear that this disease will materially affect the turnip as an article of food.

Turnips affected with the anbury are twisted, and curled about into all sorts of shapes, where the disease has attacked them early ; where it has been later in its appearance, the turnip is not mishapen. They are now rotting in this country very fast indeed, and I do not think that there will be many remaining after Christmas.

5. *Letter from the Right Honourable SIR JOHN SINCLAIR, Bart. to the Secretary.*

SIR,

I HAVE found some notes on the subject of your inquiries respecting the disease called "*Fingers and Toes*," to which the turnip crop is liable in some parts of the kingdom. I understand that the root of the cabbage tribe of plants is liable to a distemper somewhat similar, which is known under the name of "*The Club*." It is supposed to be occasioned by an insect, which eats into the root ; and it has been remarked, that those plants which have long dung deposited under them, are the most liable to it. The only remedy that has hitherto been

successfully used against this disease, is a liquid made with the following articles :

1 peck of lime,	} To a large tub of water, which should stand twenty-four hours after the ingredients are put into it, before it is used.
1 peck of soot,	
1 lb. soft soap,	
$\frac{1}{2}$ lb. shag tobacco,	
$\frac{1}{2}$ lb salt,	

A small quantity, poured from a water-pot, round the roots of each plant, has been found useful in destroying the insect, if applied early, that is to say, before it has eat its way deep into the root.

The success of this plan with cabbages, has given rise to the idea that a composition somewhat of a similar nature, might be of service in the culture of turnips. It would be impracticable to apply it to turnips in the same manner, namely, to each plant ; but where the manure is placed under the crop, according to the drill system, the dung might be watered with the liquid above proposed, before the manure is covered ; or the lime, soot, and salt might be mixed with the dung, in different proportions, so as to ascertain whether it is practicable, by such means, to prevent the disease.

I hope that some public spirited farmers will try this plan, in various modes, by way of experiment ; and will publish the results for the information and benefit of the public.

The following communication is by the Editor of the " Farmer's Journal" :

“ We have observed the disease called *Anbury** (or *Ambury*), only in very dry seasons, to any mischievous extent, and chiefly on sandy, or other thirsty and light soils. It seizes the crop soon after the bulbs begin to swell, and prevails in proportion to the drought, because the growth of the plant is slow ; if the drought continue, the leaves turn purple, then shrivel, and the plants die off at the root : thus whole crops have been nearly destroyed, but timely and plentiful rains would, in part, arrest the progress of the disease, and restore the crop.

“ It is doubtless occasioned by insects ; perhaps piercing the roots near the surface, and depositing their eggs, which, as in multitudes of other cases, produce knobs, and intercept the ascent of the vegetable nutriment (sap). If, when the disease has taken place, plentiful rains ensue, the bulbs put out other roots (or, more properly speaking, other fibres enlarge) to supply the place of those which are wounded.

“ There is another disease (if it be not the same) which attacks Swedish turnips, and cole (or rape) in fen countries, every year more or less, and every crop in a greater or less degree. It shews itself in knobs on the bottoms of the turnips, and on the upper part of the roots of the cole, each knob contain-

* The word is borrowed from farriery. *Anbury* is a name given to small knots or excrescences, warts or wens, on the legs or flanks of horses. They are generally small, and rather loose at the root, being seated in the skin.

ing a small white maggot ; the knobs are often very numerous and joined together, the ascending *caudex* of the cole root being surrounded with them ; and if great drought continue, the plants turn purple, then yellow, and apparently die ; but timely rains will check the evil, and, in some degree, restore the crop. We should have thought that these had been the *larvæ* of the *Jenny Spinners*, which afterwards become the common blue grub, but we have generally observed this disease at an earlier period than that in which those insects deposit their eggs. *Fresh burnt* land is by no means exempt from this attack, and we believe burning the stubbles could not prevent it, because, in either case, it appears to be caused by an insect on the wing. *Salt* is certainly the best hope of prevention, because it is very inimical to all reptiles of the insect tribe, together with slugs, &c."

LXVII.

*An Account of some Seedling Apples and Plums
which have been raised at Coul, in Ross-shire.*

In a Letter from Sir GEORGE STUART MACKENZIE,
Baronet, to the Secretary.

(Read 26th October 1826.)

THE *Kinellan Apple*, the *Tarvey Codlin*, the *Kerkan Apple*, and the *Achmore Apple* (the last not yet exhibited), sprang from seeds taken out of one apple, the produce of a blossom of the *Manx Codlin*, impregnated by the pollen of the *Nonpareil*.

The *Kinellan* is a large and handsome fruit, the tree a great bearer. The consistence of the flesh is melting, and much like that of the nonsuch. The flavour is good, and sharpened by acid, which renders this a very excellent kitchen-apple, and it keeps well till April. The fruit of this and the two next (the third has not yet borne a full crop) is remark-

able for the firmness with which it adheres to the tree ; a quality of a valuable kind in a country subject to storms in autumn.

The *Tarvey Codlin* is early in season ; it possesses a high and agreeable flavour ; but though it keeps long, the flavour disappears after a month or six weeks, though sometimes it is retained longer. It is rather a large fruit and handsome, and the tree a good, but not abundant, bearer.

The *Kerkan Apple* is a small fruit, and from its mildness and juiciness, is well suited to the desert. The tree is an extraordinary great bearer. In flavour, the fruit resembles a good deal the London Pippin. Its best season is November, but it keeps for several months well.

Of the *Achmore Apple* it can only be said that it promises well, its qualities not having yet been ascertained.

The *Contin Reinette* has been much admired as a dessert fruit, and the tree has proved a good and sure bearer. There is something in the blossom-buds that renders them attractive to bulfinches, which generally save the trouble of thinning. The buds, at the extremities of the branches, are almost always fruit-buds. The tree is of slender growth, and the fruit-buds differ from those of most other

apple-trees, in being slightly set on, and shaped like an egg, the obtuse end next the branch, but rather more sharply pointed than an egg. The season of the fruit is November and December. It is a very pretty apple.

The *Coul Blush Apple* is a most beautiful fruit, much resembling in its general appearance the Hawthorndean; and being of a better flavour, it may perhaps become the substitute of that old variety, which seems to be wearing out. Its size and beauty render it a very desirable fruit for the market. The tree is of strong upright growth. Fruit keeps till February.

The *Sweet Topaz Apple* is remarkable, as being entirely destitute of acid in all stages of its growth. When ripe, it is very saccharine, and has a pleasant flavour. It will probably find a place in almost every garden, on account of its remarkable sweetness, and as promising to be of much use in cider-making. It is rather a large and very pretty fruit, and keeps two or three months; but it is best at the time it is gathered.

The *Coul Orleans Plum* resembles very much in appearance the Red Magnum Bonum. It is certainly not inferior to the Old Orleans, and is rather a better fruit on the whole. It bears most abund-

antly, and for the market gardener no plum can surpass it, being quite hardy.

The *Coul Black Ball* is a small round plum, of a deep blue colour in the skin, with a green flesh. It bears well, and is a very sweet fruit ; also hardy.

The *Achmore Plum* is very like the Old Magnum Bonum, but not quite so large, and bears well ; and is harder than the Magnum.

When seedling fruit raised in Scotland are really good, and especially when found to ripen well on standards so far north as Coul, the latitude of which place is $57^{\circ} 34' 54''.5$, they should be preferred to others of a southern origin, which are less suitable to our climate. The trees carrying the fruit described above, are all healthy and hardy.

There is a gooseberry of great merit at the same place, produced from seed five or six years ago, called the *Rob Roy*. It is pale red when ripe ; and indeed appears, when it is in perfection, like a half ripe red gooseberry. It is early ; and has been ranked among the select sorts in the catalogue of the London Horticultural Society.

Except the two last mentioned plums, all these new fruits have been sent to the Experimental Garden of Edinburgh ; but as the trees are young,

grafts cannot yet be taken from them. Application for them from the original trees, made through the Secretary, will, however, be attended to.

Additional Communication.

HAVING sent my seedling apples to London, it may be some satisfaction to you to know, that the Contin Reinette has been deemed the best, as it was by your Committee. The words are, alluding to the whole collection, besides the seedlings, "As specimens of fruit ripened in Ross-shire, they were of a very remarkable character. The Tarvey Codlin, Coul Blush, Kinellan Apple, and Contin Reinette, and the Cambusnethan Pippin, were fruit of extraordinary beauty, and possessing the rare merit of hanging on the tree, notwithstanding the high autumnal winds to which they are exposed in the high northern latitude of the country in which they are cultivated. The Cambusnethan Pippin, and Contin Reinette, proved, on being tasted, to be table fruit of the highest excellence, especially the last mentioned sort." I think you should add this to your own report, as confirming your judgment. I am, &c.

COUL,
1st December 1826.

LXVIII.

*On Canker in Fruit-Trees depending on bad
Subsoil.*

In a Letter from MR PETER CAMPBELL, Gardener at
Coalston, to the Secretary.

(Read 4th December 1828.)

SIR,

I OBSERVE by the Caledonian Horticultural Society's prize schedule for 1828, they wish a communication ascertaining what the canker in the bark of fruit trees proceeds from.

That disease, as far as I can think, is owing to a stuntedness that takes place in the trees from a bad subsoil, and the ground not being properly prepared before the fruit trees are planted. An experiment I have tried, proves to be an effectual cure for that disease, as far as I have experienced as yet ; for the trees I have tried this experiment upon, are at present as healthy fruit trees as in East Lothian, making fine young wood, and at the same time producing good fruit, and very abundant crops at Coalston. There were upwards of seventy espalier fruit-trees taken

out for the canker, that had entirely given up bearing; and twelve of them had only been about twelve years planted. There were two trees of the Royal Pearmain Apple that I had a great anxiety to save, and these two trees let me into the secret where the disease proceeded from.

In January 1824, by examining the trees, I found that most part of the standard and wall fruit-trees, as well as the espalier trees, were going entirely to ruin by the canker, and all growing over with moss or lichen, some of it measuring four inches in length. Taking into consideration how to rescue them from that unhealthy state, I thought it proper to examine what the subsoil was where the trees were planted, that were most given to canker, and I found it to be of a sandy nature. By examining farther, there appeared some small particles of clay of a reddish colour, but not above the twentieth part of clay that there was of sand. It is to be observed, that amongst these there were veins of black sand, about eighteen inches below the surface, as black as ink. The only reason I can give for these veins being so very black is, that the part of the garden where the trees are that were most given to canker, was formerly a bog, and full of springs or spouts. By examining the roots that went down into these veins of black sand, I found them to be quite of a different appearance from the other roots, and even some parts of the same root quite swelled and overgrown, compared with the other

parts of the same root, so that the root had more the appearance of a tuberous than a fibrous root. I then examined the bark of the same sort of roots, which I found quite equal in thickness; but by examining the inner part of the wood of the root, I found, in the thick part of the root, near the heart, on one side of it, about one-fourth part of the wood of an iron colour and very hard, compared with the wood that was of a natural colour.

I then thought that the only means to improve these trees, and get them into a healthy state, was, in the first place, by commencing to get the mould cleared away from the roots with care, so as not to injure the roots; first to the distance of three feet out from the trunk of the trees all round, clearing all the mould that distance out, and even below the trunk of the tree, to the depth of one foot six inches below the under part of the trunk; however, the depth I made greater or less as was required, according to the state the roots were in. I cut the tap roots that went right down. I then made two ruts opposite each other, as low as the under part of the trunk, so as to place a beam of wood across below the trunk, and to prevent it from sitting down or sinking, owing to its being so much hollowed out below. I then cut off all the roots I thought diseased, and cleared the mould out another foot distance, which was four feet out from the trunk all round. Having no flags, I floored the pit I made below the roots with bricks and large slates laid close

together, so as to prevent the roots from entering into the black sand again, and formed the flooring of a concave form rather than even or level, so as to make the roots or young fibres incline upwards, which is a great means to prevent the roots from entering so soon into the subsoil. I mixed good mould with very rotten cow-dung, and filled up the pit with it, at the same time beating in every course below the trunk of the tree, with the end of a beater made for that purpose, so as to prevent the tree from sliding down too hard on the beam of wood.

This operation, if possible, should be avoided in high winds, particularly in dressing the roots of standard trees, as the wind playing on the tops of the trees in the loose state they require to be in, might be a means of injuring the roots.

The second operation is the pruning of the tops of the trees. I commenced on one side of the trees, and pruned regularly round, cutting off all the cankers, not leaving one branch or bit of wood that had a canker in it on any of the trees. In some of the trees, I pruned two-thirds of the wood, others I pruned, leaving only one-fifth part of the wood, which operation was executed according to the state the tree was in.

By this treatment, the trees are become quite healthy and free of any moss or lichen, and not the least appearance of a canker, where formerly every year's growth cankered the second year, and had done so as far as I could observe, by numbering the

growths or shoots, for ten years back. I have done espalier, wall and standard apple trees in the mode before stated; and I shall send specimens of the Dutch Codlin off a standard, Royal Pearmain off an espalier, Paradise Pippin and Summer Strawberry off the wall, both on a north aspect. It is to be observed, that all the trees (excepting the Royal Pearmain) are above forty years old.

Should you consider the above communication of sufficient importance to be attended to, I hope you will have the goodness as to lay it before the General Meeting of the Caledonian Horticultural Society, in the beginning of December. I am, &c.

COALSTON, }
29th Nov. 1828. }

LXIX.

*On the Germination of Seeds and subsequent
Vegetation.*

In a Letter from JOHN MURRAY, Esq. F. L. S. to the
Secretary.

(Read 7th June 1827.)

DEAR SIR,

I TRUST the following detail of some experiments on the germination of seeds and subsequent vegetation, may not be unacceptable, or void of practical value. If you should be of this opinion, be so good as to submit the communication to the Caledonian Horticultural Society.

Mustard and cress seed were sown on black woollen cloth, kept constantly wet. The germination was tardy, the growth exceedingly dwarfish, and the vegetation altogether sickly. Seeds from the same packets, grown on patches of white and of red woollen cloth, were luxuriant and beautiful. The comparative temperatures of the several pieces were, black $48^{\circ} 5'$ Fahr., white $48^{\circ} 5'$ Fahr., red $49^{\circ} 5'$ Fahr. The difference of temperature

might occur from the evaporation being modified by the colour and texture of the cloth, or the comparative degree of evaporation proceeding from an inequability in the supply of water : the retardation and final suspension of the vegetation are no doubt to be ascribed to the *iron*, the base of the colouring matter in black.

Mustard and cress seeds were sown in powdered alum, sulphate of iron, sulphate of soda, sulphate of magnesia, muriate of soda, and muriate of lime, in small glass capsules, and duly watered, with the exception of the *last*, which being a deliquescent salt, did not require it ; two cress seeds only germinated in the powdered alum, but vegetation was not declared in the others.

Mustard and cress seeds were partially roasted, by being projected on ignited iron, yet a great portion of them afterwards grew on wetted flannel. Seeds were likewise submitted to the action of boiling water, and the temperature suddenly reduced : all these grew. Hence some seeds can sustain an elevated temperature without the destruction of their vitality.

Peas and beans, with boiling water poured on them, and suffered gradually to cool, sprouted in a few hours, and grew remarkably well, having been transferred, when cold, to wetted flannel : this experiment furnishes a very easy method of ascertaining, in a sufficiently prompt way, whether the vegetative power is suspended, by age or other causes.

I put sprung peas into alcohol, of specific gravity .812, but little progress was made in ten days: those placed in naphtha and ammonia decayed. Peas introduced into alcohol, naphtha, and sulphuric ether, exhibited no evolution of incipient germination.

Mustard and cress seeds were sown in iodine, dilute sulphuric acid, dilute muriatic acid, and dilute nitric acid, chlorate of potassa, hydriodate of potassa, muriate of iron, sulphate of iron, and caustic potassa; they gave no evidences of germination whatever, though they were regularly supplied with water.

Cress sown on carbonate of magnesia, and attentively watered, germinated freely: hence there must be some error with the late Mr Tenant's conclusion, as this experiment is completely opposed to his deductions. It is one of first rate importance, as many farmers have been induced, from Mr Tenant's experiment, to discard magnesian limestone as injurious to vegetation, though they had a supply of it at hand, and bring from a distance lime-stone of a different character.

Mustard germinated freely in the tincture of iodine, and the vegetation was fine.

Tufts of mustard and cress, growing on different parcels of sponge, were placed in capsules with the following solutions:

Sulphate of iron (copperas); vegetation here fell the *first* victim.

Sulphate of copper (blue vitriol); this fell the *second* in succession.

Acetate of lead (sugar of lead); this fell the *third*.

Muriate of mercury (corrosive sublimate), was the *last* survivor.

Some younger plants, though nearer the surface, sustained the green colour after the tallest had fallen, but cress seemed to be the last to suffer. The vegetable matter in each instance was duly tested by the necessary reagents. That with sulphate of iron, after the stems had been macerated with distilled water, became decidedly blue with hydrocyanate of potassa; that with muriate of mercury was rather equivocal on being examined by caustic potassa. In the specimen destroyed by sulphate of copper, the lower parts of the stems, and transverse portions, where they were cut, became of a violet tint with ammonia. The vegetable matter that had been destroyed by acetate of lead, tested with hydriodate of potassa, was not appreciable; but on being crushed in solution of chromate of potassa, the capillary vessels were beautifully dyed by the new formed chromate of lead.

These last experiments prove that vegetation is affected by the metallic poisons, sulphate of copper, acetate of lead, and corrosive sublimate, and perish under their influence. They also prove that ferruginous matter holds the first rank in these deadly

poisons; and, in this respect, there is a difference between animal and vegetable life. When iron obtains in any soil, there is an enemy to contend with, and sand and lime, in due proportions, appear to me to be the only remedy; the lime decomposing the salt of iron, and the silica combining, in the character of an acid, with the oxide thus separated: such a combination we find in the baths of Lucca, &c. The experiments also shew the comparative fatality, and yield decided evidence of the passage of the substances into the system of vegetable being; and, of necessity, their consequent absorption by the roots; the young stems having been always cut above the surface the sponge, and apart from the roots. It is not, therefore, the mere root that is affected, but the entire plant in its higher organization.

Tufts of vegetation, similar to those already described, were placed in capsules with the following solutions: dilute nitric acid, hydriodate of potassa, and chlorate of potassa. These are arranged in their relative order as to their comparative permanence, the tuft placed in dilute nitric acid having fallen first, and that in chlorate of potassa remaining longest unaffected. The stems of that with nitric acid, slightly reddened litmus paper, when macerated in distilled water; that in hydriodate of potassa gave an abundant yellow precipitate, with acetate of lead; and that from chlorate of potassa deflagrated like nitre, on an ignited disc of platinum.

I would not, however, be supposed as inferring

from the last experiment, that, though chlorate of potassa does in quantity injure vegetation, when thus applied to the roots, a small portion in solution might not occasionally be beneficial, and act, in some plants at least, as a stimulus to vegetation. Last season, when all my carnations seemed rapidly proceeding to destruction, in consequence of the arid summer (1826), and many had already perished, I succeeded, by a few waterings with solution of nitre (an analogous salt), not only to save the remainder, but to impart to them a beautiful luxuriance and growth. The effect was very manifest, and remarkably prompt; and I now possess a hundred very beautiful plants.

EDINBURGH,
26th April 1827.

LXX.

Account of the Mode of Culture adopted at Cunnoquhie, in raising Pine-Apples and Melons, in a Pit heated by Steam ; with a Description of the Pit and Steam Apparatus.

Communicated by Mr ALEXANDER SMITH, Gardener to
Colonel GEORGE PATERSON of Cunnoquhie.

(*Read 4th December 1828.*)

THE Caledonian Horticultural Society having approved of the fruits raised at Cunnoquhie, and expressed a wish to have an account of the method of culture, the following is submitted to their attention.

It may be proper however to premise a short description of the Pit and of the Steam Apparatus.

The pit was erected in 1824, on a plan furnished by Mr John Hay, planner, Edinburgh, founded on a principle of heating, devised by Mr Hay more than twenty years ago. The pit is built of brick; it is thirty

feet long, by nine broad, and about five high ; and is divided into two parts ; one of which, consisting of four lights or sashes, is appropriated to melon culture ; the other, of five lights, to that of pine-apples. Another smaller building, erected in front of the former, and on lower ground, contains the apparatus for preparing steam. This consists of a cast-iron furnace, with a copper boiler, capable of containing about sixty gallons of water, and communicating by a pipe and stop-cock, with a large tube, which lies lengthways in the floor of the pit. There is also, besides the boiler, a cistern, communicating by a ball-cock with another at a distance, and keeping by that means an equal supply of water, to replace what is given off in the steam.

The large iron-pipe, which receives the steam from the boiler, is perforated at certain distances, (2 feet), with holes for diffusing the vapour through the pit. It is surrounded by a layer of small water-worn stones or pebbles, with which the floor of the pit is filled to the depth of two feet. Over these is placed a cover of Arbroath pavement about three inches thick, supported on brick pillars, and extending on each side nearly to the outer wall. Intervals are left between the edge of the pavement and the wall, in order to allow the steam to communicate with flues which are filled, like the bottom of the floor, with small round stones. At short distances, on the top of these flues, are fixed small iron tubes with caps which are removable

at pleasure, and admit or exclude the steam of the flues and floor from the atmosphere of the pit, as occasion may require. The outer wall, on each side, adjacent to the flues, is built double, with a small interval between the parts, which prevents unnecessary waste of heat, and allows any heated air or steam which may escape through the interstices of the bricks to pass into the atmosphere of the pit. It should be mentioned, that though, for simplicity, the frame is described above as single, yet there are, as has been stated, two parts; one for melons, and another for pines; in each of which the steam, by means of distinct stop-cocks at the boiler, may be admitted or excluded separately; the tube being for that purpose in two separate pieces.

Mode of Culture for Pine-Apples.

Soil.—The soil which is used for repotting the plants for fruiting, is one-half loam, one-fourth vegetable mould, and one-fourth hogs' dung. These are well mixed with the spade, but not made fine or sifted. The pots are placed on a layer of cinders four inches deep, which lies next the Arbroath pavement; and they are plunged as high as their edges in good tan-bark. They are never moved, except for repotting.

Temperature.—In winter, the temperature of the atmosphere of the pit is kept at 50° or 55° of Fahr.; the steam required to produce this effect is

about one and a half hour in twenty-four. The vapour is not at this period admitted among the plants, the caps of the flues being kept uniformly shut. This treatment is continued till about February.

About February, the temperature is raised to 70° during night, and about 65° in the morning. The steam-caps of the flues are sometimes taken off towards morning, admitting to the plants what vapour may have remained in the pit over night.

In May, or when the flowering is over, the steam is frequently admitted to the atmosphere of the pit through the whole night. This seems to destroy insects, and to keep the foliage of the plant in a state of fresh and healthy verdure. The temperature is now about 75° or 80° degrees, and steam is applied when artificial heat is necessary to maintain that degree of heat, which, in very warm weather, is only about once or twice a week.

In autumn, while the fruit is ripening, steam is only applied once in forty-eight hours; and the temperature of the pit is kept nearly at 65° or 70° . We have fruit generally from the plants in their second year.

In all cases, fire is applied to the boiler about six o'clock in the evening, and steam is procured a little before seven. The quantity of fuel used has not been exactly ascertained; but from the construction of the furnace, with flues round the boiler, &c. every economy of heat is practicable, and the quantity of coals used is the less. Those which are employed

being generally the refuse left from other purposes, less attention was paid to taking any account of the quantity.

In the season 1826, by the above mode of culture, we had nearly twenty pine-apples; one of them, a Queen Pine, weighed four and a-half pounds*. And the result of the whole experiment is so satisfactory, that Colonel Paterson intends this season to have a considerable enlargement of the pit on the same plan.

Mode of Culture for Melons.

The soil used for melons, is four parts strong brown loam; two parts light loam; one part vegetable mould; and one part rotten dung. These substances having been intimately mixed, are put into the frame above a layer of cinders four inches thick, which is to be placed next the pavement. When the plants are put in, steam is to be applied once in forty-eight hours, one and a half hours at a time. A very little watering is necessary, till the fruit be set; after which it is to be applied more freely. From the time when the plants appear, to the setting of the fruit, the heat is kept near 60°; and afterwards about 65°. In warm weather, steam is required only about once a week.

* Specimens of the pine-apples and melons raised in the Cunnoquhie pit, were exhibited to the Committee of the Society, 2d October 1828, and greatly admired. P. N. Sec.

In the season 1826, from seven lights or sashes, we had seventy-six large melons, cut from the pit ; one of them weighing ten pounds. It may be mentioned, that during the winter season, when the pit is not in use for melons, it may be employed to raise early crops of potatoes, asparagus, sea-cale, or small sallads*.

CUNNOQUHIE, }
22d Oct. 1828. }

* The Society's Silver Medal was, 5th March 1829, awarded to Mr Alexander Smith, for this communication, and for the fine specimens of fruit sent to the Society in October last, evincing excellent culture on the part of Mr Smith. P. N. Sec.

LXXI.

Account of a Glazed House, adapted for the Culture of Peach-trees, Grape-vines, and Ornamental Plants.

By Mr R. F. D. LIVINGSTON, Planner.

(Read 5th March 1829.)

THE favourable manner in which the Horticultural Society were pleased to receive the section-plan of a greenhouse, or hot-house, designed by me for James Smith, Esq. of Smith's Place, Leith Walk, and exhibited at the last Quarterly Meeting of the Society, induces me to draw up a few remarks connected with the utility and management of the house.

The house is forty feet long, by sixteen wide. It is heated by one furnace, situated at the east end. The first course of heat is carried immediately under the pavement to the front flue, by ascending into which, it rises one foot in the angle, two feet from the front, and the same from the end walls. It is carried along this flue thirty-six feet, descends under the pavement at the west end, and again rises two feet

perpendicularly into the back flue, five feet from the end wall, and four from the front flue. This part of the flue is thirty feet long, and descends in like manner under the pavement at the east end, through which it passes into the chimney situated immediately over the furnace. It thus makes a circuit of one hundred feet, chiefly round the front half of the house. By this arrangement of the flues, I considered that the house would be much more easily heated, and kept in a more regular temperature, than by the ordinary methods; and during the late severe frosts (January 1829), which have been sufficient for a fair trial, the design has proved efficient even beyond my expectation.

The stage occupies a space of thirty feet by eight, leaving a space of five feet at each end, which, by a partition of ornamental lattice-work, the full height of the glass and width of the stage, forms these spaces at each end into two very neat lobbies. These are appropriated to the growth of the finer sorts of climbing plants; and the stage is capable of containing from 800 to 1000 plants in pots.

The peach-trellis occupies the whole length of the house, and contains a surface of about 280 square feet, to which the trees are trained. The front wall is arched, and a prepared peach-border is made for the roots, two feet wide inside, and eight feet wide outside, and four feet deep.

A shelf of eight inches width is erected immediately under the sloping rafters in front, princi-

pally for the purpose of holding strawberry-pots, the fruit of which may be brought to perfection here at an early season, with very little trouble. At other times, the shelf may be useful in holding Cape bulbs, seedlings, and other dwarf plants.

In forming the vine-border, I have departed from the usual course, and have placed it at the back-wall of the house. It is a well known fact, that the vine-border should be entirely given up for that purpose, without even producing the slightest annual plant on its surface, and that it should be inaccessible to over-abundant quantities of water, at all seasons, but more particularly in the early part of the flowering and fruit-setting time; in a word, that they should be so situate, as the industrious gardener may only apply such waterings, and in such quantities, as may seem proper and reasonable to regulate his successful endeavours in producing a superior fructification. From the extreme delicacy of the vine at particular seasons, a dry situation must be considered the best, and, to obtain which, the judicious gardener forms the vine-border into a sloping bank in front of the vinery. In the present design, I beg leave to submit, that the former difficulties are obviated, and that the main end is obtained, by forming the vine-border entirely under cover of the house. By this plan of having the vine-border at the back of the house, I gain the site in front for a peach-border, without the vines in anywise interfering with the growth of the peach-

trees; and as vines seldom produce any fruit below the top of the upright rafters, which is the only space occupied by the peach-trees, it is thereby shown that the space occupied by them is entirely gained in this off the usual arrangement of hot-houses.

At the letter D in the plan, is observed the pavement of the gangway, which allows a space of three feet between the back flue and peach-trellis, elevated eighteen inches above the level of the lobbies, and the same length of the back flue and stage, thus affording an easy command over the stage and peach-trellis, and ascended by two steps at each end.

Supposing the house to be now filled with the proper quantity of vines, peaches, and greenhouse plants; in the autumn, as soon as the vines were ripe, they should be let out of the house, by sliding down the lights, one at a time, in the fore part of a mild day, and the vines fastened carefully to the back wall, there to remain during the winter, or until the time of forcing arrives, when they may be taken in again, observing the same caution as before. The usual progressive degrees of heat are then to be attended to, as in the ordinary mode of *peach forcing*, which is the principal object here to be attended to; and such will perfectly suit the vines. I would recommend the 1st of March as the best time to commence this work.

By the same progressive stages of temperature, the ornamental plants will flourish and produce early

flowers, which may either remain in the greenhouse, or be successively removed to decorate the drawing-room, &c. About the middle of May the plants will be turned out for the summer, and the stage may then be appropriated to dwarf-vines, in pots, figs, balsams, and other tender annual plants.

Section Plan of the Greenhouse, at Smith's Place, Leith Walk.

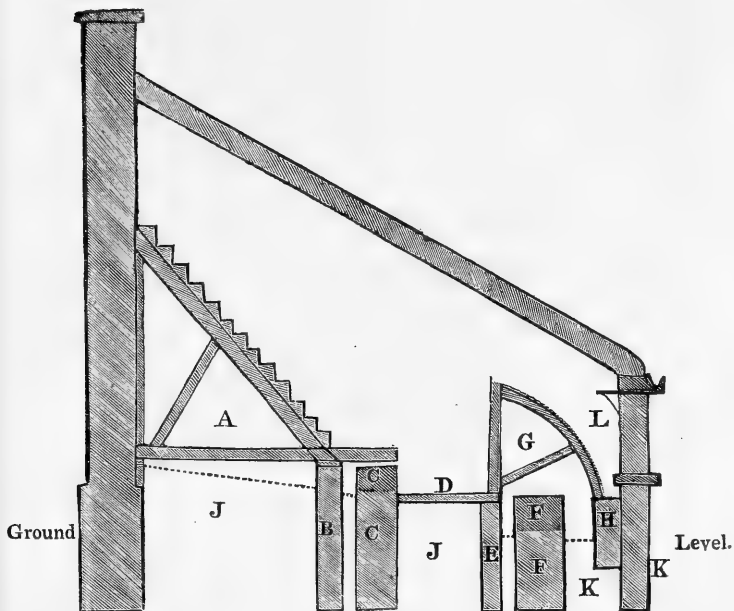

- A Stage for plants.
- B Arched wall for support of stage.
- C Arched wall and back flue.
- D Raised walk or gangway, in front of stage.
- E Arched wall for support of walk.
- F Arched wall and front flue.
- G Peach trellis.
- H Stone for support of peach trellis.
- J Made border for vines ; it is fourteen feet wide, five feet deep at back, and three at front : here the vines are planted against the back wall, and trained down the rafters, one branch to each, on the spur mode of pruning.
- K Peach border.
- L Front shelf, for forcing strawberries, &c.

LXXII.

Account of a mode of producing a steady and uniform Bottom-Heat in Pine-apple or Melon Pits, or in Stoves for Exotic Plants, by means of Steam introduced into a close chamber filled with water-worn stones.

In a Letter from Mr JOHN HAY, Planner, Edinburgh, to
Mr NEILL, Secretary.

(Read 5th March 1829.)

HAVING for many years back paid considerable attention to the heating of hot-houses by steam, and more particularly to the application of it, for the purpose of obtaining bottom heat, for the culture of the pine-apple and melon, and other tender plants, in a more economical and effective manner than has been hitherto practised, I am again induced to lay before the Caledonian Horticultural Society the result of my farther experience and improvements in the construction of such buildings.

In the year 1820, I communicated to the Society a paper on this subject, which is printed in the

third volume of their Memoirs. In that paper I stated the origin of the idea, which first occurred to me about the year 1794, when employed in erecting the hot-houses in the gardens at Prestonhall, and pointed out the manner in which it was applied, and its results. I also entered into the description of a set of steam pine-pits at Bargany and Castle Semple, in which the same principle is adopted in a more improved form, and attended with ample success. But what I have principally in view in the present communication is, to describe a further improvement in their construction, the result of which promises to be of considerable utility, especially in the hands of intelligent and enquiring horticulturists.

In the year 1807, I had the honour to be consulted by his Grace the late Duke of Northumberland, with a view to rebuilding the hot-houses at Alnwick Castle, which then chiefly consisted of grape and pine houses, and was desired by his Grace to furnish him with plans for executing the work on the most approved principles. His Grace directed me to provide for the heating of one of the pine-stoves by steam, as he had seen an attempt of this kind made in Scotland a number of years before; the particular place was not mentioned. The Duke's desire to have one of his pine-stoves constructed, with a view to attain this object, led me to consider the subject attentively. It occurred to me that a close chamber below the pit filled with stones

and heated by steam introduced among them, from a boiler placed at a short distance, would answer the purpose ; and in this manner one of the stoves was accordingly designed and executed. But the pit was of large dimensions ; and the steam-pipe, which had also to supply other two houses, being only two inches bore, was found insufficient to give out the portion of steam necessary fully to effect the heating of the mass of stones under the pine-pit. The apparatus in this case, not being quite perfect, the use of it was not long continued. I did not, however, lose sight of this principle ; and accordingly in 1818, in erecting pine-stoves at Castle Semple, small pits were built in front of them, in one of which an improved steam chamber was constructed, furnished with a boiler and proper pipes and apparatus for heating it, in every respect the same as I have more recently applied them. Nearly about the same time, I was requested by Sir Hew Dalrymple Hamilton, to give him advice regarding the improvement of his pine-stoves at Bargany, which were not doing well, and particularly to obviate the great difficulty and expence of obtaining tanner's bark. To accomplish this, I had no hesitation in adopting the very same plan I was then putting into execution at Castle Semple. I could depend on Mr Dodds, the gardener at Bargany, paying due attention to the subject, and giving me an accurate report of its utility ; after a year and a-half's trial, he accordingly wrote me his opinion, which is

published at length in the Memoirs, in the paper already alluded to. This report satisfied me of what the chamber itself would do, without the adjunct of stones.

In prosecution of the object which I had all along had in view, about the end of the year 1820, I caused the chamber of the steam-pit, which I had erected at Castle Semple two years before, to be filled with stones, those of the larger size below, and the smaller above. About this time I entertained the idea, and suggested it to the late Mr Harvey, that in such pits prepared with suitable compost, the pine-apple might be cultivated in the earth without pots as in the West Indies, by growing the plants for one year in the pit, and bringing them to fruit in the next, and so on alternately. With this in view, experiments were instituted to ascertain the difference of temperature communicated to the soil above, by the chamber without stones, and by the chamber with stones, and its duration. The result was decidedly in favour of the latter method, as it was found to retain the heat much longer than the other, as indicated by the steam-pit thermometer. So far I was satisfied with the application of the principle which I had long had in view; and in order further to try its effects, I caused the gardener to make up a bed of suitable compost in a part of the pit, and desired him to plant in it some of the smallest pine-apple plants he had, such as the suckers from the bottom of the fruit, only a few

inches high. On my return to Castle Semple, the following autumn, I was surprised to find that the plants had made far greater progress than I expected, being more than double the size their treatment by the old method warranted me to look for. I may here observe, that, if the plants will grow freely under this treatment in such pits, I have strong hopes that, by keeping the fruiting plants under a moderate degree of bottom heat during the winter months, and raising it considerably higher in spring, they would start regularly into fruit; and if this were found to be the result in practice, the views I originally entertained on this point would be realized. I now became fully convinced of the value and importance of this method of applying heat for the cultivation of *Ananas*, and resolved thereafter to adopt it in all practicable cases. It is but justice here to say, that, to the late and present proprietors of Castle Semple, the merit is due of seconding my views, and risking the expence of bringing this mode of heating to some degree of perfection.

More than six years ago, I proposed to Major Harvey to heat the fruiting-pit in the pine-stove in the same manner; and the cast-iron pipes and flags were consequently ordered, and sent to Castle Semple; but before the proper season for doing the work arrived, he had turned his thoughts towards making a new garden, and removing the old one. This in the mean time put a stop to the work, and the pipes

and other things prepared for the purpose were laid aside ; however, these and others have been since made use of in heating, on the principle originally contemplated, above sixty feet of pine-pits now erected at Castle Semple. The pine-stoves there have now been in operation for two years and a-half, with the most complete success. In a letter from Mr Lauder, the gardener, lately received, in answer to some queries I had proposed to him, he states, that the pines are as successful in the steam-pits as in those wrought with leaves, and with only one-tenth part of the expence ; as, in the one case, the plants never require to be removed during the whole year for the purpose of renewing the heat, while, in the other case, viz. the pits wrought with leaves, they require, he says, to be turned over, and new leaves added five times in the year ; and it takes seven men, for two days each time, to perform this operation, that is, on the two pits. He states, also, that it is his intention this spring, (1829), as I recommended two years ago, to plant one-half of one of the steam-pits with plants, not in pots, but in a bed of soil made up for them, and to fruit them the summer after the next. The steam, he says, is admitted into the chamber among the stones only an hour and a half in every forty-eight, which he finds to be quite sufficient to keep up the bottom heat as high as is necessary. During the winter, he has not admitted the steam for so long a period, having only kept the heat to the bottom of the pots from 75° to 80° ; but now, as he

wishes to start the plants into fruit, he intends to raise it to 90° . Each of the steam-pits is furnished with a thermometer, the same as represented in Plate XIV. Fig. 3.

The boiler at the stoves is three feet six inches long, and two feet six inches wide. Ten inches depth of water are always allowed to remain in it. It is prepared for four pipes, one for every pit, two of which only are as yet applied. The smoke from the boiler-flue enters a horizontal flue within the stoves, and goes more than half way round each; and as the flues have dampers, it may be turned into any of them at pleasure, so that no heat is lost. With regard to the expence of fuel for this boiler, Mr Lauder, in a report he made to me lately, states that it is only necessary to apply the steam to the pits once in every forty-eight hours, or 182 times for the whole year, the same for summer as for winter; but for three months in summer eleven times may be deducted, making the number of times that fire may be used 171. It requires an hour of fire to raise the steam in the boiler. The steam is applied to each pit an hour and a half, being four hours of fire each time. It takes one and a half imperial stones of coals every hour to keep up the steam, or 84 lb. for each period of four hours: this multiplied by 171, the number of times the steam is required during the year, gives $128\frac{1}{4}$ cwt., which at $2\frac{1}{4}$ d, comes to L. 1 : 4 : $0\frac{1}{2}$, the cost of coals for one

year. Mr Lauder calculates the coals at half price, being the refuse of those that are used at the house.

One of the chief advantages of heating by steam is, that the plants never require to be removed out of the house; and, therefore, the fruit is not in danger of being checked while swelling. When shifting is necessary, that can be done within the house, and the plants can be repotted one by one, and immediately restored to the places they were taken from, without being exposed to a lower temperature. But ananas cultivated by the usual method in leaf and bark beds, are subjected to many disadvantages, to which they are not liable in a bed heated by steam. For instance, before the heat of the bark-beds can be renewed, the plants must be all taken out of the pits, perhaps carried to some distance, and stand twelve or fifteen hours in a cold shed; and thus the plants, if in fruit, often receive a check which sometimes prevents the fruit from swelling off.

In the year 1824, Colonel Paterson of Cunnoquhie applied to me to give him plans of a set of pits in which melons could be cultivated without having recourse to stable dung. These were given and executed solely for the growth of melons. When they were finished, I was asked whether the pineapple would grow and fruit in them also. It was stated, that the application of the principle was the same for them both, and that the one would succeed as well as the other: but as the pits, in this instance, were designed for melons only, there would not be

head-room enough for pine-apple plants, unless the pots were plunged as low in the pit as possible. The trial was made, and melons and pine-apples were both grown in the original pits. The success of the Colonel's gardener, Mr Smith, as a cultivator of these fruits by means of steam, has been already made known to the Society, and specimens of the produce of these steam-pits exhibited. The Colonel was so highly satisfied with the result, that he consulted me, in July last, about making such alterations on his pits as would enable him to grow pines regularly, and also about making additions for growing melons. The plan and sections now laid before the Society are the westmost divisions of his melon and pine pits, as they now stand finished and improved. The other two divisions are now erecting at Cunnoquhie.

Melon-pits, on the same principle, were put up by me some years ago for William Younger, Esq. of Craigielands, in Dumfriesshire; and I have made plans of others for a gentleman in a different part of the country, which are not yet executed, but in which some improvements have been introduced. The plans now presented have been made to embrace these improvements; all which are described in the explanation of the plates.

EDINBURGH, }
4th March 1829. }

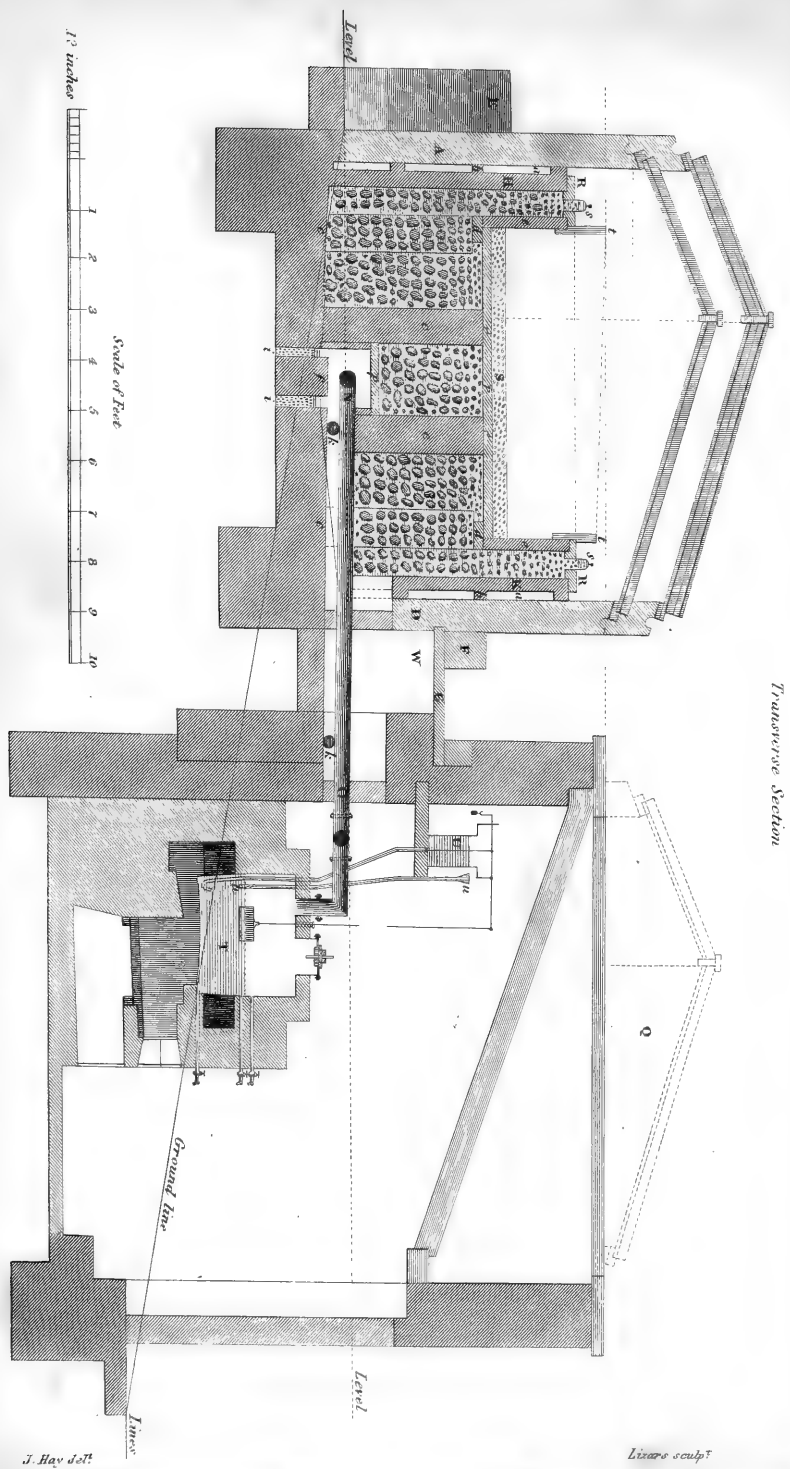

Transverse Section

L. Vase sculpt

J. Hay del

12 inches

Scale of Feet

Level

Level

Ground line

Lines

EXPLANATION OF PLATES XIV. & XV.

(The same letters of reference apply to the corresponding parts both in the ground plan and the section.)

ABCD, The external walls of the pits, built of droved ashler, 8 inches thick. In the upper course of ashler on both sides, are gutters for carrying off the rain-water from the roof sashes. The drawing is 10 feet over the walls.

E, An elevated walk with steps, on which the gardener may stand with ease, and do any work in the pits.

F, a step for the same purpose. **G**, a paved or gravelled walk,

HIKL, Wall of steam-chamber $4\frac{1}{2}$ inches thick, of square stock bricks, closely jointed with Roman cement.

a a, Open space $1\frac{1}{2}$ inch, between the inside of the external wall and that of the steam-chamber, the projecting parts *b* in the section being the ends of bricks built out of the walls of the chamber in an irregular manner, so as to touch the outer wall, for the purpose of strengthening the inner one; but these must not be so numerous as to prevent the heat from rising and diffusing itself freely through the pits.

c c, Brick pillars, 9 inches square, supporting the cover of the steam-chamber, &c.

d d, Pieces of rough flags, 6 or 7 inches broad, and 3 thick, lintelling over the open space between the brick pillars, and supporting the inner wall of the steam-flue *ee*. This wall is 3 inches thick, built of stock-bricks, and closely jointed with Roman cement. The depth of the plant pit is 20 inches.

ff, A course of bricks, 9 inches broad, for the seat of the steam-pipes. On each side of this is a gutter 3

inches broad, and the same in depth ; the floor of the steam-chamber has a rise of 3 inches on both sides, from the edge of the gutters to the outer walls ; and is paved with hard common bricks laid in lime. The upper bed of the lintel *dd* is 2 feet 10 inches in height, above the floor of the pit at the wall.

MNO, Cast-iron steam-pipes, of 3 inches bore (in some cases they are $3\frac{1}{2}$ inches), on the opposite sides of which, a line of half-inch holes *gg*, are bored at 2 feet distance from each other, in quincunx order : there is thus one hole for every foot of pipe in length.

h h h, Cisterns cut out of solid stone, 6 inches square, and 6 deep, having grooves $\frac{1}{4}$ th inch deep on the top of the opposite edges at the gutters. As the ground on which the pits are built falls from east to west, the condensed steam in the east division of pipes returns into the boiler ; but as on the west it cannot do so, pieces of pipe $\frac{5}{8}$ ths inch bore, and 4 inches in length, are cast on the under side of the steam-pipe at *h h h*, in the west division. The condensed steam passes through these pipes into the cisterns, and flows over into the gutter, as does also the condensed steam from the chamber, and is carried off by the small drains *ii*.

k k, Cast-iron rollers in frames, on which the pipes rest, the under part of the pipes being $2\frac{1}{2}$ inches above the brick seat.

ll, Figs. 1. and 2. Plate XIV, Slide valves or cocks, by which the steam is admitted at pleasure into the pipes of the melon pit. The draw-rod passes through an oblong opening in the cover *m*, which is of polished Arbroath pavement, and the opening is covered over with an oblong piece of brass about $\frac{5}{8}$ ths inch thick, secured

to the stones by bats and screws. This piece of brass has also an oblong opening, through which the rod of the valve passes to the outside of the plant-pit, and is of such length as to allow for the elongation of the iron-pipes when heating, and their contraction in becoming cold. On the surface of this piece of brass is placed another, furnished with a stuffing box, through which the rod passes and keeps it in its place. Both are fitted close to each other, and kept down by a leaden weight, and thus the escape of steam from the chamber below into the atmosphere of the pit is prevented. After this simple apparatus has been adjusted, the cross handle of the rod is fixed on with a screwed nut*.

n A stuffing box made of two pieces of sandstone batted together, with a circular cast-iron cover bolted to the stones; the box is stuffed with lint and a little tallow to prevent the heat and steam from passing from the one pit into the other. The pipes being laid, small brick pillars *oo* are built on each side about 5 inches higher than the upper side of the steam pipe. These pillars support pieces of rough flags *p* in the section, crossing the pipes with openings left between each piece. The pillars must be so placed that they shall not intercept the steam issuing from the blow holes. This cover pre-

* This valve is not conveniently placed. Had it been at first required to have pits for the culture both of the pine-apple and melon, I would have placed the pine-pits where they now stand, with some difference in their construction more suitable for the culture of the pine-apple; and I would have placed the melon-pits on the right and left of the furnace house, as at *PP* in the ground plan, and at *Q* in the section. All the valves, in this case, would have been in the inside of the furnace house.

vents any pressure of the stones upon the pipes. Were this not attended to, the repeated motion of the pipes among the stones, in expanding or contracting, would soon shake or rend the whole building. The three first layers of stones at the bottom of the steam-chamber are $4\frac{1}{2}$ to 4 inches in diameter; they are then gradually reduced from 4 to $3\frac{1}{2}$, 3 to $2\frac{1}{2}$, and 2 inches; the layers near the top are about the size of hen's eggs, those above about the size of pigeon's eggs, and the levelling rows at the top that of large marbles*.

The covers *r* of the steam-chamber are of Arbroath pavement, $2\frac{1}{2}$ inches thick, half checked on each other, and laid down so as to rest upon the top of the pillars *cc*, pressing gently on the small stones below, and closely jointed with Roman cement. Where proper flags cannot be procured, some of these pits have been covered with checked bricks made of fire-clay, 18 by 9 inches, and laid on cast-iron rafters.

The covers of the steam-flues *RR* are laid in the same manner, they are $2\frac{1}{2}$ inches thick, and let into the sides of the flues with a half-inch check.

- ss.* Cast-iron steam tubes with lifting covers, the tubes are $2\frac{1}{2}$ inches diameter by the same in height. On the bottom of the tubes, a square piece is cast, which is sunk into the top of the cover of the steam-flue, and fixed with lead. By lifting the covers of the tubes, the steam, which is greatly modified before it reaches them, will emit a moist heat to the plants, and even

* Some of these pits, and plant and pine-stoves, have been filled with stones picked from the beds of rivers, some with stones gathered from the sea-beach, some with stones taken from the ground and washed clean: and others with whin-stone broken to the proper sizes.

raise the temperature ; and, by replacing the covers, the heat will be immediately withdrawn.

S Represents about 4 inches of furnace ashes.

tt. A movable piece of wood to raise the bed of earth for the plants near the glass, if required.

T, Boiler with gauge cocks and safety valves, &c.

uu, The alarm pipe dipping in the boiler a little below the lowest guage-cock. Should any accident prevent the regular supply of the boiler with water, as soon as it has evaporated to this level, the steam rushes up the pipe, producing a loud whistling noise, and giving notice to the gardener, that his attendance is required to the boiler.

U, Feeding cistern with hydrostatic balance and valves.

I may mention here, that steam at a moderate pressure of from 1 to 2 pounds per square inch, is, in my opinion, better adapted for the purposes intended by these pits than steam at a higher pressure.

V, Cistern and ball-cock for supplying the boiler, having a waste-pipe, about $\frac{5}{4}$ th inch higher than the water stands in the boiler, with a cock which drains both the cistern and the boiler, when it is necessary to clean them. It was first designed to supply the boiler of the steam-pits at Cunnoquhie, by a feeding apparatus ; but it was afterwards thought that the gardener would manage it with more ease, if it were supplied with water from a small cistern connected with it on the same level, and the cistern fed by a properly constructed cock and half globular ball, the steam being thus blown upon the stones in the steam-chamber at the atmospheric pressure.

ll, on the ground plan, Slide valves or cocks. The case of the valve is of cast-iron, with a brass slide fitted into

the inside, and a stuffing box, and cross headed handles. These valves admit the steam into either of the pipes at pleasure, or into both at the same time; and when this is the case, that there may be a sufficient supply of steam for both, the bore of the pipe X is made 4 inches.

The furnace being finished, and the pipes laid, the passages for the pipes into the pits WW, are firmly stuffed with dried moss, and two pieces of stone are prepared to fit the circumference of the pipes, leaving no more than room for their expansion. These being put in, the openings left for introducing the pipes are built up.

The section of that part of the pits to be used for the culture of pine-apples is 10 inches higher, both on the south and north, than that for melons. The glass-roof consists of two sashes, with a ridge-tree between them $1\frac{3}{4}$ inch thick, to which the rafters are fixed, and the upper ends of the sash-stiles hinged. The hinge crosses the top of the ridge at the height of the sash, having a joint on each side with moveable pins; the middle part is screwed to the ridge, and the tails to the middle of the sash-stiles, before the cope or upper part of the ridge-tree is fixed on. The front or south sash is made more than double the length of the north one, that the influence of the sun's rays may reach the back of the plant-pit. The sashes are 3 feet 2 inches broad.

The rafters are $1\frac{1}{2}$ inch thick between the sashes, and continue at this thickness for fully $\frac{1}{4}$ th inch above the stiles of the sashes. They are then reduced on both sides $\frac{5}{8}$ ths of an inch, the remainder being $\frac{6}{8}$ ths inch thick, and $1\frac{1}{4}$ th inch high, with a cope on the

top of it, which is mitred into the cope of the ridge-tree. This forms a place for receiving wooden-shutters to cover the glass at night in winter. To the under part of the rafters, at the height of the wall-plates (which are 2 by $4\frac{1}{2}$ inches), are nailed pieces of deal $1\frac{1}{8}$ th inch thick, and broader than the rafters by 1 inch on each side. At the bottom these are checked into the wall plates; and, together with the wall-plates, form the rest for the under side of the sashes. On each side of the rafters, near the bottom, and to the edge of the sash-rest, an iron-stay is screwed, having a hook at the upper end, and moving on the screw-nail with which it is fixed. An iron eye is screwed into the edge of the rest for the hook to enter. On the under side of each sash-stile other eyes are screwed, and so placed that, when the sashes are opened, and the end hooks of the stays placed in them, the gardener may have head-room to do any work in the pits. All the sashes at the bottom are furnished with iron-handles. Air is given by tilts in the common way.

It will be found that there is a sufficient degree of bottom heat in the plant-pits, either for the culture of *Ananas* or Melons, and other plants, the flags at the bottom *r*, and the sides *e e* of the plant-pits being all in contact with a mass of heated matter, which is excluded from the action of the external air. It will also be seen that there is a sufficient degree of heat for the atmosphere of the pits. Take, for instance, the end division or melon-pit: the depth of the steam-chamber is 3 feet, the plant-pit is 1 foot 8 inches, and the breadth of the cover of the flue is 1 foot 2 inches, making together 5 feet 10 inches; the length of the chamber-wall on both sides is 9 feet

6 inches, together equal to 19 feet. This multiplied by 5 feet 10 inches, gives 111 superficial feet nearly. The end of the chamber-wall is 8 feet 4 inches, which, multiplied by 3 feet, the depth of the chamber, gives 25 feet; both together making nearly 136 square feet of surface in close contact with a mass of stones heated to about 170° . But should this be found to give out too little heat, a considerable increase may be obtained by making the steam-flue return on each end of the pits as some of them have been built; or, if a drier and greater degree of heat be required than that given out by the brick-wall of the chamber, this may be easily accomplished by constructing the chamber-wall either of Arbroath pavement, or the kind found in the neighbourhood of Dundee, which is still better adapted for the purpose, as it is not only very hard and impervious to moisture, but may be got of any suitable dimensions. In constructing the chamber of these materials, two flags, of 4 feet 10 inches long, and $3\frac{1}{2}$ inches thick, may be set up on end, the height of the chamber and flue, and two others of any length, laid horizontally between them, and so on till the chamber is completed. They will require no other work than to be properly *joggled* into one another, and jointed with Roman cement. This will give out more heat and less moisture than the brick-walls, but will not retain the heat so long. The open space *a a*, round the pits, must be kept clear of rubbish, which may be done by the covers of the steam-flue being made broad enough to cover it, and neat oblong cast-iron lifting ventilators, *in frames*, 10 inches long and $2\frac{1}{4}$ inches broad, inserted at every foot distance, into the cover of the flue above the open space. In this man-

ner, the heat from the sides of the chamber may then be given or withheld at pleasure*.

It is of importance, in the management of steam-pits, to have a thermometer so constructed as to render it easy to ascertain the temperature at the bottom of the earth, or pots, in the plant-pit. An instrument adapted for this purpose is represented in Plate XIV. Fig. 3., the ball and stem are protected by a brass case, the upper part of which is composed of two tubes, cut open wide enough to shew the scale; the outer one turns round by the hand, and incloses the scale, to protect it when the plants are watered with the syringe.

By comparing the length of the pits at Cunnoquhie with those at Castle Semple, it will be seen from Mr Smith's communication to the Society, and from Mr Lauder's report to me, noticed above, that, at the former place, 30 feet of pits, in two divisions, take 3 hours of steam *in every 24 hours* to raise the temperature to the height required; but, at the latter place, above 60 feet of pits, nearly 1 foot broader, take only 3 hours of steam in every 48, although, at both places, the steam from the boiler is admitted into the steam-chamber at the same pressure. The reason of this difference is, that the pits at Cunnoquhie have only 2 feet depth of stones, while those at Castle Semple have 3 feet.

The nearer that these pits are built upon a level, the more nearly will the heat be equalised both in their chambers and atmospheres.

* A house of considerable dimensions, properly constructed, will be found to require very little more heat, if any, to keep it at a proper temperature than that given out by the steam-chamber wall.

THE General Meeting, held on the 5th March 1829, having heard a communication from Mr JOHN HAY, Plan-ner, relative to the application of steam in a close chamber, filled with rounded stones, for affording bottom heat in pine-apple and melon pits, and having examined plans furnished by him, unanimously agreed in awarding to Mr HAY the London Medal for 1828.

P. N. *Sec.*

(601)

INDEX.



INDEX.

	Page
A	
ACCLIMATATION of plants, hints on the,	313
Address voted to the King, on occasion of his Majesty's visit to Edinburgh,	43
Æcidium laceratum infecting a hawthorn hedge,	459
Anbury disease in turnips, account of the,	529
Apples, on the keeping of,	326
—— account of a select collection from Dysart House,	331
—— list of, cultivated in a Carse of Gowrie orchard,	470
Apricot-tree, advantages of budding the peach upon,	367
Ash, white American, notice regarding the,	251
Asparagus, on renovating plantations of,	478
B	
Balcarras Orchard, account of,	292
Ballindean, plan of the arrangement of fruit-trees in the gar- den at,	168
Bark, old, of fruit-trees, on removing the,	220
Beattie, Mr William, on destroying the scaly insect,	209
Bisset, Mr Alexander, on the use of grass-sward for forward- ing early crops of peas, &c.	180
Black walls in gardens, on the advantage of,	258
Blaikie, Mr Thomas, on the locust-tree, &c.	212
Blair, Mr Thomas, on the hardy fruits of Upper Canada,	254
—— Mr William, on the cause of canker, &c.	358
Blight, notice regarding the,	249

Blossom of wall-trees, account of Mr Smith's screens for protecting,	342
————— Mr Dick's frame for protecting,	400
————— Mr Irving's screens of net-work and ferns,	450
Boiling-hot water used for destroying insects on wall-trees,	210
Borders, fruit-tree, on the mulching and watering of	244
Brandy, home-made, manufacture of,	487
Broccoli, Sicilian, on the culture of,	419

C

Camellia, account of a new mode of grafting the,	133
Campbell, Mr Peter, on preparing soil for carrots and onions,	333
————— on canker in fruit-trees,	559
Canada, Upper, notices regarding the hardy fruits of,	254
Canker, on preventing, by shallow planting,	292—304
————— on the cause of, in fruit-trees, by Mr Blair,	358
————— on the nature of, by Colonel Spens,	429
————— depending on bad subsoil, notice regarding,	559
Carrots, on the proper soil for,	333
————— on preparing ground for,	393
Carse of Gowrie orchard fruits,	470
Carta erigens Societatem in corpus corporatum et politicum,	94—100
Cartwright, Mr Edmond, on the forcing of sea-cale, &c.	419
Cassi liqueur, mode of making,	489
Caterpillar, gooseberry, on destroying by means of heat,	378
————— on destroying by means of quicklime,	394
————— on destroying,	421
————— fruit-tree, on destroying,	526
Celtis australis, notice regarding the,	218
Charter of the Society, warrant for,	87—93
Cheese-gourd, receipt for dressing,	324
Cider, Scottish, medal awarded for,	57
Circular training of grape vines,	236

Citrus, genus, fine specimens of the, from Woodhall,	37
Climate, insular, on the uniformity of,	370
Coal-tar used for painting garden-walls black,	260
Coppice-woods, on the management of,	194
Corsican pine, notice regarding the,	252
Coul, seedling apples raised at, by Sir G. S. Mackenzie, 85, 554	
Creelman, Mr William, account of his garden with inclined walls,	493
Creme de Rose Liqueur, mode of making,	488
——— de Moka, mode of making,	489
Crichton, Mr Daniel, on edible gourds,	323
————— on the Ionian and the Malta melons,	354
Cucumber, Russian, mode of pickling,	497
Cunnoquhie pine-pits described,	570
Curl in Potato, remarks on,	462
Cuttings, on propagating plants by means of,	312
Cydonia japonica, on the upright training of,	340

D

Desaurty, Mr Victor, on dressing gourds for the table,	324
Dewar, Mr Peter, account of steam-pits for the culture of melons,	350
Dick, Mr John, on the economical arrangement of fruit-trees in a garden,	163
————— on the upright training of rose-bushes, &c.	337
————— account of an improved garden hammer,	398
————— account of a frame for protecting blossom and fruit of wall-trees,	400
Dickson, Mr A., Treasurer to the Society, piece of plate voted to him for his important services,	49
Don, Mr William, notice of a hawthorn hedge affected by a parasitical plant,	459
Dunbar, Professor, on grafting camellias,	133
Duncan, Dr Andrew, <i>senior</i> , observations on the culture of onions,	305

E

Elm, Siberian, notice regarding the,	253
Experimental Garden, circular letter regarding the, -	101

F

Fingers and toes, disease in turnips so called, account of,	529
Flower-pot, description and sketch of an improved, . . .	317
Flued walls, on the cultivation of peaches, &c. against,	446
Forest-trees, on the supposed advantages of sowing instead of planting,	205
———— notice of some which deserve the attention of Scottish cultivators,	251
Frame for saving wall-fruit, account of a,	400
Frames, oiled paper, for protecting blossom,	342
Fruit-trees, economical arrangement of, in a small garden,	163
———— on the training of,	267
———— on scraping off the old bark of,	220
———— borders, on the mulching and watering of,	244
———— on canker in,	559
Fruits, hardy, of Upper Canada, notice of the,	254
—— on the preservation of,	374
—— used for making domestic wines,	375
Fruit-room, notice of a,	327
—— frame for protecting from wasps, &c.	400

G

Gardens near Edinburgh, visitation of, by a Committee of the Society,	28
Garden, Experimental, letter from the Society to the Hon. Barons of Exchequer, requesting them to purchase ground,	52
———— various documents regarding,	101—130
———— plan and description of,	118

Garden Committee, first report of the,	109—121
———— second report of the,	122—130
Gardener's Library, on the formation of a,	441
Germination of seeds, remarks on the,	564
Glazing hot-houses, notice of an improved method of,	348
Gooseberry caterpillar, on the natural history of, &c.	378
———— bushes, list of the best kinds,	481
———— wine, mode of making,	487
———— seedling, called Rob Roy, account of,	557
Gordon, Mr John, account of the implement called Scarifi- cator,	395
Gorrie, Mr Archibald, on destroying slugs,	289
Gourdiehill Orchard, account of fruits cultivated in,	467—477
Gourds, edible, account of, and of the mode of dressing,	322
———— various modes of dressing,	505
Gowrie, Carse of, orchard-fruits cultivated in the,	470, &c.
Grape-vines, shy setters dusted with the pollen of free setters,	85
———— trained on the outside of the sashes of a plant stove,	520
———— account of a method of cultivating at Bella- drum,	234—243
———— on the management of, in peach-houses,	455
———— on the kinds best suited for flued-walls in Scotland,	500

H

Hammer, notice of an improved one for nailing-in wall-trees,	398
Hawthorn-hedges, notice of a disease affecting,	459
Hay, Mr John, inventor of method of heating, by introducing steam into a chamber filled with loose stones,	583
———— London Medal for 1828, awarded to him,	600
Heat, applied for the destruction of the gooseberry caterpillar,	378
Hedge-row trees, notices regarding,	198

Henderson, Mr John, Brechin, on improving garden-walls, &c.	258—272
Henderson, Mr Alexander, on saving of seeds in Scotland,	416
History of the Society from June 1819, to Oct. 1826,	21—86
Holly, Chinese, notice regarding the,	252
Hop-tops used as a substitute for asparagus,	504
Hopetoun House Garden, mulching of fruit-tree borders at,	244
Horticulture, hints and notices connected with, by Mr John Murray,	370, &c.
Hosie, Mr Robert, on the management of oak coppice woods,	189—199
Hot-houses, improved mode of ventilating,	200
Hot-walls, on the grape-vines best suited for, in Scotland,	500
Hot-houses, on heating by means of steam,	511
————— planned for peach-trees and grape-vines,	577
Howison, Mr James, on ripening fruit by artificial heat,	279
————— account of an improved flower-pot,	317
Howison, Dr William, on the Russian cucumber, &c.	497

I

India, list of subscribers to the Experimental Garden from,	104
Indian saws, notice regarding,	362
Insects on fruit-trees, destroyed by means of boiling hot wa- ter,	210
Insular climate, on the uniformity of,	370
Ionian melon, notice regarding the,	354
Irving, Mr William, on the cultivation of peaches, &c. on flued walls,	446—454

J

Jenyns, Rev. George, on anbury in turnips,	547
--	-----

K

Kelly, Mr A. on raising mushrooms during winter,	283
Key, Mr Alexander, gardener at Barskimming, honorary medal awarded to him,	48

King, The, becomes Patron of the Society,	31
Kirschenwasser, imitation of,	84
———— mode of making,	489
Kyle, Mr John, at Blair Drummond, honorary medal award- ed to him, December 1820,	35

L

Lactucarium, premium awarded for manufacturing,	34
Library, gardener's, on the formation of a,	441
Liqueurs, account of the mode of making various,	486
Livingston, Mr R. F. D. account of a hot-house for peach- trees and grape-vines,	576
Locust-tree of Cobbet, remarks on the,	212
London Medal for 1826, awarded to Mr John Henderson,	258
———— for 1827, to Mr Archibald Reid,	292
———— for 1828, to Mr John Hay,	600
Lowe, Mr Peter, on the curl in potatoes, &c.	462

M

Macdonald, Mr James, on training grape-vines on the out- side of the sashes of a plant-stove,	520
Macdougall, Messrs, on the anbury of turnips,	544
Machray, Mr John, on grafting of orange-trees, &c.,	310—316
———— on destroying caterpillars,	526
Mackenzie, Sir G. S. notice of seedling apples raised by him,	85
———— farther account of,	554
Malta Melon, notice regarding the,	356
Macmurtrie; Mr W., on the artificial ripening of immature tomatoes,	364
———— on the advantages of budding the peach upon the apricot,	367
Marrow, vegetable, receipt for dressing,	324
Martin, Mr John, on grape-vines,	455
Matthew, Mr Patrick, account of Gourdiehill Orchard,	467

Meason, Gilbert Laing, Esq. on some forest and ornamental trees, deserving the attention of Scottish cultivators,	251
Melons, Ionian and Malta, notices regarding,	354
——— account of steam-pits for the culture of,	350
——— description of the pit at Cunnoquhie,	571
Members of the Society, List of, elected from 4th March 1819 to 7th September 1826,	3—14
Mice, on saving peas and beans from the attacks of,	452
Middleton, Mr John, on the cultivation of strawberries,	400
Mildew, notice regarding the,	249
Mitchell, Mr John, gardener at Moncrieffe House, honorary medal voted to,	67
Moffat, Mr James, gardener at Ayton, honorary medal awarded to him, December 1819,	27
Moss or hypnum, cultivation of plants in,	158
Murray, Mr John, hints and notices connected with horticulture,	370—377
——— ——— on germination and vegetation,	564
Mushrooms, on the raising of,	273
——— on raising, during winter,	283

N

Naturalization of exotic plants at Biel,	22, 60
Nectarine, seedling, from Woodhall,	30
Nectarines, on the cultivation of, against flued walls,	446
Neill, Mr. P., Secretary, piece of plate voted to him during his absence abroad,	39
Niven, Mr Ninian, on the cultivation of the grape-vine,	234
Nonpareille liqueur, mode of making,	490

O

Oak coppice-woods, on the management of,	189
Office-bearers of the Society 1826,	20
Oliver, Mr William, on the keeping of apples,	326
Onions, observations on the culture of, by Dr Duncan <i>sen.</i> ,	305

Onions, on preparing a soil for,	336
—— on the cultivation of,	391
—— on the transplanting of, by Colonel Spens,	425
—— on the transplanting of, by Mr Lowe,	466
Orange-trees, on the grafting of,	314
Orchard fruits, list of, in the Carse of Gowrie,	470

P

Paper birch-tree, notice regarding the,	251
Paterson, Colonel George, account of steam-pits at Cunnockuhie,	570
Peach tree, account of the French methods of cultivating the,	138
Montreuil method,	145
A la Dumoutier,	147
A la Sieulle,	152
—— on budding of, on the apricot-tree,	367
—— on the cultivation of, against flued walls,	446
Peach-house planned also for grape-vines,	577
Pears, Scottish, notice of,	437
—— orchard, list of some Scottish,	475
Peas, early, forwarded by sowing on grass-sward,	181
Pederana, M. Lewis, on making liqueurs,	486—491
—— ——— on dressing gourds for the table, 505—510	
Perth Nurseries, account of an inclosed collection of gooseberry bushes in,	481
Pine-apples, culture of, in steam-pits at Cunnockuhie,	572
Pinus Laricio, notice regarding the,	252
Pit, economical, for preserving vegetables during winter, &c.,	173
— for grape-vines, described and figured,	238
Platanus occidentalis, notice regarding,	218
Plums, seedling, raised at Coull, account of,	557
Portobello, account of inclined walls in a garden at,	493
Potatoes, early, means of forwarding,	184
Potiron gourd, mode of dressing for table,	505

Q

Quicklime used for destroying gooseberry caterpillar, 394

R

Ranunculuses, seedling, on the raising of, 227
 Red Spider, on the natural history of the, 360
 Reid, Mr William, gardener at Gilmerton, honorary medal
 awarded to, 48
 ——— Mr Archibald, on preventing canker, &c. 292
 Rhodes, Rev. James Armitage, on heating hot-houses by
 steam, 511—519
 Rhubarb-stalks, on the forcing of, 273
 Robertson, Mr Daniel, on renovating asparagus beds, 478
 Robinia pseudacacia, notices regarding the, 213
 ——— spectabilis noticed, 215
 ——— viscosa and hybrida, noticed, 217
 Robison, John, Esq., account of an improved mode of glaz-
 ing hot-house sashes, 348
 ——— ——— ——— notice of Indian saws, 362
 Rose-bush, on the upright training of, 337

S

Saws, Indian, notice regarding, 362
 Scaly insect, on a method of destroying the, 209
 Scarificator, figure and description of the, 395
 Sea-cale, on the forcing of, 418
 Seeds, on the saving of, in Scotland, 416
 Seedling fruits, notice of several, 83
 Shareholders in the Experimental Garden, list of original, 105
 Shiells, Mr George, on grape-vines best suited for hot-walls
 in Scotland, 500
 Sinclair, Right Hon. Sir John, on Anbury in turnips, 550
 Sinclair, Mr George, on the Anbury of turnips, 531

Sloping of subdivision walls in gardens recommended,	265
Slugs, on destroying,	289
Smith, Mr James, on the mulching and watering of fruit-tree borders,	244—250
— on the formation of a gardener's library,	441
— Mr John, on the French method of cultivating the peach-tree,	138—157
— Mr Alexander, account of screens for protecting wall-trees,	342—347
Soup of gourds, recipe for making,	324
Sowing, instead of planting, of forest-trees, on the supposed advantages of,	205
Spens, Colonel, on canker in fruit-trees, and on Scottish pears,	425—440
Spider, red, natural history of the	358
Spurs of wall fruit-trees, on the importance of nailing them close to the wall,	268
Steam, on heating hot-houses by means of,	511
Steam-pits for the culture of melons, account of,	350
— at Cunnoquhie described,	570
— minute description of, by Mr Hay,	591
Stewart, Mr Alexander, account of pit for raising early vegetables, &c,	173
Still for the manufacture of liquors, plan and section of,	492
Strawberries, forcing of, means of facilitating,	186
— on the cultivation of,	408
Street, Mr John, on cultivating plants in hypnum-mosses,	158
Stuart, Mr James, on forcing rhubarb-stalks in the open air,	273
Subdivision walls in gardens, improvements on,	263
Sward-turf, use of, for forwarding early crops of peas,	78, 180

T

Thom, Mr Robert, on the gooseberry-caterpillar,	378
Thomson, Mr Thomas, on scraping off the old bark of fruit-trees,	220, &c.

Tomatoes, immature, on the artificial ripening of,	364
Top-dressings, on the utility of, in garden crops,	479
Transplanting of onions recommended,	307
Turf-grass, used for forwarding early crops of peas, potatoes, &c.	180
Turnip, early white, on the saving the seed of,	416
Turnips, on the disease called Anbury in,	529—553
Turnbull, Mr Archibald, list of select gooseberries, cultivated by,	481
Tweedie, Mr John, account of a mode of ventilating hot-houses,	200

V

Valleyfield, account of economical pit for preserving vegetables at,	173
Vegetables, on preserving, through the winter,	498
Vegetable marrow, receipt for dressing,	324
Vegetation of seeds, notes on the,	564
Ventilating of hot-houses, improved mode of,	200
Vine-pit described and figured,	238
Vines, grape, on propagating by layers and cuttings,	457

W

Wall, garden, general hints for improving a,	258
— subdivision, should be inclined to the horizon,	265
— account of an inclined, at Portobello,	493
— trees, account of Mr Smith's oiled paper-screens for protecting the blossoms of,	342
— Mr Irving's screens of net-work and fern,	446
— trees, advantages and disadvantages of,	376
— fruit, frame for preserving,	400
— flued, on the grape-vines best suited for,	500
Wallace, Mr John, on the cultivation of onions and carrots,	391
Walnut, white, notice regarding the,	253

Warrant for royal charter,	87
Water in a boiling hot state applied to fruit-trees, for destroy- ing insects,	210
Water, hot, applied for the destruction of gooseberry-cater- pillar,	389
Waterston, Mr John, on the raising of seedling ranunculuses,	227
Wines, home-made, report regarding,	61, 72
Witherspoon, Mr Alexander, on destroying caterpillars,	421

Y

Young, Mr Arthur, on the anbury of turnips,	542
---	-----

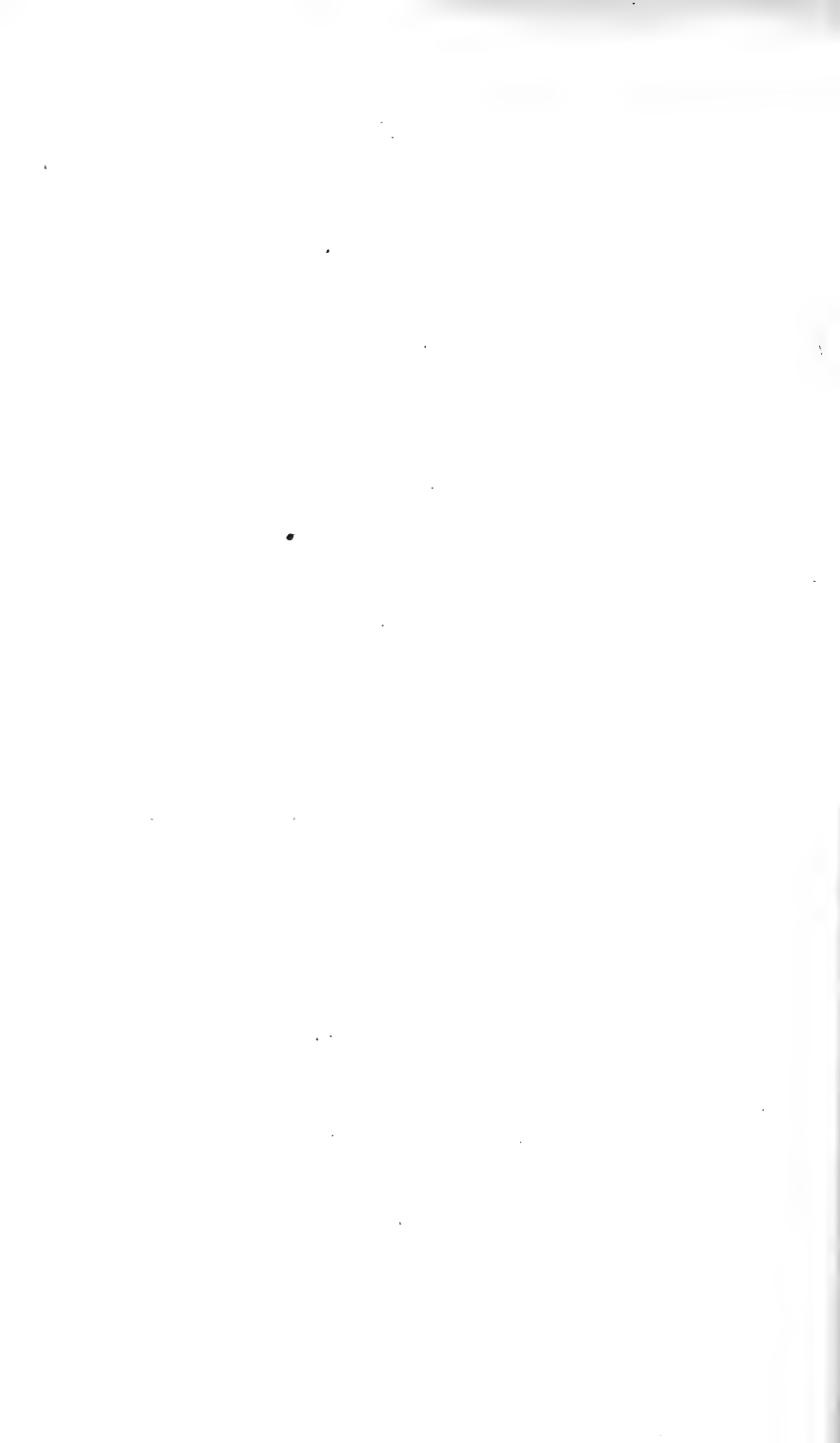

LIST OF PLATES IN VOL. IV.

IN PART I.

	Page
PLATE I. Plan of the Experimental Garden, Inverleith,	118
II. Professor DUNBAR'S New Mode of Grafting Camellias, - - -	136
III. Mr ALEXANDER STEWART'S Economical Vegetable Pit, - - -	173
IV. Illustrative of Mr HOSIE'S Plan of Thinning Oak Woods, - - -	190
V. Mr NIVEN'S Grape-Vine Pits, . - -	243

IN PART II.

VI. Mr ROBERTSON'S Improved Mode of Glazing Sashes, - - -	348
VII. Mr DEWAR'S Steam-Pits, - - -	353
VIII. Indian Saws; Apparatus for applying Hot-Water to Gooseberry-bushes, &c. - - -	362
IX. Mr DICK'S Preservative Frame, - - -	406
X. Mr CREELMAN'S Inclined Fruit-walls at Portobello, - - -	496
XI. Reverend Mr RHODES' plan of Heating Hot-Houses by Steam, - - -	519
XII. XIII. Mr MACDONALD'S Mode of Training Grapevines on the outside of Hot-House sashes, - - -	525
XIV. XV. Mr HAY'S Pine-apple Pit, heated by means of Steam introduced into a close chamber filled with rounded stones, - - -	591

