



MEMOIRS AND PROCEEDINGS
OF THE
MANCHESTER
LITERARY & PHILOSOPHICAL
SOCIETY.

(*MANCHESTER MEMOIRS.*)

VOLUME LIX. (1914-15.)

MANCHESTER:
36, GEORGE STREET.
1916.

235522

LIBRARY
UNIVERSITY OF CALIFORNIA
BERKELEY

NOTE.

The authors of the several papers contained in this volume are themselves accountable for all the statements and reasonings which they have offered. In these particulars the Society must not be considered as in any way responsible.

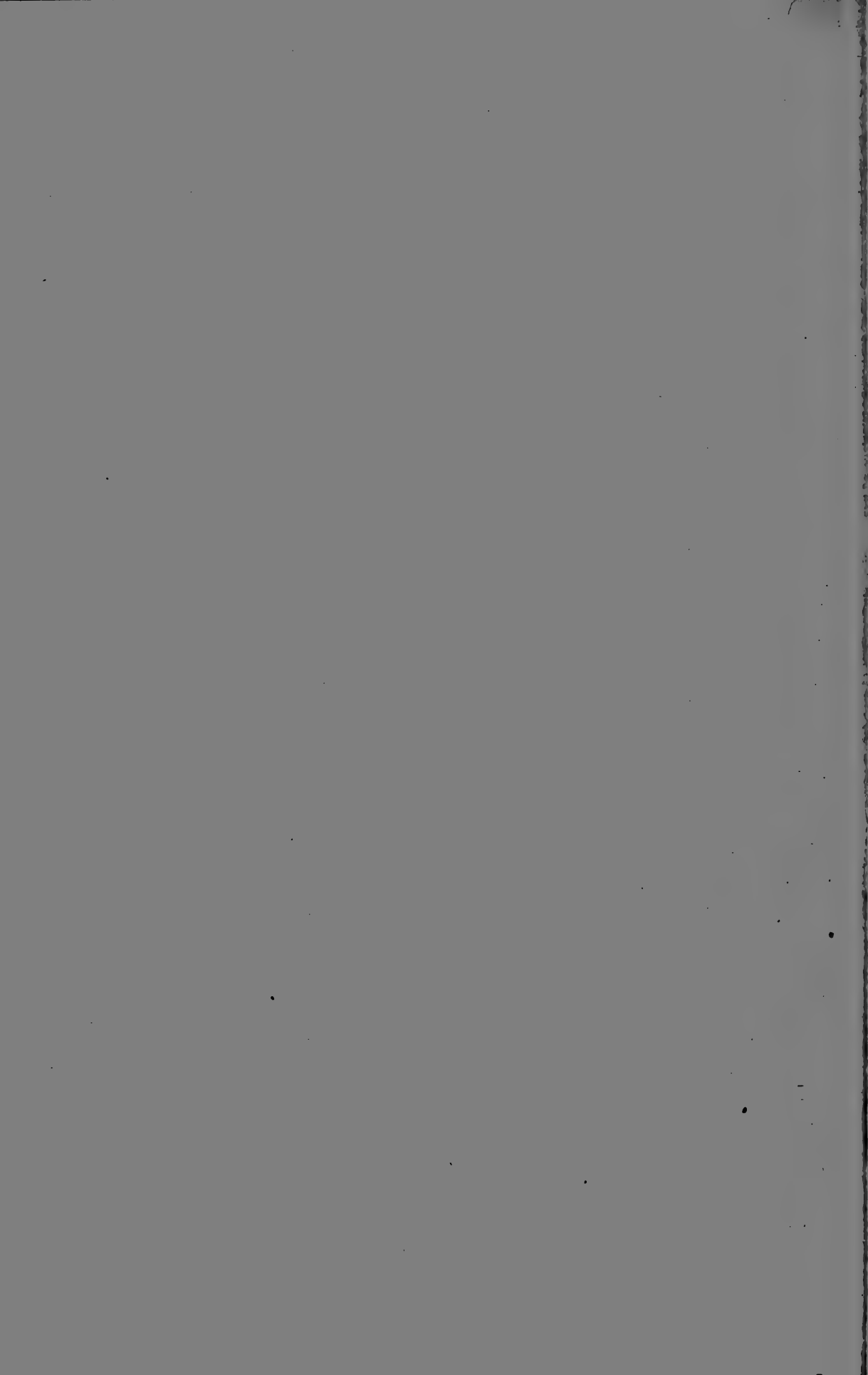

CONTENTS.

MEMOIRS.

- I. The Pennatulaceae of the Cape of Good Hope and Natal. By
J. STUART THOMSON, Ph.D., F.L.S., F.R.S.E. *With*
2 Plates. pp. 1—26
(Issued separately, January 19th, 1915.)
- II. Graphical Determination of the Stresses in the Main Spars of
Monoplanes. By CECIL H. LANDER, M.Sc., A.M.Inst.
C.E. *With 9 Figs.* pp. 1—15
(Issued separately, January 20th, 1915.)
- III. Studies in the Morphology of *Isoëtes*. I. The General Mor-
phology of the Stock of *Isoëtes lacustris*. By Professor
WILLIAM H. LANG, M.B., D.Sc., F.R.S. *With 6 Text-figs.*
(Issued separately, February 6th, 1915.) pp. 1—28
- IV. Variation in a Carboniferous Brachiopod—*Reticularia lineata*
(Martin). By HENRY DAY, B.Sc. *With 1 Pl. and 7*
Text-figs. pp. 1—18
(Issued separately, February 11th, 1915.)
- V. Note on Foggy Days in Manchester. By WILLIAM C.
JENKINS, F.R.A.S. *With 1 Text-fig.* pp. 1—4
(Issued separately, March 9th, 1915.)
- VI. Note on the Monthly Variation of Sunshine. By Professor
W. W. HALDANE GEE, B.Sc., M.Sc.Tech. *With 5 Text-*
figs. pp. 1—4
(Issued separately, March 15th, 1915.)

- VII. A Note on the Behaviour of a Blackbird—a Problem in Mental Development. By T. A. COWARD, F.Z.S., F.E.S. pp. 1—8
(*Issued separately, April 30th, 1915.*)
- VIII. Studies in the Morphology of *Isoëtes*. II. The Analysis of the Stele of the Shoot of *Isoëtes lacustris* in the light of Mature Structure and Apical Development. By Professor W. H. LANG, M.B., D.Sc., F.R.S. *With 4 Pls. and 1 Text-fig.* pp. 29—56
(*Pages and illustrations are numbered to follow Part I. of this series.*)
(*Issued separately, May 31st, 1915.*)
- IX. On two cases of Parallelism in the Aphidæ. By A. W. RYMER ROBERTS, M.A. *With 1 Pl. and 4 Text-figs.* ... pp. 1—12
(*Issued separately, June 7th, 1915.*)
- X. On the Significance of the Geographical Distribution of the Practice of Mummification—A Study of the Migrations of Peoples and the Spread of certain Customs and Beliefs. By Professor G. ELLIOT SMITH, M.A., M.D., F.R.S. *With 2 Maps* pp. 1—143
(*Issued separately, July 7th, 1915.*)
- XI. The Place of Science in History. By Professor JULIUS MAC LEOD, D.Sc. pp. 1—45
(*Special Lecture, May 4th, 1915.*)
(*Issued separately, August 31st, 1915.*)
- XII. John Dalton's Lectures and Lecture Illustrations. Parts I. and II. By Professor W. W. HALDANE GEE, B.Sc. M.Sc.Tech. Part III. By HUBERT FRANK COWARD, D.Sc., and ARTHUR HARDEN, D.Sc., Ph.D., F.R.S. *With 8 Pls.* pp. 1—66
(*Issued separately, September 3rd, 1915.*)
- XIII. Trisecting an Angle. By Professor W. W. HALDANE GEE, B.Sc., M.Sc.Tech., and ARTHUR ADAMSON, M.Sc.Tech., A.R.C.S. *With 1 Pl. and 24 Text-figs.* pp. 1—35
(*Issued separately, October 7th, 1915.*)

INDEX.

M=Memoirs. P=Proceedings.

- Accessions to Library. P. i., iv., vi., x., xi., xii. xiii., xv., xvii., xix.,
xxi., xxiv.
- Accounts. P. xlvi.
- Adamson, A. On Projection Screen invented by Thomas Thorp. P. xvi.
— and W. W. Haldane Gee. Trisecting an Angle. M. 13.
- Aerolite from Standish, Exhibition of, by W. C. Jenkins. P. vi. Note on.
P. xi.
- Aerolite which fell at Standish. Note by Henry Wilde. P. vii.
- Amagat, E. H. Obituary notice of. By C. L. B. P. xxix.
- Annual General Meeting. P. xxi.
- Annual Report. P. xxv.
- Atack, F. W. The Salt-formation of Oximes. P. ix.
- Auditors. P. xiv.
- Autunite, Exhibition of fine crystals of. By *Sir* Ernest Rutherford. P. xvii.
- B. Obituary Notice of Nathaniel Bradley. P. xxx.
- Barnes, C. L. Exhibition of Japanese "Magic" Mirror. P. v.
— Obituary notice of E. H. Amagat. P. xxix.
- Bradley, N. Reference to the death of. P. xv.
— Obituary notice of. By B. P. xxx.
- British Association, Meeting of. P. xxii.
- Broadhurst, Mrs. E. Tootal. Presentation of an engraving of Elihu
Burritt. P. v.
- Brown, T. Graham. Note on the physiology of 'walking' with especial
reference to its occurrence in the unborn foetus of the cat. P. xiv.
- Bullet wounds, Note on. By H. Ramsden. P. x.
- Burritt, Elihu, Engraving of, presented by Mrs. E. Tootal Broadhurst.
P. v.
- Coward, H. F., and Harden, A. John Dalton's Lecture and Lecture
Illustrations. Part III. M. 12. P. xxiv.
- Coward, T. A. Note on the Behaviour of a Blackbird—A Problem in
Mental Development. M. 7. P. xix.
- Dalton Diagrams. Exhibition of. By R. L. Taylor and W. W. Haldane
Gee. P. iii.

- Dalton's Lectures and Lecture Illustrations. Parts I. and II. By W. W. Haldane Gee. Part III. By H. F. Coward and A. Harden. M. 12. P. xxiv.
- Darling Downs Skull, The. By G. Elliot Smith. P. xv.
- Day, H. Some points bearing on the Relationship of the Fishes and the Amphibia. P. xx.
- Variation in a Carboniferous Brachiopod—*Reticularia lineata* (Martin). M. 4. P. viii.
- Early Presence of Certain Birds and Butterflies. By F. Nicholson. P. xix.
- Election of Officers. P. xxi.
- Election of Ordinary Members. P. iv., v., viii., ix., xvi.
- Faraday, F. J. Reference to the Death of. P. iii.
- Gee, W. W. Haldane. Exhibition of some Original Diagrams used by Dalton. P. iii.
- John Dalton's Lectures and Lecture Illustrations. Parts I. and II. M. 12. P. xxiv.
- Note on the Monthly Variation of Sunshine. M. 6. P. xiii.
- Projection Screen invented by the late Thomas Thorp. P. xv.
- See Adamson, A.
- Geikie, James. Obituary notice of. By G. H. P. xxxii.
- General Meetings. P. iv., v., viii., ix., xvi.
- Geographical Distribution of Mummification. See G. Elliot Smith.
- Graphical Determination of the Stresses in the Main Spars of Monoplanes. By C. H. Lander. M. 2. P. x.
- Harden, A. See Coward, H. F.
- Hickling, G. Obituary notice of James Geikie. P. xxxii.
- Obituary notice of Eduard Suess. P. xxxix.
- Hickson, S. J. Exhibition of "Sea Pens" from the Malay Archipelago, P. v.
- Obituary notice of. A. Weismann. P. xl.
- Isoëtes*, Studies in the Morphology of. See Lang, W. H.
- Japanese "Magic" Mirrors, Exhibition of. By C. L. Barnes and R. L. Taylor. P. v.

- Jenkins, W. C. Exhibition of Aerolite which fell at Standish. P. vi.
 — Note on Foggy Days in Manchester. M. 5. P. xiii.
 — Weather Repetitions, with suggestions for long distance forecast.
 P. xiii.
 — and Rhead, E. L. Some Notes on Aerolites. The Appley Bridge
 Aerolite of October 13th, 1914. P. xi.
- Kay, Thomas. Obituary notice of. By W. T. P. xxxiv.
 — Reference to the Death of. P. iii.
- Lander, C. H. Graphical Determination of the Stresses in the Main
 Spars of Monoplanes. M. 2. P. x.
- Lang, W. H. Studies in the Morphology of *Isoëtes*. Part I. The General
 Morphology of the Stock of *Isoëtes lacustris*. M. 3. P. x.
 Part II. The Analysis of the Stele of the Shoot of *Isoëtes lacustris*
 in the light of Mature Structure and Apical Development. M. 8.
 P. xii. Part III. The Structure and Growth of the Rhizophoric
 Region of *I. lacustris*, and the Development and Arrangement of the
 Roots. P. xxiii. The Progressive Growth of the Young Plant of
I. lacustris, and the Nature of the Cortical Extension of the Stock.
 P. xxiii.
- Lankshear, F. R. Quantitative Absorption Spectra. Part II. A New
 Ultra Violet Photometer. P. xi.
- Library Accessions. P. i., iv., vi., x., xi., xii., xiii., xv., xvii., xix., xxi.,
 xxiv.
- Longridge, R. B. Obituary notice of. By C. E. S. P. xxxvii.
 — Reference to the death of. P. iii.
- Mac Leod, J. The Place of Science in History. M. 11. P. xxiv.
- Members, Election of Ordinary. P. iv, v., viii., ix., xvi.
- Monoplane Spars. See Lander, C. H.
- Mummies from Torres Straits. By G. Elliot Smith. P. xii.
- Nicholson, F. Obituary Notice of S. B. Worthington. P. xlii.
 — On early presence of certain birds and butterflies. P. xix.
 — Reference to the death of F. J. Faraday. P. iii.
 — Reference to the death of N. Bradley. P. xv.
 — Reference to the death of Thomas Kay. P. iii.
 — Reference to the death of R. B. Longridge. P. iii.
 — Reference to the death of Thomas Thorp. P. iii.
 — Reference to the death of S. B. Worthington. P. xv.

- Note on Foggy Days in Manchester. By W. C. Jenkins. M. 5. P. xiii.
- Note on the Behaviour of a Blackbird.—A Problem in Mental Development. By T. A. Coward. M. 7. P. xix.
- Note on the Monthly Variation of Sunshine. By W. W. Haldane Gee. M. 6. P. xiii.
- Note on the physiology of 'walking' with especial reference to its occurrence in the unborn foetus of the cat. By T. Graham Brown. P. xiv.
- Obituary Notices.—E. H. Amagat, P. xxix. N. Bradley, P. xxx. James Geikie, P. xxxii. Thomas Kay, P. xxxiv. R. B. Longridge, P. xxxvii. Eduard Suess, P. xxxix. A. Weismann, P. xl. S. B. Worthington, P. xlii.
- Officers, Election of. P. xxi.
- On the Significance of the Geographical Distribution of the Practice of Mummification. By G. Elliot Smith. M. 10. P. xvi.
- On Two Cases of Parallelism in the Aphidae. By A. W. Rymer Roberts. M. 9. P. xix.
- Ordinary Meetings. P. i., iv., v., viii., x., xi., xii., xiii., xv., xix., xxi., xxiv.
- Origin of the Spectra given by Beta- and Gamma- rays of Radium. By Sir Ernest Rutherford. P. xvii.
- Oximes, The Salt-formation of. By F. W. Atack. P. ix.
- Parallelism in the Aphidae. See A. W. Rymer Roberts.
- Pennatulaceae of the Cape of Good Hope and Natal, The. By J. Stuart Thomson. M. 1. P. v.
- Place of Science in History, The. By J. Mac Leod. M. 11. P. xxiv.
- Projection Screen invented by Thomas Thorp. Exhibited by W. W. Haldane Gee. P. xv.
- Quantitative Absorption Spectra. Part II. A New Ultra Violet Photometer. By F. R. Lankshear. P. xi.
- Ramsden, Herbert. Note on bullet wounds. P. x.
- Reticularia lineata* (Martin). See Day, H.
- Rhead, E. L. See Jenkins, W. C.
- Roberts, A. W. Rymer. On Two Cases of Parallelism in the Aphidae. M. 9. P. xix.
- Rutherford, Sir Ernest. Exhibition of fine crystals of autunite. P. xvii.
- Origin of the Spectra given by Beta- and Gamma- rays of Radium. P. xvii.

- “Sea-Pens,” Exhibition of. By S. J. Hickson. P. v.
- “Sea-Pens” from the Cape of Good Hope. By J. Stuart Thomson. M. 1.
P. v.
- Smith, G. Elliot. Mummies from Torres Straits. P. xii.
- On the Significance of the Geographical Distribution of the Practice of Mummification.—A Study of the Migrations of Peoples and the Spread of certain Customs and Beliefs. M. 10. P. xvi.
- The Darling Downs Skull. P. xv.
- Société Academique de l’Aube, Communication from. P. viii.
- Some points bearing on the Relationship of the Fishes and the Amphibia.
By H. Day. P. xx.
- Special Meeting. P. xxiv.
- Stromeyer, C. E. Obituary notice of R. B. Longridge. P. xxxvii.
- Studies in the Morphology of *Isoëtes*. By W. H. Lang. Part I. M. 3.
P. x. Part II. M. 8. P. xii. Part III. P. xxii. Part IV. P. xxiii.
- Suess, E. Obituary notice of. By G. H. P. xxxix.
- Taylor, R. L. Exhibition of Japanese “Magic” Mirror made by Thomas Thorp. P. v.
- Exhibition of some Original Diagrams used by Dalton. P. iii.
- Thomson, J. Stuart. The Pennatulaceae of the Cape of Good Hope and Natal. M. 1. P. v.
- Thomson, W. Obituary notice of Thomas Kay. P. xxxiv.
- Thorp, H. On Projection Screen invented by Thomas Thorp. P. xvi.
- Thorp, Thomas. Reference to the Death of. P. iii.
- Trisecting an Angle. By W. W. Haldane Gee and A. Adamson. M. 13.
- Variation in a Carboniferous Brachiopod — *Reticularia lineata* (Martin).
By H. Day. M. 4. P. viii.
- Weather Repetitions, with suggestions for long distance forecast. By W. C. Jenkins. P. xiii.
- Weismann, A. Obituary notice of. By S. J. H. P. xl.
- Wilde, Henry. Note on Aerolite which fell at Standish on October 13th, 1914. P. vii.
- Worthington, S. B. Obituary notice of. By F. N. P. xlii.
- Reference to the death of. P. xv.

MEMOIRS AND PROCEEDINGS
 OF
 THE MANCHESTER
 LITERARY & PHILOSOPHICAL
 SOCIETY, 1914-1915

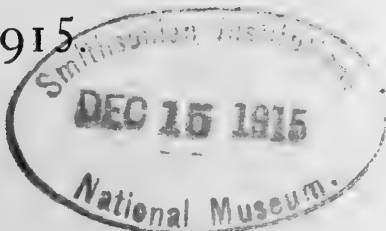

CONTENTS.

Memoirs :

- I. The Pennatulaceae of the Cape of Good Hope and Natal. By
 J. Stuart Thomson, Ph.D., F.L.S., F.R.S.E. *With 2 Pls.* pp. 1-26.
(Issued separately, January 19th, 1915.)
- II. Graphical Determination of the Stresses in the Main Spars of
 Monoplanes. By Cecil H. Lander, M.Sc., A.M.Inst.C.E.
With 9 Figures. - - - - - pp. 1-15.
(Issued separately, January 20th, 1915.)
- III. Studies in the Morphology of *Isoëtes*. I. The General Mor-
 phology of the Stock of *Isoëtes lacustris*. By Professor
 William H. Lang, M.B., D.Sc., F.R.S. *With 6 Text-figs.* pp. 1-28.
(Issued separately, February 6th, 1915.)
- IV. Variation in a Carboniferous Brachiopod—*Reticularia lineata*
 (Martin). By Henry Day, B.Sc. *With 1 Pl. and 7 Text-figs.* pp. 1-18.
(Issued separately, February 11th, 1915.)
- V. Note on Foggy Days in Manchester. By William C. Jenkins,
 F.R.A.S. *With 1 Text-fig.* - - - - - pp. 1-4.
(Issued separately, March 9th, 1915.)
- VI. Note on the Monthly Variation of Sunshine. By Professor
 W. W. Haldane Gee, B.Sc., M.Sc.Tech. *With 5 Text-figs.* pp. 1-4.
(Issued separately, March 15th, 1915.)

Proceedings - - - - - pp. i.-xvi.

MANCHESTER:
 36, GEORGE STREET.

Price Five Shillings and Sixpence.

April 30th, 1915.

RECENT ADDITIONS TO THE LIBRARY.

Presented.

- Amsterdam.**—**Société Mathématique.** Oeuvres Complètes de Thomas Jan Stieltjes. Tome I. Groningen, 1914. (*Recd. 22/ii./15.*)
- Batavia.**—**Bataviaasch Genootschap van Kunsten en Wetenschappen.** Rapporten van den Oudheidkundigen Dienst in Nederlandsch-Indië. 1913. Batavia, etc., 1914. (*Recd. 22/ii./15.*)
- Hertfordshire Natural History Society.**—Hertfordshire Maps...1579-1900. Parts I.-III. By H. G. Fordham. n.p., n.d. (*Recd. 19/i./15.*)
- Leicester.**—**Literary and Philosophical Society.** Wheat—and its Relation to the Present Crisis. By W. A. Evans. Leicester, 1914. (*Recd. 24/xi./14.*)
- London.**—**British Museum (Natural History).** Catalogue of Mesozoic Plants in...British Museum (Natural History). The Cretaceous Flora. Part I. By Marie C. Stopes. London, 1913. (*Recd. 15/x./14.*)
- — — A Revision of the Ichneumonidae. Part III. By Claude Morley. London, 1914. (*Recd. 15/x./14.*)
- — — **Greenwich Observatory.** Astrographic Catalogue 1900.0. Greenwich Section Dec. +64° to +90°, Vol. III. By F. W. Dyson and others. Edinburgh, 1914. (*Recd. 31/xii./14.*)
- — — **Meteorological Office.** On the Relation between the Velocity of the Gradient Wind and that of the Observed Wind. By J. Fairgrieve. (Geophysical Memoirs, No. 9.) London, 1914. (*Recd. 30/xi./14.*)
- — — The Effect of the Labrador Current...Temperature of the North Atlantic. Part II. By M. W. C. Hepworth. (Geophysical Memoirs, No. 10.) London, 1914. (*Recd. 30/xi./14.*)
- — — Report on the Work carried out by the S.S. "Scotia," 1913. London, 1914. (*Recd. 30/xi./14.*)
- — — Maps, Charts, and Diagrams to illustrate the Report...S.S. "Scotia," 1913. London, 1914. (*Recd. 30/xi./14.*)
- — — The South Wales Tornado of October 27, 1913. By H. Billett. (Geophysical Memoirs, No. 11.) London, 1914. (*Recd. 19/ii./15.*)

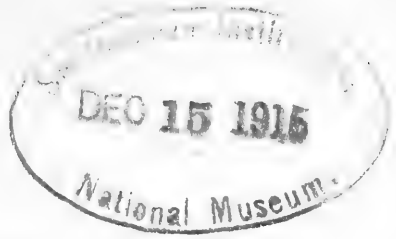

I. The Pennatulaceae of the Cape of Good Hope
and Natal.

By J. STUART THOMSON, Ph.D., F.L.S., F.R.S.E.,

Lecturer in Zoology, Victoria University of Manchester.

(Read October 20th, 1914. Received for publication November 17th, 1914.)

The Pennatulaceae described or recorded in this paper were collected during the years 1898-1907 by the Cape Government trawler, the *Pieter Faure*. The collection of Pennatulids is not so good as that of other sections of Alcyonaria, probably because little dredging was done off the Natal coast. The list of Pennatulids so far as these have come into my hands is as follows:—

- Actinoptilum molle*, Kükth.
- Actinoptilum molle*, Kükth. var. *maculatum*.
- Actinoptilum molle*, Kükth. var. *intermedium*.
- Actinoptilum molle*, Kükth. var. *zonatum*.
- Funiculina quadrangularis*, Pall.
- Virgularia Schultzei*, Kükth.
- Pteroeides*, sp.
- Pteroeides isoscelcs*, sp. n.
- Anthoptilum grandiflorum*, (Verr.) Köll.
- Umbellula aciculifera*, sp. n.

On account of the large number of exceptionally well-preserved specimens of *Actinoptilum molle*, a careful study of that species was possible.

January 19th, 1915.

Typical specimens of *Actinoptilum molle*, Kükth, or varieties of this species were collected by the *Pieter Faure* at the following localities:—

Pieter Faure, No. 687. Lat. $34^{\circ} 5' 00''$ S. Long. $25^{\circ} 38' 00''$ E. Taken by dredge.

Pieter Faure, No. 757. About 16 miles west of East London. Depth, 37-42 fathoms. By large trawl. Date, December 21st, 1898.

Pieter Faure, No. 791. Same locality. Date, December 27th, 1898.

Pieter Faure, No. 1,131. S.E. by E, 11 miles from Bird Island. Lat. $33^{\circ} 52'$ S. Long. $26^{\circ} 30' 45''$ E. By shrimp trawl. Depth, 54 fathoms. Bottom, mud.

Pieter Faure, No. 1,193. Cape St. Blaize, N. distant $4\frac{3}{4}$ miles. Lat. $34^{\circ} 15' 15''$ S. Long. $22^{\circ} 12' 30''$ E. By large trawl. Depth, 33 fathoms. Bottom, mud. Date, May 5th, 1899

Pieter Faure, No. 13,103. Off Beacon east of East London N.W. $\frac{3}{4}$ W. $6\frac{1}{2}$ miles. By shrimp trawl. Depth, 42 fathoms. Nature of bottom, sand with black specks. Date, July 24th, 1901. A number of specimens taken in this locality.

Pieter Faure, No. 14,430. Cape Hangklip, N.E. $\frac{3}{4}$ N. $28\frac{1}{2}$ miles. Depth, 100 fathoms. By shrimp trawl. Bottom, green sand. Date, February 26th, 1902.

Pieter Faure, No. 13,792. Rilt Point, N.E. by E. 2 miles. Depth, 23 fathoms. By dredge. Bottom, sand and rock. Date, September 9th, 1901.

Pieter Faure, No. 2,887. Robben Island, N.E. $\frac{3}{4}$ N. 3 miles. Depth, 27 fathoms. By large dredge. Nature of bottom: coral, sand, shells and rocks. Date, May 30th, 1900.

This list is as complete as I can now make it, but I know from my work in South Africa that *Actinoptilum*

molle was collected at numerous other localities; it is probably the most common Pennatulid in South African Seas.

Actinoptilum molle, Kükth.

Pieter Faure, No. 1,193. Locality, etc. Cape St. Blaize, north distant $4\frac{3}{4}$ miles. Lat., $34^{\circ} 15' 15''$ S. Long., $22^{\circ} 12' 30''$ E. Taken by large trawl. Depth, 33 fathoms. Nature of bottom, mud. Date, May 5th, 1899.

From this locality, I have an example of *Actinoptilum molle*, Kükth, which is singularly well preserved, with the autozooids completely expanded, forming a beautiful museum specimen. The general ground colour of the specimen is red or pink and the autozooids are white. The natural colours of the example are well retained by preservation in formalin, and by storing in a dull, subdued light. The distribution of colour on the surface of the colony may be noted, and regarded as approximately natural. The apex of the rachis is light pink, becoming slightly darker further down; in the lower part of the mid-rachis the colour commences to become violet-pink, and in the bud region at the base this violet-pink colour becomes more definite. The upper part of the stalk is a continuous violet-pink colour, and its lower part merges from yellowish-pink to pale yellow at the extreme base. The autozooids are almost transparent, or in the mass they have a faint or dull yellow appearance.

The dimensions of the various parts of the specimen are as follows:—

Total length, 146 mm.; length of rachis, 111 mm.; length of stalk, 35 mm.; width of rachis, 19 mm. at the rounded apex, 33 mm. at its maximum and 22 mm. at the base (the autozooids not being taken into consideration in these measurements). The greatest diameter of

the rachis, including the autozooids is about 49 mm. The expanded autozooids vary in length from 8 to 12 mm., being on an average 9.8 mm. long. The distance between the autozooids, taken transversely, varies from 1.4 to 2.4 mm., the average distance being 1.8 mm. The width of the stripes on which the autozooids are situated varies considerably, being wider at the centre than at the apex and base of the rachis. The width of these stripes varies from 2.5 to 4.3 mm., the average being 3.5 mm. The longitudinal distance between the autozooids varies from 1 or 2 mm. at the base of the rachis to 2, 3, or 4 mm. at the middle of the rachis. The calyces of the autozooids are 1 mm. in height.

The diameter of the siphonozooids is about 0.0276 mm.; the diameter of the lower part of an autozooid in cross section is about 1.012 mm. Expanded tentacles are approximately 1.748 mm. in length, 0.460 mm. transversely at the base, and 0.184 mm. at the apex.

The dimensions of the spicules are as follows:—

The long spicules vary from 0.56×0.04 mm. to 0.66×0.08 mm. The shorter spicules vary from 0.22×0.03 to 0.30×0.04 mm. The broad spicules vary from 0.11×0.03 to 0.30×0.05 mm.

My specimen undoubtedly agrees in essential characters with Kükenthal's description of *Actinoptilum molle*, only differing in minor points. The colour of Professor Kükenthal's specimens is slightly different. The calyces of the autozooids of my specimen are 3 or 4 mm. less in height. Professor Kükenthal describes on the calyces two large and six smaller teeth; while the two large teeth are apparent, the six smaller teeth are by no means obvious in my specimen even with the aid of a Zeiss binocular. As regards the spicules, those of the external part of the stalk have lines running parallel with

the margin at each end which are not represented in his figure.

The extreme length of the stomodaeum, the absence of spicules in the anthocodiae, and the presence of about 17 pairs of pinnules in each tentacle may be noted.

This species has been previously described by Hickson under the name *Cavernularia elegans*.

Pieter Faure, No. 1,131. South-East by East, 11 miles from Bird Island. Lat., $33^{\circ} 52'$ South. Long., $26^{\circ} 30' 45''$ East. Taken by shrimp trawl. Depth, 54 fathoms. Bottom, mud.

Four specimens which are undoubtedly to be identified as *Actinoptilum molle*, Kükth. Transverse sections through the colonies at different points show the same internal arrangement of parts figured by Kükenthal as being typical of *Actinoptilum molle*. Further description of these four specimens is unnecessary, except to note the variation in colour. Three of the examples have practically the same general coloration as *Pieter Faure*, No. 1,193; the fourth specimen has a yellow stalk and white rachis. These specimens are not, however, so beautifully expanded as the former specimen.

Actinoptilum molle, Kükth. var. *maculatum*.

Pieter Faure, No. 18,225. Cape Hangklip, N.E. $\frac{1}{2}$ East, $5\frac{1}{4}$ miles. Taken by large trawl. Depth, 60 fathoms. Nature of bottom, greenish mud. Date, Nov. 11th, 1903.

From this locality there are ten specimens of a reddish colour, which at a glance appear to differ from the preceding. The anthocodiae of the autozooids are white with reddish blotches on their surfaces, easily seen with the naked eye. On closer examination these red blotches are seen to be due to the presence of minute red spicules. The autozooids are well expanded, and the

pinnules of the tentacles are easily seen. The rachis is of a fairly bright red colour, but this coloration is mainly produced by the spicules of the calyces of the autozooids, the siphonozooids appearing as minute, circular, colourless areas between them. The calyces of the autozooids project 2 mm. above the surface of the coenenchyme, and the bright red spicules on their surface render them very conspicuous. The two projecting points of the calyces are very prominent in these specimens. The stalk is much paler in colour than the rachis, being a pale yellowish-red.

The dimensions of a colony are as follows :—

Length of specimen 95 mm., length of stalk 21 mm., length of rachis including apical autozooids 74 mm., length of anthocodiae 6 mm., height of calyces about 2 mm.

The more important points in the determination of these specimens are as follows :—

The autozooids are perfectly radially arranged, and with one exception there is no trace of a groove on the ventral surface of the rachis. The calyces of the autozooids show two prominent and six much less conspicuous teeth, the calyces and teeth are, however, by no means so marked as in the genus *Echinoptilum*. The anthocodiae of the autozooids have spicules, this being a character in which the specimens resemble *Echinoptilum* but differ from typical *Actinoptila*. In *Echinoptilum Macintoshii*, Balss, spicules occur on the tentacles, but not on the polyp wall.

Transverse sections show that the arrangement of the internal canals is that typical of *Actinoptilum* or *Echinoptilum*. The external transition between stalk and rachis is quite sharp. The stalk in transverse section is not, however, circular as described for *Echinoptilum*. The ratio length of stalk to rachis is 1 : 2 or 1 : 3.

Spicules of the internal part of the stalk are not so abundantly present as one would infer from Kükenthal's description of his specimens of *Actinoptilum molle*. It may, however, here be noted that the expression "stielinnern" leaves a large margin from which the spicules may be taken. The spicules of the outer cortex of the stalk are oval plates sometimes biscuit-shaped of variable size. They are in many respects similar to those described from this part by Kükenthal but appear to differ slightly in their superficial markings. The spicules of the cortex of the rachis and calyx are very numerous. They are of the flanged or ridged type described by Kükenthal as "dreiflügelig." The presence of minute corpuscular spicules arranged in eight longitudinal lines on the body wall of the autozooids and also the occurrence of these lining corpuscles on the tentacles are points distinguishing the specimens from typical examples of *Actinoptilum molle* as described by Kükenthal. The length of these minute spicules ranges from about 0.023 to 0.031 mm.

Actinoptilum molle, Kükenthal, var. *intermedium*.

Pieter Faure, No. 14,617. Four white specimens from this locality are of particular interest as they appear in some degree to afford a transition between the genera *Actinoptilum* and *Echinoptilum*.

The more important characters of these specimens are as follows:—

A trace of a ventral groove on the rachis, otherwise little trace of a bilateral arrangement of the autozooids; autozooids arranged in transverse and longitudinal rows; the spicules of the rachis are mainly "dreiflügelig"; there is no axis; the lateral teeth of the calyces of the autozooids are not very prominent; no spicules in the anthocodiae; the siphonozoids have rudimentary calyces.

The dimensions of the largest specimens are as follows :—

Entire length of colony 133 mm., length of rachis 105 mm., breadth of rachis 14 mm., length of stalk 28 mm., breadth of stalk 10 mm., relative length of stalk and rachis 1 : 3 or 1 : 4, length of autozoid calyx 1 to 2 mm.

The spicules from the outer and inner part of the stalk, from the outer and inner part of the rachis and from the calyces are essentially similar to those described and figured by Kükenthal for *Actinoptilum molle*.

There can be little doubt that these are true specimens of *Actinoptilum molle* which possess in the ventral groove of the rachis a feature of peculiar interest. The presence of a groove has not hitherto been observed in any *Actinoptilum*, and its presence in the genus *Echinoptilum* and absence in *Actinoptilum* has been held to be an important diagnostic character. This groove commences at the upper end of the stalk, and extends varying distances in different specimens, namely from 7 to 33 mm. The arrangement and degree of development of the autozooids is also slightly modified on each side of the groove.

The specimens are, however, distinct from *Echinoptilum* in the smaller calyx, in the very slight groove and by the autozooids being developed in an almost completely radial manner. In this connection, I have been able to refer to a very distinctive new example of the genus *Echinoptilum* in the Siboga collection which has been named *E. roseum* by Hickson.

Specimen A.

Actinoptilum molle, Kükth. var. *zonatum*. The number indicating the exact locality had unfortunately become obliterated in the formalin.

The specimens are interesting on account of the distribution of the colour in rings or bands.

In the smallest specimen the stalk is of a deep yellow colour. The colour of the rachis varies at different parts, namely, it is white for about half the distance from the base where it has a light-brown band, above this it is again white, changing to a pale red at the apex. In the second specimen the stalk is a yellowish-red. The rachis has a white ground for half the distance from its base, in this part the coenenchyme and calyces are white, but the anthocodiae appear as reddish brown patches, following this there is a broad band in which the coenenchyme, calyces and anthocodiae are red in colour, lastly, the apical portion of the rachis resembles the basal portion. The third and fourth specimens resemble one another in colour. The stalk is light yellow, the lower portion of the rachis has a white ground, and the anthocodiae are light brown, then follows a band in which the coenenchyme, calyces and anthocodiae are all light-brown; lastly, the apical part has a white ground, and the anthocodiae and calyces are light brown or light pink.

The wall of the stalk is very thin, and thus has a bladder-like appearance. The stalk is sharply marked off from the rachis. The calyces of the autozooids and siphonozooids are both extremely obvious, those of the former have six small and two larger teeth.

The form of the colony is somewhat cylindrical, and the body is only slightly curved inwards. The relative length of stalk and rachis is 1 : 2.5 or 1 : 3. This ratio apparently varies according to the degree of preservation. On one side about the middle, the stalk decreases very much in width, basally it ends bluntly.

The following dimensions were taken from three specimens :—

No. of Colony.	I.	II.	III.
Length in mm.....	102	88	77
<i>Rachis.</i> Length in mm.	70	66	61
Breadth in mm.....	20	17	18
<i>Stalk.</i> Length in mm.	32	22	16
Breadth in mm.....	14	13	15

The following are the chief characters of the specimens:—

Radial arrangement with curved rachis, no trace of external bilateral symmetry, autozooids arranged in transverse and longitudinal rows and provided with calyces. Siphonozooids lying between the autozooids. No axis. Spicules of rachis "dreiflügelig." No ventral groove on the rachis. The authocodiae have spicules.

In his diagnosis of the genus *Actinoptilum*, Kükenthal states that the autozooids have no spicules, if this were to be taken as conclusive, then these specimens and others already mentioned must be excluded from the genus *Actinoptilum*. Kükenthal is probably right when in discussing the genus *Cavernularia* he says that the presence or absence of spicules in the polyps cannot be regarded as a generic character. One might, however, proceed a step further, and ask if the presence or absence of the spicules in the polyps should be regarded as a specific character.

In the outer part of the stalk, the spicules are very similar in shape to those described and figured for *Actinoptilum molle*; they are between 0.184 and 0.024 mm. in length. Among them are a few of the flanged type. In

the interior of the stalk there are only a few minute spicules. In the outer cortex and interior of the rachis, and from the calyces, the spicules are also similar to those of *Actinoptilum molle*, Kükth. The spicules which have not been described for *Actinoptilum molle* are minute, ovoid calcareous bodies with a few central markings and striae concentric with their ends. They are about 0.046 mm. in length or may be even shorter. The calyces of the autozooids are about 2 mm. in height.

These specimens show very marked affinities with *Actinoptilum molle*, one marked difference being the occurrence of calcareous corpuscles in the anthocodiae. They are excluded from the genus *Echinoptilum* by the short calyx and completely radial arrangement of the autozooids. They agree with Kükenthal's genus *Actinoptilum* in the radial arrangement of the autozooids, in the disposition of the autozooids in longitudinal and transverse stripes, in the small calyces of the autozooids, in the rudimentary calyces of the siphonozooids and in the general shape and arrangement of the spicules. They decidedly differ from typical *Actinoptila* in the occurrence of spicules in the anthocodiae.

Specimen B.

Actinoptilum molle, Kükth. Six specimens from South African waters of which the exact location is not known as unfortunately the numbering on the label in the jar had disappeared. I have no hesitation in determining these specimens to be *Actinoptilum molle*, Kükth. They agree with the description and with a specimen from South Africa which had been lent by Professor Hickson to the Zoologist of Breslau. One point which these specimens showed better than the other examples from Cape St. Blaize was the division of the calyx into two large and

six smaller points. The stalk is brick-red or orange-red, the rachis dark red, and the autozooids and siphonozooids yellow or white. The rachis has no trace of a ventral groove, and the autozooids are completely radially arranged.

Actinoptilum molle, Kükth.

Pieter Faure, No. 13,103 A. Off Beacon east of East London, N.W. $\frac{3}{4}$ W. $6\frac{1}{2}$ miles. Taken by shrimp trawl. Depth, 42 fathoms. Nature of bottom, sand with black specks. Date, July 24th, 1901.

A beautifully expanded white, almost transparent, specimen; with a simple lens one can easily see the pinnules, the mesenteries, mesenterial filaments, and the long stomodaeal part. The autozooids are very definitely arranged in longitudinal and transverse rows. Between every two autozooids in a longitudinal row there are 8-12 siphonozooids; the latter are slightly raised above the surface of the coenenchyme. The stomodaeal part of the autozooids is retractile within the calyces, but the tentacles appear at the opening. There are no spicules in the anthocodiae nor in the calyces. The tentacles have 20-24 pairs of pinnules. The dimensions of the single specimen are as follows:—

Entire length 76 mm., length of rachis including projecting autozooids 67 mm., length of stalk 9 mm., breadth of rachis at its widest part excluding projecting autozooids 16 mm., length of expanded autozooids including calyx 12 mm., length of calyx 8 mm., expanded tentacles of the autozooids about 3 mm. in length, diameter of spread of tentacles about 7 mm., diameter of calyx at base about 3 mm., diameter of siphonozooids 0.368 mm.

The pinnules of the tentacles are very long and narrow when extended; there are about twenty-one pairs in each

tentacle. The spicules of the rachis and stalk resemble those of a typical *Actinoptilum molle*, but are much less abundantly distributed.

The rod-like spicules of the rachis are about 0.184×0.095 or 0.386×0.0386 mm. The rod-like spicules of the stalk vary from 0.478×0.048 to 0.202×0.027 mm.; the shorter plate-like spicules are 0.119×0.055 to 0.082×0.036 mm.

The specimen is very soft, but so far as one can make out without totally injuring the example, the canals are arranged more after the *Actinoptilum* than the Cavernularian plan. No axis is present in the colony.

This form may, from the apparent absence of spicules in the calyces, eventually turn out to be of great systematic importance, but it would be incautious to say anything more definite without further examples.

It may be doubted whether Kükenthal and Broch's classification of the radial Pennatulaceae as given below is entirely satisfactory. In my opinion some such tabulated classifications are without sufficient facts to support them, and are premature.

1. Without autozoid calyces.

Fam. 1. Veretillidae.

- (a) Autozoid spicules branched apically.
- (aa) Stalk spicules plate-shaped—1. Lituaria.
- (bb) Stalk spicules rod-like or bone-like—2. Cavernulina.
- (b) Autozoid spicules not branched.
- (ccc) Spicules plate-shaped.
- (a) Spicules only in stalk, rachis without spicules. Pollicella.
- (b) Rachis with spicules—Veretillum.
- (dd) Spicules oval to rod-like—Cavernularia.

2. With autozoid calyces.

Fam. 2. Echinoptilidae.

- (a) Autozooids completely radially arranged. *Actinoptilum*.
- (b) Autozooids radially arranged, but commencement of external bilateral symmetry. *Echinoptilum*.

This classification raises the doubt whether different authorities on this group are agreed in their conceptions of a calyx. Kükenthal's definition of a calyx is as follows : " Unter einem Polypkelche verstehen wir das verdickte untere Mauerblatt des Polypen, welches mehr oder minder scharf von dem oberen abgesetzt ist, und in welchen sich der obere weichhäutigere Polypenteil zuruckziehen lassen." He regards the presence or absence of a calyx so understood as a character of families or genera. It may be stated in passing that if my specimen, *Actinoptilum molle*, Pieter Faure, No. 13,103, is adequately preserved, then according to the latter part of this definition the distinction between the Fam. Veretillidae and Echinoptilidae breaks down.

Kükenthal also holds that the form and arrangement of the spicules is characteristic of each species, and that the presence or absence of spicules in the tentacles is important in this connection. In my opinion, other points being similar, the presence or absence of spicules in the tentacles would only constitute a variety, especially if these spicules were of the minute corpuscular type. In the genera *Actinoptilum* and *Echinoptilum* an important point is not so much the presence or absence of a ventral groove on the rachis, but the radial or non-radial symmetry of the autozooids. I hold that while the genus *Actinoptilum* shows affinities with the genus *Echinoptilum*, it also exhibits as close affinities with *Cavernularia*, more

especially as regards the arrangement of the autozooids in a completely radial manner. The distinction between the genera *Actinoptilum* and *Echinoptilum* is obvious, much more obvious than between *Actinoptilum* and *Cavernularia*. It appears to me unnecessary to constitute a family Echinoptilidae at all.

In his diagnosis of the genus *Echinoptilum* and *Actinoptilum*, Kükenthal remarks on the presence of spicules in the autozooids of the former, but their absence in the latter. On pages 5 and 10 I point out the presence of spicules in the autozooids of typical *Actinoptila*; it is more probable that his previous statement in discussing *Cavernularia* is the right one, namely, that the presence or absence of spicules in the autozooids cannot be regarded as a generic character.

Funiculina quadrangularis, Pall.

Pieter Faure, No. 12,006. Cape Vidal (Natal). N.N.E. $\frac{1}{4}$ N. $9\frac{1}{2}$ miles, 80—100 fathoms. Taken by dredge. Nature of bottom, rocky. Date, February 27th, 1901.

This specimen is about 49 cm. in length, it expands at the base, and tapers at the apical extremity. The axis is quadrangular with a thin coenenchyme covering it, and the autozooids arranged ventrally and laterally. The diameter of the axis plus the covering coenenchyme, is 3.1 mm. at the expanded base, at the middle of its height 1 mm., near the apex .8 mm. The autozooids occur in different stages of development, the larger are about 3 mm. in length including tentacles and 1 mm. in diameter at their widest region, the smaller near the apex of the colony are 2 mm. in length and 1.2 mm. in diameter at the widest part. The autozooids have well-developed calyces running out in eight pointed teeth. Minute

siphonozoods occur on the surface of the coenenchyme, but apparently not very abundantly.

The spicules from all parts agree with the figures and description given by Kükenthal, to whom we are indebted for a searching account of this species, the only point in which my specimen differs from his description is in the absence of a broad transverse band of spicules at the base of the calyx and of a band of spicules at the base of the eight teeth into which the spicules project. Marshall does not figure these circular bands, and my specimen in this respect seems more to resemble his. This point does not, however, appear to justify the formation of a new species.

Funiculina quadrangularis was taken during the cruise of the "Valdivia" in the Pemba Canal, Zanzibar, at depths of 818 and 863 metres. The species has a wide distribution, namely, the North Atlantic, Mediterranean, Indian Ocean (Zanzibar and Natal), and the Pacific Ocean (New Zealand).

Virgularia Schultzei, Kükth.

Localities :—*Pieter Faure*, No. 14,923. Saldanha Bay, between Marcus Island and Hoetjes Bay. Taken by dredge. Depth, 10-40 fathoms. Nature of bottom, sand and mussel beds. Date, March 19th, 1902.

Pieter Faure, No. 3,034. Cape Point Lighthouse, N.W. by W. $\frac{1}{4}$ W. $11\frac{3}{4}$ miles. Depth, 45 fathoms. Taken by dredge. Nature of bottom, mud. Date, June 6th, 1900.

This species has previously been described by Hickson as *V. Reinwardti* and also by Kükenthal. It was also collected during the cruise of the "Valdivia" in Plettenberg Bay, S. Africa, at depth of 100 metres, and in Lüderitz Bay (British South-West Africa).

Anthoptilum grandiflorum (Verr.), Köll.

Pieter Faure, No. 2,143. Lion's Head, S. 72° E. 47 miles. Depth, 190 fathoms. Taken by large dredge. Nature of bottom, green sand with black specks. Date, March 16th, 1900.

This specimen occurs in abundance at certain localities in South African waters, and has already been recorded by Hickson.

Pteroeides, sp.

Pieter Faure, No. 18,491. Bird Island Lighthouse, W.N.W. 7 miles. Depth, 38 fathoms. By large trawl. Nature of bottom, dark sand. Date, April 12th, 1904.

The specimen is broken off near the base of the rachis, and its determination thus hampered by obvious difficulties. The following points are given in the hope that further specimens may be secured:—

At least 44 leaves are present, which overlap in the median line, covering the meta-rachidial surface except a bare space near the base. The leaves are thick, do not expand to any extent at the base and have 23 rays projecting to a slight extent beyond the autozoid zone; the upper leaves become much folded. The autozooids occur on both margins of the leaves, and are arranged in about three rows on each side—the siphonozoid plate is median. The rachis is about as long as broad; no siphonozoid groove observed. The centre of the rachis is firm; the gonads are developed.

Pteroeides isosceles, sp. n.

Pieter Faure, No. 19,061. Off Bird Island (E. London), east, 3-4 miles. Taken by large trawl. Depth, 32-38 fathoms. Nature of bottom, mud. Date, November 28th, 1900. Only one specimen taken.

Dimensions:—Total length of colony (including over-

lapping terminal leaves) 173 mm., length of rachis (with overlapping terminal leaves) 88 mm., breadth of rachis 87 mm., length of stalk 85 mm., diameter of stalk immediately beneath rachis 22 mm., number of leaves 46, number of rays 19, length of pro-rachidial margin of largest leaf 38 mm., breadth of insertion of largest leaf 12 mm., distance between insertion of leaves 2 mm.

The stalk is much expanded in a globular manner a short distance beneath the rachis, and at the base it also enlarges and ends in a rounded point. Numerous short, rod-like spicules are seen with a lens on the surface of the stalk and rachis. The ratio length of rachis and stalk is about 1 : 16 (the rachis measurement not taking into account the terminal overlapping leaves). The ratio breadth of rachis to length of rachis, including the leaves, is 1 : 5.4. Ventral siphonozooids are present on the rachis at the upper end.

The leaves of opposite sides approach or overlap one another medianly, and cover the meta-rachidial surface except for an area shaped like an isosceles triangle at the base. This bare area is about 37 mm. in length. The pro-rachidial surface is entirely free. The leaves are about 4 mm. in thickness, and are shaped somewhat like a fan which is completely extended one half. Each leaf expands at its meta-rachidial insertion, but there is no stipule. Two leaves at the base of the rachis are rudimentary, the last one not being more than 2-3 mm. in length. The leaves are thick on the meta-rachidial, thin on the pro-rachidial margin.

In the leaves at the middle of the rachis, there are 18-20 strongly developed rays which sometimes project 3 mm. beyond the leaf margins, and are each built up of about five spines. The ray of the pro-rachidial margin of each leaf is much stronger than the other rays.

About three rows of autozooids occur on the meta-rachidial and pro-rachidial surface of the leaves, they are yellowish in colour, and the tentacles white. The smaller spicules of the leaves are arranged round and parallel to the anthocodiae, apparently forming a very complete means of protection. There are blackish patches on the autozoid areas of the meta-rachidial surface of some of the leaves. The siphonozoid plate is median extending far up the leaf. Well developed gonads are seen on the meta-rachidial surface of the leaves underneath the autozooids.

The spicules of the outer part of the stalk are rod-like, but rounded off at each end where they are also slightly crenated. They have a number of longitudinal lines on the surface, and also at each of the long ends there are concentric lines. Their size varies from about 0.1004×0.007 to 0.1656×0.023 mm. The spicules of the rind of the rachis are very similar to those of the outer part of the stalk, but they terminate rather more pointedly, and are rather longer. The larger spicules are about 0.2300×0.030 mm. The spicules of the leaves are long rods. No spicules occur in the inner part of the stalk, nor in the inner part of the rachis.

The species of the genus *Pteroeides* appear to vary so much that it is difficult to fix upon the characters which should be used in their identification.

Hickson holds that the least variable characters are :
(1) The arrangement and number of the rays in the leaf.
(2) The character and size of the spicules of the outer cortex of the stalk. (3) The number of leaves. (4) The ratio between width and length of the rachis.

This species appears to be new and belongs to Kölliker's group of *Pteroeides pellucidum*. I regret to add another species to the long list in this genus. Few

species of the genus *Pteroeides* have been recorded from the African coast or from the Indian Ocean. *Pteroeides brachycolon*, Köll., has been recorded from Zanzibar, *Pt. pulchellum*, Th. and H. from the Wasin Canal, E. coast of Africa, and *Pt. robustum*, Th. and Simpson from the same locality.

Umbellula aciculifera, sp. n.

Pieter Faure, No. 17,026. Cape Point (100—900 fathoms) N.E. by E. $\frac{1}{4}$ E., 46 miles. Bottom, green mud. Date, July 21st, 1903.

A solitary specimen was procured from this locality, the dimensions of which are as follows:—

Length of colony probably about 460 mm., length of lower expanded part of stalk 50 mm., length of a long autozoid 33 mm., length of body of autozoid 26 mm., approximate length of tentacle 8 mm., breadth of axis 3 mm., number of autozooids in apical rosette 10, length of needles of tentacles 0.294 mm., length of corpuscles of stalk 0.10 mm., diameter of siphonozoid about 0.10 mm.

The stalk has an enlargement at the upper end continuous with the rachis and another expansion at the lower end. Owing to the stalk having been broken, the relative dimensions of this lower expanded part of the stalk cannot be given. The stalk is obviously quadrangular externally in its upper part, but lower down it tends to become rounded, though even at this part if a rough section is made the axis is seen to be quadrangular, with, however, a tendency to a circular or oval form. The stalk slightly beneath the apical rosette of nine autozooids, which surround a more or less central one, is compressed bilaterally. It has a curious bend by which these apical autozooids are disposed almost at right angles to the lower stalk. One cannot, however, lay stress on this

point, as the specimen was twisted in a small specimen jar. The specimen is interesting from the occurrence of four epizoic zoantharia which are closely adherent to the central stalk of the colony.

The autozooids of the apical rosette do not all rise from the same level, more especially there are two which originate at a lower level and are more externally disposed than the others. The arrangement of the autozooids in the apical rosette, may be described as indistinctly bilateral. The following figure illustrates a diagrammatic

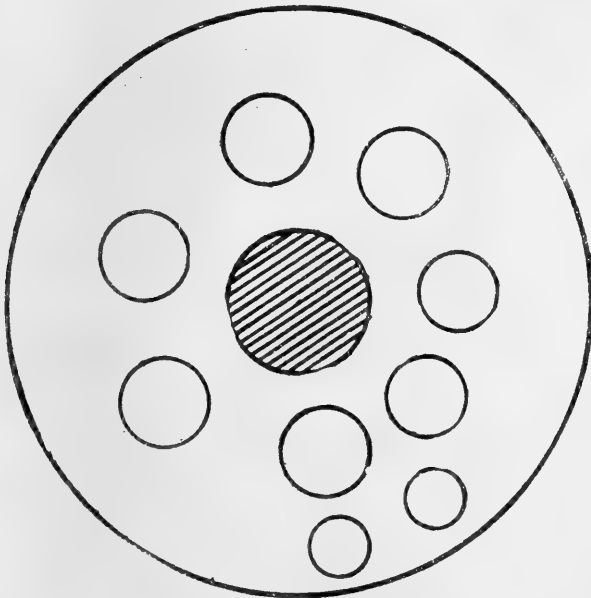

transverse section through the apical rosette of autozooids.

The axis of the stalk terminates at the base of the apical or central autozoid. The longer tentacles of the apical autozooids are about half the length of the body of the autozoid, the smaller only one-third. The pinnules of the tentacles are arranged opposite one another. Gonads are present in the apical autozooids.

The siphonozooids occur on the dorsal and ventral aspect of the rachis and penetrating between the autozooids; they also occur here and there on the stalk,

but partly owing to the state of preservation of the specimen, I am unable to state their exact arrangement on the latter. The single branched tentacle described for *U. carpenteri* was not observed. Spicules occur on all external parts of the colony, stalk, rachis, autozooids and their tentacles, they are also present in the inner part of the stalk. The spicules of the inner part of the stalk (of which there are only a few) and outer rachis are very minute. The spicules from all parts have ribbed or toothed margins.

The spicules of the tentacles are long needles or rods with ribbed or tooth margins—the longest are about 0.294×0.030 mm. in size. The spicules of the outer walls of the bodies of the autozooids are corpuscular or plate-like; they have short curved longitudinal lines on their surface, but no nucleus similar to that described in those of *Umbellula carpenteri*. The spicules of the outer lower stalk are very similar to the last in shape, but usually with a more entire margin. Their surfaces have longitudinal lines like those from the body of the autozooids. The largest are about 0.1104×0.06 mm. There are also some needle-like spicules approaching those of the tentacles in shape. The spicules of the outer upper stalk are similar to those of the outer lower stalk but broader; their size is about 0.1004×0.30 mm. The spicules of the more internal part of the stalk are very similar to the last in shape.

My specimen shows a number of points of resemblance with *Umbellula carpenteri*, Köll. The following points of agreement may be noted. They are both indistinctly bilateral in regard to the arrangement of the apical autozooids. The stalk has an upper and lower enlargement. The siphonozooids are on both the dorsal and ventral aspects of the rachis. The axis is mainly

quadrangular. The length of the largest colony is approximately the same. The axis ends at the base of the apical polyp. The more obvious distinctions between my specimen and *Umbellula carpenteri* are as follows:—

The spicules are found not only in the lowest part of the stalk, but all over the colony including the tentacles of the autozooids. The length of the body of the autozooid is distinctly longer in my specimen, viz., 26 mm. in contrast to 14 or 15 mm. in Kölliker's specimen. The length of the autozooid (including tentacles) is smaller in my specimen, namely, 33 mm. as against 43-83 mm. in Kölliker's specimen. Jungersen gives the length of the tentacles in *Umbellula carpenteri* as being 10, 15 and 20 mm.; in my specimen they are only 8 mm. The calcareous corpuscles described for *Umbellula carpenteri* are much shorter, namely, 0.012 mm. as compared with 0.110 mm. in my specimen. Further, no nuclei in those corpuscles such as described for *Umbellula carpenteri* are seen.

The species *Umbellula rigida*, Kükth. *U. Köllikeri*, Kükth. and *U. carpenteri*, Köll., are very closely allied. I am doubtful whether the two former species should ever have been regarded and named as separate species. Further, Kükenthal and Broch have made some mistake in their Memoir in drawing up the distinctions between those forms regarding the relative length of tentacle and autozooids, and contradict themselves. In comparing *U. rigida*, Kükth., and *U. carpenteri*, Köll., they say: "Auch sind bei letzterer Form die Tentakel länger als der Polypenkörper bei *U. carpenteri*, nach der Zeichnungen zu erteilen, kurzer" (pp. 293 and 294. "Valdivia" Report).

In comparing *U. carpenteri* and *U. Köllikeri*, Kükth. They write "Auch sind die Tentakel länger wie der Polypenkörper, bei *U. Köllikeri* dagegen bedeutend

kurzer." In his plate of *Umbellula rigida*, the tentacle is figured as shorter than the length of the body of the autozoid, and in his figure of *U. Köllikeri*, it is not always obvious that the tentacle should be if their text is correct distinctly shorter than the body of the autozoid. My specimen also exhibits some affinities with *U. thomsoni*, more especially regarding the needles in the tentacles.

After some hesitation, I have come to regard this as a new species, closely related to *U. rigida*, *U. Köllikeri*, *U. thomsoni* and *U. carpenteri*. *U. rigida*, Kükth. occurs in the Indian Ocean at a depth of 2,919 metres, *U. Köllikeri*, Kükth. occurs off the E. African coast at 1,668 metres, and *U. carpenteri* in the Antarctic.

I have pleasure in expressing my indebtedness to Dr. J. D. F. Gilchrist for entrusting these Pennatulaceae to me for description, and to Professor S. J. Hickson, F.R.S., for valuable suggestions, for facilities in comparing specimens and great help with the literature.

THE MORE IMPORTANT LITERATURE
REFERRED TO.

- BALSS, H. (1910). "Japanische Pennatuliden: Beiträge zur Naturgeschichte Ostasiens"—Doflein. *Abh. Math. phys. Klasse der bayr. Akad. d. Wiss.*, 1 Supplement-band.
- BROCH, HJ. (1910). "Pennatuliden." *Zoolog. u. anthropol. Ergeb. einer Forschungsreise im westl. u. centr. Südafrika*. Schultze, Vol. IV., 1 Lief.
- HICKSON, S. J. (1900, 1904). "The Alcyonaria and Hydrocorallinae of the Cape of Good Hope." *Marine Investigations in South Africa*. Cape Town, Pt. I., 1900, Pt. II., 1904.
- HUBRECHT, A. (1886). "On a new Pennatulid from the Japanese Sea (*Echinoptilum Macintoshii*)." *Proc. Zool. Soc.*, London, p. 512.
- JUNGERSEN, H. F. E. (1904). "Pennatulida." *Danish Ingolf Expedition*, Vol. V., No. 1.
- (1907). "Pennatulida." *Résultats du Voyage de S. Y. 'Belgica,' Anvers*.
- KÖLLIKER, A. (1872). "Anatomisch-systematische Beschreibung der Alcyonarien. Die Pennatuliden." *Abhandl. d. Senckenberg. naturf. Ges.*, Vol. VII. and VIII.
- (1880). "Report on the Pennatulida." *Rep. Scient. Res. of the Voyage of H.M.S. 'Challenger,' etc.*, Vol. I., Pt. II.
- KÜKENTHAL, W. (1910). "Pennatuliden der Deutschen Tiefsee—Expedition." *Zoolog. Anz.*, Bd. 36, p. 51.
- KÜKENTHAL, W., und BROCH, HJ. (1911). "Pennatulacea." *Wissenschaftliche Ergebnisse der deutschen Tiefsee—Expedition auf dem Dampfer 'Valdivia,' 1898-1899*, Fischer, Jena.
- NUTTING, CHARLES C. (1908). "Descriptions of the Alcyonaria collected by the U.S. Bur. of Fisheries steam trawler Albatross in the vicinity of the Hawaiian Islands in 1902." *Proc. U.S. Nat. Mus.*, Vol. XXXIV., p. 543.
- THOMSON, J. A., and HENDERSON, W. D. (1906). "The Marine Fauna of Zanzibar and British East Africa, from Collect. made by Cyril Crossland in the years 1901-2." *Proc. Zool. Soc.*, London.

EXPLANATION OF PLATES.

PLATE I.

Pteroeides isosceles, sp. n. (nat. size), and portion of leaf enlarged.

PLATE II.

Fig. 1.—Spicules from the outer part of the stalk of *Umbellula aciculifera*, sp. n. × 230.

Fig. 2.—Spicules from the tentacles of *Umbellula aciculifera*, sp. n. × 390.

Fig. 3.—Spicules from the calyces of *Actinoptilum molle*, var. *zonatum*. × 82.

Fig. 4.—Spicules from the anthocodiae of *Actinoptilum molle*, var. *maculatum*. × 330.



E. R. Dust, del.

Pteroeides isosceles, sp. n.

Bemrose, Colo., Derby.

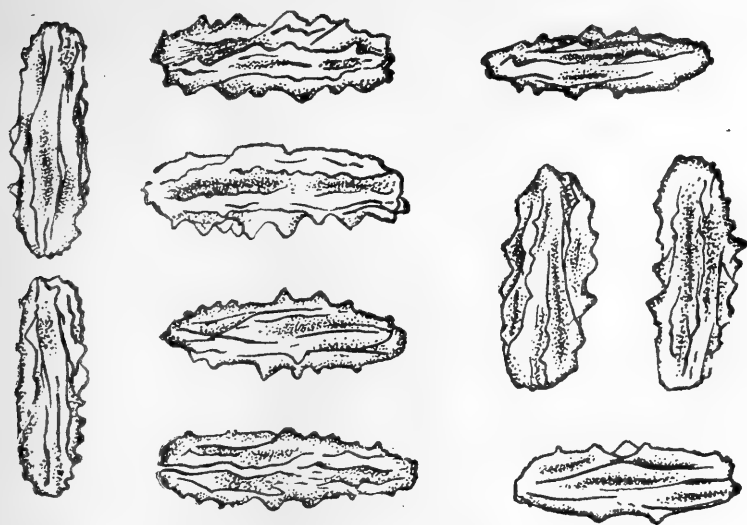

Fig. 1.

× 230

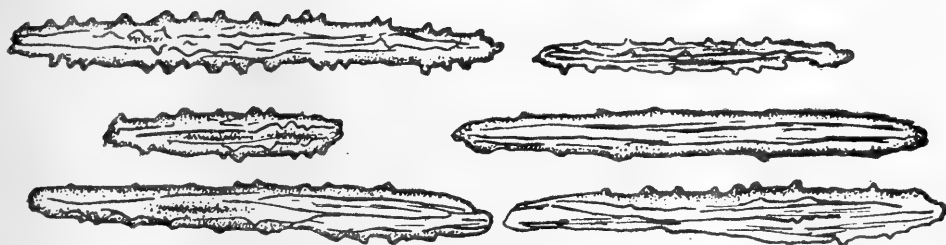

Fig. 2.

× 390.

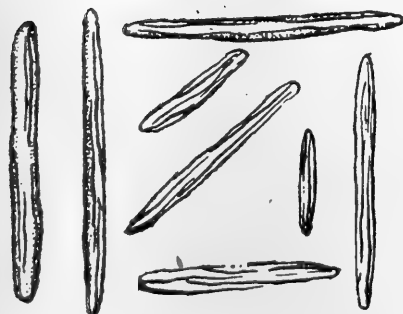

Fig. 3.

× 82.

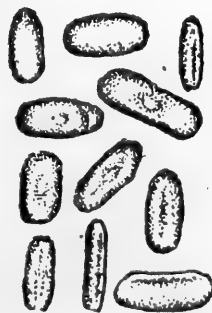
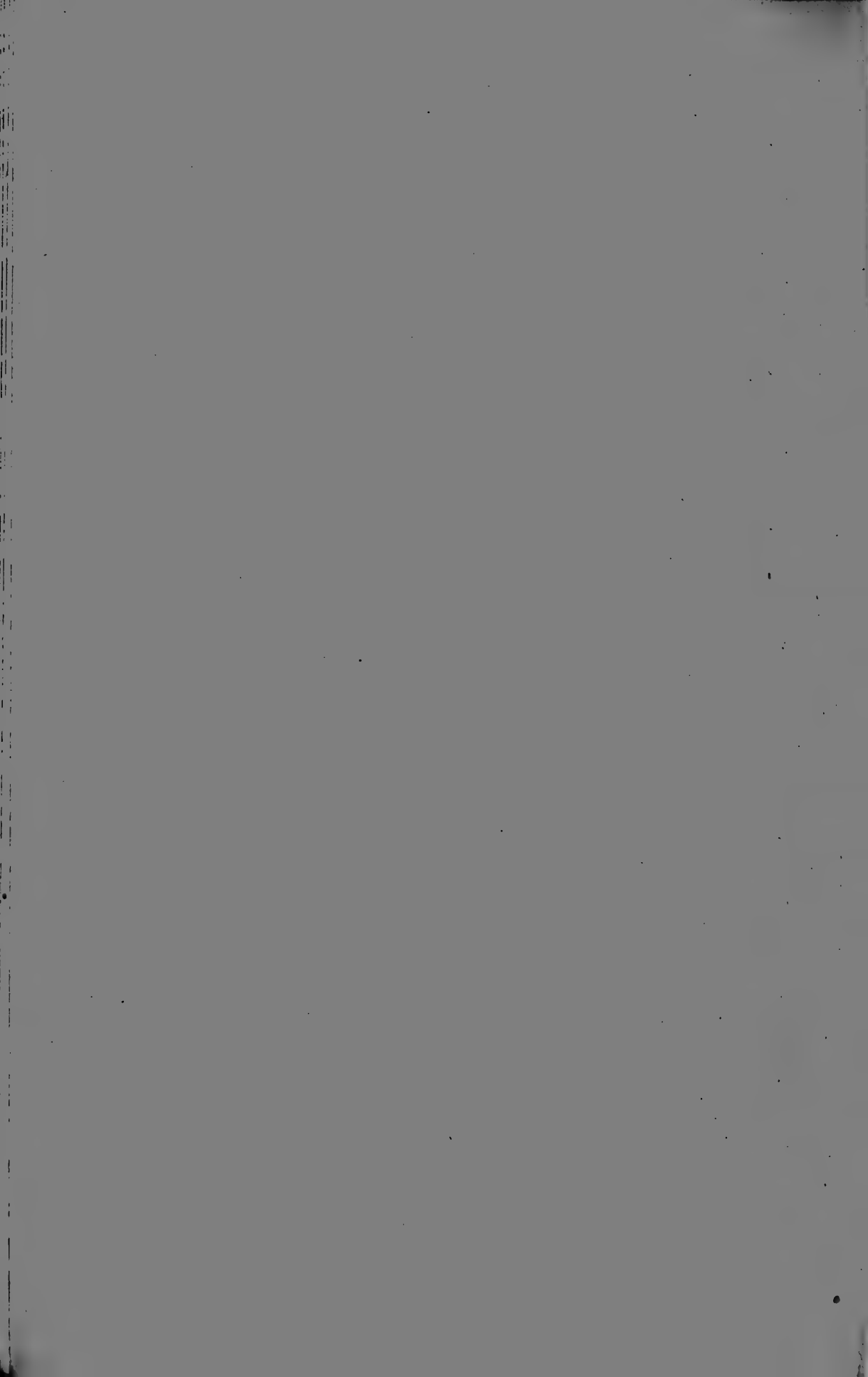

Fig. 4.

× 330.



II. Graphical Determination of the Stresses in the Main Spars of Monoplanes.

By CECIL H. LANDER, M.Sc., A.M.Inst.C.E.,

Lecturer in Civil Engineering in the University of Manchester.

(Read and received December 1st, 1914.)

One of the most complex problems connected with the design of beams continuous over several supports is presented by the spars of aeroplanes, particularly those of the Monoplane class. The stresses in the spar are made up of direct compressions together with those due to bending moments and the stress at any point may be represented by the expression

$$f = \Sigma \frac{P \cos \theta}{A} \pm \frac{My}{I}$$

where P = Pull in a bracing wire.

θ = Inclination of bracing wire to horizontal.

A = Sectional area of spar.

y = Distance of point under consideration from neutral axis.

I = Moment of inertia of spar.

M = Total bending moment at the point under consideration.

The value of M at any point may be made up of three terms due to three distinct causes.

1°. The more or less uniform loading due directly to the weight of the machine.

2°. Moments due to the attachment of the bracing wires not lying in the neutral axis of the spar.

January 20th, 1915.

3°. Moments due to the axial or endlong loadings acting through distances equal to the deflections of the spar from its initial position.

In actual flight the intensity of load is continually changing, thus altering the loads on the bracing wires and causing these latter to extend and contract slightly. On this account the assumption that the points of support are fixed is slightly inaccurate but owing to the slenderness of the spar the errors introduced by slight changes in alignment are small and their effect on the actual spar may be estimated with fair accuracy when the design is complete.

The assumptions made then in obtaining the preliminary dimensions are that the points of support remain in the same straight line.

When designing a spar it is always necessary to take into account the direct compression which is represented in the above expression by

$$\Sigma \frac{P \cos \theta}{A}$$

and the moment due to the first of the three causes enumerated. These moments may be obtained very simply by the Claxton Fidler method of solving beams continuous over several supports and which is as follows :

B.M. diagram for Aeroplane having wires attached at neutral axis.

If the bending moment diagrams be drawn upon a horizontal base line for each span as though it were discontinuous, then the true base line from which moments should be measured in order to determine those on the continuous beam, passes over and under certain characteristic points on each side of the support by equal amounts

if the spans be equal, or by amounts inversely proportional to the spans if the spans be unequal.¹ The characteristic points are obtained by setting up at a distance of one-third of the span from the support a perpendicular equal in length to

$$\frac{2 \Delta \bar{x}}{L^2}$$

where Δ = Area of bending moment diagram which would be produced on the span if it were discontinuous.

\bar{x} = Distance of centre of gravity of free ended bending moment diagram from the further support.

The distances by which the base line passes over or under the characteristic points on either side of a support, when multiplied by the span in which the point lies, can be shown to be proportional to the slope of the beam at the nearer support, and hence since there are two characteristic points to each support, the base line must pass over one and under the other by equal or proportional distances.

The above statements are only accurately true if the supports lie in the same straight line. If any support lies below or above the line of the other props by a known amount the method still holds, but other expressions are necessary for the heights of the characteristic points above the free ended base line.

In order to obtain the complete bending moment diagram for a continuous beam it is necessary then, firstly, to draw upon a horizontal base line the bending moment diagrams for each span assumed discontinuous; secondly, to determine the position of each pair of char-

¹ "Bridge Construction." Claxton Fidler.

acteristic points; and thirdly, to draw a broken line such that it passes over and under the characteristic points on each side of every support by equal distances, or distances inversely proportional to the span.

As an example this method has been used in drawing the bending moment diagram, *Fig. 2*, for a spar of 15' 9" span, supported at equal distances of 4' 6" apart by wires as shown (*Fig. 1*), and having a small cantilever portion at the tip. The loading has been taken as amounting to 40 lbs. per foot run. The moment at *B* was calculated as being that due to the cantilever loading lying to the left of *B*. The three parabolic diagrams are drawn as though the three spans were discontinuous and their maximum ordinates will therefore be equal to 101 ft. lbs. To determine the base line, the separate spans were divided into three equal parts and perpendiculars *ii'*, *jj'*, *kk'*, *ll'* erected equal in length to two-thirds that of the maximum height of the parabolas, since this is the value of the expression

$$\frac{2 \Delta \bar{x}}{L^2}$$

when the load is uniformly distributed. The base line was then drawn so as to make the bending moment at *B* equal to the cantilever bending moment, and so as to pass over and under the characteristic points *i*, *j* and *k*, *l* on each side of each support by equal amounts, and finally to give a value of zero for the bending moment at the right extremity since a flexible attachment to the fuselage is assumed at this point. This base is represented by the broken line *abcde* in the drawing. The moments at *C* and *D* will be given by *cg* and *dh*, and amount to 55 ft. lbs. and 88 ft. lbs. respectively. The maximum bending moment occurs at *B* and is equal to 101 ft. lbs. If the load had varied irregularly or had decreased uniformly from the chassis to the wing tip, the

same method could have been followed through, the only modification being that the height of the characteristic points instead of being taken as two-thirds the maximum ordinate of the parabola would have been calculated from the expression given above.

Bending Moment Diagrams for Aeroplanes having wires attached at points away from the neutral axis.

The usual points of attachment of bracing wires are arranged as near as possible to the under surface of the spar, and they therefore lie at a minimum distance equal to half the depth of the spar from the neutral axis. Bending moments of considerable magnitude are induced thereby, and it is necessary to provide for these moments when calculating the scantlings required. This system of attachment has probably been adopted in order to allow the canvas to lie smoothly along the bottom surface of the spar, but there appears to be no reason why a light aluminium housing should not be provided round which the fabric might be trimmed, and which would allow the wire to pass through the plane of the lower surface of the wing and be attached in the correct position. In a number of existing machines the theoretical factor of safety on the greater proportion of the length of the spar would be nearly doubled thereby. Where, however, the standard method of attachment is adopted it becomes imperative to calculate the additional moments, and for this purpose the following extension of Claxton Fidler's method is suggested as effecting that object with a minimum of time and labour. Analytical determinations can be used, but they will be found to be long and tedious.

The forces in each wire can be looked upon as the resultant of two components, one vertical, the sum of which

for all the wires is approximately equal to the total load on the spar but the exact magnitude of which is influenced by the shape and area of the diagram of bending moments, the other along a line joining the point of attachment to the point where the neutral axis of the spar cuts the fuselage of the machine. These second components produce bending moments which vary uniformly in magnitude from $Pd \cos \theta$ at the point of attachment to zero at the fuselage. The diagram of bending moment caused thereby on any span is thus of trapezium or triangular form.

Let *Fig. 3a* represent a spar of this type and let $P_1P_2P_3$ represent the forces induced in the wires attached to the spar at points *FGH* respectively. These points lying at a distance d below the neutral axis. If P_1 be resolved along a line perpendicular to *BE* and along a line *FE*, then the perpendicular component of P_1 will represent the vertical reaction at the point *B*. The force along *FE* will induce moments in the spar which will vary in magnitude uniformly from *B* to *E* being zero at this latter point. Similarly P_2 and P_3 will produce vertical reactions at *C* and *D* respectively and induce moments which vary uniformly from *C* to *E* and from *D* to *E* respectively, being zero at this latter point.

The bending moment diagram caused by these approximately horizontal components will be as shown in *Fig. 4*, but this diagram cannot yet be accurately drawn, since $P_1P_2P_3$ are still unknown.

In order to find the magnitudes of $P_1P_2P_3$ and so enable the bending moment diagram for the approximately horizontal components to be drawn, it is necessary to make certain approximations, which are, however, usually so close to the truth as to render them well within the limit of error allowable on work of this des-

cription. Produce $P_1P_2P_3$ to cut the neutral axis of the spar in points m, n, o respectively. Since FB, CG and DH are in practice always small, the distance mB by which m lies to the left of B will also be small. If now we consider the forces $P_1P_2P_3$ to be acting at m, n , and o , the spar will be under the same loadings and moments as before, except that there will now be excess moments equal to the moments produced by the approximately horizontal components of $P_1P_2P_3$ acting at B, C, D respectively and varying uniformly from B to m , from C to n , and from D to o respectively, being zero at m, n , and o . The areas of the excess moment diagrams are small, and therefore for a first approximation they may be neglected. Also, since the slope of the beams will be small for a certain distance at either side of any prop, it follows that the three points m, n , and o will lie sensibly in a straight line. The slope of the spar at these points will therefore be given by the distance by which the base line passes over or under characteristic points on either side of the prop, and the heights of these characteristic points will be given by two-thirds the maximum height of the parabolas on the equivalent spans mn, no, oE respectively.

The bending moment diagram, *Fig. 5*, for this modified system may be drawn according to the methods already indicated. It may be noted here that although they have been sketched in the figure for the sake of clearness, it is unnecessary to draw the actual parabolas for the detached spans since it is only required to know the maximum heights in order to determine the characteristic points. Let M_m, M_n, M_o be the moments at m, n , and o as obtained from this diagram. Take now the portion of the spar lying to the left of n and write down the bending moment at n in terms of the distributed load and P_1 . This value if equated to the moment at n as

found from the above diagram will give an equation from which P_1 may be determined. Similarly by equating moments of forces to the left of o to the moment at o as found from the diagram P_2 may be deduced, and finally P_3 may be obtained since the moment at E is zero. These values of P_1, P_2, P_3 will be very close approximations to their true values. The bending moment diagram for the loading as actually applied may now be drawn. At B (*Fig. 6*) set up a perpendicular equal in length to $P_1 d \cos \alpha$ and join the extremity of this to the point E at the end of the spar. At C add to the ordinate at that point a length mn equal to $P_2 d \cos \beta$ and join its extremity to E . At D add to the total ordinate at that point a length op equal to $P_3 d \cos \delta$ and again join to E . This diagram will represent with considerable accuracy the diagram of bending moments actually induced by the approximately horizontal components of the true pulls in the wires. Using the upper lines of this diagram as bases, draw parabolas to represent the bending moment diagrams for the spans simply supported at B, C, D, E . It is necessary now to determine the position of the characteristic points for figures of shape such as these which consist of a parabola superposed upon a trapezium or triangle. The best method is to consider separately the component elementary figures, viz., rectangles, parabolas, and triangles which constitute the complete diagram.

If B be the breadth of the rectangular diagram and L the span under consideration, the height of the characteristic point above the horizontal base line will be

$$\frac{2 \Delta x}{L^2}$$

which reduces to B and it is therefore apparent that these points lie upon the upper line of the rectangle (*Fig. 7a*). In the case of a triangle of maximum height at

one end equal to B , the expression for the characteristic point which lies on the side of the maximum ordinate of the triangle, becomes equal to $\frac{2B}{3}$, so that the point lies on the upper line of the triangle. Similarly the length of the perpendicular for the other characteristic point of the span becomes $\frac{1}{3B}$, and the point is again upon the upper line (*Fig. 7b*). Since a trapezium can always be divided into a rectangle and a triangle and since the heights of the characteristic points above the horizontal base are additive, it follows that these points will lie upon the upper line of the trapezium if the bending moment diagram be of that shape (*Fig. 7c*). If then the free ended bending moment diagram for any span consist of a parabola superposed upon a trapezium the characteristic points will lie at distances above the base line equal to the height to the upper line of the trapezium at that point, added to two-thirds the maximum vertical ordinate of the parabola, *i.e.*,

$$\frac{2}{3} \text{ of } \frac{wl^2}{8},$$

l being the length of span under consideration. The characteristic points having been determined it only remains to draw a base line which gives a moment at B equal to the cantilever moment, passes over and under each characteristic point on either side of a support by equal amounts and finally gives a zero value at the fuselage. Next check the values of P_1, P_2, P_3 by equating the bending moment at a point immediately to the left of each support to the moments caused by the uniform loading and the load in the wires. Should any serious discrepancy be apparent, the diagram may be modified in the light of our more complete knowledge, but in practice this is rarely if ever necessary.

The process of finding the bending moments on an aeroplane spar with non-axial attachments may therefore be summarised as follows:—

1°. Divide the length into spans equal to the distance between the intersections of the wires with the axis of the spar.

2°. Draw Claxton Fidler's bending moment diagram for this arrangement.

3°. Taking the moments thus found for these imaginary points of support, calculate the pull on the wires by equating the moments of external loads and forces on the wires to these values.

4°. Returning now to the actual spar, draw the diagram of bending moments induced by the components of the pulls in the wires in a direction parallel to the lines joining the actual points of attachment to the fuselage end of the spar.

5°. Set up parabolas representing the moments upon supported beams of spans equal to the distance between the attachments, these parabolas being drawn from the upper lines of the diagram in section 4 as base.

6°. Find the characteristic points of this diagram and draw the true base line.

In order to render the method clear the example previously taken for a spar loaded with 40 lbs. per foot run and supported at three equidistant points 4' 6" apart has been worked out, on the assumption that the points of attachment of the wires lie two inches below the neutral axis of the beam, the other end of the wires being attached to a point 4' 8" below the end of the spar where attached to the fuselage.

If P_1, P_2, P_3 be produced as described, we obtain three spans of 4' 8" each, together with a cantilever portion of

1' 9". The maximum height of the parabolic free ended bending moment diagrams is equal to

$$\frac{wl^2}{8} = \frac{40 \times 4.67^2}{8} = 109 \text{ ft. lbs.}$$

The maximum bending moment on the cantilever portion will amount to

$$\frac{wl^2}{2} = \frac{40 \times 1.75^2}{2} = 61.3 \text{ ft. lbs.}$$

The characteristic points are shown in *s, t, u, v* (Fig. 5), their heights above the free ended base line being obtained by joining the extremity of the maximum ordinate of the parabola to the points at the extremities of each span, the point where the vertical at one-third and two-thirds the span cuts this line, being the characteristic point for the nearer support. The true base line *p, q, r, E* has been drawn so that *sl=at* and *ub=vc*. From this diagram the moments at the equivalent points of support are scaled off as 70 ft. lbs. at *n* and 92 ft. lbs. at *o*. We have therefore, taking moments round *n* (see Fig. 3*b*),

$$P_1 \times 1.47 = \frac{40 \times 6.42^2}{2} - 70$$

$$P_1 = 514 \text{ lbs.}$$

Taking moments round *o*,

$$P_2 \times 2.09 + P_1 \times 2.96 = \frac{40 \times 11.08^2}{2} - 92$$

$$P_2 = 404 \text{ lbs.}$$

Taking the moments round *E*,

$$P_3 \times 3.30 + P_1 \times 4.44 + P_2 \times 4.17 = \frac{40 \times 15.75^2}{2}$$

$$P_3 = 304 \text{ lbs.}$$

The horizontal component of $P_1=488$ lbs., and therefore the moment it induces at *B* = 81.4 lbs. Similarly the moments induced by P_2 and P_3 at *C* and *D* will be 60.4 ft. lbs. and 36.0 ft. lbs. respectively.

These values may be used as already indicated (*Fig. 6*) to draw the moment diagram $Blmno pE$ for the approximately horizontal components of $P_1P_2P_3$.

Now, at the centres of lm , no and pE (*Fig. 6*) set up ordinates equal to

$$\frac{wl^2}{8} = \frac{40 \times 4.5^2}{8} = 101 \text{ ft. lbs.}$$

and determine the characteristic points h, i, j, k . These have been shown to lie above the lines lm , no and pE at distances of $\frac{2}{3}$ the maximum parabolic ordinate.

The moment of the left hand side of B is equal to that induced by the cantilever, and amounts therefore to 101 ft. lbs. The true base line $ur st E$ can now be drawn as before described.

Next, check the values of $P_1P_2P_3$ by taking moments about points immediately to the left of C and D respectively.

The moment at a point immediately to the left of C is scaled as 99 ft. lbs.

$$\therefore P_1 \times 1.59 = \frac{40 \times 6.75^2}{2} - 99.$$

$$\therefore P_1 = 511 \text{ lbs.}$$

The moment immediately to the left of D is scaled as 110 ft. lbs.

$$\therefore P_2 \times 2.16 + P_1 \times 3.02 = \frac{40 \times 11.25^2}{2} - 110.$$

$$P_2 = 407 \text{ lbs.}$$

Taking moments round E

$$P_3 \times 3.30 + P_2 \times 4.17 + P_1 \times 4.44 = \frac{40 \times 15.75^2}{2}$$

$$P_3 = 304 \text{ lbs.}$$

Comparing these with the values obtained from the equivalent diagram (*Fig. 5*), it will be seen that the agreement is very satisfactory.

By inspection of the complete diagram the justification of our statement that by producing the supporting wires to cut the neutral axis, and considering this as equivalent to the original system so far as reactions were concerned, it is more apparent. Although the neglected moments are large in magnitude, they only extend over very short lengths of the beam, and so their effect on the reactions, which is due to the moments of area of their diagrams, is small, thus the portion neglected at C is shown approximately by the triangular diagram $n m x$ (*Fig. 6*) and in comparison with the area of the diagram caused by the approximately horizontal components of the force in the wire is of small account when finding reactions. The excess moments involved at the supports are of course extremely important in themselves, since they increase and decrease rapidly. From the diagram it is also apparent how by attaching the wires even a short distance below the neutral axis, large bending moments are set up. In the case outlined above, which is representative of ordinary practice, the moment at C is increased from 55 ft. lbs. when the wires are attached centrally (*Figs. 1 and 2*) to 99 ft. lbs. when the eccentricity amounts only to 2 ins., or in other words the moment at C is increased by 80 per cent.

In a number of monoplane the maximum bending moment occurs at B owing to the length of the cantilever portion. It does not follow, however, that the maximum stress will occur at this point since the greatest direct compressive force in the spar is that induced in the inward spar, and the total stress is that due to the combined action of the bending moment and the direct compression. In the design of a spar, however, it is advisable to bear in mind that a large overhang at the outer end will usually increase the maximum bending

moment. If, on the other hand, the outer wire be attached at a point nearer to the wing tip, the bending moment at *B* is lessened, but the direct force in the spar is increased, and it may well happen that this compression may be increased to an inconvenient degree.

In determining the strength of a spar it is necessary to consider the stresses which may be induced under abnormal conditions, in addition to those which obtain when everything is perfectly adjusted. These abnormal conditions may be brought about by the elastic or accidental stretching of a wire, or even by the breakage of one or more wires. In the latter case, the above method of computing the bending moments may be used directly and it may be found possible to arrange for factors of safety high enough to obviate accident even under these abnormal conditions. The most likely event, however, to occur, is the stretching or misadjustment of a wire and the consequent elevation of one of the points of attachment above the line of the others. Claxton Fidler has shown how this may be dealt with for the simple continuous beam by modifying the heights of the characteristic points above the free ended base line. These heights should be increased or decreased by a given distance according as the prop to which they refer has risen above or sunk beneath the line of the other props. A modification of the characteristic points for the props lying on either side of the sunken prop is also necessary, this modification being in the opposite direction and equal to half that of the sunken prop. This, however, is discussed at length in Claxton Fidler's "Treatise on Bridge Construction," to which the reader is referred. The extension suggested above for cases where the wires are attached at points lying away from the neutral axis can however be applied equally well to the case of the sunken prop, and

the effect of an arbitrary movement of each support can therefore be quickly investigated.

Moments due to the endlong loadings acting through distances equal to the deflections of the spar from its initial position.

These moments usually become of importance if the wires be badly adjusted or injured in such a way as to cause the points of attachment to lie other than in one straight line. An extreme case is of course presented if one of the inner wires happens to break during the flight of the machine. They may be estimated by drawing the deflection curve for the spar under its uniform and bracing wire moments, this deflection curve being the funicular polygon of the bending moment curve. The horizontal components of the pulls in the wires, viz., $\Sigma Pd \cos \theta$, when multiplied by the deflections as given by the curve will give a reasonable approximation to the additional bending moments, which may be added to those already found.

For a full development of this method the reader is referred to a paper on Struts and Ties under lateral and non-axial loads.²

Conclusion.

It will be seen that in many cases the exact determination of the stresses in a spar is exceedingly complex. The most serious point likely to be overlooked in practice is the moment due to the points of attachment not lying on the neutral axis. The spar is rendered stronger and the calculations simplified by arranging for the wires to be connected in the correct position, but where this cannot be done the graphical method given above renders the determination of the additional stresses easily and quickly determinable.

² "Struts and Ties under lateral and non-axial loads." C. H. Lander, *Phil. Mag.*, Jan., 1914.



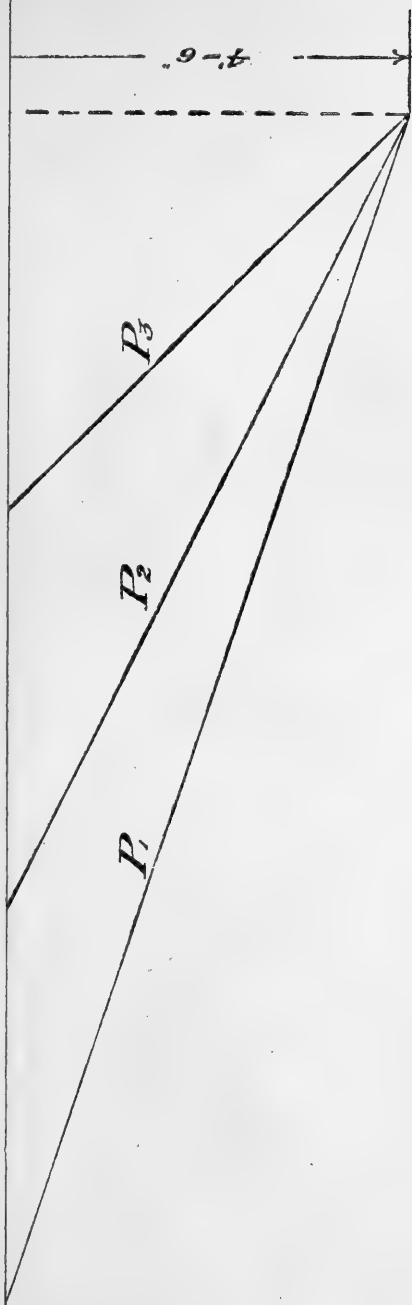

Fig. 1.

Aeroplane spar with wires attached at neutral axis.



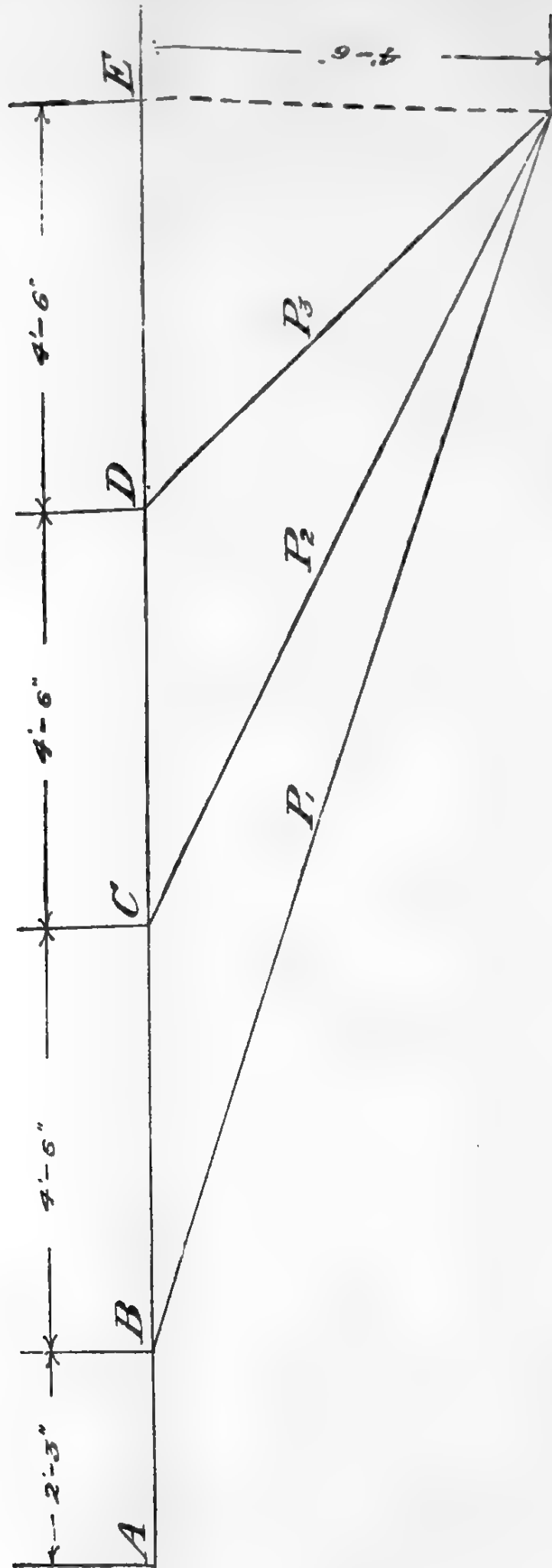

Fig. 1.

Aeroplane spar with wires attached at neutral axis.



100 150 200 Ft Lbs

Bending Moments

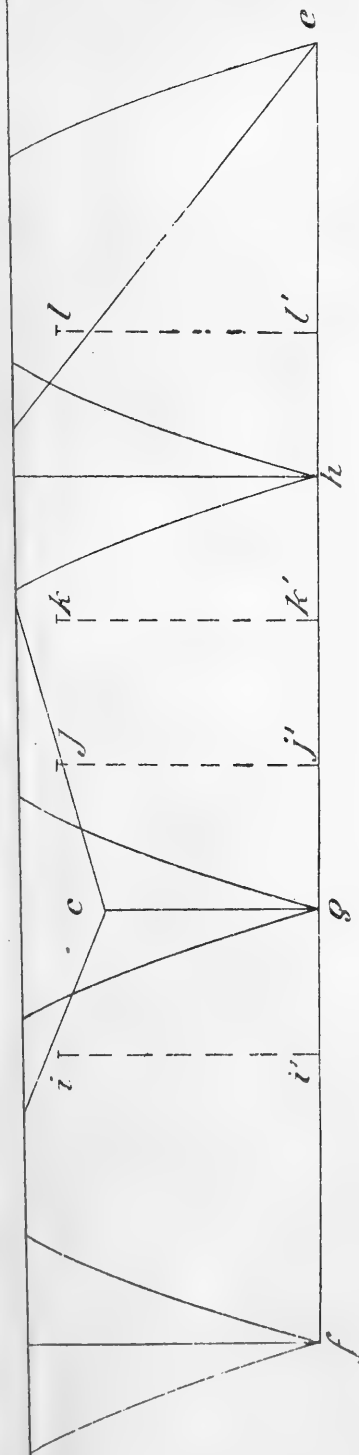
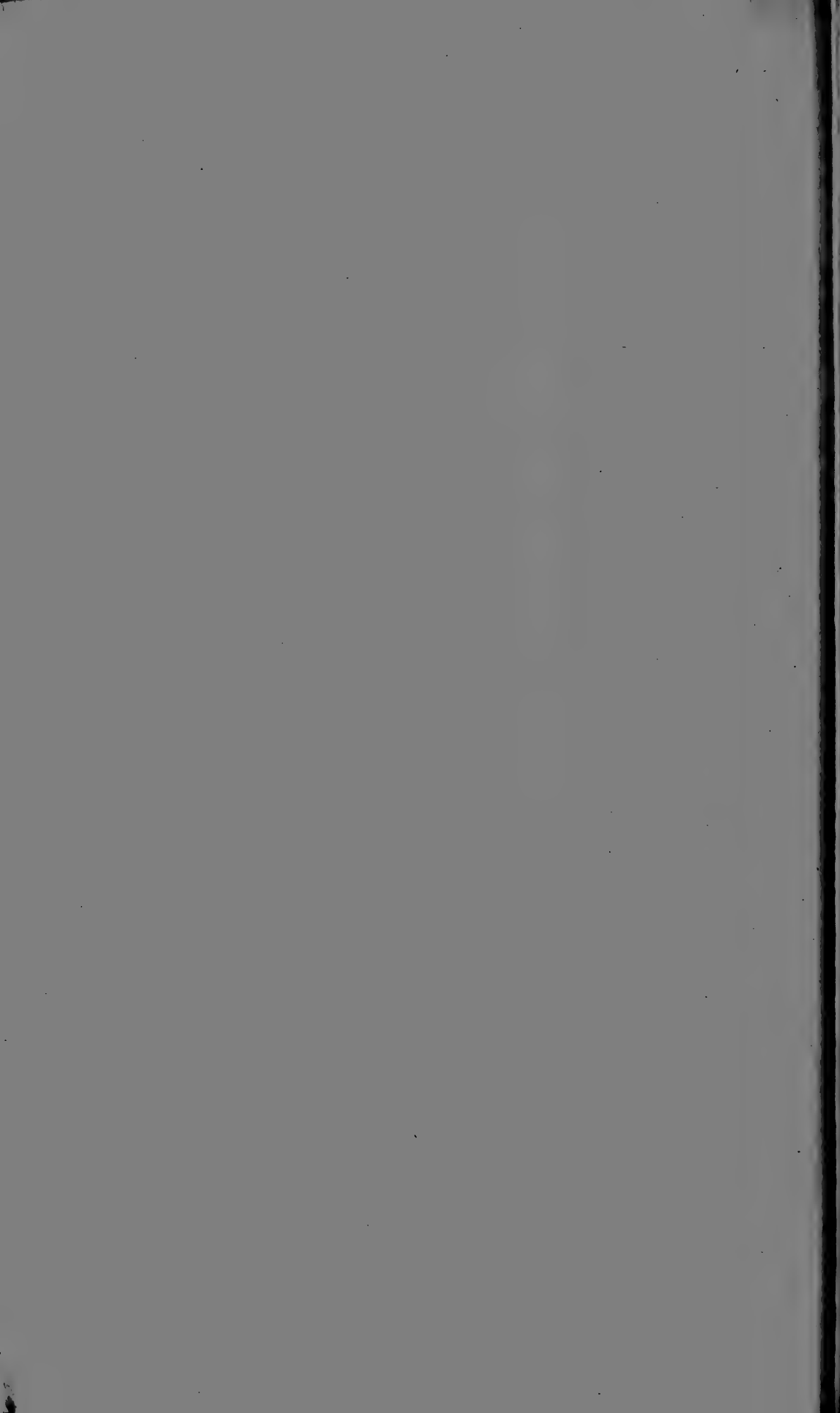

Fig. 2.
Bending moment diagram for aeroplane spar with wires attached at neutral axis.



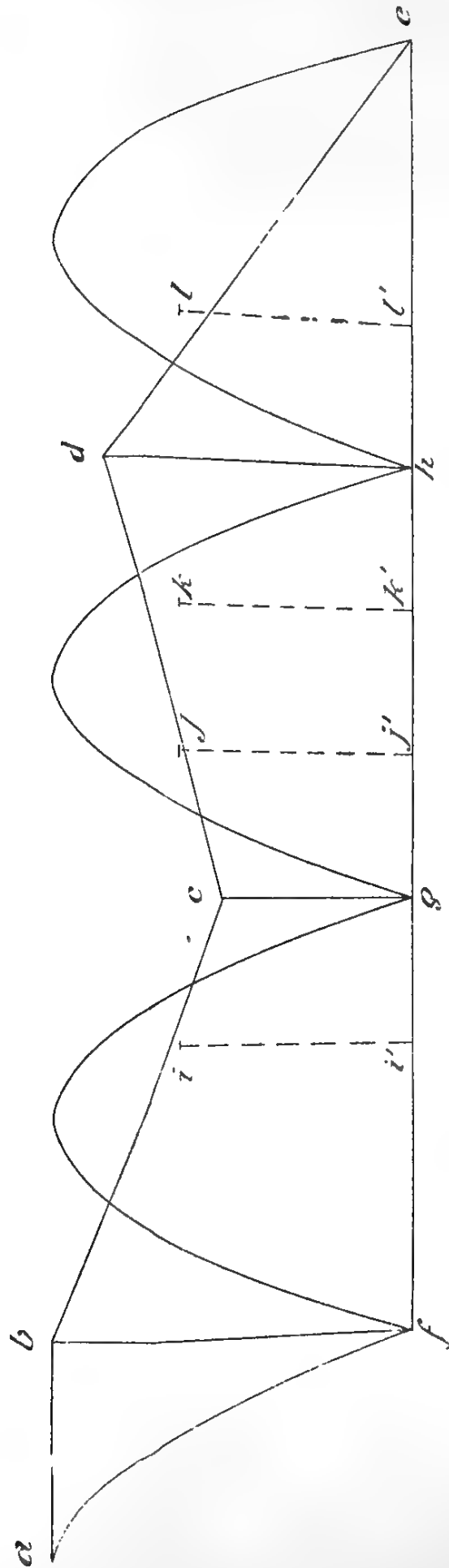
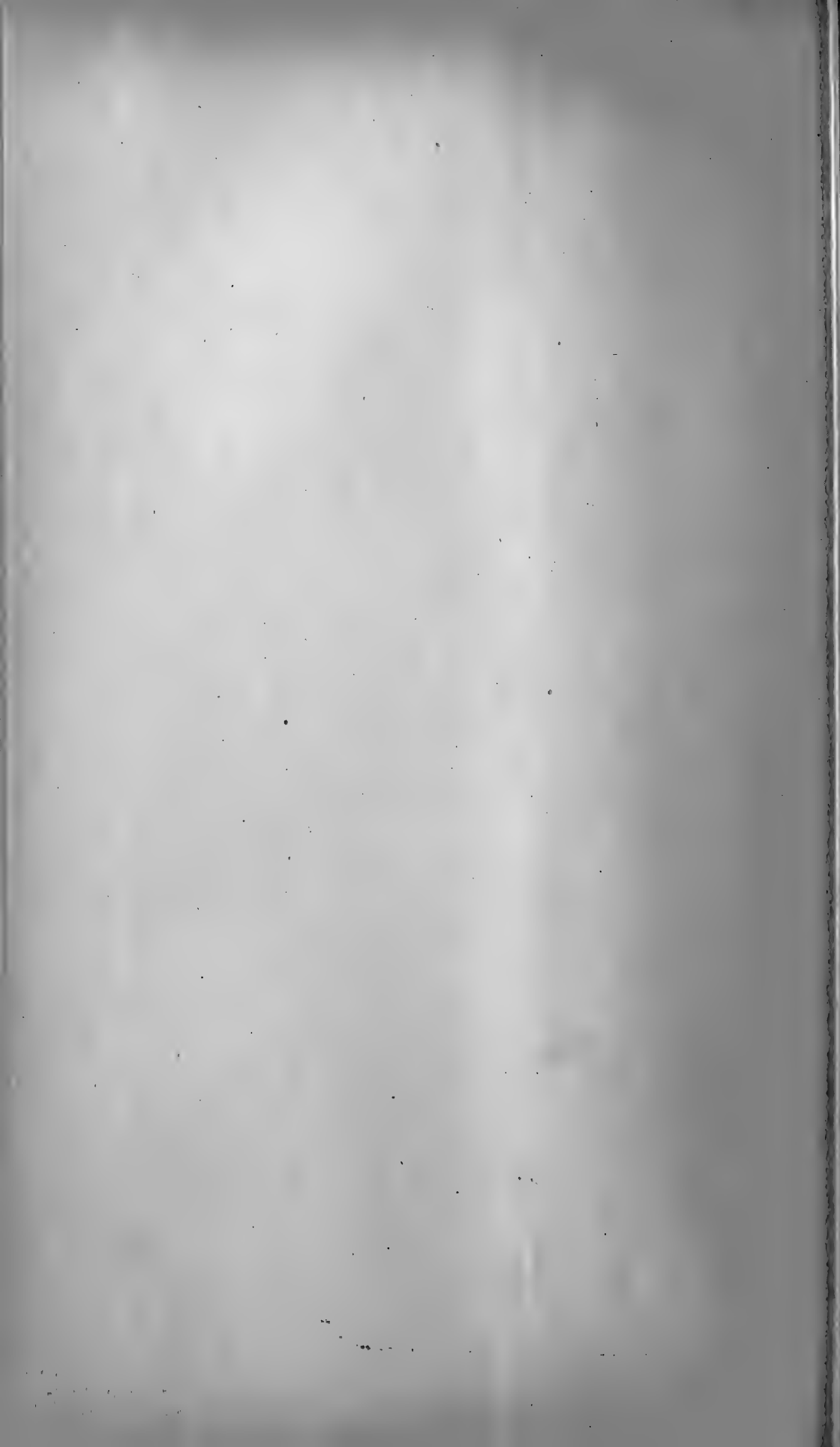

Fig. 2.
Bending moment diagram for aeroplane spar with wires attached at neutral axis.



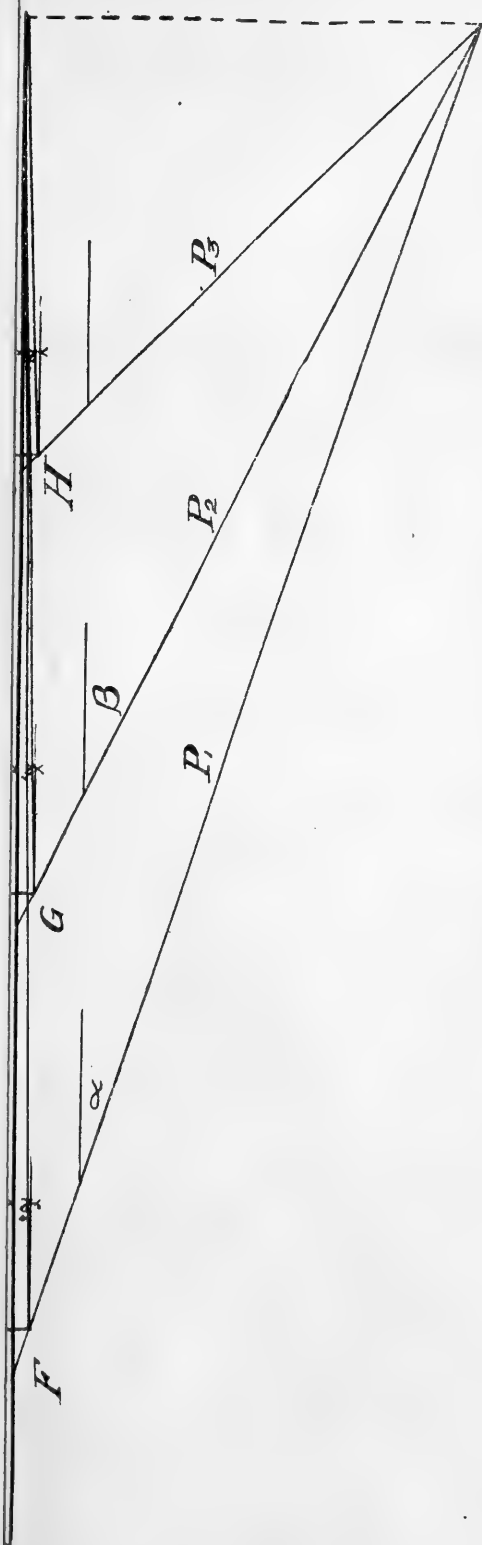

Fig. 3a.

Aeroplane spar with wires attached away from neutral axis.



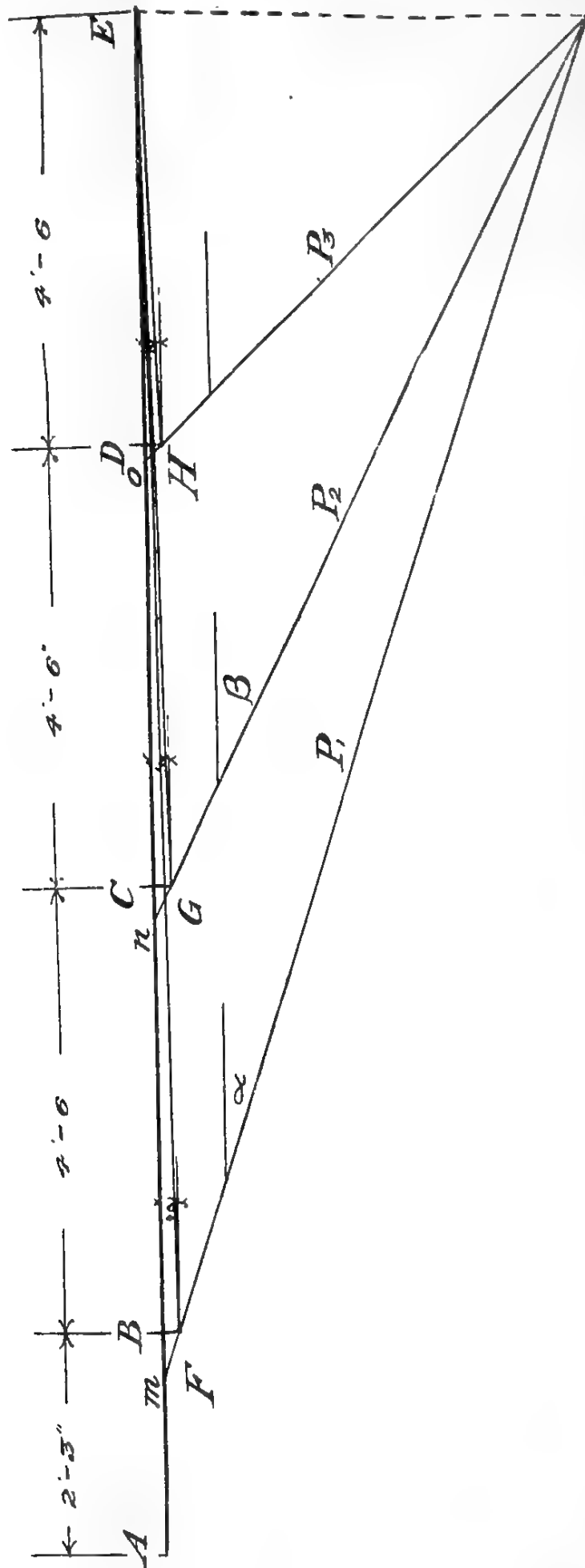

Fig. 3a.
Aeroplane spar with wires attached away from neutral axis.



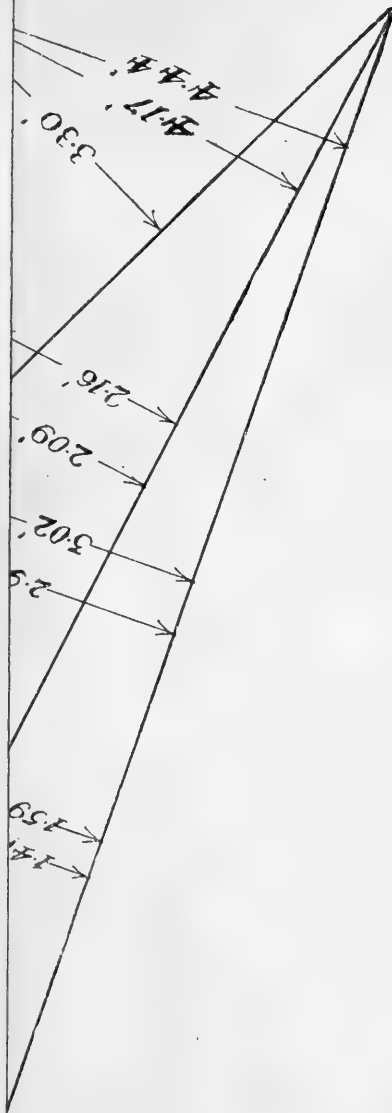

Fig. 3b.
Giving dimensions for use in calculations.



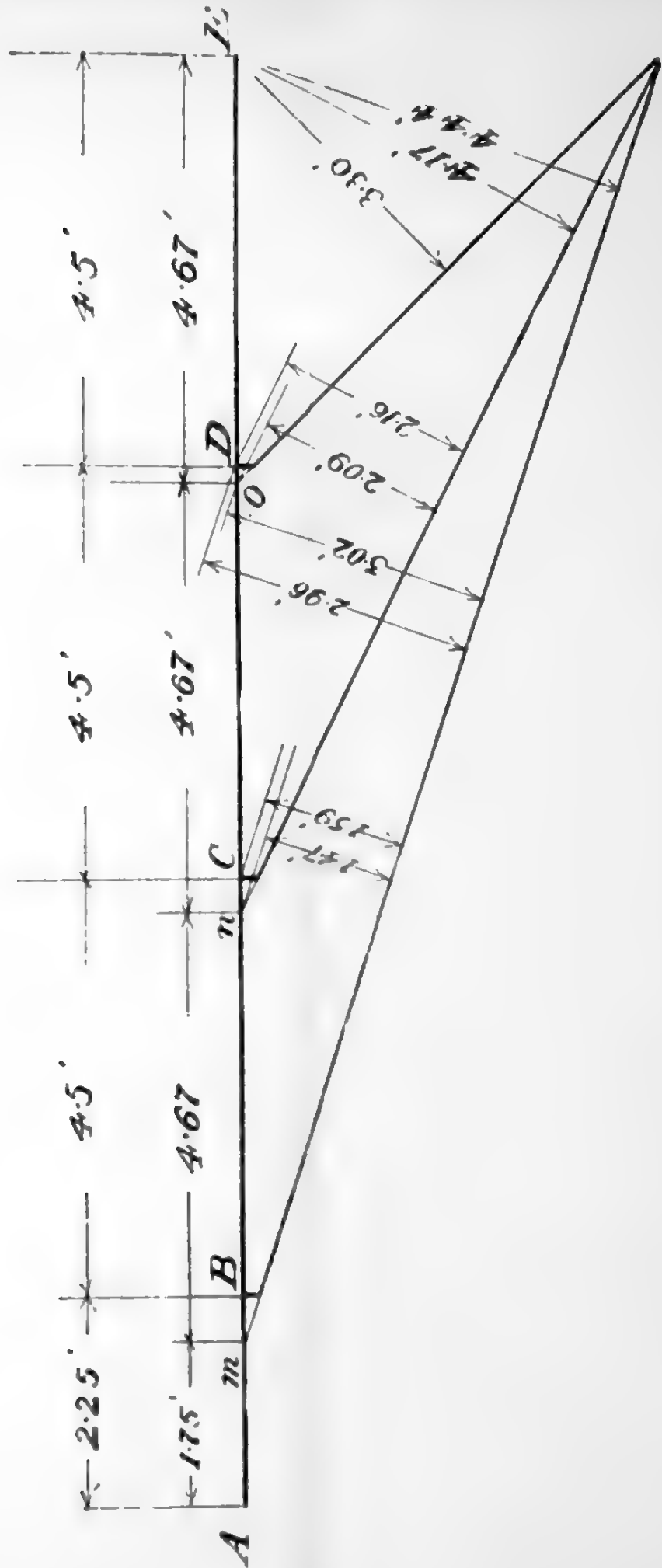
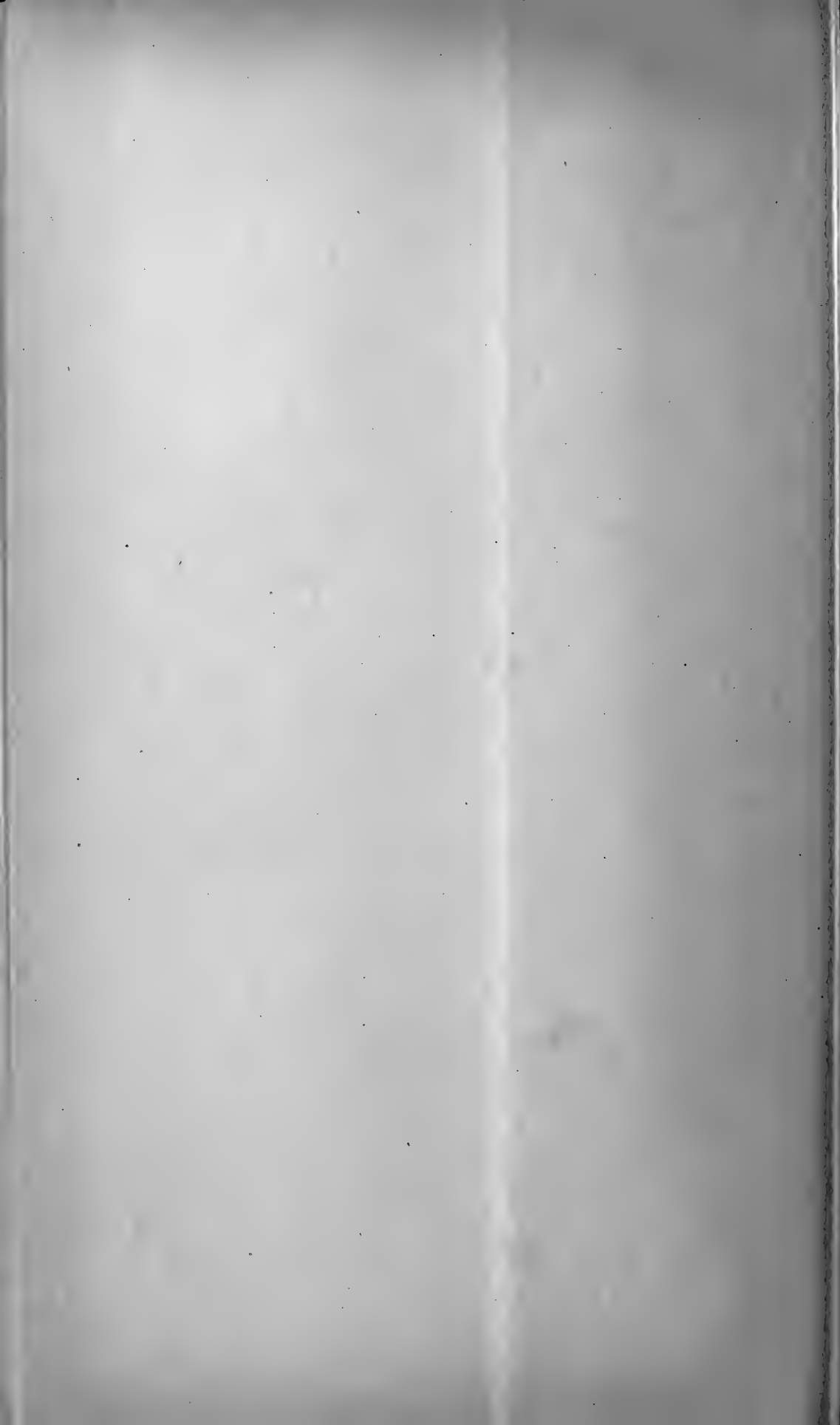

Fig. 36.
Giving dimensions for use in calculations.



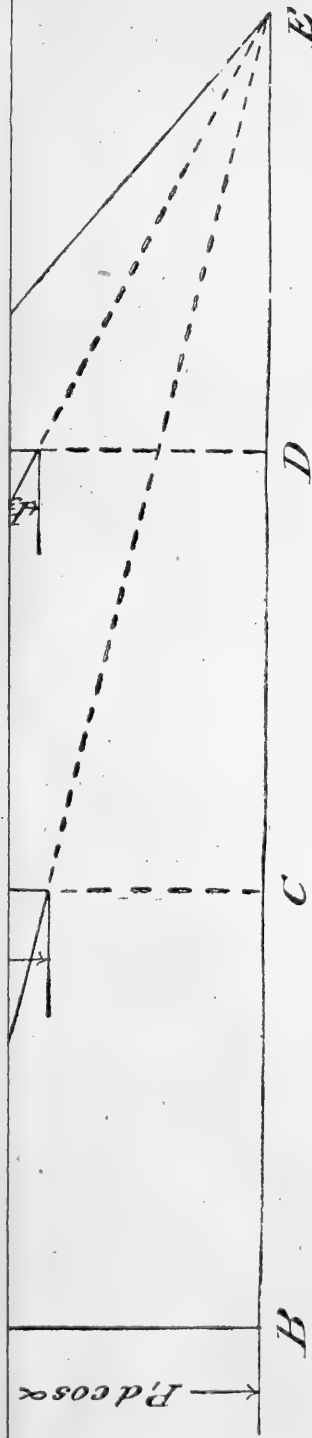

Fig. 4.

Bending moment diagram for horizontal components of P_1 , P_2 , P_3 .





100 150 200 Ft. Lbs.

Bending Moments

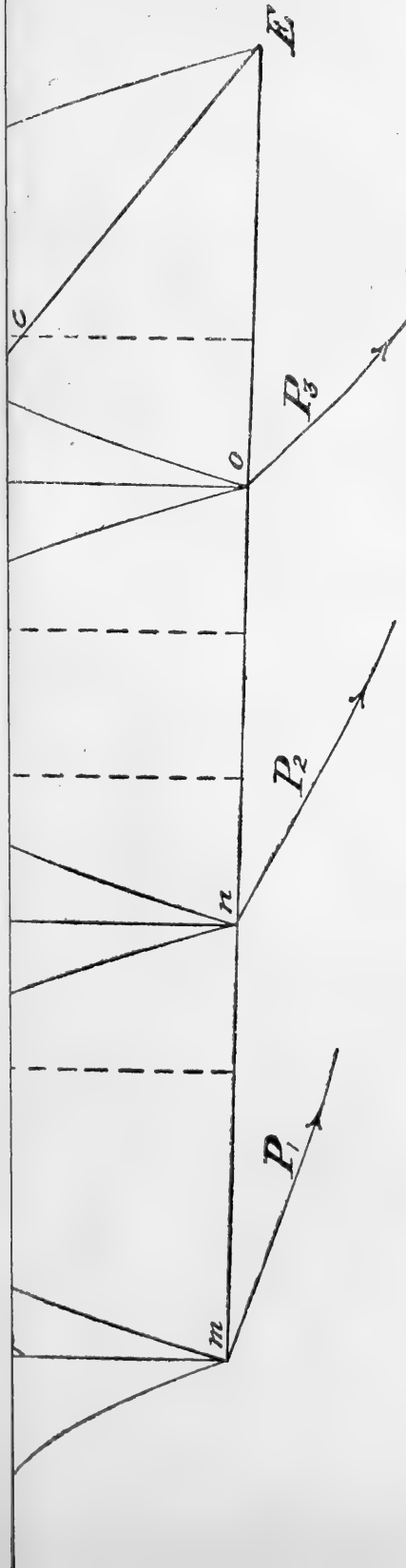
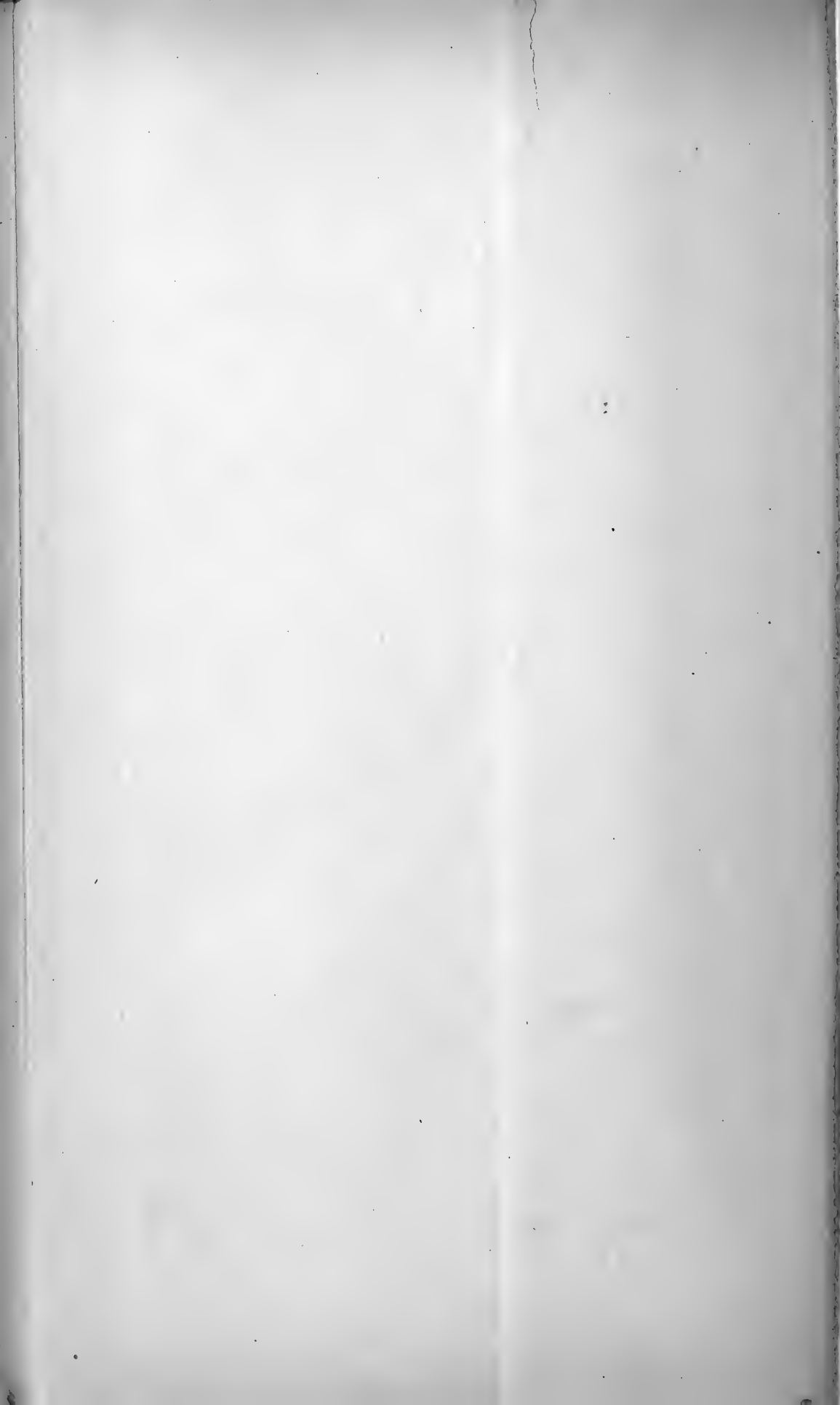

Fig. 5.

Bending moment diagram for spar with substituted spans.



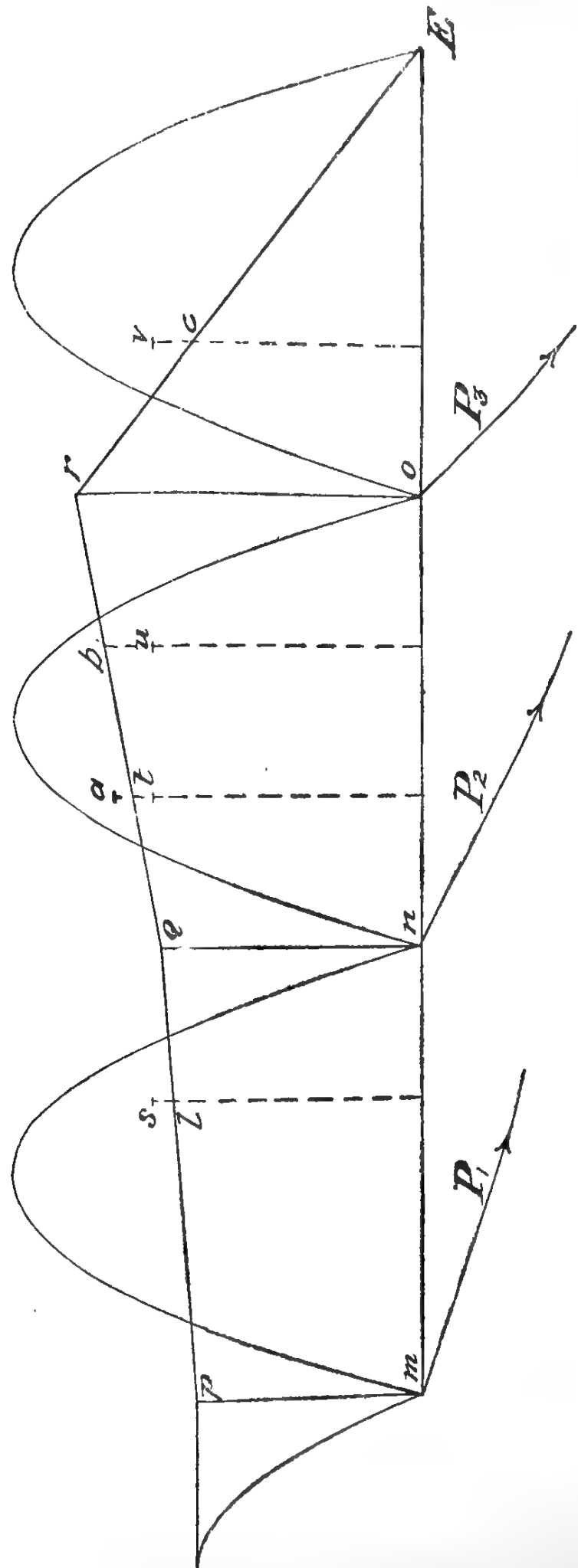
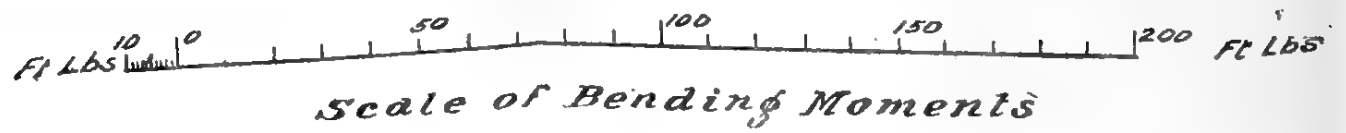
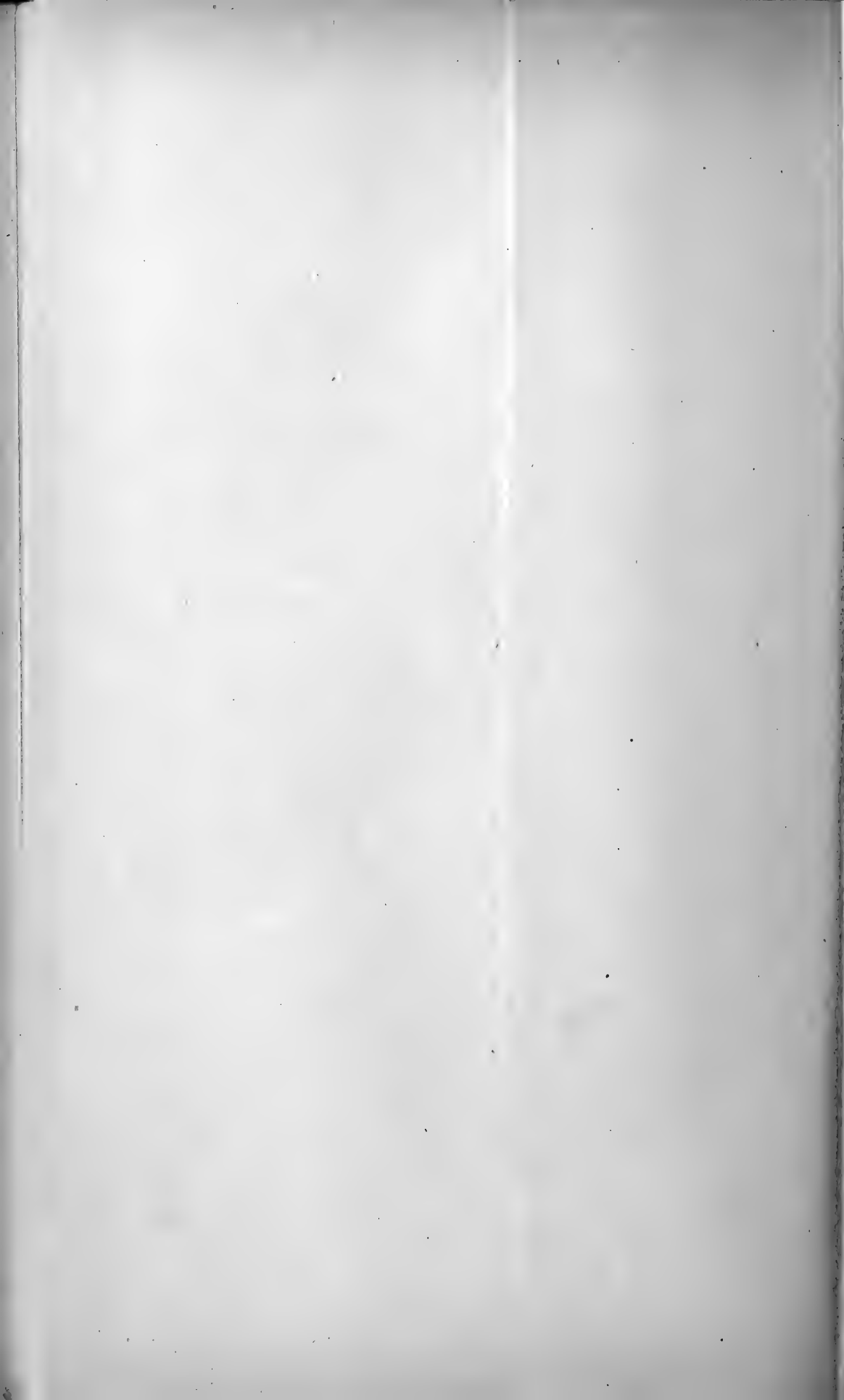

Fig. 5.
Bending moment diagram for spar with substituted spans.



100 150 200 Ft Lbs
Bending Moments

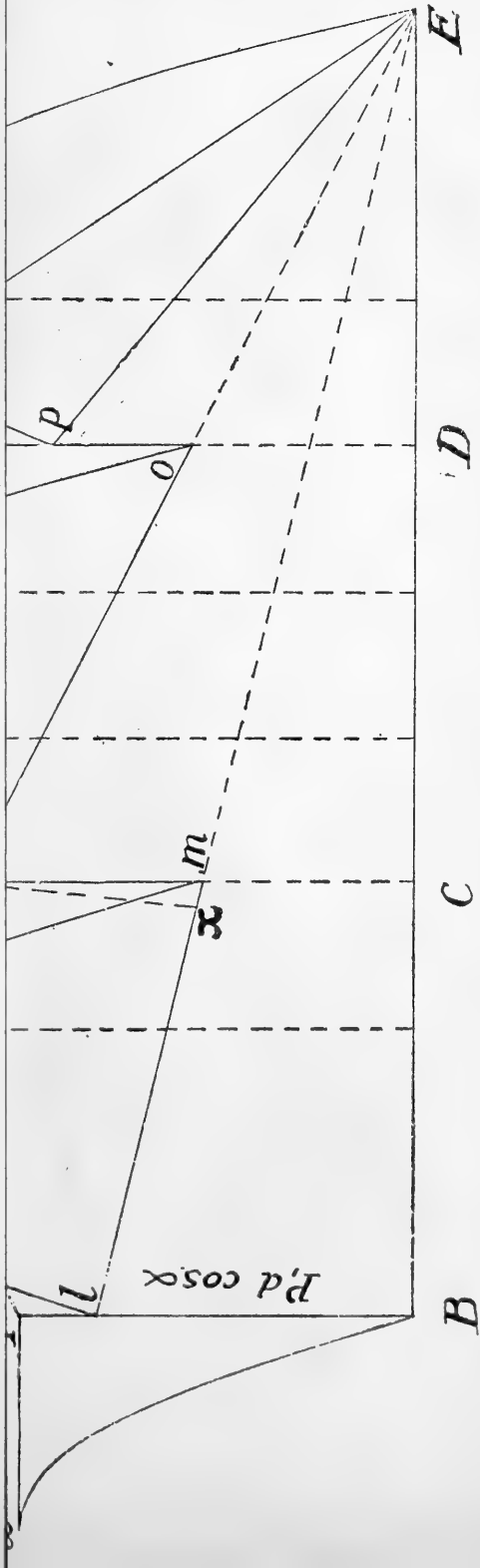

Fig. 6.
Construction of final bending moment diagram.



FT LBS ¹⁰ 0 50 100 150 200 Ft Lbs

Scale of Bending Moments

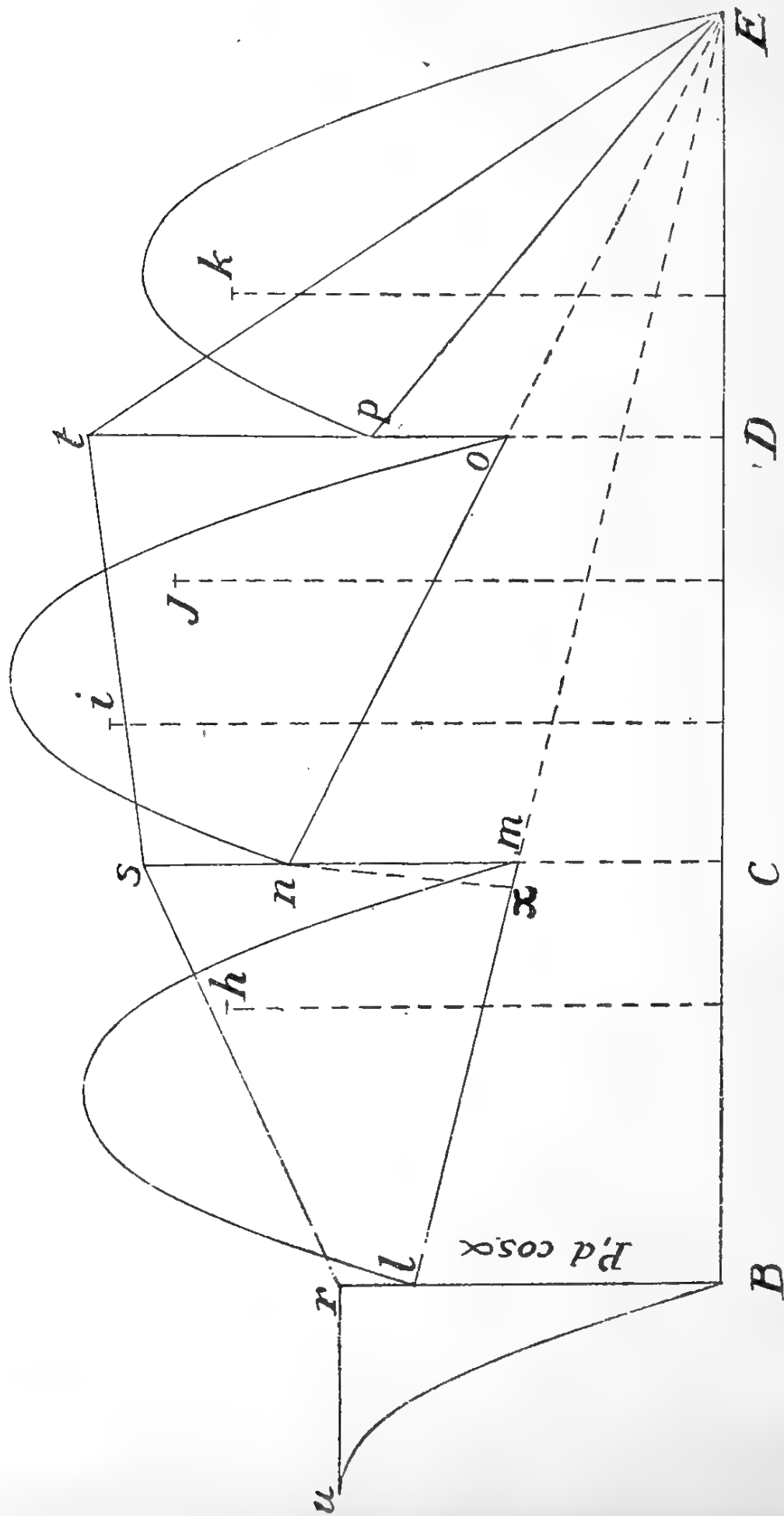
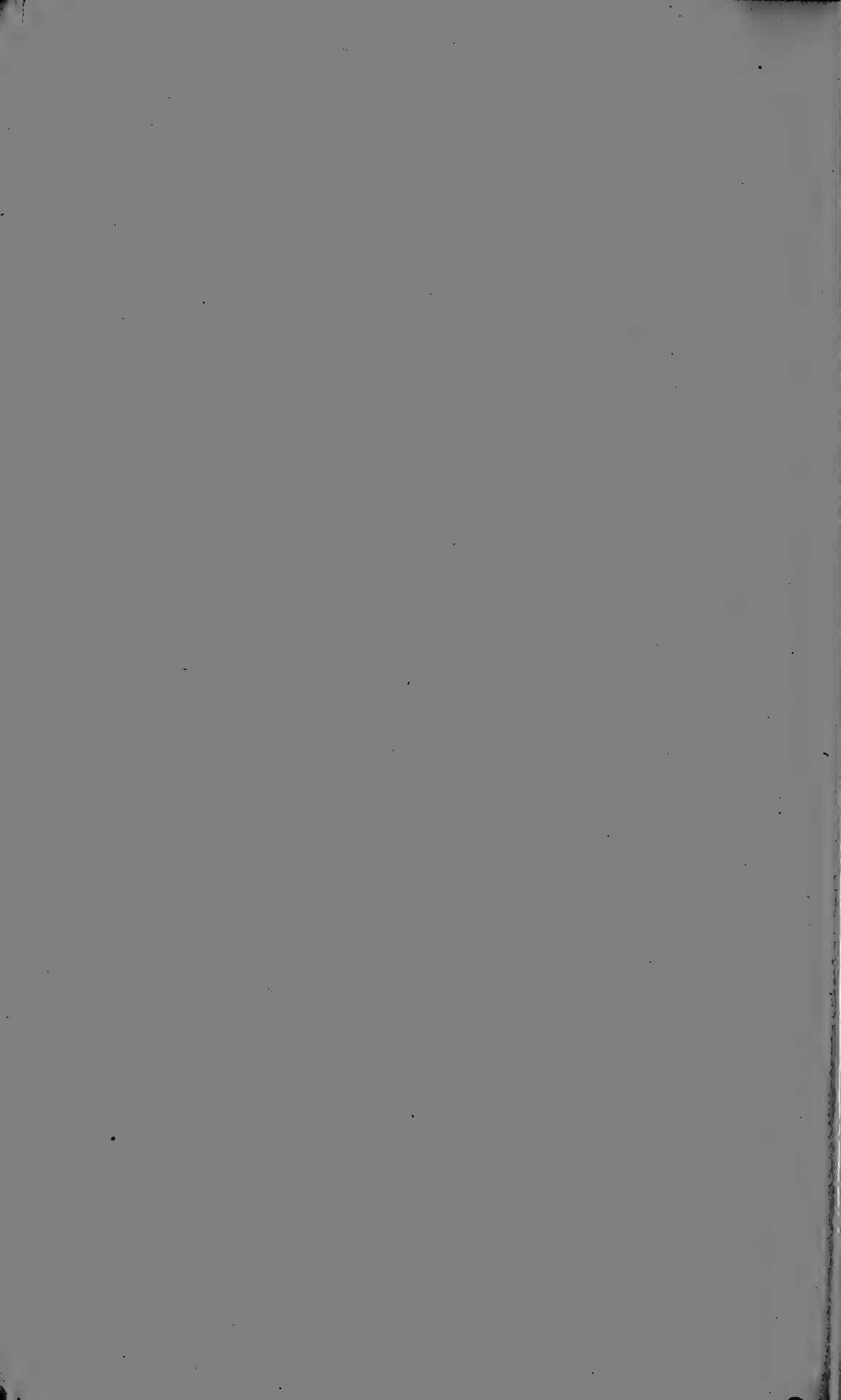

Fig. 6.
Construction of final bending moment diagram.



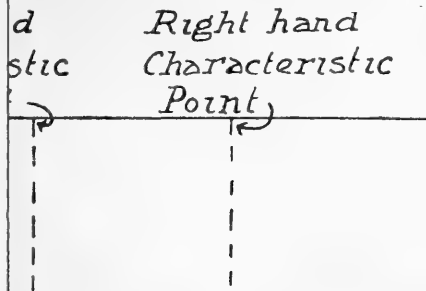

Fig. 7a.

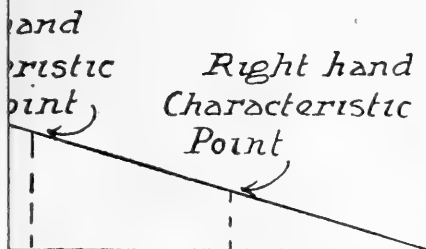
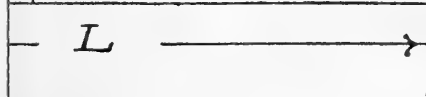

Fig. 7b.

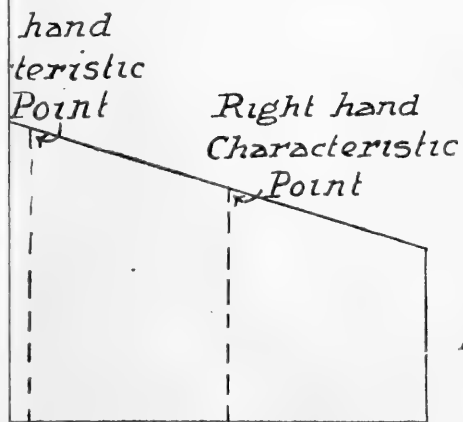
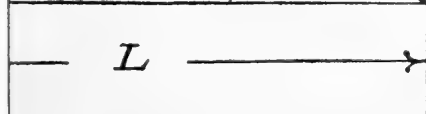

Fig. 7c.

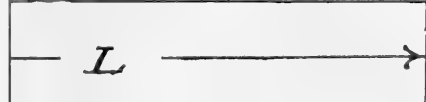
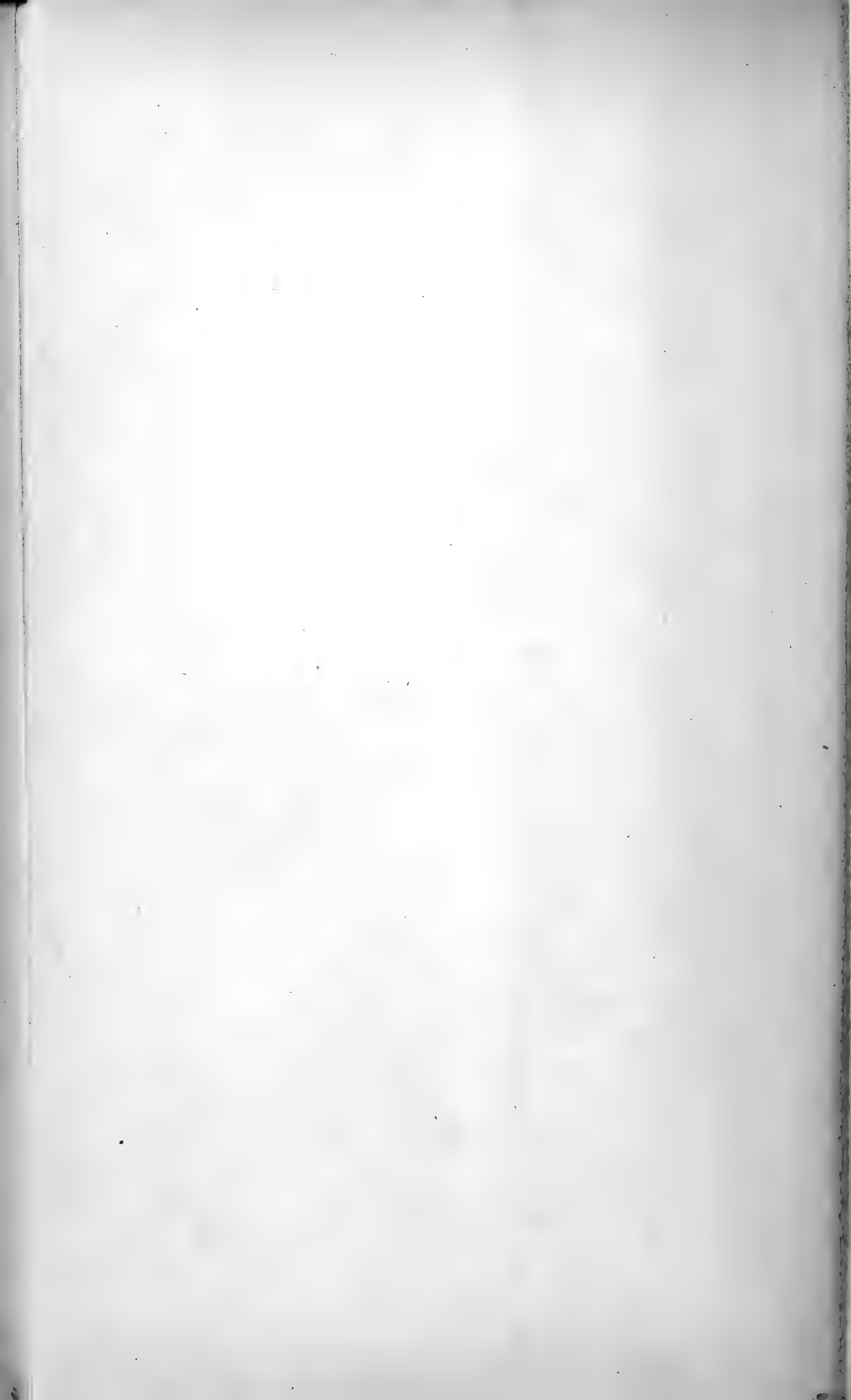

Fig. 7.



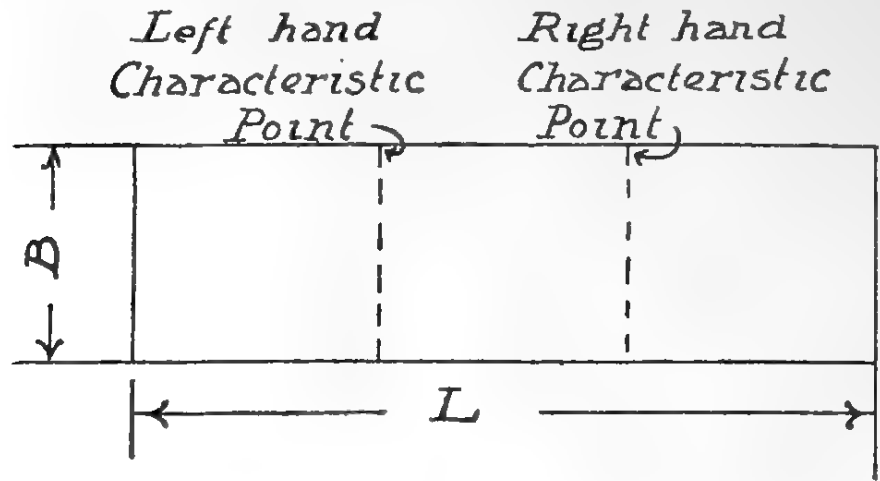

Fig. 7a

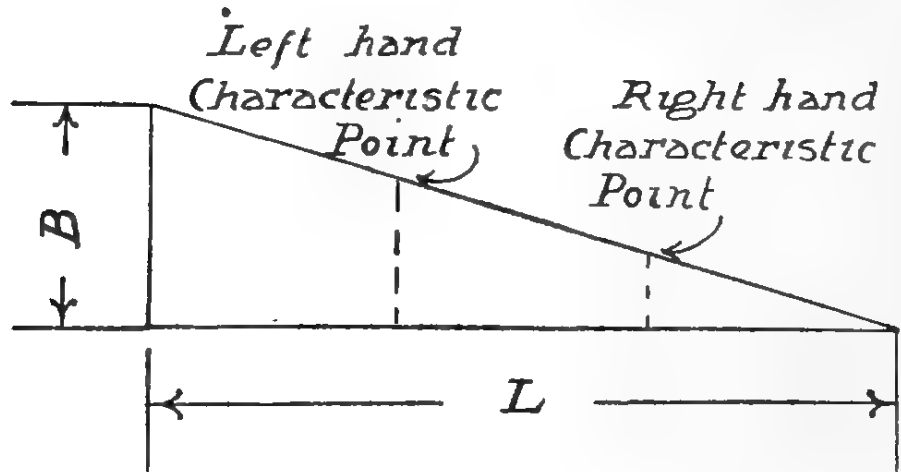

Fig. 7b.

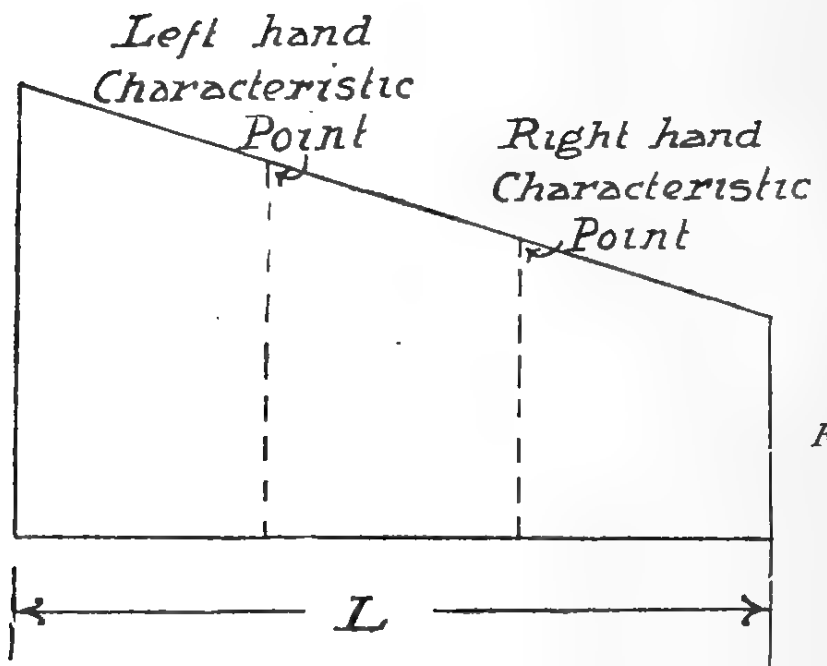
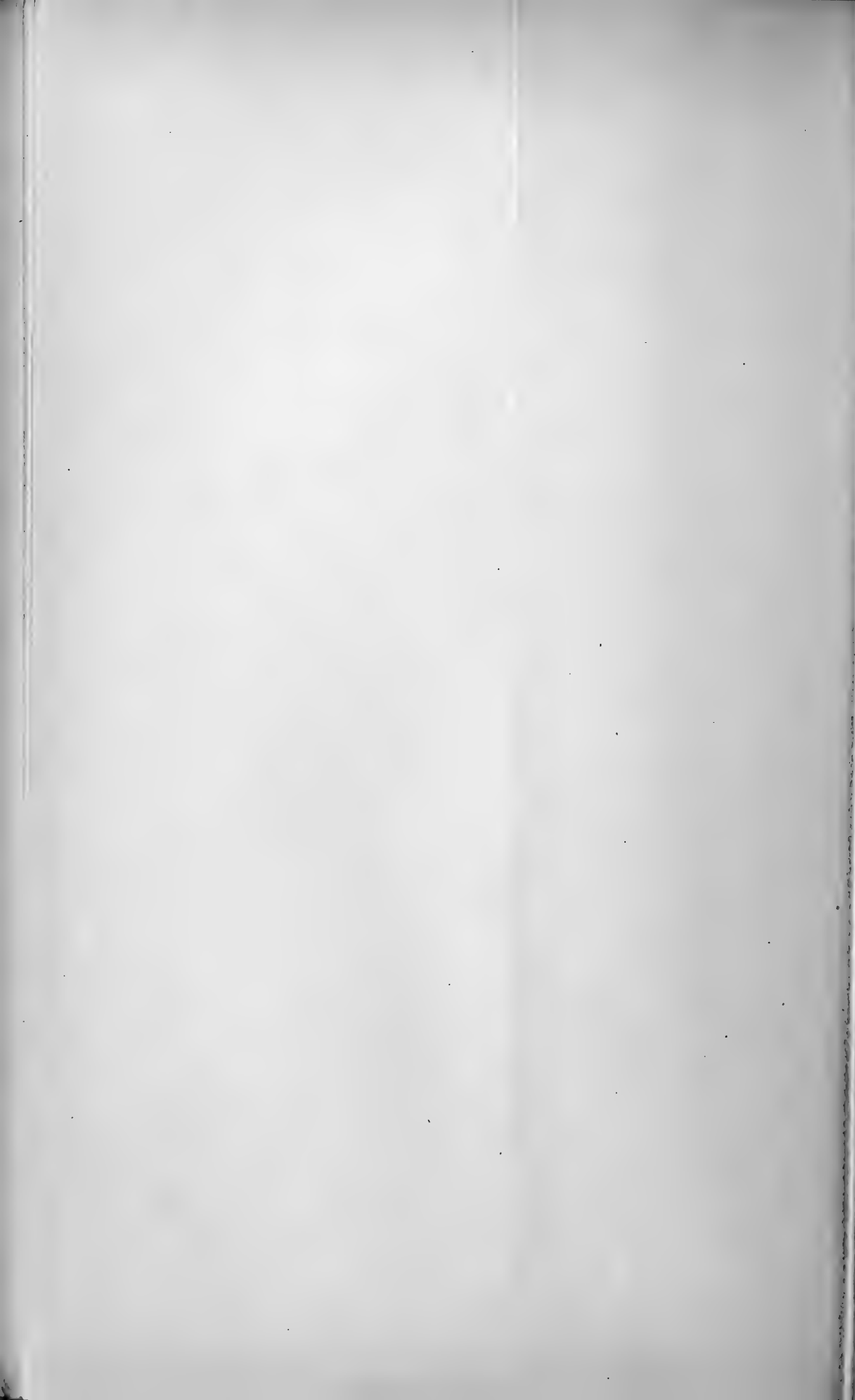

Fig. 7c.

Fig. 7.



100 150 200 Ft Lbs
Bending Moments

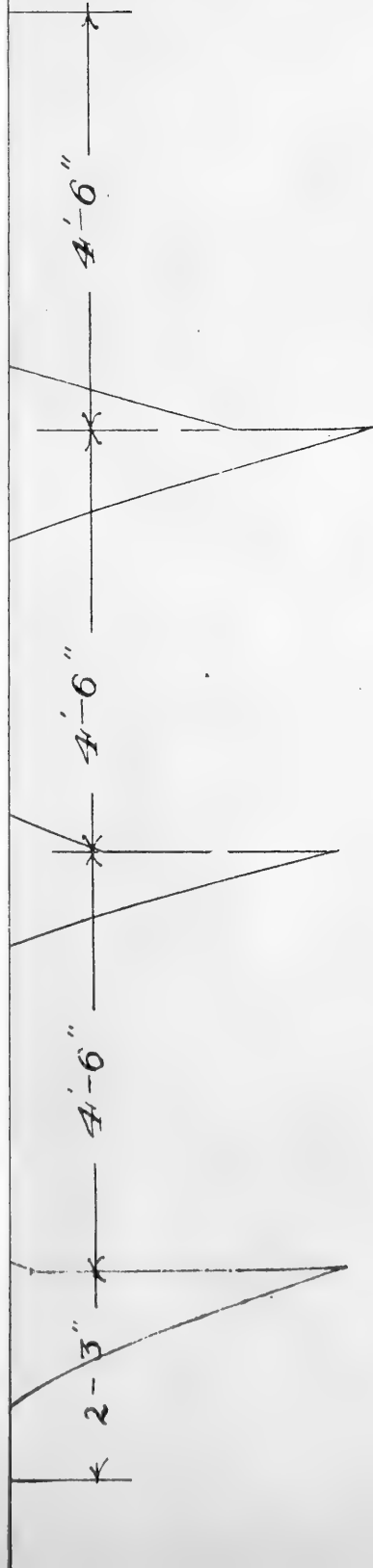
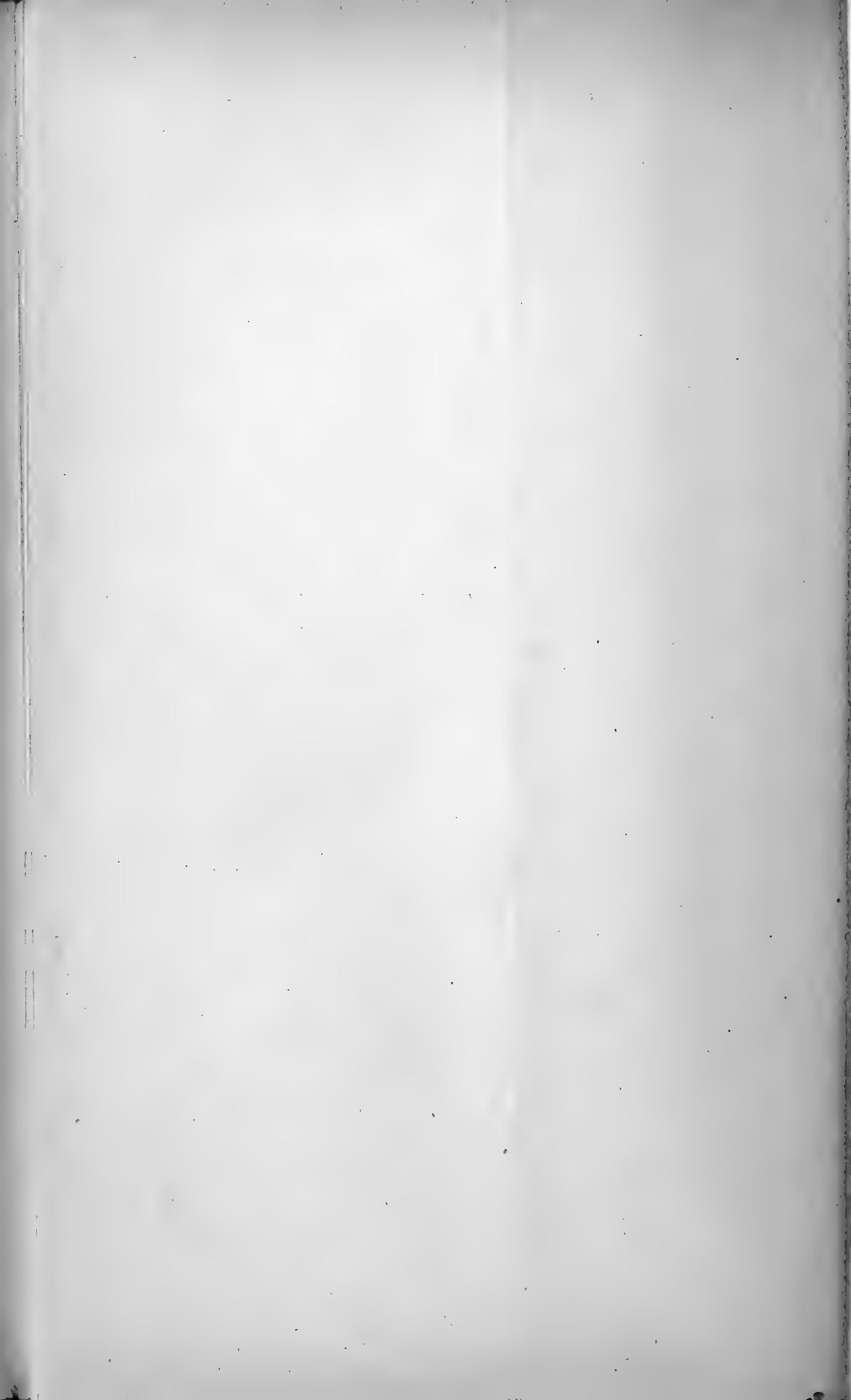

Fig. 8.
Bending moment diagram reduced to horizontal base.



Scale of Bending Moments

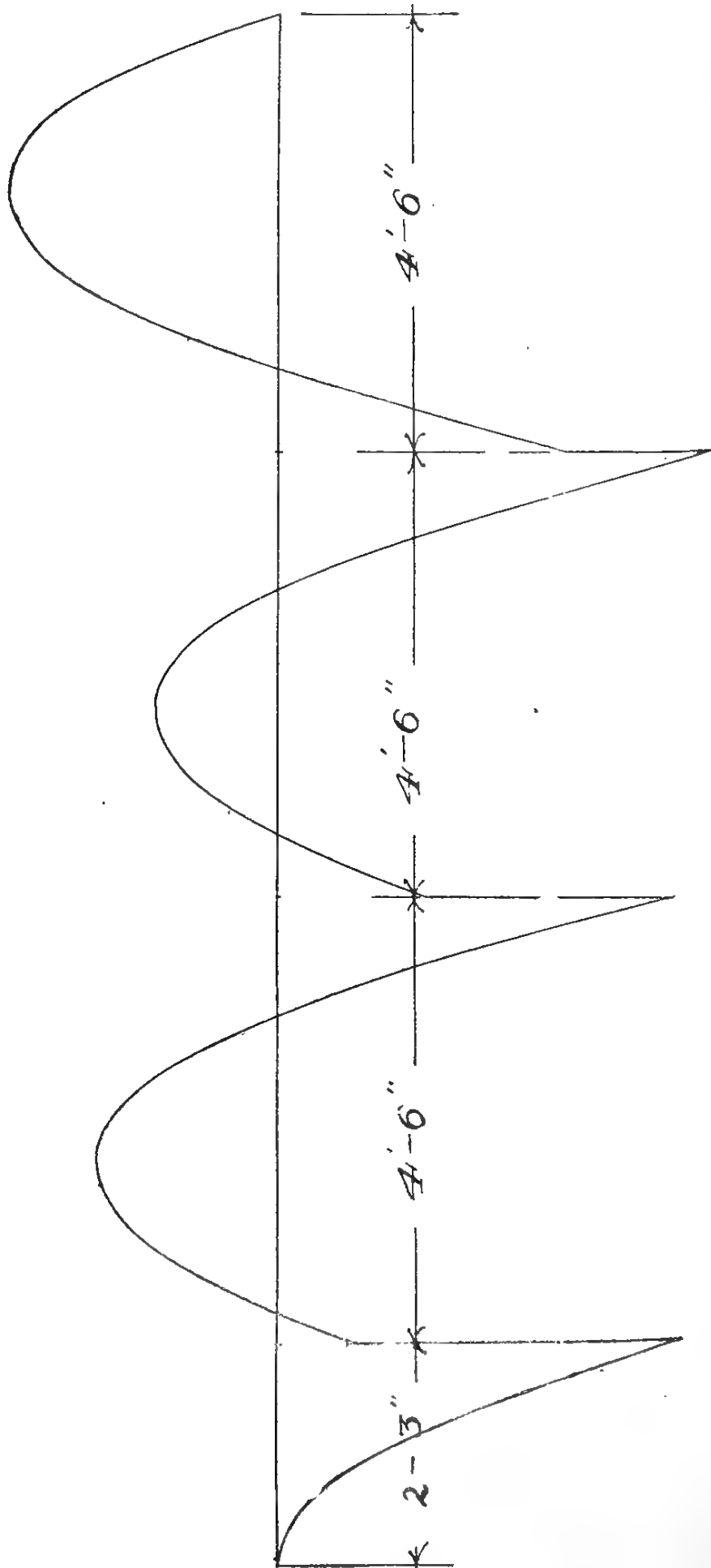

Fig. 8.
Bending moment diagram reduced to horizontal base.



**III. Studies in the Morphology of *Isoëtes*. I. The
General Morphology of the Stock of *Isoëtes lacustris*.**

By WILLIAM H. LANG, M.B., D.Sc., F.R.S.,

Barker Professor of Cryptogamic Botany in the University of Manchester.

(*Read December 1st, 1914. Received for publication December 7th, 1914.*)

INTRODUCTION.

Isoëtes has been studied by many investigators and it might be assumed that its morphology was so well known as to render further description needless. While this is true of many facts regarding its life history and structure, the morphological problem presented by this peculiar and isolated genus of existing Vascular Cryptogams remains difficult and fascinating. Its re-statement in the present series of papers will lead to the critical consideration of a number of features in the construction of the stock, the relation of the leaves and roots to the upper and lower regions of the stock respectively, and the progressive growth of the plant as a whole, from the older embryo to the adult condition.

The term stock will be used for the tuberous axis of *Isoëtes* instead of the word stem, since one of the main questions at issue is whether this axis is best regarded as a short stem bearing peculiarly arranged adventitious roots, or as composed of an upwardly growing region bearing the leaves and a downwardly growing structure bearing the roots. This lower region of the stock may, without pre-judging its morphological nature, be contrasted

February 6th, 1915.

with the shoot as the rhizophore or rhizophoric region of the stock.

To determine the place of a plant in the natural system and its relations to other plants, living or extinct, is one of the objects with which morphology is studied. The morphological problems presented by a plant are, however, by no means solved when its affinity or phylogeny is determined with reasonable probability. This holds for *Isoëtes*, where indeed the probable phylogeny adds greatly to the interest of the study of the morphology.

Various affinities have at different times been suggested for *Isoëtes*, but there appears to be preponderating evidence for the view that it belongs to the Lycopodiales and is most directly related to the heterosporous arborescent forms that flourished in the Palæozoic period. This view has been stated in more recent times by, among others, Potonie,¹ Scott² and Bower,³ all of whom have studied *Isoëtes* in the light of comparison with the extinct plants forming the Lepidodendreae in the wide sense, or as they are sometimes called, the Lepidophytinae. This affinity is expressed in Potonie's treatment of the groups concerned in the "Natürlichen Pflanzenfamilien," and most recently by Scott in his book on "The Evolution of Plants." After considering the features of the Lepidodendreae and of the Triassic plant *Pleuromeia*, Dr. Scott sums up the question by saying that the Lepidodendreae "may have become wholly extinct early in Mesozoic times, or may possibly have left a dwindling race of degenerate descendants, which reached their final stage of reduction in the dwarfed plantlets of the amphibious *Isoëtes*." With this view of the probable relationship of

¹ "Nat. Pflanzenfamilien."

² "Evolution of Plants."

³ "Land Flora."

Isoëtes I am in agreement and do not propose to discuss the phylogenetic question further here.

While certain detailed resemblances (especially in the root, leaf-base, ligule and sporangium) justify the inference of relationship between *Isoëtes* and the Lepidophytinæ, larger morphological questions remain, and are only made more interesting by the suggested phylogeny. How are we to compare the total organisation of an *Isoëtes* plant with that of *Lepidodendron* or *Sigillaria*? What are we to understand in detail by *Isoëtes* representing the last stage of reduction of the *Lepidodendron* type? Can we trace a distinction of a leaf-bearing shoot and a root-bearing basal region in *Isoëtes* corresponding to the striking distinction of these regions in the Lepidodendreaë! Such questions invite detailed and critical consideration of the morphology of the stock of *Isoëtes* as expressed in its adult structure, its continued growth and its ontogeny. In this series of papers it is hoped to make some contribution to this necessary preliminary to further comparison between *Isoëtes* and the Lepidophytinæ.

GENERAL MORPHOLOGY OF THE STOCK OF *Isoëtes lacustris*.

This paper will deal with some features of the general organisation and gross anatomy of the stock of *Isoëtes*, leaving details for consideration in subsequent papers. The uniformity of general organisation in the genus *Isoëtes* makes it probable that conclusions derived from the study of one species will hold in the main throughout. The description in this preliminary paper will be limited to the usual two-lobed stocks of our native *Isoëtes lacustris*, partly because abundant material could be obtained and partly because the various planes of section can be readily defined in the case of the two-lobed stock.

Some preliminary remarks on the history of our knowledge of *Isoëtes*, and especially as to the various interpretations of the morphology of the stock, will make the reason for re-opening the question clear. It is only necessary to deal with a few historically important papers and with the main interpretations of the morphology. Two such interpretations are apparent in the earlier investigations that laid the foundations of our accurate knowledge of the structure of *Isoëtes*. The one was clearly stated by Von Mohl⁴ in 1840; the other by Hofmeister⁵ in 1855. For our purpose it will be sufficient to bring out the essential differences between the views of these two investigators, and to follow the history of their respective interpretations to the present time.

In Von Mohl's clear and well-illustrated account of the general macroscopic anatomy of the two-lobed stock of *Isoëtes lacustris* all the main facts of its morphology and structure are shown; the position of the cambium and of the peculiar secondary zone is indicated in the figures, although its nature was not recognised. Von Mohl devoted special attention to the arrangement of the roots on the lower region of the stock. Recognising the shoot nature of the upper portion of the latter, he discusses the question whether *Isoëtes* possesses a "caudex descendens" on which roots are borne in acropetal order. He points out that the roots can be regarded as standing in flattened ellipses around a lower growing point drawn out in the plane of the groove. The peculiar shape of the half-moon-shaped, root-bearing region of the vascular axis is consistent with this explanation. The relationship of *Isoëtes* to other Vascular Cryptogams (*Lepidodendron* did not at

⁴ *Linnaea*, 1840. Reprinted in "Vermischte Schriften," p. 122.

⁵ *Abh. math.-phys. Kl. d. K. Sächs. Ges. d. Wiss.*, 2, p. 123, and later in "Higher Cryptogamia" (1862), to which references are made here.

this date enter into the comparison) is a difficulty in recognising a "caudex descendens." In other Vascular Cryptogams such a region is wanting, the adventitious roots being borne in ascending order on the shoot. If, however, the roots of *Isoëtes* are regarded as adventitious they present a remarkable exception to the order in which roots arise in other plants. Von Mohl left the important question, he had so clearly raised, in some degree open, while evidently inclining to the view that the roots in *Isoëtes* do arise in acropetal succession in relation to a peculiarly shaped, downwardly growing region of the stock.

Another interpretation of the stock of *Isoëtes* was given in the classical work of Hofmeister and has remained on the whole the accepted view to the present time. The acropetal succession of the successive series of roots in relation to a downwardly growing region is admitted but explained as "only an *apparent* irregularity, depending upon the unusually vigorous development of the bark, and its yearly renovation from within outwards." The roots are regarded as standing in vertical lines parallel to the the grooves and in each vertical line the oldest roots are said to stand nearest to the base of the stock and the youngest nearest to the stem apex. For further details of Hofmeister's interpretation of the arrangement of the roots of *Isoëtes*, reference must be made to the original account, which on this subject is not altogether clear. What has been said will show how it differs from Von Mohl's interpretation, although on both the root-bearing region of the stock of *Isoëtes* is seen to be peculiar and anomalous among existing Vascular Cryptogams.

Von Mohl's interpretation, which recognised the root-bearing region as in a sense the correlative of the shoot, was practically replaced by Hofmeister's, and hardly figures in the literature until recently. In 1909 Miss

Stokey,⁶ in a paper mainly concerned with the histology of the secondary tissues, suggested that the tuberous stock of *Isoëtes* "is not wholly stem, but a contracted stem and main root." She does not, however, enter further into the question, nor extend the comparison to extinct plants. In the following year I re-stated the interpretation of Von Mohl and Williamson's comparison (referred to in the next paragraph) with the *Lepidodendrea*, in a short communication⁷ to the British Association at Sheffield, but the grounds for my opinion have not been published in detail until now.

The comparison of the root-bearing region of the stock of *Isoëtes* with the Stigmarian base of the *Lepidodendroid* trees had been made by Williamson⁸ in 1887. In his monograph on *Stigmaria*, by then recognised as the root-bearing region of extinct plants belonging to Lycopodiales, he refers to the interest of the similarity between the roots themselves of *Isoëtes* and *Stigmaria* and also of the way in which they are borne. He states, "In both organisms these rootlets are given off from the lower part of a downward prolongation of a caulome, which prolongation never develops leaves; the rootlets, therefore, are produced upon an axis which grew in the opposite direction to that in which the leaf-bearing part of the stem grew."

The fundamental importance of this comparison between *Isoëtes* and the *Lepidodendrea* is evident. How completely it has passed into abeyance, however, is shown by the fact that in recent discussions⁹ of the mor-

⁶ *Bot. Gazette*, 47, p. 311.

⁷ *British Ass. Report*, 1910, p. 784.

⁸ *The Palaeontographical Society*. Vol. for 1886. (London, 1887.)

⁹ Only a general reference need be made to such works as Bower's "Land Flora," Scott's "Fossil Botany," and Seward's "Fossil Plants."

phology of *Stigmaria* the root-bearing region of *Isoëtes* is not mentioned, while comparisons are drawn with the rhizophores of *Selaginella*, the basal root-bearing swelling of *Selaginella spinulosa*, and with such further removed structures as the root-bearing region of *Phylloglossum* and the leafless rhizomes of *Psilotum*. Considering the close comparison always made between other features of *Lepidodendrea* and *Isoëtes*, it is clear that, if Williamson's comparison of the root-bearing regions is well founded it has more direct morphological significance than any of the others suggested.

The reason why this comparison has been abandoned seems to be that all later work on *Isoëtes* has followed Hofmeister's interpretation in regarding the roots as arranged in vertical lines on a stem, and their production and the downward growth of the stock as due to the secondary meristem. This is the view taken in the full and important investigation of the three-lobed stock of *Isoëtes hystrix* by Scott and Hill.¹⁰ In that paper, the arrangement of the roots in vertical lines is described in detail but their development from the meristem is not dealt with. No comparison with the *Lepidodendrea* is made by Scott and Hill as regards the root-bearing region.

After this brief survey of the history of opinion on the morphology of the stock of *Isoëtes* the main facts of construction as shown in two-lobed plants of *I. lacustris* may be re-examined, although the result of this is on the whole simply to confirm Von Mohl's description. The re-description will, however, bring some additional features into prominence and group the facts for convenient consideration.

The external form of the two-lobed stock of *I. lacustris*

¹⁰ *Annals of Botany*, XIV., 1900, p. 413. cf. especially pp. 430, 431.

is well known, though many of the published figures are not accurate in detail.¹¹ It is important to start with a clear idea of the form of the stock and of the nature of the surfaces bounding it, and the accompanying diagram (*Fig. 1*) will assist in this. The mature functional leaves are arranged spirally and stand in a close group around the summit of the stock. They conceal and protect the conical apical depression on the sides of which stand the developing leaves for future seasons. The cortex bearing the functional leaves is still intact but the older

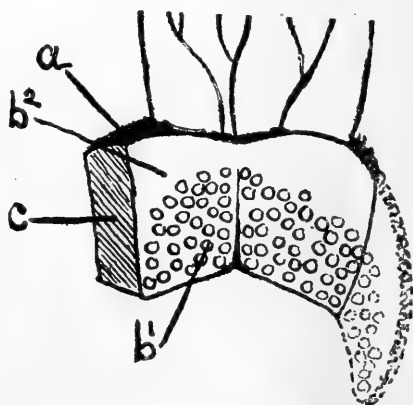

Fig. 1.—Diagram to illustrate the surfaces of a two-lobed stock of *Isoetes*.

Description in the Text.

leaf-bearing cortex is split into the two lobes, the upper surface of which bears the withered bases of the leaves of former seasons. This leaf-bearing surface (*Fig. 1, a*) is clearly part of the true outer surface of the shoot. On the other hand, the splits that divide the leaf-bearing cortex into the two lobes expose surfaces (*Fig. 1, b²*) that cannot be regarded as parts of the true outer surface of the plant. These splits in the leaf-bearing cortex are the continuation upwards of the groove or split across the

¹¹ The figures reproduced in Seward's "Fossil Plants" (Vol. II., Fig. 132) show the position of the roots and root-scars accurately.

lower aspect of the stock, which progressively exposes new roots on the surface. The root-bearing surface (*Fig. 1, b¹*) thus exposed bounds the lower face of the lobes and the lower portion of their sides. It also is in its origin a split surface, but it will have to be considered later whether it does not in a sense represent a portion of the true outer surface of the plant. The splitting in the root-bearing region is a necessary expression of the active growth and differs from the passive splitting induced by it in the leaf-bearing cortex. The older cortex, both leaf-bearing and root-bearing, is thus divided into two lobes. The tissue composing the distal older portions of these perishes. The dead tissue is not actually shed, but when it decays or is removed the end of the lobe is bounded by a scar-surface (*Fig. 1, c*). This is obviously not a portion of the true outer surface of the plant.

We thus distinguish as surfaces of the stock (*Fig. 1*):

- a.* The true external leaf-bearing surface.
- b.* The split surface of the groove below and extending up the sides of the stock.
 - b¹.* Split surface bearing roots.
 - b².* Split surface in leaf-bearing cortex.
- c.* Scar surface at ends of lobes when dead tissue is removed.

The internal construction of the stock must be thought of in the solid, either on the information supplied by a complete series of transverse sections or by combination of sectional views in different planes. This is most easily done in the case of two-lobed plants, where longitudinal sections can be definitely orientated in the plane of the groove or the plane of the lobes, but there is no difference in principle between the construction of such plants and that of the three- or four-lobed stocks.

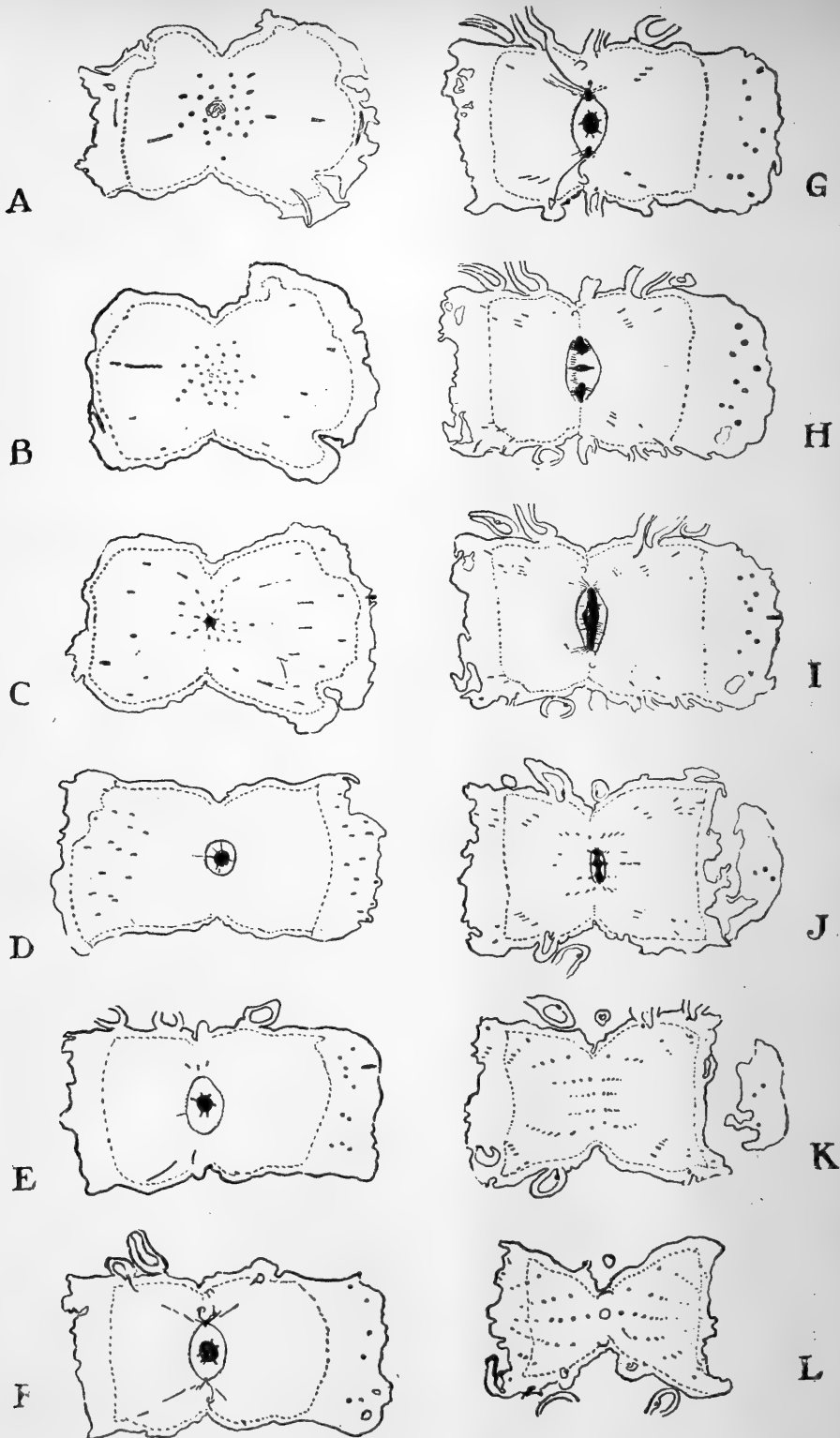

Fig. 2.—Outlines of selected sections of a transverse series through a stock of *Isoetes lacustris*. In this and the three following figures the primary stele of the stem and rhizophore is black. The line outside this marks the position of the secondary meristem, the prismatic tissue occupying the position of the space between this and the primary stele. The leaf-traces and root-traces are shown in the cortex. Further description in the Text.

(The outlines in this figure and in Figs. 3, 4, 5, were obtained by drawing over photographs and then destroying the photographic picture, leaving the outline.)

Selected sections from a complete series of transverse sections through one plant are represented in outline in *Fig. 2 A—L*. In *A* the plane of section passes through the stock above the level of the stem apex, so that in the centre the apical depression with young leaves projecting from its sides is cut across. The next section (*B*) is just below the level of the apex, so that the central hole has disappeared, the section passing through the procambium above the summit of the stele. The latter is distinct and lignified at the level of *C*, but has no secondary zone of prismatic tissue. In these figures the two-lobed nature of the stock is recognisable, but it is clear that the leaf traces to the functional and young leaves stand symmetrically around the apex and summit of the stele in a complicated spiral. At the level of *Fig. 2 D* the secondary zone produced by the meristem is well marked. The bases of leaf-traces evident around the stele belonged to the leaves of former seasons. The whole of the cortex belongs to the shoot, no roots being evident at this level. In the section shown in *Fig. 2 E* the cortex belongs mainly to the shoot region, but beneath the groove root-traces are seen in the cortex, and the bases of roots are visible on the split surface extending from the groove. The level of the section is above the point of origin of the highest root-traces from the central vascular axis. In *F*, however, at a slightly lower level the tips of the upward extensions of the half-moon-shaped rhizophoric region of the woody axis are cut across and these are more marked in *G*. The root-traces are seen extending outward from these, while young roots not yet exposed on the surface have their tips pointing towards the plane of the split. It will be noted that the outer level of the rhizophoric xylem coincides with the line of meristem round the stem-stele. So far the outline

of the latter has been circular, corresponding to the spiral arrangement of the leaves in the later stages of growth of the plant. In the section figured in *H*, however, the primary stele of the stem is seen to be small and lens-shaped with the two-ranked leaf-traces pointing in the plane of the lobes; this is the stele of the plant in the first season of its growth, when the divergence of the leaves was $\frac{1}{2}$. The section is just above the level at which the stem stele passes into the rhizophoric region of the vascular axis. *Fig. 2 I*, almost immediately below the preceding, is below the stem stele and cuts across the root-bearing region of the vascular axis, extended in the plane of the groove. The bases of old root-traces are seen attached to this, embedded in a secondary prismatic layer, just as the old leaf-traces stood in relation to the stele of the stem. In *J* the rhizophoric stele is seen cut nearer to its convex lower end and therefore shorter in the plane of the groove. Section *K* passes just below the rhizophoric stele, while section *L* is still lower and just above the opening out of the groove on the under side of the stock. In these sections the characteristic arrangement of the root-traces in the cortex is shown.

If this series of transverse sections is considered as a whole, it will be seen to suggest the existence of two distinct regions of the vascular axis, an upper one belonging to the shoot and bearing the leaf-traces, and a peculiarly-shaped lower region upon which only root-traces are borne. The junction of the two regions lay between *H* and *I* in *Fig. 2*. Not only can these two regions be distinguished in the axial region of the stock, but, when the distribution of the leaf-traces and root-traces are taken into account, corresponding regions of the cortex can be recognised. The root-bearing cortex forms the lower part of the lobes and extends upwards in

the region of the grooves to a level higher than the tips of the horns of the rhizophoric stele (*cf. Fig. 2 E, F*). The leaf-bearing cortex surrounds the apical region of the stem, forming there the whole of the cortex seen in transverse section, and, after splitting has occurred, it forms the upper portion of the two lobes.

The shape of the vascular axis of the two-lobed plant can be deduced from such a series of transverse sections. The cylindrical primary stele of the upper portion of the shoot narrows below where the stele of the young plant persists. Below this region the rhizophoric stele broadens out suddenly, being extended in the plane of the groove. The meristematic line, by means of which additions were made to the rhizophoric region, lay just outside the convex lower edge and its ends coincided with the meristem around the base of the stem stele. The more or less upturned tips of the rhizophoric stele also coincide in position with the meristematic layer which gives rise to the secondary prismatic tissue. The expansion of the rhizophoric stele was rendered possible by the development of secondary tissue around the narrow basal region of the stem stele. The upturned tips of the rhizophoric stele may be more directly due to the secondary meristem. These tips are well marked in this stock, but in others may not be represented, the rhizophoric stele simply broadening out below the base of the stem stele, as allowed by the development of secondary tissue around the latter. The shape of the whole primary vascular axis may be compared to the edging iron used in horticulture, the stem stele corresponding to the handle and the rhizophoric stele to the half-moon-shaped blade.

These inferences as to the shape of the vascular axis are borne out, as was shown in Von Mohl's figures, by longitudinal sections in the planes of the lobes and of the

groove. Since such sections bring other features of importance into prominence they must be briefly described.

Sections in the plane of the lobe will obviously cut

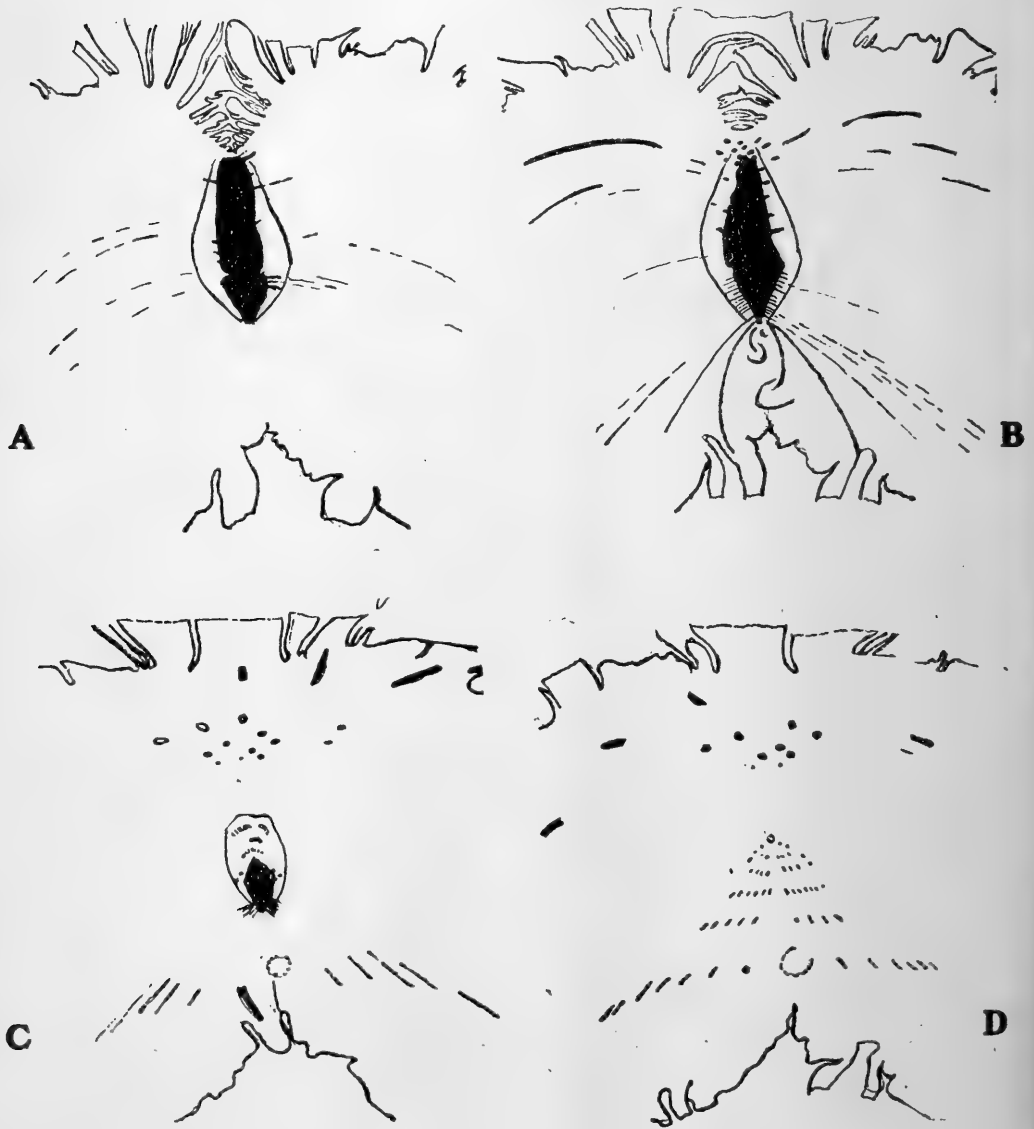

Fig. 3.—Outlines of four longitudinal sections in the plane of the lobes through a large stock of *Isoetes lacustris*.
Description in the Text.

the root-bearing extension of the stele at right angles to the growing edge. Four sections from a longitudinal

series of a large plant in this plane are represented in outline in *Fig. 3 A—D*. In *A*, which is the median section, the position of the depressed apex and the relation to this of the developing leaves and the functional leaves is seen above, while the position of the groove and the plane of the progressive splitting is recognisable below. The vascular axis is clearly distinguishable into the region belonging to the stem and the lower rhizophoric region. The junction of the two regions has been broadened by a process of stretching involving rupture of the tissues. A well marked zone of secondary prismatic tissue has been developed around the older portions of both the stem stele and the rhizophoric stele. The plane of this section did not follow any of the orthostichies of root-traces and only indications of older leaf-traces were seen in this section. In the section represented in *Fig. 3 B*, however, the position of the developing roots and the course of the root-traces are shown. It is noteworthy with regard to these that the roots are developed a short distance below the lower end of the vascular axis, close to the lower meristem. The root-tips at first point towards the plane of the future split and, on this taking place, stand at right angles to the exposed surface. The course of the root-traces in the cortex corresponds to this, being curved until the root-tips are exposed on the surface and then nearly straight. The roots stand in acropetal order in relation to the downwardly growing rhizophore. The arrangement of the young roots and the root-traces thus exhibits a striking correspondence with the relations of the young leaves and their leaf-traces to the depressed growing point of the shoot. These points are further illustrated in *Fig. 5* which represents a median longitudinal section in the plane of the lobes through a smaller but complete plant. The other two sections in *Fig. 3* are sufficiently far

removed from the median plane to miss the primary stele of the stem. The section in *Fig. 3C* cuts across the extension of the rhizophoric stele. The secondary prismatic tissue seen above this belongs to the base of the stem stele and has allowed of the extension of the rhizophoric stele in the plane of the groove. The section in *D* passes just outside the tip of this arm of the rhizophoric stele and shows the arrangement of the root-traces in the rhizophoric cortex below the groove. Scattered leaf-traces are seen in the upper region of the cortex in this and the other sections in *Fig. 3*.



Fig. 4.—Outlines of median longitudinal sections in the plane of the groove through two stocks of *Isoetes lacustris*.
Description in the Text.

Longitudinal sections in the plane of the groove follow the extension of the rhizophoric stele. Just outside the convex edge of this lies the meristem, which determines on the one side the increase of the vascular tissue and on the other the production of new roots and the growth of the cortex of the rhizophoric region. Outlines of longitudinal sections of two stocks in this plane are given in *Fig. 4*. In these the distinction is evident, not only between the stele of the stem and the rhizophore,

but also between the root-bearing and leaf-bearing regions of the cortex. Since the plane of section follows approximately the line of the future split, it may show the tips of young roots belonging to both sides of the rhizophore (*cf. Fig. 3 B*). The arrangement and succession of roots will not be dealt with here, but it may be noted in passing that a strict arrangement in vertical lines, the youngest roots being nearest the stem apex, is not self-evident. This question will require careful consideration, but the succession in vertical series (which is often more apparent than in these sections) is mentioned here, since, if established, it is one of the difficulties in recognising the lower growing line as the correlative of the shoot apex.

In the stock represented in *Fig. 4 B*, the widening of the rhizophoric stele has been allowed for by the development of secondary tissue around the base of the stem stele (and partly by the stretching and disorganisation of the narrow basal region of the latter), but the secondary meristem has not contributed to the extension of the growing line itself. On the other hand, in stocks like *Fig. 4 A*, with which *Fig. 2* may be compared, the rhizophoric region of the stele is continued upwards parallel to the lower part of the stem stele, and this extension appears to be due to the meristem of the stem contributing to the increase of length of the lower growing line and altering its behaviour accordingly. This, while not proving the rhizophoric region to be merely a peculiar secondary growth, indicates the close relation between the deep-seated growing line of the rhizophoric region and the secondary meristem.

All the plants hitherto considered are of the usual type found in full grown plants in having a secondary zone of prismatic tissue, developed within a cambium, around the older portions of both stem stele and rhizo-

phoric stele. Occasionally, however, equally large plants are met with in which this secondary growth is almost completely wanting. In such stocks the only secondary growth is around the narrow base of the stem stele; the small amount of prismatic tissue formed there allows of the widening rhizophoric stele fitting on to the stem stele without dislocation of the cortical tissues. Plants of this type are of great interest as bearing on the distinction of the primary structure and on the part played by the secondary meristem in the growth of the stock.

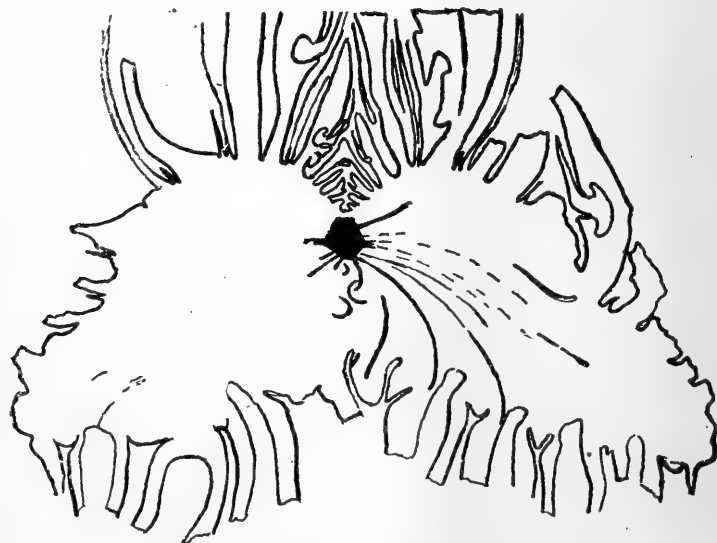

Fig. 5.—Outline of a median section in the plane of the lobes through a complete plant of *Isoetes lacustris*. The cambium and secondary prismatic tissue could not be indicated on this scale.

Description in Text.

In relation to this a word may be said as to the nature of the continued cortical increase, which, as *Fig. 5* shows, carries the older leaves and roots outwards, providing room for the more recently formed and functional leaves and roots. This cortical extension has, since Hofmeister's work, usually been described as due to the activity of the secondary meristem. An alternative explanation, dealt with in greater detail below, is to regard it as a continua-

tion of the increase in depth of cortex found in the apical growth of all ordinary roots and shoots. In *Isoëtes*, however, the process continues throughout life in relation to the very slight growth in length of the stock. What is undoubtedly cortical extension is seen in young plants of *Isoëtes* before a secondary meristem is established. Two other pieces of evidence from the older plants in support of this alternative explanation of the cortical growth may be noted. They are (1) the fact that the older leaf- and root-traces are stretched throughout their whole length and not only at the level of the cambium, and (2) the fact that cortical extension continues as usual in stocks where there is practically no secondary growth and in which a secondary meristem is only developed at the base of the stem stele.

The main facts as to the construction of the stock of *Isoëtes* have been reviewed in the preceding paragraphs and may now be considered in their bearing on the morphology of the stock. Two alternative interpretations of this, especially as regards the nature of the lower root-bearing region, were evident from the survey of the work of previous investigators.

The following features may be regarded as supporting the view that the root-bearing region is a result of the peculiar secondary growth of the stem and is not to be regarded as a "caudex descendens" or rhizophore correlative with the upwardly growing shoot:—

(a) The coincidence of the deeply-seated growing line of the rhizophoric region with the meristem around the base of the stem stele.

(b) The frequent extension upwards of the horns of the rhizophoric portion of the central vascular axis, at the expense of the adjacent secondary meristem of the shoot.

(c) The appearance of an arrangement of the roots in

vertical lines, the lowest roots in each line being the oldest.

These points will all require to be examined in detail and they undoubtedly suggest a relation between the growing line of the rhizophoric region and the secondary meristem of the shoot. They do not however prove that the rhizophoric region is merely a peculiar secondary growth, nor do they suggest any explanation of some striking features of the lower region of the stock, especially of the orientation of the roots to the growing line. It is difficult on this view to understand either the mode of growth of the rhizophoric region or its comparative morphology.

The following features, on the other hand, support the interpretation of the lower region of the stock as a distinct downwardly growing rhizophore, with a deeply sunken and extended growing line. Growth proceeds from this as if the apical region was not merely depressed (as the stem-apex is), but enclosed by the congenital coherence of the opposed sides of the depression; the root-bearing surface is later exposed by the splitting process at the groove.

a. The acropetal succession of the roots in relation to the growing line.

b. The fact that the roots, which develop close to the growing line, do not penetrate the cortex, but are carried outwards until exposed by the splitting process as practically exogenous organs.

c. The direction of the young root-tips to the plane of the future split, and the peculiar curvature of the traces of the young roots.

d. The regular orientation of the structure of the roots in relation to the growing line, the protoxylem always being turned towards this.

e. The difference in the cortical growth in relation to the rhizophoric growing line from that outside the secondary meristem in other regions of the plant.

f. The correspondence between the growth of the rhizophoric region of the stele and in the relation of the roots and root-traces to it on the one hand, and the growth of the stem stele and the relation of the leaves and leaf-traces to it on the other.

The divergence of opinion as to the morphology of the stock of *Isoëtes* and the imperfect treatment in the text-books indicate that the problem is not a simple one. The arrangement of the roots can be *described* from either of the alternative points of view and both recognise that, in the way its roots are borne, *Isoëtes* is peculiar among existing Pteridophyta. In seeking for the explanation which best fits with all the facts of structure and development it is important to avoid pre-conceptions. It is indeed possible that both the interpretations suggested may be in a measure correct and that the downward growth may be associated in its origin with the peculiar meristematic growth, but, once initiated, may behave like a primary growing point in the production of lateral members. In spite of the difficulties that have been mentioned above, the recognition of the lower region of the stock of *Isoëtes* as a rhizophore in some way correlative with the upwardly growing shoot appears to be justified. This interpretation may now be tested by seeing how it (1) gives a connected explanation of a number of peculiarities in the growth and construction of the individual plant and (2) facilitates morphological comparison with other plants that are probably more or less directly related.

In considering the explanation of the growth and structure of the *Isoëtes* stock itself it must be remembered that the peculiarity of its growth is conditioned by the

fact that the production of new leaves and roots proceeds with very little longitudinal growth of the axis. This has

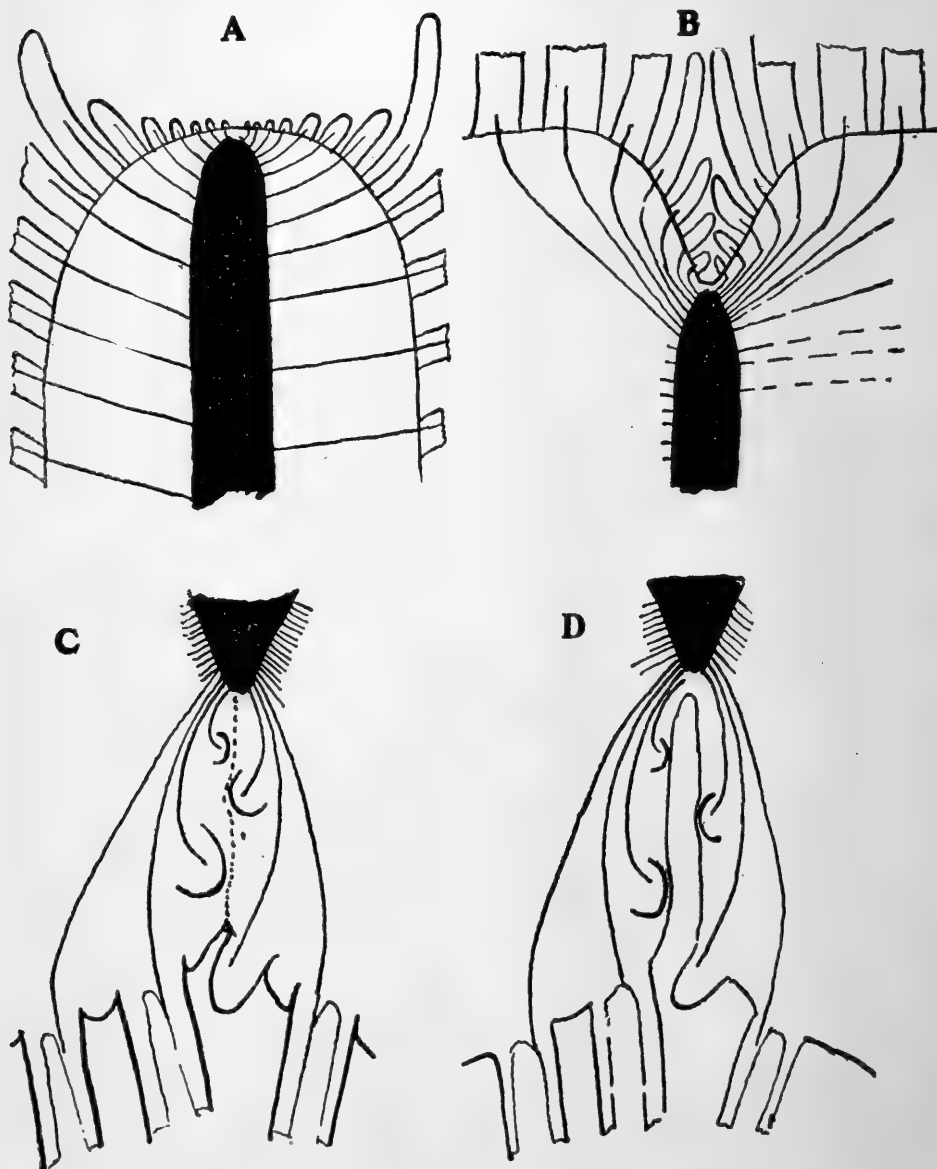

Fig. 6.—Diagrams to illustrate growth of a convex apex (*A*), of the apex of *Isoetes* (*B*), and of the lower region of *Isoetes* (*C* and *D*). Description in Text.

been pointed out by Scott and Hill and by other investigators, but its effect has not been analysed in detail. In

the case of the apical growth of a shoot with normal longitudinal growth (*Fig. 6 Diagram A*) the thickness of the cortex increases behind the growing point until the definitive primary diameter of the stem is attained. The growth in length in the region of elongation provides the surface for the insertion of the full-sized functional leaves and carries the apical region forward. The slow growth of the apical region itself, depending on the multiplication of the meristematic cells, affords space around the actual growing point for the appearance of new leaf-rudiments. In the case of the shoot of *Isoëtes* (*Fig. 6, Diagram B*) on the other hand, the elongation of the central region is quite insufficient to allow of an extension of surface for the insertion of the large leaf-bases. The slight increase in length of the central region of the shoot, comprising the stele and the inner region of the cortex, depends on the addition of new elements by transformation of meristematic cells and not on a region of elongation. The surface bearing the leaves must, however, increase in area with the enlargement of the leaf-bases to their full size, and this is permitted by the cortical rows of cells increasing in radial depth and so carrying the leaf-bearing surface further from the axis. These processes result in the deep-seated position of the apex of the stem in *Isoëtes* and in the progressive carriage of the leaves out from the apex. This outward carriage continues and removes the old leaf-bases still further from the axis to make room for a new set of functional leaves (*cf. Fig. 5*).

Whatever the morphological explanation of the origin of the lower growing region of the stock may be, the mechanism of the progressive carriage outwards of the young roots and the further removal of the older roots to make room for new functional ones is essentially similar to that of the outward carriage of the leaves from the

shoot-apex. As in the case of the stem, there is only a slow addition to the vascular axis of the rhizophore behind the deeply seated growing line. The rhizophoric stele and the inner portion of its cortex undergo no subsequent longitudinal extension. The elongation of the rhizophoric stele is only sufficient to allow of the insertion of the new root-traces. It is, however, no more correct to say that the rhizophoric stele is simply due to the union of the bases of the vascular bundles of the roots, than to say that the stem-stele is due to the union of the bases of the leaf-trace bundles. The production of new tissues to the sides and outside of the growing line is quite unlike the cortical growth outside the secondary meristem at other regions. It is clearly related to a plane continued inwards from the split of the groove to the meristem and proceeds as if this represented the plane of fusion of the opposed sides of an apical depression. The evidence for this will be given in a detailed study of the segmentation in a later paper, but the accompanying diagrams (*Fig. 6, Diagrams C, D*) will serve to make the main idea of the interpretation clear and show how naturally it agrees with the position of the young roots and the course of their traces. In *Diagram C* the line of the future split inwards from the groove is represented by a dotted line, while in *Diagram D* this is represented as a deep narrow depression continuing down to the growing line; the former corresponds to the actual structure as shown in *Fig. 3 B* and *Fig. 5*, while *Fig. 6 D* is imaginary and explanatory. As in the case of the cortical growth around the apex of the shoot, a distinction has to be made between an outer region of the cortex, increasing in superficial area as the root-bases enlarge, and an inner region of the cortex, increasing in radial depth by tangential divisions. The latter process carries the areas of outer cortex, bearing

the roots, outwards, until exposed at the split, and continues to effect the progressive carriage of the older roots away from the groove. It is consistent with this explanation that there is no penetration of the cortex by the roots themselves. These, as exposed at the groove, are seen to stand as practically superficial and exogenous structures, with projections of the free cortical surface between their bases (*Fig. 5*). The root tip, though developed close to the growing line, has been passively carried out by the radial extension of the cortex. Thus the position of the roots, the direction of the young root-tip to the plane of the split and the curve of the root-traces all find a natural explanation in this way of looking at the growth of the rhizophore, while they are meaningless on any other view. It is also clear that the nature of the development involves the recognition of a root-bearing region of the cortex distinct from the leaf-bearing cortex of the shoot and indications of this distinction have been noted in all planes of section through the stock.

The growth of the upper and lower regions of the stock of *Isoëtes*, though separately considered in the preceding paragraphs, is, of course, correlated in the plant as a whole. The progressive cortical increase, resulting in the cortical lobes, stretches and obliterates both the older leaf-traces and root-traces. The correlation between the growth of the shoot-cortex and rhizophoric cortex will be evident on consideration of the median section of a complete plant in the plane of the lobes in *Fig. 5*.

Having now seen how the view that the stock of *Isoëtes* is composed of a shoot and a rhizophore affords a satisfactory and connected explanation of the chief peculiarities of structure and growth of the individual plant, we may in the second place briefly enquire how this view lends itself to comparison with other plants.

The primary distinction of the body of Gymnosperms and Angiosperms into main root and shoot is not strictly comparable and may be left out of consideration with the remark that it presents interesting analogies. In the Pteridophyta the primary root of the embryo does not develop, in any known case, into a main root producing the whole root-system of the plant. In Ferns and *Equisetum* so-called adventitious roots are borne in ascending order, either all along the shoot or limited to the lower region. This is also the case in *Lycopodium*, but in the Lycopodiales we also find plants with the roots confined to the basal region. It is with these that *Isoëtes* can be compared in this respect and it is of interest to find that the genera in question (*Selaginella*, *Pleuromeia*, *Lepidodendron*, *Sigillaria*) are all plants with which it is probably more or less directly related; this is shown by the agreement in other morphological features. The comparison with *Selaginella* is somewhat distant, though interesting, the interest being increased by the existence of additional rhizophores borne on the shoot. It is sufficient here to mention the development of two roots in addition to the primary root at the basal region of the young plants of most species, and the more marked basal root-bearing region of *Selaginella spinulosa*. In the latter all the roots are produced in regular succession on the basal region, the central vascular system of which is modified in relation to the root insertions.

The comparison with the root-bearing region of *Pleuromeia* or the *Lepidodendreae* is more direct, in view of the possible phylogenetic connection between them and *Isoëtes*. In making it the peculiarities in the stock of *Isoëtes* due to the absence of growth in length must be borne in mind and allowed for. If both shoot and rhizophore of *Isoëtes* be supposed to undergo sufficient

longitudinal growth to allow of surface for the insertion of the leaves and roots, there would be no progressive increase of the cortical lobes. Both the shoot stele and the rhizophoric stele would be clothed with their respective cortex, the form of the plant being given by that of the stele, and the lobes therefore corresponding in position with the grooves of the *Isoëtes* plant as we know it.¹² Such a plant would have a remarkable resemblance to *Pleuromeia*, in that the cylindrical stem would end below in a lobed region, without evident localised growing points, bearing all the roots of the plant exogenously. If, further, we suppose the growth of the rhizophoric region of this *Pleuromeia*-like plant localised near the tips of the lobes and ceasing along the lower portion of the convexities, long cylindrical rhizophoric axes might be developed. The resulting plant would agree with *Lepidodendron* or *Sigillaria* in the possession of a cylindrical main stem with a system of diverging root-like organs forming a stigmarian base.

Such comparisons must of course be speculative but they are justified by the close and detailed resemblances in the root-scars and root-insertions, in the structure of the roots, and the orientation of their structure towards the growing region in *Isoëtes* to the corresponding feature in the *Lepidodendreae*. The root bearing basal region of the latter requires morphological explanation. Unfortunately we have no knowledge of its development nor indeed of the structure of the basal portion of the plant at the junction between stem and rhizophoric region.

¹² Superficial comparisons are so often made between the lobing of the stock of *Isoëtes* and the lobes of the root-bearing base of *Pleuromeia* or the *Lepidodendreae*, that it may be well to emphasise the fact that such comparisons are erroneous. It is the *grooves* of the *Isoëtes* stock, beneath which the lobes of the rhizophoric stele lie, that correspond morphologically to the *lobes* of *Pleuromeia*.

These facts are available in the case of *Isoëtes* and the study of this existing plant affords at least a chance of further insight into the morphology of *Stigmaria*. On this view the rhizophoric base of *Isoëtes* appears to be the most directly comparable structure in recent plants to the basal root-bearing region of the Lepidophytinæ and should hold a prominent position in any discussion of the morphology of this.

The general view of the morphology of the stock of *Isoëtes* reached by this preliminary enquiry is briefly that it consists of a shoot-region and a rhizophoric-region. The origin of the rhizophore may perhaps stand in some relation to the deep-seated secondary meristem at the base of the shoot. Once initiated, however, the growing region of the rhizophore behaves like a primary apex which is congenitally sunken and enclosed. This apex is extended as a line in two-lobed forms and in three or four directions in three or four-lobed stocks. It gives rise to roots in acropetal order, and these when mature stand exogenously on the surface, which is exposed by the split. On this general view (which allows for the conflicting facts emphasised in Von Mohl's and Hofmeister's explanations respectively, and confirms Williamson's comparison with the organisation of the Lepidodendreæ) some details of the stock of *Isoëtes* may be fruitfully re-investigated in later papers.

IV. Variation in a Carboniferous Brachiopod—
Reticularia lineata (Martin).

By HENRY DAY, B.Sc.,

Geological Department, The University, Manchester.

(Read November 3rd, 1914. Received for publication, December 22nd, 1914.)

The shell dealt with in this paper is undoubtedly the *Conchylolithus anomites* (*lineatus*) of Martin, as it agrees in every detail with his description and figure (*Petrificata Derbiensia, Pl. 36, Fig. 3*). He speaks of it as "common in limestone, particularly near Castleton," and it is of interest to note that my own specimens came from the same neighbourhood.

Davidson ("British Fossil Brachiopoda," Vol. II., Pt. V., p. 62) describes the species under "*Spirifera lineata*, Martin," with a list of synonyms. He distinguishes two principal varieties—*lineata* and *elliptica*, but on a later page (p. 226) he expresses some doubt as to *S. elliptica* being correctly placed among the varieties of *lineata*. Davidson gives a reproduction, though not a very accurate one, of Martin's original figure (*op. cit.*), and in his description of the first variety (*lineata*) he considers *S. imbricata*, Sow., *S. Martini*, Fleming, and *S. reticulata*, McCoy, as synonymous with Martin's species, but certainly the *S. reticulata* of McCoy, with its strong mesial sinus, can scarcely be accepted as being the same species as *lineata*.

The specimens exhibit the reticulation of *S. lineata*, so well described by Davidson (*op. cit.*, p. 225), and also

February 11th, 1915.

possess the parallel dental lamellæ which, together with the reticulation, characterise McCoy's genus, *Reticularia*. (A Synopsis of the characters of the Carboniferous Limestone Fossils of Ireland, 1844, p. 143, and Pl. XIX., Fig. 15.) An enlarged view of the characteristic reticulate ornament is given on *Pl. I, L*.

The whole question of the genetic relationships of the Carboniferous Spiriferids is obscured by a complicated synonymy, but still more so, as Buckman has shown ("Brachiopod Homœomorphy": "*Spirifer glaber*," *Q.J.G.S.*, 1908) by heterogenetic homœomorphy.

He shows, for example, that the "species" *Spirifer glaber* is really a group name, and that under it several different species and even genera have been included, which have attained their very similar smooth appearance "by the loss of different distinctive features, pointing to polygenetic origins."

It is therefore evident that a revision of the brachiopod genera of the Carboniferous is very necessary, and such revision has already entailed the institution of several genera and species out of types formerly included under one specific name. On the other hand there is always the danger of carrying this process of revision to an extreme, and needlessly instituting species upon what are merely variations.

In view of the above danger it was proposed to pursue a careful investigation into the range and character of the variation in one well-defined species of these Spiriferids, with the object of indicating what range of variation might be expected in other members of this family.

The collection of shells upon which the following results were based numbered one thousand individuals, and was made from one spot in the limestone near Peaks-hill Farm, Rushup Edge Valley, Castleton.

The collection showed remarkable variation in the form of individual shells, a variation in form which will be appreciated by a consideration of *Pl. I, A—F*, and one which, in the past, would have led in all probability to the institution of several distinct species.

On *Pl. I. A* and *B* are a pair representing the extremes of variation in breadth as compared with length. Both shells are of approximately the same length, but *A* is a very broad type and *B* is a very narrow type.

Similarly *C* and *D* are a pair representing the extremes of variation in depth, in individuals of equal breadth, *C* representing the very thick type and *D* the very thin variety, and again *E* and *F* represent the extremes of variation in depth in shells of equal length, *E* being the thick type and *F* the thin one.

The present paper gives the results of an investigation pursued with the object of ascertaining :—

1. The limits of variation.

2. The distribution of variation, *i.e.*, whether the variation was distributed normally throughout, or whether on the contrary there was a predominance of certain types of variation, indicating either, the presence of more than one species, or, the incipient splitting up of one species into two or more.

3. Any ontogenetic modification in the variations, *i.e.*, whether, during growth, there was any change in the range or distribution of the variations.

The variable character best suited for a precise investigation, was the variation in shell form, a variation indicated by the ratios $\frac{\text{Length}}{\text{Breadth}}$ and $\frac{\text{Length}}{\text{Depth}}$. For each shell the measurements length (*L*), breadth (*B*), and depth (*D*) were obtained with the micrometer calipers,

and from these measurements the required ratios were obtained.

The actual limits of variation have already been mentioned, and are indicated on *Pl. I A—F*.

To indicate the distribution of variation, distribution graphs were constructed for the ratios $\frac{L}{B}$ and $\frac{L}{D}$ (see

Fig. 1.—Curve showing the distribution of the ratio $\frac{\text{Length}}{\text{Breadth}}$ among 1000 individuals of *Reticularia lineata*.

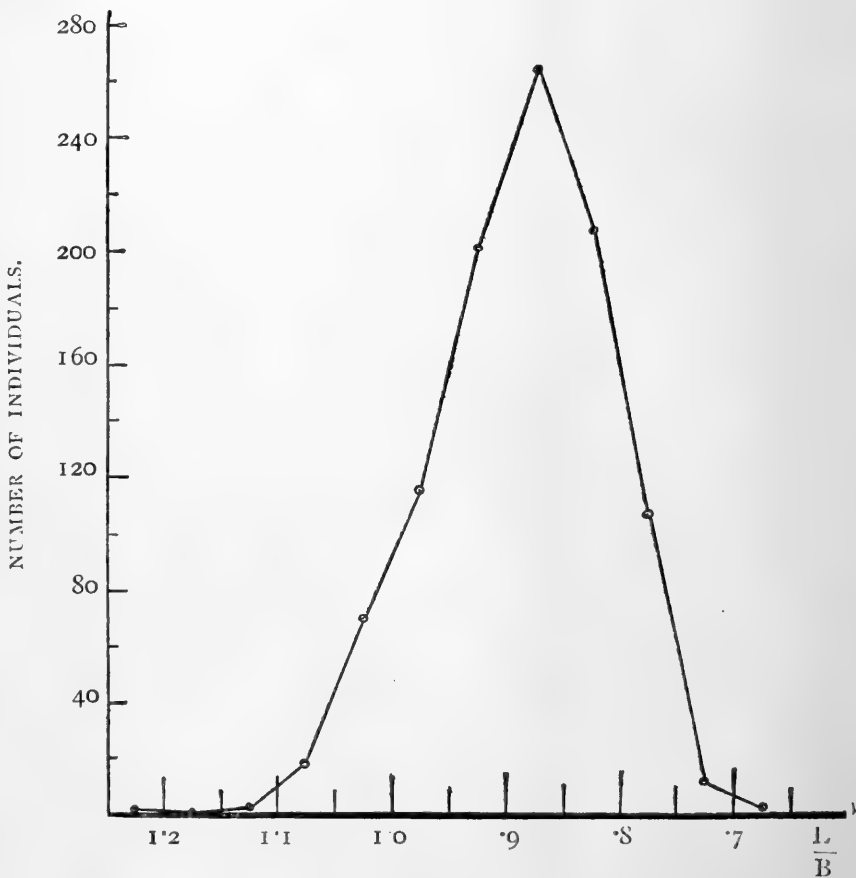

Text-figs. 1 and 2), the ratios being taken as abscissæ and numbers of individuals as ordinates.

Fig. 1 is the curve showing the distribution of $\frac{L}{B}$ among one thousand shells. The curve indicates that there is a maximum of shells possessing a mean $\frac{L}{B}$ ratio

of just over '9, and that as a departure is made from this mean in either direction, the numbers of individuals fall off so regularly that a distribution curve is produced which is remarkable for its high degree of symmetry. It is in fact a very perfect, simple "continuous variation" curve and is therefore to be accepted as proving that only one species is embraced by the collection. The curve also indicates that the species has been very constant, and has simply varied about a 'mode' which shows no indication of having moved, or of any tendency to move: in fact, whilst there is remarkable variation in shell form and also in other characters as will be noted later, yet these variations were restricted within such limits that no vital departure was made from the central type. It will be noted that in the distribution curve shells which are long and narrow are displaced to the left of the curve, and shells which are short and broad to the right.

Fig. 2 represents the distribution graph for $\frac{L}{D}$ in a thousand individuals, and may be described in almost similar terms to those applied to *Fig. 1*. We have a maximum of shells possessing, in this case, a mean $\frac{L}{D}$ ratio of about 1.65 and as a departure is made from the mean in either direction there is a very regular falling off in the numbers of individuals, producing as in the case of *Fig. 1*, a remarkably symmetrical curve, indicating as before, one species, which varied about a central type. In this case shells which are long and thin are displaced to the left of the curve, and shells which are short and thick, to the right.

The nature of the curves showing the distribution of $\frac{L}{B}$ and $\frac{L}{D}$ indicates therefore that the distribution is quite normal, varies about a central type, and gives no indica-

tion of the presence of more than one species in the collection.

ONTOGENY.—The specimens included shells in various stages of growth. Accordingly, with the object of indicating any possible ontogenetic changes, the shells were now divided into three sets according to length. The first set embraced those shells with length 0.15 to 0.45

Fig. 2.—Curve showing the distribution of the ratio $\frac{\text{Length}}{\text{Depth}}$ among 1000 individuals of *Reticularia lineata*.

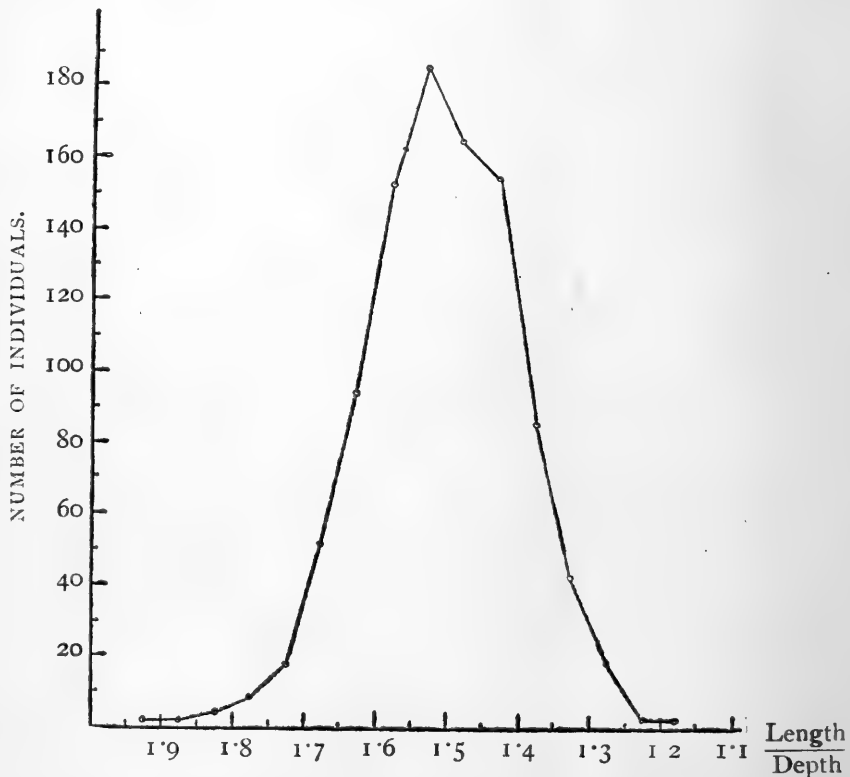

inch; the second set those shells with length 0.45 to 0.75 inch; and the third set 0.75 to 1.05 inch.

Curves were now constructed to show the distribution of $\frac{L}{B}$ and $\frac{L}{D}$ in these sets. The curves obtained for distribution of $\frac{L}{B}$ for each of the separate sets are shown in *Fig. 3*.

The three curves are simply the components of the distribution curve in *Fig. 1*. It will be seen from a consideration of *Fig. 3*, that each of the three curves is

Fig. 3.—Curves showing the distribution of the ratios $\frac{\text{Length}}{\text{Breadth}}$ among 1000 individuals of *Reticularia lineata*, the individuals being divided into three groups according to size.
 Dot-dash line = individuals with length of 0.15–0.45 inch.
 Continuous line = individuals with length of 0.45–0.75 inch.
 Broken line = individuals with length of 0.75–1.05 inch.

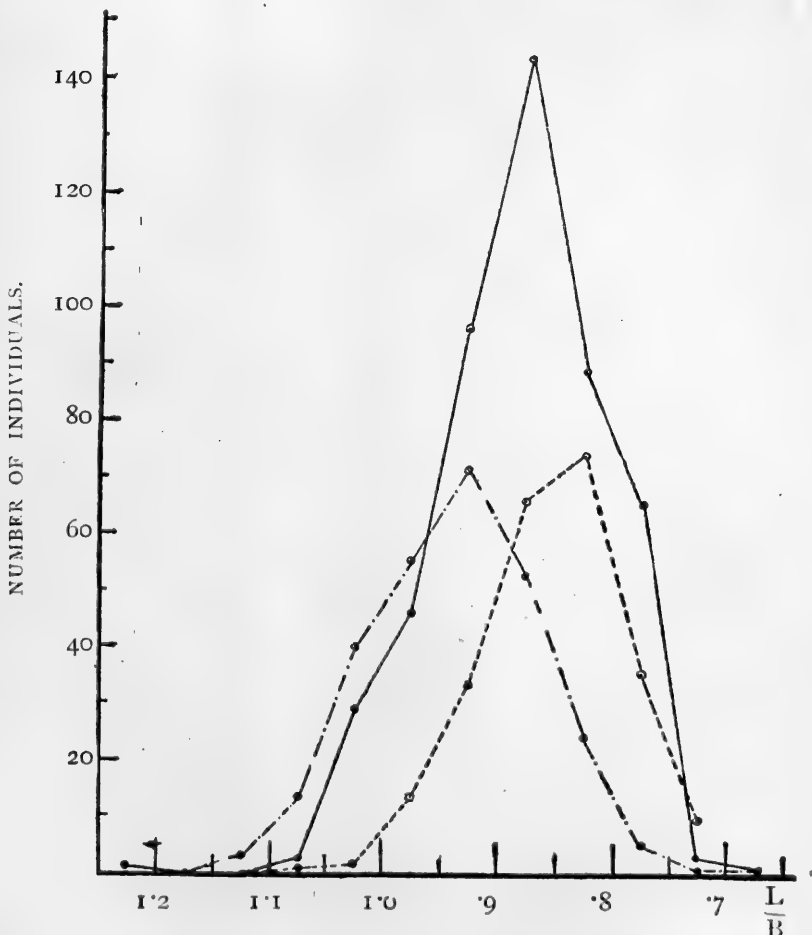

itself a very regular simple variation curve: separately therefore, each confirms the fact deduced from *Fig. 1* that one species only is under consideration.

A very interesting point is brought out by *Fig. 3* in that, as will be seen from a consideration of the figure, there is a very regular displacement of the maximum or 'mode' of the curve towards the right, with each increase in length, and this it will be observed is in the direction of decreasing $\frac{L}{B}$ ratio. Since the three curves in order from the left correspond to progressive increases in length, then we may conclude that, as the shells increased in size (*i.e.*, throughout life) there was a tendency for the value $\frac{L}{B}$ to decrease, *i.e.*, for the shell to become broader.

The curves obtained for the distribution of $\frac{L}{D}$ in the three sets are shown in *Fig. 4*, and represent the components of the distribution curve in *Fig. 2*. Here, as in the curves in *Fig. 3*, each curve is a regular simple variation curve, and we have again a displacement of the maximum or 'mode' of the curve towards the right, with each increase in length, and this it will be observed from the figure is in the direction of decreasing $\frac{L}{D}$ ratio. Since the three curves in order from the left correspond to progressively equal increases in length, then we may conclude that in this case, as the shells increased in size (*i.e.*, throughout life) there was a tendency for the value $\frac{L}{D}$ to decrease, *i.e.*, for the shell to become deeper.

From the curves in *Fig. 3*, therefore, it was found that as the shell increases in size, *i.e.*, with increasing age, the ratio value $\frac{L}{B}$ diminishes, and from those in *Fig. 4* that there is a similar decrease in the ratio value $\frac{L}{D}$. It follows therefore that both breadth and depth increase at a greater relative rate throughout life, than does the length. This coincidence must involve some degree of correlation between breadth and depth.

The existence of such a correlation was further shown in the following way. The ratios $\frac{L}{B}$ and $\frac{L}{D}$ obtained for each shell were plotted against one another $\frac{L}{B}$ ratios being

Fig. 4.—Curves showing the distribution of the ratios $\frac{\text{Length}}{\text{Depth}}$ among 1000 individuals of *Reticularia lineata*, the individuals being divided into three groups according to size.

Dot-dash line = individuals with length of 0.15—0.45 inch.
 Continuous line = individuals with length of 0.45—0.75 inch.
 Broken line = individuals with length of 0.75—1.05 inch.

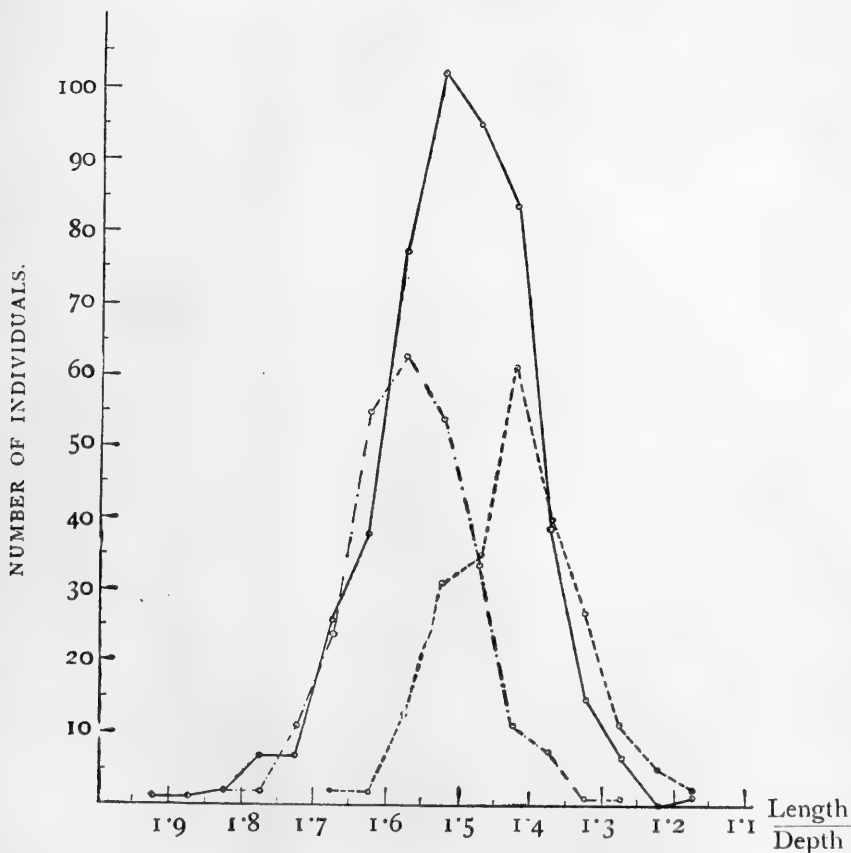

taken as abscissæ and $\frac{L}{D}$ ratios as ordinates. Each shell is thus represented on the graph by a point. The graph field was now divided up into small squares by drawing

the horizontal and vertical lines corresponding to successive equal increases in the values $\frac{L}{B}$ and $\frac{L}{D}$ of .05. Each square therefore contained a number of points, and the actual number (representing individuals) was ascertained by counting. This graph is reproduced in *Fig. 5*, where the lower number in each square represents the actual number of individuals falling within its limits.

On the same figure are shown the actual numbers of individuals possessing particular $\frac{L}{B}$ and $\frac{L}{D}$ ratios. Hence, *if there is absolutely no degree of correlation between these ratios*, it is possible to predict the chance of any individual falling within a given square of the graph. This chance is clearly the product of its chances of falling within the respective vertical and horizontal columns whose intersection forms the square.

For example (in *Fig. 5*) let us consider the horizontal row of squares *B* corresponding to the $\frac{L}{D}$ ratio interval 1.2—1.25; and the vertical column of squares *A* corresponding to the $\frac{L}{B}$ ratio interval .7—.75. We have three shells (out of 1000) possessing an $\frac{L}{D}$ ratio lying between 1.2 and 1.25, so that the chances of a shell occurring in the horizontal row of squares *B* are $\frac{3}{1000}$. Similarly in the vertical column *A* we have thirteen shells possessing an $\frac{L}{B}$ ratio lying between .7 and .75, hence the chances of a shell occurring in the vertical column of squares *A* are $\frac{13}{1000}$. It follows therefore that the chances of any shell occurring in the square common to the columns *A* and *B* are measured by the product of $\frac{3}{1000} \times \frac{13}{1000}$ or thirty-nine chances in a million (= .039 per thousand).

Fig. 5—Graph showing the relation of the $\frac{\text{Length}}{\text{Breadth}}$ and $\frac{\text{Length}}{\text{Depth}}$ ratios among 1,000 individuals of *Reticularia lineata*.

Upper figures (in italics) show the "expectation" of the number of individuals which should fall within each area, on the assumption of no correlation between the ratios.

Lower figures (in black type) show actual number of individuals falling within each area.

R OF INDIVIDUALS	A.										B.			
	.6	.7	.8	.9	1.0	1.1	1.2	1.3	2.0					
19	38 0	247 1	2052 2	3933 1	5016 10	3819 2	2204 0	1349 1	342 0	57 0	0 0	19 0		
3	6 0	39 0	324 0	621 1	792 2	603 0	348 0	213 0	54 0	9 0	0 0	3 0		
3	6 0	39 0	324 2	621 1	792 0	603 0	348 0	213 0	54 0	9 0	0 0	3 0		
1.1														

NUMBER OF INDIVIDUALS.

the horizontal and vertical lines corresponding to successive equal increases in the values $\frac{L}{B}$ and $\frac{L}{D}$ of .05. Each square therefore contained a number of points, and the actual number (representing individuals) was ascertained by counting. This graph is reproduced in *Fig. 5*, where the lower number in each square represents the actual number of individuals falling within its limits.

On the same figure are shown the actual numbers of individuals possessing particular $\frac{L}{B}$ and $\frac{L}{D}$ ratios. Hence, *if there is absolutely no degree of correlation between these ratios*, it is possible to predict the chance of any individual falling within a given square of the graph. This chance is clearly the product of its chances of falling within the respective vertical and horizontal columns whose intersection forms the square.

For example (in *Fig. 5*) let us consider the horizontal row of squares *B* corresponding to the $\frac{L}{D}$ ratio interval 1.2—1.25; and the vertical column of squares *A* corresponding to the $\frac{L}{B}$ ratio interval .7—.75. We have three shells (out of 1000) possessing an $\frac{L}{D}$ ratio lying between 1.2 and 1.25, so that the chances of a shell occurring in the horizontal row of squares *B* are $\frac{3}{1000}$. Similarly in the vertical column *A* we have thirteen shells possessing an $\frac{L}{B}$ ratio lying between .7 and .75, hence the chances of a shell occurring in the vertical column of squares *A* are $\frac{13}{1000}$. It follows therefore that the chances of any shell occurring in the square common to the columns *A* and *B* are measured by the product of $\frac{3}{1000} \times \frac{13}{1000}$ or thirty-nine chances in a million (= .039 per thousand).



Similarly the chance (*per million*) for each square was calculated, and is indicated by the upper set of numbers in *Fig. 5*.

Fig. 6.—Graph showing the relation of the $\frac{\text{Length}}{\text{Breadth}}$ and $\frac{\text{Length}}{\text{Depth}}$ ratios among 1000 individuals of *Reticularia lineata* (reduced from *Fig. 5*, q.v.).

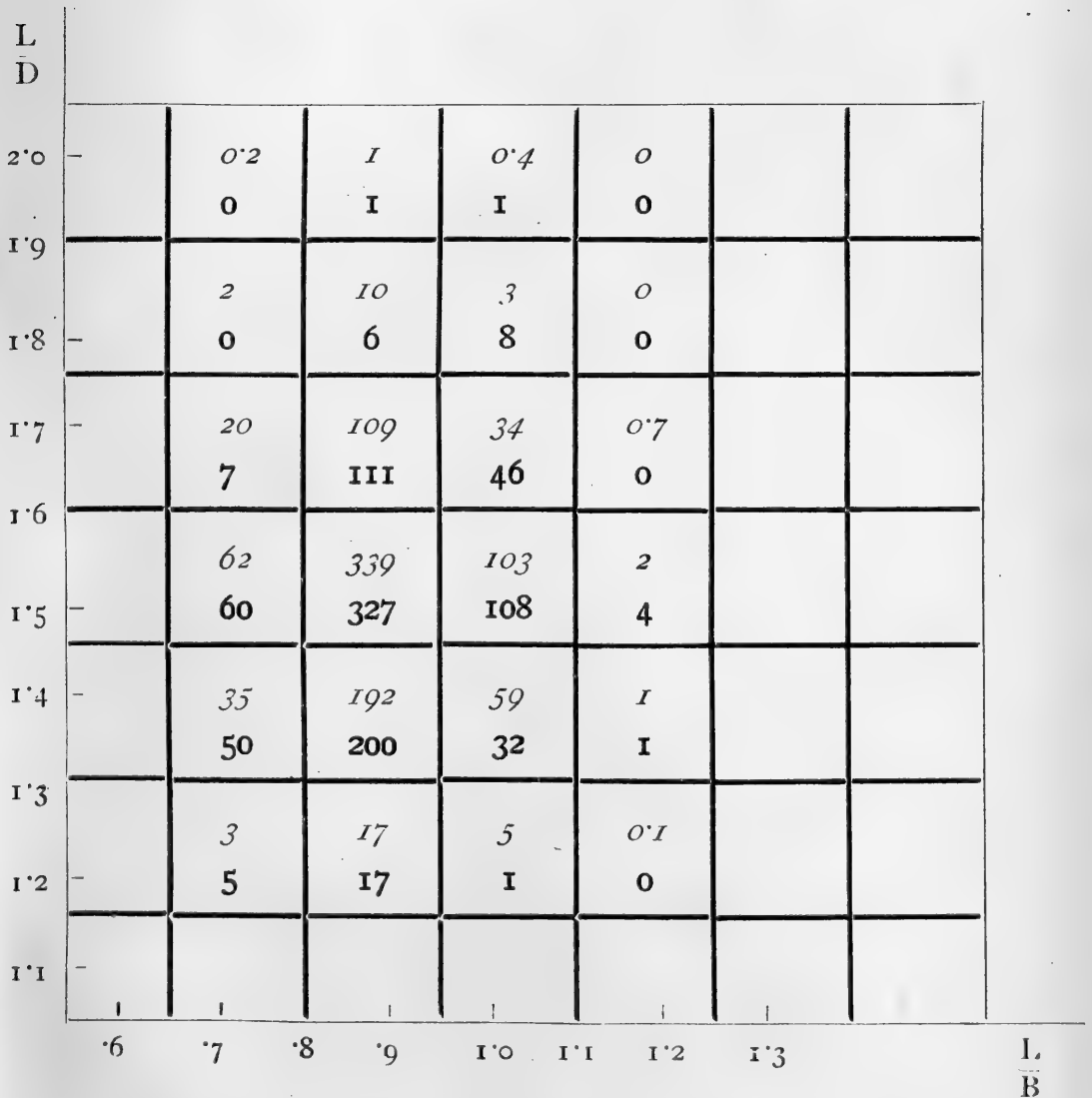

In *Fig. 5* therefore, the numbers in italics represent the theoretical chances per million of any shell falling in the squares containing them, and the numbers in black type

represent the actual numbers of shells occurring in the corresponding squares.

While the general agreement of the actual density of individuals in each square with the theoretical expectation is fairly evident, it is better seen in the condensed form of the graph represented in *Fig. 6* where the squares represent intervals of .15, in the indices (corresponding with the thickened squares in *Fig. 5*). Any *systematic* deviation of the actual numbers from the theoretical expectation will indicate a correlation between breadth and depth. The existence of such a deviation can most readily be seen by summing the numbers in quadrants as has been done in *Fig. 7*. (the theoretical expectations have here been reduced to chances per thousand, as also in *Fig. 6*, for more ready comparison with the actual numbers).

The only kind of correlation which can be reasonably expected is one in which the depth $\left(\frac{L}{D}\right)$ increases either directly or inversely as the breadth $\left(\frac{L}{B}\right)$. If such a correlation were complete the position of every individual on the graph would fall on a line passing through the modal point x .

In the case of direct correlation this line must be contained in the quadrants a, a' ; with inverse correlation it will fall in the quadrants b, b' . If such a correlation exists, but is incomplete it will be shown by a concentration of the individuals towards such a line, resulting in a concentration in the pair of quadrants in which the line falls. The degree of this concentration is clearly a measure of the correlation, and may be expressed as

$$\frac{(a + a') - (b + b')}{(a + a') + (b + b')}$$

In this case we have

$$\frac{(308.5 + 287) - (144 + 245.5)}{(308.5 + 287) + (144 + 245.5)} = \frac{206}{985} = .21$$

Since the concentration is along the line $a—a'$ we see that there is some degree of *direct* correlation; *i.e.*, when the value of $\frac{L}{D}$ is low, the value of $\frac{L}{B}$ tends to be low, and *vice versa*. We see further that the value of this

Fig. 7.—Graph showing the relation of the $\frac{\text{Length}}{\text{Breadth}}$ and $\frac{\text{Length}}{\text{Depth}}$ ratios among 1000 individuals of *Reticularia lineata* (reduced from Fig. 5, q.v.).

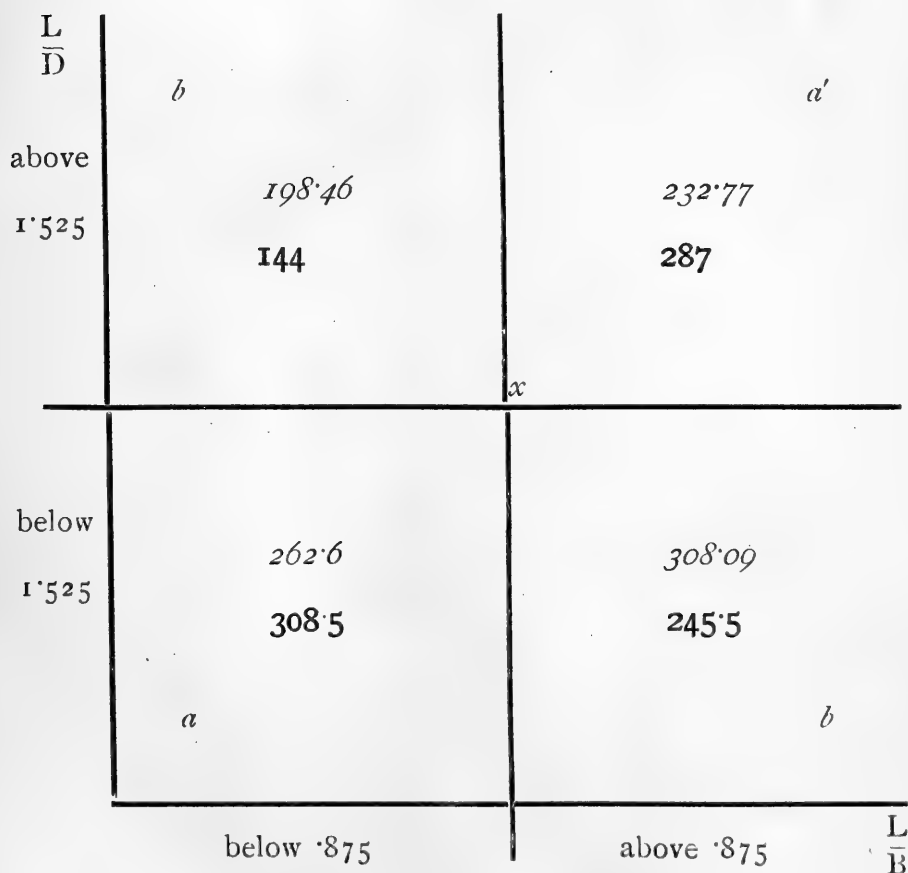

correlation is .21, when complete correlation would be represented by unity. In other words, this may be expressed by saying that of the whole variation one-fifth is strictly correlated and four-fifths are uncorrelated.

Now we have already seen that some correlation must exist, since the two ratios, $\frac{L}{B}$ and $\frac{L}{D}$, both decrease as the shell grows in size. This change may be shown to be an inevitable result of the form of curvature of the valves—a form common to nearly all bivalve shells. Referring back to the curves in *Fig. 4*, we see that the mean value of the $\frac{L}{D}$ ratio diminishes from 1.575 in the smallest shells to 1.425 in the largest, while the total range of variation is from 1.175 to 1.925. That is, out of a total range of .75, exactly one-fifth (.15) is due to change of form during growth. Similarly reference to *Fig. 3* shows that the mean value of the ratio $\frac{L}{B}$ diminishes from .925 to .825, representing a change of .1 out of a total variation from .675 to 1.225. Again, the variation due to growth change is very nearly one-fifth of the total. It is obvious that these changes in the $\frac{L}{D}$ and $\frac{L}{B}$ ratios which occur during growth must be perfectly correlated.

But we have seen that the extent of the correlation of these ratios is one-fifth of their whole amount. Thus we find that the existing correlation is just such as would be anticipated from the growth changes, and we may therefore confidently assume that, apart from this, *the variations in breadth and depth occur quite independently of one another.*

OTHER VARIABLE CHARACTERS IN THE SHELLS.

I. *Variation in size of the Beak of Ventral Valve.*

There is a striking variation to be observed in the size of the beak of the ventral valve relative to that of the dorsal valve. Some shells exhibit an umbonal region in which the two beaks are practically equal in size, and from these at the one extreme there is every gradation

to those at the other extreme, in which the ventral beak is remarkably large and prominent as compared with that of the dorsal valve. This feature of variation is illustrated by the pair of extremes *J* and *K*, *Pl. I.*

Upon sorting the shells into groups representing those with equal beaks, those with very unequal beaks, and those with beaks representing the mean between the extremes, no definite correlation was to be observed between this feature of variation and any other shell character.

2. Lateral Twisting of the Ventral Beak.

This remarkable feature of twisting of the ventral beak might readily have been overlooked in the handling of a few individuals, as merely a chance variation, and only became evident as a regular feature of variation upon an examination of the shells as a body, when the large number of individuals possessing this feature became very evident, the asymmetry produced in some cases being very appreciable.

Still more remarkable is the fact that twisting takes place, in some individuals to the right, in others to the left, with a greater proportion of left-twisted forms. The asymmetry produced, affects not only the umbonal region but also the form of the shell as a whole.

On *Pl. I.*, *H* represents the symmetrical type, whilst *G* and *I* represent extremes of twisting to left and right respectively, and between the mean and the extreme on either side there are shells showing almost imperceptible gradations in the amount of twisting to right or left.

3. Ornament of Shell.

The ornament of this species of *Reticularia*, following the characters of the genotype is reticulate, but there is

some variation in the strength of the reticulation, since, as Buckman has pointed out, the genus is in the catagenetic stages leading towards ultimate smoothness. The ornament of the present species has been described and figured by Davidson ("British Fossil Brachiopoda," Vol. II., Pt. V., p. 225, and Pl. LI., fig. 15). He says "externally the surface was covered with numerous concentric ridges, rarely in any place more than a line apart, but usually very much closer, and from each of which projected numerous, closely packed spines, which thus formed a series of spiny fringes overlaying each other all over the shell."

Very few individuals in the present collection have retained the external skin of the shell, so as to show the well-developed reticulation, but in practically all cases where the skin is lost, the ornament has become impressed on the test beneath, and is still clearly reticulate. *Pl. I., L.*, is an enlarged photograph of the outer skin of the test in one very good example, and shows the remarkable character of the ornament.

The impressing of the surface reticulation on the test beneath, in the present species, is in marked contrast to the features I have observed in other closely similar *Reticulariæ*. In these the surface ornament is, as usual, reticulate by combination of radial and concentric ornament, but in places where the outer skin has peeled off, only a very strong radial ribbing is to be seen, with no reticulation visible. This radial ribbing represents, presumably, a dominant radial ornament impressed on the test beneath, but in any case, the fact that such an entirely different ornament underlies the true surface ornament, might well lead to the institution of new genera, on what are, in reality, specimens of well-known forms which have lost the outer skin of the test.

4. *Marginal Notching of the Valves.*

In collecting the present shells it was found that some individuals showed curious notches or incisions on the margins of the valves. About fifty individuals were found possessing this peculiarity, this working out at five per cent. of the shells obtained. Shells in all stages of growth are represented among the fifty individuals, but in no case does the notch, or the evidence of a notch—as shown by a narrow sinus on the shell—extend quite up to the umbo—*i.e.*, the notch was not present in the very young shell. Certain shells have only one notch, whilst others possess two. When one notch only is present, there is considerable variation in its position. Much the commonest type is that in which the notch is to the left-hand side of the median line (viewed dorsally). In a very few cases the notch is on the anterior margin of the valves, exactly opposite the umbo; in a few cases, again, the notch is to the right of the median line, and in three shells there are two notches.

The origin of these notches is obscure, but they are probably due to some injury to the mantles of the individuals in which they are developed, an injury possibly caused by some parasitic organism.

A similar feature is to be seen occasionally in several living species of Brachiopods, *e.g.*, *Magellania venosa* and *Magellania fragilis*, and in these cases is probably due to a similar cause, hence by examination of such living types it might be possible to determine the factor producing this curious deformation.

DESCRIPTION OF PLATE I.

(All photographs are $\frac{5}{8}$ ths nat. size except *L.*)

- A* and *B.*—Pair of shells representing the extremes of variation in breadth, in shells of equal length.
- C* and *D.*—Pair of shells representing the extremes of variation in depth, in individuals of equal breadth.
- E* and *F.*—Pair of shells representing the extremes of variation in depth, in shells of equal length.
- G*, *H*, and *I.*—Shells illustrating the twisting of the ventral beak. N.B.—Each shell was placed with the hinge line strictly horizontal.
- J* and *K.*—Pair of shells illustrating the extremes of variation in the relative size of the ventral beak.
- L.*—Microphotograph of the surface ornament. $\times 6.3$ diams.

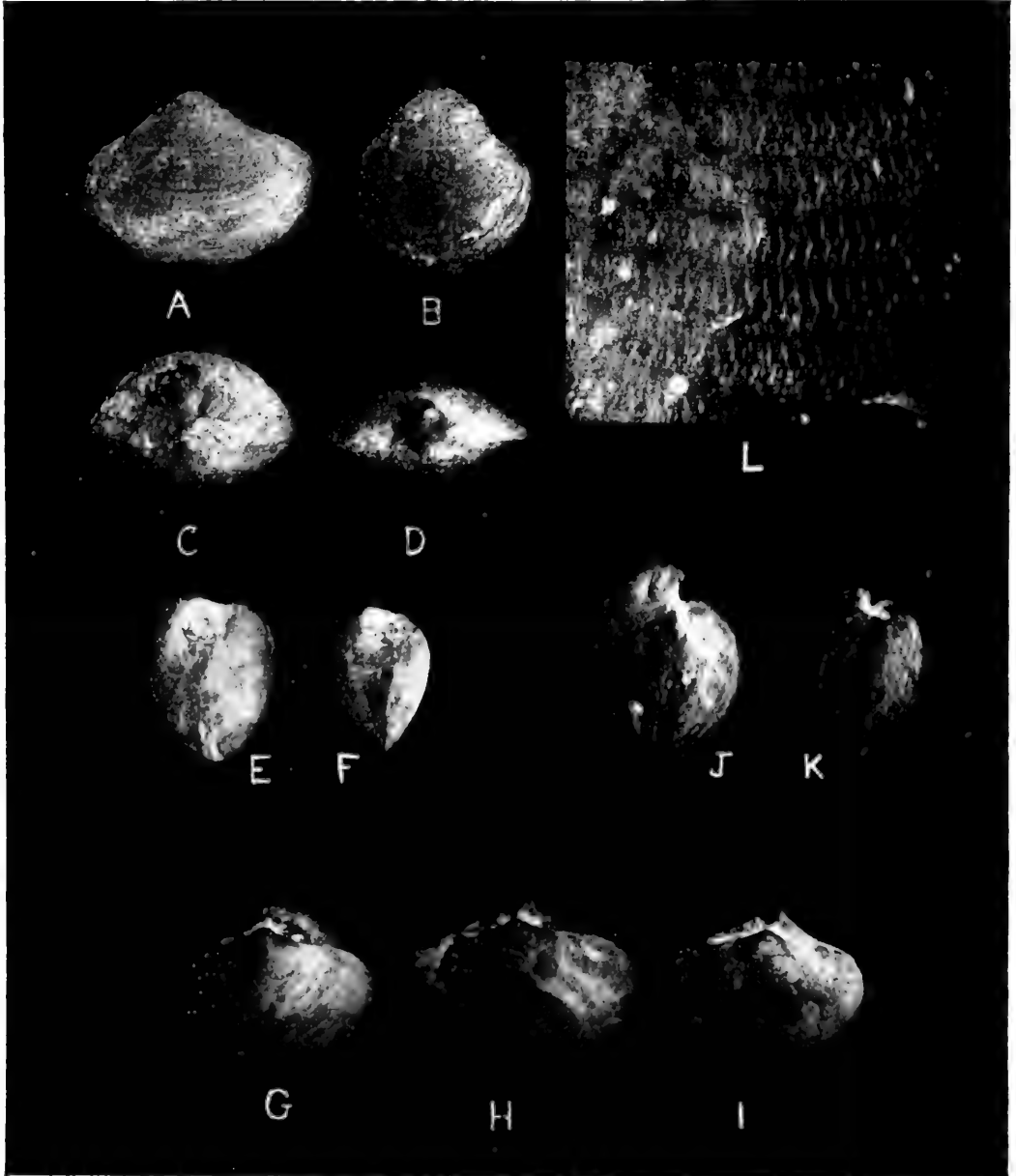



V. Note on Foggy Days in Manchester.

By WILLIAM C. JENKINS, F.R.A.S.

(Received and Read January 26th, 1915.)

For some considerable time past numerous enquirers have frequently made the statement, "that Manchester of to-day was much less smoky than in years past." To confirm my own opposite opinion I have collected and compared in tabular form the number of days on which fog has prevailed during the ten years 1904-13 inclusive.

A distinction was made in this tabulation, by separating the days on which fog prevailed in the ordinary

TABLE I.
MONTHLY AVERAGES OF FOGGY AND GLOOMY DAYS.

Month.	—Period 1904-13.—			1904-7.	1910-13.
	Fog.	Days of Gloom.	Fog and Gloom.	Fog and Gloom.	Fog and Gloom.
January	5·6	1·2	6·2	3·8	7·5
February	3·9	0·8	4·2	3·3	4·5
March	3·5	1·0	4·2	3·5	4·3
April	1·4	1·1	2·5	0·5	3·8
May	0·9	0·9	1·8	0·8	3·3
June	0·2	0·9	1·1	—	1·0
July	0·4	0·9	1·3	0·5	2·5
August	1·5	0·8	2·2	0·5	3·0
September	3·3	0·5	3·8	3·0	5·0
October	4·4	0·5	4·9	4·8	5·5
November	7·3	1·6	7·8	7·5	7·0
December	5·3	1·0	5·7	6·0	4·5

sense of the term, as a mist overlying the earth and obscuring the distant vision from those on which dark-

March 9th, 1915.

ness prevailed with clear horizontal vision, caused by the suspension of smoke at a very low altitude, these I call Gloom days.

In Table I. the monthly averages are given in column 2 for fog only, column 3 gloom only, column 4 fog and gloom combined, column 5 gives the combined figures for the years 1904-7, and in column 6 for 1910-13.

In this way we are able to see at a glance the increased numbers in the period 1910-13 as compared with the years 1904-7, the average being 30 % increase.

Making a diagram of these it is evident that the position of the heavy continuous line representing the figures for the years 1910-13 is above the average, and the opposite in 1904-7 except for the months of November and December.

This brings me to a re-arrangement of the figures

TABLE II.
ANNUAL AND SEASONAL DISTRIBUTION OF FOGGY
AND GLOOMY DAYS.

Year.	Total Annual.		Oct. to March.		Apl. to Sept.	
	Foggy.	Gloomy.	Foggy.	Gloomy.	Foggy.	Gloomy.
1904 ...	34	10	30	8	4	2
1905 ...	24	7	24	5	—	2
1906 ...	26	5	24	5	2	—
1907 ...	35	6	28	2	7	4
1908 ...	42	8	35	3	7	5
1909 ...	58	16	44	10	14	6
1910 ...	42	15	27	6	15	9
1911 ...	32	11	26	7	6	4
1912 ...	37	11	30	9	7	2
1913 ...	48	25	32	8	16	17

according to season. In Table II. is given the Annual and Seasonal Distribution of Foggy and Gloomy Days

From this table it is quite apparent that the Annual

Total number of days on which Fog and Gloom prevail is steadily increasing, the most marked advance is in the number of days affected by gloom, the increase being 100%. Gloom prevails on days of very little wind, the smoke cloud accumulates locally during the hours when house and office fires are being lighted and before they are burning brightly, the greater number of glooms occur about 10-30 a.m

As a further confirmation of the increase in the smokiness of the local atmosphere, I have made some comparisons of the values of sunlight at two points on and about 100 feet above the ground. These show a loss by various methods of about 10%.

A comparison of the record by the Campbell Stokes sunshine recorder at the School of Technology 100 feet above ground with those published for the Oldham Road station of the Medical Officer of Health supports the increase of obstruction to the free passage of sunlight.

TABLE III.
COMPARISON OF MANCHESTER RECORDS OF BRIGHT SUNSHINE.

Year.	Godlee Observatory.	Oldham Road.	G. O.--O. R.	% of G. O.
1906	1149	1144	+ 5	0.4
1907	1028	942	+ 86	8.4
1908	1162	991	+ 171	14.7
1909	1148	999	+ 149	13.0
1910	1106	982	+ 124	11.2
1911	1431	1284	+ 147	10.3
1912	965	779	+ 186	19.3
1913	1033	883	+ 150	14.5

Here again the loss during the years 1908-9 corresponds with the increase of fog and gloom in those years, as otherwise the loss is a steadily increasing amount.

COMPARISON OF THE AVERAGE NUMBER OF DAYS PER MONTH
ON WHICH FOG OR GLOOM WERE NOTED.

—————

The Average for the 10 years 1904-13 is shown

 " " 4 " 1904-7 " - - - - -

 " " 4 " 1910-13 " —————

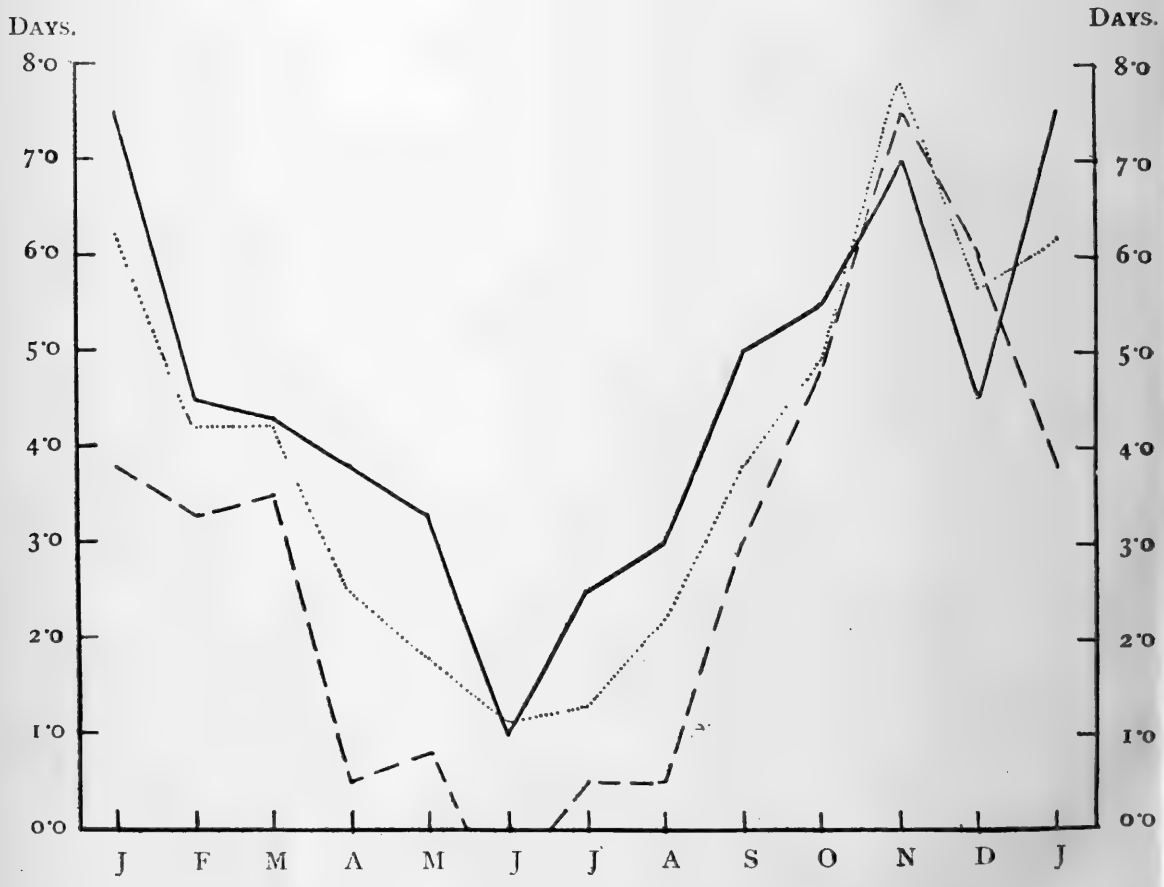

VI. Note on the Monthly Variation of Sunshine.

By Professor W. W. HALDANE GEE, B.Sc., M.Sc.Tech.

(Read January 26th, 1915. Received for publication, January 29th, 1915.)

In connection with the work of the Air Pollution Advisory Board of the Manchester City Council, I have examined the records of the Sunshine taken with the Campbell-Stokes glass sphere, which concentrates the sun's rays and gives a charred trace on a graduated card placed at the focus of the sphere. These records have been obtained at a number of stations for many years. I find that by averaging the figures over a number of years, the percentage of hours of sunshine, calculated on the number of hours from sunrise to sunset, reaches a maximum value in the month of May. I am not aware if this has been previously noted. It is clearly shown graphically in the *Figs. 1* and *2*.¹ All these exhibit a maximum in May and a lower one in August.

That it is not a coincidence for these years is shown by an inspection of *Fig. 3*, which applies to Stonyhurst for the 33 years from 1880 to 1912.²

The observations made at the Godlee Observatory by Mr. Jenkins for 1906-1910 (see *Fig. 4*) show the same law, but not in so marked a manner.

It cannot be expected that each year will follow the rule. It is followed for the year 1910 for a number of stations, as shown in *Fig. 5*, but in 1911 the maximum value is either in July or in August.

Sunlight in May must have a powerful influence on

¹ From the records given by R. H. Scott, *Quarterly Journal Royal Meteorological Society*, p. 205, vol. xi., 1885.

² From results of observations at Stonyhurst by the Rev. W. Sidgreaves, 1913.

vital development which Naturalists tell us is noteworthy in this month. The word "May" is itself supposed by some to be derived from Maia, the goddess of increase or growth.

May and May-Day have always been favourite themes with poets. Milton, Heine and Tennyson have, for example, given us well-known poems or sonnets. May-Day was celebrated in ancient times with much rejoicing. On the occasion of one of these Mayings we are told that "the Aldermen and Sheriffes of London had a worshipping dinner for themselves and other commers." Lydgate, the poet-monk, sent a joyful commendation of the season of "sixteen staves in meeter royall" which commenced :

" Mighty Flora, goddesse of fresh flowers
Which clothed hath the soyle in lusty greene,
Made buds to spring with her sweet showers
By influence of the sunne shine."

Other poets note the influence of the sun. Perhaps, then, our "May flowers" may be due in no unimportant degree to May sunshine, and not only to the "April showers" of the well-known saying.

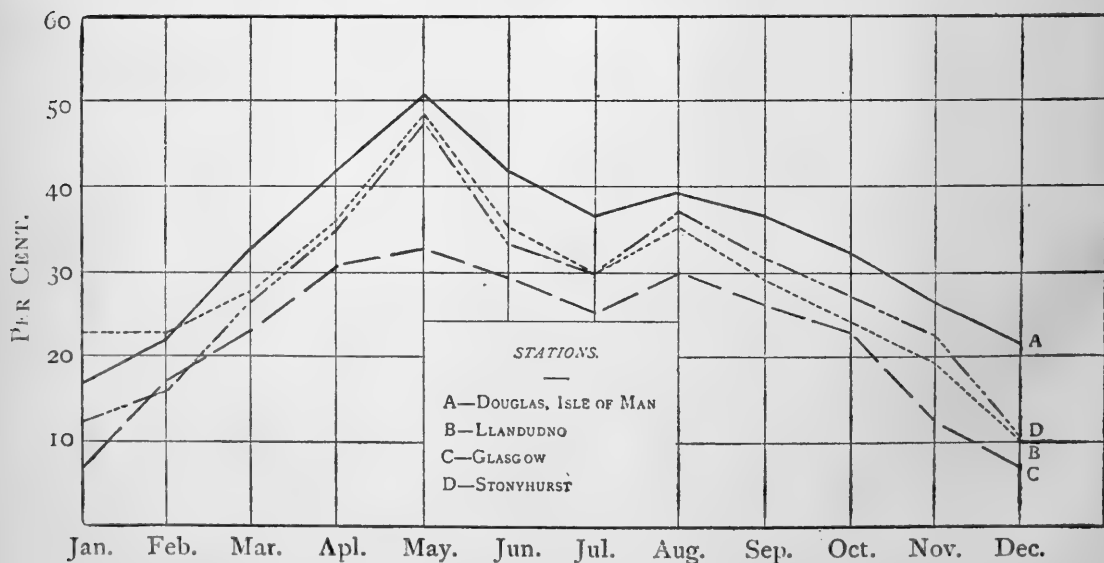

Fig. 1. Curves Showing the Average Percentage of Possible Duration of Bright Sunshine during the Years 1880-1885.

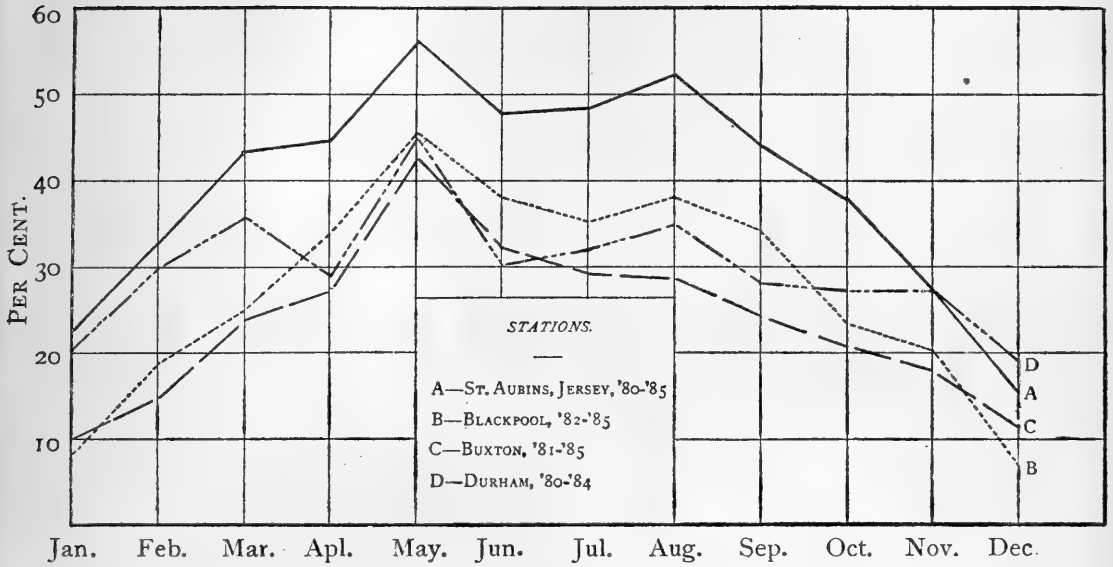

Fig. 2.

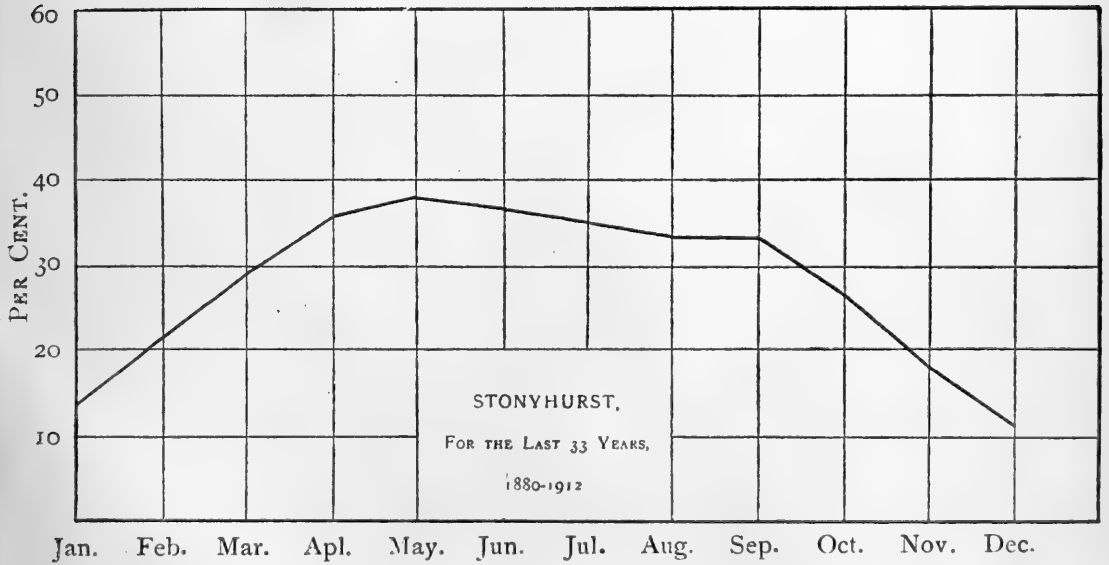

Fig. 3.

4 GEE, *Note on the Monthly Variation of Sunshine.*

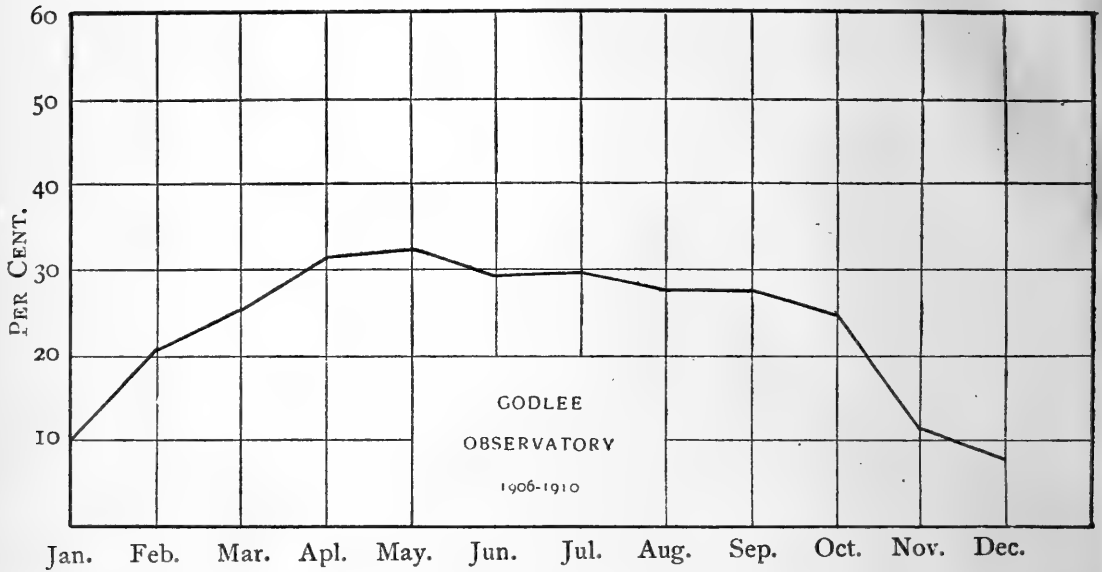

Fig. 4.

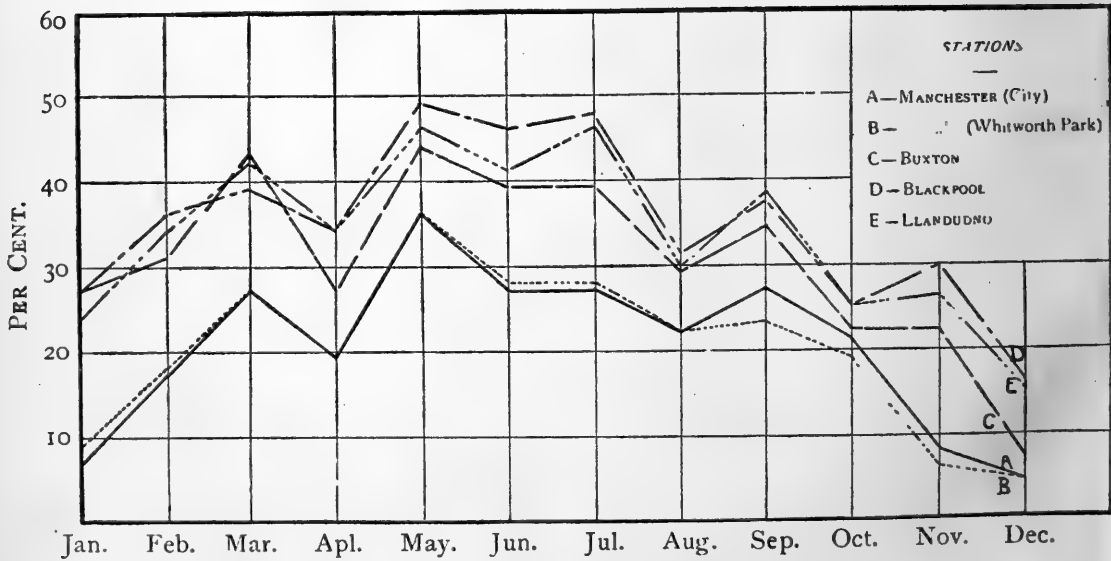

Fig. 5. Observations for 1910.

RECENT ADDITIONS TO THE LIBRARY.—*Continued.*

Urbana.—Illinois State Geological Survey. The Mississippian Brachiopoda of the Mississippi Valley Basin. By Stuart Weller. [Text and Plates.] (Monograph 1.) Urbana, Ill., 1914. (*Recd.* 30/i./15.)

—.—**Illinois State Laboratory of Natural History.** Fresh Water Fishes and their Ecology. By S. A. Forbes. n.p., 1914. (*Recd.* 14/xii./14.)

Washington.—United States Coast and Geodetic Survey. Results of Magnetic Observations made by the United States Coast and Geodetic Survey in 1913. By R. L. Faris. (Special Publication, No. 20.) Washington, 1914. (*Recd.* 2/xii./14.)

—.— — Results of Observations made by the United States Coast and Geodetic Survey...Tueson, 1911 and 1912. By D. L. Hazard. Washington, 1914. (*Recd.* 14/i./15.)

—.— — Results of Observations made...United States Coast and Geodetic Survey...Vieques, Porto Rico, 1911 and 1912. By D. L. Hazard. Washington, 1914. (*Recd.* 2/xii./14.)

Purchased.

London.—Entomologist, The. Vols. 2-10. London, 1864-1877. (*Recd.* 2/xi./14.)

—.—**Ray Society.** The British Marine Annelids. Vol. III., Part I., Text. Polychaeta. By W. C. McIntosh. London, 1915. (*Recd.* 9/ii./15.)

New Exchanges.

The Radcliffe Library, Oxford, and the Bureau of the Annual International Tables of Constants and Numerical Data, Liverpool, have been placed on the List of Institutions to which the Society's publications are presented.

And the usual Exchanges and Periodicals.

MEMOIRS AND PROCEEDINGS
OF
THE MANCHESTER
LITERARY & PHILOSOPHICAL
SOCIETY, 1914-1915

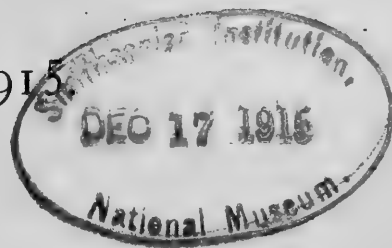

CONTENTS.

Memoirs:

- VII. A Note on the Behaviour of a Blackbird—a Problem in Mental Development. By T. A. Coward, F.Z.S., F.E.S. pp. 1—8.
(Issued separately, April 30th, 1915.)

- VIII. Studies in the Morphology of *Isoëtes*. II. The Analysis of the Stele of the Shoot of *Isoëtes lacustris* in the light of Mature Structure and Apical Development. By Professor W. H. Lang, M.B., D.Sc., F.R.S. With 4 Pls. and 1 Text-fig. - pp. 29—56.
(Pages and illustrations are numbered to follow Part I. of this series.)
(Issued separately, May 31st, 1915.)

- IX. On two cases of Parallelism in the Aphidæ. By A. W. Rymer Roberts, M.A. With 1 Pl. and 4 Text-figs. - - - pp. 1—12
(Issued separately, June 7th, 1915.)

- X. On the Significance of the Geographical Distribution of the Practice of Mummification.—A Study of the Migrations of Peoples and the Spread of certain Customs and Beliefs. By Professor G. Elliot Smith, M.A., M.D., F.R.S. With 2 Maps - - - - - pp. 1—143.
(Issued separately, July 7th, 1915.)

MANCHESTER:
36, GEORGE STREET.

Price Four Shillings.

RECENT ADDITIONS TO THE LIBRARY.

Presented.

- Gillespie (W. H.).** The Life and Teaching of William Honyman Gillespie...By James Urquhart. Edinburgh, 1915. (*Recd. 13/iv./15.*)
- London.—Humanitarian League.** Killing for Sport. Essays by various writers. London, 1915. (*Recd. 24/iv./15.*)
- Manchester.—Manchester Museum.** The Stela of Sebek-khu...By T. E. Peet. (Publication No. 75.) Manchester, 1914. (*Recd. 7/iv./15.*)
- .— **Sanitary Committee.** Report of the Sanitary Committee on the Subject of Air Pollution. [Manchester.], 1915. (*Recd. 21/v./15.*)
- New Haven.—Yale University Library.—**The Earliest Lives of Dante. Trans. from the Italian by J. R. Smith. (Yale Studies in English, X.) New York, 1901. (*Recd. 9/vi./15.*)
- .— ——— Essays on Milton. By E. N. S. Thompson. New Haven, etc., 1914. (*Recd. 9/vi./15.*)
- Washington.—United States Coast and Geodetic Survey.** Primary Triangular on the 104th Meridian...By William Bowie. (Special Publication, No. 19.) Washington, D.C., 1914. (*Recd. 9/iv./15.*)
- .— ——— Precise Levelling from Brigham, Utah, to San Francisco. By William Bowie. (Special Publication, No. 22.) Washington, D.C., 1914. (*Recd. 12/iv./15.*)
- .— **United States Geological Survey.** Geologic Atlas of the United States. Folios Nos. 190-194. Washington, D.C., 1913-14. (*Recd. 17/v./15.*)

Purchased.

- London.—Royal Society.** Catalogue of Scientific Papers, Fourth Series (1884-1900).
Vol. XIII., A—B.
Vol. XIV., C—FITTING.
• Cambridge, 1914 and 1915. (*Recd. 12/v./15.*)
- Thiselton-Dyer (W. T.).** Flora Capensis. Vol. V., Section II., Part I. London, 1915. (*Recd. 6/v./15.*)

And the usual Exchanges and Periodicals.

VII. A Note on the behaviour of a Blackbird—
a problem in Mental Development.

By T. A. COWARD, F.Z.S., F.E.S.

(Received and read March 23rd, 1915.)

In presenting the following note on the behaviour of a Blackbird, *Turdus merula* Linn., and the psychological phenomenon suggested by its action, I have no desire to enter into the controversy between the champions of Reason and Instinct. I have failed to find any hard and fast generic or specific line between animals whose actions are undoubtedly due to what we term instinct and those whose brain power is sufficiently developed to suggest glimmerings of reason. As in human beings so in the lower animals we find superior and inferior powers in individuals; one may rise above and another fall below the normal specific standard.

On February 12th, about the time when blackbirds in this neighbourhood resumed their songs, a cock bird, roused by the nuptial spirit of rivalry, began a series of assaults upon its own reflection in the glass of my scullery window. Practically every day since then the attacks have been repeated, most vigorously in the early morning but occasionally during the afternoon. Last spring a cock blackbird, presumably the same bird, continued similar attacks throughout the nesting season, even after many young birds of the same species had left their nests.

Outside the scullery is a passage, three or four yards wide, bounded by a wall, and from the top of this wall a clear reflection is visible in the glass; the reflection is

April 30th, 1915.

apparently distinct because immediately behind the window, within the scullery, is a second window giving light to a china-closet.

Each morning the blackbird flies on to the wall, then uttering a chuckling challenge hurls itself across the passage and strikes the window with a distinct thud. At the impact it flutters down perhaps a foot, but speedily regains its equilibrium and returns to the wall. It will repeat the attacks every few seconds for several minutes, and then fly off to some other part of the garden, as a rule, however, returning for further fights several times during the morning.

Similar instances of birds, especially blackbirds, fighting with their own images have been recorded. My friend, Mr. C. B. Moffat, refers to the habit in his interesting article on "The Spring Rivalry of Birds," published in the *Irish Naturalist*.* He quotes his instances to prove the "violent objection cock birds have in spring to the mere presence of other cock birds of their own species in certain spots." He was particularly fortunate in having two birds under observation at the same time. For three springs in succession a blackbird attacked one window of a house, and for two of these springs a cock chaffinch battered himself against a window on the opposite side of the house, and continued doing this the spring after the blackbird had vanished. He points out that neither blackbird nor chaffinch ever attempted to fight with themselves in any other window than the one first attacked, though presumably the reflection was equally clear on either side of the house; the blackbird's nest, and consequently its sphere of influence, was on one side and that of the chaffinch on the other.

* 1903. Pp. 155—157.

In 1906 an instance of a blackbird fighting its reflection in a cellar window of a house in Knutsford, Cheshire, came under my notice. In this case the bird behaved rather differently from mine and Mr. Moffat's; it did not fly against the window, but slipped between the bars which guarded it and, standing on the sill, battled with its reflection.

This "sphere of influence," well known to ornithologists, is usually only dominated by the male bird during the period of sexual excitement, commonly termed, the breeding season. The male bird in most species defends the immediate neighbourhood of his mate's nest against any possible rival for her affections. The area of the sphere varies according to the sociability of the species and to the pugnacity of the individual. In the case of species which are gregarious during the breeding season—the rook for example—the nest and its contents alone are defended, but in solitary species, such as the mistle thrush, the area is much greater. The mistle thrush will not only attack and drive away others of its kind, but it will assault any bird or mammal, including man, which approaches the nest; presumably the mistle thrush imagines that any intruder on its domain may have sinister designs.

The blackbird, so far as I have observed, confines its attention mainly to rival cock blackbirds, but it will mob with threatening cries any cat, owl or other predatory creature that may approach. The sphere of influence of the particular blackbird under consideration was evidently mapped out by the bird before the nest was built, and even before there was evidence that a mate had been selected and secured.

That a bird filled with the martial spirit of spring rivalry should imagine that its own reflection in a mirror

is a rival is, of course, not strange; many animals fail to recognise themselves or rather their images when confronted with a looking-glass. No doubt it was mere accident that first led my blackbird to the spot on the wall from which it could see this imaginary foe. It is the psychology of the habit, for habit it certainly is of individuals, which is so puzzling. We have a problem in mental development—brain power—in an animal whose mental scope we cannot gauge. Looking at mental power from the purely human standpoint we can hardly sever memory from the faculty of reason. Without doubt this bird, and the others I have mentioned, had infallible or at any rate excellent memories. It can hardly be argued that instinct takes my blackbird morning after morning to the same wall to see if its rival is ready for another trial of strength. Instinct, as we understand it, is originated or evolved through some advantage directly gained by either the species or the individual; there can surely be no gain to the individual in a series of fruitless battles which invariably have the same termination.

Instinct and not memory undoubtedly regulates the habits of certain animals, though the lower we go in the scale the more difficult it becomes to separate instinct from purely mechanical, haphazard actions. The mechanical movements of some of the lower vertebrates are more fallible than the growth of some climbing plants, whose tendrils reach out and feel for some object to grip with apparently intelligent precision. But with birds, though instinct pure and simple may lead the chick to peck for food on emerging from the egg, or cause it to crouch at the shadow of the approaching hawk, memory undoubtedly plays a most important part in its after life.

Memory, if we conclude as we safely may that this is the same bird that fought so persistently last year, has

been revived after a lapse of about ten months, indeed has survived that period when nuptial activities were latent. Memory and not instinct may explain why a bird returns year after year to an old nesting site, and why, if it departs slightly from the normal, it builds a similar nest each season, although heredity (or instinct if we like) will explain why it first selected a particular environment and constructed its nest on the general lines employed by its species.

Granting that our bird has an excellent memory, which urges it to come daily to the wall, and suggested the presence at this spot of its old enemy on February 12th, when apparently the bird was first influenced by sexual excitement, we are still face to face with the fact that its mental powers have strange limitations. It fails to profit by experience. To its limited reason, if it has any at all, the blow received from the unyielding glass is a hard knock given by its foe. Over and over again it receives this blow at exactly the same spot, yet its mental capacity is so limited that it fails to realise that there is something unreal in this repeated culmination of its encounters. Does it never wonder why it and its opponent always leave their respective walls at the same moment, always meet at the same half-way spot, and always with the same unpleasant bump? Had the bird never fought with a rival of flesh and blood we might have understood its difficulty, but over and over again it has "scrap" with cock blackbirds who venture near its sphere of influence. Surely with so good a memory it must recollect that the blows of beak, wing or foot differ from the everlasting bump against this shadowy rival; yet, apparently, it has no power to reason why!

We can hardly claim that the bird suffers from hallucinations, for it does not imagine a rival and fight

with nothing ; it strives with something visible, to it a rival of flesh and blood, another bird.

It is easy to say that this is a fool amongst blackbirds, but it is difficult to prove that any other blackbird is more reasonable. The irate master of this particular wall will not allow any other gay bachelor to approach. If we could be sure that another bird would perch upon that wall and either ignore the reflection or attack it and speedily find out his error, we could argue that our bird was mentally deficient, below the standard of his kind ; we might even believe that reasoning power was being slowly evolved in the species. As it is we can get no further than the fact that we have a bird with an excellent memory but with inability to use its brain power beyond a certain point. If after each series of assaults it learns that something is wrong, then its memory is indeed a strange one, for it speedily forgets these glimmerings of reason but remembers the spot and the rival who is always there. Probably it desists after each bout when it imagines either that it has punished the intruder sufficiently or when it has had sufficient punishment itself, for surely its poor head must ache after half-a-dozen bangs against that hard glass.

The persistence of the attacks of both Mr. Moffat's and my birds, lasting all through the period of excitement, suggests an instinctive stimulus to aggression but no stimulus to mental progress ; the bird is obsessed with its idea so long as its reproductive organs are active. There is no evidence that when its mate is ceasing to care about the welfare of the young she so carefully and even self-sacrificingly cherished, the male bird argues that there is no further need to drive away this ever returning rival. He simply tires of sexual warfare just as she tires of domestic cares—the sexual stimulus has worn itself out.

Unfortunately we cannot tell if the bird, during the months of inactivity in this particular direction, actually remembered the rival in the window ; probably it did not. Yet the return of sexual activity in the second week of February brings recollection of the fights of the previous spring, and though a year older it is no wiser than it was.

It is impossible to conceive that any other faculty than memory brings this bird daily to the wall, but it is possible that we sometimes draw false deductions because an animal has a good memory. Young birds, it is frequently stated, learn by experience and memory aids them to the wise future path or prevents them from repeating errors. It is stated that young birds have no intuitive dread of brightly coloured unwholesome or poisonous berries or understand nauseous food until they have experimented, but that once they have tasted and suffered they remember what to avoid in future. It is even said that the great infant mortality to be seen in birds is due to this method of experimental feeding. The reflection-fighting blackbird seems unable to learn by experience ; is it then wise to credit the immature bird with more reasonable or reasoning powers ?

The really poisonous fruits, and the lethally-armed and warningly-coloured insects and snakes, if trifled with by the young bird, leave little impression on its memory, and can, through heredity, have even less effect on future generations. Unless the bird escapes unharmed, and consequently has no evil effects to remember, it does not survive. Memory, then, is unavailing.

Take another instance, in an animal which undoubtedly possesses an excellent memory—the dog. In these days of numerous rapidly-moving motor vehicles, proportionately fewer dogs are run over than was the case when motors were the exception and not the rule. The

average dog, though there still are some fools, wisely retires to the side-walk when it hears an approaching motor. How did dogs as a whole learn to be careful? Not by bitter experience, or heredity working from this bitter experience; the dog which gets under a motor seldom has another chance or leaves progeny. We can only guess that the dog has realised, just as we have, that as vehicles move more quickly than they did it is wise to be careful. Though the dog remembers that a motor moves fast that memory was not cultivated by experience, at any rate in the majority of cases. Adolescent puppies are wiser to-day than those of twenty years ago.

In birds memory is wonderfully effective in leading them again to spots where they have found food plentiful. Here, undoubtedly, memory is of the greatest importance to both individual and species; but I fail to comprehend what benefit this blackbird with a memory receives from its repeated battles, unless it is that hardening process which makes it a more formidable warrior in other more genuine battlefields.

VIII. Studies in the Morphology of *Isoëtes*. II. The Analysis of the Stele of the Shoot of *Isoëtes lacustris* in the light of Mature Structure and Apical Development.

By WILLIAM H. LANG, M.B., D.Sc., F.R.S.,

Barker Professor of Cryptogamic Botany in the University of Manchester.

(Read January 12th, 1915. Received for publication January 19th, 1915.)

In the first of these studies the general construction of the stock of *Isoëtes* was considered and the distinction drawn between the shoot and a lower root-bearing region or rhizophore. A corresponding distinction into two regions was seen in the central vascular system of the plant. In this paper some features of the shoot will be considered in detail. The structure of the short stem bearing the crowded leaves is complicated by the slight longitudinal growth and the continued expansion of the cortex. This cortical expansion will not be dealt with at present, so that the chief questions to be considered are the method of apical growth, the differentiation of the stele from the procambium, the primary structure of the stele including the relation to it of the leaf-traces, and the anomalous secondary growth. The analysis of the stelar structure of *Isoëtes* in the light of its apical development may, it is hoped, contribute to stelar morphology and also afford a better basis for comparison with the stele of the *Lepidodendrea*. These general questions will, however, only be touched on in this paper, which will be limited to the description and analysis of the stele of well grown plants of *Isoëtes lacustris*. The description

May 31st, 1915.

may be regarded as applying to the genus since the essential features have been found to correspond in *I. lacustris*, *I. saccharata*, *I. foveolata*, *I. setacea* and *I. hystrix*.

The structure of the stem of *Isoetes* and of its stele has been more or less accurately described and figured by a number of investigators. Most of the facts stated below are indicated in one or other of the previous descriptions, but divergence of opinion exists with regard to many of them and it cannot be said that the usual descriptions of the anatomy of this plant are either clear or adequate. An independent re-examination of the question was therefore necessary.

As is well known, the stele of the stem of *Isoetes* has no pith, but has a central column of xylem composed of short tracheides mixed with parenchyma. The leaf traces radiate from the periphery of the stele. Around the stele a zone of secondary tissue, which may be referred to by the non-committal name of "prismatic zone," is developed centripetally from a meristematic layer. This rather ill-defined secondary meristem is usually regarded as contributing on its outer side to the cortical growth. The general features just mentioned are those shown in the usual figures of the stele of *Isoetes* and referred to in the text-books. The oft-reproduced figure by Potonie¹ may be quoted in illustration.

While the xylem of the leaf-trace is clearly continuous with that of the stele there is difference of opinion as to whether the phloem of the leaf-trace is continuous with stelar phloem or indeed whether there is any primary phloem in the stem stele. There is further wide difference of opinion as to the nature of the secondary tissue

¹ "Aus der Anatomie lebender Pteridophyten." *Abh. z. geol. Spez. v. Preussen. a. d. Thuring. Staat.*, VII., 1887.

referred to above as the prismatic zone. A further consideration of the literature will serve to make these differences of opinion clearer.

The secondary zone surrounding the primary stele of *Isoëtes* was at first regarded as corresponding to ordinary secondary wood although only a few of its elements might become lignified.² This view has recently been defended in detail by Miss Stokey.³ This investigator does not recognise any phloem in the stem, though she admits its existence in the leaf-traces and root-bundles. She regards the prismatic zone as secondary xylem composed of lignified tracheides, immature tracheides and parenchyma cells. Since all the secondary tissue produced internally to a meristem arising just outside the primary wood is regarded as xylem there is on this view nothing anomalous about the secondary thickening of *Isoëtes*. The secondary xylem formed would be strictly comparable in position to the corresponding tissue of the *Lepidodendreae* or of a *Gymnosperm*. It will be shown later how completely this interpretation is at variance with the anatomical facts.

The view of Russow⁴ on the other hand was that the secondary tissue produced to the inside of the meristem in *Isoëtes* was in part at least phloem, though he recognised that xylem might also be developed in the prismatic zone. The fact that a secondary tissue consisting of both xylem and phloem was produced to the inside of the meristem only, and not xylem to the inside and phloem to the outside, indicated that the secondary thickening in *Isoëtes* was anomalous. It has since been frequently compared with the secondary growth of arborescent *Liliaceae* rather than with normal secondary thickening.

² Hofmeister. "Higher Cryptogamia," p. 361 (1862).

³ *Botanical Gazette*, 47, pp. 311-335 (1909).

⁴ "Vergleichende Untersuchungen," 1874.

Russow, to whom the name "prismatic layer" is due, appears to regard it as for the most part of the nature of phloem. He regarded the innermost portion of this tissue as corresponding to primary phloem, and clearly states that the phloem of the leaf-trace is continuous with this, just as the xylem of the trace is continuous with that of the stele. This view is thus sharply opposed to that considered above; it regards the stele as having xylem and phloem with which the xylem and phloem of the leaf-traces are continuous, while the secondary prismatic zone is of the nature of phloem with xylem elements (or cauline bundles) developed in it and is derived from a cambium of anomalous position. This cambium would originate just outside the primary phloem, *i.e.*, in a position corresponding to the pericycle.

Without entering into the work of other investigators it will be sufficient to consider the description of the stele of *Isoëtes hystrix* by Scott and Hill,⁵ which is the most critical investigation of the stele of *Isoëtes* yet made. These investigators agree with Russow in regarding the secondary thickening which gives rise to the prismatic zone as anomalous, and the tissue produced centripetally from it is shown to consist histologically of parenchyma, phloem, and tracheides. The whole of the phloem in the stem is regarded as secondary. In another part of the paper, however, they point out clearly that the tissue immediately outside the stelar xylem is parenchyma, and that, in certain cases, the phloem immediately outside of this may be reasonably regarded as primary. In any case, however, they agree with Russow as to the continuity of the phloem of the leaf-trace with the innermost elements of the prismatic zone, which have the histological characters of phloem.

⁵ *Annals of Botany*, XIV. (1900), pp. 413-454.

Besides the usual, marked, anomalous secondary thickening, Scott and Hill call attention to other manifestations of secondary growth. In two cases a cambial layer was observed arising internal to the first, and presumably later than this, from the parenchymatous cells immediately outside the xylem; this cambium, like the usual anomalous one, produced all three tissues (phloem, wood and parenchyma) on its inner face. Still more interesting, however, is the reference to indications of secondary growth in a normal position, the cambium lying between the primary xylem and the phloem and adding a few elements of secondary xylem in immediate contact with the primary wood. The distinction between the activity of this normal cambium and the anomalous cambium is not, however, quite clearly made. Attention has been drawn to these particular points in Scott and Hill's description, because they will be seen to be in agreement with some distinctions that will be made below in the stelar structure of *Isoetes lacustris*.

Previous work and opinion on two intimately related questions, the apical growth and the cauline or common nature of the stele, must also be briefly referred to. Hofmeister⁶ referred the apical growth of the stem to a single initial cell. Later investigators (Bruchmann,⁷ Hegelmaier,⁸ Farmer,⁹ Wilson-Smith¹⁰) have regarded it as due to an apical group of cells. Scott and Hill,¹¹ on the whole, agree with this latter view, while pointing out that the appearances in some cases suggest the presence of a single apical cell. The decision of this question is of less

⁶ *loc. cit.*

⁷ *Jena. Zeitschrift* (1874).

⁸ *Bot. Zeitung* (1874).

⁹ *Annals of Botany*, V. (1890).

¹⁰ *Botanical Gazette*, XXIX.

¹¹ *loc. cit.*

importance than the attainment of a clear conception of how the growth at the apex gives rise to the resulting mature structure. This is not made clear in the existing descriptions and from some of the growing points figured it is difficult to infer any way in which growth could take place. The figures of Bruchmann, however, appear to be wonderfully accurate, and though the apical region is sometimes flat, I have usually found it forming a small cone as he describes. His figures also show the arrangement of the cells immediately below the growing point, and allow of inferences being made as to the differentiation of the mature stele from the procambium.

Related to this question of the differentiation of tissues behind the apex, is the anatomical question as to whether there is a cauline portion of the stele upon which the leaf-traces are inserted or whether the stem-stele is to be regarded as wholly composed of united leaf-traces. The latter view was expressed by Hofmeister and has been held by a number of later investigators, while Hegelmaier, Bruchmann and Scott and Hill regard the stele as cauline. The important question is not merely which term should be applied but what is the actual relation borne by the leaf-traces to the stele.

With this introductory survey of previous investigation, which will serve to bring out the points still more or less in dispute, I may now describe the results of my re-examination of the apex and stele of *Isoëtes lacustris*.

The study of numerous plants of *Isoëtes lacustris* has shown that while the actual apex of the stem is sometimes flat it usually forms a slight conical projection. The appearance of this in longitudinal section is shown in *Photos* 1, 2, 3, 4 and 16. I do not propose to enter here into the actual construction of the apical region further than to say that while usually a small group of

initial cells appear to be present, the possibility of there being a single initial cell in some cases is not excluded. The initial cells of the apical group appear to cut off segments parallel to their bases and also to their free sides. Corresponding to this a distinction is evident immediately below the apex between a central column of the procambial tissue, and around this radiating rows of cells serving to carry the surface with the young leaf-rudiments further away from the apex. This construction can be seen clearly in *Photos* 3, 4. These radiating rows of cells have nothing to do with the secondary thickening, as has often been assumed, and are also present in shoots where no secondary meristem will be established (*cf. Photo* 16); the radial arrangement here expresses the cortical expansion, the special importance of which in the growth of the shoot of *Isoëtes* was referred to in the first of these studies. In the procambial region behind the apex no limit for the stele can at first be recognised, but on following back from the meristematic to the differentiated regions in *Photos* 3, 4 and 16 it will be evident that both the central group of procambium and the inner portions of the radiating rows are involved in the stele when delimited. The meristematic tissue formed behind the initial group of cells appears to give rise only to the central portion of the cylinder of xylem, while from the inner portion of the radiating rows of cells an outer zone of xylem, a parenchymatous xylem sheath and the primary phloem are differentiated. In the absence of any distinct pericyclic or endodermal sheaths the phloem forms the outer limit of the stele. From what has been said and from a consideration of the photographs it will be evident that a more or less regular and continuous radial seriation may be traced through the outer zone of xylem, the phloem, and on into the cortex. The radial

arrangement of the outer tracheides of the xylem thus resulting is not to be taken as indicating their origin from a cambium; nor is a like inference to be drawn from the radial seriation of the cortical cells. That this has nothing to do with the activity of the meristem usually established just outside the stele is shown by the fact that the stele is fully differentiated at a level above which the anomalous secondary growth begins (*Photo 3*), and still more strikingly by the fact that the stelar differentiation and cortical growth described above take place in stems in which no anomalous secondary growth is present (*Photos 2, 16*). When this secondary growth takes place it adds a thicker or thinner zone of secondary prismatic tissue immediately outside the primary phloem (*Photo 1*). It has further to be added to this account of the structure as seen in longitudinal sections that the leaf traces are differentiated along the lines of the radiating zone around the central procambial region. They thus extend inwards through the cortex and into the outer zone of the primary stele (*cf. especially Photo 16*). It will be shown later that all the tissues of the trace (xylem, parenchyma and phloem) are continuous with corresponding tissues of the stele.

The various regions distinguished above and their general relations to the apical meristem are expressed diagrammatically in *Text-fig. 7, A*, on p. 44, which will also serve as a key to the interpretation of the photographs of such sections. The lettering of the figure will be explained in relation to the corresponding diagram of a transverse section.

Having thus obtained a general idea of the method of apical growth and of the relation to this of the regions of the stele and cortex as seen in longitudinal section, a more accurate study of the construction of the stele may

be made from transverse sections selected from complete series. Thus *Photos* 5-8 are from a plant which had well-marked secondary growth, while *Photos* 9-13 are from another plant in which the primary stele was larger, but had little, if any, secondary growth.

Photos 5-8 are from the series of transverse sections already illustrated in outline in *Text-fig. 2* of the preceding paper. *Photo* 5 shows an older region of the stele where the secondary prismatic zone is fully developed. It shows the innermost portion of the cortical tissue, the cells of which are arranged in radial rows. The ill-marked secondary meristem lies at the inner limit of this, just outside the clear looking zone of prismatic tissue. The latter is almost entirely composed of cells with small nuclei (secondary sieve-tubes) arranged in radial rows continuous across the cambium from the cortex. Embedded in the secondary tissue is the primary stele from which the bases of old leaf-traces diverge. The entering leaf-traces consist of phloem and xylem separated by conjunctive parenchyma. The phloem of the trace as will be shown more clearly below, was continuous with the innermost layer of phloem of the stele; this primary phloem was differentiated before any secondary meristem was established. The conjunctive parenchyma of the trace was continuous with the parenchymatous xylem-sheath of the stele. The xylem of the leaf-trace can be traced some depth into the xylem of the stele, coming into contact with the central region of this. The outer xylem, only slightly developed in this plant, fills up the intervals between the entering traces and renders the outline of the xylem in cross section almost circular instead of stellate.

The structure of the stele of this plant is better shown in *Photo* 6, taken at a level where the primary tissues are

complete and secondary growth is just commencing. In this figure, and still more clearly in *Photo 7*, where the primary structure is almost complete while there is no trace of a secondary meristem, the primary phloem forms the outer limit of the stele and is succeeded by the cortex. The sieve-tubes of the primary phloem are characterised by their small dense-looking nuclei, and can be traced continuously from the stem to the leaf-traces. Within the phloem of both stem and leaf-trace come parenchymatous cells with large and normal-looking nuclei belonging to the xylem-sheath. The xylem of the entering traces can be traced into relation to the central region which here forms the main bulk of the primary xylem of the stem stele, but comparison of *Photos 6* and *7* will show that other tracheides have been developed at the periphery of the xylem in the intervals between the inner ends of the leaf-trace xylem-strands. These form the outer primary xylem, and although this is not strongly developed in this plant it will be evident as it bulges out the outline of the stele between the leaf-traces in *Photo 6*. In *Photo 7* its differentiation is just commencing, and at places the radial seriation of cells from the region of outer xylem, through the xylem sheath, phloem and into the cortex can be made out.

In *Photo 8* a section of the stele at a still higher level is shown. The phloem is just beginning to be differentiated and serves to define the outline of the stele from the cortex. The tissue of the stele is not yet differentiated from the procambial condition. The only lignified elements are the first formed tracheides of the base of one leaf-trace (*px*), which serve to show the depth to which the leaf-traces extend. Within this is the central region of the procambium, exhibiting no regular direction of cell division. Around this central region, and including the

bases of the leaf-traces, is a zone in which the radial arrangement of the cells can be traced out to and beyond the phloem. This is the zone destined to give rise to the outer xylem and the parenchymatous xylem-sheath.

If these sections are followed in the reverse order, from *Photo 8* to *Photo 5*, they will be seen to agree with the information supplied by the longitudinal sections as to the regions of the procambium and their behaviour in the differentiation of the stele. Though the outer zone of xylem is not specially prominent, this specimen would, by itself, justify the distinction of regions in the stele already suggested. These regions are, however, still more clearly shown in *Photos 9-13*, in which the differentiation of a larger stele from another plant is followed from the procambial region downwards. After the description of the preceding plant attention need only be briefly called to the features exhibited by this series of photographs. The differentiation may here be traced from above downwards. The plane of section in this series was slightly oblique, sloping downwards from right to left as the photographs are placed on the plate.

The section in *Photo 9* is just below the level of the apex and above any definitely limited stele. It shows the central group of cells of the procambium (α), and around this the radiating arrangement of the rows of cells (β), which carry out the young leaves and will give rise to the cortex and the outer regions of the stele. In *Photo 10* there is still no lignification of the stele. The outer limit of the stele is, however, clearly marked on the left side of the photograph by the differentiation of the phloem which is seen to be continuous with that of the leaf-traces, as they enter the stele. The phloem is rendered conspicuous in this section by the deep staining of its walls with hæmatoxylin. Within the phloem comes

a fairly broad zone of procambium with radially-arranged cells, and this zone surrounds the central region where the cells exhibit no such regular arrangement. No lignification has yet taken place, but the leaf-traces can be seen to enter and form part of the outer procambial zone but not to penetrate the central column of tissue. This relation is more clearly seen in the slightly lower section (*Photo 11*), where the first tracheides of the entering leaf-traces (*px.*) are lignified. The differentiation has not yet affected the procambial tissue, whether outer or inner, though the two regions can be distinguished, as in the preceding photograph. The first tracheides of the base of the leaf-trace xylem to be lignified are the most central ones, and these are the only elements in the stele that may reasonably be identified as protoxylem (*px.* in *Photos 8, 11, 12*).

In *Photo 12*, lignification of the tracheides has commenced both in the inner and outer regions of the procambium. The slight obliquity of the section leads to this being evident only on the left-hand side, where the plane is lower. It will be clear that no direction of lignification is to be recognised, that tracheides are differentiated both in the inner and outer xylem, and that it is the arrangement and shape of the outer procambial cells that determine the different appearance of the elements of the outer xylem. At least one layer of parenchymatous cells is left between the outermost tracheides and the phloem; this constitutes the xylem-sheath.

The developmental stages followed in successively lower sections in the preceding photographs explain the resulting mature structure of the stele shown in *Photo 13*. In this the inner xylem (*a*), into contact with which the tracheides of the leaf-traces (*b*¹) can be followed, can be

distinguished from the outer xylem (b^2) between the entering poles of the leaf-traces and continuous with the metaxylem of the leaf-traces. Outside the xylem comes the parenchymatous xylem sheath (c), and outside that again the phloem (d). A point of interest is the appearance of the outermost tracheides of the outer xylem, suggesting that they are the most recent addition to the lignified elements of the stele. They suggest a secondary addition from divisions taking place in the region of the xylem sheath, and evidently correspond to the secondary tracheides in a normal position mentioned and figured in *I. hystrix* by Scott and Hill.

In *Photo 14*, a complete section of the stele of this plant at a lower level is shown, and at the same lower magnification as the stele of the other plant in *Pl. 2, Photo 5*. The difference in size of the primary stele of the two plants is evident on comparing the photographs, and also the difference in development of an anomalous secondary zone. This is well marked in *Photo 5*, while in *Photo 14* the anomalous secondary growth is barely indicated. The slight obliquity of the section is an advantage, for the plane of the section on the right of *Photo 14* nearly follows that of an entering leaf-trace; the extent to which the xylem of the latter enters the stelar xylem is thus well seen. On the left-hand side the continuity between the phloem of the leaf-traces and the primary phloem of the stem-stele is brought out by the development of callus in the sieve-tubes. Internal to the phloem the continuity of the parenchyma from the leaf-trace to the xylem-sheath of the stele can also be followed.

These two points, the continuity of the phloem and the deep attachment of the leaf-trace xylem, are of such importance in the interpretation of the stele that it is advisable to demonstrate them in longitudinal section also.

The continuity of the phloem between leaf-trace and stele, and the existence of primary phloem in the latter, is most unequivocally shown in those shoots in which no anomalous secondary growth takes place and only the primary components of the stele are present. The phloem of stele and leaf-traces can be recognised even in the low power photograph of such a specimen in *Photo 2*, the continuity of the phloem from leaf-trace to stele is more clearly shown for the older leaf-trace, in which the callus formation makes the sieve-tubes prominent, in *Photo 15*. It is shown for the upper functional leaf-trace in *Photo 16*, which also gives a more detailed view of the apical region of this stock, the transition to the differentiated region of the stele and the absence of any anomalous secondary growth.

In *Photo 16* also the xylem of the leaf-trace can be followed for some depth into the outer zone of xylem of the stele. The radial seriation of the cells which will give rise to the outer xylem can also be seen between the functional leaf-trace and the meristematic one above it. The relations between the entering leaf-traces and the outer xylem is still better seen in *Photo 17*, where the attachment of three leaf-traces to another stele is represented. Above the uppermost leaf-trace the corresponding regions can be traced in procambial tissue. In this stem secondary growth is about to follow directly on the establishment of the primary structure. Lastly, in *Photo 18*, where the plane of section passes tangentially through the outer xylem of another stele, the groups of tracheides forming the xylem of the entering leaf-traces (b^1) are embedded among the tracheides of the outer xylem (b^2).

Confusion between the primary phloem of the stem stele and the secondary prismatic tissue is possible, where, as is usual, the anomalous meristem proceeds to form

secondary sieve-tubes similar to those of the primary phloem. When, however, the first anomalous secondary tissue to be laid down develops as xylem, there is no possibility of confusing it with normal secondary xylem, for it lies outside the primary phloem, which is continuous into the leaf traces. Indeed, the primary phloem is brought out more clearly in such specimens. An example is shown from a transverse section of the stele of *Isoetes setacea* in *Photo 19*, and its inclusion with the illustrations of the structure of *I. lacustris* will serve not only to show this type of secondary development but the similarity in construction of the steles of these two species. This essential agreement, as stated in the beginning of the paper, holds for all the species compared.

If we now sum up the result of the analysis of the stele and surrounding tissues of *Isoetes* in the light of the apical development, we find that the following regions can be distinguished from within outwards:—

- a. Central column of primary xylem ; this is a strictly cauline region of the stele.
- b. Peripheral zone of xylem.
 - b¹. Bases of xylem of leaf-traces, joining on to the central column of xylem (a).
 - b². Radially seriated xylem between the entering leaf traces.
- c. Parenchymatous xylem sheath, continuous with similar region in the leaf-trace.
- d. Primary phloem, continuous with phloem of leaf-trace.
- e. Secondary prismatic tissue (tracheides, sieve-tubes or parenchyma).
- f. Meristem of secondary prismatic tissue, originally established just outside the primary phloem.
- g. Cortical tissue.

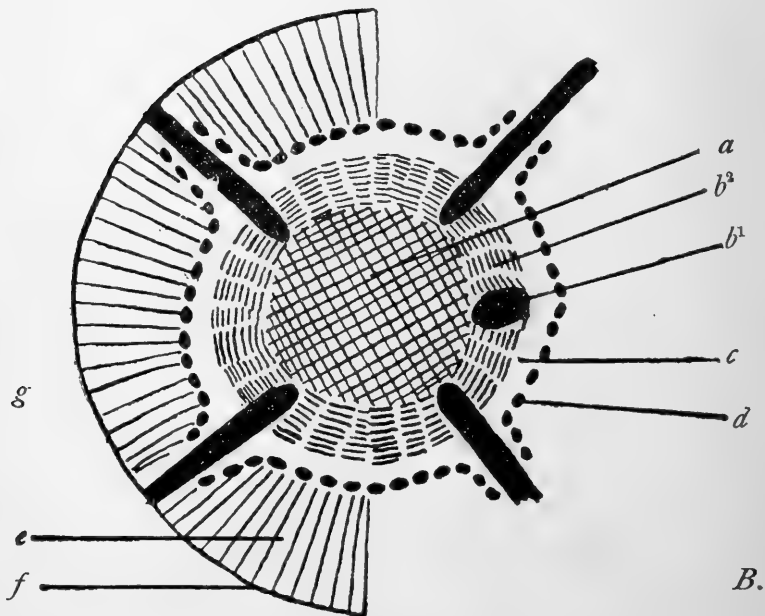
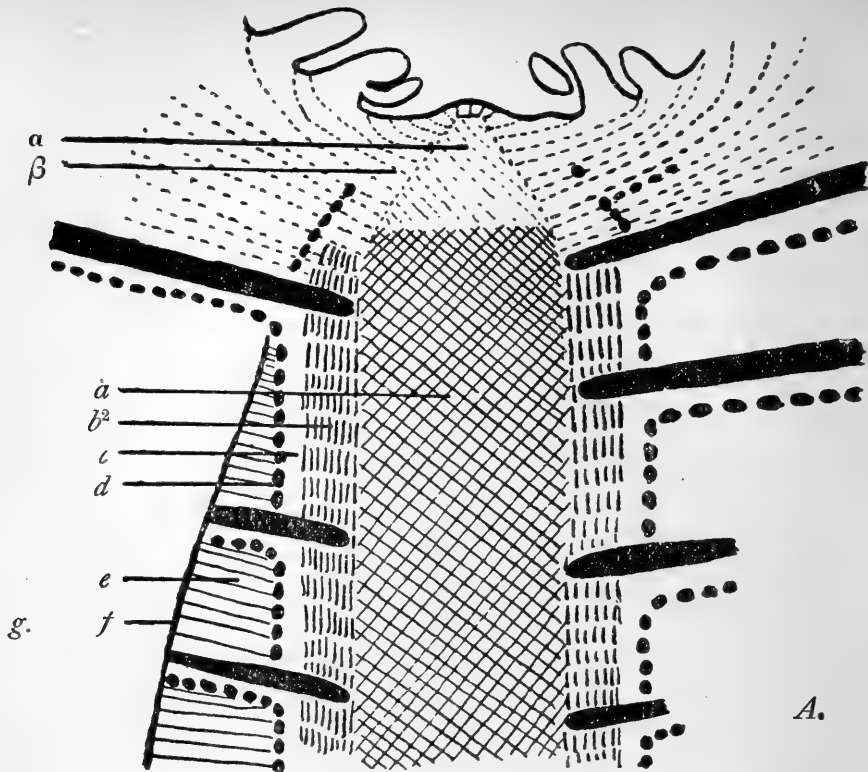

Text-figure 7.

Diagrams of the relative positions of the tissues of the stele of *Isoetes* as seen in longitudinal (*A*) and transverse (*B*) section.

On the left-hand side the anomalous meristem and secondary zone are represented, while only the primary components of the stele are shown on the right-hand side.

a, central region of procambium; *β*, radiating rows of meristem around central region. *a*, central column of primary xylem; *b*¹, base of xylem of leaf-trace; *b*², outer xylem; *c*, xylem sheath; *d*, primary phloem; *e*, secondary prismatic tissue; *f*, meristem *g*, cortical tissue.

The procambial tissue formed immediately behind the growing point (α) gives rise to the central column of primary xylem (α) only. The other primary tissues of the stele are differentiated in the inner portion of the radiating rows of meristematic cells (β) surrounding the central column at the apex; the cortex is derived from the outer portion of this radiating tissue. There is thus a radial seriation of the elements from the cortex to the outer xylem quite independent of any secondary growth. A zone of prismatic tissue may or may not be intercalated as an anomalous secondary growth produced on the inner side of a meristem arising just outside the primary phloem.

This analysis of the stele of *Isoetes* is in no way theoretical, but is based on the facts of development and structure recorded in the photographic illustrations to this paper. It can be recognised in every well grown plant, though the various regions may be more or less fully represented. It will perhaps be of assistance to the reader in the study of the photographs to represent the facts diagrammatically for a transverse and a longitudinal section of the stele. In the accompanying figures (*Text-fig. 7, A B*) the various tissues are denoted by the letters used in the table above, and the corresponding letters are used in the plates.

The description here given of the structure of the stem of *Isoetes* is consistent with the facts recorded by other investigators, especially by Russow, Hegelmaier, Bruchmann and Scott and Hill, though it gives greater precision to the distinction of the various regions. All these investigators recognised the anomalous position as well as nature of the prismatic secondary zone. On the other hand, the interpretation of the stele, with its secondary tissue given by Miss Stokey, is directly contradicted by the results of the present investigation, for

she regards the whole prismatic tissue as imperfectly developed xylem, and does not appear to regard its position or that of its meristem as other than ordinary. Indeed, on the view this investigator takes of the nature of the prismatic tissue (and bearing in mind that she does not recognise any primary phloem in the stem continuous with that of the leaf-trace), the secondary tissue of *Isoëtes* would correspond in position to the ordinary secondary wood of a Gymnosperm or one of the Lepidodendreae. The facts, when fully examined, seem, however, quite inconsistent with such an interpretation. A similar misconception vitiates the description of the stele of *Isoëtes* by C. E. Bertrand, Cornaille and Hovelacque,¹² a description that is of special interest since it was expressly made for comparison with the Lepidodendreae.

I do not propose to enter at present into the comparative bearings of this somewhat detailed consideration of the stelar structure of *Isoëtes*. The fact that the differentiation of the stele proceeds with practically no longitudinal extension is an advantage in relating the mature structure to the procambial stage and to the stem apex. The result of the analysis of the stele of *Isoëtes* is to facilitate its comparison with other plants. Two aspects of this may be merely indicated in conclusion.

It would appear that the correlative of the centripetal primary xylem of the Lepidodendreae in the stele of *Isoëtes* is not the whole xylem, but the central column on which the bases of the leaf-traces abut. This central xylem is centripetal in that the only elements to which the name protoxylem can be applied are the central elements of the mesarch leaf-traces where these form part of the stele. The outer xylem of *Isoëtes*, between the poles of the entering leaf-traces may in a sense correspond

¹² Assoc. Franc. pour l'avancement des Sciences. St. Etienne, 1897, p. 483.

to the normal secondary xylem of the *Lepidodendrea*. It certainly corresponds in position to this, although almost entirely laid down in the procambial region. On this view the stele of *Isoetes* would contain the tissues corresponding to the centripetal primary xylem, the normal secondary xylem and also to the anomalous secondary tissues (found in some species) of *Lepidodendrea*. The comparison cannot be followed further at present, since it would involve entering into details regarding disputed questions with regard to the extinct plants.

Another interesting aspect of the stele of *Isoetes* may lastly be touched upon as bearing on general stelar morphology. The other existing Lycopodiales (*Selaginella* and *Lycopodium*) contrast with the Filicales in having a central column of centripetal xylem on to which the small leaf-traces join without affecting the periphery of the stelar xylem. In *Lycopodium*, however, Sinnott¹³ has shown that the stele is just mesarch when a leaf-trace has joined it. In the stele of some of the Filicales I have been led to attach importance to the distinction of *inner xylem* (corresponding to the centripetal xylem of *Lycopodium*) and *outer xylem*; ¹⁴ the latter, together with the bases of the leaf-traces forms a peripheral zone of xylem. *Isoetes* alone, among existing Lycopodiales, exhibits a corresponding state of affairs, and this may perhaps be associated with the fact that it is a relatively large-leaved form. At any rate, the outer xylem of *Isoetes* corresponds on the one hand with the outer primary xylem of the Filicales, and on the other hand has been seen to correspond in morphological position to the secondary xylem of the *Lepidodendrea*. The Ophioglossaceæ show, however, that a sharp line cannot be drawn between outer

¹³ *Bot. Gazette*, 48, p. 138.

¹⁴ *Ann. Bot.*, XXIX., p. 37.

primary xylem and secondary xylem,¹⁵ so that this double comparison is not unjustified.

The leaf-traces, as they join the central column of the stele, seem to have a determining influence, not only on the development of the outer xylem, but on the differentiation of the surrounding soft tissues. The xylem-sheath and phlœm are both continuous from the leaf-traces to the periphery of the stele. We seem here to be dealing with fundamental facts of stelar construction, since parallels can be drawn, not only with the more primitive steles of the sporophyte, but with the stele-like central strand of the Polytrichaceæ.

It is impossible to discuss here the general considerations thus raised, but it will be evident that a more accurate analysis of the stele of *Isoëtes* not only affords points for comparison with the Lepidodendreaë, but promises to be of interest from the standpoint of general stelar morphology.

¹⁵ Lang. *Ann. Bot.*, XXVIII., p. 239.



EXPLANATION OF PLATE I.

All the figures are from untouched photographs and, with the exception of *Photo 19*, are of *Isoetes lacustris*. α , central region of procambium; β , radiating rows of meristem around central region; a , central primary xylem; b^1 , base of xylem of leaf-trace; b^2 , outer xylem; px , protoxylem; c , xylem sheath; d , primary phloem; e , secondary prismatic tissue; f , meristem; g , cortical tissue.

Photo 1. Median longitudinal section of the stem of a well-grown stock, in which the primary stele is surrounded by a zone of anomalous secondary thickening. ($\times 67$.)

Photo 2. Median longitudinal section of the stem of an equally large plant, in which, however, no anomalous secondary thickening has taken place. The continuity of the phloem, conjunctive parenchyma and xylem of the leaf-trace with the corresponding tissues of the stele can be followed, and this specimen demonstrates the existence of primary phloem in the stele of *Isoetes*. ($\times 67$.)

Photo 3. Median longitudinal section of the apical region of another stem, to show the general relation of the differentiation behind the apex to the mature structure. ($\times 130$.)

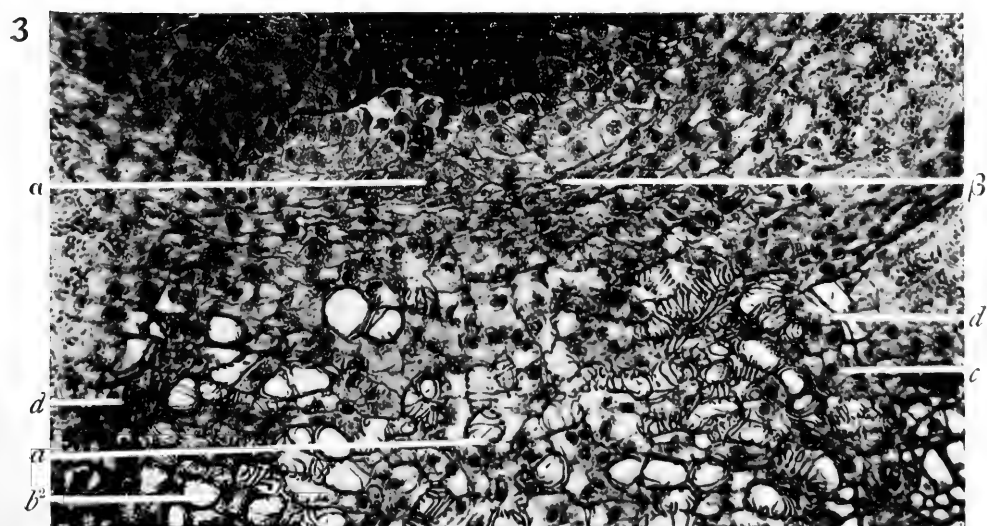
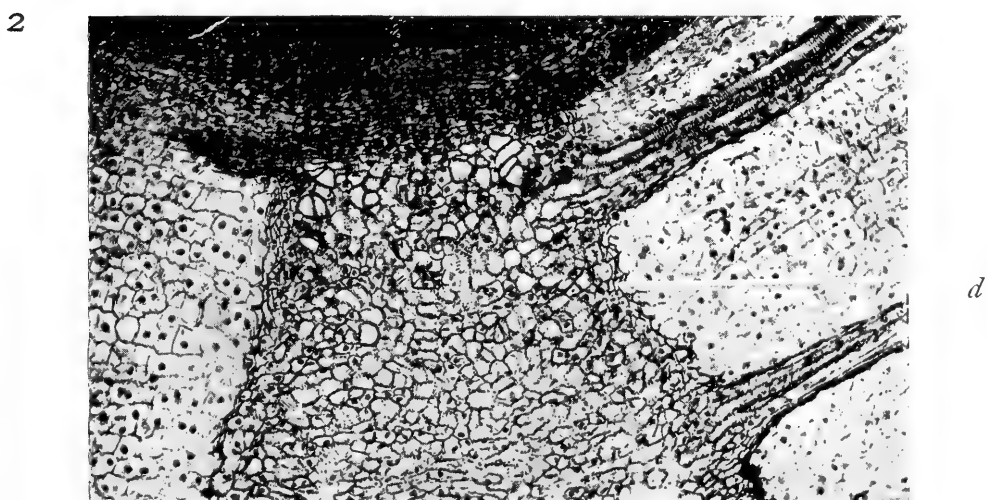
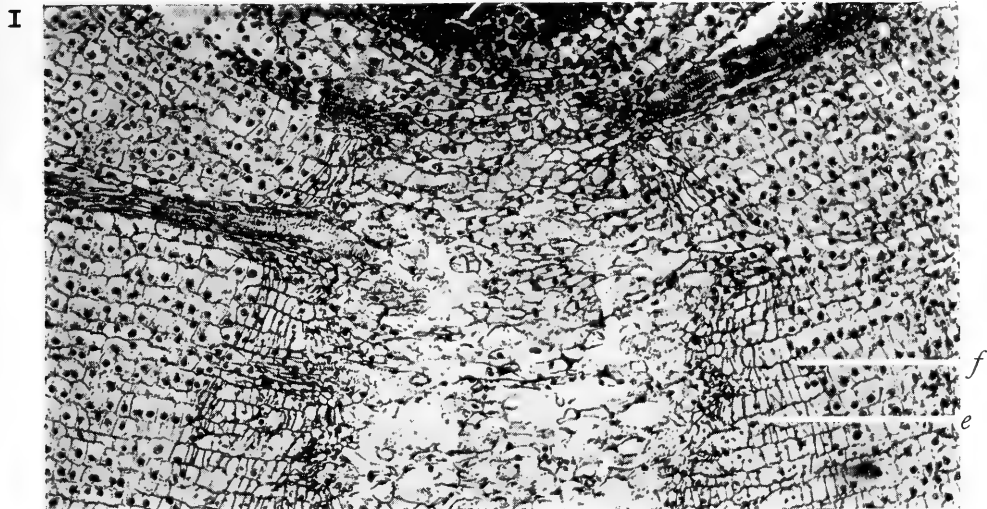

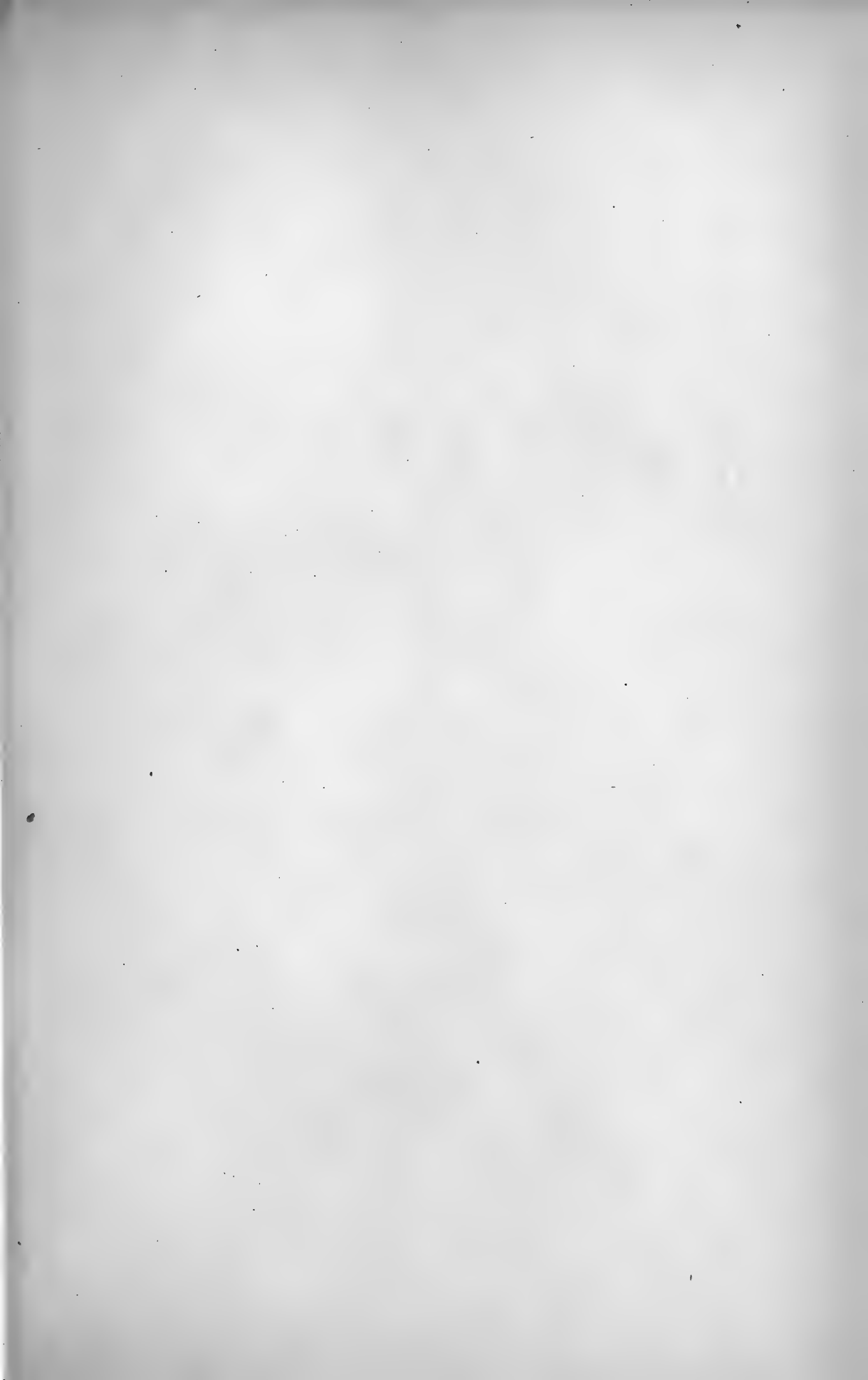

PLATE II.

- Photo 4.* Longitudinal section through the apical region of another plant, showing the relation between the procambial regions and the differentiated stele. ($\times 130$.)
- Photo 5.* Transverse section through the stele of a plant with a well-marked secondary zone. ($\times 67$.)
- Photo 6.* Transverse section of the stele of the same plant showing the primary differentiation complete, but no secondary growth. ($\times 130$.)
- Photo 7.* Transverse section from the same plant showing the differentiation of the stele almost complete. ($\times 130$.)
- Photo 8.* Transverse section from the same plant still nearer to the apex, showing the stele just delimited but still undifferentiated. A central and a peripheral region can be distinguished in the still meristematic tissue. The only lignified elements are the protoxylem of a leaf-trace (*lx*) in the peripheral region. ($\times 130$.)

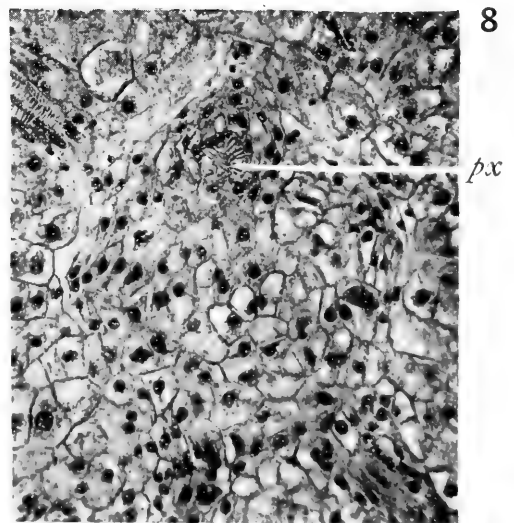
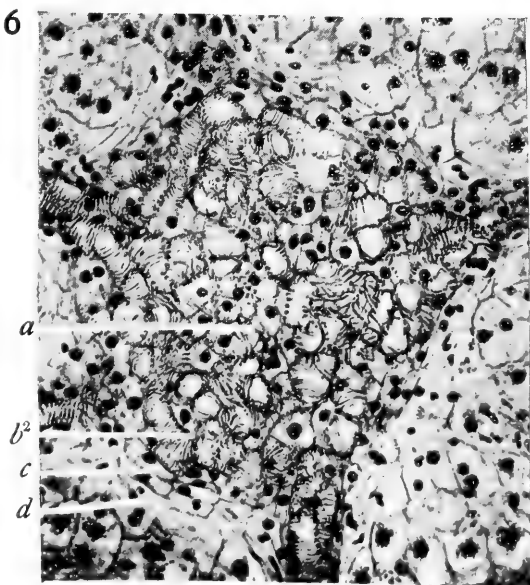
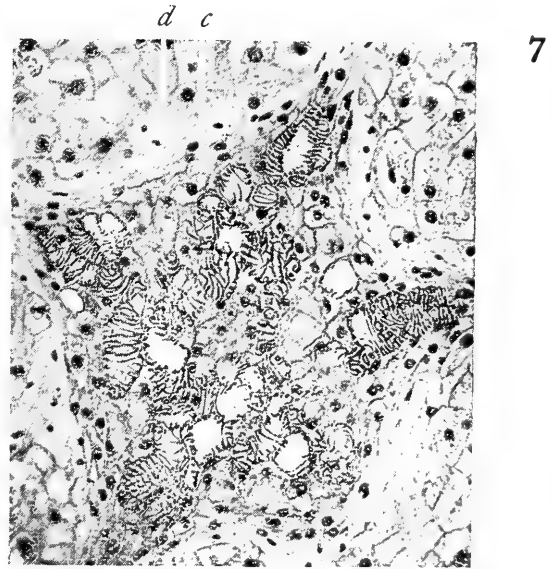
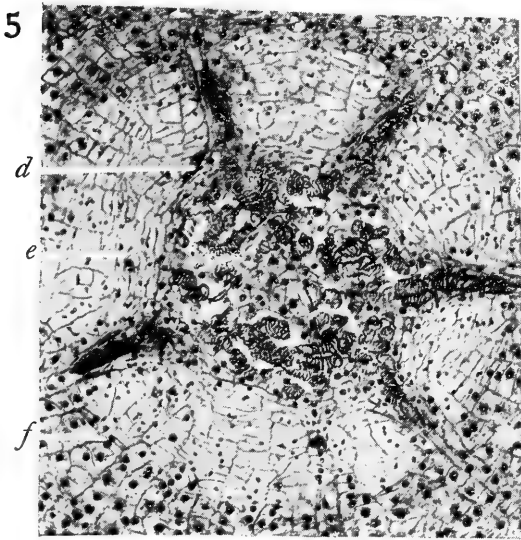
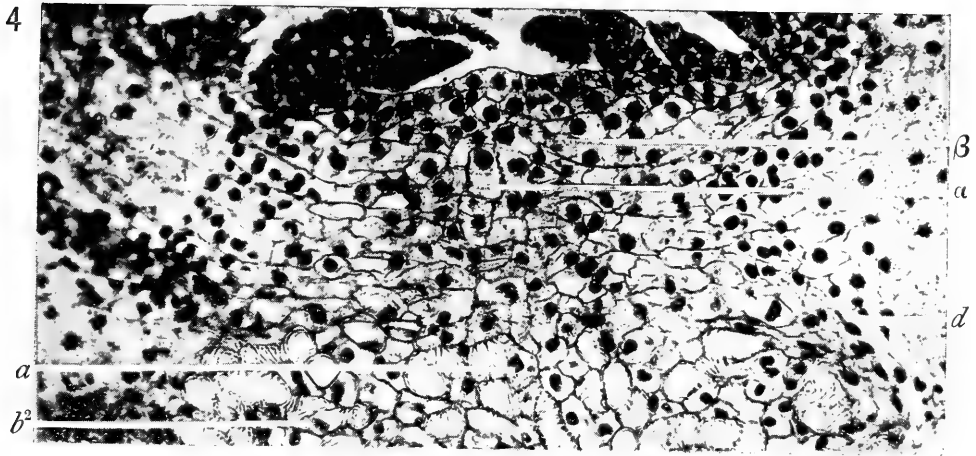
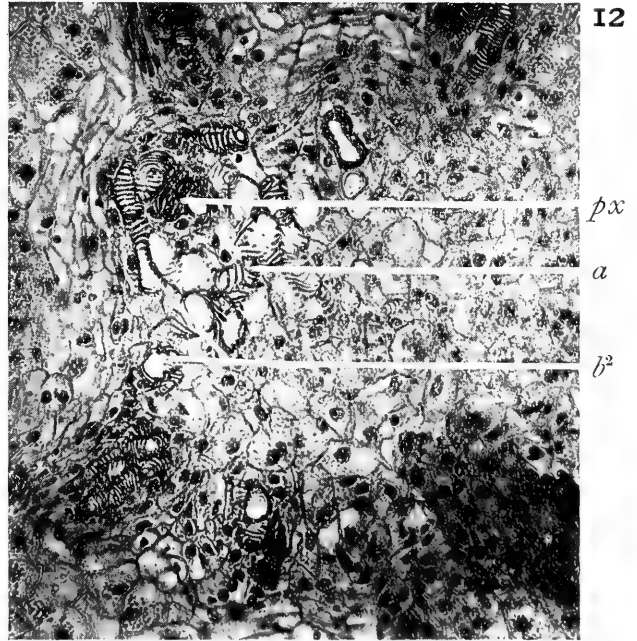
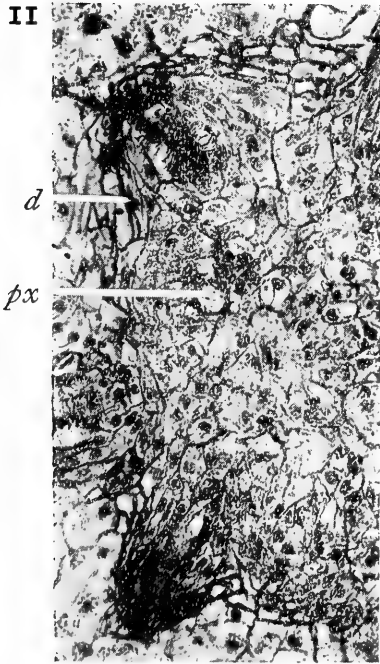
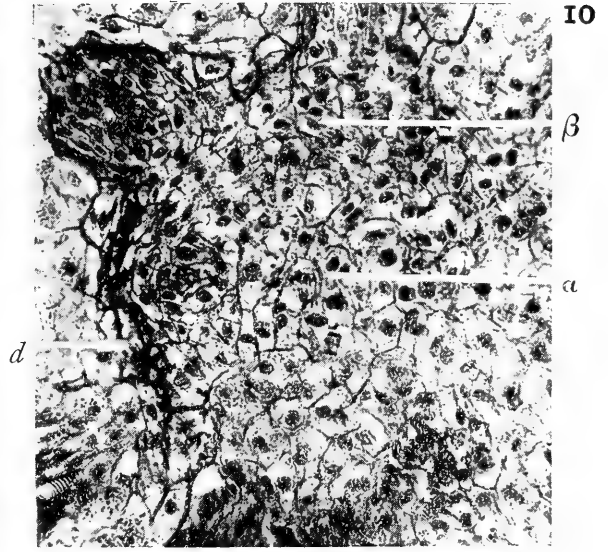
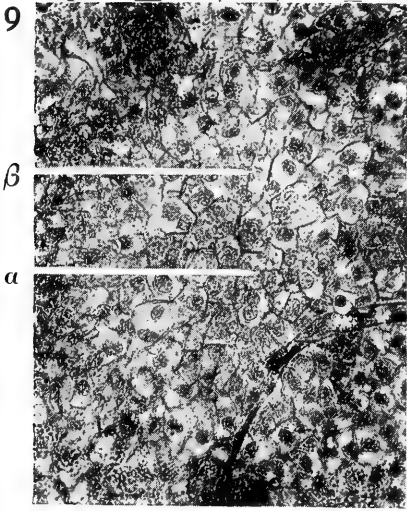





PLATE III.

- Photo 9.* Transverse section just below the apex of another plant, showing the central and outer regions of the meristematic tissue. ($\times 130$.)
- Photo 10.* Somewhat lower section of the same plant. The stele is delimited by the differentiation of the phloem on the left-hand side. The xylem is still unlignified but the outer and inner procambial regions are distinguishable. ($\times 130$.)
- Photo 11.* Slightly lower section of the same plant, showing that the first apparent lignified elements belong to the bases of leaf-traces in the outer zone of xylem. ($\times 130$.)
- Photo 12.* Still lower section of same plant, showing the progress of differentiation in both the central and outer regions of the procambium. ($\times 130$.)
- Photo 13.* Fully differentiated stele of same plant, showing all the primary tissues. ($\times 130$.)



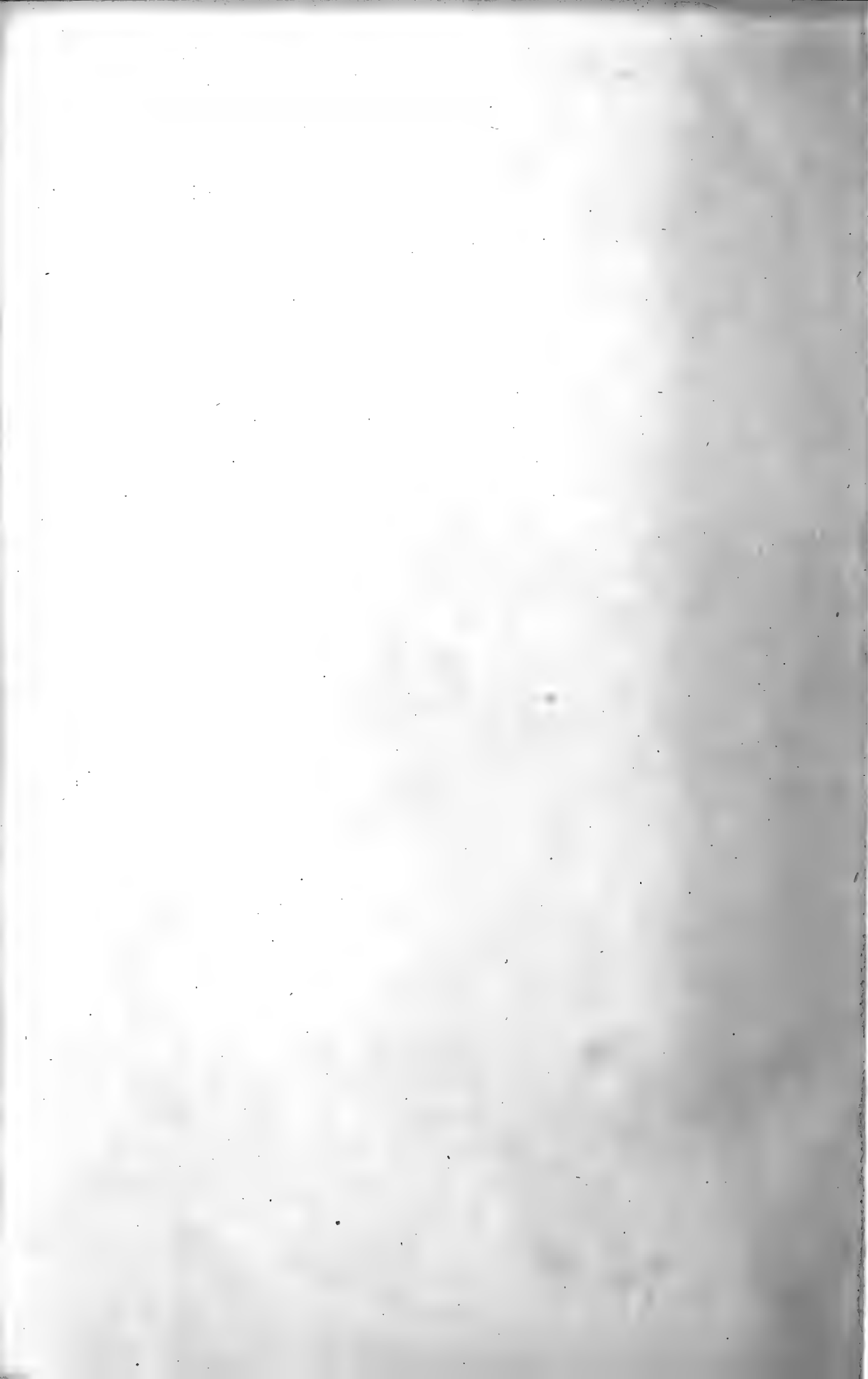
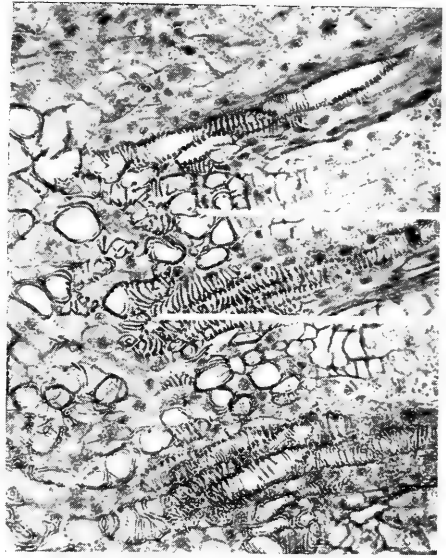
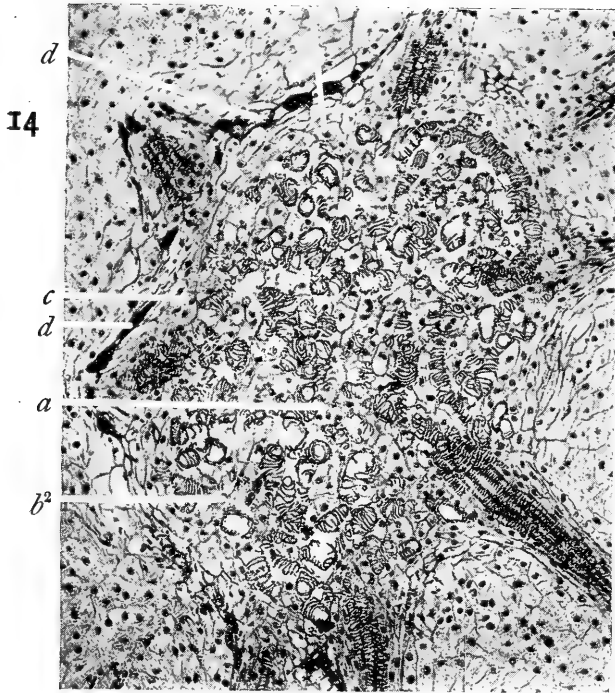



PLATE IV.

- Photo 14.* Slightly oblique transverse section of a stele without evident secondary thickening, showing the general structure, the continuity of primary phloem from leaf-trace to stem and the deep insertion of the leaf-trace xylem into the xylem of the stele. From the same plant as the Photos in *Plate III.* ($\times 67.$)
- Photo 15.* Continuity of primary phloem followed from stem to leaf-trace in a stem without any secondary growth. The sieve tubes are filled with callus. *Cf. Photo 2.* ($\times 130.$)
- Photo 16.* Similar continuity of phloem shown in a functional leaf-trace of the plant also shown in *Photo 2.* This more highly magnified section shows the absence of any secondary meristem and also the differentiation of the stele in relation to the apical meristem. ($\times 130.$)
- Photo 17.* Part of a longitudinal section of another plant showing the deep insertion of the xylem of three leaf-traces and the development of radially seriated outer xylem between them. ($\times 130.$)
- Photo 18.* Tangential section of the outer xylem showing the entering leaf-traces and the intervening tracheides. ($\times 130.$)
- Photo 19.* Portion of a transverse section of the stele of a plant of *I. setacea*, where the first secondary tissues to be developed are tracheides. The primary phloem is seen internal to this anomalous secondary xylem which is marked by the line from *e.* ($\times 130.$)

c



18

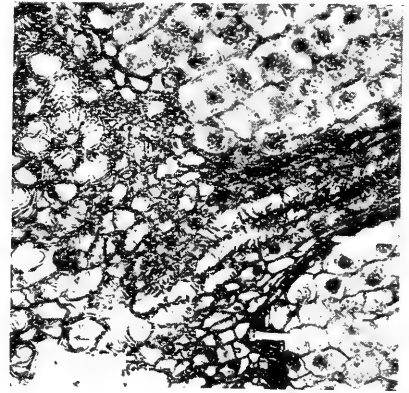
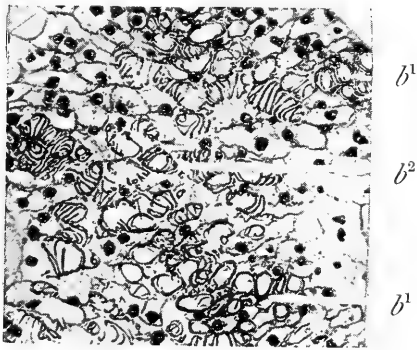

19

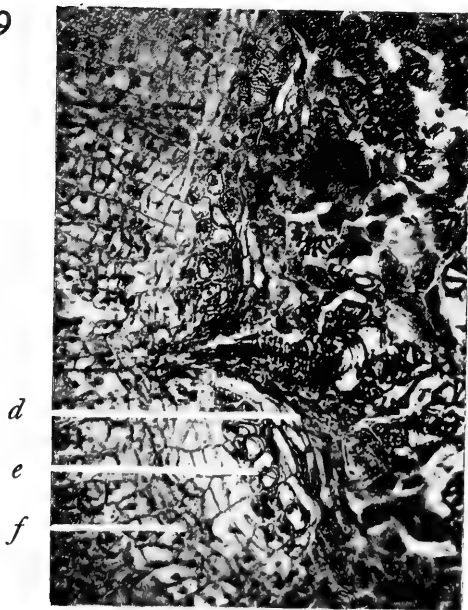

16

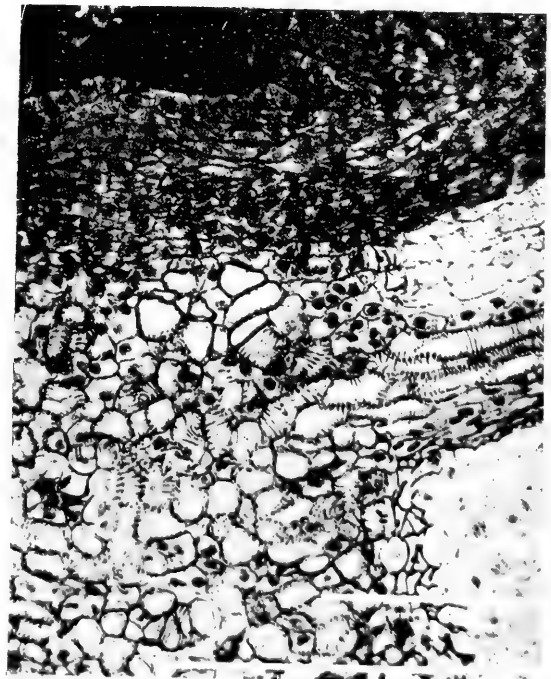

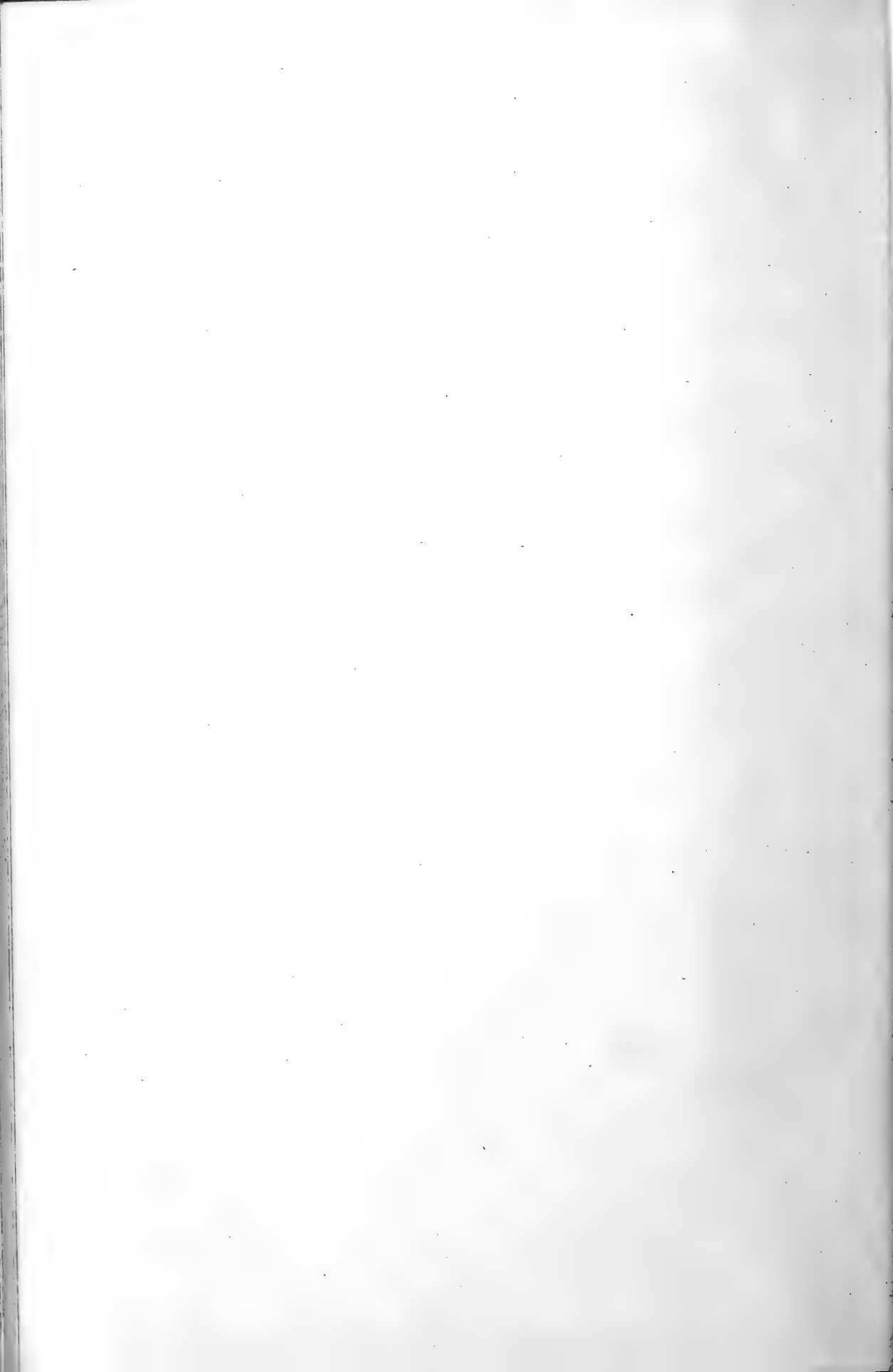

IX. On two cases of Parallelism in the Aphidæ.

By A. W. RYMER ROBERTS, M.A.

(Received and read March 23rd, 1915.)

The existence of parallel races of insects, having a common ancestry, but differing in their habits, and sometimes also in their external morphology, was brought into prominence by Blochmann, Dreyfus and Cholodkovsky (1) in the course of their early researches into the biology of the *Chermesinæ*, especially *Chermes abietis* and *Ch. strobilobius*. Since that time—the closing years of the last century—a doubt has arisen as to whether the races of *Chermes* which were then considered as forming the most prominent examples of the phenomenon, the monœcious and diœcious forms, ought properly to be regarded as parallel races, rather than as biological species which have evolved and are maintaining a different life-history. Cholodkovsky (2) has more recently given different specific names to the monœcious and diœcious forms, maintaining that they are distinct biological species, though corresponding stages are morphologically almost indistinguishable. But he has been obliged to admit, in conformity with the researches of Börner (3), that although in the forests of Russia the monœcious forms constitute different biological species, yet in Switzerland, where he has also made experiments, both monœcious and diœcious forms may arise from the same stem-mother. This he interprets as the primitive condition, while the separation of the two forms in Russia, he regards as the initial stages in the further evolutionary development of separate species. As

June 7th, 1915.

to what may be the true interpretation in these cases of monœcious races, I am not at present prepared to express an opinion; though one cannot but be impressed by analogous cases such as *Pineus (Chermes) pini*, which appears to be capable of continuing to exist for an indefinite time on trees of the genus *Pinus*, without any sexual reproduction, while the race which Cholodkovsky has named *Chermes orientalis* has a biennial life cycle migrating from the *Pinus* to *Picea orientalis*, a spruce of Caucasian origin, as its primary host and there reproducing sexually.

Before leaving the *Chermesinæ*, I may mention certain other cases of parallelism to which Professor Paul Marchal (4), of Paris, has drawn attention. These are taken from the progeny of what he calls the "hiemosistens," the wintering form in *Cnaphalodes* and *Dreyfusia* (two of the genera into which Börner has divided the old genus *Chermes*). The wintering forms live on the secondary host, a larch or silver fir (*Abies*), as the case may be.

The hiemosistens develops in the spring and lays eggs which may produce no less than four different forms, three of them at least morphologically distinct: (i.) the sistens, which may not develop before the spring following; (ii.) the progrediens, another apterous form, which speedily reproduces parthenogenetically; (iii.) the exsul alata, a winged form, which remains upon the secondary host and there lays eggs, and (iv.) the sexupara, the winged form, which flies back to the primary host and there lays eggs, which hatch into the only sexual generation of the life cycle. Marchal states definitely that the germ plasm of the progrediens and the exsul alata are different from that of the sistens.

It will be apparent that this phenomenon may be of considerable interest from the evolutionary standpoint,

and it is of hardly less interest from the economic. We know, for instance, in a well-studied case such as *Aphis avenæ*, one of the common apple aphids, that, once the winged forms have left our apple trees in the spring, we shall not be further troubled with this species until its return from the graminaceous secondary host in the late summer or autumn. No parallel race appears to remain on the apple. But in cases such as *Macrosiphum rosæ* on roses, and *Aphis rumicis* on beans and many other garden plants, we must expect that though winged forms are developed, which carry over the infection to fresh plants, unless some unexpected tragedy overwhelms them, there will remain a sufficiency of apterous individuals to maintain the strain on the plants under observation.

In the two cases to which I wish to draw the attention of the Society to-night, the production of parallel lines has been made known before in each instance, but I venture to think that the confirmatory evidence, which I have been able to obtain, may be of some interest to an English society, especially so since one of the species, *Hamamelistes tullgreni*, has not previously (so far as I know) been known to occur in this country.

Both species belong to the sub-family *Pemphiginae*, Mordw.

(i.) *Thecabius affinis*, Kalt.

The migration of this species from poplar to *Ranunculus* was made known by Mordwilko, who thus established the identity of what had previously been known as *Pemphigus affinis*, Kalt., with *Pemphigus ranunculi*, Kalt. The stem-mother hatches from an ovum laid on poplar and produces a "gall" at the edge of a leaf. Within this gall the second generation are produced and in due time develop wings. These are the *migrantes* which fly from

the poplar to *Ranunculus* at Midsummer. On *Ranunculus* two generations are produced, the second of which, as I understand Tullgren's description (5) to mean, are the sexuparæ. These migrate back to the poplar and there produce the sexuales (♂, ♀), from which the fertilised ova, producing the stem-mothers of the next year, are derived.

But Mordwilko has observed (and his observation is confirmed by Tullgren) that when the sexuparæ leave the *Ranunculus*, wingless individuals remain on that plant, and that the species is still to be found there during the winter. Tullgren's observation of this parallel race relates to the early part of June, a time when the stem-mother of the ordinary life-cycle is on the poplar. He then found wingless insects on *Ranunculus*, and by the end of the month these had flown away, though where they had flown to we do not know. Possibly it may have been to other *Ranunculus* plants, in which case they would correspond to the generation known as "exsules alatae" in certain species of *Chermes*.

My own observations fully confirm the main facts of the life cycle given by Tullgren, as the following epitome will show:—

Winged ♀ ♀ (migrants)—most had already flown—poplar. 25.vii.13.

Apterous ♀ ♀ and larvæ. *Ranunculus*. 15.vii.14.

Winged ♀ ♀ (sexuparæ) and larval sexuales—poplar. 6.ix.14—10.x.14.

Apterous ♀ ♀ and larvæ. *Ranunculus*. 9.x.14.

These last were sent to me by my friend, Mr. T. A. Coward, from Bowdon, and it will be seen that these wingless ♀ ♀ coincide in point of time with the winged sexuparæ, which migrated to the poplar. Doubtless the larvæ would have continued to live on the *Ranunculus*

during the winter¹ and they (or possibly their descendants) would have produced the generation found by Tullgren in June. The following scheme may make the life cycle of this species clearer:—

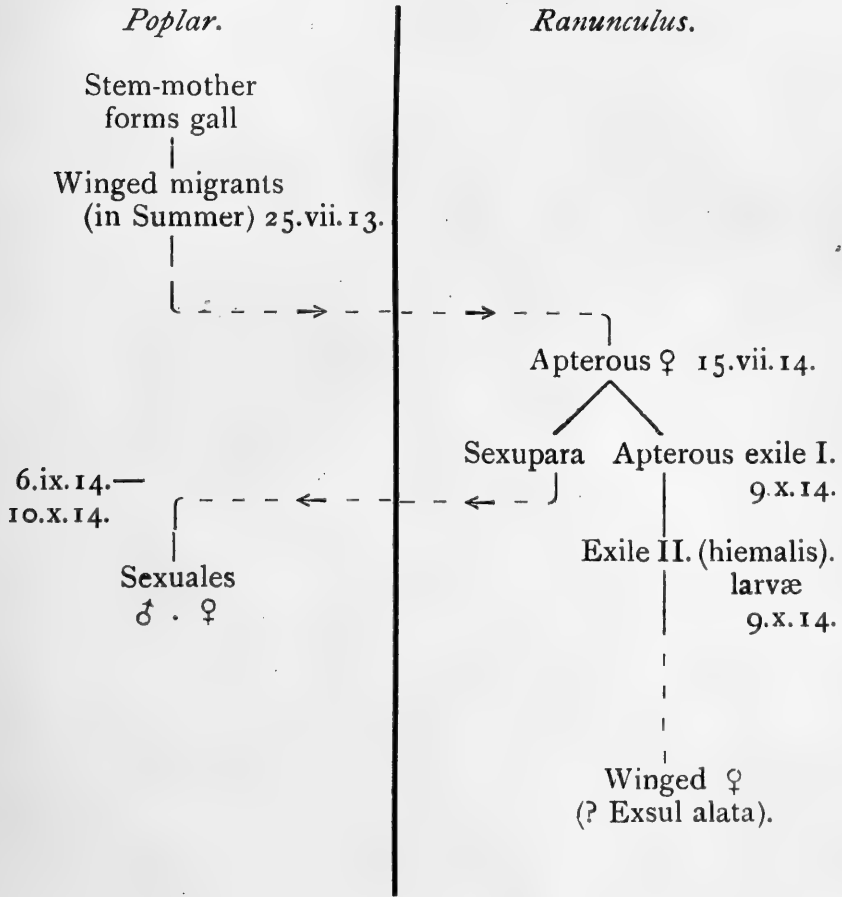

(ii.) *Hamamelistes tullgreni*, Meijere.

This species was described by Tullgren² as *H. betulæ*, Mordw., but it has been pointed out by Meijere (6) that there are certain points of difference between Tullgren's figures and description and those of Mordwilko (8). He

¹ Since the paper was read Mr. Coward has sent me adult specimens from *Ranunculus*. (26.iii.15.)

² See Reference (5), p. 51.

therefore has proposed the name of *tullgreni* for Tullgren's species. Mine seems to correspond closely with *tullgreni*; although there are certain small differences in the venation of the wings. As I find, however, that there is considerable variation in the venation of individuals of even the same colony, I think these discrepancies are slight enough to be disregarded.

The insect is of interest for several reasons, not least of which is the curious resemblance the wintering form

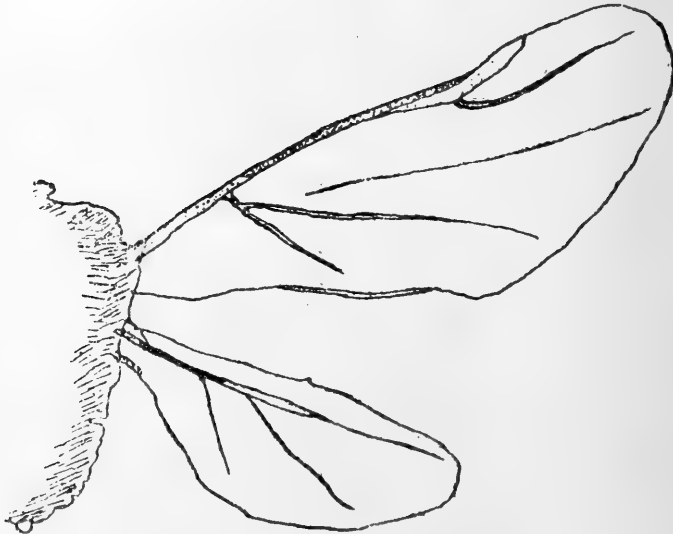

Text-fig. 1.—Hamamelistes tullgreni.
Sexupara.

bears to a coccid. Tullgren calls this the "aleurodifform" generation, and it is a very apt name. It has been found on birch (*Betula* spp.), but this appears to be the secondary host and the primary host at present remains to be discovered.

Early in May last I sent one or two twigs of birch with a certain species of aphid to Professor Theobald. In his reply he told me that on one of the birch twigs I had accidentally sent also a black scale-like aphid (evidently the mature winter-form of this species). I was, how-

ever, unable to find more specimens of it at the time, and it was not until 27th June that I again came across it. The forms then found were (i.) the alate ♀ sexupara, (ii.) the apterous ♀ of the summer generation, and (iii.) its larva. The insects are gregarious and as, I believe, is always the case, each colony was found on a single leaf of the birch, this being blistered in a characteristic manner by their sucking. A large amount of woolly secretion was deposited on the under side of the leaf about each of



Text-fig. 2.—Hamamelistes tullgreni, Meijere. Sexupara.
Abnormal venation of lower wing (right side).

the colonies. The sexuparæ of course flew away, and later in the year (29.vii.14, 20.viii.14) the numbers in the colonies were much reduced, but apterous ♀ ♀ continued to feed on the same leaves, which towards the end of August were considerably yellowed. On the 30th of that month I have a note of some small yellow objects in close proximity to the apterous ♀ ♀. These were probably the young larvæ of the winter generation, but unfortunately I did not certainly ascertain this at the

time. I believe the affected leaves fell off the tree shortly afterwards, and I have no further note of observation of the species until January 9th of the present year. On that date, after several fruitless searches, I succeeded in finding the winter form (*hiemalis*), most individuals of which were situated singly near the base of a leaf bud, though one or two were on other parts of the twig. They were of yellowish brown colour, with the legs and antennæ black, though these are not visible until the insect is



Text-fig. 3.—*Hamamelistes tullgreni*, Meijere.

Position of *hiemalis* at base of birch bud. 9/i./15. Length about 1·1 mm.

turned over, being enclosed by the expanded dorsal area. In length the *hiemalis* is about 1·1 mm. The dorsal surface is somewhat roughened by the waxy secretion given off and is considerably arched to the median line, where some traces of segmentation are visible.

Börner (7) gives a diagram illustrating the life cycle of *Hamamelistes betulinus*, Horv., in which the winged sexuparæ appear as the offspring of the first summer generation of apterous ♀♀ (*æstivales* I.) and makes his *æstivales* II. as a parallel generation to the sexuparæ.

I have not yet had an opportunity of investigating the spring generations of our species (*H. tullgreni*), and it may possibly have a slightly different life history to the closely allied one with which Börner deals. But unless there is a third summer generation, to correspond with the young larvæ found in June last and the mature females taken at the end of August, it appears to me that

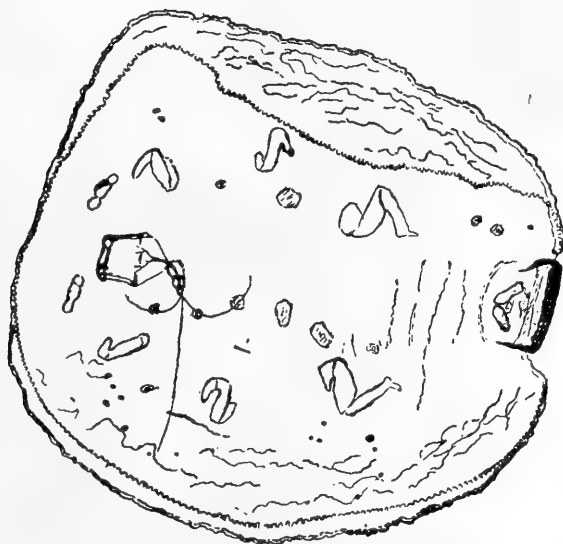

Text-fig. 4.—*Hamamelistes tullgreni*.

Hiemalis, $\times 48$.

With portion of margin further enlarged.

the *æstivales* I, and the *sexuparæ* must be the progeny of the *hiemalis* and therefore parallel races, as in analogous cases of *Chermes*. The larvæ and mature ♀ s found by me were certainly not parallel to the winged generation, as, according to Börner, they should have been in *H. betulinus*. I hope to be able to get further light on the subject of the spring and summer generations during the course of the year, as I have *hiemales* under observation.

REFERENCES.

- (1) N. CHOLODKOVSKY. *Horæ Soc. ent. Ross.*, XXIV. (1890), p. 386.
- (2) *Id.* Die Coniferen-Läuse Chermes. Friedlander, Berlin, 1907.
- (3) C. BÖRNER. Eine monographische Studie über die Chermiden. *Arb. aus der Kais. Biol. Anstalt*, VI., 2, 1908.
Id. Experimenteller Nachweis der Entstehung diöcischer aus monöcischen Cellaren. *Zool. Anz.*, XXXIII., p. 612, 1908.
- (4) P. MARCHAL. Contribution à l'étude de la Biologie de Chermes. *Ann. des Sci. Nat. (Zool.)*, XVIII., p. 158. *et seq.*
- (5) A. TULLGREN. Aphidologische Studien. *Arkiv för Zoologi*, V., No. 14.
- (6) MEIJERE. Zur Kenntnis von *H. betulæ*, Mordw. *Zeits. für Wiss. Insektenbiologie*, VIII. (1912), p. 90.
- (7) C. BÖRNER. Blattlausstudien. *Abhand. Naturwiss. Ver. Bremen*, XXIII., pt. 1, p. 164, 1914.
- (8) A. MORDWILKO. Beit. zur Biol. der Pflanzenläuse. *Biol. Centralbl.*, 1907, pp. 792-5.

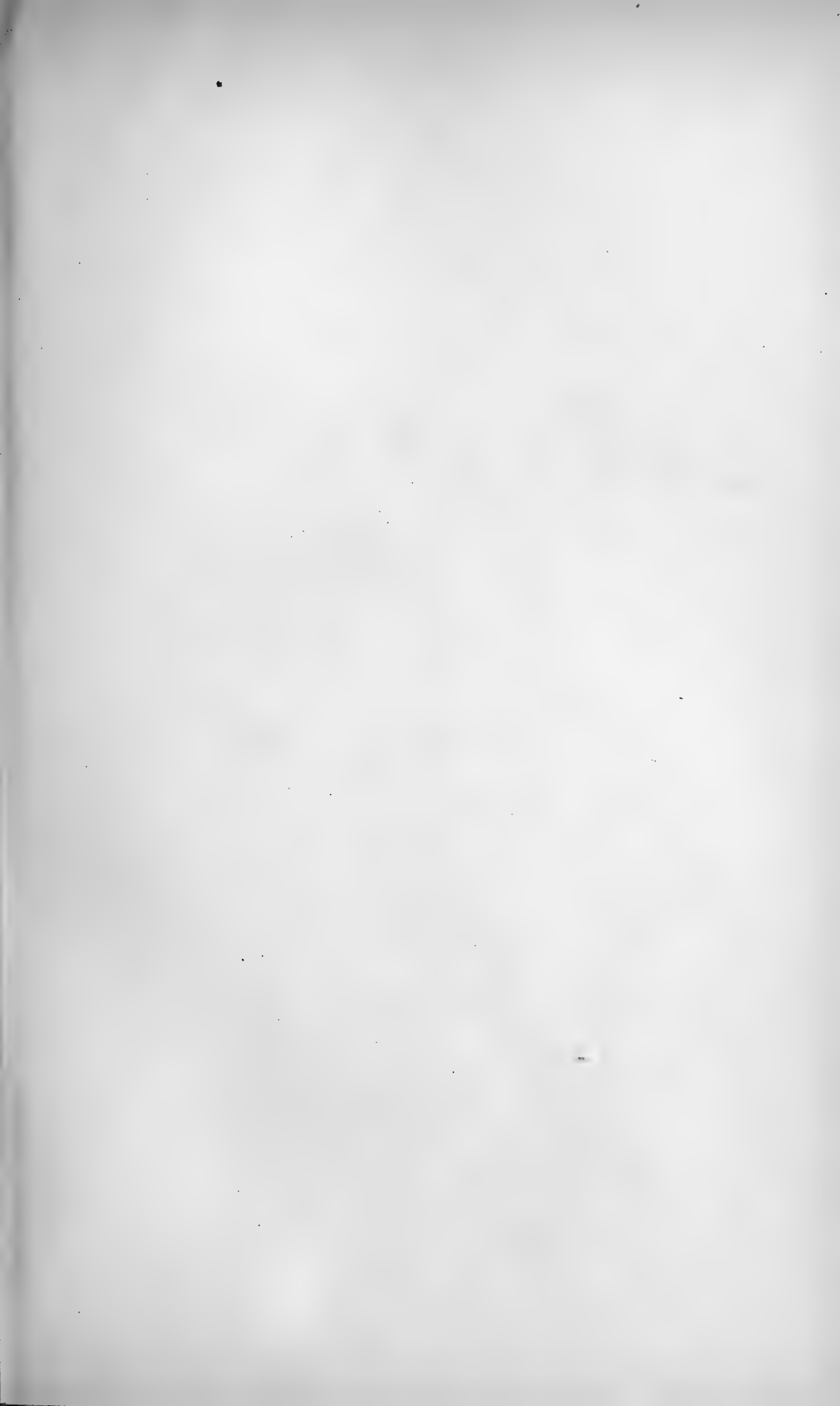

EXPLANATION OF PLATE.

Hamamelistes tullgreni, Meijere.

- (i.) Aestivalis II. Young larva, taken 27.vi.14. × 80.
- (ii.) Aestivalis II. Adult ♀, taken August, 1914. × 40.
- (iii.) Hiemalis. 9.i.15. × 40.

(Photos by Flatters and Garnett Ltd.)



Fig. 1.



Fig. 2.





X. On the Significance of the Geographical Distribution of the Practice of Mummification.—A Study of the Migrations of Peoples and the Spread of certain Customs and Beliefs.

By Professor G. ELLIOT SMITH, M.A., M.D., F.R.S.

(Read February 23rd, 1915. Received for publication April 6th, 1915.)

In entering upon the discussion of the geographical distribution of the practice of mummification I am concerned not so much with the origin and technical procedures of this remarkable custom. This aspect of the problem I have already considered in a series of memoirs (75 to 89¹). I have chosen mummification rather as the most peculiar, and therefore the most distinctive and obtrusive, element of a very intimately interwoven series of strange customs, which became fortuitously linked one with the other to form a definite culture-complex nearly thirty centuries ago, and spread along the coastlines of a great part of the world, stirring into new and distinctive activity the sluggish uncultured peoples which in turn were subjected to this exotic leaven.

If one looks into the journals of anthropology and ethnology, there will be found amongst the vast collections of information relating to man's activities a most suggestive series of facts concerning the migrations of past ages and the spread of peculiar customs and beliefs.

If a map of the world is taken and one plots out (*Map I.*) the geographical distribution of such remarkable

¹ These figures refer to the bibliography at the end.

July 7th, 1915.

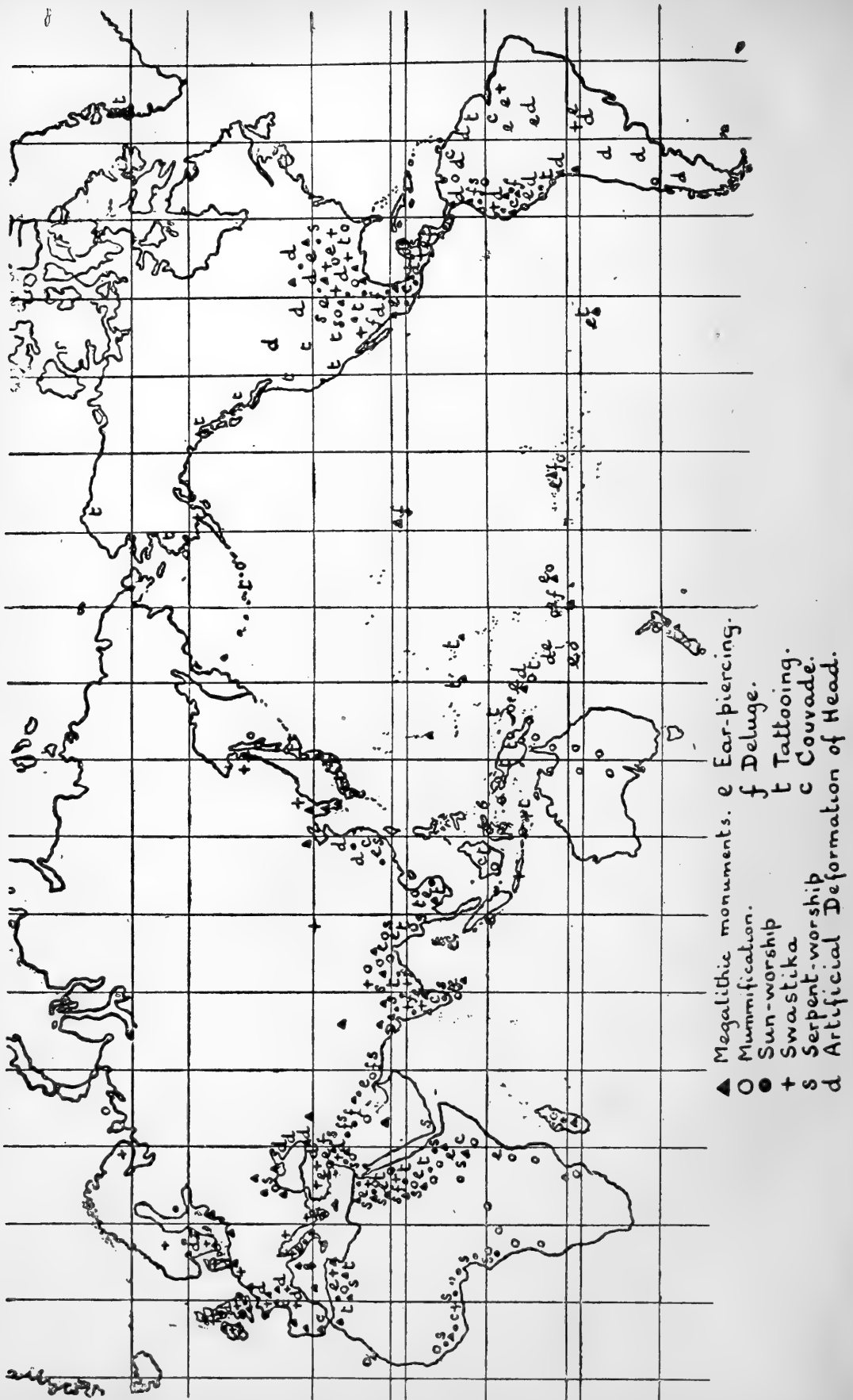

Map 1.—A rough chart of the geographical distribution of certain customs, practices and traditions. [None of these areas of distribution is complete. The map shows merely the data referred to in this memoir or in the literature quoted in it.]

customs as the building of megalithic monuments (see for example Lane Fox's [Pitt Rivers'] map, 20), the worship of the sun and the serpent (51 ; 103), the custom of piercing the ears (see Park Harrison, 29), tattooing (see Miss Buckland, 10), the practice of circumcision, the curious custom known as *couvade*, the practice of massage, the complex story of the creation, the deluge, the petrification of human beings, the divine origin of kings and a chosen people sprung from an incestuous union (W. J. Perry), the use of the swastika-symbol (see Wilson's map, 105), the practice of cranial deformation, to mention only a few of the many that might be enumerated, it will be found that in most respects the areas in which this extraordinary assortment of bizarre customs and beliefs is found coincide one with the other. In some of the series gaps occur, which probably are more often due to lack of information on our part than to real absence of the practice ; in other places one or other of the elements of this complex culture-mixture has overflowed the common channel and broken into new territory. But considered in conjunction these data enable us definitely and precisely to map out the route taken by this peculiarly distinctive group of eccentricities of the human mind. If each of them is considered alone there are many breaks in the chain and many uncertainties as to the precise course : but when taken together all of these gaps are bridged. Moreover, in most areas there are traditions of culture-heroes, who brought in some or all of these customs at one and the same time and also introduced a knowledge of agriculture and weaving.

So far as I am aware no one hitherto has called attention to the fact that the practice of mummification has a geographical distribution exactly corresponding to the area occupied by the curious assortment of other practices

just enumerated. Not only so, but in addition it is abundantly clear that the coincidence is not merely accidental. It is due to the fact that in most regions the people who introduced the habit of megalithic building and sun-worship (a combination for which it is convenient to use Professor Brockwell's distinctive term "heliolithic culture") also brought with them the practice of mummification at the same time.

The custom of embalming the dead is in fact an integral part of the "heliolithic culture," and perhaps, as I shall endeavour to demonstrate, its most important component. For this practice and the beliefs which grew up in association with it were responsible for the development of some of the chief elements of this culture-complex, and incidentally of the bond of union with other factors not so intimately connected, in the genetic sense, with it.

Before plunging into the discussion of the evidence provided by the practice of mummification, it will be useful to consider for a moment the geographical distribution of the other components of the "heliolithic culture." I need not say much about megalithic monuments, for I have already considered their significance elsewhere (90 to 96); but I should like once more specifically to call the attention of those who are obsessed by theories of the independent evolution of such monuments, and who scoff at Fergusson (17), to the memoirs of Lane Fox (20) and Meadows Taylor (100). The latter emphasises in a striking manner the remarkable identity of structure, not only as concerns the variety and the general conception of such monuments, but also as regards trivial and apparently unessential details. With reference to "the opinion of many," which has "been advanced as an hypothesis, that the common instincts of humanity have suggested

common methods of sepulture," he justly remarks, "I own this kind of vague generalisation does not satisfy me, in the face of such exact points of similitude . . . Such can hardly have been the result of accident, or any common human instinct" (p. 173).

But it is not merely the identity of structure and the geographical distribution (in most cases along continuous coast-lines or related islands) that proves the common origin of megalithic monuments. It is further strongly corroborated by a remarkable series of beliefs, traditions and practices, many of them quite meaningless and unintelligible to us, which are associated with such structures wherever they are found. Stories of dwarfs and giants (13), the belief in the indwelling of gods or great men in the stones, the use of these structures in a particular manner for certain special councils (20, pp. 64 and 65), and the curious, and, to us, meaningless, practice of hanging rags on trees in association with such monuments (20, pp. 63 and 64). In reference to the last of these associated practices, Lane Fox remarks, "it is impossible to believe that so singular a custom as this could have arisen independently in all these countries."

In an important article on "Facts suggestive of pre-historic intercourse between East and West" (*Journ. Anthr. Inst.*, Vol. 14, 1884, p. 227), Miss Buckland calls attention to a remarkable series of identities of customs and beliefs, and amongst them certain legends concerning the petrification of *dance maidens* associated with stone circles as far apart as Cornwall and Peru.

Taking all of these facts into consideration, it is to me altogether inconceivable how any serious enquirer who familiarises himself with the evidence can honestly refuse to admit that the case for the spread of the inspiration to erect megalithic monuments from one centre has

been proved by an overwhelming mass of precise and irrefutable data. But this evidence does not stand alone. It is linked with scores of other peculiar customs and beliefs, the testimony of each of which, however imperfect and unconvincing some scholars may consider it individually, strengthens the whole case by cumulation; and when due consideration is given to the enormous complexity and artificiality of the cultural structure compounded of such fantastic elements, these are bound to compel assent to their significance, as soon as the present generation of ethnologists can learn to forget the meaningless fetish to which at present it bends the knee.

But suppose, for the sake of argument, we shut our ears to the voice of common sense, and allow ourselves to be hypnotised into the belief that some complex and highly specialised instinct (*i.e.* precisely the type of instinct which real psychologists—not the ethnological variety—deny to mankind) impelled groups of men scattered as far apart as Ireland, India and Peru independently the one of the other to build mausolea of the same type, to acquire similar beliefs regarding the petrification of human beings, and many other extraordinary things connected with such monuments, how is this “psychological explanation” going to help us to explain why the wives of the builders of these monuments, whether in Africa, Asia or America, should have their chins pricked and rubbed with charcoal, or why they should circumcise their boys, or why they should have a tradition of the deluge? Does any theory of evolution help in explaining these associations? They are clearly fortuitous associations of customs and beliefs, which have no inherent relationship one to the other. They became connected purely by chance in one definite locality, and the fact that such incongruous customs reappear in asso-

ciation in distant parts of the globe is proof of the most positive kind that the wanderings of peoples must have brought this peculiar combination of freakish practices from the centre where chance linked them together.

Because it was the fashion among a particular group of megalith-builders to tattoo the chins of their women-kind, the wanderers who carried abroad the one custom also took the other: but there is no genetic or inherent connection between megalith-building and chin-tattooing.

Such evidence is infinitely stronger and more convincing than that afforded by one custom considered by itself, because in the former case we are dealing with an association which is definitely and obviously due to pure chance, such as the so-called psychological method, however casuistical, is impotent to explain.

But the study of such a custom as tattooing, even when considered alone, affords evidence that ought to convince most reasonable people of the impossibility of it having independently arisen in different, widely scattered, localities. The data have been carefully collected and discussed with clear insight and common sense by Miss Buckland (10) in an admirable memoir, which I should like to commend to all who still hold to the meaningless dogma "of the similarity of the working of the human mind" as an explanation of the identity of customs. Tattooing is practised throughout the great "heliolithic" track. [Striking as Miss Buckland's map of distribution is as a demonstration of this, if completed in the light of our present information, it would be even more convincing, for she has omitted Libya, which so far as we know at present may possibly have been the centre of origin of the curious practice.]

Tattooing of the chin in women is practised in localities as far apart as Egypt, India, Japan, New

Guinea, New Zealand, Easter Island and North and South America.

Miss Buckland rightly draws the conclusion that "the wide distribution of this peculiar custom is of considerable significance, especially as it follows so nearly in the line" which she had "indicated in two previous papers (8 and 9) as suggestive of a pre-historic intercourse between the two hemispheres. . . . When we find in India, Japan, Egypt, New Guinea, New Zealand, Alaska, Greenland and America, the custom of tattooing carried out in precisely the same manner and for the same ends, and when in addition to this we find a similarity in other ornaments, in weapons, in games, in modes of burial, and many other customs, we think it may fairly be assumed that they all derived these customs from a common source, or that at some unknown period, some intercourse existed" (p. 326).

In the first of her memoirs (8) Miss Buckland calls attention to "the curious connection between early worship of the serpent and a knowledge of metals," which is of peculiar interest in this discussion, because the Proto-Egyptians, who were serpent-worshippers (*see* Sethe, 74), had a knowledge of metals at a period when, so far as our present knowledge goes, no other people had yet acquired it. Referring to the ancient Indian Indra, the Chaldean Ea and the Mexican Quetzacoatl, among other gods, Miss Buckland remarks:—"The deities, kings and heroes who are symbolised by the serpent are commonly described as the pioneers of civilisation and the instructors of mankind in the arts of agriculture and mining."

Further, in an interesting article on "Stimulants in Use among Savages and among the Ancients" (9), she tells us that "among aboriginal races in a line across the Pacific, from Formosa on the West to Peru and Bolivia on the East, a peculiar, and what would appear to civilised

raises a disgusting mode of preparing fermented drinks, prevails, the women being in all cases the chief manufacturers; the material employed varying according to the state of agriculture in the different localities, but the mode of preparation remaining virtually the same" (9, p. 213).

If space permitted I should have liked to make extensive quotations from Park Harrison's most conclusive independent demonstration of the spread of culture along the same great route, at which he arrived from the study of the geographical distribution of the peculiar custom of artificially distending the lobe of the ear (29). This practice was not infrequent in Egypt (79) in the times of the new Empire, a fact which Harrison seems to have overlooked: but he records it amongst the Greeks, Hebrews, Etruscans, Persians, in Bœotia, Zanzibar, Natal, Southern India, Ceylon, Assam, Aracan, Burma, Laos, Nicobar Islands, Nias, Borneo, China, Solomon Islands, Admiralty Islands, New Hebrides, New Caledonia, Pelew Islands, Navigators Island, Fiji, Friendly Islands, Penrhyn, Society Islands, Easter Island, Peru, Palenque, Mexico, Brazil and Paraguay. This is an excellent and remarkably complete [if he had used the data now available it might have been made even more complete] mapping out of the great "heliolithic" track.

The identity of geographical distribution is no mere fortuitous coincidence.

It is of peculiar interest that Harrison is able to demonstrate a linked association between this custom and sun-worship in most of the localities enumerated. In the figures illustrating his memoir other obvious associations can be detected intimately binding it by manifold threads into the very texture of the "heliolithic culture." If to this we add the fact that in many localities the design

tattooed on the skin was the sun, we further strengthen the woof of the closely woven fabric that is gradually taking shape.

To these forty-year-old demonstrations let me add Wilson's interesting recent monograph on the swastika (105), which independently tells the same story and blazens the same great track around the world (see his map). He further calls attention to the close geographical association between the distribution of the swastika and the spindle-whorl. By attributing the introduction of weaving and the swastika into most localities where they occur by the same culture-heroes he thereby adds the swastika to the "heliolithic" outfit, for weaving already belongs to it.

To these practices one might add a large series of others of a character no less remarkable, such, for example, as circumcision, the practice of massage (57, 67 and 11), the curious custom known as *couvade*, all of which are distributed along the great "heliolithic" pathway and belong to the great culture-complex which travelled by it.

But there are several interesting bits of corroborative evidence that I cannot refrain from mentioning.

One of the most carefully-investigated bonds of cultural connection between the Eastern Mediterranean in Phœnician times and pre-Columbian America (Tehuantepec) has recently been put on record by Zelia Nuttall in her memoir on "a curious survival in Mexico of the use of the *Purpura* shell-fish for dyeing" (50). After a very thorough and critical analysis of all the facts of this truly remarkable case of transmission of an extraordinary custom, Mrs. Nuttall justly concludes that "it seems almost easier to believe that certain elements of an ancient European culture were at one time, and perhaps once only,

actually transmitted by the traditional small band of . . . Mediterranean seafarers, than to explain how, under totally different conditions of race and climate, the identical ideas and customs should have arisen" (pp. 383 and 384). Nor does she leave us in any doubt as to the route taken by the carriers of this practice. Found in association with it, both in the Old and the New World, was the use of conch-shell trumpets and pearls. The antiquity of these usages is proved by their representation in pre-Columbian pictures or, in the case of the pearls, the finding of actual specimens in graves.

In Phœnician, Greek, and later times these shell-trumpets were extensively used in the Mediterranean: "European travellers have found them in actual use in East India, Japan and, by the Alfurs, in Ceram, the Papuans of New Guinea, as well as in the South Sea islands as far as New Zealand," and in many places in America (p. 378). "In the Old and the New World alike, are found, in the same close association, (1) the purple industry and skill in weaving; (2) the use of pearls and conch-shell trumpets; (3) the mining, working and trafficking in copper, silver and gold; (4) the tetrarchial form of government; (5) the conception of 'Four Elements'; (6) the cyclical form of calendar. Those scholars who assert that all of the foregoing must have been developed independently will ever be confronted by the persistent and unassailable fact that, throughout America, the aborigines unanimously disclaim all share in their production and assign their introduction to strangers of superior culture from distant and unknown parts" (p. 383).

Many other equally definite proofs might be cited of the transmission of customs from the Old to the New World, of which the instance reported by Tylor (102) is

the classical example²; but I know of no other which has been so critically studied and so fully recorded as Mrs. Nuttall's case.

But the difficulty may be raised—as in fact invariably happens when these subjects come up for discussion—as to the means of transmission. Rivers has explained what does actually happen in the contact of peoples (68) and how a small group of wanderers bringing the elements of a higher culture can exert a profound and far-reaching influence upon a large uncultured population (64 to 70).

Lane-Fox's [Pitt Rivers'] memoir "on Early Modes of Navigation" (21) not only affords in itself an admirable summary of the definite evidence for the spread of culture; but is also doubly valuable to us, because incidentally it illustrates also the actual means by which the migrations of the culture-bearers took place. The survival into modern times, upon the Hooghly and other Indian rivers, of boats provided with the fantastic steering arrangement used by the Ancient Egyptians 2000 years B.C., is in itself a proof of ancient Egyptian influence in India; and the contemporary practice of representing eyes upon the bow of the ship enables us to demonstrate a still wider extension of that influence, for in modern times that custom has been recorded as far apart as Malta, India, China, Oceania and the North-West American coast.

But there is no difficulty about the question of the

² Tylor ("On the Game of Patolli," *Journ. Anthropol. Inst.*, Vol. VIII., 1879, p. 128) cites another certain case of borrowing on the part of pre-Columbian America from Asia. "Lot-backgammon as represented by tab, *pachisi*, etc., ranges in the Old World from Egypt across Southern Asia to Birma. As the *patolli* of the Mexicans is a variety of lot-backgammon most nearly approaching the Hindu *pachisi*, and perhaps like it passing into the stage of dice-backgammon, its presence seems to prove that it had made its way across from Asia. At any rate, it may be reckoned among elements of Asiatic culture traceable in the old Mexican civilization, the high development of which . . . seems to be in large measure due to Asiatic influence."

transmission of such customs. Most scholars who have mastered the early history of some particular area, in many cases those who most resolutely deny even the possibility of the wider spread of culture, frankly admit—because it would stultify their own localised researches to deny it—the intercourse of the particular people in which they are interested and its neighbours. Merely by using these links, forged by the reluctant hands of hostile witnesses, it is possible to construct the whole chain needed for such migrations as I postulate (see *Map II.*).

No one who reads the evidence collected by such writers as Ellis (15), de Quatrefages (60) and Percy Smith (98)³ can doubt the fact of the extensive prehistoric migrations throughout the Pacific Ocean along definitely known routes. Even Joyce (whose otherwise excellent summaries of the facts relating to American archæology have been emasculated by his refusal to admit the influence of the Old World upon American culture) states that migrations from India extended to Indonesia (and Madagascar) and all the islands of the Pacific; and even that “it is likely that the coast of America was reached” (61, p. 119).⁴

There is no doubt as to the reality of the close maritime intercourse between the Persian Gulf and India from the eighth century B.C. (13; 14; 51; and 101); and of course it is a historical fact that the Mediterranean littoral and Egypt had been in intimate connexion with Babylonia for some centuries before, and especially after, that time.

In the face of this overwhelming mass of definite

³ See also 2; 3; 7; 8; 9; 10; 16; 20; 21; 24; 29; 30; 38; 48; 49; 50; 51; 61; 73; 103; and 105.

⁴ For proof that it was reached see 3; 8; 9; 10; 20; 21; 38; 49; 50; 51; 73; 102; 103; and 105.



Map 2.—An attempt to represent roughly the areas more directly affected by the "heliolithic" culture-complex, with arrows to indicate the hypothetical routes taken in the migrations of the culture-bearers who were responsible for its diffusion.

evidence of the reality not only of the spread of culture and its carriers, but also of the ways and the means by which it travelled, it will naturally be asked how it has come to pass that there is even the shadow of a doubt as to the migrations which distributed this "heliolithic" culture-complex so widely in the world. It cannot be explained by lack of knowledge, for most of the facts that I have enumerated are taken bodily from the anthropological journals of forty or more years ago.

The explanation is to be found, I believe, in a curious psychological process incidental to the intensive study of an intricate problem. As knowledge increased and various scholars attempted to define the means by (and the time at) which the contacts of various peoples took place, difficulties were revealed which, though really trivial, were magnified into insuperable obstacles. All of these real difficulties were created by mistaken ideas of the relative chronology of the appearance of civilisation in various centres, and especially by the failure to realise that useful arts were often lost. For example, if on a certain mainland *A* two practices, *a* and *b*—one of them, *a*, a useful practice, say the making of pottery; the other, *b*, a useless custom, say the preservation of the corpse—were developed, and *a* was at least as old, or preferably definitely older than *b*, it seemed altogether inconceivable to the ethnologist if an island *B* was influenced by the culture of the mainland *A*, at some time after the practices *a* and *b* were in vogue, that it might, under any conceivable circumstances, fail to preserve the useful art *a*, even though it might allow the utterly useless practice *b* to lapse. Therefore it was argued that, if the later inhabitants of *B* mummified their dead, but did not make pottery, this was clear evidence that they could not have come under the influence of *A*.

But the whole of the formidable series of obstacles raised by this kind of argument has been entirely swept away by Dr. Rivers, who has demonstrated how often it has happened that a population has completely lost some useful art which it once had, and even more often clung to some useless practice (65).

The remarkable feature of the present state of the discussion is that, in spite of Rivers' complete demolition of these difficulties (65), most ethnologists do not seem to realise that there is now a free scope for taking a clear and common-sense view of the truth, unhindered by any obstructions. It is characteristic of the history of scientific, no less than of theological argument, that the immediate effect of the destruction of the foundations of cherished beliefs is to make their more fanatical votaries shout their creed all the louder and more dogmatically, and hurl anathemas at those who dissent.

This is the only explanation I can offer of the remarkable presidential address delivered by Fewkes to the Anthropological Society of Washington in 1912 (18), Keane's incoherent recklessness⁵ (41, pp. 140, 218, 219, and 367 to 370), and the amazing criticisms which during the last four years I have had annually to meet. There is no attempt at argument, but mere dogmatic and often irrelevant assertions. The constant appeal to the meaningless phrase "the similarity of the working of the

⁵ Dr. Fewkes' discourse is essentially a farrago of meaningless verbiage. Later on in this communication I shall give a characteristic sample of the late Professor Keane's dialectic; but the whole of the passages referred to should be read by anyone who is inclined to cavil at my strictures upon such expositions of modern ethnological doctrine. The obvious course for any serious investigator to pursue is to ignore such superficial and illogical pretensions: but the ethnological literature of this country and America is so permeated with ideas such as Fewkes and Keane express, that it has become necessary bluntly to expose the utter hollowness of their case.

human mind”⁶ (18), as though it were a magical incantation against logical induction, and harping on the so-called “psychological argument” (41), which is directly opposed to the teaching of psychology, are the only excuses one can obtain from the “orthodox” ethnologist for this obstinate refusal to face the issue. Of course it is a historical fact that the discussions of the theory of evolution inclined ethnologists during the last century the more readily to accept the *laissez faire* attitude, and put an end to all their difficulties by the pretence that most cultures developed independently *in situ*. It is all the more surprising that Huxley took some small part in encouraging this lapse into superficiality and abuse of the evolution conception, when it is recalled that, as Sir Michael Foster tells us, the then President of the Ethnological Society “made himself felt in many ways, not the least by the severity with which he repressed the pretensions of shallow persons who, taking advantage of the glamour of the Darwinian doctrine, talked nonsense in the name of anthropological science” (“Life and Letters of Thomas Henry Huxley,” Vol. I., p. 263).

It is a singular commentary on the attitude of the “orthodox” school of ethnologists that, when pressed to accept the obvious teaching of ethnological evidence, they

⁶ For if any sense whatever is to be attached to this phrase it implies that man is endowed with instincts of a much more complex and highly specialised kind than any insect or bird—instincts moreover which impel a group of men to perform at the same epoch a very large series of peculiarly complex, meaningless and fantastic acts that have no possible relationship to the “struggle for existence,” which is supposed to be responsible for the fashioning of instincts.

But William McDougall tells us that the distinctive feature of human instincts is that they are of “the most highly general type.” “They merely provide a basis for vaguely directed activities in response to vaguely discriminated impressions from large classes of objects.” (“Psychology, the Study of Behaviour,” p. 171.) There is nothing vague about the extraordinary repertoire of the “heliolithic” cult!

should desert the strong intrenchments which the difficulties of full and adequate explanation have afforded them in the past, and take refuge behind the straw barricades of imaginary psychological and biological analogies, which they have hastily constructed for their own purposes, and in flagrant defiance of all that the psychologist understands by the phrase "working of the human mind," if perchance he is ever driven to employ this expression, or the meaning attached by the biologist to "evolution."

It is not sufficient proof of my thesis, however, merely to expose the hollowness of the pretensions of one's opponents, nor even to show the identity of geographical distribution and the linking up of customs to form the "heliolithic" culture-complex. Many writers have dimly realised that some such spread of culture took place, but by misunderstanding the nature of the factors that came into play or the chronology of the movements they were discussing (see especially Macmillan Brown's [7] and Enoch's [16] books, to mention the latest, but by no means the worst offenders), have brought discredit upon the thesis I am endeavouring to demonstrate.

Another danger has arisen out of the revulsion against Bastian's old idea of independent evolution by his fellow-countrymen Frobenius, Graebner, Ankermann, Foy and others, with the co-operation of the Austrian philologist, Schmidt, and the Swiss ethnologist, Montandon (who has summarised the views of the new school in the first part of the new journal, *Archives suisses d'Anthropologie générale*, May, 1914, p. 113); for they have rushed to the other extreme, and, relying mainly upon objects of "material culture," have put forward a method of analysis and postulated a series of migrations for which the evidence is very doubtful. Rivers (64) has pointed out the unreliability of such inferences when unchecked by the con-

sideration of elements of culture which are not so easily bartered or borrowed as bows and spears. He has insisted upon the fundamental importance of the study of social organisation as supplying the most stable and trustworthy data for the analysis of a culture-complex and an index of racial admixture. The study of such a practice as mummification, the influence of which is deep-rooted in the innermost beliefs of the people who resort to it, affords data almost as reliable as Rivers' method ; for the subsequent account will make it abundantly clear that the practice of embalming leaves its impress upon the burial customs of a people long ages after other methods of disposal of their dead have been adopted.

I have been led into this digression by attempting to make it clear that the mere demonstration of the identity of geographical distribution and the linking together of a series of cultural elements by no means represents the solution of the main problem.

What has still to be elucidated is the manner and the place in which the complex fabric of the "heliolithic" culture was woven, the precise epoch in which it began to be spread abroad and the identity of its carriers, the influences to which it was subjected on the way, and the additions, subtractions and modifications which it underwent as the result.

Although I have now collected many of the data for the elucidation of these points, the limited space at my disposal compels me to defer for the present the consideration of the most interesting aspect of the whole problem, the identity of the early mariners who were the distributors of so strange a cargo. It was this aspect of the question which first led me into the controversy ; but I shall be able to deal with it more conveniently when the ethnological case has been stated. The enormous

bulk of the data that have accumulated compels me to omit a large mass of corroborative evidence of an ethnological nature; but no doubt there will be many opportunities in the near future for using up this reserve of ammunition.

Before setting out for the meeting of the British Association in Australia last year I submitted the following abstract of a communication (96) to be made to the Section of Anthropology:—

“After dealing with the evidence from the resemblances in the physical characteristics of widely separated populations—such, for instance, as certain of the ancient inhabitants of Western Asia on the one hand, and certain Polynesians on the other—suggesting far-reaching prehistoric migrations, the distribution of certain peculiarly distinctive practices, such as mummification and the building of megalithic monuments, is made use of to confirm the reality of such wanderings of peoples.

“I have already (at the Portsmouth, Dundee, and Birmingham meetings) dealt with the problem as it affects the Mediterranean littoral and Western Europe. On the present occasion I propose to direct attention mainly to the question of the spread of culture from the centres of the ancient civilisations along the Southern Asiatic coast and from there out into the Pacific. From the examination of the evidence supplied by megalithic monuments and distinctive burial customs, studied in the light of the historical information relating to the influence exerted by Arabia and India in the Far East, one can argue by analogy as to the nature of migrations in the even more remote past to explain the distribution of the earliest peoples dwelling on the shores of the Pacific.

“Practices such as mummification and megalith-building present so many peculiar and distinctive features

that no hypothesis of independent evolution can seriously be entertained in explanation of their geographical distribution. They must be regarded as evidence of the diffusion of information, and the migrations of bearers of it, from somewhere in the neighbourhood of the Eastern Mediterranean, step by step out into Polynesia, and even perhaps beyond the Pacific to the American littoral."

At that time it was my intention further to develop the arguments from megalithic monuments which I had laid before the Association at the three preceding meetings and elsewhere (90; 91; 92; 93; and especially 94); and endeavour to prove that the structure and the geographical distribution of these curious memorials pointed to the spread of a distinctive type of culture along the Southern Asiatic littoral, through Indonesia and Oceania to the American Continent. The geographical distribution of the practice of mummification was to have been used merely as a means of corroboration of what I then imagined to be the more complete megalithic record, and of emphasizing the fact that Egypt had played some part at least in originating these curiously linked customs.

But when I examined the mummy from Torres Straits in the Macleay Museum (University of Sydney), and studied the literature relating to the methods employed by the embalmers in that region (1; 19; 25; and 27), I was convinced, from my knowledge of the technical details used in mummification in ancient Egypt (see especially 78; 86 and 87), that these Papuan mummies supplied us with the most positive demonstration of the Egyptian origin of the methods employed. Moreover, as they revealed a series of very curious procedures, such as were not invented in Egypt until the time of the New Empire, and some of them not until the XXIst Dynasty, it was evident that the cultural wave which carried the

knowledge of these things to the Torres Straits could not have started on its long course from Egypt before the ninth century B.C., at the earliest.

The incision for eviscerating the body was made in the flank, right or left, or in the perineum (19; 25)—the two sites selected for making the embalming incision in Egypt (78); the flank incision was made in the precise situation (between costal margin and iliac crest) which was distinctive of XXIst and XXIInd Dynasty methods in Egypt (86); and the wound was stitched up in accordance with the method employed in the case of the cheaper kinds of embalming at that period (78). When the flank incision was not employed an opening was made in the perineum, as was done in Egypt—the second method mentioned by Herodotus—in the case of less wealthy people (56, p. 46).

The viscera, after removal, were thrown into the sea, as, according to Porphyry and Plutarch, it was the practice in Egypt at one time (56, pp. 57 and 58) to cast them into the Nile.

The body was painted with a mixture containing red-ochre, the scalp was painted black, and artificial eyes were inserted. These procedures were first adopted (in their entirety) in Egypt during the XXIst Dynasty, although the experiments leading up to the adoption of these methods began in the XIXth.

But most remarkable of all, the curiously inexplicable Egyptian procedure for removing the brain, which in Egypt was not attempted until the XVIIIth Dynasty—*i.e.*, until its embalmers had had seventeen centuries experience of their remarkable craft (78)—was also followed by the savages of the Torres Straits (25; 27)!

Surely it is inconceivable that such people could have originated the idea or devised the means for practising an

operation so devoid of meaning and so technically difficult as this! The interest of their technique is that the Torres Straits operators followed the method originally employed in Egypt (in the case of the mummy of the Pharaoh Ahmes I. [86, p. 16]), which is one requiring considerable skill and dexterity, and not the simpler operation through the nostrils which was devised later (78).

The Darnley Islanders also made a circular incision through the skin of each finger and toe, and having scraped off the epidermis from the rest of the body, they carefully peeled off these thimbles of skin, and presented them to the deceased's widow (25 ; 27).

This practice is peculiarly interesting as an illustration of the adoption of an ancient Egyptian custom in complete ignorance of the purpose it was intended to serve. The ancient Egyptian embalmers (and, again, those of the XXIst Dynasty) made similar circular incisions around fingers and toes, and also scraped off the rest of the epidermis: but the aim of this strange procedure was to prevent the general epidermis, as it was shed (which occurred when the body was steeped for weeks in the preservative brine bath), from carrying the finger- and toe-nails with it (78). A thimble of skin was left on each finger and toe to keep the nail *in situ*; and to make it doubly secure, it was tied on with string (78) or fixed with a ring of gold or a silver glove (84).

In the Torres Straits method of embalming the brine bath was not used; so the scraping off of the epidermis was wholly unnecessary. In addition, after following precisely the preliminary steps of this aimless proceeding, by deliberately and intentionally removing the skin-thimbles and nails they defeated the very objects which the Egyptians had in view when they invented this operation!

An elaborate technical operation such as this which serves no useful purpose and is wholly misunderstood by its practitioners cannot have been invented by them. It is another certain proof of the Egyptian origin of the practice.

There is another feature of these Papuan mummies which may or may not be explicable as the adoption of Egyptian practices put to a modified, if not a wholly different, use. Among the new methods introduced in Egypt in the XXIst Dynasty was a curious device for restoring to the mummy something of the fulness of form and outline it had lost during the process of preservation. Through various incisions (which incidentally no doubt allowed the liquid products of decomposition to escape) foreign materials were packed under the skin of the mummy (78; 87). These incisions were made between the toes, sometimes at the knees, in the region of the shoulders, and sometimes in other situations (78). In the Papuan method of mummification "cuts were made on the knee-caps and between the fingers and toes; then holes were pierced in the cuts with an arrow so as to allow the liquids to drip from them" (Hamlyn-Harris, 27, p. 3). In one of the mummies in the Brisbane museum there seem to be incisions also in the shoulders. The situation of these openings suggests the view that the idea of making them *may* (and I do not wish to put it any more definitely) have been suggested by the Egyptian XXIst Dynastic practice. For, although the incisions were made, in the latter case, for the purpose of packing the limbs, incidentally they served for drainage purposes.

But it was not only the mere method of embalming, convincing and definite as it is, that establishes the derivation of the Papuan from the Egyptian procedure; but

also all the other funerary practices, and the beliefs associated with them, that help to clinch the proof. The special treatment of the head, the use of masks, the making of stone idols, these and scores of other curious customs (which have been described in detail in Haddon's and Myers' admirable account [25]) might be cited.

When I called the attention of the Anthropological Section to these facts and my interpretation of them at the meeting of the British Association in Melbourne, Professor J. L. Myers opened the discussion by adopting a line of argument which, even after four years' experience of controversies of the megalith-problem, utterly amazed me. "What more natural than that people should want to preserve their dead? Or that in doing so they should remove the more putrescible parts? Would not the flank be the natural place to choose for the purpose? Is it not a common practice for people to paint their dead with red-ochre?" It is difficult to believe that such questions were meant to be taken seriously. The claim that it is quite a natural thing on the death of a near relative for the survivors instinctively to remove his viscera, dry the corpse over a fire, scrape off his epidermis, remove his brain through a hole in the back of his neck, and then paint the corpse red is a sample of casuistry not unworthy of a mediæval theologian. Yet this is the gratuitous claim made at a scientific meeting! If Professor Myers had known anything of the history of Anatomy he would have realized that the problem of preserving the body was one of extreme difficulty which for long ages had exercised the most civilized peoples, not only in antiquity, but also in modern times. In Egypt, where the natural conditions favouring the successful issue of attempts to preserve the body were largely responsible for the possibility of such embalming, it took more than seventeen

centuries of constant practice and experimentation to reach the stage and to acquire the methods exemplified in the Torres Straits mummies. In Egypt also a curious combination of natural circumstances and racial customs was responsible for the suggestion of the desirability and the possibility artificially to preserve the corpse. How did the people of the Torres Straits acquire the knowledge even of the possibility of such an attainment, not to mention the absence of any inherent suggestion of its desirability? For in the hot, damp atmosphere of such places as Darnley Island the corpse would never have been preserved by natural means, so that the suggestion which stimulated the Egyptians to embark upon their experimentation was lacking in the case of the Papuans. But even if for some mysterious reasons these people had been prompted to attempt to preserve their dead, during the experimental stage they would have had to combat these same unfavourable conditions. Is it at all probable or even possible to conceive that under such exceptionally difficult, not to say discouraging, circumstances they would have persisted for long periods in their gruesome experiments; or have attained a more rapid success than the more cultured peoples of Egypt and Europe, operating under more favourable climatic conditions, and with the help of a knowledge of chemistry and physics, were able to achieve? The suggestion is too preposterous to call for serious consideration.

But if for the moment we assume that the Darnley Islander instinctively arrived at the conclusion that it was possible to preserve the dead, that he would rather like to try it, and that by some mysterious inspiration the technical means of attaining this object was vouchsafed him, why, when the whole ventral surface of the body was temptingly inviting him to operate by the simplest

and most direct means, did he restrict his choice to the two most difficult sites for his incision? We know why the Egyptian made the opening in the left flank and in other cases in the perineum; but is it likely the Papuan, once he had decided to cut the body, would have had such a respect for the preservation of the integrity of the front of the body as to impel him to choose a means of procedure which added greatly to the technical difficulty of the operation? We have the most positive evidence that the Papuan had no such design, for it was his usual procedure to cut the head off the trunk and pay little further attention to the latter. Myres' contention will not stand a moment's examination.

As to the use of red-ochre, which Myres rightly claimed to be so widespread, no hint was given of the possibility that it might be so extensively practised simply because the Egyptian custom had spread far and wide.

It is important to remember that the practice of painting stone statues with red-ochre (obviously to make them more life-like) was in vogue in Egypt before 3000 B.C.; and throughout the whole "heliolithic" area, wherever the conception of human beings dwelling in stones, whether carved or not, was adopted, the Egyptian practice of applying red paint also came into vogue. But it was not until more than twenty centuries later—*i.e.* when, for quite definite reasons in the XXIst Dynasty, the Egyptians conceived the idea of converting the mummy itself into a statue—that they introduced the procedure of painting the mummy (the actual body), simply because it was regarded as the statue (78).

After Professor Myres, Dr. Haddon offered two criticisms. Firstly, the incisions in the feet and knees were not suggested by Egyptian practices, but were

made for the strictly utilitarian purpose of draining the fluids from the body. I have dealt with this point already (*vide supra*). His second objection was that there were no links between Egypt and Papua to indicate that the custom had spread. The present communication is intended to dispose of that objection by demonstrating not only the route by which, but also how, the practice reached the Torres Straits after the long journey from Egypt.

It will be noticed that this criticism leaves my main arguments from the mummies quite untouched. Moreover, the fact that originally I made use of the testimony of the mummies merely in support of evidence of other kinds (the physical characters of the peoples and the distribution of megalithic monuments) was completely ignored by my critics.

But, as I have already remarked, it is not merely the remarkable identity of so many of the peculiar features of Papuan and Egyptian embalming that affords definite evidence of the derivation of one from the other; but in addition, many of the ceremonies and practices, as well as the traditions relating to the people who introduced the custom of mummification, corroborate the fact that immigrants from the west introduced these elements of culture. In addition, they also suggest their affinities.

"A hero-cult, with masked performers and elaborate dances, spread from the mainland of New Guinea to the adjacent islands: part of this movement seems to have been associated with a funeral ritual that emphasised a life after death. . . . Most of the funeral ceremonies and many sacred songs admittedly came from the west" (Haddon, 25, p. 45).

"Certain culture-heroes severally established themselves on certain islands, and they or their followers

introduced a new cult which considerably modified the antecedent totemism," and taught "improved methods of cultivation and fishing" (p. 44).

"An interesting parallel to these hero-cults of Torres Straits occurred also in Fiji. The people of Viti-Levu trace their descent from [culture-heroes] who drifted across the Big Ocean and taught to the people the cult associated with the large stone enclosures" (p. 45).

In these islands the people were expert at carving stone idols and they had legends concerning certain "stones that once were men" (p. 11). It is also significant that at the bier of a near relative, boys and girls, who had arrived at the age of puberty, had their ears pierced and their skin tattooed (p. 154).

Thus Haddon himself supplies so many precise tokens of the "heliolithic" nature of the culture of the Torres Straits.

These hints of migrations and the coming of strangers bringing from the west curious practices and beliefs may seem at first sight to add little to the evidence afforded by the technique of the embalming process; but the subsequent discussion will make it plain that the association of these particular procedures with mummification serves to clinch the demonstration of the source from which that practice was derived.

It is doubly interesting to obtain all this corroborative evidence from the writings of Dr. Haddon, in view of the fact, to which I have already referred, that he vigorously protested against my contention that the embalmers of the Torres Straits acquired their art, directly or indirectly, from Egypt. For, in his graphic account of a burial ceremony at Murray Islands, his confession that, as he watched the funerary boat and the wailing women, his "mind wandered back thousands of years, and called up

ancient Egypt carrying its dead in boats across the sacred Nile" has a much deeper and more real significance than he intended. The analogy which at once sprang to his mind was not merely a chance resemblance, but the expression of a definite survival amongst these simple people in the Far East of customs their remote ancestors had acquired, through many intermediaries no doubt, from the Egyptians of the ninth century B.C.

At the time when Dr. Haddon asked for the evidence for the connection between Egypt and Papua, I was aware only of the Burmese practices (*vide infra*) in the intervening area, and the problem of establishing the means by which the Egyptian custom actually spread seemed to be a very formidable task.

But soon after my return from Australia all the links in the cultural chain came to light. Mr. W. J. Perry, who had been engaged in analysing the complex mixture of cultures in Indonesia, kindly permitted me to read the manuscript of the book he had written upon the subject. With remarkable perspicuity he had unravelled the apparently hopeless tangle into which the social organisation of this ethnological cockpit has been involved by the mixture of peoples and the conflict of diverse beliefs and customs. His convincing demonstration of the fact that there had been an immigration into Indonesia (from the West) of a people who introduced megalithic ideas, sun-worship and phallism, and many other distinctive practices and traditions, not only gave me precisely the information I needed, but also directed my attention to the fact that the culture (for which, so he informed me, Professor Brockwell, of Montreal, had suggested the distinctive term "heliolithic") included also the practice of mummification. In the course of continuous discussions with him during the last four months a clear view of the whole

problem and the means of solving most of its difficulties emerged.

For Perry's work in this field, no less than for my own, Rivers' illuminating and truly epoch-making researches (64 to 70) have cleared the ground. Not only has he removed from the path of investigators the apparently insuperable obstacles to the demonstration of the spread of cultures by showing how useful arts can be lost (65); but he has analysed the social organisation of Oceania in such a way that the various waves of immigration into the Pacific can be identified and with certainty be referred back to Indonesia (69). Many other scholars in the past have produced evidence (for example 2; 60; 61 and 98) to demonstrate that the Polynesians came from Indonesia; but Rivers analysed and defined the characteristic features of several streams of culture which flowed from Indonesia into the Pacific. Perry undertook the task of tracing these peoples through the Indonesian maze and pushing back their origins to India. In the present communication I shall attempt to sketch in broad outline the process of the gradual accumulation in Egypt and the neighbourhood of the cultural outfit of these great wanderers, and to follow them in their migrations west, south and east from the place where their curious assortment of customs and accomplishments became fortuitously associated one with the other (*Map II.*).

I cannot claim that my colleagues in this campaign against what seems to us to be the utterly mistaken precepts of modern ethnology see altogether eye to eye with me. They have been dealing exclusively with more primitive peoples amongst whom every new attainment, in arts and crafts, in beliefs and social organisation, in everything in fact that we regard as an element of civili-

zation, has been introduced from without by more cultured races, or fashioned in the conflict between races of different traditions and ideals.

My investigations, on the contrary, have been concerned mainly with the actual invention of the elements of civilization and with the people who created practically all of its ingredients—the ideas, the implements and methods of the arts and crafts which give expression to it. Though superficially my attitude may seem to clash with theirs, in that I am attempting to explain the primary origin of some of the things, with which they are dealing only as ready-made customs and beliefs that were handed on from people to people, there is no real antagonism between us.

It is obvious that there must be a limit to the application of the borrowing-explanation; and when we are forced to consider the people who really invented things, it is necessary to frame some working hypothesis in explanation of such achievements, unless we feebly confess that it is useless to attempt such enquiries.

In previous works (82 and 85) I have explained why it must be something more than a mere coincidence that in Egypt, where the operation of natural forces leads to the preservation of the corpse when buried in the hot dry sand, it should have become a cardinal tenet in the beliefs of the people to strive after the preservation of the body as the essential means of continuing an existence after death. When death occurred the only difference that could be detected between the corpse and the living body was the absence of the vital spirit from the former. [For the interpretation of the Egyptians' peculiar ideas concerning death, see Alan Gardiner's important article (23).] It was in a condition in some sense analogous to sleep; and the corpse, therefore, was placed in its "dwell-

ling" in the soil lying in the attitude naturally assumed by primitive people when sleeping. Its vital spirit or *ka* was liberated from the body, but hovered round the corpse so long as its tissues were preserved. It needed food and all the other things that ministered to the welfare and comfort of the living, not omitting the luxuries and personal adornments which helped to make life pleasant. Hence at all times graves became the objects of plunder on the part of unscrupulous contemporaries; and so incidentally the knowledge was forthcoming from time to time of the fate of the body in the grave.

The burial customs of the Proto-Egyptians, starting from those common to the whole group of the Brown Race in the Neolithic phase, first became differentiated from the rest when special importance came to be attached to the preservation of the actual tissues of the body.

It was this development, no doubt, that prompted their more careful arrangements for the protection of the corpse, and gradually led to the aggrandisement of the tomb, the more abundant provision of food offerings and funerary equipment in general.

Even in the earliest known Pre-dynastic period the Proto-Egyptians were in the habit of loosely wrapping their dead in linen—for the art of the weaver goes back to that remote time in Egypt—and then protecting the wrapped corpse from contact with the soil by an additional wrapping of goat-skin or matting.

Then, as the tomb became larger, to accommodate the more abundant offerings, almost every conceivable device was tried to protect the body from such contact. Instead of the goat-skin or matting, in many cases the same result was obtained by lining the grave with series of sticks, with slabs of wood, with pieces of unhewn stone, or by lining the grave with mud-bricks. In other cases,

again, large pottery coffins, of an oblong, elliptical, or circular form, were used. Later on, when metal implements were invented (90), and the skill to use them created the crafts of the carpenter and stonemason, coffins of wood or stone came into vogue. It is quite certain that the coffin and sarcophagus were Egyptian inventions. The mere fact of this extraordinary variety of means and materials employed in Egypt, when in other countries one definite method was adopted, is proof of the most positive kind that these measures for lining the grave were actually invented in Egypt. For the inventor tries experiments: the borrower imitates one definite thing. During this process of gradual evolution, which occupied the whole of the Pre- and Proto-dynastic periods, the practice of inhumation (in the strict sense of the term) changed step by step into one of burial in a tomb. In other words, instead of burial in the soil, the body came to be lodged in a carefully constructed subterranean chamber, which no longer was filled up with earth. The further stages in this process of evolution of tomb construction, the way in which the rock-cut tomb came into existence, and the gradual development of the stone superstructure and temple of offerings—all of these matters have been summarised in some detail in my article on the evolution of megalithic monuments (94).

What especially I want to emphasize here is that in Egypt is preserved every stage in the gradual transformation of the burial customs from simple inhumation into that associated with the fully-developed rock-cut tomb and the stone temple. There can be no question that the craft of the stonemason and the practice of building megalithic monuments originated in Egypt. In addition, I want to make it quite clear that there is the most intimate genetic relationship between the develop-

ment of these megalithic practices and the origin of the art of mummification.

For in course of time the early Egyptians came to learn, no doubt again from the discoveries of their tomb-robbers, that the fate of the corpse, after remaining for some time in a roomy rock-cut tomb or stone coffin, was vastly different from that which befell the body when simply buried in the hot, dry, desiccating sand. In respect of the former they acquired the idea which the Greeks many centuries later embalmed in the word "sarcophagus," under the simple belief that the disappearance of the flesh was due to the stone in some mysterious way devouring it.⁷ [Certain modern archæologists within recent years have entertained an equally child-like, though even less informed, view when they claimed the absence of any trace of the flesh in certain stone sarcophagi as evidence in favour of a fantastic belief that the Neolithic people of the Mediterranean area were addicted to the supposed practice which Italian archæologists call *scarnitura*.]

But by the time the discovery was made that bodies placed in more sumptuous tombs were no longer preserved as they were apt to be when buried in the sand, the idea of the necessity for the preservation of the body as the essential condition for the attainment of a future existence had become fixed in the minds of the people and established by several centuries of belief as *the* cardinal tenet of their faith. Thus the very measures they had taken the more surely to guard and preserve the sacred remains of their dead had led to a result the reverse of what had been intended.

⁷ It is a curious reflection that the idea of stone living which made such a fantastic belief possible may itself have arisen from the Egyptian practices about to be described.

The elaborate ritual that had grown up and the imposing architectural traditions were not abandoned when this discovery was made. Even in these modern enlightened days human nature does not react in that way. The cherished beliefs held by centuries of ancestors are not renounced for any discovery of science. The ethnologist has not given up his objections to the idea of the spread of culture, now that all the difficulties that militated against the acceptance of the common-sense view have been removed! Nor did the Egyptians of the Protodynastic period revert to the practices of their early ancestors and take to sand-burial again. They adopted the only other alternative open to a people who retained implicitly the belief in the necessity of preserving the body, *i.e.*, they set about attempting to attain by art what nature unaided no longer secured, so long as they clung to their custom of burying in large tombs. They endeavoured artificially to preserve the bodies of their dead.

This explains what I meant to imply when I said that the megalithic idea and the incentive to mummify the dead are genetically related, the one to the other. The stone-tomb came into existence as a direct result of the importance attached to the corpse. This development defeated the very object that inspired it. The invention of the art of embalming was the logical outcome of the attempt to remedy this unexpected result.

As in the history of every similar happening elsewhere, necessity, or what these simple-minded people believed to be a necessity, was the "mother of invention."

In the course of the following discussion it will be seen that the practice of mummification became linked up in another way with what may be called the megalithic traditions. The crudely-preserved body no longer retained any likeness to the person as his friends knew him

when alive. A life-like stone statue was therefore made to represent him. Magical means (p. 42) were adopted to give life to the statue. Thus originated the belief that a stone might become the dwelling of a living person ; and that a person when dead may become converted into stone. So insistent did this belief become that among more uncultured people, who borrowed Egyptian practices but were unable to make portrait statues, a rudely-shaped or even unhewn pillar of stone came to be regarded as the dwelling of the deceased.

Thus from being the mere device for the identification of the deceased the stone statue degenerated among less cultured people into an object even less like the dead man than his own crudely-made mummy. But the fundamental idea remained and became the starting point for that rich crop of petrification-myths and beliefs concerning men and animals living in stones.

Thus arose in Egypt, somewhere about 3000 B.C., the nucleus of the "heliolithic" culture-complex—mummification, megalithic architecture, and the making of idols, three practices most intimately and genetically linked one with the other. But it was the merest accident that the people amongst whom these customs developed, should also have been weavers of linen, workers in copper, worshippers of the sun and serpent, and practitioners of massage and circumcision.

But it was not for another fifteen centuries that the characteristic "heliolithic" culture-complex was completed by the addition of numerous other trivial customs, like ear-piercing, tattooing and the use of the swastika, none of which originated in Egypt, but happened to have become "tacked on" to that distinctive culture before its great world tour began.

The earliest unquestionable evidence (89) of an attempt

artificially to preserve the body was found in a rock-cut tomb of the Second Dynasty, at Sakkara. It is important to note that the body was lying in a *flexed* position upon the left side, and was contained in a short wooden coffin, modelled like a house. The limbs were wrapped separately and large quantities of fine linen bandages had been applied around all parts of the body, so as to mould the wrapped mummy to a life-like form.

Thus in the earliest mummy—or, to be strictly accurate, in the remains which exhibit the earliest evidence of the attempt at embalming—we find exemplified the two objects that the Ancient Egyptian embalmer aimed at throughout the whole history of his craft, viz., to preserve the actual tissues of the body, as well as the form and likeness of the deceased as he was when alive.

From the first the embalmer realised the limitations of his craftsmanship, *i.e.*, that he was unable to make the body itself lifelike. Hence he strove to preserve its tissues and then to make use of its wrappings for the purpose of fashioning a model or statue of the dead man. At first this was done while the body was flexed in the traditional manner. But soon the flexed position was gradually abandoned. Perhaps this change was brought about because it was easier to model the superficial form of a wrapped body when extended; and the greater success of the results so obtained may have been sufficiently important to have outweighed the restraining influence of tradition. The change may have occurred all the more readily at this time as beds were coming into use, and the idea of placing the “sleeping” body on a bed may have helped towards the process of extension.

But whatever view is taken of the explanation of the change of the attitude of the body, it is certain that it began soon after the first attempts at mummification

were made. The evidence of extended burials, referred to the First Dynasty, which were found by Flinders Petrie at Tarkhan (54), may seem to contradict this : but there are reasons for believing that attempts at embalming were being made even at that time (85). It seems to be definitely proved that this change was not due to any foreign influence (45). At the time that it occurred there was a very considerable alien element in the population of Egypt ; but the admixture took place long before the change in the position of the body was manifested. Perhaps the presence of a large foreign element may have weakened the sway of Egyptian tradition ; but the evidence seems definitely opposed to the inference that it played any active part in the change of custom. For the history of the gradual way in which the change was slowly effected is certain proof of the causal factors at work. There was no sudden adoption of the fully extended position, but a slow and very gradual straightening of the limbs—a process which it took centuries to complete. The analysis of the evidence by Mace is quite conclusive on this point (45).

I am strongly of the opinion that there is a causal relationship between this gradual extension of the body and the measures for the reconstruction of a lifelike model of the deceased, with the help of the mummy's wrappings. In other words, the adoption of the extended position was a direct result of the introduction of mummification.

At an early stage in the history of these changes it seems to have been realised that the likeness of the deceased which could be made of the wrapped mummy lacked the exactness and precision demanded of a portrait. Perhaps also there may have been some doubt as to the durability of a statue made of linen.

A number of interesting developments occurred at about this time to overcome these defects. In one case (85), found at Médum by Flinders Petrie, the superficial bandages were saturated with a paste of resin and soda, and the same material was applied to the surface of the wrappings, which, while still in a plastic condition, was very skilfully moulded to form a life-like statue. The resinous carapace thus built up set to form a covering of stony hardness. Special care was devoted to the modelling of the head (sometimes the face only) and the genitalia, no doubt to serve as the means of identifying the individual and indicating the sex respectively.

The hair (or, perhaps, it would be more correct to say, the wig) and the moustache were painted with a dark brown or black resinous mixture, and the pupils, eyelids and eyebrows were represented by painting with a mixture of malachite powder and resinous paste. In other cases, recently described by Junker (40), plaster was used for the same purpose as the resinous paste in Petrie's mummy. In two of the four instances of this practice found by Junker, only the head was modelled.

The special importance assigned to the head is one of the outstanding features of ancient Egyptian statuary. It was exemplified in another way in the tombs of the early part of the Old Kingdom, as Junker has recalled in his memoir, by the construction of stone portrait-statues of the head only, which were made life-size and placed in the burial chamber alongside the mummy. It seems to me that Junker overlooks an essential, if not the chief, reason for the special importance assigned to the head when he attributes it to the fact that the head contained the organs of sight, smell, hearing and taste. There can be no doubt that the head was modelled because it affords the chief means of recognising an individual. This por-

trayal of the features enabled any one, including the deceased's own *ka*, to identify the owner. Every circumstance of the making and the use of these heads bears out this interpretation, and no one has explained these facts more lucidly than Junker himself.

[Since the foregoing paragraphs have been put into print a preliminary report has come to hand from Professor Reisner, to whom I am indebted for most of my information regarding these portrait heads—*Museum of Fine Arts Bulletin*, Boston, April, 1915.]

At a somewhat later period in the Old Kingdom the making of these so-called "substitution-heads" was discontinued, and it became the practice to make a statue of the whole man (or woman), which was placed above-ground in the megalithic *serdab* within the *mastaba* (see 94). But even when the complete statue was made for the *serdab* the head alone was the part that was modelled with any approach to realism. In other words, the importance of the head as the chief means of identification was still recognised. Moreover, this idea manifested itself throughout the whole history of Egyptian mummification, for as late as the first century of the Christian era a portrait of the deceased was placed in front of the face of the mummy.

Thus in course of time the original idea of converting the wrapped body itself into a portrait-statue of the deceased was temporarily⁸ abandoned and the mummy was stowed away in the burial chamber at the bottom of a deep shaft, the better to protect it from desecration, while the portrait-statue was placed above ground, in a strong chamber (*serdab*), hidden in the *mastaba* (94).

⁸ How insistent the desire was to make a statue of the mummy itself is shown by the repeated attempts made in later times; see the account of the mummies of Amenophis III. (86) and of the rulers and priests of the XXIst and XXIInd Dynasties (78 and 87).

A certain magical value soon came to be attached to the statue in the *serdab*. It provided the body in which the *ka* could become reincarnated, and the deceased, thus reconstituted by magical means, could pass through the small hole in the *serdab* to enter the chapel of offerings and enjoy the food and the society of his friends there.

Dr. Alan Gardiner has kindly given me the following note in reference to this matter: "That statues in Egypt were meant to be efficient animate substitutes for the person or creature they portrayed has not been sufficiently emphasised hitherto. Over every statue or image were performed the rites of 'opening the mouth'—magical passes made with a kind of metal chisel in front of the mouth. Besides the *up-ro* 'mouth opening,' other words testify to the prevalence of the same idea; the word for 'to fashion' a statue (*ms*) is to all appearances identical with *ms* 'to give birth,' and the term for the sculptor was *sa' nkh*, 'he who causes to live.'"

As Blackman (5) has pointed out, the Pyramid Texts make it clear that libations were poured out and incense burnt before the statue or the mummy with the specific object of restoring to it the moisture and the odour respectively which the body had during life.

I have already indicated how, out of the conception of the possibility of bringing to life the stone portrait-statue, a series of curious customs were developed. Among peoples on a lower cultural plane, who were less skilled than the Egyptians in stone-carving, the making of a life-like statue was beyond their powers. Sometimes they made the attempt to represent the human form; in other cases crude representations of the breasts or suggestions of the genitalia were the only signs on a stone pillar to indicate that it was meant to represent a human statue: in many cases a simple uncarved block of stone was set

up. But the idea that such a pillar, whether carved or not, was the dwelling of some deceased person, seized the imagination and spread far and wide. It is seen in the Pygmalion and Galatea story, and its converse in the tragic history of Lot's wife. It is found throughout the Mediterranean area, the whole littoral of Southern Asia, Indonesia, the Pacific Islands and America, and can be regarded as definite evidence of the influence of the cult that developed in association with the practice of mummification.

It is necessary to emphasise that the making of portrait-statues was an outcome of the practice of mummification and an integral part of the cult associated with that burial custom. Hartland falls into grave error when he writes "where other peoples set up images of the deceased, those who practised desiccation or embalmment were enabled to keep the bodies themselves" (32, p. 418). It was precisely the people who embalmed or preserved the bodies of their dead who also made statues of them.

As these stones, according to such beliefs, could be made to hear and speak (23), they naturally became oracles. People were able to commune with and get advice and instruction from the kings and wise men who dwelt within these stone pillars. Thus it became the custom in many lands for meetings of special solemnity, such as those where important decisions had to be made, to be held at stone circles, where the members of the convention sat on the stones and communed with their ancestors, former rulers or wise men, who dwelt in the stones (or the grave) in the centre of the circle.

"Chardin, in his account of the stone circles he saw in Persia, mentions a tradition that they were used as places of assembly, each member of the council being

seated on a stone ; Homer, in his description of the shield of Achilles in the *Iliad*, speaks of the elders sitting in the place of justice upon stones in a circle ; Plot, in his account of the Rollrich stones in Oxfordshire, says that Olaus Wormius, Saxo Grammaticus, Meursius, and many other early historians, concur in stating that it was the practice of the ancient Danes to elect their kings in stone circles, each member of the council being seated upon a stone ; the tradition arising out of this custom, that these stones represent petrified giants, is widely spread in all countries where they occur, and Col. Forbes Leslie has shown that within the historic period, these circles were used in Scotland as places of justice" (Lane Fox, 20, p. 64). Is not our king crowned seated upon the Lia-fail, which is now in the coronation chair at Westminster? Such customs and beliefs are widespread also in India, Indonesia, and beyond, as W. J. Perry has pointed out. The practices still observed in the Khasia Hills in modern times clearly indicate the significance of this use of stone seats ; and the custom can be found from the Canary Islands in the West (26) to Costa Rica in the East, encircling the whole globe (compare "*Man*," May, 1915, p. 79).

I shall enter more fully into the consideration of the origin of the ideas associated with stone seats when Perry has published his important analysis of the significance of so curious a practice.

The converse of the belief in the bringing to life of stone statues—or perhaps it would be more correct to say, the complementary view that, if a stone can be converted into a living creature, the latter can also be transformed into stone—is found also wherever the parent belief is known to exist. As a rule it forms part of a complexly interwoven series of traditions concerning the creation,

the deluge, the destruction of the "sons of men" by petrification, and the re-peopling the earth by the incestuous intercourse of the "children of the gods."

Perry, who has made a study of the geographical distribution and associations of these curiously-linked traditions, has clearly demonstrated that they form an integral part of the cultural equipment of the sun-worshipping, stone-using peoples.

In the foregoing statement I have endeavoured to indicate also their genetic connection with the ideas that sprang from the early practice of mummification in Egypt.

There are many other curious features of the early Egyptian practices which might have served as straws to indicate how the cultural current had flowed, if much more substantial proofs had not been available of the reality of the movement. The diffusion of such a distinctive object as the Egyptian head-rest, which used to be buried with mummies of the Pyramid Age, is an example. It occurs widely spread in Africa, Southern Asia, Indonesia and the Pacific.

But the use of beds as funerary biers is a much more distinctive custom. The believers in theories of the independent evolution of customs may say "is it not natural to expect that people who regarded death as a kind of sleep should have placed head-rests and beds in the graves of their dead"? But how would such ethnologists explain the use of a funerary bier on the part of people (such as many of the less cultured people who adopted this Egyptian custom) who do not themselves use beds?

The evidence afforded by the use of biers is, in fact, a most definite demonstration of the diffusion of customs. Although it is a familiar scene in ancient Egyptian pictures to find the mummy borne upon a bed—a custom

which we know from Egyptian literature, no less than that of the Jews, Phœnicians, Greeks and Romans to have been actually observed—only one Egyptian cemetery, so far as I am aware—a proto-dynastic site, excavated by Flinders Petrie (54) at Tarkhan—has revealed corpses lying upon beds. But in a cemetery, some sixteen centuries later, excavated by Reisner in the Soudan (62), a similar practice was demonstrated. Garstang has recorded the observance of a similar custom further South (Meroe) at a later date.

These form useful connecting links with the region around the head-waters of the Nile, where even in modern times this practice has survived, and the mummified corpse of the king is placed upon a rough bier. I shall have occasion to point out later on that this curious practice spread from East Africa along the Asiatic littoral to Indonesia, Melanesia and Polynesia, thence to the American continent; and in most places was definitely associated with attempts at preservation of the corpse.

In many places along the whole course of the same great track, instead of a bed, a boat of some sort, usually a rough dug-out, was used. This practice also was observed in Egypt, where its symbolic purpose is clearly apparent.

Another distinctive feature of the burial customs in the same area was the idea that the grave represented the house in which the deceased was sleeping. How definitely this view was held by the proto-Egyptians is seen in their coffins, subterranean burial chambers, and the superstructures of their tombs, all three of which were originally represented as dwelling houses (see my memoir, 94).

The Pyramid texts clearly explain the precise significance and origin of the hitherto mysterious and wide-

spread custom of burning incense at the statue. For, as Blackman (5) has pointed out, the aim was by burning aromatic woods and resins thereby magically to restore to the "body" the odours of the living person.

It was therefore intimately related to the practice of mummification and genetically connected with it. It was part of the magical procedure for making the portrait-statue of the deceased (or later, in the time of the New Empire, the mummy itself) "an efficient animate substitute for the person" (Alan Gardiner).

A careful investigation of the geographical distribution of the custom of burning incense before the corpse and of the circumstances related to such a practice has convinced me that wherever it is found, even where no attempt is made to preserve the body, it can be regarded as an indication of the influence of the Egyptian custom of mummification. For apart from such an influence incense-burning is inexplicable. The attempt on the part of certain writers to explain the use of incense merely as a means of disguising the odours of putrefaction will not bear examination. It is an example of that kind of so-called psychological explanation which is opposed by all the ascertainable facts.

Beyond the borders of Egypt peoples who for a time adopted the custom of embalming and then for some reason, such as the failure to attain successful results or the adoption of conflicting beliefs or customs, allowed the practice to lapse, the simpler parts of the Egyptian funerary ritual often continued to be observed. The body was anointed with oil, perhaps packed in salt and aromatic plants, wrapped in linen or fine clothes, had incense burned before it, and was laid on a bed or special bier. All of these practices originated in Egypt and observance of any or all of them is to be regarded as a sure sign of

the influence of the Egyptian custom of mummification. Among the more immediate neighbours of the Egyptians, such as the Jews, Greeks and Romans, the evidence for this is clear. Occasionally the full process of embalming was followed, even if it were only a temporary procedure preliminary to the observance of some other burial custom, such as cremation, perhaps inspired by ideas wholly foreign to those which prompted mummification. I need not enumerate instances of this curious syncretism of burial customs, numerous examples of which will be found in Reutter (63, pp. 144-147) and in Hastings' Dictionary (32), as well as in the following pages.

At the very earliest period in Egypt from which historical records have come down to us (the time of the First Dynasty, 3200 B.C., or even earlier) "the king's favourite title was 'Horus,' by which he identified himself as the successor of the great god [the hawk sun-god] who had once ruled over the kingdom [other symbols often appeared] side by side with Buto, the serpent-goddess of the northern capital. As [the king] felt himself still as primarily king of Upper Egypt, it was not until later that he wore the serpent of the North, the sacred uraeus, upon his forehead" (Breasted, 6, p. 38). "The sun-disc, with the outspread wings of the hawk, became the commonest symbol of their religion" (p. 54). But in the time of the Fourth Dynasty "the priests of Heliopolis now demanded that [the king, who had always been represented as the successor of the sun-god and had borne the title 'Horus'] be the bodily son of Ré, who henceforth would appear on earth to become the father of the Pharaoh" (p. 122).

Now, when the Pharaoh thus became identified with the great sun-god Ré, his Pyramid-temple became the place of worship of the sun-god. Megalithic architecture

thus became indissolubly connected with sun-worship, simply from the accident of the invention of the art of building in stone—of erecting stone tombs, which were also temples of offerings—by a people who happened to be sun-worshippers and whose ruler's tomb became the shrine of the sun-god. I have already explained the close genetic connection between the practice of mummification and megalithic building.

The fact that the dominance of the sun-god Ré was attained in the northern capital, which was also the seat of serpent-worship, led to the association of the sun and the serpent.⁹ From this purely fortuitous blending of the sun's disc with the uraeus, often combined, especially in later times, with the wings of the Horus-hawk, a symbolism came into being which was destined to spread until it encircled the world, from Ireland to America. For an excellent example of this composite symbolism from America see Bancroft, 3, Vol. IV., p. 351. A more striking illustration of the completeness of the transference of a complex and wholly artificial design from Ancient Egypt to America could not be imagined. [For the full discussion of the original association of the sun and the serpent see Sethe's important *Memoir* (74).]

The chance circumstances which led to the linking together of all these incongruous elements—mummification, megalithic architecture, the idea of the king as son of the sun, sun and serpent worship and its curious symbolism—were created in Egypt, so that, wherever these peculiar customs or traditions make their appearance elsewhere in association the one with the other, it can confidently be regarded as a sure token of Egyptian influence, exerted directly or indirectly.

⁹ For an account of the geographical distribution of serpent-worship and a remarkable demonstration of the intimacy of its association with distinctive "heliolithic" ideas, see Wake, 103.

When certain modern ethnologists argue that it is the most natural thing in the world for primitive peoples to worship the sun as the obvious source of warmth and fertility, and therefore such worship can have no value as an indication of the contact of peoples, on general principles one might be prepared to admit the validity of the claim. But when it is realised that sun-worship, wherever it is found, is invariably associated with part (or the whole) of a large series of curiously incongruous customs and beliefs, it is no longer possible to regard the worship of the sun as having originated independently in several centres. Why should the sun-worshipper also worship the serpent and use a winged symbol, build megalithic monuments, mummify his dead, and practise a large series of fantastic tricks to which other peoples are not addicted? There is no inherent reason why a man who worships the sun should also tattoo his face, perforate his ears, practise circumcision, and make use of massage. In fact, until the time of the New Empire, the sun-worshipping Egyptian did not practise ear-piercing and tattooing, thereby illustrating the fact that originally these practices were not part of the cult, and that their eventual association with it was purely accidental. This only serves more definitely to confirm the view that it was the fortuitous association of a curious series of customs in Egypt at the time of the New Empire which supplied the cultural outfit of the "heliolithic" wanderers for their great migration.

In accordance with Egyptian beliefs "the sun was born every morning and sailed across the sky in a celestial barque, to arrive in the west and descend as an old man tottering into the grave" (Breasted, 6, p. 54).

The deceased might reach the west by being borne across in the sun-god's barque: friendly spirits, the four sons of Horus, might bring him a craft on which he might

float over: but by far the majority depended upon the services of a ferryman called "Turnface" (Breasted, p. 65).

In later times (Middle Kingdom) a model boat, fully equipped, was usually put in the tomb, "in order that the deceased might have no difficulty in crossing the waters to the happy isles." "By the pyramid of Sesostris III., in the sands of the desert, there were even buried five large Nile boats, intended to carry the king and his house across these waters" (Breasted, p. 176).

At a later period "the triumph of a Theban family brought with it the supremacy of Amon. . . . His essential character and individuality had already been obliterated by the solar theology of the Middle Kingdom, when he had become Amon-Re, and with some attributes borrowed from his ithyphallic neighbour, Min of Coptos, he now rose to a unique and supreme position of unprecedented splendour" (6, p. 248). Thus there was added to this "heliolithic" complex of ideas the definitely phallic element: but one must confess that this aspect of the culture did not become obtrusive until it was planted in alien lands, where among the Phœnicians and the peoples of India the phallic aspect became more strongly emphasised. From time to time various writers have striven to demonstrate a phallic motive in almost every element of the culture now under consideration. What I want to make clear is that it was a late addition, which was relatively insignificant in the original home of the culture.

After this digression I must now return to the further consideration of the mummies themselves.

Direct examination of the mummified bodies does not, of course, afford any certain evidence of the application of oil or fat to the surface of the body. Large quantities of fatty material were often found in the mouth and the

body cavity (78; 81 and 86); and the surface of the body was often greasy; but, of course, the fatty materials in the skin itself might have afforded a sufficient explanation of this. Dr. Alan Gardiner, however, tells me that ancient Egyptian literature contains repeated references to the process of anointing the body with "oil of cedar,"¹⁰ and great stress is laid upon this procedure as an essential element of the technique of embalming.¹¹

Thus in the time of the decadence of the New Empire an Egyptian writer laments the loosening of Egypt's hold on the Lebanons, because if no "oil of cedar" were obtainable it might become impossible any longer to embalm the dead.

Diodorus Siculus, writing many centuries later, says the body was "anointed with oil of cedar and other things for thirty days, and afterwards with myrrh, cinnamon, and other such like matters" (Pettigrew, 56, p. 62). Thus there can be little doubt that it was an essential part of the Ancient Egyptian technique to anoint the body with oil.

Pettigrew (56, p. 62, and also p. 242) adduces cogent reasons in proof of the fact that the Egyptians (and in modern times the Capuchins, at Palermo) made use of heat to desiccate the body, probably in a stove.

It is quite clear, therefore, that the Ancient Egyptians

¹⁰ Sir William Thiselton Dyer informs me that in all probability it was not *cedar* but *juniper* that was obtained by the Ancient Egyptians from Syria [and used for embalming]. The material to which reference is made here would probably be identical with the modern 'huile de cade,' and be obtained from *juniperus excelsa*.

I retain the term "oil of cedar" to facilitate the bibliographical references, as all the archæologists and historians invariably use this expression.

¹¹ Since this memoir has been printed Dr. Alan Gardiner has published a most luminous and important account of "The Tomb of Amenemhêt" (N. de Garis Davies and Alan Gardiner, 1915), which throws a flood of light upon Egyptian ideas concerning the matters discussed in this communication.

realised the importance of desiccation as an essential element in the preservation of the body. Moreover, they were familiar with a number of different means of ensuring this end:—(1) by burial in dry sand; (2) by exposure to the sun's rays; (3) by removing all the softer and more putrescible parts of the body; (4) possibly by massaging and squeezing out the juices from the body; (5) by the free use of alcohol (palm wine) and large quantities of powdered wood; and (6) by the aid of fire.

Dr. Alan Gardiner tells me that the most ancient Egyptian writings, such, for example, as the Pyramid texts, afford positive evidence that the Egyptians recognised the fact of the desiccation of the body in the process of embalming, for their scribes tell us, in the most definite manner, that the aim of the ceremony of offering libations was magically to restore to the body (as represented by the statue above ground) the fluids it had lost during embalming (Blackman, 5).

If then the Egyptians of the Pyramid Age recognised the importance of restoring the fluids to reanimate the mummy or its statue, it is quite clear they must have appreciated the physical fact that their process of preservation was largely a matter of desiccation.

It is a point of some interest and importance to note in this connection that the essential processes of mummification—(1) salting, (2) evisceration, (3) drying, and (4) smoking (or even cooking)—are identical with those adopted for the preservation of meat, and (5) the use of honey is analogous to the means taken to preserve fruit. In fact, the term used by Herodotus for the first stage of the Egyptian process of mummification is the term used for salting fish. It would be instructive to enquire in what measure these two needs of primitive man in North-East Africa mutually influenced one another, and led to an

acquisition of knowledge useful to them for the preservation both of their food and their dead relatives!

To the constituent elements of the "heliolithic" culture may now be added the practices of anointing with oil or unguents, the burning of incense and the offering of libations, all derived from the ritual of embalming.

In considering the southern extension of Egyptian influence it must be remembered that as early "as 2600 B.C. the Egyptian had already begun the exploitation of the Upper Nile and had been led in military force as far as the present Province of Dongola" (62, p. 23). For several centuries Nubia and the Soudan were left very much to themselves. Then during the time of the Middle Kingdom Egypt once more exerted a powerful influence to the South. At the close of that period Egypt was overrun by the Hyksos.

At Kerma, near the Third Cataract, Reisner has recently unearthed a cemetery which he refers to the Hyksos Period (62, p. 23). "The burial customs are revolting in their barbarity. On a carved bed in the middle of a big circular pit the chief personage lies on his right side with his head east. Under his head is a wooden pillow: between his legs a sword or dagger. Around the bed lie a varying number of bodies, male and female, all contracted on the right side, head east. Among them are the pots and pans, the cosmetic jars, the stools, and other objects. Over the whole burial is spread a great ox-hide. It is clear they were all buried at once. The men and women round about must have been sacrificed so that their spirits might accompany the chief to the other world. . . . I could not escape the belief that they had been buried alive" (62). These funerary practices supply a most important link in the chain which I am endeavouring to forge. I would especially call

attention (1) to the fact of the sacrifice of the chief's (? wives and) servants and (2) to the burial of the chief himself on a bed.

We know that the Egyptian practice of mummification spread south into Nubia (39) and the Soudan.

According to Herodotus the ancient Macrobioi preserved the bodies of their dead by drying: then they covered them with plaster, painted them to look like living men, and set them up in their houses for a year. For a fuller account of this practice and much more instructive information for comparison see Ridgeway's "Early Age of Greece," Vol. I., p. 483 *et seq.*

Numerous references in the classical writers lead us to believe that a similar custom of keeping the mummy in the house of the relatives for a longer or shorter period may have been in vogue in Egypt. Throughout the widespread area in which mummification was practised—from Africa to America—a precisely similar practice is found among many peoples.

The custom of covering the mummies with plaster¹² is an interesting survival of the practice described by Junker in Egypt (*vide supra*), which seems to supply the explanation of the curious measures adopted for modelling the face in Melanesia.

Even at the present day, centuries after the art of the embalmer disappeared from Egypt, mummification is being attempted by certain people dwelling in the neighbourhood of the head-waters of the Nile.

In his article in Hastings' Dictionary (32, p. 418) Hartland states that the practice of mummification is

¹² Mr. Crooke has called my attention to a similar practice in India. Leith (Journ. Anthr. Soc. of Bombay, Vol. I., 1886, pp. 39 and 40) stated that the *Kāśī Khanda* contained an account of a Brāhman who preserved his mother's corpse. After having it preserved and wrapped he "coated the whole with pure clay and finally deposited the corpse in a copper coffin."

found "more or less throughout the west of Africa : among the Niamniam of the Upper Nile basin the bodies of chiefs, and among the Baganda the kings, are preserved, and the custom is found also among the Warundi in German East Africa (Frobenius); and in British Central Africa the corpse is rubbed with boiled maize (Werner)."

Roscoe (72, p. 105), in his book on the Baganda, describes the process of embalming the king's body. As in Egypt, the body was disembowelled; and the bowels were washed in beer, just as the Egyptians, according to Herodotus and Diodorus, are said to have done with palm-wine. The viscera were spread out in the sun to dry and were then returned to the body, as was done in Egypt at the time of the XXIst Dynasty. The body was then dried and washed with beer.

So far as we are aware, the Egyptians never sacrificed any human beings at their funerals, although they often placed in the *serdab* of the *mastaba* statues of the deceased's wife, family and servants, to ensure him their presence and the comforts of a home in his new form of existence.

In the quotations from Reisner's report, it has just been seen that he found some burials made about 1800 B.C., in which servants appear to have been sacrificed.

In the case of the Baganda, Roscoe describes the killing of the king's wives and attendants at his funeral.

Roscoe further describes (in his book) the body of the chief as being laid on a bed or framework of plantain trees (p. 117).

At the end of five months the head was removed from the mummy and the jaw-bone was removed, cleaned, and then buried, and a large conical thatched temple was built over the jaw. [In the islands of the Torres Straits the same curious custom of rescuing the head after about

six months is also found ; but it was the tongue and not the jaw which received special attention (25 and 27)].

In Egypt, where the practice of mummification was most successful, special treatment of the head was not necessary, except occasionally in Ptolemaic times (39), when carelessness on the part of the embalmer led to disastrous results and it became necessary to "fake" a body for attachment to the separated head. But as the Baganda were unable to make a mummy which would last, they adopted these special measures with regard to the skull. Originally special importance was attached to the head, primarily (*vide supra*) as a means of identifying the deceased. But when the practice of preservation spread to uncultured people, whose efforts at embalming were ineffectual, the idea was transferred to the skull, the reason for the special treatment of the head probably being forgotten. Why such peculiar honour should be devoted to the jaw can only be surmised from our knowledge of the belief that the deceased was supposed to be able to talk and communicate with the living (21).

In his article in the *Journal of the Anthropological Institute* (72, p. 44) Roscoe give some further particulars. Four men and four women were clubbed to death at the funeral ceremony of the king.

The body was wrapped in strips of bark cloth and each finger and toe was wrapped separately.

In *L'Anthropologie* (T. 21, 1910, p. 53) Poutrin says of the burial customs of the M'Baka people of French Congo "le corps, préalablement embaumé avec des herbes sécher et de la cendre est couché sur un lit."

Weeks (104, pp. 450 and 451) gives an account of the burial customs of the Bangala of the Upper Congo. "They took out the entrails and buried them, placed the corpse on a frame, lit a fire under it, and thoroughly

smoke-dried it." "The dried body was tied in a mat, put in a roughly made hut." "Coffins were often made out of old canoes." "Poorer folk were rubbed with oil and red camwood powder, bound round with cloth and tied up in a mat."

One of the most remarkable instances of the survival of burial practices strangely reminiscent of those of ancient Egypt has been described by Mr. Amaury Talbot (99). Among the Ibibio people living in the extreme south-west corner of Nigeria, bordering on the Gulf of Guinea, he found that both the Ibibios and a neighbouring tribe, the Ibos, had burial rites which "recall those of ancient Egypt." For instance, "among Ibos embalming is still practised." Two methods of mummification, in which the evisceration of the corpse takes place, are practised.

For the grave "a wide-mouthed pit" was dug and "from the bottom of this an underground passage, sometimes thirty feet long, led into a square chamber with no other outlet. In this the dead body was laid, and, after the bearers had returned to the light of day, stones were set over the pit mouth and earth strewn over all." Further, in the case of the Ibibios, "in some prominent spot near the town arbour-like erections are raised as memorials, and furnished with the favourite property of the dead man. At the back or side of these is placed what we always called a little 'Ka' house, with window or door into the central chamber, provided, as in ancient Egypt, for the abode of the dead man's Ka or double. Figures of the Chief, with favourite wives and slaves, may also be seen—counterparts of the Ushabtiu."

From the photographs illustrating Mr. Talbot's article many other remarkable points of resemblance to ancient Egyptian practices are to be noted.

The snake and the sun constitute the obtrusive features of the crude design painted in the funeral shrine. The fact that so many features of the Egyptian burial practices should have been retained (and in association with many other elements of the "heliolithic" culture) in this distant spot, on the other side of the continent, raises the question whether or not its proximity to the Atlantic littoral may not be a contributory factor in the survival. They may have been spared by the remoteness of the retreat and the relative freedom from disturbance, to which nearer localities in the heart of the continent may have been subjected. But, on the other hand, there is the possibility that the spread of culture around the coast may have brought these Egyptian practices to Old Calabar. In the next few pages it will be seen that such a possibility is not so unlikely as it may appear at first sight.

But the fact that it was the custom among the Ibibio to bury the wives of the king with his mummy suggests a truly African, as distinct from purely Egyptian, influence, and makes it probable that the custom spread across the continent. This view is further supported by the traditions of the people themselves, no less than by the physical features of their crania (see *Report British Association*, 1912, p. 613).

As the people of the Ivory Coast (*vide infra*) practice a method of embalming which is clearly Egyptian and untainted by these African influences, it is clear that the two streams of Nilotic culture, one across the continent *viâ* Kordofan and Lake Chad and the other around the coasts of the Mediterranean and Atlantic, after reaching the West Coast must have met somewhere between the mouth of the Niger and the Ivory Coast.

[Since writing the above paragraphs, in which infer-

ences as to racial movements across Africa were based solely upon the distribution and methods of mummification, I have become acquainted with remarkable confirmation of these views from two different sources. Frobenius, in his book "The Voice of Africa," 1913 (see especially the map on p. 449, Vol. II.), makes an identical delimitation of the two spheres of influence from the east, trans- and circum- African (*i.e.*, *via* the Mediterranean) respectively.

Sir Harry Johnston ("A Survey of the Ethnography of Africa," *Journ. Roy. Anthr. Inst.*, 1913, p. 384) supplies even more precise and definite confirmation of the route taken by the Egyptian culture-migration across Kordofan to Lake Chad, thence to the Niger basin and "all parts of West Africa."

He adds further (pp. 412 and 413):—"Stone worship and the use of stone in building and sepulture extend from North Africa southwards across the desert region to Senegambia (sporadically) and the northern parts of the Sudan, and to Somaliland. The superstitious use of stone in connection with religion, burial and after-death memorial, reappears again in Yoruba, in the North-West Cameroons and adjoining Calabar region (Ekir-land)."]

For the purpose of embalming the bodies of their dead "the Baoule of the Ivory Coast remove the intestines, wash them with palm wine or European alcohol, introduce alcohol and salt into the body cavity, afterwards replacing the intestines and stitching up the opening." (Clozel and Villamur, quoted by Hartland, 32, p. 418.)

Scattered around the western shores of the African continent there are numerous ethnological features to suggest that it has been subjected to the influence of the megalithic culture spreading from the Mediterranean. But there is no spot in which this influence and its

Egyptian derivation is more definitely and surely demonstrated than in the Canary Islands.

For the art of embalming was practised there in the truly Egyptian fashion ; and it became a matter of some interest to discover whether or not the Nigerian customs were influenced in any way by the Guanche practices.

There can be little doubt that the practices on the Ivory Coast, to which reference has just been made, were either inspired by the Guanches or by the same influence which started embalming in the Canary Islands.

The information we possess in reference to the Canary Islands was collected by Bory de Saint Vincent (" *Les Îles Fortunées*," 1811, p. 54) and has been summarized by many writers, especially Pettigrew, Haigh and Reutter.

From Miss Haigh's account (26, p. 112) I make the following extracts :—

" When any person died they preserved the body in this manner ; first, they carried it to a cave and stretched it on a flat stone, opened it and took out the bowels ; then twice a day they washed the porous parts of the body with salt and water ; afterwards they anointed it with a composition of sheep's butter mixed with a powder made from the dust of decayed pine trees, and a sort of brushwood called " *Bressos*," together with powdered pumice stone, and then dried it in the sun for fifteen days

" When the body was thoroughly dried, and had become very light, it was wrapped in sheep skins or goat skins, girded tight with long leather thongs, and carried to one of the sepulchral grottoes, usually situated in the most inaccessible parts of the island.

" The bodies were either upright against the sides of the cavern, or side by side upon a kind of scaffolding

made of branches of juniper, mocan, or other incorruptible wood.

“The knives for opening the body were made of sharp pieces of obsidian.

“In the grotto of Tacoronté was the mummy of an old woman dried in the sitting posture like that of the Peruvian corpses.”

The mummies were wrapped in reddish goat skin, just as the shroud of Egyptian mummies was often of red linen.

From the same article, in which, as the above quotation states, the body was placed upon a stone for the purpose of the embalmer's operations, I should like to call attention to the following statement of a curious custom which is found in the most diverse parts of the world, in most cases in association with the practice of mummification.

Tradition says that at his installation the new Mencey (or chief of a principality) is required to seat himself on a stone, cut in the form of a chair and covered with skins: one of his nearest relatives presents him with a sacred relic—the bone of the right arm of the chief of the reigning family (p. 107). I have already (*supra*) indicated the significance of this characteristic feature of the “heliolithic” culture.

Reutter (63) gives some additional information in reference to Guanache embalming. The incision was made in the lower part of the abdomen (in the flank). After the body had been treated with a saturated salt solution, the viscera were returned to the body. The orifices of the nose, mouth and eyes were “stopped with bitumen as was the Egyptian practice.” After packing the cavities of the body with aromatic plants the body was exposed either to the sun, or in a stove, to desiccate it.

During this operation, other embalmers repeatedly smeared the body with a kind of ointment, prepared by mixing certain fats, with powdered odoriferous plants, resin, pumice stone and absorbent substances (p. 139).

As in Egypt, according to Herodotus and Diodorus,—and my own observations have verified their account, at any rate so far as its chief feature is concerned—there was another method of embalming in which no abdominal incision was made, unless it was *per rectum*.

When this cheaper method was employed the corpse was dried in the sun and some corrosive liquid, called “cedria” in the case of the Egyptians, but in that of the Guanches supposed by Dr. Parcelly to be Euphorbia juice, was injected for the purpose of dissolving the intestines and thus facilitating the process of preservation by removing the chief seat of decomposition.

[It is important to recall the fact, to which I have already referred in this account, that in the islands of the Torres Straits also the same two alternative methods of evisceration, either through a flank incision or *per rectum* were in use.]

Most mummies, wrapped in goat skins, were buried in caves. But those of kings and princes were placed in coffins cut out of a solid log, and buried (head north) in the open, a monument of pyramidal form being erected above them.

It is important to bear in mind that both in East and West Africa and in the Canary Islands the technical procedures in the practice of mummification are those which were not adopted in Egypt until the time of the XXIst Dynasty. I have already called attention to this fact in my references to the Torres Straits mummies (*vide supra*), and to the inference that these extensive migrations of Egyptian influence could not have begun before the ninth century B.C.

(For more complete bibliographical references, see Pettigrew, 56, p. 233.)

The large series of identical procedures makes it absolutely certain that the method of embalming practised in the Canary Islands was derived from Egypt, and not earlier than 900 B.C.

Reutter states (63, p. 137) that "the Carthaginians, as the result of long-continued commercial intercourse with Egypt, assimilated its civilization even to the extent of worshipping certain of the Egyptian gods and of accepting many of her ideas and beliefs as to a future life."

"These reasons impelled them to practise the art of embalming and to represent the features of the dead upon their sarcophagi to enable the soul to refind its double."

"Their burial chambers, for the most part not built up, but carved out of the rock, communicated with the exterior by a staircase. Above them were built mastabas or monuments to be utilised, as amongst the Egyptians, as offering-places" (p. 138).

"Even the inscriptions in the mortuary chambers were written in hieroglyphics, and their sarcophagi contained scarabs inscribed with invocations to the Egyptian gods, Ptah, Bes and Ra, &c."

This reference is sufficient to indicate how the later (certainly not earlier than 900 B.C. and probably some centuries later) Egyptian practices spread around the Mediterranean.

I do not propose (in the present communication) to discuss the influence and the manner of spread of the practice of mummification in Europe. Reutter gives certain information in reference to this subject. It will suffice to say that there is no evidence to show that mummification was widely adopted until comparatively

late times (New Empire and later) in the Mediterranean area, although certain effects of the Egyptian practice, such for example as "extended burial," spread abroad many centuries earlier, appearing in most regions during the Eneolithic phase.

The procedures revealed in the Canary Islands bear no trace of the influence of Negro Africa to which I have called attention (*supra*) in the Soudan, Uganda, the Congo and the Niger. The details of the technique suggests the method employed in the XXIst Dynasty; and other features seem to point to the conclusion that the practice must have reached the Canary Islands from the Western Mediterranean through the Straits of Gibraltar, not improbably through Phœnician channels.

[For a full critical discussion of all the literature relating to Egyptian influence in West Africa see Dahse, "Ein zweites Goldland Salomos," *Zeitsch. f. Ethn.*, 1911, p. 1. The mass of evidence collected in this memoir is entirely corroborative of the conclusions at which I have arrived from the study of mummification.]

With reference to Babylonia Langdon (32) states:—"Traces of embalming have not been found, but Herodotus says that the Babylonians preserved in honey. But a text has been discovered which mentions embalming with cedar oil (cited by Meissner, *Weiner Zeitsch. f. Kunde des Morgenlandes*, xii, 1898, p. 61). At any rate embalming is not characteristic of Babylonian burials and the custom may be due to Egyptian influence."

There can, I think, be no doubt whatever as to the Egyptian origin of these instances of embalming in Babylonia. The mere fact of its sporadic occurrence in a country of which it is not characteristic clearly points to this conclusion, which is confirmed by the emphasis laid upon the use of oil of cedar—a definite indication of

the Egyptian practice. The reference of Herodotus to the use of honey in Babylonia is also of peculiar interest, for it provides us with a connecting link between the Mediterranean area and India and Burma.

The extensive use of honey for the preservation of the body among the Greeks, Romans, Jews, and possibly also the Egyptians, is indicated by the frequent references to the practice in the classics, which have been summarised, with numerous quotations, by Pettigrew (56, pp. 85—87).

The employment of honey suggests the spread of Egyptian influence to Babylonia *viâ* the Mediterranean and Syria, seeing that, so far as is known, such a method was used only on the Mediterranean littoral of Egypt, in Phœnicia and the Ægean.

Concerning the use of wax in the process of embalming, of which ancient Egyptian mummies, especially of the new Empire (86), afford numerous instances, Pettigrew (p. 87) remarks:—"The body of King Agesilaus was enveloped in wax and thus conveyed to Lacedæmon. This is confirmed by Cornelius Nepos, and also by Plutarch, who ascribe the adoption of wax to the want of honey for this purpose. Cicero reports the use of it by the Persians."

In his account of the methods employed by the Scythians (living north of Thrace) for mummifying their kings, Herodotus tells us that the body was coated with wax, the abdomen opened, cleaned out and then filled with pounded stems, with perfumes, aniseed and wild celery seed and then stitched up. The important bearing of the practices described in the Black Sea littoral upon Indian and Burmese customs (*vide infra*) I must reserve for discussion at some later time.

It will be seen in the subsequent account that honey was in use for embalming in modern times in Burma.

In an article on Persian burial customs (32, p. 505) Dr. Louis H. Gray says: "Unfortunately our sole information on this subject [Ancient Persian rites] must thus far be gleaned from the meagre statements of the classics. If we may judge from the tombs of the Achæmenians, their bodies were not exposed as Zoroastrianism dictated; but it is by no means impossible that they were coated with wax, or even, as Jackson¹³ also suggests ("Persia, Past and Present," p. 235), 'perhaps embalmed after the manner of the Egyptians.'"

In later times the Persians seem to have been influenced by the practices in vogue in Early Christian times in Egypt, before the coming of Islâm. Thus in Moll's History (46, p. 545), the statement is made in reference to the Moslem burial customs in Persia; "if it [the corpse] is to be buried a great way off, it is put into a wooden coffin filled up with salt, lime and perfumes to preserve it; for they embalm their dead bodies no otherwise in Persia, nor do they ever embowel them, as with us." That this is merely a degraded form of the Egyptian embalmer's practice is shown by the fact that it is identical with the method used by the Copts in Egypt until the seventh, or perhaps even as late as the ninth century A.D., and in their case we know that it is a development from, or degradation of, the ancient practice.

¹³ Jackson refers the suggestion to Curzon's "Persia and the Persian Question," 1892, where I find (Vol. II., pp. 74, 79, 80, 146, 178 and 192) most conclusive evidence in proof of the fact that the body of Cyrus was mummified and all the Egyptian rites were observed (see especially Mr. Cecil Smith's note on p. 80). In Persia, under Darius (p. 182), the Egyptian methods of tomb-construction were closely copied, not only in their general plan, but in minute details of their decoration (see p. 178)—also the bas-relief of Cyrus wearing the Egyptian crown (p. 74). Cambyses even introduced Egyptian workmen to carry out such work (p. 192).

There are reasons for believing that India also was in turn influenced by this direct transmission of Egyptian practices to Persia, but only after (perhaps more than a century after) the Ethiopian modification of Egyptian embalming had been adopted there.

This method seems also to have spread to India: for Mr. Crooke tells me that even at the present day several of the ascetic orders bury their dead in salt.

In Moll's book the following curious statement also occurs, p. 474:—"Mummy, which is human flesh embalm'd that has lain in dry earth several ages, and become hard as horn, is frequently found in the sands of Chorassan, or the ancient Bactria, and some of the bodies are so little alter'd, 'tis said, that the features may be plainly distinguish'd."

In studying the easterly migration of the custom of mummification it is quite certain that the main stream of the wanderers who carried the knowledge to the east must have set out from the East African coast, because a whole series of modifications of the Egyptian method which were introduced in the Soudan and further south are also found in Indonesia, Polynesia and America. A curious feature of Egyptian embalming in the XIXth and especially the XXIst Dynasties (78 and 86) was the use of butter for packing the mummy. Among the Baganda, according to Roscoe, special importance came to be attached to this practice. Mr. Crooke has given me references from Indian literature (see especially *Journ. Anthr. Soc. Bombay*, Vol. I., 1886, p. 39) to bodies being "skilfully embalmed with heavenly drugs and *ghee*" [clarified butter].

The ancient Aryans used to disembowel the corpse and fill the cavity with *ghee* (Mitra, "Indo-Aryans," London, 1881, Vol. I., p. 135), as was done in the case of the mummy of the famous Pharaoh Menepthah (86).

The peculiarly Mediterranean modifications also spread east and it seems most likely that in this case the route from Syria down the Euphrates to the Persian Gulf was taken.

[Since this has been in print further investigation has

elucidated with remarkable precision the ways and means of, as well as the impelling motives for, the great migration to the East. This calls for some modification of the foregoing (as well as many of the subsequent) paragraphs. It has been seen that the great wave of culture carried east and west from Egypt the distinctive method of embalming that came into full use somewhere about 900 B.C. ; hence it is probable the eighth century B.C. witnessed the commencement of the series of expeditions, which probably extended over many centuries. It can be no mere chance that the period indicated coincides with the time when the Phœnicians were embarking upon maritime enterprises on a much greater and more daring scale than the world had known until then, in the Mediterranean and Atlantic, in the Red Sea and beyond. In the course of their trading expeditions to the Bab-el-Mandeb these Levantine mariners brought to that region a fuller knowledge of the customs and practices of Egypt and of the whole Phœnician world in the Mediterranean. It was probably in this way and not by the Euphrates route that the culture of the Levant reached the Persian Gulf and India.

The easterly migration of culture which set out from the region of the Bab-el-Mandeb conveyed not only the Ethiopian modifications of Egyptian practices, but also the Egyptian and Mediterranean contributions which the Phœnicians had brought to Ethiopia. On some future occasion I shall discuss the important part played by the Phœnicians in these expeditions to the Far East.]

It is unfortunate that practically nothing is known of the practice of mummification on the Southern coast of Arabia. Bent tells us that the Southern Arabians preserved their dead. Moreover, as the Egyptians obtained from Sabæa much of the materials used for

embalming, it is not unlikely that the Arabs may also have learned the use of these preservatives.

In support of this suggestion I might refer to the evidence from Madagascar. It is well known that this island was colonised in ancient times by people from the neighbourhood of the Bab-el-Mandeb, probably Galla-people from the Somali coast as well as Sabæans from the Arabian coast, possibly ferried along the African shore by expert mariners from Oman and the Persian Gulf, either the Phœnicians themselves or their kinsmen. A more numerous element came from the distant Malay Archipelago. Either or both of these racial elements may have introduced the practice of mummification into Madagascar.

In his "History on Madagascar" (1838, Vol. I, p. 243) Ellis says there "was no regular embalming," but the "body was preserved for a time by the use of large quantities of gum benzoin, or other powdered aromatic gums." This method is strongly suggestive of South Arabian influence.

Hartland says "the Betsileo [and other Madagascar tribes] dry the corpse in the air, the fluids being assisted to escape" (32, p. 418).

Grandidier, however, gives us more precise information on this subject ("La Mort et les Funerailles à Madagascar," *L'Anthropologie*, T. 23, 1912, p. 329). According to him the Betsileo open the body of the dead and remove all the viscera, which they throw into a lake: among the Merina the entrails are removed only in the cases of their sovereigns or members of the royal family.

The practice of mummification amongst the Betsileo is of peculiar interest because the embalmed bodies are buried in stone tombs obviously inspired by Egyptian

models. The subterranean megalithic burial chamber in association with an oblong *mastaba*-like superstructure at once recalls the distinctive features of the Egyptian tomb. But there is a curious feature suggestive of Babylonian influence, namely, the situation of the temple of offerings on the top of the *mastaba*. In some respects this type of grave recalls those found in the Bahrein Islands by Bent (4), which he compares with the Early Phœnician tombs at Arvad (55). There can be no question that the latter were copied from Theban tombs of the New Empire (*vide supra*).

This seems to point quite clearly to the fact that the Betsileo burial practices were inspired by Egyptian models, possibly modified by Southern Arabian influences.

In Hall's "Great Zimbabwe" (1905, pp. 94 and 95), it is stated that "the Baduma, who live in Gutu's country, and also the Barotse, still embalm, or, rather, dry the bodies of their chiefs, and also the dead of certain families, though generally the bodies are buried lengthways on their right side, facing the sun. "The body is placed in the hut on a bier made of poles near a large fire, and continually turned until the body is dry. Then it is wrapped up in a blanket and hung from the roof" [as is done in the Doré Bay region in New Guinea].

There has been considerable controversy as to the origin of the vast stone monuments in this region. The writer from whom I have just quoted, with many others, believed the Zimbabwe ruins to be the work of Early Sabæan or Phœnician immigrants, who were attracted by the Rhodesian gold-fields. Randall-MacIver believed that he found Chinese and Persian relics (no earlier than the 14th or at earliest 13th century) under the foundations; and recklessly jumped to the conclusion that the local Negroes had conceived and built these vast monu-

ments! The idea of any savage people, and especially Negroes, planning such structures and undertaking the enormous labour of their construction is surely too ludicrous to be considered seriously. Even if these monuments were built no earlier than five or six centuries ago, that does not invalidate the hypothesis that they were inspired by the models of some old civilization. Is it necessary to expound the whole theory of survivals to make this point clear? The whole of this memoir is concerned with the persistence in outlying corners of the world of strange practices whose inventors passed away twenty-eight centuries and more ago, and whose country has forgotten them and their works for more than a thousand years. [My friend, W. J. Perry, is collecting other evidence which proves quite definitely that the Zimbabwe culture was "heliolithic."]

In Moll's History (46) the following passage occurs in an account of the customs of Ceylon, p. 430, "when a person of condition dies his corps is laid out and wash'd, and being cover'd with a linnen-cloath, is carried out upon a bier to some high place and burnt: but if he was an officer who belong'd to the court, the corps is not burnt till the king gives orders for it, which is sometimes a great while after. In this case his friends hollow the body of a tree, and having bowell'd and embalm'd the corps, they put it in, filling the hollow up with pepper, and having made it as close as possible, they bury the corpse in some room of the house till the king orders it to be burnt."

"As for the poorer people, they usually wrap them up in mats and bury them."

This traveller's tale would not call for serious attention if it were not confirmed by modern accounts of an analogous practice in Burma and the neighbourhood.

In his "Himalayan Journal" Sir Joseph Hooker described how the Khasias temporarily embalm their dead in honey before cremating them.

Pettigrew (56, p. 245) quotes Captain Coke's account of the embalming of a Burman priest. The body, as witnessed by him, was lying exposed to public view upon a stage constructed of bamboos. This is the bier which is so invariably associated with mummification.

"The entrails of the deceased (who had been dead upwards of a month) had been taken out a few hours after death by means of an incision in the stomach, and the vacuum being filled with honey and spices the opening was sewed up. The whole body was then covered over with a slight coating of resinous substance called *dhamma*, and wax, to preserve it from the air, after which it was richly overlaid with gold leaf, thus giving the body the appearance of one of the finely moulded images so common in the temples of the worshippers of BOODH."

Then it was cremated.

This is a curious instance of the blending of the custom of mummification with the later practice of cremation, which was inspired by entirely different ideals. Throughout the whole area in which Egyptian methods of embalming were adopted there are found numerous instances of such syncretism with a variety of burial customs.

"Another method which I have known to be practised, but not as common as the one above detailed, of embalming bodies in the Burman country, is by forcing two hollow bamboos through the soles of the feet, up the legs and into the body of the deceased; then by dint of pressing and squeezing the fluid is carried off through the bamboos into the ground."

This practice is an important link between the Egyptian and the Indonesian methods.

In his article on Thibetan burial customs (32, p. 511), Waddell informs us that preservation of the entire body by embalming seems to be restricted to the sovereign Grand Lamas of Lhāsa and Tāshilhumpo. The body is embalmed by salting, and, clad in the robes of the deceased and surrounded by his personal implements of worship, is placed, in the attitude of a seated Buddha, within a gilded copper sarcophagus in one of the rooms of the palace: it is then worshipped as a divinity."

There are many points of interest in this practice, which, considered in conjunction with the methods practised in Burma, Ceylon and Persia just mentioned, clearly indicate not only the sources and the routes taken by this knowledge of embalming in its spread from Egypt, but also how the burial rites of a variety of peoples can become intimately blended and intermingled one with another.

In Captain T. H. Lewins' book on "The Wild Tribes of South-Eastern India" (London, 1870, p. 274) I find the following statement:—"Among the Dhun and Khorn clans the body is placed in a coffin made of a hollow tree trunk, with holes in the bottom. This is placed on a lofty platform and left to dry in the sun. The dried body is afterwards rammed into an earthen vase and buried; the head is cut off and preserved. Another clan sheathe their dead in pith; the corpse is then placed on a platform, under which a slow fire is kept up until the body is dried. The corpse is then kept for six months . . . it is then buried. The Howlong clan hang the body up to the house-beams for seven days, during which time the dead man's wife has to sit underneath spinning."

These interesting records are of considerable value in establishing connexions between East Africa and regions further east, which will be discussed in the following pages.

[In my search for information concerning the practice of embalming in India, where by inference I was convinced it must have had some vogue in ancient times, I completely overlooked the important memoir by Mr. W. Crooke on "Primitive Rites of Disposal of the Dead, with Special Reference to India" (*Journ. Anthropol. Inst.*, Vol. XXIX., 1899, p. 272). Since the rest of this article has been in print Mr. Crooke has kindly called my attention to his memoir and given me a lot of other valuable information. Fortunately all this evidence supports and substantiates the opinions I had previously arrived at inductively. For it provides a complete series of connecting links between the western and eastern portions of the chain I am reconstructing. It is too bulky to insert here and too important merely to summarise, so that I must postpone fuller discussion of this Indian evidence until some future time.]

If it is admitted that the custom of mummification as it is practised, for example, in the islands of the Torres Straits was derived from Egypt, however remotely and indirectly, it is clear that, as the technique includes a number of curious features which were not introduced in Egypt before the XVIIIth, XXth and XXIst Dynasties (respectively in the case of different procedures), the migration of people carrying the methods east could not have left Egypt before the time of the XXIst Dynasty, say 900 B.C. as the earliest possible date. At this time Egypt was in very close relationship with the Soudan and Western Asia; and it is obvious that the Egyptian practices may have reached the Persian Gulf by three routes:—(1) *via* the Soudan, the headwaters of the Nile and the Somali Coast, (2) by the Red Sea route, and (3) from the Phœnician Coast down the Euphrates. No doubt all three routes served as avenues for communi-

cation and for the transmission of cultural influences ; and it is not essential for our immediate purposes to enquire which channel served to transmit each element of Egyptian culture that made its influence felt in the neighbourhood of the Persian Gulf at this period. For it was a period of active maritime enterprise, especially on the part of the Phœnicians, both in the Mediterranean and the Southern Seas, and a time when the fluctuating political fortunes of Egypt, Western Asia and the Soudan produced a more intimate intermingling of the peoples, so that they mutually influenced one another most profoundly.

It is important to remember that many of the features of the embalmer's art as it is practiced in the far East are modifications of the Egyptian method which were first introduced in the region of the Upper Nile, so that the East African Coast must have been the point of departure for such methods. Other features, not only of the method of embalming, but also of the associated megalithic architecture, were equally distinctive of the Phœnician region and may have been transmitted by the Euphrates.¹⁴ Other features again were distinctively Babylonian. Of the former, the African influence, I might refer to the use of the frame-like support for the mummy, the custom of removing the head some months after burial, and the sacrifice of wives and servants. As to the Phœnician and Babylonian influences, the use of honey might be cited, and the emphasis laid upon "cedar" wood and "cedar" oil in mummification ; and the Phœnician adaptation of the New Empire type of Theban tomb seen at Arvad and the analogous

¹⁴ See, however, p. 69. At some future time I shall explain what an important link is provided by the ancient culture of the Black Sea littoral between Egypt and the civilizations of the Western Mediterranean on the one hand and India on the other.

sepulchres found in the Bahrein Islands (4). The Betsileo tombs in Madagascar probably represent the same type transferred *viâ* Sabæa down the East African coast.

As to the means by which the customs of the dwellers around the Persian Gulf were communicated to the peoples of India and Ceylon there is a considerable mass of evidence. The fact that mummification, the building of megalithic monuments of the recognised Mediterranean types, sun- and serpent-worship and all the other impedimenta of the "heliolithic" culture made their appearance in India in pre-Aryan times affords positive evidence of the reality of the intercourse. I have already referred to the adoption in India of the curiously eccentric method of steering river-boats found in Middle Kingdom Egyptian tombs; and the custom of representing eyes on the prow of the boat are further illustrations of the spread of distinctive practices. According to Rhys Davids (14, p. 116) "it may now be accepted as a working hypothesis that sea-going merchants [mostly Dravidians, not Aryans], availing themselves of the monsoons, were in the habit, at the beginning of the seventh (and perhaps at the end of the eighth) century B.C., of trading from ports on the South-West of India to Babylon, then a great mercantile emporium." He adduces evidence which clearly demonstrates that the written scripts of India, Ceylon and Burma were in this way derived from "the pre-Semitic race now called Akkadians." "It seems almost impossible to avoid the conclusion that [the] curious buildings [at Anurādhapura in Ceylon] were not entirely without connection with the seven-storied Ziggurats which were so striking a feature among the buildings of Chaldæa. . . . it would seem that in this case also the Indians were borrowers of an idea" (p. 70). The more precise and definite influence of

Babylonian models further east removes any doubt as to the part it played. Crooke speaks of the Southern Dravidians as a maritime people, who placed in their burial mounds "bronze articles which were probably imported in the course of trade with Babylonia" (12, p. 29). "They were probably the builders of the remarkable series of rude stone monuments which crown the hills in the Nilgiri range and the plateau of the Deccan" (p. 28). The most ancient stone monuments in Southern India contain objects which go to prove that they were built at the earliest just before the introduction of iron-working. Thus, if the knowledge of iron-working came from Europe, these monuments could not have been built much before 800 B.C. As a matter of fact it is known that many of them cannot be older than 600 B.C. (Crooke, 13, p. 129). All of these facts agree in supporting the view that the influence of Egypt, which, so far as the matters under consideration are concerned, came into operation not earlier than the eighth century B.C., spread to India partly *viâ* Babylonia and partly by way of East Africa, somewhere between the close of the eighth and the commencement of the sixth century B.C.

The monuments to which I have just been referring were not, in my opinion, directly inspired by Egypt, but indirectly. The North Syrian and the adjoining territories adopted the Egyptian burial customs at an earlier period and the finished type of holed dolmen was probably developed and survived in that region long after its Egyptian prototype had become a thing of the past. The real types that have come down to our times are found in the Caucasus, between the Black Sea and the Caspian. The Indian dolmens were certainly imitations of these models. But in respect of other buildings the Indians directly adopted Babylonian and Egyptian types.

I have already referred to the former. Many of the Dravidian temples are so precisely modelled on the plan of the Theban temples of the New Empire that to question the source of the inspiration of the former is impossible.

“Fergusson first called attention to the striking similarity in general arrangement and conception between the great South Indian temples and those of ancient Egypt. . . . The gopurams or gate-towers, which in the later more ornate examples are decorated from the base to the summit with sculptures of the Hindu Pantheon, increase in size with the size of the walled quadrangles, the outer ones becoming imposing landmarks, which are visible for miles around, and are strikingly similar to the pylons of Egyptian temples” (Thurston, 101, pp. 158 and 161). Thus in the matter of its early buildings India has clearly been influenced by Egypt, Phœnicia and Chaldea; and this great cultural wave impinged upon the Indian peninsula not before the close of the eighth century B.C.

It is important also to remember that it reached India just (perhaps not more than a century) before another wave of a very different culture poured down from the north, and introduced, among other things, the practice of cremation.

For our immediate purpose this is unfortunate, because that practice is inspired by ideas utterly opposed to those underlying the custom of embalming, and naturally destroyed most, though by no means all, traces of the latter. That the practice of embalming did actually reach India from the west is known not merely because evidence of unmistakably Egyptian technique is found further east, but also because in India and Ceylon there are definite traces of the custom, to which reference has already been made in the foregoing pages. Cases

from Persia, Ceylon, India, Burma and Thibet were cited in proof of the survival of elements of the embalming process or ritual, even when the Brahmanical and Buddhist burial practices had been adopted.

From the foregoing account there can be no doubt that the people of India did at one time practice mummification, at any rate in the case of their chiefs. They also acquired a knowledge of the arts and crafts, as the result of the influence exerted by the rich stream of culture which brought the attainments of the great western civilizations to India before the Aryan immigration. The bringers of this new culture mingled their blood with the aboriginal pre-Dravidian population and the result was the Dravidians. It is not at all improbable that the resultant Dravidian civilization had reached a higher plane than that of the Aryas, who entered the country after them.

In Oldham's interesting and suggestive brochure (51, pp. 53—55), which, in spite of Crooke's drastic criticism, seems to me to be a valuable contribution to a knowledge of the questions under discussion, the following passages occur:—

“The Asuras, Dasyus, or Nagas, with whom the Aryas came into contact, on approaching the borders of India, were no savage aboriginal tribes, but a civilized people who had cities and castles. Some of these are said in the Veda to have been built of stone.

“It would seem, indeed, as if the Asuras had reached a higher degree of civilization than their Aryan rivals. Some of their cities were places of considerable importance. And, in addition to this, wealth and luxury, the use of magic, superior architectural skill, and ability to restore the dead to life, were ascribed to the Asuras by Brahmanical writers.”

The "ability to restore the dead to life" is probably a reference to the Egyptian ritual of "the opening of the mouth," which of course is an integral part of the funerary procedure incidental to the practice of mummification.

"The Nagas occupy a very prominent position in connection with Indian astronomy, and this is not likely to have been assigned to them, by their Brahmanical rivals, without good reason. Probably this and other branches of science were brought, by the Asuras, from their ancient home in the countries between the Kaspian and the Persian Gulf.

"The close relationship between the Indian and the Chaldean astronomical systems has been frequently noticed.

"The sun-worship of the Asuras; their holding sacred the Naga or hooded serpent, sometimes represented with many heads; their deification of kings and ancestors; their veneration of the cedar; their religious dances; their sacrificial rights; their communication with the deities through the medium of inspired prophets; their occasional tendency towards democratic institutions; their use of tribal emblems or totems—and many of their social customs; seem to connect them with that very early civilization—Turanian or otherwise—which we find amongst so many of the peoples of extreme antiquity. They had, in fact, much in common with the early inhabitants of Babylonia; and, perhaps, even more with those of Elam and the neighbouring countries.

"We shall see later that the Asuras and the Dravidians were, apparently, the same people."

"Not only were the Asuras or Nagas a civilized people, but they were a maritime power. Holding both banks of the great river Indus, they must have had access to the sea from a very early period. Their kinship, too,

with the serpent-worshipping people of ancient Media, and the neighbouring countries, which has already been referred to, must have led to a very early development of trade with the Persian Gulf.

“The Asuras were actively engaged in ‘The Churning of the Ocean’ (*Mahabharata, Adi, Astika*, p. xviii.), which is but an allegorical description of sea-borne commerce in its early days” (*op. cit.*, p. 58).

“In the *Mahabharata*, the ocean is described as the habitation of the Nagas and the residence of the Asuras; it is also said to be the refuge of the defeated Asuras (*Mahabharata, Adi, Astika*, p. xxii.). This was no doubt because marauding bands of this people retreated to their ships after an unsuccessful raid. Thus we find that on the death of Vrita, his followers took refuge in the sea (*Mahabharata, Vana, Tirthayatra*, p. ciii.). So also did the Asura Panchajana, who lived in Patala, when he was pursued by Krishna (*Vishnu Purana*, v., xxi., 526). And so did the Danavas when defeated by the Devas at the churning of the ocean (*Mahabharata, Adi, Astika*, p. xix.)”

“An ancient legend, given in the *Mahabharata*, relates how Kadru, mother of the serpents, compelled Garuda to convey her sons across the sea into a beautiful country in a distant region, which was inhabited by Nagas. After encountering a violent storm and great heat, the sons of Karur were landed in the country of Ramaniaka, on the Malabar coast.”

“This territory had been occupied previously by a fierce Asura named Lavana (*Mahabharata, Adi, Astika*, p. xxvii.). So there had been a still earlier colonization by the same race.”

“Naga chiefs are frequently mentioned as ruling countries in or under the sea” (p. 61).

“ The civilization of Burmah, and other Indo-Chinese countries, is ascribed by legend and by the native historians to invaders from India. And these are connected with the Naga People of Magadha, and of the north and west of India. The ancient navigators, too, who carried the Brahmanical and Buddhist religions, the worship of the Naga, and the Sanscrit or Pali language to Java, Sumatra, and even to distant Celebes, were Indian people. And they were, doubtless, descendants of those Asura dwellers in the ocean, which are mentioned in the *Mahabharata*, and have already been referred to ” (p. 166).

“ Another proof of the ancient connection of these islands with India is that the Javan era is the Saka-kala, which is so well known, and is still in use in parts of Western India and in the Himalaya. According to a Javan tradition an expedition from India, led by a son of the king of Kujrat (Gujrat), arrived on the west coast of the island about A.D. 603. A settlement was founded, and the town of Mendan Kamalan was built. Other Hindus followed, and a great trade was established with the ports of India and other countries (Raffles, *Hist. Java*, ii., 83). There is however no reason to suppose that this was the first arrival of Indian voyagers in the Archipelago.

“ Traditions still remain in Western India of expeditions to Java. A Guzerati proverb runs thus : ‘ He who goes to Java never comes back ; but if he does return, his descendants, for seven generations, live at ease ’ (*Bombay Gazetteer*, i., 402). The bards in Marwar have a legend that Bhoj raja, the great puar chief of Ujaini, in anger drove away his son Chandrabhan, who sailed to Java (*Ib.*, i., 448).

“ Evidence brought forward by Mr. Kennedy (*J. R. A. S.*, April, 1898) shows that a great sea-borne

trade was carried on from Indian ports by Dravidian merchants as early as the seventh century B.C. The beginnings of Dravidian navigation, however, were probably much earlier than this.

“We have seen that the sea-borne commerce of the Solar or Naga tribes of Western India had become important at a very early period. Of this the legend of ‘the churning of the ocean’ already referred to is an allegorical description, but we have no detailed account of ocean voyages until a much later period. Sakya Buddha himself, however, refers to such voyages. He says: ‘Long ago ocean going merchants were wont to plunge forth upon the sea, taking with them a shore-sighting bird. When the ship was out of sight of land they would set the shore-sighting bird free. And it would go to the east and to the south and to the west and to the north and to the intermediate points and rise aloft. If on the horizon it caught sight of land, thither it would go. But if not then it would come back to the ship again’ (Rhys Davids, *J. R. A. S.*, April, 1899, 432).

“It will be observed that this mode of finding the position of the ship at sea, which recalls the sending out of the birds from the Ark, is said to have been the custom ‘long ago.’ It would seem therefore, that in the fifth century B.C. other and probably more scientific methods were in use. It would also appear that the navigation of the ocean was even then an ancient institution.

“In the time of the Chinese Buddhist pilgrim Fah Hian (about 406 A.D.) there was a regular and evidently old-established trade between India and China and with the islands of the Archipelago.

“Fah Hian sailed from Tamalitti, or Tamralipti, at the mouth of the Ganges, in a great merchant ship, and in fourteen days reached Ceylon (Fo-Kwo-ki, *Beal*, i, lxxi,

lxxii.). From thence he sailed in a great ship which carried about two hundred men, and which was navigated by observing the sun, moon and stars. In this ship Fah Hian reached Ye-po-ti (probably Java) in which country heretics and Brahmans flourished, but the law of Buddha was not much known (*Ib.*, I, lxxx.). Here the pilgrim embarked for China on board another ship carrying two hundred men, amongst whom were Brahmans. These proposed to treat the sramana as Jonah was treated, and for the same reason, but some of those on board took his part. At length when their provisions were nearly exhausted, they reached China (*Ib.*, I, lxxxii.). All these ships appear to have been Indian and not Chinese.

“Fah Hian mentions that pirates were numerous in those seas (*Ib.*, I, lxxx.), which shows that the commerce must have been considerable” (p. 171).

“It seems in the highest degree improbable that this close connection between the Sun and the serpent could have originated, independently, in countries so far apart as China and the West of Africa, or India and Peru. And it seems scarcely possible that, in addition to this, the same forms of worship of these deities, and the same ritual, could have arisen, spontaneously, amongst each of these far distant peoples. The alternative appears to be that the combined worship of the Sun and serpent-gods must have spread from a common centre, by the migration of, or communication with, the people who claimed Solar descent.

“So universally was the Naga held sacred, that it would seem to have been the earliest totem of the people who claimed descent from the Sun-god” (p. 183).

I have quoted so extensively from Oldham's fascinating work because the conclusions at which he arrived from a study of the ancient literature of India is confirmed

by evidence derived from utterly different sources, not only from India itself but also from other countries. For, scattered throughout the length and breadth of India, are to be found thousands of indications (in traditions, beliefs, customs, social organisation and material relics) that the complete "heliolithic" culture had reached India not later than the beginning of the seventh century B.C.

Moreover the evidence which I have culled from Oldham bears out the conclusions my own investigations lead up to, namely, that the "heliolithic" culture spread from India to Malaysia soon after it reached India itself. It is surely something more than a mere coincidence that the period of the greatest maritime exploits of the Phœnicians, in the course of which, according to many authorities, they reached India or even further east, should coincide with that of the great pre-Aryan maritime race of India, whose great expeditions, as the above quotations indicate, were primarily for purposes of commerce between the Persian Gulf and the West Coast of India. There is gradually accumulating a considerable mass of evidence to suggest that, if the Asuras were not themselves Phœnicians, they acquired their maritime skill from these famous sailors and traders. The same hardy mariners who brought the new knowledge and practices from the Persian Gulf to India and Ceylon also carried it further, to Burma and Indonesia.

That this is so is clearly shown by the fact that these customs spread to Indonesia and the Pacific *before* cremation was introduced; and it has been indicated above that the introduction of the practice of cremation into India may have taken place within a century of the arrival of the "heliolithic" civilization there. Hence it is obvious that the latter must have spread to the far east soon after it reached India; and the completeness of the

transmission of the distinctive culture-complex can be explained only by supposing that the same people who brought it to India also carried it further east.

All the other evidence at our disposal is in full harmony with this view. The advancing wave of western culture swept past India into Indonesia, carrying into the isles of the Pacific and on to the American littoral the products of the older civilizations at first almost, but not altogether, untainted by Indian influence; but for centuries afterwards, as this same ferment gradually leavened the vast bulk of India, the stream of western culture continued to percolate eastwards and carried with it in succession the influence of the Brahmanical, Buddhist and, within in a more restricted area, Mahometan cults.

It is an interesting confirmation of the general accuracy of the scheme that has now been sketched out that the dates at which the influence of Egypt began to be exerted in the east, that to which Rhys Davids assigns the definite influencing of India by Babylonia, that at which India influenced Malaysia, and finally that assigned by students of the Polynesian problem to the inauguration of the great Indonesian migration into the Pacific (60 and 98), all fit into one consecutive series, though each was determined from different kinds of evidence and independently of the rest.

It is not my intention to discuss the evidence for the coming of the "heliolithic" culture to Indonesia, for the complex problems of this region have been analysed and interpreted in a masterly fashion by W. J. Perry in a book which is shortly to be published. The form which my present communication has assumed is largely the outcome of the reading of Perry's manuscript and of discussions with him of the new lines of investigation which it suggested; and I am satisfied to leave this region

for him to elucidate in detail. It will suffice to say here that the traditions of the inhabitants of the various islands of Malaysia, no less than their heterogeneous customs and beliefs, provided him with very precise evidence in demonstration of the complex constitution of the "helio-lithic" culture, and of the fact that it was brought to the islands by an immigration from the west.

There is less need for me to analyse the vast literature relating to the burial practices in the islands of the Malay Archipelago since this useful service has already been accomplished by Hertz (33). Although I dissent from the main contention in his interpretation of the facts, his accurate record is none the less valuable on that account—perhaps indeed it is more useful, as it certainly cannot be accused of bias in favour of the views I am expounding.

A great variety of burial customs, in most respects closely analogous to the practices of the Naga tribes of India, is found in Indonesia ;—exposing the dead on trees or platforms, burial in hollow trees, smoking and other methods of preservation, temporary burial, and cremation.

Apart from the definite evidence of preservation of the dead found in scattered islands from one end of the Archipelago to the other, there are much more generally diffused practices which are unquestionably derived from the former custom of mummification.

In the account of mummification as practised in the more savage African tribes, it was seen that the practice was restricted in most cases to the bodies of kings ; and even then the failure to preserve the body in a permanent manner compelled these peoples to modify the Egyptian methods. Realising that the corpse, even when preserved as efficiently as they were able to perform the work of embalming, would undergo a process of disintegration within a few months, it became the practice to rescue the

skull, to which special importance was attached (for the definite reasons explained by the early Egyptian evidence).

In his survey Hertz (33, p. 66) calls attention to the widespread custom of temporary burial throughout Indonesia, but, instead of recognising that such procedures have come into vogue as a degradation of the full rites incidental to mummification, he regards it as part of a widespread "notion que les derniers rites funéraires ne peuvent pas être célébrés de suite après la mort, mais seulement à l'expiration d'une période plus ou moins longue" (p. 66); and regards mummification simply as a specialised form of this rite which is almost universal (p. 67):—"il paraît légitime de considérer la momification comme un cas particulier et dérivé de la sépulture provisoire." (p. 69). This is a remarkable inversion of the true explanation. For the enormous mass of evidence which is now available makes it quite certain that the practice of temporary burial was adopted only when failure (or the risk of failure) to preserve the body compelled less cultured people to desist from the complete process.

I am in full agreement with Hertz when he says:—"L'homologie entre la préservation artificielle du cadavre et la simple exposition temporaire paraîtra moins difficile à admettre si l'on tient compte du fait qui sera mis en lumière plus bas : les ossements secs, résidu de la décomposition, constituent pour le mort un corps incorruptible, absolument comme la momie." (p. 69). But does not this entirely bear out my contention? It is quite inconceivable that the practice of mummification could have been derived from the custom of preparing the skeleton; but the reverse is quite a natural transition, for even in the hands of skilled embalmers (see especially 39), not to mention untutored savage peoples, the measures taken for

preserving the body may fail and the skeleton alone may be spared. If this contention be conceded, the demonstration given by Hertz of the remarkable geographical distribution of customs of temporary burial affords a most valuable confirmation of the general scheme of the present communication. "Au point de vue où nous sommes placés, il y a homologie rigoureuse entre l'exposition du cadavre sur les branches d'un arbre, telle que la pratiquent les tribus du centre de l'Australie, ou à l'intérieur de la maison des vivants, comme cela se rencontre chez certains Papous et chez quelques peuples Bantous, ou sur une plateforme élevée à dessein, ainsi que le font en général les Polynésiens et de nombreuses tribus indiennes de l'Amérique du Nord, ou enfin l'enterrement provisoire, observé en particulier par la plupart des Indiens de l'Amérique du Sud" (p. 67). There can be no doubt whatever of the justice of this "homology," for in every one of the areas mentioned these customs exist side by side with the practice of mummification; and in many cases there is definite evidence to show that the other methods of treatment have been derived from it by a process of degradation. In his excellent bibliography, and especially the illuminating footnotes, Hertz gives a number of references to the practice of desiccation by smoking or simple forms of embalming which had escaped me in my search for information on these matters. He refers especially to further instances of such practices in Australia, New Guinea, various parts of West Africa, Madagascar and America (p. 68).

An interesting reference in the same note (p. 68, footnote 5) is to the practice of simple embalming among the Ainos of Sakhalin (Preuss, *Begräbnisarten der Amerikaner*, p. 190). This seems to supply an important link between the Eastern Asiatic littoral and the Aleutian

Islands, where mummification is practised. In Saghalien, according to St. John ("The Ainos," *Journ. Anthropol. Inst.*, Vol. II., 1873, p. 253), "when the chief of a tribe or village died, his body was laid out on a table close to the door of his hut; his entrails were then removed, and daily for twelve months his wife and daughters wash him thoroughly. He is allowed . . . to dry in the sun."

In a recent article on the customs of the people of Laos (G. Maupetit, "Moeurs laotiennes," *Bull. et Mem. de la Soc. d'Anthropol. de Paris*, 1913), an account is given of the practice of mummification in this far south-eastern corner of the Asiatic mainland. Cremation is the regular means adopted for disposal of the dead: but it is also "the Laotian's ideal to be able to preserve the corpse in his house, for as long a time as possible, before incinerating it: in the same way the Siamese and Chinese keep their dead in the house for several months, often for several years" (p. 549).

According to Maupetit the method of preservation is a most remarkable one. They pour from 75 to 300 grammes of mercury into the mouth! "It passes along the alimentary canal and suffices to produce mummification, the rapid desiccation of the organic tissues." Then the body was stretched upon a thick bed of melted wax, wood ashes, cloth and cushions.

The great stream of "heliolithic" culture exerted a profound influence upon and played a large part in shaping the peculiar civilizations of China, Corea, and Japan. As the practice of embalming does not play an obtrusive part¹⁵ in this influence, I do not propose (in the present communication) to enter upon the discussion

¹⁵ Reutter (63) quotes the statement from Tschirch that Neuhof has described the embalming of bodies in Asia. In Borneo camphor, areca nut and the wood of aloes and musk are used; and in China camphor and sandalwood.

of these matters, except to note in passing that the influence exerted by the "heliolithic" culture upon the Pacific coast of America may have been exerted partly by the East Asiatic-Aleutian route (see *Map II.*).

The disgusting practice of collecting the fluids which drip from the putrefying corpse and mixing them with the food for the living occurs in Indonesia, in New Guinea and the neighbouring islands, in Melanesia, Polynesia and in Madagascar (for the bibliographical references see Hertz, p. 83, footnote 3).

The Indonesian methods of preserving the dead are found in Seram (W. J. Perry), and the report recently published by Lorenz¹⁶ (43, p 22) records a similar practice in the neighbourhood of Doré Bay in North-West New Guinea. The corpse was tied to the rafter of the dwelling-house; and the practice of mixing the juices of decomposition with the food is in vogue also. The accounts given by D'Albertis (1) and other travellers show that analogous customs are found at other places in New Guinea. There can be no doubt that the practice spread along the north coast of the island and then around its eastern extremity to reach the islands of the Torres Straits, where the practice is seen in its fully developed form, as Flower (19), Haddon and Myers (25), and Hamlyn-Harris (27) have described.

As I have already referred to Papuan mummies earlier in this communication and at some future time intend to devote a special memoir to the full discussion of the methods of the Torres Straits embalmers, I shall not go into the matter in detail here. I should like, however, to call special attention to the admirable account given by Haddon and Myers (25) of the associated funeral rites.

¹⁶ For this and certain other references I have to thank my colleague Professor S. J. Hickson, F.R.S. So far I have been unable to consult the full reports of Lorenz's expedition.

In his memoir Flower described two interesting mummies, then in the Museum of the Royal College of Surgeons in London, one "brought in 1872 from Darnley Island in Torres Strait by Mr. Charles Lemaistre, Captain of the French barque 'Victorine,' and the other, an Australian mummy, obtained in 1845 near Adelaide, by Sir George Grey." By a curious and utterly incomprehensible act of vandalism these extremely rare and priceless ethnological specimens were deliberately destroyed by Sir William Flower, who naively explains his extraordinary action by the statement "as the skeleton will form a more instructive specimen when the dried and decaying integuments are removed I have had it cleaned" (p. 393)! He treated in the same manner the second mummy, the only example of its kind, so far as I am aware, in this country! His photographs show that these two specimens, so far from being "decaying," were in a remarkably good state of preservation at the time he doomed them to destruction.

Captain Lemaistre found the Torres Strait mummy "in its grave, which consisted of a high straw and bamboo hut of round form: it was not lying down, but standing up on the stretcher" (19, p. 389). This is a close parallel to the African customs—mummification, burial in a house of round form, and fixing the corpse to a rough form of funeral bier, which is stood up in the house.

The skin was painted red, the scalp black. "The sockets of the eyes were filled with a dark brown substance, apparently a vegetable gum. . . . In this was imbedded a narrow oval piece of mother of pearl, pointed at each end, in the centre of the anterior surface of which is fixed a round mass of the same resinous substance, representing the pupil of the eye" (p. 301).

"Both nostrils had been distended."

"In the right flank was a longitudinal incision, $3\frac{1}{2}$ inches in length, extending between the last rib and the crest of the ilium. This had been very neatly closed by what is called in surgery the interrupted suture. . . . The whole of the pelvic, abdominal and thoracic viscera had been removed, and their place was occupied by four pieces of very soft wood. . . . Except the wound in the flank, there was no other opening or injury to the skin" (p. 391).

"Heads and bodies prepared in a similar way" are found in many museums, and afford an interesting illustration of the old Egyptian practice of paying special attention to the head. This is all the more instructive in view of the fact that it was common in certain regions, especially Mallicolo in the New Hebrides, to restore the features by means of clay and resinous paste, usually making use of the skull as a basis, but occasionally modelling the whole body,¹⁷ the model including parts of the deceased's skeleton (see Henry Balfour's article, "Memorial Heads in the Pitt Rivers Museum," *Man*, Vol. I., 1901, p. 65). These modelling-practices and especially the fact that they usually deal with the head (or even face) only afford an interesting confirmation of the Egyptian origin of these customs (*vide supra*, etc., 40).

In the 6th volume of the reports of the Cambridge Anthropological Expedition to Torres Straits, C. S. Myers and Haddon (25, pp. 129 and 135) give a detailed account of the funeral ceremonies from which I quote certain points. "As soon as death had occurred the women of the village started wailing. The corpse was placed on the ground on a mat in front of the house; the arms were placed close to the side; the great toes were tied together

¹⁷A curious feature of these models is the representation of faces on the shoulders. Similar practices have been recorded in America (Bancroft, 3).

by a string ; the hair of the head and face was cut off and thrown away ; the length of the nose was then measured with a piece of wax, which was preserved by a female relative for subsequent use in making a wax mask for the prepared skull. The dead man's bow and arrow and his stone-headed club were laid beside him" (p. 129). The Egyptian analogies in all of these procedures is quite obvious.

"Five men wearing masks performed a series of manœuvres ending up with flexion of the arms and a bending of the head. This movement was said to indicate the rising and setting of the sun and to be symbolic of the life and death of man.

"Mourners then took the body and placed it upon a wooden framework, which stood upon four wooden supports at a little distance from the house of the deceased. The relatives then took large yams and placed them beside the body on the framework ; they also hung large bunches of bananas upon the bamboos around. This was regarded as nourishment for the ghost, which was supposed to eat it at night-time (p. 135).

"In two or three days when the skin of the body had become loose the framework was taken up to the reef in a small canoe ; the epidermis was then rubbed off and by means of a sharp shell a small incision was made in the side of the abdomen (in the right side, at least, in the case of women), whence the viscera were extracted.

"The perineum was incised in the males."

From a study of all the literature regarding this custom, as well as the actual specimens now in Sydney and Brisbane, it is clear that the incision may be made either in the left or right flank or in the perineum, and that sex does not determine the site.

"The abdominal cavity was then filled up with pieces

of Nipa palm ; the viscera were thrown into the sea and the incision closed by means of fine fish line. An arrow was used to remove the brain, partly by way of the foramen magnum and partly through a small slit which was made in the back of the neck. The 'strong skin' of the brain (the dura mater) was first cut and then the 'soft skin' was pulled out.

"The body was then brought back to the island and was placed in a sitting position upon a stone ; the entire body was then painted with a mixture of red earth and sea water. The head, body and limbs were then lashed to the framework with string and a small stick was affixed to the lower jaw to keep it from drooping. The framework, with its burden, was fastened vertically to two posts set up in the rear of the house, and it was protected from public view by a screen of coconut leaves. The body was then gently rubbed down and holes were made with the point of an arrow so that the juices might escape. A fire was always kept alight beneath the body, 'by-n-by meat swell up' (p. 136).

"D'Albertis (I) saw in Darnley Island the mummy of a man, who had been dead over a year, standing in the middle of the widow's house attached to a kind of upright ladder of poles. They tint him from time to time with red chalk (ochre) and keep his skin soft by anointing it with coconut oil" (p. 137).

In the Berlin Museum für Volkerkunde there are mummies of two children, photographs of which, obtained from Professor von Luschan, are reproduced by Dr. Haddon. They were given to Dr. Bastian by the Rev. James Chamlers in 1880, having been obtained at Stephen's Island. One of them is a small girl a few days old. The body is painted red all over, except the scalp and eyebrows, which are blackened. The other one was

a small girl two or three years of age treated in a similar way; the incision for embalming is on the *left* side and has been sewn up.

“In 1845 Jukes saw on the lap of a woman of Darnley Island the body of a child a few months old which seemed to have been dead for some time. It was stretched on a framework of sticks and smeared over with a thick red pigment, which dressing she was engaged in renewing. (“Voyage of the ‘Fly,’” Vol. I., 1847, p. 246)” (p. 138).

“Macgillivray (“Voyage of the ‘Rattlesnake,’” Vol. II., 1852, p. 48) also refers to a mummy of a child in Darnley Island. Sketches of the two Miriam mummies in the Brisbane Museum will be found on Plate 94 of Edge Partington and Heape’s *Ethnographical Album of the Pacific Islands*, third series. [Compare also Plate 2, Figure 4, in Brockett’s “Voyage to Torres Straits,” Sydney, 1836]” (p. 137).

“On about the tenth day after death, when the hands and feet have become partially dried, the relatives, using a bamboo knife, remove the skin of the palms and soles, together with the nails, and then cut out the tongue, which is put into a bamboo clamp so that it may be kept straight while drying. These were presented to the widow, who henceforth wore them” (p. 138).

A great deal of further information in regard to this practice is given by Haddon and Myers in their important monograph. Among other things they call attention once more to the custom of preserving the skull in the Torres Straits Islands where mummification is practised. The use of masks and ceremonial dances to assist the performers so as the more realistically to play the part of the deceased is welcome confirmation of the conclusion drawn from geographical distribution that such practices

were intimately related to mummification and form part of the ritual genetically linked to it.

Dr. Hamlyn-Harris, the Director of the Queensland Museum, gives an account (27) of the two mummies from the Torres Straits, which are now in Brisbane; and he adds further interesting information which he obtained from Mr. J. S. Bruce, of Murray Island, who was also one of Dr. Haddon's informants. During my recent visit to Australia Dr. Hamlyn-Harris very kindly gave me every facility for examining these two mummies (as well as the Australian mummies in the Queensland Museum); and I also examined another specimen in the Macleay Museum of the University of Sydney. I am preparing a full report on all of these interesting specimens.

From the Torres Straits the practice of mummification spread to Australia, as Flower (19), Frazer (22), Howitt (see Hertz, 33), Roth (71) and Hamlyn-Harris (28), among others, have described. Roth says "Desiccation is a form of disposal of the dead practised only in the case of very distinguished men. After being disembowelled and dried by fire the corpse is tied up and carried about for months." (71, p. 393). The mummy was painted with red ochre (Fraser, 22).

In Roth's photographs, as well as in the mummies which I have had the opportunity of examining, the embalming-incision was made in the characteristically Egyptian situation in the left flank. In one of the mummies in the Brisbane Museum (see 28, plate 6) the head is severely damaged. Examination of the specimen indicates that incisions had been deliberately made. Perhaps it was an attempt to remove the brain, which ended in destruction of the cranium.

A curious feature of Australian embalming is that the body was always flexed, and not extended as in the Torres

Straits. At first I was inclined to believe that this may be due to the influence of the Early Egyptian (Second Dynasty) procedure (89), but a fuller consideration of the evidence leads me to the conclusion that the adoption of the flexed position is due to syncretism with local burial customs, which were being observed when the bringers of the "heliolithic" culture reached Australia. It is probable that the boomerang came from Egypt, *via* East Africa, India (12) and Indonesia at the same time.

Several curious burial customs which may be regarded as degradations of the practice of mummification occur in Australia, but the consideration of these I must defer for the present.

In the discussion on Flower's memoir (19), Hyde Clarke justly emphasized "the importance of the demonstrations in reference to their bearings on the connection of the Australian populations with those of the main continents, and in the influence exerted in Australasia at a former time by a more highly cultivated race. This, to his mind, was the explanation of the relations of the higher culture, whether with regard to language, marriage and kindred, weapon names, or modes of culture, such as the mummies now described, the modes of incision, and form of burial. He did not consider these institutions, as some great authorities did, indigenous in Australia" (19, p. 394).

Corroborative evidence is now accumulating (70), which will definitely establish the reality of the influence thus adumbrated by Clarke 37 years ago.

Frazer (22, p. 80) says the burial (in Australia) on a raised stage reminds him of the "towers of silence," and adds:—"This novelty of a raised stage can scarcely be a thing which our blacks have invented for themselves since they came to Australia; and, if it is a custom which

some portion of their ancestors brought with them into this country, I would argue from it that these ancestors were once in contact with, or rather formed part of, a race which had beliefs similar to those of the Persians; such beliefs are not readily adopted by strangers; they belong to a race." Frazer proceeds to contrast this practice with the other Australian custom of desiccation, which, he says, "corresponds to the Egyptian practice of mummification" (p. 81): but, as Hertz (33 *et supra*) has pointed out, they were inspired by the same fundamental idea, however much the present practitioners of the two methods may fail to realize this in their beliefs and traditions. The interesting suggestion emerges from these considerations that the peculiar Persian burial customs may be essentially a degraded and profoundly modified form of the ancient Egyptian funerary rites.

In his "Polynesian Researches" William Ellis (15) gives an interesting, though unfortunately too brief, account of the Tahitian practice of embalming. Among the poor and middle classes "methods of preservation were too expensive" to be used, but the body was "placed upon a sort of bier covered with the best native cloth" while awaiting burial (p. 399).

"The bodies of the dead, among the chiefs, were, however, in general preserved above ground: a temporary house or shed was erected for them, and they were placed on a kind of bier . . . sometimes the moisture of the body was removed by pressing the different parts, drying it in the sun, and anointing it with fragrant oils. At other times, the intestines, brains, etcetera were removed: all moisture was extracted from the body, which was fixed in a sitting position during the day, and exposed to the sun, and, when placed horizontally at night was frequently turned over, that it might not remain long on the same

side. The inside was then filled with cloth saturated with perfumed oils, which were also injected into other parts of the body, and carefully rubbed over the outside every day" (pp. 400 and 401).

"It was then clothed, and fixed in a sitting posture ; a small altar was erected before it, and offerings of fruit, food and flowers, were daily presented by the relatives, or the priests appointed to attend the body. In this state it was preserved several months, and when it decayed, the skull was carefully kept by the family, while the other bones etc. were buried within the precincts of the family temple" (p. 401).

Ellis makes the significant comment:—"It is singular that the practice of preserving the bodies of their dead by the process of embalming, which has been thought to indicate a high degree of civilization, and which was carried to such perfection by one of the most celebrated nations of antiquity, some thousand years ago, should be found to prevail among this people." The whole of the circumstances attending the practice of this custom, and the curious ritual and the behaviour of the mourners, as described by Ellis, no less than the details of the process, in fact afford the most positive evidence of its derivation from Egypt.

Ellis says "it is also practiced by other distant nations of the Pacific, and on some of the coasts washed by its waters." "In some of the islands they dried the bodies, and, wrapping them in numerous folds of cloth, suspended them from the roofs of their dwelling-houses" (p. 406).

Ellis notes the remarkable points of identity between the Tahitian account of the deluge and not only the Hebrew but also those of the Mexicans and Peruvians and many other peoples (p. 394).

In Glaumont's summary (24, p. 517) five modes of

burial are described as being practised in New Caledonia. The first is burial in the flexed position; 2nd, extended burial in caves; 3rd, exposure of the body in trees or on the mountains; 4th, mummification; 5th, the body erect or reposing in a dug-out canoe. With regard to the method of embalming, this is practised only in the case of a chief. The body of a chief soon after death was covered with pricks into which were introduced the juices of certain plants with the object of preventing decomposition of the tissues. Afterwards the body was suitably dried or smoked, then it was dressed in its best clothes, its face painted red and black, and then the body was preserved indefinitely. A hole was made at the top of the hut, and by means of this they haul up the mummy. After it has been exposed in this way for a certain time, the body was withdrawn from the hole into the house, which was then carefully shut up and became taboo with all that it contained. Analogous customs are found in New Zealand and elsewhere in Oceania. A singularly strange custom is now in use in the New Hebrides and in the Solomon Islands. The father and son, for example, or the husband and wife, having just died, they smoke the head alone as in New Zealand, but they make (with bamboo covered with cloth) a mannikin, having roughly the human form; then they tattoo the whole of the surface; fastened upon each shoulder—and this is the strange part of it—is a piece of bamboo, to one of which they attach the father's head and the other that of his son. [The account is not altogether intelligible here.] The heads are painted white and black. With reference to the placing of the body in a canoe, this is reserved for chiefs only. When a chief dies, messengers go in all directions, repeating "The sun is set." This expression springs from the idea that the chief is a god, the supreme Sun-god.

These procedures afford a remarkably complete series of links with the "heliolithic" cult as practised elsewhere in the west and east. The account of the curious attachment of the heads to the shoulders of the dummy figure throw some light upon the custom (to which I have referred elsewhere in this communication) in Mallicolo (61, p. 138) and in America of representing human faces on the shoulders of such models. It is a remarkable fact that in certain of the Mallicolo figures the phallus is fixed to the girdle in a very curious manner, exactly analogous to that recently described and figured by Blackman from an Egyptian tomb of the Middle Kingdom at Meir.

Embalming was a method rarely employed in New Zealand.

"After the extraction of the softer parts, oil or salt was rubbed into the flesh, and the body was dried in the sun or over a fire; then the mummy was wrapped in cloth and hidden away."

"In some parts of New Zealand the skeletons of mummified bodies are found in the crouching or sitting posture" (Macmillan Brown, 7, p. 70).

In Schmidt's *Jahrbücher der gesammten Medicin*, 1890, Bd. 226, p. 175, there is an abstract of an article on Samoa by P. Burzen in which, among other things, the three Egyptian operations of circumcision, massage and mummification are described as being practiced.

The embalming is done by women. After removing the viscera, which are buried or burnt, the eviscerated corpse is then soaked for two months in coco-nut oil, mixed with vegetable juices. When the body is fully treated and no more fluid escapes from it, the hair which had previously been cut off, is stuck on again with a resinous paste. The body cavity is packed with cloth

soaked in vegetable oil and resinous materials: then the mummy is wrapped up with bandages, the head and hands being left exposed.

The body so prepared is put in a special place where it is preserved indefinitely.

"In Pitcairn Island 1,400 miles due west of Easter Island carved stone pillars or images of a somewhat similar character to those of Easter Island" are found (Enoch, 16, p. 274).

"Another 1,400 miles to the north-west takes us to Tahiti. The natives of Tahiti buried their chiefs in temples; their embalmed bodies, after being exposed, were interred in a couching position. Mention is made of a pyramidal stone structure, on which were the actual altars, which stood at the farther end of one of the squares."

"There are many close analogies between the sacrificial practices and those of Mexico" (p. 275).

In their extensive migrations the carriers of the "heliolithic" culture took with them the custom of circumcision, and introduced it into most of the regions where their influence spread. In some of the areas affected by the "heliolithic" leaven the more primitive operation of "incision" is found. This consists not of removing the prepuce, but merely slitting up its dorsal aspect (69, p. 432). It was the method employed in Egypt in pre-dynastic times, when it was the custom to hide the phallus in a leather sheath suspended from a rope tied round the body. The practice of "incision" and the use of the pudendal sheath persists in some parts of Africa until the present day (see *Journ. Roy. Anthropol. Instit.*, 1913, p. 120).

Rivers claims that "the practice of incision arose in Oceania as a modification of circumcision" (69, p. 436): but I think the possibility of it having been introduced

from the west along with or before the practice of circumcision needs to be considered.

Another remarkable practice which probably formed part of the equipment of the heliolithic wanderers was massage. It was employed by the Egyptians as early as the Sixth Dynasty, as we know from the representations of the operations in a Sakkara *mastaba* (Capart, II). Piorry (57) has given an account of the wide range of the practice of massage, from Egypt to India, China and Tahiti, and the high state of efficiency attained in its use in ancient times in India and China. The Chinese manuscript *Kong-Fau* contained detailed accounts of the operation. Piorry remarks, "it is clear that for us its development did not originate from the practices described in the books of Cong-tzée or the compilation of Susrata."

From Rivers' interesting account of massage in Melanesia (67) it is evident that the method must have an origin common to it and the modern European practice, and that it could not have arisen amongst a barbarous people like the Melanesians, who have the most extraordinary conceptions as to why and how it serves a therapeutic purpose. Although we have no evidence to prove that massage spread along with the heliolithic culture, the fact that it has a similar geographical distribution, and certainly was extensively practised in Egypt long before the great migration began, suggests that it may represent another Egyptian element of that remarkable culture-complex.

In his masterly analysis of the cultures of Oceania (69) Rivers has given a useful summary of the evidence relating to the practice of preserving the body, and has drawn certain inferences from these and other burial practices, which I propose to examine. "In some cases, as in

Tikopia, interment takes place either in the house or within a structure representing a house, while in Tonga and Samoa the bodies of chiefs are interred in vaults built of stone. Often the body is buried in a canoe or in a hollowed log of wood, which represents a canoe" (69, p. 269). From the evidence to which reference has been made in the course of the present memoir it is unnecessary to insist at any length on the importance and obvious significance of these facts. But I question the inference Rivers draws (p. 270) from the burial in boats. He says "the practice can be regarded as a result of the fact of migration, and does not show that the use of a canoe was the practice of the immigrants in their original home." The practice is so wide-spread, however, and in Egypt and elsewhere had such a deep-rooted significance that it is difficult to believe this custom was not brought by the immigrants with them. I am willing to admit that the special circumstances of the people of Oceania naturally emphasized what may be called the "boat-element" in the funerary ritual; but the association of the use of boats with burial is so curious and constant a feature of the "heliolithic" culture wherever it manifests itself (*vide supra*) as hardly to have arisen independently in different parts of the area of distribution.

"A second mode or treatment is preservation of the body, either in the house or on a stage often covered with a roof. Some kind of mummification is usually practised in these cases, by continual rubbing with oil, drying by means of a fire, and puncture of the body to hasten the disappearance of the products of decomposition."

"In some parts of Samoa there is a definite process of embalming in which the viscera are removed and buried. A body thus treated lies on a platform resting upon a double canoe, and in many other places a canoe is used

as a receptacle for the body while it is undergoing the process of mummification" (p. 269). This association of the use of a canoe with a method of preservation obviously Egyptian in origin naturally provokes comparison with the use of boats in the Egyptian funeral ceremonies. An instance is the boat found in the tomb of Amenophis II. (81). The platform is probably a type of bed found elsewhere in the region under consideration (see, for instance, Roth's account of the Queensland sleeping-platform) and represents the bier found so often elsewhere (*vide supra*). This is in no way inconsistent with Rivers' view that "exposure of the dead on platforms is only a survival of preservation in a house" (p. 273).

Earlier in this memoir I have explained why the Egyptians came to attach special importance to the head, and how the less cultured people of Africa, when faced with the difficulties of preserving the body, saved the skull (or in some cases the jaw). When it is recalled how widespread this custom is in other parts of the "heliolithic area," and how deep-rooted were the ideas which prompted so curious a procedure, Rivers' independent inference in regard to this matter is fully confirmed. "Many practices become intelligible as elements of a single culture if we suppose that a people imbued with the necessity for the preservation of the body after death acquired . . . the further idea that the skull is the representative of the body as a whole ; if they came to believe that the purpose for which they had hitherto preserved the body could be fulfilled as well if the head only were kept" (p. 273). This is unquestionably true : but I dissent from Rivers' qualification that this modification happened "perhaps in the course of their wanderings towards Oceania," because it has already been seen that it had occurred before the

wanderers set out from the East African coast. There is, of course, the possibility that Africa may have been influenced by a cultural reflux from Indonesia, such as has been demonstrated in the case of Madagascar; but there are reasons for believing that the facts under consideration cannot be explained in this way.

In thus venturing upon criticisms of Rivers' great monograph I should like especially to emphasize the fact that these comments do not refer in any way to his attack on the "orthodox" ethnological position. On the contrary, the views that I am setting forth in this communication represent a further extension of Rivers' own attitude that the Oceanic cultures have been derived mainly from contacts with other peoples. A series of practices which he has hesitated to recognise as having been introduced, but inclined to regard as local developments, I hold to be part of the immigrant culture. The use of boats for burial, the custom of regarding the head as an efficient representative of the whole body and the practice of "incision" as well as circumcision (69, p. 432) are examples of customs, which he regards as local developments in the Pacific: but all three are equally distinctive of Ancient Egypt and occur at widely separated localities along the great "heliolithic" track. The linking-up of sun-worship with all the other elements of the "heliolithic cult" also compels me to question his limitation of such worship to certain regions only in Oceania (69, p. 549); even though I fully admit that the data used by Rivers are not sufficient to justify any further inference than he has drawn from them.

My aim is then, not an attempt to weaken Rivers' general attitude, but enormously to strengthen it, by demonstrating that each culture-complex was brought into the Pacific in an even more complete form than

he had postulated. Nor does my criticism affect his hypothesis of a series of cultural waves into Oceania. Here, again, I am prepared to go not only the whole way with him, but even further, and to seek for additional cultural influences which he has not yet defined.

Most modern writers who refer in any way to the preserved bodies which have been found in vast numbers in Peru and in other parts of America assume that these bodies have been preserved not by embalming or any other artificial method or mode of treatment, but simply as the result of desiccation by the unaided forces of nature. Although in the great majority of cases there are no obvious signs of any artificial means having been employed to preserve the bodies, yet a not inconsiderable number of examples have come to light to demonstrate the reality of the practice of mummification in America (3: 37: 58: 63: and 106). Yarrow's classical monograph (106) established the reality of the practice of embalming in America quite conclusively. Moreover the fact that practically every item of the multitude of curiously distinctive practices found widespread in other parts of the world, in the most intimate association with methods of embalming certainly inspired by Egypt, puts it beyond all reasonable doubt that the variety of American practices for preserving the body is also to be attributed to the same source.

In his book on the "History of the Conquest of Peru," Prescott makes the following statement:—"When an Inca died (or, to use his own language, was called home to the mansion of his father, the Sun) his obsequies were celebrated with great pomp and solemnity. The bowels were taken from the body and deposited in the Temple of Tampu, about five leagues from the capital. A quantity of his plate and jewels was buried with him, and a number

of his attendants and favourite concubines, amounting sometimes, it is said, to a thousand, were immolated on his tomb

“The body of the deceased Inca was skilfully embalmed and removed to the great Temple of the Sun at Cuzco. There the Peruvian sovereign on entering the awful sanctuary might behold the effigies of his royal ancestors, ranged in opposite files—the men on the right and their queens on the left of the great luminary which blazed in refulgent gold on the walls of the temple. The bodies, clothed in princely attire which they had been accustomed to wear, were placed on chairs of gold, and sat with their heads inclined downwards, their hands placidly crossed over their bosoms, their countenances exhibiting their natural dusky hue—less liable to change than the fresher colouring of a European complexion—and their hair of raven black, or silvered over with age, according to the period at which they died. It seemed like a company of solemn worshippers fixed in devotion, so true were the forms and lineaments to life. The Peruvians were as successful as the Egyptians in the miserable attempt to perpetuate the existence of the body beyond the limits assigned to it by nature. [Note.—Ondegardo, *Rel. Prim.*, MS.—Garcilasso, *Com. Real.*, parte i., lib. v., cap. xxix. The Peruvians secreted their mummies of their sovereigns after the Conquest, that they might not be profaned by the insults of the Spaniards. Ondegardo, when corregidor of Cuzco, discovered five of them, three males and two females. The former were the bodies of Viracocha, of the great Tupac, Inca Yupanqui, and of his son, Huayna Cupac. Garcilasso saw them in 1650. They were dressed in their regal robes, with no insignia but the llautu on their heads. They were in a sitting position, and, to use his own expression, ‘perfect as life, without so

much as a hair of an eyebrow wanting.' As they were carried through the streets, decently shrouded with a mantle, the Indians threw themselves on their knees, in sign of reverence, with many tears and groans, and were still more touched as they beheld some of the Spaniards themselves doffing their caps in token of respect to departed royalty. (*Ibid. ubi supra.*) The bodies were subsequently removed to Lima; and Father Acosta, who saw them there some twenty years later, speaks of them as still in perfect preservation]" (58, pp. 19 and 20).

Later on in the same work Prescott, relying again on the somewhat questionable authority of Garcilasso's works, makes a statement which in some respects may seem to be at variance with what I have just quoted:—

"It was this belief in the resurrection of the body which led them to preserve the body with so much solicitude—by a simple process, however, that unlike the elaborate embalming of the Egyptians, consisted in exposing it to the action of the cold, exceedingly dry and highly rarified atmosphere of the mountains. [Note.—Such indeed seems to be the opinion of Garcilasso, though some writers speak of resinous and other applications for embalming the body. The appearance of the royal mummies found at Cuzco, as reported both by Ondegardo and Garcilasso, makes it probable that no foreign substance was employed for their preservation.] As they believed that the occupations in the future world would have great resemblance to those of the present, they buried with the deceased noble some of his apparel, his utensils, and frequently his treasures; and completed the gloomy ceremony by sacrificing his wives and favourite domestics to bear him company and do him service in the happy regions beyond the clouds. Vast mounds of an irregular or more frequently oblong shape, penetrated

by galleries running at right angles to each other were raised over the dead, whose dried bodies or mummies have been found in considerable numbers, sometimes erect, but more often in the sitting posture common to the Indian tribes of both continents" (p. 54).

In the light of the information concerning the practices in other parts of the world, which I have collected in the present memoir, there can be no doubt of the substantial accuracy of these reports, and that they refer to real embalming and not to mere natural desiccation.

Hrdlička has adduced positive evidence of the adoption of embalming procedures (37).

In his report, "Culture of the Ancient Pueblos of the Upper Gila River Region, New Mexico and Arizona," Walter Hough (36) publishes excellent photographs of two mummies of babies, but he gives no information as to the method of preservation.

There are four Peruvian mummies in the Anatomical Museum in the University of Manchester, three of which are adults, and one of them a baby. In only one of them is there any positive evidence of artificial measures having been adopted for the preservation of the body, and in this case the condition of the mummy was a most amazing one. The body was clad in woollen garments in the usual way, and was wearing a woollen peaked cap, the apex of which was furnished with a bunch of feathers. The body was placed in a sitting position, and a large wound extending across the trunk had been covered with cloth strongly impregnated with resinous material. The legs were sharply flexed upon the body and the arms were bound up in front. But to my intense amazement I found the shoulder blades on the front of the chest, and on examination found that the thorax was turned back to front. As the head was already separate there was

nothing to show what position it originally occupied ; and it seemed impossible to explain how it had been possible to twist the vertebral column in the lumbar region as to bring the thorax back to front. In order to solve this mystery I removed the resin-impregnated cloth, which was firmly fixed to the abdominal wound, and found that the body had been cut right across the abdomen and packed with wool after the viscera had been removed. Then the abdomen and thorax had been stuck together by means of the broad strip of cloth with resinous paste as an adhesive. But for some reason which is not very apparent, or probably through mere carelessness, the thorax had been placed the wrong way round, and it had become necessary, in order to restore some semblance of life-like appearance to the monstrosity, forcibly to twist the arms at the shoulder joints in order to get them into the position above described. [Since this was written I have learned that in certain American tribes it is the custom to dress the corpse with a coat turned back to front. This seems to suggest that the curious procedure just described may have been dictated by the same underlying idea, whatever it may be.] In the cranium of this case the remains of the desiccated brain were still present, and although there was a quantity of brownish powder along with it, the evidence was not sufficiently definite to say whether or not any foreign material had been introduced into the cranial cavity. In the case of the other three bodies, as I have already mentioned, there was no evidence, apart from the excellent state of preservation, to suggest what measures had been taken to hinder the process of decomposition.

In his account of the obsequies of the Aztec kings, Bancroft (3. Vol. II., p. 603) tells us that "the body was washed with aromatic water, extracted chiefly from trefoil,

and occasionally a process of embalming was resorted to. The bowels were taken out and replaced by aromatic substances." "The art was an ancient one, however, dating from the Toltecs as usual, yet generally known and practised throughout the whole country" (p. 604). He then proceeds to describe "a curious mode of preserving bodies used by the lord of Chalco," which consisted of desiccation; and adds a singularly interesting reference to libations, not only curiously reminiscent of the ancient Egyptian practice, but also described in language which might be regarded as a paraphrase of the Pyramid text expounded by Blackman (5). "Water was then poured upon its [the mummy's] head with these words: 'this is the water which thou usedst in this world'—Brasseur de Bourbourg uses the expression 'C'est cette eau que tu as reçue en venant au monde'" (Bancroft, 3, Vol. II., p. 604).

It is altogether inconceivable that such a curious practice, embodying so remarkable an idea, could by chance have been invented independently in Egypt and in America. This can be no mere coincidence, but proof of the most definite kind of the derivation of these Toltec and Aztec ideas from Egypt.

Bancroft further describes (3, p. 604 *et seq.*) a whole series of other ritual observances, many of which find close parallels in the scenes depicted in the royal Egyptian tombs of the New Empire.

I have already referred to Tylor's case (102) of the adoption *in toto* by the Aztecs of the Japanese Buddhist's story of the soul's wanderings in the spirit-land. In the case recorded by Bancroft almost the same story is reproduced, but with the characteristic Egyptian additions relating to parts of the way guarded by a gigantic snake and an alligator respectively [in the Egyptian ritual it is

of course the Crocodile; see Budge, "The Egyptian Heaven and Hell," Vol. I, p. 159]. This is a most remarkable example of syncretism between the Egyptian ritual of the New Empire with Buddhist practices on the distant shores of America.

As the connecting link between the Old and New World, it may be noted that in Oceania "everywhere is the belief that the soul after death must undertake a journey, beset with various perils, to the abode of departed spirits, which is usually represented as lying towards the west" (61, p. 138).

Reutter (63) gives a summary of information relating to the practice of embalming in the New World and particularly amongst the Incas. The custom of preserving the body was not general in every case, for amongst certain peoples only the bodies of kings and chiefs were embalmed. The Indian tribes of Virginia, of North Carolina, the Congarees of South Carolina, the Indians of the North-West Coast, of Central America and those of Florida practised this custom as well as the Incas. In Florida the body was dried before a big fire, then it was clothed in rich materials and afterwards it was placed in a special niche in a cave where the relatives and friends used to come on special days and converse with the deceased. According to Beverley (1722) the tribes of Virginia practised embalming in the following way:—The skin was incised from the head to the feet and the viscera as well as the soft parts of the body were removed. To prevent the skin from drying up and becoming brittle oil and other fatty materials were applied to it. In Kentucky when the body had been dried and filled with fine sand it was wrapped in skins or in matting and buried either in a cave or in a hut. In Colombia the inhabitants of Darien used to remove the viscera and fill the body cavity with

resin, afterwards they smoked the body and preserved it in their houses reposing either in a hammock or in a wooden coffin. The Muisca, the Aleutians, the inhabitants of Yucatan and Chiapa also embalmed the bodies of their kings, of their chiefs, and of their priests by methods similar to those just described, with modifications varying from tribe to tribe. Reutter acknowledges as the source of most of his information the memoirs of Bauwenns, entitled "Inhumation et Cremation," and Parcelly, "Etude Historique et Critique des Embaumements"; but most of it has clearly been obtained from Yarrow's great monograph (106). Alone amongst the people of the New World who practised embalming the Incas employed it not only for their kings, chiefs and priests, but also for the population in general. These people were not confined to Peru, but dwelt also in Bolivia, in Equador, as well as in a part of Chili and of the Argentine. Mummified bodies were placed in monuments called Chullpas. According to De Morcoy these Chullpas were constructed of unbaked brick and were sometimes built in the form of a truncated pyramid, twenty to thirty feet high, in other cases simple mausolea of a simple monolith. The burial chamber inside them was square and as many as a dozen mummies might be buried in a single one. The bodies were sharply flexed and were placed in a sitting position. An interesting and curious fact about these mummies, or at any rate those from Upper Peru, was that all of them presented on the forehead or on the occiput a circle composed of small holes through the wall of the cranium, which had probably been used for evacuating the brain and for the introduction of preservative substances.

Yarrow (106) refers to the fact that the Indians of the North-West coast and the Aleutian Islands also embalm their dead. This, like the practice of tattooing (Buckland,

10), serves to map out the possible alternative northern route taken by the spread of culture from Asia to America (*vide supra* the account of Aino embalming; also *Map II.*).

In his account of the Araucanos of Southern Chile (*Journ. Roy. Anthr. Inst.*, Vol. 39, 1909, p. 364) Latham describes how, when a person of importance dies of disease, these people believe that some one must have poisoned him. They "open the side of the deceased" and extract the gall-bladder, so as to obtain from the bile contained in it some clue as to the guilty person. "The corpse is then hung in a wicker frame and under it a fire is kept smouldering till such time as the perpetrator be found and punished."

This confused jumble of practices suggestive of a blending of the influences of Egyptian embalming and Babylonian hepatoscopy is also obviously linked to the customs of Oceania and Indonesia.

Scattered in certain protected localities along the whole extent of the great "heliolithic" track the ancient Egyptian [also Chaldean and Indian] practice of burial in large urns or jars occurs. In America also it is found; but, according to Yarrow, it is restricted to certain people of New Mexico and California, although similar urns have been found in Nicaragua.

After the coming of the first great "heliolithic" wave, Asiatic civilization did not cease to influence America.

There are innumerable signs of the later effects of both Western and Eastern Asiatic developments. For instance, there is the coming of the practice of cremation. The fact that such burial customs are spread sporadically in the islands of the Pacific suggests that the custom may have been carried to America by the same route as the main stream of the "heliolithic" cult; but against this is the evidence that cremation was practised especially on

the Pacific slope of the Rocky Mountains, and in Mexico rather than in Peru. It seems more probable that the main stream of the later wave of culture, of which cremation is the most distinctive practice, took the northern route skirting the eastern Asiatic littoral and then following the line of the Aleutian Islands.

In the account of the method of mummification adopted by the Virginian Indians (*supra*) it was seen that the whole skin was removed and afterwards fitted on to the skeleton again. Great care and skill had to be used to prevent the skin shrinking. Apparently the difficulties of this procedure led certain Indian tribes to give up the attempt to prevent the skin shrinking. Thus the Jivaro Indians of Ecuador, as well as certain tribes in the western Amazon area, make a practice of preserving the head only, and, after removing the skull, allowing the softer tissues to shrink to a size not much bigger than a cricket ball (44; 52, p. 252, and 61, p. 288).

According to Page (52), who has described one of the two Jivaro specimens now in the Manchester Museum, desiccation by heat was the method of preservation. He adds, "'Momea' and 'Chancha' are the names commonly given to such specimens by the natives." Surely the former must be a Spanish importation!

A comparison of this variety in the methods of preserving the body in America with the series of similar practices which I have been following from the African shore, makes it abundantly plain that there can be no doubt as to the source of the American inspiration to do such extraordinary things. The remarkable burial ritual and all the associated procedures afford strong corroborative evidence.

But the proof of the influence of the civilizations of the Old World on pre-Columbian America does not

depend upon the evidence of one set of practices, however complex, bizarre and distinctive they may be.

The positive demonstration that I have endeavoured to build up in this communication depends upon the fact that the whole of the complex structure of the "heliolithic" culture, which was slowly built up in Egypt during the course of the thirty centuries before 900 B.C., spread to the east, acquiring on its way accretions from the civilizations of the Mediterranean, Western Asia, Eastern Africa, India, Eastern Asia and Indonesia and Oceania, until it reached America. Like a potent ferment it gradually began to leaven the vast and widespread aboriginal culture of the Americas.

The rude megalithic architecture of America bears obvious evidences of the same inspiration which prompted that of the Old World ; and so far as the more sumptuous edifices are concerned the primary stimulus of Egyptian ideas, profoundly modified by Babylonian, and to a less extent Indian and Eastern Asiatic, influences is indubitable. Comparison of the truncated pyramids of America, of the Pacific, Eastern Asia and Indonesia with those of ancient Chaldea, affords quite definite corroboration of these views. It would be idle to pretend that so complex a design and so strange a symbolism as the combination of the sun's disc with the serpent and the greatly expanded wings of a hawk, carved upon the lintel of the door of a temple of the sun, could possibly have developed independently in Ancient Egypt and in Mexico (see especially Bancroft, 3, Vol. IV., p. 351).

But it is not merely the designs of the buildings and their association with the practice of mummification (and later, in Mexico, with cremation), but the nature of the cult of the temples and all the traditions associated with them that add further corroboration. Thus, for example,

Wake (103, p. 383), describing the geographical distribution of serpent-worship (the intimate bond of which with sun-worship and in fact the whole "heliolithic" cult was forged in Egypt, as I have already explained), writes:— "Quetzalcoatl, the divine benefactor of the Mexicans, was an incarnation of the serpent-sun Tonacatlcoatl, who thus became the great father, as the female serpent Cihua-coatl was the great mother, of the human race." "The solar character of the serpent-god appears to be placed beyond all doubt . . . The kings and priests of ancient peoples claimed this divine origin, and 'children of the sun' was the title of the members of the sacred caste. When the actual ancestral character of the deity is hidden he is regarded as 'the father of his people' and their divine benefactor. He is the introducer of agriculture, the inventor of arts and sciences, and the civilizer of mankind."

Writing of the Maya empire, Bancroft (3, Vol. V., p. 233) says:—"The Plumed Serpent, known in different tongues as Quetzalcoatl, Gucumatz, and Cukulcan, was the being who traditionally founded the new order of things."

Even the most trivial features of the "heliolithic" culture-complex make their appearance in America. Thus, for example, Harrison tells us that:—

"The artificial enlargement of the lobe [of the ear] appears originally to have been adopted in India for the purpose of receiving a solar disc" (29, p. 193).

"The early Spanish historian mentioned that an elaborate religious ceremony took place in the temple of the Sun at Cuzco, on the occasion of boring the ears of the young Peruvian nobles" (p. 196).

"The practice of enlarging the ear lobes was connected with Sun-worship" (p. 198).

So also in the case of circumcision, tattooing, and almost every one of the curious customs I have enumerated in the foregoing account. Then, again, all the characteristic stories of the creation, the deluge, the petrification of human beings and of spirits dwelling in rocks, and of the origin of the chosen people from an incestuous union make their appearance in Mexico, Peru and elsewhere.

The peculiar Swastika symbol, associated with the "heliolithic" cult by pure chance in the place of its origin, which the people of Timor, in Indonesia, regard as the ancient emblem of fire, the Son of the Sun, also appears in America.

Even so bizarre a practice as the artificial deformation of the head (48, pp. 515 to 519), which seems to have originated in Armenia, became added to the repertoire of the fantastic collection of tricks of the "heliolithic" wanderers, and was adopted sporadically by numerous isolated groups of people along the great migration route. For some reason this strange idea "caught on" in America to a greater extent than elsewhere and spread far and wide throughout the greater part of the continent.

Many other curious customs might be cited as straws that indicate clearly which way the stream of culture has flowed. For instance Keane (42, p. 264) states that "like the Burmese the Nicobarese place a piece of money in the mouth of a corpse before burial to help it in the other world"; and Hutchinson (38, p. 448) supplies the link across the Pacific:—"Men, women and children [in ancient Peru] had frequently a bit of copper between the teeth, like the obolus which the pagan Romans used to place in the mouth to pay ferry to the boatman Charon for passage across the Styx."

This reference to Charon reminds us also of the wide-

spread custom, apparently originating in Egypt and spread far and wide, right out into the Pacific and America, of the association of a boat with the funerary ritual, to ferry the mummy to the west.

Certain distinctive aspects of phallism in America might also be mentioned as evidence of the influence of Old World practices.

In the appendix (part 1) to his "Conquest of Mexico," Prescott (59) summarises fully and fairly the large and highly suggestive mass of evidence available at the time when he wrote in favour of the view that the pre-Columbian civilization of Mexico and Peru had been inspired from Asia. In view of the apparent conclusiveness of his statement of the evidence it becomes a matter of some interest and importance to enquire into the reasons which, in the face of the apparently overwhelming testimony of the facts he has summarised, restrained him from adopting the obvious conclusion to which his whole argument points.

Referring to the numerous islands of the Pacific as one means of access of population to America, Prescott quotes Cook's voyages to illustrate how easily the Polynesians travelled from island to island hundreds of miles apart, and adds, "it would be strange if these wandering barks should not sometimes have been intercepted by the great continent, which stretches across the globe, in unbroken continuity, almost from pole to pole.

"Whence did the refinement of these more polished races [of America] come? Was it only a higher development of the same Indian character, which we see, in the more northern latitudes, defying every attempt at permanent civilization? Was it engrafted on a race of higher order in the scale originally, but self-instructed, working its way upward by its own powers? Was it, in

short, an indigenous civilization? or was it borrowed, in some degree, from the nations of the Eastern world? If indigenous, how are we to explain the singular coincidence with the East in institutions and opinions? If Oriental, how shall we account for the great dissimilarity in language, and for the ignorance of some of the most simple and useful arts, which, once known, it would seem scarcely possible should have been forgotten? This is the riddle of the Sphinx, which no *Œdipus* has yet had the ingenuity to solve."

In the light of the facts brought together in the present memoir, it requires no *Œdipus* to answer the riddle. For the only two objections which Prescott raises in opposition to the great mass of evidence he cites in favour of the derivation of American civilization from the Old World can easily be disposed of. Rivers has completely disposed of one by his demonstration of the fact that people—moreover those on the direct route across the Pacific to America—do actually "forget simple and useful arts" (65). The other objection is equally easily disposed of, when it is remembered that it requires only a few people of higher culture to leaven a large mass of lower culture with the elements of a higher civilization (see also on this point, Rivers, 68). Moreover, if language is made a test, the affinities of the various American tribes one with the other would have to be denied. Thus, the language difficulty cuts both ways. But when we have disposed of his objections, the whole of his admirable summary then becomes valid as an argument in favour of the derivation of American culture from Asia across the Pacific.

Since then it has become the fashion on the part of most ethnologists either contemptuously to put aside the probability or even the possibility of the derivation of

American civilization from the Old World (characteristic examples of this attitude will be found in Fewkes' address, 18, and Keane's text-book, 41). On the other side the discussion has been seriously compromised from time to time by a wholly uncritical and often recklessly inexact use of the evidence in support of the reality of the contact, which has to some extent prejudiced the serious discussion of the problem. Perhaps the least objectionable of such unfortunate attempts are Macmillan Brown's (7) and Enoch's books (16). The former has been led astray by grotesque errors in chronology and the failure to realize that useful arts can be lost. Enoch, on the other hand, has collected a large series of interesting but incompatible statements, and has made no serious attempt to sift or assimilate them.

But from time to time serious students, proceeding with the caution befitting the discussion of so difficult a problem, have definitely expressed their adherence to the view that elements of culture did spread across, or around, the Pacific from Asia to America (8; 9; 10; 15; 20; 21; 29; 30; 38; 48; 49; 50; 51; 60; 73; 102; 103 and 105). Among modern demonstrations I would especially call attention to the evidence collected by Dall (73, p. 395), Cyrus Thomas (73, p. 396), Tylor (102) and Zelia Nuttall (49 and 50), and of the older literature the remarkable statement of Ellis (15, p. 117). [In Mrs. Nuttall's monograph (49) there is a great deal, especially in the introductory part, to which serious objection must be taken: but in spite of the strong bias in favour of "psychological explanation" with which she started, eventually she was compelled to admit the force of the evidence for the spread of culture.]

For detailed statements concerning the discussions of this problem in the past the reader is referred to

Bancroft's excellent summary (3), which also supplies a wonderfully rich storehouse of facts and traditions wholly corroborative of the conclusions at which I have arrived in the present memoir.

I find it difficult to conceive how there could ever have been any doubt about the matter on the part of anyone who knows his "Bancroft."

It will naturally be asked, if the case in proof of the actual diffusion of culture from Asia to America is so overwhelmingly convincing, on what grounds is assent refused? One school (of which the most characteristic utterance that I know of is Fewkes' presidential address, 18) refuses to discuss the evidence: with pontifical solemnity it lays down the dogma of independent evolution as an infallible principle which it is almost sacrilege to question. I can best illustrate the methods of the other school of reactionaries by a sample of its dialectic.

No single incident in the discussion of the origin of American civilization has given rise to greater consternation in the ranks of the "orthodox" ethnologists than Tylor's statement (102):—

"The conception of weighing in a spiritual balance in the judgment of the dead, which makes its earliest appearance in the Egyptian religion, was traced thence into a series of variants, serving to draw lines of intercourse through the Vedic and Zoroastrian religions, extending from Eastern Buddhism to Western Christendom. The associated doctrine of the Bridge of the Dead, which separates the good, who pass over, from the wicked, who fall into the abyss, appears first in ancient Persian religion, reaching in like manner to the extremities of Asia and Europe. By these mythical beliefs historical ties are practically constituted, connecting the great religions of the world, and serving as lines along which their inter-

dependence is to be followed out. Evidence of the same kind was brought forward in support of the theory, not sufficiently recognised by writers on culture history, of the Asiatic influences under which the pre-Columbian culture of America took shape. In the religion of old Mexico four great scenes in the journey of the soul in the land of the dead are mentioned by early Spanish writers after the conquest, and are depicted in a group in the Aztec picture-writing known as the Vatican Codex. The four scenes are, first, the crossing of the river; second, the fearful passage of the soul between the two mountains which clash together; third, the soul's climbing up the mountain set with sharp obsidian knives; fourth, the dangers of the wind carrying such knives on its blast. The Mexican pictures of these four scenes were compared with more or less closely corresponding pictures representing scenes from the Buddhist hells or purgatories as depicted on Japanese temple scrolls. Here, first, the river of death is shown, where the souls wade across; second, the souls have to pass between two huge iron mountains, which are pushed together by two demons; third, the guilty souls climb the mountain of knives, whose blades cut their hands and feet; fourth, fierce blasts of wind drive against their lacerated forms, the blades of knives flying through the air. It was argued that the appearance of analogues so close and complex of Buddhist ideas in Mexico constituted a correspondence of so high an order as to preclude any explanation except direct transmission from one religion to another. The writer, referring also to Humboldt's argument from the calendars and mythic catastrophes in Mexico and Asia, and to the correspondence in Bronze Age work and in games in both regions, expressed the opinion that on these cumulative proofs anthropologists might well feel justified in

treating the nations of America as having reached their level of culture under Asiatic influence."

One might have imagined that such an instance, especially when backed with the authority¹⁸ of our greatest anthropologist, who certainly has no bias in favour of the views I am promulgating, would have carried conviction to the mind of anyone willing to be convinced by precise evidence. But not to Mr. Keane! In endeavouring to whittle down the significance of this crucial case, he incidentally illustrates the lengths of unreason to which this school of ethnologists will push their argument, when driven to formulate a *reductio ad absurdum* without realizing the magnitude of the absurdity their blind devotion to a catch-word impels them to perpetrate.

In Keane's "Ethnology" (41, pp. 217-219) the following passages are found:—

"It is further to be noticed that religious ideas, like social usages, are easily transmitted from tribe to tribe, from race to race. [Most of my critics base their opposition on a denial of these very assumptions!] Hence resemblances in this order, where they arise, must rank very low as ethnical tests. If not the product of a common cerebral structure, they can prove little beyond social contact in remote or later times. A case in point is [Tylor's statement, which I have just quoted].

"The parallelism is complete; but the range of thought is extremely limited—nothing but mountains and knives, beside the river of death common to Egyptians, Greeks, and all peoples endowed with a little imagination." "Hence Prof. E. B. Tylor, who calls attention to the points of resemblance, builds far too much on them when he adduces them as convincing evidence of pre-Columbian culture in America taking shape under Asiatic influences.

¹⁸ For the whole driving force of the so-called "psychological" ethnologists is really a reverence for authority and a meaningless creed.

In the same place he refers to Humboldt's argument based on the similarity of calendars and of mythical catastrophes. But the 'mythical catastrophes,' floods and the like, have long been discounted, while the Mexican calendar, despite the authority of Humboldt's name, presents no resemblance whatsoever to those of the 'Tibetan and Tartar tribes,' or to any other of the Asiatic calendars with which it has been compared. 'There is absolutely no similarity between the Tibetan calendar and the primitive form of the American,' which, 'was not intended as a year-count, but as a ritual and formulary,' and whose signs 'had nothing to do with the signs of the zodiac, as had all those of the Tibetan and Tartar calendars' (D. G. Brinton, 'On various supposed Relations between the American and Asian races,' from *Memoirs of the International Congress of Anthropology*, Chicago, p. 148). Regarding all such analogies as may exist 'between the culture and customs of Mexico and those of China, Cambodia, Assyria, Chaldea, and Asia Minor,' Dr. Brinton asks pertinently, 'Are we, therefore, to transport all these ancient peoples, or representatives of them, into Mexico?' (*ib.* p. 147). So Lefevre, who regards as 'quite chimerical' the attempts made to trace such resemblances to the Old World. 'If there are coincidences, they are fortuitous, or they result from evolution, which leads all the human group through the same stages and by the same steps' ('Race and Language,' p. 185).

"Many far more inexplicable coincidences than any of those here referred to occur in different regions, where not even contact can be suspected. Such is the strange custom of *Couvade*, which is found to prevail among peoples so widely separated as the Basques and Guiana Indians, who could never have either directly or indirectly in any way influenced each other" (34).

It is surely unnecessary to comment at length upon this quibbling, which is a fair sample of the kind of self-destructive criticism one meets in ethnological discussions nowadays. Talking of the "limitation of the range of thought" when out of the unlimited possibilities for its unhampered activities the human mind hit upon four episodes of such a fantastic nature, Keane taxes the credulity of his readers altogether too much when he solemnly tries to persuade them that such ideas are the most natural things in the world for mankind to imagine!

Surely it would have been better tactics frankly to admit the identity of origin, and then, following the example of Hough (35), minimize its importance by indicating the variety of possible ways by which Asiatic influence may have influenced America sporadically in comparatively recent times.

But instead of this, Keane insisted upon pushing his refusal to admit the most obvious inferences to the extreme limit and invoked the practice of *Couvade* as the *coup de grâce* to the views he was criticizing. But it was singularly unfortunate for his argument that he selected *Couvade*. His dogmatic assertion that the two peoples he selected are "so widely separated" that they could "never have either directly or indirectly in any way influenced one another" is entirely controverted by the fact that, although *Couvade* is, or was, a wide-spread custom, all the places where it occurred are either within the main route of the great "heliolithic culture-wave" or so near as easily to be within its sphere of influence. Thus it is recorded among the Basques,¹⁰ in Africa, India, the Nicobar Islands, Borneo, China, Peru, Mexico, Central California, Brazil and Guiana. Instead of being a "knock-

¹⁰ Recent literature has thrown some doubt upon its occurrence in Western Europe.

out blow" to the view I am maintaining, the geographical distribution of this singularly ludicrous practice is a very welcome addition to the list of peculiar baggage which the "heliolithic" traveller carried with him in his wanderings, and a striking confirmation of the fact that in the spread from its centre of origin this custom must have travelled along the same route as the other practices we are examining.

After the artificialities of Keane and Fewkes, it is a satisfaction to turn back to the writings of the old ethnologists who lived in the days before the so-called "psychological" and "evolutionary explanations" were invented, and were content to accept the obvious interpretation of the known facts.

More than eighty years ago, Ellis (15, p. 117) with remarkable insight explained the relationships of the Polynesians and their wanderings, from Western Asia to America, with a lucidity and definiteness which must excite the enthusiastic admiration of those familiar with the fuller information now available. On p. 119 he cites an interesting series of racial factors, usages and beliefs in substantiation of the cultural link between the Pacific Islands and America.

Quite apart from the mere evidence provided by the arts, customs and beliefs in favour of the transmission of certain of the essential elements of American civilization from the Old World, there is a considerable amount of evidence of another kind, consisting no doubt to a large extent of mere scraps. For instance, there are not only the stories of Chinese and Japanese junks arriving on the American shore and of American traditions of the coming of pale-faced bearded men from the east,²⁰ but

²⁰ It is quite possible this may refer to the relatively modern incursion of Norsemen and other Europeans into America by the North Atlantic.

there is also a certain amount of evidence from the physical characters of the population themselves. It has been raised as an objection by many people that if there had been any considerable emigration of Polynesians into America they would have left a much more definite trace of their coming in the physical characters of the people of America than is supposed the case. But this argument does not necessarily carry very much weight, for the number of such Polynesians who reached America would have been a mere drop in the ocean of the vast aboriginal population of the Americas. Moreover, there is a certain amount of evidence of the presence of people with Polynesian traits in certain parts of the Pacific littoral. Von Humboldt stated the people of Mexico and Peru had much larger beards and moustaches than the rest of the Indians. But there is a more striking instance in substantiation of the reality of this mixture of Pacific people in America which raises the possibility that a certain number of Melanesians, whose physical characters, being more obtrusive by contrast than those of the Polynesians, were more easily detected. In Allen's memoir (2, p. 47) the following statements are found :—

“ Sir Arthur Helps tells us in his ‘ History of Spanish Conquest in America ’ that the Spaniards, when they first visited Darien under Vasco Nunez, found there a race of black men, whom they (gratuitously as it seems to me) supposed to be descended from a cargo of shipwrecked negroes ; this race was living distinct from the other races and at enmity with them,”

and on page 48,

“ Perhaps other black tribes may be discovered upon a more careful enquiry, and if the theory of Crawford be accepted, which represents the inhabitants of Polynesia in Anté-historic times as being a great semi-civilized

nation who had made some progress in agriculture and understood the use of gold and iron, were clothed 'with a fabric made of the fibrous bark of plants which they wove in the loom,' and had several domesticated animals, a new and unexpected light may possibly be thrown upon the origin of primitive American culture. It is certain that massive ruins and remains of pyramidal structures and terraced buildings closely analogous to those of India, Java and Cambodia, as well as to those of Central America, Mexico and Peru, exist in many islands of Polynesia, such as the Ladrone Islands, Tahiti, Fiji, Easter Island and the Sandwich Islands, and the customs of the Polynesians are almost all of them found to exist also amongst the American races."

"Perhaps here, then, we have the 'missing link' between the Old World civilizations and the mysterious civilizations of America."

SUMMARY.

Between 4000 B.C. and 900 B.C. a highly complex culture compounded of a remarkable series of peculiar elements, which were associated the one with the other in Egypt largely by chance, became intimately interwoven to form the curious texture of a cult which Brockwell has labelled "heliolithic," in reference to the fact that it includes sun-worship, the custom of building megalithic monuments, and certain extraordinary beliefs concerning stones. An even more peculiar and distinctive feature, genetically related to the development of megalithic practices and the belief that human beings could dwell in stones, is the custom of mummification.

The earliest known Egyptians (before 4000 B.C.) practised weaving and agriculture, performed the operation of "incision" (the prototype of complete circum-

cision), and probably were sun-worshippers. Long before 3400 B.C. they began to work copper and gold. By 3000 B.C. they had begun the practice of embalming, making rock-cut tombs, stone superstructures and temples. By the mere chance that the capital of the united Kingdom of Egypt happened to be in the centre of serpent-worship (and the curious symbolism associated with it—Sethe, 74), the sun, serpent and Horus-hawk (the older symbol of royalty) became blended in the symbol of sun-worship and as the emblem of the king, who was regarded as the son of the sun-god.

The peculiar beliefs regarding the possibility of animate beings dwelling in stone-statues (and later even in uncarved columns), and of human beings becoming petrified, developed out of the Egyptian practices of the Pyramid Age (circa 2800 B.C.).

By 900 B.C. practically the whole of the complex structure of the "heliolithic" culture had become built up and definitely conventionalized in Egypt, with numerous purely accidental additions from neighbouring countries.

The great migration of the "heliolithic" culture-complex probably began shortly before 800 B.C. [Its influence in the Mediterranean and in Europe, as also in China and Japan, is merely mentioned incidentally in this communication.]

Passing to the east the culture-complex reached the Persian Gulf strongly tainted with the influence of North Syria and Asia Minor, and when it reached the west coast of India and Ceylon, possibly as early as the end of the eighth century B.C., it had been profoundly influenced not only by these Mediterranean, Anatolian and especially Babylonian accretions, but even more profoundly with Eastern African modifications. These Ethiopian influences become more pronounced in Indonesia (no

doubt because in India and the west the disturbances created by other cults have destroyed most of the evidence).

From Indonesia the "heliolithic" culture-complex was carried far out into the Pacific and eventually reached the American coast, where it bore fruit in the development of the great civilizations on the Pacific littoral and isthmus, whence it gradually leavened the bulk of the vast aboriginal population of the Americas.

[When this communication was made to the Society my sole object was to put together the scattered evidence supplied by the practice of mummification, and other customs associated with it, in substantiation of the fact that the influence of ancient Egyptian civilization, or a particular phase of it, had spread to the Far East and America. Since then so much new information has come to light, not only in confirmation of the main thesis, but also defining the dates of a series of cultural waves, that it will soon be possible, not only to sketch out in some detail the routes taken by the series of ancient mariners who spread abroad this peculiarly distinctive civilization, but also to identify the adventurers and determine the dates of their greatest exploits and the motives for most of their enterprises. In collaboration with Mr. J. W. Perry I hope soon to be ready to attempt that task.

I have deliberately refrained from referring to the vexed question of totemism in this communication, although it is obvious that it is closely connected with the "heliolithic" culture. I have used the expression "serpent worship" in several places where perhaps it would have been more correct to refer to the serpent-totem; but so far from weakening, the consideration of totemism will add to the strength and cogency of my argument.

When I assigned (p. 65) a comparatively late date for

the extension of the "heliolithic" culture to the western Mediterranean and beyond I was not aware that Siret (*L'Anthropologie*, T. 20 and 21, 1909-10) had arrived at the same conclusion.]

BIBLIOGRAPHY.*

1. D'ALBERTIS, L. M. "New Guinea." London, 1880, Vol. I.
2. ALLEN, F. A. "The Original Range of the Papuan and Negritto Races." *Journ. Anthropol. Inst.*, Vol. 8, 1878-9, p. 38.
3. BANCROFT, H. H. "The Native Races of the Pacific States of North America." London, 1875.
4. BENT, T. "The Bahrein Islands in the Persian Gulf." *Proc. R. Geograph. Soc.*, 1870, p. 13.
5. BLACKMAN, A. M. "The Significance of Incense and Libations in Funerary and Temple Ritual." *Zeitsch. f. Ägypt. Sprache*, Bd. 50.
6. BREASTED, J. H. "A History of Egypt." London, 1906.
7. BROWN, J. MACMILLAN. "Maori and Polynesian." London, 1907.
8. BUCKLAND, A. W. "The Serpent in Connection with Primitive Metallurgy." *Journ. Anthropol. Inst.*, Vol. 4, 1874-5, p. 60.
9. *Ibid.* "Ethnological Hints afforded by the Stimulants in use among Savages and among the Ancients." *Journ. Anthropol. Inst.*, Vol. 8, 1878-9, p. 239.

* Many other bibliographical references have been added in the text while this memoir was in course of printing.

- 136 ELLIOT SMITH, *Distribution of Mummification*.
10. *Ibid.* "On Tattooing." *Journ. Anthropol. Inst.*, Vol. 17, 1887-8, p. 318.
11. CAPART, J. "Une Rue de Tombeaux." *Brussels*, 1907.
12. CROOKE, W. "Northern India." 1907.
13. *Ibid.* "The Rude Stone Monuments of India," *Proc. Cotteswold Naturalists' Field Club*, Vol. XV., May, 1905, p. 117.
14. DAVIDS, T. W. RHYS. "Buddhist India." London, 1911.
15. ELLIS, W. "Polynesian Researches." Vol. I., London, 1832.
16. ENOCH, C. R. "The Secret of the Pacific." London, 1912.
17. FERGUSON, J. "Rude Stone Monuments in all Countries." London, 1872.
18. FEWKES, J. WALTER. "Great Stone Monuments in History and Geography." Presidential Address delivered before the Anthropological Society of Washington, February 20th, 1912.
19. FLOWER, W. H. "Illustrations of the Mode of preserving the Dead in Darnley Island and in South Australia." *Journ. Anthropol. Inst.*, Vol. 8, 1878-9, p. 389.
20. FOX, A. LANE. "Remarks on Mr. Hodder Westropp's Paper on Cromlechs, with a Map of the World, shewing the Distribution of Megalithic Monuments." *Journ. Ethnol. Soc.*, Vol. 1, 1869, p. 59.
21. *Ibid.* "On Early Modes of Navigation." *Journ. Anthropol. Inst.*, Vol. 4, 1874-5, p. 389.
22. FRAZER, JOHN. "The Aborigines of New South Wales." Sydney, 1892.
23. GARDINER, ALAN H. Article, "Life and Death." *Hastings' Dictionary of Religion and Ethics*, 1915.

24. GLAUMONT, M. "Usages, Moeurs, et Coutumes des Néocalédoniens." *Revue d'ethnologie*, 1888, p. 73—
Summary in Cartailhac's "Matériaux pour l'histoire de l'homme," Vol. 22, 1888, p. 507.
25. HADDON, A. C., and MYERS, C. S. "Reports of the Cambridge Anthropological Expedition to Torres Straits." *Funeral Ceremonies*, Vol. VI., Cambridge, 1908, p. 126.
26. HAIGH (MISS). "Some Account of the Island of Teneriffe." *Trans. Ethnol. Soc.*, New Series, Vol. 7, 1869, p. 112.
27. HAMLYN-HARRIS, R. "Papuan Mummification." *Memoirs of the Queensland Museum*, Vol. I., 27th Nov., 1912.
28. *Ibid.* "Mummification," *loc. cit. supra.*
29. HARRISON, J. PARK. "On the Artificial Enlargement of the Earlobe." *Journ. Anthropol. Inst.*, Vol. 2, 1872-3, p. 190.
30. *Ibid.* "Note on Phœnician Characters from Sumatra." *Journ. Anthropol. Inst.*, Vol. 4, 1874, p. 387.
31. HARTMAN, C. V. "Archæological Researches in Costa Rica." Stockholm, 1901—a Review in *Nature*, March 16th, 1905, p. 462.
32. HASTINGS' *Dictionary of Religion and Ethics.*
33. HERTZ, R. "Contribution à une Étude sur la Représentation Collective de la Mort." *L'Année Sociologique*, 1905-6, p. 48.
34. HODSON, T. C. "Funerary Rites and Eschatological Beliefs of the Assam Hill Tribes." *Third Internat. Congress Hist. Religions*, Oxford, 1908, Vol. 1, p. 58.
35. HOUGH, W. "Oriental Influences in Mexico." *American Anthropologist*, Vol. 2, 1900, p. 66.

- 138 ELLIOT SMITH, *Distribution of Mummification*.
36. *Ibid.* "Culture of the Ancient Pueblos of the Upper Gila River Region, New Mexico and Arizona." *Bulletin* 87, *Smithsonian Institution*, 1914, p. 132.
37. HRDLIČKA, A. "Some Results of Recent Anthropological Exploration in Peru." *Smithsonian Miscellaneous Collections*, Vol. 56, No. 16, 1911.
38. HUTCHINSON, T. J. "Anthropology of Prehistoric Peru." *Journ. Anthropol. Inst.*, Vol. 4, 1874-5, p. 438.
39. JONES, F. WOOD. In *Report on the Archæological Survey of Nubia* for 1907-8, Vol. II., p. 194.
40. JUNKER, H. "Excavations of the Vienna Imperial Academy of Sciences at the Pyramids of Gizah, 1914." *Journ. Egyptian Archæol.*, Vol. I., Oct., 1914, p. 250.
41. KEANE, A. H. "Ethnology." Cambridge, 1896.
42. *Ibid.* "Man, Past and Present." Cambridge, 1900.
43. LORENZ, H. A. "Eenige Maanden onder de Papoea's." 1905, p. 224.
44. LUBBOCK, J. "Notes on the Macas Indians." *Journ. Anthropol. Inst.*, Vol. 3, 1873-4, p. 29.
45. MACE, A. C. "The Early Dynastic Cemeteries of Nagad-Dêr, Part II." 1909.
46. MOLL, HERMANN. "Modern History." Vol. I., Dublin, 1739.
47. MYERS, C. S. "Contributions to Egyptian Anthropology: 'Tatuing.'" *Journ. Anthropol. Inst.*, Vol. XXXIII., 1903, p. 82.
48. NADAILLAC DE. "L'Amérique Préhistorique." Paris, 1883.

49. NUTTALL, ZELIA. "The Fundamental Principles of Old and New World Civilizations," *Archæological and Ethnological Papers of the Peabody Museum, Cambridge, Mass., 1901, p. 602.*
50. *Ibid.* "A curious Survival in Mexico of the Purpura Shell-Fish for Dyeing." *Putnam Anniversary Volume, 1909.*
51. OLDHAM, C. F. "The Sun and the Serpent." London, 1905.
52. PAGE, H. "Post-mortem artificially-contracted Indian Heads." *Journ. Anat. and Phys., Vol. 31, 1897, p. 252.*
53. PARTINGTON, EDGE. "Ethnographical Album of the Pacific Islands." 3rd series, August, 1898, p. 94.
54. PETRIE, W. M. FLINDERS. "Tarkhan." 1913 and 1914.
55. PERROT and CHIPIEZ. "History of Art in Phœnicia." London, 1885.
56. PETTIGREW, T. J. "A History of Egyptian Mummies." London, 1834.
57. PIORRY. Article "Massage," in *Dictionnaire des Sciences Médicales.* 1819.
58. PRESCOTT, W. H. "Conquest of Peru."
59. *Ibid.* "Conquest of Mexico."
60. QUATREFAGES, A. DE. "Hommes Fossiles et Hommes Sauvages." Paris, 1884.
61. READ, C. H., JOYCE, T. A., and EDGE-PARTINGTON, J. "Handbook of the Ethnological Collections" (British Museum), 1910.
62. REISNER, GEORGE A. *Bulletin of the Boston Museum of Fine Arts.* Vol. XII., No. 69, April, 1914, p. 23.

63. REUTTER, L. "De l'embaumement avant et après Jésus-Christ." Paris, 1912.
64. RIVERS, W. H. R. Presidential Address to Section H. *Report Brit. Assoc.*, Portsmouth, 1911, p. 490, or *Nature*, 1911, Vol. LXXXVII., p. 356.
65. *Ibid.* "The Disappearance of Useful Arts." *Report Brit. Assoc.*, 1912, p. 598 [Abstract of a memoir published in *Festsschrift Tillägnad Edvard Westermarck*, Helsingfors, 1912, p. 109].
66. *Ibid.* "Survival in Sociology." *The Sociological Review*, October, 1913, p. 292.
67. *Ibid.* "Massage in Melanesia." *Report of the 17th International Congress of Medicine*, London, August, 1913, Section XXIII., History of Medicine.
68. *Ibid.* "The Contact of Peoples." Essays and Studies presented to William Ridgeway. Cambridge, p. 474.
69. *Ibid.* "The History of Melanesian Society." Cambridge, 1914, Vol. II.
70. *Ibid.* "Is Australian Culture Simple or Complex?" *Report Brit. Assoc.*, 1914; also *Man*, 1914, p. 172.
71. ROTH, W. E. "North Queensland Ethnography, Bulletin No. 9, Burial Ceremonies and Disposal of the Dead." *Records of the Australian Museum*, Sydney, Vol. VI., No. 5, 1907, p. 365.
72. ROSCOE, J. "Further Notes on the Manners and Customs of the Baganda." *Journal of the Anthropological Institute*, Vol. XXXII., 1902, p. 44
[Also his book entitled "The Baganda."]
73. SEMPLE, ELLEN C. "Influences of Geographic Environment on the basis of Ratzel's System of Anthropo-Geography." London, 1911.

74. SETHE, KURT. "Zur altaegyptischen Sage vom Sonnen-
auge das in der Fremde war." *Untersuchungen zur
Gesch. u. Altertumskunde Aeg.*, Bd. V., Heft 3, 1912, p. 10.
75. SMITH, G. ELLIOT. "On the Natural Preservation of the
Brain in the Ancient Egyptians." *Journal of Anatomy
and Physiology*, Vol. XXXVI., pp. 375-380. Two text
figures. 1902.
76. *Ibid.* "The physical characters of the mummy of the
Pharaoh Thothmosis IV." *Annales du Service des
Antiquités de l'Égypte*, 1904, [and in Carter and New-
berry's "Tomb of Thothmosis IV." London, 1908].
77. *Ibid.* "Report on four mummies of the XXI. dynasty."
Ibid., 1904.
78. *Ibid.* "A Contribution to the Study of Mummification in
Egypt." *Mémoires présentés à l'Institut Égyptien*, Tome
V., Fascicule I., 1906, pp. 1-54, 19 plates.
79. *Ibid.* "An Account of the Mummy of a Priestess of Amen."
Annales du Service des Antiquités de l'Égypte, 1906, pp.
1-28, 9 plates.
80. *Ibid.* "Report on the Unrolling of the Mummies of the
Kings Siptah, Seti II., Ramses IV., Ramses V., and
Ramses VI., in the Cairo Museum." *Bulletin de l'Institut
Égyptien*, 5^e Série, T.I. pp. 45 à 67.
81. *Ibid.* "Report on the Unwrapping of the Mummy of
Menephtah." *Annales du Service des Antiquités*, 1907.
82. *Ibid.* "Notes on Mummies." *The Cairo Scientific Journal*,
February, 1908.
83. *Ibid.* "On the Mummies in the Tomb of Amenhotep II."
Bulletin de l'Institut Égyptien, 5^e Série, Tome I., 1908.

84. *Ibid.* Account of the Mummies of Yuua and Thuiu, in Quibell's "Tomb of Yuua and Thuiu." Catalogue Général du Musée du Caire, 1908.
85. *Ibid.* "The History of Mummification in Egypt." *Proc. Royal Philosophical Society of Glasgow*, 1910.
86. *Ibid.* "The Royal Mummies." Catalogue Général des Antiquités Egyptiennes du Musée du Caire, 1912.
87. *Ibid.* "Egyptian Mummies." *Journal of Egyptian Archaeology*, Vol. I., Part III., July, 1914, p. 189.
88. *Ibid.* "Heart and Reins." *Journal of the Manchester Oriental Society*, Vol. I., 1911, p. 41.
89. *Ibid.* "The Earliest Evidence of Attempts at Mummification in Egypt." *Report Brit. Assoc.*, 1912, p. 612.
90. *Ibid.* "The Ancient Egyptians." London and New York, 1911.
91. *Ibid.* "The Influence of Egypt under the Ancient Empire." *Report Brit. Assoc.*, 1911; also *Man*, 1911, p. 176.
92. *Ibid.* "Megalithic Monuments and their Builders." *Report Brit. Assoc.*, 1912, p. 607; also *Man*, 1912, p. 173.
93. *Ibid.* "The Origin of the Dolmen." *Report Brit. Assoc.*, 1913; also *Man*, 1913, p. 193.
94. *Ibid.* "The Evolution of the Rock-cut Tomb and the Dolmen." Essays and Studies presented to William Ridgeway. Cambridge, 1913, p. 493.
95. *Ibid.* "Report on the Physical Characters of the Ancient Egyptians." *Report Brit. Assoc.*, 1914; also *Man*, 1914, p. 172.

96. *Ibid.* "Early Racial Migrations and the Spread of Certain Customs." *Report Brit. Assoc.*, 1914; also *Man*, 1914, p. 173.
 97. *Ibid.* "The Rite of Circumcision." *Journ. Manchester Egy. and Oriental Soc.*, 1913, p. 75.
 98. SMITH, PERCY. "Hawaiki." London, 3rd Edn., 1910.
 99. TALBOT, P. AMAURY. "Some Ibibio Customs and Beliefs." *Journ. African Soc.*, 1914, p. 241.
 100. TAYLOR, MEADOWS. "On Prehistoric Archæology of India." *Journ. Ethnol. Soc.*, New Series, Vol. I., 1868-9, p. 157.
 101. THURSTON, E. "The Madras Presidency," 1913.
 102. TYLOR, E. B. "On the Diffusion of Mythical Beliefs as Evidence in the History of Culture." *Report Brit. Assoc.*, 1894, p. 774.
 103. WAKE, C. S. "Origin of Serpent Worship." *Journ. Anthropol. Inst.*, Vol. 2, 1872-3.
 104. WEEKS, J. H. "Anthropological Notes on the Bangala of the Upper Congo River." *Journ. Roy. Anthropol. Inst.*, Vol. XXXIX., 1909, pp. 450 and 451.
 105. WILSON, THOMAS. "The Swastika." *Report of Smithsonian Institution*, 1896.
 106. YARROW, H. C. "A further Contribution to the Study of the North American Indians." *1st Report, Bureau Amer. Ethnol.*, Washington, 1881.
-

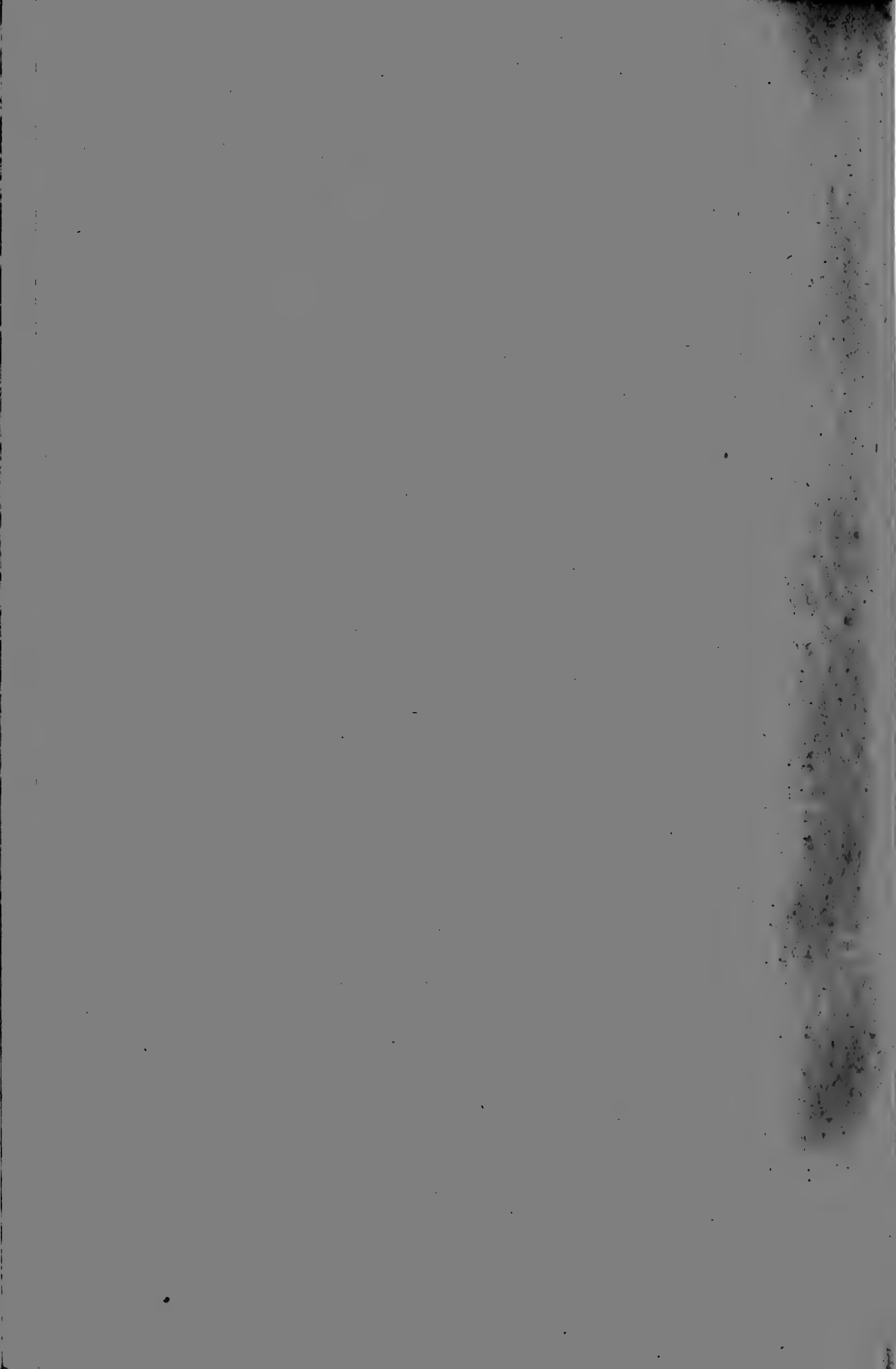

MEMOIRS AND PROCEEDINGS
OF
THE MANCHESTER
LITERARY & PHILOSOPHICAL
SOCIETY, 1914-1915.

CONTENTS.

Memoirs :

- XI. The Place of Science in History. By Professor Julius MacLeod, D.Sc. - - - - - pp. 1-45.
(Special Lecture, May 4th, 1915.)
(Issued separately, August 31st, 1915.)
- XII. John Dalton's Lectures and Lecture Illustrations, Parts I. and II. By Professor W. W. Haldane Gee, B.Sc., M.Sc. Tech.
Part III. By Hubert Frank Coward, D.Sc., and Arthur Harden, D.Sc., Ph.D., F.R.S. *With 8 Pls.* - - - - - pp. 1-66.
(Issued separately, September 3rd, 1915.)
- XIII. Trisecting an Angle. By Professor W. W. Haldane Gee, B.Sc., M.Sc. Tech., and Arthur Adamson, M.Sc. Tech., A.R.C.S. *With 1 Pl. and 24 Text-figs.* - - - - - pp. 1-35.
(Issued separately, October 7th, 1915.)
- Proceedings - - - - - pp. xvii.-xxiv.
- Annual Report of the Council, with Obituary Notices of Mons. E. H. Amagat, For. Mem. R.S.; Mr. Nathaniel Bradley, F.C.S.; Professor James Geikie, D.C.L., F.R.S.; Mr. Thomas Kay, J.P.; Mr. R. B. Longridge, M.I. Mech. E.; Professor Eduard Suess, Ph.D., For. Mem. R.S.; Professor August Weismann, For. Mem. R.S.; and Mr. S. B. Worthington, M. Inst. C.E. - pp. xxv.-xliv.
- Treasurer's Accounts - - - - - pp. xlv.-xlvi.
List of the Council and Members of the Society - - - - - pp. xlviii.-lxiii.
List of the Awards of the Dalton Medal - - - - - pp. lxiii.
List of the Wilde Lectures - - - - - pp. lxiv.-lxv.
List of the Special Lectures - - - - - pp. lxv.
List of the Presidents of the Society - - - - - pp. lxvi.-lxvii.
Title Page and Index - - - - - pp. i.-xii.

MANCHESTER:
36, GEORGE STREET

Price Six Shillings.

January 15th, 1916.

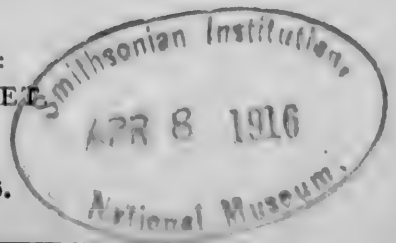

RECENT ADDITIONS TO THE LIBRARY.

Presented.

Axon (Ernest). *See* Nicholson (Francis.)

Batavia.—Koninklijk Magnetisch en Meteorologisch Observatorium te Batavia. Drachen-Freiballon- und Fesselballon-beobachtungen. Von C. Braak. (Verhandelingen No. 3). Batavia, 1915. (*Recd.* 27/ix./15.)

Bolton (Herbert). The Fauna and Stratigraphy of the Kent Coalfield. By Herbert Bolton. London, 1915. (*Recd.* 9/ix./15.)

Cape Town.—Royal Observatory. Cape Astrographic Zones, Vol. II. Co-Ordinates. Zone -42° . Edinburgh, 1914. (*Recd.* 29/ix./15.)

— — — Results of Meridian Observations of Stars made at the Royal Observatory, Cape of Good Hope, ...1905 to 1908. Edinburgh, 1914. (*Recd.* 29/ix./15.)

Harlem.—Musée Teyler. Catalogue de la Bibliothèque. Dressé par J. J. Verwijnen. T.IV. 1904-1912. Harlem, 1915. (*Recd.* 27/ix./15.)

Hubrecht (J.B.). The Solar Rotation in June 1911 from Spectrographic Observations. By J. B. Hubrecht. Cambridge, 1915. (*Recd.* 26/vi./15.)

London.—Royal Observatory, Greenwich. Photographic Magnitudes of Stars brighter than 9^m·0 between Declination $+65^{\circ}$ and Declination $+75^{\circ}$. Edinburgh, 1914. (*Recd.* 29/ix./15.)

Nicholson (Francis) and Axon (Ernest). The Older Nonconformity in Kendal. By Francis Nicholson and Ernest Axon. Kendal, 1915. (*Recd.* 28/ix./15.)

Stockholm.—Académie Royale Suédoise des Sciences. Les Prix Nobel en 1913. Stockholm, 1914. (*Recd.* 14/viii./15.)

Washington.—Bureau of American Ethnology. A Dictionary of the Choctaw Language. By Cyrus Byington. Ed. by J. R. Swanton and H. S. Halbert. (Bulletin No. 46.) Washington, 1915. (*Recd.* 6/ix./15.)

— — — List of Publications of the Bureau of American Ethnology with Index to Authors and Titles. (Bulletin No. 58.) Washington, 1915. (*Recd.* 13/ix./15.)

New Exchange.

Washington.—National Academy of Sciences. Proceedings.

And the usual Exchanges and Periodicals.

XI. The Place of Science in History.

By JULIUS MAC LEOD, D.Sc.,

Professor of Botany in the University of Ghent.

• *Special Lecture, May 4th, 1915.*

(Received for publication May 10th, 1915.)



Only a few years ago the teaching of history in our schools consisted, for the most part, in an endless enumeration of emperors, kings and statesmen, of wars and of battles. We learned by heart the names of the provinces which each sovereign had won or lost after each war, the names of the towns which had been besieged and sacked, and often we were made to learn even incidents of the battlefield, or the means by which victory was gained.

Such teaching accustomed us to think of the map of Europe as a huge chess board, upon which, throughout the ages, kings have played, urged only by their ambition to dispute the heritage of their parents, to divide their possessions to dower their children, and to deprive their subjects of life and goods, whilst they, the subjects themselves, seemed to have no other part to play than to furnish their sovereigns with soldiers and money.

In the same way we learned of many civil struggles, and the contending factions always seemed to us like armies, each army fighting to defend the interests of its leaders.

Such teaching resulted in an incomplete, and in many cases, main inexact idea of history.

But for some years the methods employed in the

August 31st, 1915.

teaching of history have been bettered. In consequence of the progress of historical science, attention was drawn more and more to those who were the subjects of the sovereigns. More and more care was taken to bring home to the pupil that each nation, each association of men, has its history, which does not depend alone on the will of kings, but in large measure on other forces, which go far to make up what we call human nature.

Let us suppose for a moment that we knew, for a given country, for example at the end of the nineteenth century, the legislation, the royal prerogatives, the distribution of wealth amongst the inhabitants, the conditions of trade and labour in town and country, the language, the literature, the works of art, the educational organisation, the general level of education and the religious beliefs of the people. Let us suppose also that we have succeeded, by careful study of all the documentary evidence which has come into our hands, in gaining a complete knowledge of these various sides of the social life in the same country at the end of the fifteenth century. If now we were to make comparison between the two periods, we should establish enormous differences on each of the points mentioned above.

The study of the intermediate periods teaches us that the transition from one period to another did not take place suddenly, but gradually: in other words that historical evolution proceeds step by step. We could study this evolution as a whole, or make division of the subject and consider separately the *line of evolution* of each of the phases of social life.

We learn to consider the state of things in each successive period as a direct consequence of the preceding period, and we try to discover the causes which have given rise to this subsequent state of things.

A comparison of the historical development of several nations teaches us that more or less similar states have been experienced in the same order by each and all. For example, a period of progress is always followed by a period of greatest prosperity and by a period of decline. This applies to the national life as a whole, and to each of its phases. We are thus led to the recognition of certain *rules*, the observance of which constitutes historical development. These have at times been wrongly termed "*historical laws*."

We no longer say that history is made by kings and statesmen; we rather consider each historical figure as a product of the historical period in which he lived,—we go sometimes even too far, and regard kings and statesmen as the instruments by means of which the historical forces of their epoque found expression.

We have tried to sum up in a few words the spirit in which the modern historian endeavours to accomplish his task. We can say further, that he tries to discover the causes of the phenomena and the laws which rule the relation between cause and effect.

As we said above, this modern historical method has influenced the teaching of history in schools. It is no longer enough to enumerate kings and statesmen, wars and battles; it is necessary to give the pupil an idea of the evolution of nations, and of the laws which govern history. Without doubt this is a notable advance.

In reading some modern history books, however, and in conversing with *certain* historians and their pupils, we gather the impression that the use of the modern historical method has very often engendered a kind of fatalistic resignation which brings about a rather deplorable indifference.

War, which has ravaged humanity throughout the

centuries, and which is ever recurring, no longer provokes indignation. The historian is led to the searching of the causes of each war and to the consideration of war as something inevitable. He no longer condemns the statesman who lets slip the dogs of war; he tries to explain how the statesman has succumbed to the influence of the environment in which he lived. . . . He is no longer enthusiastic at the sight of one of our fine Gothic cathedrals, but he coldly explains that the cathedral is the expression of a state of conscience, dominated by a static ideal, whilst our own architects no longer raise edifices destined to endure the centuries, but work so as to fulfil requirements which will cease to exist in a near future . . . When one speaks to certain historians and their pupils of accomplished progress, and of efforts to be made in order further to progress, they answer that every period of progress is followed by a period of decline, and this discouraging answer has in it often something painfully ironical. When one reproaches them with this, often enervating, state of mind, they reply: "Such is truth."

Is it really truth? Are not *these* historians of the actual school carried away by established theories resting on a too fragile basis, which deface truth, and prevent us from seeing it in all its aspects? Yet there is real reason for believing that it is thus.

There is in fact a chapter of history of which historians, properly so called, seem to have lost sight: the history of the evolution of the exact and natural sciences through the centuries.

This evolution has been in progress from earliest times to the present day; new discoveries have been added unceasingly to those already made. Always the horizons of human knowledge have been widened, and new truths have not only exercised an educational in-

fluence on human thought, but they have given birth to innumerable inventions which have augmented our power, and bettered the conditions of our existence. This highway of human progress continues across the revolutions of centuries, like a thread of gold, consolation for the sad spectacle offered by the history of kings and factions.

It is true that the development of science has known periods of decadence and arrest. It is true that scientists have allowed us to see in their work the influence of the environment in which they lived. Doubtless it has chanced that the fruits of long labour have been destroyed,—as example the burning of the library of Alexandria. Doubtless the care of immediate material interests has often intervened, sometimes in favour of progress, but in the majority of cases to delay its march.

True it is that the evolution of exact and natural sciences has been subject to the ordinary rules of historical development, but here we become aware of a superior tireless force, always victorious, and always bringing us back to the path of progress. This creative force constitutes one of the most important factors in the history of humanity.

We would endeavour to emphasise the progressive action of this force and its historical influence by recalling in a few words the work accomplished by certain men of science taken as examples.

Let us first take Archimedes, one of the most ingenious scientists of ancient Greece.

ARCHIMEDES was born at Syracuse in Sicily about 287 B.C. The son of a Pheidias, a learned astronomer, he was well prepared for scientific work, and moreover, he studied at the famous school of Alexandria in Egypt.

Archimedes was a mathematician. To the geometrical science of his time he added many very important propositions, and the geometrical method followed by Euclid was improved by him, and became in his hands almost equivalent to integration, an achievement of modern science. One of his greatest discoveries was the measurement of the circle, a discovery which opened the way for many more calculations.

Moreover, Archimedes did splendid work in physics. His treatise on *floating bodies* contains the general principles of hydrostatics; among other things the discussion of the positions of rest and stability of a solid body floating in a fluid. Several of the propositions contained in that treatise are among the classic instances expounded in modern text-books of physics.¹

Archimedes showed himself brilliantly capable of turning his scientific knowledge to practical account. One of his most ingenious inventions is the so-called *screw of Archimedes*, or *water screw*, which was used through the ages, and is still used to raise water. It was probably devised in Egypt for purposes of irrigation.

On one occasion, Hiero, king of Syracuse, wishing to ascertain whether a crown, which had been made for him, and which purported to be of pure gold, did not contain a proportion of silver, referred the question to Archimedes. Archimedes was puzzled, but after long reflection he devised his test. It occurred to him that if the crown were an alloy of gold and silver, then, since silver is lighter than gold, the volume of the crown would be greater than that of an equal weight of pure gold. The volume of the crown was determined by placing it in a vessel filled with water and measuring the overflow.

¹ He discovered, among other things, the principle in hydrostatics which bears his name.

An equal weight of gold was then placed in the same vessel, and the second overflow likewise measured. It was less than in the case of the crown, and the obvious conclusion was that the crown contained an alloy of some lighter metal. This simple solution of the problem bears the mark of genius, for the reducing of the difficult to terms of the simple is of the essence of genius.

In 214 B.C. the Roman general Marcellus began the siege of Syracuse, both by sea and by land. Archimedes was then about 73 years of age, but he left his peaceful work and turned his extensive scientific knowledge and unsurpassed ability to the arts of war in the defence of his country.

He devised for Hiero engines of war which worked havoc among the Roman ships and protracted the siege for three years. Unfortunately we have very little reliable information on the subject of these inventions. It is said that he constructed a burning mirror which set the Roman ships on fire when they were within a bow shot of the wall, and we are also told of a kind of gun which could throw a heavy stone to a great distance by means of steam pressure. It is clear, however, that the ingenious contrivances of Archimedes were really formidable, and caused widespread terror among the Romans.

In 212 B.C. the city of Syracuse was captured. The town was sacked; many houses were wrecked, treasures of art were looted or destroyed; clouds of smoke darkened for a while the blue Mediterranean sky, many citizens were slaughtered, and among them fell Archimedes at the hand of a Roman soldier. Syracuse now became simply one of the provincial cities of Rome's Empire.

But the science for which Archimedes had lived could not be destroyed. His labours had added to human knowledge and increased human power. Since the fall of Syra-

cuse more than twenty centuries have rolled away. Many battles have been fought and many towns destroyed, but the writings of Archimedes, translated into many languages, have never ceased to be a fountain head of knowledge. Architects, engineers and shipbuilders, all make use of the principles he revealed, and to this day we are still using his water screw, still determining the density of solid bodies by means of the test which he applied to Hiero's crown, and still teaching his lessons on hydrostatics. What he achieved was in itself progress, and by its inspiration it was instrumental to further progress, even in an age when factions were struggling, tyrants oppressing their subjects and kingdoms falling to destruction.

Many inventions and innovations mark the Middle Ages, and the mariner's compass, the Arabic numerals, gunpowder and paper all had their definite influence on human progress. But probably some of these inventions are older than the Middle Ages, and some were not made in Europe. The information, too, which we can collect bearing upon their origin and development is incomplete and often not reliable.

We would, therefore, limit ourselves to a passing mention, and proceed to a second example of a man of science, one drawn from more modern times.

SIMON STEVINUS (STEVIN) was born at Bruges about 1548, and died at The Hague (or at Leiden) about 1620. We note three different aspects of his work: his contributions to the advancement of science, his dissemination of scientific knowledge among the people, and his practical application of scientific theory.

He was a mathematician and a physicist, and among

his discoveries was the so-called hydrostatic paradox.² He further also determined the measure of the pressure of a liquid on any given portion of the side of a vessel. These discoveries are important complements to Archimedes' hydrostatics. He also demonstrated the resolution of forces, which is a consequence of the law of their composition. All these principles are still expounded in the most modern physics text-books.

In 1586 Stevin published in Dutch a pamphlet by which he established the daily use of decimal fractions. He also declared the introduction of a decimal coinage, measures and weights to be only a matter of time.³

One of his most curious inventions was that of the *zeilwagen* (literally, sail-wagon). It was a carriage fitted with sails and propelled by the wind, and was able to attain a speed greater than that of a galloping horse. The *zeilwagen* appealed vividly to the popular imagination, and the memory of it has been preserved by tradition even to our own times.

Simon Stevin learned book-keeping by double entry, probably through studying Italian writers during his stay at Antwerp, where he was for some time commercially employed at the beginning of his career. He realised the advantage of this method, and he had the honour of being the first to recommend its application to public accounts. He practised its use himself in the service of Prince Maurice of Nassau, and recommended it to Sully, a French statesman.

It was during the period in which Simon Stevin lived that Philip II., King of Spain, endeavoured to destroy

² The downward pressure of a liquid contained in a vessel is independent of the quantity of liquid and the shape of the vessel, and depends only on its height and base.

³ In this pamphlet he does not even avoid fractional exponents.

Protestantism in England and the Low Countries. In 1585 the town of Antwerp was taken by Alexander of Parma after a long siege. In 1588 Philip II. sent against his enemies the Spanish fleet known as the *Invincible Armada*. Prince Maurice of Nassau, Prince of Orange, became Stadtholder of the provinces Holland and Zeeland in 1584, after the assassination of his father, William the Silent, and in 1591 he became General-en-Chief of the armies of the united Low Countries.

It is while the storm of a terrible war was raging over his country that we find Simon Stevin making his memorable discoveries in mathematics and physics and popularising useful sciences. But like Archimedes in former times, he was soon led to take an active part in the struggle against the invader. Prince Maurice, who gave him his confidence and asked his advice on many occasions, made him Director of the *Waterstaat*,⁴ and afterwards appointed him Quarter-Master General.

The intervention of Stevin was rich in results. He was, it appears, the first to introduce into military science the defence of fortresses by means of cannon. He is also the inventor of that system of defence which consists in inundation, by means of a system of skillfully placed sluices.

It is chiefly due to this innovation that he contributed so largely to the defeat of the Spaniards, and to the deliverance of the Dutch provinces.

If we reflect for an instant upon the work accomplished by Simon Stevin, whose principal achievements we have already summed up in a few words, we shall no longer hesitate in recognising his historical importance. He indicated and applied the remedy for the disorder which until his time had reigned in the financial affairs of the

⁴ This is the administration of canals, dikes, sluices, etc.

states and towns—a feat alone of sufficient importance to have perpetuated his memory. Every day we make use of the methods of computation which he introduced. Engineers and physicists apply every instant the principle of the decomposition of forces and the principles of hydrostatics which he added to the work of Archimedes.

The system of defence by opening the sluice gates was applied and is still applied in the present war at Termonde, at Antwerp and in the valley of the Yser. If Holland has been for centuries a land renowned for liberty, where so many of the oppressed have found refuge and where so many thinkers have been able freely to express their opinions, it is in part at least due to the fact that Stevin the Fleming made of it an impregnable citadel and a shelter from tyranny. Among the heroes whose memory history has preserved, there are very few of a purer renown or a more beneficial achievement.

Simon Stevin has often been compared with Archimedes, and in fact the careers of these two men offer numerous analogies. Let us combine the two in imagination, and, to form some estimate of their greatness, try to think of all that we should to-day lack if they had never lived.

Among the inventions of modern times, there is perhaps none the influence of which on history has been so great as that of the steam engine. This invention was not made at one stroke ; in other words, the steam engine has, during its long evolution, passed through a series of successive stages, which correspond to as many improvements. In studying this evolution we are led to admire not merely the cleverness of a certain number of ingenious inventions, but also the creative power of purely scientific principles. We will endeavour to demonstrate this in the following short survey.

The steam engine is an apparatus designed to transform heat into mechanical energy, and in which the active medium is steam. The most ancient machine in which the force of expansion of steam was utilised is perhaps the steam cannon invented by Archimedes during the siege of Syracuse (214—212 B.C.), but we only possess very vague indications of its nature.

Almost eighty years later—about 130 B.C.—in the *Pneumatica* of HERO of Alexandria, a description of the *æolipile* was given, a machine which consisted in a hollow sphere revolving on a hollow pillar and provided with two tubes bent in opposite directions and placed at the two opposite extremities of the diameter perpendicular to the axis. The steam, supplied from a boiler, was led through the hollow pivot and escaped through the bent tubes, the sphere turning by the reaction. It was fundamentally, as is easily seen, a primitive turbine.

During the seventeen centuries which followed no notable progress was made. One step forward was however registered by GIOVANNI BAPTISTA DELLA PORTA. In his *Treatise on Pneumatics*, which appeared in 1601, is to be found the description of an apparatus constructed as follows. It consists in a sealed vessel containing water and provided with two tubes. One of them communicates with a boiler in which steam is generated, the other passes into the water and communicates with the exterior. The pressure exercised by the steam on the water makes it spout out of the open tube. The inventor demonstrated that the condensation of the water vapour in the sealed vessel, after the water had been driven out, could be utilised to produce a vacuum to draw up water from a lower level.

In 1615 SALOMON DE CAUS described a fountain similar to that of della Porta but composed only of a

single vessel which served both as boiler and reservoir, the heated water itself being forced upwards.

EDWARD SOMERSET, 2nd Marquis of Worcester, conceived and perhaps constructed a steam apparatus intended to raise water to a higher level. The description of this apparatus is, unfortunately, rather obscure. It probably worked in a manner similar to that of della Porta, but comprised two chambers of displacement, which were emptied alternately by the vapour pressure, in such a way that the other vessel refilled itself automatically with a fresh quantity of water. The use of two vessels acting alternately, was a distinct advance.

A new improvement was introduced by THOMAS SAVERY (1650—1715) and patented in 1698. His machine was much more complicated than all the preceding ones. It consisted in a boiler into which the water, already heated, was driven by means of a steam jet similar to that of Salomon de Caus. The steam generated in the boiler was admitted to a receiver full of water, and expelled the water through a tube after the principle of della Porta. The steam was afterwards condensed in the receiver by the application of cold water to the exterior, and through the agency of the vacuum produced a fresh quantity of water was drawn up through another tube. The receiver is thus filled again, a fresh jet of steam expels the contents, and the action continues. This arrangement was the application of an idea suggested by della Porta. The use of two receivers acting alternately was borrowed from Somerset.

It is clear then that Savery made use of the inventions of his predecessors. What there was really new was the adroit combination of these inventions, the artificial condensation of the vapour, and the addition of tubes and taps connecting the different parts. Now that the steam

engine had taken a really practicable form, it was employed to pump water from mines, and to raise water for the use of towns.

Savery's machine was perfected by J. T. DESAGULIERS, who applied to it the safety-valve, invented by Papin, and who substituted condensation by a jet of cold water in the interior of the receiver for the exterior condensation employed by Savery.

In 1690 DENIS PAPIN conceived the idea of utilising steam pressure to raise a *piston* sliding in a cylinder, the piston afterwards to redescend under the combined influence of the atmospheric pressure and the vacuum produced by the condensation of the steam. Unfortunately his invention was impracticable because he employed the cylinder at the same time as a boiler. Among Papin's inventions one might mention a boiler with *internal heating*. This was the first conception of a system later universally adopted.

In 1705 THOMAS NEWCOMEN and his assistant JOHN CAWLEY gave a practicable form to the cylinder and piston. They fixed the piston to one end of a lever, the other end being provided with a counterpoise. When the piston had reached the bottom of its stroke the admission under the piston of steam provided by a boiler allowed the piston to ascend under the influence of the counterpoise. Then the tap through which the steam had entered, was shut, and a jet of cold water introduced into the cylinder (Savery's method) condensed the steam and produced a vacuum: the piston descended under the influence of atmospheric pressure and worked a *pump*. A fresh jet of steam expelled the water by means of an escape valve, and permitted a fresh stroke of the piston.

⁵ About 1680 DENIS PAPIN applied the safety-valve which he had invented to his *digester*.

The pressure of the steam employed was hardly greater than the pressure of the atmosphere.

About 1711 Newcomen's machine began to be used in coal mines for pumping water. It came into general use about 1725, and remained in use about three quarters of a century.

After Newcomen, fresh improvements of the highest importance were introduced by James Watt. The work of this celebrated inventor deserves a slightly larger consideration.

JAMES WATT was born at Greenock on January 19th, 1736. He learned the trade of a scientific instrument maker in London. In 1756 he tried to continue his trade at Glasgow, but the guilds of the city prevented him, not wishing to recognise a workman who had not served an apprenticeship of the required length of time. The Glasgow college took him under its protection and in 1757 he was established with the title of constructor of mathematical instruments to the University. One day he was required to repair a working model of Newcomen's machine which belonged to the University. This led him to study the steam engine, and was the starting point of a long series of improvements.

Watt was struck by the enormous wastage of heat inherent in the method of condensation invented by Savery and adopted by Newcomen. To obviate this he placed beside the cylinder a second vessel, into which the steam from the cylinder could escape, there to be condensed by the internal or external use of cold water. By this invention of the so-called *condensor* (in 1763), the alternate heating and cooling of the cylinder was avoided, and it became possible to keep the cylinder warm by covering it with a jacket of some bad conductor of heat.

Other improvements followed, and in 1769⁶ Watt took out his first patent.

In 1775 Watt set up in business at Birmingham, where, with his partner, JAMES BOULTON,⁷ whose acquaintance he had made in 1768, he opened a factory for the manufacture of steam engines. The new enterprise was very successful. Boulton occupied himself with the commercial work, leaving to Watt the task of providing new improvements. In the work of Watt we find, still more than in that of his predecessors, the application of purely scientific principles. For example, he studied the physical properties of steam, among other things the relations which exist between its density, pressure and temperature. He is also the inventor of the *indicator*, which shows the relation between the pressure of the steam and its volume during the stroke of the piston in the cylinder. This apparatus was employed by Boulton and Watt to measure the work done by their machines.

For a long time the steam engine had been applied to no other use than the pumping of water. To allow of its application to other uses it was necessary to find some means of transforming the backward and forward movement of the piston into a rotary movement. Watt solved this problem by means of a *crank* and a *flywheel*, the inertia of which ensured continuous movement. Thanks to this arrangement, which is still in universal use, the steam engine can be employed to work any sort of mechanism.

The second patent of Watt dates from 1781. From this moment the steam engine took its modern form. He later introduced the further improvements embodied in his patents of 1782 and 1784.

⁶ In the same year Napoleon was born.

⁷ JAMES BOULTON was born at Birmingham on September 3rd, 1728. He died in the same town on the 18th of August, 1809.

Since that day the work of Watt has been subject to many improvements, but at least one can say that none of the successors of Watt has succeeded in achieving such progress as did he.

Watt was not only an unrivalled mechanic and inventor, but also an eminent man of science. We shall have occasion to speak further of him in this capacity later.

James Watt died at Heathfield on the 19th August, 1819.

The evolution of the steam engine lasted about 180 years, from the publication of della Porta's *Treatise on Pneumatics* in 1601, to the final inventions of James Watt about 1780. During this long period humanity suffered a great transformation. Europe was ravaged by continual wars and incalculable treasure was squandered. History has told us of struggles and conquests, of greatness and decadence, of civil and religious wars, and economic rivalries, and has endeavoured to give us some idea of the historical evolution of the various peoples. But the true historian cannot forget the march of a great idea during this period,—an idea which rose by degrees and took on, more and more, a perfected material form. When James Watt succeeded in first turning his fly-wheel, a solemn hour had struck. What a wonderful book could be written on the influence of the iron giant on the history of humanity, on international relations, on the development of commerce, on the extension of the coal mining industry and on the incalculable social and political consequences of that extension from that hour to this!

But there is more. The historian endeavours to discover the laws of evolution, he tries to discover the causes of historical phenomena. A chapter of history such as that of the development of the steam engine

would open up to him a knowledge of the great force to which we have already made allusion, the progressive march of which may perhaps be checked, but never stopped.

In a history course we should include one wonderful lesson, which should consist of a series of models, reproducing the inventions of Hero, della Porta, de Caus, Somerset, Savery, Papin, Newcomen, Watt, and set in motion one after another before the students, like so many *tableaux vivants* representing the successive phases of the splendid epic, whilst the words of the master should explain the guiding idea.

James Watt was a great conqueror. One day in a Flemish village, I found myself in a factory at about four o'clock in the afternoon, the hour at which the machinery is stopped in order to give an interval of rest to the workers. I entered the engine room and found there the mechanic smoking his pipe. Seeing that I was admiring the silent machine, he pointed to it with his finger and said, "the English invented that." I asked him if he knew the name of the inventor. He replied with a syllable: "Watt!"

James Watt had conquered the mind of that man and of many thousands of others over the whole surface of the earth.

There remain to be considered in a few words two inventions, both applications of the steam engine: the railway and the steamboat.

The first railways were worked by horse traction, and had come into use in connexion with collieries and quarries.

In 1804, a steam locomotive, devised by RICHARD TREVETHICK, was tried on a plate way near Merthyr Tydvil.

In 1811, JOHN BLENKINSOP used an engine to convey coal from his Middleton colliery to Leeds. In 1813, WILLIAM HEDLEY built two locomotives for hauling coal from Wylam Colliery, near Newcastle.

In 1814, an important step was made: an engine, called the *Blucher*, and invented by GEORGE STEPHENSON, drew a train of eight wagons, weighing 30 tons, at a speed of four miles an hour.

In 1821, a railway was built between Stockton and Darlington: this line was over 38 miles in length. It was opened on the 27th of September, 1825. The first train was drawn by one engine, driven by Stephenson, and attained a speed of ten to fifteen miles an hour. On the 10th of October of the same year, a daily coach was brought into use to carry passengers.

The first high-speed locomotive of the modern type was constructed by George and Robert Stephenson. It drew a train 35 miles in 48 minutes on the Liverpool and Manchester railway, which was opened in 1830. By this achievement, a revolution in the methods of travelling had taken place.

On the continent, the first railways were built in the Lowlands: the Brussels and Malines line was opened in 1834, the Amsterdam and Haarlem line in 1835.

It was at Paris, in 1803, that ROBERT FULTON⁸ first succeeded in propelling a boat by steam power. In 1807, a steamship called the *Clermont*, constructed by him in association with ROBERT R. LIVINGSTON and engined by the firm Boulton and Watt, of Birmingham, began to operate on the Hudson between New York and Albany. This was the first steam navigation line.

About the time when the final inventions of James

⁸ Born in 1765, in Little Britain (now Fulton), Pa.

Watt gave to the steam engine its modern form, an ancient science, chemistry, which until then had been hesitating and wrapped in mystery, suffered a profound change, and became an exact science. Amongst the scholars who have contributed to bring about this transformation it is only fitting to name Lavoisier in the first rank.

ANTOINE LAURENT LAVOISIER was born at Paris, on August 26th, 1743, and was executed on the *Place de la Revolution* on May 8th, 1794. By his general use of the balance for the measurement of chemical phenomena, Lavoisier infused a new spirit into the science of chemistry. In other words he applied the quantitative method to chemistry. He set out from the principle that in every chemical reaction the total weight of all the substances produced is necessarily equal to the total weight of all the substances employed. He supposed, besides, that the heat generated by chemical reactions is without weight, and thus avoided the error made by many of his predecessors. Lavoisier's discoveries are so numerous, that we must limit ourselves to noting some of the more important. He laid down that sulphur and phosphorus increased in weight through *burning*, by absorption of air. After the preparation of oxygen (dephlogisticated air) by PRIESTLEY in 1774, and after having laid down that in these combustions only a part of the air is absorbed, he concluded that *atmospheric air is composed of two substances*, the new air (dephlogisticated air) of Priestley, which is absorbed by phosphorus, sulphur, etc., and non-vital air (azote) which plays no part in the combustion. In a paper which appeared in 1782 he called dephlogisticated air oxygen, that is, *producer of acid*, and he formulated the hypothesis that *acids* are produced by the union of oxygen with some simple body, ordinarily

non-metallic. After having verified the truth of this hypothesis in the case of sulphur, carbon, phosphorus, etc., he set himself the problem of finding out what substance was produced by the combustion of inflammable air (hydrogen). He expected the production of an acid. After long researches in collaboration with LAPLACE, he announced to the Academy on the 25th of June, 1783, that the substance produced by the combustion of hydrogen and oxygen was *water*. This discovery, however, had already been made by CAVENDISH. It is to be regretted that Lavoisier has not done justice to the works of Cavendish and other men of science.⁹

Lavoisier's discoveries, and above all the admirable quantitative method which he inaugurated, opened up for chemistry a new highway of discovery. Chemists in ever greater numbers began to tread this highway, continuing and extending the work of the pioneer, and in the course of the 19th century chemistry underwent unprecedented development.

To understand the historical influence of the creator of modern chemistry, one has only to call to mind the innumerable applications of chemistry, from chemical matches and photography to the chemical industry, properly so-called. This industry furnishes us with innumerable products, the economic importance of which is enormous, because, in an infinite number of cases, they transform products of little value into valuable substances, and furnishes to a crowd of other industries products indispensable to them. Among the many applications of chemistry we need only cite the employment of chemical

⁹ Writing to JOSEPH PRIESTLEY in April, 1783, with reference to some of Priestley's experiments, JAMES WATT suggests the theory that water is composed of dephlogisticated air and phlogiston deprived of part of their latent or elementary heat (*Encyclopædia Britannica*, 11th edition, vol. 28 [1911], p. 417).

manure, which has rendered possible the increasing of the production of cultivated areas to a noteworthy extent. In many countries of Europe this increase is such that the result is the same as if hundreds of thousands of acres had been added to the land previously under cultivation ; this is no exaggeration. Consider only for a moment those conquests which have not been made by the sword.

Modern chemistry has had from the first a notable influence on the progress of other sciences, for example biology and medicine, and at the same time the study of chemistry constitutes one of the best schools for human thought, because it demonstrates to us, by means of innumerable examples, the creative power of ideas. Every chemical product is the material realisation of an idea. One may say that Lavoisier discovered a new world full of inexhaustible riches.

Lavoisier was a man of wide learning, and his activities in the most various spheres is truly astonishing. He drew up reports on the cultivation of various crops, and plans for the establishment of experimental farms. Setting to work himself he established in 1778 a *model farm* in order to demonstrate the advantages of scientific methods of cultivation. He busied himself in bettering social and economic conditions by means of savings banks, insurance societies, workshops, canals. He dealt also with questions of hygiene and was secretary of the commission constituted in 1790 to standardise weights and measures.

In these times of often exaggerated specialisation, one may perhaps be tempted to regret that Lavoisier did not devote all his power to chemistry. But we must not forget that it was this very diversity of occupation which made of Lavoisier the *powerful individuality*, alone capable of accomplishing his splendid work. This work is that of a profound thinker, and the laws of thought

remain the same whatever be their object. Moreover, the power of thought does not attain to its full powers save by the development of its various sides, an end which can only be obtained by its application to widely diverse subjects.

Lavoisier occupied the position of "farmer-general of the public revenues," and this was his misfortune. In November, 1793, Convention ordered the arrest of the "farmers general," and in May, 1794, Lavoisier and twenty-seven others were condemned to death.

The last few years of the 18th century constitute a memorable period in the history of Science. Among the discoveries made at this period we would further cite that of the electric current, often known as the voltaic current after the name of its inventor.

ALESSANDRA VOLTA was born at Como on the 18th of February, 1745, and died in his native town on the 5th of March, 1827.

Volta followed with the greatest interest the researches of GALVANI (1790) on the muscular contractions of frogs under the influence of electricity. After many experiments which lasted from 1791-1799, he invented his celebrated *electric pile*, which consisted in discs of copper and zinc (or other metals) with pieces of cloth between the pairs. On the 20th of March, 1800 (three months before the battle of Marengo), Volta addressed a letter containing a description of this apparatus to Sir Joseph Banks, president of the Royal Society of London. •

Improvements were rapidly added by Volta himself and by others, and numerous researches were carried out with the new instrument. In the same year (1800) NICHOLSON and CARLISLE discovered that the electric current had the power to decompose water into hydrogen

and oxygen. In 1807 DAVY discovered the electrolysis of potash and soda, and thus isolated the metals potassium and sodium. In 1808 Davy produced the electric arc between two poles of carbon. In 1820 CHRISTIAN OERSTED, professor at the University of Copenhagen, discovered the deviation of the magnetic needle under the influence of an electric current. In the same year ARAGO and Davy discovered, independently of one another, the power which an electric current possesses of magnetising iron and steel. In 1824 W. SURGEON, by wrapping a metallic wire round an iron core, discovered that the iron is magnetised as long as the wire is carrying an electric current, and ceases to be magnetised when the current is broken.

The above mere enumeration, which is far from being complete, fills us with admiration and astonishment. Here we see at work once more the all powerful *idea*, the *impulse of progress*, the *true maker of history*. The achievements which we have mentioned are not only discoveries of new truths; we know to-day what creative force these truths carried in them. We know the rich harvest of practical applications to which they have given birth. We need only recall to mind the electric telegraph, electroplating, the application of electricity to chemistry, electric locomotion, the telephone, electric heating, and many more.

All these innovations have their starting point in the discovery of Volta. Superficial minds are sometimes tempted to believe that these discoveries were made at one blow, the result of one happy inspiration. History teaches us that, on the contrary, each of them is the fruit of long studies, and has passed through a long evolution. Let us pause a moment in the consideration of one of these inventions, the electric telegraph.

The idea of employing electricity to telegraph to a distance is a very old one. In 1753 the author of an anonymous letter in *Scott's Magazine* proposes to transmit to a distance the electrical influence of a charged Leyden jar by means of metallic wires. A special wire was to correspond to each letter of the alphabet. The wires were to be charged one after another, and the messages received by observing the movements of little pieces of paper, each bearing a letter, and placed under the extremities of the wires. Later, many other similar ways were proposed, until the discovery of Volta opened up a new prospect.

The first attempt, practically to apply electricity to telegraphy, took place in 1837, eighty-four years after the publication of the letter in *Scott's Magazine*, on the *London and North-Western Railway*. For several years afterwards its use remained almost exclusively limited to railways. The first line opened to the public was established between Paddington and Slough, on the *Great Western Railway*.

In all the preceding examples it has been a question of progress achieved in the domain of inanimate nature. The sciences which busy themselves with the study of living things have had to solve problems much more complicated, and consequently their development has been slower. Apart from their descriptive side, they hardly commenced to make any notable progress until the 19th century, and above all, until after the perfection of the microscope, and the application of modern physics and chemistry.

Amongst the most remarkable discoveries which have been accomplished by the science of biology, we take one example, bacteriology.

The last scientist whose works we wish to recall to mind is Louis Pasteur.

PASTEUR was born at Dôle (Franche Comté) on the 27th of December, 1822, and died at St. Cloud on the 28th of September, 1895. After having completed his studies at the Royal College of Besançon, he obtained in 1840 the degree of *bachelier ès lettres*, and two years later that of bachelor of science. He then went to Paris, where he attended the chemistry course of J. B. A. Dumas at the Sorbonne ; he was nominated laboratory assistant by A. J. Balard. He subsequently became professor of chemistry at Strasbourg and Lille and professor at *l'Ecole normale de Paris*.

At the time when Pasteur commenced his researches no satisfactory explanation of the phenomena of fermentation had been found. By his ingenious experiments Pasteur demonstrated that the chemical transformations which take place in these phenomena are invariably due to the presence and the development of very small organisms called ferments, or, more generally, *microbes*. If all trace of these organisms was excluded, no chemical transformation took place. Brewer's wort remains unchanged for years when the air to which it is exposed is cleared of these small living beings. Under the same conditions the juice of grapes remains as it is, without producing alcohol, milk does not become sour, and the acetic fermentation which produces vinegar does not take place. In other terms, the chemical phenomena of fermentation are essentially correlated with a vital phenomenon.

The economic consequences of this discovery are incalculable. It was the starting point of a real revolution in the numerous industries which depend on the phenomena of fermentation : for example, the production

of wine and beer, by replacing by exact ideas the empiricism which had been up to then the sole guide.

Pasteur's discoveries have besides given birth to a new industry, the industry of the preserving of food-stuffs. Numerous products, which at one time could only be kept for a few days, have now become articles of commerce and are preserved for months and even for years. It is only necessary to enclose them in boxes or glass jars hermetically sealed in such a way as to protect them from the germs of the minute organisms which bring about their decomposition (fermentation). Let us suppose for a moment that we wish to preserve some milk. We then place the milk to be preserved in a bottle, which we close with a cork. We place the sealed bottle in a kettle containing boiling water. After twenty minutes the bottle is taken out again. The milk has been *sterilised (pasteurised)*, that is to say, the germs of decomposition (fermentation) which it might contain have been killed by the heat; the cork prevents the entrance of fresh germs, and the milk remains preserved as long as the bottle remains sealed.

Thus a problem which seemed insoluble is solved by the simplest of means. By this process food-stuffs of all kinds can be preserved, the principle remaining always the same, although the nature of the containing vessels and the details of the operation differ according to the products to be preserved.

When one thinks for a moment of the innumerable boxes (tins, etc.) and bottles of preserved goods in every grocer's shop, things of daily use, one realises the full importance of Pasteur's discovery. One realises even more its importance when one takes into consideration the enormous quantities of products which one can send to day from one country to another, and preserve from

one season to another, things one would be unable to use were it not for the method (sterilisation or pasteurisation) introduced by Pasteur.

But the above only constitutes a part of Pasteur's work. His influence on the progress of the science of medicine was equally great, and was exercised in different lines.

One of the greatest obstacles which at one time hindered the progress of surgery was the mortification of the wound which took place after a surgical operation, and which was often more dangerous than the operation itself. Pasteur's discovery explains this phenomenon. Normally the flesh is protected from contact with the air by the skin. When this is removed the germs which are floating in the air fall into the wound, multiply in the flesh, and set up decomposition (fermentation, mortification). It is obviously impossible to exclude the oxygen of the air from wounds, but it is practicable to protect them from the microbes (*bacteria*, bacils, spirils, etc.) by the use of *antiseptic* substances which hinder their development. It was the English doctor JOSEPH LISTER¹⁰ who applied this principle to surgery. The first substance he employed for this purpose was *carbolic acid*. Lister's invention had the happiest results and brought about a veritable revolution in surgical practice.

In an address which he delivered in Paris on the occasion of the 13th International Medical Congress, Lord Lister declared that his method was in reality a practical application of the scientific discoveries of Pasteur.

We know to-day that, just as each kind of fermentation corresponds to a microbe of a definite species, so a great number of the illnesses of men and animals, the

¹⁰ Joseph Lister was born on the 5th of April, 1827. He died in 1912.

causes of which were at one time completely unknown, are the result of the presence of certain microbes (bacteria, etc.), which multiply in the interior of the body. Again, it is Pasteur to whom we owe this memorable discovery. The first disease which Pasteur studied, in 1865, was a silk-worm epidemic. He succeeded in discovering the cause of this disease and indicating the means of preventing it. In this way he rendered a great service to the silk industry in France. He then studied *chicken cholera*, a disease which was destroying 10% of the poultry in France. Pasteur succeeded in reducing the ravages to 1%. The cattle disease known by the name of *anthrax* was studied in its turn: it was a new triumph for Pasteur, who succeeded in saving millions of oxen and sheep in every country of the world.

On the 14th of November, 1888, the Institut Pasteur, devoted to the treatment of *hydrophobia* (or *rabies*), was opened in Paris. Thousands of men, bitten by maddened animals, and drawn from all parts of the world, were saved and cured in this institute. In many other towns institutes similar to that in Paris were founded.

It is difficult in a concise form to give an idea of the methods conceived by Pasteur for combating of microbial diseases. Only a doctor is capable of making such a summary, and the subject is one incapable of comprehension save by a doctor.

We will content ourselves with recalling that the discoveries of Pasteur and the methods of investigation of which he was the pioneer and which have been followed and perfected by a large number of other scientists, have already allowed of the discovery of the microbes of many diseases; that it has been possible to isolate these microbes, to cultivate them, to study their habits, and to weaken them in such a way as to obtain what is known

as an *attenuated virus*. Such an attenuated virus can be employed to render a man or an animal *immune*, that is to say, to prevent him from contracting the malady, or even as a veritable medicine to cure the malady. Let us add further that it is possible in a great number of cases to prevent certain diseases, for example cholera, from spreading and claiming new victims by destroying the microbes or preventing their dissemination. The new medical science created by Pasteur has already accomplished wonders; it is full of promises for the future.

In the above we have considered Pasteur's work chiefly from the point of view of its practical application. There remains to say a few words of the scientific principle which constitutes its real foundation.

Let us ask ourselves why organic matter, such as broth or milk, decomposes (or ferments) when it is exposed to ordinary air. Are the germs of the microbes which bring about these fermentations always present in the atmosphere? Or are the microbes engendered in the substance which ferments, by what is called *spontaneous generation*, the air only entering in to furnish the oxygen necessary for this generation? Both theories have found defenders, and at the time when Pasteur began his investigations many scientists still believed in the spontaneous generation of microbes. After long researches Pasteur was able to demonstrate that the germs of the microbes were present in the atmosphere and floated in it in the form of *dust*. Whenever this dust was successfully eliminated, fermentation did not take place. Among the numerous experiments by which Pasteur proved this truth, we mention one which it is easy to repeat. In a glass flask we place a certain quantity of a liquid which, under ordinary conditions, decomposes rapidly, for example broth. We boil

this liquid for a few minutes in order to kill the germs which it contains, and *whilst it is still boiling* we close the opening of the flask by means of a stopper of wadding which has previously been passed through a flame in order to kill any germs which might adhere to the outside. Then we allow the liquid to cool. The broth is preserved indefinitely.¹¹ The stopper of wadding serves as a filter. It allows free passage to the gases of the atmosphere but excludes the dust. This experiment can be repeated, all other conditions remaining the same, but a stopper of wadding being used which has been freely exposed to the air for some time and which in consequence is covered with dust, not having been passed through the flame. In this case the germs fall from the stopper into the broth and microbes appear in it, which rapidly bring about the decomposition. From these two experiments we can conclude that microbes, like all other living things, are produced from pre-existing germs, and that the germs float about in the atmosphere. In real nature, therefore, spontaneous generation does not exist. Such then, summed up in a few words, is the important scientific truth demonstrated by Pasteur, which constitutes the corner-stone of his work.

The historian who treats of the development of the economic situation of France during the last forty years, would produce only an incomplete work if he did not take into account the influence of the great *maker of history*, Pasteur. We would remind the historian and the economist that THOMAS HUXLEY has expressed the opinion that the work of Pasteur was sufficient to make up the war indemnity of five milliards which France paid to Germany

¹¹ In the Botanic Gardens in Ghent we have kept a flask prepared in this way by Dr. A. J. J. VANDEVELDE for more than eleven years. In August, 1914, the broth was still intact (fresh).

after the war of 1870-71. No competent judge would find this estimate an exaggerated one.

We have seen the *superior force* at work, the great impulse which through the instrumentality of a few men of science has urged humanity along the path of progress. The few examples which we have treated will certainly have convinced us that this impulse is a historically important factor.

The modern historian tries to discover the different factors which have influenced the evolution of peoples and of humanity considered as a whole, such as the religious and economic factors, the actions of emperors, kings and leaders of parties, the influence of climate, of the boundaries of land and sea, mountains and plains, deserts and forests. He tries to define the character of these different factors, and to discern the laws which govern their action.

These historical factors come before us as unconscious and blind forces to the effects of which man is condemned to submit, without the power of guiding or governing them. We learn to regard personages themselves as in some sort instruments obeying the influence of events or of the environment in which they have lived.

The *great historical impulse*, the superior force of science, comes before us under an entirely different aspect: it is a conquering force, pursuing one invariable aim through the centuries, the *conquest of truth*, and *its* conquests have never been bought with tears. The treasures of truth which it stores up are inexhaustible; no prodigality can diminish the store, because they are purely spiritual. Each conquered truth becomes a creative instrument of new riches. By the diffusion of its treasures and the quickening spectacle of its activity, it improves mankind.

The reader will perhaps be tempted to consider the above as an expression of a *sentimental idealism* which the historian and the economist need not take into account. Does the economist recognise inexhaustible treasures? Has the historian ever spoken to us of conquests accomplished without the sword? And have not men remained the same for centuries? Is not the improvement of man an unrealisable dream?

Nevertheless, we have adhered strictly to the truth, in proof whereof let us examine a little more closely this force which conquers truth.

The eminent men of whom we have made mention were endowed with powerful imaginations, guided by observation and experience, and tempered by the inflexible logic of the mathematical spirit. They endeavoured to give a material form to their ideas. It is only very rarely that their discoveries and their inventions have been due to accident. Almost always a long period of preparatory work has been necessary.

We see, for example, Archimedes acquiring vast knowledge at the school of Alexandria, after having doubtless received lessons from his father, who was a man of science. We find him improving and extending the work of the geometers who had preceded him, and whose work he had studied.

We see James Watt studying and reflecting through long years; we see him indefatigably at work, becoming in turn maker of instruments, geometer, physicist, chemist; we see him preceded by a long series of inventors who had step by step made progress the common work.

Lavoisier was a man of immense erudition, an indefatigable worker. We see Pasteur studying literature, and then acquiring general scientific ideas; finally he studied chemistry, and made in this science remarkable

discoveries. Thus prepared, he commenced the study of microbes, and to this study devoted more than thirty years of his life.

Whatever be the example we choose, the lesson to be drawn from it is always the same. Each definite advance has been realised little by little, by a series of successive steps, and by the indefatigable work of men prepared by serious studies.

The history of the evolution of the natural sciences contains yet other lessons. The discoveries are innumerable which, when they were made, were only a simple statement of new truths, and which later took an immense importance. It is in this spirit that numbers of entomologists have for centuries patiently collected and described innumerable insects; have studied the ways of these little animals, their methods of feeding and their metamorphoses. Led by the desire to discover truth and to gather together collections of these minute forms of life, which are often of a remarkable beauty, they have accomplished a work which might well seem futile. But to-day we recognise more and more the immense services which entomologists have rendered us, and continue to render; it is sufficient to remember the application of entomology to agriculture, and to medicine, especially to the study of certain tropical diseases. And the cryptogamists who have studied and collected a crowd of little plants, completely insignificant in appearance,—have they not created, little by little, a new science, which endeavours to combat the parasitic diseases of cultivated plants, and which bears to-day the most splendid fruits?

A characteristic trait of the conquests accomplished by the great impulse which creates riches and alleviates evils by means of truth, is the complete disproportion existing between the price of the conquests and their

value. All the discoveries of Pasteur hardly cost a few thousands of pounds: they produced hundreds of millions and alleviated many sufferings. The richest parts of the earth, situated in the torrid zone, have until now been poisoned by maladies which render the sojourn of Europeans in these parts painful and dangerous. What do the few thousands of pounds, devoted each year to the study of tropical diseases, signify in comparison with the milliards of which we can to-day foresee the conquest?

The study of the natural sciences teaches us, better than the other sciences, to understand the meaning of the expression *natural law*. A *law of nature* suffers no exceptions. As soon as an exception is proved, it is no longer a law, but a *rule*, which is only applicable in certain circumstances. The two ideas of law and rule are often confused, which gives rise to misunderstandings, and even to mistakes.

When we say, for example, that water consists of one part of hydrogen and eight parts of oxygen, we have enunciated a law, because up to the present no one has been able to prove an exception.

But when we say that the price of a commodity increases with the decrease of the supply or the increase of the demand, and vice-versa, we have not laid down a law, but a rule. Here, for example, is an exception: *the more a book is in demand, the lower becomes the price*. The relations between the price, the supply and the demand are often too complicated to be expressed in a single law applicable in all circumstances. It is probable that many so-called *laws*, often quoted in the sciences of sociology and history, and held to be unquestionable, are really rules.

It is incontestable that in the domain of the natural sciences, similar confusions are very often the case. But

here it is more easy to correct the mistakes committed. It is indeed ordinarily possible to survey a large number of facts, and is in consequence much easier to discover exceptions and to ascertain that an imagined discovery of a law is only that of a rule. Moreover *the active intervention of the experimenter* makes it possible to *verify* whether a so-called law deserves that name.

The study of natural science and its applications teaches us that knowledge of the laws of nature enables man to subdue and overcome nature.

When the naturalist or the doctor has discovered a rule, the effects of which are harmful, he does not content himself with recording the fact with resignation. He endeavours to combat these effects, and very often he succeeds.

One may say, for example, that it is a natural law that cultivated fields should be overrun with weeds. If one contents oneself with the simple observation of the facts, this would seem to be a real law, because it is certainly impossible to discover a cultivated field without weeds. But the active intervention of the experimenter teaches us that it is only a simple rule which is here in question. It is indeed possible to pull up the weeds and thus diminish their ravages. And if one perseveres for some years, working methodically, and preventing the harmful weeds from bearing ripe seeds, one can succeed in suppressing them altogether. This has been done, and the advantages obtained are notably greater than the expense incurred.

But even when one is dealing with the effects of a real law, one can often combat it with success. One of the best examples one could take is the following: it is a natural law that bodies fall in consequence of the force of gravity. But it is possible to construct balloons which

rise instead of falling, and physics teaches us that it is precisely the force of gravity which makes them rise!

The history of the natural and medical sciences is the triumph of utopia. If, five centuries ago, one had predicted that one day there would be steam engines, railways, telegraphs, telephones, and electric lamps, would he not have been considered as a utopian? People would have gone further, he would have been considered mad. Yet all these marvels, and many others, have been realised.

It may be objected perhaps that the progress of which we have spoken has been purely material, and that science is powerless to modify human nature; that man's egoism, his rivalries, jealousies and prejudices, his desire to accumulate wealth, his thirst for power, and the differences of race have stirred up interminable struggles in the past, and that the same will be the case in the future, because men to-day are not better than those in the past.

It may be said that among the examples which we have quoted there are some which show science reduced to impotence by the faults of human nature. For example, why are the methods which allow such advantages to be obtained by the destruction of weeds not universally employed? Are not the obstacles to be found in the spirit of routine and the ignorance of the peasant? If one were to enlighten the peasant would he not draw back before the considerable expense involved, an outlay which would increase the value of the ground he cultivated, but only after a number of years, and in such a way that the profit would be reaped rather by his landlord than by himself? And if one were to point out to the landlord and to the leaseholder that they had an interest in common and that it was only right that each should bear a portion of the burden of the expense, would they not be discouraged by

the thought that their efforts would be rendered vain, as long as their neighbours did not work to the same end, because the cleared fields would be overrun by fresh weeds, the seeds of which would be carried by the wind from the neighbouring neglected fields? If the government, enlightened by men of perception, were to make the clearing of the fields obligatory, and were to employ coercive measures to this end, would not the landlord and the agriculturist resist in the name of their violated liberty, and would they not be encouraged in their resistance by politicians in opposition to the government?

He who reflects on such obstacles, which often bar the way, will be perhaps discouraged; will be inclined to follow the example of the historian who contents himself with stating facts with resignation, without approving or condemning, or making any effort to better the state of things.

But the study of the natural and medical sciences, an acquaintance with their history, and a knowledge of the conquests already accomplished, induces a state of mind which does not allow discouragement to last for long. Let us ask science by what means it is possible to improve men, and beware of expecting an *immediate* and *complete* answer. Let us remember that the way of progress is trodden by successive steps, at the price of long and persevering toil. If we succeed in producing an improvement, however small it may be, let us rejoice in this conquest, and turn again to work, in order to realise another.

Every living being carries within him at the moment of his birth the germs of a great number of *attributes*, of which some may be considered *favourable*, some indifferent and some *harmful*. In the case of every individual some of these *innate* attributes never show themselves; they remain hidden or latent, whilst others develop and

become visible. In other words, each individual only shows us a part of his innate attributes; it is as though the latent potentialities (germs) did not exist. Numerous experiences have taught us that the appearance of these innate attributes depends in a large degree on the conditions of existence. Under certain conditions *this* talent (attribute) becomes visible, and *that* remains latent, whilst under other conditions other talents (attributes) will appear or will remain hidden.

We see, for example, that the leaves of the tree known as the *copper-beach* have a red of reddish brown colour. But this colour only appears under the influence of ordinary light. In shadow the leaves become green, the characteristic colour of the species disappears almost completely (in deep shadow completely).

We all know the large floating leaves of the *water lily*. These leaves only acquire their characteristic appearance when they can float on the surface of the water. If it is too deep for them to reach to the surface, they become thin, transparent, more or less shrivelled: they are unrecognisable and seem to belong to another species. May the water level fall, the floating leaves appear.

The pretty white flower called *Edelweiss*, which adorns the high mountains of the Alps and the Pyrenees, undergoes a profound change when it is cultivated on the plains, where the conditions of existence are different. The pretty shape of the plant disappears and the flowers become greenish.

One of the most remarkable instances of such a change is the following. In certain caves where no ray of light has ever penetrated, there exists a species of Salamander called *Olm*. This animal has no eyes. But when it is exposed to the light (with certain precautions), an incredible transformation is apparent. The eyes appear

and develop little by little, and at the end of a sufficient time they are perfect enough to allow the animal to make out the objects which surround it.

The common *Snapdragon* (*Antirrhinum majus*) bears strange flowers which resemble a mask or a muzzle. But there also exists a variety of snapdragon which has (like many other plants) a star-shaped flower of five petals. If the two varieties are crossed it is possible to obtain *hybrids* which bear flowers of the mask form when well nourished and star-shaped flowers when ill nourished.

The beautiful colours of butterflies, which are characteristic of each species, can be profoundly modified by transferring the caterpillars to plants other than those to which they are accustomed. The colours of butterflies can also be modified by exposing the chrysalis to a temperature differing from the ordinary temperature.

The tropical plant called *Philodendron pertusum* bears large leaves pierced with round holes, which give to this curious plant the name of *pertusum*, which means *perforated*. When this plant is cultivated in a greenhouse sufficiently cold and dry, the holes do not form : the *pertusum* ceases to be *perforated*. In a sufficiently warm and wet greenhouse, however, the holes reappear.

These few examples, chosen from amongst a large number, suffice to show that living things are, at least in a large measure, shaped, formed by external causes. THIS CALLS FOR REFLECTION. We say that the *copper-beach* has red leaves and that the *olm* is blind because we have seen these things from generation to generation in the same conditions, but they are not *necessarily* so (in other words, it is not a *law*, but only a *rule* that they are so).

Man does not escape the common rule. In his bodily as in his spiritual attributes he bears the mark of the external influences which he has suffered. The action of

these influences makes itself felt all through his life, and above all *during his early years*. The differences to be observed between the inhabitants of different countries, which one is tempted to attribute to racial differences, are due in large measure to differences of environment. This is, for example, incontestable in the matter of language. An Italian child brought up in England speaks English *exactly* as an English child, and vice versa.

The above indicates the route we have to follow in order to better mankind. The moral attributes of men, which alone we have to treat here, depend to a certain extent on the physical environment in which they have lived. Between the inhabitants of the plains and the inhabitants of the mountains, the men who live on the coast and those who inhabit the interior, there are certain moral differences which, quite as much as the differences of language, depend alone on the environment. But the moral attributes of a man depend, above all, on the ideas which have been inculcated in him, the habits of thought which he has been made to contract, and, more still on the examples which he has had before him, indeed, speaking generally, on the influence of the men among whom he has lived.

All these things have long been known, but it is useful to recall them from time to time, for they seem very often to be forgotten and their ENORMOUS IMPORTANCE seems to be lost to view. Therefore every moment we hear men of clear intellect speaking of the differences which exist between different peoples, without giving themselves the trouble to discover which traits of character depend upon differences in *innate* attributes, and which traits have been merely *acquired* under the influence of environment.

Very fine books have been written on the art of improving humanity by education, and we have no intention

of writing a fresh book on this subject. We would only observe that in this matter one should not rest on one single principle, or limit oneself to the use of one single means. On the contrary, many means must be employed at one and the same time, each contributing a little to bring us nearer to the desired end.

The teaching of the history of the exact and natural sciences and of their applications, is one of the means which one can employ to improve men, to further the unfolding of their qualities and to stifle their defects.

This history offers us the spectacle of progress achieved by peaceful work. It teaches us how apparently insurmountable difficulties have been vanquished by will and perseverance. It shows us how gigantic works have been accomplished without riches, without power, by the might of thought enriched by knowledge. When it speaks to us of Archimedes and of Simon Stevin, it shows us the man of science playing a part in war, not in any conquering spirit, without any desire for military glory, but merely to repel an invader. And finally it shows us at work the great *superior guiding force*, which is the great impulse to the discovery of truth.

Such instruction should have no recourse to fiction; it is a simple story of realities. It can exercise its influence for good on all spirits: on those which are attracted towards abstract ideas, and on those which hold rather to tangible realities.

The history of natural sciences can be taught in many ways, for example, by means of books and classes, and many a good piece of work of this sort has already been carried out. It is desirable to multiply the number of classes, more diffuse the books and publish new ones.

One can go further. The history of science may be considered as a complement to the teaching of history,

properly so called, for it gives us a knowledge of one of the most important sides of the evolution of humanity. This history can be taught profoundly in the universities; in a more elementary way, if need be by means of well chosen examples, in other schools and even in primary schools.

We have tried to show that the progress of the natural sciences has been in the past a factor of historical importance. We would return once more to this theme and cite one final example.

We have often read and heard it maintained, that the profound changes which have taken place during the nineteenth century in all the countries of Europe have been a consequence of the French revolution and the Napoleonic wars. One cannot deny that these events have had consequences of the highest importance. But this should not make us lose sight of other *historical* events which occurred at the same time, and the importance of which, perhaps, is not sufficiently brought out by the historian. Let us recall some of them. In 1781 the steam engine took its modern form in the workshop of Boulton and Watt. About the same time modern chemistry took its birth in Lavoisier's laboratory. In 1791 Galvani discovered the electric current, and in 1799-1800 Volta constructed the first electric pile. In 1807 the first steamship line was established by Fulton, and in 1814 an improved locomotive was constructed by Stephenson.

During the thirty years which preceded the battle of Waterloo, a new world was created. This world can be summed up in three things; the steam engine, the electric current and chemistry. Without these three things the 19th century would not have become what it has been.

Never has the influence of the natural sciences been

so powerful as at the time in which we are living, and this has given birth to a social need the urgency of which is making itself felt more and more. It is the need of professional instruction addressed to the entire population.

At one time the knowledge which the workman, the artisan and the agriculturalist might possess was relatively limited, and altered but slowly. Between the instruction given in universities and schools and the technical knowledge demanded in the exercise of a trade, there was only a very distant relationship. . . . A considerable number of new industries have sprung into being, for example, the electrical industries, the chemical industries, the industry of food preserving, photography. Almost all the industries of earlier days have been transformed: such for example is the case with the construction of machinery, the manufacture of stuffs, printing, horticulture. Agriculture itself, which for ages has been eminently routine work, has become the object of numerous improvements.

On all sides instances of the applications of scientific ideas become more numerous, and the different industries demand from their workers more and more extensive knowledge. In reading the reviews and treatises published for the use of the blacksmith, the shoemaker, the electrician, the carpenter, the market gardener, the arboriculturist, and many others, one is surprised to find how wide spread and varied are the applied scientific ideas, and what an effort of thought is demanded on the part of the reader. He who has lived far from that actual sphere of social life is indeed overwhelmed to find, for example, what difficult and complicated problems, in relation with chemical manure, milk industry, and other matters, the young agriculturists in certain countries, Holland, for instance, learn to solve.

New needs bring forth new instruments. The

demands of modern industry and agriculture have brought forth more and more extensive professional instruction in all countries. But much remains to be done, and many countries are still backward.

The progress accomplished by the natural sciences and by the mathematics bound up with them, has been in the past a factor of historical importance. By teaching the history of this progress one can turn out better men by means of the good examples placed before their eyes, and by developing their power of thought. Such instruction helps to combat the routine spirit; it constitutes a natural introduction to professional instruction, and can thus help to satisfy a social need of our times.

The dates and names quoted in this paper are given according to the *Encyclopædia Britannica*, 11th edition.

I beg to thank Mr. L. DU GARDE PEACH, M.A., of Manchester University, who kindly translated this lecture into English for me.

XII. John Dalton's Lectures and Lecture Illustrations.

Parts I. and II.

By Prof. W. W. HALDANE GEE, B.Sc., M.Sc.Tech.

(Read May 11th, 1915. Received for publication July 15th, 1915.)

INTRODUCTION.

During last summer some members of a special committee of the Council of the Manchester Literary and Philosophical Society, whilst preparing a catalogue of the apparatus and other property in the House of the Society, had their attention directed to a roll of diagrams in one of the cupboards. Many of these were annotated with the unmistakable handwriting of John Dalton, and there was evidence that they had been made by him and used in his lectures. After further search, the collection reached 150 in number. They related to Mechanics, Physics, Chemistry, Astronomy and Meteorology. Some of the diagrams were exhibited and explained by Mr. R. L. Taylor and myself at the meeting of the Society on October 6th, 1914.

Since many of the diagrams had reference to the Atomic Theory, it was decided to ask Dr. Arthur Harden, who was associated with Sir Henry Roscoe in writing "A New View of the Origin of Dalton's Atomic Theory," to inspect the diagrams. This he did in conjunction with Dr. H. F. Coward and the writer.

The diagrams have been pressed and cleaned. In a few cases the ink has caused such corrosion that it has been necessary to paste thin transparent paper over the

September 3rd, 1915.

crumbling portions and to provide others with a backing of paper. In most cases, however, the sheets are in an excellent state of preservation.

The diagrams have been divided into two groups, those relating to :—

1. Mechanics, Physics, Astronomy and Meteorology.
2. The Atomic Theory.

It was decided to prepare catalogues of these two groups, and to include a description of any of special interest.

In carrying out this task it was found that it would be essential to examine the Dalton Manuscripts in the possession of the Society, especially with the object of finding references to the use of the diagrams. Among the manuscripts and miscellaneous packets of papers, a number of Lecture Notes and Syllabuses of Courses of Lectures were found.

Hitherto the accounts published of the lectures of Dalton have been very incomplete, and few have realized the important position that his lectures have had in his life-work. It is intended later to detail certain of these lectures more fully ; meanwhile, the following summary has been prepared.

Part I.

John Dalton's Lectures.

In 1787, when Dalton was twenty-one years of age, he added to his school duties that of giving lectures. He announced in a printed syllabus¹—a framed copy of which is on exhibition in the Society's rooms—that twelve Lectures on Natural Philosophy would be read at the School at Kendal if a sufficient number of subscribers

¹ This syllabus is reprinted in "John Dalton and the Rise of Modern Chemistry," by Sir H. E. Roscoe, 1895. See p. 43.

were procured. The fee was half-a-guinea for the course, or one shilling per lecture. We have no information relating to the success, or otherwise of this first attempt.

The next syllabus dates four years later, and the charge is reduced for the set of twelve lectures to 5s. This syllabus is reproduced on *Pl. I.* Dalton made it a rule to give a balance-sheet relating to his lectures and the one for these lectures, with its wrong addition, is shown on *Pl. II.* He has also recorded the names of the subscribers and the attendances at his lectures. The list includes 80 names; the attendance at each lecture varied considerably, the average being about 20.

In 1793, Dalton, now 27 years of age, came to Manchester to teach Mathematics and Natural Philosophy at the Manchester Academy, where he remained as tutor for six years.

In a letter to his brother Jonathan, dated "6th month, 13, 1796," he wrote:—

"I have had some thoughts of delivering a course of lectures at Kendal this summer, as far as the apparatus there would admit and what additional might be made for the occasion. About 6 Lectures on Chemistry and 6 on the other branches would be my plan. I imagine you have had none lately. Twenty subscribers at Half a Guinea would be sufficient inducement to commence. Tickets to admit a Gentleman and Lady, or two Ladies; Single Lectures, 1/6. Thou may please to mention it to one or two to see how it is likely to take, and let me know by the end of the month, as I should wish to know before I quit this place. I do not however wish to press the subject; nor to engage myself absolutely."

The lectures were arranged. In a pocket-book giving details of his summer expenses to Kendal he records that

he sold ten 10s. 6d. tickets, one at 5s., and a number of odd tickets bringing in a total sum of £7. 15s. od. His expenses were £1. 6s. od., giving him a profit of £6. 9s. od.

1803-1804.

In 1803 Dalton went to London and on his return to Manchester he wrote to his brother :—

“ I have fallen into business again much as usual, except with regard to private pupils, who have nearly all of them left the study of Mathematics and Natural Philosophy for that of military affairs, for a season at least.² I have not heard from the manager of the Royal Institution yet since I left London; am therefore undetermined on that head.” This last sentence refers to the arrangements respecting a course of lectures (for which he received a fee of 80 guineas) which he commenced at the end of 1803 and concluded on the 23rd January, 1804.

The Syllabuses of the lectures issued by the Royal Institution show that they covered a wide range and included Mechanics, Electricity, Magnetism, Optics, Astronomy, Use of the Globes, Sound, Heat, Constitution of Mixed Gases, and Meteorology. A search for notes relating to these lectures has not been successful, the only details available are from his letters.³ He tells us that it required great labour to get acquainted with the apparatus at the Royal Institution and to draw up the order of experiments and repeat them in the intervals between the lectures. However, with the aid of an expert assistant, not one of the experiments failed. The first lecture was written out completely, and the evening

² In 1803 the second war with France was declared. This is the only reference that I have found in Dalton's letters to the French wars (1803-1815).

³ See “Memoir of John Dalton,” by R. Angus Smith, pp. 55-58. 1856.

before the lecture Davy and Dalton went to the theatre. Dalton read the whole lecture to Davy, who was in the furthest corner of the room. Then Davy read the lecture and Dalton was the audience, and then they criticized each other's methods. Next day he gave the lecture to an audience of 150 and was complimented on his *début*. After this he scarcely wrote anything, all being experiment or verbal explanation. This seems to have been his usual plan with all his lectures.

On returning to Manchester he gave to the Literary and Philosophical Society, on February 24, 1804, "A review and illustration of some principles in Mr. Dalton's Course of Lectures on Natural Philosophy at the Royal Institution in January, 1804." This was not published; this review was probably intended to fill up what would otherwise have been a blank evening.

It is unfortunate that we have no record of his 1804 lectures, which he states contained his views on certain primary laws. He left a statement for publication in the *Journal of the Royal Institution*, but he was not informed whether this was done. I have not been able to trace this.

1805.

After returning from London Dalton decided to give lectures in Manchester and issued the following preliminary statement:—

PROSPECTUS
of an intended course of
Lectures on Natural Philosophy
IN MANCHESTER,
BY
JOHN DALTON.

In a populous town like this, where the Arts and Manufactures are so intimately connected with various

branches of science, it may be presumed that public encouragement will not be wanting to a person qualified to exhibit and illustrate the truths of experimental philosophy upon a liberal and extensive scale.

Notwithstanding this, it would be imprudent for one of limited resources to purchase a large and expensive apparatus adequate to the object, upon a mere presumption. Something like a certainty of remuneration in a degree may fairly be expected.

With this view I propose, if a competent number of subscribers at two guineas each be procured, to extend the apparatus already in my possession so as to give a course of twenty lectures on the various branches of experimental philosophy, in the ensuing spring. Having for many years been engaged in the cultivation of the sciences of Mathematics and Natural Philosophy, and having lately delivered a course of lectures similar to the one proposed, in the Royal Institution at London, I may perhaps have some claim upon public confidence.

Each subscription ticket will admit a gentleman and a lady, or two ladies. The lectures will be delivered twice, if the number of subscribers exceed sixty, in order to their greater accommodation.

Those who wish to favour the undertaking will oblige me by putting down their names as early as may be on papers left for the purpose at Messrs. Clarkes' or Messrs. Thomson & Son's, booksellers,

Falkner Street, Jan. 2nd, 1805.

Russell, Printer, Manchester.⁴

⁴ The last section of Vol. ii. of Dalton's Manuscript Notes is made up of some spare copies of the above Prospectus. (See Roscoe & Harden, p. 66). The spelling of Falkner Street was subsequently changed to Faulkner Street. In 1805 Dalton went to live with the Rev. William Johns, at 10, George Street, where he remained until 1830. He then took a house at 27, Falkner Street. This he occupied until his death in 1844. The house was then taken by H. P. Rée and Co. (see Manchester Directories).

Shortly after the issue of the prospectus he informed his brother that he intended setting off to London "with a view to purchase apparatus; the number of subscribers the first week were upwards of 30, but it would be two or three months before the Lectures would begin." Some of the more important pieces of apparatus that he purchased are in possession of the Literary and Philosophical Society. The collection cost about £200, and was obtained from W. & S. Jones, Instrument Makers, of 30 Holborn, London. Dalton drew up a special syllabus for the lectures which were arranged as shown:—

	No. of Lectures.
Matter, Motion and Mechanical Principles ...	2
Hydrostatics	1
Pneumatics	2
Hydraulic and Pneumatic Instruments ...	1
Electricity and Galvanism	3
Magnetism	1
Optics	2
Heat	2
Elements of Bodies and their Composition ...	1
Mixed elastic Fluids and the Atmosphere ...	1
The Absorption of Gases by Water, etc. ...	1
Meteorology	1
Astronomy	2
Total ...	20

Writing to Jonathan Dalton in May, 1805, he tells us that the course is about half-finished, and that "a more respectable audience has seldom been had on a similar occasion, and things have gone on very well so far." Dalton evidently intended to detail in his Ledger the financial result, but beyond giving the heading no figures were added.

1806.

The success of the Lectures induced him to repeat the course in the following year and he inserted in the *Manchester Mercury and Harrop's General Advertiser* an advertisement:—

LECTURES
ON NATURAL PHILOSOPHY.

J. Dalton intends to deliver a course of Lectures on Natural Philosophy, comprising Mechanics, Pneumatics, Electricity, Galvanism, Magnetism, Optics and Astronomy; together with the doctrines on Heat and Pneumatic Chemistry, containing recent discoveries on those subjects. The whole to be illustrated by experiments with select apparatus, executed by the most modern artists.

The course will consist of about twenty Lectures. Tickets for the Course £2. 2. Each ticket admits a Gentleman and a Lady, or two Ladies. If the proposal meets with encouragement, the Lectures will commence about the end of January, in a central situation in Manchester, of which due notice to the subscribers will be given.

Those who wish to become subscribers will please give in their names at Clarks' or Thomsons' Booksellers, or to
J. Dalton, No. 10, George Street,
January 6, 1806.

He wrote to his brother on the 30th Nov., 1806:—"I am very busy, being in the midst of a Course of Lectures, and having a good deal of private tuition besides." The lectures added considerably to his small income. The total receipts were £65. 9s. 6d., which after deducting expenses gave him a balance of £58. 2s. od.

1807.

This year marks an important era in his lectures. He went to Edinburgh and he tells us that "soon after

my arrival I announced my intention to lecture by advertisement of handbills; I obtained introduction to most of the professional gentlemen in connection with the college, and to others not in that connection, by all of whom I have been treated with the utmost civility and attention; a class of 80 appeared for me in a few days; my five lectures occupied me nearly two weeks." He was afterwards induced to give a second course, and then proceeded to Glasgow, where he also lectured. He was very pleased with his reception, for "on these occasions he was honoured with the attention of gentlemen, universally acknowledged to be of the first respectability for their scientific attainments; most of whom were pleased to express their desire to see the publication of the doctrine." This stimulated Dalton to prepare for the press "A New System of Chemical Philosophy," Part I. of which appeared in 1808. It is dedicated "to the Professors of the Universities and other Residents of Edinburgh and Glasgow, who gave their attention and encouragement to the lectures on Heat and Chemical Elements, delivered in those cities in 1807; and to the members of the Literary and Philosophical Society of Manchester, who have uniformly promoted his researches."

He issued a special syllabus of the course of the Five Lectures, of which two were devoted to heat and the remainder to chemical elements. He was absent in Scotland for eight weeks and his expenses were £30, but no record has been found of his receipts.

1808.

Dalton prepared for his next course of 15 lectures in Manchester a 24-page pamphlet forming a very full epitome of his lectures. The title is:—

SYLLABUS
OF
A COURSE OF LECTURES
ON
Experimental Philosophy
BY
JOHN DALTON.

It is divided as shown below :—

- | | |
|------------------|----------------------------------|
| Lect. 1 and 2. | On Matter, Motion and Mechanics. |
| Lect. 3. | Hydrostatics. |
| Lect. 4 and 5. | Pneumatics. |
| Lect. 6. | On Hydraulics. |
| Lect. 7. | On the Steam Engine. |
| Lect. 8 and 9. | On Electricity. |
| Lect. 10. | On Galvanism. |
| Lect. 11 and 12. | On Optics. |
| Lect. 13. | On Meteorology. |
| Lect. 14 and 15. | On Astronomy. |

From these lectures he realised nearly £50.

1809-10.

On the 21st December, 1809, Dalton commenced a second course of lectures on Natural Philosophy at the Royal Institution, London. After an introductory lecture he dealt with :—

- | | |
|----------------------|--------------------|
| Lectures 2 and 3. | Laws of Motion. |
| „ 4 „ 5. | Pneumatics. |
| „ 6. | Hydrostatics. |
| „ 7 „ 8. | Steam Engine. |
| „ 9 „ 10. | Electricity. |
| „ 11 „ 12. | Meteorology. |
| „ 13 „ 14. | Astronomy. |
| „ 15 „ 16. | Heat. |
| „ 17, 18, 19 and 20. | Chemical Elements. |

In a small memorandum book some of the lectures are written out almost in full. Lectures 15 to 20 have been transcribed and printed.⁵

He informs his brother in April, 1810, that his twenty lectures were attended by an audience "of 1, 2, or 3 hundreds and he received the strongest marks of approbation."

The fee for the lectures was again 80 guineas and Dalton estimates his expenses for 7 weeks at £35.

1811.

In *Cowdroy's Manchester Gazette* (January 19th, 1811) Dalton advertises a course of Lectures on Experimental Philosophy and Chemistry to be given at the Lecture Room of the Literary and Philosophical Society. He states that the course will be nearly the same as that he delivered in London. In a letter to Jonathan Dalton, dated 4 mo., 29, 1811, he writes: "The engagements I allude to above have been to give a course, or rather two courses of lectures on Natural Philosophy and Chemistry, which have required extraordinary exertion, as I was obliged to attend a good deal of private tuition in the meantime. They continued for 10 weeks and ended about a fortnight ago.—The produce of the lectures was nearly £130, which exceeded any I have had before."

For these 20 lectures he prepared a new syllabus, which includes the subjects of Mechanics, Hydrostatics, Pneumatics, Hydraulics, Electricity, Galvanism, Optics, Meteorology, Astronomy and Chemistry. The last subject included Heat.

1814.

In this year Dalton gave a course of Lectures on Natural Philosophy and Chemistry in Manchester. For

⁵ See Roscoe and Harden. Chaps. I. and IV.

the introduction to these lectures see Roscoe & Harden, p. 125. The lectures were well attended.

1817-18.

In 1817 Dalton received an invitation to lecture at the Birmingham Philosophical Institute. He dealt with Chemistry. In the following year he again visited Birmingham, this time the lectures being on Mechanics. For each set of lectures he received 40 guineas.

Writing to his brother on the 13th January, 1818, he expresses his satisfaction with his reception in Birmingham and adds :—

“I was pleased with the philosophical taste displayed by the Society, especially the leading characters amongst them; they have an excellent lecture room, a good apparatus in several departments and raise two or three hundred subscribing members of the institution.”

During this year he also gave 15 lectures in Manchester on Mechanics, etc., the subscriptions amounted to nearly £57, the expenses were about £17, which included £10. 10s. for the hire of the lecture-room.

1820.

In this year he decided to give Electricity the first place in his lectures. He advertised in *Cowdroy's Gazette* and the *Manchester Mercury* as shown below :—

LECTURES ON NATURAL PHILOSOPHY.

J. DALTON intends to commence his COURSE of LECTURES on NATURAL PHILOSOPHY on Monday evening, the 6th of March, at seven o'clock, at the Rooms of the Literary, and Philosophical Society, George-street.

The Course will consist of ten Lectures, viz. three on

Electricity, one on *Galvanism*, two on *Optics*, two on *Astronomy*, and two on *Meteorology*.

Tickets for the Course, at *One Guinea* each, may be had at Messrs. Clarkes', or Mr. E. Thomson's, booksellers; or at No. 10, George-street.—A Ticket will admit *one* Gentleman or *two* Ladies.

* * * Part I of Vol. 2 of the New System of Chemical Philosophy will be published in a few months.

February 26, 1820.

A new syllabus for the lectures was prepared and many electrical experiments arranged. The nature of the electrical lectures will be seen from the detailed notes:—

“*Lect. 1, 2 & 3.* ELECTRICITY. Historical sketch of the science—attraction—repulsion—positive and negative electricity—conductors and non-conductors—insulation. Electric machine—theory of its action. Experiments on attraction and repulsion with cork ball—feathers—head of hair—dancing images—musical bells. Different influences of balls and points in attracting the electric fluid—snapping tube. Leyden phial or electric jar—charging and discharging ditto—electric shock. Magic picture. Nature of the electric fluid—compared with light and heat—electric stool—human body a good conductor—jar charged from it. Electric spider—dancing pith-balls. Electrometers—pith-ball—quadrant—Cuthbertson's—medical—Bennet's gold-leaf. Medical electricity—the spark—shock—aura. Paper perforated by the discharge of a jar. Electricity prefers a bad *short* conductor to a good *long* one. Inflammation of bodies by electricity—as cotton—spirits—hydrogen gas, &c.—thunder and lightning—thunder house—conductors. Electric battery—fusing wires, &c. Electrophorus, experiments on it—luminous experiments.

Lect. 4. GALVANISM. Discovery of Galvanism in 1791—a very distinct branch of electricity. Experiments with silver and zinc. Perfect and imperfect conductors—simple galvanic train—a number of these connected constitute a battery. Galvanic trough. Galvanic charge supposed to differ from an electric as a low charge of an electric battery differs from a high charge of a jar—hence the little importance of insulation. Tin end of trough positive—copper end negative. Galvanic shock—acid and alkaline tastes by positive and negative wires. Decomposition of water, alcohol, &c. by galvanism. Medical application. Theory of the battery—*number* and *magnitude* of plates, &c.”

The financial result was again satisfactory. £74. 15s. od. was paid by the subscribers, the chief items of expenditure were advertising, printing the syllabus and hire of lecture room, the total being £12. 6s. od.

1823.

Lectures at Leeds Philosophical and Literary Society. He gave six lectures, four being on Mechanics and two on Meteorology. He was paid 50 guineas. In his memoranda of expenses amounting to £10. 8s. od. there is a bill for three weeks' board and lodging for £4. 6s. od.

1824.

This year commences Dalton's association with the Medical School, when Thomas Turner proposed to establish a School of Medicine and Surgery. The project being well received, Turner took a house in Pine Street, a small street between George Street and Falkner Street. Dalton joined the staff of seven, taking Pharmaceutical Chemistry as his subject.⁶

⁶ See “Sketches of the Lives and Work of the Honorary Medical Staff of the Manchester Infirmary.” By E. M. Brockbank. 1904. Manchester: at the University Press.

Apparently the arrangement was that Dalton should receive the fees of the students attending his lectures and pay all expenses. In the *Manchester Guardian* for December 4th, 1824, will be found the first announcement relating to the lectures:—

TO MEDICAL STUDENTS.

John Dalton, F.R.S., President of the Literary and Philosophical Society, intends to commence a course of about fifteen lectures on Pharmaceutical Chemistry at Mr. Turner's Lecture Room, Pine street, on Tuesday evening, the 7th December, at seven o'clock.

The Lecturer, after explaining the first principles of Chemistry, will proceed to apply them to investigations respecting the *Materia Medica*, and to other purposes relating to the profession.

Tickets for the Course at One Guinea each may be had of Mr. Dalton, at No. 10, George street.

According to his usual custom Dalton prepared a printed syllabus for these special lectures, the chief subdivisions being:—Introduction, Heat or Caloric, Constitution of Bodies, Chemical Syntheses and Analyses, Simple or Elementary Gases, Elementary Solids, Compound Bodies, Alkalies, Acids, etc., Earths, Sulphurets, Metals, Vegetable Kingdom, and Animal Kingdom.

He received fees amounting to £27. 8s. od., but his expenses were £10. 10s. od.

Mr. Turner, in his report in 1825 relating to the work of the previous session of the Medical School, says:—

On the Application of Chemistry to Medicine and Surgery.

Mr. Dalton, whose philosophical attainments were too well known to require any panegyric, had last year delivered a course of Lectures which he would shortly repeat.⁷

⁷ *Manchester Guardian*, Oct. 1st, 1825.

The Ledgers and Memorandum Books of Dalton show that he continued his connection with the Medical School for at least six sessions; in the later periods he had each session three separate classes attended by 8 or 9 students.

In responding to the toast of "Dr. Dalton and that excellent Institution, the Literary and Philosophical Society, of which he is the distinguished President," at the Anniversary Dinner of the Pine Street School of Medicine and Surgery, in 1833, Dalton made a short but memorable speech in which he says:—

"With regard to myself I shall only say, seeing so many gentlemen present who are pursuing their studies, that if I have succeeded better than many who surround me, in their different walks of life, it has been chiefly, nay I may say almost solely from unwearied assiduity. It is not so much from any superior genius that one man possesses over another, but more from attention to study and perseverance in the objects before them, that some men rise to a greater eminence than others."

1825.

In the *Manchester Guardian* for October 1st, 1825, Dalton advertises that he intends to give a course of six lectures on Meteorology. He prepared a new syllabus and wrote out an introduction to the course. This is reproduced below:—

METEOROLOGY.

Manchester, Sep. 22, 1825.

Introduction: The Science of Meteorology is that which treats of the various Phenomena of the Atmosphere; as *Winds, Clouds, Rain, Snow, Dew, &c.*—and of Meteors more strictly so called, as *fery Meteors* or *falling*

stars, Luminous balls, Thunder and Lightning, Aurora borealis, &c.

Most men who have cultivated the Physical Sciences with success, have had their attention drawn to this branch in an especial manner. Indeed it is not surprising that this should be the case, from the interest which every one must feel in the state of the weather, not only as it influences their own health and comfort, but as it affects the enjoyment of society at large.

Meteorological Journals are now kept in almost every part of the globe where Natural Philosophy is cultivated ; and it is to be regretted that we have not observations in all parts of the globe ; as facts and observations form the most stable bases for Theories on this or any other subject of Philosophy.—For instance, the late warm and dry Summer, &c., &c.

I began to register my Meteorological Observations 38 years ago, and have continued them to the present time. The *Aurora borealis* was a principal cause to induce my commencement of a register. This splendid phenomenon was of frequent occurrence at that time, and afforded me great scope for investigation for 4 or 5 years at Kendal. Since that period the phenomena have been rare in this part of Europe.

On leaving Kendal I published a small volume of meteorological observations and essays ; the chief merit of which (if it have any) consists in explaining the two great causes of wind—and in describing the observations of the *Aurora borealis* so as to lead to a theory of this wonderful appearance.—In the succeeding years I have published occasional Essays in the Memoirs of the Literary and Philosophical Society of this Place on meteorological subjects.

Abundance of light has been thrown on the nature of

elastic fluids during the last 50 years. Indeed, before that period, the atmosphere may be said to have been considered as a homogeneous fluid. As soon as it was discovered that elastic fluids of very different chemical properties existed in the atmosphere, and were mostly or always found in a state of intimate mixture, it became a question how this mixture was effected and maintained; especially as the elastic fluids are of very different specific gravities. A notion was adopted that it must be the result of chemical affinity, and analogous to the solutions of salt, sugar, &c., in water. But the analogy does not hold; for salts do not dissolve in water without agitation; whereas airs dissolve in each other without agitation. Also, salts produce cold, or heat, and condensation of volume; whereas airs produce none of these.

Considerations of this kind, together with the enormous disproportion in which the elastic fluids constituting the atmosphere are found mixed, put me upon thinking, about 25 years ago, whether a more rational account might not be given of the constitution of the atmosphere. This led to such views of the subject as terminated in a new theory of chemical combination in general, or what is called the *atomic* theory.—But this is a subject we must not enlarge upon at present.

The Manchester lectures realised £27. 12s. 0d. The same course was also given at the Birmingham Philosophical Institute, for which he received 40 guineas.

1827-29.

During these years his lectures in Manchester were devoted to Heat and Chemistry. The printed syllabuses for the three years differ but little and are chiefly based on his "New System of Chemical Philosophy." His account books show that he received on an average about £80 for

each public course of lectures. In addition he gave private courses of lectures to small classes, each with about eight pupils.

1834.

During March and April of this year a course of lectures on Meteorology was delivered by Dalton at the Royal Manchester Institution, for which he received 20 guineas.

1835.

At a meeting of the Directors of the Manchester Mechanics' Institution in 1834, Mr. Benjamin Heywood was appointed to see Dr. Dalton and to ask him if he would favour the Institution with a course of lectures on any subject. At a subsequent meeting Mr. Heywood reported that he had seen Dr. Dalton "who in a very handsome manner had consented to deliver a course of lectures in the Institution. Dr. Dalton proposed to deliver five lectures on Meteorology and at once agreed to the suggestion of fifteen guineas as remuneration."⁸ Reports of the lectures, which commenced in March, are given in the *Manchester Guardian* for 1835, where it is stated that the lectures were well attended.

Later in the year Dalton gave a lecture at the Mechanics' Institution on the Atomic Theory. To the audience was distributed a lithographed sheet of Atomic Symbols. This lecture attracted great interest, the *Manchester Times* of October 25, 1835, reported that "the lecture-room was crowded in every part and the greatest anxiety was manifested by the audience not to lose a single word which fell from the lips of the speaker." This is his last public lecture of which any record has so far been found.

⁸ See the Minutes of the Manchester Mechanics' Institution, which are preserved in the Library of the Manchester School of Technology.

The Directors of the Institution in November, 1835, resolved that a silver inkstand of the value of ten guineas be presented to Dr. Dalton, with an inscription expressive of the sense of the Directors of his patronage of the Institution. The inscription decided upon was as shown below :—

JOHN DALTON, D.C.L., F.R.S.,
President of the Manchester Literary and Philosophical Society,
&c., &c., &c.,
From the Directors of the Manchester Mechanics'
Institution
in grateful acknowledgment of services rendered by their
distinguished Townsman.
January, 1836.

The inkstand, on the death of Dalton, became the property of Peter Clare, who presented it to the Literary and Philosophical Society, with the added inscription :—

This silver Inkstand was bequeathed by the late Peter Clare, F.R.A.S., to the Literary and Philosophical Society of Manchester, of which he was one of the Vice-presidents, to be used at their ordinary and other meetings. Nov., 1851.

For 64 years this inkstand has been in regular use at the meetings of the Society and is a memorial of the local appreciation of John Dalton's services as a lecturer.



DESCRIPTION OF PLATES.

PLATE I.—Syllabus of Dalton's Lectures given in 1791. Reproduced from Dalton's corrected copy.

PLATE II.—Extract from Dalton's Ledger of 1791, showing a profit of £6. 4. 2 from the above lectures.

KENDAL, Nov. 2, 1791.

J. DALTON'S
PHILOSOPHICAL LECTURES

WILL BEGIN

On Monday Evening the 14th of November, at 6 o'Clock, and continue on Mondays and Thursdays following.

Admittance Sixpence each Lecture, or five Skillings the whole.

LECTURES I. & II. MECHANICS.

On Matter, and its Properties. Attraction and Repulsion in general. Experiments upon electric, chymical, and particularly magnetic Attraction and Repulsion. On Gravity. The Laws of Motion. Mechanic Powers. Vibration of Pendulums.

LECTURES III. & IV. OPTICS.

Nature and Properties of Light. Simple Vision. Doctrine of Colours. Of reflected Vision, Mirrours, &c. Of refracted Vision, Lenses, &c. Burning Glasses. Description of the Eye, and manner of Vision. Of Optic Glasses. The Rainbow explained.

LECTURES V. & VI. HYDROSTATICS & PNEUMATICS.

Of Fluids in general. Properties of elastic Fluids. Specific Gravity of Bodies. Of the Atmosphere. Description of the Air-Pump. A great variety of Experiments on the Air-Pump, proving the Spring, weight, and other Properties of the Air. Account of Discoveries upon fictitious Air, and common Air injured by Respiration, Putrefaction, Combustion, &c.

LECTURE VII. ON FIRE.

The Thermometer: Discoveries relative to Heat consequent thereto. Of the source of Animal Heat, and the nature of Combustion.

LECTURES VIII. IX. & X. ASTRONOMY.

Of the Solar System, and System of the Universe. Various astronomical Phenomena as the Phases of the Moon, Eclipses, Occultations, Transits, &c. explained. Of Tides.

LECTURES XI. & XII. USE OF THE GLOBES.

Description of the Globes, and a variety of Problems performed, and Phenomena illustrated by them.

KENDAL: PRINTED BY W. PENNINGTON.



1791	Philosophical Lectures	£ 0 2
1792	of Five 2/3, Landles 4/10 1/2	7 1 1/2
	Reverberations 4th Paper 1/6 (Leaving both 1/3. d. 1/4 1/6)	7 1 1/2
	Sundry small Expenses	4 1/2
	Profit of Pop. gains	6 4 1/2
		7 - 6



Part II.

John Dalton's Natural Philosophy Diagrams.

MECHANICS.

Sheet 1.

(17" broad \times 21" high.) Three diagrams illustrating the principle of the lever.

Sheet 2.

(32" \times 21".) Four diagrams illustrating the pressure on fulcrums and supports.

Sheet 3.

(22" \times 31".) Three diagrams relating to the pressures produced when beams are suspended horizontally.

Sheet 4.

(13" \times 19".) Three diagrams illustrating the inclined plane. A weight of 12 units is shown balanced by 3, 4 or 6 units according to the inclination of the plane.

Sheet 5.

(21" \times 17".) Two diagrams illustrating statical principles.

- (1) Three equal forces act at an angle of 120° on a body.
- (2) Forces of 14, 8 and 15 act on a body.

Sheet 6.

A large diagram (34" \times 41") illustrating the principle of moments. Weights are suspended at three points on the circumference of a disc which is pivotted about a central horizontal axis.

Sheet 7.

(20" \times 16".) Relates to the parabolic path of projectiles.

Sheet 8.

(22" × 32".) Illustrates the simple pendulum. Two pendulums are shown vibrating through the same angle. Ratio of length of pendulums are as 1 : 4.

Sheet 9.

(21" × 17".) Compares the rates of efflux of water from the same head of water with five different kinds of jets.

Sheets 11 to 21.

These are copied with some modifications from Peter Ewart's paper on "Moving Force."⁹

Peter Ewart was elected a member of the Literary and Philosophical Society in 1798, and for 22 years was a Vice-President. In 1835 he became the Chief Engineer and Inspector of Machinery in the Government Dockyards at Woolwich. In writing his paper on "Moving Force" he was assisted by Dalton, who suggested some of the experiments described. In his Royal Institution Lectures in 1909-10 Dalton tells us "that several have been wonderfully struck with Mr. Ewart's doctrine of Mechanical Force." Part I. of Vol. II. of "The New System of Chemical Philosophy" (1827) is dedicated to

John Sharpe, Esq., F.R.S.,

and to

Peter Ewart, Esq.,

Vice-President of the Literary and Philosophical Society of Manchester, "on the score of friendship, but more especially for the able exposition and excellent illustra-

⁹ See *Manchester Memoirs*, 2, 2nd Series, p. 105. Also see "Some Account of the late Mr. Ewart's Paper on the Measure of Moving Force," by Eaton Hodgkinson, *Memoirs*, 12, p. 138; also an account of the same by J. Bottomley, in the "Centenary of Science in Manchester," by R. Angus Smith, p. 246.

tion of the fundamental mechanics, in his essay on the Measure of Moving Force."

Up to 1686 the force of a body in motion was measured by the product of the mass of the body into its velocity. Leibnitz thought that this was erroneous, and maintained that it should be the product of the mass into the square of the velocity. This he termed the *vis viva*, which is equal to twice the kinetic energy. The great controversy was not ended until the resistance to be overcome was taken into account. This may sometimes be conveniently measured by a space integral ($\frac{1}{2}mV^2$), and in other cases by a time integral (mV).¹⁰

HEAT.

Sheet 22.

Shows Fahrenheit, Centigrade and Réaumur thermometers, each with a length of 14 inches. They are marked in steps of 10 degrees between the freezing and boiling points. The spherical bulbs in each case are represented as full of mercury up to the freezing point. The Fahrenheit has two scales, one being the ordinary scale marked from -20° to 212° , and the other Dalton's new scale.

The new scale is described in Part I., section 1 of Dalton's "New System of Chemical Philosophy." It is based on Dalton's assumption that all pure homogeneous liquids expand from their point of congelation or greatest density by an amount proportional to the square of the rise of temperature from that point.

Dalton arranged that his new scale should agree with the Fahrenheit scale at 32° and 212° , and -40°F. was taken as the freezing point of mercury. Hence it can

¹⁰ See Routh's "Rigid Dynamics," Chapter VII., where references will be found relating to the history of the controversy.

readily be deduced that the value T on the new scale will be given by the formula:—

$$T = \left(\frac{\sqrt{F + 40} - \sqrt{72}}{\sqrt{252} - \sqrt{72}} \times 180 \right) + 32.$$

where F is the temperature on the Fahrenheit scale. Mr. Arthur Adamson finds that this formula agrees with the numbers calculated by Dalton.

We now know that the scale proposed by Dalton is untenable, and in the Appendix of the 1827 edition of Part I., Vol. II. of the "New System" he admits that it is so in the light of the researches of Dulong and Petit on the expansion of mercury.

Sheet 23.

Eleven thermometers are shown each 17 inches long, the spherical bulbs are blackened and so also is the lower part of the stems to a common level. The graduations on the thermometers are:—

No. 1.	Right side 1, 2, 3, 4, 5, 6, 7	
	Left side 1 ² , 2 ² , 3 ² , 4 ² , 5 ² , 6 ² , 7 ²	
„ 2.	Earthenware (1)	in 10° spaces from 36 to 106
„ 3.	Earthenware (2)	„ „ „ „ 40 to 110
„ 4.	Glass	„ „ „ „ 41½ to 111½
„ 5.	Iron	„ „ „ „ 42½ to 112½
„ 6.	Tinned Iron	„ „ „ „ 42½ to 112½
„ 7.	Copper	„ „ „ „ 45½ to 115½
„ 8.	Brass	„ „ „ „ 46 to 116
„ 9.	Pewter	„ „ „ „ 46 to 116
„ 10.	Lead	„ „ „ „ 49½ to 119½
„ 11.	No graduations.	

Sheet 24.

(19" × 33".) This is marked by Dalton:—"Water therm." On the left-hand of the sheet two thermometers

are shown. On one there is a scale against which Dalton has written:—"Reformed graduations as the square of the temperature," and against the other, "Graduations of water therm. to correspond with common scale of mercurial thermometer." These show graduations from 42° to 212°. On the middle of the sheet these scales are again drawn on a larger scale, with only seven graduations. On the right is hand-printed:—

Water Therm.			
Lowest Point.			
In Earth-Ware	38
Stone-W.	40
Glass	41½
Iron	42½
Copper	45½
Brass...	46
Pewter	46
Lead	49½
Zinc	(no number)

These numbers correspond nearly with those on p. 31 of Part I. of the "New System."

On the bottom of the diagram the following numbers are tabulated:—

		6°	16°	26°	38°	48°	56°	66°	76°	86°		
		9	7	5	3	1	1	3	5	7	9	real exp.
		2	2	2	2	2	2	2	2	2	2	glass, etc.
		11	9	7	5	3	1	1	3	5	7	appar. exp.

which further illustrate Dalton's experiments on the maximum density of water. He concluded that this greatest density is at or near 36° of the old scale, and 37° or 38° of the new scale.

Sheet 25.

This is drawn on rough paper and is 8 feet long and 7 inches wide, formed of three slips of paper pasted together. It is labelled "Water Therm." and shows a long thermometer with a large spherical bulb. This and part of the stem up to 42° are shaded to represent the water. The remainder is graduated in steps of ten degrees, 52° , 62° , etc., up to 212° , the distances between these divisions are gradually increased, showing the increasing rate of expansion of the water.

Sheet 26.

Labelled "Old and New Scales, 32° to 212° ." A diagram 27 inches long and 6 inches wide, showing adjacent scales marked in steps of 10 degrees.

Sheets 27 to 29.

These diagrams were used to make clear the difference between temperature and capacity for heat. No. 27 ($20'' \times 33''$) shows two vessels of different capacity connected by a stopcock. In No. 28 ($17'' \times 21''$) there are three independent vessels of different sizes filled to the same level with a liquid. No. 29 ($19'' \times 14''$) is a hydrostatic analogy relating to the "method of mixtures" used in calorimetry.

Sheet 30.

A diagram 41in. long and only 4in. wide. It is weighted at the bottom by a piece of lead so that it will hang vertically. It shows graphically the relative expansion of:—

1.	Glass, etc.	$\frac{1}{400} = 25.$
2.	Lead, etc.	$\frac{1}{118} = 86.$
3.	Mercury	$\frac{1}{55} = 180.$
4.	Water	$\frac{1}{22} = 465.$

5.	Salt Water	$\frac{1}{20}$	= 500.
6.	Sul. and Mur. Acid	$\frac{1}{17}$	= 600.
7.	Ether, oil Turp.	$\frac{1}{14}$	= 700.
8.	Oils	$\frac{1}{12.5}$	= 800.
9.	Alcohol, Nit. Aci.	$\frac{1}{9}$	= 1100.
10.	Air	$\frac{3}{8}$	= 3750.

The above is printed by hand on the chart, and the right-hand numbers, after dividing by 100, are used to show graphically the expansion. Thus air is represented by 37.5 inches, alcohol by 11 inches and so on. In each case it is the coefficient for cubical expansion from 32°F. to 212°F. that is represented by the fractional numbers. If these be compared with the Table on p. 44 of the 1808 edition of Part I. of the "New System" it will be found that they all agree with the figures given in the Table, with the exception of mercury, which is given as high as $\frac{1}{50}$. The value $\frac{1}{55}$ is nearer the $\frac{1}{55.5}$ which Dalton quotes from the experiments of Dulong and Petit, given in the 1827 edition of Part First of Vol. II. of the "New System." It hence seems probable that the diagram No. 30 was made after 1819, when the experiments of Dulong and Petit were published.

Sheets 31 and 32.

These diagrams are very similar to that given in Plate 2, Part I. of the "New System," but better adapted for lecture use. They both show logarithmic curves representing Dalton's law for the increase of vapour pressure with temperature. In the case of No. 31 a diagram is added which shows a barometer tube containing mercury with water on the surface of the mercury. The tube has a heating jacket surrounding its upper part, whilst the lower part is bent and graduated for pressure measurements. No. 31 (22" x 33") relates to water only,

but in No. 32 (19" × 32") the values for ether are also shown. Dalton's law may be given in the form:—

$$\log p = A + B\theta$$

where p is the pressure, A and B constants, and θ the absolute temperature. Modern experiments have shown that

$$\log p = A + \frac{B}{\theta}$$

more nearly expresses the law for water.

Sheets 34 and 35.

These are smaller diagrams (19" × 24") and have no lettering. They were used by Dalton in his earlier lectures, when dealing with the steam engine. No. 35 explains the method of Savary (1698) for raising water by suction into a vacuum produced by the condensation. In the diagram a safety valve is shown which was not applied by Savary, but invented in 1717.

No. 36 is Newcomen's engine (1705-7). The diagram shows the method of injection into the cylinder, but no safety valve or method of feeding the boiler is represented.

Sheet 36.

(20" × 15".) Leslie's experiment on the reflection of heat. In the focus of one concave mirror is placed a bottle of hot water; in the focus of a second concave mirror is an air thermometer.

OPTICS.

Sheet 37.

(13" × 19".) Shows (1) a parallel beam and a diverging beam of light, (2) the reflection of a parallel beam from a plane mirror, (3) the refraction of a parallel beam in passing through a prism, and (4) the diffraction of a parallel beam when passing through a small opening.

Sheet 38.

($9\frac{1}{2}'' \times 17\frac{1}{2}''$.) Probably used to illustrate the law of inverse squares. It consists of four blackened squares having the relative areas of 1 : 4 : 9 : 16. White lines are used to divide the larger squares into areas equal to the smallest square.

Sheets 39 and 40.

The first is a small diagram ($16'' \times 10''$) showing the method of the formation of the image of an object (a Latin cross) by a plane mirror. The second is like the last but larger ($21'' \times 16''$).

Sheet 41.

($17'' \times 21''$.) Two plane mirrors lettered A and B are inclined at an angle of 30° . Between them are two objects, a **x** and a **●**. The multiplication of the images of these objects is represented, there being eleven images of each. Dalton has marked the manner of the formation of each image. Thus one of the images of the **x** is marked

“ 1 *b* by *a* by *b* by *a* by *b* ”,

a and *b* referring to the mirrors A and B.

Sheet 42.

($21\frac{1}{2}'' \times 17\frac{1}{2}''$.) Multiplication of the images of a candle flame by a single plane mirror, due to the reflection from the front and back surfaces of the looking glass. The formation of seven images is represented.

Sheet 43.

A small diagram ($16'' \times 10''$) probably for use in small lecture classes. It shows the formation of images of Latin crosses (1) by a concave mirror giving an inverted

magnified real image, (2) by a concave mirror giving an erect magnified virtual image, and (3) by a convex mirror giving an erect, diminished and virtual image. Dalton has written "object" and "image" against the crosses. On the back of the diagram he has written "optical schemes."

Sheet 44.

A larger diagram ($21'' \times 16\frac{1}{2}''$) showing the production of images by curved mirrors. Two cases are drawn, the formation of an erect magnified virtual image by a concave mirror, and the formation of an erect diminished virtual image by a convex mirror. Each mirror has the same focal length, and the size of the object in front of the convex mirror is made equal to the image in the concave mirror, and since their distances from the mirrors are also equal, one diagram is the reverse of the other.

Sheet 46.

($21\frac{1}{2}'' \times 17\frac{1}{2}''$.) Two diagrams, the upper one representing the experiment of Newton. Light from the sun passes through a hole and falls on an equilateral glass prism which produces a spectrum. The lower diagram explains the well-known experiment, which Dalton showed in his lectures, of a coin placed in a vessel in such a position that the coin cannot be seen until water is poured into the vessel.

Sheet 47.

($17\frac{1}{2}'' \times 10\frac{1}{2}''$.) Illustrates the use of a Wollaston's prism as a Camera Lucida. The diagram shows the two reflections from the faces of the quadrilateral figure that are essential to prevent a reversed image.

Sheet 48.

($20\frac{1}{2}'' \times 16\frac{1}{2}''$.) This has four diagrams:—

- (1) The concentration of a parallel beam by a double convex lens to its principal focus.
- (2) The method of use of a double convex lens as a magnifying glass.
- (3) The formation of an inverted magnified real image by a double convex lens.
- (4) The formation of an image by a double concave lens.

Sheet 49.

($21'' \times 17''$.) The upper diagram explains the compound microscope. Three convex lenses are used to produce a magnification of an insect. The lower diagram relates to the solar microscope. Sunlight is reflected by a mirror and concentrated by a large convex lens on an insect. With the aid of a small convex lens of short focal length an enlarged image of the insect is produced.

Sheet 50.

($21\frac{1}{2}'' \times 17\frac{1}{2}''$.) This has five diagrams, explaining the optical principles of:—

- (1) The Gregorian reflecting telescope.
- (2) The common refracting telescope with erecting lenses.
- (3) The refracting astronomical telescope with four lenses.
- (4) A telescope with two convex lenses.
- (5) The opera glass.

Sheets 51 and 52.

The first is a small diagram ($10'' \times 8''$) showing how an inverted image is produced on the retina of the eye. The other sheet ($21'' \times 17''$) shows the previous

figure to a larger size, and has in addition three views of the eye with the pupil contracted, of normal size, and dilated.

Sheets 53 and 54.

(8" × 10½" and 17" × 20½".) These are in illustration of what Dalton has called the "optical principle" used in the "Essays" in connection with the Propositions concerning the Aurora Borealis, where he says "for it is known to every one, that celestial objects, and objects at a distance in the air, as the sun, moon, stars, meteors, etc., all appear at the same distance, though nothing can be more disproportionate than their real distances."

ACOUSTICS.

Sheet 55.

(22" × 18".) The transverse vibrations of strings showing the production of the fundamental note and harmonics. This is an enlarged drawing of one on a half-sheet of notepaper, found among Dalton's papers, on which he has written "Young's Theory of Harmonic Tones."

Sheets 56, 57 and 58.

The first is a small diagram (8" × 13") on which Dalton has carefully drawn seven organ pipes producing fundamental and harmonic tones, and has marked the position of the nodes and anti-nodes. He has also represented the condition of the air of the sound-wave by spirals whose diameter is gradually varied. Three relate to open and three to closed pipes. A pitch-pipe is also shown, which is provided with a piston for altering the length of the tube. No. 57 (16½" × 13") gives the first six cases. No. 58 (27" × 19") includes the pitch-pipe, four closed pipes and three open pipes.

ELECTRICITY.

Sheets 59 and 60.

No. 59 is a small diagram (3" × 23") illustrating Davy's explanation of electrolysis. It shows 6 "atoms" of water, the oxygen being indicated by ○ and the hydrogen by ⊙. The upper part of the diagram shows the position of the atoms when not connected with a battery, and the lower part shows the liberation of the gases at the electrodes when the current passes. This diagram is probably taken from a paper on "Theories of the Excitement of Galvanic Electricity" by William Henry (see *Memoirs*, 2, p. 311, 1813). No. 60 is a larger diagram (21" × 17") like 59 without showing any electrodes.

METEOROLOGY.

Sheets 61, 62, 63 and 64.

These relate to the Theory of Rain, which Dalton adopted and extended,¹¹ that was first given by Hutton.¹² The latter had pointed out that the quantity of vapour capable of entering the air increases at a greater rate than the temperature. Hence it may be concluded that when two volumes of air at different temperatures are mixed together, each being previously saturated, a precipitation must ensue, in consequence of the mean temperature not being able to support the mean quantity of vapour.

No. 61 (21" × 17") is headed "Theory of Rain," and shows a curve plotted connecting the pressure of saturated water vapour and its temperature. Dalton has written on the diagram the numbers used:—

¹¹ See Dalton's observations on the barometer, thermometer, and rain at Manchester, from 1794 to 1813 inclusive. *Memoirs* (2nd Series), 3, p. 483, 1819.

¹² "The Theory of Rain," by J. Hutton. *Trans. Roy. Soc. Edin.*, Vol. I., p. 41, 1788; Vol. II., p. 39, 1790.

New Scale.		Inches of Water.		Differences.
12°	=	1'523		
22	=	2'010	...	·487
32	=	2'652	...	·642
42	=	3'5	...	·848
52	=	4'618	...	1'118
62	=	6'094	...	1'476
72	=	8'041	...	1'947
82	=	10'61	...	2'569
92	=	14'	...	3'390

The curve shown is convex towards the horizontal line of temperatures.

No. 62. (27" × 19".) Like the previous diagram but the Fahrenheit scale is used. The departure of the curve from a straight line connecting the freezing and boiling points is much less marked than in No. 61.

No. 63 is like No. 61 but larger (32" × 22"). A straight line connecting the 30° and 90° points shows that at 60° the amount of water that must be precipitated when the temperature falls from 90° to 60° is considerable.

No. 64. A still larger diagram (41" × 34") like the last one but designed for a large lecture room. Straight lines are drawn connecting the 30° to 80°, the 30° to 50°, and the 60° to 80° points.

Sheet 65.

(27" × 19".) This has been intended by Dalton to explain Proposition III. of the "Mathematical Propositions necessary for illustrating and confirming those concerning the Aurora Borealis" (see "Meteorological Essays," p. 154, 1834). It shows a series of cylindrical beams equal and parallel to each other, all in a plane perpendicular to the horizon, and at equal distances from the horizon. These beams Dalton demonstrates will appear to an observer like a series of arches of a special shape. The diagram has not been completed.

Sheets 66 and 67.

Relate to the cause of the long-continued and irregular sound of thunder. About the year 1808 or 1809 (see "Meteorological Essays," 2nd Edition, Appendix, p. 202), it occurred to Dalton that if he could assume an electric discharge to be made instantly from one cloud to another, the distance apart of the clouds being say 12-14 miles, then the sound will be first heard from the nearest point, then from equidistant points and then from the furthest points. He gave this explanation at the Royal Institution lectures in 1810. No. 66 is a small (20" × 17") diagram that has been carefully made and painted. A cottage with a lightning conductor, a tree and a man are depicted. The suggestion has been made that this was drawn and coloured for Dalton by some artist friend. No. 67 is a much larger diagram (43" × 27"), and is a rough copy of 66. The explanation of the diagram is given on p. 203 of the "Essays." The clouds between which the lightning passes are supposed to be 14 miles apart. On the last page (p. 244) Dalton says that he has been informed that the above explanation was previously given by Boscovich. The name should have been Beccaria.¹³

Sheets 68 and 69.

The first of these (16" × 20") shows the gradual diminution of the density of the atmosphere as the height increases by the aid of a distribution of black dots. These are close together at the bottom of the diagram and the number in a given space is made to decrease gradually. In No. 69 (19" × 27") the decrease of density is shown by horizontal lines, these are close together at the bottom of the diagram and are drawn further

¹³ Lettere dell' elettricismo artificiale e naturale. Turin, 1753. See "History of Electricity," by Joseph Priestley, 4th Edition, 1775.

apart with increasing height. This diagram also shows a logarithmic curve.

Sheet 70.

(20" × 30".) A rough map of Great Britain showing an isogonic line. This is drawn through London, and the declination when read off by a protractor is 20°W.

Sheet 71.

(17" × 20".) A diagram explaining the theory of the winds.

ASTRONOMY.

Sheet 72.

(22" × 32".) This diagram is repeatedly referred to by Dalton in his Lecture Notes on Astronomy. In Lecture 8, April 17th, 1820, his rough notes give:—

“Gravitation explained—Earth, Diagram.

—Attraction of each particle of matter is inversely as the square of the distance.

—Force of Gravity at the Earth's surface Max.

—Force above, inversely as square of distance from centre.

—Force below—directly as distance from centre.”

The diagram (22" × 32") represents the earth attracting a weight of 1 at the surface of the earth and balances a weight of 4 placed at distance 2 from the centre of the earth. The weights are placed in the pans of a balance having short and long suspensions. The attraction at distance 2 is marked $\frac{1}{4}$, and at distance 3, $\frac{1}{9}$.

Sheets 73 and 74.

(20" × 16" and 22" × 18".) These Dalton used to explain Kepler's 1st Law, which he states as:—“A body revolving round any centre of force describes equal areas in equal times.”

Sheet 75.

(22" × 17½".) Kepler's 2nd Law. Dalton's statement of the law is:—"If several bodies revolve around a common centre of force, and if the *squares* of the Periodic Times are as the *cubes* of the distance, then the central attraction decreases as the square of the distance increases." The diagram refers to the cases of the Earth and Mars, which have relative distances of 2 and 3½, and periodic times of 1 and 2 respectively, hence

$$\frac{2^3}{3\frac{1}{2}^3} \text{ should be equal to } \frac{1}{2^2}$$

and this is found to be approximately the case.

Sheet 76.

(17" × 21½".) Shows that the orbits of the planets are ellipses, the sun being in one focus.

Sheets 77 and 78.

(21" × 17".) The first explains the production of shadows by a body in the path of the sun's rays. The second one explains lunar and solar eclipses.

Sheet 79.

(21" × 17½".) Explains the transit of Venus.

From Dalton's notes:—

"1639. Horrox of Toxteth predicted the transit of Venus—communicated it to Crabtree of Broughton. They both saw it, the first time that ever was seen—this extra. youth died in the 22nd year of his age."

Sheet 80.

A circular diagram, 17" diam. This represents the size of the sun, the relative sizes of the planets are shown within the circle.

Sheet 81.

(29" × 21".) Explains the production of tides.

Sheet 82.

(17" × 5½".) Shows a beam of light from the sun falling on a surface placed at right angles to the beam, and the spreading of the beam when it falls on a horizontal surface.

Sheet 83.

(21" × 17½".) This is designed to explain the relation between latitude and the sun's altitude.

Sheet 84.

(8" × 8".) Represents the projection of a sphere with meridians and circles of latitude.

[Sheets 10, 33, 45, and nine others remain unclassified.]

Part III.

The Lecture Sheets Illustrating the Atomic Theory.

By HUBERT FRANK COWARD, D.Sc.,

AND

ARTHUR HARDEN, D.Sc., Ph.D., F.R.S.

(Read May 11th, 1915. Received for publication May 31st, 1915.)

Towards the end of the eighteenth century and during the early part of the nineteenth, John Dalton delivered courses of lectures on Natural Philosophy in Kendal, Manchester, London, Edinburgh and Glasgow, and other places.¹⁴ During his development of the atomic theory, from about 1803 onwards, Dalton's lectures dealt more and more with chemistry, and were illustrated by chemical experiments and by sheets of diagrams which he prepared with considerable care. Recently some 150 of these lecture sheets were found in the rooms of the Society, and of these the 53 which illustrate the atomic theory are described in the present Memoir.

While no new view of the origin of the atomic theory has been disclosed by them, they nevertheless present some highly interesting points to the student of the history of science. In general they show that Dalton made much more use of his symbols in oral explanations of the theory than in his published works or even in his laboratory note-books. Thus, besides two tables of atomic weights and symbols, some 34 of the sheets

¹⁴ For a list of these, see Part I.

represent the composition of "compound atoms" of the most diverse inorganic and organic compounds.

Very little of Dalton's published work deals with organic compounds. The sheets show, however, that he used his atomic symbols for picturing the constitution of the commoner compounds of vegetable and animal origin, probably for exhibition during courses of lectures on pharmaceutical chemistry. The symbols were not put together in a haphazard fashion; for example, Dalton introduced a "vegetable atom," composed of one atom each of carbon, hydrogen and oxygen, as a constituent of such different substances as citric acid, sugar and wood. This conception of the radical marks an intermediate stage between Lavoisier's idea and the later theories of compound radicals. Dalton also clearly expressed by his symbols the conception of isomerism, as shown by sheet 23 (reverse), reproduced in *Plate VII*, where the compound atoms of two different substances are represented by "ultimate atoms," the same in nature and number but differently arranged.

Surprise has been expressed that Dalton could not bring himself to adopt Berzelius' system of chemical nomenclature. These diagrams, especially those dealing with organic chemistry, render Dalton's attitude towards Berzelius' system much more intelligible; for his symbolic expression of the *constitution* of substances is much simpler than that of Berzelius. It may indeed be said that while modern chemistry has adopted the symbols of Berzelius, it has used them much in the Daltonian fashion.

Dalton's formulæ for organic compounds are, however, very different from those now accepted.

One of the two sheets of atomic weights seems to have been the second ever presented to the public. It was prepared, together with several of the other sheets,

for the lecture course delivered in Edinburgh and in Glasgow in the spring of 1807.

Two of the sheets, numbered 34 and 35, represent reacting quantities by formulæ, almost in the manner of a modern chemical equation.

A minor point which has come to light in the course of the study of Dalton's note-books in connection with the diagrams, is a tri-dimensional formula for oxamide. (Laboratory Note-book xi., p. 372, March, 1834.) Oxamide was supposed to consist of one atom each of carbon, hydrogen, oxygen and nitrogen, and these are figured in the form of a tetrahedron, so that each atom is similarly placed, in contact with the other three.

Sheet I.

Plate III.

"ELEMENTS."

Several of the figures have been altered from those originally inserted. Some of these alterations are visible in the reproduction, the others can only be observed in the original. Most of the figures have been enlarged since they were first inserted. The corrections detected are:

Sulphur, from 12 to 13.

Magnesia, originally 20, as shown in the plate, was later covered with a slip of paper holding the figure 17. At some later time the slip became detached, but the ink stain from the superposed slip is plainly visible.

Lime, from 23 to 24.

Iron was originally 40, then altered to 38, and finally covered with a slip of paper bearing the number 50. This slip has been detached in order to disclose the figures underneath, and is now shown in the reproduction alongside the figures which it covered.

Lead, from 95 to 90.

Silver, which now appears to be 190, was originally 100. The 1 has at some time been covered and a tail given to the first 0 to make it a 9. Some fibres of the fragment of paper which had been pasted over the 1 still adhere to the sheet.

Gold, originally 140, was altered to 90. A slip of paper pasted over the 1 is lost but has left the faint outline of one corner, as shown by the small difference of tint in the colour of the sheet in that region.

Platina was 100, then altered to 90 in the same way as the figure for silver. Fibre left by the covering slip is readily noticed on the sheet.

The date of the original preparation of this sheet can be determined when the figures and symbols on it are compared with those in Dalton's published works and especially with those in his manuscript note-books. In the first place it is evidently a very early list, although quite different from the first published one, which was appended to the paper "On the Absorption of Gases by Water," published in 1805 (*Memoirs* 6, 287). It contains, however, the names of the same twenty elements (so-called) as the first part of the first volume of his "New System of Chemical Philosophy," published in 1808. Certain differences between the figures and symbols of the sheet and the corresponding ones of the book are apparent, and by comparison with others prove that the sheet was the earlier of the two. Thus the symbols for lime, magnesia and gold were not the same as those in the book, and the atomic weights of sulphur and iron are certainly earlier than those of the book.

The published figures, therefore, point to the date of the sheet as between 1805 and 1808. The atomic weights found in the set of laboratory note-books kept by Dalton and now preserved in the Society's library, were next

compared with those of the sheet, and were found to point to its date as lying between October, 1806, and July, 1807. Whilst the figures for oxygen, azote, sulphur and phosphorus show that the sheet was not produced before 1805 or 1806, the most significant figure is that for iron, which at the first appearance of this sheet was 40. Now, in September, 1806, Dalton put the atomic weight of iron as 29 or 58; on October 22nd of the same year it became 40, but in July, 1807, was again altered to 50, and did not again become 40 so far as can be discovered. The other atomic weights are all in accord with the date ascribed, with the exception of two: the figure for carbon is 5·4¹⁵ on the sheet, a value not found in the published works or laboratory books until 1810 ("New System," I., ii.); for mercury the atomic weight on the sheet is 167, a figure which appears first in 1808 ("New System," I., i.) where it replaces the 166 of July, 1807, and October, 1806.

The latter difficulty is probably of no significance, since the difference is only of one unit in the large value 166 to 167. The former difficulty—the atomic weight of carbon being 5·4 when in contemporary lists it appears as 5—was removed as the result of an enquiry as to the reason for the compilation of this sheet of atomic weights. It seemed reasonable to expect that this was drawn up for use during some important lecture, and it was therefore no surprise to find that Dalton gave courses of lectures in Edinburgh and Glasgow in April, 1807. The notes for these lectures, which are also among the relics in the Society's library, contain worked out several atomic weights, together with reference to a "scheme" (apparently the present sheet). The atomic weight of carbon

¹⁵ Without doubt the figure in the first decimal place belonged to the original compilation of the sheet.

calculated from the composition of carbonic acid is therein put 54. Evidently Dalton about this period generally used whole numbers for his atomic weights; on this one occasion he showed more confidence than usual in the analytical figures from which he had deduced this atomic weight. An illustration of his attitude of mind at the time is to be found in the third laboratory note-book, page 76 (*circa* 1809), where he writes, in reference to the atomic weight of nitrogen, "From the above observations it seems probable that the true ratio of hydrogen to azote in ammonia is nearly 1 to 5, or perhaps 1 to $4\frac{3}{4}$; but as an integer is more easily remembered, we shall prefer the ratio 1 to 5 till a more accurate one can be ascertained."

There seems therefore to be little doubt that this sheet was prepared at the latter end of 1806 or early in 1807 for illustrating the lectures in Scotland in April, 1807. It is therefore the second publicly presented list, so far as is known. It was probably prepared by Dalton's own hand.

The atomic weights from Dalton's note-books and publications of this period, starting from the earliest found (in 1803) are collected for comparison in Table I.

Sheet 2.

Plate IV.

This table of atomic symbols and weights is much later than the previous one and is not very different from the corresponding list of elements in Volume II. of the "New System" (1827). The symbols are represented in the book by the full names of the elements. The following comparison shows those details where differences between the two lists are found:

TABLE I.

Iron	40	Sheet (Plate I).	Note-book i, 248.	...	Note-book i, 258.	...	Note-book i, 260.	...	Note-book i, 381-2.	...	Note-book ii, 107.	Mem. 6, 287.	Note-book ii, 284.	191 } 38? }	Note-book ii, 282.	331 } 66 }	29 or } 58 }	Note-book ii, 247.	Note-book ii, 255.	...	Note-book ii, 256.	Notes for lectures in Edinburgh and Glasgow.	Note-book ii, 421.	38	"New System" I, i.
Tin	22	22	36	70	50-60	
Lead	95	105	105	63	106 } 90 }	95	...	95	95	
Zinc	56	22	22	22	50+	52	56	...	56	56	
Bismuth	22	22	22	60	117±	62	
Antimony	32-44	37? 50? } 40 }	
Arsenic	25 } 50 }	40-48	42?
Manganese	16	16	56	58?	63

calculated from the composition of carbonic acid is therein put 5.4. Evidently Dalton about this period generally used whole numbers for his atomic weights; on this one occasion he showed more confidence than usual in the analytical figures from which he had deduced this atomic weight. An illustration of his attitude of mind at the time is to be found in the third laboratory note-book, page 76 (*circa* 1809), where he writes, in reference to the atomic weight of nitrogen, "From the above observations it seems probable that the true ratio of hydrogen to azote in ammonia is nearly 1 to 5, or perhaps 1 to $4\frac{3}{4}$; but as an integer is more easily remembered, we shall prefer the ratio 1 to 5 till a more accurate one can be ascertained."

There seems therefore to be little doubt that this sheet was prepared at the latter end of 1806 or early in 1807 for illustrating the lectures in Scotland in April, 1807. It is therefore the second publicly presented list, so far as is known. It was probably prepared by Dalton's own hand.

The atomic weights from Dalton's note-books and publications of this period, starting from the earliest found (in 1803) are collected for comparison in Table I.

Sheet 2.

Plate IV.

This table of atomic symbols and weights is much later than the previous one and is not very different from the corresponding list of elements in Volume II. of the "New System" (1827). The symbols are represented in the book by the full names of the elements. The following comparison shows those details where differences between the two lists are found:

TABLE I.

	The Lecture Sheet (Plate I).	6.9.1803.	19.9.1803.	9.1803.	3.1804.	14.9.1804.	1805.	14.8.1806.	23.8.1806.	16.9.1806.	9.1806.	22.10.1806.	Spring, 1807. Notes for lectures in Edinburgh and Glasgow.	7.1807.	1808.	1810.	2.5.1815.	1827.
		Note-book i., 248.	Note-book i., 258.	Note-book i., 260.	Note-book i., 381-2.	Note-book ii., 107.	Mem. 6, 287.	Note-book ii., 284.	Note-book ii., 282.	Note-book ii., 247.	Note-book ii., 255.	Note-book ii., 256.		Note-book ii., 421.	"New System" I., i.	"New System" I., ii.	Note-book vi., 227.	"New System" II.
Hydrogen ...	I	I	I	I	I	I	I	I	I	I	I	I	I	I	I	I	I	I
Oxygen	7	5'66	5'66	5 5	[5'5]	5'5	5'5	7	7	7	...	7	7	...	7	7	...	7
Azote	5	4	4	4	...	4 2	4'2	5	5	5	...	5	5	...	5	5	...	5 ± or 10?
Carbon	5'4	4'5	4'4	[4'3]	4'3	5	5	5	...	5	5'4	...	5	5'4	...	5'4
Sulphur	12	17	14'4	[14'4]	14'4	22	22 -	12	...	12	13	13	...	13, or 14
Phosphorus ...	9	...	7'2	7'2	9 $\frac{1}{3}$	9 +	9 $\frac{1}{3}$	9	9	...	9
Potash	12	18 ?	22 +	42	...	42	42	...	42	42
Soda	28	28	26, 28	28	...	28	28	...	28	28	...	28
Lime	23	22	22, 10?	23	...	23	23	...	23	24	...	24
Magnesia	20	20?	20 ±	20	...	20	20	...	20	17	...	17
Strontian	46	38 } 42 }	44?	46	...	46	46	...	46	46	...	46
Barytes	68	76?	48	68	...	68	68	...	68	68	...	68
Alumine	(11), 36?	30, 40, 60	11?	15	...	20
Gold	140	105	140	140-150	140	140?	90 } 45 }	60 ±
Platina	100	90-100	100	100?	90	73
Silver	100	105	63	...	115	100 ±	100 ±	...	100	100	100	90	90
Mercury	167	105	133 } 112 }	166	...	166	167	167	167	167 or } 84 } 56 or } 28 }
Copper	56	44	56	56	...	56	56	56	56	56
Iron	40	16	19? } 38? }	33? } 66 }	29 or } 58 }	...	40	...	50	38	50	50 } 25 }	25
Tin	22	36	70	50-60	...	50	52	52
Lead	95	105	63	...	106 } 90 }	...	95	...	95	95	95	90	90
Zinc	56	22	50 +	...	52	...	56	...	56	56	56	29	29
Bismuth	22	60	117 ±	62	...	68?	62	62
Antimony	32-44	37? } 50? } 40 }	...	40	40	40
Arsenic	25 } 50 }	40-48	42?	...	42?	21	21
Manganese	16	56	58?	63	...	40?	25	25

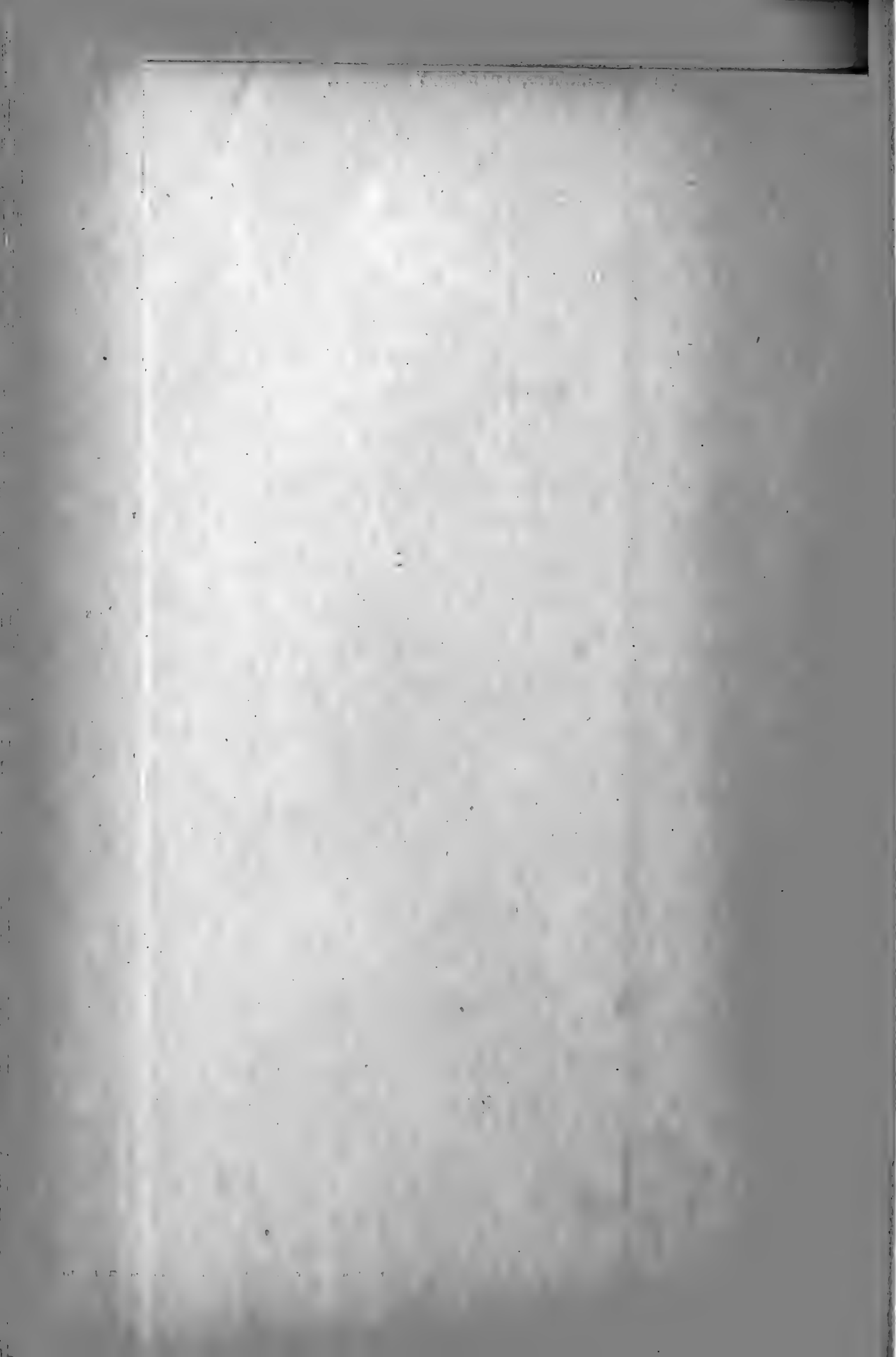

	"New System," II.	Sheet.
Azote	5±, or 10?	5
Sulphur	13, or 14	14
Gold	60±	56—63
Mercury	167, or 84?	167
Copper	56, or 28?	56
Tellurium	29, or 58?	28?—57?
Chromium	32	...25? 32? 39? 46?
Calcium... ..	17?	... }
Strontium	39	... } Not represented.
Barium	61	... }
Osmium	{ Neither name nor weight.	Symbol only, no weight.

It appears that the doubts entertained about the atomic weights of azote, sulphur, mercury and copper, at the time of compilation of the "New System," did not exist when the sheet was compiled; but on the other hand that the reverse is the case for chromium. The comparison of these figures therefore gives no clue as to which of the two lists is the earlier. It seems probable however that the sheet was made earlier than 1827, since calcium, strontium and barium find their place as elements in the book. The only apparent indication to the contrary is the presence of the element osmium on the sheet and not in the list in the book; but Dalton was quite aware of the existence of this element long before 1827, for an account of it appears in the "New System," I., p. 255. The reason that it did not appear in the list of elements in the book is that Dalton had no data for determining its atomic weight.

Sheet 3.

Plate VI.

Alternative formulæ for (a) water, (b) ammonia.

In the Edinburgh and Glasgow lecture notes (1807) Dalton refers to this or a similar diagram immediately after a discussion of the composition of water and ammonia: "See small scheme of three modes." In the

famous chapter "On chemical synthesis" in the "New System," I., i, 211—216 (1808), is found the following rule which led Dalton to choose the binary formulæ for these two compounds: "When only one combination of two bodies can be obtained, it must be presumed to be a *binary* one, unless some cause appear to the contrary." No "cause to the contrary" was ever admitted by Dalton for these formulæ.

Sheet 4.

Plate VI.

Alternative formulæ for the oxides of carbon,

Dalton chose the latter two formulæ to represent carbonic oxide and carbonic acid. A discussion of this question is found in the "New System," I., ii, 368—371.

Sheet 5.

Plate V.

"ATOMS OF ELASTIC FLUIDS."

These are represented as surrounded by atmospheres of heat of different sizes. They express Dalton's conception, at one time, of the composition and size of the atom of:

1. Hydrogen.
2. Hydrogen sulphide.
3. Nitrous oxide.
4. Carbon dioxide.
5. Water.
6. Hydrochloric acid ("Muriatic acid").
7. Methane ("Carburetted hydrogen from stagnant water").
8. Carbon monoxide.
9. Nitric oxide ("Nitrous gas").
10. Ammonia.
11. Nitric acid.
12. Alcohol.
13. Oxygen.
14. Nitrogen.
15. Ether.
16. Ethylene ("Olefiant gas").

This diagram obviously belongs to the very early days of the atomic theory, when to Dalton the atmosphere of heat around the atoms was still the fresh and vivid conception which had played so important a part in the physical origin of the atomic theory. The original sheet shows plainly that the formula for hydrogen sulphide (No. 2) is on a slip which has been pasted over an earlier formula representing that compound by a central sulphur atom surrounded by three atoms of hydrogen. The new formula was adopted in 1809 (Third laboratory note-book, page 185). The older one has been found in 1808 ("New System," I., i.), in 1807 (Edinburgh and Glasgow lecture-notes), and once as an alternative formula in 1806 (Laboratory note-book ii., p. 245, September, 1806). Before 1806 Dalton gave only the formulæ SH_2 and SH_4 . The original compilation of the sheet therefore belongs to the period 1806 to 1809.

Another formula of interest is that for muriatic acid, which is represented as HO_3 , a view held by Dalton in the "New System," I., ii. (1810).

Very interesting is the representation of methane, ethylene, ether and alcohol as hydrocarbons: CH_2 , CH , C_2H , and C_3H respectively. This is exactly the idea Dalton held at the time of the Edinburgh and Glasgow lectures (1807), as shown in the Mss. notes. It seems most likely that the table was prepared to illustrate those lectures, and is the actual "scheme" mentioned in the lecture notes for reference during the lectures.

A further point of interest is the difference between the mode of presentment in this early diagram and that employed in the "New System," I., ii. (1810). In the latter case (Plates 7 and 8) the atoms are represented by squares, each containing 16 rays representing the atmosphere of caloric.

In the early diagram the first eight atoms have nearly

the same diameter and the others follow in order of decreasing size. Slight differences exist between the values employed in this diagram and those given in the note-books and in the "New System," as is seen from the following list :

No. of figure in Diagram.	Diameter of the Atom.			
	On Diagram.	Note-book i., 258, 19 Sep., 1803. (Calculated to hydrogen unity)	Note-book ii., 107, 14 Sep., 1804.	'New System,' I. ii., 560. 1810.
1	1	1	1	1'000
2	1	1'143	—	1'00
3	1	0'971	0'952	0'947
4	1	1'048	1'00	1 00
5	1	1'009	0'976	—
6	1	—	—	1'12
7	1	—	1'00	1'00
8	1	1'05 +	0'993	1'020
9	0'95	0'981	0'958	0'980
10	0'95	0'971	0'965	0'909
11	0'85	0'905	0'854	—
12	0'87	—	0'911	—
13	0'80	0'810	0'787	0'794
14	0'78	0'762	0'758	0'747
15	0'75	0'667	0'652	—
16	0'80	0'952	0'809	0'81

Sheet 6.

Plate VI.

Formula, inscribed "Nitrous oxide, 13.9."

The atomic weights used were $N=4.2$, $O=5.5$. A reference to Table I. shows that these are later than September, 1803, and earlier than August, 1806. They actually appear in 1804 and 1805. The diagram is therefore of earlier date than the older of the atomic weight lists.

Sheet 7.

Plate VI.

Formula, inscribed "Carbonic acid, 15.3."

The atomic weights used were $C=4.3$, $O=5.5$. These belong to the same period as the atomic weights of the previous formula.

Sheet 8.

A similar formula for carbonic acid.

Sheet 9.

Plate VI.

Formula, inscribed "Carburetted hydrogen from stag. water, 6.3."

This again requires $C=4.3$ and is therefore of the same period as the formulæ for nitrous oxide and carbonic acid.

Sheet 10.

Plate VI.

Same formula as above for methane, together with a diagram apparently representing 3 atoms of hydrogen around a carbon atom.

The exact use Dalton made of this sheet is not clear.

Sheet 11.*Plate VI.*

Formula, inscribed "Ether, 10'4."

This requires $C = 4.7$, a value which we have not found elsewhere. The representation of ether as a hydrocarbon, C_2H , appears in the note-books of 1803 and 1805, and with doubt expressed in 1807.

Sheet 12.

Five oxides of nitrogen, represented as compounds of one atom of nitrogen with one, two, three, four and five atoms of oxygen respectively. It is improbable that Dalton himself ever adopted these formulæ for the oxides of nitrogen. The sheet was perhaps used to illustrate some contemporary views on the subject (*e.g.* T. Thomson, *Ann. Phil.* 1814, 3, 135, gives a list containing four of these oxides), or possibly even those of W. Higgins, "A Comparative View of the Phlogistic and Antiphlogistic Hypotheses," 132—5, 1789.

Sheet 13.

Five oxides of nitrogen, with names, as follows :

1 atom nitrogen + 1 atom oxygen.	...	"Nitrous gas."
2 atoms " 1 " "	...	"Nitrous oxide."
1 atom " 2 atoms "	...	"Nitrous acid."
2 atoms " 3 " "	...	"Subnitrous acid."
2 " " 5 " "	...	"Nitric acid."

This represents Dalton's view at the time of the publication of the second volume of the "New System" (1827). The same list is found in his paper in Thomson's *Ann. Phil.* 1817, 9, 186, and is much different from that expressing his opinions in 1810. The note-books (vi, 20, 40) show that the change in view occurred mainly in September or October, 1814.

Sheet 14.

Names and formulæ for some acids, with their weights.

In the modern symbols these are as follows :

CO ₂	Carbonic acid	19
SO ₃	Sulphuric acid	34
NO ₂	Nitric acid	19
NO ₃	Oxynitric acid	26
N ₂ O ₃	Nitrous acid	31
HO ₃	Muriatic acid	22
HO ₄	Oxymuriatic acid	29
PO ₂	Phosphoric acid	23
C ₂ H ₂ O ₂	Acetic acid	26

On the back of this sheet are the words, in Dalton's handwriting, "Old Chemical." The formulæ, names and weights correspond closely with those of 1810 ("New System," I., ii.), but are much different from those of 1827 ("New System," II., i.). The last line, relating to acetic acid, has been attached to the rest of the sheet by paste.

Sheet 15.

Symbols for sulphur, oxygen and hydrogen, and formulæ for some compounds formed by their union.

Using modern symbols, the list becomes :

SO	Sulphurous oxide.
SO ₂	Sulphurous acid.
SO ₃	Sulphuric acid.
HS	Sulphuretted hydrogen.

The first of these was supposed by Dalton to be produced as a bluish white substance, in admixture with yellow sulphur, when sulphurous acid and sulphuretted hydrogen are brought together. (See "New System," I., ii., 383 *et seq.*) It has proved to be in fact "milk of sulphur."

Sheet 16.

Formulæ and names for the following compounds of phosphorus :—

PO	Phosphorous acid.
P ₂ O	Subphosphorous acid.
PO ₂	Phosphoric acid.
PH	Phosphuretted hydrogen.

These are later than 1810, for in that year phosphorous acid was represented as P₂O₂ ("New System," I., i., plate 5), and subphosphorous acid was unknown.

Sheet 17.

Formulæ, only, for the sulphate, carbonate and oxide of barium.

Sheet 18.

Formulæ, only, for the oxides and sulphides of gold, mercury, iron, lead and arsenic, described in "New System," II.

Sheet 19.

Formulæ, only, for some compounds formed of two or more of the elements lead, arsenic, iron, sulphur, oxygen and hydrogen.

Sheet 20.

Formulæ for prussic acid [HC₂N₂], cyanogen [CN], ferrous oxide [FeO] and potash [KO].

Sheet 21.

Formula, with inscription "Acetic acid wt. 26 [? 25]."

Acetic acid is represented by symbols equivalent to C₂H₂O₂.

Sheet 22.

Same formula as on sheet 21.

This representation of acetic acid first appeared in 1806, in Note-book ii., 262. It appeared also in 1811 and in 1823; other formulæ were also used during this period.

Sheet 23.

On one side of this sheet are formulæ for ether and alcohol, which with modern symbols become C_4H_5O and C_2H_3O . They are inscribed:

Ether. wt.	34.
Oxy.	45.5
Carb.	35
Hyd ⁿ .	19.5
	100

Alcohol. wt.	21.
Oxy.	33.7
Carb.	52
Hyd ⁿ .	14.3
	100

These formulæ are evidently more recent than those on sheet 5, where these compounds are represented as CH and C_3H respectively. Dalton considered quite a number of different formulæ for these compounds between 1805 and 1810; they were mostly deduced from explosion experiments with the vapours of these substances. It is not until 1819 that some formulæ nearly like those of this sheet are found in the note-books (Note-book vii., 447). In lecture note-books dated 1824 and 1827 the molecular compositions are recognised as equivalent to C_4H_5O and C_2H_3O , and expressed as

1 atom water and 4 atoms olefiant gas, for ether,
and 1 atom water and 2 atoms olefiant gas, for alcohol.
 These formulæ would have contained the same numbers

of atoms of each of the elements as the modern formulæ, had Dalton used double atomic weights for oxygen and carbon.

Sheet 23 (reverse side).

Plate VII.

The atoms C_2H_2ON are arranged in two different ways to represent albumen and gelatine respectively, and under them is written :—

Expt. Albumen.	Theory.	Expt. Gelatine.
53 Carbone	44 Carbone	48 Carbone
27 Water	32 Water	31 Water
20 Ammon.	24 Ammonia	21 Ammon.
<hr style="width: 50%; margin: 0 auto;"/> 100	<hr style="width: 50%; margin: 0 auto;"/> 100	<hr style="width: 50%; margin: 0 auto;"/> 100

These formulæ are truly isomeric. It is also interesting to note the little respect Dalton shows for the analytical results, since he is satisfied that there is sufficient accordance between the experimental figures and the calculated ones.

The origin of these figures is found by reference to the Laboratory Note-book iv., p. 59, which shows Gay Lussac's analytical figures for albumen and gelatine as nearly the above, viz. :—

ALBUMEN.				GELATINE.			
			Gay Lussac.				Gay Lussac.
1 oxy.	7	23·3	23·9	1 oxy.	7	$28\frac{1}{4}$	27·2
3 carb.	16·2	52·6	52·9	2 carb.	10·8	$43\frac{1}{2}$	47·9
2 hyd.	2	6·6	7·5	2 hyd.	2	8	7·9
1 azote	5	16·5	15·7	1 azote	5	$20\frac{1}{4}$	17
	<hr style="width: 50%; margin: 0 auto;"/>	<hr style="width: 50%; margin: 0 auto;"/>	<hr style="width: 50%; margin: 0 auto;"/>		<hr style="width: 50%; margin: 0 auto;"/>	<hr style="width: 50%; margin: 0 auto;"/>	<hr style="width: 50%; margin: 0 auto;"/>
	30·2	100	100		100	100	100
or 1 Am.				1 Am.			
1 Water.				1 Wat.			
3 Carbone.				2 Carb.			

The formula for albumen in the Note-book is different from that of gelatine by possessing one atom of carbon more. The date in the Note-book is October, 1811.

Sheet 24.

Plate VII.

The formulæ for four organic acids, inscribed "oxalic," "citric," "acetic," "tartaric." Oxalic acid is represented as C_2O_3 , a compound of CO and CO_2 . Acetic acid is CHO, and citric and tartaric acids are represented as each having a central atom of oxygen, surrounded in the case of citric acid with three of these CHO groups symmetrically placed; in the case of tartaric acid with four of these CHO groups. In 1811 Dalton had the idea of an important part played by the CHO group, which he called the "vegetable atom" (Note-book iv., 56), with a weight 13.4. This idea might have been fruitful at the time: with modern atomic weights the grouping would have become CH_2O , which, as formaldehyde, seems to play a most important part in natural organic syntheses. Dalton published very little of his organic chemical work, however; indeed, it extended only occasionally beyond analyses of a few organic acids and their salts.

An exact reproduction of the formulæ for citric and tartaric acids has been found once only, in a note-book entitled, "Salts, Oxides, Sulphurets," which contains a laborious compilation of the composition by weight and the atomic composition of many of the compounds of metals. This note-book received additions during many years, and was probably intended to form a basis of volume II. of the "New System," not only the published part but also another projected part dealing with the salts of the metals. The formulæ of citric acid and tartaric acid in the note-book and on the sheet probably belong

to the period 1810 to 1815. The formulæ for acetic acid and oxalic acid occur frequently during many years, together with some others suggested but soon discarded.

Sheet 25.

Oxalic acid, again represented by symbols equivalent to C_2O_3 . On the back: "2 atoms with 90° asunder both oxygen and charcoal." "1 atom oxygen with 1 hole."

Sheet 26.

Citric acid, represented as CHO. On the back: " 60° asunder." This formulation has been found in the laboratory notes of 1841, and at the end of the pamphlet "A New and Easy Method of Analysing Sugar," a product of Dalton's last years, date about 1840.

Sheet 27.

"Acetic acid," erased.

"5 carbone 37
4 wat. 48."

Formula representing this acid by a central *carbon* atom with four "vegetable atoms" symmetrically disposed around it. This formulation for acetic acid is described at the end of the pamphlet, "A New and Easy Method of Analysing Sugar."

Sheet 28.

"Tartaric acid," erased, and replaced by "acetic acid."

Formula representing a central *carbon* atom with five "vegetable atoms" symmetrically disposed around it. On the back:

" $\frac{360}{5} = 72^\circ$ asunder."

"each peg . . . rest is obvious."

Tartaric acid is represented in the pamphlet mentioned

above as similarly constituted, but with six vegetable atoms.

Sheets 25 to 28 seem to belong to the same period and were found together, apart from all the other sheets described here.

Sheet 29.

Formulae equivalent to CHO (acetic acid, or "vegetable atom") and $C_4H_3O_3$, the latter being a central carbon atom surrounded by three "vegetable atoms." This may represent one of the acids above mentioned, or possibly the atom of sugar, or of wood. Dalton represented sugar on various occasions as a central carbon atom with 5, 8, and 12 "vegetable atoms" around it.

Sheet 30.

Formula, entitled "indigo." Equivalent to C_8H_2ON . In his paper on the "Nature and Properties of Indigo" (*Mem.*, 1824, 9, 427) Dalton arrived at this composition from Crum's analysis, with Dalton's own atomic weights.

Sheet 31.

Formula, entitled "oil etc." and described:

		Gay Lussac.	
"Carb.	77.7	77.2	"Olive oil and probably Spermaceti oil."
"Oxy.	9.2	9.4	"Constitution
"Hyd.	13.1	13.4"	1 atom Carbonic oxide.
			10 atoms olefiant gas."

This constitution is found in the Laboratory Notebook iv., p. 58 (1811). Earlier suggested formulae are to be found, but are different from that of this sheet.

Sheet 32.

The atoms C_3H_2ON arranged as a molecule. Below is written in Dalton's handwriting:

" Carb.	...	53·66
Oxyg.	...	23·16
Azote	...	16·56
Hydr.	...	6·62
		<hr/>
		100

Gay Lussac.	Carb.	Oxy.	Azot.	Hydr.	
Fibrin	...	53·36	19·87	19·93	7·02
Albumen	...	52·88	23·87	15·71	7·54
Cheese	...	59·78	11·41	21·38	7·43
Gelatine	...	47·88	27·21	17	7·91"

Further, a formula equivalent to C_2O is written below, and entitled "Tan. 18."

These analyses are also quoted in Note-book iv., 58 and 59, but the four bodies are therein supposed to have the following atomic constitutions:

	Carbon.	Oxygen.	Nitrogen.	Hydrogen.	
Fibrin	...	4	1	2	3
Albumen	...	3	1	1	2
Cheese	...	7	1	3	5
Gelatine	...	2	1	1	2

The formula for "tan" has been found in a lecture note-book on Pharmaceutical Chemistry, dated 1824, and in lecture-notes of 1827, and on the sheet of "atomic symbols" prepared to illustrate a lecture at the Manchester Mechanics' Institution in 1835.

Sheet 33.

Formula equivalent to $C_3H_2O_2$, with inscription "Wood."

	Gay Lussac.	Theory.
Carbone	52 ...	$50\frac{1}{2}$
Oxygene	42 ...	$43\frac{1}{4}$
Hydrogen	6 ...	$6\frac{1}{4}$
<hr/>		<hr/>
	100	100

The same formulation is found in Laboratory Notebook iv., 57 (1811), with Gay Lussac's figures for comparison.

Chemical Reactions represented by Formulæ.

Sheet 34.

Plate VII.

Reduction of a mercuric salt to a mercurous salt. Above the line is represented a mercuric salt ("A" is frequently used in the note-books to designate generically an acid). Below the line are represented two molecules of the corresponding mercurous salt formed from the mercuric compound by interaction with an atom of mercury.

This sheet may well have been prepared to illustrate the Edinburgh and Glasgow lectures of 1807, in the notes for which appears the following :

"Muriat Mercury 1 A + 1 protoxide M (black)

Oxymuriat M. }
or Corros. subl. } 2 A + 1 deutoxid M (red)

hence the reason why crude Merc. & cor. sub.
produce calomel or muriate of M."

Sheet 35.

Plate VII.

The combustion of methane. Represented by the formula for methane above the line, and below the line formulæ for one molecule of carbonic acid and two molecules of water.

These two diagrams are almost chemical equations. Dalton has not employed equations to any great extent ; one of the earliest is in the first laboratory note-book, page 278, August, 1804, and is reproduced in Roscoe and Harden's "New View of the Origin of Dalton's Atomic Theory," p. 63.

Apparatus for gas analysis.

Sheet 36.

A Volta eudiometer with wires to form the spark gap. Also, a cylinder, apparently to hold the eudiometer tube. Also, a graduated tube, with the lower open end enlarged, for collecting and measuring gases and treating them with reagents.

The Volta eudiometer is described in "New System," I, i, 274. It was frequently employed by Dalton in his investigations on gases.

Three Diagrams representing Speculations on the Nature of Solutions of Gases in Water:

Sheet 37.

"Air in Water." Two diagrams, closely represented by the carefully drawn Plate 3 in *Mem.*, 1805, 6.

Under one diagram are the words "Oxygenous, Nitrous, etc., $\frac{1}{27}$ Density," and under the other "Azotic, hydrogenous, etc., $\frac{1}{64}$ Density."

Sheet 38.

Two diagrams, similar to those on sheet 37. Inscribed "Hydrogenous, Azotic, and Carbonic oxide Gasses" and "Olefiant Gas in Water."

Sheet 39.

Two diagrams, similar to the above, inscribed

"Oxygenous, Nitrous and Carburetted Hydrogen Gasses."

[FIG.]

"Oxygenous gas, etc., in water."

N.B. Distance of the true atmosphere only $\frac{1}{3}$ of what it ought to be.

"Carbonic Acid, Sulphuretted Hydrogen, and Nitrous Oxide."

[FIG.]

"Carbonic Acid Gas, etc., in Water."

Sheets 38 and 39 are very early ; the spellings "hydrogenous" and "hidrogen" and "gasses" were discarded by Dalton before 1803.

Fourteen Diagrams representing the Arrangements of Atoms, in some cases with Atmospheres of Heat surrounding them.

Sheet 40.

Four atoms with their atmospheres of heat in contact. Each atom with its atmosphere occupies a square.

Sheet 41.

Plate VIII.

Four atoms with their atmospheres of heat.

Sheet 42.

Atmosphere of heat around two sets of four atoms.

Sheet 43.

Plate VIII.

The mutual repulsion of the atmospheres of heat round two atoms, represented to show a diminishing repulsion with increasing distance. This diagram may be the one referred to by Dalton in the note-book of the Birmingham lectures of 1817, as follows:—

"Repulsion of atoms inversely as the Distance.

Fact that condensation is as pressure—1. Tube expt.

2. Diagram * * * * *
* * * * *

Sheet 44.

Inscribed "Fluids"—(a) "elastic," (b) "inelastic."

(a) Represents gaseous atoms with their atmospheres of heat.

(b) Represents the closely packed atoms of a liquid or solid, without atmospheres of heat.

Sheet 45.

"Atoms" of steam repellent by virtue of their atmospheres of heat, above the close-packed atoms of water without heat.

Sheet 46.

Plate VIII.

"Heat in an atmosphere and in a vacuum."

A reference to "heat in a vacuum" is found in Dalton's "New System," I, i, 73 (1808): ". . . . interstitial heat amongst the small globular molecules of air, . . . [which] scarcely can be said to belong to them, because it is equally found in a vacuum or space devoid of air, as is proved by the increase of temperature upon admitting air into a vacuum."

Sheet 47.

Six atoms, four of one size, two of another, with their atmospheres of heat. These are figured similarly in "New System," I, ii., Plate 7.

Sheet 48.

In three equal areas are disposed atoms of hydrogen, nitrous oxide and carbonic acid. A similar diagram is in "New System," I, ii., Plate 7, but whereas in the book equal numbers of atoms of all three gases are present, in the sheet the numbers are in the ratio 9 : 7 : 7.

Sheet 49.

Entitled "Compound Atmosphere." There is a uniform distribution of "atoms" of nitrogen, oxygen, water

and carbonic acid, much as in the plate accompanying the memoir "On the Constitution of Mixed Gases" read in 1801 (*Mem.*, 1802, 5, ii., Plate 8). On this sheet the atoms are, in number,

315 of nitrogen
81 of oxygen
9 of aqueous vapour
7 of carbonic acid.

There is here a closer approach to the relative numbers of molecules of the constituent gases of the atmosphere, than in the memoir. The carbonic acid figure is too high, and the sheet was therefore compiled before Dalton's determination of the proportion of this gas in the atmosphere (*Mem.*, 1805, 6, 244. Paper read in 1802). The date of the diagram is therefore probably 1801 or 1802.

Sheet 50.

Fourteen atoms of nitric oxide are arranged regularly within a rectangle; in rectangles each exactly half the size are arranged separately fifteen atoms of nitrogen and fifteen of oxygen.

Sheet 51.

Spheres arranged as in "New System," I., i., Plate 3, figs. 1 and 2, to illustrate the arrangement of atoms of water and ice. The sheet differs from the figures in the plate only in the numbers of spheres, not in their arrangement.

Sheet 52.

Figures very like those of "New System," I., i., Plate 3, figs. 3, 4, 5, 6.

Sheet 53.

Plate VIII.

Figure similar to that of fig. 6 in the previous arrangement, which represents the hexagonal form of snow crystals as the result of the packing of atoms. One important difference exists : on the sheet, half the circles represent hydrogen atoms, half represent oxygen atoms ; in the book all the atoms are alike, and apparently each small circle represents an "atom" of water.







ELEMENTS



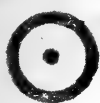

























	Wt.		Wt.
	1		46
	5		68
	5		38
	7		56
	9		56
	13		90
	20		190
	24		190
	28		190
	42		167

50

19" x 26 1/2"



	HYD. 1		CARB. 5.4		PHOS. 9
	AZOTE 5		OXYG. 7		SULP. 14

	56-63		26		37
	73		52		25
	90		90		25 ¹ 32 ¹ 39 ¹ 46 ¹
	167		29		50 ¹ - 100 ¹
	50		35		21 ¹ 32 ¹
	56		21		12 - 21
	42		62		59 ¹
			40		107 111
	56		22 - 57		22 ¹
	25		21		



ATOMS OF ELASTIC FLUIDS

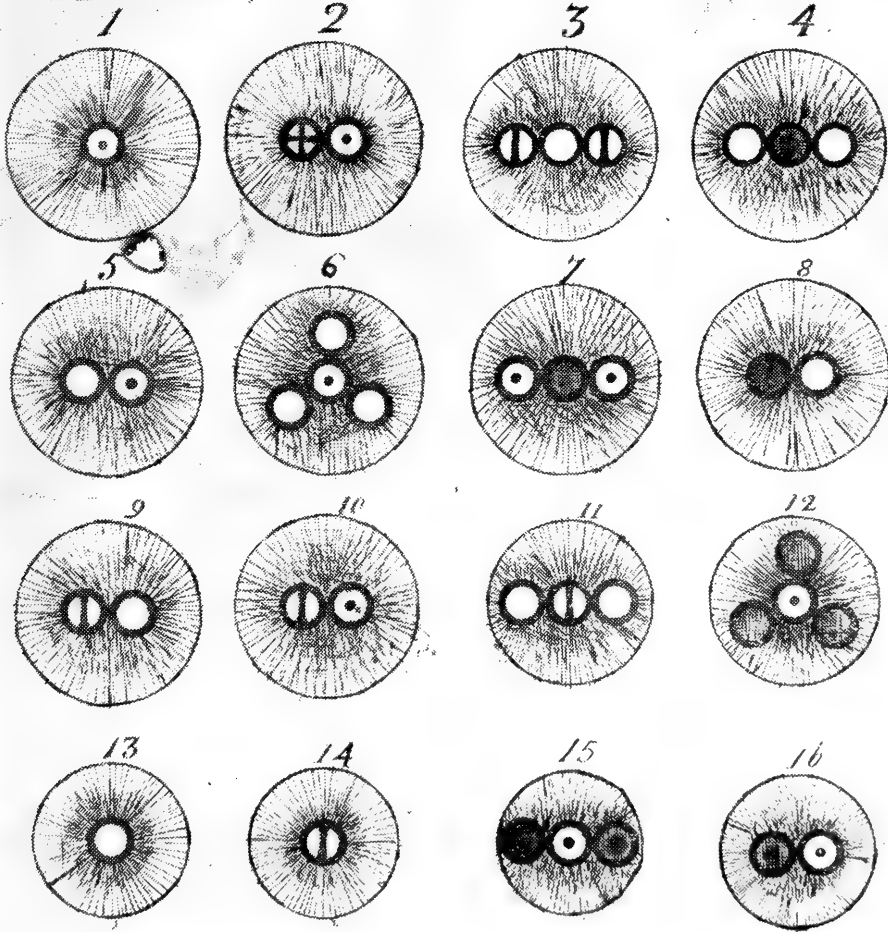

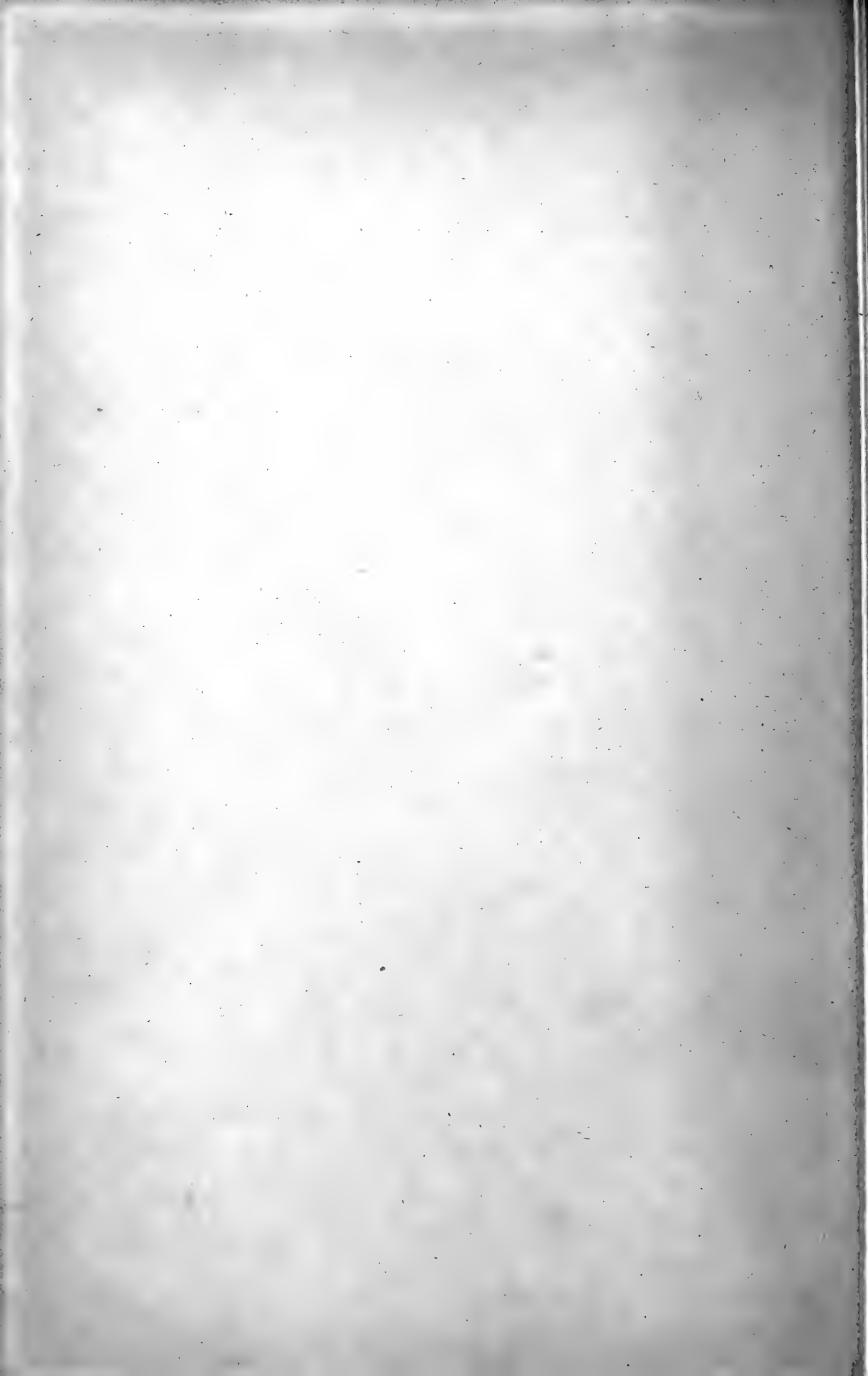

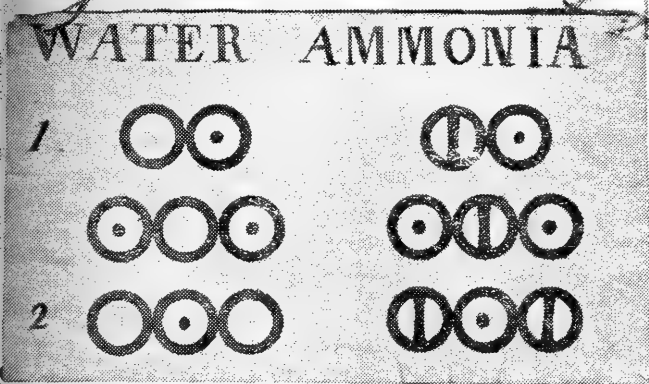

Sheet 3

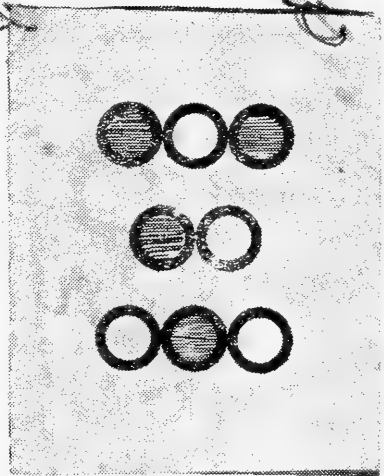

Sheet 4



Sheet 6

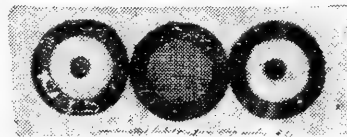

Sheet 9

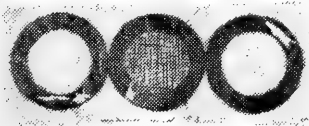

Sheet 7



Sheet 11

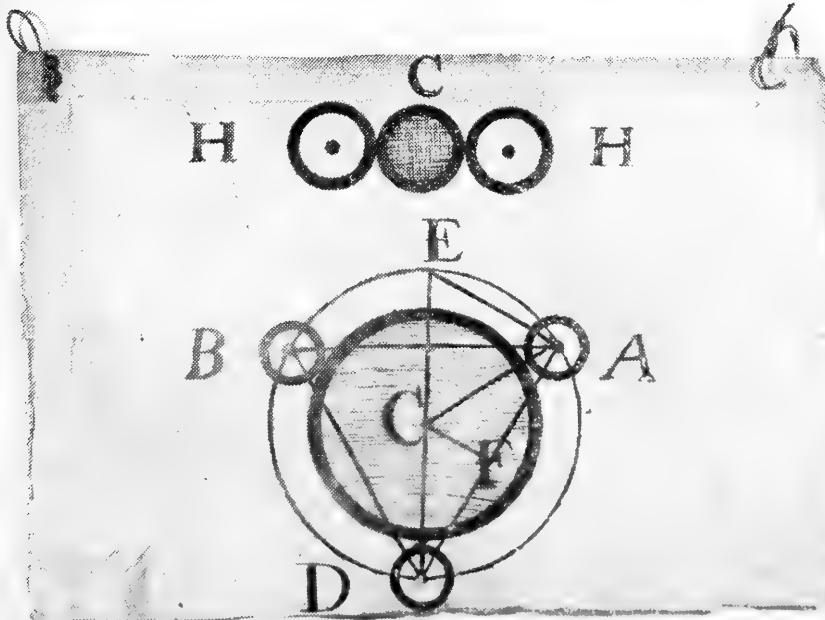

Sheet 10

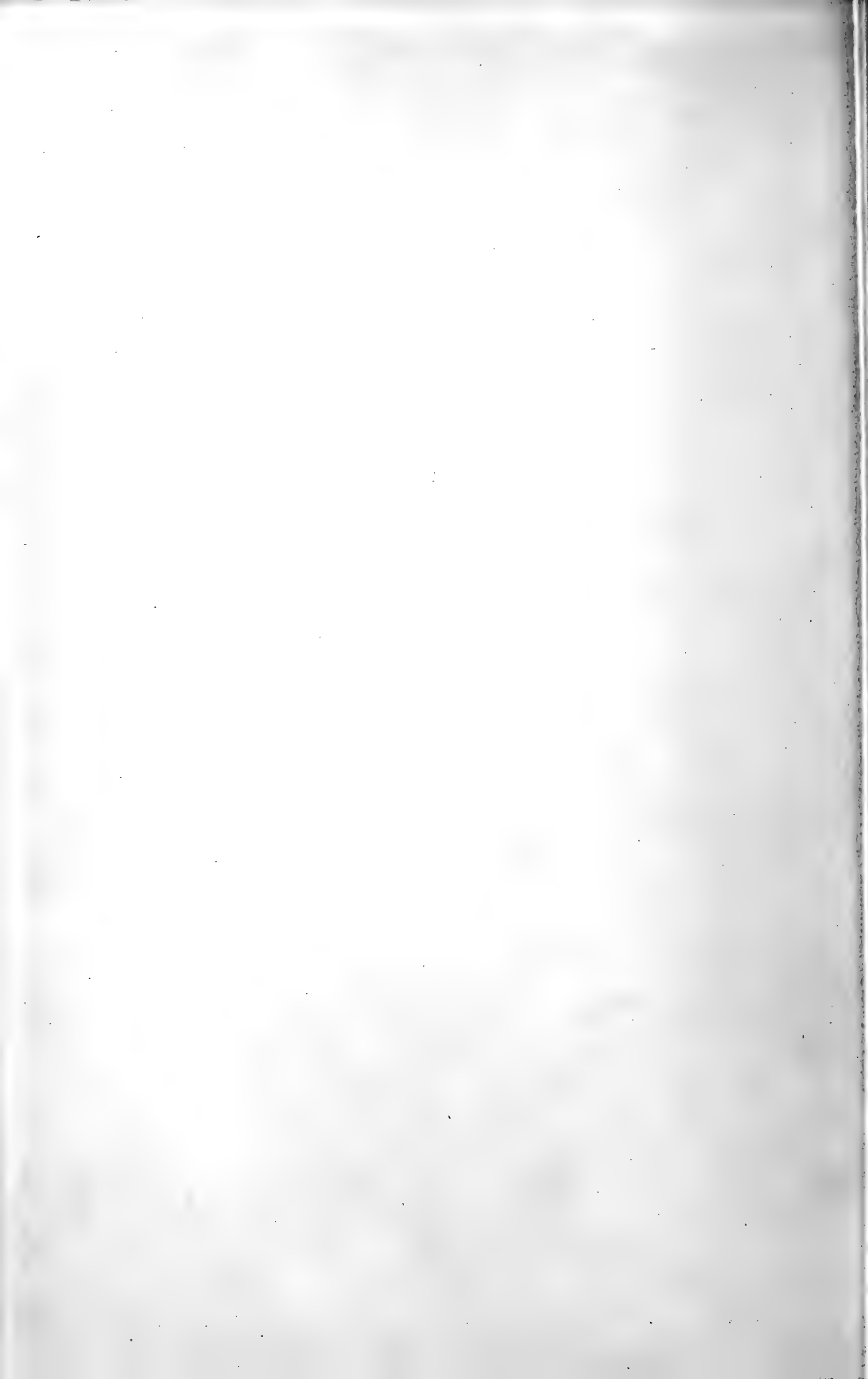

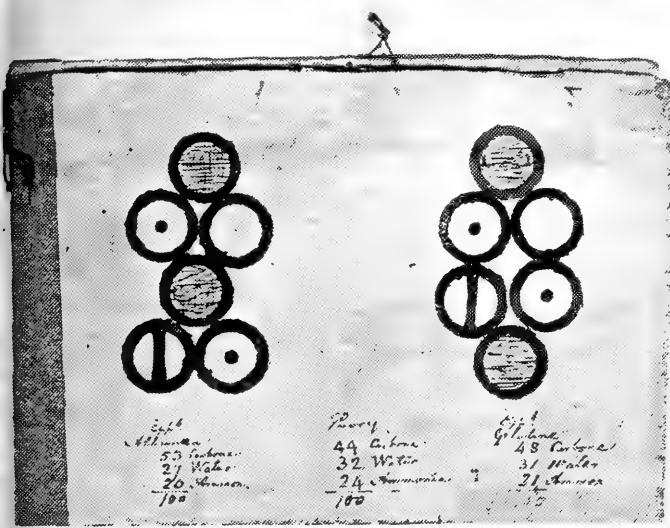

Sheet 23
 - reverse -

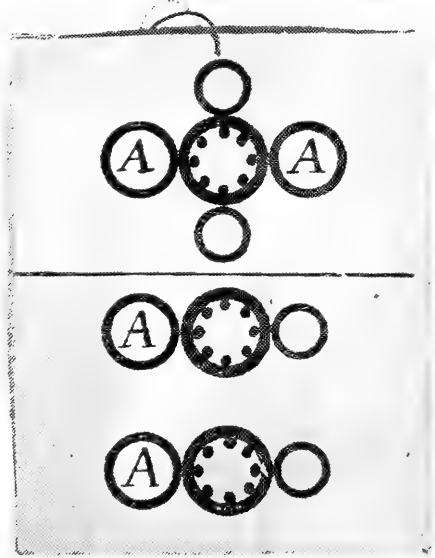

Sheet 34

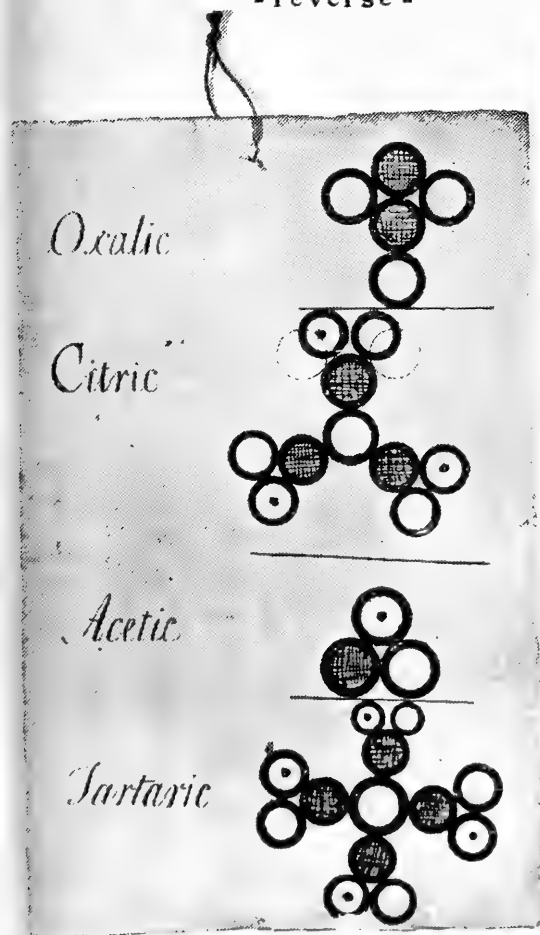

Sheet 24

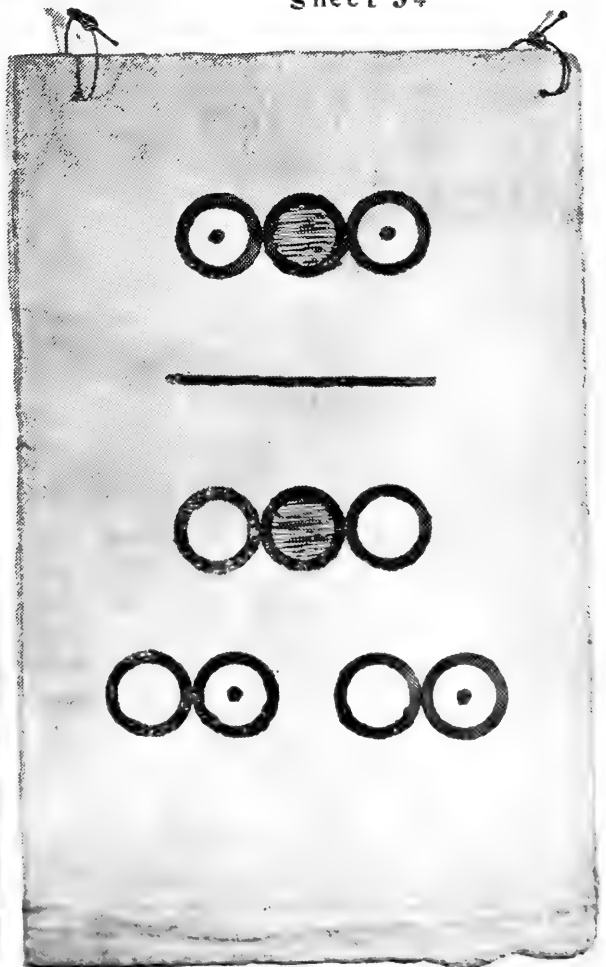

Sheet 35

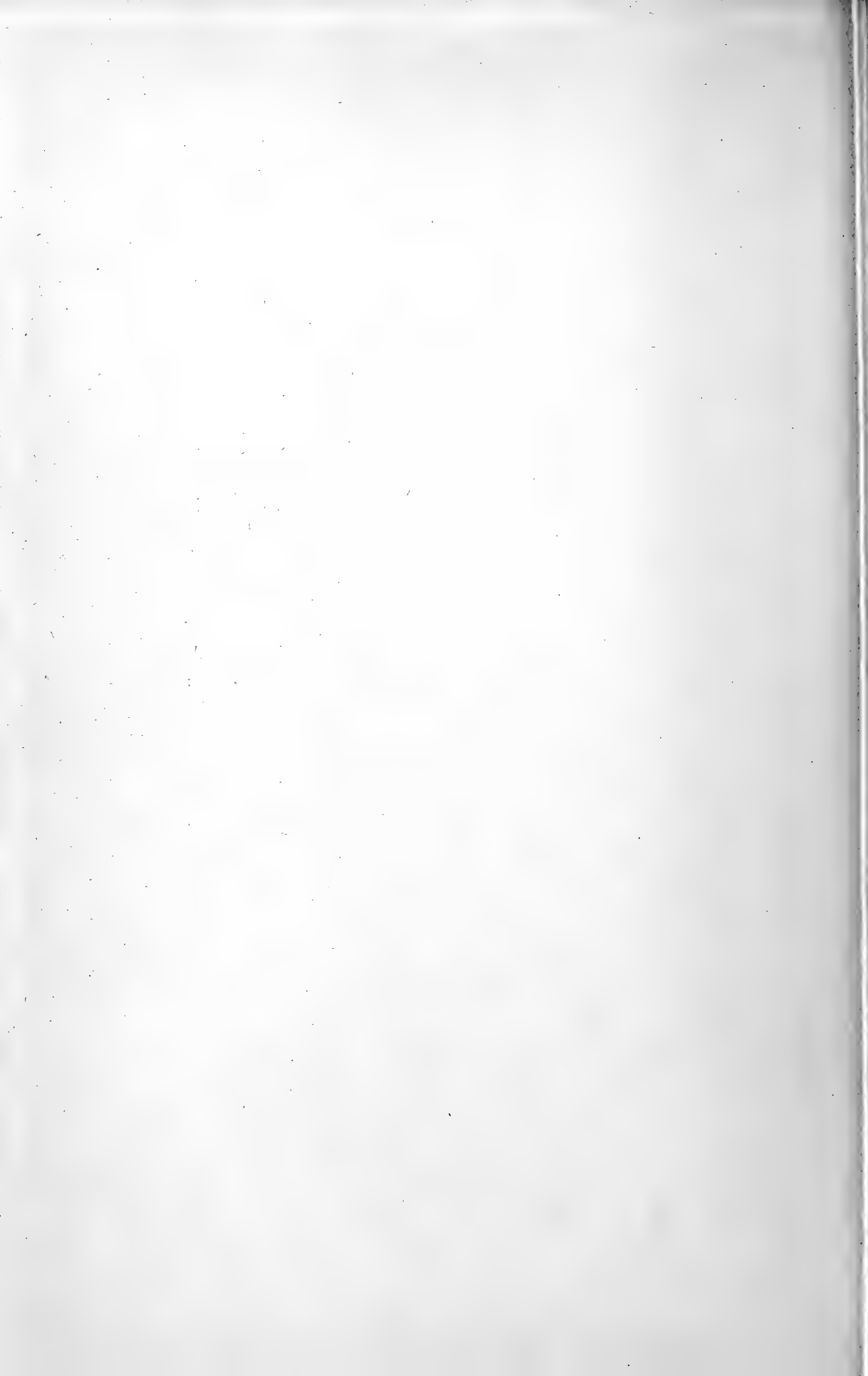

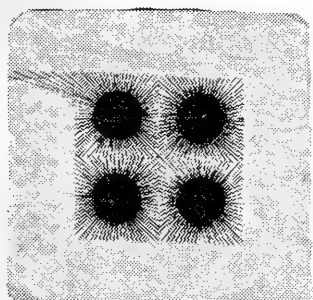

Sheet 41

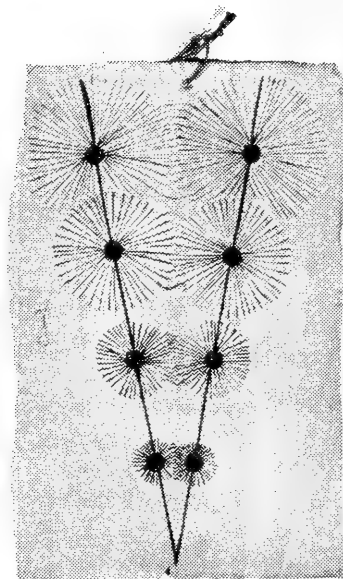

Sheet 43

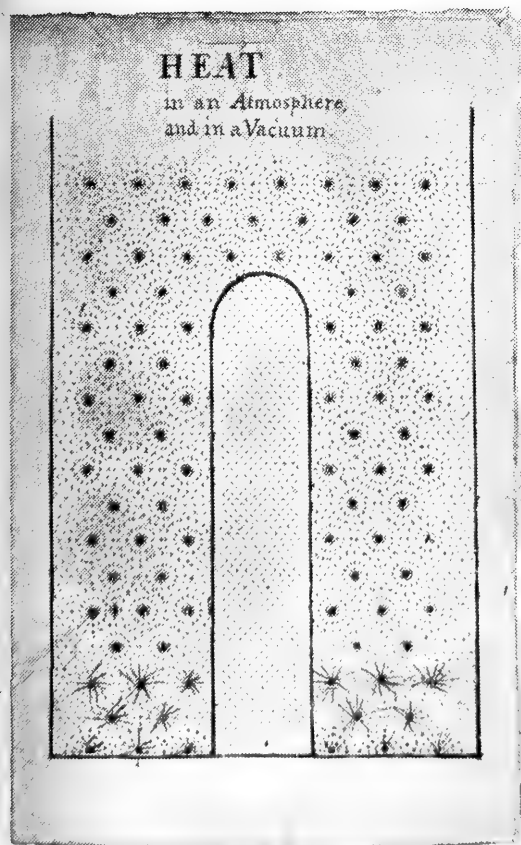

Sheet 46

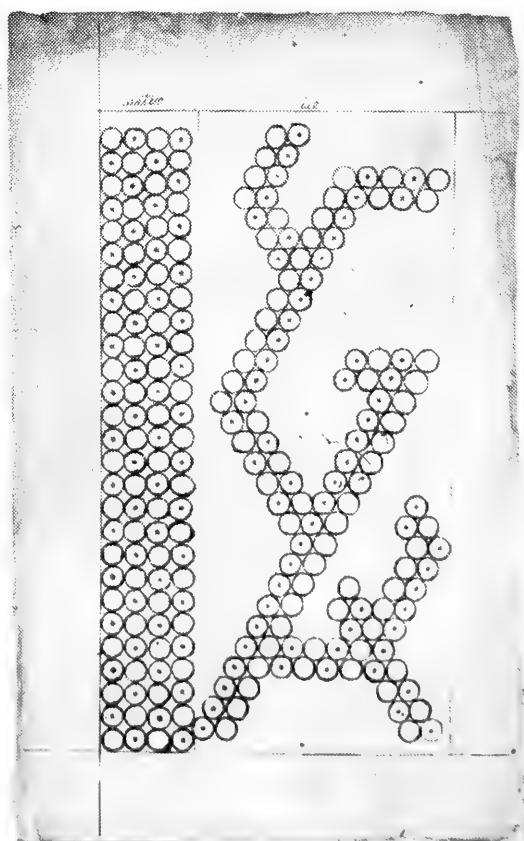

Sheet 53

Scale one-fifth.



XIII. Trisecting an Angle.

By Professor W. W. HALDANE GEE, B.Sc., M.Sc.Tech.,

AND

ARTHUR ADAMSON, M.Sc.Tech., A.R.C.S.

(*Read October 15th, 1912. Received for publication May 13th, 1915.*)

Introductory. The three famous problems whose solution was attempted by the early geometers relate to:—

1. Squaring the circle.
 2. Trisecting an angle.
- and 3. Duplicating a cube.

It was mainly through "a thousand attempts to solve these problems that new propositions and new processes were discovered and geometry made daily progress."¹ The first problem has recently been treated by Dr. E. W. Hobson.² Circle squarers are now rare, but during the last few years there has been quite a number of enthusiasts who have confidently declared that they had trisected an angle by the use only of a ruler and a pair of compasses. Some of these were brought directly under our notice, with the ultimate result that we decided that a useful purpose would be served by collecting together true or approximate solutions of the problem. As in the case of squaring the circle, the task opens up a little-studied field of Geometry abounding in interesting applications.

*The Method of Archimedes.*³ One of the ways of solving geometrical problems adopted by the Greek

¹ See J. Gow, "A Short History of Greek Mathematics."

² "Squaring the Circle: a History of the Problem." 1913.

³ Circa 287-212 B.C.

geometers is expressed by the word $\nu\epsilon\hat{\nu}\sigma\iota\varsigma$, which presents difficulties of exact translation. It has been rendered by *inclinatio* in Latin, and by *einschiebung* in German. This latter word signifies "putting in," "intercalation," or "interpolation," meanings only partly expressing what is implied by a $\nu\epsilon\hat{\nu}\sigma\iota\varsigma$, which requires the interpolation of a line in a diagram under special conditions, as is evident in the following construction that Archimedes used to solve the trisection problem.

Let ABC (Fig. 1) be the angle to be trisected. With B as centre and any radius BA , describe a circle. Produce CB to F , then from A draw a line AED so that the

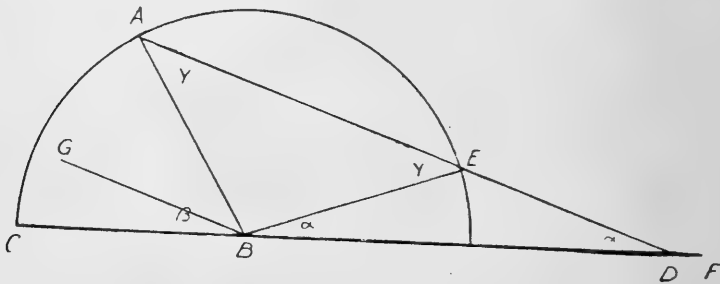

Fig. 1. Method of Archimedes.

intercept ED is equal to the radius of the circle. Here the $\nu\epsilon\hat{\nu}\sigma\iota\varsigma$ requires the interpolation of a line passing through a given point A and drawn so as to cut the circle in a point E that must satisfy the condition that ED is of the specified length. This can only be done by certain *indirect* methods as stated below. If we suppose the operation be accomplished, then—

$$\text{The angle } EBF = \frac{1}{3} \text{ the angle } ABC,$$

$$\text{or } \alpha = \frac{1}{3} \beta$$

$$\text{for } \gamma = 2\alpha \text{ and } \beta = \alpha + \gamma.$$

Hence BG drawn parallel to AD will be a trisector of the angle ABC .

The indirect methods referred to above may be classed as follows:—

Methods involving the use of loci other than the circle and straight line.

Trial methods, with or without the use of special measuring instruments.

Mechanical methods involving the use of a linkwork arrangement.

Approximate methods.

The application of these methods to the various solutions of the trisection problem will now be given in order.

USE OF LOCI.

I. *The Trisectrix of Maclaurin.*⁴

This curve is defined as the locus of a point P (*Fig. 2*), such that the angle PAC is three times the angle PBC , where A and B are fixed points and C lies on BA

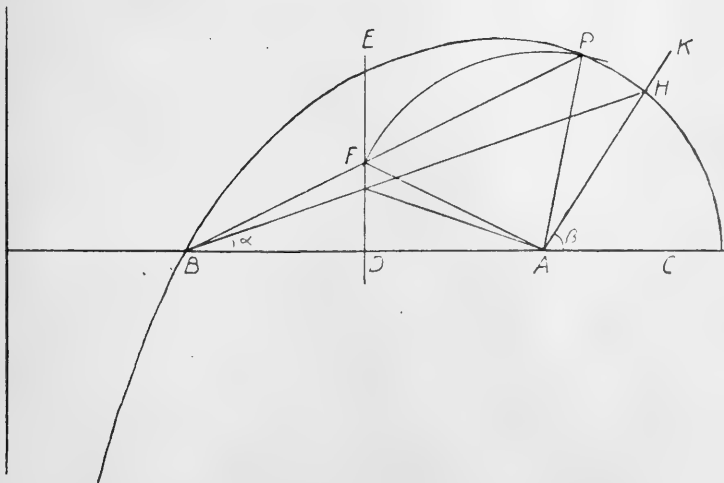

Fig. 2. Trisectrix of Maclaurin.

produced. The curve can easily be constructed as follows: Bisect AB at D . Draw DE perpendicular to BA . Through B draw any straight line intersecting DE at F .

⁴ F. Gomes Teixeira, *Proc. Edinburgh Math. Soc.*, Vol. 30, p. 96, 1911-12.

Join AF . With A as centre and AF as radius, describe a circle cutting BF at P . The locus of P is the curve required, since obviously the angle PAC is equal to three times the angle PBA .

If KAC , denoted by β , be the angle to be trisected, find H , the point where AK cuts the trisectrix. Join BH . Then the angle HBA (or a) is one-third of the angle KAC .

II. *Use of the Limaçon of Pascal.*⁵

Let A (*Fig. 3*) be a point on the circumference of a circle of which B is the centre. Through A draw any

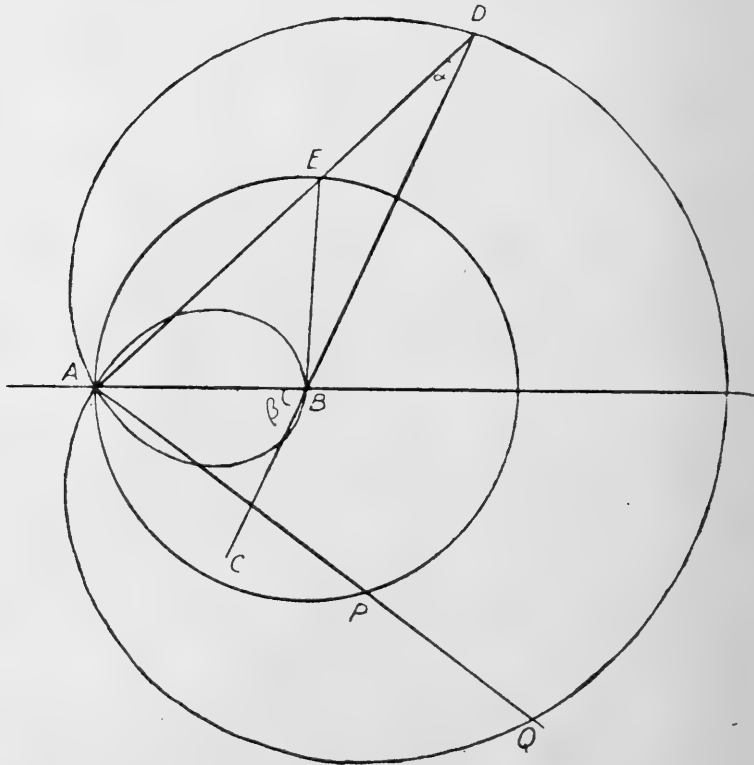

Fig. 3. Use of Limaçon.

straight line cutting the circle at P , and on this line mark off a length PQ equal to a constant length. The locus of Q is a limaçon curve. The special form of limaçon used for the trisection of angles is called the "trisectrix,"

⁵ 1623-1662.

and is obtained by using the radius AB as the constant length.

Let ABC (or β) be the angle to be trisected. Produce CB to meet the trisectrix at D . Join DA , cutting the circle at E . Then, since DE equals AB , the angle ADB , denoted by α , is one-third of the angle ABC .

On comparing *Fig. 3* with *Fig. 1* it will be apparent that this solves the $\nu\epsilon\upsilon\sigma\iota\varsigma$ of Archimedes.

III. Use of the Conchoid of Nicomedes.⁶

This curve is such that the straight line joining any point on the curve with a given point is cut by a given straight line so that the segment between the curve and the straight line is constant.

The conchoid has been used in several ways to solve the trisection problem.

Proclus states that Nicomedes, the inventor of the curve, applied it to trisect an angle, but Pappus claims this application. It is possible, however, that Archimedes himself used a curve of the nature of the conchoid, in order to solve the $\nu\epsilon\upsilon\sigma\iota\varsigma$ problem already mentioned.

The simplest application of the conchoid is as follows :

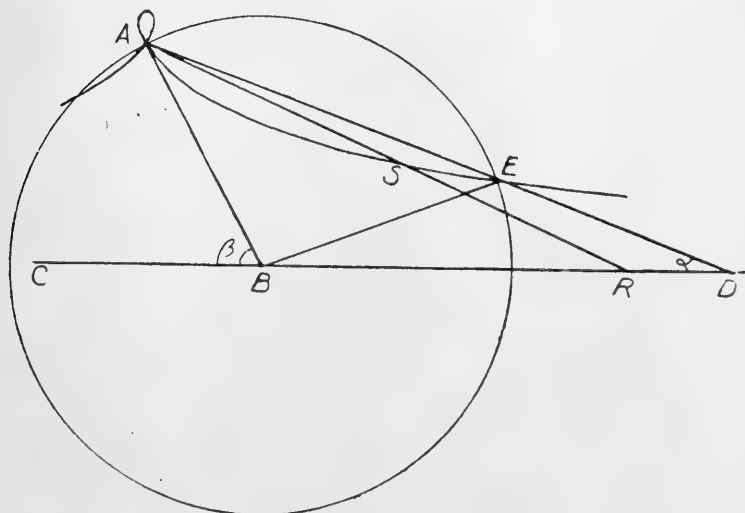

Fig. 4. Use of Conchoid.

⁶ Circa 180 B.C.

Let ABC (Fig. 4) be the angle β to be trisected. With B as centre and any radius BA describe a circle. Through A draw any straight line cutting CB at R . Join AR . On AR mark off RS equal to BA . Then the locus of S is the conchoid required, and E , its intersection with the circle, is the point through which AED must be drawn in order that the angle ADB , or α , shall be one-third of the angle ABC .

Pappus showed that any angle ABC (Figs. 5 and 6)

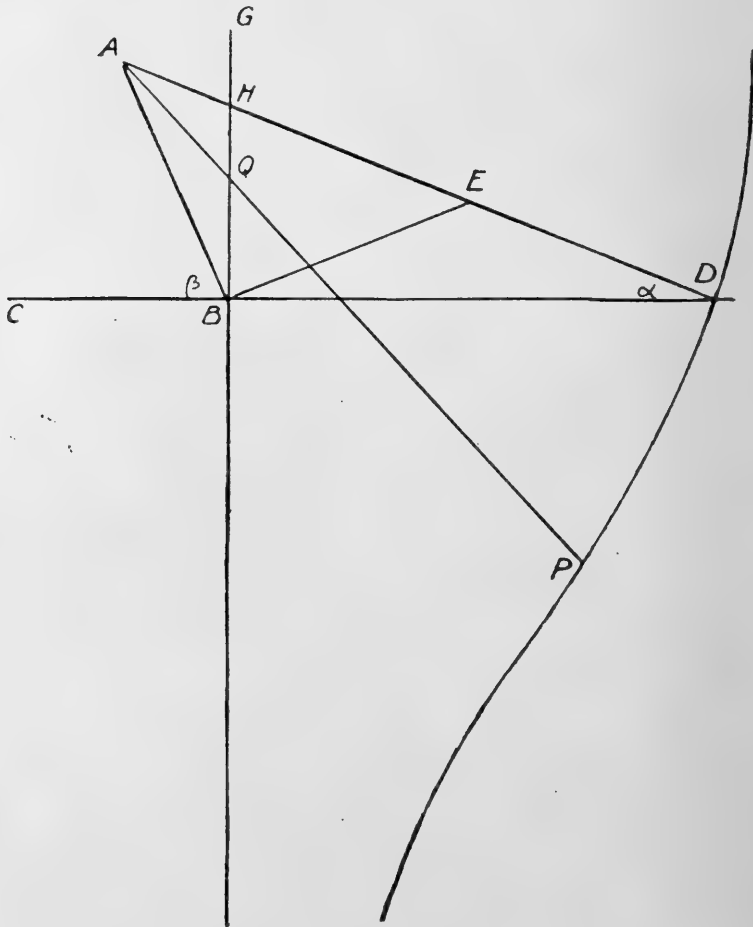

Fig. 5. Method of Pappus (Use of Conchoid).

could be trisected by solving the following $\nu\epsilon\delta\sigma\iota\varsigma$:
Through B draw BG perpendicular to BC , and through

A draw a straight line intersecting CB at D and BG at H , so that the intercept DH shall be equal to twice AB . This problem was solved by Pappus in two ways: (1) by using a conchoid, (2) by using a rectangular hyperbola. The conchoid used was the locus of a point P (Fig. 5) obtained by drawing any straight line through A intersecting BG at Q and making QP equal to a constant length equal to twice AB . The intersection of this conchoid with CB is the required point D , the angle ADB , or α , being one-third of the angle ABC . This becomes obvious if E , the middle point of DH , be joined to B .

The other method used by Pappus was to draw a rectangular hyperbola passing through B (Fig. 6) with

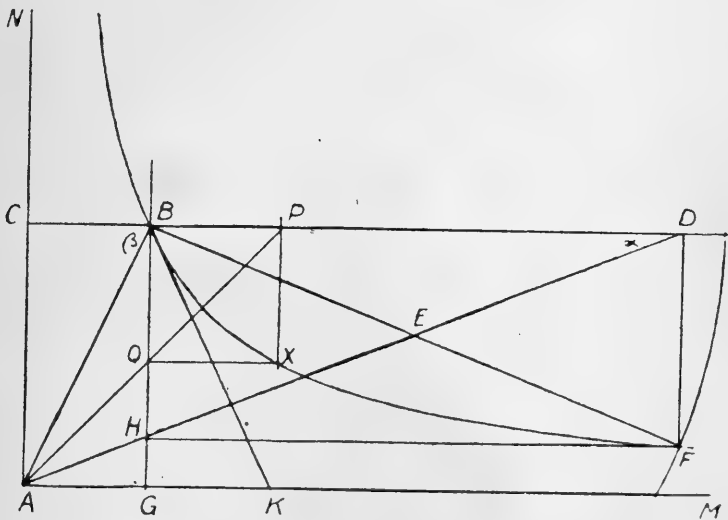

Fig. 6. Method of Pappus (Use of Hyperbola).

asymptotes AM and AN parallel to BC and BG respectively. This will be the locus of a point X where AQP is any straight line passing through A , and QX and PX are parallel to BC and BG . A circle with B as centre and radius twice AB intersects the hyperbola at F . By completing the rectangle $BHFD$ on BF as diagonal, the required points H and D are found, HD being equal to

BF or twice AB , and the angle ADB , or α , being equal to one-third of the angle ABC , or β .

In this figure AD is obviously one of the trisectors of the angle BAM , and also BF is one of the trisectors of an angle DBK made equal to the angle ABC .

IV. *General method by the intersection of a conic and a circle.*

In an article on "The Trisection of a Given Angle,"⁷ L. Crawford states that "the general problem is solved by considering the intersection of a conic with a circle, the conic to pass through four points in the circle, three being the angular points of an equilateral triangle. The general equation is satisfied by a rectangular hyperbola, also by a hyperbola of eccentricity two. Less simple constructions are also possible with parabola and ellipse."

Some of these methods will now be given.

(1) *Use of a rectangular hyperbola.*

The second method of Pappus already given is one example. Its agreement with Crawford's statement may be demonstrated by combining the equations of the curves. Let A (Fig. 6) be taken as origin with axis of x and y parallel to BC and BG ; then if $AG = a$ and $BG = b$, the equations of the hyperbola and the circle are:

$$xy = ab$$

and

$$(x - a)^2 + (y - b)^2 = 4(a^2 + b^2).$$

The ordinates of the four points of intersection are found by eliminating x and solving for y . One solution is $y = -b$, and this corresponds to the intersection on BA produced. The other three solutions are given by the cubic equation:

⁷ *Proc. Edinburgh Math. Soc.*, Vol. 16, p. 42.

OA for a diameter and passing through the point C of intersection of OB with the tangent AC to the circle at A , will pass through one of the two points of trisection of the arc. To draw this hyperbola: Bisect AC at D and OA at L . Join LD and produce to F , making DF and DE each equal to AD . Draw the rectangle $AFCE$. The asymptotes XX' , YY' , of the hyperbola will be parallel to AF and AE and intersect at L . Construct the hyperbola intersecting the circle at P as well as at A and at two other points, P_1 , P_2 , not shown in *Fig. 7*. Join OP , then the angle POB will be $\frac{1}{3}$ of the angle AOB .

Proof.—Construct the rectangle $PGOH$ on OP as diagonal with sides parallel to the asymptotes, and draw the diagonal GKH . Then, as in the construction of Pappus (*Fig. 6*):

$$\begin{aligned}\angle OLX &= \angle OLK + \angle XLK \\ &= \angle OKL + \angle POH \\ &= 3\angle POH.\end{aligned}$$

But

$$\angle COH = \angle FAC = \angle EAL = \angle GOL.$$

Therefore

$$\begin{aligned}3\angle POB &= 3\angle POH - 3\angle COH \\ &= \angle OLX - 3\angle COH \\ &= 90^\circ + \angle COH - 3\angle COH \\ &= 90^\circ - 2\angle COH \\ &= \angle AOB.\end{aligned}$$

Similar geometrical proofs could be given to show that the angles P_1OB and P_2OB are respectively equal to one-third of the angles $AOB + 2\pi$ and $AOB + 4\pi$, and that consequently P_1 , P_2 and P are the angular points of an equilateral triangle. These additional facts may also be proved analytically as follows:

Let

$$\angle AOH = \alpha, \quad OA = 2a.$$

Then if O be taken as pole and OH as initial line, the equation of the hyperbola is:

$$(r \cos \theta - a \cos a)(r \sin \theta - a \sin a) = a^2 \cos a \sin a.$$

Or

$$r^2 \cos \theta \sin \theta - ar \sin \theta \cos a - ar \cos \theta \sin a = 0.$$

Or

$$\frac{r}{2} \sin 2\theta = a \sin(\theta + a).$$

The intersections with the circle $r = 2a$ will satisfy the condition

$$\sin 2\theta = \sin(\theta + a).$$

Hence

$$2\theta = 2n\pi + \theta + a.$$

Or

$$2\theta = (2n + 1)\pi - (\theta + a),$$

where n is an integer or zero. The former solution gives the point A for the position of P . The second solution gives, for $n = 0, 1$ or 2 , three positions for P such that:

$$POH = \theta = \frac{\pi - a}{3}, \quad \frac{\pi - a}{3} + \frac{2\pi}{3}, \quad \frac{\pi - a}{3} + \frac{4\pi}{3},$$

and these three points are the angular points of an equilateral triangle. But it has been proved that if the angle OLX (that is, $\pi - a$) is three times the angle POH , the angle AOB must be three times the angle POB ; or in other words, if

$$\theta = \frac{\pi - a}{3},$$

then

$$\angle POB = \frac{1}{3}(\angle AOB).$$

Therefore the two angles POB with the remaining two positions of P , which are respectively $2\pi/3$ and $4\pi/3$ more than one-third of the angle AOB , must be equal to one-third of the angles $(AOB + 2\pi)$ and $(AOB + 4\pi)$ respectively.

Crawford gives a general consideration of the intersection of a conic with a circle, from which may be

deduced the proofs of the methods of trisecting an angle by means of a rectangular hyperbola. His methods, somewhat modified, are as follows:—

Let angle AOB (*Fig. 8*) = β and let $OA = d$. Take O

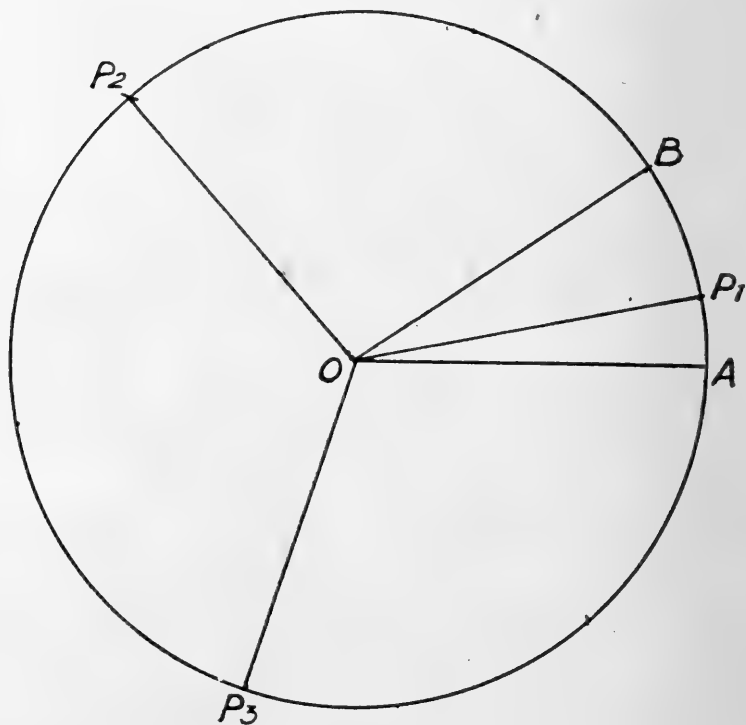

Fig. 8. Illustrating triple solution.

as origin and OB as axis of x .

The conic :

$$ax^2 + 2hxy + by^2 + 2gx + 2fy + e = 0.$$

will be a rectangular hyperbola if $a + b = 0$, and will have OA as a diameter if :

$$\frac{ad}{2} \cos \beta + \frac{hd}{2} \sin \beta + g = 0$$

and

$$\frac{hd}{2} \cos \beta - \frac{ad}{2} \sin \beta + f = 0.$$

The equation then becomes :

$$a(x^2 - y^2) + 2hxy - dx(h \sin \beta + a \cos \beta) - dy(h \cos \beta - a \sin \beta) = 0,$$

or in polar co-ordinates, taking O as pole and OB as initial line

$$ar \cos 2\theta + hd \sin 2\theta = dh \sin(\beta + \theta) + da \cos(\beta + \theta),$$

or

$$r \cos(2\theta - \phi) = d \cos(\beta + \theta - \phi), \text{ where } \tan \phi = h/a.$$

The points where the circle, $r = d$, cuts the hyperbola are given by

$$\cos(2\theta - \phi) = \cos(\beta + \theta - \phi), \text{ or } 2\theta - \phi = 2n\pi \pm (\beta + \theta - \phi),$$

where n is an integer or zero.

The plus sign gives

$$\theta = \beta + 2n\pi,$$

which corresponds to the point A .

The minus sign gives

$$\theta = \frac{2\phi - \beta}{3} + \frac{2n\pi}{3}.$$

Three points, P_1, P_2, P_3 , will satisfy this condition and are obtained by taking $n = 0, 1$ and 2 respectively. The triangle $P_1P_2P_3$ is equilateral.

The method of Chasles is now deduced by taking $\phi = \beta$, since then the angles AOP_1, AOP_2, AOP_3 will be one-third of the angles $AOB, AOB + 2\pi, AOB + 4\pi$ respectively, and if $\phi = \beta$ and $\theta = 0$ be substituted in the polar equation of the hyperbola, it follows that $r \cos \beta = d$, which is the condition that the hyperbola shall pass through the point where OB cuts the tangent to the circle at A (compare Fig. 7).

The method of Pappus is deduced by simply taking $\phi = \pi/2$.

(2) Use of a hyperbola of eccentricity two.

This curve may be used in a very simple manner to trisect a circular arc, and hence to trisect an angle. The following constructions, which only differ slightly, are given by Newton (*a*), Pappus (*b*) and Clairaut (*c*), and are restated in the "Mathematical Recreations" of W. W. Rouse Ball.

Method of Newton.—Let ABC (Fig. 9) be the angle to be trisected. On BC take any point E , and through E draw EM perpendicular to BC . Construct a hyperbola of eccentricity = 2, with EM as directrix and B as corresponding focus. Let F and H be the vertices, so that $BF = 2FE$ and $BH = 2HE$. Draw BO perpendicular to AB , meeting ME at O . With O as centre and OB or OH as radius, describe a circle cutting at P the branch of

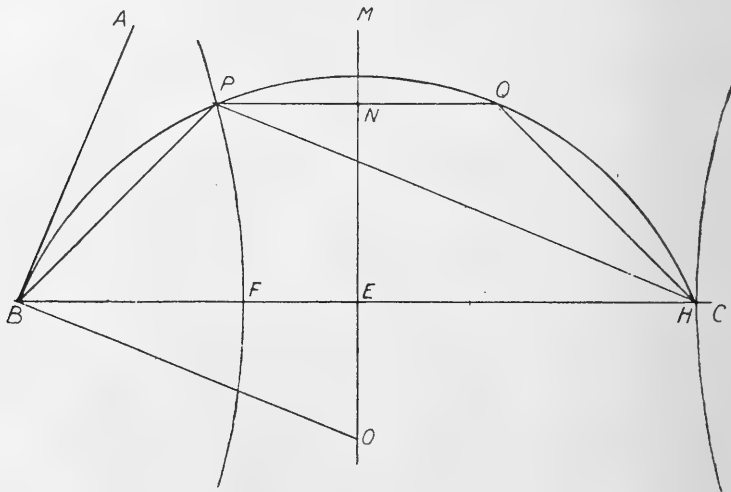

Fig. 9. Method of Sir I. Newton.

the hyperbola which passes through F . Join PB . Then the angle ABP will be one-third of the angle ABC . To prove this, draw PQ parallel to BH , intersecting ME at N . Join QH, PH . Then $PQ = 2PN = PB = QH$. Therefore the angle ABP , which is equal to the angle BHP , is equal to half the angle PBH and to one-third of the angle ABC .

Method of Pappus.—Let ABC (Fig. 10) be the angle to be trisected. As before (Fig. 9) construct the hyperbola and determine the point O . With O as centre and OB or OH as radius describe a segment of a circle cutting ME produced at S . Join SB, SH . With S as centre and SB or SH as radius describe a circle cutting at P

the branch of the hyperbola which passes through F .

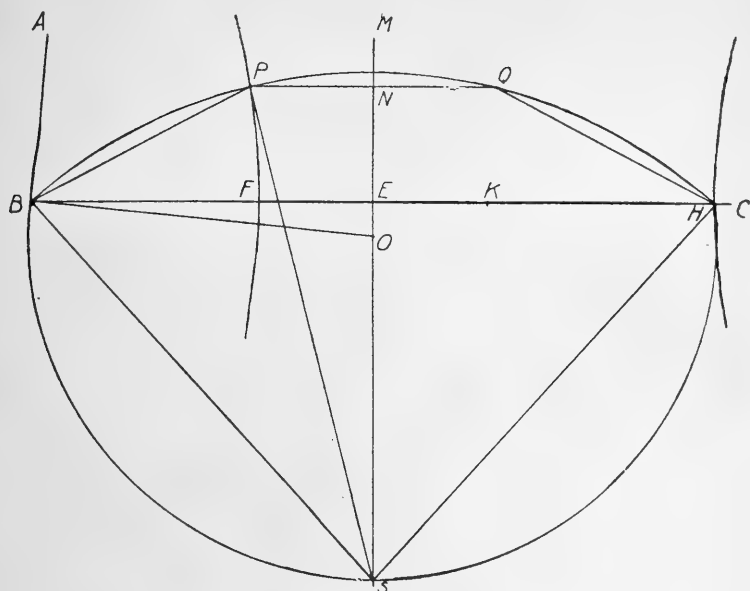

Fig. 10. Methods of Pappus and Clairaut.

Draw PQ parallel to BH cutting ME at N . Join BP , QH and SP .

Then, as before, the arcs BP , PQ and QH are equal. Therefore

$$\angle PBH = \frac{1}{2} \angle PSH = \angle BSP = \frac{1}{3} \angle BSH = \frac{1}{3} \angle ABC.$$

Method of Clairaut. This method is the most direct of the three. In Fig. 10 let BSH be the angle to be trisected. With S as centre describe a circle cutting off SB and SH . Join BH . Trisect BH at F and K . Bisect the angle BSH by SM , cutting BH at E . Construct a hyperbola of eccentricity = 2, with B as focus and SM as directrix, and let the branch which passes through F cut the circle at P . Join PS . Then the angle BSP is one-third of the angle BSH , as previously proved.

It can easily be shown that the circle with centre S cuts the hyperbola at H , P , and at two other points P_1, P_2 , such that PP_1P_2 is an equilateral triangle.

(3) *Use of a parabola.*

This method for trisecting an angle is given by Descartes and is re-stated in Ball's "Mathematical Recreations."

The parabola

$$y^2 = \frac{1}{4}x$$

and the circle

$$x^2 + y^2 - \frac{13}{4}x + 4ay = 0,$$

intersect at points whose ordinates satisfy the equation :

$$16y^4 + y^2 - 13y^2 + 4ay = 0,$$

or

$$16y^3 - 12y + 4a = 0,$$

or

$$a = 3y - 4y^3.$$

Hence if

$$a = \sin 3\alpha,$$

then

$$y = \sin \alpha$$

will satisfy the equation.

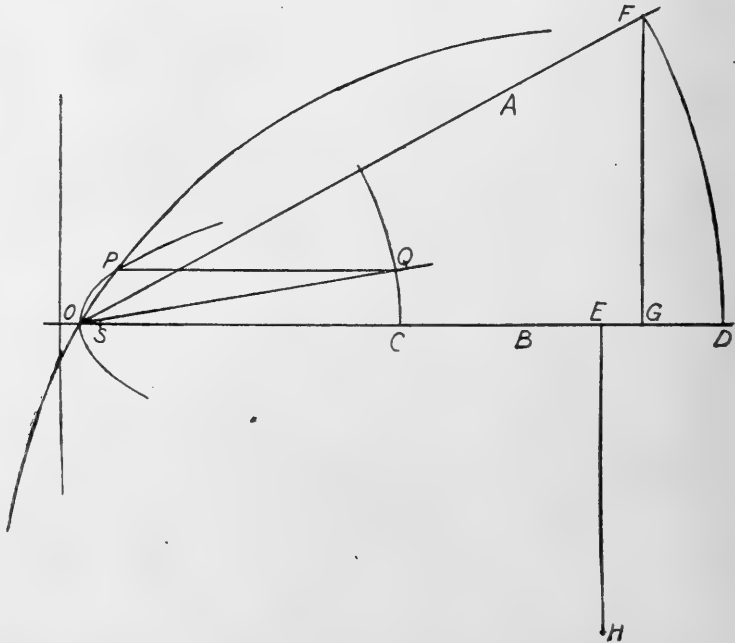

Fig. II. Use of Parabola.

Fig. 11 shows the method of construction. AOB is the angle to be trisected. O is the origin and OB the axis of x . OC is made unit length, $OF = OD = 2(OC) = 2$.

$$OS = \frac{1}{16}, \quad OE = \frac{13}{8}, \quad EH = FG = OF \sin ADB = 2 \sin 3\alpha = 2a.$$

The parabola has its vertex at O and focus at S . The circle has its centre at H and passes through O . PQ is drawn parallel to OB through the intersection P , and OQ is made equal to OC ; this is unit length. Then if the ordinate of P is y ,

$$\sin QOC = \frac{y}{OQ} = y = \sin \alpha = \sin \frac{AOB}{3}.$$

Hence the angle QOC is one-third of the angle AOB .

(4) *Other Methods derived from those already given.*

In any of the preceding cases (IV. 1, 2 or 3) the equations of the circle and conic may be combined to form an equation of the second degree, which will be the equation of another conic intersecting the circle in the four points common to the circle and the original conic. For example: in the method of Clairaut (IV. 2, *Fig. 10*), if H be taken as the origin and BH as the axis of x , the equations of the circle and hyperbola will be:

$$x^2 + 2ax + y^2 + 2by = 0,$$

and

$$3x^2 + 4ax - y^2 = 0,$$

where

$$a = EH \text{ and } b = SE.$$

Hence, if λ be any constant, the conic

$$\lambda(x^2 + 2ax + y^2 + 2by) + 3x^2 + 4ax - y^2 = 0$$

will cut the circle at the four points H, P, P_1, P_2 , and may therefore be used to trisect the angle BSH . Any number of solutions are possible, since any value may be assigned to λ . Some of the simpler cases are as follows:

is the intersection of a radius vector OR and an ordinate NP , each of which lines moves at a uniform rate such that N describes the diameter BC in the same time as R describes the semi-circumference BC . In other words, BN is the same fraction of the radius OB as the arc BR is of the quadrant BD .

If RS be drawn parallel to OB to meet the ordinate NP at S , the locus of S is a sine (or cosine) curve. This curve was used for trisection purposes by Dinostratus, a disciple of Plato (see Pappus), and by Tschirnhausen (1651-1708), to whom Saxony owed its porcelain manufactory.

The Spiral of Archimedes is also shown in *Fig. 12*. It is the locus of the point X on the radius vector OR such that OX increases uniformly as the angle BOR increases uniformly. In the particular curve shown, OX is equal to BN .

The use of these three curves to obtain an angle BOQ equal to one-third of the angle AOB will be obvious from the figure. BM is made equal to one-third of BN , and OZ or OY equal to one-third of OX .

It is interesting to notice the connection of the Quadratrix curve with the quadrature of the circle.

Let the angle DOR be equal to θ radians, and let $OP=r$. Also let $OD=a$ and $OE=b$.

Then

$$r \sin \theta = ON = OB \times \frac{\text{arc } DR}{\text{quadrant } DB} = a \frac{\theta}{\pi/2}.$$

Therefore

$$r = \frac{a}{\pi/2} \cdot \frac{\theta}{\sin \theta}.$$

At the point D

$$\frac{\theta}{\sin \theta} = 1 \text{ and } r = b.$$

Therefore

$$b = \frac{a}{\pi/2}.$$

Therefore at any point P

$$r \sin \theta = b \theta = a \theta \times b/a.$$

Therefore

$$ON = \text{arc } DR \times OE/OD,$$

or

$$OE : OD = ON : \text{arc } DR.$$

Also area of sector DOR

$$= \frac{1}{2} OD \times \text{arc } DR$$

$$= \frac{1}{2} OD \times ON \times \frac{OD}{OE}$$

$$= \text{area of triangle } ODP \times OD/OE.$$

TRIAL METHODS.

Several of the methods of trisecting an angle involve a problem which may be solved, not only by using a locus, as in the examples already given, but also by making a series of trials until the diagram is correctly drawn. In the following examples the trials are such as can easily be made.

I. The construction of Archimedes (*Fig. 1*) can readily be accomplished by trial. Straight lines may be drawn through A until it is found by measurement that the intercept ED is equal in length to the radius of the circle. The actual drawing of the lines may be avoided by marking on the edge of a ruler the length of the radius and applying the ruler to the diagram so that the edge passes through the point A and the two marks lie, one on the circle at E , the other on CB produced at D .

Another appliance which can be used to determine the points E and D was invented by Hermes⁹ and is shown in *Fig. 13*. The instrument is a pair of dividers one leg of which is provided with two points P and Q separated by a fixed distance. The legs are hinged so that the three points are always co-linear when touching

⁹ W. Dyck. "Katalog Mathematischer und Mathematisch-physikalischer Modelle, Apparate und Instrumente." Munich, 1892.

the plane of the diagram. The method of using the instrument to determine the points E and D (*Fig. 1*) is

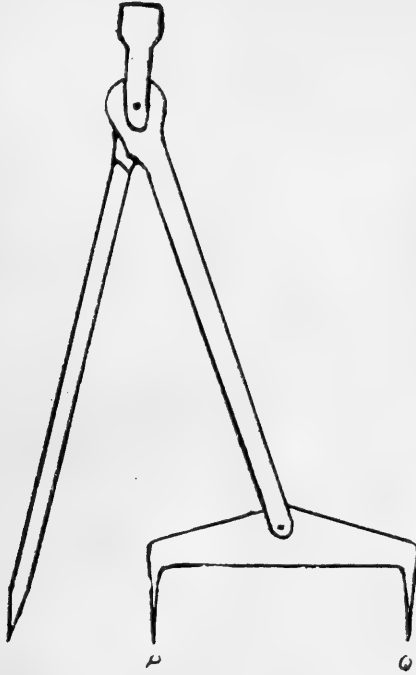

Fig. 13. Trisection Dividers.

obvious, provided that the radius of the circle be made equal to the distance PQ .

II. The angle ABC in *Fig. 14* may be trisected by

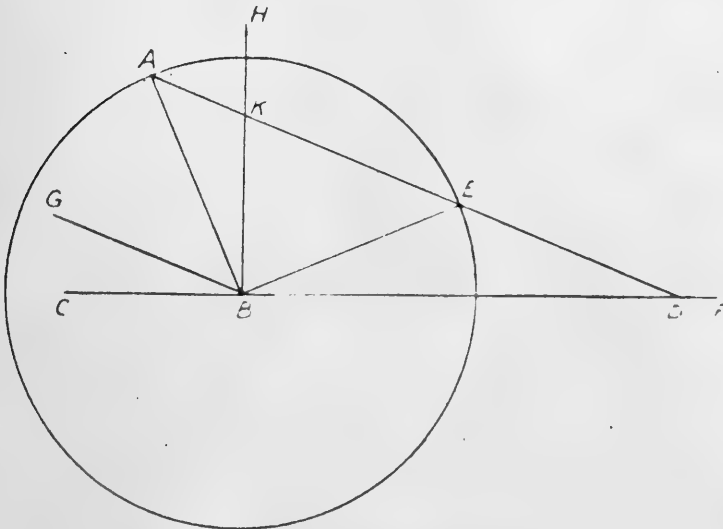

Fig. 14. Method of Jordanus.

drawing BH perpendicular to BC and placing a straight line AKE through A so that the intercept KE is equal to the radius of the circle. BG , drawn parallel to AKE is then a trisector. (Compare with *Figs. 1* and *5*.) This method is given by a monk, Jordanus Nemorarius.¹⁰ He accomplished the trisection by giving a ruler simultaneously a rotating and sliding motion, its final position being fixed with the aid of a certain length marked on the ruler.¹¹

III. Alsidschzi¹² used the following method: Let ABC be the angle (*Fig. 15*) to be trisected. With B as centre

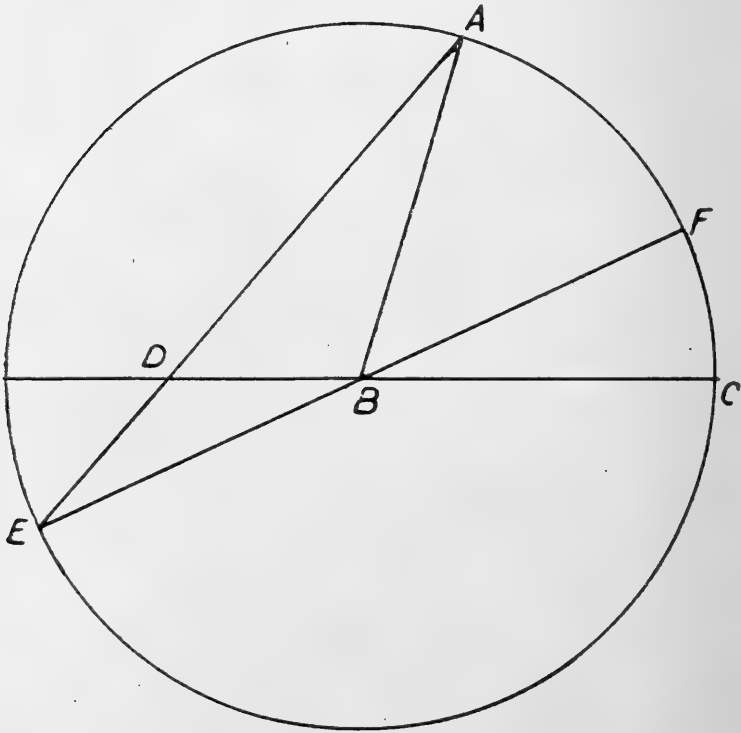

Fig. 15. Method of Alsidschzi.

and any radius BA describe a circle. Through A place a

¹⁰ "De Triangulis" (*circa* 1170), printed by Curtze in 1887.

¹¹ See Cantor, "Vorlesungen über Geschichte der Mathematik, Vol. II., p. 75, 1892.

¹² An Arabian mathematician.

straight line ADE so that the intercept DE shall be equal to DB . Join EB and produce EB to F . Then obviously the angle CBF is one-third of the angle ABC .

IV. The following two methods are given by G. A. Kenner von Löwenturn in the course of a correspondence with Huygens (1653-4)¹³:

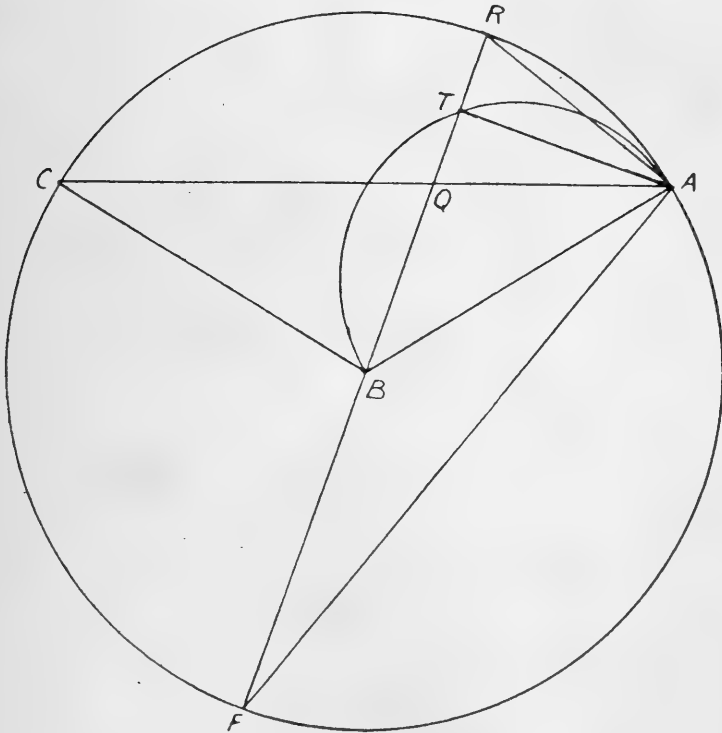

Fig. 16. Löwenturn's Method (No. 1).

1. Let ABC (*Fig. 16*) be the angle to be trisected. With B as centre describe a circle cutting off BA, BC . Draw the chord AC . Through B place a straight line BQR so that AQ shall be equal to the length of the chord AR . Then the angle ABR is one-third of the angle ABC . To prove this, bisect RQ at T , produce RQ to meet the circle at F , join A to F and to T . Then :

¹³ See "Œuvres de Christian Huygens." Société Hollandaise des Sciences. Vol. I. (1888.)

$$\angle CAR = 2 \angle RAT = 2 \angle AFR.$$

Therefore

$$\text{arc } CR = 2 \text{ arc } AR.$$

Therefore

$$\text{angle } ABC = 3 \text{ angle } ABR.$$

The placing of the line BR may be facilitated by describing a semicircle on BA as diameter and making trials until QR is bisected by the semicircle.

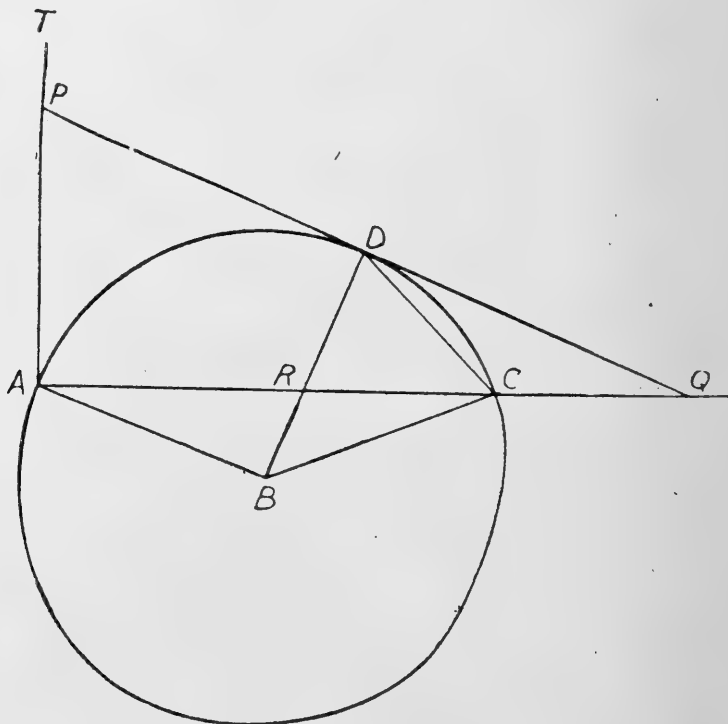

Fig. 17. Löwenthorn's Method (No. 2).

2. Let ABC (Fig. 17) be the angle to be trisected. As before, describe a circle with centre B and draw the chord AC . Draw AT perpendicular to AC . Place a tangent to the circle so that the length PQ intercepted between AT and AC is bisected at the point of contact D . Join B to D . Then the angle DBC is one-third of the angle ABC . The proof is similar to that preceding, for it is easily seen that the chord DC is equal to RC .

V. Another method of trisecting an angle involving the drawing of a tangent was suggested to one of the authors by the fact that a *limaçon* is a pedal curve to a fixed circle with reference to a fixed point. Let ABC (Fig. 18) be the angle to be trisected. With any point A

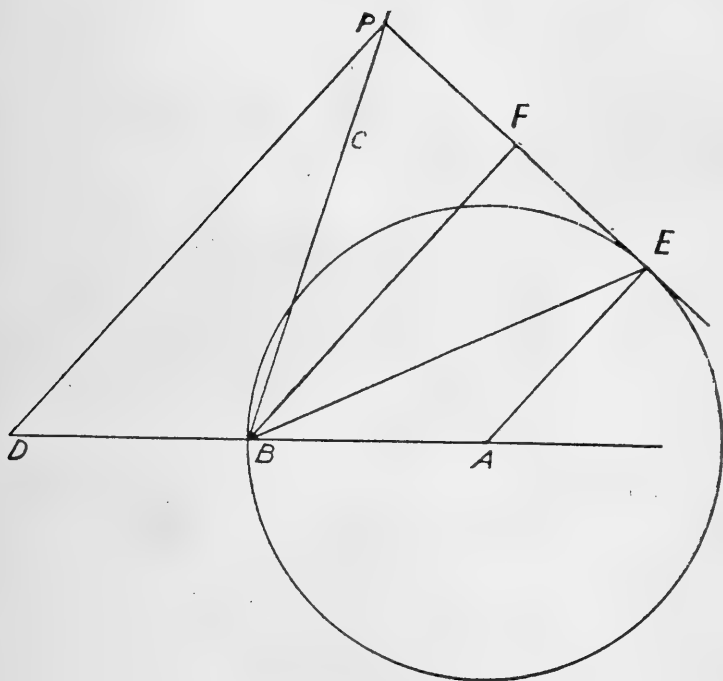

Fig. 18. (New Method.)

as centre and AB as radius describe a circle. Produce AB , making BD equal to AB . Find a point P on AC such that PD is perpendicular to a tangent drawn to the circle through P . Then if E be the point of contact and if PE be bisected at F , BE and BF are obviously the trisectors of the angle ABC .

The point P may readily be found by using a rectangular card or a set-square, and, keeping one of the corners on the line BC , moving the card until one of the adjacent sides touches the circle while the other passes through D .

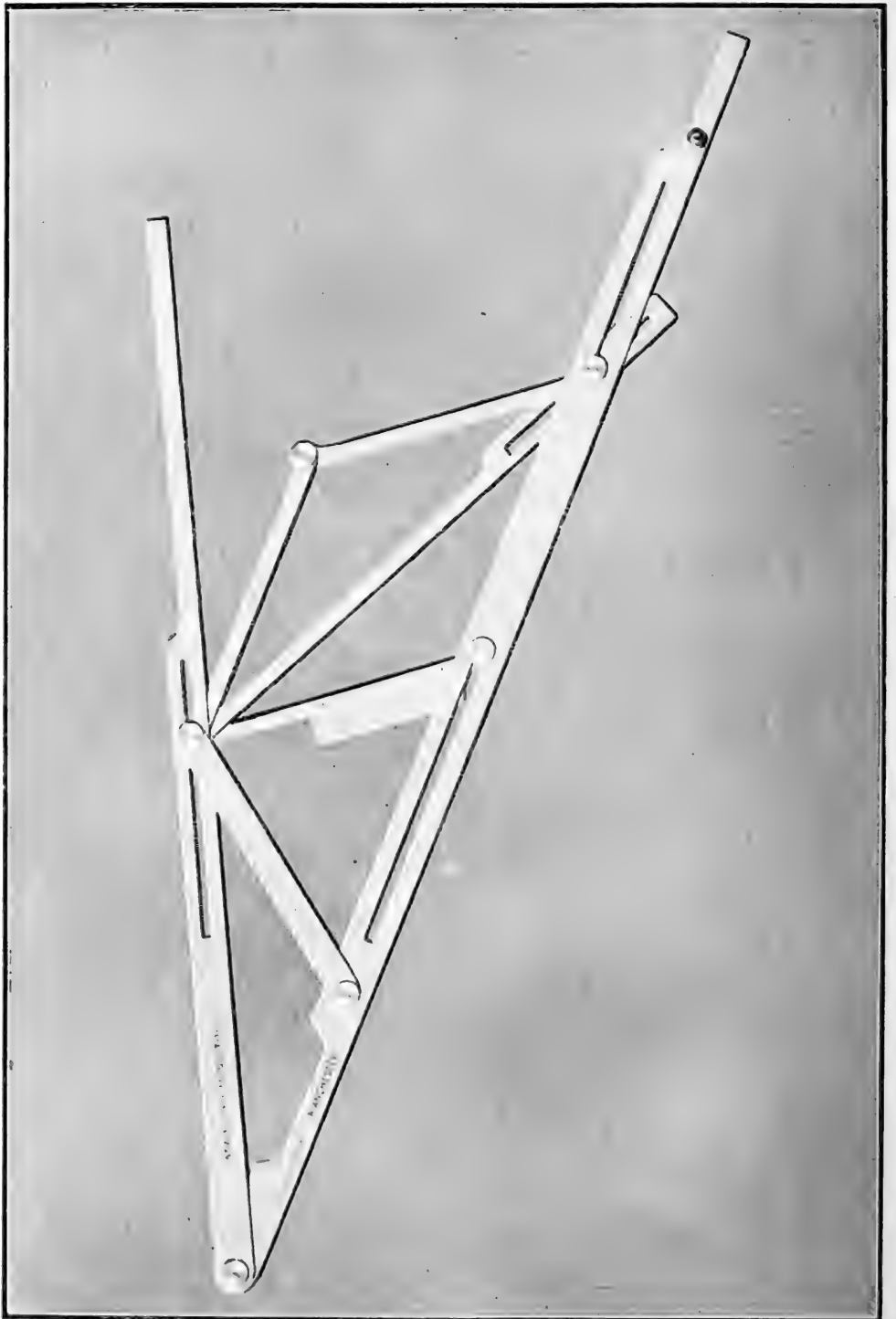

Fig. 20. Adamson's Linkwork (No. 2).

2. In the arrangement shown in *Figs. 20* and *21* (see footnote 14), two brass strips CD, DF are hinged together at D . $BAGH$ is a hinge-jointed parallelogram the sides of which are all equal. The link GA is constrained so as to move in a slot in the strip DF . The corner B is hinged to a link BE which is also hinged at a fixed point

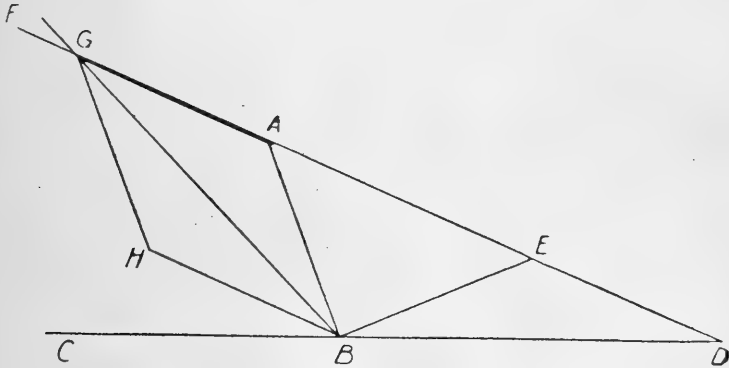

Fig. 21. Adamson's Linkwork (No. 2).

E on DF , BE and ED being each equal to the side of the parallelogram $BAGH$. The hinge B is constrained to lie in CD and may move along in a slot. Another link BG is hinged at B and is slotted so as to pass through the hinge G and form the diagonal of the parallelogram.

It will be obvious from the figure that in any position of the linkwork the angle ABC is trisected by BH and BG .

In order to facilitate the use of the linkwork as a drawing instrument, the strips BA, BG, BH and BC are shaped so that one edge corresponds to the straight lines in *Fig. 21*.

The most convenient way of using the instrument is to place the edge of the strip BA against one line bounding the angle to be trisected, and to hold it in this position by means of a metal plate (*Fig. 20*) attached to BA for that purpose. The linkwork is then adjusted

by moving a handle till the strip DC lies along the other bounding line.

It is interesting to note that as the instrument is moved in this manner the point D describes a curve which is a portion of a special form of *limaçon*.

The linkage apparatus represented in *Fig. 22* was devised by Professor J. J. Sylvester.¹⁵ The lines in the diagram represent links which are hinge-jointed at each point of intersection. The points F, G, H, K, L, M and N

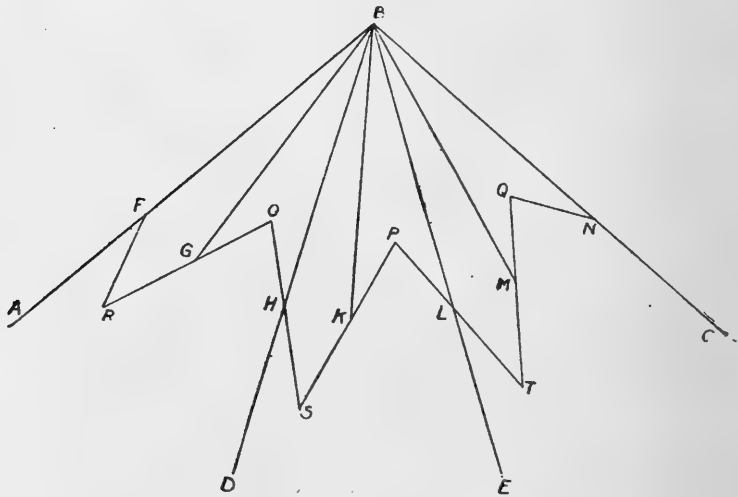

Fig. 22. Sylvester's "Angle-divider."

are all equidistant from B . The lengths OG, OH, PK, PL, QM and QN are all equal, as also are RF, RG, SH, SK, TL and TM . Consequently the angles at F, G, H, K, L, M and N are all equal or supplementary. Hence the angles FBG, HBK and LBM are equal, as also are the angles GBH, KBL and MBN . Therefore the angles ABD, DBE and EBC are equal, and the angle ABC is trisected by the links BD and BE .

Obviously by adding more links the angle between the extreme links could be divided into any required number of equal parts.

¹⁵ *Proc. London Math. Soc.*, Vol. VI., pp. 78 and 196. It is constructed by Adam Hilger, Ltd., 75a, Camden Road, London, N.W.

Approximate Methods.

Many constructions, involving the use of a pair of compasses and a ruler only, have been employed for the purpose of approximately trisecting an angle or a circular arc. Reference will now be made to some of these methods. The following table shows the results of calculations based on the various constructions. The angle to be trisected is β radians, and the theoretical result of the construction for $\beta/3$ is α radians. The error $\alpha - \beta/3$ is given in radians, neglecting powers of $\beta/3$ which are at least two higher than the power stated. The actual values in degrees, minutes and seconds corresponding to α are given in the cases where β corresponds to 90° and 45° respectively. It is to be noticed that if an angle be bisected and then the approximate trisection construction be applied to one of the halves, one of the trisecting lines will also be a trisecting line of the whole angle. Thus any angle up to 90° may be trisected with an actual error not

Method.	Error = $\alpha - \frac{\beta}{3}$.	Approximation to 1/3 of 90° ($=30^\circ$).	Approximation to 1/3 of 45° ($=15^\circ$).
<i>A</i>	$+\frac{2}{3}\left(\frac{\beta}{3}\right)^3$	$36^\circ 52'$	$15^\circ 43' 20''$
<i>B</i>	$-\frac{1}{9}\left(\frac{\beta}{3}\right)^5$	$29^\circ 40' 30''$	$14^\circ 59' 30''$
<i>C</i>	$+\frac{1}{6}\left(\frac{\beta}{3}\right)^3$	$30^\circ 55' 20''$	$15^\circ 9' 12''$
<i>D</i>	$-\frac{1}{3}\left(\frac{\beta}{3}\right)^3$	$26^\circ 34'$	$14^\circ 38' 20''$
<i>E</i>	$-\frac{1}{144}\left(\frac{\beta}{3}\right)^7$	$29^\circ 54' 44''\cdot6$	$14^\circ 59' 59''\cdot88$
<i>F</i>	$+\frac{1}{648}\left(\frac{\beta}{3}\right)^9$	$30^\circ 0' 0''\cdot93$	$15^\circ 0' 0''\cdot0018$

exceeding that given as the error when the angle to be trisected is 45° .

*Method A.*¹⁶—The construction depends upon the fact that the equation :

$$\sin(\beta - \alpha) = \frac{1}{2} \sin \beta + \frac{1}{2} \sin \alpha$$

is true if

$$\alpha = \frac{\beta}{3} + \frac{2}{3} \left(\frac{\beta}{3} \right)^3 \text{ when we neglect } \left(\frac{\beta}{3} \right)^5.$$

*Method B.*¹⁷ was suggested by Method A. In this case the construction solves the equation :

$$\sin(\beta - \alpha) = \frac{1}{4} \sin \beta + \frac{5}{4} \sin \alpha,$$

which is true when

$$\alpha = \frac{\beta}{3} - \frac{1}{9} \left(\frac{\beta}{3} \right)^5, \text{ if } \left(\frac{\beta}{3} \right)^7 \text{ is neglected.}$$

*Method C.*¹⁸—The construction solves the equation :

$$6 \sin \alpha + 3 \sin(\beta - \alpha) = 8 \sin \beta/2,$$

which is true when

$$\alpha = \frac{\beta}{3} + \frac{1}{6} \left(\frac{\beta}{3} \right)^3 \text{ if } \left(\frac{\beta}{3} \right)^5 \text{ be neglected.}$$

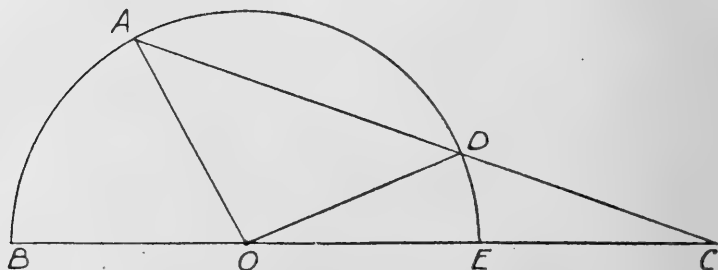

Fig. 23. Snell's Approximate Method.

Method D was used by Snell (1546-1613) and is extremely simple. Let AOB (Fig. 23) be the angle to be

¹⁶ C. S. Bingley in *Knowledge*, Nov., 1911.

¹⁷ R. F. Davies, *Mathematical Notes*, Edinburgh Math. Soc., May, 1912.

¹⁸ Nevil Maskelyn, *Philosophical Magazine*, April, 1912.

trisected. With O as centre and any radius OA describe a circle cutting BO produced at E . Make $EC = OE$. Join AC . Then angle ACO is nearly one-third of angle AOB . If angle $AOB = \beta$ and angle $ACO = \alpha$, then

$$\sin(\beta - \alpha) = 2 \sin \alpha,$$

from which it follows that

$$\alpha = \frac{\beta}{3} - \frac{1}{3} \left(\frac{\beta}{3} \right)^3, \text{ neglecting } \left(\frac{\beta}{3} \right)^5.$$

Let AC intersect the circle at D . Join OD . Then if the angle $DOC = \alpha'$, $\beta + \alpha' = 2(\beta - \alpha)$, therefore

$$\alpha' = \beta - 2\alpha = \frac{\beta}{3} + \frac{2}{3} \left(\frac{\beta}{3} \right)^3$$

and

$$\sin \frac{\beta + \alpha'}{2} = 2 \sin \frac{\beta - \alpha'}{2}$$

or

$$\sin(\beta - \alpha') = \frac{\sin \beta}{2} + \frac{\sin \alpha'}{2}.$$

Thus α' is the same approximation to $\beta/3$ as that obtained by Method A.

Method E.—An obvious method of trisecting an angle or a circular arc is to first find, by estimation or construction, an approximation to one-third, and then to add to or subtract from this, as nearly as possible one-third of the difference between the whole angle or arc and three times the first approximation.

The following methodical way of performing these operations is given by Cantor and attributed to Albrecht Dürer¹⁹ (1471-1528).

Let ABC (*Fig. 24*) be the angle to be trisected. With B as centre and any radius describe a circle HVK cutting AB at H and CB at K . Join HK . Trisect the chord HK at M and N . With H as centre and HM as radius

¹⁹ M. Cantor, "Vorlesungen über Geschichte der Mathematik," Vol. II., p. 425, 1892.

describe a circle cutting the circle HVK at P' . Draw MP'' perpendicular to HK . With H as centre describe a circle passing through P'' cutting HK at R . Trisect MR at X and Y . With H as centre and HY as radius

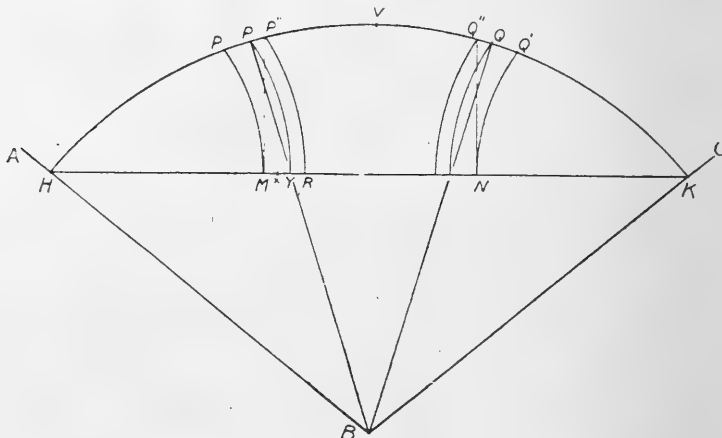

Fig. 24. Dürer's Approximate Method.

describe a circle cutting the circle HVK at P . Similarly obtain the points Q' , Q'' and Q . Draw BP , BQ . BP and BQ are then the approximate trisectors of ABC . The arcs HP' , $P''Q''$ and $Q'K$ are obviously exactly equal, and to each of these is added an approximation to one-third of the sum of the arcs $P'P''$, $Q'Q''$.

Method F.—Although the construction of method E gives a very close approximation to trisection, a much closer approximation is obtained by the following variation devised by one of the writers.

Let ABC (*Fig. 25*) be the angle to be trisected. With B as centre and any radius describe a circle ERG cutting BA at E and BC at G . With B as centre and radius equal to three times BE describe a circle HVK cutting BA at H and BC at K . Join EG , HK . Now with H as centre and radius equal to EG describe an arc cutting HK at M and the circle HVK at P' . Join E to M and

produce EM to meet the circle HVK at P'' . Draw BP' and BP'' cutting the circle ERG at R and S respectively. Draw the chord RS . With P'' as centre and radius equal

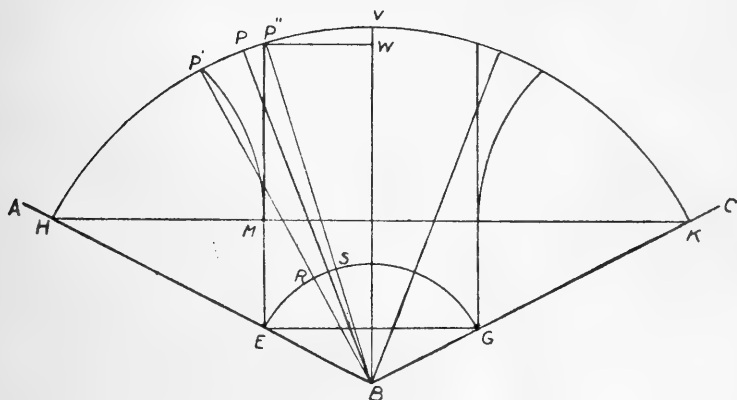

Fig. 25. Modification of Dürer's Method.

to RS describe an arc cutting the arc $P''P'$ at a point P . Connect B to P , then BP is one of the approximate trisectors.

It will now be proved that the angle ABP only exceeds one-third of the angle ABC by $\frac{1}{648} \left(\frac{\beta}{3}\right)^9$ radians, where the angle ABC is β radians and the terms neglected involve $\left(\frac{\beta}{3}\right)$ to at least the 13th power. Draw BV perpendicular to HK and $P''W$ parallel to HK . Let the circular measure of angles ABC , ABP , PBP'' , $P'BP''$ and ABP' be β , α , γ , δ and θ respectively. Then, since angle $P''BW = \theta/2$,

$$3 \sin \theta/2 = \sin \beta/2 ;$$

hence by expanding,

$$\theta = \frac{\beta}{3} - \frac{1}{3} \left(\frac{\beta}{3}\right)^3, \text{ neglecting } \left(\frac{\beta}{3}\right)^7.$$

But

$$\delta = \frac{1}{2} (\beta - 3\theta).$$

Therefore

$$\delta = \frac{1}{2} \left(\frac{\beta}{3} \right)^3, \text{ neglecting } \left(\frac{\beta}{3} \right)^7.$$

Also

$$3 \sin \frac{\gamma}{2} = \sin \frac{\delta}{2},$$

hence

$$\gamma = \frac{\delta}{3} - \frac{1}{3} \left(\frac{\delta}{3} \right)^3, \text{ neglecting } \left(\frac{\delta}{3} \right)^7.$$

But

$$\begin{aligned} \alpha = \theta + \delta - \gamma &= \frac{\beta - 2\delta}{3} + \delta - \frac{\delta}{3} + \frac{1}{3} \left(\frac{\delta}{3} \right)^3 \\ &= \frac{\beta}{3} + \frac{1}{3} \left(\frac{\delta}{3} \right)^3 \text{ neglecting } \left(\frac{\delta}{3} \right)^7 \\ &= \frac{\beta}{3} + \frac{1}{648} \left(\frac{\beta}{3} \right)^9 \text{ neglecting } \left(\frac{\beta}{3} \right)^{13}. \end{aligned}$$

In addition to the preceding methods an angle, say AOB , may be trisected approximately by repeated bisections, thus:—

- Bisect AOB by OP_1 ,
- „ AOP_1 by OP_2 ,
- „ BOP_2 by OP_3 ,
- „ AOP_3 by OP_4 , and so on.

The bisecting lines ultimately become the trisecting lines of angle AOB .

Proof.—Let angle $AOB = \beta$, then

$$P_1OB = AOP_1 = \beta/2$$

$$AOP_2 = \beta/4$$

$$BOP_3 = \frac{1}{2}(BOP_2) = \frac{1}{2}(BOA) - \frac{1}{2}(AOP_2) = BOP_1 - \beta/8$$

$$\therefore P_1OP_3 = \beta/8$$

$$AOP_4 = \frac{1}{2}(AOP_3) = \frac{1}{2}(AOP_1) + \frac{1}{2}(P_1OP_3) = AOP_1 + \beta/16$$

$$\therefore P_2OP_4 = \beta/16.$$

Similarly:—

$$BOP_5 = \frac{1}{2}(BOP_4) = \frac{1}{2}(BOP_2) - \frac{1}{2}(P_2OP_4) = BOP_3 - \beta/32$$

$$\therefore P_3OP_5 = \beta/32$$

$$AOP_6 = \frac{1}{2}(AOP_5) = \frac{1}{2}(AOP_3) + \frac{1}{2}(P_3OP_5) = AOP_4 + \beta/64$$

$$\therefore P_4OP_6 = \beta/64.$$

Thus after $2n$ bisections:—

$$\begin{aligned} AOP_{2n} &= AOP_2 + P_2OP_4 + P_4OP_6 + \dots + P_{2n-2}OP_{2n} \\ &= \frac{\beta}{4} + \frac{\beta}{16} + \frac{\beta}{64} + \dots + \frac{\beta}{2^{2n}} \\ &= \frac{\frac{\beta}{4} \left(1 - \frac{1}{4^{2n}} \right)}{1 - 1/4} = \frac{\beta}{3} \left(1 - \frac{1}{2^{2n}} \right). \end{aligned}$$

In conclusion, the problem of trisecting an angle is essentially, as Pappus noted, *a solid problem* or one of the third degree, requiring the solution of a cubic equation. Thus an *exact* trisection must be impossible in practice with the aid only of a ruler and a pair of compasses. Owing to this not having been realised, much time and labour has been wasted in striving to obtain an exact solution of the problem.²⁰

²⁰ De Morgan in his "Budget of Paradoxes," pp. 255-258 (1872), cites some examples.

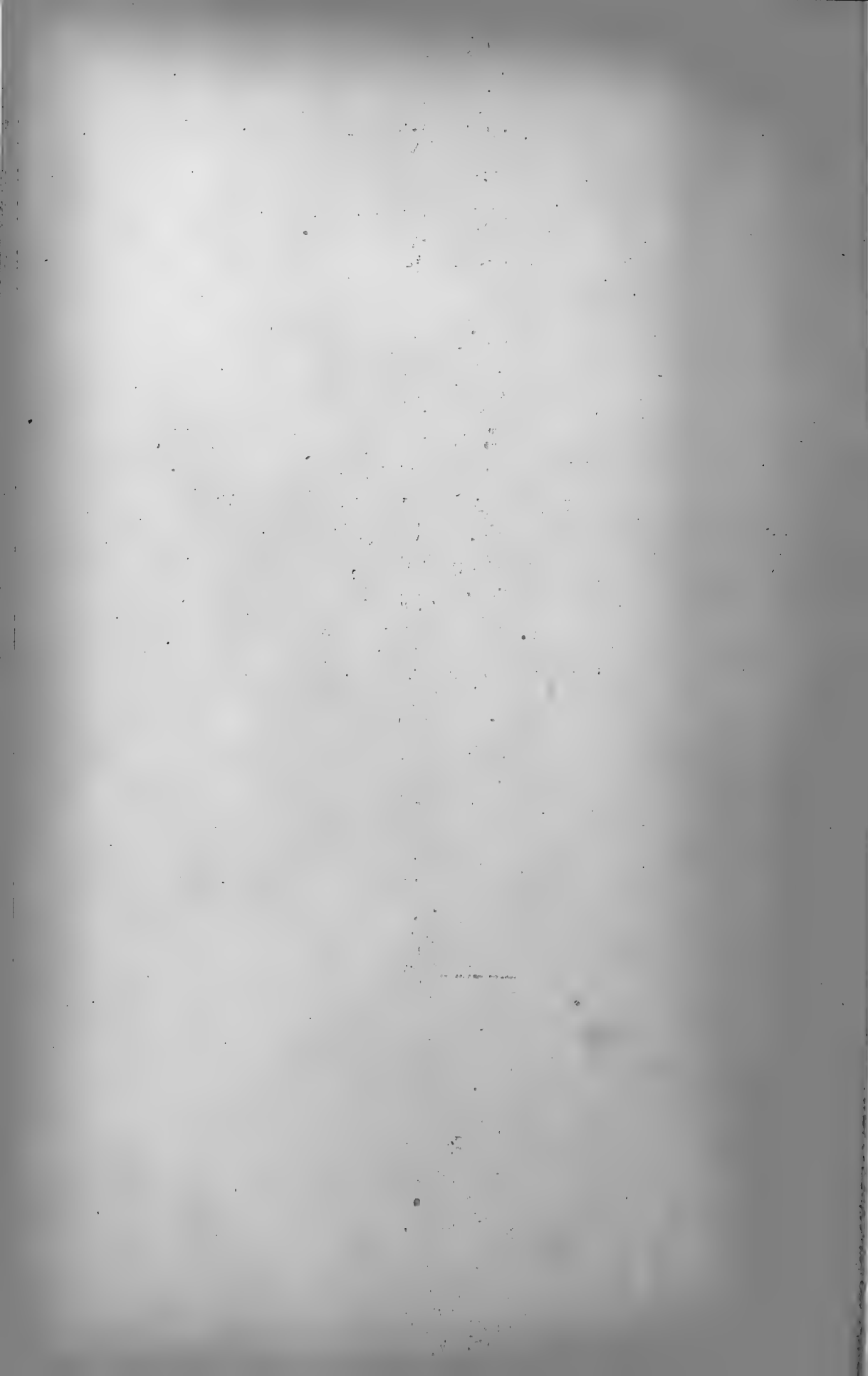

PROCEEDINGS
OF
THE MANCHESTER LITERARY AND
PHILOSOPHICAL SOCIETY.

Ordinary Meeting, October 6th, 1914.

The President, Mr. FRANCIS NICHOLSON, F.Z.S.,
in the Chair.

Mr. C. L. BARNES, M.A., drew attention to the recent accessions to the Society's Library, and a vote of thanks was passed to the donors of the books upon the table. The following works were included in the recent accessions to the Society's Library: "*Report on the Lagenae of the South-West Pacific Ocean (Supplementary Paper)*," by Henry Sidebottom (8vo., London, 1913), presented by the Author; "*Corrections to the places of the Cambridge (Ast. Gesell.) Catalogue deduced from Photographic Measures on the Plates of the Oxford Section of the Astrographic Catalogue. Oxford Astrographic Catalogue*," Vol. VIII., Part I. (4to., Edinburgh [1913]), "*Tables for facilitating the use of Harmonic Analysis*," arranged by H. H. Turner (8vo., London, 1913), and "*Collated List of Lunar Formations named or lettered in the Maps of Neison, Schmidt, and Mädler*," compiled and annotated for the Committee by Mary A. Blagg under the direction of the late S. A. Saunder (Lunar Nomenclature Committee...), (8vo., Edinburgh, 1913), presented by the University Observatory, Oxford; "*An Account of a Land Map of the World*," by B. J. S. Cahill (8vo., n.p., 1913), presented by the Cahill World Map Co.; "*Results of Magnetic Observations...*

U.S. Coast and Geodetic Survey," by R. L. Faris (Special Bulletin, No. 15), (4to., Washington, 1913), "*Fourth General Adjustment...level Net...United States*," by W. Bowie and H. G. Avers (Special Bulletin, No. 18), (4to., Washington, 1914), "*Results of Observations...U.S. Coast and Geodetic Survey at the Observatory at Sitka, Alaska*," by D. L. Hazard (4to., Washington, 1914), presented by the United States Coast and Geodetic Survey, Washington; "*Lag in Marine Barometers on Land and Sea*," by Charles Chree (Geophysical Memoirs, No. 8) (4to., Edinburgh, 1914), presented by the Meteorological Office, London; "*De Voeding der Oester*," by J. A. Heymann (8vo., Gravenhage, 1914), "*Biochemische Suikerbepalingen*," by A. J. Kluyver (8vo., Leiden, 1914), "*Over het Verwerken van Tinertsen*," by Jan Rueb (8vo., Den Haag, 1913), "*Drinkwaterreiniging met Hypochloricten*," by J. D. Ruys (8vo., Rotterdam, 1914), "*Grundlagen der Vektor-und Affinoranalysis*," by J. A. Schouten (8vo., Leipzig, &c., 1914), "*De Oxydatie en de Polymerisatie van Sojaolie*," by N. J. A. Taverne (8vo., Leiden, 1913), and "*Temperatuurmetingen in een Dieselmotor*," by E. B. Wolff (8vo., Amsterdam, n.d.), presented by the Technische Hoogeschool, Delft; "*Report on Radiation and the Quantum Theory*," by J. H. Jeans (8vo., London, 1914), presented by the Physical Society, London; "*An Historical Account of the Origin...of the American Philosophical Society*," by P. S. du Ponceau (8vo., Philadelphia, 1914), presented by the American Philosophical Society, Philadelphia; "*Subject List of Works on Photo-Mechanical Printing and Photography...Library of the Patent Office*," (New Series, CA—CC) (16mo., London, 1914), "*Subject List of Works on the Fine and Graphic Arts...Library of the Patent Office*," (New Series, BM—BZ) (16mo., London, 1914), "*Subject List of Works on the Silicate Industries...Library of the Patent Office*," (New Series, CD—CK) (16mo., London, 1914), "*Subject List of Works on General Physics...Library of the Patent Office*," (New Series, FS—GF) (16mo., London, 1914), "*Subject List of Works on Enamelling, Art Metal-Work, &c....Library of the Patent Office*," (New Series, CK15—CO17)

(16mo., London, 1914), and "*Subject List of Works on Sound and Light...Library of the Patent Office*," (New Series, GG—GP) (16mo., London, 1914), presented by the Library of the Patent Office, London; and "*Reuben Gold Thwaites*," by F. J. Turner (12mo., Madison, Wis., 1914), presented by the State Historical Society of Wisconsin, Madison, U.S.A.

The PRESIDENT referred with regret to the losses the Society had sustained by the death of Mr. THOMAS KAY, J.P., Mr. THOMAS THORP, F.R.A.S., and Mr. R. B. LONGRIDGE, M.I.Mech.E. Mr. Kay, who had been a member of the Society for twenty-eight years, died on September 22nd last. Mr. Thorp, who at the time of his death was a member of the Council, died on June 13th. He was a Vice-President of the Society from 1908-1911, and a Member of the Council from 1904-1908 and 1911-1912. He made many communications at the Society's meetings. Mr. Longridge, who at the time of his death was the oldest member of the Society, having been elected in 1857, died on August 4th. Mr. F. J. FARADAY, F.L.S., a member of the Society from 1883-1908, Secretary from 1886-1895, and the author of many communications at our Meetings, died on August 3rd last.

An **Exhibition of some Original Diagrams used by Dalton** was arranged.

Mr. R. L. TAYLOR, F.C.S., F.I.C., drew attention to a valuable and interesting collection of original pen-and-ink diagrams, used by Dr. John Dalton, which had been found in the Society's possession. The collection consisted of about one hundred and thirty drawings, the majority of which were in a good state of preservation, and were apparently used by Dalton in the illustration of his lectures and for general teaching purposes. A number of them are reproduced in Dalton's "*A New System of Chemical Philosophy*," and elsewhere. The uncertainty in Dalton's mind as to the number of atoms present in water, ammonia, carbon-dioxide, and other compounds is faithfully reflected in some of the diagrams, and his attempts to

depict the constitution of these and more complex bodies are full of interest.

Professor HALDANE GEE also described some of the exhibits. He pointed out that the diagrams could be divided, roughly, into three sections, under the headings: (a) physical, (b) illustrating Dalton's Atomic Theory, and (c) meteorological and general subjects.

A Report on these diagrams will be published in the *Memoirs*.

General Meeting, October 20th, 1914.

The President, Mr. FRANCIS NICHOLSON, F.Z.S.,
in the Chair.

Mr. ALLAN B. FIELD, M.A. (Camb.), B.Sc. (Lond.), M.I.E.E.,
Professor of Mechanical Engineering, The Municipal School of
Technology, Manchester, and *Kingslea, Strines Road, Marple,
Cheshire*, was elected an ordinary member of the Society.

Ordinary Meeting, October 20th, 1914.

The President, Mr. FRANCIS NICHOLSON, F.Z.S.,
in the Chair.

A vote of thanks was accorded the donors of the books upon the table. These included: "*Catalogue of Mesozoic Plants in...British Museum (Natural History). The Cretaceous Flora*," Part I., by Marie C. Stopes (8vo., London, 1913), and "*A Revision of the Ichneumonidae*," Part III., by Claude Morley (8vo., London, 1914), presented by the Trustees of the British Museum.

An engraving of Elihu Burritt, presented to the Society by Mrs. E. Tootal Broadhurst, was exhibited.

Mr. R. L. TAYLOR, F.C.S., F.I.C., exhibited a Japanese "Magic" mirror made by the late Mr. Thomas Thorp (*vide Manchester Memoirs*, vol. xlvii., No. 7). A second Japanese "Magic" mirror was exhibited by Mr. C. L. BARNES, M.A.

Professor SYDNEY J. HICKSON, M.A., D.Sc., F.R.S., exhibited a collection of "Sea-Pens" from the Malay Archipelago.

Dr. J. STUART THOMSON, F.L.S., F.R.S.E., gave a summary of a paper entitled "**Sea-Pens' from the Cape of Good Hope.**"

This paper is printed in full in the *Memoirs*.

General Meeting, November 3rd, 1914.

The President, Mr. FRANCIS NICHOLSON, F.Z.S.,
in the Chair.

Dr. CHARLES ALFRED EDWARDS, Professor of Metallurgy and Metallography in the Victoria University of Manchester, and of 26, *Lyndhurst Road, Withington, Manchester*, and Mr. HARRY RICHARDSON, M.Sc., Demonstrator in Physics, The Municipal School of Technology, and of 98, *Dudley Road, Whalley Range, Manchester*, were elected ordinary members of the Society.

Ordinary Meeting, November 3rd, 1914.

The President, Mr. FRANCIS NICHOLSON, F.Z.S.,
in the Chair.

A vote of thanks was accorded the donors of the books upon the table.

Mr. C. L. BARNES, M.A., drew attention to volumes 2-10 of "*The Entomologist*," recently purchased by the Society, thus completing the set from volume 2.

Mr. W. C. JENKINS, F.R.A.S., Curator of the Godlee Observatory, exhibited the Aerolite which fell at Upholland, near Wigan, on October 13th.

Mr. Jenkins stated that the aerolite aroused great interest at the time of its fall owing to the reports claiming it to be of terrestrial origin. It can be assumed that this body had been moving freely in space until, on approaching the earth, the gravitational attraction of the larger mass gathered it in, the result being a very rapid movement through the earth's atmosphere with the consequent heating of the surface of the mass in such a way as to round off all corners. An examination of the fracture shows that this heating has not penetrated to any great depth, only to an average of about 1 mm. in thickness.

Soon after its approach a violent explosion was heard throughout Lancashire, Cheshire, and the surrounding counties. The result of the explosion is evident on examination of the parts which were fractured before its entry into the earth. "Falls" have been recorded at Davenham, near Northwich, and at Stretford, though at present the fragments have not been found.

From observations of the visible track of the meteor, Mr. Denning, of Bristol, estimated the height of the object when it was over Stoke-upon-Trent to be about 29 miles and that it would reach the earth some 49 miles away at a point 20 miles west of Manchester. This proved to be about the position in which the mass was found. It is the largest "find" in England for 120 years. A stone of $3\frac{1}{2}$ lbs. fell at Middlesbrough in 1881, and a fall of iron, weighing $7\frac{3}{4}$ lbs., occurred in Shropshire in 1876. The weight of the two pieces exhibited was 28 lbs. 13 ozs., and there is evidence that some 2 lbs. or so is missing.

The mass does not show any marked magnetic effect, though individual grains selected are strongly magnetic. The constituents are mainly basic silicates, with iron and nickel.

The point from which it came, $348^{\circ} + 2^{\circ} \text{N}$, was given as the radiant, and is the position that comet Daniels would have passed in the year 1907, though we should have been in proximity on September 12th rather than on October 13th; but during this period there have been several very bright meteors from this particular radiant.

In reference to this Aerolite the following note from Dr. HENRY WILDE, F.R.S., was also read:—

Alderley Edge,

November 2nd, 1914.

I notice that the meteorite, which fell at Standish, near Wigan, on the 13th ult., is to be exhibited at the forthcoming meeting of the Society by the Curator of the Godlee Observatory. It may be of interest to the members to know that the meteorite passed over Alderley about 8-45 p.m. in a north-westerly direction, leaving a luminous trail behind it. The passage was followed two minutes afterwards by a deep booming explosion, which shook the windows of houses on the Edge and caused some alarm to members of my household.

From the interval of time between the disappearance of the meteorite and the explosion, the distance from Alderley was calculated from the velocity of sound (1,130 feet per second) to be 26 miles; a near approximation to the place where the meteorite was subsequently found.

$$\begin{aligned} 1,130 \text{ feet} \times 120 \text{ seconds} &= \frac{135,600}{5,280 \text{ feet}} = 26 \text{ miles.} \\ 1 \text{ mile} &= 5,280 \text{ feet} \end{aligned}$$

In my paper, read before the Society in 1910, vol. lv., "*On the Origin of Cometary Bodies*," attention was directed to Schiaparelli's discovery that the orbits of certain comets are identical with those of the well-known streams of November meteors. I also stated that the place of origin of these erratic bodies is within the confines of the Solar system. All meteorites, as is well known, are mechanical mixtures of elementary substances and their compounds, and further indicate them as the ejectamenta of planetary bodies.

H. WILDE.

Mr. HENRY DAY, B.Sc., read a paper entitled "**Variation in a Carboniferous Brachiopod.**"

This paper is printed in full in the *Memoirs*.

General Meeting, November 17th, 1914.

Mr. R. L. TAYLOR, F.C.S., F.I.C., Honorary Secretary,
in the Chair.

Mr. NIELS BOHR, Ph.D. (Copenhagen), Reader in Mathematical Physics in the Victoria University of Manchester, *The University, Manchester*, was elected an ordinary member of the Society.

Ordinary Meeting, November 17th, 1914.

Mr. R. L. TAYLOR, F.C.S., F.I.C., Honorary Secretary,
in the Chair.

A vote of thanks was accorded the donors of the books upon the table.

A communication was read from the President of the Société Académique de l'Aube recording the strenuous protest of that Society against the systematic destruction by the German armies of historic and scientific monuments in Belgium and France, and against the pretended justification of these acts which the savants of Germany have allowed themselves to make.

It was resolved that the receipt of this communication be acknowledged and that an intimation of this Society's complete concurrence with the sentiments expressed therein be conveyed to the President of the Société Académique de l'Aube.

Mr. F. W. ATACK, M.Sc.Tech., B.Sc., A.I.C., read a paper entitled, "**The Salt-formation of Oximes.**" After outlining the current theory of oxime-isomerism, due to Hantzsch and Werner, it was pointed out that there is a notable discrepancy between the formulæ first deduced by Hantzsch and Werner in support of their theory and those in agreement with the Beckmann change, and this discrepancy has never been explained. Tschugaev's statement that only the so-called alpha-dioximes form characteristic salts with metals of the eighth group of the Periodic system is incorrect, the author having obtained similar salts with the so-called gamma-dioximes. It has been found that in case an "oxime" group forms a hydrochloride, it does not form such salts. New methods for the purification of oximes were outlined, and samples of the compounds under discussion were exhibited.

General Meeting, December 1st, 1914.

The President, Mr. FRANCIS NICHOLSON, F.Z.S.,
in the Chair.

Mr. F. W. ATACK, M.Sc.Tech. (Manc.), B.Sc. (Lond.), A.I.C., Demonstrator in Chemistry, The Municipal School of Technology, Manchester, 88, *Claude Road, Chorltonville, Manchester*; and Mr. FRANK BOWMAN, B.A. (Camb.), M.Sc.Tech. (Manc.), Assistant Lecturer in Mathematics, The Municipal School of Technology, Manchester, 25, *Bishop Street, Moss Side, Manchester*, were elected Ordinary Members of the Society.

Ordinary Meeting, December 1st, 1914.

The President, Mr. FRANCIS NICHOLSON, F.Z.S.,
in the Chair.

A vote of thanks was accorded the donors of the books upon the table. Amongst these were: "*Wheat—and its Relation to the Present Crisis*," by W. A. Evans (4to., Leicester, 1914), presented by the Leicester Literary and Philosophical Society; "*On the Relation between the velocity of the Gradient Wind and that of the Observed Wind*," by J. Fairgrieve (Geophysical Memoirs, No. 9) (4to., London, 1914), "*The Effect of the Labrador Current...Temperature of the North Atlantic*," Part II., by M. W. C. Hepworth (Geophysical Memoirs, No. 10) (4to., London, 1914), "*Report on the Work carried out by the S.S. 'Scotia,' 1913*," (fol., London, 1914), and "*Maps, Charts, and Diagrams to illustrate the Report...S.S. 'Scotia,' 1913*," (fol., London, 1914), presented by the Meteorological Office, London.

Dr. HERBERT RAMSDEN made a short communication relating to the nature of wounds caused by bullets, especially wounds received at close range, which are known to present the complicated nature of "dum dum" bullet wounds.

Mr. CECIL H. LANDER, M.Sc., A.M.Inst.C.E., read a paper entitled "**Graphical Determination of the Stresses in the Main Spars of Monoplanes.**"

Professor W. H. LANG, M.B., D.Sc., F.R.S., read a paper entitled: "**Studies in the Morphology of Isoëtes. Part I., The General Morphology of the Stock of Isoëtes.**"

These papers are printed in full in the *Memoirs*.

Ordinary Meeting, December 15th, 1914.

The President, Mr. FRANCIS NICHOLSON, F.Z.S.,
in the Chair.

A vote of thanks was accorded the donors of the books upon the table. These included: "*Results of Magnetic Observations made by the United States Coast and Geodetic Survey in 1913*," by R. L. Faris (Special Publication, No. 20) (4to., Washington, 1914), and "*Results of Observations made at... Vieques, Porto Rico... 1911 and 1912*" (4to., Washington, 1914), presented by the United States Coast and Geodetic Survey; and "*Fresh Water Fishes and their Ecology*," by S. A. Forbes (8vo., n.p., 1914), presented by the Illinois State Laboratory of Natural History, Urbana, Illinois.

Mr. F. R. LANKSHEAR, B.A., M.Sc., read a paper entitled "**Quantitative Absorption Spectra. Part II., A New Ultra Violet Photometer.**"

This paper will be printed in full in the *Memoirs*.

A paper, entitled "**Some Notes on Aerolites. The Appley Bridge Aerolite of October 13th, 1914,**" was read by Mr. W. C. JENKINS, F.R.A.S., and Mr. E. L. RHEAD, M.Sc.Tech., F.I.C.

This paper will be printed in full in the *Memoirs*.

Ordinary Meeting, January 12th, 1915.

The President, Mr. FRANCIS NICHOLSON, F.Z.S.,
in the Chair.

A vote of thanks was accorded the donors of the books upon the table. These included: "*Astrographic Catalogue 1900.0 Greenwich Section Dec. + 64° to + 90°*," by F. W. Dyson

and others, Vol. III. (fol., Edinburgh, 1914), presented by the Royal Observatory, Greenwich.

Professor Weiss introduced to the Society Dr. J. Mac Leod, Professor of Botany in the University of Ghent, and for the present a guest of the University of Manchester

Professor G. ELLIOT SMITH, M.A., M.D., F.R.S., gave an account of some mummies from Torres Straits, now in museums in Sydney and Brisbane, which he examined during a recent visit to Australia. These mummies reveal a series of features in the technique of the embalmer's art curiously similar to those exhibited in ancient Egyptian mummies. This is an important confirmation of the views put forward by Professor Elliot Smith of the extension of ancient Egyptian influence to the far East and the Pacific.

Professor W. H. LANG, M.B., D.Sc., F.R.S., read a paper entitled: "**Studies in the Morphology of *Isoëtes*. Part II., The Analysis of the Stele of the Shoot of *Isoëtes lacustris* in the light of mature structure and apical development.**"

This paper will be printed in full in the *Memoirs*.

Ordinary Meeting, January 26th, 1915.

The President, Mr. FRANCIS NICHOLSON, F.Z.S.,
in the Chair.

A vote of thanks was accorded the donors of the books upon the table. Amongst these were: "*Results of Observations ... U.S. Magnetic Survey ... Tucson, 1911 and 1912*," by D. L. Hazard (4to., Washington, 1914), presented by the United States Coast and Geodetic Survey; "*Hertfordshire Maps, ... 1579-1900*," by H. G. Fordham, Parts I.-III. (4to., n.p., n.d.),

presented by the Hertfordshire Natural History Society; and "*Novem Carmina*" (8vo., Amstelodami, 1914), presented by the Kön. Akad. Wiss. zu Amsterdam.

Mr. W. C. JENKINS, F.R.A.S., read a paper entitled "**Manchester Fogs of the last ten years.**"

Prof. W. W. HALDANE GEE, B.Sc., M.Sc.Tech., read a "**Note on the Monthly Variation of Sunshine.**"

These papers are printed in full in the *Memoirs*.

A paper entitled "**Weather Repetitions, with suggestions for long distance forecast,**" was read by Mr. W. C. JENKINS, F.R.A.S.

He drew attention to the repetitions in the weather for periods of twelve hours, twenty-four hours, seven days, and the lunar month, and also annual repetitions, making certain allowances—using particularly the records of rainfall. With a view to establishing these repetitions to a definite origin, he showed the connection between numerous cyclonic paths and extra terrestrial phenomena, and assuming similar forces acting in temperate latitudes, he proceeded to demonstrate that cyclonic movements in the regions of this kingdom followed very much the variations expected under these conditions.

Ordinary Meeting, February 9th, 1915.

The President, Mr. FRANCIS NICHOLSON, F.Z.S.,
in the Chair.

A vote of thanks was accorded the donors of the books upon the table. Amongst the recent accessions were: "*The Mississippian Brachipoda of the Mississippi Valley Basin,*" by Stuart Weller (8vo., Urbana, Ill., 1914), presented by the Illinois State Geological Survey; "*Oeuvres complètes de Thomas Jan Stieltjes,*" Tome I. (4to., Groningen, 1914), presented by the

Société Mathématique d'Amsterdam ; and "*The British Marine Annelids, Vol. III., Part I.—Polychaeta,*" by W. C. McIntosh (fol., London, 1915), published by the Ray Society, purchased.

Mr. D. THODAY, M.A. and Mr. E. L. RHEAD, M.Sc.Tech., F.C.S., were nominated Auditors of the Society's accounts for the session 1914-1915.

Dr. T. GRAHAM BROWN read a "**Note on the physiology of 'walking' with especial reference to its occurrence in the unborn foetus of the cat.**"

The author stated that various reflexes have been examined in cat foetuses.

The red nuclei seem to be capable of stimulation and evoke their characteristic movements of the fore limbs.

The limb reflexes are very similar to those of the adult cat. The ipsilateral flexion-reflex and the contralateral extension-reflex have thus been observed. In the former reflex an extension rebound effect has been seen. Reflex inhibition may be observed on pitting one reflex against another.

If the foetus is shelled out of the uterus without delay into warm physiological salt solution it may be regarded as still un-born. In these circumstances unmistakable movements of progression may be obtained on producing asphyxia by pressure upon the umbilical cord. They may sometimes appear to arise spontaneously.

This observation shows that the mechanism for coördinate progression develops during intra-uterine life, and that the co-ordination of the mechanism is not conditioned after birth by a process of "learning."

The observation also shows that the rhythmic activity may be evoked by the general stimulus of asphyxiation before it has been evoked or conditioned by any rhythmic self-generated peripheral stimuli such as those which play an important part in normal progression, but have been shown not to be its intrinsic factors.

It thus also gives another demonstration of the similarity between the respiratory mechanism and that for progression.

On behalf of Professor G. ELLIOT SMITH, M.A., M.D., F.R.S., Dr. HICKLING exhibited lantern slides of "**The Darling Downs Skull.**"

At the recent meeting of the British Association in Australia Professors Edgeworth David and Wilson, of the University of Sydney, exhibited and described a completely mineralised human skull which had been found near Warwick in the Darling Downs of Queensland. In a short time they intend to publish a full report on this important discovery of the earliest human remains yet known in Australia, which seems to prove that Man reached Australia at a time when the great fossil marsupials were still living. Professors David and Wilson kindly gave Professor Elliot Smith photographs of this interesting specimen.

Ordinary Meeting, February 23rd, 1915.

The President, Mr. FRANCIS NICHOLSON, F.Z.S.,
in the Chair.

A vote of thanks was accorded the donors of the books upon the table.

The Radcliffe Library, Oxford, and the Bureau of the Annual International Tables of Constants and Numerical Data, Liverpool, have been placed on the list of Institutions to which the Society's publications are presented.

The PRESIDENT referred sympathetically to the deaths of Mr. NATHANIEL BRADLEY, F.C.S., and Mr. S. B. WORTHINGTON, M.Inst.C.E., M.I.Mech.E. Mr. Bradley, who was elected a member of the Society in 1889, died on January 28th, 1915. Mr. Worthington was elected a member in 1863, and died on February 8th, 1915.

Professor HALDANE GEE, B.Sc., M.Sc.Tech., exhibited and described a **Projection Screen invented by the late Mr.**

Thomas Thorp. It is made by producing a special type of matt surface on glass, on which is then deposited silver. This forms the opaque back of the screen, the front being of transparent glass. The screen gives a well-illuminated picture when employed for ordinary lantern work and is especially good for use with the projecting microscope. By its means the Brownian motion of colloidal particles, which requires high magnification and great loss of light, can be demonstrated whereas other types of screens were found to be of little use for this purpose. The screen is most effective when viewed at an angle nearly perpendicular to its surface. The surface brightness falls off as the angle from the normal is increased and at about 33° is only equal to that of white blotting paper. A microscopic examination of the surface shows that it is made up of minute convex discs.

Mr. HARVEY THORP described some of his father's experiments made with the view of producing improved screens for use with the Kinematograph, and Mr. ARTHUR ADAMSON explained the result of measurements which helped to explain the special optical properties of the screen.

Professor G. ELLIOT SMITH, M.A., M.D., F.R.S., read a paper entitled "**The Significance of the Geographical Distribution of the Practice of Mummification.**"

This paper will be printed in full in the *Memoirs*.

General Meeting, March 9th, 1915.

The President, Mr. FRANCIS NICHOLSON, F.Z.S.,
in the Chair.

Mr. HENRY WARD KEARNS, B.Sc., J.P., of "*Boothroyd*,"
Brooklands, near Manchester, was elected an ordinary member
of the Society.

Ordinary Meeting, March 9th, 1915.

The President, Mr. FRANCIS NICHOLSON, F.Z.S.,
in the Chair.

A vote of thanks was accorded the donors of the books upon the table. Amongst these were: "*The South Wales Tornado of October 27, 1913*," by H. Billett (Geophysical Memoirs, No. 11) (Fol., London, 1914), presented by the Meteorological Office, London; and "*Rapporten van den Oudheidkundigen Dienst in Nederlandsch-Indië, 1913*" (8vo, Batavia, etc., 1914), presented by the Bataviaasch Genootschap van Kunsten en Wetenschappen.

Sir ERNEST RUTHERFORD showed fine crystals of the radioactive mineral, autunite, which had been obtained from South Australia. Comparatively large deposits of this ore had been found by Dr. Mawson in this province.

He also demonstrated the magnetic properties of some manganese steels, kindly forwarded by Sir Robert Hadfield. By suitable treatment, part of the same specimen of iron was non-magnetic and part strongly magnetic. Such experiments illustrate in a striking way the great variations produced in the magnetic properties of iron by physical treatment.

Professor Sir ERNEST RUTHERFORD, M.A., D.Sc., F.R.S., read a paper entitled "**Origin of the Spectra given by Beta- and Gamma- rays of Radium.**"

An account was given of recent experiments of Sir Ernest Rutherford and Dr. Andrade to determine the wave length of the very penetrating gamma rays which are emitted from radium. The spectrum of the gamma rays was obtained by a photographic method by reflecting the rays from a thin slip of rock salt. The radioactive source consisted of a fine glass tube containing a large quantity of radium emanation. Special precautions were necessary to get rid of the effect of the penetrating

beta rays which are emitted with gamma rays. A large number of lines were observed in the spectrum over a wide range of wave length. Two well-marked lines are reflected from rock salt at 10° and 12° , and correspond to some soft gamma rays. There were other strong lines of 1° and 1.7° , corresponding to the very penetrating rays. The shortest wave length observed was $.07$ Ångström unit, which is about $1/50000$ of the wave length of visible light. This radiation has much the shortest wave length at present known.

An account was also given of the methods for determining the magnetic spectrum of the beta rays. For this purpose, the rays from a fine source, passing normally in a strong magnetic field, describe a circular path and fall on a photographic plate. Under these conditions, a number of well-marked lines are observed on the photographic plate, which correspond to groups of rays of definite velocity. The speed and energy of the beta particle comprising each of these groups of rays from radium products have been accurately determined by Rutherford and Robinson. The general evidence indicates that there is a very close connection between the emission of beta and gamma rays from radioactive bodies, and that the energy of the groups of beta rays are intimately related with the frequency of the gamma radiation from which they arise.

An account was given of a general theory to explain the connection between the beta and gamma rays. It is supposed that the breaking up of an atom is accompanied by the expulsion of a swift beta particle from the nucleus. This beta particle in escaping from the atom sets the external electrons in rapid vibration, and gives rise to the gamma rays observed. The radiation from the disturbed electrons may be given out either in the wave form or as swift electrons, and these two forms of energy are mutually convertible. Evidence was also given that during the disintegration of an atom, the beta particle is always expelled in a certain definite direction with regard to the structure of the atom. It was pointed out that the emission of beta and gamma rays from radioactive substances must be

regarded as part of the general radiation problem, and its importance in this connection was discussed.

Ordinary Meeting, March 23rd, 1915.

The President, Mr. FRANCIS NICHOLSON, F.Z.S.,
in the Chair.

A vote of thanks was accorded the donors of the books upon the table.

The PRESIDENT made a short communication relating to the early presence of certain birds and butterflies, observed by him on March 1st and March 8th.

Mr. T. A. COWARD, F.Z.S., F.E.S., read a paper entitled "**A Note on the behaviour of a Blackbird—a problem in Mental Development.**"

Mr. A. W. RYMER ROBERTS, M.A., read a paper entitled: "**On two cases of Parallelism in the Aphidæ.**"

These two papers are printed in full in the *Memoirs*.

Ordinary Meeting, April 13th, 1915.

The President, Mr. FRANCIS NICHOLSON, F.Z.S., succeeded by Professor G. ELLIOT SMITH, M.A., M.D., F.R.S., in the Chair.

A vote of thanks was accorded the donors of the books upon the table. These included: "*The Stela of Sebek-kpu*," by T. Eric Peet (Publication No. 75) (8vo., Manchester, 1914), presented by the Manchester Museum; "*Primary Triangulation on the 104th Meridian . . .*," by William Bowie (Special Publication, No. 19) (4to., Washington, 1914), and "*Precise Levelling from Brigham, Utah, to San Francisco*," by William

Bowie (Special Publication, No. 22) (4to, Washington, 1914), presented by the United States Coast and Geodetic Survey, Washington.

Mr. HENRY DAY, B.Sc., read a paper entitled "**Some points bearing on the Relationship of the Fishes and the Amphibia.**"

The paper deals with the three specimens of the so-called parasphenoid bone in *Rhadinichtlys monensis* from the Manchester Museum collection.

The three specimens together give an excellent idea of both dorsal and ventral surfaces of the bone so that an accurate description can be given, thus providing material for a determination of the relations and homology of this bone in the Crossopterygian fishes, and in the primitive Amphibia and Reptilia. It was shown that in all these groups the bone is really compound, consisting of parasphenoid and basisphenoid combined, and also that the bone is remarkably constant in its form and relations.

The remarkable constancy in form was contrasted with the entirely different form of parasphenoid which prevails in fossil and living Dipnoi, and was brought forward as a strong argument in favour of a development of the Tetrapoda from a Crossopterygian Ganoid stock rather than from the Dipnoi. Further, it was pointed out that in all cases this bone takes part in the suspension of the upper jaw, a process of the metapterygoid region of the palato-quadrate uniting with the basiptyergoid process of the basisphenoid region of this compound para-basi-sphenoid bone. This "pedicular" connection thus constitutes a form of autostyly common to the Crossopterygii and the primitive Amphibia and Reptilia but totally different from the autostyly found in Dipnoi, which latter type is never found in the Tetrapoda. Hence the common pedicular autostyly forms another argument in favour of a Crossopterygian derivation of the Tetrapoda as opposed to the Dipnoian derivation.

Annual General Meeting, April 27th, 1915.

The President, Mr. FRANCIS NICHOLSON, F.Z.S.,
in the Chair.

The Annual Report of the Council and the Statement of Accounts were presented, and it was resolved:—That the Annual Report, together with the Statement of Accounts, be adopted, and that they be printed in the Society's *Proceedings*.

Mr. ARTHUR ADAMSON and Mr. R. S. ADAMSON were appointed Scrutineers of the balloting papers.

The following members were elected Officers of the Society and Members of the Council for the ensuing year:—

President: SYDNEY J. HICKSON, M.A., D.Sc., F.R.S.

Vice-Presidents: FRANCIS NICHOLSON, F.Z.S.; G. ELLIOT SMITH, M.A., M.D., F.R.S.; T. A. COWARD, F.Z.S., F.E.S.; Sir ERNEST RUTHERFORD, M.A., D.Sc., F.R.S.

Secretaries: R. L. TAYLOR, F.C.S., F.I.C.; GEORGE HICKLING, D.Sc., F.G.S.

Treasurer: W. HENRY TODD.

Librarian: C. L. BARNES, M.A.

Other Members of the Council: W. W. HALDANE GLE, B.Sc., M.Sc.Tech., A.M.I.E.E.; R. F. GWYTHYR, M.A.; H. R. HASSÉ, M.A., D.Sc.; W. M. TATTERSALL, D.Sc.; FRANCIS JONES, M.Sc., F.R.S.E., F.C.S.; WILLIAM THOMSON, F.R.S.E., F.I.C., F.C.S.

Ordinary Meeting, April 27th, 1915.

The President, Mr. FRANCIS NICHOLSON, F.Z.S.,
in the Chair.

A vote of thanks was accorded the donors of the books upon the table. Amongst these were: "*The Life and Teachings*

of *William Honyman Gillespie*," by James Urquhart (8vo., Edinburgh, 1915), presented by the Trustees of Mrs. Honyman Gillespie; and "*Killing for Sport*," by B. Shaw and Others (12mo, London, 1915), presented by the Humanitarian League.

The PRESIDENT read the following communication from the Honorary Local Secretaries of the British Association:—

"British Association for the Advancement of Science.

Eighty-fifth Meeting, to be held in Manchester, September, 1915.

April 22nd, 1915.

To the President Manchester Literary and Philosophical Society (F. Nicholson, F.Z.S.).

Sir,

We beg to call your attention to the meeting of the British Association that will be held in Manchester, September 7th—11th, this year.

In consequence of the exceptional circumstances under which the Meeting will be held the programme of excursions and entertainments will be considerably reduced, but every effort will be made to maintain the high standard of scientific work reached in former years.

The Executive Committee, therefore, would be glad to receive assurance of the co-operation and assistance of the members of the Manchester Literary and Philosophical Society in the preparations for the reception of the Association.

Yours faithfully,

SYDNEY J. HICKSON,	} <i>Honorary</i>	
J. C. MAXWELL GARNETT,		} <i>Local</i>
E. D. SIMON,		} <i>Secretaries."</i>

It was resolved to intimate the willing co-operation of the Society in this matter.

Professor W. H. LANG, M.B., D.Sc., F.R.S., read papers entitled:—"**Studies in the Morphology of *Isoëtes*:—Part**

III., The structure and growth of the rhizophoric region of *I. lacustris*, and the development and arrangement of the roots. Part IV., The progressive growth of the young plant of *I. lacustris*, and the nature of the cortical extension of the stock."

In Part III., the structure of the rhizophoric lower region of the stock of *Isoëtes lacustris*; the nature of its meristematic growth; the way in which the segmentation of the growing line leads to the growth of a root-bearing surface, exposed by the progressive splitting and to the carriage outwards of the roots initiated close to the meristem are described in detail. The organisation of the central vascular axis of the rhizophore behind the meristematic line is shown to correspond remarkably to that of the stem-stele as described in Part II. The arrangement of the roots, their exogenous insertion, and the course of the root-traces are compared with the corresponding features of *Stigmaria*.

In Part IV., the progressive growth and organisation of the young plants of *Isoëtes lacustris* are traced from the stage of an advanced embryo to that at which a small plant exhibits adult characters as regards root- and leaf-arrangement. The symmetry of the plant is only evident when the second leaf and second root are developed. Further roots arise from a meristem established at the base of the vascular axis of the shoot long before any cambial activity has begun. The rhizophore continues from this meristem as a region of progressive growth, bearing roots acropetally. It may correspond strictly to the root-bearing region in *Lepidodendreae*. The primary root in *Isoëtes* is lateral to the axis of the rhizophore; the construction of the plant thus appears fundamentally distinct from the Gymnosperms and Angiosperms where the first root continues the axis of the plant and behaves as a tap-root.

The progressive cortical growth of the young plants of *Isoëtes* appears to continue uninterruptedly into that of the adult stock. In the latter it is regarded as generalised in the cortex and not limited to the secondary meristem.

Special Meeting, May 4th, 1915.

The President, Professor SYDNEY J. HICKSON, M.A., D.Sc., F.R.S.,
in the Chair.

At the Society's invitation, Dr. JULIUS MAC LEOD, Professor of Botany in the University of Ghent, delivered a Special Lecture entitled "**The Place of Science in History.**"

Ordinary Meeting, May 11th, 1915.

The President, Professor SYDNEY J. HICKSON, M.A., D.Sc., F.R.S.,
in the Chair.

A vote of thanks was accorded the donors of the books upon the table. The recent accessions to the Society's Library included: "*Flora Capensis*," Vol. V., Section ii., Part 1 (8vo., London, 1915), purchased.

"**A Report on the Dalton Diagrams**" was made by Dr. ARTHUR HARDEN, F.R.S., Professor W. W. HALDANE GEE, B.Sc., M.Sc.Tech., and Dr. H. F. COWARD.

This has been printed in full in the *Memoirs*, with the revised title "**John Dalton's Lectures and Lecture Illustrations.**" **Parts I. and II.** By Professor W. W. HALDANE GEE, B.Sc., M.Sc.Tech. **Part III.** By H. F. COWARD, D.Sc., and ARTHUR HARDEN, D.Sc., Ph.D., F.R.S.

MANCHESTER
LITERARY AND PHILOSOPHICAL SOCIETY

Annual Report of the Council, April, 1915.

The Society had at the beginning of the session an ordinary membership of 145. Since then eight new members have joined the Society, eight members have resigned, and five members, Mr. NATHANIEL BRADLEY, F.C.S., Mr. THOMAS KAY, J.P., Mr. R. B. LONGRIDGE, M.I.Mech.E., Mr. THOMAS THORP, F.R.A.S., and Mr. S. B. WORTHINGTON, M.Inst.C.E., M.I.Mech.E., have died. There are, therefore, at the end of the session, 140 ordinary members of the Society. The Society has also lost, by death, four honorary members, viz.: Mons. E. H. AMAGAT, For. Mem. R.S., Professor JAMES GEIKIE, D.C.L., F.R.S., Professor EDUARD SUESS, Ph.D., For. Mem. R.S., and Professor AUGUST WEISMANN, For. Mem. R.S. Memorial notices* of these gentlemen will appear with this report in the *Memoirs and Proceedings*.

Twenty-five papers have been read at the meetings during the year; eleven shorter communications have also been made.

The Society commenced the session with a balance in hand, from all sources, of £548. 2s. 11d., made up as follows:—

At credit of General Fund	£31 11 4
„ „ Wilde Endowment Fund...	249 14 6
„ „ Joule Memorial Fund.....	266 17 1

Balance 31st March, 1914.....	£548 2 11

* The memorial notice of Mr. Thomas Thorp appeared with the Annual Report for 1914.

The balance in hand at the close of the session amounted to £462. 1s. 1½d., the amounts standing at credit of the various accounts on the 31st March, 1915, being:—

At credit of General Fund.....	£	24	2	2½
„ „ Wilde Endowment Fund...		353	4	5
„ „ Joule Memorial Fund		84	14	6
		<hr/>		
Balance 31st March, 1915.....	£	462	1	1½
		<hr/> <hr/>		

The Wilde Endowment Fund, kept as a separate banking account, shows a balance due to the Fund of £353. 4s. 5d. in its favour, as against a balance in hand of £249. 14s. 6d. at the end of the last financial year. The receipts for the year 1914-15 show a slight decrease as compared with those for the previous year.

£188 17s. 3d. of the capital of the Joule Memorial Fund has been invested in the purchase of £200 of the War Loan.

The Librarian reports that during the session 785 volumes have been stamped, catalogued and pressmarked; 705 of these were serials, and 80 were separate works. 234 catalogue cards were written, 153 for serials, and 81 for separate works. The total number of volumes catalogued to date is 36,367, for which 12,647 cards have been written.

The library continues to be satisfactorily used for reference purposes. 201 volumes have been borrowed from the library during the past year. The number of books borrowed during the previous year was 285, and during 1911-12, 238.

During the year 288 volumes have been bound in 194 covers. In the previous session the corresponding numbers were 267 volumes in 185 covers.

The additions to the library for the session amounted to 705 volumes, 643 serials, and 62 separate works. The donations (exclusive of the usual exchanges) were 61 volumes; 1 volume was purchased, in addition to those regularly subscribed for.

The Radcliffe Library, Oxford, and the Bureau of the Annual International Tables of Constants and Numerical Data, Liverpool, have been placed on the list of Institutions to which the Society's publications are presented.

By the purchase of volumes 2 to 10, inclusive, of *The Entomologist*, the Society's set of this journal is now complete from volume 2.

The donations to the Society's Library during the session include gifts of books by the American Philosophical Society, Philadelphia, the Trustees of the British Museum (Natural History), the Royal Observatory, Greenwich, the Hertfordshire Natural History Society, the Meteorological Office, London, the Patent Office Library, London, the Radcliffe Observatory, Oxford, and Mr. Henry Sidebottom.

The publication of the Society's *Memoirs and Proceedings* has been continued under the supervision of the Editorial Committee.

The Society is indebted to Mrs. E. Tootal Broadhurst for the gift of an engraving of Elihu Burritt.

A number of original pen-and-ink diagrams, used by Dr. John Dalton, were found, during the summer, in the Society's rooms. A Report on these diagrams is in course of preparation and will be communicated to one of the Meetings of the Society at an early date.

Owing to the war, certain continental journals, subscribed for by the Society, have not been received. The exchange of publications with many Societies is also necessarily interrupted.

At the Society's invitation, Dr. Julius Mac Leod, Professor of Botany in the University of Ghent, will deliver a special lecture before the Society on May 4th. The title of the lecture will be "The Place of Science in History."

The Annual Dinner will not take place this year.

The Treasurer has been nominated to represent the Society on the "Faunal Survey of Lancashire and Cheshire" Committee.

The Special Library Committee, as a result of a series of meetings, reported:—(a) that a number of volumes, of little value, in the Society's library should be disposed of; (b) that, on examination, the scientific apparatus in the Society's possession was found to include many valuable pieces of which the history appears to be unknown.

They recommended:—

The preparation of a catalogue of the non-serial publications in the Society's library; the disposal of such volumes as appear to be of no value to the Society; the preparation of a card-catalogue of the pieces of scientific apparatus, portraits, busts, etc., in the Society's possession; the rejection of such pieces of apparatus as are neither of material nor historic value; and the expenditure of a small sum of money on various matters arising out of the above recommendations.

The recommendations were adopted by the Council.

The Committees appointed by the Council during the year were as follows:—

House and Finance.

The PRESIDENT.	Professor S. J. HICKSON.
Mr. FRANCIS JONES.	Mr. W. H. TODD.
Mr. C. L. BARNES.	Dr. H. G. A. HICKLING.
Mr. R. L. TAYLOR.	

Editorial.

The PRESIDENT.	Mr. R. F. GWYTHYR.
Professor S. J. HICKSON.	Mr. R. L. TAYLOR.
Dr. H. G. A. HICKLING.	The ASSISTANT SECRETARY.

Wilde Endowment.

The PRESIDENT.	Mr. W. H. TODD.
Mr. FRANCIS JONES.	Mr. R. L. TAYLOR.
Dr. H. G. A. HICKLING.	

Special Library Committee.

The PRESIDENT.	Mr. FRANCIS JONES.
Professor S. J. HICKSON.	Mr. C. L. BARNES.
Professor W. W. HALDANE GEE.	Mr. R. F. GWYTHYR.
Mr. R. L. TAYLOR.	Dr. H. G. A. HICKLING.
The ASSISTANT SECRETARY.	

EMILE-HILAIRE AMAGAT was born in 1840, and after holding several minor appointments became a professor at the Ecole Normal, Cluny, in 1867. He was subsequently elected to a similar appointment at the Catholic University, Lyons, and might have had a professorship at the Ecole Polytechnique, at Paris, but preferred to remain examiner to that institution.

Like Regnault, Natterer, Andrews, Despretz, and Cailletet, he became interested in the product p_v as applied to fluids, but obtained accurate results on a more heroic scale than they. He utilised a church tower at Cluny for supporting a mercury

column, giving pressures up to 80 atmospheres, and afterwards the shaft of a coal mine at St. Etienne, whereby he reached 430 atmospheres. These not sufficing, he devised forms of manometer and piezometer, giving pressures up to 3,000 atmospheres. The difficulties of such experiments are very great, since the volume of a glass or metal vessel exposed to an enormous pressure on one or both surfaces is not calculable by ordinary methods, nor can the pressure itself be found without such knowledge. There are also personal risks to be undergone, but of these he took no account.

His most important papers are *Recherches sur la compressibilité des gaz, de l'air, et de l'acide carbonique*; *Sur une forme de la relation $F(vpt) = 0$ relative aux gaz et sur la dilatation de ces corps, à volume constant* (Annales de Chimie et de Physique, 1883); *Recherches sur l'élasticité des solides et la compressibilité du mercure* (Ib., 1891); and *Mémoires sur l'élasticité et la dilatabilité des fluides jusqu' aux très hautes pressions* (Ib., 1893).

The gases upon which he worked were oxygen, hydrogen, nitrogen, air, carbonic acid, and ethylene, and the liquids, water, ether, alcohol, aldehyde, propyl alcohol, allyl alcohol, acetone, ethyl chloride, ethyl bromide, ethyl iodide, carbon disulphide, and phosphorus tri-chloride. His results were accepted without question and have been quoted in text-books for nearly a quarter of a century.

Amagat was elected an honorary member of the Society in 1892; five years later the Royal Society made him a foreign member, and in 1902 he became a member of the Académie des Sciences. During the last few years he had retired from work owing to ill-health, and he died early in March, at Saint-Satur, in the Department of Cher. His nature is described as sincere, kindly and modest.

C. L. B.

Mr. NATHANIEL BRADLEY, J.P., F.C.S., who became a life-member of the Society in 1889, died on the twenty-eighth of January, 1915. Mr. Bradley was apprenticed as a youth to a

cabinet-maker in Bolton-le-Moors, Lancashire, his native town, but in 1849 he sailed for New York and, shortly afterwards, his father having joined him, they formed a homestead society along with several other Englishmen, and purchased land near Milwaukee, in the State of Wisconsin, U.S.A., where a number of English families are still settled. Mr. Bradley then bound himself to a carver of wood and stone in Philadelphia, and, as a carver, travelled considerably in the United States. At this time, he spent his leisure hours in nature study and in science (as taught in those days), more especially in the study of chemistry.

Returning to England, Mr. Bradley became in 1857 a student at the old Mechanics' Institute, from which the Manchester School of Technology has descended, and ultimately passed an examination, being one of the ten successful candidates out of the 160 examined, which gave him the position of student-analyst in the Government Inland Revenue Laboratory at Somerset House, London. Here he had a three years' course of study under Professor Hofmann and other well-known scientists, at the end of which he was one of the three First Prizemen, obtaining $97\frac{1}{2}$ per cent. of the total marks awarded. He thus became a fully qualified analytical chemist in the civil service, and on several occasions he was sent by the Department to different parts of Great Britain and Ireland to visit the various distilleries, breweries and other manufactories and report upon the materials used and the product obtained with a view to the detection of adulterants. Equipped with this experience, he retired from the civil service, and became a consulting, analytical and manufacturing chemist and a successful inventor, one of his inventions, which had a large sale and is still used, being an apparatus for purifying pitching yeast for use in the process of brewing. When living in London Mr. Bradley joined the Chemical Society, ultimately becoming a life-member, and was in frequent attendance at its monthly meetings along with Richard Bannister, W. H. Perkin, H. E. Roscoe, T. E. Thorpe, and other distinguished chemists of those days.

Returning to Manchester, where he set up in business, his knowledge of the chemistry of brewing led to his election as honorary analyst to the Manchester Brewers' Association—a position which he relinquished on being appointed a justice of the peace and a member of the Licensing Bench, of which he was for many years the deputy-chairman.

For the Manchester Brewers' Association he delivered, in 1877, a series of lectures on the cultivation of yeast, in which he expounded and elaborated the studies of M. Pasteur; and he also lectured to the same society on diseases in beer. For his colleagues on the Licensing Bench, he made a special report on medicated wines, which is still used as a text-book by the licensing department.

As a member of the Rivers Committee of the Manchester City Council, he made an exhaustive study of the purification of sewage, and as chairman of the Manchester Justices Gas Meter Testing Committee—a position he held for the fifteen years preceding his death—he was instrumental in introducing the index-test, and was a firm supporter of the movement for providing apparatus for measuring high-pressure gas.

He married in 1859 Melicent, the elder daughter of Thomas Estcourt, a relative of the Sotheran-Estcourts, his eldest son being F. E. Bradley, M.A., M.Com., LL.D.—a former pupil of Francis Jones and H. E. Roscoe—who was once the principal assistant in Mr. Bradley's laboratory and, under his direction, carried out the experiments which led to Mr. Bradley's discoveries.

B.

JAMES GEIKIE.—The great ice-age of Pleistocene times, during which half of North America and more than half of Europe were converted into Arctic wastes, will always be associated with the name of JAMES GEIKIE. Born in Edinburgh on the 23rd of August, 1839, educated in the High School and University of the same city, Geikie remained to the end of his days an Edinboro' man, and fitly upheld the great traditions of geological investigation which are the city's heritage from Hutton and Jameson.

He left the University in 1861 to become an officer of the Geological Survey of Scotland, ever notable as a training-ground of great geologists. Being turned by chance to the mapping of the superficial deposits of sand and boulder-clay in Southern Scotland, his interest was soon aroused in the varied problems of glaciation, and his life-work fixed. Within thirteen years, in 1874, he produced the first comprehensive work on glacial geology, the "Great Ice Age," which remains to this day as the classic of the subject. The volume has grown with years, and its third edition, of 1894, must always rank as one of the great text-books of geological science.

In 1882 he was called to the chair of Geology in his old University, and quickly established a reputation as a teacher—a field of activity in which he exhibited exceptional qualification. Fortunately he was gifted with a facility with the pen no less than that he showed in the class-room, and the geological student will long be indebted to his writings. In particular, he established a standard in the illustration of his works far in advance of any previously attained by other authors. While the formal student will ever be grateful for such works as "The Outlines of Geology" and the beautiful "Structural and Field Geology," the general reader is equally indebted for the "Ice Age," "Prehistoric Europe," "The Antiquity of Man," and "Mountains, their Origin, Growth and Decay." In addition to these larger works, numerous smaller studies such as "Earth Sculpture" add greatly to his valued contributions to science and literature.

Geikie's work as a teacher was far from limiting his services in the University. He was one of its most active administrators, and the value placed on his services by his colleagues is amply testified by the fact that he was retained in the post of Dean of the Faculty of Science from the time of its foundation till his resignation of his professorship, followed so shortly by his lamented death.

Scarcely less valued than his service to geology was his constant effort for the reform of geographical study and teaching.

He was largely instrumental in founding the Scottish Geographical Society in 1884, and for several years acted as its President.

So recently as June, 1914, he resigned his Chair of Geology, in the hope of spending some years still in the furtherance of his beloved subject, only to be lost after a brief illness on the 1st of March, 1915, deeply mourned by all who knew him. G. H.

THOMAS KAY, J.P. Born at Heywood on the 6th March, 1841. Died at his residence, Moorfield, Stockport, on the 22nd September, 1914, in his 74th year.

He was educated at the Bury Grammar School. In 1856 he was apprenticed to Mr. James Greenough, chemist and druggist, of Heywood.

After acting as assistant to chemists in various towns, he went to London in 1863 to the position of retail manager to Mr. Peter Squire, chemist to Her Majesty, in Oxford Street.

In 1866 he joined his brother, now Mr. Samuel Kay, J.P., in founding the firm of Kay Brothers, at Lower Hillgate, in Stockport. The firm was very successful, many of their Pharmaceutical preparations gaining world-wide repute. Subsequently the business was removed to St. Petersgate, Stockport, and made into a private Limited Company.

Mr. Kay never forgot his early days at Heywood and gave many liberal gifts to the Bury Grammar School and to the town.

In October, 1912, they presented him with the freedom of the Borough of Heywood, and he became the first Honorary Freeman.

He married Ellen, daughter of James Downs, of Stockport, who died on the 13th September, 1879. His only child, Harold, predeceased his father by about two years.

He founded and presented to his native town of Heywood an Art Gallery and Museum, along with many pictures by the Old Masters and some of the Modern School, and a fine collection of crystals and some antiques. The Art Gallery and Museum were opened in July, 1912.

He composed some very creditable poems, and the late Dr. E. Watson and Mr. T. Darman Ward assisted and collaborated in setting some of his verses to music.

During the 50 years he resided in Stockport, he associated himself with various movements of an educational, philanthropic and social character. He found pleasure and delight in helping others unostentatiously and by stealth, from the large fortune which he accumulated through his genius and enterprise.

He aided promising students by enabling them to obtain University education: there is scarcely an institution in the town which has not benefited by his generosity, and many large gifts which were announced as anonymous were known by a few to have come from him.

Two institutions specially received his support—the Stockport Infirmary (of which he was Chairman at the time of his death) and the Technical School (of which he was one of the Committee who founded it at a cost of £18,000), to which he largely contributed. He remained a member of the Committee, and during his Mayoralty he laid the foundation stone of an extension of the same building.

He discovered and presented the original “Grafton Portrait of Shakespeare” to the Rylands Library,

In 1912 he was unanimously elected Mayor of Stockport, with his grand-daughter, Hilda Winifred Kay (who was in her seventeenth year) as Mayoress. Till then he had taken no part in municipal work.

During his Mayoralty his hospitality was shared by a large number of people, including the school children and the Corporation employees.

He acted as Honorary Treasurer in raising £10,000 for the King Edward VII. Memorial, and he himself contributed largely to the fund.

In 1902 he founded that splendid educational institution the Maia Choir and Classes, which has been the means of spreading a love of good music in hundreds of homes in

Stockport and district. He was a great lover of music. He said on one occasion, "it is like mercy—it is twice blessed—it blesses him that gives and him that takes." As giving an insight into his life may be quoted his composition :—

"The Dream of Rest."

Music by the late Dr. Henry Watson.

Dull and drear is the waning year, meeting its end at last.
 Sweet and low is the evening glow, after the storms are past.
 The friends we love now gone before, the days' long work now
 done,
 Dark is the prospect of the night, when light and love are gone.
 Oh for the wings of angels' light, mounting to realms of bliss,
 Soaring to the sun's great orb and brighter worlds than this
 The future life and new domain, the sage's dream of rest,
 Set as a jewel in the sky, resplendent for the blest.

Mr. Kay was appointed a Stockport Borough Magistrate in 1886, and a County Magistrate in 1907. In politics he was a liberal and for some time was President of the Stockport Liberal Association. He was a Governor of the Pendlebury Charity for Orphans; a Governor of the Stockport Grammar School; an ex-President of the Stockport Cricket Club; one of the Ephraim Hallam Trustees; a founder of the Stockport Lads' Club; a Past-President of the Stockport Naturalists' Society and Photographic Society and of the Stockport Field Club; President of the Students' Sketching Club; Vice-President of the Manchester Literary Club; Founder of the Manchester Pharmaceutical Association Scholarship; President of the Manchester Glee Club.

There was no end to Mr. Kay's activities in the realms of literature, science and art. He had an artistic instinct which found expression in verse, in song, and on canvas.

He was a great traveller, almost every year visiting the art centres of Europe and picking up objects of art and other treasures. In this way he got together the splendid collection

which he presented, together with the Art Gallery and Museum, to his native town of Heywood.

Mr. Kay took a keen interest in archæology, geology, botany and natural science.

He was a man of strong individuality, quick in action; no sooner had he decided to do something than he at the same moment commenced to materialise it. His business success seems to have been largely due to his rapidity of conceiving and carrying out any scheme which suggested itself to him. If he received a letter, the answer was generally penned and made ready for the post before the letter left his hand and within a few minutes of its receipt. In travelling, he always carried with him his sketching pads and colours, and when he found an interesting subject he sketched it in a few minutes and afterwards completed it, and many of his pictures are truly works of art. He often regretted that he had not spent his whole life as an artist.

A few lines from a character sketch, written under the title, "Stockport's New Mayor," may be cited:—

"Hearty, hospitable Thomas Kay has accepted the invitation of the Stockport Council Who in Stockport does not know that broad smiling face, does not recognise the bluff old-English style of the easy-going and warm-hearted man whose name is a synonym for philanthropy and good deeds; anyone at first glance would pronounce Thomas Kay as a typical Briton. He does not stand on ceremony, does not mince his words, does not dilly-dally in his undertakings. He knows exactly what to do and does it. He is a keen business man, a scientist of no mean repute, and a patron of the arts."

W. T.

ROBERT BEWICK LONGRIDGE, the fourth and last surviving son of Michael Longridge, Esquire, J.P., was born at Bedlington, in Northumberland, on the 2nd January, 1821. He received his education at Grange School, Sunderland, from private tutors, and at Edinburgh University. After leaving the University he

returned to Bedlington to manage the Locomotive Factory at the Bedlington Iron Works, which at that time belonged to his father. In connection with the business of the works he travelled in Belgium, France, Spain, Germany and Russia, and acquired a working knowledge of the languages of all these countries except the last.

He retained the management of the Locomotive Factory till it was closed in 1853. In 1848 he married Elizabeth Selby, daughter of Colonel Thomas Stirling Begbie, 82nd Regiment; by whom he had one son and two daughters.

On the death of his wife in 1853 he left Bedlington, and in the following year began the work with which his name will always be associated, by becoming the first Chief Inspector of an Institution, founded by Fairbairn, Whitworth, Houldsworth and others, which is now known as the Manchester Steam Users' Association for the prevention of Boiler Explosions and the Attainment of Economy in the Application of Steam.

Mr. Longridge devoted his chief attention to the last-named object, but when the penalising law against insurance was removed, the Association would not offer these advantages to its members and he therefore resigned his appointment in 1859, and, in conjunction with William McNaught, Charles S. Galloway, and others, established the Steam Boiler Assurance Company (subsequently the Boiler Insurance and Steam Power Company and now the Vulcan Boiler and General Insurance Company), of which he became Chief Engineer.

In its turn this Company refused to extend insurance to engine damages and in 1878 Mr. Longridge left it to found the Engine Boiler Insurance Company (now the British Engine, Boiler and Electrical Insurance Company), to inspect Engines and Electrical Machinery, as well as Boilers, and insure them against "break-down." He remained the Chairman of this Company till 1911. He carried out some valuable experiments on the strength of riveted joints which were published by his company. He died peacefully on the 31st July, 1914, full of years and honoured by all who knew him. Many of these have passed away, but the

writer of this Memoir, whose business has brought him into contact with steam users in all parts of the kingdom, has been much impressed by the respect still paid to his name by many whose personal intercourse with him must have ceased years ago.

Mr. R. B. Longridge was elected a member of the Institution of Mechanical Engineers in 1856 and of this Society in 1857. He was a Justice of the Peace for the County of Chester, and for some time Chairman of the Petty Sessional Division of Bucklow, but relinquished that position about twelve years before his death.

C. E. S.

EDUARD SUESS passed away on the 26th of April, 1914, his death robbing the geological world of the greatest figure of recent days. The lives of all great men are characterised by unity of purpose, and the life of Suess was devoted to the reconstruction of the past history of the earth's surface. He was not a great contributor to the facts of science, though a man of the widest observation; his genius was the power to see details in their true proportion and to unite the work of other men into a consistent whole. Thus it comes to be that all his studies are given to the world in one immortal work, the "Antlitz der Erde." Other men have given us compilations; in Suess's volumes the facts are the stones of a masterly building.

A man is known not only by his works, but still more fully by his disciples; and on this count Suess again stands pre-eminent. To name only one or two of the most notable, among his pupils are to be counted Waagen, Neumayr and Judd, and it is noteworthy that his students became famous, and leaders in their turn, in every branch of geological study. Indeed it may safely be contended that no man exercised a more profound influence on the development of geological thought, while his teaching has founded a new science of Geography.

Born in London on August 20th, 1831, Suess was taken in early childhood to Prague. He was educated in the university of that city and later at Vienna, where the remainder of his life

was spent. His early studies were palæontological, growing by natural extension to embrace the greater problems of stratigraphy and reaching a climax in the investigation of the mechanism of evolution of the earth's surface.

Honoured as he was by all the world, this Society did itself honour in electing him to its membership on April 30th, 1895.

G. H.

AUGUST WEISMANN.—By the death of August Weismann on November 5th, 1914, we have lost one of the most distinguished investigators and profound thinkers in the field of Biological Science. Like many others who have had the courage to express their conceptions of the principles that regulate the evolutionary processes of animals and plants, Weismann was not able to gain recognition as a leading authority without a storm of controversy and criticism. Both in his own and foreign countries his theoretical ideas met with severe and often ill-natured opposition, but throughout his long career he never failed to maintain the high standard of scientific research and discussion characteristic of a really great philosopher. As time passes, some of his earlier conceptions may seem to us crude and unsatisfactory, but we must realise that in his day Weismann had the genius to arouse world-wide interest in his work, to stimulate inquiry and to provoke discussion. In this respect at least there were few men of his period that were his equal.

Born on January 17th, 1834, at Frankfort-on-the-Main, where his father was a Professor in the Gymnasium, he became a student of medicine in Göttingen and afterwards of zoology at Giessen. He became Professor Extraordinarius at Freiburg in Breisgau in 1866 and Professor Ordinarius there in 1873. On more than one occasion he had a call to a chair in a larger and more important University in the German Empire, but he remained at his post in Freiburg to the end.

It is quite impossible in a short notice to do justice to the extraordinarily wide and varied interests of his life's work nor to the richness of the ideas which brightened and enriched his

writings on many detailed and highly technical subjects. His earlier papers on the development of the house-fly and on the natural history of the Daphnids and Ostracods, although of very high quality and interest, were overshadowed in importance by the publication in 1883 of his great work on the "Origin of the Sexual Cells in the Hydromedusae." It was in this thesis that his conception of the immortal germ plasm that passes on from generation to generation, immune from the need for that periodic death the body-plasm requires, was first adumbrated; and from this conception arose the long series of philosophical speculations which has given rise to the expression "Weismannismus."

As a young student of the morphology of the Coelenterata at the time of the publication of "Die Entstehung," the writer can well remember the powerful influence this paper had, not only on our ideas of the living body of animals in general, but also on our conceptions of the relation between the "medusom" and "hydrosom" stages of the Hydromedusae. The careful and skilled microscopical study, the orderly sequence of the points and the final conclusive arguments that seemed to settle the matter under discussion once and for all time raised this great work to the level of a classic, which we read with interest and enthusiasm. The essays on the "Duration of Life" and on "Life and Death," which appeared about the same time, soon became the subjects of eager discussion in the junior scientific societies of the early eighties, and opened up new fields for original work and speculation among the young zoologists.

At the beginning of the Long Vacation of 1884 the writer, attracted by the fame of Weismann, paid a visit to Freiburg and spent a few weeks there working in the zoological laboratory. He can remember well the charm of Weismann's personality, his interest in the work of the German and of the many foreign students who were engaged in researches under his directions and the stimulus of his lectures and conversation.

Weismann came to Manchester in 1887 to attend the meeting of the British Association, and was the guest of his former pupil, Dr. G. H. Fowler, in York Place, at the time a Berkeley

Fellow in the Owens College. It was a significant fact of the great reputation already acquired by Weismann that among the many distinguished zoologists from all parts of the world, including Carnoy, Wiedersheim, Hubrecht, Giard, and many others, Weismann was selected as the principal guest at a dinner held in the Albion Hotel during the meeting of the Association. He was elected an Honorary Member of the Manchester Literary and Philosophical Society on April 17th, 1894.

To those among our countrymen who enjoyed his personal friendship and were indebted to him for many personal kindnesses, it came as a shock to learn that in his old age and enfeebled health he publicly renounced this and the many other honours and distinctions with which he had been endowed by English scientific societies, but when the hate and glamour of war has passed away, the memory of Weismann must remain as one of the great figures of his generation. S. J. H:

SAMUEL BARTON WORTHINGTON, Railway Engineer, was born at Stockport on the 4th December, 1820. His early home, except for the first few months, was in Manchester—first in Salford, then in Broughton, the boy attending successively the schools of the Revs. Edward Hawkes, and J. R. Beard.

At sixteen he began his training as an engineer, and for six years was a pupil of Joseph Locke, friend and fellow-worker of Stephenson, thus being in the very thick of the railway rush of that time.

As a boy, in 1830, he had seen the opening of the Liverpool and Manchester Railway and in 1836, the first year of his apprenticeship, he rode with Robert Stephenson (son of George Stephenson) on the very first engine 'the Zaniel' which took a passenger train from Birmingham to Liverpool, Mr. Joseph Locke driving the engine part of the way. He was also on the first engine which went through the Penistone tunnel on the railway from Manchester to Sheffield. But most remarkable of all was the responsible share he had in the making of the first French railway between Rouen and Paris. From 1840 he was

for three years resident in Paris, and one of his vivid memories of that time was of seeing in the Seine the black-draped vessels which had just brought the remains of Napoleon from St. Helena.

On his return to England he was engaged in the construction of the Lancaster and Carlisle Railway, and on the completion became Resident Engineer of the line with his home at Lancaster. That position he retained when his line was merged in the greater undertaking in the London and North Western Railway, and he was Chief Engineer of the Northern Division of the line until his retirement in 1885. After this date he became for a short time a consulting engineer, but devoted nine years voluntary service to the work of the Manchester Town Council. He sat for Exchange Ward, and did very good work on the Waterworks and Rivers Committees, on which he was able to speak with the authority of experience. It is very rarely that town councils can secure men of this calibre.

“He was an enthusiast for his profession and, both by tradition and experience, keen on upholding the highest standard of professional conduct, and was always an advocate both in public and in private, of the necessity of sound scientific knowledge as a basis for the more strictly technical training of an engineer. To the last he followed with interest and approval the progressive steps taken by ‘The Institution of Civil Engineers’.”

Though our obituary notices are usually restricted to the scientific side of a member's life we feel that some allusion should be made in Mr. Worthington's case to the remarkable wideness of his interests. “From the Rev. Edward Hawkes he acquired a knowledge of the classics which was a pleasure to him throughout a long life—within a short time of his death he was reciting Horace—while from Dr. Beard to whose school in Broughton he went for a few years after Mr. Hawkes went to Kendal—and from the excellent teachers of that school he obtained a knowledge of Mathematics, Chemistry, and Geology which was not obtainable in many schools of that time. Throughout his life he was a great reader and had, for a man in active professional practice, a most

unusual acquaintance with the writings of philosophers (especially Martineau)."

Mr. Worthington was elected a member of this Society 17th November, 1863.

Though he attended our meetings occasionally he only made two communications which were as follows:—

"On a swing Bridge with girders made of Bessemer steel plates" (1865), *Proc.*, IV., p. 77.

"Exhibit of a piece of soft cast iron taken out of the Sankey canal" (1865), *Proc.*, IV., p. 78.

Mr. Worthington died at his house in Bowdon on Monday, February 8th, 1915, after only one day's illness, in his 95th year, the funeral taking place on the following Thursday at Hale Chapel.

F. N.

NOTE.—The Treasurer's Accounts of the Session 1914-1915 have been endorsed as follows :

April 17th, 1915. Audited and found correct.

We have also seen, at this date, the certificates of the following Stocks held in the name of the Society:—£1,225 Great Western Railway Company 5% Consolidated Preference Stock, Nos. 12,293, 12,294, and 12,323; £7,500 Gas Light and Coke Company Ordinary Stock (No. 8/1960); £100 East India Railway Company's 4% Annuity Stock (No. 4032); and the deeds of the Natural History Fund, of the Wilde Endowment Fund, those conveying the land on which the Society's premises stand, and the Declarations of Trust.

Leases and Conveyances dated as follow:—

22nd Sept., 1797.

23rd Sept., 1797.

25th Dec., 1799.

” ” ”

22nd Dec., 1820.

23rd Dec., 1820.

Declarations of Trust:—

24th June, 1801.

23rd Dec., 1820.

8th Jan., 1878.

Appointment of New Trustees:—

30th April, 1851.

We have also seen Bankers' acknowledgment of the investment of £200 in the War Loan.

We have also verified the balances of the various accounts with the bankers' pass books.

(Signed) { D. THODAY.
E. L. RHEAD.

MANCHESTER LITERARY AND

Dr.

W. Henry Todd, Treasurer, in Account with

		£	s.	d.	£	s.	d.
To Balance, 1st April, 1914					298	8	
To Members' Subscriptions:—							
Half Subscriptions, 1910-11, 1 at £1. 1s. od.		1	1	0			
" 1911-12, 1 " " "		1	1	0			
" 1912-13, 1 " " "		1	1	0			
" 1913-14, 3 " " "		3	3	0			
" 1914-15, 15 " " "		15	15	0			
" 1915-16, 1 " " "		1	1	0			
Subscriptions:—							
1912-13, 2 " £2. 2s. od.		4	4	0			
" 1913-14, 12 " " "		25	4	0			
" 1914-15, 98 " " "		205	16	0			
To Transfers from the Wilde Endowment Fund							258 6
To Sale of Publications							83 12
To Dividends:—							9 4
Natural History Fund		56	10	7			
Joule Memorial Fund		6	2	5			
To Income Tax Refunded:—							62 13
Natural History Fund		3	12	9			
Joule Memorial Fund		0	12	3			
Wilde Endowment Fund		21	13	5			
To National Health Insurance Act deductions							25 18
							2 7

£740 9 13

NATURAL HISTORY

	£	s.	d.
To Dividends on £1,225 Great Western Railway Company's Stock	56	10	
To Remission of Income Tax, 1914	3	12	
To Balance against this Fund, 1st April, 1915	17	5	
			£77 8

JOULE MEMORIAL

	£	s.	d.
To Balance, 1st April, 1914	266	17	
To Dividends on £100 East India Railway Company's 4% Annuity Stock	5	14	
To Interest on £200 War Loan	0	8	
To Remission of Income Tax, 1914	0	12	
			£273 11

WILDE ENDOWMENT

	£	s.	d.
To Balance, 1st April, 1914	249	14	
To Dividends on £7,500 Gas Light and Coke Company's Ordinary Stock	330	14	
To Remission of Income Tax, 1914	21	13	
To Bank Interest	4	13	
			£606 2 2

PHILOSOPHICAL SOCIETY.

Statement, from 1st April, 1914, to 31st March, 1915.

Cr.

	£	s.	d.	£	s.	d.
Charges on Property :—						
Chief Rent (Income Tax deducted)	11	18	6			
Income Tax	1	1	5			
Insurance against Fire	11	0	0			
House Expenditure :—				23	19	11
Coals, Gas, Electric Light, Water, &c.	35	10	5			
Tea, Coffee, &c., at Meetings	10	16	0			
Cleaning, Sweeping Chimneys, &c.	3	18	1½			
Replacements of mantles, crockery, dusters, ironware, etc.	6	19	0			
Whitewashing, repairs, etc.	1	15	11			
Administrative Charges :—				58	19	5½
Housekeeper	65	0	0			
Postages, and Carriage of Parcels and of "Memoirs"	30	16	0½			
Stationery, Cheques, Receipts, and Engrossing	8	0	8			
Printing Circulars, Reports, Articles of Association, &c.	24	4	6			
Extra attendance at Meetings, and during housekeeper's holidays	2	16	6			
Insurance against Liability	0	12	0			
National Health Insurance Stamps	4	6	8			
Miscellaneous Expenses	1	17	8			
Renovation of Dalton Diagrams				137	14	0½
Publishing :—				2	7	6
Printing "Memoirs and Proceedings"	134	15	7			
Illustrations for "Memoirs" (except Nat. Hist. papers)	5	6	9			
Library :—				140	2	4
Books and Periodicals (except those charged to Natural History Fund)	9	18	9			
Periodicals formerly subscribed for by the Microscopical and Natural History Section	3	7	6			
Catalogue Cards	1	0	0			
Natural History Fund :—				14	6	3
(Items shown in the Balance Sheet of this Fund below)				43	13	0
Joule Memorial Fund :—						
(Item shown in the Balance Sheet of this Fund below)				188	17	3
Wilde Endowment Fund (Income Tax refunded)				21	13	5
Balance at Williams Deacon's Bank, 1st April, 1915	98	16	8			
„ in Treasurer's hands	10	0	0½			
				108	16	8½
				£740	9	10½

FUND, 1914—1915. (Included in the General Account, above.)

	£	s.	d.
Balance against this Fund, 1st April, 1914	33	15	5
Natural History Periodicals	14	10	8
Illustrations for papers on Nat. Hist. in "Memoirs"	24	1	9
Binding Periodicals	5	0	7
	£77	8	5

FUND, 1914—1915. (Included in the General Account, above.)

	£	s.	d.
£200 War Loan	188	17	3
Balance, 1st April, 1915	84	14	0
	£273	11	9

FUND, 1914—1915.

	£	s.	d.
Assistant Secretary's Salary	135	0	0
Maintenance of Society's Library :—			
Binding and Repairing Books	24	16	4
Kendal, Milne & Co., carpet	9	7	0
Transfers to Society's Funds	83	12	0
Cheque Book	0	2	6
Balance at District Bank, 1st April, 1915	353	4	5
	£606	2	3

* * A cheque for M.541 sent to Germany at the end of July has not been paid into the Bank and is therefore not included in these accounts.

THE COUNCIL
AND MEMBERS
OF THE
MANCHESTER
LITERARY AND PHILOSOPHICAL SOCIETY.

Corrected to October 12th, 1915.

President.

SYDNEY J. HICKSON, M.A., D.Sc., F.R.S.

Vice-Presidents.

FRANCIS NICHOLSON, F.Z.S.

G. ELLIOT SMITH, M.A., M.D., F.R.S.

T. A. COWARD, F.Z.S., F.E.S.

SIR ERNEST RUTHERFORD, M.A., D.Sc., F.R.S.

Secretaries.

R. L. TAYLOR, F.C.S., F.I.C.

GEORGE HICKLING, D.Sc., F.G.S.

Treasurer.

W. HENRY TODD.

Librarian.

C. L. BARNES, M.A.

Other Members of the Council.

W. W. HALDANE GEE, B.Sc., M.Sc.Tech., A.M.I.E.E.

R. F. GWYTHIER, M.A.

H. R. HASSÉ, M.A., D.Sc.

W. M. TATTERSALL, D.Sc.

FRANCIS JONES, M.Sc., F.R.S.E., F.C.S.

WILLIAM THOMSON, F.R.S.E., F.C.S., F.I.C.

Assistant Secretary and Librarian.

R. F. HINSON.

ORDINARY MEMBERS.

Date of Election.

- 1911, April 4. Adamson, Arthur, M.Sc.Tech., A.R.C.S., Lecturer in Physics in the Municipal School of Technology, Manchester. *Municipal School of Technology, Sackville Street, Manchester.*
- 1901, Dec. 10. Adamson, Harold. *Oaklands Cottage, Godley, near Manchester.*
- 1912, Oct. 15. Adamson, R. Stephen, M.A., B.Sc., Lecturer in Botany in the Victoria University of Manchester. *The University, Manchester.*
- 1870, Dec. 13. Angell, John, F.C.S., F.I.C. 6, *Beacons-Field, Derby Road, Withington, Manchester.*
- 1914, Dec. 1. Atack, F. W., M.Sc.Tech. (Manc.), B.Sc. (Lond.), A.I.C., Demonstrator in Chemistry, The Municipal School of Technology, Manchester. 88, *Claude Road, Chorltonville, Manchester.*
- 1865, Nov. 14. Bailey, Charles, M.Sc., F.L.S. *Haymesgarth, Cleeve Hill, S.O., Gloucestershire.*
- 1895, Jan. 8. Barnes, Charles L., M.A. 151, *Plymouth Grove, Manchester.*
- 1903, Oct. 20. Barnes, Jonathan, F.G.S. *South Cliff House, 301, Great Clowes Street, Higher Broughton, Manchester.*
- 1910, Oct. 18. Beattie, Robert, D.Sc., M.I.E.E., Professor of Electro-technics in the Victoria University of Manchester. *The University, Manchester.*
- 1895, Mar. 5. Behrens, Gustav. *Holly Royde, Withington, Manchester.*
- 1868, Dec. 15. Bickham, Spencer H., F.L.S. *Underdown, Ledbury.*
- 1914, Nov. 17. Bohr, Neils, Ph.D. (Copenhagen), Reader in Mathematical Physics in the Victoria University of Manchester. *The University, Manchester.*
- 1914, Dec. 1. Bowman, Frank, B.A. (Camb.), M.Sc.Tech. (Manc.), Assistant Lecturer in Mathematics, The Municipal School of Technology, Manchester. 21, *Whalley Road, Whalley Range, Manchester.*
- 1914, Feb. 10. Boyd, A. W., M.A., F.E.S. *The Alton, Altrincham, Cheshire.*
- 1875, Nov. 16. Boyd, John. *Barton House, 11, Didsbury Park, Didsbury, Manchester.*

*Ordinary Members.**Date of Election.*

- 1912, Oct. 15. Brierley, W.B., M.Sc., Lecturer in Economic Botany in the Victoria University of Manchester. *The University, Manchester.*
- 1910, Nov. 1. Broome, James S., Science Teacher in the Salford Secondary School. 18, *Seedley Park Road, Pendleton, Manchester.*
- 1886, April 6. Brown, Alfred, M.A., M.D. *Beech Hill, Hale, Cheshire.*
- 1913, Dec. 2. Brown, T. Graham, M.D., D.Sc., Lecturer in Experimental Physiology in the Victoria University of Manchester. *The University, Manchester.*
- 1889, Jan. 8. Brownell, Thomas William, F.R.A.S. 64, *Upper Brook Street, Manchester.*
- 1889, Oct. 15. Budenberg, C. F., M.Sc., M.I.Mech.E. *Bowdon Lane, Marple, Cheshire.*
- 1911, Jan. 10. Burt, Frank Playfair, B.Sc. (Lond.), D.Sc. (Bristol), Senior Lecturer in Chemistry in the Victoria University of Manchester. 15, *Oak Road, Withington, Manchester.*
- 1906, Feb. 27. Burton, Joseph, A.R.C.S. Dublin. *Tile Works, Clifton Junction, near Manchester.*
- 1894, Nov. 13. Burton, William, M.A., F.C.S. *The Hollies, Clifton Junction, near Manchester.*
- 1911, Oct. 31. Butterworth, Charles F. *Waterloo, Poynton, Cheshire.*
- 1904, Oct. 18. Campion, George Goring, L.D.S. 264, *Oxford Street, Manchester.*
- 1899, Feb. 7. Chapman, D. L., M.A., F.R.S., Fellow and Tutor of Jesus College, Oxford. *Jesus College, Oxford.*
- 1901, Nov. 26. Chevalier, Reginald C., M.A., Mathematical Master at the Manchester Grammar School. 3, *Fort Road, Sedgley Park, Prestwich, Manchester.*
- 1907, Nov. 26. Clayton, Robert Henry, B.Sc., Chemist. 1, *Parkfield Road, Didsbury, Manchester.*
- 1903, Oct. 20. Core, William Hamilton, M.Sc. *Groombridge House, Withington, Manchester.*
- 1906, Oct. 30. Coward, H. F., D.Sc., Chief Lecturer in Chemistry in the Municipal School of Technology, Manchester. *Municipal School of Technology, Sackville Street, Manchester,* and 216, *Plymouth Grove, Manchester.*
- 1906, Nov. 27. Coward, Thomas Alfred, F.Z.S., F.E.S. *Brentwood, Bowdon, Cheshire.*
- 1908, Nov. 3. Cramp, William, D.Sc., M.I.E.E., Consulting Engineer, 33, *Brazennose Street, Manchester.*

Ordinary Members.

li

Date of Election.

- 1910, Oct. 4. Crewe, F. H., Assistant Science Master in the Central High School for Boys, Whitworth Street, Manchester. *Glengarth, Woodford Road, Bramhall.*
- 1895, April 9. Dawkins, W. Boyd, M.A., D.Sc., F.R.S., Honorary Professor of Geology in the Victoria University of Manchester. *Fallowfield House, Fallowfield, Manchester.*
- 1894, Mar. 6. Delépine, A. Sheridan, M.B., B.Sc., Professor of Pathology in the Victoria University of Manchester. *Public Health Laboratory, York Place, Manchester.*
- 1887, Feb. 8. Dixon, Harold Baily, M.A., Ph.D., M.Sc., F.R.S., F.C.S., Professor of Chemistry in the Victoria University of Manchester. *The University, Manchester.*
- 1906, Oct. 30. Edgar, E. C., D.Sc., Senior Lecturer in Chemistry in the Victoria University of Manchester. *The University, Manchester.*
- 1914, Nov. 3. Edwards, C. A., D.Sc., Professor of Metallurgy and Metallography in the Victoria University of Manchester. *26, Lyndhurst Road, Withington, Manchester.*
- 1910, Oct. 18. Evans, Evan Jenkin, B.Sc., Assistant Lecturer and Demonstrator in Physics in the University of Manchester. *The University, Manchester.*
- 1914, Feb. 24. Evans, William David, M.A., Richardson Lecturer in Mathematics, The Victoria University of Manchester. *17, Harley Avenue, Victoria Park, Manchester.*
- 1912, Oct. 15. Fairlie, D. M., M.Sc. *232, Burton Road, West Didsbury, Manchester.*
- 1914, Oct. 20. Field, Allan B., M.A., B.Sc., M.I.E.E., Professor of Mechanical Engineering, The Municipal School of Technology, Manchester. *Kingslea, Strines Road, Marple, Cheshire.*
- 1912, Feb. 6. Forder, H. G., B.A., Senior Mathematical Master, Cardiff High School. *33, Wordsworth Avenue, Newport Road, Cardiff.*
- 1908, Jan. 28. Fox, Thomas William, M.Sc.Tech., Professor of Textiles in the School of Technology, Manchester University. *Gledfield, 15, Clarendon Crescent, Eccles.*
- 1912, Oct. 15. Garnett, J. C. Maxwell, M.A., Principal of the Municipal School of Technology, Manchester. *The Municipal School of Technology, Sackville Street, Manchester, and Westfield, Victoria Park, Manchester.*

Date of Election.

- 1909, Mar. 23. Gee, W. W. Haldane, B.Sc., M.Sc.Tech., A.M.I.E.E., Professor of Pure and Applied Physics in the School of Technology, Manchester University. *Oak Lea, Whalley Avenue, Sale.*
- 1907, Oct. 15. Gravely, F. H., M.Sc. *Natural History Dept., Indian Museum, Calcutta.*
- 1907, Oct. 29. Gwyther, Reginald Felix, M.A., Secretary to the Joint Matriculation Board. 24, *Dover Street, Manchester*, and *Lymm, Cheshire.*
- 1913, Dec. 16. Handley, Marion, M.A. (Birm.), Lecturer in the Municipal Day Training College, Manchester. *Himmel, Burnage Garden Village, Manchester.*
- 1911, Oct. 3. Hassé, H. R., M.A., D.Sc., Lecturer in Mathematics in the University of Manchester. 69, *Mauldeth Road, Withington, Manchester.*
- 1914, Mar. 10. Hibbert, Eva, Assoc.M.S.T., Demonstrator in Chemistry, The Municipal School of Technology, Manchester. *The Municipal School of Technology, Manchester.*
- 1907, Oct. 15. Hickling, H. George A., D.Sc., F.G.S., Lecturer in Palæontology in the Victoria University of Manchester. *Glenside, Marple Bridge, near Stockport.*
- 1895, Mar. 5. Hickson, Sydney J., M.A., D.Sc., F.R.S., Professor of Zoology in the Victoria University of Manchester. *The University, Manchester.*
- 1909, Jan. 12. Hoffert, Hermann Henry, D.Sc. (Lond.), A.R.S.M., His Majesty's Inspector of Schools. *The Gables, Stockport Road, Marple, Cheshire.*
- 1909, Nov. 2. Holland, Sir Thomas H., K.C.I.E., D.Sc., F.R.S., Professor of Geology and Mineralogy in the University of Manchester, late Director of the Geological Survey of India. *Westwood, Alderley Edge, Cheshire.*
- 1905, Nov. 14. Holt, Alfred, M.A., D.Sc., Research Fellow of the University of Manchester. *Dowsefield, Allerton, Liverpool.*
- 1896, Nov. 3. Hopkinson, Edward, M.A., D.Sc., M.Inst.C.E. *Ferns, Alderley Edge, Cheshire.*
- 1909, Feb. 9. Howles, Frederick, M.Sc., Analytical and Research Chemist. *Glenluce, Waterpark Road, Broughton Park, Manchester.*
- 1889, Oct. 15. Hoyle, William Evans, M.A., D.Sc., F.R.S.E., Director of the Welsh National Museum, Cardiff. *City Hall, Cardiff.*

• *Date of Election.*

- 1907, Oct. 15. Hübner, Julius, M.Sc.Tech., F.I.C., Lecturer in the Faculty of Technology in the University of Manchester. *Linden, Cheadle Hulme, Cheshire.*
- 1913, Oct. 21. Imms, A. D., M.A., D.Sc., F.L.S., Reader in Agricultural Entomology in the Victoria University of Manchester. *Department of Agricultural Entomology, The University, Manchester.*
- 1899, Oct. 17. Ingleby, Joseph, M.I.Mech.E. *Springfield, Holly Road, Wilmslow, Cheshire, and 20, Mount Street, Manchester.*
- 1901, Nov. 26. Jackson, Frederick. *44, Chapel Street, Salford.*
- 1914, Jan. 13. Jenkins, William Charles, F.R.A.S., Curator of the Godlee Observatory, The Municipal School of Technology, Manchester. *The Municipal School of Technology, Manchester.*
- 1911, Oct. 3. Johnstone, Mary A., B.Sc.(Lond.), Headmistress of the Municipal Secondary School for Girls, Whitworth Street, Manchester. *43, Hill Top Avenue, Cheadle Hulme, Cheshire.*
- 1878, Nov. 26. Jones, Francis, M.Sc., F.R.S.E., F.C.S. *Manchester Grammar School, and 17, Whalley Road, Whalley Range, Manchester.*
- 1915, Mar. 9. Kearns, Henry Ward, B.Sc., J.P. *Boothroyd, Brooklands, near Manchester.*
- 1903, Feb. 3. Knecht, Edmund, Ph.D., Professor of Chemistry in the School of Technology, Manchester University. *Beech Mount, Marple, Cheshire.*
- 1893, Nov. 14. Lamb, Horace, M.A., LL.D., D.Sc., Sc.D., F.R.S., Professor of Mathematics in the Victoria University of Manchester. *6, Wilbraham Road, Fallowfield, Manchester.*
- 1909, Nov. 2. Lang, William H., M.B., C.M., D.Sc., F.R.S., F.L.S., Barker Professor of Cryptogamic Botany in the University of Manchester. *2, Heaton Road, Withington Manchester.*
- 1902, Jan. 7. Lange, Ernest F., M.I.Mech.E., A.M.Inst.C.E., M.I. & S. Inst., F.C.S. *Westholme, The Firs, Bowdon, Cheshire.*
- 1911, Jan. 10. Lankshear, Frederick Russell, B.A. (New Zeal.), M.Sc. (Manc.), Demonstrator in Chemistry in the Victoria University Manchester. *The University, Manchester.*

Date of Election.

- 1910, Oct. 18. Lapworth, Arthur, D.Sc., F.R.S., F.I.C., Professor of Organic Chemistry in the Victoria University of Manchester. 26, *The Broadway, Withington, Manchester.*
- 1904, Mar. 15. Lea, Arnold W. W., M.D. 246, *Oxford Road, Manchester.*
- 1914, April 7. Lees, S., M.A., Assoc.M.S.T., Reader in Applied Thermodynamics in the Faculty of Technology, The University of Manchester. *The Municipal School of Technology, Manchester, and Brierfield, Ashley Road, Hale, Cheshire.*
- 1907, Oct. 29. Leigh, Harold Shawcross. *Brentwood, Worsley.*
- 1908, Oct. 20. Liebert, Martin, Ph.D., Managing Director of Meister Lucius and Brüning, Ltd., Manchester. 1, *Lancaster Road, Didsbury, Manchester.*
- 1912, Nov. 12. Lindsey, Marjorie, B.Sc., Research Student in the Victoria University of Manchester. 3, *Demesne Road, Whalley Range, Manchester.*
- 1912, May 7. Loewenfeld, Kurt, Ph.D. *Fern Bank, Ogden Road, Bramhall, Cheshire.*
- 1910, Oct. 18. McDougall, Robert, B.Sc. *City Flour Mills, German Street, Manchester.*
- 1905, Oct. 31. McNicol, Mary, M.Sc. 182, *Upper Chorlton Road, Manchester.*
- 1904, Nov. 1. Makower, Walter, M.A., D.Sc. (Lond.), Lecturer in Physics in the University of Manchester. *Maylands, Brook Road, Fallowfield, Manchester.*
- 1902, Mar. 4. Mandleberg, Goodman Charles. *Redclyffe, Victoria Park, Manchester.*
- 1911, Oct. 31. March, Margaret Colley, M.Sc. *The University, Edinburgh.*
- 1901, Dec. 10. Massey, Herbert. *Ivy Lea, Burnage, *Didsbury, Manchester.*
- 1864, Nov. 1. Mather, Sir William, P.C., M.Inst.C.E., M.I.Mech.E. *Iron Works, Salford.*
- 1912, Nov. 26. Melland, Edward. *Kia Ora, Hale, Cheshire.*
- 1873, Mar. 18. Melvill, James Cosmo, M.A., D.Sc., F.L.S. *Meole Brace Hall, Shrewsbury.*
- 1894, Feb. 6. Mond, Robert Ludwig, M.A., F.R.S.E., F.C.S. *Winnington Hall, Northwich, Cheshire.*
- 1912, Nov. 26. Myers, J. E., M.Sc., Beyer Fellow and Assistant Lecturer in Chemistry in the Victoria University of Manchester. 7, *Station Road, Cheadle Hulme, Cheshire.*

Ordinary Members.

lv

Date of Election.

- 1908, Jan. 28. Myers, William, Lecturer in Textiles in the School of Technology, Manchester University. 7, *Station Road, Cheadle Hulme, Cheshire.*
- 1873, Mar. 4. Nicholson, Francis, F.Z.S. *The Knoll, Windermere, Westmorland.*
- 1884, April 15. Okell, Samuel, F.R.A.S. *Overley, Langham Road, Bowdon, Cheshire.*
- 1901, Oct. 29. Petavel, J. E., B.A., D.Sc., F.R.S., Professor of Engineering in the Victoria University of Manchester. *The University, Manchester.*
- 1885, Nov. 17. Phillips, Henry Harcourt, F.C.S. *Lynwood, Turton, near Bolton, Lancs.*
- 1903, Dec. 15. Prentice, Bertram, Ph.D., D.Sc., Principal, Royal Technical Institute, Salford. *Isca Mount, Manchester Road, Swinton.*
- 1901, Dec. 10. Ramsden, Herbert, M.D. (Lond.), M.B., Ch.B. (Vict.) *Sunnyside, Dobcross, near Oldham, Lancs.*
- 1888, Feb. 21. Rée, Alfred, Ph.D., F.C.S. 15, *Mauldeth Road, Withington, Manchester.*
- 1913, Jan. 7. Renold, Hans, M.I.Mech.E. *Priestnall Hey, Heaton Mersey, near Manchester.*
- 1910, Oct. 4. Rhead, E. L., M.Sc.Tech., F.I.C., Lecturer in Metallurgy and Assaying, The Municipal School of Technology, Manchester. *Stonycroft, Polygon Avenue, Levenshulme, Manchester.*
- 1914, Nov. 3. Richardson, Harry, M.Sc., Demonstrator in Physics, The Municipal School of Technology, Manchester. 98, *Dudley Road, Whalley Range, Manchester.*
- 1912, Oct. 29. Roberts, A. W. Rymer, M.A. *The Common, Windermere.*
- 1880, Mar. 23. Roberts, D. Lloyd, M.D., F.R.S.E., F.R.C.P. (Lond.). *Ravenswood, Broughton Park, Manchester.*
- 1911, Jan. 10. Robinson, Robert, D.Sc. (Vict.), Professor in the University of Sydney, N.S.W. *The University, Syaney, N.S.W.*
- 1897, Oct. 19. Rothwell, Alderman William Thomas, J.P. *Heath Brewery, Newton Heath, near Manchester.*

Date of Election.

- 1907, Oct. 15. Rutherford, Sir Ernest, M.A., D.Sc., F.R.S., Langworthy Professor of Physics in the University of Manchester. 17, Wilmslow Road, Withington, Manchester.
- 1909, Jan. 26. Schmitz, Hermann Emil, M.A., B.Sc., Physics Master at the Manchester Grammar School. 15, Brighton Grove, Rusholme, Manchester.
- 1873, Nov. 18. Schuster, Arthur, Sc.D., Ph.D., Sec.R.S., F.R.A.S., Honorary Professor of Physics in the Victoria University of Manchester. Yeldall, Twyford, Berks.
- 1898, Jan. 25. Schwabe, Louis. Hart Hill, Eccles Old Road, Pendleton, Manchester.
- 1890, Nov. 4. Sidebotham, Edward John, M.A., M.B., M.R.C.S. Erlesdene, Bowdon, Cheshire.
- 1903, April 28. Sidebottom, Henry. Woodstock, Bramhall, Cheshire.
- 1910, Oct. 4. Smith, Grafton Elliot, M.A., M.D., F.R.S., Professor of Anatomy in the University of Manchester. *The University, Manchester.*
- 1906, Nov. 27. Smith, Norman, D.Sc., Assistant Lecturer in Chemistry in the Victoria University of Manchester. *The University, Manchester.*
- 1896, Feb. 18. Spence, David. Lowood, Hindhead, Haslemere, R.S.O., Surrey.
- 1901, Dec. 10. Spence, Howard. C/o Messrs. Peter Spence & Sons, Ltd., Manchester Alum Works, Manchester.
- 1911, Oct. 17. Start, Laura, Lecturer in Art and Handicraft in the University of Manchester. Moor View, Mayfield Road, Kersal, Manchester.
- 1897, Nov. 30. Stromeyer, C. E., M.Inst.C.E., M.Inst.M.E., M.I.&S.Inst. Steam Users' Association, 9, Mount Street, Albert Square, Manchester, and Landfield, West Didsbury.
- 1910, Oct. 18. Tattersall, Walter Medley, D.Sc., Keeper of the Manchester Museum. *The Manchester Museum, The University, Manchester.*
- 1895, April 9. Tatton, Reginald A., M.Inst.C.E., Engineer to the Mersey and Irwell Joint Committee. Manor House, Chelford, Cheshire.

Ordinary Members.

lvii

Date of Election.

- 1893, Nov. 14. Taylor, R. L., F.C.S., F.I.C. *Central High School for Boys, Manchester, and 37, Mayfield Road, Whalley Range, Manchester.*
- 1911, Oct. 17. Thoday, D., M.A., Lecturer in Plant Physiology in the University of Manchester. *The University, Manchester.*
- 1911, Jan. 10. Thomson, J. Stuart, Ph.D. (Bern), F.R.S.E., F.L.S., Senior Demonstrator in Zoology in the Victoria University of Manchester. *The University, Manchester.*
- 1873, April 15. Thomson, William, F.R.S.E., F.I.C., F.C.S. *Royal Institution, Manchester.*
- 1896, Jan. 21. Thorburn, William, M.D., B.Sc. 2, *St. Peter's Square, Manchester.*
- 1899, Oct. 17. Todd, William Henry. *Rivington, Irlam Road, Flixton, near Manchester.*
- 1909, Jan. 26. Varley, George Percy, M.Sc. (Vic.), Central High School for Boys, Manchester. 19, *Mayfield Road, Whalley Range, Manchester.*
- 1912, Oct. 15. Walker, Miles, M.A., M.I.E.E., Professor of Electrical Engineering, the Municipal School of Technology, Manchester. *The Cottage, Leicester Road, Hale, Altrincham.*
- 1873, Nov. 18. Waters, Arthur William, F.L.S., F.G.S. *Alderley, McKinley Road, Bournemouth.*
- 1906, Nov. 13. Watson, D. M. S., M.Sc. 60, *Lissenden Mansions, Highgate Road, London, N.W.*
- 1892, Nov. 15. Weiss, F. Ernest, D.Sc., F.L.S., Acting Vice-Chancellor and Professor of Botany in the Victoria University of Manchester. *Easedale, Disley, Cheshire.*
- 1909, Feb. 9. Weizmann, Charles, Ph.D., D.Sc., Reader in Bio-Chemistry in the Victoria University of Manchester. *The University, Manchester.*
- 1908, May 12. Welldon, Rt. Rev. J. E. C., D.D., Dean of Manchester. *The Deanery, Manchester.*
- 1911, Oct. 17. West, Tom, B.Sc., Chemist and Metallurgist. 101, *Spring Bank Street, Stalybridge, near Manchester.*

Date of Election.

- 1901, Oct. 1. Wild, Robert B., M.D., M.Sc., F.R.C.P., Professor of Materia Medica and Therapeutics in the Victoria University of Manchester. 96, *Mosley Street, Manchester.*
- 1859, Jan. 25. Wilde, Henry, D.Sc., D.C.L., F.R.S. *The Hurst, Alderley Edge, Cheshire.*
- 1909, Jan. 26. Wolfenden, John Henry, B.Sc. (Lond.), A.R.C.S. (Lond.), Assistant Master in the Central High School for Boys, Whitworth Street, Manchester. 13, *Pole Lane, Failsworth.*
- 1905, Oct. 31. Woodall, Herbert J., A.R.C.S. 32, *Market Place, Stockport.*
- 1860, April 17. Woolley, George Stephen. *Victoria Bridge, Manchester.*
- 1895, Jan. 8. Worthington, Wm. Barton, B.Sc., M.Inst.C.E. *Kirkstyles, Duffield, near Derby.*

N.B.—Of the above list the following have compounded for their subscriptions, and are therefore life members:—

Bailey, Charles, M.Sc., F.L.S.

Ingleby, Joseph, M.I.Mech.E.

Worthington, Wm. Barton, B.Sc., M.Inst.C.E.

HONORARY MEMBERS.

Date of Election.

- 1892, April 26. Abney, Sir William de W., K.C.B., D.C.L., D.Sc., F.R.S.
*Rathmore Lodge, Bolton Gardens South, South Kensington,
London, S.W.*
- 1894, April 17. Appell, Paul, Membre de l'Institut, Professor of Theoretical
Mechanics. *Faculté des Sciences, Paris.*
- 1892, April 26. Baeyer, Adolf von, For. Mem. R.S., Professor of Chemistry
in the University of Munich. 1, *Arcisstrasse, Munich.*
- 1886, Feb. 9. Baker, John Gilbert, F.R.S., F.L.S. 3, *Cumberland
Road, Kew.*
- 1889, April 30. Carruthers, William, F.R.S., F.L.S. 44, *Central Hill,
Norwood, London, S.E.*
- 1903, April 28. Clarke, Frank Wigglesworth, D.Sc. *United States
Geological Survey, Washington, D.C., U.S.A.*
- 1866, Oct. 30. Clifton, Robert Bellamy, M.A., F.R.S., F.R.A.S., Pro-
fessor of Experimental Philosophy in the University of
Oxford. 3, *Baráweil Road, Banbury Road, Oxford.*
- 1892, April 26. Curtius, Theodor, Professor of Chemistry in the University
of Kiel. *Universität, Kiel.*
- 1892, April 26. Darboux, J. Gaston, Membre de l'Institut, Secrétaire per-
pétuel de l'Académie des Sciences, Doyen honoraire de
la Faculté des Sciences. 3, *Rue Mazarine, Paris.*
- 1894, April 17. Debus, H., Ph.D., F.R.S. 4, *Schlangenweg, Cassel
Hessen, Germany.*
- 1900, April 24. Dewar, Sir James, M.A., LL.D., D.Sc., F.R.S., V.P.C.S.,
Fullerian Professor of Chemistry at the Royal Institution.
Royal Institution, Albemarle Street, London, W.

Date of Election.

- 1892, April 26. Edison, Thomas Alva. *Orange, N.J., U.S.A.*
- 1895, April 30. Elster, Julius, Ph.D. 6, *Lessingstrasse, Wolfenbüttel.*
- 1900, April 24. Ewing, Sir J. Alfred, K.C.B., M.A., LL.D., F.R.S.,
Director of Naval Education to the Admiralty. *Frog-
hole, Edenbridge, Kent.*
- 1889, April 30. Farlow, W. G., Professor of Botany at Harvard College.
Harvard College, Cambridge, Mass., U.S.A.
- 1900, April 24. Forsyth, Andrew Russell, M.A., Sc.D., LL.D., F.R.S.
Professor of Mathematics at the Imperial College of
Science and Technology. *The Imperial College of
Science and Technology, S. Kensington, London.*
- 1892, April 26. Fürbringer, Max, Professor of Anatomy in the University
of Heidelberg. *Universität, Heidelberg.*
- 1895, April 30. Geitel, Hans. 6, *Lessingstrasse, Wolfenbüttel.*
- 1894, April 17. Glaisher, J. W. L., Sc.D., F.R.S. *Trinity College,
Cambridge.*
- 1894, April 17. Gouy, A., Corr. Memb. Inst. Fr. (Acad. Sci.), Professor
of Physics in the University of Lyons. *Faculté des
Sciences, Lyons.*
- 1900, April 24. Haeckel, Ernst, Ph.D., Professor of Zoology in the Uni-
versity of Jena. *Zoologisches Institut, Jena.*
- 1894, April 17. Harcourt, A. G. Vernon, M.A., D.C.L., F.R.S., V.P.C.S.
St. Clare, Ryde, Isle of Wight.
- 1894, April 17. Heaviside, Oliver, Ph.D., F.R.S. *Homefield, Lower War-
berry, Torquay.*
- 1892, April 26. Hill, G. W. *West Nyack, N. Y., U.S.A.*
- 1888, April 17. Hittorf, Johann Wilhelm, Professor of Physics at Münster,
Polytechnicum, Münster.
- 1892, April 26. Klein, Felix, Ph.D., For. Mem. R.S., Corr. Memb. Inst.
Fr. (Acad. Sci.), Professor of Mathematics in the
University of Göttingen. 3, *Wilhelm Weber Strasse,
Göttingen.*

Honorary Members.

lxi

Date of Election.

- 1894, April 17. Königsberger, Leo, Professor of Mathematics in the University of Heidelberg. *Universität, Heidelberg.*
- 1902, May 13. Larmor, Sir Joseph, M.A., D.Sc., LL.D., F.R.S., F.R.A.S. *St. John's College, Cambridge.*
- 1892, April 26. Liebermann, C., Professor of Chemistry in the University of Berlin. *29, Matthäi-Kirch Strasse, Berlin.*
- 1887, April 19. Lockyer, Sir J. Norman, K.C.B., LL.D., Sc.D., F.R.S., Corr. Memb. Inst. Fr. (Acad. Sci.). *Hill Observatory, Salcombe Regis, Sidmouth, Devon.*
- 1902, May 13. Lodge, Sir Oliver Joseph, D.Sc., LL.D., F.R.S., Principal of the University of Birmingham. *The University, Birmingham.*
- 1900, April 24. Lorentz, Henrik Anton, For. Mem. R.S., Corr. Memb. Inst. Fr. (Acad. Sci.), Professor of Physics in the University of Haarlem. *Zijweg, 76, Haarlem.*
- 1892, April 26. Marshall, Alfred, M.A., formerly Professor of Political Economy in the University of Cambridge. *Balliol Croft, Madingley Road, Cambridge.*
- 1901, April 23. Metschnikoff, Élie, D.Sc., For. Mem. R.S. *Institut Pasteur, Paris.*
- 1895, April 30. Mittag-Leffler, Gösta, D.C.L. (Oxon.), For. Mem. R.S., Professor of Mathematics in the University of Stockholm. *Djursholm, Stockholm.*
- 1910, April 5. Nernst, Geh. Prof. Dr. Walter, Director of the Physikal-Chemisches Institut in the University of Berlin. *Am Karlsbad 26a, Berlin W. 35.*
- 1902, May 13. Osborn, Henry Fairfield, Professor of Vertebrate Palæontology at Columbia College. *American Museum of Natural History, W. 77 Street, New York, U.S.A.*
- 1894, April 17. Ostwald, W., Professor of Chemistry. *Groszbothen, Kgr. Sachsen.*

Date of Election.

- 1899, April 25. Palgrave, Sir Robert H. Inglis, F.R.S., F.S.S. *Henstead Hall, Wrentham, Suffolk.*
- 1894, April 17. Pfeffer, Wilhelm, For. Mem. R.S., Professor of Botany in the University of Leipsic. *Botanisches Institut, Leipsic.*
- 1892, April 26. Quincke, G. H., For. Mem. R.S., Professor of Physics in the University of Heidelberg. *Universität, Heidelberg.*
- 1899, April 25. Ramsay, Sir William, K.C.B., Ph.D., Sc.D., M.D., F.R.S., Professor of Chemistry in University College, London. 19, *Chester Terrace, Regent's Park, London, N.W.*
- 1886, Feb. 9. Rayleigh, Right Hon. John William Strutt, Lord, O.M., M.A., D.C.L. (Oxon.), Sc.D. (Cantab.), LL.D. (Univ. McGill), F.R.S., F.R.A.S., Corr. Memb. Inst. Fr. (Acad. Sci.), Chancellor of the University of Cambridge. *Terling Place, Witham, Essex.*
- 1900, April 24. Ridgway, Robert, Curator of the Department of Birds, U.S. National Museum. *Brookland, District of Columbia, U.S.A.*
- 1897, April 27. Roscoe, Right Hon. Sir Henry Enfield, B.A., D.C.L. LL.D., F.R.S., V.P.C.S., Corr. Memb. Inst. Fr. (Acad. Sci.). *West-Horsley, Leatherhead, Surrey.*
- 1902, May 13. Scott, Dukinfield Henry, M.A., LL.D., Ph.D., F.R.S., F.L.S. *East Oakley House, Oakley, Hants.*
- 1892, April 26. Solms, H., Graf zu, Professor of Botany in the University of Strassburg. *Universität, Strassburg.*
- 1892, April 26. Thiselton-Dyer, Sir William T., K.C.M.G., C.I.E., M.A., Sc.D., Ph.D., LL.D., F.R.S. Lately Director Royal Botanic Gardens, Kew. *The Ferns, Witcombe, Gloucester.*
- 1895, April 30. Thomson, Sir Joseph John, O.M., M.A., Sc.D., F.R.S., Cavendish Professor of Experimental Physics in the University of Cambridge. *Trinity College, Cambridge.*

Date of Election.

- 1894, April 17. Thorpe, Sir T. Edward, C.B., Ph.D., D.Sc., LL.D.,
F.R.S., V.P.C.S. *Whinfield, Salcombe, S. Devon.*
- 1894, April 17. Turner, Sir William, K.C.B., M.B., D.C.L., LL.D.,
Sc.D., F.R.S., F.R.S.E., Professor of Anatomy in the
University of Edinburgh. *6, Elton Terrace, Edinburgh.*
- 1886, Feb. 9. Tylor, Sir Edward Burnett, D.C.L. (Oxon), LL.D. (St.
And. and McGill Univs.), F.R.S., formerly Professor of
Anthropology in the University of Oxford. *Linden,
Wellington, Somerset.*
- 1894, April 17. Vines, Sidney Howard, M.A., D.Sc., F.R.S., F.L.S.,
Sherardian Professor of Botany in the University of
Oxford. *Headington Hill, Oxford.*
- 1894, April 17. Warburg, Emil, Professor of Physics at the Physical
Institute, Berlin. *Physikalisches Institut, Neue Wilhelm-
strasse, Berlin.*

CHANGES OF ADDRESS.

*Members are particularly requested to inform the Secretaries
of any errors in their addresses or descriptions.*

Awards of the Dalton Medal.

1898. EDWARD SCHUNCK, Ph.D., F.R.S.
1900. Sir HENRY E. ROSCOE, F.R.S.
1903. Prof. OSBORNE REYNOLDS, LL.D., F.R.S.

THE WILDE LECTURES.

1897. (July 2) "On the Nature of the Röntgen Rays."
By Sir G. G. STOKES, Bart., F.R.S. (28 pp.)
1898. (Mar. 29.) "On the Physical Basis of Psychological Events." By Sir MICHAEL FOSTER, K.C.B., F.R.S. (46 pp.)
1899. (Mar. 28.) "The newly discovered Elements; and their relation to the Kinetic Theory of Gases." By Prof. WILLIAM RAMSAY, F.R.S. (19 pp.)
1900. (Feb. 13.) "The Mechanical Principles of Flight." By the Rt. Hon. LORD RAYLEIGH, F.R.S. (26 pp.)
1901. (April 22.) "Sur la Flore du Corps Humain." By Dr. ÉLIE METSCHNIKOFF, For.Mem.R.S. (38 pp.)
1902. (Feb. 25.) "On the Evolution of the Mental Faculties in relation to some Fundamental Principles of Motion." By Dr. HENRY WILDE, F.R.S. (34 pp., 3 pls.)
1903. (May 19.) "The Atomic Theory." By Professor F. W. CLARKE, D.Sc. (32 pp.)
1904. (Feb. 23.) "The Evolution of Matter as revealed by the Radio-active Elements." By FREDERICK SODDY, M.A. (42 pp.)

1905. (Feb. 28.) "The Early History of Seed-bearing Plants, as recorded in the Carboniferous Flora." By Dr. D. H. SCOTT, F.R.S. (32 pp., 3 pls.)
1906. (March 20.) "Total Solar Eclipses." By Professor H. H. TURNER, D.Sc., F.R.S. (32 pp.)
1907. (February 18.) "The Structure of Metals." By Dr. J. A. EWING, F.R.S., M.Inst.C.E. (20 pp., 5 pls., and 5 text-figs.)
1908. (March 3.) "On the Physical Aspect of the Atomic Theory." By Professor J. LARMOR, Sec. R.S. (54 pp.)
1909. (March 9.) "On the Influence of Moisture on Chemical Change in Gases." By Dr. H. BRERETON BAKER, F.R.S. (8 pp.)
1910. (March 22.) "Recent Contributions to Theories regarding the Internal Structure of the Earth." By Sir THOMAS H. HOLLAND, K.C.I.E., D.Sc., F.R.S.
-

SPECIAL LECTURES.

1913. (March 4.) "The Plant and the Soil." By A. D. HALL, M.A., F.R.S.
1914. (March 18.) "Crystalline Structure as revealed by X-rays." By Professor W. H. BRAGG, M.A., F.R.S.
1915. (May 4th.) "The Place of Science in History." By Professor JULIUS MAC LEOD, D.Sc.

*LIST OF PRESIDENTS OF THE SOCIETY.**Date of Election.*

1781. PETER MAINWARING, M.D., JAMES MASSEY.
 1782-1786. JAMES MASSEY, THOMAS PERCIVAL, M.D., F.R.S.
 1787-1789. JAMES MASSEY.
 1789-1804. THOMAS PERCIVAL, M.D., F.R.S.
 1805-1806. REV. GEORGE WALKER, F.R.S.
 1807-1809. THOMAS HENRY, F.R.S.
 1809. *JOHN HULL, M.D., F.L.S.
 1809-1816. THOMAS HENRY, F.R.S.
 1816-1844. JOHN DALTON, D.C.L., F.R.S.
 1844-1847. EDWARD HOLME, M.D., F.L.S.
 1848-1850. EATON HODGKINSON, F.R.S., F.G.S.
 1851-1854. JOHN MOORE, F.L.S.
 1855-1859. SIR WILLIAM FAIRBAIRN, Bart., LL.D., F.R.S.
 1860-1861. JAMES PRESCOTT JOULE, D.C.L., F.R.S.
 1862-1863. EDWARD WILLIAM BINNEY, F.R.S., F.G.S.
 1864-1865. ROBERT ANGUS SMITH, Ph.D., F.R.S.
 1866-1867. EDWARD SCHUNCK, Ph.D., F.R.S.
 1868-1869. JAMES PRESCOTT JOULE, D.C.L., F.R.S.
 1870-1871. EDWARD WILLIAM BINNEY, F.R.S., F.G.S.
 1872-1873. JAMES PRESCOTT JOULE, D.C.L., F.R.S.
 1874-1875. EDWARD SCHUNCK, Ph.D., F.R.S.
 1876-1877. EDWARD WILLIAM BINNEY, F.R.S., F.G.S.
 1878-1879. JAMES PRESCOTT JOULE, D.C.L., F.R.S.
 1880-1881. EDWARD WILLIAM BINNEY, F.R.S., F.G.S.
 1882-1883. SIR HENRY ENFIELD ROSCOE, D.C.L., F.R.S.
 1884-1885. WILLIAM CRAWFORD WILLIAMSON, LL.D., F.R.S.
 1886. ROBERT DUKINFIELD DARBISHIRE, B.A., F.G.S.
 1887. BALFOUR STEWART, LL.D., F.R.S.

* Elected April 28th; resigned office May 5th.

List of Presidents of the Society.

lxvii

Date of Election.

- 1888-1889. OSBORNE REYNOLDS, LL.D., F.R.S.
1890-1891. EDWARD SCHUNCK, Ph.D., F.R.S.
1892-1893. ARTHUR SCHUSTER, Ph.D., F.R.S.
1894-1896. HENRY WILDE, D.C.L., F.R.S.
1896. EDWARD SCHUNCK, Ph.D., F.R.S.
1897-1899. JAMES COSMO MELVILL, M.A., F.L.S.
1899-1901. HORACE LAMB, M.A., F.R.S.
1901-1903. CHARLES BAILEY, M.Sc., F.L.S.
1903-1905. W. BOYD DAWKINS, M.A., D.Sc., F.R.S.
1905-1907. Sir WILLIAM H. BAILEY, M.I.Mech.E.
1907-1909. HAROLD BAILY DIXON, M.A., F.R.S.
1909-1911. FRANCIS JONES, M.Sc., F.R.S.E.
1911-1913. F. E. WEISS, D.Sc., F.L.S.
1913-1915. FRANCIS NICHOLSON, F.Z.S.
1915- SYDNEY J. HICKSON, M.A., D.Sc., F.R.S.
-

1871

1872

1873

1874







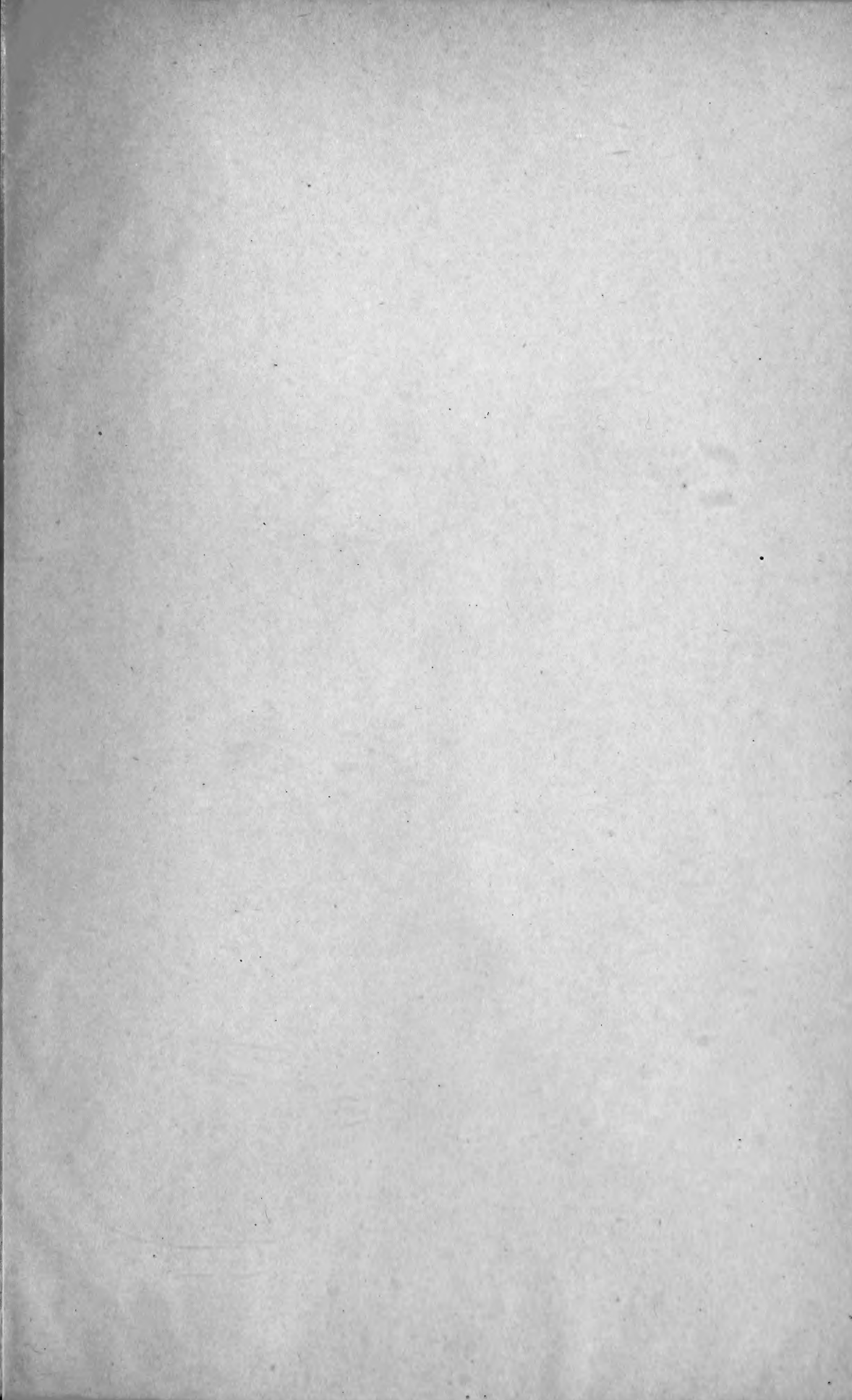



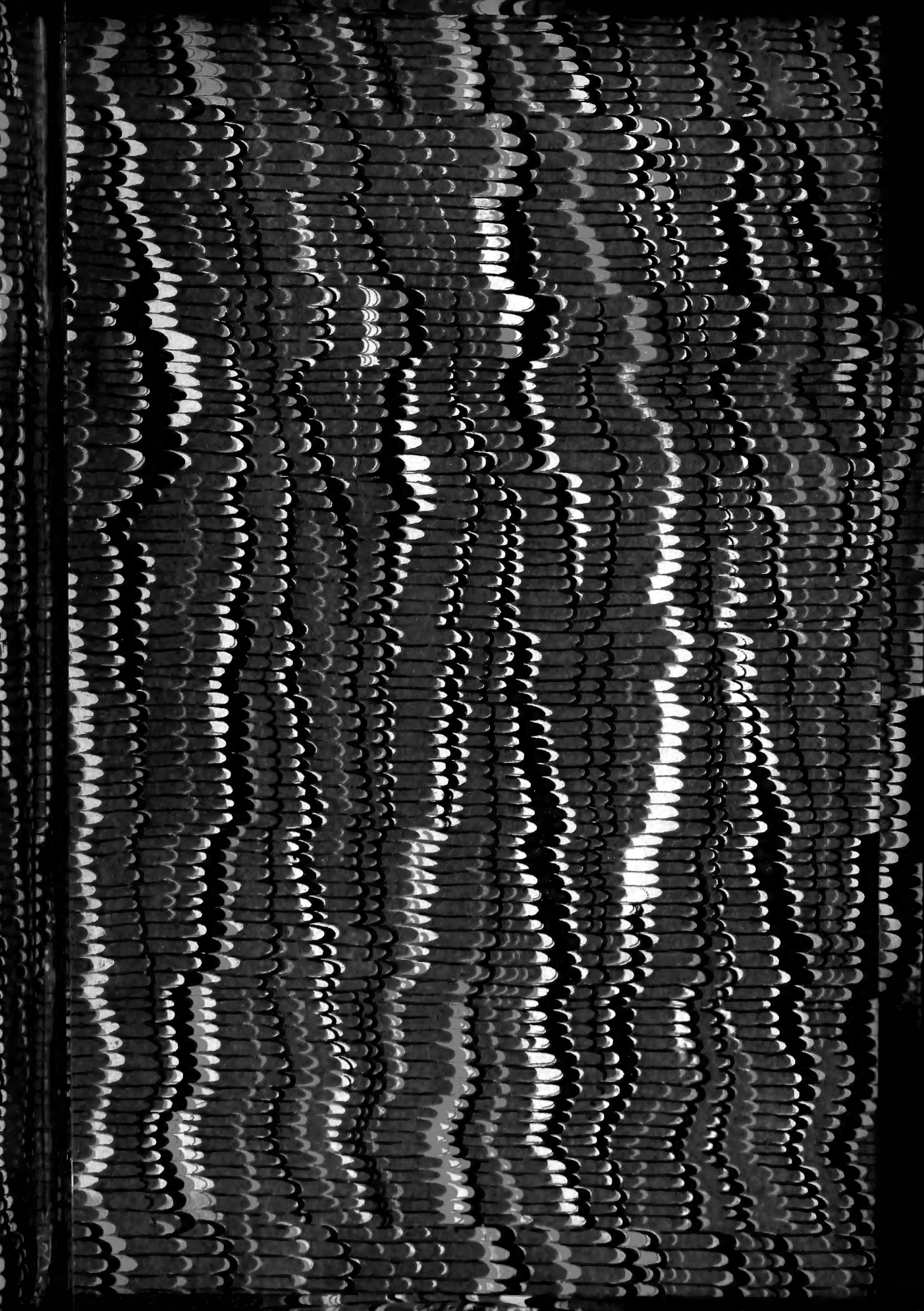

SMITHSONIAN INSTITUTION LIBRARIES



3 9088 01303 6017