

MEMOIRS AND PROCEEDINGS  
OF  
THE MANCHESTER  
LITERARY & PHILOSOPHICAL SOCIETY.





506.42  
M26

MEMOIRS AND PROCEEDINGS  
OF  
THE MANCHESTER  
LITERARY & PHILOSOPHICAL  
SOCIETY

*FOURTH SERIES*

EIGHTH VOLUME

MANCHESTER  
36 GEORGE STREET

—  
1894

96

NOTE.

---

The authors of the several papers contained in this volume are themselves accountable for all the statements and reasonings which they have offered. In these particulars the Society must not be considered as in any way responsible.

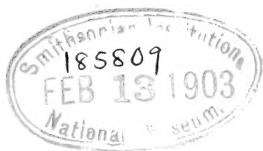

## CONTENTS.

| MEMOIRS.                                                                                                                                                                                                                                                                                                            | PAGE |
|---------------------------------------------------------------------------------------------------------------------------------------------------------------------------------------------------------------------------------------------------------------------------------------------------------------------|------|
| Experiments on the Relation between Uniform Stress and Permanent Strain in Wrought-iron and Steel. By T. E. STANTON, B.Sc., Demonstrator in the Whitworth Engineering Laboratory, Owens College, Manchester. Communicated by Professor OSBORNE REYNOLDS, F.R.S. ... ..                                              | 2    |
| Some Aspects of Town Air as contrasted with that of the Country. By G. H. BAILEY, D.Sc., Ph.D. ... ..                                                                                                                                                                                                               | 11   |
| On a New Sporiferous Spike from the Lancashire Coal Measures. By THOMAS HICK, B.A., B.Sc., Assistant Lecturer in Botany, Owens College, Manchester, and JAMES LOMAX ... ..                                                                                                                                          | 22   |
| Preliminary Experiments on the Latent Heat of Steam at 100°C. By P. J. HARTOG, B.Sc. (Lond. and Vict.), Assistant Lecturer and late Berkeley Fellow in the Owens College, and J. A. HARKER, D.Sc. (Tübingen), Berkeley Fellow in the Owens College. Communicated by Professor ARTHUR SCHUSTER, Ph.D., F.R.S. ... .. | 37   |
| General, Morphological, and Histological Index to the Author's Collective Memoirs on the Fossil Plants of the Coal Measures. Part III. By WILLIAM CRAWFORD WILLIAMSON, LL.D., F.R.S., &c., Foreign Member of the Royal Swedish Academy; Corresponding Member of the Royal Society of Göttingen .. ..                | 54   |
| Notes on <i>Wulfenia Carinthiaca</i> , Jacquin. By JAMES COSMO MELVILL, M.A., F.L.S. ... ..                                                                                                                                                                                                                         | 75   |
| On the K-partitions of the R-gon. By the Rev. THOS. P. KIRKMAN, M.A., F.R.S. ... ..                                                                                                                                                                                                                                 | 109  |
| On the Osmotic Pressure of Solutions of Finite Concentration. By THOMAS EWAN, B.Sc., Ph.D.... ..                                                                                                                                                                                                                    | 130  |
| On the Treatment of Sewage with Basic Per-Salts of Iron under varying conditions. By HARRY GRIMSHAW, F.C.S. ... ..                                                                                                                                                                                                  | 143  |
| An Analysis of the Electro-Motive Force and Current Curves of a Wilde Alternator, under various conditions. By JULIUS FRITH, Heginbottom Physical Scholar of the Owens College. Communicated by ARTHUR SCHUSTER, Ph.D., F.R.S. ... ..                                                                               | 151  |



|                                                                                                                                                                    | PAGE                    |
|--------------------------------------------------------------------------------------------------------------------------------------------------------------------|-------------------------|
| HYDE, HENRY.—On the Growth of Maize near Manchester ... ..                                                                                                         | 19                      |
| JONES, FRANCIS, F.R.S.Ed.—On Specimens of Marble exposed to town air ... ..                                                                                        | 30                      |
| LAMB, HORACE, M.A., F.R.S.—On the mode of Propagation of Waves through Water by a Moving Object ... ..                                                             | 34                      |
| LANGDON, M. J., Ph.D.—On Specimens of the Salt of Technical Chlorophyll ... ..                                                                                     | 20                      |
| LEES, C. H.—On the determination of the Thermal Conductivity of Water ... ..                                                                                       | 34                      |
| MELVILL, J. COSMO, M.A., F.L.S.—On <i>Bulimus labeo</i> and various New Zealand Insects ... ..                                                                     | 83                      |
| NICHOLSON FRANCIS, F.Z.S.—On Gulls at Old Trafford ... ..                                                                                                          | 86                      |
| REYNOLDS, OSBORNE, LL.D., M.A., F.R.S., M.I.C.E.—On the Latent Heat of Steam ... ..                                                                                | 31                      |
| On Kitchen Boiler Explosions ... ..                                                                                                                                | 90                      |
| On an Aurora seen at Fallowfield ... ..                                                                                                                            | 107                     |
| SMITHELLS, Prof.—On Flame and Flame Spectra ... ..                                                                                                                 | 98                      |
| SCHUSTER, ARTHUR, Ph.D., F.R.S., F.R.A.S.—On an Oak Tree struck by Lightning .. ..                                                                                 | 91                      |
| On Apparatus for testing Clinical Thermometers ... ..                                                                                                              | 100                     |
| WEISS, Prof. F. E.—On Second Crops of Fruit on Raspberry Canes, on Second Flowers on Apple Trees, and on a Monstrous Wallflower... ..                              | 20                      |
| On Pieces of Wood found in Gravel Beds near Stockport ... ..                                                                                                       | 35                      |
| WELLS, LIONEL B., M.I.C.E.—On the Inland Waterways of England and Wales .. ..                                                                                      | 32                      |
| WILDE, HENRY, F.R.S.—On the Philosophical Uses to which the Corporation Supply of Electricity may be put ... ..                                                    | 93                      |
| General Meetings ... ..                                                                                                                                            | 30, 90, 98, 105         |
| Annual General Meeting ... ..                                                                                                                                      | 171                     |
| Report of the Council with Obituary Notices of Archibald Sandeman, John Tyndall, Heinrich Hertz, Arthur Milnes Marshall, Charles Clay, and Thomas Armstrong ... .. | 205                     |
| Treasurer's Accounts ... ..                                                                                                                                        | 220                     |
| Meetings of the Natural History and Microscopical Section: Annual ... ..                                                                                           | 173                     |
| Ordinary ... ..                                                                                                                                                    | 19, 21, 83, 92, 99, 106 |
| Annual Report of the Microscopical and Natural History Section— ... ..                                                                                             | 223                     |
| List of the Council and Members ... ..                                                                                                                             | 226                     |

## PLATES, &amp;c.

|                                                                                                      | TO FACE PAGE |
|------------------------------------------------------------------------------------------------------|--------------|
| I.—To illustrate Mr. Melvill's paper on <i>Wulfenia Carinthiaca</i> ...                              | 82           |
| II.—To illustrate Mr. Kirkman's paper on the K-partitions of the R-gon                               | 109          |
| III, IV, V, VI, VII, VIII.—To illustrate Mr. Frith's paper on the Wilde<br>Alternator ... ..         | 151          |
| IX.—To illustrate Mr. Hick's paper on the Stem of Calamites ...                                      | 170          |
| X.—To illustrate Mr. Wilde's paper on the influence of Coast-lines on<br>Magnetic Declination ... .. | 186          |
| XI.—To illustrate Mr. Wells's paper on Canal and River Navigation ...                                | 204          |

## CORRECTIONS.

On p. 40, line 11, the equation should be as follows:—

$$L = \frac{w \int_{t_0}^{t_f} c dt}{W} - \int_{t_f}^T C dt$$

Page 98. Mr. ROBERT MOND's election recorded in ordinary Meeting, took place at a duly summoned *General Meeting* on the same evening.

MEMOIRS AND PROCEEDINGS  
OF  
THE MANCHESTER LITERARY AND  
PHILOSOPHICAL SOCIETY.

---

Ordinary Meeting, October 3rd, 1893.

Professor OSBORNE REYNOLDS, M.A., LL.D., F.R.S.,  
Vice-President, in the Chair.

The thanks of the members were voted to the donors of the books upon the table.

Mr. T. E. STANTON, B.Sc., read a paper on "Experiments on the relation between Permanent Strain and Uniform Stress in Wrought Irons."

Dr. G. H. BAILEY read a paper entitled "Some Aspects of Town Air as contrasted with that of the Country," in which he dwelt on the importance of quantitative investigations as to the impurities other than carbonic acid present in air as a measure of pollution, and urged that, however minute the quantities may be, they are sufficient to bring about serious disorganization in plant life and in human beings. In illustration Dr. Bailey presented tables showing considerable variations in the quantity of sulphur compounds present in different localities in Manchester and London on clear days and on slightly or densely foggy days. Some surprise was caused by a table showing that during the dense fogs of December last in Manchester and London there was a much larger proportion of sulphur compounds present in the London than in the Manchester air, notwithstanding the fact that the coal consumed in Manchester is generally understood to be much more sulphurous than that burnt in London. Professor WEISS confirmed the statement made by Dr. BAILEY.

---

**Experiments on the Relation between Uniform Stress and Permanent Strain in Wrought-iron and Steel.**  
By T. E. Stanton, B.Sc., Demonstrator in the Whitworth Engineering Laboratory, Owens College, Manchester. Communicated by Professor Osborne Reynolds, F.R.S.

*(Received October 21st, 1893.)*

When an iron bar is subjected to uniform longitudinal stress exceeding its elastic limit, the connection between the stress and the permanent set of the material is usually shown by means of a Stress-Strain diagram, in which the stresses are represented by the ordinates, and the corresponding elongations by the abscissae of the curve. These can be traced by an autographic apparatus attached to the machine, several types of which are in use.

The objection to this method is, that the position of the curve, and also its form, are greatly influenced by the rate at which the load on the bar is increased. Prof. Ewing\* has also shown that the effect of a pause in the loading has a hardening effect on the bar, which increases with the length of the time during which the load is kept constant. On increasing the load after this interval, it is found that permanent set does not again take place until a considerable increase in the load has been made. This has been called the "hardening effect of the time."

An illustration of this is shown in *Fig. 1*, which is the Stress-Strain diagram for a wrought-iron bar tested in the following manner:—

The bar was turned accurately parallel and fixed in the Testing Machine and a stress of 16 tons per square inch of



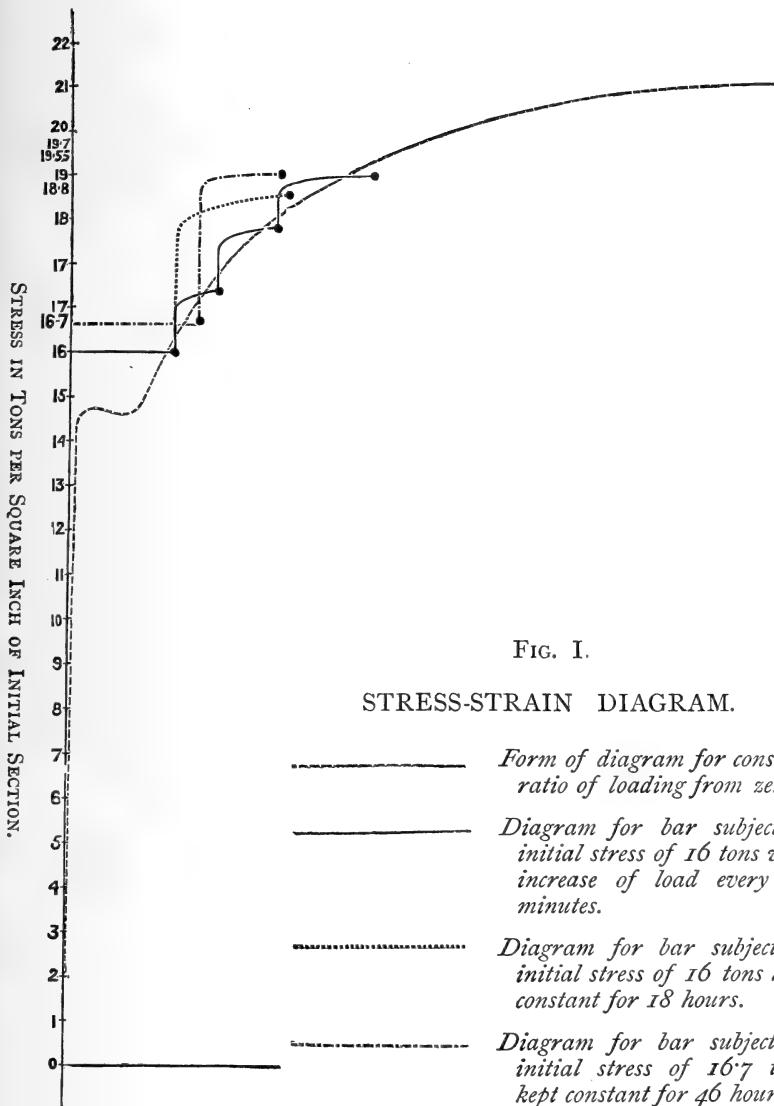

FIG. I.

STRESS-STRAIN DIAGRAM.

- Form of diagram for constant ratio of loading from zero.
- Diagram for bar subject to initial stress of 16 tons with increase of load every 20 minutes.
- ..... Diagram for bar subject to initial stress of 16 tons kept constant for 18 hours.
- . - . - Diagram for bar subject to initial stress of 16.7 tons kept constant for 46 hours.

PERMANENT SET IN A LENGTH OF 10 INCHES.

initial section applied, and kept constant for 20 minutes. The extension of the bar practically ceased after 15 minutes. On increasing the load it was found that no further permanent set took place until the stress had reached 17·0 tons per square inch, at which point the bar commenced to draw out rapidly. At 17·40 tons another pause of 20 minutes was made, and the test continued as before. It is seen that the hardening effect of each load extends through practically the same range of stress.

In the same figure the dotted curve is the diagram for a bar of the same length and sectional area as the first, but loaded in a different manner. The same initial stress of 16 tons per square inch was applied, producing the same permanent strain as before. The load was then kept constant for 18 hours. On increasing the load no permanent set took place until the stress had reached 18·8 tons per square inch. After this the drawing out took place rapidly. In this case, the hardening effect extended through an increase of stress of 2·5 tons. A similar test was made on a bar of the same material, the initial stress of 16·7 tons being kept constant for 46 hours. In this case the hardening effect extended through an increase of stress of 3·0 tons.

It is seen from the diagrams that when permanent set again takes place, after the load being kept constant, that the amount of extension depends on the time during which the preceding stress has been kept constant.

Thus, in the tests of bars A and C, which were of the same material and initial dimensions, the extension of A for a stress of 20 tons was 1·125" in a length of 10". The extension of C for the same stress, after having been subject to a stress of 16·7 tons for 46 hours was ·762", or 32% less than that of A.

In order to establish a relation between the stress and permanent strain by experiment it was necessary that the elongation caused by any given stress should not be affected

by the time duration of previous stress. For this purpose a bar of wrought-iron of very soft quality was cut up into nine lengths of 20 inches, and the 20" bars turned parallel.

Each bar was placed in the testing machine and a given stress applied, the full stress being attained in about one minute. The load was kept constant for thirty minutes, when the permanent strain was observed and the bar taken out of the machine. The results of these experiments when combined show that the relation between the stress and permanent strain is given by the formula

$$p = Ce^k,$$

where  $p$  = stress in tons per square inch on the reduced section of the bar.

$$e = \text{permanent strain} = \frac{l' - l}{l},$$

where  $l$  = initial length,  $l'$  = stretched length,  $C$  = constant.

This relation is clearly seen in *Fig. 2*, in which Professor Reynolds'\* method of logarithmic plotting is used. Thus, if points whose ordinates and abscissae are respectively the logarithms of  $p$  and  $e$  are plotted; these points are found to lie on a straight line, the inclination of which will give the value of  $k$ , which in the above experiments was found to be .25.

Assuming the above formula, then in the case of the nine bars, the maximum variation in the value of the constant  $C$  is from 39.25 to 39.49, or 0.6%.

It seemed probable that the permanent strains produced in testing a single bar by successive loads would not be given by the above formula; but in *Fig. 2*, where the results for bars No. 2 and 7 are plotted, it is seen that the same relation holds approximately for cases where the time duration of the stress does not exceed 30 minutes.

In the case of bar No. 13, where the second stress

FIG. II.

LOGARITHMIC CURVES OF STRESS AND STRAIN.

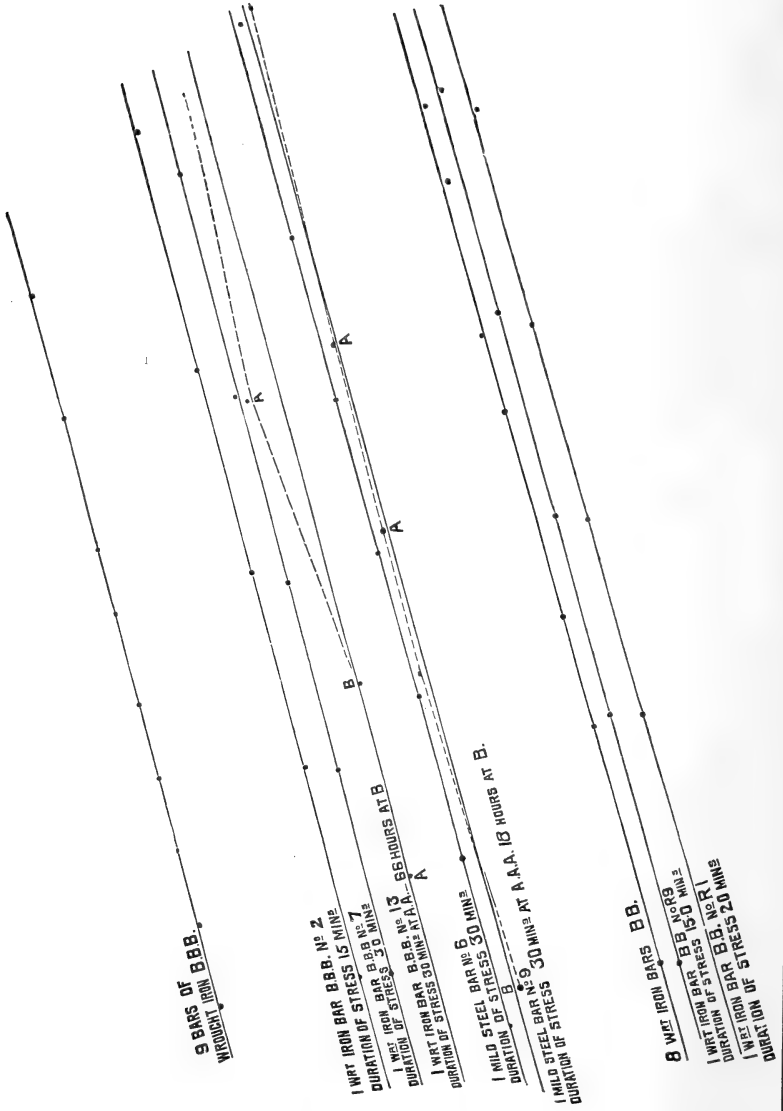

LOGARITHMS OF STRESSES.

LOGARITHMS OF PERMANENT STRAIN.

applied was kept constant for 66 hours, the hardening has a marked effect on the next permanent sets, which were each 20% less than that due to the loads.

The above tests were all made on the same brand of B.B.B. iron, the only variation being in the value of the constant  $C$ . which, for bar No. 2, was 40.30, and for bar No. 7 was 40.35.

Experiments were also made on some bars of mild steel, the results for which are shown in *Fig. 2*. In these, with a time duration of stress not exceeding 30 minutes, the value of  $k$  was found to be  $\frac{1}{4}$ . The results are also plotted for the case of a mild steel bar, in which the initial stress was kept constant for 18 hours.

Similar experiments made on nine specimens, cut from a long bar of Crown BB iron, did not give such consistent results. This was probably due to the varying hardness of the material in different portions of the bar.

In the case of bars R1 and R9 taken from these, and tested with successive loads at intervals of 20 and 15 minutes respectively, the value of  $k$  was found to be .275 for R1, and .265 for R9. The combined results for the other seven bars, each tested with one load only, gave .265 as the value of  $k$ .

Several other experiments were made on iron of different qualities, including some on Low Moor iron. The results showed that in the case of iron of a soft and fibrous nature, the same law of permanent set held, but when the iron was harder and showed a crystalline fracture the relation could not be expressed in the above form.

If  $p_0$  = stress on initial section of bar, then, assuming the density to remain constant and taking the formula

$$p = Ce^{\frac{1}{4}e} \quad (1)$$

we have

$$p_0 = \frac{Ce^{\frac{1}{4}e}}{1+e} \quad (2)$$

the condition for a maximum value of  $p_0$  being when

$$e = \frac{1}{3}.$$

Substituting this value for  $e$  in equation (2) we have, taking  $C = 39.4$ ,

$$p_0 = 22.45 \text{ tons per square inch.}$$

This corresponds very closely with the mean maximum stress of wrought-iron of this brand, experiments on rough bars giving values of  $p_0$  ranging from 21.8 to 20.70 tons.

TABLE I.

*Tests of nine specimens cut from a bar of wrought-iron. Brand R.H., Crown B.B.B.*

| No. of Specm. | Initial Area. sq. in. | Final Area. sq. in. | Permanent Strain. | Stress on Reduced Section. Tons. | Value of C. |
|---------------|-----------------------|---------------------|-------------------|----------------------------------|-------------|
| Z. 1.         | .7643                 | .7420               | .03071            | 16.480                           | 39.37       |
| Z. 2.         | .7590                 | .7238               | .05227            | 18.873                           | 39.48       |
| Z. 3.         | .7528                 | .6999               | .08133            | 20.977                           | 39.32       |
| Z. 4.         | .7648                 | .7378               | .03978            | 17.620                           | 39.46       |
| Z. 5.         | .7605                 | .7158               | .06585            | 19.973                           | 39.42       |
| Z. 6.         | .7810                 | .7638               | .02330            | 15.338                           | 39.27       |
| Z. 7.         | .7600                 | .7412               | .02689            | 15.893                           | 39.25       |
| Z. 8.         | .7510                 | .7178               | .04668            | 18.306                           | 39.38       |
| Z. 9.         | .7560                 | .7306               | .03490            | 17.068                           | 39.49       |

*Test of one specimen cut from a bar of wrought-iron. Brand R.H. Crown B.B.B. Duration of stress 15 minutes.*

| No. of Specm. | Initial Area. sq. in. | Final Area. sq. in. | Permanent Strain. | Stress on Reduced Section. Tons. | Value of C. |
|---------------|-----------------------|---------------------|-------------------|----------------------------------|-------------|
| 2.            | .7410                 | —                   | —                 | —                                | —           |
| —             | —                     | .7238               | .02450            | 15.888                           | 40.17       |
| —             | —                     | .7163               | .03547            | 17.451                           | 40.20       |
| —             | —                     | .7066               | .05005            | 19.106                           | 40.40       |
| —             | —                     | .6940               | .07159            | 20.893                           | 40.40       |
| —             | —                     | .6725               | .10875            | 23.050                           | 40.15       |

*Test of one specimen cut from a bar of wrought-iron. Brand R.H. Crown B.B.B. Duration of stress 30 minutes.*

| No. of Specm. | Initial Area.<br>sq. in. | Final Area.<br>sq. in. | Permanent Strain. | Stress on Reduced Section.<br>Tons. | Value of C. |
|---------------|--------------------------|------------------------|-------------------|-------------------------------------|-------------|
| 7.            | ·7776                    | —                      | —                 | —                                   | —           |
| —             | —                        | ·7646                  | ·01731            | 14·583                              | 40·20       |
| —             | —                        | ·7594                  | ·02462            | 16·000                              | 40·39       |
| —             | —                        | ·7527                  | ·03526            | 17·472                              | 40·31       |
| —             | —                        | ·7447                  | ·04914            | 19·000                              | 40·36       |
| —             | —                        | ·7306                  | ·06822            | 20·735                              | 40·57       |
| —             | —                        | ·7103                  | ·10096            | 22·740                              | 40·34       |

*Test of one specimen cut from a bar of mild steel. Duration of stress 30 minutes.*

| No. of Specm. | Initial Area.<br>sq. in. | Final Area.<br>sq. in. | Permanent Set. | Stress on Reduced Section.<br>Tons. | Value of C. |
|---------------|--------------------------|------------------------|----------------|-------------------------------------|-------------|
| 6.            | ·7689                    | —                      | —              | —                                   | —           |
| —             | ·7515                    | —                      | ·02233         | 19·294                              | 49·92       |
| —             | ·7458                    | —                      | ·03015         | 20·780                              | 49·88       |
| —             | ·7390                    | —                      | ·04003         | 22·330                              | 49·92       |
| —             | ·7302                    | —                      | ·05168         | 23·970                              | 50·27       |
| —             | ·7200                    | —                      | ·06752         | 25·694                              | 50·41       |
| —             | ·7050                    | —                      | ·09005         | 27·660                              | 50·49       |
| —             | ·6793                    | —                      | ·13140         | 30·178                              | 50·13       |

TABLE II.

*Tests of nine specimens cut from a bar of wrought-iron. Brand R.H. Crown B.B.*

Value of  $k = \cdot 265$ .

| No. of Specm. | Initial Area.<br>sq. in. | Final Area.<br>sq. in. | Permanent Strain. | Stress on Reduced Section.<br>Tons. | Value of C. |
|---------------|--------------------------|------------------------|-------------------|-------------------------------------|-------------|
| R. 5.         | ·7651                    | ·7475                  | ·0249             | 14·792                              | 39·358      |
| R. 2.         | ·7658                    | ·7412                  | ·0385             | 16·554                              | 39·242      |
| R. 7.         | ·7667                    | ·7344                  | ·0475             | 17·430                              | 39·090      |
| R. 3.         | ·7635                    | ·7185                  | ·0661             | 19·207                              | 39·455      |
| R. 6.         | ·7651                    | ·7151                  | ·0756             | 20·025                              | 39·700      |
| R. 8.         | ·7627                    | ·6991                  | ·0991             | 21·170                              | 39·063      |
| R. 4.         | ·7658                    | ·6940                  | ·1129             | 21·990                              | 39·200      |

10 *Uniform Stress and Permanent Strain.*

*Test of one specimen taken from the same bar as the above. Duration of stress 20 minutes.*

Value of  $k = \cdot 275$ .

| No. of Specm. | Initial Area.<br>sq. in. | Final Area.<br>sq. in. | Permanent Strain. | Stress on Reduced Section.<br>Tons. | Value of C. |
|---------------|--------------------------|------------------------|-------------------|-------------------------------------|-------------|
| R. 1.         | ·7667                    | —                      | —                 | —                                   | —           |
|               |                          | ·7390                  | ·03870            | 16·604                              | 40·606      |
|               |                          | ·7290                  | ·05460            | 18·230                              | 40·556      |
|               |                          | ·7155                  | ·07705            | 20·014                              | 40·502      |
|               |                          | ·6954                  | ·11250            | 21·944                              | 40·015      |

*Test of one specimen taken from the same bar as the above. Duration of stress 15 minutes.*

$k = \cdot 265$ .

| No. of Specm. | Initial Area.<br>sq. in. | Final Area.<br>sq. in. | Permanent Strain. | Stress on Reduced Section.<br>Tons. | Value of C. |
|---------------|--------------------------|------------------------|-------------------|-------------------------------------|-------------|
| R. 9.         | ·7651                    | —                      | —                 | —                                   | —           |
| —             | —                        | ·7475                  | ·0249             | 14·790                              | 39·352      |
| —             | —                        | ·7381                  | ·0387             | 16·624                              | 39·355      |
| —             | —                        | ·7283                  | ·0550             | 18·248                              | 39·357      |
| —             | —                        | ·7140                  | ·0787             | 20·056                              | 39·338      |
| —             | —                        | ·6925                  | ·1176             | 22·036                              | 38·858      |

These tests were all made in the 100-ton testing machine in the Whitworth Laboratory, Owens College.



**Some Aspects of Town Air as contrasted with that of the Country. By G. H. Bailey, D.Sc., Ph.D.**

*(Received October 31st, 1893.)*

The constituents of the air which are usually determined are the oxygen and the carbonic acid. The variations in the oxygen are small, and for the most part fall between 21 per cent by volume as a maximum and 20·9 as a minimum, though in special cases lower values (*e.g.* Angus Smith's determination of 20·26 in mines) have been recorded. The minimum for carbonic acid gas in country air may be taken at ·029 per cent rising in cloudy weather and at night time to ·033, though it frequently approaches ·04. For town air ·04 may be taken as a favourable record, while in foggy weather ·07 is the maximum (Angus Smith). It is thus seen that the variations in the amount of oxygen and of carbonic acid are comparatively small, and in the case of the latter even the record for highly polluted air is only about double that usually found in country air. Carbonic acid in the air of dwellings and public buildings increases to as much as tenfold its normal value, and in such cases a mere determination of this constituent of air is a sufficient indication of the nature of the air. Excepting the case of dwellings, carbonic acid gas does not afford a ready means of distinguishing between polluted and unpolluted air, or of comparing the air of one district of a city with that of another in regard to pollution.

Nor is it at all likely that air containing ·07 per cent of carbonic acid (but otherwise uncontaminated) is injurious to health. Angus Smith found no ill-effects from air containing 0·19 per cent of this gas, that is four times the amount occurring in polluted air of the streets. Though exhaustive enquiries have been made into the question of the distribution and amount of the carbonic acid gas in the

air, comparatively little has been done in the direction of such matters as hydrocarbons, sulphur compounds, and organic matter, &c., occurring in polluted air in larger quantities and in country air in traces.

This, no doubt, partly arises from the analytical difficulties presented by the problem, but chiefly, I think, from a want of appreciation of the importance of such determinations. For though it would be freely acknowledged that such bodies as sulphuretted hydrogen, sulphurous acid, pyridines, and the like, are, in a concentrated form, injurious to plant and animal life, it is usually taken for granted that a dilution to such an extent that we have to speak of parts per million, must rob these substances of any deleterious character which they possess in a concentrated form. It is the purpose of this paper—

(1) To suggest the determination of certain minor constituents of air as a means of discriminating between polluted and unpolluted air, and as a measure of pollution.

(2) To bring forward evidence that, minimal though the quantities may be, they are, notwithstanding, sufficient to bring about serious disorganisation in plant life and in human beings.

So far as our present knowledge goes, the more important of the minor constituents of town air, excluding carbonic acid gas and moisture, may be classified under the following heads :—

*Solid matter.*—Carbon, associated with which is a considerable quantity of sand and some iron and oxide (probably sulphide) of iron ; mineral salts, such as sulphate and carbonate of ammonia, common salt, and in manufacturing districts products ejected from works, especially alkalis, copper salts, and the like ; organised substances and micro-organisms.

*Liquid matters.*—These are hydrocarbons, pyridine, free sulphuric and sometimes nitric acid.

*Gaseous matters.*—Sulphurdioxide, hydrochloric acid, occasionally nitrous acid, sulphuretted hydrogen and allied bodies emanating from decaying refuse and from sewers, carbonic oxide, and gaseous hydrocarbons.

Of these impurities, there are many which are unsuited for the purpose of indicating pollution, in consequence of the difficulties attending their estimation, and there are others which have no particular significance. Those which can be readily determined are the soluble sulphur compounds, hydrochloric acid and chlorides, suspended organic matter, ammonia and its salts, micro-organisms, and methods appropriate for the estimation of these have already been described. The extent of the variations may be instanced by the following quotations, chiefly gathered from the results published by the Manchester Air Analysis Committee :—

*Sulphur compounds*—expressed in volumes of  $\text{SO}_2$  per million volumes of air.

(a) *At the Owens College.*

|                                                                                                     |                 |
|-----------------------------------------------------------------------------------------------------|-----------------|
| In clear breezy weather, the atmospheric con-<br>ditions being such that free diffusion takes place | } 0·1 to<br>0·5 |
| Dull hazy weather in the winter months ... ..                                                       | 2 to 5          |
| Slight fog .. .. .                                                                                  | 2 to 10         |
| Dense fog ... .. .                                                                                  | 10 to 20        |

(b) *In different localities, the time of observation being in each case the same.*

|                                                      |      |
|------------------------------------------------------|------|
| The Owens College... .. dense fog Dec. 21, 1892      | 12·7 |
| Hulme (Embden Street)... .. " " "                    | 16·2 |
| Town Hall ... .. " " "                               | 15·0 |
| Blackfriars Street ... .. " " "                      | 20·8 |
| Regent Road, Salford ... .. " " "                    | 24·8 |
| University College, London .. .. Dec. 22, 1892       | 30·1 |
| St. Bartholomew's Hos-<br>pital, London ... .. " " " | 38·1 |
| " " " .. .. Dec. 23, 1892                            | 18·9 |
| St. George's Hospital, London .. .. " " "            | 15·0 |
| University College, .. .. " " "                      | 10·0 |
| Hampstead .. .. " " "                                | 5·8  |

The maximum so far recorded for town air is 38·1, and the minimum 0·1—a sufficiently wide difference to serve as a means of indicating, in a very marked manner, the extent of pollution of air under varying atmospheric conditions, while within the same city there are also sufficiently wide differences. Common experience of the condition of the air in the respective localities, and under the conditions given, will lend support to such a differentiation as is shown in the numbers given.

Without going further into results which, however, can be seen by referring to the work of the Air Analysis Committee, I may say that a contrast quite as striking is found in regard to the amount of suspended organic matter in the air, and the quantity which is deposited from the air within these areas. Moreover, if we further examine the *nature* of the organic matter so occurring, it is found to be more noxious in the districts which, on all the evidence, appear to show the highest amount of pollution. Indeed, a careful enquiry into the nature of the organic matter in the air of thickly-populated districts and in dwellings would, I am sure, be of extreme value, and is worthy of the attention of those interested in the sanitary condition of our towns. Though it is not the province of this paper to deal with the air of dwellings, there is one point which is so much to the point in speaking of pollution by sulphur compounds, that I cannot omit it, more especially as it bears directly on the succeeding part of this paper, namely, the sulphur compounds which accumulate in the air of rooms lighted by Manchester coal gas. In March and April of last year, some analyses were made of the air of Professor Dixon's room at the Owens College. The dimensions of the room are 20 feet square and 13 feet high. Three burners, consuming about twelve cubic feet of gas per hour, were lighted at five in the evening, and then air was aspirated from different heights in the room between the hours of

seven and nine, and the sulphurous acid determined as in the case of the air analyses already quoted. The numbers are in parts per million, so that a direct comparison is possible between the values so obtained and those given for the air of the streets.

|                              |     |     |     |      |
|------------------------------|-----|-----|-----|------|
| At 6 inches from the ceiling | ... | ... | ... | 16·4 |
| At 20 „ „ „                  | ... | ... | ... | 13·4 |
| At 3 feet „ „                | ... | ... | ... | 7·8  |
| At 5 „ from the floor        | ... | ... | ... | 6·6  |

Thus, as a matter of fact, so enormous is the amount of sulphur in Manchester gas (it is usually at least double that allowed by the Metropolitan Act as a maximum) that the air of our rooms is liable to be as highly charged with sulphurous acid as the street air is in a moderately bad fog. It is probably only the relative dryness of the air which prevents it from becoming absolutely unbearable.

Thus far, then, in the face of the numbers given, I contend that my remarks amount to a demonstration that, as a means of discriminating between polluted and unpolluted air, and as a means of forming some estimate of the extent of pollution, the determination of the sulphurous compounds and of organic matter are much to be preferred to that usually adopted, viz., an estimation of the carbonic acid.

I may add that an equally convenient and, perhaps, even more valuable means lies in the direction of the estimation of the micro-organisms. Miquel, in Paris, has done much in this direction, but, though the difference between town and country air is very great, systematic experiments carried out at a sufficient number of stations in a town area have yet to be made before any general conclusions can be drawn.

But any plea for such a method of examination of air should have greater weight if it can be shown that the matters which it is proposed to determine are themselves injurious to life and health. Unfortunately the amount of

reliable information that we have is small; it is, however, increasing rapidly.

Aitken (*Proc. Roy. Soc. Edin.* XX. 76) gives results which go far to show that the *persistence* of town fogs (and it is the persistence which lends them their virulence) is due to the presence of sulphur compounds and mineral matters; and Frankland years ago suggested that the condensable hydrocarbons in air possess a similar property.

Oliver, in a report presented to the Royal Horticultural Society this year ("Effects of Urban Fog upon Cultivated Plants"), has shown that the presence of as little as 20 parts per million of sulphurous acid will, *if the light is also cut off to the extent to which in towns it is cut off*, bring about injuries to plants comparable to those which actually occur during fog. Also that mere traces of some hydrocarbons and of pyridine, impurities both found in polluted air and the deposits therefrom, are most injurious.

Then with regard to human beings, hardly a winter passes without the death-rate from respiratory diseases at times running up to three or four fold the normal. That this is due, in some measure at least, to the abnormal pollution of the air, such as has been indicated, is highly probable. It is a character practically confined to large towns; it is specially characteristic of densely populated districts where pollution of the air is most marked. Doubtless the prevalence of such ailments is largely affected by climatic conditions, and their seriousness aggravated by a lowering of tone of bodily health already established.

But this only raises the further question as to how far this very lowering of tone is the result of the constant inhaling of these minimal quantities of sulphur compounds, organic matter, and the like. Even though we are not yet in possession of sufficient information to enable us to speak decisively, there can be little room for doubt that the determination of these minor

constituents of town air and their further examination is worthy of more attention than has hitherto been given to it. And considering the importance of pure air, it would be well if such analyses of air were frequently and systematically carried out by sanitary boards as a matter of routine under some such scheme as the following :—

*Air of dwellings* in special cases ;

The estimation of carbonic acid gas, of organic matter and micro-organisms.

*Air of streets* ;

The estimation of sulphur compounds, of suspended organic matter, micro-organisms, and noxious gases.

---

Ordinary Meeting, October 17th, 1893.

Professor ARTHUR SCHUSTER, Ph.D., F.R.S., F.R.A.S.,  
President, in the Chair.

The thanks of the members were voted to the donors of the books upon the table.

Reference was made to the deaths, since the close of the previous session, of two of the Society's members—Dr. CHARLES CLAY, elected in 1841, and Mr. ARCHIBALD SANDEMAN, M.A., formerly Professor of Mathematics in Owens College, elected in 1851.

A bust of Dr. CLAY, executed in 1834, and presented to the Society by his executors in accordance with his wish, was exhibited.

Mr. FARADAY alluded to a peculiar deposit of dirt during foggy weather on the spinning cops of yarn in a mill. According to his informant, the deposit increased when the gas was lighted, and so convinced were the firm in question of this that they were proposing to fit up the mill with the electric light on this account alone. A discussion ensued in which Mr. N. BRADLEY, Mr. C. BAILEY, Mr. JOHN BOYD, Mr. ANGELL, Professor DIXON, and the PRESIDENT took part. It was variously suggested that the phenomenon might be due to the heat causing atmospheric currents, and thus bringing more of the polluted air into contact with the cops; to the fog preventing the escape of the products of combustion into the outer air; to the vaporisation of minute globules of water floating in the atmosphere, solid matter held by them being thus permitted to descend; to the greater density of the fog, when it became necessary to light the gas; and finally to the lighting of the gas merely making the collection of dirt on



the cops visible, and thus giving rise to the illusion that it was due to the lighting of the gas.

Professor H. B. DIXON, F.R.S., gave an account of M. MOISSAN'S isolation of fluorine, as experimentally illustrated at the meeting of the British Association at Nottingham.

The Rev. THOMAS P. KIRKMAN, M.A., F.R.S., read a paper on the "K-partitions of the R-gon."

---

[*Microscopical and Natural History Section.*]

Ordinary Meeting, October 9th, 1893.

Mr. PETER CAMERON, F.E.S., in the Chair.

Mr. HYDE referred to the past summer as having been highly favourable to the growth of maize in this country, and specially mentioned that grown in Alexandra Park, specimens of which were seven and eight feet in height with cobs in an almost ripe condition. Other plants noticed growing in the park were:—the castor oil plant, the tobacco plant, the mallow, the eucalyptus.

---

Ordinary Meeting, October 31st, 1893.

Professor ARTHUR SCHUSTER, Ph.D., F.R.S., F.R.A.S.,  
President, in the Chair.

The thanks of the members were voted to the donors of the books upon the table.

Mr. FARADAY exhibited some specimens of yarn as soiled by fog in the process of spinning.

Dr. LANGDON exhibited specimens of the salt of technical chlorophyll, which were believed to be the copper salt.

Professor WEISS exhibited raspberry canes bearing a second crop of fruit, and shoots of the apple bearing a second crop of flowers. He also exhibited specimens of a monstrous wallflower, which was considered by De CANDOLLE to be a separate variety, and named *Cheiranthus Cheiri*, var. *gynantherus*. The abnormal condition is due to the transformation of the stamens into carpels which are often fused round the true ovary.

Mr. P. J. HARTOG read a paper, by himself and Dr. HARKER, describing a form of apparatus by means of which they have measured the latent heat of steam. The authors wish the results, which have so far been very concordant and give a value distinctly lower than that found by Regnault, to be considered preliminary only, until they have been able to extend their observations.

A paper on a new sporiferous spike, apparently of the Calamarian type, from the Lancashire coal measures, by Messrs. T. HICK and JAMES LOMAS, was also read. The specimen was found near Oldham.

---

[*Microscopical and Natural History Section.*]

Ordinary Meeting, November 3rd, 1893.

R. ELLIS CUNLIFFE, President of the Section, in the Chair.

Mr. T. A. COWARD and Mr. C. OLDHAM were elected Associates of the Section.

Mr. ROGERS exhibited specimens of two rare mosses :— (A) *Physcomitrium sphaericum*, found growing on the mud margin of the reservoir at Whalley Bridge, the second locality in England ; (B) *Phycomitrella patens*, found on the mud margin of the reservoir at Chapel-en-le-Frith. Both were found by Professor Barker, late of Owens College, October, 1893.

Mr. ROGERS also exhibited fine specimens of fruit of *Pyrus japonica*, grown at Bowdon.

Mr. CAMERON made a short communication on galls, and exhibited a gall of the *Biorhiza aptera* from the roots of the birch from Edenbridge ; the birch being a new food plant, the others, apart from the oak, being beech, pine and vine. Also an elongated spindle-shaped woody gall on *Ulex nana* from Warwickshire. This gall is undescribed, differing altogether from the other gall on *Ulex* (*Aspondylia ulicis*) which is a bud gall.

Mr. J. COSMO MELVILL, M.A., F.L.S., exhibited specimens of *Wulfenia carinthiaca* (Jacq.) from South Tyrol, perhaps the most local of European plants, and compared it with its nearest allies, both European and exotic, in the sub-order *Digitaleæ* of *Serophulariaceæ*, which were also exhibited.

**On a New Sporiferous Spike from the Lancashire Coal Measures. By Thomas Hick, B.A., B.Sc., Assistant Lecturer in Botany, Owens College, Manchester, and James Lomax.**

*(Received October 31st, 1893.)*

The fossil which forms the subject of this communication was found by one of us at Moor Side, near Oldham, and has been derived from what is locally known as the Upper Foot Coal of the Lower Coal Measures, a layer which is practically identical with the Halifax Hard Bed in Yorkshire. Unfortunately only a single specimen was met with. From this two sections were prepared, both of which are longitudinal. One is nearly, but not exactly radial, except perhaps for a short distance at the base of the spike, while the other is so tangential as only to meet the axis at the upper extremity. The following description applies exclusively to the former section, unless the contrary is stated, but it contains nothing which is inconsistent with the other.

GENERAL CHARACTERS.

The section of the spike measures 4 centimetres in length by 8 or 9 millimetres in breadth. As it is not complete at either end, it was probably somewhat longer originally. The shape of the spike appears to have been cylindrical, but whether or not there was a narrowing at the ends it is impossible to say, nor is there anything to indicate its position on the parent plant.

Like many other carboniferous fruits it is composed of an axis and numerous lateral appendages (*Fig. 1*). The latter are of two kinds, sterile bracts (*Fig. 1, a, b, f*), and sporangiophores (*g, h*), placed at the nodes of the axis in

alternating whorls. In all 14 nodes, about 2.5 millimetres apart, can be counted, which originally bore whorls of sterile bracts, a few of which are present *in situ* in the section (*Fig. 1, a, b*). The number of bracts in each whorl cannot be made out with certainty, but it was probably small, and perhaps did not exceed 6 or 8. This estimate is based upon the appearance of the uppermost nodes, which are cut so tangentially that the anterior bracts are seen in transverse section (*Fig. 1, d*).

#### STRUCTURE OF THE AXIS.

The axis of the spike has a nearly uniform diameter of 1.17 millimetres throughout, and is obviously made up of a central cylinder (or stele) (*Fig. 1, s*), surrounded by a cortex (*Fig. 1, e*), but the structure of the parts is very imperfectly shown. The stele, 0.5 millimetres in diameter, is, in part at least, composed of elongated elements which here and there bear faint traces of vascular markings. But the whole cylinder is so black, and the state of preservation such, as to preclude any decisive statement as to the nature of these elements and as to whether the centre of the stele was or was not parenchymatous. At the nodes which bear the bracts the cylinder widens out a little, but the section shows no such expansions opposite the sporangiophores, perhaps because at these points the section is not radial to these structures. Neither in the case of the bracts nor in that of the sporangiophores, has any vascular connection with the stele been met with, but this is no proof that such did not originally exist, as it may be due to the divergence of the section from the radial direction.

#### THE CORTEX.

The cortex, whose thickness is 0.33 millimetres, is made up chiefly of large cells, elongated longitudinally. In the hypodermal region, the cells have thick walls and appear

to be prosenchymatous, so that their function was probably mechanical (*Fig. 2, a*). The inner cortex is made up of larger and thin-walled cells, and at certain points there are unmistakable evidences of the presence of canals or much elongated cells, in some of which are black carbonaceous contents similar to those met with in the young stems of *Arthropitys* and the sterile bracts of *Calamostachys Binneyana* (*Fig. 2, e*). At the sterile nodes the cortex is continued into the bracts in a way which will be described in dealing with the latter structures. Unfortunately these details cannot be illustrated by a figure, as they have been made out piece-meal from an examination of the cortex of both specimens, and are nowhere met with in combination.

#### THE STERILE BRACTS.

The members of the successive whorls of sterile bracts appear to have been superposed and not alternate. This is inferred from the fact that on one side of the spike the section has passed through five bracts in succession, and on the other side two successive bracts are superposed in two places.

The bracts stand out from the axis at nearly a right angle—having an extremely slight inclination upwards—for about three millimetres, and then turn upwards so abruptly that the limb is approximately parallel to the axis. The only evidence as to the presence or absence of cohesion at the base of the bracts is presented by the uppermost part of the section, which is tangential. It is not conclusive on the point, but it certainly proves that if cohesion does occur, it is restricted to the immediate neighbourhood of the axis, a conclusion, likewise, suggested by the second section.

As to the structure and form of the base of the bracts, little that is definite can be made out. The upper part would seem to consist of narrow, elongated, sclerenchymatous

elements (*Fig. 2, b*) continuous with the hypoderma of the internode *above*. The lower is composed of a large celled tissue with thin walls (*Fig. 2, d*), closely resembling that of the inner cortex and has no continuation of the hypoderma of the internode *below*. In one or two instances the resemblance to the inner cortex is emphasised by the presence of black masses in the cell cavities. From the appearance of the specimen, this softer tissue seems to have readily separated from the overlying harder part and to have been easily destroyed. The two layers together have a vertical thickness of 0.5 millimetres at the point of insertion on the axis.

The limb of the bract is a long slender body and probably reached to the second whorl of bracts above (*Fig. 1, b*). The structure of the limb is very imperfectly shown, but it seems to be made up of elongated, narrow, thick-walled elements, something like those met with in the upper part of the base. Whether or not it possessed a large-celled tissue like that of the lower part of the base, it is impossible to say, but it seems doubtful.

#### THE SPORANGIOPHORES.

The sporangiophores stood nearly, if not exactly, midway between the successive whorls of bracts, and projected at right angles from the axis. They are not found in the section however, and our knowledge of their position is based upon the short processes shown at *g*, which represent tangential sections of the basal portion. The section shows no trace of a peltate dilation of the distal end of the sporangiophore, an absence which is difficult to understand had such existed, unless it were remarkably small. For this reason we are inclined to think that the sporangiophores were simple columella-like structures. The histology cannot be made out with certainty, but there appears to have been a central strand of delicate tissue enclosed in an outer zone

of harder and more lignified elements (*Fig. 1, h*). This strand may have been a small vascular bundle, but there is no proof of this. As the section in passing more or less radially through the sterile bracts has missed most of the sporangiophores, we infer that the latter have alternated with the former. We have no information as to the number of sporangiophores in each whorl, but it was probably small.

### THE SPORANGIA.

The sporangia were arranged round the sporangiophores, but the number connected with each and the mode of attachment is not clearly shown. Where the section of the spike is radial two sporangia, one above the other, are seen between two successive whorls of bracts (*Fig. 1, sp.*). Where it is tangential, the appearances point to the presence of four sporangia for each sporangiophore (*Fig. 1, h*). The walls of the sporangia are composed of a single layer of cells, whose inner and radial walls are thickened (*Fig. 3, b*). In the surface view the cells are elongated and the longitudinal walls exhibit the projecting transverse processes so often met with in carboniferous sporangia (*Fig. 4*). No layer of thin walled cells is observable lining the interior, though this may be due to disappearance. The size of the sporangia cannot be definitely stated as they seem to have been cut in all directions, save those which would enable their principle axes to be measured. The one shown in *Fig. 1* at the base of the spike has a length of about 1.6 millimetres and a breadth of about 0.8 millimetres. The same is shown enlarged in *Fig. 3*, where the point of attachment is probably seen at (*a*).

### THE SPORES.

The spores are all of one size, averaging 0.066 millimetres in diameter, and are rounded in shape (*Fig. 3, c*). No



external markings can be made out on the walls, nor are they grouped in tetrads. The wall appears to be thickened, but this is probably due to the mode of preservation, and, in most cases, the contents remain as a central black mass, in which there are occasionally indications of a nucleus. They were probably mature and not in process of development at the time of mineralisation.

#### SYSTEMATIC POSITION.

Imperfect as the preceding description is, it seems sufficient to enable us to refer the new spike to the *Calamariaceae* rather than to the *Lycopodiaceae*, and hence its systematic position must be sought among the spikes of the former group. Unfortunately, the internal structure of these spikes is known in a few cases only, and the attempts to classify them by external characters alone, has not been very successful. Hence, any attempt to allocate the new spike to one of the groups into which the Calamarian fruits are divided can only be tentative and provisional, but this is no reason why the task should be avoided.

A comparison of the new spike with the well-known *Calamostachys Binneyana*, Schr., which is now known to be the fruit of some form of *Calamites*, reveals the fact that there is a close general agreement between the two, accompanied by differences of some importance. They agree in the alternation of sterile and fertile whorls of appendages; in the position of the sporangiophores, which stand midway between the successive whorls of bracts; and the number of sporangia associated with each. But the new fruit differs from *Calamostachys Binneyana* in the form, length, and, perhaps, number, of sterile bracts in each whorl; in the absence or great reduction of the sheath-like disk formed by the cohesion of the bracts; and probably in the absence of a peltate expansion at the distal ends of the sporangiophores. In addition, the spores are apparently

slightly larger, but this is, perhaps, of little importance, as exact measurements are, in most cases, difficult to make.

The precise value of these agreements and differences, from the systematists' point of view, is not easy to estimate, but we cannot be far wrong in regarding the former as of much greater value than the latter. To us, they seem sufficient to justify the inclusion of the new spike in the genus *Calamostachys*, which, as at present understood, is to some extent, a collective one. Acting upon this opinion, we propose that henceforth the fossil should be known as *Calamostachys Oldhamia*.

FIG. I.

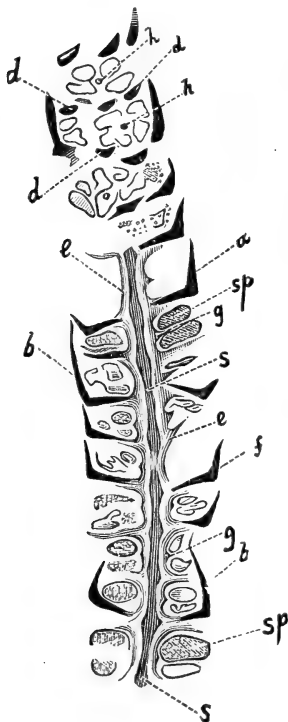

FIG. II.

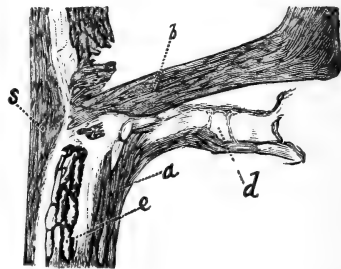

FIG. III.

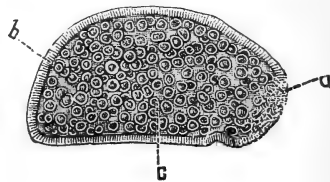

FIG. IV.



EXPLANATION OF THE FIGURES.

---

PLATE. FIG. 1. *Longitudinal Section of the Spike, three times the natural size.*

- s. Central Cylinder or Stele of the Axis.*
- e. Cortex of the axis.*
- a, b, f. Sterile bracts.*
- d. do. cut transversely.*
- g. Sporangiophores.*
- h. do. cut transversely.*
- sp. Sporangia with spores.*

FIG. 2. *Enlarged view of the base of the bract f FIG. 1 at its junction with the axis.*

- s. Central Cylinder or Stele of the Axis.*
- e. Inner portion of Cortex of Axis.*
- a. Outer do. do.*
- b. Upper portion of base of bract.*
- d. Lower do. do.*

FIG. 3. *Sporangia with Spores.*

- a. Probable point of attachment to Sporangiophore.*
- b. Wall of Sporangium.*
- c. Spores.*

FIG. 4. *Surface view of the Wall of a sporangium.*

---

General Meeting, November 14th, 1893.

Professor OSBORNE REYNOLDS, M.A., LL.D., F.R.S.,  
Vice-President, in the Chair.

Mr. R. L. TAYLOR, Science Master, Central Schools, Manchester, and Mr. HORACE LAMB, M.A., F.R.S., Professor of Mathematics, Owens College, Manchester, were elected as ordinary members.

---

Ordinary Meeting, November 14th, 1893.

Professor OSBORNE REYNOLDS, M.A., LL.D., F.R.S.,  
Vice-President, in the Chair.

The thanks of the members were voted to the donors of the books upon the table.

Dr. HODGKINSON exhibited a species of orchid (*Catasetum*), illustrating the extraordinary means by which fertilization by insect agency is effected in this group of plants. Experimental demonstrations with the antennæ were successfully given.

Mr. FRANCIS JONES, F.R.S.Ed., exhibited specimens of polished white marble exposed on the top of the Grammar School and at Alexandra Park for one year to atmospheric influences. The first-named specimen showed a loss of 1 per cent of its original weight, and the other a loss of 0·2 per cent.; whereas a third specimen kept in a room showed no loss whatever. The utility of the experiment as a test of the purity of air and its bearing on the wasting of exposed marble statues were pointed out.

Professor OSBORNE REYNOLDS read the following note "On Mr. HARTOG and Dr. HARKER'S Experiments on the Latent Heat of Steam at  $212^{\circ}$  Fahr." :—

"Since the publication of Regnault's experiments in 1848 there has been a general agreement as to the value of this important constant. And no one, in the meantime, has pointed out any source of error in Regnault's work. Whatever may be the true value of this latent heat an agreement as to the exact figure is of great importance. Otherwise by the use of different figures results into which this constant enters are thrown into discord. At the last meeting of this Society Mr. Hartog brought forward results of some very interesting experiments which show the latent heat to be something like 2% less than that obtained by Regnault. From the description, the experiments had evidently been made with the greatest care and the results obtained from different experiments are fairly consistent. Any source of error must therefore be some general loss of heat which would exercise the same effect on all the experiments. After hearing the paper it occurred to me that such a loss of heat must necessarily take place in the experiments from a cause which appeared to have been overlooked by the author of the paper. To this I now direct the attention of Mr. Hartog, in the hope he may be able, by removing it, to bring his results into accordance with Regnault's. The matter which seems to me to have escaped the attention of Mr. Hartog is the cooling effect on the interior tube of his apparatus, by which the steam passed into the calorimeter, of external radiation through the walls of his enclosing glass vessel. That this would cause a loss is certain; what this loss would be depends on the temperature of the room and on the constants of absorption of the surface of the interior tube and the glass envelope."

Messrs. HARTOG and HARKER replied to Professor REYNOLDS, pointing out that the loss by radiation could

only be very small, and nearly, if not quite, negligible, in their experiments. This loss, moreover, must in each case be proportional to the duration of the particular experiment. If, therefore, it were appreciable, other things remaining the same, the longer the experiment lasted, the lower would be the value found for *L*. But this was found not to be the case. A special experiment had been performed since the last meeting to test the validity of Professor REYNOLDS' objection, of which notice had been privately given. The results obtained confirmed the view expressed by the speakers.

Mr. LIONEL B. WELLS exhibited a map of the inland waterways of England and Wales prepared by himself and Mr. RUPERT SWINDELLS, and read a paper on "The Early History of the Inland Waterways of England and Wales, and their present condition, with suggestions for their Future Development." He pointed out that the shipping entered at British ports has increased within fifty years from 10,000,000 to about 130,000,000 tons, and that not one of the old waterways has secured its due proportion of this enormous increase of traffic. Of the existing waterways about 1,222 miles are controlled by railway companies, and 2,468 miles are "independent ;" yet the former group carry only one-fifth the total tonnage which passes along the entire system. The more important river navigations are the Weaver, the Aire and Calder, and the Severn. The improved sections of these have an aggregate of only 112 miles, yet they carry about one-eighth of the total inland waterway traffic of England and Wales, and the waterways controlled by the railway companies, though nine times as long, carry only 65 per cent more traffic. There are about 126 different lengths of waterways in the hands of about 100 proprietors, and if many of these would amalgamate, through water routes from east to west and from north to south could be established. With reference to the map it

was pointed out that as no complete map of the navigable waterways of the country could be exhibited at the International Congress on Inland Navigation which met in Manchester in 1890, Mr. WELLS and Mr. SWINDELLS had privately prepared the one exhibited, which showed that there are 740 miles of navigable waterways in the country of the existence of which the compilers of the Government returns of canals seemed to be unaware. Omitting large estuaries, the total length of canals and navigable rivers in England and Wales is 3,790 miles. With scarcely an exception the sills of the locks are below the navigable draught of the existing waterways, proving that the founders of the system looked forward to the ultimate deepening of the canals.

In the discussion which ensued Mr. FARADAY commented on the fact that it should have been left to the private enterprise of Mr. WELLS and Mr. SWINDELLS to produce the first complete canal map of England and Wales, and contrasted the neglect and imperfections of our own Government departments in this matter with Continental Government work, as illustrated by the specimens of canal maps issued by the French, Belgian, and other Governments exhibited by Mr. WELLS.

---

Ordinary Meeting, November 29th, 1893.

Professor ARTHUR SCHUSTER, Ph.D., F.R.S., F.R.A.S.,  
President, in the Chair.

The thanks of the members were voted to the donors of the books upon the table.

Professor LAMB, M.A., F.R.S., made a communication giving a mathematical explanation of the mode of propagation of waves through water by a moving object.

Mr. C. H. LEES read a note on the determination of the thermal conductivity of water.

Mr. HARRY GRIMSHAW, F.C.S., read a paper "On the treatment of sewage with basic persulphate of iron under varying conditions, more especially with regard to results obtained in Salford." From the experiments he concluded:— That the Salford sewage in June, 1893, was, in consequence of the long-continued drought, about 25 per cent more impure than the average. That while it is possible to vary the proportion of precipitants to such wide differences as exist between night and day sewage, it is not practicable on the large scale to meet the hourly fluctuations in the composition of the sewage of an industrial town ; during the working day, therefore, the maximum amount must be adhered to. That a too rapid flow through the tanks involves a greater expenditure of precipitants than is otherwise necessary, and that a flow of an average of about 10,000,000 gallons, or a maximum of 14,000,000 gallons, through tanks of a vertical area of 80ft. by 7ft. renders proper subsidence impracticable. That in cases of this kind the only remedy is either the use of excessive amounts of precipitants or the subsequent passage of the tank effluent through a straining filter or through land ; which



of the two is most economical being determined by local circumstances.

A discussion ensued, in which Mr. CORBETT, Mr. BARTON WORTHINGTON, Mr. WILLIAM THOMSON, and the PRESIDENT took part.

---

Ordinary Meeting, December 12th, 1893.

JAMES BOTTOMLEY, D.Sc., B.A., F.C.S., Vice-President,  
in the Chair.

The thanks of the members were voted to the donors of the books upon the table.

The CHAIRMAN referred to the death, since the last meeting, of Professor TYNDALL, an honorary member of the Society, elected 1868.

The SECRETARIES reported on the completion of the Joule Memorial statue by Mr. ALFRED GILBERT, R.A., originally promoted by the Council of the Society, and announced that the surplus funds, to the amount of £257.11s., had been handed over to the Society to be used for the commemoration of Joule's name, and that the books and documents of the Memorial Committee had been given to the Society for safe keeping.

Professor WEISS exhibited some pieces of wood taken from some gravel beds near Stockport. The wood was completely waterlogged and quite soft. Exposed to the atmosphere it became hard and black, lost its woody appearance, and showed a conchoidal fracture. It was

transformed into a substance like lignite, and burned like coal. A discussion on the character of the change in the wood and on the presence and absence of wood in peat bogs was participated in by Mr. C. BAILEY, Dr. BOTTOMLEY, and Dr. HODGKINSON.

The third part of Dr. W. C. WILLIAMSON'S "General, Morphological, and Histological Index" to his collective memoirs on the fossil plants of the coal measures was read.

A paper by Mr. J. C. MELVILL, M.A., F.L.S., on "*Wulfenia Carinthiaca*, Jacquin," was also read; and a paper "On the Osmotic Pressure of Solutions of Finite Concentration," by Dr. THOMAS EWAN.

---

**Preliminary Experiments on the Latent Heat of Steam at 100°C.** By P. J. Hartog, B.Sc. (Lond. and Vict.) Assistant Lecturer and late Berkeley Fellow in the Owens College, and J. A. Harker, D.Sc. (Tübingen) Berkeley Fellow in the Owens College. Communicated by Professor Arthur Schuster, Ph.D., F.R.S.

(Received December 12th, 1893.)

The latent heat of steam at 100°C. has been determined since the time of Black by a number of observers, Rumford (1), Ure (2), Watt (3), Despretz (4), Brix (5), Regnault (6) Favre and Silbermann (7), Andrews (8), Berthelot (9), and Schall (10).

We quote in the following table the results obtained by Regnault and subsequent observers:—

| Observer.                   | No. of Experiments. | Extreme Values of L. | Mean Value of L. |
|-----------------------------|---------------------|----------------------|------------------|
| Regnault ... ..             | 44                  | 533'3—538'4 (11)     | 536'67           |
| Favre and Silbermann ... .. | 3                   | 532'59—541'77        |                  |
| Andrews ... ..              | 8                   | 530'8 —543'4         |                  |
| Berthelot ... ..            | 3                   | 535'2 —537'2         | 536'2            |
| Schall ... ..               | no details.         | no details.          | 532              |

(1) Complete Works (Boston, 1875), Vol. II., p. 417.

(2) *Phil. Trans.*, 1818, Part II., p. 385.

(3) Robison's *Mechanical Philosophy*, ed. Brewster, Vol. II., p. 5 (1822).

(4) *Ann. chim. et phys.* [1] 24, p. 323 (1823), and *Traité élémentaire de physique*, p. 94, et seq. (1825).

(5) *Pogg. Ann.*, Vol. LV., p. 341 (1842).

(6) *Mémoires de l'Académie des Sciences*, Vol. XXI. (1847).

(7) *Comptes Rendus*, Vol. XXIII., p. 411 (1846). A few details are added in *Ann. chim. et phys.* [3] Vol. XXXVII., p. 464 (1853).

(8) *Q. J. Chem. Soc.*, Vol. I., p. 27 (1849).

(9) *Mécanique Chimique*, Vol. I., p. 296 (1879).

(10) *Ber. der deutschen chem. Gesellschaft*, Vol. XVII., p. 2199 (1884).

(11) If we exclude the first six experiments, which Regnault regarded as preliminary, the lower limit is 535'6. These experiments are, however, included in the calculation of the mean by the author. It should be added that Regnault gives the 'total heat' and not the latent heat. His actual figures exceed, therefore, by 100 units the numbers given here.

Excluding the numbers obtained by Berthelot, which we propose to consider immediately, it will be seen that no results have been published which can be regarded as a serious confirmation of those obtained by Regnault.

Regnault's experiments, however, were carried out on so large a scale, and with such elaborate precautions, and were moreover so numerous and concordant, that no one has since thought of calling them in question. The experiments of Berthelot quoted above were made, not to determine afresh, the latent heat of steam, but to verify by a comparison of his calculated results with Regnault's numbers, the validity of the assumptions made by him in using an admirably ingenious and simple apparatus, which he had devised for the purpose of determining the latent heat of vaporization of other liquids. Three years ago, on wishing to employ this apparatus, it appeared to the authors that an accurate calculation of the latent heat from the experimental results yielded by its use was a matter of extreme difficulty. In order to elucidate this point, it will be necessary to describe briefly the method of using M. Berthelot's apparatus, and to discuss in some detail the calculation of results from experiments of this kind.

In M. Berthelot's instrument (Cf. *Mécanique Chimique*, Vol. I. p. 288 et seq.), the boiler containing the liquid under examination consists of a glass flask, of which the neck is sealed up, the steam passing from its upper part vertically downwards, by means of a central tube sealed through the bottom, into the condensing worm. The condensing worm is fitted to the central tube by means of a ground joint, and is placed in a calorimeter immediately below the boiler. There is thus free communication throughout the experiment between the boiler and the condenser. The source of heat is a small ring-burner placed under the flask and over the calorimeter. The latter is protected as far as possible from radiation by means of suitable screens.

The experiment is carried out as follows :—

The liquid is introduced into the boiler, the two portions of the apparatus are fitted together, and the screens, etc., properly arranged. The burner is then lighted, and the thermometer in the calorimeter is read at intervals of a minute, until the experiment is concluded. The moment when the liquid is observed to boil marks the end of the 'preliminary period,' and up till this time the march of the thermometer per minute has been small ( $\cdot 02^\circ$  to  $\cdot 03^\circ$ , or less). The liquid is then allowed to boil until the rise of temperature produced by the condensation is thought to be sufficient. At this point the flame is extinguished, the boiler is removed, and the condensing worm is corked up. After a short time the march of the thermometer again becomes slow and regular, and during this final period is "exactly the same as that of a thermometer placed in the same calorimeter, filled with the same quantity of water taken at the final temperature, but without any previous heating of the screens; a march carefully ascertained by preliminary experiments." (*Méc. Chim.* I., p. 294.)

Now let us see how the latent heat of steam can be deduced from these observations.

If  $L$  = the latent heat of steam for the temperature  $T$ ,  
at which the water boils under the pressure prevailing at the time of the experiment ;

$W$  = the weight of water condensed ;

$w$  = the calorific equivalent of the calorimeter and its contents at the beginning of the experiment ;

$t_0$  = the initial temperature of the calorimeter at the beginning of the condensation ;

$t_f$  = the final temperature which the calorimeter would possess if no heat were lost or gained except that due to the condensation of the steam ;

We may write that

$$WL + W(T - t_f) = w(t_f - t_o)$$

or

$$L = w \frac{(t_f - t_o)}{W} - (T - t_f).$$

If we take account of the changes in specific heat of the bodies concerned, between the limits of temperature which enter into the experiment, and if  $C$  = the sp. heat of water, and  $c$  = the calorific equivalent of the calorimeter and contents, both being expressed as functions of the temperature, we have

$$L = \frac{w \int_{t_o}^{t_f} c dt}{W} - \int^{T} C dt$$

The variation of specific heat with temperature will affect mainly the second term, as the interval  $(t_f - t_o)$  is always small. The differences between the results of different observers do not allow of this correction being accurately taken into account at present, and it is not likely to affect the value of  $L$  to more than the extent of  $\frac{1}{500}$  part.

The first difficulty which presents itself with the apparatus of M. Berthelot is the determination of the initial temperature  $t_o$ . During the preliminary period, the thermometer in the calorimeter is rising, owing to the radiation from above. At a certain moment the rate of the rise will shew a sudden increase, namely, when the first portion of vapour is condensed. But this will certainly occur before the liquid begins to boil. M. Berthelot, however, takes as his initial temperature the

temperature at which boiling begins. It would seem that this is not perfectly easy to fix. With regard to this point see Regnault, loc. cit. p. 659.

But the gravest difficulty consists in calculating  $t_f$ . In order to do this we need to know two things:—(1) The temperature  $t_r$  at the moment when, all condensation having previously ceased, the contents of the worm have acquired the same temperature as the water in the calorimeter, and (2) the amount of heat gained or lost by the calorimeter by radiation, surface evaporation, etc., from the beginning of the condensation to the moment when the temperature  $t_r$  is attained. This amount of heat would produce a change of temperature called the "total correction."

We can ascertain by special experiments how long a time must elapse before the difference of temperature between the contents of the worm and the calorimeter is negligible. This does not amount to more than two or three minutes, and we can, in a well-conducted experiment, ascertain the precise moment when this occurs with sufficient certainty by noticing when the march of the thermometer becomes regular.

For the calculation of the total correction, M. Berthelot has himself given elsewhere a method which is irreproachable, since it is independent of any assumption (See *Mécanique Chimique*, Vol. I., p. 208). The correction for each minute is a function of the mean temperature of the calorimeter during that minute, and M. Berthelot determines this by a series of blank experiments performed throughout the whole range of temperature traversed during an actual determination. It is, however, evidently necessary for the accurate use of this method that external conditions, on which radiation and evaporation depend, shall remain the same during the blank experiments and the actual determination. Hence it is impossible, to make a blank experiment of this kind with the

apparatus described, for if we have the gas burner above the calorimeter alight, as it is during a determination, there is no means of preventing the liquid from condensing in the calorimeter. Thus the Berthelot correction cannot be applied.

The other method of correction in use is that of Regnault and Pfaundler. It assumes that the change in the temperature-rise (or fall, as the case may be) per minute is proportional to the change of temperature.

Suppose during the preliminary period that we observe the thermometer for  $n$  minutes, during which time it rises through the *small* interval  $t_q - t_o$ . Then we may assume that at the mean temperature

$$\frac{t_q + t_o}{2}$$

the rise per minute would be

$$\frac{t_q - t_o}{n}$$

This last quantity we call the *initial correction*.

Again in the final period the thermometer rises during  $m$  minutes through the small interval  $t_s - t_r$ . Then similarly we call the *final correction* the quantity

$$\frac{t_s - t_r}{m}$$

corresponding to the mean temperature

$$\frac{t_r + t_s}{2}$$

We then plot out temperatures as abscissæ, and the corrections corresponding to those temperatures as ordinates.



CORRECTIONS.

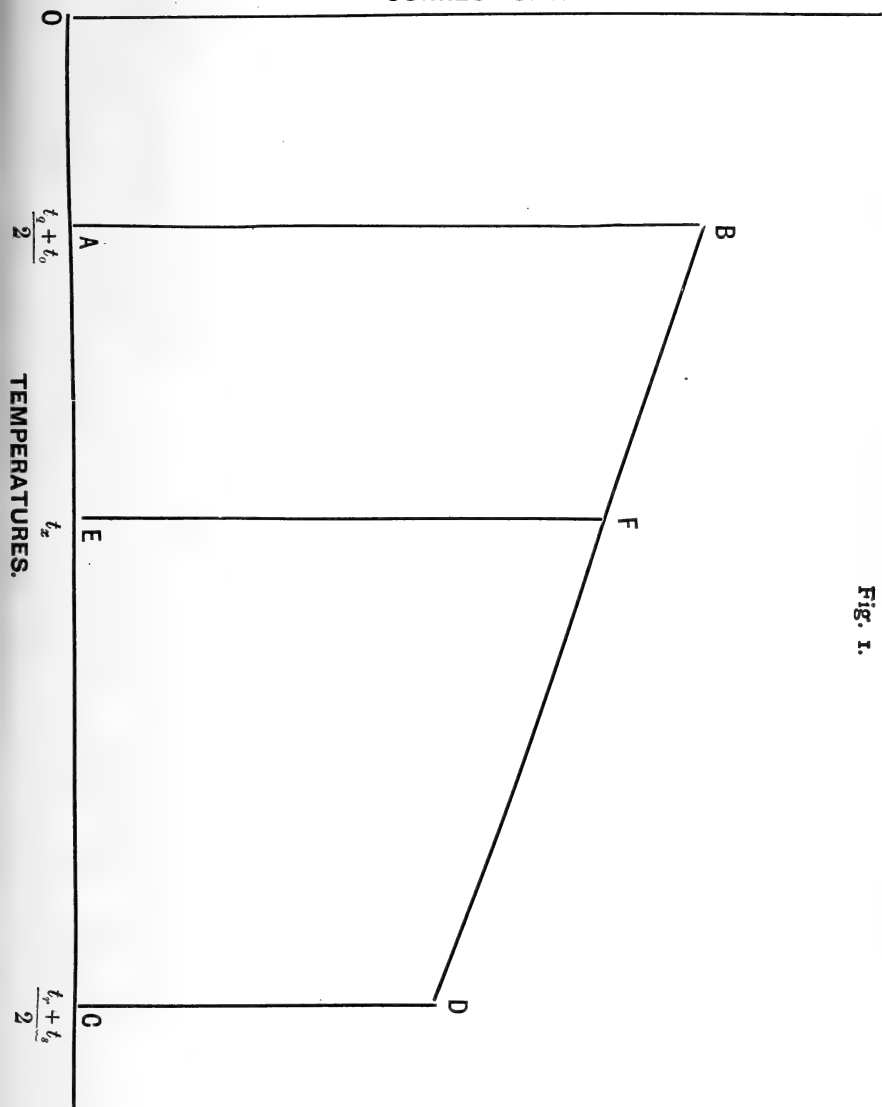

Fig. 1.

In Fig. 1, if AB and CD represent the corrections for the temperatures

$$\frac{t_q + t_o}{2} \text{ and } \frac{t_r + t_s}{2},$$

Regnault and Pfaundler assume that the correction for any intermediate temperature  $t_x$ , corresponding to the abscissa OE, is represented by the ordinate EF drawn to meet the straight line BD in F.

For this assumption to be valid two things are necessary:—

- (1) That the change of temperature of the calorimeter should not exceed  $3^\circ$  or  $4^\circ$ ; this condition is satisfied both in M. Berthelot's experiments and in those performed by us; and
- (2) That the temperature of the bodies radiating heat to the calorimeter should remain approximately constant.

It is evident that we cannot possibly assume the correction to be merely a function of the temperature of the calorimeter, if we suddenly bring a hot body into its vicinity during the course of our observations. In M. Berthelot's apparatus, we do the reverse; we suddenly take away the hot burner which was radiating heat to the calorimeter during the actual observation. It is difficult to see how the observation of the march of the thermometer after this removal can serve as a datum for the calculation of the correction to be applied for the period of actual condensation, during which the thermal conditions were so different.

We proceed to describe the modified form of apparatus [Fig. 2] which we have adopted in order to be able to use either of the methods of correction just quoted.

The boiler consists of a flask A, through which the tube BC passes centrally. The upper end of BC is ground conically to fit into a hollow cap D, which is itself attached by a glass rod to the movable bell E. This bell fits loosely into a rim, which is filled with mercury so as to form a lute. The bell and cup may thus be raised or lowered at will, so as to open or close the valve at C, through which the steam passes

downwards through CB into the condensing worm W. At F a side tube is connected with a condenser, if desirable, by means of an indiarubber tube fitted with a clip. The tube at F is kept open during the preliminary period; it is shut just after C is opened, and opened again just before C is closed, so that at no period does the internal pressure exceed that of the atmosphere. The end B of the tube BC is ground into the upper end of the condensing worm, of which the construction differs slightly from that of Berthelot. The steam in our apparatus enters the condensing worm by the straight portion, and not by the spiral. We found this alteration necessary as, after the closing of the valve, the air entering the worm tends otherwise to drive the condensed water back into BC.

The lower half of A was surrounded by a piece of copper gauze bound on with asbestos string, and the lower portion of the tube BC was surrounded in Expts. I., II., III. by asbestos, and in IV. and V. by a leaden steam-coil wrapped closely round it.

The boiler was heated by a small ring burner, of which the flame was kept at a perfectly constant height from the moment of lighting till it was extinguished. The gas was passed first through a Moitessier glycerine regulator (which maintains the pressure constant to within a half millimetre of water), and then through a tap fitted with a long handle moving in front of a graduated circle.

These precautions are necessary for accurate measurements, as variations in the height of the flame naturally

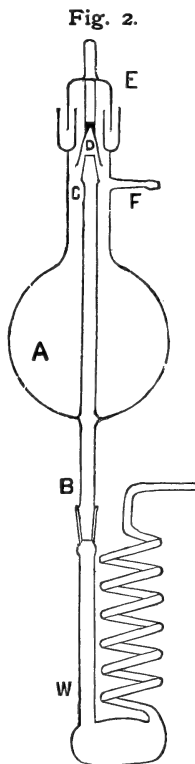

cause the radiation to the calorimeter to vary. We were able to regulate the amount of this radiation at will ; but, of course, too small a flame made the determination too slow, too large a flame the initial and final corrections too high. The calorimeter and its jacket, and the thermometer were protected from excessive radiation by means of screens of asbestos board.

The calorimeter itself consisted of a copper vessel weighing 282 grammes. The general arrangement of the calorimeter and jacket was practically identical with that employed by Berthelot.

The stirrer consisted of a ring of copper pierced with several holes, and moved up and down on glass guides fixed into a light wire frame, which served to protect the glass worm from any accidental blow. It was moved by means of an electro-motor, and a wheel and crank mechanism.

The thermometer used was one by Baudin, of Paris (No. 12,771, metastatic), divided into  $\frac{1}{50}$ ths of a degree centigrade. It was compared with an instrument calibrated by Dr. Schuster, and compared by him with a thermometer standardized at the International Bureau of Weights and Measures at Sèvres. It was read by means of a telescope, and the 20th part of a division, *i.e.*, the  $\frac{1}{1000}$ th part of a degree was estimated.

The actual *modus operandi* was as follows :—The water was first boiled in the flask with the valve at C closed, and the steam escaping (not condensed). The thermometer was read from this time forward at the end of each half minute. When the march of the thermometer had become regular for some minutes, the valve was opened and the exit F closed. The steam then condensed in the worm. When it was thought that sufficient steam had been condensed, the total rise being from 3 to 4 degrees, the exit was opened, and the valve closed, and thermometric observations were only discontinued when the march of the

thermometer again became regular. The flame was then extinguished, and the worm was detached, corked, carefully wiped, and allowed to remain in the balance-case for some time before weighing. The error on the determination of the weight of the water condensed in the worm could not exceed one part in 10,000. We made a special blank experiment without condensation, to ascertain if the Regnault-Pfaundler corrections were applicable, and found this to be the case.

We give below the readings of the thermometer during one experiment (No. 1).

[The first readings given are those taken after the water had been boiling for 20 minutes.]

| Time.<br>h. m. | Reading.    | Notes.                   |
|----------------|-------------|--------------------------|
| 4 6 ...        | 14° 524 ... | } Preliminary period.    |
| 4 6½ ...       | 14° 532 ... |                          |
| 4 7 ...        | 14° 540 ... |                          |
| 4 7½ ...       | 14° 547 ... |                          |
| 4 8 ...        | 14° 556 ... |                          |
| 4 8½ ...       | 14° 564 ... |                          |
| 4 9 ...        | 14° 573 ... |                          |
| 4 9½ ...       | 14° 582 ... |                          |
| 4 10 ...       | — ...       | Valve opened 4h. 9' 50". |
| 4 10½ ...      | 14° 77 ...  | —                        |
| 4 11 ...       | 15° 02 ...  | —                        |
| 4 11½ ...      | 15° 26 ...  | —                        |
| 4 12 ...       | — ...       | Reading missed.          |
| 4 12½ ...      | 15° 72 ...  | —                        |
| 4 13 ...       | 15° 97 ...  | —                        |
| 4 13½ ...      | 16° 22 ...  | —                        |
| 4 14 ...       | 16° 46 ...  | —                        |
| 4 14½ ...      | 16° 70 ...  | —                        |
| 4 15 ...       | 16° 93 ...  | —                        |
| 4 15½ ...      | 17° 18 ...  | —                        |
| 4 16 ...       | 17° 40 ...  | —                        |
| 4 16½ ...      | 17° 64 ...  | —                        |
| 4 17 ...       | 17° 86 ...  | —                        |

| Time. |     | Reading. |        | Notes.          |
|-------|-----|----------|--------|-----------------|
| h.    | m.  |          |        |                 |
| 4     | 17½ | ...      | —      | Valve closed.   |
| 4     | 18  | ...      | 18·140 | —               |
| 4     | 18½ | ...      | —      | Reading missed. |
| 4     | 19  | ...      | 18·170 | —               |
| 4     | 19½ | ...      | 18·176 | —               |
| 4     | 20  | ...      | 18·181 | —               |
| 4     | 20½ | ...      | 18·184 | —               |
| 4     | 21  | ...      | 18·187 | —               |
| 4     | 21½ | ...      | 18·192 | —               |
| 4     | 22  | ...      | 18·197 | } Final period. |
| 4     | 22½ | ...      | 18·201 |                 |
| 4     | 23  | ...      | 18·205 |                 |
| 4     | 23½ | ...      | 18·209 |                 |
| 4     | 24  | ...      | 18·214 |                 |
| 4     | 24½ | ...      | 18·217 |                 |
| 4     | 25  | ...      | 18·220 |                 |
| 4     | 25½ | ...      | 18·223 |                 |

Rise of thermometer per minute during initial period (4h. 6' to 4h. 9½') = 0·165°.

Mean temperature of initial period = 14°·553.

Rise of thermometer per minute during final period (4h. 22' to 4h. 25½') = 0·0074°.

Initial temperature of calorimeter (4h. 9' 50" = 14·588°

Final                   "                   "                   (4h. 22' = 18·197

---

$$\Delta t \dots \dots \dots = 3·609$$

From the above data we can calculate graphically, in the way described, the correction to be applied for each successive half-minute of the middle period; and we thus find that the total correction is 0·118°.

The corrected temperature - difference is therefore (3·609 - 0·118) = 3·491°.

The other data of the experiment were as follows:—

|                                                                |              |         |            |
|----------------------------------------------------------------|--------------|---------|------------|
|                                                                |              | Sp. ht. | Water eqt. |
| Weight of copper calorimeter...                                | 284.5        | 0.0933  | 26.54      |
| „ brass stirrer ... ..                                         | 87           | .086    | 7.50       |
| „ glasswormandguides                                           | 46.8         | .017    | 7.87       |
| Thermometer ... ..                                             | ...          | ...     | 1.10       |
| Water in calorimeter (corrected<br>for buoyancy in air) ... .. | ...          | ...     | 1717.00    |
|                                                                | Total ... .. | =       | 1760.01    |

Barometer-reading, 762.4mm. B.P. of water = 100°.07.

Weight of water condensed = 10.122 grammes.

We have then

$$L = \frac{3.491 \times 1760}{10.122} - (100.07 - 18.20)$$

$$= 525.13 \text{ cal.}$$

We give in the following table the experimental details of five experiments (including the one just quoted).

|                                                     |        |        |        |        |        |
|-----------------------------------------------------|--------|--------|--------|--------|--------|
| 1. Number of Experiment .....                       | I.     | II.    | III.   | IV.    | V.     |
| 2. Water-equivalent of calorimeter and contents ... | 1760.0 | 1723.2 | 1749.2 | 1743.4 | 1681.0 |
| 3. Temperature of steam .....                       | 100.07 | 100.07 | 100.36 | 100.30 | 100.00 |
| 4. Initial temp. of calorimeter .....               | 14.588 | 13.027 | 12.968 | 12.528 | 14.948 |
| 5. Final temp. of calorimeter ( $t_r$ )...          | 18.197 | 17.577 | 16.330 | 16.206 | 16.062 |
| 6. Observed temperature - difference .....          | 3.609  | 4.550  | 3.362  | 3.678  | 1.114  |
| 7. Total correction .                               | — .118 | — .134 | — .127 | — .239 | — .123 |
| 8. Duration of experiment in minutes.               | 12     | 15     | 8¼     | 13½    | 5½     |
| 9. Weight of water condensed, in grammes .....      | 10.122 | 12.546 | 9.278  | 9.854  | 2.742  |
| 10. Value of L .....                                | 525.13 | 524.07 | 525.87 | 524.33 | 523.61 |
| Mean value of L deduced from experiments I.—V. =    | 524.60 |        |        |        |        |
| „ „ „ „ „ I.—IV. =                                  | 524.85 |        |        |        |        |

In the above calculations we have taken our heat unit as

the amount of heat required to raise one gramme of water through  $1^{\circ}$  of the hard-glass mercury thermometer in the neighbourhood of  $15^{\circ}$  C.

It will be observed that our results differ from those of Regnault by more than 2 per cent. We have failed so far to discover any explanation of this difference, either by ascertaining an appreciable error in our own work or in that of the great French physicist. Professor Osborne Reynolds has suggested that radiation from the inner surface of the central glass tube must cause a certain amount of condensation on its surface, and that the water so condensed would run down into the worm, and thereby cause an error of calculation possibly sufficient to account for the difference between our results and those of Regnault. The heat radiated into a vacuum by a square centimetre of glass at  $100^{\circ}$  has been determined by Grätz (*Wied. Ann.*, Vol. XI., p. 913), and the absorption by glass of heat radiated from a Leslie cube heated to  $100^{\circ}$  by Melloni (quoted by Wüllner, *Lehrb. d. Experimental Physik*, Vol. III., p. 197), so that we can form an estimate of the loss due to this source, and calculation shows that the loss falls in all probability well within the error of experiment. This conclusion is borne out by the fact that the amount of water condensed by radiation must be proportional to the duration of the experiment; while a glance at the table shews that, other things being approximately the same (see *e.g.* Expts. III. and IV.), the results of experiments, calculated without taking account of this correction, are independent of duration. We are, however, obliged to Professor Reynolds for his criticism, and shall meet it by making use of metal vessels in the experiments which are in progress.

It may here be pointed out that the determinations of Regnault for the latent heat of steam at  $0^{\circ}$  have not been confirmed by subsequent observers [see Winkelmann (*Wied. Ann.*, Vol. IX., p. 208, 1880) and Dieterici (*ibid.*, Vol.



XXXVII., p. 494, 1889)]; but on this point no agreement as yet exists.

It occurred to us that our results might be controlled by the experiments made by Joly with his ingenious steam calorimeter. (*Proc. Roy. Soc.*, Vol. XLI., p. 352 (1886), and Vol. XLVII., p. 219 (1889). By the use of this instrument we can calculate the specific heat of a body if we suppose the latent heat of steam to be known, and its author used it for this purpose; and, inversely, we can also use it to calculate the latent heat of steam if we assume the specific heat of the bodies experimented on to be known. Unfortunately the specific heat even of bodies like silver, which are easily obtained in the pure state, is not known with the requisite accuracy. Thus Regnault gives for the sp. heat of silver 0.05701, Kopp gives 0.056, and Bunsen gives 0.0559. (The numbers are quoted from Joly, *Proc. Roy. Soc.*, XLI., p. 358.)

In order to use the Joly calorimeter for our purpose it is evidently necessary that we should make use of a particular body of which the specific heat has been determined immediately beforehand with the water calorimeter. This we propose to do shortly.

The other means at our disposal for controlling our numbers is less direct.

A well-known equation in thermodynamics gives us a relation between

L, the latent heat of steam at the absolute temperature  $T^{\circ}$ ,

$(s' - s)$ , the difference between the specific volumes of saturated steam and water at  $T^{\circ}$ ,

$\frac{dp}{dT}$ , the differential coefficient of the vapour tension of water with regard to the temperature, at  $T^{\circ}$ ,  
and

J, the mechanical equivalent of heat, namely:—

$$L = \frac{T}{J} (s' - s) \frac{dp}{dT}$$

The quantities  $J$  and  $s'$  are by no means easy to measure, nor have we space to discuss the values obtained for them by different observers. There is, however, reason to believe that the value for  $J$  given by Griffiths (*Phil. Trans.*, 1893, p. 493), viz.,  $4.194 \times 10^7$  C.G.S. units, is within  $\frac{1}{1000}$  of the truth. The experiments of Perot (*Ann. Chim. Phys.* [6] XIII., p. 159) were performed with extreme care, and we accept his value for the specific volume of steam at  $99.60^\circ\text{C}$ ., namely, 1657cc.

We have used two formulae to calculate  $dp/dT$  from Regnault's experiments, which give results differing by less than 1 per thousand. That of Moritz gives  $dp/dT = 3.58574 \times 10^4$  C.G.S. units; that of Roche gives  $dp/dT = 3.58318$  C.G.S. units, taking  $g = 980.67$ .\*

If we calculate out  $L$  with the values given, we find that with Moritz's number  $L = 527.54$  calories, with Roche's number,  $L = 527.16$  calories, for the temperature  $99.60^\circ\text{C}$ . (which we choose because Perot's determination was made at that temperature). At  $100^\circ$  the value of  $L$  would be somewhat less (about half a unit, if Regnault's interpolation formula is approximately correct.)

These numbers agree well with the one obtained by us, viz., 524.8, but at the same time, we should hesitate to regard this confirmation as conclusive.

\* Moritz's formula, quoted by Willner, *Lehrbuch der Experimental-Physik*, Vol. IV., p. 683, is as follows:—

$$\log_{.10} p = a + b\alpha^2 - c\beta^2$$

where  $p$  = pressure in *mm* of mercury,  $t$  = temperature centigrade.

$$\log_{.10} a = .006864937$$

$$\log_{.10} \beta = \bar{1}.996725536$$

$$\log_{.10} b = \bar{2}.131990711$$

$$\log_{.10} c = 0.611740767$$

$$a = 4.7393707.$$

Roche's formula, quoted by Hirn, *Théorie Mécanique de la Chaleur*, T. I., pp. 323, 325, is as follows:—

$$\frac{dp}{dT} = \frac{0.090936948p}{[1 + 0.0049528167(20 + t)^2]}$$

We are at present engaged in repeating our determinations with an apparatus made chiefly of metal. In the new model we have replaced the gas burner by a coil of wire placed within the boiler, and heated electrically. By this means, we hope to reduce the radiation to the calorimeter, and consequently the correction, very considerably, and thereby to increase the accuracy of our results.

We have, in conclusion, to tender our thanks to Professor Schuster and Mr. H. E. Hadley, B.Sc., for assistance given in the course of our work, and especially to Mr. S. H. Davies, B.Sc., who took part in a tedious series of preliminary rough experiments, of which no account is given here.

---

**General, Morphological, and Histological Index to the Author's Collective Memoirs on the Fossil Plants of the Coal Measures. Part III. By William Crawford Williamson, LL.D., F.R.S., &c., Foreign Member of the Royal Swedish Academy; Corresponding Member of the Royal Society of Göttingen.**

(Received December 12th, 1893.)

LIST OF WORKS

ON THE ORGANISATION OF THE

**FOSSIL PLANTS OF THE COAL MEASURES,  
AND GENERAL INDEX TO THEIR CONTENTS.**

ROYAL SOCIETY SERIES, I. TO XIX.

*Symbols. Parts.*

- A. I. Calamites and suggested genus Calamopitus (not subsequently insisted upon). Figs. 16 and 17 do not belong to Calamites but to the subsequently adopted genus Astromyelon. *Phil. Trans.*, 1871.
- B. II. Lepidodendron selaginoides, Diploxyton (Corda), Ulodendron, Favularia, Sigillaria, Stigmara, Lepidodendroid Cone (?) ultimately Lepidodendron parvulum. (*Memoir XVI.*) Anabathra. *Phil. Trans.*, 1872.
- C. III. Lepidodendron brevifolium, (Burntisland form) and its Lepidostrobus. Restoration of Lepidodendron. *Phil. Trans.*, 1872.
- D. IV. Lyginodendron Oldhamium; Heterangium Grievii. *Phil. Trans.*, 1873.
- E. V. Asterophyllites with Sphenophylloid axis. Sphenophyllum. Volkmanina (now Sphenophyllum) Dawsoni, Strobilus of Asterophyllites (subsequently Paracalamostachys Williamsoniana; Weiss) Asterophyllites fruit (subsequently Palæostachya pedunculata. (See Weiss. Steinkohlen-Calamarien). Calamostachys Binneyana, Calamites verticillatus. Root of Asterophyllites (afterwards Amyelon). *Phil. Trans.*, 1874.
- F. VI. Rachiopteris aspera (afterwards petiole of Lyginodendron Oldhamium) Rachiopteris Oldhamium, Rachiopteris duplex, Rachiopteris Lacattii, Rachiopteris bibractensis, Anachropteris Decaisnii. *Phil. Trans.*, 1874.
- G. VII. Myelopteris (Medullosa of Cotta), Psaronius Renaultii, Kalyon Hookeri (now known to be root of Lyginodendron). *Phil. Trans.*, 1876.

- H. VIII. *Rachiopteris corrugata*, Fern Sporangia, Gymnospermous Dadoxylon, Gymnospermous Seeds, *Lagenostoma ovoïdes*, *Lagenostoma physoides*, *Conostoma oblonga*, *Conostoma ovalis*, *Conostoma intermedia*, *Malacotesta oblonga*, *Trigonocarpon olivæforme*, *Hexapterospermum Nöggerathi*, *Cardiocarpon anomalum*, *Cardiocarpon compressum*, *Cardiocarpon acutum*, *Cardiocarpon Butterworthii*, *Polyptospermum*. *Phil. Trans.*, 1877.
- I. IX. *Astromyelon*, subsequently *A. Williamsonis* (and now known to be the root of *Calamites*), *Calamites*, *Asterophyllites*, *Lepidodendron selaginoides*, *Lepidostrobus*, *Macrosporites*, *Rachiopteris cylindrica*, *Cordaites* (?) epiderm, *Lyginodendron* (?) *anomalum*, *Lepidodendroid cortex*, *Oidospora anomala*, *Volkmania* (?) *parvula* (now *Lepidodendron parvulum*), *Lepidodendron Spenceri*. *Phil. Trans.*, 1878.
- K. X. *Arran Lepidodendron*, subsequently *L. Wunschianum*, *Lepidodendron Spenceri*, *Heterosporous Lepidostrobus*, *Calamostachys Binneyana*, *Rachiopteris insignis*, *Tylosis*, *Rachiopteris robusta*, *Sporocarpon elegans*, *Sporocarpon*, *pachyderma*, *Sporocarpon asteroides*, *Sporocarpon ornatum*, *Traquaria*, *Zygosporites* (subsequently shewn to be spores), *Dadoxylon*, *Lagenostoma ovoïdes*, *Cardiocarpon anomalum*, *Calcsiphæra* (*Radiolaria* of Judd) *Rachiopteris di-epsilon*. *Phil. Trans.*, 1880.
- L. XI. *Lepidodendron selaginoides*, *Lepidodendron Harcourtii*. (The plant so named here is now designated *L. fuliginosum*. See *Proceedings Royal Society*, Vol. XLII., p. 6). *Stigmariam* rootlets. Medullary rays of *Lepidodendron selaginoides*, *Calamostachys Binneyana* and *C. Casheana*, *Fungi*. *Phil. Trans.*, 1881.
- M. XII. *Astromyelon Williamsonis* (now root of *Calamites*), *Psaronius Renaultii*, *Zygosporites* (in a Sporangium), *Calamites*, *Lepidodendron*, *Halonia*, *Sporocarpon ornatum*, *Salisburia Adiatifolia*. *Phil. Trans.*, 1881.
- N. XIII. *Heterangium Tiliæoides*, *Kaloxylon Hookeri* (now root of *Lyginodendron*). *Phil. Trans.*, 1887.
- O. XIV. True fructification of *Calamites*. *Phil. Trans.*, 1883.
- P. XV. *Rachiopteris Grayii*, *Rachiopteris Lacattii*; *Calamostachys Binneyana*, *Rachiopteris hirsuta*, *Rhizonium verticillatum*, *Rhizonium reticulatum*, *Rhizonium lacunosum*.
- Q. XVI. *Lepidodendron fuliginosum*, *Lepidodendron mundum*, *Lepidodendron Spenceri*, *Lepidodendron parvulum*, *Rachiopteris inæqualis*. *Phil. Trans.*, 1889.
- R. XVII. *Lyginodendron Oldhamium*, *Bowmanites* (*Volkmania*) *Dawsoni*, now *Sphenophyllum Dawsoni*, *Calamites*. 1890.
- S. XVIII. *Bowmanites* (now *Sphenophyllum*) *Dawsoni*. *Rachiopteris ramosa*, possibly *R. hirsuta* var. *ramosa*.
- T. "On the structure of the woody Zone of an undescribed form of *Calamite*." *Memoirs of the Manchester Literary and Philosophical Society*, 3rd Series, Vol. IV., Session 1868-9.
- V "On a new form of *Calamitean Strobilus*." *Memoirs of the Manchester Literary and Philosophical Society*, 3rd Series, Vol. IV., Session 1869-70.

- W. "On some Anamolous Oolotic and Palæozoic forms of vegetation." Royal Institution of Great Britain, Weekly Evening Meeting, Feb. 16, 1883.
- X. "On the relations of Calamites to Calamodendron," with description of an intermediate form. *Memoirs of the Manchester Literary and Philosophical Society*, 3rd Series, Vol. X., 1886-7.
- Y. A Monograph on "the Morphology and Histology of Stigmaria ficoides." *Palæontographical Society*, Volume for 1886.
- Z. "On the Structure and Affinities of some Exogenous stems from the Coal measures." *Monthly Microscopical Journal*, Aug. 1, 1869.
- AA. "On the Organisation of the Volkmania (now Sphenophyllum Dawsoni).
- BB. XIX. *Lepidodendron Harcourtii Brongniart*, *Halonina*, *Ulodendron*, *Lepidophlois*, *Lepidostrobi*, *Lepidodendron Spenceri*. *Phil. Trans.*, 1893.

## INTRODUCTION.

The Carboniferous Plants that I propose to deal with in Part III. of this Index are the Ferns. Seeing that fronds of this group are so extremely abundant in most of the shales and sandstones of the Coal measures, it might have been expected that their stems, branches, and petioles would be equally so in our calcareous nodules; but, unfortunately, this is not entirely the case; yet they are not wholly wanting, but such as we do obtain are usually fragments of stems, petioles, and the secondary and ternary branches of fronds. It is extremely rare to find any of these accompanied by their leaves or leaflets. Hence, it is often very difficult to determine whether or not the objects we are studying belong to the Filicine group. There are certain well-known localities where fragments of stems are more abundant than elsewhere, which stems unmistakeably belong to the arborescent sections of the semi-tropical ferns. In these examples their internal organisation is too characteristic to leave much room for error respecting their primeval affinities, but there are many forms which leave abundant room for those differences of opinion respecting their true relationship that are so common in the writings of even our

most experienced observers. Under these circumstances I strongly object to the undue multiplication of generic and other names that are so common amongst us. Where we find considerable groups, the individuals composing which have certain very definite features existing throughout the entire group, as is the case, for instance, with that of the *Zygopterids*, it seems to me useful to give them a common name. But the cases are numerous in which this cannot be done. In such types each example would require a name of its own. This necessity would arise, partly from the imperfection of the fragments with which we have to deal, but also, in part, from the absence, in many such instances, of sufficiently individualised features to make their differences easy to define. In such cases as *Lyginodendron* and *Heterangium* these fundamental differences are important and easily defined; but in numerous other instances this is not the case. To these I have assigned, in my later *Memoirs*, the comprehensive term *Rachiopteris*, which binds together a number of examples of which the general organisation is certainly fern-like, but which signifies nothing more. As more definite groups can be formed out of this very varied and comprehensive cluster, such groups can be differently dealt with. With the working of this method we have a good illustration in one of the earliest plants that came into my hands, which I had described in Part VI. of my *Memoirs* under the name of *Edroxylon*, but to which I afterwards assigned the name of *Rachiopteris aspera*. In my Part IV., I had described a very distinct plant under its present name of *Lyginodendron Oldhamium*; but in Part VI. I expressed my strong conviction that the former plant would ultimately prove to be the petiole of the latter one. I never lost sight of this possibility, but I had to wait sixteen years before I obtained clear proof that my original surmise was absolutely correct. This determination was an important one, because

*Lyginodendron* was a plant with a magnificent zone of secondary exogenous wood, developed from a true cambium. But Dr. Scott and I have recently united with it a second form viz., the *Kaloxylon Hookeri*, which proves to be its root. No true fern previously discovered had exhibited such a cambium; but the *Lyginodendron Oldhamium* described now took its place, along with the *Calamites* and the *Lycopods*, in both of which important groups of *Cryptogams* the possession of an active cambium was the normal condition. This family of the *Lyginodendra* is the first that I propose to deal with in this part of the Index.

## FILICES.

### TYPE OF *LYGINODENDRON OLDHAMIUM*.

*Primary Branch prior to emergence through Cortex.*

*Earliest State. Transverse.*

No Medullary Cavity occupied by primary Wood.

R.—p. 92, Fig. 10, C.N. 1885A.

a. Tracheids of Primary Xylem.

b. Secondary Fascicular Xylem.

*Secondary State.*

R.—p. 92, Fig. 11, C.N. 1885H. Primary Xylem broken up into about five separate bundles, a', a'. See also C.N. 1138.

*Medullary Rays.*

R.—p. 92, Fig. 10, C.N. 1885A.

p. 92, Fig. 11, C.N. 1885H.

BRANCH EXTENDED BEYOND THE CORTEX OF THE PARENT STEM, AND INVESTED BY ITS OWN CORTEX.

R.—p. 93, Fig. 12, C.N. 1141. Medullary cavity further enlarged, and filled with medullary cells.

SECONDARY XYLEM.

R.—p. 92, Fig. 12, C.N. 1141. New Tracheæ to the periphery of each of the secondary Laminæ.

CORTEX—YOUNG.

R. 1141. Irregular Cambium at the innermost border of the Cortex.

CORTEX MORE MATURED.

Cambium not previously figured or described.

Innermost Cortex of C.N. 1141, 1193, 1194, and 1195.



CORTEX—MIDDLE.

R.—p. 90, Fig. 3c, C.N. 1138.

*Gum-Canals.*

R.—p. 90, Fig. 3b, C.N. 1138. Fig. 2A 2l.

CORTEX—EXTERNAL.

R.—p. 90, Fig. 3b, C.N. 1138.

*Fibrous Cortical Bands.*

*Transverse.*

R.—Figs. 4a and 5a, C.N. 1138. Figs. 1g and 3g'.

*Parenchymatous spaces.* Like R.—Fig 6f.

R.—p. 90, Figs. 1f and 3f. p. 91, Fig. 9hh' and f.

D.—p. 385, Fig. 10, C.N. 1113.

LONGITUDINAL, RADIAL, AND TANGENTIAL.

MEDULLA.

*Radial not Figured.*

See C.N. 1124 and 1082.

PRIMARY XYLEM.

Not distinguishable in long sections.

SECONDARY XYLEM.

*Tangential.*

D.—p. 385, Fig. 15k'k". See 1184.

TRACHEIDS OF PRIMARY AND SECONDARY XYLEM.

*Tangential Surfaces.*

D.—p. 380, Fig. 4, C.N. 1167.

*Radial Surfaces.*

D.—Fig. 9, C.N. 1183.

MEDULLARY RAYS.

*Tangential Sections.*

D.—p. 382, Fig. 8. See C.N. 1184.

*Radial Section.*

D.—Fig. 9, C.N. 1183.

CORTEX.

*Tangential of outer layer.*

D.—p. 385, Fig. 13, C.N. 1146.

R.—p. 90, Fig. 6, C.N. 1144.

*Peripheral Surface.*

See C.N. 1205 and 1207a.

*Cast of the above Surface.*

See C.N. 1206 and 1207.

PERIPHERAL APPENDAGES TO THE CORTEX.

R.—p. 91, Fig. 6h, h', h", C.N. 1144.

Fig. 8hh. Fig. 9hh'.

## LARGE CORTICAL TRACHEÆAL BUNDLES.

Varied conditions.\*

*Transverse.*Double type, *without secondary xylem.*

D.—p. 383, Fig. 17z, C.N. 1187.

Single type, *without secondary xylem.*

C.N. 1111.

Double type, *with secondary xylem.*One *with* and one *without secondary xylem.*

C.N. 1114.

Both Bundles, *with secondary xylem.*

D.—p. 387, Figs. 19, 20, C.N. 1134.

Single type, *with secondary xylem.*

See C.N. 1113.

## FERN PETIOLES, PRIMARILY RACHIOPTERIS ASPERA. WILL.

Of these I have sections from the broad bases, and from the ultimate twigs bearing the leaflets.

## BASE OF PETIOLE.

*Transverse.*

F.—p. 679, Fig. 1, C.N. 117. p. 682, Fig. 6, C.N. 118.

## SMALLER BRANCHES.

R.—p. 90, Fig 2, C N. 1854.

*Transverse.*

R.—p. 90, Fig. 1, C.N. 117. p. 91, Fig. 7, C.N. 1191.

F.—p. 682, Fig. 7. See C.N. 119\*, p. 682, Figs. 8 and 9, See C.N. 135, 1191. ♀

*Longitudinal.*

F.—p. 680, Fig. 2. See C.N. 124, 125, 127'. R.—p. 91, Fig. 8, C.N. 1856. See also 1855.

---

\* The number, arrangements, and forms of these are most easily studied in fairly perfect transverse sections of the stems, in which we find seven modifications. I have noted their characteristic features in seventeen such sections. They are most commonly grouped in pairs, located in the innermost cortical zone, each pair being in more or less close contact. The above seventeen sections have furnished twenty-eight examples in this condition. Sometimes we find solitary bundles, but such are otherwise undistinguishable from the twin ones. Of these I have recorded nine in the seventeen sections. We occasionally find a pair, one of which is in its normal condition, but where the peripheral surface of the second one is furnished with a variable number of secondary tracheæal laminae arranged in a fan-shaped manner. In three instances I have found both the bundles so furnished, and in three examples I have seen the solitary bundles similarly supplied on their external borders. In nearly all the cases where the bundle of primary tracheæ has a zone of secondary xylem on its peripheral side I have found a zone of cambium investing its outer surface. In one instance the bundle must have been imbedded in the cambium, because the secondary laminae radiate equally in a star-like manner from the entire periphery of the primary bundle. We occasionally find the pair being pushed outwards through the outer cortex of the stem or branch. In such instances the two bundles are always imbedded in a considerable development of cortical parenchyma, which is obviously about to escape as a branch from the periphery of the parent stem. But this is a point that will require a more detailed examination later on—a point that involves the entire question of the position of the Filicinæ during the Carboniferous age.

TRACHEIDS.

F.—Fig. 3, A, B, C. C.N. 128.

CORTEX.

p. 681, Fig. 5. See C.N. 149, 150, 151.

p. 682, Fig. 11, C.N. 142.

p. 681, Fig. 4, 5 (erroneously numbered Fig. 3 in the text).

TERMINAL TWIGS AND FOLIAGE OF PETIOLE.

F.—p. 683, Fig. 13.\* See a similar example in C.N. 143.

STRUCTURE OF INDIVIDUAL LEAVES.

See 193a and 1856.

DOUBLE BUNDLES ESCAPING THROUGH THE CORTEX, TO BECOME VASCULAR BUNDLES OF LEAF PETIOLES (RACHIOPTERIS ASPERA) OF LYGINODENDRON OLDHAMIUM.

R.—p. 89, Fig. 1, k. C.N. 1880. See also C.N. 1890 and 1150.

C.N. 1980 (another section).

C.N. 1981. A second section from the specimen 1980, but in which the pair of bundles and their appropriate investments have become almost completely detached from the parent *Lyginodendron*, and become an ordinary example of the *Rachiopteris aspera*. Thus, since the latter condition is a true fern frond, we now know that at least one of the carboniferous ferns possessed a true cambium by which was developed an elaborate zone of exogenous secondary xylem possessing conspicuous medullary rays.

*HETERANGIUM GRIEVII. Will.*

This plant approximates so closely to *Lyginodendron* in most features of its structure as to convince me that they belong to the same division of the fern family. Their distinctions are chiefly seen in the arrangements of the tissues which occupy the interior of the medullary cavity. Instead of finding the primary xylem, in its young state, entirely filling that cavity, and ultimately breaking up into about five very distinct masses, each of which adheres closely to the inner margin of the secondary xylem, as is the case with *Lyginodendron*, that central area of the stem is partially filled with very numerous small bundles of primary xylem, the intervals between which are firmly occupied by a network of what apparently ought to have been true medullary cells; notwithstanding the peculiarity of their position and arrangement, I venture, as I did in the

---

\* The original of this figure is in the Cabinet of my old friend, Mr. J. Butterworth, of Shaw, near Oldham.

very similar condition seen in the axial centre of *Lepidodendron selaginoides*, to apply to these cells the term medullary.

#### PRIMARY XYLEM AND MEDULLARY PARENCHYMA.

##### *Transverse.*

D.—p. 395, Fig. 30a, C.N. 1250.

p. 395, Fig. 31b and c, C.N. 1250.

##### *Longitudinal.*

D.—p. 395, Figs. 32 and 33b and c, C.N. 1266, 1268, 1270, 1276, 1278, 1284.

#### STRUCTURE OF TRACHEIDS.

D.—p. 395, Fig. 24, C.N. any of the above longitudinal sections.

#### SECONDARY XYLEM.

##### *Transverse.*

D.—p. 395, Fig. 30d, C.N. 1250.

##### *Longitudinal.*

D.—p. 395, Fig. 32d, d. C.N. 1250.

#### MEDULLARY RAYS.

##### *Tangential.*

D.—p. 396, Fig. 33a, C.N. 1265, Fig. 33, C.N. 1268.

##### *Radial.*

p. 396, Fig. 33f, C.N. 1268.

#### CORTEX—INNERMOST ZONE.

##### *Transverse.*

D.—p. 396, Fig. 30g and 35g, C.N. 1250.

##### *Longitudinal.*

D.—p. 397, Fig. 32g, C.N. 1270.

#### MIDDLE ZONE.

##### *Transverse.*

D.—p. 397, Fig. 30h, C.N. 1250. Fig. 35h".

##### *Longitudinal.*

D.—p. 397, Fig. 45, C.N. 1270. Fig. 32hh, C.N. 1278.

#### LARGE VASCULAR BUNDLES IN INNER AND MIDDLE CORTEX.

##### *Transverse.*

D.—p. 399, Figs. 30 and 35 m.m'. Figs. 37 to 44, C.N. 1240 to 1247-

##### *Longitudinal.*

D.—p. 399, Fig. 32m, C.N. 1284♀. See also 1248 (barred).

#### ORIGIN OF BUNDLES.

D.—p. 401, Fig. 30m"', C.N. 1250.

#### ANOMALOUS BUNDLE WITH SHORT TRACHEIDS.

D.—p. 401, Fig. 36, C.N. 1260.

OUTERMOST CORTEX.

*Transverse.*

D.—p. 398, Fig. 35. See C.N. 1244k."

*Longitudinal.*

D. p. 398, Fig. 32k", C.N. 1278k".

YOUNG TWIGS.

*Transverse.*

D.—p. 402, Fig. 46, C.N. 1244, 1280, 1283, 1295, and 1296.

*Longitudinal.*

D.—p. 402, Fig. 47. See numerous sections in C.N. 1287 and in C.N. 1296<sup>†</sup>.

*HETERANGIUM TILIÆOIDES.* Will.

This plant approaches so closely to *H. Grievii*, not only in the general type of its structure, but even in many of the details of its organisation, that I see no reasonable grounds for placing them in separate typical groups. At the same time, as I have shown in my *Memoir XIX.*, notwithstanding its typical resemblances to *H. Grievii*, and though the differences between the two are those of detail, and not of type, the beautiful structures of *H. Tiliæoides* show a distinct advance to a higher order of exogenous organisation than we find in the former plant. So far as its central vasculo-medullary axis is concerned, it is a true *Heterangium* in every detail characteristic of the genus; but when we turn to the aspects of its secondary xylem, and its investments of highly developed Phloem, we discover the differences between the two forms. This is important. *Lyginodendron*, now clearly proved to be a true fern, carries inseparably along with it *Heterangium Grievii*, and in like manner the latter cannot be disjoined from *H. Tiliæoides*. If all this is incontrovertible, it results that the fern must now be regarded, not only as ranking amongst the exogenous *Cryptogams*, but as taking a high position in that well-characterised group.

STEM OR BRANCH.

*Transverse.*

N.—p. 289, Fig. 1, C.N. 1302.

## MEDULLARY AXIS AND ITS PRIMARY XYLEM.

N.—p. 289, Fig. 1A. Fig. 3a Medullary Cells, 3b Primary Xylem.  
p. 289, Fig. 1h. Fig. 2B, C.N. 1303.

N.—p. 289, Fig. 5, b.c and b.c.,\* C.N. 1303.

N.—p. 389, Fig. 4d secondary vascular laminae; 4h secondary medullary rays, C.N. 1303.

N.—p. 389, Fig. 4g,g extensions of primary medullary rays. See also Fig. 1g, C.N. 1302.

*Longitudinal.**Radial.*

N.—p. 291, Fig. 9, including secondary xylem and cortex, C.N. 1628.

p. 291, Fig. 9A, vasculo-medullary axis. *a*, medullary cells; *b*, tracheids of primary xylem.

p. 291, Fig. 9B; *d,d*, secondary xylem; *h,h*, medullary rays.

## PHLOEM ZONE C.

*Transverse.*

N.—p. 290, Fig. 1C, C.N. 1302.

p. 290, Fig. 1k, defined Phloems of separate Vascular bundles.  
C.N. 1302. See also Fig. 5k, C.N. 1303, and 4k.

## PHLOEM RAYS.

N.—p. 290, Fig. 1n, C.N. 1302; p. 290, Fig. 2n, C.N. 1303; p. 292, Fig. 13n, C.N. 1619; p. 290, Fig. 4n,n, C.N. 1303.

## CORTEX, INNER.

*Transverse.*

N.—p. 290, Fig. 1p, C.N. 1302.

p. 290, Fig. 2p, C.N. 1303; p. 290, Fig. 3p, C.N. 301.

## PHLOEM ZONE AND INNER CORTEX.

*Longitudinal. Radial.*

## SECONDARY MEDULLARY RAYS.

N.—p. 291, Fig. 9hh, C.N. 1628.

## PHLOEM RAYS.

*Transverse.*

N.—p. 291, Fig 4n,n.

*Longitudinal.*

N.—p. 291. Fig. 9cn, C.N. 1628.

## PHLOEM TUBES—SIEVE TUBES OR CAMBIFORM CELLS.

N.—p. 291, Fig. 9l, C.N. 1628.

## PHLOEM.

*Tangential.*

N.—p. 291, Fig. 1ol (Sieve tubes?), C.N. 1622.

---

\* Two bundles pushed outwards from their normal position as a regular portion of the secondary xylem cylinder.

INNER CORTEX.

*Radial.*

N.—p. 291, Fig. 9D, C.N. 1622.

OUTER CORTEX.

*Transverse.*

N.—p. 290, 291, Fig. 6r, C.N. 1303. Fig 1r, C.N. 1302.

*Radial.*

N.—p. 292, Fig. 11, C.N. 1304.

MEDULLARY CYLINDER.

*Transverse.*

P.—p. 156, Fig. 2b, C.N. 1833 ; p. 156, Fig. 1bb\*.

AERIAL ROOTLET BUNDLES.

*Transverse.*

P.—p. 157, Figs 1 and 3. Seen in most of the transverse sections.

EPIDERMAL HAIRS.

P.—p. 158 and the Longitudinal section, C.N. 1857.

TRACHEIDS OF MEDULLARY CYLINDER.

All barred. See 1842 x and 1843 x .

CORTEX.

Mixture of Parenchyma, C.N. 1840, and Prosenchyma, C.N. 1841.

ZYGOPTERIS.—Petioles only preserved.

ZYGOPTERIS CORDA.

During the last twenty years numerous organisms have been described under the name of *Zygopteris*. Most of these have been fern-like petioles. In 1889, Professor Stenzel, of Breslau, published a *Memoir* "On the Stem of a Carboniferous Plant," to which he gave the name of *Zygopteris scandens*, but which he placed in a secondary division of the *Zygopteroid* group (*Ankyopteris*). I had previously (in 1888), figured one under my type-name of *Rachiopteris Grayii*. Dr. Stenzel having sent me a copy of his *Memoirs*, I arrived at the conclusion that our two plants were identical. In order to obtain his opinion on the matter, I sent him one of my sections of *Rachiopteris Grayii* for comparison with his

---

\* There is still some obscurity in the relations of 1b' to 2b'. Is the latter a modified condition of the former, or is it identical with the axil-sprosse of Stenzel, Fig. 3b, the *Zygopteroid* petiole being wanting?

own plant. Owing to some differences in the dimensions of the two forms, he was unable to conclude that they were identical. The petioles of both examples being alike furnished with the characteristic *Zygopteroid* vascular bundle, I shall, for the present, continue to follow his example, and recognise my form under the more definite type-name of *Zygopteris*. The first specimen of this type which came into my hands I published in *Memoir* VI., under Corda's name of *Anachoropteris Decaisnii*, its peculiar *Zygopteroid* petiolar bundle not having been discovered at that time. This, however, has now been done; and since has given the name of *Zygopteris* to a characteristic example of this group of stems. I have elected to follow his example, and to apply the same type-name to the entire *Zygopteroid* group.

*RACHIOPTERIS. Will.*

*Z. BIBRACTIENSIS. Renault.*

*Transverse.*

F.—p. 697, Fig. 49, C.N. 195. For more perfect specimens see C.N. 196A and 197.

*Longitudinal.*

F. p. 697, Fig. 50, C.N. 108. See also C.N. 1815.

ISOLATED CLUSTERS OF SEMI-SCLEROUS CELLS, APPARENTLY CORRESPONDING TO FIG. 32H OF HETERANGIUM GRIEVLII.

N.—p. 291, Fig. 11,t,t,t. C.N. 1304.

VASCULAR BUNDLES, PASSING OUTWARDS THROUGH THE CORTEX, RESEMBLING THOSE OF D, FIG. 17Z, IN LYGINODENDRON, AND D, FIG. 35M'M, IN HETERANGIUM GRIEVLII.

N.—p. 290. Fig. 1u',u'. C.N. 1302. Fig. 7u,u, C.N. 1623. Fig. 8u,u, 1302.

SPECIAL BUNDLES, RESEMBLING D, FIG. 7, AND X, FIG. 24, IN LYGINODENDRON, AND D, FIG. 36, IN HETERANGIUM GRIEVLII.

N.—p. 292, Fig. 12w, C.N., 1622, and Fig. 13eee'. Fig. 13,e,e,w, C.N. 1619.

STRUCTURE OF TRACHEIDS.

N.—Barred, p. 293, Fig. 14, C.N. 1301.

Reticulate, p. 291, Fig. 9, 1628.

Bordered Pits, p. 293, Fig. 16, C.N. 1621,  $\frac{1}{\text{T}}$  and  $\frac{1}{\text{O}}$ .



ZYGOPTERIS GRAYII.\*

MEDULLA.

*Transverse.*

P.—p. 156, Fig. 1a, C.N. 1832. The medullary cells have disappeared.  
See also 264a. Medullary cells preserved in C.N. 1919D.

ZYGOPTERIS LACATTII. Renault.

*Transverse.*

F.—p. 696, Fig. 45, C.N. 201. p. 296, Fig. 47, C.N. 214.

*Longitudinal.*

F.—p. 696, Fig. 43, C.N. 212. Tracheids barred.

For secondary branches passing off from the primary axis consult  
C.N. 1808 to 1812; for barred and reticulate tracheids in the  
same bundle see C.N. 1812.

ZYGOPTERIS DI-UPSILON. Will.

*Transverse.*

K.—p. 537, Fig. 90, C.N. 216.

*Longitudinal.*

K.—p. 538, Fig. 91, C.N. 218.

For longitudinal sections of Fig. 90c see C.N. 220c.

Ditto Fig. 90f see C.N. 219f.

Ditto Fig. 90h see C.N. 218, 220, and 221h.

RACHIOPTERIS. Will.

This group comprehends a number of apparent fern structures, from amongst which no very definite subdivisions can be established worthy of having assigned to them distinctive names. They will, therefore, retain their present provisional name of *Rachiopteris*, until more can be ascertained respecting their several mutual relations.

RACHIOPTERIS INSIGNIS. Will.

A rare type, the Tracheids of which are very liable to be filled with Tylosa.

*Transverse.*

K.—p. 506, Fig. 19, C.N. 265. Fig. 20, the central vascular bundle of  
Fig. 19 further enlarged.

p. 506, Fig. 22. Tracheids devoid of Tylose, C.N. 267.

*Longitudinal.*

K.—p. 506, Fig. 21, C.N. 265. See also C.N. 266B.

*Transverse.*

p. 507, Fig. 23. Section of the bundle of a secondary branch  
issuing through the Cortex of Fig. 21.

---

\* In memory of my old and distinguished friend, Asa Gray.

*RACHIOPTERIS ROBUSTA.* Will.

A rare form, of which I have only two sections taken from the same specimen.

K.—p. 505, Fig. 23A, C.N. 269–270.

*RACHIOPTERIS INÆQUALIS.* Will.

Accidentally called *R. irregularis* in the text of Q.

Q.—p. 206, Fig. 28. See C.N. 265b, 320 & 1814.

*RACHIOPTERIS CYLINDRICA.* Will.*Transverse.*

I.—p. 350, Fig. 80, C.N. 179.

p. 351, Fig. 87, C.N. 179; p. 351, Fig. 88, C.N. 179.

*Longitudinal.*

p. 351, Fig. 86, C.N. 182.

*RACHIOPTERIS ROTUNDATA.*

*Anachoroptis rotundata* Corda.

I.—p. 350, Fig. 79, C.N. 271. See also 272 and 273.

*RACHIOPTERIS GONIOCENTRA.* Will.

C.N. 274 and 275. Not yet figured.

*RACHIOPTERIS DUPLEX.*

A very distinct form, only obtained hitherto from the Burntisland or Petticur district.

## VASCULAR AXIS.

*Transverse.*

F.—p. 688, Fig. 28, C.N. 223, → a,a. Fig. 30, C.N. 237. Fig. 35, a,a'. See C.N. 227.

*Longitudinal.*

p. 688, Fig. 29, C.N. 234. See also 232 and 244.

## SECONDARY PETIOLES.

*Transverse.*

See Figs. 35A to 35K.

P.—p. 693, Fig. 39, C.N. 240. Fig. 41. Figs. 35D, 35E.

*Longitudinal.*

See C.N. 239, 242, and 243. Tracheids reticulated.

CORTEX.

*Transverse.*

Most of the specimens.

*Longitudinal.*

See C.N. 229 to 236.

The specimens from which Figs. 35A to 35K were drawn are in the Cabinet of Wm. Carruthers, Esq., of the Natural History Museum, Cromwell Road, London.

ZYGOPTEROID PETIOLE, VASCULAR BUNDLE.

P.—p. 157, Fig. 3f, C.N. 1831.\*

AXIL-SPROSSE OF STENZEL.†

P.—p. 156, Fig. 3e and Fig. 5a, C.N. 1831.

*RACHIOPTERIS OLDHAMIUM.*

*Transverse.*

*Matured.*

F.—p. 685, Fig. 20. See C.N. 160. Very young twigs.

p. 685, Figs. 22, 23, 24. See 160 and 167,

p. 685, Fig. 21, C.N. 160. Rather more advanced.

p. 686, Fig. 25A, see C.N. 150, 'g' C.N. 156, with a triangular bundle.

p. 686, Fig. 26. With two secondary bundles becoming detached from the primary one.

*Longitudinal.*

p. 686, Fig. 27, C.N. 162. A bifurcating young branch.

p. 685, Fig. 25, C.N. 161.

*RACHIOPTERIS CORRUGATA. Will.*

STEM OR RHIZOME.

*Transverse.*

H.—p. 214, Figs 2 to 12,‡ C.N. 245 to 255 inclusive.

MEDULLA.

*Transverse.*

H.—p. 214, Fig. 13a, with its several narrow outward extensions, a', a', C.N. 247; also Fig. 4b, C.N. 247.

*Longitudinal.*

p. 214, Fig. 14a, C.N. 260.

---

\* To place this petiole in its normal position relative to the axil cylinders, Figs. 1b and 2b, we must recognise in Fig. 2b' the representative of Fig. 3e—i.e., the "axil-sprosse" of Stenzel—the petiole, Fig. 3, not being preserved in Fig. 2.

† Its normal position in the stem being external to the Zygopteris Petiole. See C.N. 1831

‡ A series of eleven sections from the same stem, cut in the order of their consecutive numbers, and showing the variations in the primary tracheal cylinder, *b*, in the larger petiolar bundles, *c*, in the smaller branch bundles, *c, d, l*, as well as the peripheral outline of the cortex, *f, f'*, where the petiolar bundle, *c*, is gradually becoming the centre of a true petiole in Fig. 10, c.

## VASCULAR CYLINDER.

*Transverse.*

p. 214, Fig. 4b, C.N. 247. Fig. 13b, C.N. 259.

p. 215, Fig. 19b,b,b'. Centre of the cylinder of Fig. 6 enlarged.

*Longitudinal.*

p. 214b,b, C.N. 260. Fig. 21b, C.N. 257, more tangential.

## PHLOEM?

p. 214, Fig. 14g, C.N. 260. Fig. 21g, C.N. 257.

## LARGER SECONDARY PETIOLAR BUNDLES.

*Transverse.*

p. 215, Fig. 20b' (from section Fig. 7, further enlarged), C.N. 250.

p. 215, Fig. 18 (axial within its petiole), C.N. 261.

p. 215, Fig. 5c, C.N. 248. Fig. 6c, C.N. 249.

p. 215, Fig. 4c, C.N. 247.

From Figs. 2 to 10 the bundle c is developed, and ultimately enclosed within the separating petiole, Fig. 10g, C.N. 249.\*

## SMALLER SECONDARY BUNDLES (LEAF TRACES?)

p. 216, Figs. 3d and 4dd, C.N. 247.

Fig. 20d, C.N. 250, further enlarged.

## TRACHEIDS WITH TYLOSE.

p. 214, Fig. 15, C.N. 261. Fig. 16, 256.

## CORTEX.

*Transverse.*

H.—All the transverse sections.

*Longitudinal.*

Fig. 18f, C.N. 261.

*External Surface.*

H.—p. 213, Fig. 1. At 263 is a fragment of the investing matrix from the original specimen, and also an impression of it in wax.

*RACHIOPTERIS HIRSUTA, Will.*

P.—p. 160, Fig. 9 (through an irregularly branching fragment), C.N. 1847.

*Transverse.*

p. 161, Fig. 11; a, central axial bundle; g, branches from a; f, sections of epidermal hairs, C.N. 1845.

p. 161, Fig. 10; clusters of the hairs from g,g. of Fig. 9, C.N. 1847.

p. 161, Fig. 12 vascular axis, c, giving off three vascular bundles, d,d,d', of doubtful destination, possibly to rootlets, C.N. 1846.

p. 161, Figs. 13 and 14. Possibly sections of two rootlets, like Fig. 12d,d.

p. 161, Fig. 15. Almost certainly a section of a younger rootlet.

\* In Fig. 7 we find a second larger petiolar bundle developing at *b*, and giving off a smaller leaf trace (?) at *d*. At Fig. 8 the petiolar bundle has become free at *b* and the smaller one at *l*. We also find at *f* the outlines of a new petiole becoming obvious.

*RACHIOPTERIS RAMOSA*,\* Will.

STEM.

*Transverse.*

S.—p. 261, Fig. 19a, C.N. 1851A.

*Longitudinal.*

p. 261, Fig. 20, C.N. 1918B.

BRANCHES.

*Transverse.*

S.—p. 262, Fig. 21. A primary branch, C.N. 1851.

p. 262, Figs. 22 and 23. Secondary branches, C.N. 1851.

p. 262, Fig. 24. A yet more distal twig, C.N. 1851.

TRACHEIDS.

Fig. 25. Reticulate Tracheids from the axial bundle *a* of Fig. 20, C.N. 1918B.

EPIDERMAL HAIRS.

p. 262, Fig. 26. Portion of Cortex, with its peculiar hairs *in situ*, C.N. 1918D.

p. 262, Fig. 27. Two isolated epidermal hairs, C.N. 1918C.

p. 262, Fig. 28. The base of one of the secondary vascular bundles, Fig. 19c, where the tracheids are suddenly deflected laterally from the central bundle, *a*.

*PSARONIUS RENAULTII*. Will.

PART OF STEM.

*Transverse.*

M.—p. 464, Fig. 16. Part of the Cortex of an arborescent stem, enclosing one perfect vascular bundle, *a*, and a portion of second, *a'*, C.N. 309.

G.—p. 12, Figs. 22\* and 22\*\*. Original in Mr. Carruthers' Cabinet.

p. 11, Fig. 18. Cluster of ærial roots in the Cortex, C.N. 311.

p. 11, Fig. 19. Vascular bundles at d,d, Cortex, i, with ærial roots at C.C. See C.N. 312, 313, and 314.

p. 11, Fig. 20. Cortex with ærial roots, C.N.

p. 11, Fig. 21. Part of Fig. 18, further enlarged.

SPORANGIA OF FERNS.†

H.—p. 220, Fig. 27, C.N. 1459.

p. 220, Fig. 28, C.N. 1460. p. 220, Fig. 29, C.N. 1460. 

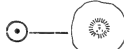
p. 220, Fig. 30, C.N. 1471. 

\* It is possible that this plant may only be a variety of *Rachiopteris hirsuta*.

† When Memoir VIII. was published I was under the impression that each of these sporangia possessed an annulus. This is probably true of the rare form, Fig. 25, though I have no certain evidence that this was the case; but it is not true of the more common Yorkshire and Lancashire form, Figs. 27—30.

## SPORANGIA; AN APPARENTLY DISTINCT FORM.

p. 220, like Fig. 25, C.N. 1879. Cells of Sporangial wall much smaller. See C.N. 319a and 318.

Several sporangia like Fig. 25, C.N. 318.

Several sporangia, one evidently pendunculate, C.N.319.

*MYELOPTERIS. Renault. MYELOXYLON. Brongniart.*

Few fossil plants have been the subjects of more controversy than those figured in my *Memoir* under the first of the above names. The *Medullosa* of Cotta, the *Palmacites* of Corda, the *Stenzelia* of Gœppert, to the two names at the head of this paragraph, including the new *Rachiopteris Williamsoni* of Seward,—this group has not only received a confusing number of names, but the question of its position in the vegetable kingdom has led to its being tossed to and fro between the Cycads and the Ferns. In my *Memoir* referred to above, I described a series of specimens in my Cabinet, numbered from C.N. 276 to 305. M. Renault at the same time was, unknown to me, studying similar objects; we finally and independently arrived at the same conclusion, viz., that they were Carboniferous representations of the living group of Marattiaceous ferns. At a later period my old pupil, Mr. Seward, undertook a re-examination of my specimens, and found amongst them what appeared to be examples of two different forms. One of these he regarded as being true *Myeloxylons*, and the others as belonging to a more ordinary type of ferns, which he determined to publish under the name of *Rachiopteris Williamsoni*. The first result was the publication, in the *Annals of Botany*, for March, 1893, of a memoir on the *Myeloxylons*, which he regarded as constituting an independent type of plants intermediate between the Ferns and the Cycads, but apparently having a nearer relation to the latter than to the former family.

Under these circumstances, in reply to my request, he

has kindly given me the following outline of his views on the structure of his *R. Williamsoni* :—

“The structure of the petiole of *Rachiopteris Williamsoni* resembles in many respects that of *Myeloxylon* ; but the vascular bundles show certain well-marked peculiarities, and a divergence from those of Brongniart’s genus *Myeloxylon*, which seems to justify a specific separation. *Myeloxylon* agrees with Cycads rather than with Ferns. *Racheopteris Williamsoni* approaches much more closely to the typical fern-bundle, and is, therefore, regarded as a fern petiole.

“The two plants agree in (1) the nature of the hypodermal tissue, consisting of alternating bands of sclerenchyma and parenchyma ; (2) in the possession of larger gum (?) canals in the ground tissue. Their most important differences may be briefly stated as follows :—

“In *Myeloxylon* the bundles of vascular tissue are collateral, and the protoxylem is placed next to the phloem ; in *Rachiopteris Williamsoni* the bundles are concentric, and they agree in position with that of the ferns. In *Myeloxylon* there are no parenchymatous elements associated with the xylem vessels. In *R. Williamsoni* there is much xylem parenchyma ; another marked difference consists in the occurrence of regularly disposed canals surrounding the xylem in *R. Williamsoni*. These do not occur in *Myeloxylon*. The specimens which have been examined of the new species show these canals in various stages of development. They are quite distinct from the larger canals scattered in the ground tissue, and are regularly arranged towards the periphery of the phloem in each bundle.”

Some of the differences here recorded are easily seen. Others are not so clear in my specimens. Of course the most conspicuous one is the existence of collateral bundles in one case, and of circumferential ones in the other. But even here we must remember that we have collateral bundles in ferns (e.g., *Osmunda*), and De Bary has found circumferential ones in a Cycad. Hence, the question arises, did these differences always possess the same distinctive value that they may do now ? Schenck and Solms-Laubach

differ even now on this point. Hence, I cannot conclude that these distinctive features settle the question of the boundary lines between the Ferns and the Cycads. For the present, however, I have arranged my specimens in Seward's two groups, to facilitate their further investigation and study.

*MYELOPTERIS.*

PRIMARY PETIOLL.

*Transverse.*

G.—p. 3, Fig. 1, C.N. 276. See also C.N. 286, 286b, 286c. 305  
very large Petiole from Autun.

SECONDARY DIVISIONS OF PETIOLE.

p. 3, Figs. 3, 4, and 4\*. See 286a and others from C.N. 286 to 292.

*Longitudinal.*

*Primary.*

p. 3, Fig. 2, C.N. 298—303.

*Secondary.*

p. 3, Figs. 5 and 6. See C.N. 286, 293 and 4.

*Oblique.*

G.—See C.N. 286e.

SUB-EPIDERMAL SCLERENCHYMA.

*Transverse.*

C.N. 276. See also 305.

*Longitudinal.*

C.N. 276f, ♂.

*RACHIOPTERIS WILLIAMSONI.* Seward.

*Transverse.*

C.N. 277 to 282. Five transverse sections from the same entire Petiole.

*Longitudinal.*

C.N. 283, 284, 285. Three sections from the same Petiole as the transverse ones.

*Memoir VII.* Figure 7 is a transverse section of a vascular bundle of this plant.



Notes on *Wulfenia Carinthiaca*, Jacquin. By James  
Cosmo Melvill, M.A., F.L.S.

(Received December 12th, 1893.)

or many years this beautiful member of the natural order *Scrophularineæ* has maintained its prestige as the most local, perhaps, of European plants, if we except the *Dioscorea pyrenaica*, Bubani, from the P. de Gavarni, Eastern Pyrenees.

To those who have read what may be called the 'Pioneer Guide-book' to the Dolomites and Tyrol, the name of *Wulfenia* will be familiar, for Mr. G. C. Churchill, who collaborated with the late Mr. Gilbert in the production of this work,\* based upon three successive visits in 1861-63, to what was till then a 'terra incognita' almost, to the tourist or botanist, made the search after this plant one of the chief aims of his journeys. Twice were the travellers disappointed at finding it past flower, but the third time they were fully rewarded. The following notes, written by my brother, the Rev. A. H. Melvill, and my sister, Miss Evelyn Melvill, who spent four months in the Tyrol this summer (1893), may be interesting :

We left Lienz on Tuesday, July 25, by an early train for Greifenburg. With very great difficulty we succeeded in procuring a carriage to drive us to Hermagor, a distance of about 15 miles. Arrived there we had also great trouble in finding rooms, as the Post Hotel was full. At length we found some in the small hotel opposite the Post, where we were made exceedingly comfortable. We made enquiries first thing about the *Wulfenia*, and found the landlady knew all about it, in fact had dried specimens, and showed us in the garden some living plants, but out of flower. She said she would engage a guide for us, and afterwards, while we were talking to him and making arrangements for an early start the next morning, a German gentleman came

---

\* *The Dolomite Mountains*, by Josiah Gilbert and F. C. Churchill, F.G.S. London: Longmans. 1864.

up who knew all about the subject, the best localities, &c., and said he thought we might find some late specimens, but that the bulk of it was over, the proper flowering time being May or June, and not July and August, as stated in most botanical works, and that this year was an earlier one than usual, owing to the small amount of snow which had fallen in the winter. He advised us to try the Watschiger Alp, and not the Kuhweger, though the latter is easiest to get at. So we settled to start at 5 the next morning, driving as far as possible, and engaged Josef Gobendorfer as guide.

July 26. A perfect summer's day. At 5.10 we were off in an einspanner, and in about three-quarters of an hour arrived at the village of Watschig. Here we alighted, and, crossing the Gail by a wooden bridge, found ourselves in shady pinewoods, which we traversed for a mile or so till we came to a brawling stream, where the ascent soon began in earnest. We had to mount along the bed of this stream, crossing it many times. Then up a very steep and rocky mule track till we came to a small lake with wonderfully transparent water (the Watschigersee). It was full of pine trunks. Then up again till we came in sight of the chalets on the Alps, and our guide pointed out to us the first plants of the *Wulfenia*, but, alas! utterly over. We began to doubt whether we should find any flower at all. However, we found some other plants quite new to us and very pretty, especially one white flower of the order *Caryophyllea*. Having rested awhile, we mounted yet higher up the slopes of the Gartnerkofel, and now we came upon the *Wulfenia* in extraordinary abundance, covering in places every atom of the ground, young plants growing almost on the top of old ones, and seeming to struggle with them for existence; but nearly all were out of flower, the tall seed-spikes rising in every direction, and showing what a splendid display there must have been earlier in the year. Our guide told us the whole mountain side here appeared dark blue; but higher up than this (we were about 6,000 feet) the plant is entirely absent. The whole appearance of the Alp is like one vast garden; lower down, where the *Wulfenia* does not occur, there are great beds of Alpine roses, and by the stream many saxifrages and other flowers. It is appropriately called "The Garden Mountain." The Alpine roses were in places covered with curious galls, looking like small peaches, and some bright scarlet, like tomatoes, of great size. To return to the *Wulfenia*—after a long search we found about a dozen specimens, some of them with flowers still perfect, and some good enough for a sketch in our *Nat. Hist. Journal*.

*Wulfenia* may be thus characterized.

A glabrous herb, with perennial stalk. Leaves nearly all radical, stalked, crenulate. Flowers in a one-sided cyme, blue, calyx 5-partite, sepals narrow. Corolla with cylindrical tube, narrowed. Lobes four, the upper bifid, the lower ones either undivided or crenate. Stamens two, exserted; inserted between the upper lobes; anther cells divergent,

but confluent at the tips. Stigma capitate. Capsule acute, septiferous ; scepæ leafless.

Fl. end of May and June.

The species are as follow :

*W. Carinthiaca*, Jacq. Carinthian Alps.

*W. orientalis*, Boissier. Seleucia, N. Syria, (Aucher Eloy), Antioch (Montbret.).

Cf. Boissier, *Fl. Orientalis*, IV., pp. 430, 431.

*W. Amherstiana*, Bentham, *Scroph. Ind.*, 46.

Western Himalaya, nr. Kumaon, and Afghanistan.

*W.<sup>?</sup>reniformis*, Douglas ?

It is uncertain whether this belongs to the genus.

*Wulfenia Carinthiaca*, Jacquin (*Miscellanea* 2, p. 62, t. 8).

Leaves oblong, crenated, somewhat narrowed at the base, radical ; tube of the corolla swollen above the base, segments of the limb rounded, upper bifid, lower crenate, lateral often undivided, blue, whitish within : 1½ to 2 ft.

Syn. :—*Pædarota Wulfenia*, Lamk.

Introduced to England, 1817.

Named by Jacquin in honour of the Rev. François Xavier Wulfen, author of the *Plantæ rariores Carinthiaccæ*.

The localities affected by *Wulfenia* are most circumscribed :

Nyman, *Conspectus Floræ Europææ*, p. 543, cites

“Carinthia meridionalis (Kühweger Alp et secus Grisebachium in 1872 detecta a cl. Schenk in aliâ alpe huic proxima) Carniola (Auernick Kofel el Ball 1865). Friul (pr. Ponteba sec Pir. Syll.) alp.”

To which in the *Supplement* to the above, 1889, p. 235, he adds :

“In Carinthiâ loca speciei natalia sunt (ex Pucher ; Gailthal, circà montem Gartner Kofel in Watschiger-Kühweger-, Granitzer-, Zichel-, et Auernigalm : Hab. inter rupes ; in pascuis et silvaticis apertis, 1500-1900 metr. s.m., loca italica,

ut in Conspectu indicantur, duo, sec. Caruel (1886) unum solum sistunt ; Friul, et quidem in limite extremo bor.- or alpium Italicarum in latere meridionali montis Auernick Kogel, orientem versus à monte Nassfeld (1500 metr.) qui versus boreali-occidentem à pago Pontebba (Pontafel) situs est." Comment. 193.

In my Herbarium are specimens collected by Mr. Chas. Packe from the ' Gartner Kofel, suprà Hermagor Carinthiæ,' July 9, 1870. Alpen de Tröpolaz by Dr. Lagger. " Vallich, Carinthia, with no collector's name, from the Boswell (Syme) collection ; and the specimens collected by Rev. A. H. Melvill and Miss E. H. Melvill at the Gartner Kofel, July 27th, 1893.

These places, Gartner Kogel, Kühweger Alp, Vallich Tröpolaz Alp, Granitzer Alp, Friul, Pontebba, are all within a very appreciable distance of each other, say 10 square miles, and may almost be called at most two localities, both in the same neighbourhood. The Italian boundary line is not far S. of Hermagor, and Friul and Pontebba are just below it.

Bentham and Hooker, *Genera Plantarum*, Vol. II., p. 913, divide the large order *Scrophularineæ* into three series,

*Pseudosolaneæ*,

*Antirrhinidæ*,

*Rhinanthideæ*,

these being again subdivided into twelve tribes. The tenth in sequence, and the first of the series *Rhinanthideæ*, is that of the *Digitaleæ*, thus well characterized, the following being a translation from the Latin :—

RHINANTHIDEÆ. Leaves various. Inflorescence simply centripetal. Lower lip or lateral lobes of the corolla external in the bud. Stamens very rarely more than four, often only two.

Tribus X. *Digitaleæ*.

Corolla usually little if at all bilabiate, the lobes all plane, the lateral or one of them external. Anther-cells contiguous at the apex and often confluent. Herbs, or shrubs, not parasitic.

The following genera belong to this section :\*

|                                |     |               |                                               |
|--------------------------------|-----|---------------|-----------------------------------------------|
| <i>Sibthorpia</i> , Linn.      | - - | 6 sp.         | W. Europe, Africa, India, S. America.         |
| <i>Hemiphragma</i> , Wallich   | -   | 1 sp.         | Himalayas.                                    |
| <i>Scoparia</i> , L.           | - - | 1 sp.         | Tropics of both hemispheres.                  |
| <i>Capraria</i> , L.           | - - | 4 sp.         | W. Indies and S. America, Mexico and Florida. |
| <i>Camptoloma</i> , Bentham    | -   | 1 sp.         | W. Africa.                                    |
| <i>Digitalis</i> , L.          | - - | 18 sp.        | Europe, Asia.                                 |
| <i>Isoplexis</i> , Lindley     | - - | 2 sp.         | Madeira, Canary Isles.                        |
| <i>Erinus</i> , L.             | - - | 1 sp.         | Europe.                                       |
| <i>Campylanthus</i> , Roth.    | -   | 4 sp.         | Canaries, Cape de Verde, and Arabia.          |
| <i>Lafuentea</i> , Lag.        | - - | 1 sp.         | Spain.                                        |
| <i>Ourisia</i> , Comm.         | - - | 18 sp.        | N. Zealand, Andes of S. A.                    |
| <i>Picrorhiza</i> , Royle      | - - | 1 sp.         | Himalayas.                                    |
| <i>Synthyris</i> , Bentham     | -   | 6 sp.         | N. America.                                   |
| <i>Wulfenia</i> , Jacquin      | - - | 4 sp.         | Carinthia, W. Asia, Himalayas.                |
| † <i>Calorhabdos</i> , Bentham | -   | 3 sp.         | Himalayas, Japan, China.                      |
| <i>Pædarota</i> , L.           | - - | 2 sp.         | Europe.                                       |
| <i>Veronica</i> , L.           | -   | circa 200 sp. | Europe, Asia, America, Australia, N. Zealand. |
| <i>Aragoa</i> , H. B. and K.   | -   | 3 sp.         | S. America.                                   |

This list of Durand's entirely agrees with the arrangement in Bentham and Hooker excepting in the removal of the Chinese and Japanese genus of 2 species, *Rehmannia*, Lib. and Fisch., to the Cyrtandrous section of the order

\* *Index Gen. Phanerogam*, Durand, p. 296, being a revision to date (1889) of Benth. and Hook. *Gen. Plantarum*, as approved by Sir J. D. Hooker.

† Forbes and Hemsley in the Enumeration of Chinese Plants, *Journ. Lin. Soc.*, Vol. XXVI., p. 195, enumerate 5 sp. of *Calorhabdos*, but they allude to the one called ovary being more Gesneraceous than Scrophularious.

*Gesnerææ*, from which it had, with apparent reason, been removed (*Gen. Plant*, II., p. 960), as agreeing with *Ourisia* in several important details.

I have brought here to exhibit with the specimens of *Wulfenia* from my herbarium, examples of all these genera excepting two, viz.: *Camptoloma*, of which only one specimen has ever been gathered, and *Calorhabdos*, which, as being so near an ally of *Wulfenia*, I am sorry to have been unable to procure. As a substitute, however, I exhibit a plate of two species of the genus.

We here in Lancashire can boast of, perhaps, the handsomest of the whole series, as it is the type, viz., *Digitalis purpurea*, to the Purple Foxglove, being one of the most plentiful plants in the neighbourhood, often, as at Prestwich, monopolizing everything else, self-sown, in a shrubbery, or open space, and ornamenting many a woodside in the summer. Many species of *Veronica* likewise abound around us.

The genera have been placed with much care and circumspection by the learned authors of *Gen. Plantarum*: and there can be no doubt but that the nearest allies of *Wulfenia* are

|                       |   |   |           |
|-----------------------|---|---|-----------|
| <i>Ourisia</i> ,      | - | - | Stamens 4 |
| <i>Picrorhiza</i> ,   | - | - | „ 4       |
| <i>Synthyris</i> ,    | - | - | „ 2       |
| <i>Calorhabdos</i> ,  | - | - | „ 2       |
| and <i>Pædarota</i> , | - | - | „ 4       |

this last showing a decided link between this plant, and the spicate *Veronicæ* (*Pseudolysimachia*, Bentham, *Leptandra*, North), the first mostly natives of Europe and Asia, the latter of North America.

*Pædarota*, Linn, in its two species *P. Ageria*, L. and *Bonarota*, L., with the hybrid between the two, named by Huter *P. Churchillii* in honour of Mr. G. C.

Churchill, of Clifton, Bristol, the well-known European botanist, shows much affinity, as already said, with *Wulfenia*, especially in the species *Bonarota*, the flowers of which are purple, while those of *Ageria* are yellow.

But the nearest approach to the genus in formation of its corolla and other particulars is undoubtedly the N. American genus *Synthyris*,\* Bentham. Here the flowers are small, purplish for the most part, in a simple spike, the stamens (two exserted) are situate close to the sinuses of the corolla, which is 4 cleft, somewhat irregular. Style filiform, with capitate stigma. The main difference between the two genera is that the anther-cells are in *Synthyris* not confluent. *Wulfenia* is, however, a much more showy plant.

The genus *Gymnandra*, Pallas, a small Oriental and Arctic group, now placed in the *N. O. Selagineæ*, and allied to *Globularia*, L., has several points in common both with *Pædarota*, *Synthyris*, and *Wulfenia*; indeed by George Don, in *Dichlamydeous Plants*, Vol. IV., p. 581, it was placed in *Scrophularineæ*, next to *Wulfenia*. Here the corolla is bilabiate, upper lip either emarginate or bifid, lower one 2-4 cleft. Stamens 2. The order *Selagineæ* has many points in common with *Scrophularineæ*; all (nearly) the species of both orders turn black in drying, the *Selagineæ* are, however, as a rule of a different habit; many assume an eriliform appearance, and they differ mainly from the *Scrophularineæ* by the cells of the ovary being 1-2 ovulate, and even Bentham and Hooker confess this character is not always to be relied upon.

Lastly, the genus *Ourisia*, Comm., native of New Zealand, Tasmania, and the Andes of S. America, may be compared with *Wulfenia*, as possessing many attributes in

---

\* In May, 1872, I had the privilege of spending a short time with the late Dr. Asa Gray, at Cambridge, Mass., U.S.A., and, showing me *Synthyris Houghtoniana* growing in the Botanical Garden, he pointed out its characteristics and touched upon its affinity to *Wulfenia*, *Digitalis*, and *Veronica*, and, if I remember aright, mentioned that he considered the genus one of the most interesting in North America.

common, but the stamens are 4, and not exserted. The habit of such species as the New Zealand *O. macrophylla* would be, I should imagine, the same.

In a Flora like the European, in which are found very large assemblages of certain genera like *Hieracium*, *Centaurea*, *Linaria*, *Ranunculus*, *Saxifraga*, and *Carex*, it is all the more interesting to note a few isolated types which have just put in an appearance, as it were, and only just impinge upon the Flora.

How the *Wulfenia* first became established near Hermagor we cannot divine, but it is evidently of Eastern origin. The *Dioscorea*, to which we have already alluded, is even more interesting as being a member of a subtropical genus, not otherwise known in Europe except in one Pyrenæan station, and the *Ramondia Pyrenaica*, Lam., with its two allies *Haberlea Rhodopensis*, Frivaldsky, and *Jankœa Heldreichii*, Boissier, of the natural order *Cyrtandraceæ*, a section of *Gesneraceæ*, otherwise tropical or subtropical, are parallel instances of localization. These three are found, one in the E. Pyrenees only, the next in the Balkan Mountains, Thrace, and the third, and rarest, on the Thessalian Olympus.

Other instances might be adduced: all one can do is to note the facts, and attempt to draw conclusions. The question of the geographical distribution of plants is most fascinating, and some of the data are quite without the possibility of solution. Our own islands afford plenty of material; many of our rarest plants are confined to one spot, and two, *Spirantheus Romanzoffiana* (*gemmaipara*, Linn.) and *Eriocaulon septangulare*, L., natives also of the Neartic region, are unknown in Europe excepting in Ireland, and as regards the latter the I. of Skye, in addition.

---







[*Microscopical and Natural History Section.*]

Ordinary Meeting, December 18th, 1893.

Mr. R. E. CUNLIFFE, President of the Section, in the Chair.

Mr. J. F. ALLEN and Mr. J. WATSON were elected Associates of the Section.

The PRESIDENT moved:—"That the Section notes with great regret the loss to science caused by the death of John Tyndall, LL.D., M.D., D.C.L., Ph.D., F.R.S., F.C.S."

Dr. BROADBENT gave a microscopical demonstration of Infusoria found in water obtained from manure heaps.

Mr. J. C. MELVILL, F.L.S., exhibited a specimen of *Bulinus (Porphyrobaphe) labeo* (Broderip) from Peru, a very scarce land mollusk, conspicuous for the swollen, almost diseased appearance of the marvellously incrassate and reflected outer lip, which has deep pittings and crenulations all over its swollen and tumid surface, not dissimilar to the appearance of cooled lava.

Mr. Melvill also exhibited eleven of the thirteen or fourteen known *Rhopalocera* of New Zealand, which country is the poorest in the world for its size for not only these insects, but also those of most other orders, although the bulk of the Coleoptera and Hymenoptera which do occur are peculiar, and show the extreme antiquity of this land, formerly, according to Wallace, a large continent embracing the Macquaries, Lord Howe Island, The Auckland and Campbell Isles, and Norfolk Island. That it has been dissociated from Australia from the earliest times, is evident by the differences in the Flora as well as in the Fauna.

“The Butterflies” remarked Mr. Melvill, “are as follow :

## DANAIDÆ.

*Hamadryas Zoilus* (Fabr.).

Also occurs in Australia.

*Danais Eriippus* (Cramer).

A North American species, very nearly cosmopolitan.

## NYMPHALIDÆ.

*Pyrameis Itea* (Fabr.).

Also in Australia.

*P. Gonerilla* (Fabr.).

Endemic.

A handsome species.

*P. Cardui* (L.).

Quite cosmopolitan. Known in England as the ‘Painted Lady.’ A small variety—*Kershawii*— occurs in Australia.

*Diadema (vel Hypolimnas) Bolina* (Fabr.) ubiquitous in E. tropics.

## SATYRIDÆ.

*Argyrophenga Antipodum* (Doubleday).

Endemic.

A most beautiful species, with conspicuous longitudinal silver markings on the under side. The only species of the Genus.

*Erebia Merula* (Hewn.).

= *Pluto* (Fereday).

The specimen exhibited was given me by Mr. J. Davies Enys, the discoverer. Endemic, and rare.

## LYCÆNIDÆ.

*Lycæna Oxleyi* (Felder).

A pretty little 'Blue.' Endemic. The specimens shown came from the collection of the Rev. R. P. Murray.

*Ensyii* (Butler).

I have not seen this lately discovered species.

*Chrysophanus Salustius* (Fabr.).

Endemic. Very like a European species.

*C. Boldenarum* (White).

A small species. Copper, shot with purple reflection.  
Endemic.

*Feredayi* (Bates).

I do not know this endemic species."

---

## Ordinary Meeting, January 2nd, 1894.

[Adjourned from December 26th, 1893, by resolution of the Council.]

Mr. JAMES COSMO MELVILL, M.A., F.L.S., Vice-President,  
in the Chair.

The thanks of the members were voted to the donors of the books upon the table.

Reference was made to the untimely death of Professor A. MILNES MARSHALL, F.R.S., who was elected a member of the Society in 1879, the members present testifying in a very special way to their sense of personal loss.

Reference was also made to the completion of the Manchester Ship Canal, and the following resolution, moved by the Ven. Archdeacon ANSON, and seconded by Dr. BOTTOMLEY, was adopted :—“That this meeting congratulates the Directors and Shareholders of the Manchester Ship Canal Company on the completion and opening of the Canal for traffic, and expresses a sanguine hope that it will conduce to augment the prosperity of the city and district.”

A discussion on the appearance of gulls on the Canal at Throstle Nest, and elsewhere, ensued.

Mr. CHARLES BAILEY pointed out that in the records of the Society there were accounts of the appearance of similar gulls at Peel Park, and elsewhere, many years ago.

Mr. F. NICHOLSON, F.Z.S., said that the birds now seen are young birds of the black-headed marsh-gull species, which breeds at Winmarleigh. The peculiarity of the phenomenon is that the birds seem to be settling in the

vicinity of Old Trafford, whereas the birds formerly seen at Peel Park were only passing visitors.

Mr. CHARLES BAILEY exhibited a map of Palestine, constructed in relief on the scale of  $\frac{1}{168960}$  ( $\frac{3}{8}$  of a mile to to 1 inch), recently issued by the Palestine Exploration Fund, and read the following note on the exhibit :—

“ Having acquired a copy of a raised map of Palestine for use in Sunday School teaching, I have thought it would interest the members of our Society to exhibit so fine a piece of workmanship. It represents the results, physically expressed, of some of the labours of the Palestine Exploration Fund, which was established 1st October, 1865. The actual survey of the country began on the 21st November, 1871, by the measurement of a base line on the plain between er Ramleh and Ludd, not far from the track of the modern railway line. At that date the only accurate map of the country consisted of its coast-line, as laid down on the Admiralty charts. The features of the interior were only known on broad lines ; perhaps the best map of the period was that by Lieutenant C. W. M. van de Welde, on the scale of  $\frac{1}{315000}$ , published in 1858, now exhibited to the members, and by comparing any portion of it with the  $\frac{1}{168960}$  scale map of the Palestine Exploration Fund, we are better able to judge of the relative accuracy and amount of the topographical details. When that map was issued we did not know the exact altitude of Jerusalem above the Mediterranean, nor the depressions of the Dead Sea and the Sea of Galilee below it ; and in spite of the patient labours of Robinson and others, it was remarkable how few Biblical sites had been determined. Now, all this has been completely changed by the publications of the Fund, and the whole has been accomplished for a sum which has not yet reached £100,000, voluntarily subscribed by the public.

“ The large map of Palestine on the one-inch scale =  $\frac{1}{63360}$ , published by the Fund in the year 1880 in 26 sheets, is the

basis upon which the present model of the country has been constructed ; but instead of adhering to the one-inch scale, which would have made it unwieldy, its scale is  $\frac{1}{108960}$ , say  $\frac{3}{8}$  of an inch to the mile horizontally, and about one inch and a quarter to the mile vertically. The horizontal scale corresponds with the map on the same scale issued by the Fund, and the sheets of that map form an admirable index to the physical features expressed on the model. Sheets of the  $\frac{3}{8}$  inch map, illustrating the drainage divisions and mountain ranges, as well as those of the  $\frac{3}{8}$  inch map printed to show the Biblical sites, are alongside the model. Some of the sheets of the one-inch scale are also exhibited for comparison.

“The present relief map has been built up by Mr. George Armstrong, the Assistant Secretary of the Palestine Exploration Fund, who took part in the primary triangulation of the country, and who has been engaged in the laborious duties of the survey continuously from 1871. None but an enthusiast, who had himself been over the ground, could have constructed such a map, or expended the patience required in raising it layer by layer, from the deepest depression at the northern end of the Dead Sea, to the highest elevation of the Lebanon range. The leisure of no less than seven years has been spent in its construction.

“The copy of the relief map now exhibited to the members has been purposely kept bare of names so as not to obscure the topographical details. The physical aspects of the country are, to a certain extent, indicated by the colouring adopted ; the permanent waters by blue ; the forests, river margins, and cultivated lands by green, &c.

“By the aid of such a raised map the untravelled student may picture its scenery, understand the allusions to its topography ; and see where the roads of the country must run ; he can follow the tracks of rival armies



upon its battle fields, and apprehend better the conditions attaching to rival sites. Why should not the councils of our counties, cities, and boroughs, go to the comparatively small expense of reproducing from the Ordnance maps of Great Britain, similar relief maps of their immediate districts?

“In a country so interesting as Palestine to the student of physical geography, it would have been well to have shown on the raised map the sea-level in the gorge of the Jordan, from the point just below the exit of the river from the Baheiret el Hûleh (Waters of Merom) to the district south of the Dead Sea ; it would have shown how the aspect of the country would have been changed if it had been possible to have constructed a ‘Dead Sea Canal’ as a rival to the Suez Canal. It would also have been of interest to have shown the contour lines on such a map for every 1,000 feet of altitude.”

---

General Meeting, January 9th, 1894.

Professor ARTHUR SCHUSTER, Ph.D., F.R.S., F.R.A.S.,  
President, in the Chair.

Mr. J. H. BECKETT, of Miles Platting, and Mr. MARSHALL  
STEVENS, of Urmston, were elected ordinary members.

---

Ordinary Meeting, January 9th, 1894.

Professor ARTHUR SCHUSTER, Ph.D., F.R.S., F.R.A.S.,  
President, in the Chair.

The thanks of the members were voted to the donors of the books upon the table.

Reference was made to the death of Professor Hertz, of Bonn, at the age of 37. He was elected an honorary member of the Society in 1889, and attained distinction by his experimental verifications of Clerk Maxwell's theory that electrical oscillations are propagated through space with the velocity of light.

A discussion ensued on the recent variations of temperature, in which Dr. SCHUSTER, Dr. REYNOLDS, Mr. RUPERT SWINDELLS, and others took part.

Reference was made to the recent kitchen boiler explosions, and Professor OSBORNE REYNOLDS remarked that any corporation or local board which allows a plumber

to place, in an outer wall, pipes, the freezing of which may endanger lives, takes a course which is well nigh criminal.

Professor SCHUSTER read the following note on "An Oak Tree struck by Lightning" :—

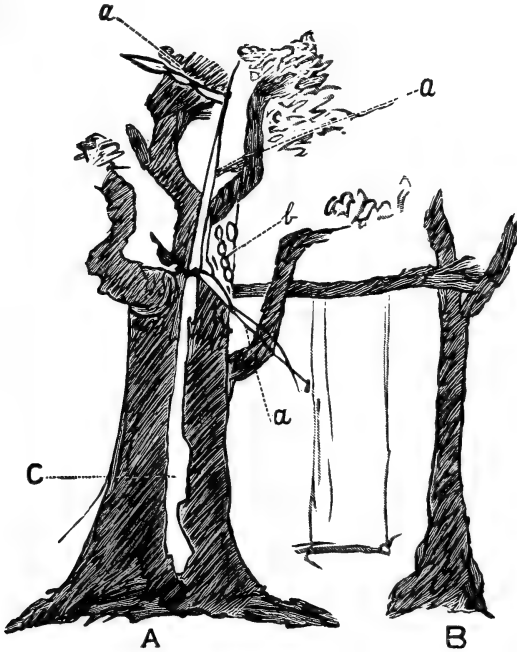

"The following instance of a flash of lightning striking an oak tree on July 2nd, 1893, seems to be worthy of notice, as the tree stood in a hollow, and seemed to be sufficiently protected by the higher ground surrounding it.

"The tree A is one of a row of five or six oaks, and stands at the western end, the only tree further out being the small tree B which stands under A, that is, the foliage of the higher parts of the tree A which is not shown in the figure, completely covers B, which consists of little else but the stem. The other trees of the row are nearly of the same height, but A is decidedly less high than some of the others. The trees all stand at the lower end of a narrow valley, the

brook which runs through it leading into the Esk, near Ruswarp (1½ miles from Whitby). The ground rises close behind the tree to a height of about 110 feet above the level of the roots of the tree, which is about 40 feet high. On the other side of the valley the ground also rises rapidly to about the same height. The figure shows at C the space left free by a band of the bark stripped off to a height of about 14 feet, which is the height at which the stem first divides. An iron chain (*b*) is attached to one of the branches, and supports a beam from which a swing is suspended. Large splinters of the bark were thrown across the whole breadth of the valley, *i.e.* about 60 feet, while others marked *a* in the figure remained partly attached to the tree.”

---

[*Microscopical and Natural History Section.*]

Ordinary Meeting, January 15th, 1894.

Mr. R. E. CUNLIFFE, President of the Section, in the Chair.

The PRESIDENT drew attention to the recent death of Professor A. MILNES MARSHALL, and gave expression to the loss the Section had suffered thereby.

Mr. BAILEY exhibited a relief map of the valley of the Jordan and the Phœnician coast, based on the survey of the Palestine Exploration Fund.

Mr. H. C. CHADWICK read a paper on “A Study of the *Siphonophora*,” illustrated by means of the lantern and the microscope.

---

Ordinary Meeting, January 23rd, 1894.

Professor ARTHUR SCHUSTER, Ph.D., F.R.S., F.R.A.S.,  
President, in the Chair.

The thanks of the members were voted to the donors of the books upon the table.

Mr. HENRY WILDE, F.R.S., gave an experimental demonstration of the uses to which the Corporation supply of electric light and power may be put in philosophical research, and read the following note:—

“The installation of a supply of electricity in the rooms of the Society for lighting and other purposes, affords a fitting opportunity for making a few observations on the history of the dynamo-electric machine which I thought might be of some interest to the members.

“In the early part of the year 1866, I invited the Council of this Society to a private demonstration of the powers of a new generator of electricity, founded on my discovery of the principle, *that quantities of magnetism and electricity indefinitely small could induce quantities of these forces indefinitely great.* The new generator in which this principle was embodied is now called a dynamo-electric machine, or, as contracted by commercial usage, a ‘Dynamo.’

“Among those who responded to my invitation were Dr. Joule, Dr. Angus Smith, Prof. Clifton, Mr. Baxendell, and Mr. Binney. The luminous and calorific effects produced by the new dynamo-electric machine far surpassed any that had previously been witnessed in this country or abroad, but neither myself nor those present at the demonstration had any idea that electricity generated by the new method would, within the next twenty-eight years, be

supplied, like gas and water, by the Corporation of the City of Manchester.

“ Since the time when my first dynamo-electric machine was invented, many important improvements have been made, by myself and others, in the details of these machines to render them more efficient for the several purposes to which they have been applied. The first of such improvements was the device of substituting the residual permanent magnetism of iron for the magnetism of steel, as the initial stage of the indefinite increase of the magnetism of the electro-magnets. This happy device, which was hit upon by several inventors almost simultaneously, consisted simply in coupling up, by means of a short piece of wire, the armature and electro-magnetic circuits of a dynamo-electric machine, and involved no change either in the principle or in the construction of my original machine. The residual permanent magnetism of the large electro-magnet of this machine, as I have already pointed out, was enormously greater than that of the small steel magnets of the magneto-electric machine which originally excited it. The principle, therefore, of magnetic accumulation as first enunciated and demonstrated by me is common to every class of dynamo-electric machines. I should not have considered it necessary to make these observations before members of the Society, to whom the principles of these machines are well known, were it not that writers of text-books who are unacquainted with the extent of my researches, persist in setting up the utilization of the residual magnetism of electro-magnets as a principle in electrical science, than which nothing can be more erroneous.

“ The utilization of the residual magnetism of electro-magnets was soon followed by the improvements of Pacinotti and others in the construction and winding of the armatures ; the object of which was the production of continuous currents, as distinguished from the alternating wave

current previously evolved from magneto-electric and dynamo-electric machines. The sub-division of the iron of the armatures was a marked advance over earlier forms, as indicated by the great increase of electrical duty obtained, which is now, in the best practice, as high as 95 per cent of the mechanical power absorbed by the dynamo-electric machine. Various subsidiary improvements have also been made by several inventors in the winding of the electro-magnets of dynamo-electric machines, having for their object the automatic regulation of the amount of electricity generated to the amount of electric power required in the external circuit.

“I may also be permitted to mention in connection with these improvements my discovery of the synchronous rotations of the armatures of a number of dynamo-electric machines, by which their united power can be obtained without the use of mechanical gearing. This discovery, which was first announced at a meeting of this Society in the year 1868, is largely utilised in the United States of America, and is now in course of further development at the electro-mechanical power station below the Falls of Niagara. The principle has also been applied with some success at general lighting stations in this country and on the Continent. I am also pleased to note the fact that, the largest and most powerful dynamo-electric machines at the Corporation Electric Supply Station, although associated with other names, are, in their main features, built according to the designs of my original generator of electricity as described and figured in the *Philosophical Transactions of the Royal Society* for the year 1867.

“Since the expiration of the controlling patents for dynamo-electric machines, the manufacture of these machines has become a considerable industry, in which a large amount of capital is invested, affording employment to many thousands of persons.

“I shall leave to others the task of dealing with the history of the several important applications of dynamo-electric machines for the production of electric light, electrolytic processes, the transmission of motive power and other purposes.

“Of far greater interest than the substitution of electric light for gas light in the Society’s rooms are the facilities now afforded by the Corporation supply of electricity for increasing the light of natural knowledge by the illustration of communications made to the Society in various branches of experimental philosophy. Of the many uses and manifestations of the electric supply may be enumerated :—

1. The arc and incandescent lights.
2. Heating wires and other calorific phenomena.
3. Energizing induction coils and producing electric oscillations.
4. Charging powerful electro-magnets.
5. The action of magnetism on gases.
6. Diamagnetic polarity and magnecrystallic force.
7. Reproducing the phenomena of terrestrial magnetism.
8. Demonstrations in spectrum analysis.
9. Conversion of electricity into mechanical work.
10. Electrolysis of chemical compounds.
11. Reduction of refractory substances in the electric furnace.
12. The artificial formation of minerals.
13. Demonstrations in biology and physiology.
14. Lantern projection for microscopic and other objects.

“Some of the more prominent of these applications of the electric supply I shall be able to demonstrate before the Society, and I have a confident hope that, with the increased facilities afforded to the members for prosecuting philosophical research, the Society will be as successful in extend-



ing the boundaries of human knowledge in the future as it has been in the past."

In answer to one of the members, Mr. WILDE said that the electricity from the Corporation mains could be rendered suitable by means of an induction coil for the ozonizing of oxygen for bleaching purposes.

Special interest was manifested by the members in Mr. Wilde's exhibition of a new line which he has observed in the spectrum of thallium, and in experiments with his "Magnetarium," to illustrate his theory of terrestrial magnetism.

---

Ordinary Meeting, February 6th, 1894.

Professor ARTHUR SCHUSTER, PH.D., F.R.S., F.R.A.S.,  
President, in the Chair.

The thanks of the members were voted to the donors of the books upon the table.

Mr. ROBERT MOND, M.A., F.C.S., of Winnington Hall, near Northwich, was elected an ordinary member of the Society.

Messrs. H. GRIMSHAW and R. E. CUNLIFFE were appointed auditors of the accounts for the current year.

Professor SMITHELLS, of the Yorkshire College, read a paper on "Flame and Flame Spectra," and showed a series of experiments. After separating the inner and outer cones of a coal gas flame, he showed that lithium burnt in the inner cone and copper oxide or chloride in the outer cone. The paper contributed considerably to the question of the temperature of flame and the causes of its luminosity.

Professor DIXON, Dr. BAILEY, Dr. BOTTOMLEY, Mr. HARTOG, Mr. JONES, and Dr. SCHUSTER joined in a long discussion on the interpretations of Professor SMITHELL'S experiments.

---

[*Microscopical and Natural History Section.*]

Ordinary Meeting, February 12th, 1894.

Mr. R. E. CUNLIFFE, President of the Section, in the Chair.

Mr. ROGERS exhibited specimens of Egyptian cloth from the Fayoum, twelve hundred years old.

Mr. BAILEY drew attention to the weaving and the pattern, and suggested that it could only have been produced by means of a loom constructed on the Jacquard principle.

Mr. ROGERS also exhibited specimens of cotton silicate.

Dr. BROADBENT exhibited large specimens of cloth prepared from the bark of trees, decorated with geometric coloured patterns by the natives of the Samoa islands.

Mr. HYDE exhibited several cockroaches found near the Ship Canal at Ellesmere Port, supposed to have been conveyed from the United States in cargo.

---

Ordinary Meeting, February 20th, 1894.

Professor ARTHUR SCHUSTER, Ph.D., F.R.S., F.R.A.S.,  
President, in the Chair.

The thanks of the members were voted to the donors of the books upon the table.

Mr. W. E. HOYLE, M.A., exhibited the following shells, recently acquired by the Manchester Museum :—

(1) *Bathybembix argenteonitens*, from Japan. A characteristic deep-sea form, with delicate sculpture and pale iridescent colouration.

(2) *Columbarium pagoda*. A rare marine shell from Japan.

(3) *Columbarium distaphanotis*. A beautiful shell, of which the type-specimen from an unknown locality is unique. This example is from the Cholmondeley collection.

(4) *Opisthostoma mirabile*. A land shell from Borneo, in which, after a certain number of spiral turns, the shell bends upwards and the mouth comes to lie close to the apex.

(5) *Palaina Quadrasi*. An exquisitely sculptured operculate land shell from Manila, in which the first whorls form a right-handed and the last a left-handed spiral.

Professor SCHUSTER exhibited an apparatus in use at Owens College for testing clinical thermometers, and read the following note :—

“The Owens College has, during the last few years, undertaken the testing of clinical thermometers for medical men and others. It is the object of this note to describe the apparatus by means of which a number of these thermo-

meters can be conveniently tested at the same time. The apparatus consists essentially of two cylindrical vessels, one being placed inside the other. Both are filled with water. The thermometers are placed in a carrier inside the inner vessel. The water in the outer vessel is maintained at any desired temperature by an electric current passing through a platinum wire in the water. The water in the inner vessel is kept stirred by means of a revolving screw turned by an electric motor.

“The details of the different parts are shewn in (Figs. 1 to 3). Fig. 1 shews the carrier made of brass which holds

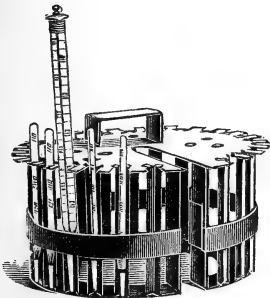

Fig. 1.

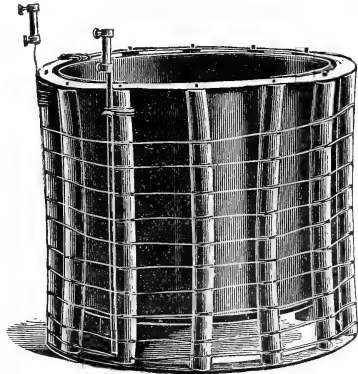

Fig. 2.

the thermometers. They are all kept in place by an india-rubber band pressing them against strips of brass bent so as to form a triangular groove. Fig. 2 shews the inner vessel round which a framework is fixed, carrying platinum wire. This wire is insulated from the vessel by means of indiarubber tubing which is placed over the brass supports. Fig. 3 shews the whole apparatus when put together. The brass rod passing into the vessel carries a pulley at one end and a stirrer at the other.

“The thermometers are compared at three temperatures, viz.,  $98^{\circ}$ ,  $103^{\circ}$ ,  $108^{\circ}$ . The vessel, without the carrier, having

been filled with water at some temperature below  $98^{\circ}$ , a current is sent through the platinum wire of such strength

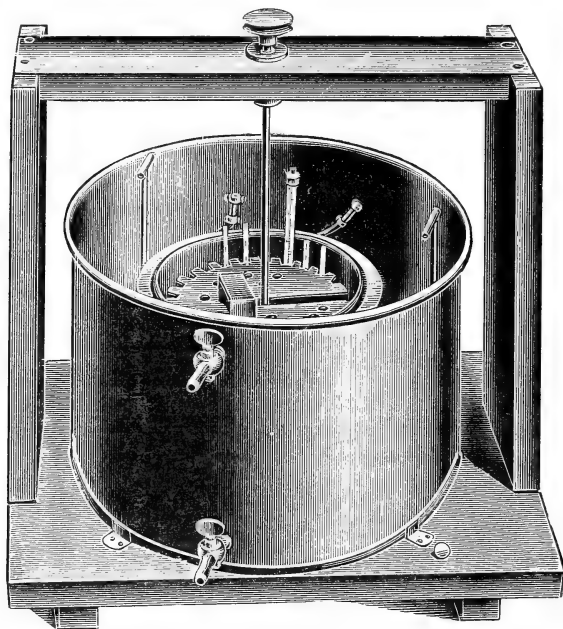

Fig. 3.

that the temperature ascends fairly rapidly to the required temperature, this current strength is then suddenly reduced to an amount previously determined and chosen so as to give a very slow and steady increase of temperature in the inner vessel. This rise should not exceed  $0^{\circ}\cdot1F.$  per minute, but it is essential that the temperature should continuously rise during the time of testing. As soon as the temperature has thus been regulated the carrier is plunged into the water. There is at first a cooling of the water due to the introduction of the carrier, but the rise in temperature soon begins to reassert itself. The cooling may, if desired, be almost reduced to nothing, by keeping the carrier before insertion into the testing vessel in water of about  $90^{\circ}$ , but there is no particular object in thus complicating the

method of procedure. The thermometers are kept in the water for a sufficient time to allow them to acquire its temperature. The standards are then read off, the carrier taken out, and the thermometers may be read off at leisure. The operation is repeated at the other temperatures for which the testing is to be carried out. As the ultimate standard of temperature, I use at the College a thermometer calibrated carefully at the Bureau International des Poids et Mesures at Paris. With proper precautions a temperature can be read off to three or four thousandth of a degree Centigrade. The College also possesses a thermometer divided into tenths of a degree Centigrade, compared with the Standards of the Technische Reichs Anstalt at Berlin. Both thermometers agree in their indications; they are made of glass, the composition of which in each case is definitely known, and their indications may without trouble be reduced to the air thermometer if desired.

“ I have, further, two thermometers compared at Kew. One of them (A) is divided into fifths of a degree Fahrenheit, and ranges from 90 to 115. Unfortunately it does not contain the freezing point, so that its changes cannot be followed. The other (B) is divided into tenths of degrees, and ranges from 90 to 110. Another part of the stem, separated from the rest by a bulb, is divided from 30° to 36°, so that its freezing point may be tested at any time. Finally, three clinical thermometers are also used for comparison, two of them having been standardised at Berlin and one at Kew.

“There is some doubt as to what the scale of temperature used at Kew really is; but the difference between the Kew temperatures, and the scale used on the continent, being probably about  $\frac{1}{20}$ th Fahrenheit near 100° F., is of no importance as regards clinical thermometers.

“The following comparison shows the agreement between

the different thermometers used as intermediate standards in an experiment carried on exactly as in an actual test :—

Kew, B reading, 101·4.

|                                             |     |     |     |     |     |       |
|---------------------------------------------|-----|-----|-----|-----|-----|-------|
| Clinical thermometer, found at Kew to be    |     |     |     |     |     |       |
| correct                                     | ... | ... | ... | ... | ... | 101·5 |
| (1) Clinical thermometer, found correct at  |     |     |     |     |     |       |
| Berlin                                      | ... | ... | ... | ... | ... | 101·4 |
| (2) Clinical thermometer, taking account of |     |     |     |     |     |       |
| corrections supplied by the Technische      |     |     |     |     |     |       |
| Reichs Anstalt                              | ... | ... | ... | ... | ... | 101·5 |

“The thermometers agree, therefore, to the limits of accuracy which can be attained.

“The College has tested about 300 thermometers in the last two years, and, as a general rule, it may be said that the corrections have been small; but it has occasionally happened that thermometers were found to be wrong by 0°·4 and 0°·5, which shows that no thermometer can be trusted to be sufficiently accurate which has not been compared with some standard.

“The result of testing also has shown that the more expensive kinds of thermometers have errors as great as the cheaper ones. The advantage which the more expensive thermometers claim, of being more rapid in their indications is often illusory. When a clinical thermometer is plunged into water of 100°F. it takes up the temperature almost immediately, and as to the time required when the thermometer is placed into the mouth of the patient it is the bad conductivity of the tissues of the mucous membrane which causes the lag in the rise. The skin or tongue is, under ordinary conditions, below the blood temperature, and is further chilled by the introduction of the cold thermometer. By reducing the mass of the thermometer the first chilling effect may be diminished and the instrument would indicate more quickly the correct blood temperature. But the gain is not as great as is generally supposed.”



Mr. THOMAS HICK, B.A., B.Sc., read a paper "On the primary structure of the stem of Calamites."

A discussion ensued, in which Professor WEISS and Mr. CHARLES BAILEY took part, the latter commenting on the rapid advances which are being made in the knowledge of fossil botany, which threaten, in his opinion, to make it necessary to revise all the classificatory work which has previously been done.

---

General Meeting, March 6th, 1894.

Professor ARTHUR SCHUSTER, PH.D., F.R.S., F.R.A.S.,  
President, in the Chair.

Professor A. S. DELÉPINE and Dr. G. H. BROADBENT  
were elected ordinary members of the Society.

---

Ordinary Meeting, March 6th, 1894.

Professor ARTHUR SCHUSTER, Ph.D., F.R.S., F.R.A.S.,  
President in the Chair.

The thanks of the members were voted to the donors of the books upon the table.

Reference was made to a recent display of *Aurora Borealis* visible in Manchester.

Mr. W. E. HOYLE, M.A., gave a demonstration of the luminous organs of cuttle fish, exhibiting sections with the aid of the lantern and under the microscope.

A conversation on the causes and purposes of apparent self-luminosity in the eyes of carnivorous animals ensued.

---

Ordinary Meeting, March 20th, 1894.

EDWARD SCHUNCK, PH.D., F.R.S., F.C.S., Vice-President,  
in the Chair.

The thanks of the members were voted to the donors of the books upon the table.

A discussion on meteorites took place.

Mr. JULIUS FRITH read a paper "On an analysis of the Electro - Motive Force and Current Curves of a Wilde alternator under various conditions." The object of the experiments described was to determine how far the behaviour of an alternator containing iron in the armature agrees with that of the theoretical alternator without iron. It was stated, as an approximate result, that the agreement was fairly good.

---

[*Microscopical and Natural History Section.*]

Ordinary Meeting. March 12th, 1894.

Mr. CHARLES BAILEY, F.L.S., in the Chair.

Professor F. E. WEISS, of Owens College, was elected a member of the section.

Mr. HYDE drew the attention of members to the flowers of the alder, poplar, willow, hazel, and birch, which are unusually large, numerous, and early this year.

Mr. ALLEN exhibited specimens of natural asbestos, and of silicate wool, produced by steam blown through slag when in a molten condition.

Mr. BROADBENT exhibited additional specimens of gnattoo (tapa,) prepared from the bark tissue of trees by the natives of the Samoa Islands.

---

Ordinary Meeting, April 3rd, 1894.

Professor ARTHUR SCHUSTER, Ph.D., F.R.S., F.R.A.S.,  
President, in the Chair.

The thanks of the members were voted to the donors of the books upon the table.

Professor OSBORNE REYNOLDS read the following note  
"On the Aurora Seen at Fallowfield on March 30th, 1894."

"At 10.20 p.m. on March the 30th I observed, from the Ladybarn Road, immediately in front of my house, which runs east and west, that there was an unusual amount of light, for the time of year, all over the sky on the northern side of the zenith, from east to west. At first it was only the amount of diffused light on the northern side, as compared with the southern, that caught my attention. The sky was perfectly clear at the time, and the stars were bright over the south, while over the north only the larger stars were visible. There was no moon.

"It soon became evident to me that the light was that of the aurora; but at first it was only remarkable for the amount of diffused light, of a pale green for the most part, but passing into red towards the south. After observing it for some 15 minutes the appearance became much more remarkable. Streamers rose towards the zenith from all parts of the northern horizon with great rapidity and vanished again as quickly, and following these up to the zenith I saw what I have never seen before. The sky was in a state of fluttering light, wave following wave three or four a second, the waves moving in the direction of the streaks of light which suggested showers of luminous hail. The most remarkable thing was, however, that the appearance of

waves was owing to the fluctuation of light in set places—more or less a series of broad bands across the direction of motion of the waves. These broad bands of misty white, fluctuating light, with more or less well defined dark between, preserved a set shape. The light apparently ended in a very bright arc like a long bright cloud running in an irregular line east and west through the zenith. The line had a decided wriggle in it near the zenith, and on the north was a dark space with another bright band with a corresponding wriggle, so as to create the appearance of a dark river between two bright banks. This shape lasted some time, disappearing and reappearing with the light. Watching this phenomenon, and looking towards the zenith, it became clear that the waves of light were moving nearly vertically, a little towards the south, and that they only took effect over a portion of the sky. Thus the motion seemed to diminish as it neared the zenith, and in the bright arc, exactly as though there was an illuminated vertical hail storm. I watched it about half-an-hour, when the zenith effects seemed to me to be diminishing.”

Mr. GWYTHER gave an account of the appearance of the phenomenon at Buttermere, where it presented a somewhat different aspect. Mr. BROTHERS and Professor SCHUSTER also took part in the discussion.

Mr. HENRY WILDE, F.R.S., read a paper “On the Influence of the Configuration and Direction of Coast Lines upon the Rate and Range of the Secular Magnetic Declination.”

---



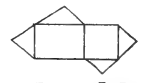
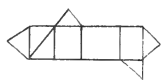
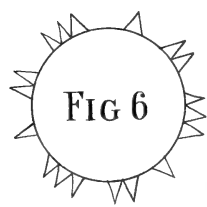
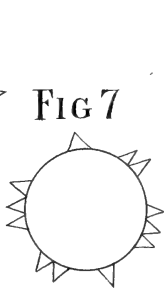
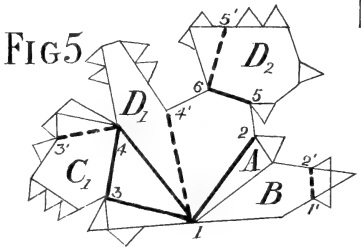
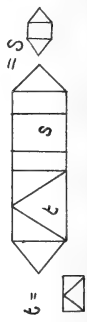
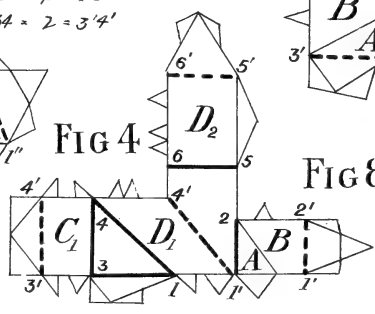
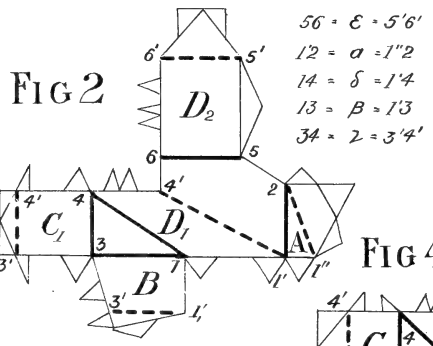
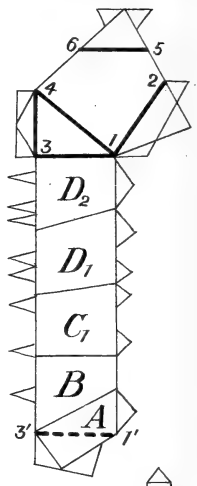
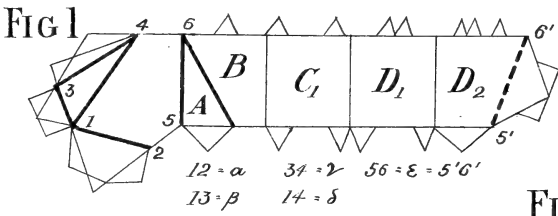
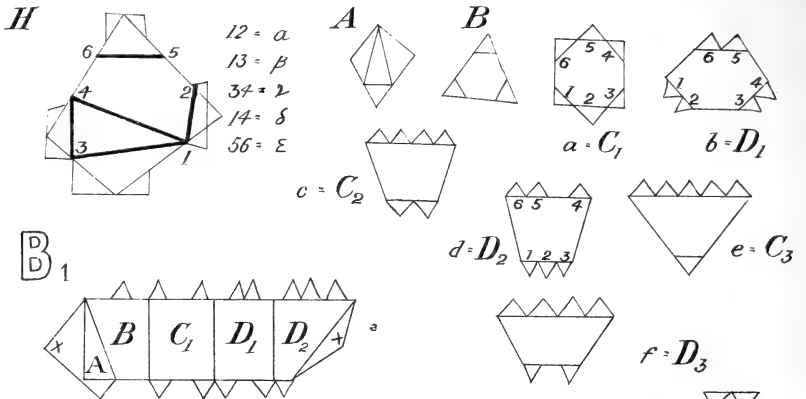

W.B.F.

On the  $k$ -partitions of the  $R$ -gon. By the Rev. Thos.  
P. Kirkman, M.A., F.R.S.

(Received, October 17th, 1893.)

A tape-face in a partitioned  $R$ -gon is either a triangle having only one edge, or a quadrilateral having two opposite edges, in the contour of the  $R$ -gon. No tape-face carries a marginal triangle.

The first step in the reduction of the general  $k$ -partitioned  $R$ -gon is to drop out all its tape-faces.

The 14-gon, Fig. 9, has four tape-faces. By dropping them out, we make it the 10-gon, Fig. 10, which has no tape-face.

Fig. 9 has thus lost 4 contour edges, and 3 diagonals, and therefore three faces.

The last operation in the construction of a definite partitioned  $R$ -gon, is the insertion of the tape-faces that it is intended to contain.

Our definitions and reasonings, until we come to handle the tape, Fig. 8, apply to partitions in which there is no tape-face.

*Definitions:* The bases of all marginal triangles of a partition are marginal diagonals.

All other diagonals are non-marginal.

A prime partition is one whose diagonals are all marginal. Figs.  $t, s, a, b, c, d, e, f, 6, 7$ , are primes.

A sub-marginal face has for an edge one, and only one, non-marginal diagonal, and carries  $i \geq 1$  marginal triangles.

A belt is a row of primes only, which have each more than two marginal triangles, and cohere each with the next by the united bases of two marginal triangles, that are

hidden, being both creased under.  $\mathfrak{B}_1$  is a belt of 5, Fig. 10 is a belt of 2, primes.

We are to conceive two marginal triangles creased under every non-marginal diagonal, in every partition.

When a belt falls asunder into its component primes, the undercreased marginal triangles are seen in their right position. Compare  $ABC_1D_1D_2$  in  $\mathfrak{B}_1$ , with  $ABabd$  out of  $\mathfrak{B}_1$ , in the figures.

In  $\mathfrak{B}_1$ , A and  $D_2$  are submarginal, but not in Figs. 1, 2, 3, 4, 5.

The belt  $\mathfrak{B}_1$  has 41 summits, besides the two terminals crossed, and has 19 faces.

2. Every face of a partitioned R-gon, which has two and only two non-marginal diagonals  $d d'$  for edges, may be and will be here considered, as a loose pane, and may fall out with its complete contour and fringe of marginal triangles, after which the two  $d d'$ , whether they have or not a common point, can become one; so that the number of non-marginal diagonals in the R-gon is diminished by one.

When a face has for edges  $3+i$  non-marginal diagonals it cannot fall out, so that the  $3+i$  non-marginal diagonals can become one, diminishing thus by one the number of non-marginal diagonals in R. In Fig. H is no face that can drop out. In  $\mathfrak{B}$  any one of  $A B C_1 D_1 D_2$  may so fall out; and any two, or all the five, can disappear with their marginal triangles. If all the primes that have for edges only two non-marginal diagonals were so to fall out of Figs. (1, 2, 3, 4, 5), nothing would be left of all the five but exactly our first figure H.

3. This H is *irreducible*, because it has no face, having two, and only two, non-marginal diagonals for edges.

*Definition*: A k-partitioned R-gon in which is a face that has for edges  $3+i$  non-marginal diagonals, but no



face having two, and only two, non-marginal diagonals, is an irreducible partition.

H has 23 summits and 14 diagonals. Its 15 faces are 9 marginal triangles, 4 sub-marginal faces, and 2 faces, a triangle and a pentagon, each of which has for edges 3 non-marginal diagonals that are the 5 dark edges of the figure.

An irreducible H may have any number of faces that have each for edges  $3+i$  non-marginal diagonals,  $i$  being different or not in any two such faces; and such edges will be called dark edges in H.

It is equally true that triangles and squares having two, and two only, non-marginal diagonals for edges, and carrying no marginal triangle, may fall out and leave only an irreducible H. Thus, if in Fig. H the dark line 65 be completed into either the triangle 655' or the 4-gon 6'655'. carrying no marginal triangle, either 655' or '6655' would have for edges two non-marginal diagonals  $d d'$ , and both could fall out, leaving, after union of each  $d$  and  $d'$ , exactly the irreducible H. We shall have to consider both the insertion and the dropping out of such simple faces. They form, when out of the *R*-gon, not a belt, but a tape, like Fig. 8.

The dark and dotted lines in Figs. (1, 2, 3, 4, 5), viz., the pairs 65, 6'5', 31, 3'1', &c., are the diagonals  $d d'$  that could unite if the primes between them were to fall out. The dark line on the right in A, Fig. 1 is an error—it should be not dark.

This brings out a novel and useful notion—that H can be completed into a *k*-partitioned *R*-gon by simply splitting its dark diagonals to receive one or more primes out of a given belt. And it is evident to the reader that there lies the secret of the construction upon H of Figs. (1, 2, 3, 4, 5).

4. If  $x$  be the number of the primes in the belt, and  $k$  the number of the dark diagonals of H, we have only to form all the *k*-partitions of  $x$ , as  $a_1, a_2, \dots a_k$ , whose sum of

$k$  parts is  $x$ , any number  $\overline{>0}$  of the parts beginning the partition being zero (as *e.g.*  $a_1 = a_2 = a_3 = 0$ , the rest being  $>0$ ); next, having named clearly our  $k$  dark diagonals as 1<sup>st</sup>, 2<sup>nd</sup>, 3<sup>rd</sup>, . . .  $k^{\text{th}}$ , we have to insert into the 1<sup>st</sup> split diagonal, the first  $a_1$  ( $\overline{>0}$ ) of the  $x$  primes in the belt; next to insert into the 2<sup>nd</sup> split diagonal the second number  $a_2$   $\overline{>0}$  of the remaining  $x - a_1$  primes in the belt, and so on, lifting and dropping the primes in their order till all the  $k$  dark diagonals have been, by the guidance of the same partition,  $a_1, a_2, \dots a_k$ , charged each with a given number  $a_i$   $\overline{>0}$ , of primes, leaving none in the belt.

We have to make the like use of the next  $k$ -partition of the number  $x$  to empty by its guidance the same full belt, by charges  $\overline{>0}$  placed in every split diagonal, till every  $k$ -partition has been so used to empty the same full belt.

If the number of the  $k$ -partitions of  $x$  so used is  $m$ , we shall have turned the same irreducible H into  $m$  different partitioned R-gons. We shall presently see what number  $m$  is, and be able to describe them. But our task is only begun by this handling of all the  $m$   $k$ -partitions of our number  $x$  of primes in our belt, each in dictionary order. We have to handle in the same way, for the charging of our  $k$  dark diagonals of H, every permutation of the parts of each of those  $m$   $k$ -partitions, emptying our full belt into the split diagonals  $M$  times; where  $M$  is the number of all the permutations of the  $k$ -partitions of  $x$ ; which  $M$  includes the number  $m$  of the  $k$ -partitions above handled unpermuted.

It is plain, that each of these  $M$  permutations bids us distribute in a different way our  $x$  primes into our  $k$ -split and unsplit dark diagonals, of which the  $i^{\text{th}}$  will be unsplit, when the  $i^{\text{th}}$  place of the guiding permutation is zero. But all this fuss of distribution is mere wind.  $M$  is all we really want, and that theorem  $\Omega$  gives at once.

5. It is then evident that the number of distributions of

the  $x=5$  primes of the belt  $\mathcal{B}_1$  into the  $k=5$  split and unsplit dark diagonals of  $H$ , is not less than  $M$ , that of all the permutations of the 5-partitions of the number 5, zeros and repetitions being allowed in the partitions.

By my theorem  $\Omega$  (*vide* the coming volume of Reprint of *Educational Times*), this number is the  $k^{\text{th}}$  co-efficient in  $(1+1)^{x+k-1}$ , *i.e.*, the 5<sup>th</sup> coefficient in  $(1+1)^{5+5-1}$ , which is  $9 \cdot 8 \cdot 7 \cdot 6 : 1 \cdot 2 \cdot 3 \cdot 4 = 126$ . This  $M=126$  is all the answer we can get if our  $x=5$  primes can be exhibited in no other belt besides one  $\mathcal{B}_1$ . This can be the case only when the primes are 5 squares in the belt, which out of it are 5 6-gons, that are capable of only one order and posture in a belt  $\mathcal{B}_1$ , having their marginal triangles all creased under and forming not a belt, but a tape, like figure 8. Such primes, having only two marginal triangles, are excluded by definition of a belt in Art. 1.

There are many belts. There is no second 6-gon  $A_2$ , nor second 9-gon  $B_2$ , having 3 marginal triangles; but there are three 14-gons ( $C$ ) and three 15-gons ( $D$ ) that all have 6 marginal triangles. These are the 2-zoned  $C_1$  and the monozones  $C_2$   $C_3$ , Figs. *a, c, e*; also the 3-zoned  $D_1$ , the asymmetric  $D_2$  and the monozone  $D_3$ , Fig. *b, d, f*.

To secure the construction of all our partitioned *R*-gons, these eight primes must all alike contribute to form a belt of five, the belts so formed being equivalents.

6. We have to use the 18 equivalent belts following :

$\mathcal{B}_1, ABC_1D_1D_2$ ;  $\mathcal{B}_4, ABC_1D_2D_3$ ;  $\mathcal{B}_7, ABC_1D_3D_1$ ;  
 $\mathcal{B}_2, ABC_2D_1D_2$ ;  $\mathcal{B}_5, ABC_2D_2D_3$ ;  $\mathcal{B}_8, ABC_2D_3D_1$ ;  
 $\mathcal{B}_3, ABC_3D_1D_2$ ;  $\mathcal{B}_6, ABC_3D_2D_3$ ;  $\mathcal{B}_9, ABC_3D_3D_1$ ;

nine belts in which is no repeated prime; and

$\mathcal{B}_{10}, ABC_1D_1D_1$ ;  $\mathcal{B}_{13}, ABC_1D_2D_2$ ;  $\mathcal{B}_{16}, ABC_1D_3D_3$ ;  
 $\mathcal{B}_{11}, ABC_2D_1D_1$ ;  $\mathcal{B}_{14}, ABC_2D_2D_2$ ;  $\mathcal{B}_{17}, ABC_2D_3D_3$ ;  
 $\mathcal{B}_{12}, ABC_3D_1D_1$ ;  $\mathcal{B}_{15}, ABC_3D_2D_2$ ;  $\mathcal{B}_{18}, ABC_3D_3D_3$ ;

nine in each of which is a repeated prime.

We have no  $i$ -ple prime in our belt. The least 2-ple is Fig 6; the least 3-ple is Fig 7. Observe that by  $i$ -ple we mean always zoneless  $i$ -ple

If we had used a prime having 12 marginal triangles, our belts, of  $x=$  five primes each, would be numbered not by half dozens, but probably by hundreds, all as much alike in features as are the above 18 equivalents of one selected belt.

We shall speak in Art. 8 of the  $\mu$  permutations of their order in the belt of the  $x=5$  primes, which are quite different from the above M permutations of the parts of all the  $m$  integral  $k$ -partitions of the mere number  $x$ . The numbers  $k$  and  $x$  may differ in any way or degree. Here  $x=k=5$  is convenient.

Each of the 18 belts will add 39 of its 41 not crossed (Art. 1) summits to the 23 of H (Art. 3), and 19 faces, of which 14 are marginal triangles, to the 15 faces of H.

At this point it is requisite that we clearly state the complete problem that we intend to solve. It is this—to enumerate the number of partitioned R-gons, that all alike fulfil the conditions following:—

1st. That they be all reducible to the same irreducible H, or to an irreducible identical with H, in the names of the polygons that compose H, two of which shall be exactly the 3-gon and the 5-gon that have for edges the dark diagonals in H.

2nd. That they each contain one of the 18 equivalent belts above described.

3rd. That they all contain the same tape, Fig. 8.

Observe, that no partitioned R-gon can contain more than one selected belt or tape, still less two irreducibles H.

Our problem resembles a famous old one: In how many ways can you put all of  $p$  things into  $n$  fixed places, leaving any  $i \geq 0$  of the  $n$  places vacant? In that, when  $e$  things are wanted to put in places chosen, any  $e$  of the  $p$  things, if they are all units, will serve as well as any other  $e$  of

the unplaced. But it is otherwise with our belt units. I call them units because each has to contribute a unit to the occupation of a place. To prevent confusion in our final account, it is necessary, and fortunately it is sufficient, to insist that if, directed by the first term of your guiding permutation (any one of the above  $M$ ), you begin by putting ( $c$ ) of my units in the place (the split diagonal) that you have first chosen, you shall take the first  $c$  in the belt before you; and that if you take  $d$  more to put into your second place, you shall take the next  $d$  in the belt; and, moreover, that my units in their new place shall sit in order, and wear their marginal triangles, exactly as they did in the belt.

The diagonal split has a name,  $12$ ,  $13$ , or  $ac$ ; where  $a < c$ . This  $a$  is in the lowest contour of the split; which must match the lower contour of the belt used.

7. It is here also important that we fix and name exactly our five places.

Call them Fig. H,  $a\beta\gamma\delta\epsilon$ ;  $12=a$ ,  $13=\beta$ ,  $34=\gamma$ ,  $14=\delta$ ,  $56=\epsilon$ ; and let the lowest point of each, standing vertical before you, be the above 5 first figures, 1, 1, 3, 1, 5.

We are to split  $12=a$  from 1 up to 2, and to separate the halves enough to admit between the parallels  $12$  and  $1'2'$  the portion of  $\mathfrak{B}_1$  that we are inserting, which inserted shall read from left to right, as it reads in the belt  $\mathfrak{B}_1$ .

And so exactly for  $13=\beta$ , &c.

This splitting and distributing is all imaginary work; whatever be  $k$  and  $x$ , the sum  $M$ , which is all we really want, of the  $k$ -partitions of  $x$  and their permutations, is given by my theorem  $\Omega$ . *Vide* page 211 of the *Proceedings* of this Society, 1892-3, where in line 9, *ab infra*,  ${}_k Q_x$  is to be read for  ${}_k Q$ .

The  $k$ -partitions of the number  $x$  here meant are those in which both zero parts and repeated parts are permitted, but not negative parts.

Two of the integral 5-partitions of 5 are 00005 and 11111, in dictionary order. We write them for our use thus :

$$\begin{array}{cc} \alpha\beta\gamma\delta\epsilon & \alpha\beta\gamma\delta\epsilon \\ 00005 & 11111 \end{array}$$

In Fig. 1,  $\alpha\beta\gamma\delta$  are vacant, and  $56 = \epsilon$  is split to receive the whole belt  $\mathfrak{B}_1$ .

In the Plate, Fig. 1 shows two dark lines in A, by mistake, instead of the single one 56.

In Fig. 2, the first place  $\alpha$  is split to receive the first unit A of  $\mathfrak{B}_1$ ; the second,  $\beta$ , to receive B; the third,  $\gamma$ , to receive  $C_1$ ; the places  $\delta\epsilon$  to receive  $D_1$  and  $D_2$ , all of  $\mathfrak{B}_1$ .

In both figures, the primes stand in their order and in their postures, under their marginal triangles, as they stood in the belt  $\mathfrak{B}_1$ .

The dotted edges are the shifted halves of the dark diagonals. These two partitions have guided us to two distributions of  $\mathfrak{B}_1$ .

Two of the M permutations of the 5-partitions of 5 are 05000 and 20111, not in dictionary order. We write them for use thus

$$\begin{array}{cc} \alpha\beta\gamma\delta\epsilon & \alpha\beta\gamma\delta\epsilon \\ 05000 & 20111 \end{array}$$

In Fig. 3,  $\beta = 13$  is split to receive the whole belt  $\mathfrak{B}_1$ .

In Fig. 4 the first place is filled with AB; the second,  $\beta = 13$  is vacant; the three last places in order are split to receive  $C_1D_1D_2$ . Thus these two permutations have guided us to two correct distributions of  $\mathfrak{B}_1$ . All the primes in both, read in the order of the places  $\alpha\beta\gamma\delta\epsilon$ , stand as they stood in the belt. Of Fig. 5 we shall speak later.

The figures 1, 2, 3, 4 are not very like partitioned R-gons; but if the numbered summits (Art. 6) be 62 successive points on a circle, the diagonals be drawn, and the marginal triangles be completed, there will be seen an inscribed partitioned polygon of 62 summits.

8. The number of belts that we have handled is 18. We have virtually multiplied every one of these by its partition-factor, which is 126, the number  $M$  of the permutations of the  $(k=)5$ -partitions, of  $(x=)5$ . That is, we have constructed

$$18 \cdot 126 = 2268$$

34-partitions of a 62-gon by the distribution upon the irreducible  $H$  of our 18 unpermuted belts.

In 9 of these belts which have 5 different units (Art. 5) there can be made  $\mu = 120$  permutations of the 5 primes without altering the posture of any one under its marginal triangles.

In the other 9, in which two of the 5 units are identical, these two can be made or supposed to wear their marginal triangles alike, after which the 5 primes can undergo  $\mu = 60$  permutations with postures unchanged under marginal triangles. In either nine every permutation of its primes makes it a belt unused before; so that the actual number of belts is  $9 \cdot 120 + 9 \cdot 60 = 1620$ . Here  $\mu = 120$  is the permutation-factor of each of the first nine, and  $\mu = 60$  is the permutation-factor of each of the second nine. The partition-factor is the same  $M = 126$  for each of the eighteen belts. Hence

$$126(9 \cdot 120 + 9 \cdot 60) = 204120$$

is the number of 34-partitioned 62-gons obtained by distribution upon  $H$  of all the 18 permuted belts unaltered in posture of their primes.

9. We have next to consider the changes possible in our belt  $\mathfrak{B}_1$  (call it  $\mathfrak{B}_{1,1}$ ), by an alteration not in the position as to order of a prime in it, but in the way in which the primes wear their marginal triangles. Thus  $A$  in  $\mathfrak{B}_1$  can wear, as  $B$  wears, its triangle above, giving to  $\mathfrak{B}_{1,1}$

a summit more above and one fewer below. Make that change, and call the new figure  $\mathfrak{B}_{1,2}$ . This  $\mathfrak{B}_{1,2}$  is a 19<sup>th</sup> equivalent belt, which we have to distribute, like  $\mathfrak{B}_{1,1}$ , 126·120 times.

If we now make any other such a change of posture in any one, any two together, or in every prime at once in  $\mathfrak{B}_{1,1}$ , the new figure will be  $\mathfrak{B}_{1,3}$ , which we have to distribute 126·120 times.

The same is true if the belt in which we change one or more postures of its primes, but not their order, be *any* one  $\mathfrak{B}_c$  of the first nine belts that are capable of 120 permutations of their primes. We distribute  $\mathfrak{B}_{c,1}$ ,  $\mathfrak{B}_{c,2}$ , &c.

If the belt handled be  $\mathfrak{B}_k$ , say  $\mathfrak{B}_{k,2}$ , one of the nine that can have only 60 such permutations, the new belts  $\mathfrak{B}_{k,2}$ ,  $\mathfrak{B}_{k,3}$ , &c., can each be distributed, like  $\mathfrak{B}_{k,1}$ , only 126·60 times.

A prime in a belt can change its posture under its marginal triangles by using a different *base-tie*.

*Definition:* A base-tie of a prime is a line not drawn but conceived as drawn, bisecting two bases of its marginal triangles that have or have not a common summit, the prime being complete, *i.e.*, not in a belt concealing creased triangles. In a belt the base-tie bisects two non-marginal diagonals.

The number of different ways in which a prime can wear in a belt its marginal triangles is the *posture-number* of the prime.

The product of all the posture numbers of its primes is the *posture-factor*  $\Pi_c$  of a belt  $\mathfrak{B}_c$ .

10. The changes of posture of its primes may be considered to take place either before their distribution or after, as follows:—

Consider our first belt  $\mathfrak{B}_1$  distributed in Fig. 2 by Art. 6. Let now all the primes so distributed but two, whose



posture numbers are  $f$  and  $g$ , keep their postures which we see in Fig. 2 and in  $\mathfrak{B}_1$ , while the other two exhaust all their possible combined changes of posture, which are  $fg$  changes, each once counted. It is clear that Fig. 2 will assume  $fg$  different forms, by variations of posture in only two of the distributed primes. Next let only two primes keep their postures, while the three, whose posture-numbers are  $fg$  and  $h$ , assume all their possible  $fgh$  combined postures, each of the  $fgh$  once. We looking on shall have seen in Fig. 2  $fgh$  different configurations made by 3 primes, combined with the unchanged attitude of the two others. If  $i$  and  $j$  be the posture-numbers of these two, they could assume each of their  $ij$  combined postures in succession, and in company with every single one of the three  $fgh$ . That is, Fig. 2, without change in the distribution or order of its five primes, can take  $fghij = \Pi_2$  different configurations, all different partitions of the  $R$ -gon so far constructed.

But Fig. 2 is only one of  $126 \cdot 120$  distributions upon  $H$  of  $\mathfrak{B}_1$  and its  $120$  permutations, in which all the primes all through use the same base ties. Wherefore, after insertion of  $\mathfrak{B}_1$  into  $H$ , we can obtain in all, by changes of order and posture of its so distributed primes,  $126 \cdot 120 \Pi_1$ , and no more, differently partitioned  $R$ -gons, where  $126$  is the partition factor of  $\mathfrak{B}_1$ ,  $120$  its permutation factor, and  $\Pi_1$  its posture factor.

The first factor is always given by theorem  $\Omega$ , the second by first lessons in Algebra, and the third is elementary in the theory of the Polyedra. We are about to see that  $126 \cdot 120 \Pi_1 = 544,320,000$ .

II. The next thing requisite, and enough for our purpose here, is a rule for the posture-number of a prime reticulation.

A  $2i$ -zoned prime can take only one posture when using a zoned polar base-tie; upon a zonal or epizonal base-tie it can take two postures.

Every prime can, face-up and face-down, take two postures upon a zoneless polar base-tie, and four postures upon an asymmetric base-tie.

In order to use correctly the following rules for the posture-number of any prime, it is only necessary to know whether the prime be  $i$ -zoned,  $i$ -ple, or asymmetrical.

1. An  $i$ -zoned prime,  $\overline{i} > 1$ , having, out of a belt,  $m$  marginal triangles, can take in a belt, by using all its base-ties,  $m(m-1)i^{-1}$  postures, and no more.

2. An  $i$ -ple prime,  $\overline{i} > 2$ , having, out of a belt,  $m$  marginal triangles, can take in a belt, by using all its base-ties,  $2m(m-1)i^{-1}$  postures, and no more.

3. An asymmetric prime that has, out of a belt,  $m$  marginal triangles, can take in a belt, face-up and face-down,  $2m(m-1)$  postures, and no more.

This gives us, if  $\pi$  be the posture-number of a prime, and  $m$  the number of its marginal triangles,

|         |                             |          |             |
|---------|-----------------------------|----------|-------------|
| For the | 3-zoned A,                  | $m = 3,$ | $\pi = 2;$  |
| „       | 3-zoned B,                  | $m = 3,$ | $\pi = 2;$  |
| „       | 2-zoned C <sub>1</sub> ,    | $m = 6,$ | $\pi = 15;$ |
| „       | 3-zoned D <sub>1</sub> ,    | $m = 6,$ | $\pi = 10;$ |
| „       | 1-zoned C <sub>2</sub> ,    | $m = 6,$ | $\pi = 30;$ |
| „       | 1-zoned C <sub>3</sub> ,    | $m = 6,$ | $\pi = 30;$ |
| „       | 1-zoned D <sub>3</sub> ,    | $m = 6,$ | $\pi = 30;$ |
| „       | asymmetric D <sub>2</sub> , | $m = 6,$ | $\pi = 60.$ |

The table following gives the posture-factor of every belt, as the product of five posture-numbers:—

|                                                                                                      |                                                                                                             |
|------------------------------------------------------------------------------------------------------|-------------------------------------------------------------------------------------------------------------|
| $\mathfrak{B}_1$ , AB C <sub>1</sub> D <sub>1</sub> D <sub>2</sub><br>2'2'15'10'60; $\Pi_1 = 36000$  | $\mathfrak{B}_{10}$ , AB C <sub>1</sub> D <sub>1</sub> D <sub>1</sub><br>2'2'15'10'10; $\Pi_{10} = 6,000$   |
| $\mathfrak{B}_2$ , AB C <sub>2</sub> D <sub>1</sub> D <sub>2</sub><br>2'2'30'10'60; $\Pi_2 = 72000$  | $\mathfrak{B}_{11}$ , AB C <sub>2</sub> D <sub>1</sub> D <sub>1</sub><br>2'2'30'10'10; $\Pi_{11} = 12,000$  |
| $\mathfrak{B}_3$ , AB C <sub>3</sub> D <sub>1</sub> D <sub>2</sub><br>2'2'30'10'60; $\Pi_3 = 72000$  | $\mathfrak{B}_{12}$ , AB C <sub>3</sub> D <sub>1</sub> D <sub>1</sub><br>2'2'30'10'10; $\Pi_{12} = 12,000$  |
| $\mathfrak{B}_4$ , AB C <sub>1</sub> D <sub>2</sub> D <sub>3</sub><br>2'2'15'60'30; $\Pi_4 = 108000$ | $\mathfrak{B}_{13}$ , AB C <sub>1</sub> D <sub>2</sub> D <sub>2</sub><br>2'2'15'60'60; $\Pi_{13} = 216,000$ |
| $\mathfrak{B}_5$ , AB C <sub>2</sub> D <sub>2</sub> D <sub>3</sub><br>2'2'30'60'30; $\Pi_5 = 216000$ | $\mathfrak{B}_{14}$ , AB C <sub>2</sub> D <sub>2</sub> D <sub>2</sub><br>2'2'30'60'60; $\Pi_{14} = 432,000$ |
| $\mathfrak{B}_6$ , AB C <sub>3</sub> D <sub>2</sub> D <sub>3</sub><br>2'2'30'60'30; $\Pi_6 = 216000$ | $\mathfrak{B}_{15}$ , AB C <sub>3</sub> D <sub>2</sub> D <sub>2</sub><br>2'2'30'60'60; $\Pi_{15} = 432,000$ |
| $\mathfrak{B}_7$ , AB C <sub>1</sub> D <sub>3</sub> D <sub>1</sub><br>2'2'15'30'10; $\Pi_7 = 18000$  | $\mathfrak{B}_{16}$ , AB C <sub>1</sub> D <sub>3</sub> D <sub>3</sub><br>2'2'15'30'30; $\Pi_{16} = 54,000$  |
| $\mathfrak{B}_8$ , AB C <sub>2</sub> D <sub>3</sub> D <sub>1</sub><br>2'2'30'30'10; $\Pi_8 = 36000$  | $\mathfrak{B}_{17}$ , AB C <sub>2</sub> D <sub>3</sub> D <sub>3</sub><br>2'2'30'30'30; $\Pi_{17} = 8,000$   |
| $\mathfrak{B}_9$ , AB C <sub>3</sub> D <sub>3</sub> D <sub>1</sub><br>2'2'30'30'10; $\Pi_9 = 36000$  | $\mathfrak{B}_{18}$ , AB C <sub>3</sub> D <sub>3</sub> D <sub>3</sub><br>2'2'30'30'30; $\Pi_{18} = 108,000$ |
| 810,000                                                                                              | 1,380,000                                                                                                   |

By our subsequent changes of postures in 126 times distributed primes in the 120 times or 60 times permuted belts, we multiply every posture-factor in this table either by 126·120 or by 126·60.

It follows that the sum *S* of all the partitions of the *R*-gon thus far constructed is

$$126 \cdot 120 \cdot 810000 + 126 \cdot 60 \cdot 1380000 = S \text{ or } S = 22,680,000,000.$$

We need not distress ourselves about the underincreased triangles in this hurly-burly of changing base-ties. The pretty primes are nimble and well drilled. There is no fear of damage to their wings in these thousands of millions of evolutions.

12. In Fig. 4 and 5 are seen different postures of the five distributed primes of the unpermuted  $\mathfrak{B}_1$ .

In 4,  $D_2$  uses its base-tie 13 (Fig. *d'*); in 5 it uses 12 of (*d'*); the third triangle in (*d'*) being hid in 4 and seen in 5, while the second triangle in (*d'*) is seen in 4, but hid in 5.

In 4,  $D_1$  uses its base-tie 14 of (*b*); in 5,  $D_1$  uses 12 of (*b*). In 4,  $C_1$  uses 52 of (*a*); in 5,  $C_1$  uses 54 of (*a*). In 5 A and B have each made a revolution about its base-tie, used in 4. B, in 5, should have a small marginal triangle on the left at the fracture between 1 and 1'.

The above S results would be nearly all that is required, had we not to give an account of a third datum (Art. 6) which is the tape, Fig. 8, of three triangles and three rect angles that carry no marginal triangle.

All the S partitions above made have each (Art. 3) 33 diagonals, *i.e.*, places to receive, after splitting the proper diagonals, the 6 units of the tape, which, after each distribution of them, will have added six faces to the 34 in each of the S partitions.

Instead of 5,  $\alpha\beta\gamma\delta\epsilon$ , we have now 33 places to name, to fix, and to split; in these we include the bases of the 23 marginal triangles in H, and in each of the 18 distributed belts; for by splitting such bases we cannot introduce a new submarginal, as the tape carries no marginal triangle.

13. Our distribution of the tape can be exactly effected in  ${}_{33}\mathbb{R}_6$  different ways, which is the number of permutations of the 33-partitions of 6, without altering the order or the posture of any prime in the tape. Such prime, out of the tape, has two marginal triangles that in the tape are hid.

This  ${}_{33}\mathbb{R}_6$  is by theorem  $\Omega$ , Art. 5, the  $33^{\text{rd}}$ , which is also the 7<sup>th</sup>, coefficient of  $(1+1)^{6+33-1}$ , or

$$\frac{38 \cdot 37 \cdot 36 \cdot 35 \cdot 34 \cdot 33}{1 \cdot 2 \cdot 3 \cdot 4 \cdot 5 \cdot 6} = 2760681.$$

This is the partition-factor of the tape. Its permutation and posture-factors are 20 and 8, so that we have 160 tapes to distribute, which are all one (Art. 6).

The product of the three factors is

$$20 \cdot 8 \cdot 2760681 = 441708960 = T.$$

Since each of these T variations of our distributed tape will be combined with all the preceding S configurations, without changing anything in the latter, we shall obtain

$$\begin{aligned} \text{TS} &= 441708960 \times 22680000000, \\ &= 10017959212800000000 \end{aligned}$$

different partitions of our R-gon. The (19+15)-partitioned (39+23)-gon (Art. 3) has become by addition of the 6 faces and 9 summits of the tape, a 40-partitioned 71-gon, and we have formed T.S of these asymmetrical propyramidal 71-gons, no one of which is either the repetition or the reflected image of another. That is, if M be a million, we have formed of them

$$10M^3 + 17959M^2 + 212800M.$$

If the submarginals in H, standing on the dark edges 43 and 21, be detached, the first is seen to be the prime A, and the second is a square under four marginal triangles; and evidently neither of these could change the figure H by undercreasing another triangle. The marginal diagonal of that A should begin at 4.

The submarginals on the dark edges 65 and 31 are monozones, each of which can, by undercreasing its other two triangles, place its zonal trace in three positions, and thus the two together can, still occupying 65 and 31, give to H 3·3=9 configurations.

Further, these four submarginals can occupy the edges 43, 21, 65, and 31 in 24 different ways, and by the same changes of two concealed marginal triangles turn H into 24·9=216 equivalent H's, all of which have been virtually handled by us, and have each given us the same number T.S of 40-partitioned 71-gons. Thus we have constructed more than 2,000 millions of billions of them, namely,

$$216.T.S = 2163M^3 + 879189M^2 + 964800M.$$

Each of them *could* be crowned upon its 23 marginal triangles by a different asymmetric propyramidal 23-ace, and the similar 216TS 23-aces *could* be by one entry registered as a small fraction of all the asymmetrical propyramidal 23-aces, built by other belts on other irreducibles, that are to be found among the asymmetric summits of the 72-acral 63-edra.

But since, in the solution of the problem of the Polyedra, no asymmetric summits are obtained by coronation, none of these 40-partitioned 71-gons are required in that solution.

All asymmetric summits, the *a*-aces, *b*-aces, &c., are given in that theory by their reciprocal *a*-gons, *b*-gons, &c., in the 63-acral 72-edra, which faces are obtained by their edges, constructed in vast numbers by crowning (or imagining so crowned) penesolids with those edges. The only asymmetric reticulations of use in the study of Polyedra are quite elementary ones, by the zoned and zoneless repetition of which round a circle are formed the symmetricals that alone are crowned, and give the *i*-zoned and *i*-ple summits. Those small ones are readily obtained by inspection of previous tables, in which they have been again and again used.

This general problem of the *k*-partitions of the *R*-gon is outside the theory of Polyedra. It may yet find its use in analysis.

15. We have not above solved this general problem in terms of *k* and *R*; that, I fear, is impossible. But it will be seen that when with *k* and *R* are given the list of faces in the irreducible *H*, with the number of its non-marginal diagonals of which each is in a face that has more than one other non-marginal diagonal among its edges, and when the faces in *R* that have each two, and only two, non-marginal diagonals for edges are exactly given, whether they carry or do not carry one or more marginal triangles, that

the problem is completely solved. And it is evident that whatever be our data, as irreducible, as belt, and as tape, it is impossible that 2 of our constructions can be alike, unless the primes are twice distributed in the same way, by the guidance of the same permutation of the diagonals that may be split to receive the primes. And this, *twice*, is clearly impossible, because the number *M* of those permutations is exactly given by theorem  $\Omega$ , and none of them is twice used; *vide* Art. 7.

It is impossible, also, that any one of our constructions should be the reflected image in any position of another; because the reflected image of *H* has never been used.

If in a partitioned *R*-gon there is no irreducible *H*, the *R*-gon is either a belt in which a tape is or is not distributed, or it is a pair of collateral submarginals in which a tape is or is not distributed, or it is a tape.

The tape in every case can be dropped out, and the belt that remains can have all its possible configurations enumerated by the above method, after which the tape can be inserted again in every way possible.

Thus all the possible different *k*-partitions can be determined, both symmetric and asymmetric. But all the faces must be exactly given in the sense in which the faces of our 18 belts were given in any single belt of them.

Hence it is quite correct (Art. 6) to say that no *k*-partitioned *R*-gon can have more than one irreducible *H*, one belt, or one tape, although each of the three may have many *equivalents*, due to permutation and altered posture of the primes, and to the equal right, which like primes,  $C_1C_2C_3 \dots D_1D_2D_3 \dots$  (Art. 5) have to every possible admission into the equivalent belts.

The number of distinct equivalent belts that we have used in the pages preceding (Art. 11) is  $9 \cdot 120 \times (\Pi_1 + \Pi_2 + \dots + \Pi_9) + 9 \cdot 60 \times (\Pi_{10} + \Pi_{11} + \dots + \Pi_{18})$ ; and these are all given with any one of them that may be first handled

and called  $\mathfrak{B}_1$ . The number of equivalent tapes used is  $1 \cdot 20 \cdot 8 = 160$ .

16. There are yet questions about primes, belts, and irreducibles that might be easily raised and disposed of in reasonable limits; but they are forbidden ground. They are too closely connected with the elementary theory of the polyedra, upon the teaching and learning of which, over 30 years ago, was imposed, by the highest scientific tribunal, a solemn and dire taboo. This is on record in p. 165, Vol. CLII., 1862, of the *Philosophical Transactions*, in the very last printed sentence of my complete Theory of the Polyedra, thus: "Thus we have demonstrated, in this second section, that the data of article xxxvi. are sufficient for the entire completion of the tables A, B, C, D (xxxv. . . . xxxvi.) for faces and for summits. All that remains for the complete solution of our problem, of classification and enumeration of the P-edra Q-acra and of the P-acra Q-edra, is that we show how these data can be obtained and registered, without ambiguity or repetition. We shall consider first the reciprocals of the faces ( $d$ ) ( $f$ ) xxxvi., and the edges ( $g$ ) xxxvi."

The taboo is the sudden, loud, and long silence of that close.

My first two sections are very summary statements of things to be distinguished and well-arranged in large groups before handling in detail, and not quite easy to a reader of less than a De Morgan's power. De Morgan read them easily, and very early, without a complaint of my obscurity, and, simply and only from the little just printed, so far shaped to himself what was coming, that he could write the letter now before me, dated "Adelaide Road, N.W., April 18, 1862," expressing his satisfaction with it, with acute and kind remarks on the success which he foresaw. But then, I am here bound by candour to own that Professor De Morgan,



whom I never saw three times, was not of the Council, nor even a Fellow, of the Royal Society.

That letter is the only evidence, direct or indirect, that has yet reached me, that any competent judge, dead or alive, ever tried to read six pages of mine on this subject, printed or in my MS.

Of my definite teaching *ab initio*, to which a student at the beginning would gladly turn, the first lessons are all in my third section, which is evident in the above quotation. Not a line of the third section was permitted to see the light in 1862. And I have been informed by the Secretary of the Royal Society that they have no intention to print more of my *Memoir*.

I have to confess that, a few years ago, I was tempted to a violation—a very little violation—of this dread taboo. Of that impiety I hope to die sufficiently penitent; and I am confident that I am much too virtuous to repeat the sin. It is this—in Vol. XLIII., 1888-9, of the *Proceedings* of the Literary and Philosophical Society of Liverpool, there is, plentifully illustrated by plates containing 70 figures, an analysis and synthesis of four autopolar solids, three that have each six, and one that has nine, different edges.

Of this taboo, for my very brief time, I make no complaint. My two first sections printed contain, not a production—our planet is yet but young—but a sufficient protection, of my theorems. And I am very far from denying that what was done with them was perfectly regular and in order, and simply what, when a like somewhat rare case recurs, will with equal propriety be done again.

Wherefore I sing lustily, and shall sing to the end, the song they have taught me—*Procul este, profani! Floreat Taboo!*

It is a genuine and an effectual taboo. For it has a droll side, which I leave to the reader who knows a little about the Grand Prize Question that, early in 1858, was

published by the French Academy for their world competition in 1861, was in 1862 kept open for another year, and was apparently closed without result in 1864: *vide Comptes Rendus*, 1858, Vol. XLVI., p. 301; and 1862, Vol. LV., p. 989.

There is often amusement in a contrast, and sometimes in agreement. At the moment when the Academy were recording, in that page (989), their decision to repeat, for a fourth successive year, their offer to the circles of latitude of their gold and honour for one who should work out ‘en quelque point important la théorie géométrique des polyèdres,’ that and every other important point of the completed theory (completed before 1858) had, months ago, been presented in London, and had there been flung aside as a troublesome cumbrance, to be mentioned never more for that generation. That was perfectly in order, and has been as such accepted by all, for 33 years.

The reader will none the less enjoy what he finds of droll in this taboo, if he has detected in that grave page (989) a half-hidden twinkle or two of harmless fun.

It has also a serious side, that alone concerns me, in the duty which my reverence for the Royal Society lays on me, of shunning in future all breach of their taboo.

The bold student, who in another lifetime or two may have the valour to smash it, will see that my good fortune in these k-partitions of the R-gon is due, first, to my theorem  $\Omega$ , and next, to an old and very successful device. In the Polyedra the diagonals under my propyramidal edges and symmetrical summits were split for the insertion of tapes of pyramidal bases, with vertices downwards, which were all, by an easy routine of inspection of completed tables, afterwards registered as higher and still higher metapyramidals, in groups ever larger and larger, each with its symmetry and deletes to be read in one entry, soon enormous, without ambiguity in class or number.

Of anything like a reason for the taboo I know nothing that is not to be read in lines 4, 5 . . . of page 72 (the last but three of the paper) of the Liverpool volume above named.

Of my paper in that volume I can give a copy to the mathematician who thinks it worth while to inform me of his wish and intention to read it.

---

**On the Osmotic Pressure of Solutions of finite Concentration. By Thomas Ewan, B.Sc., Ph.D., 1851 Exhibition Scholar in the Owens College.**

*(Received December 12th, 1893.)*

In 1885, van't Hoff\* showed that the equation  $PV = RT$ , which expresses the connection between the pressure, temperature, and volume of a perfect gas, is also true for the osmotic pressure of a solution. The behaviour of most solutions is not in strict accord with this equation, and my object in this note is to take into account certain factors which are omitted in the simple equation  $PV = RT$ , and so obtain an expression which shall approximate more nearly to the truth.

The most important of these factors is the heat of dilution, as van't Hoff pointed out. He says, after showing that the equation  $PV = RT$  applies both to gases and solutions :

“Seulement la même réserve nécessaire dans l'application en cas des corps gazeux convient encore ici, et l'analogie qu'offrent ces deux états de la matière est telle que l'origine de la restriction est absolument la même dans les deux cas. Aussitôt que la concentration, soit dans les gaz soit dans les corps dissous, est telle que l'action mutuelle des particules n'est plus négligeable on sait que dans le premier cas les déviations se font sentir et de même le raisonnement sur lequel se basent, pour la solution les lois déduites ne peut plus être accepté dans ces circonstances. Ajoutons que pour les solutions, un phénomène facile à produire trahit l'existence de l'action mutuelle des particules dissoutes ; ces actions donnent lieu à la production de travaux intérieurs dans l'acte de dilution, qui se manifestent dans leur équivalent

---

\* *K. Svenska Vet. Ak. Handlingar* 21. No. 17. 1885.

“thermique ; par conséquent les lois exposées s’appliquent à des solutions tellement diluées que la chaleur de dilution devient “négligeable.”

I have obtained the equations connecting osmotic pressure, temperature, volume, and heat of dilution of a solution, and on giving the value zero to the heat of dilution the equations become identical with van’t Hoff’s.

*Connection between Osmotic Pressure and Temperature.*

The osmotic pressure of a solution cannot be directly measured with any great accuracy, but it can be calculated from the vapour pressure of the solution or from its freezing point.

The relation between the osmotic pressure and the vapour pressure of a solution was first given by van’t Hoff (*loc. cit.*) and afterwards reproduced by other authors, first by Gouy and Chaperon.\* The form given by the latter is :—

$$PK \cdot \frac{M_o}{\Delta_o} = RT \log \frac{p_o}{p}$$

where P = the osmotic pressure at T.

K is a coefficient which depends on the contraction which takes place when the solution is diluted.

$M_o$  is the molecular weight of the solvent (as gas).

$\Delta_o$  is the density of liquid solvent.

$p_o$  and  $p$  the vapour pressures of the solvent and solution respectively, and

R the gas constant for 1 gram molecule.

The coefficient K is defined by Gouy and Chaperon† by the following equation :—

$$K = \frac{\Delta_o}{\Delta} \left( 1 - \frac{d\Delta}{dw} \right)$$

$\Delta$  being the density of the solution and  $w$  the quantity of

\* *Ann. Chim. Phys.* (6), XIII., p. 120. 1888.

† *Ann. Chim. Phys.* (6) XII., p. 384. 1887.

solvent it contains to a given quantity of dissolved substance.

We may therefore consider  $K \frac{M_o}{\Delta_o}$  as the increase of volume which an infinitely large quantity of the solution would experience if  $M_o$  grams (= 1 gr. molecule) of the solvent were added to it. Call  $K \frac{M_o}{\Delta_o} = v_o$  and write the equation :

$$Pv_o = RT \log \frac{p_o}{p} \quad . \quad . \quad . \quad . \quad . \quad (1)$$

This equation is true for solutions of any concentration, and is only subject to the restriction that the vapour of the solvent over the solution may be considered as a perfect gas.

The connection between the osmotic pressure and the freezing point of a solution may be obtained as follows. According to Kirchhoff's† well-known equation connecting the heat of dilution of a solution with its vapour pressure we have :

$$-\frac{dQ}{dw} = \frac{RT^2}{JM_o} \frac{d}{dT} \log \frac{p_o}{p}$$

where  $J$  is the mechanical equivalent of heat, and  $\frac{dQ}{dw}$ —the heat of dilution—is taken positive when heat is evolved on dilution.  $\frac{dQ}{dw}$  is very nearly independent of temperature. As a first approximation its variability may be neglected, and the equation integrated gives

$$\log \frac{p_o}{p} = k + \frac{JM_o}{RT} \frac{dQ}{dw} \quad . \quad . \quad . \quad . \quad . \quad (2)$$

The constant  $k$  is of considerable importance, it is independent of temperature, but varies with the concentration of the solution. Its value may be obtained as follows:—The heat required to melt 1 gr. molecule of the solid solvent at any temperature  $T$  (call it  $w_T$ ) is given by the expression

$$w_T = \frac{RT^2}{J} \frac{d}{dT} \log \frac{p_1}{p_o}$$

† *Ann. Phys. Chem.* 103, p. 177. 1858.

where  $p_1$  is the vapour pressure of the solid at  $T$ , and the other letters have their former signification.

We also have

$$w_T = w_o - (c_o - c_1)(T_o - T),$$

where  $w_o$  = latent heat of fusion for 1 gr. mol. solvent at  $T_o$ .

$T_o$  = melting point of solvent.

$c_o$  and  $c_1$  = capacity for heat for 1 gr. mol. liquid and solid solvent respectively. Call  $(c_o - c_1) = c$  and we get

$$w_o - c(T_o - T) = \frac{RT^2}{J} \cdot \frac{d}{dT} \log \frac{p_1}{p_o}.$$

Integrating this equation between the limits  $T_o$  and  $T$ , and remembering that at  $T_o$

$$p_1 = p_o$$

we get

$$\log \frac{p_1}{p_o} = \frac{J}{R} \left[ w_o \frac{T - T_o}{T_o T} - c \left( \frac{T - T_o}{T} - \log \frac{T}{T_o} \right) \right]$$

after expanding  $\log \frac{T}{T_o}$  and neglecting terms after the second this becomes :

$$\log \frac{p_1}{p_o} = \frac{J}{R} \left[ w_o \frac{T - T_o}{T_o T} + \frac{c}{2} \left( \frac{T - T_o}{T} \right)^2 \right] \dots \dots (3)$$

Now at the freezing point of a solution its vapour pressure is the same as that of the solid solvent at the same temperature.

Call the freezing point of the solution  $F$ . At  $F$ , therefore,  $p = p_1$ , and therefore

$$-\log \frac{p_1}{p_o} \left( = \log \frac{p_o}{p_1} \right) = \log \frac{p_o}{p}.$$

At  $F$ , therefore, we have from equations (2) and (3), by putting  $T = F$  and writing the quantities on the right hand side of (2) equal to those on the right of (3) with negative sign, and after making all reductions,

$$k = \frac{J}{R} \left[ w_o \frac{T_o - F}{T_o F} - \frac{c}{2} \left( \frac{T_o - F}{F} \right)^2 - \frac{M_o}{F} \frac{dQ}{dw} \right] \dots \dots (4)$$

Substitute this value of  $k$  in equation 2, and it becomes

$$\log \frac{p_o}{p} = \frac{J}{R} \left[ w_o \frac{T_o - F}{T_o F} - \frac{c}{2} \left( \frac{T_o - F}{F} \right)^2 - \frac{M_o}{F} \frac{dQ}{dw} \frac{T - F}{T} \right] \quad (5)$$

and finally equation (1), gives

$$\log \frac{p_o}{p} = \frac{P v_o}{RT}$$

which value substituted in 5 gives

$$P v_o = J \left[ w_o T \frac{T_o - F}{T_o F} - \frac{cT}{2} \left( \frac{T_o - F}{F} \right)^2 - M_o \frac{dQ}{dw} \frac{T - F}{F} \right] \quad (6)$$

In the following table the vapour pressures of some copper chloride solutions calculated from their freezing points, by means of equation (5), are compared with those found. The determinations used were made by Mr. Ormandy and myself.\*

| Concentration<br>in grams. CuCl <sub>2</sub><br>to 1 gr. water. | T <sub>o</sub> - F | $\frac{dQ}{dw}$ (Thomsen) | p. cal. | p. found. | Diff. |
|-----------------------------------------------------------------|--------------------|---------------------------|---------|-----------|-------|
| ·05                                                             | 1'905              | ·22                       | 15'086  | 15'033    | ·053  |
| ·1                                                              | 4'12               | ·78                       | 14'788  | 14'706    | ·082  |
| ·2                                                              | 9'63               | 2.48                      | 14'104  | 14'035    | ·069  |

The differences are rather larger than the error in the measurements of the vapour pressures, but may be due to some extent to errors in the freezing points.

Equation (5) also shows that  $v$ . Babo's law, according to which  $\frac{p_o}{p}$  is independent of temperature is only true when  $\frac{dQ}{dw} = 0$ .  $Q \frac{p_o}{p}$  will evidently decrease with rising temperature when  $\frac{dQ}{dw}$  is positive, and *vice versa*. This conclusion has already been reached by Dieterici,† though in a different way.

\* *Chem. Soc. Journ.*, 1892, p. 769.

† *Wied. Ann.*, 45, p. 207, 1892.



A number of interesting conclusions may be obtained from equation 6.

(a) At the freezing point of a solution the external work done when solvent is added to it in a reversible way is independent of the nature of the dissolved substance, and it is the same for all solutions in the same solvent which have the same freezing point. The equation for the osmotic work becomes at F—

$$Pv_o = J \left[ w_o \frac{T_o - F}{T_o} - \frac{cF}{2} \left( \frac{T_o - F}{F} \right)^2 \right]$$

This equation was first obtained by Arrhenius,\* in 1892, in a slightly different form, and in a different way.

(b) Again dividing equation 6 by T and bringing all the terms which are independent of T together into one constant, we get

$$\frac{Pv_o}{T} = \text{const} + \frac{JM_o}{T} \frac{dQ}{dw}$$

It is easy to see from equations (1) and (2) that this may also be written

$$Pv_o = RTk + JM_o \frac{dQ}{dw} \dots \dots \dots (7)$$

Differentiating this with respect to T at constant volume (or concentration)—

$$\frac{\partial(Pv_o)}{\partial T} = Rk$$

For any given solution  $v_o$  may be regarded as independent of temperature, and we get

$$\left( \frac{\partial P}{\partial T} \right)_v = \frac{Rk}{v_o} = \text{constant.} \dots \dots \dots (8)$$

This result is quite analogous to the result obtained by

\*Zeit. Ph. Chem. 10, p. 92, 1892.

Ramsay and Young,\* that for a gas or liquid at constant volume the pressure may be represented by an equation of the form  $p = bT - a$  where  $b$  and  $a$  are constants. From this follows  $\left(\frac{\delta p}{\delta T}\right)_v = b = \text{constant}$ . The same result follows from Van der Waals' equation.

Equation 8 shows that the osmotic pressure may decrease when the temperature rises, or  $\left(\frac{\delta P}{\delta T}\right)_v$  may be negative. The sign of  $\frac{\delta P}{\delta T}$  is the same as that of  $k$ , which depends chiefly, as equation 4 shows, on the sign and magnitude of  $\frac{dQ}{dw}$ .  $k$  will be  $-$  when  $\frac{dQ}{dw}$  is  $+$ , and the sum of the terms containing  $c$  and  $\frac{dQ}{dw}$  in equation 4 is greater than the term containing  $w_0$ .

(c) If we put from equation 8

$$Rk = v_0 \left(\frac{\delta P}{\delta T}\right)_v \quad \text{in equation 7.}$$

it becomes

$$Pv_0 = Tv_0 \left(\frac{\delta P}{\delta T}\right)_v + JM_0 \frac{dQ}{dw}$$

from which

$$\left(\frac{\delta P}{\delta T}\right)_v = \frac{P}{T} - \frac{JM_0}{Tv_0} \frac{dQ}{dw}$$

This last equation becomes, when  $\frac{dQ}{dw} = 0$ .

$$\left(\frac{\delta P}{\delta T}\right)_v = \frac{P}{T}$$

That is at constant volume the osmotic pressure of a solution is proportional to the absolute temperature when the heat of dilution of the solution is zero. This result was obtained by Van't Hoff. (*loc. cit.* p. 11).

---

\* *Phil. Mag.* (5) 23, 435, 1887.

*Connection between Osmotic Pressure and the Concentration of the Solution.*

The equations obtained so far are quite general, and apply to solutions of any substance in any solvent, and show how the freezing point, vapour pressure, heat of dilution and osmotic pressure of a solution are connected among themselves and how they are affected by changes of temperature. The effect of a change of concentration (that is of the volume of solution which contains a gram molecule of the dissolved substance) has not yet been considered. Consider the simple case of a dissolved body consisting of only one kind of molecules, the nature of which is not affected by dilution. That is no dissociation of more complex molecules into more simple ones, and no chemical action is to take place on diluting the solution. In these circumstances suppose the solution consists of  $n$  gr. mols. of the solvent to 1 gr. mol. of the dissolved body. From equation 7 we have

$$Pnv_0 = RTnk + JM_0 n \frac{dQ}{dw}.$$

This equation is very similar to Van der Waals' well-known equation connecting pressure, temperature, and volume of a gas or liquid.

To make this clear, consider a quantity of a solution (or of a gas or vapour) in a cylinder which is closed by a piston, the pressure on which just balances the osmotic pressure of the solution (or the pressure of the gas). In case of a solution the piston must be permeable for the solvent, but not for the dissolved substance. The whole arrangement is kept at temperature  $T$ .

Allow the piston to rise so that  $dw$  gram. of solvent is added to the solution, increasing its volume by  $K \frac{dw}{\Delta_0} = dV$ . In the case of the gas let the volume simply increase by  $\alpha V$ .

The osmotic pressure of the solution being  $P$ , and the pressure of the gas  $p$ .

Then in both cases, in order to keep the temperature constant, a certain amount of heat must be added, which is the equivalent of the external and internal work done by the solution (or gas) in expanding. For the solution the work done is  $PK\frac{dw}{\Delta_o} - JdQ$  where  $dQ$  is the heat evolved on adding  $dw$  gr. solvent to the solution without doing external work.

For the gas or vapour the work done is according to Van der Waals  $p dV + \frac{a}{V^2} dV$

The heat of dilution evidently represents the internal work done in the expansion.

According to Van der Waals we have

$$p dV + \frac{a}{V^2} dV = \frac{RT}{V-b} dV$$

Assuming that a similar equation is true for the sum of external and internal work done when a solution expands, we get

$$PK\frac{dw}{\Delta_o} - JdQ = \frac{RT}{V-b} \cdot \frac{Kdw}{\Delta_o},$$

or

$$P(V-b) - J\frac{dQ}{dw} \frac{\Delta_o}{K}(V-b) = RT \quad \dots \quad (10)$$

As  $R$  is the gas constant for 1 gr. mol. of substance,  $V$  must be taken also as the volume in which a gram mol. is contained.

Compare equation (10) with (9), viz. :—

$$Pnv_o - J\frac{dQ}{dw} M_o n = RTnk \quad \dots \quad (9)$$

$nv_o$  is the volume by which the solution diminishes when  $n$  gr. mols. of solvent are withdrawn from it without changing its concentration, it may, therefore, be regarded as the

volume occupied in the solution by the solvent.  $V$  is the volume of  $n$  gr. mols. solvent + 1 gr. mol. dissolved body. We have, accordingly,

$$V - nv_0 = b,$$

where  $b$  is the volume in the solution of the dissolved substance (for 1 gram molecule).

We get, therefore,  $(V - b) = nv_0$ .

We have also  $\frac{\Delta_0}{K} = \frac{M_0}{v_0}$ ,

putting these values into equation (10), it becomes

$$Pnv_0 - JM_0n \frac{dQ}{dw} = RT.$$

By comparing this equation (which is obtained on the assumption that an equation of the same form as that of Van der Waals holds good for solutions) with (9), it is evident that if the equation connecting osmotic pressure, volume, and temperature of a solution is really of the same form as Van der Waals' equation, we must have

$$kn = \pm 1.$$

The sign will depend on the sign of  $k$ .

The equation for the osmotic pressure of a solution may, then, be written

$$P(V - b) = \pm RT + JnM_0 \frac{dQ}{dw} \quad \dots \quad (11)$$

The meaning of  $RT$  having the  $-$  sign is, that when the solution is diluted in a reversible way, the maximum of external (osmotic) work being done, there is still heat evolved by the system. This is a case which, so far as I know, never occurs with gases.

The experimental material necessary to test the truth of the expression  $k = \frac{1}{n}$  is unfortunately not in existence.

The only substance for which I have been able to find sufficient determinations of the freezing point and of the

heat of dilution is alcohol, and even in this case the determinations of the heat of dilution (Dupré and Page\*) are not sufficiently numerous to allow of the values of  $\frac{dQ}{dw}$  being calculated with any approach to accuracy. The following table contains, however, the numbers which I have obtained. The determinations of the freezing point are Raoult's.†

| Grams alcohol<br>to 100 gr. H <sub>2</sub> O. | F.    | $k$<br>highest. | $k$<br>lowest. | $\frac{1}{n}$ |
|-----------------------------------------------|-------|-----------------|----------------|---------------|
| 15·19                                         | 267·2 | +·0065          | +·0139         | ·0595         |
| 19·56                                         | 265·2 | -·0765          | -·0147         | ·0765         |
| 24·70                                         | 262·4 | -·1254          | -·0454         | ·0967         |
| 29·15                                         | 260·2 | ·1711           | ·0890          | ·1141         |
| 40·68                                         | 254·1 | ·1851           | ·1241          | ·1591         |
| 51·02                                         | 248·7 | ·1985           | ·1545          | ·1996         |
| 59·66                                         | 244·8 | ·2405           | ·1365          | ·2335         |
| 70·15                                         | 240·9 | ·3553           | ·1788          | ·2744         |

I could find no interpolation formula which would represent Dupré and Page's numbers for the heat of solution of alcohol. I, therefore, calculated  $\frac{dQ}{dw}$  from three different curves. Owing to the small number of determinations (there were only five which I could use) the curves could not be drawn accurately, and, therefore, the values of  $\frac{dQ}{dw}$  obtained do not agree with each other. The value of  $k$  has, therefore, been calculated by equation (4), using the highest and lowest values of  $\frac{dQ}{dw}$  found, and as will be seen the value of  $\frac{1}{n}$  lies between these limits, except for the most dilute solution.

It may be remarked that in this case (*viz.*, alcohol dissolved in water)  $k$  has the negative sign.

\* *Phil. Trans.*, 1869, p. 591.

† *Ann. Chim. Phys.* (5) 20, p. 220. 1880.

The equation (11) includes the equations which have already been given by Van't Hoff for the case that  $\frac{dQ}{dw} = 0$ . In this case it is easy to see from (4) that  $k$  is positive, and therefore, equation (11) becomes

$$P(V - b) = RT.$$

If the solutions considered are dilute,—that is  $V$  large compared with  $b$ ,—this may be written—

$$PV = RT.$$

Again (11) may be written in the form

$$Pnv_o = \pm RT + JnM_o \frac{dQ}{dw}$$

or for

$$\frac{dQ}{dw} = 0, \text{ this becomes } \frac{Pv_o}{RT} = \frac{1}{n}.$$

And from (1)

$$\frac{Pv_o}{RT} = \log \frac{p_o}{p},$$

accordingly

$$\log \frac{p_o}{p} = \frac{1}{n},$$

or for dilute solutions

$$\frac{p_o - p}{p_o} = \frac{1}{n}$$

which is the well-known equation of Raoult. It was also obtained in this form by Planck,\* in 1887.

The expression for the molecular depression of the freezing point of a solution follows from equation 4. Putting  $(T_o - F) = t$

$$k \frac{n}{n} = \frac{J}{R} \left\{ w_o \frac{t}{T_o F} - \frac{c}{2F^2} - \frac{M_o}{F} \frac{dQ}{dw} \right\}$$

$\frac{t}{g}M$  is called the molecular depression of the freezing point of a solution, when  $t =$  the depression produced by  $g$  grams

\* *Wied. Ann.* 32, p. 502. 1887.

dissolved substance in 100 gr. solvent, and  $M$  = molecular weight of the dissolved substance.

We have accordingly  $n = \frac{100 M}{g M_0}$  and writing  $\frac{w_0}{M_0} = W =$  heat of fusion for 1 gr. solvent and  $\frac{c}{M_0} = C =$  difference of the sp. heats of liquid and solid solvent, and also calling  $\frac{J}{R} = \frac{1}{2}$  we get

$$(kn) \cdot \frac{g}{Mt} = \frac{1}{\cdot 02} \left[ \frac{W}{T_0 F} - \frac{C}{2} \frac{t}{F^2} - \frac{1}{Ft} \frac{dQ}{dw} \right]$$

In the special case when  $\frac{dQ}{dw} = 0$  and  $kn = 1$  this equation becomes

$$\frac{g}{Mt} = \frac{1}{\cdot 02} \left( \frac{W}{T_0 F} - \frac{C}{2} \frac{t}{F^2} \right)$$

and when the solutions are dilute this may be written

$$\frac{Mt}{g} = \frac{\cdot 02 T_0^2}{W}$$

This is the expression for the molecular depression of the freezing point, which was first given by Van't Hoff in 1885.\*

---

\* Van't Hoff, *loc. cit.* p. 47.



**On the Treatment of Sewage with Basic Per-Salts of Iron under varying conditions.** By Harry Grimshaw, F.C.S.

*(Received February 6th, 1894.)*

The object of the present paper is to present the conclusions arrived at from the treatment on the working scale of large volumes of the sewage of a manufacturing town in relation to the chemical problem involved, and the practical conditions under which the trials were carried out.

In a paper read before the Manchester Literary and Philosophical Society on May 4th, 1890, and printed in the *Memoirs* of the Society, the results of the treatment for a period of a month, of 100,000 gallons per day, of the Salford Sewage are given, and the further results which are given in the present paper are from the application of the Basic Persulphate of Iron to the whole of the sewage of that town.

The preliminary experiments upon the 100,000 gallons per day were conducted in a set of experimental tanks at the Salford Sewage Works, which are constructed to contain exactly one hundredth part of the volume held by the main tanks, which are used to treat an average of nearly 10 million gallons per day of 24 hours.

The minimum daily flow of the Salford Sewage is about six million gallons upon the Sunday when, owing to the manufactories not being at work, the sewage approximates to that of an ordinary residential town. The maximum is some thirteen or fourteen millions during the middle of the week and during wet weather. From about 6 a.m. on the

Monday to about 6 p.m. on the Saturday the waste water from manufactories amounts to nearly one half of the total volume of sewage.

The general results of the preliminary experiments are indicated in the following table, showing the results of treatment during the month of December, 1892.

TABLE I.

*Salford Sewage and Effluents, after treatment with Basic Persulphate of Iron. 100,000 gallons treated daily with 15 grains per gallon. Results expressed in parts per 100,000 of Albumenoid Ammonia.*

| Date<br>1892. | (1)<br>Crude<br>Sewage<br>12 hours<br>settling. | (2)<br>Effluent<br>Unfiltered. | (3)<br>Effluent<br>Filtered<br>Sand. | (4)<br>Effluent<br>Filtered<br>Ozonite. | Per Cent.<br>of<br>Purifica-<br>tion.<br>(2) | Per Cent.<br>of<br>Purifica-<br>tion.<br>(3) | Per Cent.<br>of<br>Purifica-<br>tion.<br>(4) |
|---------------|-------------------------------------------------|--------------------------------|--------------------------------------|-----------------------------------------|----------------------------------------------|----------------------------------------------|----------------------------------------------|
| Nov. 28       | 1'00                                            | 0'40                           | 0'30                                 | ...                                     | 60                                           | 70                                           | ...                                          |
| " 29          | 0'80                                            | '42                            | '35                                  | ...                                     | 47                                           | 55                                           | ...                                          |
| " 30          | 0'75                                            | '40                            | '29                                  | ...                                     | 47                                           | 61                                           | ...                                          |
| Dec. 1        | '75                                             | '31                            | '22                                  | ...                                     | 59                                           | 70                                           | ...                                          |
| " 2           | '56                                             | '28                            | '16                                  | ...                                     | 50                                           | 73                                           | ...                                          |
| " 3           | '90                                             | '28                            | '19                                  | ...                                     | 69                                           | 89                                           | ...                                          |
| " 4           | '85                                             | '35                            | '25                                  | ...                                     | 60                                           | 70                                           | ...                                          |
| " 5           | '60                                             | '30                            | '17                                  | ...                                     | 50                                           | 71                                           | ...                                          |
| " 6           | '71                                             | '30                            | '17                                  | ...                                     | 57                                           | 76                                           | ...                                          |
| " 7           | '75                                             | '32                            | '22                                  | ...                                     | 56                                           | 71                                           | ...                                          |
| " 8           | '60                                             | '30                            | '15                                  | ...                                     | 50                                           | 75                                           | ...                                          |
| " 9           | '65                                             | '30                            | '16                                  | ...                                     | 5                                            | 75                                           | ...                                          |
| " 11          | '59                                             | '28                            | '15                                  | ...                                     | 53                                           | 73                                           | ...                                          |
| " 12          | '65                                             | '30                            | '18                                  | ...                                     | 54                                           | 72                                           | ...                                          |
| " 13          | '70                                             | '30                            | '21                                  | 0'18                                    | 57                                           | 73                                           | 74                                           |
| " 14          | '51                                             | '25                            | '19                                  | 0'135                                   | 50                                           | 64                                           | 73                                           |
| " 15          | '51                                             | '25                            | '19                                  | '16                                     | 50                                           | 62                                           | 69                                           |
| " 16          | '52                                             | '26                            | '20                                  | '16                                     | 50                                           | 61                                           | 72                                           |
| " 17          | '62                                             | '28                            | '19                                  | '15                                     | 55                                           | 70                                           | 75                                           |
| " 20          | '51                                             | '20                            | '19                                  | '145                                    | 60                                           | 64                                           | 71                                           |
| " 21          | '60                                             | '26                            | '19                                  | '15                                     | 56                                           | 70                                           | 75                                           |
| " 22          | '60                                             | '26                            | '21                                  | '18                                     | 56                                           | 65                                           | 71                                           |
| " 23          | '57                                             | '24                            | '18                                  | '16                                     | 60                                           | 68                                           | 72                                           |
| " 24          | '60                                             | '23                            | '17                                  | '14                                     | 60                                           | 70                                           | 76                                           |
| Average       | 0'63                                            | 0'29                           | 0'20                                 | 0'15                                    | 55                                           | 68                                           | 73                                           |

NOTE.—The Crude Sewage, column No. 1, was allowed to settle 12 hours before analysis.

The Effluents, Nos. 2, 3, and 4 were shaken up before analysis.

During these experiments the sewage was of what may be called an average impurity, the Albumenoid Ammonia, which is one of the chief indicators of this, being 0.63 parts per 100,000 in the sewage settled in 12 hours, or, in other words, the soluble albumenoid matter in the sewage yielded 0.63 parts of ammonia per 100,000, or 6.3 parts per million.

The sewage of this character was treated with an amount of the solution of Basic Persulphate of Iron of 100° Twaddle (or sp. gr. 1.5), varying from 15 to 20 grains per gallon of sewage, or 20 to 25 cwt. per million gallons. In order to secure the best results with a sewage of this nature, lime at the rate of 5 to 10 cwt. per million gallons was also added.

The average results of the one month's trial in these experimental tanks, as shown in Table I., was an effluent by precipitation only containing 0.29 parts per 100,000 of albumenoid ammonia, which was further reduced by filtration to 0.15.

The quantity of iron salt used, in the trial, was to be restricted to one ton of the standard strength (100° Twaddle, or 1.5 sp. gr.) to the million gallons of sewage. This was about the quantity used in the smaller trials previously alluded to, but it appeared very problematical whether, in very much greater space and with the greatly increased volume involved in dealing with the whole sewage, it would be practicable to work to such a nice point in regard to quantities.

Further, the question presented itself, whether the greater rate of flow, ten to one, in the main tanks, as compared to that in the experimental tanks, would not require a greater proportionate amount of precipitate to add weight to the flocculent particles.

However the attempt was made, in the first place, to ascertain whether the proposed quantity of one ton per million gallons, together with about 5 cwt. of lime, would

efficiently purify, under the conditions of flow, &c., in the main tanks, and the trial was commenced on Monday, June 12th, 1890.

Careful inspection of the results during the next day's working made it evident that the quantities of precipitants were not sufficient to produce a good result, and although during the next day or two every possible variation was made within the limit of quantity desired by the Salford Committee, by allowing for the known rate of flow and varying composition of the sewage during different periods of the 24 hours, these variations all tended to show that the quantities of precipitant whilst quite sufficient for the night sewage, were inadequate for the kind of sewage prevalent during the working day.

That this was the case is shown by the following table of the amount and percentage of albumenoids removed on the first three days' working. The effluent showed by its turbid appearance that it was not completely precipitated.

TABLE II.

*Result of treatment of Salford Sewage, about 10,000,000 gallons per day, with Basic Persulphate of Iron at the rate of one ton per million gallons, together with 5 cwt. of lime per million gallons. Albumenoid Ammonia per 100,000 percentage of purification is on settled Sewage, and represents % of soluble impurity removed.*

| 1893.   | Crude Sewage. |          | Effluent. |                    | Effluent filtered. |                    |
|---------|---------------|----------|-----------|--------------------|--------------------|--------------------|
|         | Shaken.       | Settled. | Alb. Amm. | % of purification. | Alb. Amm.          | % of purification. |
| June 13 | 1'60          | 0'71     | 0'58      | 18                 | ...                | ...                |
| * " "   | ...           | '71      | '49       | 30                 | ...                | ...                |
| * " 14  | ...           | '54      | '48       | 11                 | 0'1                | 31                 |
| * " "   | ...           | '54      | '40       | 26                 | ...                | ...                |
| * " 15  | ...           | '51      | '41       | 20                 | 0'18               | 63                 |
| * " "   | ...           | '51      | '38       | 25                 | ...                | ...                |

\* Sewage after precipitation collected in special tank, and allowed to subside before running off.

It was therefore arranged to try the effect of a larger quantity of the Iron Salt on the 19th, 20th, and 21st of June.

During this experiment the period of trial was 56 hours. During this period 33 tons of basic persulphate of iron and  $9\frac{1}{2}$  tons of lime were used. The quantity of sewage passed through the tanks was about 23 million gallons during the 56 hours. Per million gallons of sewage, therefore, was used  $28\frac{2}{3}$  cwts. of iron salt, and 8 cwt. of quick lime. The iron salt is reckoned as a solution of basic persulphate of 1.5 sp. gr., the quick lime contained about 78 per cent. of calcium oxide (CaO.).

The effect of the increase of precipitant was most marked. The effluent passing over the sill of the last tank, instead of being turbid was exceedingly clear, although often containing some particles of flocculent matter carried over by the too rapid flow of the sewage through the tanks. This effect is seen by comparing the percentage of soluble impurities removed as shown in Tables 3 and 4.

TABLE III.

*Result of treatment of Salford sewage, about 10,000,000 gallons per day, with Basic Persulphate of Iron, at the rate of 29 cwt. per million gallons, together with 8 cwt. of lime per million gallons.*

| 1893.   | Crude Sewage.                 |                                | Effluent unfiltered.   |                    | Effluent filtered (sand). |                    |
|---------|-------------------------------|--------------------------------|------------------------|--------------------|---------------------------|--------------------|
|         | Shaken Alb. Amm. per 100,000. | Settled Alb. Amm. per 100,000. | Alb. Amm. per 100,000. | % of purification. | Alb. Amm. per 100,000.    | % of purification. |
| June 19 | 1.5                           | 0.8                            | 0.38                   | 52                 | 0.24                      | 70                 |
| „ 20    | 1.6                           | 0.8                            | 0.35                   | 56                 | 0.28                      | 68                 |
| „ 21    | 1.4                           | 0.65                           | 0.35                   | 46                 | 0.24                      | 65                 |

The method of sampling for the test was as follows :— A sample of the sewage and of the effluent was taken every hour, day and night. The samples were at the end of the

24 hours mixed together in a large stoneware vessel, and portions of the whole were taken for analysis. In some cases the day and night samples were kept separate, but the real period of trial, three days, was too short to permit much comparison in this respect.

The following table gives the results of the analyses :—

TABLE IV.

*Results of treatment of Salford sewage with Basic Persulphate of Iron together with lime. Purification from soluble Albumenoid Ammonia.*

|         | Crude Sewage. |                                | Effluent unfiltered.   |                    | Effluent filtered.     |                    |
|---------|---------------|--------------------------------|------------------------|--------------------|------------------------|--------------------|
|         | Shaken.       | Settled Alb. Amm. per 100,000. | Alb. Amm. per 100,000. | % of purification. | Alb. Amm. per 100,000. | % of purification. |
| June 13 | ...           | 0·88                           | 0·66                   | 21                 | ...                    | ...                |
| „ 14    | ...           | 0·6                            | 0·48                   | 20                 | ...                    | ...                |
| „ 15    | ...           | 0·6                            | 0·40                   | 33                 | ...                    | ...                |
| June 19 | ...           | 0·64                           | 0·36                   | 43                 | ...                    | ...                |
| „ 20    | ...           | 0·80                           | 0·36                   | 55                 | ...                    | ..                 |
| „ 21    | ...           | 0·84                           | 0·38                   | 54                 | ...                    | 83                 |

The above results are from the *day* samples of sewage, and with this taken into account show a close agreement with my own figures in Tables 3 and 4.

*Remarks upon the General Results of the Trials.*—The most interesting feature is found in the comparison of the results obtained in the small experiments on 100,000 gallons per day, and those obtained when applying the same treatment to the whole quantity of sewage, this latter in total amount treated being 85½ million gallons in about 8 days.

The two conditions which in the two experiments were essentially different are :—(1.) In June, 1893, after the long drought of this very exceptional year, the Salford sewage was some 25 per cent. more impure than usual. (2.) The rate of flow over the main tanks of the Salford sewage

works is ten times as great as that of the experimental tanks, the former being 80 feet wide to take 10,000,000 gallons per day, and the latter 8 feet wide to take 100,000 gallons.

The result of this rapidity of flow is shown by the percentage of purification in the filtered and unfiltered effluents in Table 4 compared with those in Table I. The less perfect subsidence affects the effluent as it runs from the tanks, but does not cause any material difference in the percentage of purification after filtration, which arrests any flocculent matters carried away by the too rapid flow.

A third condition makes its appearance as a factor in the practical application of the precipitant, and this is the continuously varying nature of the sewage of an industrial town. In the smaller experiments it was possible to cope with, to some extent, the almost hourly variations of the nature of the sewage, by attention to the supply of precipitant, but on the large scale this becomes much more impracticable, and whilst such considerable variations as are found between the day sewage and the night sewage may be fairly easily met, the only way to secure a uniformly good effluent during the day is to add a sufficient quantity of precipitant to purify the sewage at its worst. This is especially the case if the attempt is being made to work without filters or land to receive the tank effluent.

With regard to the filtration of the effluents from the tanks, it may be remarked that this was through about three feet of sand and gravel, or through the same depth of ordinary cinders and clinkers, the result being much the same in either case. It is improbable that the filters effected anything more than a straining from the flocculent particles, as the rate of flow was too rapid for any appreciable oxidation to take place.

There is much to be said in favour of the use of some straining medium after precipitation and subsidence as a

safeguard against sudden variations in the working of the process caused either by inattention of those in charge, or by actual change in the nature of the sewage.

The time available for the experiments was not, unfortunately, sufficient to fully determine whether the increase of amount of precipitating material, or the addition of a filtering or straining medium, would be the most economical with a due regard to efficiency.

A short period of experiment, however, would evidently settle this point, and a future opportunity, either at Salford or elsewhere, will no doubt present itself, in which case I should be pleased to place the results before the Society.

---



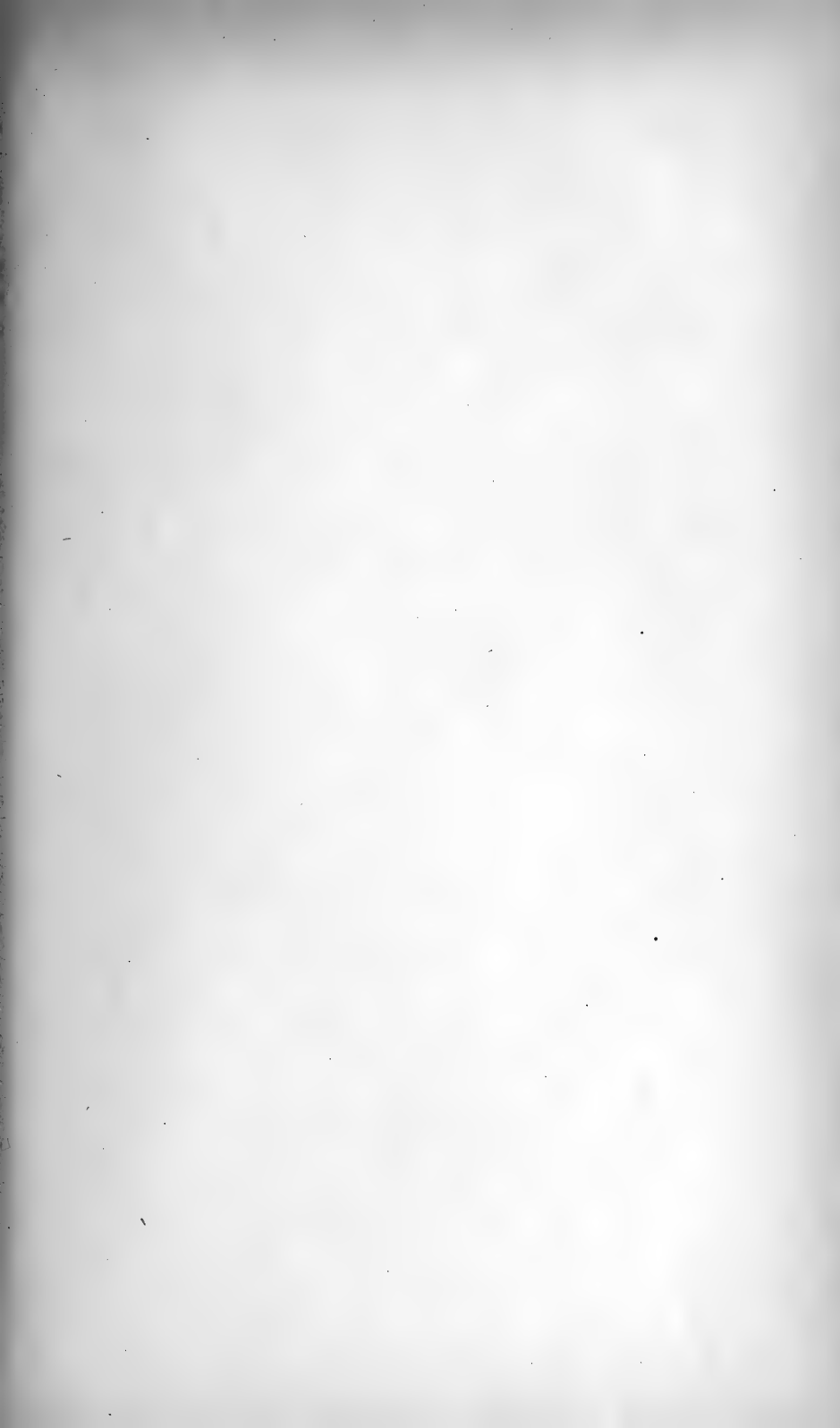

Throw of  
Ballistic Galvanometer

100

50

50

100

Magnetization Curve of Field Magnets.

Exciting Current  
in Amperes

5

4

3

2

1

0

1

2

3

4

5



EMF Curves Open Circuit

Volts.

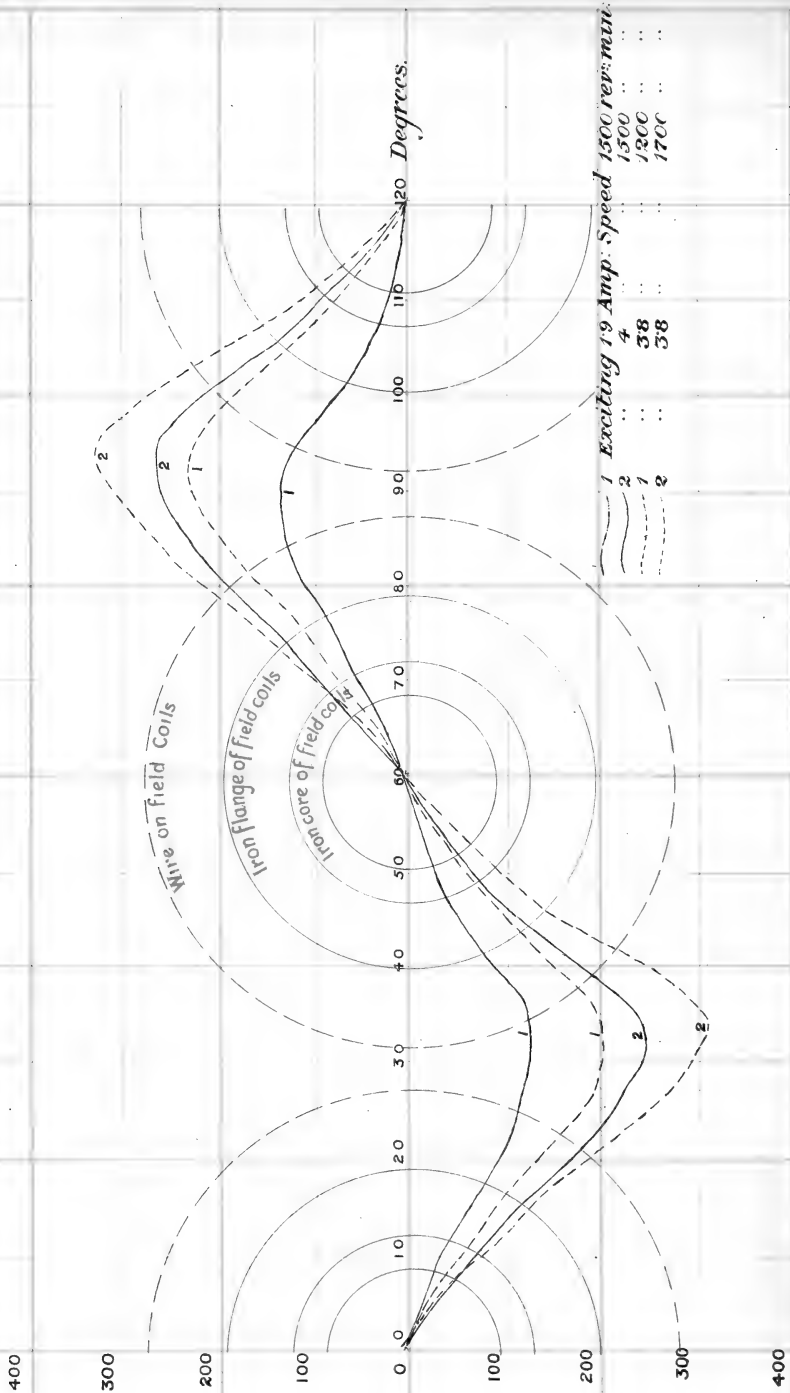



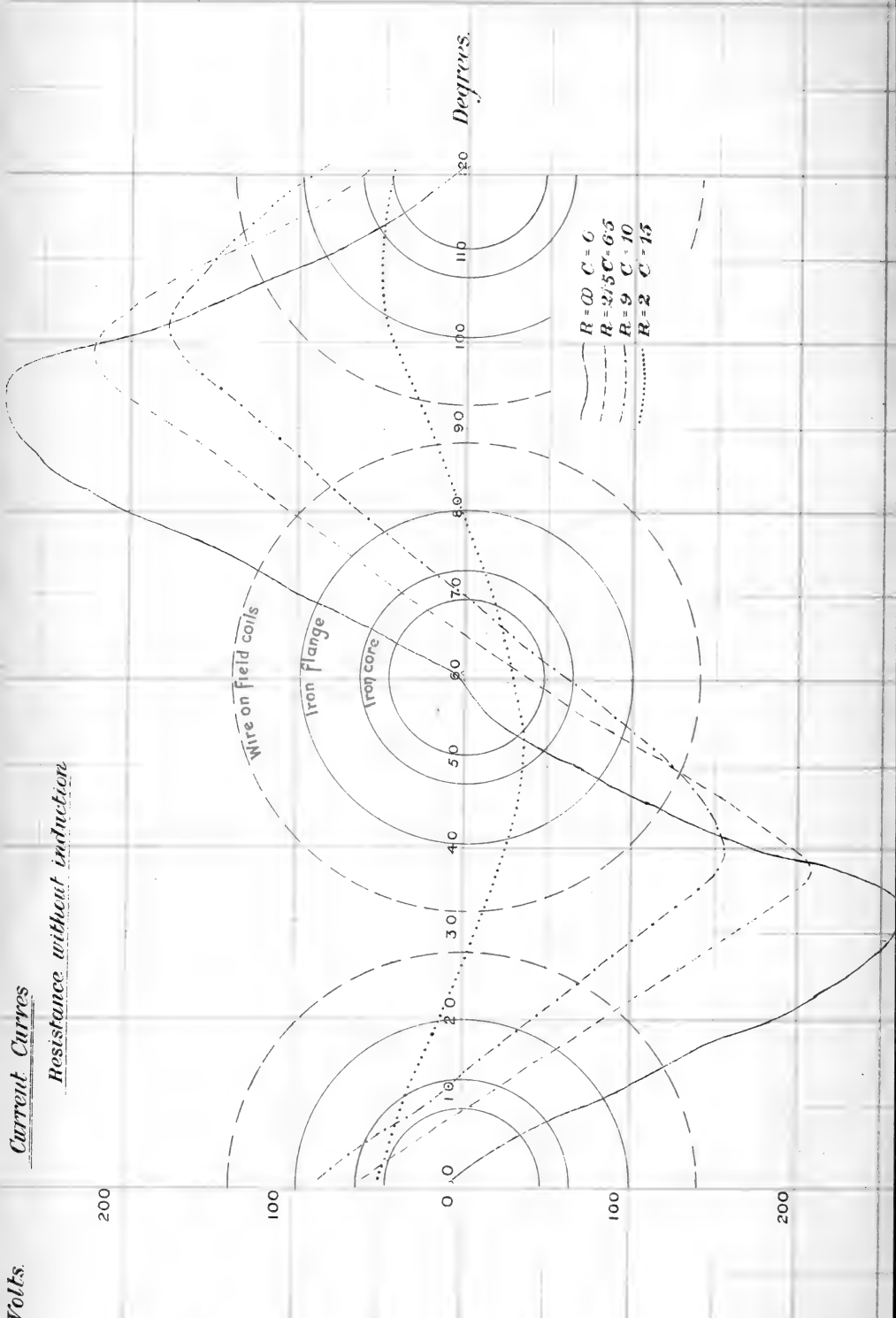



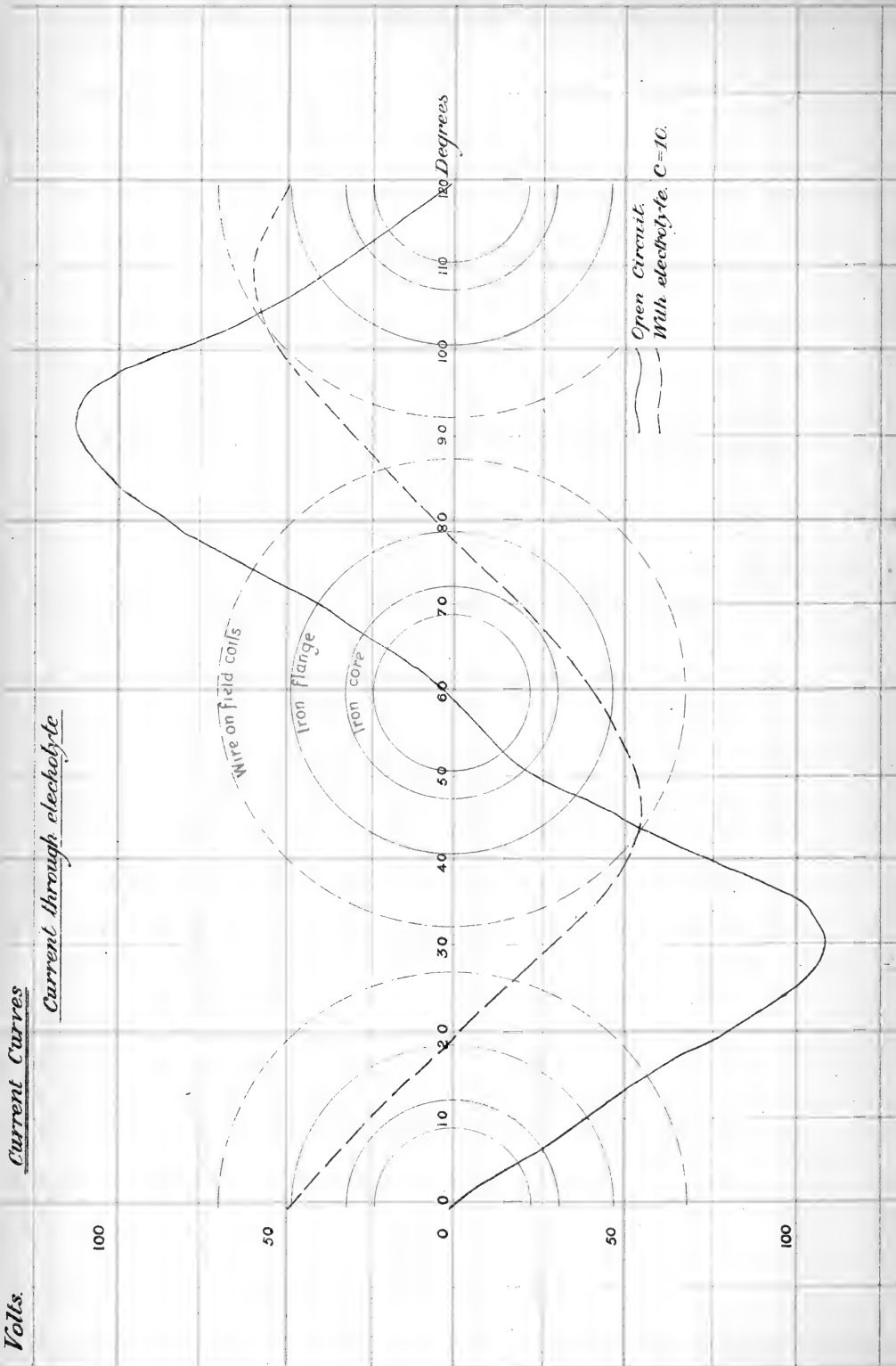





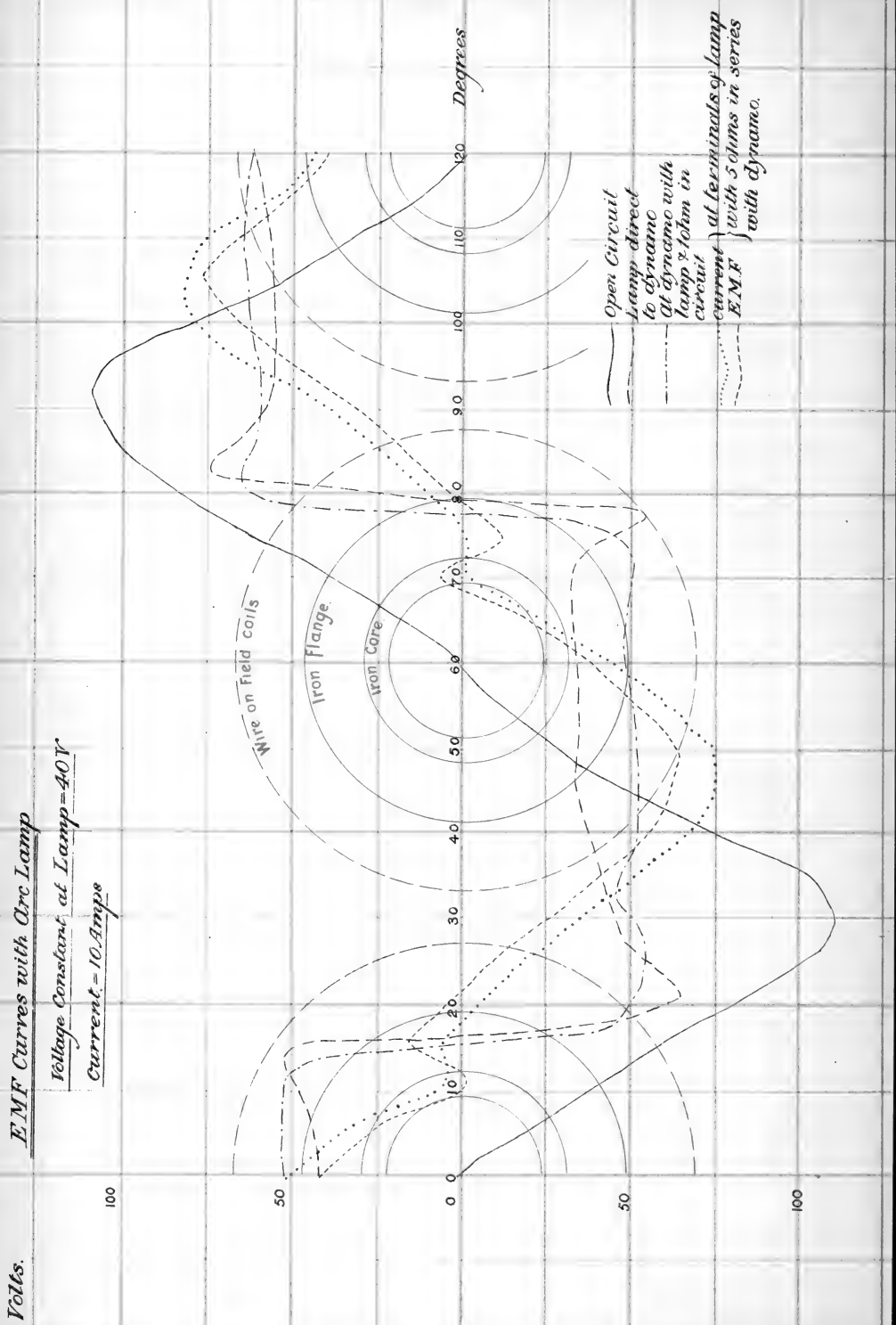



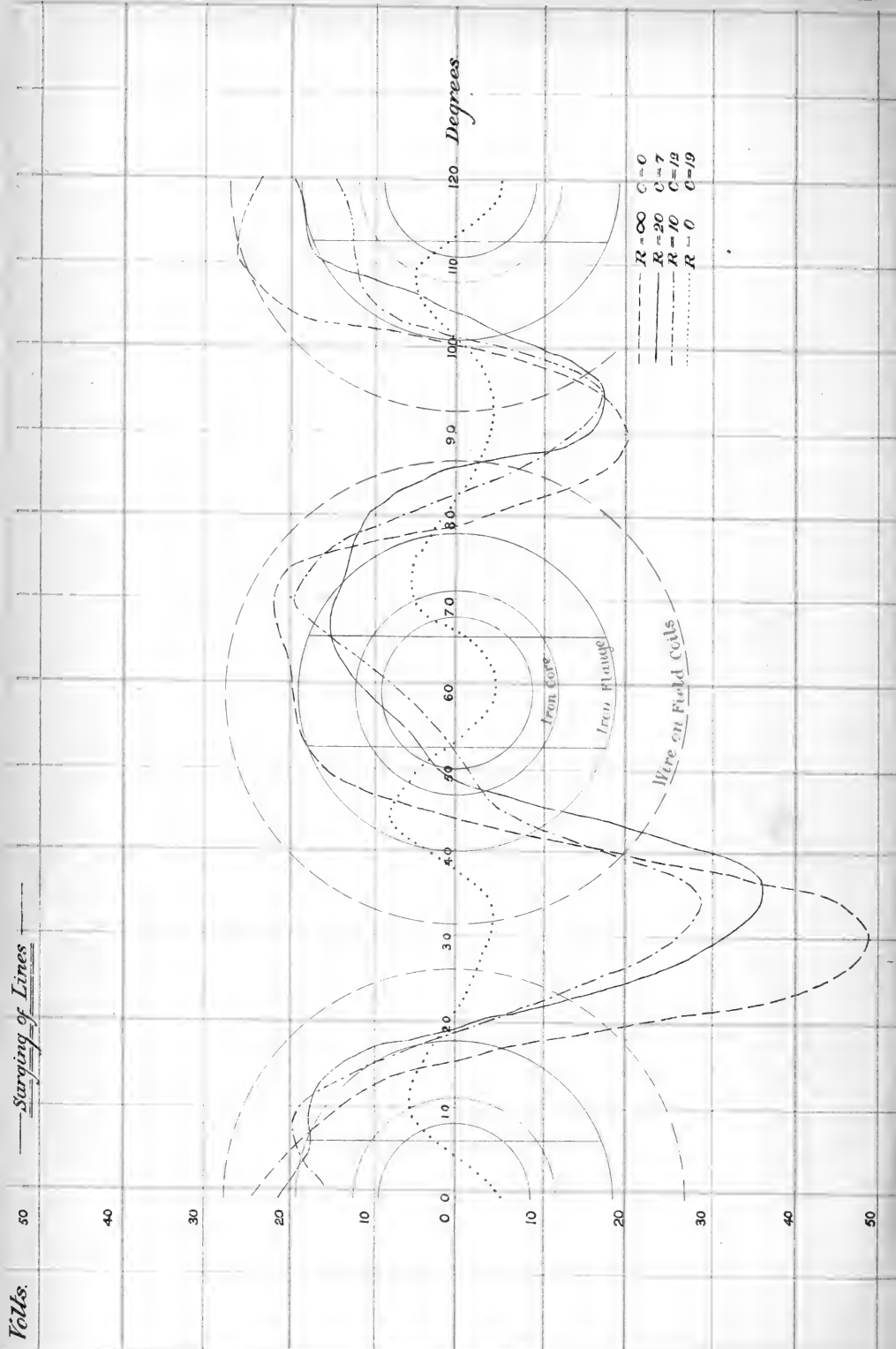

An Analysis of the Electro-Motive Force and Current Curves of a Wilde Alternator, under various conditions. By Julius Frith, Heginbottom Physical Scholar of the Owens College. Communicated by Arthur Schuster, Ph.D., F.R.S.

*(Received March 20th, 1894.)*

These experiments were undertaken with a view to finding out how far the actual behaviour of an alternating-current dynamo follows the laws deduced for it from the theory of the alternator ; and if the electro-motive force and current deviate from the theoretical sine curve, how many terms of the Fourier's expression should be taken into

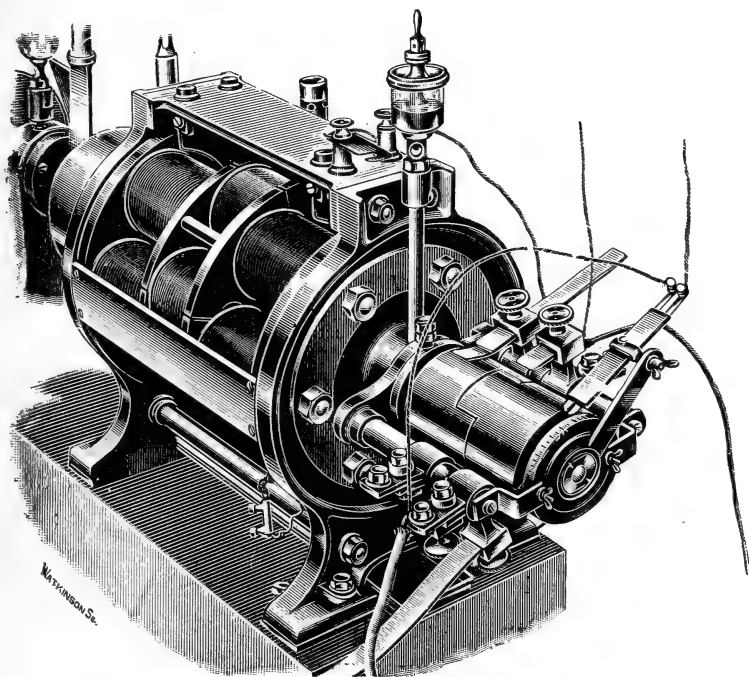

account. They have led to the conclusion that, for the case of an alternator whose armature contains iron, at least three terms of the Fourier's expression must be considered,

but most especially the third, the second being in most cases comparatively small.

*Description of Machine.*—The Wilde alternator used consists of two crowns of cast-iron facing each other; from the internal surfaces of these crowns project the fixed field coils, six in number, on each side. These are bobbins of wire wound on iron cores. The armature revolves between these, and consists of six similar bobbins on tubular iron cores, held in position between two discs of brass which are keyed on to the shaft. The six coils of the armature are connected in series to the commutator.

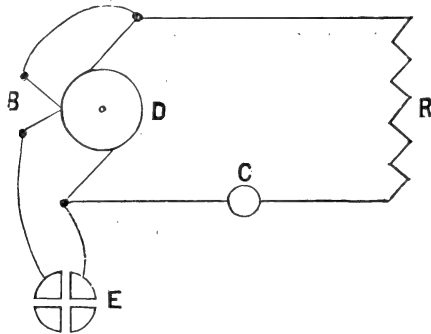

*Fig. 1.*

D = Wilde alternator.

R = Resistance, without self-induction.

C = Ammeter.

E = Electrometer.

B = Two insulated brushes bearing on the ebonite disc which carries the copper contact piece.

*Principle of Intermittent Contact.*—On the end of the shaft beyond the commutator is keyed an ebonite disc; in a slot cut in this, about  $\frac{1}{8}$  inch wide, a piece of copper is fixed, and turned down flush with the ebonite. On this disc bear two insulated brushes, side by side; it will be seen that at one instant in every revolution these two brushes are connected together, while remaining insulated from the rest of the machine. If one of these brushes is connected to one pole of the dynamo, and wires are

taken from the other brush and the other pole of the machine to an electrometer, the electrometer becomes connected to the poles of the dynamo, at one definite point in the revolution of the armature. This point is known, and can be altered by the arm which carries the two insulated brushes moving round a fixed divided circle.

*Method of obtaining Current Curves.*—This arrangement would give the E.M.F. curves at the terminals of the machine. To obtain the current curves, the fact is made use of that the current in a non-inductive resistance is in phase with, and proportional to, the E.M.F. at the terminals of the resistance. Therefore, if the electrometer can be connected through the same intermittent contact apparatus to the terminals of an ohmic resistance, the form of the current curve can be obtained.

*The Electrometer.*—The Electrometer used was Mascart's quadrant, and consisted of an aluminium needle suspended in the quadrant by a silver wire; to the needle was attached the mirror and a damping vane dipping into oil. Each opposite pair of quadrants was connected to the ends of a water battery of 48, 96, or 144 cells; the middle of the battery was always connected to the frame of the instrument. The wires from the intermittent contact apparatus were connected respectively to the frame, and to the needle by means of the silver wire suspension.

With this arrangement of the electrometer, the deflection is directly proportional to the difference of potential between the needle and the frame.

The constant of the instrument was found by means of a battery of Clark's cells.

With 24 water cells 1 scale div. = .87 volts.

„ 48 „ „ = .43 „

„ 72 „ „ = .29 „

*Magnetization Curves of Field Magnets.*—To obtain the magnetization curve of the iron of the field magnets, a flat coil of 12 turns of wire was wound, and arranged so that it

could be suddenly withdrawn from between the field coils and the armature, when the latter was at rest with its coils in a line with the field coils. The ends of this coil were connected to a ballistic galvanometer and the kick observed for different values of the magnetizing current on suddenly withdrawing the coil. Curve I. (Plate III.) represents the results of these experiments.

*E.M.F. Curves Varying Speed and Exciting Current.*—Curve II. (Plate IV.) shows the E.M.F. curves at the terminals of the dynamo on open circuit, (1) keeping the speed constant and varying the exciting current, and (2) keeping the exciting current constant and varying the speed of the dynamo.

*Current Curves.*—Curve III. (Plate V.) shows the effect of taking current from the machine, the resistance coils through which the current passed being nearly without self-induction; the lag recorded being due to the self-induction of the armature.

If  $E$ , the impressed E.M.F., be of the form

$$E_0 \sin pt,$$

then in a circuit of self-induction  $L$  and resistance  $R$  the current is given by

$$C = \frac{E_0}{\sqrt{R^2 + p^2 L^2}} \sin(pt - a)$$

where

$$\tan a = \frac{Lp}{R}.$$

From the observations shown in Plate V. the equations to the curves are found by the method of least squares to be:

For the E.M.F. curve,  $R = \infty$

$$E = -229 \sin(\theta - 2^\circ) - 16.4 \sin(2\theta - 3^\circ) + 36 \sin(3\theta + 1^\circ).$$

For  $R = 21.5$ ,

$$C = -8.7 \sin(\theta - 20^\circ) - .14 \sin(2\theta + 84^\circ) + .34 \sin(3\theta + 33^\circ).$$

For  $R = 9$ ,

$$C = -16.4 \sin(\theta - 31^\circ) - .4 \sin(2\theta - 61^\circ) - 1.6 \sin(3\theta + 51^\circ)$$

For  $R = 2$ ,

$$C = -20.7 \sin(\theta - 64^\circ) - .7 \sin(2\theta - 20^\circ) - 1.9 \sin(3\theta + 12^\circ).$$



The lag in the first term of last three curves is  $22^\circ$ ,  $34^\circ$ , and  $66^\circ$  respectively. From the formula

$$\text{Tan } \theta = \frac{L \cdot p}{R}$$

where  $\theta$  = angle of lag

$$p = 2\pi n$$

$n$  = alternations per second

$L$  = self-induction

$R$  = total resistance in circuit

the self-induction may be calculated as follows:—

$$\tan 22^\circ = \cdot 4$$

$$\therefore L = \frac{\cdot 4 \times 21 \cdot 93}{2 \cdot \pi \cdot 75} = \cdot 0174 \text{ secohms.}$$

$$\tan 34^\circ = \cdot 67$$

$$\therefore L = \frac{\cdot 67 \times 9 \cdot 43}{2 \cdot \pi \cdot 75} = \cdot 0134 \quad ,,$$

$$\tan 66^\circ = 2 \cdot 25$$

$$\therefore L = \frac{2 \cdot 25 \times 2 \cdot 43}{2 \pi 75} = \cdot 0116 \quad ,,$$

These show that the self-induction of the armature decreased with the increase of magnetization of the iron in the cores. This agrees with the results of measurements of the self-induction carried on in the ordinary way with the machine at rest. These give,

$$L = \cdot 02 \text{ secohms ;}$$

with the fields excited,

$$L = \cdot 013 \text{ secohms.}$$

On taking power from the machine the irregularities die out of the curve, and it becomes first nearly straight from the maximum in one direction to the maximum in the other, and then gradually approaches the sine curve.

*Electrolyte.*—Next a copper-plating bath, consisting of two plates of copper 30cms.  $\times$  40cms., placed 100cms. apart in an acid solution of copper sulphate, was put in circuit, and a current of 10 ampères was passed through.

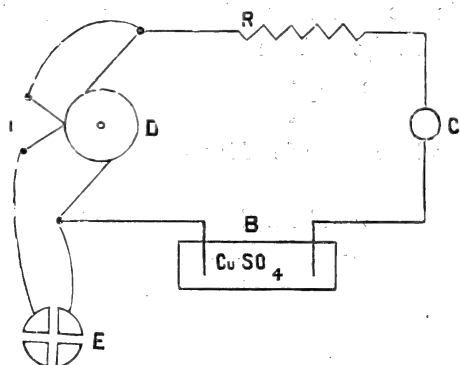

Fig. 2.

- I Intermittent contact.
- E Electrometer.
- D Alternator.
- B Copper bath.
- C Ammeter.
- R Resistance without self-induction.

A resistance of 4 ohms was placed in series with the bath, and the curve taken at the terminals of the dynamo.

On Plate VI. are also drawn the curve for 10 ampères passed through resistance, and the curve of the machine on open circuit.

Next an arc lamp was substituted for the copper bath. The potential at the terminals of the lamp was kept constant and equal to 40 volts.

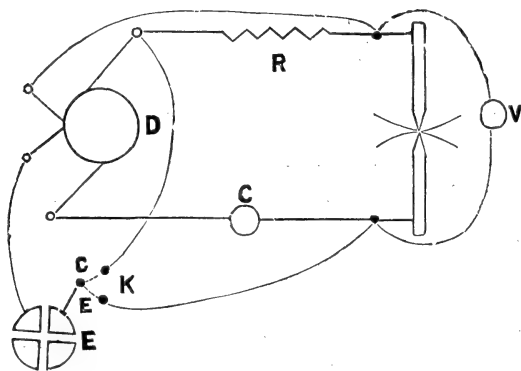

Fig. 3.

The Electrometer can be alternatively connected to the terminals of the lamp, for the E.M.F. curve, or to the terminals of a resistance of 5 ohms for the current curves. This is done by the key *k*.

The Lamp used was a simple hand regulating one, and therefore had no series coils and no self-induction.

Two curves were taken at the poles of the alternator, one with the lamp direct to the dynamo, the other with a resistance of 1 ohm in series.

On the same sheet, the current and E.M.F. curves of the lamp with 5 ohms in series are shown.

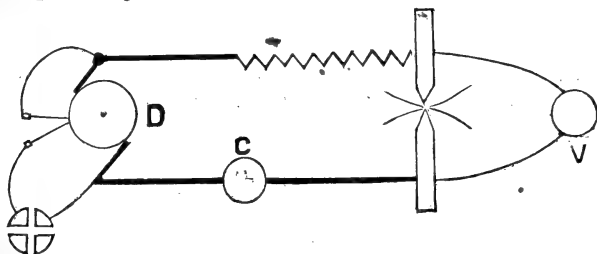

*Fig. 4.*

*Blondil.*—It is interesting to compare these curves with some obtained by the French electrician Blondil.—*The Electrician*, December 15, 1893. Some of these curves almost exactly agree with the ones drawn on Plate VII.

*Surging of Lines.*—Plate VIII. shows the surging of the lines of force of the field magnets. This was measured by fitting over one of the field coils a light wooden frame which carried 155 wires stretched radially across the face of the pole, in the air gap between the fields and the armature. The surging of the lines past these induced in them an E.M.F., which was measured in the usual way by the electrometer through the intermittent contact apparatus. The induced E.M.F. is proportional to the rate of motion of the magnetic field. This motion must in a large degree account for the deviation of the electro-motive force and current curves from simple sine curves.

On the primary structure of The Stem of *Calamites*.  
By Thomas Hick, B.A., B.Sc., Assistant Lecturer  
in Botany, Owens College, Manchester. Communicated by F. E. Weiss, B.Sc., Professor of Botany  
in the Owens College.

(Received February 20th, 1894.)

Though a great deal has been written on the anatomy of the Stem of *Calamites*, the references in the literature to its primary structure, that is, the structure previous to the commencement of secondary thickening, are extremely few. Binney, who was struck with the fact that the size of the specimens met with varies within wide limits, refers<sup>1</sup> to small stems which were not more than  $\frac{3}{50}$  of an inch in diameter, but even in these secondary thickening had begun, for his description shows that a zone of secondary xylem, at least two elements in thickness, had already been developed. Solms-Laubach remarks that "almost all the petrified specimens which have been examined show the presence of secondary wood," and gives no description of the stage where such wood is absent; while Schenk<sup>2</sup> candidly confesses that in all the sections seen by him the formation of secondary wood had already begun. It is only in Williamson's fine series of *Memoirs* that any account of the early condition of a Calamitean stem is to be found, and this is given in the ninth *Memoir*, which was published in 1878.

In that *Memoir*<sup>4</sup> Williamson describes several stems which were still in an early stage of development, but in

---

<sup>1</sup> Observations on The Structure of Fossil Plants, Part I., p. 16. *Palaeontographical Society*, 1868.

<sup>2</sup> *Fossil Botany*, p. 295.

<sup>3</sup> *Die fossilen Pflanzenreste*, p. 107.

<sup>4</sup> *Philosophical Transactions*, 1878, p. 322.

all of which the pith, carinal canals, and cortex were distinguishable. One of them was "not more than 0.033 inch in diameter," and the stage it had reached may be inferred from the following description which Williamson gives of it:—

"The medullary cells are here unruptured, the medullary fistular cavity having as yet no existence. Nine longitudinal internodal canals are seen, and these form the only recognisable line of demarcation between the pith and the bark [cortex]. There is little difference between the cells of these two structures."<sup>1</sup>

Another, which was slightly more advanced, he describes thus:—

"We still discover the bark [cortex], the internodal canals, again nine in number, and the medullary parenchyma; but the bark [cortex] in this example is a thick layer of parenchyma of coarser tissue than that composing the medulla, and the latter now displays a central fissure, which obviously indicates the commencement of the medullary fistular cavity. We have but still very slight indications of the formation of woody wedges external to each of the internodal canals."<sup>2</sup>

From these descriptions and the figures which accompany them, these two stems seem to have been so young that even the primary structure had not received its full development. Summarising the facts obtained from a study of the whole of the specimens Williamson describes this early condition and some of the subsequent changes in the following terms:—

"One thing is clear, viz., that the bark [cortex] as we see it in Figs. 8, 10 and 13, is a primitive generalised parenchyma; but as the stems become arborescent this generalised tissue developed within its interior the thick layer of prosenchyma, which resembles so closely the cork layer of living phanerogams."<sup>3</sup>

---

<sup>1</sup> *Loc. cit.*, p. 322.

<sup>2</sup> *Ibid.*, p. 322.

<sup>3</sup> *Ibid.*, p. 324. The figures referred to are on Plates 19 and 20 of the *Memoir*.

Since the publication of this account of the primary condition of the stem of *Calamites*, I cannot discover that anything has been added to it, a result which is doubtless due to the fact that stems of a suitable age and in a proper state of preservation are so rarely met with. In now attempting to carry our knowledge somewhat in advance of this, I shall base my statements upon an exquisite series of sections prepared some time ago by Mr. James Binns, of Halifax.

One of the specimens is a transverse section of a young stem, which is represented on Plate IX., Fig. 1. It is roughly elliptical in shape, but broader at one end than the other. The length of the major axis is  $\frac{1}{16}$  inch, and the breadth of the broader end, at the margin of the pith cavity, is  $\frac{1}{20}$  inch. Except the central part of the pith, which has disappeared, all the tissues are preserved, and that in a degree of perfection and clearness which is rarely met with in the petrifications of Carboniferous plants. The peripheral part of the pith forms a zone of parenchyma, *a*, on the inside of the primary vascular bundles, which has a breadth of  $\frac{1}{300}$  inch. If complete, the pith would form a nearly elliptical mass of tissue, the longer diameter of which would be  $\frac{11}{300}$  inch and the shorter  $\frac{8}{300}$  inch. The periphery of the section shows a number of irregular projections, which indicate that the stem was not smooth but marked by longitudinal ridges and bands. Some of them were merely narrow wing-like extensions, *b*, but others, *c*, were broader. The latter were not rounded, however, but flattened, and had more or less angular edges. How far accident has entered into the formation of these ridges it is impossible to say, but the normal appearance of the tissue beneath them proves that, to a large extent, if not wholly, they are natural.

Surrounding the zone of pith are the primary vascular bundles, *d*, Fig. 1, which are here 16 in number. Like those of *Equisetum*, they are imperfect, the xylem consisting of

little more than the carinal canal, formed by the breaking down of the initial strand of vessels. A striking and remarkable feature of some of these canals is the presence, at the margin, of projecting elements, which I have no hesitation in interpreting as the remnants of the vessels, *v*. The presence of these elements gives the canals an appearance which is perfectly identical with that of the homologous canals of *Equisetum*, but the lateral xylem elements found in the latter plant are not distinguishable.

External to each canal is a mass of small elements, *p*, which, from their position and their distinct character when compared with the ground tissue on either hand and between the canals, must be regarded as the phloem of the primary bundles. It is true that some of the histological characters of phloem cannot be recognised in these groups of elements, but this is most probably due to the fact that in the process of fossilisation, their contents have all disappeared. If, however, they be compared with the phloem of *Equisetum* after the protoplasm, &c., has been removed, it will be found that they are in close agreement therewith not only in position, but in the size and general arrangement of the constituent elements. If a pericycle ever existed outside this phloem, it is no longer recognisable.

Still moving outward, we next come to a sharply defined line, *s*, which is traceable nearly all round the stem, just outside the ring of primary vascular bundles. The line is slightly undulated, the parts opposite the bundles being convex, and those opposite the medullary rays concave, outwardly. I regard it as marking the boundary between the stele, or vascular-bundle cylinder, and the cortex. In most of my preparations, it is apparently a simple but thick black "line," but in the one under description, and one or two others, there are vague indications of a single layer of narrow cells in place of the "line" at some points. If this could be proved to be the normal structure, few would

hesitate to call the layer of narrow cells the endodermis, and to regard the axis as monostelic. But at present this has not been done. Nevertheless there are good reasons for regarding this "line" as the boundary between the stele and the cortex. In the first place, it is strongly suggested by the typical species of *Equisetum*, e.g., *E. arvense* and *E. maximum*, which, it will be allowed, are something more than analogous. In the second it is supported by the mode of origin and the development of the secondary xylem, as will be shown later.

Outside the "line" just dealt with, we have the cortical tissues, which are here seen to present a considerable amount of differentiation. At the first glance, indeed, it is obvious that the cortex of this specimen has a remarkably complex structure. It is made up of two layers or zones, an outer and an inner, *o*, *i*, between which runs a dividing line, which is undulated and roughly parallel to the surface of the stem.

The inner zone is the broader of the two—having a breadth of  $\frac{1}{150}$  inch—and is generally much better preserved. In the middle of it the elements, though of different sizes, are for the most part large and angular, and in shape and arrangement are not unlike the xylem elements of the vascular bundle of a fern. But the walls are not specially thickened, and the cavities frequently contain black carbonaceous masses, *m*. Whether these represent special substances, such as resin, tannin, or latex, or merely an unusual accumulation of ordinary cell contents, it is impossible to say. Between the black masses, which are usually eccentric, and the distant cell wall, a faint concentric line is often discernible, recalling the appearance of the primordial utricle of recent plants. This, and the whole appearance of the zone, seem to show that the contents of these elements were introduced in the living state, and are not mere infiltrations into empty cavities during the fossil-



ising process. On the inner, and more especially on the outer, side of these larger and more central elements, which are practically continuous all round the stem, are smaller elements of a different character, *n*. In transverse section, they have a more circular outline, and there are distinct evidences of thickening deposits having been laid down upon the original walls. On the outer side of the zone under description they form two or three layers, and at some points they are found penetrating in triangular masses between the larger elements of the middle. On the inner side they chiefly fill up the angles between the larger middle elements, so that the entire zone has a tolerably uniform width, with more or less even and uniform margins.

The outer zone of the cortex, *o*, is seldom well preserved, but it appears to have been composed of a thin-walled tissue, in which thicker-walled elements were imbedded. The latter have very thick walls, with clear rounded lumina, and are somewhat irregularly distributed. A curious point is, that they vary much in size.

At the periphery of the section is the epidermis, but in this, as in most specimens, its structure is for the most part obliterated. At a few isolated points, however, we can make out that it originally consisted of a single layer of cells.

My efforts to obtain longitudinal sections of this type of stem in its primary condition have not yet been as successful as could be desired. Numerous fragments have been met with, but no one large and complete enough to give a connected view of the primary tissues in their longitudinal aspect. Nevertheless, by putting together the items of information picked up from a large number of these fragments, we may obtain a fairly reliable idea of the longitudinal structure, at least in its main outlines. The following description is based upon knowledge obtained in this way.

The pith, so far as it is preserved, is made up of thin-walled cells, elongated longitudinally, which are usually narrower at the periphery than towards the centre. In some cases a few larger cells, with carbonaceous contents, are intermingled with the smaller peripheral ones, but these are not present in the transverse sections figured. They have a close resemblance to the cells which occupy the middle of the inner zone of the cortex. The pith cells at the nodes are rounded, and may or may not contain accumulations of carbonaceous matter.

The vascular elements which cling to the sides of the carinal canals are not all of one kind. Some of them are clearly annular, and others are spiral; but occasionally reticulated ones are also present, a state of things which may occur in *Equisetum*.

Longitudinal views of the phloem are much rarer and still more fragmentary than those through the xylem, and at present I can only say that the phloem elements appear to be narrow elongated structures.

Coming to the cortex, it may be said with some degree of confidence that the larger elements of the inner zone, though often considerably elongated, are nevertheless cellular. They are, in fact, several times as long as broad, they have oblique or square ends, and stand in vertical rows. But there are no signs of thickening or sculpturing of the walls. The carbonaceous contents are usually retracted from the side walls, and at the ends sometimes take the expanded, trumpet-like form, characteristic of the contents of some sieve-tubes. This, and the arrangement in vertical rows, suggests that they formed conducting channels, but the nature of the conducted materials cannot at present be determined.

With respect to the outer zone of the cortex, little has been made out in the longitudinal view beyond the fact that the thick-walled elements seem to be more or less fibrous

in form, and probably belong to the category of sclerenchymatous fibres.

From this account of the primary structure of this type of Calamitean stem, it will be seen that the specimens now described differ in many respects from those described and figured by Williamson in 1878. As already stated, the tissues are much more differentiated, and that in nearly every part of the stem. In the pith, we have the elements at the periphery smaller than those in the centre, and the occasional occurrence of larger elements with black contents, may be indicative of other differences. In the stele, we have phloem strands accompanying the carinal canals, to the walls of which the torn vessels still adhere, and there is a sharp distinction between the stele and the cortical tissues. The latter again are distinguishable into two zones, and within each there are considerable histological differences, which add to the complexity of the whole, and make it a very different structure from the "primitive generalised parenchyma" of Williamson's specimens. My own impression is, that these differences are due to the fact that the latter appear to be in an earlier stage of development than those under treatment, which seem to present the primary structure fully matured and ready for the initiation of secondary thickening. It is possible, however, that the two sets of specimens do not belong to the same type of *Calamites*, and that this is the explanation of the want of agreement between them.

An interesting question in connection with the fossil plants of the Coal Measures is the degree of correspondence between the size of a stem and the extent of the development it has undergone. The preparations under consideration appear to throw a little light upon it. The transverse section of the stem which has been described in detail, measures, as already stated,  $\frac{1}{16}$  inch by  $\frac{1}{20}$  inch. But my collection includes others smaller than this, in which

practically the same structure obtains, and that in equal perfection. Of these one measures  $\frac{2}{75}$  inch by  $\frac{1}{50}$  inch, and another, which is circular, has a diameter which is not more than the latter figure. Thus in stems which range in diameter from  $\frac{1}{50}$  to  $\frac{1}{18}$  inch, we have the same differentiation into stele and cortex, and within these an equal complexity of structure.

Another subsidiary point of some interest receives fresh elucidation from these specimens, viz., the nature of the lacunae, which are almost constantly present in the primary vascular bundles of *Calamites*. Most palæobotanists now accept the interpretation of Solms-Laubach that "in the lacunae, or the tissue that fills them, we are dealing with the tracheal initial strand of the primary bundle."<sup>1</sup> This interpretation, however, has hitherto been based entirely upon transverse sections, the author quoted pointing out, that longitudinal sections bearing upon the point are precarious, and "are of value only when the sculpture of the walls is preserved, which is seldom the case." No such sections appear to have been described hitherto, and hence it seems worth while to note that the sections here dealt with are exactly of the kind required, and fully confirm the interpretation of the lacunae suggested by Solms-Laubach.

These matters disposed of, we may now turn to one of much greater importance, viz., the place of origin of the secondary thickening and the first changes brought about by the same.

Fig. 2 represents a stem of the same type of *Calamites* as those previously described, but it is much older, and has developed a zone of secondary xylem which is nearly  $\frac{1}{50}$  inch in breadth. It was partially described by Mr. W. Cash and myself many years ago<sup>2</sup> and has its tissues much more

---

<sup>1</sup> Fossil Botany, p. 298.

<sup>2</sup> *Proceedings of the Yorkshire Geological and Polytechnic Society*, 1883.

complete and in a much finer state of preservation than any other section I have yet come across. In it will be seen the pith,  $\alpha$ , surrounded by the carinal canals,  $d$ , seventeen in number, arranged as in the younger specimens. But outside each carinal canal is a wedge-shaped mass of secondary xylem,  $x$ , and between these masses are the somewhat broad medullary rays,  $r$ . It will be noticed that, as has been pointed out by several observers,<sup>1</sup> the first formed elements of the secondary xylem stand near or abut upon the carinal canals, and the rest are developed centrifugally in radiating rows. Hence, as the young stems described in this paper show phloem strands in immediate proximity to the canals,<sup>2</sup> it seems a warrantable inference that the secondary thickening begins in the position usual for open collateral bundles, *i.e.*, between the phloem and the xylem.

As the development of the secondary xylem would necessitate the displacement of the phloem and the 'line' of demarcation between the stele and the cortex, one naturally looks for traces of these in the older stems; but so far I have not been able to detect them. It is otherwise, however, with the cortical tissues. At  $i$  we have the inner cortical zone of the older stem, and it needs little examination to see that it is identical with that of the primary stem. (Fig. 1,  $i$ .) The arrangement and general appearance of the elements are the same in both cases, and the same may be said of their histological structure. The breadth in the older stem, as in the younger, is  $\frac{1}{150}$  inch, so that there has been no growth in the radial direction. Obviously, however, there must have been growth in the tangential direction, as the layer still completely encircles the stem, though not quite so uninterruptedly as in the earlier stage.

---

<sup>1</sup> See especially Binney *loc. cit.*, and Williamson, *Philosophical Trans.*, 1871.

<sup>2</sup> *Ante*, p.

In the outer cortical zone, we again recognise the thin-walled tissue at *o*, but its bulk is still small. In it are a few lacunae, *l*, but whether they are natural air-canals, or due to accidental rupture, there is nothing to show. The thick-walled elements, on the other hand, have increased considerably, and now form a dense thick hypodermal layer, *s*, which appears to have been sclerenchymatous. The elements of this layer are not arranged in radiating series, nor are they grouped in triangular bundles, thus differing from the corresponding tissues described by Williamson.<sup>1</sup>

On the whole then, it would seem that the structure of the cortex, as seen in the primary stem of this type of *Calamites*, retains its characteristic features for some time after secondary thickening has set in, the chief modification, apart from the doubtful lacunae, being the increase in the mechanical tissue.

Reviewing the facts as set forth in what has gone before, botanists will probably be most struck with the remarkable features of the tissue which makes up the inner zone of the cortex. From what I have seen of it, in many preparations, I am convinced that it is an important tissue both in a morphological and a physiological sense, though I cannot as yet specify in what its importance consists. It is not confined entirely to the stem, but is found also in the leaves, where it forms a conspicuous layer, which extends from one edge to the other, and runs from base to apex beneath the epidermis on the convex side. Finally, an identical layer is present in a similar position in the sterile bracts of *Calamostachys Binneyana*, as I have shown elsewhere,<sup>2</sup> awakening the suspicion that in the type of *Calamites* here considered we have the plant that bore *Calamostachys Binneyana* as its fruit-spike.

---

<sup>1</sup> *Phil. Trans.*, 1878, p. 324; *Ibid.*, 1881, p. 465.

<sup>2</sup> *Proceedings of the Yorkshire Geological and Polytechnic Society*, 1893, p. 287.

Not the least perplexing fact about this tissue is that it appears to belong to the cortex, as has been pointed out in the earlier portion of this communication. In some respects it is not unlike a well-developed phloem tissue, and when the older stem was first described by Mr. Cash and myself in 1884, we called attention to this, and tentatively suggested that it might be the phloem of the secondary bundles. Now however that we know it to be a constituent of the cortex of the primary stem, and find it as a broad longitudinal band in the leaves, it is clear that this view of its nature can no longer be put forward. In 1876 M. Renault described<sup>1</sup> a form of *Calamites*, which he named *Arthropitys lineata*, in which he found a layer of cortical tissue in which were elements that somewhat resembled those of the layer before us, so far as one can judge in the absence of figures. He speaks of it as a cellular layer, enclosing groups of resin canals, placed in front of the secondary xylem bundles. Solms-Laubach questions this interpretation,<sup>2</sup> but whether true or not for Renault's specimens, it is scarcely applicable to the case before us. For here we have a zone of tissue which is practically uniform and continuous round the whole stem, and not merely a number of isolated "groups" of elements, distinct from, but imbedded in, an ordinary cellular layer. Moreover, the elements of this tissue are themselves mainly cellular, and the carbonaceous masses they contain are apparently derived from the normal cell contents. They might be secretory reservoirs of some kind, but their arrangement as a special tissue is not in favour of this view, and their longitudinal course, both in the stem and the leaves, is more suggestive of the function of conduction, as already stated.

Turning to *Equisetum*, as the living representative of

---

<sup>1</sup> *Comptes rendus*, Vol. 83 (1876) p. 574.

<sup>2</sup> *Fossil Botany*, p. 301.

*Calamites*, we find little in its structure to elucidate the nature of the tissue under consideration. Strasburger mentions<sup>1</sup> that in *Equisetum maximum* tannin bearing elements are scattered in the ground tissue, both of the stele and the cortex, and that they are elongated structures arranged in longitudinal series. These, however, are scarcely comparable with the elements of the inner cortical zone of *Calamites*, though they are not unlike the groups of cells with black contents, sometimes seen in the pith.

For the present, then, we may leave the interpretation of this peculiar tissue an open question, in the hope that further specimens may soon be forthcoming to throw additional light upon it.

---

#### EXPLANATION OF THE FIGURES.

- Fig. 1.* Transverse section of the Stem of a young *Calamites*.
- a.* Peripheral portion of the pith.
  - b, c.* Narrow and broad ridges respectively at the surface of the stem.
  - d.* Carinal canals of primary vascular bundles.
  - v.* Carinal canals with projecting vascular elements.
  - p.* Phloem of primary vascular bundles.
  - s.* Boundary between the stele and the cortex.
  - i, o.* Inner and outer zones respectively of the cortex.
  - m.* Elements of inner cortical zone with black contents.
  - n.* Smaller elements of inner cortical zone.
- Fig. 2.* Transverse section of Stem of *Calamites* with secondary thickening.
- a.* Pith.
  - d* Carinal canals of primary vascular bundles.
  - x.* Secondary xylem.
  - r.* Medullary rays.
  - i, o.* Inner and outer cortical zones respectively.
  - l.* Lacunae in the outer cortical zone.
  - s.* Sclerenchyma of do. do.

---

<sup>1</sup> *Histologische Beiträge*, Heft III., p. 433.



Fig. 1.

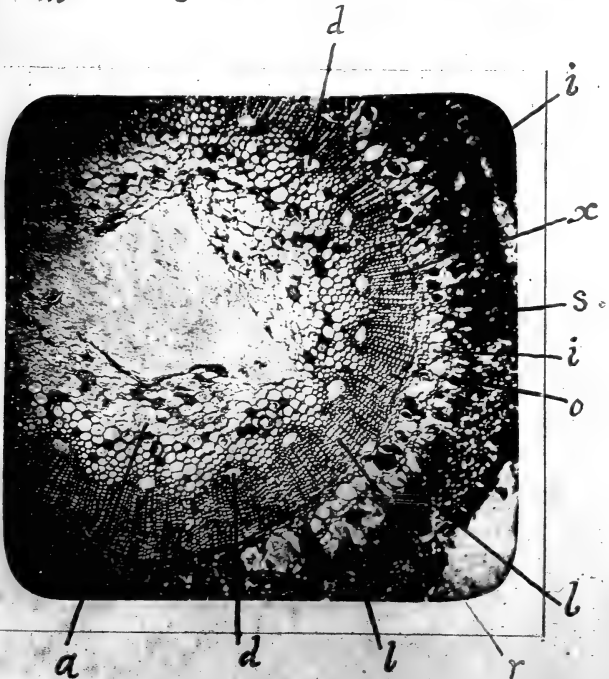
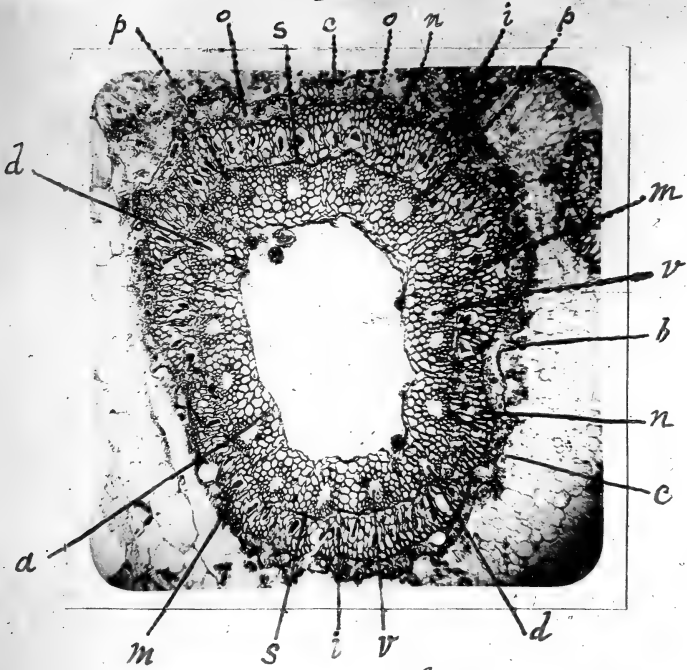

Fig. 2.



Annual General Meeting, April 17th, 1894.

Professor ARTHUR SCHUSTER, PH.D., F.R.S., F.R.A.S.,  
President, in the Chair.

The following gentlemen were elected Honorary Members :—

Prof. PAUL APPELL, Paris ; J. W. L. GLAISHER, D.Sc., F.R.S., Cambridge ; Prof. L. KÖNIGSBERGER, Leipsic ; Prof. M. SOPHUS LIE, Copenhagen ; Prof. A. GOUY, Paris ; Prof. E. WARBURG, Freiburg ; Dr. G. NEUMEYER, Director of the See Warte, Hamburg ; Prof. E. J. STONE, F.R.S., Radcliffe Observer, Oxford ; Prof. H. A. ROWLAND, For. Mem. R.S., Baltimore ; OLIVER HEAVISIDE, F.R.S., Paignton, Devon ; Prof. W. OSTWALD, Leipsic ; A. G. VERNON HARCOURT, F.R.S., Oxford ; Dr. H. DEBUS, F.R.S., Cassel ; Prof. T. E. THORPE, F.R.S., London ; Prof. PFEFFER, Jena ; Dr. JOHN MURRAY, Edinburgh ; Prof. Sir WM. TURNER, F.R.S., Edinburgh ; Prof. A. WEISMANN, Freiburg ; Prof. SIDNEY VINES, F.R.S., Oxford ; Prof. H. M. WARD, F.R.S., Cooper's Hill ; Prof. C. M. GULDBERG, Christiania ; Pro. P. WAAGE, Christiania ; Prof. J. S. BURDON SANDERSON, F.R.S., Oxford.

The Annual Report of the Council was presented and amended, and it was moved by Mr. J. B. MILLAR, M.E., seconded by Mr. S. C. TRAPP, and resolved :—" That the Annual Report as amended be adopted, and printed in the Society's *Memoirs and Proceedings*."

It was moved by Mr. W. E. HOYLE, M.A., seconded by Mr. S. C. TRAPP, and resolved :—" That the system of electing Associates of the Sections be continued during the ensuing session."

The following gentlemen were elected Officers of the Society and members of the Council for the ensuing year :—

*President*.—HENRY WILDE, F.R.S.

*Vice-Presidents*.—EDWARD SCHUNCK, Ph.D., F.R.S.,

F.C.S.; OSBORNE REYNOLDS, M.A., LL.D., F.R.S., &c.; ARTHUR SCHUSTER, Ph.D., F.R.S., F.R.A.S.; JAMES COSMO MELVILL, M.A., F.L.S.

*Secretaries.*—FREDERICK JAMES FARADAY, F.L.S., F.S.S.; REGINALD F. GWYTHER, M.A.

*Treasurer.*—CHARLES BAILEY, F.L.S.

*Librarian.*—FRANCIS NICHOLSON, F.Z.S.

*Other Members of the Council.*—HAROLD B. DIXON, M.A., F.R.S.; ALEXANDER HODGKINSON, M.B., B.Sc.; JAMES BOTTOMLEY, B.A., D.Sc., F.C.S.; Alderman JOSEPH THOMPSON; FRANCIS JONES, F.R.S. Ed., F.C.S.; W. E. HOYLE, M.A.

---

Ordinary Meeting, April 17th, 1894.

Professor ARTHUR SCHUSTER, Ph.D., F.R.S., F.R.A.S.,  
President, in the Chair.

The thanks of the members were voted to the donors of the books upon the table.

Professor DIXON, M.A., F.R.S., read a paper "On the Instantaneous Pressures produced in the Explosion-Wave."

---

*[Microscopical and Natural History Section.]*

Annual Meeting, 9th April, 1894.

Mr. R. E. CUNLIFFE, President of the Section, in the Chair.

Mr. BROADBENT described some observations on fission in the Infusoria.

Mr. OLDHAM exhibited some bird snares used by the inhabitants of the island of St. Kilda for capturing the Fulmar Petrels and the Puffins. Also the oil vomited by the Fulmar when captured, and the receptacle made from the crop or stomach of the guillemot, in which the islanders collect the oil. This oil was formerly used as a specific for rheumatism and for dipping sheep.

Mr. ALLEN showed a specimen of alloy made from 60 per cent of copper and 40 per cent of manganese, and described a number of observations on the injurious effects of noxious vapours brought by prevalent winds from manufacturing towns.

The Annual Report of the Council, and the Treasurer's Financial Statement, were presented and adopted.

The following gentlemen were elected Officers and Council for the ensuing Session :—

*President.*—JOHN BOYD.

*Vice-Presidents.*—PETER CAMERON, F.E.S. ; ROBERT ELLIS CUNLIFFE ; JAMES COSMO MELVILL, M.A., F.L.S.

*Treasurer.*—MARK STIRRUP, F.G.S.

*Secretary.*—THEODORE SINGTON.

*Council.*—CHARLES BAILEY, F.L.S. ; GEORGE HARRY BROADBENT, M.R.C.S. ; HERBERT C. CHADWICK, F.R.M.S. ; ROBERT DUKINFIELD DARBISHIRE, B.A., F.G.S., F.S.A. ; ALEXANDER HODGKINSON, M.B., B.Sc. ; HENRY HYDE ; FRANCIS NICHOLSON, F.Z.S. ; THOMAS ROGERS.

**On the instantaneous pressures produced in the Explosion-Wave.** By H. B. Dixon, F.R.S., Professor of Chemistry, and J. C. Cain, B.Sc., 1851 Exhibition Scholar in the Owens College.

*(Received May 22nd, 1894).*

The problem of directly measuring the pressure produced in the 'explosion-wave' of a mixture of gases is one of great difficulty. The movement of the wave is so rapid, and the zone of high temperature so thin, that the high pressure over any given area lasts an exceedingly short time. Nevertheless the problem is one of great importance for the elucidation of the phenomena of explosion.

To take one instance: If the pressure produced in the explosion-wave could be accurately measured it would decide between the two theories of gaseous explosions that have been put forward. According to M. Berthelot\* the velocity of explosion is equal to the mean rate of translation of the products of combustion heated at constant pressure. In the alternative hypothesis† the velocity of explosion is equal to the velocity of sound in the burnt and burning gas at a temperature *double* that due to the combustion of the gases at constant volume. The calculated temperatures and pressures of the explosion-wave are very different in the two hypotheses. For example, in the explosion of cyanogen with its own volume of oxygen the pressure in the wave is calculated to be 35 atmospheres according to the first view; it is calculated to be 117 atmospheres according to the other. In the elaborate investigation made by M. Berthelot, in conjunction with M. Vieille, on the pressures produced in the explosion of gases, the

---

\**Sur la force des matières explosives.*

† H. B. Dixon, *Phil. Trans.*, vol. 184., p. 134 (1893).

pressure produced in this reaction is given as 25 atmospheres, a number more in accordance with the first than the second hypothesis.

But the measurements made by MM. Berthelot and Vieille\* do not, we think, apply to the pressures in the *wave*. They fired mixtures of gases in a bomb and observed the movement of a piston working against a spring in a tube attached to the bomb. From the *acceleration* of the piston they calculated the pressure in the bomb. The pressures so measured are called by Berthelot the "effective pressures." Now, since the explosion-wave travels faster than sound in the unburnt gas, the explosion-wave is the first impulse which reaches the piston. It follows that when the piston feels this impulse and begins to answer to it, the explosion-wave has traversed the whole of the gas and the true explosion is over. The piston receives the blow of the wave and then the thrust of the expanding gases, no doubt still combining, to a greater or less extent, *behind* the wave front. In Berthelot's experiment, therefore, the movement of the piston gives, in the main, the rate of expansion of the heated gases after the explosion-wave has passed through them: it does not give the instantaneous pressure in the wave front itself. That higher pressures are produced for a moment in the explosion of gases has been proved by Mallard and Le Chatelier by the use of the delicate indicator designed by Deprez. MM. Mallard and Le Chatelier have also suggested a method of measuring these pressures by the fracture of glass tubes of known strength. This method we believe to give approximately correct results: it depends on the principle that if a pressure is produced in a glass tube greater than it can stand, the glass will be broken although the pressure may only last for a very small interval of time.

---

\* Ann. Chim. et Phys. [vi.] 4, p. 14 (1885).

In 1893 one of us published some preliminary experiments by this method.\* Tubes which stood a steady hydraulic pressure of 25 atmospheres, were broken into small fragments by the explosion-wave of carbonic oxide and oxygen; whereas, stronger tubes which stood a pressure of 50 atmospheres were not broken by the explosion of oxygen, either with carbonic oxide or with hydrogen; on the other hand, the stronger tubes which had withstood 50 atmospheres on the hydraulic press, were broken by the explosion of cyanogen and oxygen in equal volumes, and one of these tubes was broken at 78 atmospheres on the press. It seemed desirable to repeat these experiments and to find, if possible, narrow limits within which the pressure of the explosion-wave must lie.

Cyanogen was chosen as the combustible gas for most of the experiments, because the carbonic oxide and nitrogen yielded by its explosion with oxygen are simple in composition and approximate in physical properties to a perfect gas. Equal volumes of cyanogen and oxygen were mixed in an iron gas-holder over mercury. The explosion vessel consisted of a firing-piece with platinum wires, and two metal tubes between which the glass tube to be tested could be inserted by means of Faraday's cement. After the apparatus had been filled with gas from the holder, the taps were closed at each end, and a spark was passed. The explosion-wave was generated in the first metal tube and traversed the glass tube. If the latter held it was removed and labelled; and another tube inserted in its place. The glass tubes were about 20 cm. in length; they were cut from long tubes of fairly uniform bore and thickness of wall. When a tube was broken it was our endeavour to gauge its strength by testing hydraulically the strength of the pieces cut on either side of it from the parent tube.

---

\* H. B. Dixon, *Phil. Trans.*, Vol. 184, p. 150.



With equal volumes of cyanogen and oxygen, a very high pressure is produced in the explosion-wave. Soda-lime glass tubing of 18 mm. external diameter, and 2.5 mm. thickness, was fractured by the explosion. Green glass tubing of 2.8 mm. in thickness held. Experiments with the hydraulic press showed a very considerable difference in the strength of these tubes. Three pieces of the first glass broke when submitted to the following pressures :—

1. 890 lbs. on the square inch.
2. 950 „ „
3. 1220 „ „

—  
mean 1020 „ „ = 70 atmospheres.

We think it safer to take the mean breaking strain of the three pieces as representing the strength of the tubes broken by the explosion, than to take the highest figure as the minimum force exerted by the explosion. We thus come to the conclusion that the pressure exerted in the explosion-wave exceeded 70 atmospheres. Pieces of the green glass tubing which withstood the explosion gave very unequal results on the press :—

1. 2050 lbs. on square inch.
2. 1450 „ „

—  
mean 1750 „ „ = 120 atmospheres.

Unfortunately we had no other specimens of the same kind to test. Our result, therefore, is that in the explosion of equal volumes of cyanogen and oxygen, the pressure produced falls between the limits of 60 to 140 atmospheres, and more probably between 70 and 120 atmospheres.

In the next experiments, the mixture of equal volumes of cyanogen and oxygen was diluted with its own volume of nitrogen. The reaction occurring may be written :—



The “effective pressure” produced on firing this mixture

in a bomb has been measured by Berthelot, and found to be 15 atmospheres. As calculated from Berthelot's theory, the pressure in the wave should be 18 atmospheres; according to Dixon 57 atmospheres. One reason which led us to dilute the explosive mixture was suggested to us by Professor Osborne Reynolds. If the velocity of the explosion-wave in the gas approximates to the rate at which the distortion-wave in the glass is propagated, the latter might be continually re-inforced, and the tube be broken as the result of a pressure far less than that required to break it under other conditions. The velocity of this wave in glass is nearly 3,000 metres per second. The rate of explosion of equal volumes of cyanogen and oxygen is 2,728 metres per second; when this mixture is diluted with its own volume of nitrogen, the rate of explosion falls to 2,163 metres per second. In the diluted mixture, therefore, there could be no question of the waves coinciding in rate.

The reduction of pressure caused by dilution made the measurement more accurate, as it enabled us to find glass of more nearly equal strength holding and breaking respectively. After several trials a piece of uniform tube was found which broke, and a slightly thicker one which held. Two pieces of the first broke at the following pressures:—

|    |                          |                   |  |
|----|--------------------------|-------------------|--|
| 1. | 950 lbs. on square inch. |                   |  |
| 2. | 925 „ „ „                |                   |  |
|    | —                        |                   |  |
|    | mean 938 „ „ „           | = 63 atmospheres. |  |

Two pieces of the second broke:—

|    |                           |                   |  |
|----|---------------------------|-------------------|--|
| 1. | 1230 lbs. on square inch. |                   |  |
| 2. | 1250 „ „ „                |                   |  |
|    | —                         |                   |  |
|    | mean 1240 „ „ „           | = 84 atmospheres. |  |

The lower limit viz., 63 atmospheres, is rather higher than the pressure calculated by Dixon's formula.

An indirect way of arriving at the pressures in the explosion-wave is given by Riemann's\* equation for the propagation of abrupt variations in the density and pressure of a gas. Professor Schuster † has given reasons for supposing that Riemann's equation applies for the explosion-wave, and has shown a simple way of calculating the pressures from the known velocity of the explosion-wave and the density of the unburnt gas. According to Riemann's equation the pressure in the explosion-wave of cyanogen and oxygen should be 135 atmospheres, and when diluted with its own volume of nitrogen the pressure should be 71 atmospheres. The calculated and observed pressures may be conveniently compared in the annexed table :—

*Pressures in the Explosion-wave.*

| Gaseous Mixture.      | CALCULATED. |         |          | OBSERVED.  |               |
|-----------------------|-------------|---------|----------|------------|---------------|
|                       | Berthelot.  | Dixon.  | Riemann. | Berthelot. | Dixon & Cain. |
| $C_2N_2 + O_2$        | 35 At.      | 117 At. | 135 At.  | 125 At.    | 70—120        |
| $C_2N_2 + O_2 + 2N_2$ | 18 „        | 57 „    | 71 „     | 15 „       | 63—84         |

It will be observed that the pressures calculated by Riemann's equation are about 4 times greater than those deduced from Berthelot's Theory : and are larger (roughly by 20 per cent) than those calculated from Dixon's They agree within the limits of error with our observations on the breaking strain of glass tubes.

*Experiments on the Collision of Two Explosion-waves.*

The apparatus we employed could readily be adapted to observe the effect of bringing two explosion-waves into collision. Will the result of two waves meeting from

\* 'Göttingen Abhandlungen.' 8. (1860).

† *Vide Phil. Trans.* Vol. 184, p. 152. (1893).

opposite directions be to largely increase the pressure at the point of contact? By analogy one might suppose that such would be the case; but, on the other hand, since the explosion travels much faster than any wave in the unburnt gas the explosion-wave is always, as it were, dashing on a dead wall and piling up pressure, and no further effect, it might be argued, could be produced when it meets and is repulsed by a similar wave. It seemed, however, possible if the wave is propagated partly by the movement of heated yet unburnt molecules in the wave front—that *these* molecules on coming into collision would cause a measurable increase of temperature and pressure in the wave. We have not been able to measure any such increase by this rough method of trial. The explosion tube, some 3 feet from the firing point, bifurcated into two arms like the letter Y. The two arms were bent round nearly to meet, and the junction was effected by a piece of glass tube inserted in the gap. The centre of the glass tube was exactly equi-distant from the fork by either arm; consequently the explosion-wave, dividing into two at the fork, traversed the two arms and came into collision in the middle of the glass tube. By a suitable tap, one arm could be closed, and the explosion then traversed the glass tube only in one direction. Experiments made with hydrogen and oxygen, with equal volumes of cyanogen and oxygen, and with the same mixture diluted with nitrogen as before, showed no appreciable difference between the pressures produced in the glass tube when the flame went in one direction only and when the two explosion-waves met end on. Pieces of the tube, which broke in the hydraulic press at 63 atmospheres, broke both ways equally in the explosion apparatus: pieces of the tube, which broke in the hydraulic press at 84 atmospheres, stood the explosion both ways equally. If the collision had caused the pressure to rise by  $\frac{1}{3}$  we ought to have detected it.

**On the Influence of the Configuration and Direction of Coast Lines upon the Rate and Range of the Secular Magnetic Declination. By Henry Wilde, F.R.S.**

*(Received April 3rd, 1894.)*

In a paper which was read before the Royal Society in June, 1890, I showed that the principal phenomena of terrestrial magnetism and the secular changes in its horizontal and vertical components could be explained on the assumption of an electro-dynamic substance (presumably liquid or gaseous) rotating within the crust of the earth in the plane of the ecliptic, that was to say, at an angle of  $23^{\circ}5'$ , and a little slower than the diurnal rotation. By means of some electro-mechanism, new to experimental science, which I termed a Magnetarium, the period of backward rotation of the electro-dynamic sphere required for the secular variations of the magnetic elements on different parts of the earth's surface was found to be 960 years, or  $22^{\circ}5'$  minutes =  $0^{\circ}375'$  annually.

From the relations of a magnetic needle on the earth's surface, and an electric current circulating round the internal electro-dynamic sphere, it will be obvious that the magnetism of such a system would be symmetrically distributed, with similar lines of declination and inclination on meridians and parallels  $180^{\circ}$  from each other. An examination, however, of the lines of declination over the terrestrial globe, as determined by careful and repeated observations, exhibits wide divergencies from the symmetrical lines of declination obtained with the electro-dynamic sphere alone.

Thus, there are on the variation chart (Plate X.) four

well-defined lines of no declination in the northern hemisphere, for two similar lines of no declination in the southern hemisphere. The declination also varies very considerably for equal latitudes and longitudes in the northern and southern hemispheres, for the same or for different epochs. This is seen in the large amount of the declination at the Cape of Good Hope, and the small amount on the great land areas of Eastern Europe and Asia, as well as over the Eastern States of North America. The comparatively small area, or oval, of westerly declination in Eastern Asia, surrounded by considerable areas of easterly variation, together with the closed curve of small easterly variation in the equatorial parts of the Pacific, contributes still further to increase the difficulty of the problem of reducing the distribution of the earth's magnetism to general laws. The unsymmetrical character of the lines of equal variation, and the devious courses of the lines of equal inclination and the magnetic equator, are no less perplexing to magneticians than the irregularities of the declination at different epochs for equal latitudes.

In the course of my experiments, it was noticed that the lines of no declination of the internal sphere of the magnetarium were generally in advance of those on the charts for a given epoch. Thus the two antarctic lines of no declination were more than  $40^{\circ}$  east of the similar lines of the electro-dynamic sphere for the epoch 1880.

With the object of ascertaining what influence the configuration of the surfaces of the terrestrial globe, as indicated by the general distribution of land and water, had on the magnetic elements, the ocean areas of the outer globe of the magnetarium were covered with thin sheet iron roughly contoured to the coast lines in both hemispheres. On turning the internal electro-dynamic sphere  $84^{\circ}$  W. to correspond with the epoch 1880, a remarkable change in the magnetic elements was manifested. The two

lines of no declination in the southern hemisphere of the outer globe were nearly coincident with those on the chart; and in the northern hemisphere four zero lines appeared similarly coincident; two of which lines on the North American and European continents were continuations of those in the southern hemisphere. But the most remarkable and unexpected feature of the distribution of the magnetism on the iron-covered globe was the reproduction of the oval area of small westerly declination in Eastern Asia ( $110^{\circ}$ — $160^{\circ}$  E.), surrounded by large areas of eastern declination. The oval also agreed in detail with that on the chart in having the largest westerly declination, about  $8^{\circ}$  in the centre, between the lines of no declination.

Scarcely less interesting was the unlooked-for reproduction of the oval area of small easterly declination, about  $5^{\circ}$ , surrounded by a large area of greater eastern declination in the equatorial parts of the Pacific ( $120^{\circ}$ — $170^{\circ}$  W.), while the unsymmetrical form of the magnetic equator was very similar in its deviations to that of the earth for the epoch 1880.

Further experiments with the iron-covered globe showed that the land areas, besides retarding the translatory movement of the lines of the declination, generally diminished the amplitude of the declination itself, and to a greater amount as the broad features of the continental coast lines extended more or less in a direction parallel to the earth's equator.

On the other hand, continental coast lines extending more or less parallel to the earth's axis and terminating in capes or headlands, diminish the horizontal force, and, consequently, increase the rate and range of the declination; as instanced:—(1) In the large amount of the secular change along the South African coasts, where at the Cape of Good Hope the declination is  $30^{\circ}$  W. (2) On the South American coasts about Cape Horn,  $20^{\circ}$  E. (3) On the Greenland coasts at Cape Farewell,  $50^{\circ}$  W. (4) The coasts of Southern India

at Cape Comorin, where the declination was  $16^{\circ}$ W. in the year 1601, and is now  $1^{\circ}$ E.

The observations of deep-sea temperatures made during recent years have brought out the important fact that, at great depths, the temperature of the ocean beds is little above the freezing point of water. Prestwich and others have inferred that this low temperature of ocean depths is competent to produce a greater thickness of the earth's crust under the oceans than under the land. The large amount of iron which enters into the composition of the earth's crust is well known from the analysis of volcanic ejections from all parts of the globe, while at extreme depths this element exists in the metallic state, as at Ovefak, off the coast of Greenland, where it is found diffused in the basaltic rocks and in separate masses. We have, therefore, through the low temperature and increased thickness of the ferruginous ocean beds, the precise conditions required for producing the differences in the magnetic elements which have been shewn on the mapped globe when the ocean areas were covered with iron.

Now that the great influence which the land areas exercise in retarding the translatory motion of the lines of the declination has been shewn, which is distinct from the magnetism of local geological formations, the same influence in determining the form and position of the declination lines on the terrestrial surface becomes very apparent on the charts. An important negative feature of this influence is the symmetry and simplicity of the declination lines in the southern hemisphere, where the ocean completely encircles the globe in latitude  $60^{\circ}$ , as compared with the devious lines of the declination on the great land areas in the same latitude of the northern hemisphere.

The dominant influence of longitudinal coast lines is well seen in the bend of the zero and other declination lines towards the north pole of the earth's axis in their westerly



march over Europe ;—the effect of the intersection of the land areas by the basin of the Mediterranean and other great inland depressions, extending more or less parallel to the equator over  $60^{\circ}$  of longitude. The polarising effect of the arctic coast line appears in the small amount of the declination at St. Petersburg, which has not varied more than  $8^{\circ}$  during the last 150 years. The polarisation of the coast lines is again seen on the chart at the shoulder of the South American continent at Pernambuco, where the lines bend upwards towards the polar axis, and resume their westerly direction in the Carribean Sea and in the basin of the North Atlantic. Strong polarising effects, to diminish and retard the declination, are also produced by the longitudinal coast lines of the Gulf of Mexico, the West Indian Islands, the north and south coasts of Australia, the great coast lines within the Antarctic circle, the Malayan Archipelago and the southern coasts of India and China. So great is the polarity of the West India Islands, that the secular change of the declination at Jamaica and Cuba has not amounted to more than  $3^{\circ}$  during the last 200 years. From a comparison of the zero lines of declination of the internal electro-dynamic sphere in relation to the earth's axis and to the zero lines on the terrestrial surface, it will be seen that the appellation of magnetic poles and zeros of declination applies with strictness only to the poles of the earth's axis, and to the poles and meridians of the internal electro-dynamic sphere, as the zeros of declination on the earth's surface, for the present epoch, are generally the resultants of the changing electro-dynamic and permanent magnetic forces acting through and upon the outer crust of the terrestrial globe.

An interesting instance in confirmation of my views and experiments on the polarising action of longitudinal coast lines which I desire to bring before the Society, on account of its importance to practical navigation, was brought to

light during the Admiralty enquiry into the causes that led to the disastrous loss of H.M.S. "Serpent" off Cape Villano, on the coast of Spain, November, 1890.\*

Among other reports read before the Court was one from the captain of the Spanish screw steamer "Beneta," who stated that, during the 15 years he had been trading along the north coast of Spain, he did not remember to have observed any deviation of the compass on account of the attraction of the iron ore mountains, but he always noticed that when steering on a southerly course the error of the compass was N.E. ; that was to say, that the local variation of the compass was eight or ten degrees N.W. instead of 18 or 20 degrees as shown on the Admiralty chart of the declination. Now, a glance at the chart will show that the north coast of Spain extends parallel to the earth's equator for a distance of nearly eight degrees, or 400 miles, and has, consequently, a maximum polarising influence on the compass to diminish the amount of the secular change of the declination, as observed by the captain of the "Beneta" and as set forth in my papers.

It would therefore appear that some of the declination lines, as represented on the charts, do not partake of that symmetrical character that is generally accorded to them and that caution will be required in the use of variation charts off the greatly extended coast lines of deep seas where the rate and range of the secular declination are large in amount.

---

\* The London *Times*, December 17th, 1890.

FOR THE

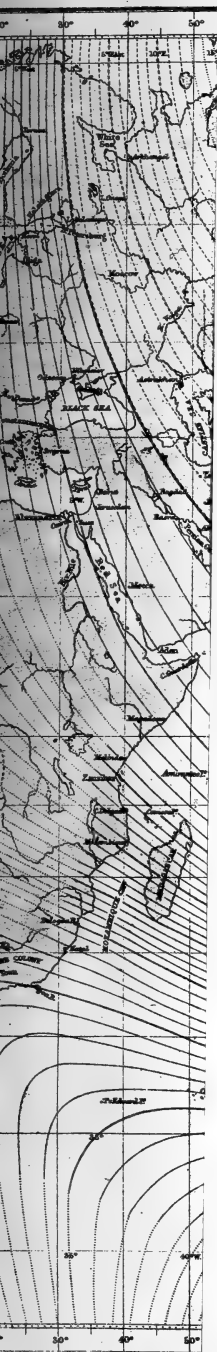



# CURVES OF EQUAL MAGNETIC VARIATION FOR THE EPOCH 1880.

4th SERIES, VOL. VIII.

PLATE X.—Influence of Coast Lines on Magnetic Declination.

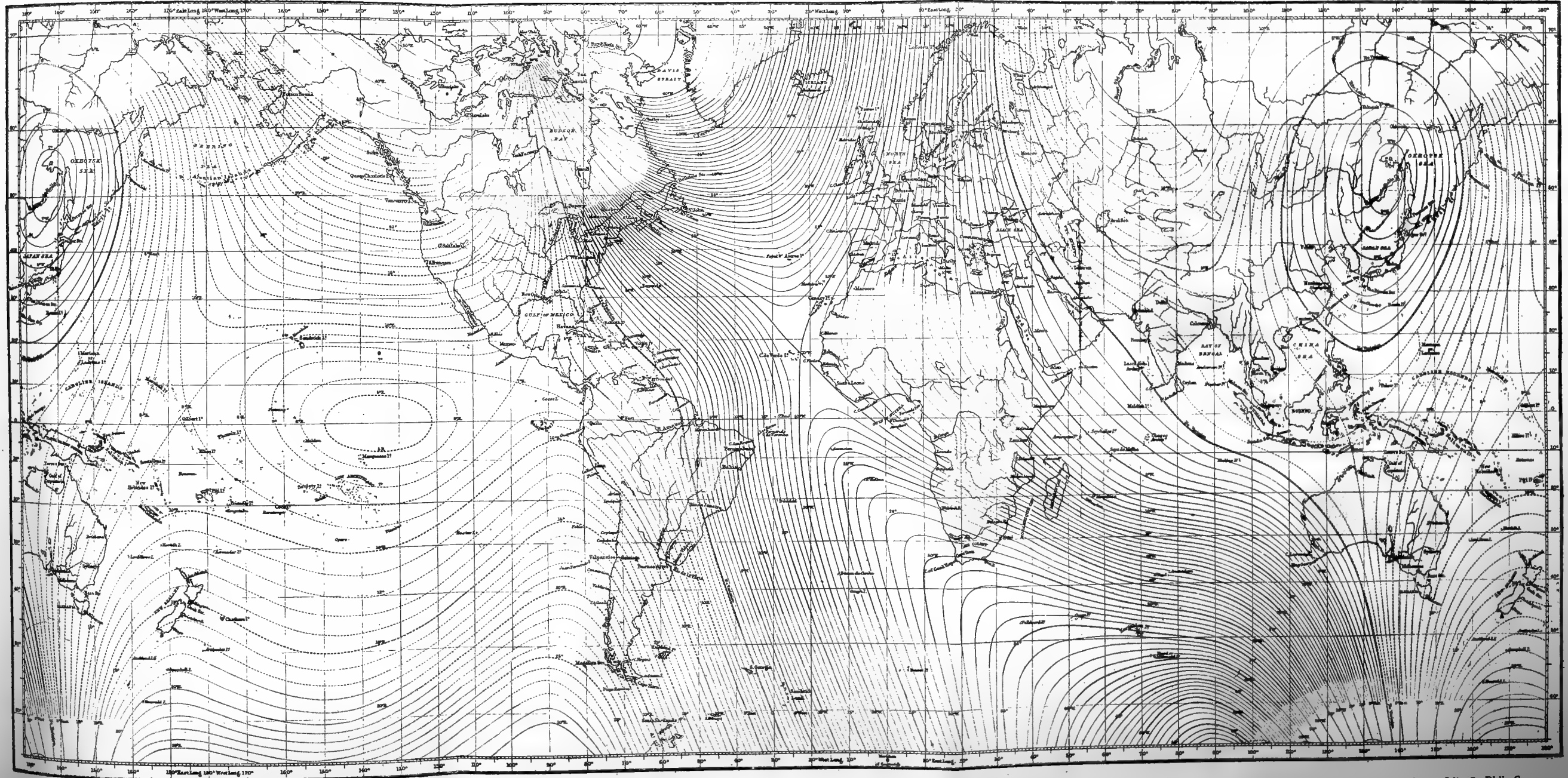

| No. | Name            | Age | Sex | Profession | Religion     | Marriage | Children | Notes |
|-----|-----------------|-----|-----|------------|--------------|----------|----------|-------|
| 1   | John Smith      | 35  | M   | Farmer     | Methodist    | Married  | 3        |       |
| 2   | Mary Jones      | 32  | F   | Homemaker  | Methodist    | Married  | 3        |       |
| 3   | Robert Brown    | 40  | M   | Teacher    | Baptist      | Married  | 2        |       |
| 4   | Sarah White     | 28  | F   | Homemaker  | Baptist      | Married  | 2        |       |
| 5   | James Green     | 50  | M   | Blacksmith | Presbyterian | Married  | 4        |       |
| 6   | Elizabeth Black | 45  | F   | Homemaker  | Presbyterian | Married  | 4        |       |
| 7   | William Gray    | 30  | M   | Merchant   | Methodist    | Married  | 1        |       |
| 8   | Anna Hill       | 25  | F   | Homemaker  | Methodist    | Married  | 1        |       |
| 9   | Thomas Lee      | 60  | M   | Retired    | Methodist    | Married  | 5        |       |
| 10  | Rebecca King    | 55  | F   | Homemaker  | Methodist    | Married  | 5        |       |

**A Sketch of the History of the Canal and River Navigations of England and Wales and of their present condition, with suggestions for their future development. By Lionel B. Wells, M. Inst. C.E. Communicated by Rupert Swindells, M. Inst. C.E., F.R.G.S.**

*(Received November 14th, 1893.)*

For some years public attention has been attracted to the condition of inland navigation in this country.

The extraordinary success of the Suez Canal, opened 24 years ago, the construction of the Ship Canal from Amsterdam to Ymuiden, and the success of the efforts to improve the navigation of estuaries, such as the Clyde and the Tyne, have demonstrated the advantages to be gained by the use of inland water transit. Moreover, the keenness of trade competition among nations and individuals has compelled merchants and manufacturers to consider the necessity of cheapening to the utmost the cost of carriage. The above are the chief, among many, causes, that have of late years recalled attention to the system of locomotion which served our forefathers before the development of railways; a system which was exemplified in our neighbourhood by the construction of the Bridgewater Canal, from the coalfields, near Worsley, to Manchester, and *vid* Runcorn and the estuary of the Mersey to Liverpool. This canal was at the time of its construction a great advance on the means of locomotion, and its completion was due to the enterprise and self-denial of the last Duke of Bridgewater, and to the skill and perseverance of the great Canal Engineer, James Brindley.

A great cheapening of the cost of carriage, an expansion

of industry, and a princely fortune for "the Duke," were the immediate results of the opening of the canal.

A list of Acts of Parliament affecting inland navigation in England, prepared by the late Mr. Conder, M.Inst.C.E., commences with an Act referring to the Thames, dated 1423, followed by Acts dealing with the Lee, in 1425, and the Yorkshire Ouse, in 1462. These are the earliest legislative records on the subject of waterways—Three in the XV. century. In the XVI. century we find seven; one referring to the River Exe, dated 1536, while the term canal is first mentioned in 1572 in relation to the navigation made at Exeter, by the citizens of that place, when the woollen trade was flourishing in Devonshire. This waterway is also notable as having been widened and deepened, to accommodate sea-going vessels, upwards of 60 years ago.

There are Acts relating to 23 river navigations during the next 150 years, but no canal is again mentioned until 1720, when the name of the Leeds and Liverpool Canal appears side by side with that of the Mersey and Irwell and River Weaver Navigations.

From 1700 to 1760, 29 Bills were promoted in Parliament, only 3 of which referred to new canals; the remainder referred to the improvement of river navigations.

The Bridgewater Canal was opened to Manchester in 1762, and through to the Mersey in 1776. Following this, during the last 40 years of the 18th century, Acts of Parliament were applied for concerning 85 new waterways. Only 16 of these referred to rivers, while 69 were for canals, which had become popular at this period. In the year 1794 no less than 12 canal Bills were recorded. Subsequently there was a falling off; and from 1800 to 1830 we find only 40 applications for new waterways, while from 1830 until 1883, when the Manchester Ship Canal Bill was promoted for the first time, the Severn Navigation Act is the only one of importance to be noticed.



The above shows how completely enterprise in inland waterways has stagnated during the 19th century. The proprietors have neglected to keep pace with the requirements of trade. In fact, with the exceptions of the navigations of the Weaver and Aire and Calder, which have been re-modelled, and certain improvements in detail on a few others, little or nothing has been done to enlarge or improve our waterways. In many instances they have been allowed to fall into decay, and some have been abandoned or converted into railways. Steam haulage has been adopted on only a few of the more progressive.

The importance of inland navigation faded as the construction of railways was proceeded with, although for some years its influence on trade remained very considerable.

In the middle of the last century Bolton was the chief seat of the cotton industry. It was the improved means of transit afforded by the Bridgewater Canal, in competition with the Mersey and Irwell Navigation, that enabled Manchester to take the lead, and although situated on the fringe of the district, Manchester has now for many years continued to hold the first place in the cotton trade.

It will be observed that the commercial prosperity following on the completion of the Bridgewater Canal was the signal for much activity in canal construction, and it is worthy of remark that what may be termed the canal era synchronises with the great development of manufacturing industry in this country.

Before 1830 a network of canals overspread the kingdom, as shown on the map before you. This map, 6·9 miles to the inch, has been reproduced on a scale of  $\frac{1}{4}$  the original. The canals were, unfortunately, constructed without any regard to system, and locks were built of various dimensions, so that boats of a uniform burthen were prevented from trading for long distances. Through routes were in the hands of several distinct companies, whose sole object was

to make as much as possible out of each cargo, having no idea of fostering trade by liberal treatment, or by acting on enlarged views of its coming development. In spite of this drawback the Companies prospered as a whole, and did good service. Railways and tramways were first made with a view to establish communication between waterways and places which from physical causes were inaccessible to canals. It was only after trams had been used for this purpose, that the adoption of flanged wheels for the trucks and carriages, and the use of the steam blast, disclosed to engineers the new power at their disposal.

Railways were speedily recognised to be capable in many particulars of equalling and surpassing locomotion by water.

Canal navigation was at its best from 1820 to 1840, but from that time forward until quite recently enterprise in this direction became extinct. The marvellous increase in general trade is meanwhile indicated by the tonnage of shipping entered and cleared from British ports ; a return of which has been furnished by the Board of Trade, commencing with 1840 and covering the next 50 years. This return shows the tonnage of vessels entered from the ports of the United Kingdom in 1840 as

|                 |     |     |     |     | TONS.            |
|-----------------|-----|-----|-----|-----|------------------|
| British Vessels | ... | ... | ... | ... | 6,490,485        |
| Foreign Vessels | ... | ... | ... | ... | 2,949,182        |
| Total 1840      |     |     |     |     | <u>9,439,667</u> |

in 1889 as

|                 |     |     |     |     | TONS.             |
|-----------------|-----|-----|-----|-----|-------------------|
| British Vessels | ... | ... | ... | ... | 52,469,654        |
| Foreign Vessels | ... | ... | ... | ... | 19,420,241        |
| Total 1889      |     |     |     |     | <u>71,889,895</u> |

During this period the Mercantile Steam Marine may

be said to have been created, for in 1840 the British-owned steamers entered and cleared

|                  |      |     |     |     | TONS.          |
|------------------|------|-----|-----|-----|----------------|
| Amounted to...   | ...  | ... | ..  | ... | 663,048        |
| Foreign Steamers | .... | ... | ... | ... | 128,507        |
| Total            |      |     |     |     | <u>791,555</u> |

In 1889 British-owned steamers entered and cleared

|                  |     |     |     |     | TONS.             |
|------------------|-----|-----|-----|-----|-------------------|
| Amounted to      | ... | ... | ... | ... | 47,020,297        |
| Foreign Steamers | ..  | ... | ... | ... | 11,743,903        |
| Total            |     |     |     |     | <u>58,764,200</u> |

The tons given are tons register, and, as a steamer carries more cargo in proportion to her registered tonnage than a sailing vessel, the increase in the tons of cargo dealt with is proportionately greater than the actual figures shew ; moreover the dead weight carried by all vessels is very much in excess of their registered tonnage.

Not one of the old waterways has secured its due proportion of this enormous increase of traffic. As already stated, some few navigations are largely used, but on many traffic has dwindled, while lines of railway have been laid along the course of a few and others have been completely closed. The use of steam is confined to a few waterways, while on many it is prohibited.

It is a matter of extreme regret that the Select Committee on Canals, appointed in 1883, did not complete its labours. It sat for 10 days, and heard the evidence of some of the most experienced of canal managers, engineers, and others, both those interested in and those unfavourable to the development of waterways. The Committee was not re-appointed, and did not report. The evidence was printed, and has provided most valuable information on the subject.

On the Continent opinion on the use of waterways has ripened more quickly than in England, great improvements and extensions have been made, and a far-reaching interest with regard to them has been aroused. In Germany, for instance, the internal water-borne traffic increased by 65% from 1875 to 1885, and at the present time 23% of the whole internal traffic of the country is carried by water; while in France the increase from 1879 to 1888 was 57%. An International Congress was formed, and held its first meeting at Brussels in 1886. It meets biennially, and the fourth meeting was held in this city in 1890, when the Congress numbered 492 members. At this Congress no map of the waterways of England was forthcoming, and it occurred to a member of this Society, Mr. Swindells, M.Inst.C.E., as well as to myself, that this was a serious omission. We, therefore, agreed to do our best to prevent its recurrence. The result of our efforts is the map now exhibited, drawn to a scale of  $\frac{1}{437200}$ , or 6.9 miles = 1 inch. I only wish I could speak with as much confidence as to the accuracy of the whole of the information for which I am responsible, as I can to the excellence of the workmanship which Mr. Swindells has displayed. I have, however, done my best under existing circumstances. The map was prepared for the 5th Congress, and was exhibited at its meeting held last year in Paris.

The question of transit is so important to the commercial interests of the nation that the Board of Trade will doubtless be compelled to obtain a more accurate knowledge of the facts relating to navigable rivers and canals and their present condition, with a view to action being taken for bringing more fully into use these long neglected trade routes.

In 1890 two Bills were, and this year one Bill has been brought before Parliament, dealing with the development of canals and their control by local authorities. These

were the outcome of a great deal of thought and discussion, but the question is evidently not yet ripe for legislation. The still greater question of the Nationalisation of Inland Navigations in this country has yet to be decided—a question which has been decided in France by the Government obtaining possession of  $\frac{6}{7}$ ths of the mileage. This proportion has for some years been toll free. A small toll is levied by the State in Belgium.

At the Congress held in Manchester, Mr. Clements, Secretary of the Railway and Canal Traders' Association, read a paper of great interest dealing with the question of Inland Navigation, more especially from a trader's point of view. He based his figures upon the latest official information, viz., a Board of Trade return for the year 1888, which return, however, is in many respects incomplete, as it has omissions and inaccuracies such as might well be expected, seeing that it is the first return which has been called for on a somewhat complicated subject. Further statistical information is much needed. Before this return was published the information obtainable was most meagre, and the return still leaves much to be desired. The names of many canals are missing altogether. It distinguishes generally the waterways owned by independent companies from those owned by railway companies. Some, however, especially among the latter, make incomplete returns. No column is provided for particulars of the headway under bridges, and frequently no distinction is made in lengths of portions of the waterway differing in navigable depth, &c. The difference in statements made by various companies under the head of maintenance of works, management, &c., shew the great need for editing the returns. The figures for the Lancaster canal show an average of £49 per mile per annum, of the Shropshire Union to £539 per mile per annum. Among the independent navigations, the Severn shows an expenditure of £125, and the Weaver

£2,070 per mile per annum, for apparently identical purposes. No useful information can be gathered from such figures as these.

Many of the waterways of the first importance from the traders' point of view have been, as already stated, secured by railway companies, who are thus enabled to exercise an undue control, and so to prevent active competition between the water and land traffic.

A reference to the map, on which the canals controlled by railway companies are shown by a red line, those which are independent by a blue one, makes this evident. Around Manchester, Birmingham, and from Sheffield to the sea, also in the colliery districts of South Wales, the waterways have been to a great extent acquired by railway companies.

On the map a distinctive number is attached to the canals belonging to each separate company; and by referring to the table at the bottom, the name of the canal will be found as well as the length; also information as to its ownership by railway companies. If known to be derelict or abandoned, this is stated. Ship canals are noted.

The capacity of the various waterways is to some extent indicated by the thickness of the lines drawn to represent their course. Five different lines are employed:

1. To represent a canal for narrow boats.
2. Do. do. barges.
3. Do. do. improved barge canals 6ft. 6in. deep and upwards.
4. Do. ship canals from 13ft. to 18ft. in depth.
5. Do. the Manchester Ship Canal.

Of the 3,935 miles, 140 miles have been converted into railways, and 275 miles are derelict or abandoned, leaving 3,520 miles of navigable waterways.

Of this mileage the independent companies own 2,256 miles, and the railway companies 1,264 miles, more than one-third of the total length of the existing inland waterways.

The railway-controlled navigations and canals, as we have seen (*vide map*), are, many of them, in most favourable situations for securing traffic. Nevertheless, out of the total tonnage of 34,121,230 tons returned in 1888, the railway-controlled canals are credited with only 6,609,304 tons, *i.e.*, less than  $\frac{1}{5}$ . This makes it very clear that they are not carrying the tonnage which their position should secure for them, and proves the necessity for a far-reaching change.

There are four ship canals, including the Manchester Ship Canal, which will be  $35\frac{1}{2}$  miles long and 26 ft. deep: the three others are 18 ft. deep or less. When the canal to Manchester is finished the total length of ship canals will aggregate  $58\frac{1}{2}$  miles. The remainder of the waterways navigable by craft drawing 6ft. 6in., and in some cases 9ft. 6in., are eleven in number, and have a total length of about 230 miles.

These are all rivers canalised for the purpose of navigation. The more important ones are the Weaver, the Aire and Calder, and the Severn; all of which are independent. The Weaver and Severn navigations are in the hands of Public Trusts. The Aire and Calder is a trading company. The improved sections of these three waterways extend for an aggregate length of 107 miles, and their united traffic amounted in 1888 to upwards of 4,000,000 tons, averaging upwards of 36,000 tons a mile. The tonnage carried was therefore between  $\frac{1}{8}$  and  $\frac{1}{9}$  of the total carried by all the rest of the inland navigations, and approximately  $\frac{5}{8}$  of the total tonnage carried by the railway-controlled waterways. The latter are given in the return as 1,024 miles long. Therefore, on nine and one-half times the length of waterway, they carry only 65% more traffic.

The barge canals, which accommodate craft 70 ft. long and 14ft. beam, carrying 40 to 50 tons, are in the aggregate 2,040 miles in length; and the narrow canals, whose locks provide for boats of about the same length, with 7ft.

beam, or less, and carry cargoes of from 18 to 30 tons, according to the draft of water, aggregate 1,240 miles. The capacity of a narrow canal efficiently worked is shown by the Birmingham and Warwick Junction, which is only  $2\frac{1}{2}$  miles long, and has a single line of six locks in that short distance. It carries, nevertheless, 195,000 tons per annum.

It is noticeable that, with scarcely an exception, the sills of the locks are well below the navigable draft of the waterway, proving clearly that a much better route could be provided, and was intended to be provided by the founders of the Canals.

This is a matter of vital importance, for every additional inch of draft allows of an additional ton of cargo being carried by a narrow canal boat ; and as the other expenses, including haulage, are scarcely affected by the weight added, the addition is almost clear gain to the merchant or carrier.

The same horse will haul at an equal speed a narrow boat loaded with 20 tons on a narrow canal, a barge loaded with 40 to 50 tons on a well-maintained barge canal, or a vessel loaded with 100 tons on a 10ft. waterway, such as is provided on the Weaver. Two horses haul 200 tons and upwards on this navigation ; but the large barges from 200 to 350 tons are, as a rule, propelled by steam or towed by a steamer. On the Continent canal barges, carrying 250 to 300 tons, are hauled by two horses.

Not long since the condition of our inland waterways was not inaptly termed one of creeping paralysis. The advent of the railways alarmed most of the Companies, and Parliament hastened to assist in their degradation by handing them over wholesale to the control of their rivals. In the session of 1846 alone 17 Acts of Parliament were obtained, by which 776 miles of waterway passed under the control of railway companies. It is not, therefore, surprising that we



look in vain on the map for any extended through route in the hands of a single independent company.

In proceeding from London to Birmingham a boat traverses canals owned by five companies, and cannot enter the latter city, or circle round it, without passing over a canal controlled by a railway company. Manchester was served by the Bridgewater, as Leeds is by the Aire and Calder Navigation, but in 1872 the Bridgewater Canal passed virtually under railway control, although nominally purchased for an independent company, and was redeemed at an increased cost of 100% by the Ship Canal Company in 1887.

The waterway from Sheffield to the Humber is in the hands of the Manchester, Sheffield and Lincolnshire Railway Company, but so much dissatisfaction was aroused at the condition of the navigation that in 1889 an Act of Parliament was obtained enabling an independent company to compel the railway company to sell the navigation to it, at a price to be fixed by the Railway and Canal Commissioners.

This is a sign that the paralysis is checked and a healthier feeling is aroused. Such a move made in the right direction should be followed up until the rest of the waterways are divorced from railway control and management.

At the present time 43 navigable waterways are controlled by 13 different railway companies. The London and North-Western Railway Company controls 6 canals, having a total length of 460 miles, including the shortest route between Birmingham and the Mersey ports; while by its hold over the Birmingham Canal Company the North-Western Railway Company has its grasp upon 159 miles of the most important narrow canals in the centre of England. The Great Western Railway Company controls no less than 12 canals; but the length of these is no more than 260 miles, including, however, the Kennet and Avon Canal, which is the most desirable route between the Thames and the

Bristol Channel ; also the Thames and Severn Canal, and thus cuts through communication between the estuaries of those rivers. This Company also owns important canals in South Wales. There are upwards of 130 different lengths of waterways, and more than 100 proprietors. It would be to the public advantage that many of these should be amalgamated. By this means through routes from east to west and north to south could be established.

Under a recent Act of Parliament through rates and tolls can be demanded by traders for the carriage of goods on different waterways at the hands of the Railway and Canal Commissioners ; but the process is so tedious and expensive that traders seldom feel themselves in a position to make application.

It is expected that the enquiry into canal rates and tolls now being held will result in a simplification of charges and the removal of the additional tolls levied on passing from one company's system to another, known as bar tolls ; and that, under amended conditions, a considerable increase of traffic will ensue. This should, however, be succeeded by amalgamation and the establishment of a canal clearing-house.

The great railway companies have secured their position by amalgamating numerous companies into their systems. The London and North-Western is an aggregation of some 50 separate undertakings. Nothing comparable with this has been accomplished by canal companies ; with few exceptions they remain isolated, and in many instances any attempt at amalgamation on important routes would now be impossible, owing to the intervention of a waterway owned by a railway company.

Having noticed some measures, which, if adopted, would facilitate the transit of goods by water, the question of the enlargement and improvement of the channels demands consideration, and from experience gained in this country and

on the Continent, it is clear that many of our canals and navigations would well repay a judicious outlay of capital. We find the improved Aire and Calder Navigation competing with the railways from Leeds and Wakefield, and carrying 2,200,000 tons of traffic annually. Regular lines of steamers are loaded at Goole for London, although there is direct railway communication between the manufactories at Leeds and the Metropolis. The Bridgewater Canal, on which steam haulage has been largely developed for 15 years or more, competes with three railway companies for the traffic between Manchester and the South Lancashire colliery districts, and between Manchester and Liverpool, and carries 2,500,000 tons per annum; and in France, although only one-half the waterways have as yet been brought into the first class, 92% of the internal water-borne traffic is carried on these, leaving only 8% for an equal mileage of inferior sections.

Much may be learnt from what has been done in France. Throughout the country the length of waterways available for inland navigation approximates 8,000 miles. Of this 650 miles are returned as tidal, 2,100 miles navigable without works, 2,250 miles canalised rivers, 3,000 miles canals. All are toll free, with the exception of about 600 miles, a little over 7% of the entire length; of those not under State control about one-half are under temporary concessions, some of which, however, do not expire until 1960.

Prior to 1792 canals were made by private enterprise under concessions. But at the Revolution they were declared public property, and all rights were confiscated. Subsequently, in order to raise money for warlike purposes, many of them were sold. After the Restoration, from 1814 to 1830, 500 miles of new canals were made under Government supervision, and during the reign of Louis Philippe, at the time when enterprise in canals stag-

nated in England, 1,200 miles of canals were constructed and improvements made on a great number of navigable rivers. In 1847 the tolls levied amounted to £400,000 per annum. The Government then decided that the time had come for taking over the control and management of waterways. In the earlier days of the Second Empire it was decreed that several of the chief lines of canals should be purchased at once by the State. At this time railway construction was proceeding rapidly in France, but instead of handing over the competitive routes to the railway companies, the repurchase of waterways by the State was kept steadily in view. By a decree of 1852, definite lines were laid down for determining the prices to be paid for them under arbitration.

It was not, however, until after 1863 that the powers of repurchase were exercised to the full extent, and by 1869 the work had been completed, and a decree was made fixing low rates of tolls for two different classes of waterways. These tolls continued to be levied on the State canals until 1880, when they were abolished, and the canals made free.

The Minister of Public Works publishes for sale an official guide of the internal navigation. Much of the information contained in the guide is graphically represented on a map accompanying it, which shews approximately:— (I.) The character of the waterways comprised in the French system. (II.) The general conditions of navigation on them. (III.) The lengths of various waterways, and of distances from place to place on the principal lines of traffic. (1.) The waterways are distinguished, according to their character, as canals or rivers, as defined in the Official Guide. The portions floatable are coloured. (2) The waterways are divided into two classes. In the first class are all those of which the depth is 2 metres (6ft. 6½in.) and upwards, and the locks not less than 38·5 metres (126ft. 3in.)

long and 5·20 metres (17ft.) broad, accommodating barges of 250 to 300 tons. All others are placed in the second class. (3) In reference to distance the map gives: (*a*) The distance between intermediate points, centres of trade and junctions; (*b*) the total length of navigations, or portions thereof, from the terminus; (*c*) the distance from the origin of the system, whether taken from Paris, Nantes, or Bordeaux. Special maps, to a larger scale, show the canals to the north, the manufacturing district; also in the neighbourhood of Paris and Nancy.

The letterpress of the guide is divided into five parts:—

(1) Sets forth the decrees and regulations binding upon the officials and the public. (2) An alphabetical list of all the waterways, giving, in a tabular form, the length, depth, number and size of locks, number of bridges and tunnels, with the headway available under these; also additional observations as to the depth when variable, and other information useful to the navigator. (3) A table of distances along each route, giving the principal places and distance from the starting point of the system, the facilities offered for navigation, the class of boats in general use, the regulations in force, and other information of a kindred nature. (4) An alphabetical list of the places mentioned in the table of distances, with a reference to the page on which they are to be found. (5) Longitudinal sections of the principal waterways to scale, showing the position and number of the locks, coloured to show which are river and which are canal navigations.

In both Belgium and Holland the waterways are maintained in a high state of efficiency. The Governments of these countries also publish a canal guide, which gives full particulars of the navigation, enabling a merchant or boatman to act with confidence in any question of conveyance by water, not only within the State but across the frontiers of adjoining nations. I have brought these for inspection. In England,

where there are so many companies, we have no directory giving their offices. There is no uniformity of regulations or bye-laws, and no ready means of ascertaining any of the conditions under which navigation is practicable. Personal experience, which is necessarily limited in extent, and possessed by but few people, is the only reliable guide, and yet our waterways are returned as carrying 50% more traffic than those of France.

It seems clear that if ordinary facilities were obtainable, the growth of traffic would be commensurate, and that independent waterways and improved channels would go far in solving the vexed question of railway rates; for it is always open to an aggrieved trader to place boats of his own on the waterway and become a carrier. The fact that there is an independent route along the Severn Navigation and the Worcestershire and Birmingham Canal has secured for Birmingham a lower railway rate to the Bristol Channel ports, than is obtained from the Mersey. The distance to Liverpool is less, but the canals in that direction are in the hands of railway companies. Even now the sea and the canals are the important factor in determining rates of carriage, and have been so acknowledged by the dictum of that great authority, the late Chairman of the L. and N. W. Railway Company.

Facilities for locomotion and cheap locomotion are essential to trade, and the enhancement of the prosperity of a district benefits the entire community. Competition does not necessarily mean loss. There is traffic for which railways are best adapted, and other traffic best served by canals. The improvement of the navigation to Frankfort-on-the-Main has not lessened, but has increased, the traffic on the railways serving that city.

Obviously any information tending to elucidate the subject and interest the public in the problem of how to deal with our inland navigations to the best advantage is of national importance.

Considering the part taken by the citizens of Manchester and their representatives in promoting and completing their Ship Canal, it is evident that we are all pledged to the careful consideration of this problem. As a result of the exertions above mentioned, which have called forth admiration at home and abroad, this city will shortly become a seaport, and situated as it is at the junction of five canal systems, it follows that there is no district that has so immediate and direct an interest in the best and quickest solution of the question as Manchester.

The revision of canal rates and tolls has recently been under the consideration of the Board of Trade, and a committee formed of members of both Houses of Parliament. In the statements laid before these tribunals a mass of new and important information bearing upon the subject of inland navigation has been made public property. When this enquiry is completed, no valid reason can, in my opinion, be urged for further delay in the preparation of accurate statistics, such as will provide material from which a reliable estimate can be formed as to the present position, and the position to be occupied in the future by our inland waterways, as well as their importance to the trade of the country.

As five years have elapsed since the last return was made, a return for 1893 should be ordered by Parliament, and the Board of Trade should make certain that all necessary information for defining the capacity of the various waterways, and especially with regard to through routes, is included in it.

It is necessary that this information should be carefully considered by an expert before it is printed, so as to avoid a recurrence of misleading statements, too many of which are to be found in the 1888 return.

Our representatives abroad should be requested to pay particular attention to the internal navigation of foreign

countries during next year, and from them we may expect many valuable contributions to our knowledge of the subject, such as is afforded by No. 241 Miscellaneous Series of Reports published by the Foreign Office in 1892, by Mr. Consul O'Neill, which treats of the harbour improvements at Rouen and the navigation of the Seine.

Having thus collected information from all quarters, the Board of Trade should either formulate a proposal for dealing with the question, or a Commission should be appointed to take evidence, before which the Board of Trade representatives would appear as witnesses, together with other qualified persons.

The whole subject would then be fully considered under its numerous aspects, and a valuable report, on which action could be taken with a great degree of confidence, should be the result.

Fortunately politics have nothing to do with the question; it is a pure matter of business, and should be so regarded.

Lancashire and Manchester have plainly expressed their views of the necessity for cheaper carriage by constructing the Manchester Ship Canal; and I hope this example will induce action to be taken in respect to inland waterways throughout the country.

It is clear that they are more cheaply made and maintained than railways, and that for certain descriptions of traffic they can be employed with an equal or greater advantage, and with far greater economy.

---



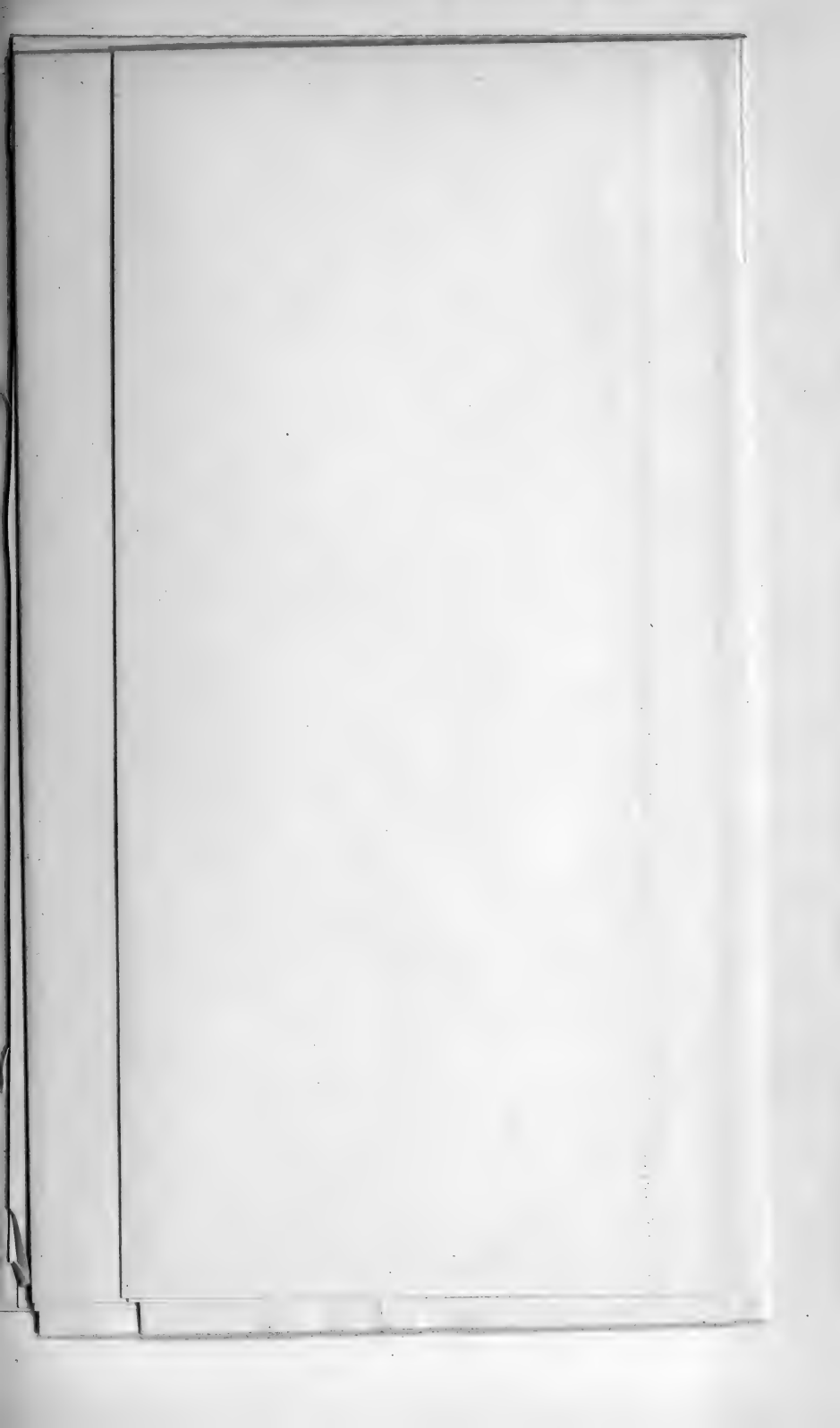





**MAP OF  
CANALS  
AND  
NAVIGABLE RIVERS  
OF  
ENGLAND & WALES**  
BY  
**LIONEL B. WELLS, M. INST. C. E.**  
LATE ENGINEER TO THE RIVER WEAVER NAVIGATION

**Explanation.**

- Canals Coloured BLUE are Independent.
- Canals Coloured RED are Railway Controlled.
- Canals to accommodate Narrow Boats, shown thus: [Symbol]
- Canals to accommodate Barges, shown thus: [Symbol]
- Canals to accommodate Barges above 6 feet draught, shown thus: [Symbol]
- Ship Canals, shown thus: [Symbol]
- Manchester Ship Canal, shown thus: [Symbol]
- Canals converted into Railways, abandoned, or derelict, shown thus: [Symbol]

LIONEL B. WELLS, M. Inst. C.E.  
R. SWINDELLS, M. Inst. C.E., F.R.O.S.  
Manchester.

**LIST OF CANALS AND INLAND NAVIGATIONS—TOTAL LENGTH 3,935 MILES.**

| No. on Map | NAME                                | Length in Miles | Independent | No. on Map | NAME                        | Length in Miles | Independent | No. on Map | NAME                                                 | Length in Miles | Independent | No. on Map | NAME                                                 | Length in Miles | Independent |
|------------|-------------------------------------|-----------------|-------------|------------|-----------------------------|-----------------|-------------|------------|------------------------------------------------------|-----------------|-------------|------------|------------------------------------------------------|-----------------|-------------|
| 1          | Carlisle Canal                      | 11              | Independent | 23         | Leith Canal (Lincolnsheire) | 11 1/2          | Independent | 43         | Cromford Canal                                       | 17              | Railway     | 62         | North Walsham Canal                                  | 9               | Railway     |
| 2          | Liverpool Ship Canal                | 15              | Railway     | 24         | Anchor Navigation           | 10              | Independent | 44         | Essex Canal                                          | 17              | Railway     | 63         | Dimple Hill Canal                                    | 9               | Independent |
| 3          | Lancaster Canal                     | 60              | Railway     | 25         | Calder Canal                | 4               | Independent | 45         | Ware Navigation                                      | 18              | Railway     | 64         | Seven (above Elmsport)                               | 3               | Railway     |
| 4          | River Ouse Navig. (Yorkshire)       | 103             | Railway     | 26         | Trent Navigation Co.        | 65              | Independent | 46         | Natlock                                              | 18              | Railway     | 65         | North West of Navigation                             | 30              | Railway     |
| 5          | Ure (Boroughbridge and Ripon Canal) | 103             | Railway     | 27         | Forth                       | 16              | Independent | 47         | Loughborough Navigation                              | 67              | Railway     | 66         | Warney Navigation                                    | 9               | Railway     |
| 6          | Wharfe Navigation                   | 40              | Independent | 28         | Peak Forest                 | 15              | Independent | 48         | Oakham Canal & Wreak Navig.                          | 154             | Railway     | 67         | Blyth                                                | 15              | Railway     |
| 7          | Don Navigation                      | 91              | Independent | 29         | Sheffield Canal             | 40              | Railway     | 49         | Lancaster Navigation                                 | 15              | Railway     | 68         | Spawick & Slossmarket Navig.                         | 20              | Railway     |
| 8          | Derwent Canal                       | 91              | Independent | 30         | Peak Forest                 | 15              | Independent | 50         | Nar                                                  | 150             | Railway     | 69         | Hour Navigation                                      | 20              | Railway     |
| 9          | Market Weighton Navigation          | 91              | Independent | 31         | Macfield                    | 26              | Independent | 51         | Grave & Tributaries (Bedfordshire)                   | 150             | Railway     | 70         | Boles Navigation                                     | 20              | Railway     |
| 10         | Driffield                           | 7               | Independent | 32         | Stockport                   | 5               | Independent | 52         | Great Ouse Navigation (Bedfordshire)                 | 150             | Railway     | 71         | Chalmer & Blackwater Navig.                          | 20              | Railway     |
| 11         | Levens                              | 7               | Independent | 33         | Trout and Mersey Canal      | 150             | Railway     | 53         | North Metropolitan Ry. and Canal Co. (late Regent's) | 103             | Railway     | 72         | Boling Navigation                                    | 20              | Railway     |
| 12         | Reverley Beck                       | 3               | Independent | 34         | Gravelly                    | 21              | Independent | 54         | North Metropolitan Ry. and Canal Co. (late Regent's) | 103             | Railway     | 73         | Lea                                                  | 20              | Railway     |
| 13         | Arns and Calder                     | 143             | Railway     | 35         | Wear Navigation             | 200 1/2         | Railway     | 55         | Kennington Canal                                     | 74              | Railway     | 74         | Stark                                                | 24              | Railway     |
| 14         | Leeds and Liverpool Canal           | 91 1/2          | Railway     | 36         | Sheffield Union Canals      | 200 1/2         | Railway     | 56         | Grand Junction Canal                                 | 78              | Railway     | 75         | North Metropolitan Ry. and Canal Co. (late Regent's) | 103             | Railway     |
| 15         | Colne and Liverpool Navigation      | 91 1/2          | Railway     | 37         | Lillibald Company's Canal   | 143             | Railway     | 57         | Newport Pagdul                                       | 25              | Railway     | 76         | Grand Junction Canal                                 | 78              | Railway     |
| 16         | Kirkstall Canal                     | 34 1/2          | Railway     | 38         | Duke of Sutherland's        | 91 1/2          | Railway     | 58         | Warwick and Napton Canal                             | 77              | Railway     | 77         | Warwick and Napton Canal                             | 77              | Railway     |
| 17         | Thames and Oxford Canals            | 124             | Railway     | 39         | Mr. Ouse                    | 31 1/2          | Railway     | 59         | Warwick and Napton Canal                             | 77              | Railway     | 78         | Warwick and Napton Canal                             | 77              | Railway     |
| 18         | Avon and Birmingham Canals          | 151             | Railway     | 40         | Widban Navigation           | 31 1/2          | Railway     | 60         | Warwick and Napton Canal                             | 77              | Railway     | 79         | Warwick and Napton Canal                             | 77              | Railway     |
| 19         | St. Helens                          | 103             | Railway     | 41         | Sheffield Canal             | 11              | Independent | 61         | Warwick and Napton Canal                             | 77              | Railway     | 80         | Warwick and Napton Canal                             | 77              | Railway     |
| 20         | Manchester Ship Canal               | 42              | Railway     | 42         | Widban Navigation           | 31 1/2          | Railway     | 62         | Warwick and Napton Canal                             | 77              | Railway     | 81         | Warwick and Napton Canal                             | 77              | Railway     |
| 21         | Derwent Navigation                  | 91              | Railway     | 43         | Widban Navigation           | 31 1/2          | Railway     | 63         | Warwick and Napton Canal                             | 77              | Railway     | 82         | Warwick and Napton Canal                             | 77              | Railway     |
| 22         | Derwent Navigation                  | 91              | Railway     | 44         | Widban Navigation           | 31 1/2          | Railway     | 64         | Warwick and Napton Canal                             | 77              | Railway     | 83         | Warwick and Napton Canal                             | 77              | Railway     |



**Annual Report of the Council, April, 1894.**

The Society began the session with an ordinary membership of 124. During the session one former member has been re-admitted, and 7 new members have joined the Society; 7 resignations have been received and the deaths have been 6, viz. :—Mr. Thomas Armstrong, Dr. Charles Clay, Mr. Joseph Davis, Mr. W. K. Deane, Prof. A. Milnes Marshall, and Mr. Archibald Sandeman. This left on the roll on the 31st March, 1894, 119 ordinary members. The Society has also lost two honorary members by death, viz. :—Dr. John Tyndall and Professor H. Hertz.

The Treasurer's accounts, which accompany this report, detail the items of receipt and expenditure for the past session. The total cash balance in favour of the Society on the 31st March, 1894, was £244. 13s. 11d., that amount being in the hands of the Society's bankers on that date. At the corresponding period in the previous year the cash balance was £136. 8s. 4d., but this year an account for printing *Memoirs*, circulars, &c., amounting to £90 had not been adjusted and paid in time to bring it within the financial year; the payment of this account would have reduced the balance at the end of the session to £154.

The renovation of the Society's rooms and fittings, alluded to in the report of the Council of the previous year, was accomplished during the summer at a cost of £89. 5s. 3d., and as this expenditure was beyond the ordinary income of the Society, it was largely met by donations of £62. 0s. 6d. from eight members, as specified in the accompanying balance sheet. The thanks of the Society are due to these

friends for their kind gifts, and your Treasurer will be glad to receive further donations towards the same object.

The electric light installation, which was under consideration at the date of the last report, and the whole cost of which Mr. Henry Wilde, F.R.S., offered to bear, was accepted by your Council, and the work has been carried out during the year. This is another of many gifts made to the Society by the same generous donor. The cost of the work was £76, and the Society received from Mr. Wilde a donation of £100, the balance going towards the cost of repainting and repairing the Society's rooms and buildings. The electric installation does not supersede the existing gas arrangements, which are maintained as heretofore; but it is used as an adjunct to the gas supply, and as a ready means for applying the electric current for experimental purposes.

On November 26th, 1889 (Vol. III., p. 112), the Secretaries reported to the Society that, in response to the appeal of the Council, a Committee of citizens had been formed to secure the erection of a permanent memorial of Dr. Joule, then recently dead. Of this Committee, Mr. Alderman John Mark (then Mayor of Manchester) was appointed Chairman, the late Mr. Oliver Heywood, Treasurer, and Professor Osborne Reynolds, Mr. F. J. Faraday, and Mr. R. F. Gwyther, Hon. Secretaries. The Council has now to record that the marble statue of Dr. Joule, by Mr. Alfred Gilbert, R.A., was unveiled on December 8th last, by Lord Kelvin, the President of the Royal Society, and was presented to the Corporation of Manchester by Mr. Alderman Mark, the Chairman of the Committee, and accepted on behalf of the Corporation by the Lord Mayor, Mr. Alderman Marshall. The statue has been placed by the Manchester Corporation in the position which it now occupies, opposite the Chantrey statue of Dalton, in the vestibule of the main entrance of the Town Hall.

In February of last year, the Joule Memorial Com-

mittee invited the Council of the Society to send representatives to confer as to the best method of disposing of the surplus funds. The Council instructed its representatives at the conference to state that, in the opinion of the Council, the best method of disposing of the surplus funds would be to institute a permanent Joule Memorial Fund in connection with the Society, the income from which would be employed, as the Council might from time to time direct, for the encouragement and promotion of science. At the final meeting of the Joule Memorial Committee, it was resolved that, in accordance with this recommendation, the balance of the funds should be presented to the Society, to be used in commemoration of Joule's name, and at the same time the books and papers in connection with the Memorial should be deposited with the Society for safe custody to accompany the similar papers relating to the Chantrey statue of Dalton.

The books and papers referred to have been duly received, and also the sum of £257. 11s. od., the surplus of the subscriptions to the Joule Memorial; the Council has resolved to use this latter gift as the nucleus of a fund to carry out the wishes of the Joule Memorial Committee. It is the desire of your Council to see this fund augmented as opportunities occur.

After an existence of 114 years, the Society is still almost exclusively dependent on the subscriptions of its members. The Council, therefore, desires to call special attention to this fund. The occasion is the more appropriate as it was the earnest desire of the late Dr. Joule that the utility of the Society might be increased by an adequate extension of its resources in the form of invested funds.

As will be seen from the accounts, the sum of £258 has been invested in a twenty years' loan to the Manchester Corporation, bearing 3 % interest, and terminable on the 25th March, 1914.

It having come to the knowledge of the Librarian, that Dr. Adam Bealey, a native of Lancashire, but now of St. Leonards-on-the-Sea, possessed a miniature bust of his old tutor, Dr. Dalton, Mr. Nicholson entered into communication with Dr. Bealey, with the result that the latter has presented the bust to the Society, with the request that it may be placed in the room in which Dr. Dalton formerly sat with his pupils. Dr. Bealey adds that Mr. Peter Clare, Dr. Dalton's executor, told him that the mould from which the bust, which is of a composition resembling ivory, was cast, was broken after twelve copies were produced. The Council has expressed its thanks to Dr. Bealey for this interesting relic.

The Librarian reports that the following are amongst the works presented to the Society by authors or compilers during the past year, in addition to the publications received from kindred societies and public institutions throughout the world in exchange for the Society's *Memoirs and Proceedings* :—

J. BRENDON CURGENVEN, "Treatment and Disinfection of Scarlet Fever by Antiseptic Injunction." Dr. W. C. WILLIAMSON, F.R.S., &c., "Address on the Mineralization of the Minute Tissues of Animals and Plants." T. GLAZEBRÖÖK RYLANDS, "The Geography of Ptolemy Elucidated." J. BAXENDELL, "Report of Meterological Department, Southport." NEW SOUTH WALES COMMISSION, "An Australian Language." Dr. MICHAEL FOSTER, F.R.S., "A Text-Book of Physiology," 6th Ed., Part I. Prof. FRANK W. VERY, "The Hail Storm of May 20th, 1893." O. A. L. PIHL, "On Occulting Micrometers and their value." Professors A. SCHUSTER and H. B. DIXON, "Studies from the Physical and Chemical Laboratories, Owens College," Vol. I. WM. ANDERSON, "The Interdependence of Abstract Science and Engineering." JAMES E. KEELER, "Visual Observations of Spectrum." H. H. HILDEBRANDSSON and K. L. HAGSTRÖM, "Des Principales Méthodes employées pour Observer et Mesurer Les Nuages." E. H. AMAGAT, "Recherches sur L'Elasticité des Solides"; "Memoires sur L'Elasticité et la Dilatabilité des Fluides." Prof. D. MANCINI, "Shelley's Epipsychidion." MARIANO BÁRCENA, "El Clima de la Ciudad de Mexico." PH. AKERBLOM, "De L'Emploi des Photogrammètres pour Mesurer la Hauteur des Nuages."

The Council reports that the experiment of holding



alternate afternoon and evening meetings during this session has been successful, the attendance at the afternoon meetings having been distinctly in excess of that at the evening meetings, and recommends the continuance of the arrangement.

The Council recommends the continuance of the system of electing Associates of Sections by the usual annual resolution.

ARTHUR MILNES MARSHALL, the second son of Mr. William P. Marshall, C.E., was born in Birmingham, on the 8th June, 1852. He was a lover of nature from his earliest years, and when, after a preliminary education at a private school, he entered St. John's College, Cambridge, he made the several branches of Natural Science his special form of study. Before going to Cambridge he had already graduated as Bachelor of Arts at the University of London in 1870. He began his Cambridge Life in 1871, and in 1874 his name appeared as Senior in the Natural Science Tripos list of that year, and in the following year he took his B.A. degree. After a brief visit to the Zoological Station at Naples, Marshall returned to Cambridge, and assisted his friend, the late Professor Balfour, in the formation and management of new classes in Animal Morphology. He now turned his attention to the completion of his medical studies, and in 1877, the same year that he was elected Fellow of St. John's College, he entered St. Bartholomew's Hospital, London, where he spent the greater part of three years. In 1879 he was appointed Beyer Professor of Zoology in the Owens College, Manchester. From this moment Marshall gave up all idea of a medical career, which was evidently less attractive to him than a life devoted entirely to scientific research, and to the instigation of similar efforts in others. Whilst at Cambridge he had not relinquished his connection with the University of

London, but may be said to have completed his academical course in that University by taking the B.Sc. degree in 1873, and D.Sc. in 1877. Although having no intention of entering upon a medical profession, he nevertheless completed his medical studies by taking the degree of M.B. at Cambridge in 1880, and that of M.D. in 1882. In 1885 he was elected a Fellow of the Royal Society, and served upon the Council for the year 1891. From the time that Marshall was appointed to the Professorship of Zoology in the Owens College he devoted himself unceasingly to what he distinctly understood to be his two-fold and paramount duties, the advancement of the College of which he now formed part, and the pursuit of his investigations in the branch of science he loved. No words can adequately express the magnitude of the loss to either his College, or to Science that his death has occasioned. In the midst of health and hard work Arthur Milnes Marshall was cruelly cut off by a fatal accident upon the rocks around Scawfell, upon the 31st December, 1893. The exact details of the accident are not known. It is a sufficiently mournful fact to have to record that at the comparatively early age of 41, in the prime of his intellectual and physical vigour and work, one of the brightest, most friendly, and sincerest of men, has suddenly passed away from his companions, and the scene of his successful labours. As a teacher he was probably unsurpassed. Possessed of an extremely well-balanced mind, he could see clearly the arguments for and against a question. He was as keenly alive to the errors of a Radical as he was to the mistakes of a Tory. So in biological questions he was never bigoted and was ever cautious. In his most recent and perhaps greatest work, "Vertebrate Embryology," published in the year of his death, nothing is more striking than the extreme moderation and caution of the views expressed upon current biological theories, and the complete absence of any novel idea, however fascinating it might be, unless

supported by evidence as sure as any evidence in biological science can be. To this faculty of open-mindedness and perceptivity of the several sides of a question was due, in a great measure, his success as a teacher. Neither his lectures, nor his text books, were ever overloaded with facts or theories. Facts were given plainly and deliberately, theory was never expressed dogmatically. His personal success may be in no small way attributed to his great capacity for bringing to an issue everything upon which he entered. To leave anything unfinished was a matter of great annoyance to him. Of his capacity for work, it is sufficient to say it seems to have been unlimited. By his death, not only Science and The Owens College have suffered an irreparable loss, but Manchester and the surrounding district have to bear the deprivation of one who had the rare faculty of arousing in others interest in a subject to which they had before been insensitive. This faculty Marshall possessed in a very remarkable degree, and his success is evidenced by the invariably large and attentive audiences he attracted in the many courses of Victoria University Extension Lectures and addresses to the Manchester Microscopical Society, and elsewhere. His lectures on "Natural History" and "Animal Development" were models of what a popular lecture should be; they were sound science; they were never dull. As in his College lectures and his writings, he followed out his often expressed dictum that, unless a thought is capable of being expressed in simple language, it is seldom worthy of expression at all. Professor Marshall was elected President of the Manchester Microscopical Society in 1887, and in this capacity he contributed to the proceedings of the Society several valuable essays upon the biological questions of the day. As President of the Biological Section of the British Association in 1890, he delivered at Leeds a brilliant Address upon the "Theory of

Recapitulation." The more strictly original researches made by Professor Marshall were published as separate papers in various journals, including the publications of this Society, of which he was elected a member December 2, 1879.

The more important of these papers are :—

- "On the early stages of the Development of Nerves in Birds." *Journal of Anatomy*, 1877.
- "The Development of the Cranial Nerves in the Chick." *Quarterly Journal of Microscopical Science*, 1878.
- "The Morphology of the Vertebrate Olfactory Organ." *Quarterly Journal of Microscopical Science*, 1879.
- "On the Head Cavities and Associated Nerves of Elasmobranchs." *Quarterly Journal of Microscopical Science*, 1881.
- "Observations on the Cranial Nerves of Scyllium." Written with Mr. W. B. Spencer. *Quarterly Journal of Microscopical Science*, 1881.
- "The segmental value of the Cranial Nerves." *Journal of Anatomy and Physiology*, 1882.
- "Report on the Pennatulida of Oban bay." Written with Mr. W. P. Marshall. *Midland Naturalist*, 1882.
- "Report on the Pennatulida dredged by H.M.S. 'Triton.'" *Transactions of the Royal Society, Edinburgh*, 1883.
- "On the nervous system of Antidon Rosaceus." *Quarterly Journal of Microscopical Science*, 1884.
- "The Morphology of the Sexual Organs of Hydra." *Proceedings Manchester Literary and Philosophical Society*, Vol. XXIV., 1885.
- "The Development of the Blood Vessels in the Frog." Written with Mr. G. J. Bles. *Owens College Studies*, 1890.
- "The Development of the Kidneys and Fat Bodies in the Frog." Written with Mr. G. J. Bles. *Owens College Studies*, 1890.

In addition to the above, he wrote the three well-known text books :—

“The Frog” (which includes an excellent description of the development as well as the anatomy of the animal), 1882.

“Practical Zoology.” Written with Dr. Hurst. 1886.

“Vertebrate Embryology.” 1893. R. A.

JOHN TYNDALL was born in 1820, at Leighlin Bridge, Carlow, Ireland. In early manhood he came to this country, and was for some time engaged in land surveying. His scientific career may be dated from his appointment in 1847 on the teaching staff of Queenwood College, Hants, where another of our Honorary Members, Dr. Frankland occupied the position of chemist. After a year's stay he proceeded to Germany, to the University of Marburg, Hesse Cassel. Here he studied under Bunsen. Among other physicists whose acquaintance he made were Magnus and Knoblauch, with whom he was associated in some important work on the magnetic condition of matter. During his working career a variety of subjects in experimental philosophy engaged his attention. Among these may be mentioned his researches on the transmission of dark heat rays through media, which absorb all the accompanying light rays ; also the absorption of heat by gases with an important deduction as to the part played by aqueous vapour in the atmosphere in maintaining the earth at a temperature suitable for habitation ; also on the transmission of sound, and on thermal conductivity. He was well known as a mountain climber, and this led to an investigation into the causes of glacier motion. In 1853 he commenced his Friday Evening Lectures at the Royal Institution, London, and afterwards became Professor of Physics there ; this post he retained until 1887. Well-selected experiments, and language appropriate to the kind of work he was undertaking, added

much to his reputation as a lecturer both in this country and America. He was also the author of several works in which the results of modern scientific research were presented in a form likely to be attractive to a wide circle of readers. He died at his residence, Hind Head House, Haslemere, December 4th, 1893. He was elected one of the Honorary Members of the Society April 28th, 1868.

J. B.

HEINRICH HERTZ was born in Hamburg on the 22nd February, 1857. Having passed through the usual school curriculum, he at first chose the life of an engineer as that to which he considered himself best fitted, but, finally, at the age of twenty, decided to devote himself entirely to the pursuit of pure science, and entered Helmholtz's laboratory in the year 1878. The last work of Hertz appeared after his death, accompanied by a preface from the pen of Helmholtz, and that preface contains the most complete account which has yet appeared of Hertz's scientific career. We learn from it how the Berlin professor was struck at once with the great ability of his pupil, and how, when he had to propose the subject of a prize essay a year later, he chose it specially in the hope of interesting Hertz in the work. The question turned on the possibility of electricity possessing inertia. It is well known that the effects of self-induction are similar to those of inertia. If we adopt the older hypothesis of an electric current being due to something moving in the conductor and exerting forces at a distance, there is a very distinct difference between this apparent inertia and that of ordinary matter. The problem consisted in finding an upper limit beyond which no true inertia can exist. Hertz solved the problem, and found that no appreciable part of the self-induction can be due to a true inertia. Led by these experiments to consider the various theories concerning electricity, he turned his attention to the hypothesis of Faraday and Maxwell, which discards action

at a distance and looks to stresses in the medium as the cause of electric and magnetic action. The great work of Hertz consists in the experimental proof which he has given of the fact that electrodynamic action is transmitted through space with a finite velocity. The investigation was one which presented such great difficulties that nobody who did not possess the highest theoretical knowledge, together with a quite exceptionally great experimental ability, could undertake it with any hope of success. In the course of his researches he was led to an important discovery proving an effect of light in facilitating the discharge of electricity from solid surfaces. The paper in which he describes the results of this and other investigations are models of clear writing and lucid explanation. His most important work was done at Carlsruhe, where he occupied the chair of Physics from Easter, 1883, until January, 1889. In October of that year he succeeded Clausius as professor at the University of Bonn. A great part of the last three years of his life was taken up with the preparation of a book on the principles of Mechanics which has recently been published. It is a work which deals with the logical and philosophical aspect of the subject, and which will play an important part in the history of the development of scientific ideas. Hertz died on the 1st of January, 1894. It has been given to few men to accomplish even during a long life as much as Hertz did in the few years allotted to him for scientific work. He was elected an honorary member of the Society in 1889.

A. S.

ARCHIBALD SANDEMAN was born near Perth, and took his degree at Cambridge, where he was bracketed third wrangler, in 1846. For a short time after obtaining his fellowship at Queen's College, he held the office of Mathematical Lecturer in that College. On the opening of Owens College in 1851, he was appointed the first Professor of

Mathematics, and held that post till 1865. His counsel was sought and held in esteem by the Trustees of the College, and the opinions he gave on several matters are reproduced in Mr. Joseph Thompson's book on the College, and indicate well the character of the man. Mr. Sandeman's special study was addressed to the fundamental principles of Elementary Mathematics. In his Principles of Arithmetic, and, more especially, in his Pelicotetics, he elaborates the basis on which arithmetic is founded, and presents an analysis more complete than any other which has been offered. At the same time, the book leaves the impression that Sandeman was a logician rather than a mathematician, and he was so esteemed by Jevons. He also wrote a book on the motion of a particle. Sandeman's habit of thought led him to insist, at the beginning of each branch of the subject he professed, upon a full consideration of the fundamental principles; he demanded for this purpose a much more complete school education than his students possessed, and more severe application than any considerable portion of them desired to give. As a teacher he was not a success, and if the students were discontented with him, he was dissatisfied with them. In 1865 he resigned the professorship, and returned for a short time to Cambridge, when family reasons forced him to assume the charge of the business house at Perth. This became his occupation till his death. Although he lived very much as a recluse, he always retained his interest in the Society, of which, at the time of his death, he had been a member for forty-two years, having been elected in 1851.

R. F. G.

In CHARLES CLAY, who died at his residence, Poulton-le-Fylde, near Blackpool, on September 19, 1893, the Society has lost one of its oldest friends—Dr. Clay's connection with it having extended over the long period of more than fifty-two years—and the medical profession in



Manchester has lost one of its most distinguished members. A touching indication of his affection for the Society was the bequest of his bust, which now occupies an honoured place amongst the similar memorials of famous members in its possession. He was elected a member in 1839, under the presidency of Dalton; his latest communication to its publications, a paper on "The Rapidity of the Growth of Plants," was made in 1889, when he had nearly completed his eighty-eighth year; and at the time of his death he had all but attained the advanced age of ninety-two, his birth having taken place on December 27, 1801, at Bredbury, near Stockport. He has himself recorded in the *Proceedings* of the Society how, about the year 1816, he was "apprenticed" to Mr. Kinder Wood, surgeon, of 51, King Street, Manchester, about the time when the Marsden Street School of Medicine began its operations, the Midwifery Class being conducted jointly by Mr. Wood and Mr. Partington; how at the same time he studied chemistry as a pupil of Dalton's; and how he descended a coal-pit near Oldham, celebrated for serious explosions, in order to procure some fire-damp for Dalton. It is possibly to this early experience that his subsequent interest in geology may be traced; in 1839 he published a volume entitled "Geological Sketches and Observations on Vegetable Fossil Remains, &c., Collected in the Parish of Ashton-under-Lyne, from the Great South Lancashire Coal Field," which included an "Attempt to explain the Original Formation of the Earth on the Theory of Combination." Dr. Clay was at that time practising as a surgeon at Ashton-under-Lyne, having become a licentiate of the Royal College of Surgeons, Edinburgh, in 1823. In 1842 he became extra licentiate of the Royal College of Physicians of London, and in that year removed to Manchester, performed his first operation in ovariectomy, which was successful, and thus obtained the distinction of being the first to introduce the operation

into surgical practice and the acknowledged title of "The Father of Ovariectomy" in this country. He was an original fellow of the Obstetric Society of London, a member of the Gynæcological Society of Boston, U.S., and at one time a Lecturer on Midwifery at St. Mary's Hospital, Manchester, and President of the Medical Society of Manchester. Amongst his many publications are "A Handbook of Obstetric Surgery," and "The Results of Three Hundred and Fourteen Ovarian Operations." His scientific tastes were, however, far from being restricted to the particular branch of his profession in which he achieved such distinction. His latest appearance in person at the Society's house in George Street was in his 88th year, to read a communication bearing on the problem of the squaring of the circle ; and his last communication, already alluded to, which was read in his absence by one of the Secretaries a few months later, testified to his continued interest, as an experimental observer, in botany. As already indicated, he was early a practical geologist. He also took a deep interest in numismatics, was at one time President of the Manchester Numismatical Society, and wrote a "History of the Currency of the Isle of Man."

F. J. F.

THOMAS ARMSTRONG was, at the time of his death, the senior partner of a long-established and well-known Manchester firm of opticians. He was born in 1828. In 1825 his father began the business in the building in Deansgate, formerly the Dean's House, in which it is still carried on. He was associated with various improvements of the microscope, and was a member of most of the popular scientific societies of Manchester, and took a warm though unobtrusive interest in their work ; and he was a Fellow of the Royal Microscopical Society of London. A faithful supporter of the Church of England, he for some time filled the

office of churchwarden in the old church of St. Mary's, Parsonage, before the parish was merged in St. Anne's; and was a constant and liberal friend of all church work. He took a useful part in every public effort for the improvement and social progress of the village—Urmston—and district where he resided. A man of singular modesty, he was quietly but unswervingly loyal to the many organisations with which he was associated. Ever ready to assist in any enterprise for the diffusion of knowledge or the encouragement of healthy recreation, few men of such retiring habits have been so well-known to their neighbours. He died at Llandudno on October 21st, 1893, and the esteem in which he was held was abundantly manifested at the grave-side. He was elected a member of the Society in 1885.

F. J. F.

## MANCHESTER LITERARY AND

Charles Bailey, Treasurer, in Account with the Society,

Statement of the Account

Dr.

|                                                                                                                                                                             | 1893-4. |       | 1892-3.     |                  |
|-----------------------------------------------------------------------------------------------------------------------------------------------------------------------------|---------|-------|-------------|------------------|
|                                                                                                                                                                             | £       | s. d. | £           | s. d.            |
| 1894.—March 31st:—                                                                                                                                                          |         |       |             |                  |
| To Cash in hand, 1st April, 1893 .. .. .                                                                                                                                    |         |       | 136         | 8 4              |
| To Members' Contributions:—                                                                                                                                                 |         |       |             |                  |
| Admission Fees:—1892-93, 2 at £2. 2s. od. .. .. .                                                                                                                           | 4       | 4 0   |             |                  |
| "    1893-94, 6 .. .. .                                                                                                                                                     | 12      | 12 0  |             |                  |
| Subscriptions:— 1889-90, 2 .. .. .                                                                                                                                          | 4       | 4 0   |             |                  |
| "    1890-91, 3 .. .. .                                                                                                                                                     | 6       | 6 0   |             |                  |
| "    1891-92, 6 .. .. .                                                                                                                                                     | 12      | 12 0  |             |                  |
| "    1892-93, 16 .. .. .                                                                                                                                                    | 33      | 12 0  |             |                  |
| "    1893-94, 89 .. .. .                                                                                                                                                    | 186     | 18 0  |             |                  |
| "    1894-95, 1 .. .. .                                                                                                                                                     | 2       | 2 0   |             |                  |
| Half Subscriptions, 1893-94, 3 at £1. 1s. od. .. .. .                                                                                                                       | 3       | 3 0   |             |                  |
| Compounder's Fee, one .. .. .                                                                                                                                               |         |       | 265         | 13 0             |
| To Members' Donations:—                                                                                                                                                     |         |       | 26          | 5 0              |
| For cost of Electric Light Installation:—                                                                                                                                   |         |       |             |                  |
| Mr. Henry Wilde, F.R.S. .. .. .                                                                                                                                             |         |       | 76          | 0 0              |
| For repainting the Society's rooms, repairs, &c. (cost incurred, £89. 5s. 3d.):—                                                                                            |         |       |             |                  |
| Mr. Charles Bailey, F.L.S. .. .. .                                                                                                                                          | 5       | 0 0   |             |                  |
| Mr. John Boyd, F.Z.S. .. .. .                                                                                                                                               | 2       | 0 0   |             |                  |
| Mr. W. G. Groves .. .. .                                                                                                                                                    | 5       | 0 0   |             |                  |
| Mr. J. C. Melvill, M.A., F.L.S. .. .. .                                                                                                                                     | 5       | 0 0   |             |                  |
| Mr. John Ramsbottom, M.Inst. C.E. .. .. .                                                                                                                                   | 5       | 0 0   |             |                  |
| Dr. Edward Schunck, F.R.S., &c. .. .. .                                                                                                                                     | 5       | 0 0   |             |                  |
| Prof. Arthur Schuster, Ph.D., F.R.S., &c. .. .. .                                                                                                                           | 10      | 10 0  |             |                  |
| Mr. Henry Wilde, F.R.S. .. .. .                                                                                                                                             | 24      | 0 0   |             |                  |
| To Balance of Members' Donations towards the cost of oil portrait of the late Mr. Joseph Baxendell, F.R.A.S. .. .                                                           |         |       | 61          | 10 0             |
| To Library Subscriptions:—                                                                                                                                                  |         |       | 0           | 10 6             |
| One Natural History Associate, 1893-94, at 10s. .. .. .                                                                                                                     |         |       | 0           | 10 0             |
| To Contributions from Sections:—                                                                                                                                            |         |       |             |                  |
| Microscopical and Natural History Section, 1893-94 .. .                                                                                                                     | 5       | 5 0   |             | 5 5 0            |
| Physical and Mathematical Section, 1892-93 .. .. .                                                                                                                          | 2       | 2 0   |             | 2 2 0            |
| To Use of the Society's Rooms:—                                                                                                                                             |         |       | 7           | 7 0              |
| Mr. G. Bridgford, 24—25th January, 1894 .. .. .                                                                                                                             | 2       | 2 0   |             | 2 2 0            |
| Manchester Architects' Society to 31st Dec., 1893 .. .. .                                                                                                                   | 37      | 7 0   |             | 30 0 0           |
| Manchester Geological Society to 31st March, 1893.. .. .                                                                                                                    | 0       | 0 0   |             | 30 0 0           |
| Manchester Medical Society to 30th September, 1893 .. .                                                                                                                     | 25      | 0 0   |             | 25 0 0           |
| Manchester Photographic Society to 30th Sept., 1893 .. .                                                                                                                    | 25      | 0 0   |             | 25 5 0           |
| To Sale of the Society's Publications, 1893-94 .. .. .                                                                                                                      |         |       | 89          | 9 0              |
| To Natural History Fund, 1892-93:—                                                                                                                                          |         |       | 11          | 8 10             |
| Dividends on £1225, Great Western Railway Co's Stock .. .                                                                                                                   |         |       | 59          | 10 6             |
| To Joule Memorial Fund:—                                                                                                                                                    |         |       |             |                  |
| Balance of Subscriptions; presented by the subscribers to the fund for the erection of a marble statue in the Manchester Town Hall to the memory of the late Dr. Joule .. . | 257     | 11 0  |             | 0 0 0            |
| To Bank Interest, 1893-94 .. .. .                                                                                                                                           | 1       | 17 6  |             | 1 12 5           |
|                                                                                                                                                                             |         |       | <u>£994</u> | <u>0 8</u>       |
|                                                                                                                                                                             |         |       |             | <u>£642 17 2</u> |
| 1894.—April 1. To Cash in Williams, Deacon, Manchester and Salford Bank Limited .. .. .                                                                                     |         |       | £244        | 13 11            |

PHILOSOPHICAL SOCIETY.

from 1st April, 1893, to 31st March, 1894, with a Comparative for the Session, 1892-93.

Ct.

| 1894—March 31st :—                                                                                                               | 1893-94. |    |    | 1892-93. |    |          |
|----------------------------------------------------------------------------------------------------------------------------------|----------|----|----|----------|----|----------|
|                                                                                                                                  | £        | s. | d. | £        | s. | d.       |
| <b>By Charges on Property :—</b>                                                                                                 |          |    |    |          |    |          |
| Chief Rent (Income Tax deducted) .. .. .                                                                                         | 12       | 11 | 5  | 12       | 12 | 0        |
| Income Tax on Chief Rent .. .. .                                                                                                 | 0        | 7  | 6  | 0        | 6  | 3        |
| Insurance against Fire .. .. .                                                                                                   | 13       | 17 | 6  | 13       | 17 | 6        |
| Repairs to Building, Gas, and Furniture, Ord. Expenditure                                                                        | 3        | 7  | 1  | 14       | 4  | 1        |
| "    "    "    "    Special    "                                                                                                 | 89       | 5  | 3  | 0        | 0  | 0        |
| Electric Light Installation .. .. .                                                                                              | 76       | 0  | 0  | 0        | 0  | 0        |
|                                                                                                                                  |          |    |    | 195      | 8  | 9        |
|                                                                                                                                  |          |    |    |          |    | 40 19 10 |
| <b>By House Expenditure :—</b>                                                                                                   |          |    |    |          |    |          |
| Coal, Gas, Electric Light, Water, Wood, &c. .. .. .                                                                              | 32       | 3  | 2  | 49       | 2  | 3        |
| Tea, Coffee, &c., at Meetings .. .. .                                                                                            | 11       | 12 | 10 | 12       | 5  | 11       |
| Cleaning, Cleaning Carpets, Sweeping Chimneys, &c. ..                                                                            | 6        | 19 | 6  | 4        | 3  | 3        |
|                                                                                                                                  |          |    |    | 50       | 15 | 6        |
|                                                                                                                                  |          |    |    |          |    | 65 11 5  |
| <b>By Administrative Charges :—</b>                                                                                              |          |    |    |          |    |          |
| Clerk and Housekeeper .. .. .                                                                                                    | 62       | 8  | 0  | 67       | 4  | 0        |
| Postages and Carriage of Parcels, and of Memoirs.. ..                                                                            | 24       | 6  | 11 | 40       | 12 | 3        |
| Stationery, Cheques, Receipts, and Engrossing .. .. .                                                                            | 7        | 3  | 4  | 3        | 12 | 1        |
| Printing Circulars, Reports, and List of Members .. ..                                                                           | 0        | 0  | 0  | 16       | 16 | 0        |
|                                                                                                                                  |          |    |    | 93       | 18 | 3        |
|                                                                                                                                  |          |    |    |          |    | 128 4 4  |
| <b>By Publishing :—</b>                                                                                                          |          |    |    |          |    |          |
| Honorarium for editing the Society's publications, 1893-94                                                                       | 50       | 0  | 0  | 50       | 0  | 0        |
| Printing 'Memoirs and Proceedings' .. .. .                                                                                       | 0        | 0  | 0  | 112      | 1  | 0        |
| Binding 'Memoirs and Proceedings' .. .. .                                                                                        | 0        | 0  | 0  | 0        | 0  | 0        |
| Wood Engraving and Lithography .. .. .                                                                                           | 0        | 0  | 0  | 22       | 4  | 0        |
|                                                                                                                                  |          |    |    | 50       | 0  | 0        |
|                                                                                                                                  |          |    |    |          |    | 184 5 0  |
| <b>By Library :—</b>                                                                                                             |          |    |    |          |    |          |
| Binding Books in Library .. .. .                                                                                                 | 0        | 0  | 0  | 5        | 12 | 9        |
| Books and Periodicals .. .. .                                                                                                    | 23       | 13 | 9  | 28       | 2  | 11       |
| Preparing New Catalogue and re-arranging Library .. ..                                                                           | 0        | 0  | 0  | 10       | 0  | 0        |
| Assistant in Library .. .. .                                                                                                     | 8        | 0  | 0  | 8        | 0  | 0        |
| Palæontographical Society for the year 1893 .. .. .                                                                              | 0        | 0  | 0  | 1        | 1  | 0        |
| Ray Society for the year 1893 .. .. .                                                                                            | 0        | 0  | 0  | 1        | 1  | 0        |
| Zoological Record, Vol. 29 for 1892 .. .. .                                                                                      | 1        | 0  | 0  | 1        | 0  | 0        |
|                                                                                                                                  |          |    |    | 32       | 13 | 9        |
|                                                                                                                                  |          |    |    |          |    | 54 17 8  |
| <b>By Natural History Fund :—</b>                                                                                                |          |    |    |          |    |          |
| Natural History Books and Periodicals .. .. .                                                                                    | 18       | 10 | 6  | 19       | 4  | 7        |
| Grant to Microscopical and Natural History Section, for<br>Books and Binding .. .. .                                             | 50       | 0  | 0  | 0        | 0  | 0        |
| Plates for Natural History Papers in 'Memoirs' .. .. .                                                                           | 0        | 0  | 0  | 13       | 6  | 0        |
|                                                                                                                                  |          |    |    | 68       | 10 | 6        |
|                                                                                                                                  |          |    |    |          |    | 32 10 7  |
| <b>By Joule Memorial Fund :—</b>                                                                                                 |          |    |    |          |    |          |
| Loan to the Manchester Corporation, redeemable on the<br>25th March, 1914. Mortgage No. 1564. Public Health<br>Act, 1875 .. .. . | 258      | 0  | 0  | 0        | 0  | 0        |
| <b>By Balance 31st March, 1894..</b> .. .. .                                                                                     | 244      | 13 | 11 |          |    | 136 8 4  |

£994 0 8

£642 17 2

NOTE.—The Accounts (of which the above is a summary) have been audited and found correct by Mr. Harry Grimshaw, F.C.S., and Mr. R. E. Cunliffe, April 13th, 1894.

## Summary Balance Sheet, Session, 1893-94.

| General Account :—                                                                                | £ s. d.        | £ s. d.           |
|---------------------------------------------------------------------------------------------------|----------------|-------------------|
| Balance against this Account, 1st April, 1893 .. .. .                                             |                | 147 18 8          |
| <b>Expenditure during the Session, 1893-94</b>                                                    |                |                   |
| Charges on Property .. .. .                                                                       | 195 8 9        |                   |
| House Expenditure .. .. .                                                                         | 50 15 6        |                   |
| Administrative Charges .. .. .                                                                    | 93 18 3        |                   |
| Publishing .. .. .                                                                                | 50 0 0         |                   |
| Library .. .. .                                                                                   | 32 13 9        |                   |
|                                                                                                   |                | <u>422 16 3</u>   |
|                                                                                                   |                | 570 14 11         |
| <b>Receipts during the Session, 1893-94 :—</b>                                                    |                |                   |
| Subscriptions, Admission Fees, Sections, &c. .. .. .                                              | 273 10 0       |                   |
| Members' Donations towards Special Objects .. .. .                                                | 138 0 6        |                   |
| Use of the Society's rooms .. .. .                                                                | 89 9 0         |                   |
| Sale of the Society's publications .. .. .                                                        | 11 8 10        |                   |
| Bank Interest .. .. .                                                                             | 1 17 6         |                   |
|                                                                                                   |                | <u>514 5 10</u>   |
| Balance against this Account, 31st March, 1894 .. .. .                                            |                | <u>56 9 1</u>     |
| <hr/>                                                                                             |                |                   |
| <b>Compounders' Fund :—</b>                                                                       |                |                   |
| Balance in favour of this Account, 1st April, 1893 .. .. .                                        |                | 177 10 0          |
| Compounder's Fee received during the Session 1893-94 .. .. .                                      |                | <u>26 5 0</u>     |
| Balance in favour of this Account, 31st March, 1894 .. .. .                                       |                | <u>203 15 0</u>   |
| <hr/>                                                                                             |                |                   |
| <b>Natural History Fund :—</b>                                                                    |                |                   |
| Balance in favour of this Account, 1st April, 1893 .. .. .                                        | 106 17 0       |                   |
| Dividends on Great Western Railway Co.'s Stock, £1,225, during the Session, 1893-94 .. .. .       | <u>59 10 6</u> |                   |
|                                                                                                   |                | 166 7 6           |
| <b>Expenditure during the Session, 1893-94 :—</b>                                                 |                |                   |
| Natural History Books and Periodicals .. .. .                                                     | 18 10 6        |                   |
| Grant to Natural History and Microscopical Section for Books and Binding .. .. .                  | <u>50 0 0</u>  |                   |
|                                                                                                   |                | 68 10 6           |
| Balance in favour of this Account, 31st March, 1894 .. .. .                                       |                | <u>97 17 0</u>    |
| <hr/>                                                                                             |                |                   |
| <b>Joule Memorial Fund :—</b>                                                                     |                |                   |
| Investment in Loan to the Manchester Corporation, redeemable 25th March, 1914. (No. 1564) .. .. . |                | 258 0 0           |
| Balance of public subscriptions received from the Joule Memorial Fund Committee .. .. .           |                | <u>257 11 0</u>   |
| Balance against this Account, 31st March, 1894 .. .. .                                            |                | <u>0 9 0</u>      |
| <hr/>                                                                                             |                |                   |
| <b>Credit Balances :—</b>                                                                         |                |                   |
| Compounders' Fund, as above .. .. .                                                               | 203 15 0       |                   |
| Natural History Fund, as above .. .. .                                                            | <u>97 17 0</u> |                   |
|                                                                                                   |                | 301 12 0          |
| <b>Debit Balances :—</b>                                                                          |                |                   |
| General Account, as above .. .. .                                                                 | 56 9 1         |                   |
| Joule Memorial Fund, as above .. .. .                                                             | <u>0 9 0</u>   |                   |
|                                                                                                   |                | 56 18 1           |
| Cash in Williams, Deacon, and Manchester and Salford Bank, Limited, 31st March, 1894 .. .. .      |                | <u>£244 13 11</u> |

## **Annual Report of the Council of the Microscopical and Natural History Section.**

The Session 1893-4 has not differed from those immediately preceding; the same number of meetings have been held, and the attendance has been about the average.

The most interesting communication was that of Mr. HERBERT C. CHADWICK, F.R.M.S.: "A Study of the Siphonophora," which was illustrated by both the lantern and the microscope.

Interesting communications were also made by Messrs. ALLEN, BAILEY, BROADBENT, CAMERON, HYDE, MELVILL, OLDHAM, and ROGERS.

The following books have been purchased:—

1. Index Kewensis, HOOKER.
2. Fauna and Flora des Golfes von Neapel, Dr. J. W. SPENGLER.

Mr. THOMAS ROGERS presented the following book to the Section:—

A Synonymic Catalogue of Marine Bryozoa.

The Library Sub-Committee report that the first portion of the new catalogue has been printed, and that the manuscript of the second portion is nearly completed.

One new member, Professor F. E. WEISS, and four new associates, Messrs. T. A. COWARD, CH. OLDHAM, J. F. ALLEN, and J. WATSON have been elected.

Mr. E. HALKYARD has resigned, owing to his residing abroad during the winter, and Dr. TATHAM, in consequence of his removal to London.

The Section has also lost Mr. WM. KING DEANE and Professor A. MILNES MARSHALL through death.

A list of members and associates is appended.

*Members* :—J. J. ASHWORTH, CH. BAILEY, F.L.S., J. BOYD, G. H. BROADBENT, M.R.C.S., H. BROGDEN, A. BROWN, M.D., S. COTTAM, F.R.A.S., ED. COWARD, M.I.C.E., R. E. CUNLIFFE, R. D. DARBISHIRE, B.A., F.G.S., H. C. DENT, F.L.S., F. J. FARADAY, F.L.S., A. HODGKINSON, B.Sc., M.B., C. J. HEYWOOD, J. COSMO MELVILL, F.L.S., M.A., F. NICHOLSON, F.Z.S., C. H. SCHILL, F. E. WEISS, B.Sc.

*Associates* :—J. F. ALLEN, WM. BLACKBURN, E. BLES, P. CAMERON, F.E.S., H. C. CHADWICK, T. A. COWARD, P. CUNLIFFE, H. HYDE, LESLIE JONES, M.D., CH. OLDHAM, TH. ROGERS, W. R. SCOWCROFT, T. SINGTON, G. NASH SKIPP, MARK STIRRUP, F.G.S., J. WATSON, R. WHEELER.

---



*Microscopical and Natural History Section Accounts. 225*

*The Microscopical and Natural History Section of the Manchester Literary and Philosophical Society in account with the Parent Society for Grant for Books from Natural History Fund,*

| <b>Dr.</b>                                                         |                | <b>Cr.</b>                                                  |                |
|--------------------------------------------------------------------|----------------|-------------------------------------------------------------|----------------|
| 1893.                                                              | £ s. d.        | 1893.                                                       | £ s. d.        |
| Dec. 21. To Grant by Parent Society(per Treasurer, C. Bailey)..... | 50 0 0         | By Balance due to Section from Natural History Fund ...     | 8 12 11        |
|                                                                    |                | May 4. ,, "Kent's Barrier Reef" .....                       | 3 13 6         |
|                                                                    |                | 12. ,, "Thesaurus Entomologicus" .....                      | 7 11 9         |
|                                                                    |                | Oct. 13. ,, Cataloguing Nat. History Books, G. Walker ..... | 2 2 0          |
|                                                                    |                | Nov. 16. ,, Index Kewensis, Part 1 ...                      | 2 2 0          |
|                                                                    |                | Dec. 14. ,, Do. do. Part 2 ...                              | 2 2 0          |
|                                                                    |                | 1894.                                                       |                |
|                                                                    |                | Mar. 30. ,, "Study of Mammals," Flower.....                 | 0 18 9         |
|                                                                    |                | ,, Balance .....                                            | 22 17 1        |
|                                                                    | <u>£50 0 0</u> |                                                             | <u>£50 0 0</u> |
| To Balance of Grant unexpended .....                               | £22 17 1       |                                                             |                |

*Mark Stirrup, Treasurer, in account with the Microscopical and Natural History Section of the Manchester Literary and Philosophical Society.*

| <b>Dr.</b>                        |                  | <b>Cr.</b>                                                                   |                  |
|-----------------------------------|------------------|------------------------------------------------------------------------------|------------------|
| 1893.                             | £ s. d.          | 1893.                                                                        | £ s. d.          |
| April 10. To Balance in Bank..... | 69 8 5           | May 3. By B. O'Connor, Printing Circulars .....                              | 0 11 0           |
| Dec. 20. ,, Bank Interest .....   | 0 15 9           | 4. ,, T. Sowler & Co., Printing (1889) .....                                 | 0 9 6            |
|                                   |                  | ,, ,, W. H. Allen & Co., "Kent's Barrier Reef" .....                         | 3 13 6           |
|                                   |                  | 12. ,, F. L. Dames, "Thesaurus Entomologicus" .....                          | 7 11 9           |
|                                   |                  | Oct. 15. ,, G. Walker, Cataloguing Nat. History Books .....                  | 2 2 0            |
|                                   |                  | 17. ,, J. E. Cornish, "Naturalist," Jan. to Sept. ....                       | 0 4 6            |
|                                   |                  | Nov. 6. ,, West, Newman & Co., "Journal of Botany," 1893                     | 0 12 0           |
|                                   |                  | 16. ,, Henry Frowde, "Index Kewensis," Part I. ....                          | 2 2 0            |
|                                   |                  | Dec. 14. ,, Do. Part 2. ....                                                 | 2 2 0            |
|                                   |                  | 1894.                                                                        |                  |
|                                   |                  | Jan. 10. ,, D. Douglas, "Annals of Scot. Nat. History," 1894                 | 0 7 6            |
|                                   |                  | Mar. 28. ,, Parent Society, Sectional Subscription .....                     | 5 5 0            |
|                                   |                  | 30. ,, J. E. Cornish, "Flower's Study of Mammals" .....                      | 0 18 9           |
|                                   |                  | ,, ,, Do. Carriage of Parcel.....                                            | 0 0 6            |
|                                   |                  | ,, ,, Gurney & Jackson, "Ibis," for 1892-3-4.....                            | 3 3 0            |
|                                   |                  | April 2. ,, Do. Surcharge on above, 1892 and '93 .....                       | 0 6 0            |
|                                   |                  | 3. ,, Chas. Hargreaves, Teas, £2. 16s. cd.; Postages, &c., £1. 3s. 11d. .... | 3 19 11          |
|                                   |                  | ,, ,, B. O'Connor, Printing Cards and Circulars .....                        | 2 19 0           |
|                                   |                  | ,, ,, Mark Stirrup, Postages and P. Order .....                              | 0 1 0            |
|                                   |                  | ,, Balance in Manchester and Salford Bank (St. Ann's)....                    | 101 5 3          |
|                                   | <u>£137 14 2</u> |                                                                              | <u>£137 14 2</u> |

Examined and found correct, 9th April, 1894.  
(Signed) W. R. SCOWCROFT,  
J. FENWICK ALLEN.

To Balance to Credit of Section..... £101 5 3

## THE COUNCIL AND MEMBERS.

---

APRIL 17, 1894.

---

*President.*

HENRY WILDE, F.R.S.

*Vice-Presidents.*

ARTHUR SCHUSTER, PH.D., F.R.S., F.R.A.S.

EDWARD SCHUNCK, PH.D. F.R.S., F.C.S.

OSBORNE REYNOLDS, M.A., LL.D., F.R.S.

J. C. MELVILL, M.A., F.L.S.

*Secretaries.*

FREDERICK JAMES FARADAY, F.L.S.

REGINALD F. GWYTHYR, M.A.

*Treasurer.*

CHARLES BAILEY, F.L.S.

*Librarian.*

FRANCIS NICHOLSON, F.Z.S.

*Of the Council.*

HAROLD B. DIXON, M.A., F.R.S.

ALEXANDER HODGKINSON, M.B., B.Sc.

JOSEPH THOMPSON.

FRANCIS JONES, F.C.S.

W. E. HOYLE, M.A.

JAMES BOTTOMLEY, B.A., D.Sc., F.C.S.

## HONORARY MEMBERS.

*Date of Election.*

- 1892, April 26. Abney, Capt. W. de W., R.E., F.R.S. *S. Kensington.*
- 1892, April 26. Amagat, E. F. 34, *Rue St. Lambert, Paris.*
- 1894, April 17. Appell, Paul, Membre de l'Institut, Professor at the Faculty of Sciences. *Paris.*
- 1887, April 19. Armstrong, Wm. George, Lord, C.B., D.C.L., LL.D. F.R.S. *Newcastle-on-Tyne.*
- 1892, April 26. Ascherson, Paul F. Aug., Professor. *Berlin.*
- 1892, April 26. Baeyer, Adolf von, Professor of Chemistry. For. Mem. R.S. 1, *Arcisstrasse, Munich.*
- 1886, Feb. 9. Baker, Sir Benjamin, LL.D., M. Inst. C.E., F.R.S. 2, *Queen's Square Place, Westminster, S.W.*
- 1886, Feb. 9. Baker, John Gilbert, F.R.S. *Kew.*
- 1886, Feb. 9. Berthelot, Prof. Marcellin, For. Mem. R.S., Membre de l'Institut. *Paris.*
- 1892, April 26. Boltzmann, Ludwig, Professor of Physics. *Munich.*
- 1892, April 26. Brioschi, Francesco. Pres. R. Accad. dei Lincei. 4, *Place Cavour, Milan.*
- 1886, Feb. 9. Buchan, Alexander, F.R.S.E. 72, *Northumberland Street, Edinburgh.*
- 1860, April 17. Bunsen, Robert Wilhelm, Ph.D., For. Mem. R.S., *Heidelberg.*
- 1888, April 17. Cannizzaro, S., For. Mem. R.S., Prof. of Chemistry. *University of Rome.*
- 1889, April 30. Carruthers, William, Pres. L.S., F.R.S. Keeper of Botanical Dept., British Museum.
- 1859, Jan. 25. Cayley, Arthur, M.A., LL.D., D.C.L., V.P.R.A.S., F.R.S., Sadlerian Prof. of Pure Maths. in the Univ. of Cambridge, Cor. Mem. Inst. Fr. (Acad. Sci.), &c. *Garden House, Cambridge.*
- 1886, Oct. 30. Clifton, Robert Bellamy, M.A., F.R.S., F.R.A.S., Prof. of Natural Philosophy, Oxford. *New Museum, Oxford.*
- 1889, April 30. Cohn, Ferdinand, Professor of Botany. 26, *Schweidnitzer Stadtgraben, Breslau.*
- 1887, April 19. Cornu, Professor Alfred, For. Mem. R.S., Membre de l'Institut. *École Polytechnique, Paris.*
- 1892, April 26. Curtius, Theodor, Professor of Chemistry. *Kiel.*
- 1892, April 26. Darboux, Gaston, Membre de l'Institut, Professor at the Faculty of Sciences. 36, *Rue Gay Lussac, Paris.*

*Honorary Members.**Date of Election.*

- 1886, Feb. 9. Dawson, Sir John William, C.M.G., M.A., LL.D., F.R.S.,  
F.G.S. *McGill College, Montreal.*
- 1894, April 17. Debus, H., Ph.D., F.R.S. 1, *Obere Sophienstrasse, Cassel,  
Hessen, Germany.*
- 1888, April 17. Dewalque, Gustave, Professor of Geology. *University of  
Liège.*
- 1892, April 26. Dohrn, Dr. Anton, Zoological Station. *Naples.*
- 1892, April 26. Du Bois-Reymond, Emil, Professor of Physiology. For.  
Mem. R.S. 15, *Neue Wilhelm Strasse, Berlin.*
- 1892, April 26. Dyer, W. T. Thiselton, C.B., F.R.S., Director, Botanical  
Gardens. *Kew.*
- 1892, April 26. Edison, Thomas Alva. *Orange, N. J., U.S.A.*
- 1886, April 30. Farlow, W. G., Professor of Botany. *Harvard College,  
Cambridge, Mass., U.S.A.*
- 1889, April 30. Flower, Sir William Henry, C.B., LL.D., F.R.S. Director  
of Nat. Hist. Dept. British Museum.
- 1889, April 30. Foster, Michael, M.A., M.D., LL.D., Sec. R.S., Professor  
of Physiology. *Trinity College, Cambridge.*
- 1860, Mar. 9. Frankland, Edward, Ph.D., M.D., LL.D., D.C.L.,  
V.P.C.S., F.R.S., Cor. Mem. Inst. Fr. (Acad. Sci.),  
&c. *The Yews, Reigate Hill, Reigate.*
- 1892, April 26. Friedel, Ch., D.C.L., Membre de l'Institut, Professor at the  
Faculty of Sciences. 9, *Rue Michelet, Paris.*
- 1892, April 26. Fürbringer, Max, Professor of Botany. *Jena.*
- 1892, April 26. Gegenbaur, Carl, For. Mem. R.S., Professor of Anatomy,  
*Heidelberg.*
- 1892, April 26. Gibbs, Professor W. J. *West Nyack, N. Y., U.S.A.*
- 1894, April 17. Glaisher, J. W. L., D.Sc., F.R.S. *Trinity College,  
Cambridge.*
- 1894, April 17. Gouy, A., Professor at the Faculty of Sciences. *Lyons.*
- 1894, April 17. Guldberg, Professor C. M. *Christiania, Norway.*
- 1894, April 17. Harcourt, A. G. Vernon, F.R.S. *Cowley Grange, Oxford.*
- 1894, April 17. Heaviside, Oliver, F.R.S. *Paignton, Devon.*
- 1892, April 26. Hermite, Ch., For. Mem. R.S., Membre de l'Institut.  
2, *Rue de la Sorbonne, Paris.*
- 1892, April 26. Hill, W. G. *Washington.*
- 1848, Jan. 25. Hind, John Russell, LL.D., F.R.S., F.R.A.S., Cor. Mem.  
Inst. Fr. (Acad. Sci.) 3, *Cambridge Park Gardens,  
Twickenham.*
- 1881, April 17. Hittorf, Johann Wilhelm, Professor of Physics. *Polytech-  
nicum, Münster.*
- 1892, April 26. Hoff, J. Van't, Professor of Chemistry. *Amsterdam.*
- 1892, April 26. Hooker, Sir Joseph D., F.R.S. *Sunningdale.*

*Honorary Members.*

229

*Date of Election.*

- 1869, Jan. 12. Huggins, William, LL.D., D.C.L., F.R.S., F.R.A.S.,  
Cor. Mem. Inst. Fr. (Acad. Sci.) 90, *Upper Tulse Hill,  
Brixton, London, S.W.*
- 1872, April 30. Huxley, Thomas Henry, M.D., Ph.D., LL.D., D.C.L.,  
P.P.R.S., Hon. Prof. of Biology in Royal School of  
Mines. Cor. Mem. Inst. Fr. (Acad. Sci.), &c. *Hodeslea,  
Staveley Road, Eastbourne.*
- 1851, April 22. Kelvin, William Thomson, Lord, M.A., D.C.L., LL.D.,  
Pres. R.S., F.R.S.E., Prof. of Nat. Phil. in Univ. of  
Glasgow. For. Assoc. Inst. Fr. (Acad. Sci.), 2, *College,  
Glasgow.*
- 1852, Oct. 16. Kirkman, Rev. Thomas Penyngton, M.A., F.R.S. *Fern-  
royd, Bowdon.*
- 1892, April 26. Klein, Felix, Professor of Mathematics, For. Mem. R.S.,  
3, *Wilhelm Weber Strasse, Göttingen.*
- 1894, April 17. Könisberger, L., Professor of Mathematics. *Heidelberg.*
- 1892, April 26. Ladenburg, A., Professor of Chemistry. 3, *Kaiser Wilhelm  
Strasse, Breslau.*
- 1887, April 19. Langley, Prof. S. P. *Smithsonian Institution, Washing-  
ton, U.S.A.*
- 1894, April 17. Lie, M. Sophus, Professor of Mathematics. *Leipzig.*
- 1892, April 26. Liebermann, C., Professor of Chemistry. 29, *Matthäi-  
Kirch Strasse, Berlin.*
- 1887, April 19. Lockyer, Norman, C.B., F.R.S., Corr. Mem. Inst. Fr. (Acad.  
Sci.) *Science School, Kensington.*
- 1889, April 30. Lubbock, Sir John, Bart., M.P., D.C.L., LL.D., F.R.S.  
15, *Lombard Street, E.C.*
- 1892, April 26. Ludwig, Carl, For. Mem. R.S., Professor of Physiology.  
16, *Liebig Strasse, Leipzig.*
- 1892, April 26. Marshall, Alfred, Professor of Political Economy. *Balliol  
Croft, Madingley Road, Cambridge.*
- 1892, April 26. Mascart, E., For. Mem. R.S., Membre de l'Institut, Profes-  
sor at the Collège de France. 176, *Rue de l'Université,  
Paris.*
- 1889, April 30. Mendeléeff, D., For. Mem. R.S. *St. Petersburg.*
- 1889, April 30. von Meyer, Lothar, Professor of Chemistry. *Tübingen.*
- 1892, April 26. Meyer, Victor, Professor of Chemistry. 55, *Plöck Strasse,  
Heidelberg.*
- 1892, April 26. Moissan, H., Membre de l'Institut, Professor at the École  
Supérieure de Pharmacie. 7, *Rue Vauquelin, Paris.*
- 1894, April 17. Murray, John, D.Sc. *Challenger Office, 45, Frederick  
Street, Edinburgh.*
- 1894, April 17. Neumayer, Professor G., Director of the See Warte,  
*Hamburg.*

*Date of Election.*

- 1887, April 19. Newcomb, Prof. Simon, For. Mem. R.S. *Johns Hopkins University, Baltimore, U.S.A.*
- 1894, April 17. Ostwald, W., Professor of Chemistry. 34, *Brüderstrasse, Leipzig.*
- 1866, Feb. 9. Pasteur, Louis, For. Mem. R.S., Membre de l'Institut, *Paris.*
- 1892, April 26. Perkin, W. H., F.R.S. *The Chestnuts, Sudbury, Harrow.*
- 1894, April 17. Pfeffer, W., Professor of Botany. *Botanisches Institut, Leipzig.*
- 1851, April 29. Playfair, Lyon, Lord, K.C.B., LL.D., Ph.D., F.R.S., F.G.S., V.P.C.S., &c. 68, *Onslow Gardens, London, S.W.*
- 1892, April 26. Poincaré H., Membre de l'Institut, Professor at the Faculty of Sciences. 63, *Rue Claude Bernard, Paris.*
- 1866, Jan. 23. Prestwich, Joseph, F.R.S., F.G.S., Corr. Mem. Inst. Fr. (Acad. Sci.) *Shoreham, near Sevenoaks.*
- 1892, April 26. Quincke, G. H., Professor of Physics. For. Mem. R.S. 60, *Haupt Strasse, Heidelberg.*
- 1886, Jan. 23. Ramsay, Sir Andrew Crombie, LL.D., F.R.S., F.G.S. 15, *Cromwell Crescent, South Kensington, London.*
- 1892, April 26. Raoult, F., Dean of the Faculty of Sciences. 2, *Rue des Alpes, Grenoble.*
- 1849, Jan. 23. Rawson, Robert, F.R.A.S. *Havant, Hants.*
- 1866, Feb. 9. Rayleigh, John William Strutt, Lord, M.A., D.C.L., (Oxon), LL.D. (Univ. McGill), Sec. R.S., F.R.A.S. *Tirling Place, Witham, Essex.*
- 1889, April 30. Résal, Professor Henri, Membre de l'Institut. *École Polytechnique, Paris.*
- 1889, April 30. Roscher, Dr. Wilhelm, K. Geheimer Rath, and Professor of Political Economy. *Leipsic.*
- 1889, April 30. Routh, Edward John, Sc. D., F.R.S. *Newnham Cottage, Cambridge.*
- 1894, April 17. Rowland, Prof. H. A., For. Mem. R.S. *John Hopkins University, Baltimore, U.S.A.*
- 1872, April 30. Sachs, Julius von, Ph.D., For. Mem. R.S., *Wurzburg.*
- 1889, April 30. Salmon, Rev. George, D.D., D.C.L., LL.D., F.R.S., Regius Professor of Divinity. *Provost's House, Trinity College, Dublin.*
- 1892, April 26. Salvin, Osbert, F.R.S. *Haslemere.*
- 1892, April 26. Saporta, the Marquis de. *Aix-en-Provence, Bouches du Rhône.*
- 1894, April 17. Sanderson, Prof. J. S. Burdon, F.R.S. *Oxford.*
- 1892, April 26. Sharpe, R. Bowdler. *British Museum, Cromwell Road, S.W.*
- 1892, April 26. Solms, H. Graf zu, Professor of Botany. *Strasburg.*

## Honorary Members.

231

- Date of Election.*
- 1869, Dec. 14. Sorby, Henry Clifton, LL.D., F.R.S., F.G.S., &c. *Broomfield, Sheffield.*
- 1851, April 29. Stokes, Sir George Gabriel, Bart., M.A., M.P., LL.D., D.C.L., F.R.S., Lucasian Professor of Mathem. Univ. Cambridge, F.C.P.S., Cor. Mem. Inst. Fr. (Acad. Sci.), &c. *Lensfield Cottage, Cambridge.*
- 1894, April 17. Stone, Professor E. J., F.R.S. *Radcliffe Observatory, Oxford.*
- 1886, Feb. 9. Strasburger, Professor. *Bonn.*
- 1861, Jan. 22. Sylvester, James Joseph, M.A., D.C.L., LL.D., F.R.S., Savilian Prof. of Geom. in the Univ. of Oxford, Cor. Mem. Inst. Fr. (Acad. Sci.), &c. *New College, Oxford.*
- 1868, April 28. Tait, Peter Guthrie, M.A., F.R.S.E., &c., Professor of Natural Philosophy, Edinburgh. 38, *George Square, Edinburgh.*
- 1894, April 17. Thorpe, T. E., Ph.D., F.R.S. *Laboratory, Somerset House, London, W.C.*
- 1872, April 30. Trécul, A., Membre de l'Institut. *Paris.*
- 1894, April 17. Turner, Prof. Sir Wm., F.R.S. *Edinburgh.*
- 1886, Feb. 9. Tylor, Edward Burnett, F.R.S., D.C.L. (Oxon), LL.D. (St. And. and McGill Colls.), Keeper of University Museum. *Oxford.*
- 1894, April 17. Vines, Sidney, Professor of Botany, F.R.S. *Headington Hill, Oxford.*
- 1894, April 17. Waage, Professor P. *Christiania, Norway.*
- 1892, April 26. Walker, General Francis A., Professor of Political Economy. 237, *Beacon Street, Boston, U.S.A.*
- 1894, April 17. Warburg, Professor E. 8, *Goethestrasse, Freiburg, Baden.*
- 1894, April 17. Ward, Professor H. M., F.R.S. *Cooper's Hill, Englefield Green, Surrey.*
- 1894, April 17. Weismann, Professor August. *Freiburg, Baden.*
- 1892, April 26. Wiedemann G., Prof. of Physics, For. Mem. R.S. 35, *Thalstrasse, Leipsic.*
- 1889, April 30. Williamson, Alexander William, Ph.D., LL.D., F.R.S., Cor. Mem. Inst. Fr. (Acad. Sci.). *High Pitfold, Shotton-mill, Haslemere.*
- 1886, Feb. 7. Williamson, W. C., LL.D., F.R.S. 43, *Elms Road, Clapham Common, London.*
- 1886, Feb. 9. Young, Prof. C. A. *Princeton College, N. J., U. S. A.*
- 1888, April 17. Zirkel, Ferdinand, Professor of Mineralogy. *University of Leipsic.*
-

*Corresponding Members.**Date of Election.*

1870. March 8. Cockle, The Hon. Sir James, M.A., F.R.S., F.R.A.S.,  
F.C.P.S. 12, *St. Stephen's Road, Bayswater, London.*
- 1866, Jan. 23. De Caligny, Anatole, Marquis, Corres. Mem. Acadd. Sc.  
Turin and Caen. Socc. Agr. Lyons, Sci. Cherbourg,  
Liège, &c.
- 1861, April 2. Durand-Fardel, Max, M.D., Chev. of the Legion of  
Honour, &c. 36, *Rue de Lille, Paris.*
- 1849, April 17. Girardin, J., Off. Legion of Honour, Corr. Mem. Instit.  
France, &c. *Lille.*
- 1850, April 30. Harley, Rev. Robert, M.A., F.R.S. *Savile Park, Halifax,  
Yorks.*
- 1882, Nov. 14. Herford, Rev. Brooke, 91, Fitzjohn's Avenue, Hampstead,  
London, N.W.
- 1859, Jan. 25. Le Jolis, Auguste-François, Ph.D. Archiviste perpétuel  
and late President of the Soc. Nat. Sc., Cherbourg, &c.  
*Cherbourg.*
- 1857, Jan. 27. Lowe, Edward Joseph, F.R.S., F.R.A.S., F.G.S., Mem.  
Brit. Met. Soc., &c. *Shirenewton Hall, near Chepstow.*
-



Ordinary Members.

*Date of Election.*

- 1870, Dec. 13. Angell, John, F.C.S., F.I.C. 6, *Beaconsfield, Derby Road, Fallowfield, Manchester.*
- 1861, Jan. 22. Anson, Rev. George Henry Greville, M.A. *Birch Rectory, Rusholme.*
- 1837, Aug. 11. Ashton, Thomas. 36, *Charlotte Street.*
- 1881, Nov. 1. Ashton, Thomas Gair, M.A. 36, *Charlotte Street.*
- 1887, Nov. 16. Ashworth, J. Jackson. 39, *Spring Gardens, City.*
- 1865, Nov. 15. Bailey, Charles, F.L.S. *Ashfield, College Road, Whalley Range, Manchester.*
- 1888, Nov. 13. Bailey, G. H., D.Sc., Ph.D. *Owens College.*
- 1888, Feb. 7. Bailey, Alderman Sir W. H. *Sale Hall, Sale.*
- 1894, Jan. 9. Beckett, J. Hampden, B.Sc. *Corbar Hill House, Buxton.*
- 1868, Dec. 15. Bickham, Spencer H. *Underdown, Ledbury.*
- 1861, Jan. 22. Bottomley, James, D.Sc., B.A., F.C.S. 220, *Lower Broughton Road.*
- 1875, Nov. 16. Boyd, John. *Barton House, Didsbury Park, Didsbury.*
- 1889, Oct. 15. Bradley, Nathaniel. *Sunnyside, Whalley Range.*
- 1894, Mar. 6. Broadbent, G. H., M.R.C.S. 8, *Ardwick Green.*
- 1855, April 17. Brockbank, William, F.G.S., F.L.S. *Chapel Walks.*
- 1861, April 2. Brogden, Henry, F.G.S. *Hale Lodge, Altrincham.*
- 1844, Jan. 22. Brooks, Sir William Cunliffe, Bart., M.A., M.P. *Bank, 92, King Street.*
- 1889, April 16. Brooks, Herbert S. *Slade House, Levenshulme.*
- 1860, Jan. 23. Brothers, Alfred, F.R.A.S. 14, *St. Ann's Square, Manchester.*
- 1886, April 6. Brown, Alfred, M.A., M.D. *Claremont, Higher Broughton.*
- 1846, Jan. 27. Browne, Henry, M.A. (Glas.), M.R.C.S. (Lond.), M.D. (Lond.). *The Gables, Victoria Park.*
- 1889, Jan. 8. Brownell, T. W. 68, *Robert Street, Upper Brook Street.*
- 1880, Oct. 15. Budenberg, C. F., M.Sc. *Bowdon Lane, Marple, Cheshire.*
- 1872, Nov. 12. Burghardt, Charles Anthony, Ph.D. 35, *Fountain Street.*
- 1893, April 18. Brown, F. E., B.A. *Hulme Grammar School, Manchester.*
- 1854, April 18. Christie, Richard Copley, M.A. *Ribsdon, Bagshot, Surrey.*
- 1884, Nov. 4. Corbett, Joseph. *Town Hall, Salford.*
- 1853, Jan. 25. Cottam, Samuel, F.R.A.S., F.R. Hist. S., F.C.A. 49, *Spring Gardens.*
- 1893, Jan. 10. Chadwick, W. I. 2, *St. Mary's Street, City.*
- 1859, Jan. 25. Coward, Edward. *Heaton Mersey, near Manchester.*
- 1876, April 18. Cunliffe, Robert Ellis. *Halton Bank, Pendleton.*

*Date of Election.*

- 1871, Nov. 8. Dale, Richard Samuel, B.A. 1, *Chester Terrace, Chester Road.*
- 1853, April 19. Darbishire, Robert Dukinfield, B.A., F.S.A. *St. James' Square.*
- 1894, Mar. 6. Delépine, Sheridan, M.D., Professor of Pathology. *Owens College.*
- 1879, Mar. 18. Dent, Hastings Charles, F.L.S., F.R.G.S. 20, *Thurloe Square, London, S.W.*
- 1878, Feb. 8. Dixon, Harold B., M.A., F.R.S., Professor of Chemistry. *Owens College.*
- 1883, Oct. 2. Faraday, Frederick James, F.L.S., F.S.S. *Ramsay Lodge, Slade Lane, Levenshulme.*
- 1886, Feb. 9. Gee, W. W. Haldane, B.Sc. *Technical School, Princess Street, Manchester.*
- 1881, Nov. 1. Greg, Arthur. *Eagley, near Bolton.*
- 1874, Nov. 3. Grimshaw, Harry, F.G.S. *Thornton View, Clayton.*
- 1888, Feb. 7. Grimshaw, William. *Stoneleigh, Sale, and 75, Princess Street, City.*
- 1892, Nov. 15. Groves, W. G. *The Larches, Alderley Edge.*
- 1875, Feb. 9. Gwyther, R. F., M.A., Fielden Lecturer in Mathematics. *Owens College.*
- 1890, Feb. 18. Harker, Thomas. *Brook House, Fallowfield.*
- 1862, Nov. 4. Hart, Peter. *Messrs. Tennants & Co., Mill Street, Clayton N. Manchester.*
- 1873, Dec. 16. Heelis, James. 71, *Princess Street.*
- 1890, Mar. 4. Henderson, H. A. *Eastbourne House, Chorlton Road.*
- 1890, Nov. 4. Heenan, R. H., M.I.C.E., M.I.M.E. *Manor House, Wilmslow Park, Wilmslow.*
- 1889, Jan. 8. Heywood, Charles J. *Chaseley, Pendleton.*
- 1833, April 26. Heywood, James, F.R.S., F.G.S., F.S.A. 26, *Kensington Palace Gardens, London, W.*
- 1884, Jan. 8. Hodgkinson, Alexander, M.B., B.Sc. 18, *St. John Street.*
- 1889, Oct. 15. Hoyle, W. E., M.A., Keeper of the Manchester Museum. *Owens College.*
- 1870, Nov. 1. Johnson, William H., B.Sc. 26, *Lever Street.*
- 1878, Nov. 26. Jones, Francis, F.R.S.E., F.C.S. *Grammar School.*
- 1890, Jan. 7. Joseland, H. L., B.A. *The Grammar School.*
- 1891, Nov. 17. Joyce, Samuel, Electrical Engineer. *Technical School, Princess Street, City.*
- 1886, Jan. 12. Kay, Thomas, J.P. *Moorfield, Stockport.*
- 1852, Jan. 27. Kennedy, John Lawson. 47, *Mosley Street.*
- 1891, Dec. 1. King, John Edward, M.A., High Master. *Manchester Grammar School.*

*Date of Election.*

- 1893, Nov. 14. Lamb, H., Professor of Mathematics, M.A., F.R.S., &c. *Medindee, Burton Road, Didsbury.*
- 1890, Nov. 4. Langdon, Maurice Julius, Ph.D. 3, *Cooper Street.*
- 1884, April 15. Leech, Daniel John, Professor of Materia Medica, M.D. *Owens College.*
- 1857, Jan. 27. Longridge, Robert Bewick. *Yew Tree House, Tabley, Knutsford.*
- 1870, April 19. Lowe, Charles, F.C.S. *Summerfield House, Reddish, Stockport.*
- 1866, Nov. 13. McDougall, Arthur, B.Sc. *Fallowfield House, Fallowfield.*
- 1859, Jan. 25. Maclure, John William, M.P., F.R.G.S. *Whalley Range.*
- 1875, Jan. 26. Mann, John Dixon, Professor of Medical Jurisprudence, M.D., F.R.C.P., Lond. 16, *St. John Street.*
- 1864, Nov. 1. Mather, William, M.P. *Iron Works, Salford.*
- 1873, Mar. 18. Melvill, James Cosmo, M.A., F.L.S., *Brook House, Sedgely Park, Prestwich.*
- 1879, Dec. 30. Millar, John Bell, M.E., Lecturer in Engineering, *Owens College.*
- 1881, Oct. 18. Mond, Ludwig, Ph.D., F.R.S., &c. *Winnington Hall, Northwich.*
- 1894, Feb. 6. Mond, Robt., M.A. *Winnington Hall, Northwich.*
- 1873, Mar. 4. Nicholson, Francis, F.Z.S. 111, *Portland Street.*
- 1889, April 16. Norbury, George. *Hillside, Prestwich Park, Prestwich.*
- 1862, Dec. 30. Ogden, Samuel. 10, *Mosley Street West.*
- 1884, April 15. Okell, Samuel, F.R.A.S. *Overley, Langham Road, Bowdon.*
- 1844, April 30. Ormerod, Henry Mere, F.G.S. 5, *Clarence Street.*
- 1892, Feb. 23. Pankhurst, R. M., LL.D. (Lond.), Barrister-at-Law. *St. James' Square, Manchester.*
- 1861, April 30. Parlane, James. *Rusholme.*
- 1876, Nov. 28. Parry, Thomas, F.S.S. *Grafton House, Ashton-under-Lyne.*
- 1892, Nov. 15. Perkin, W. H., jun., Ph.D., F.R.S., Professor of Organic Chemistry. *Owens College.*
- 1885, Nov. 17. Phillips, Henry Harcourt, F.C.S. 183, *Moss Lane East, Manchester.*
- 1854, Jan. 24. Pochin, Henry Davis, F.C.S. *Bodnant Hall, Conway.*
- 1854, Feb. 7. Ramsbottom, John, M. Inst. C.E. *Fernhill, Alderley Edge.*
- 1859, April 16. Ransome, Arthur, M.A., M.D., Cantab., F.R.S., M.R.C.S. 1, *St. Peter's Square.*
- 1888, Feb. 21. Rée, Alfred, Ph.D., F.C.S. 1, *Brighton Grove, Rusholme.*
- 1869, Nov. 16. Reynolds, Osborne, LL.D., M.A., F.R.S., M. Inst. C.E., Professor of Engineering, Owens College. *Ladybarn Road, Fallowfield.*
- 1884, April 3. Rhodes, James, F.R.C.S. *Glossop.*
- 1880, Mar. 23. Roberts, D. Lloyd, M.D., F.R.S.Ed., F.R.C.P. (London). *Ravenswood, Broughton Park.*

*Date of Election.*

- 1864, Dec. 27. Robinson, John, M. Inst. C.E. *Westwood Hall, Leek.*  
 1858, Jan. 26. Roscoe, Sir Henry Enfield, B.A., LL.D., D.C.L., F.R.S.,  
 F.C.S., M.P. 10, *Bramham Gardens, Wetherby Road,*  
*London, S.W.*
- 1893, Mar. 21. Schill, C. H. 117, *Portland Street, Manchester.*  
 1842, Jan. 25. Schunck, Edward, Ph.D., F.R.S., F.C.S. *Kersal.*  
 1873, Nov. 18. Schuster, Arthur, Ph.D., F.R.S., F.R.A.S., Professor of  
 Physics. *Owens College.*  
 1890, Jan. 21. Sidebotham, James Nasmyth. *Parkfield, Groby Place,*  
*Altrincham.*  
 1890, Nov. 4. Sidebotham, Edward. *Earlsdene, Bowdon.*  
 1886, April 6. Simon, Henry, M.I.C.E. *Darwin House, Didsbury.*  
 1894, Jan. 9. Stephens, Marshall, F.S.S. *Highfield House, Urmston.*  
 1892, Nov. 29. Swindells, Rupert, M.I.C.E. *Wilton Villa, The Firs,*  
*Bowdon.*
- 1893, Nov. 14. Taylor, R. L., Science Master. *Central School, City.*  
 1884, Mar. 18. Thompson, Alderman Joseph. *Riversdale, Wilmslow.*  
 1873, April 15. Thomson, William, F.R.S.E., F.C.S., F.I.C. *Royal*  
*Institution, Manchester.*  
 1889, April 30. Thornber, Harry, *Rookfield Avenue, Sale.*  
 1860, April 17. Trapp, Samuel Clement. 88, *Mosley Street.*
- 1879, Dec. 30. Ward, Thomas. *Brookfield House, Northwich.*  
 1873, Nov. 18. Waters, Arthur William, F.G.S. *Villa Vecchia, Davos*  
*Dörfti, Switzerland.*  
 1859, Jan. 25. Wilde, Henry, F.R.S. *The Hurst, Alderley Edge.*  
 1859, April 19. Wilkinson, Thomas Read. *Manchester and Salford Bank,*  
*Mosley Street.*  
 1889, Nov. 12. Willans, J. W. *Woodlands Park, Altrincham.*  
 1888, April 17. Williams, Sir E. Leader, M. Inst. C.E.. *Spring Gardens,*  
*Manchester.*  
 1889, April 16. Wilson, Thomas B. 37, *Arcade Chambers, St. Mary's Gate.*  
 1860, April 17. Woolley, George Stephen. *Victoria Bridge, Salford.*  
 1863, Nov. 17. Worthington, Samuel Barton, M. Inst. C.E. *Mill Bank,*  
*Bowdon, and 33, Princess Street, City.*  
 1865, Feb. 21. Worthington, Thomas, F.R.I.B.A. 46, *Brown Street.*  
 1892, Nov. 15. Weiss, F.E., Professor of Botany, Owens College. 4,  
*Clifton Avenue, Fallowfield.*

N.B.—Of the above list the following have compounded for their subscriptions, and are therefore life members :

Brogden, Henry.  
 Johnson, William H., B.Sc.  
 Bradley, N.  
 Lowe, Charles, F.C.S.  
 Bailey, Charles, F.L.S.



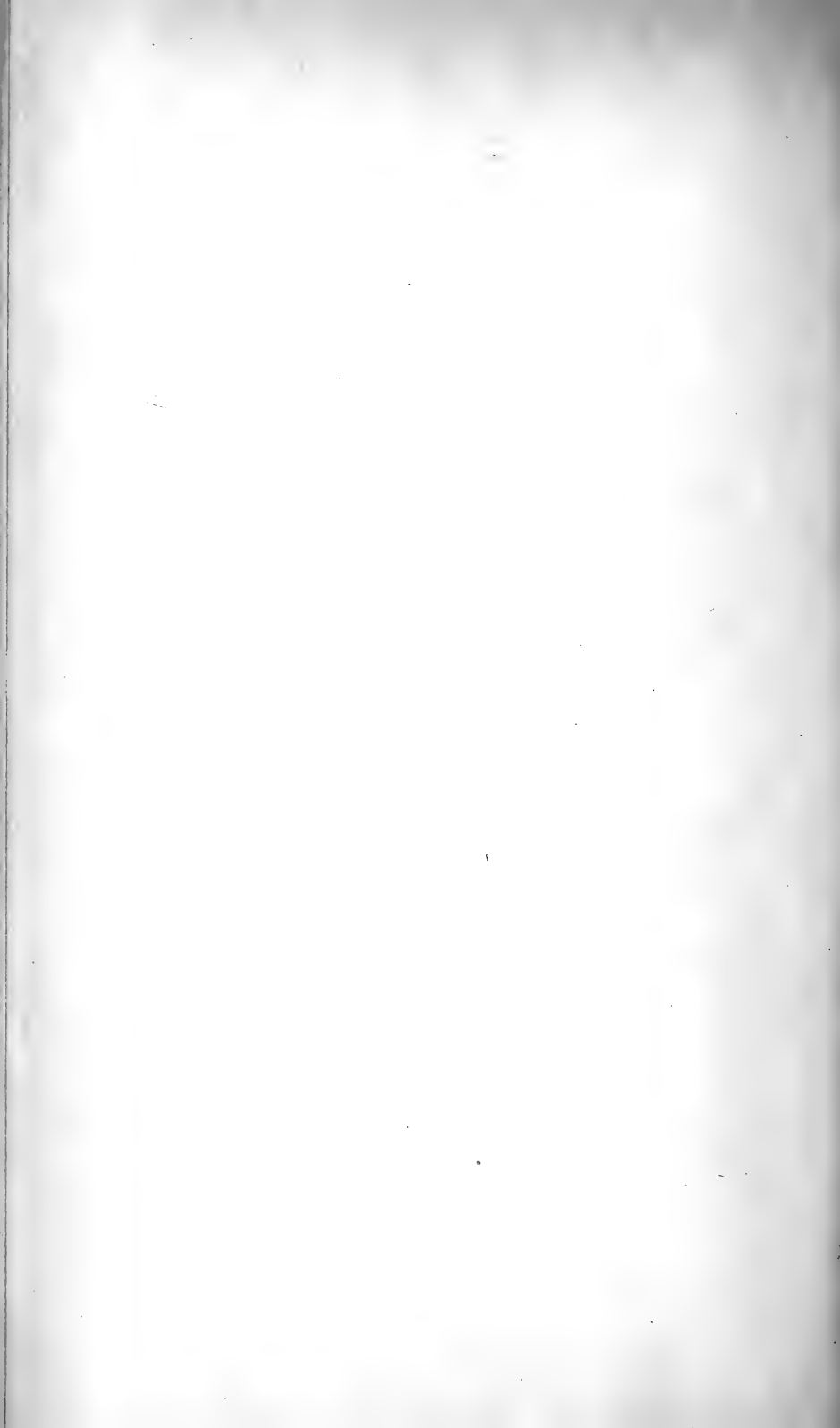



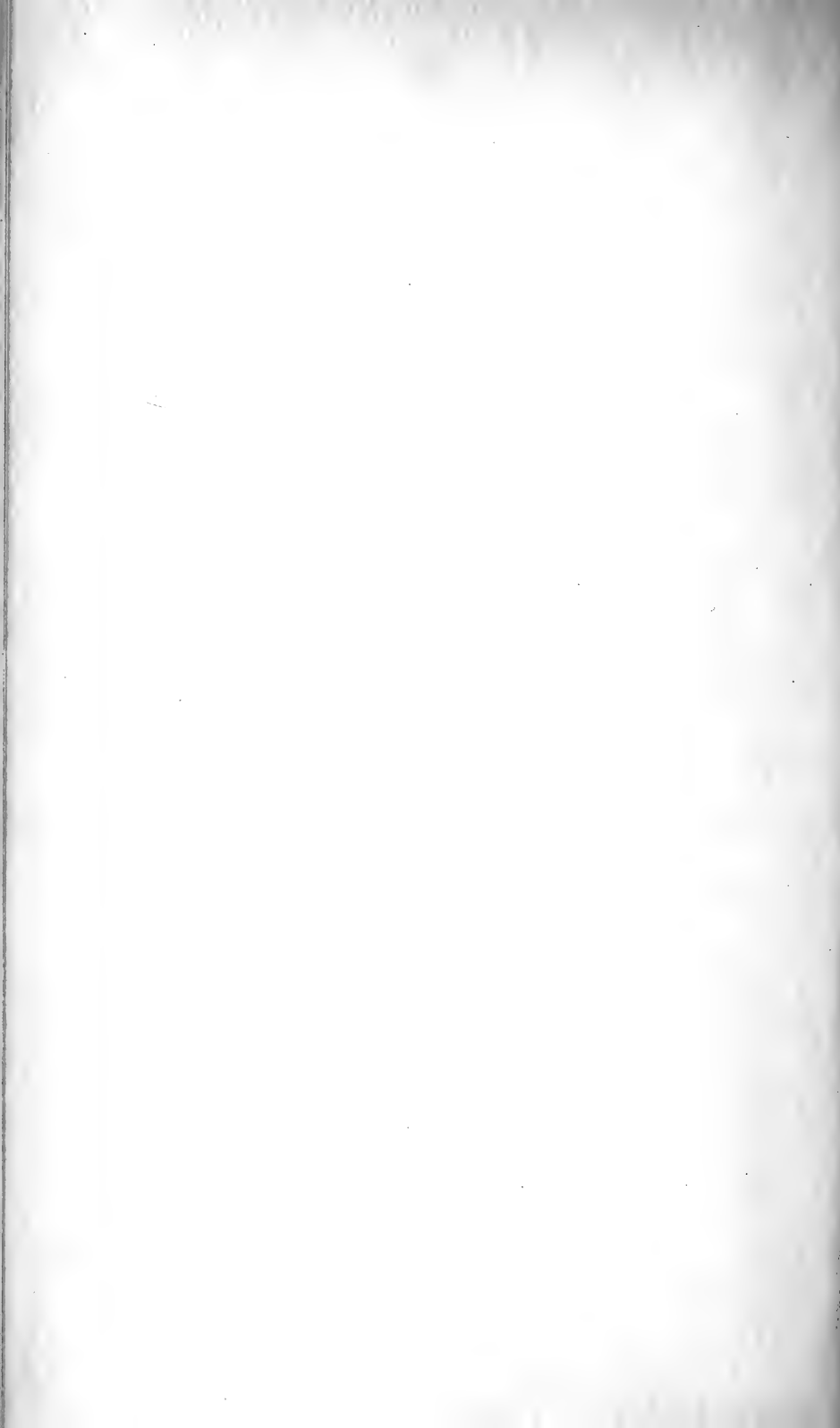







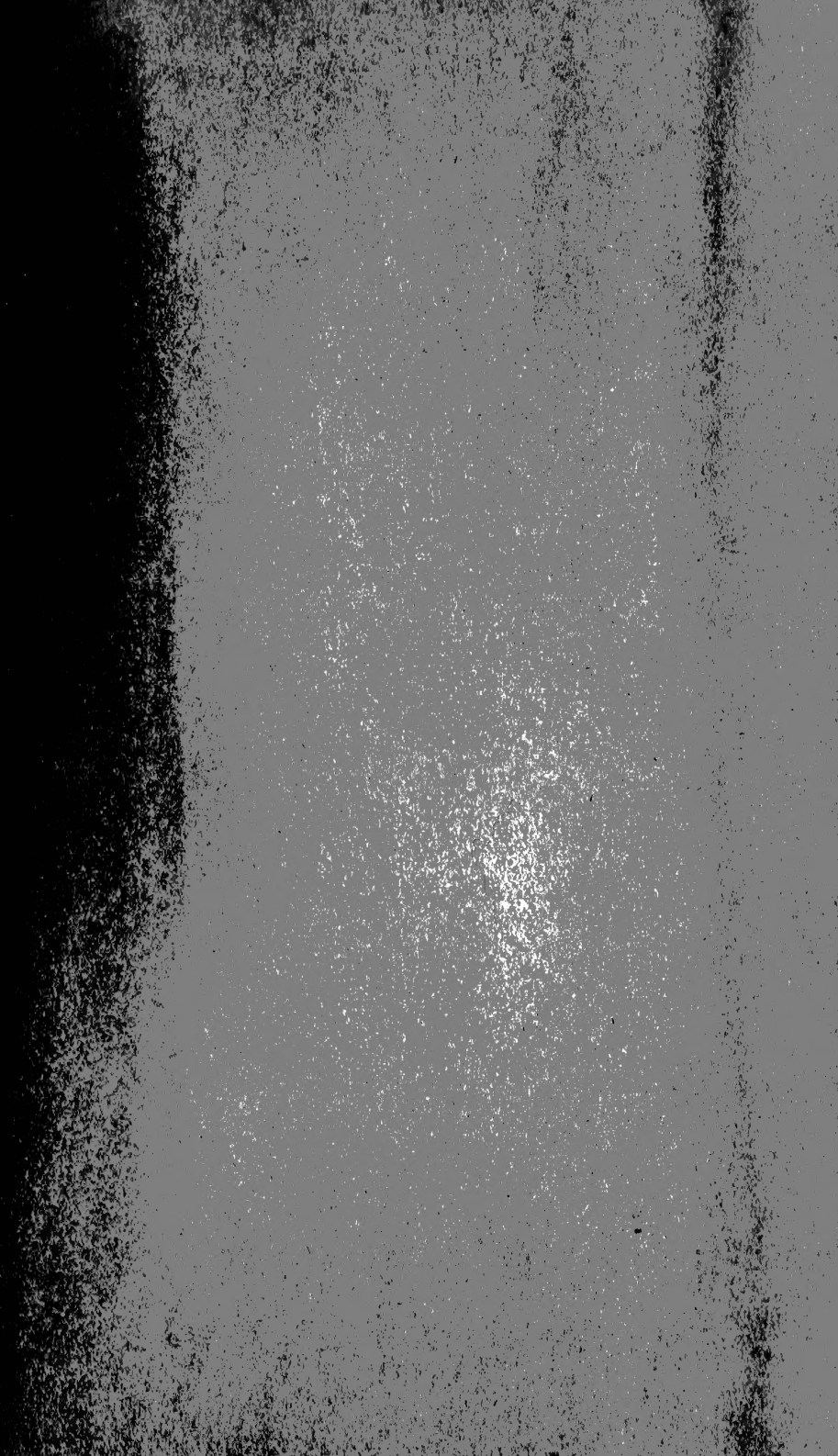

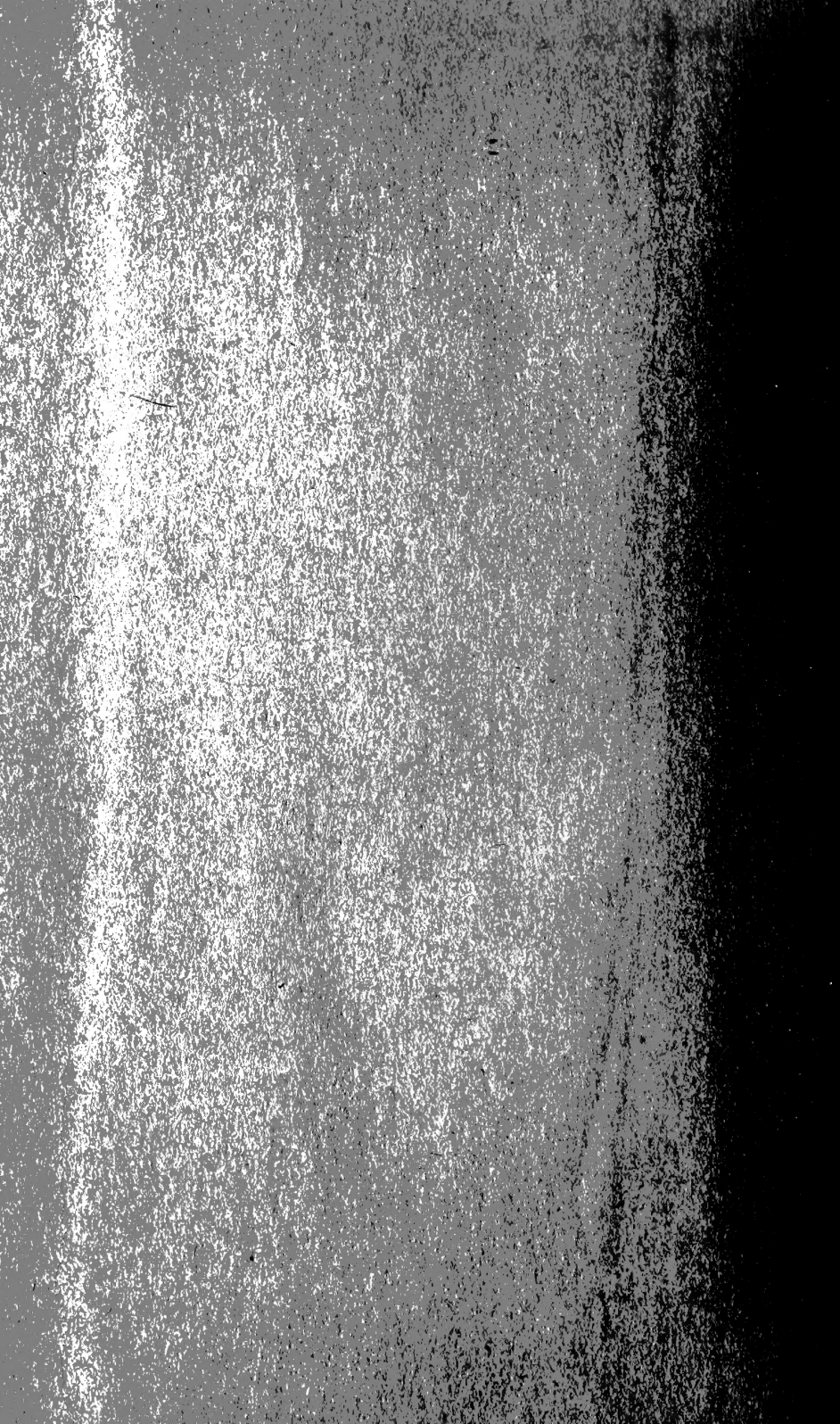



SMITHSONIAN INSTITUTION LIBRARIES



3 9088 01303 5803